



EZR[®] Zero Turn Mower

Owner/Operator Manual

Models

- 915013 - 1742 EZR
- 915020 - 1540 EZR
- 915021 - 1740 EZR
- 915022 - 1742 EZR
- 915023 - 2048 EZR
- 915308 - 1742 EZR

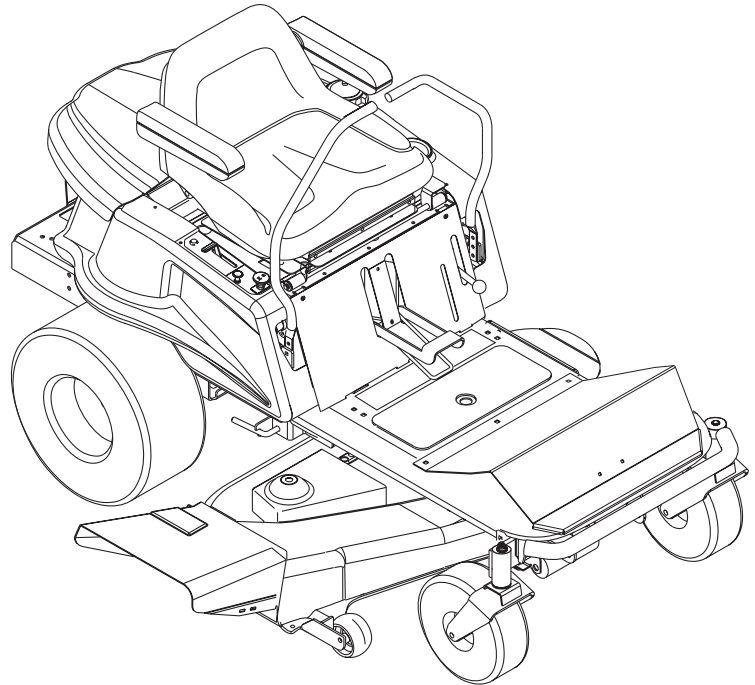

- GB ENGLISH
- F FRANÇAIS
- E ESPAÑOL



Ariens Company
655 West Ryan Street
P.O. Box 157
Brillion, Wisconsin 54110-0157
USA
Telephone (920) 756-2141
Facsimile (920) 756-2407

MODEL DECLARATION OF CONFORMITY ISSUED BY THE MANUFACTURER
CERTIFICAT DE CONFORMITÉ DU MODÈLE DÉLIVRÉ PAR LE FABRICANT
VOM HERSTELLER AUSGESTELLTE
MODELL-ÜBEREINSTIMMUNGSERKLÄRUNG
MODEL CERTIFICAAT VAN OVEREENSTEMMING AFGEGEVEN DOOR DE FABRIKANT
DICHIARAZIONE DI CONFORMITÀ DEL PRODOTTO REALIZZATA DAL PRODUTTORE
MODELO DE DECLARACIÓN DE CONFORMIDAD EMITIDA POR EL FABRICANTE

MODEL KONFORMITETSERKLÆRING UDSTEDT AF FABRIKANTEN
MODELLENS SAMSVARERKLÆRING UTFERDIGET AV PRODUSENTEN
FÖRSÄKRAN OM MODELLÖVERENSSTÄMMELSE, UTFÄRDAT AV TILLVERKAREN

We the undersigned, - Je soussigné, - Mit meiner Unterschrift - Wij de ondergetekenden, - Il sottoscritto, - El abajo firmante - Undertegnede, - Undertecknaren av detta dokument, - Me, allekirjoittaneet,

ARIENS COMPANY, declare that the Lawn Mower- certifie que la tondeuse à gazon - erklært, dass der Rasenmäher - verklaart dat de maaitrekker - dichiara che il tosaerba - certifica que el cortacésped - erklærer, at græsslåmaskinen - erklærer at plenklipperen - intygar att gräsklipparen:

Category: **RIDING ROTARY LAWNMOWER**

Make and Trade Name: **ARIENS**

Model: 915308

Serial #Range: 00101 and up

Cutting Width (cm): 106.7

conform to the specifications of directive 2000/14/EC, 98/37/EC, 89/336/EEC and their current amendments.
est conforme aux spécifications des directives 2000/14/CE, 98/37/CE et 89/336/CEE et à leurs modifications actuelles.

den Spezifikationen der Richtlinie 2000/14/EC, 98/37/EC, 89/336/EEC und deren aktuellen Zusätzen entspricht.
voldoet aan de specificaties van richtlijn 2000/14/EG, 98/37/EG, 89/336/EEG en recente aanvullingen hierop.
è conforme alle specifiche contenute nelle direttive 2000/14/EC, 98/37/EC, 89/336/EEC e nei loro relativi emendamenti.

cumple las especificaciones de la normativa 2000/14/EC, 98/37/EC, 89/336/EEC y sus enmiendas en curso.
opfylder spesifikationerne i Direktiv 2000/14/EF, 98/37/EF, 89/336/EØF og gældende ændringer.
er i overensstemmelse med spesifikasjonene i direktiv 2000/14/EF, 98/37/EF, 89/336/EØF og de gjeldende endringer.

överensstämmer med specifikationerna i direktiven 2000/14/EC, 98/37/EC, 89/336/EEC och deras nuvarande tillägg.

<p>Representative Measured Sound Power Level - Niveau de puissance acoustique représentatif Repräsentativer gemessener Geräuschpegel Typisch gemeten geluidssterkteniveau Livello di potenza sonora rappresentativo rilevato Nivel de potencia acústica representativo medido Repræsentativt målt lydstyrkeniveau Representativt målt lydeffektnivå Representativt uppmätt ljudnivå</p>	<p>99 dB_A</p>	<p>Guaranteed Sound Power Level - Niveau garanti de puissance acoustique Garantierter Geräuschpegel Gegarandeerd geluidssterkteniveau Livello di potenza sonora garantito Nivel de potencia acústica garantizado Garanteret lydstyrkeniveau Garantert lydeffektnivå Garanterad ljudnivå</p>	<p>100 dB_A</p>
---	--------------------------	---	---------------------------

Stated Sound Power Levels are established following Annex VIII "Full Quality Assurance" of directive 2000/14/EC.
Les déclarations de niveau de puissance acoustique sont établies conformément à l'Article VIII « Assurance qualité totale » de la directive 2000/14/CE.

Die angegebenen Geräuschpegel wurden gemäß Anhang VIII „Totales Qualitäts-Management“ der EU-Richtlinie 2000/14/EC.

Gespecificeerde geluidssterkteniveaus zijn vastgesteld aan de hand van Annex VIII "Full Quality Assurance" (Volledige kwaliteitsborging) van richtlijn 2000/14/EG.

I livelli di potenza sonora dichiarati sono rilevati in base all'Appendice VIII del "Controllo qualità totale" della direttiva CE/2000/14.

Los niveles de potencia acústica se establecen siguiendo el Anexo VIII "Garantía de calidad total" de la directiva 2000/14/EC.

De anførte lydstyrkeniveauer er fastlagte efter tillæg VIII "Fuld kvalitets sikring" i direktiv 2000/14/EF.

Lydeffektnivåene er fastsatt etter tillegg VIII "Full kvalitetssikring" i direktivet 2000/14/EF.

Fastställda ljudnivåer har etablerats enligt bilaga VIII "Full kvalitetssäkring" i direktiv 2000/14/EC.

Notified Body –	SNCH/TUV Rheinland
Entité notifiée – Benachrichtigte	11, Route de Luxembourg
Körperschaft – Certificeringsinstantie	L-5230 Sandweiler
–Organismo notificato – Cuerpo	
notificado – Bekendtgjort til – Kunngjøring	
til – Underrättad myndighet –	

Keeper of Technical File-	Barry Adamski
Dépositaire du fichier technique - Verwalter der	Product Team Leader
technischen Dokumente - Houder technische	Chef d'équipe de produit - Produktteam-Leiter - Teamleiter
gegevens - Depositario del file tecnico -	Product - Capo team produttivo - Jefe del equipo del producto
Depositario del archivo técnico - Ansvarlig for	- Produktansvarlig - Produktansvarlig - Produktledare
teknisk data - Ansvarlig for teknisk	Ariens Company
dokumentasjon - Innehavare of teknisk fil -	

Signature/Unterschrift/
Handtekening/Firma/U
nderskrift/Underskrift
Handlekening/Unders
krift/Allekirjoitus



Gerald Johnson
Manager of Product Conformance
Position/Qualité/Functie/Qualifica/Puesto/Stilling/Titel/Arvo
Ariens Company

3/6/02

Date/Datum/Dat
a/Fecha/Dato/Pä
iväys

 **WARNING** 

The engine exhaust from this product contains chemicals known to the State of California to cause cancer, birth defects or other reproductive harm.

CONTROLS AND FEATURES

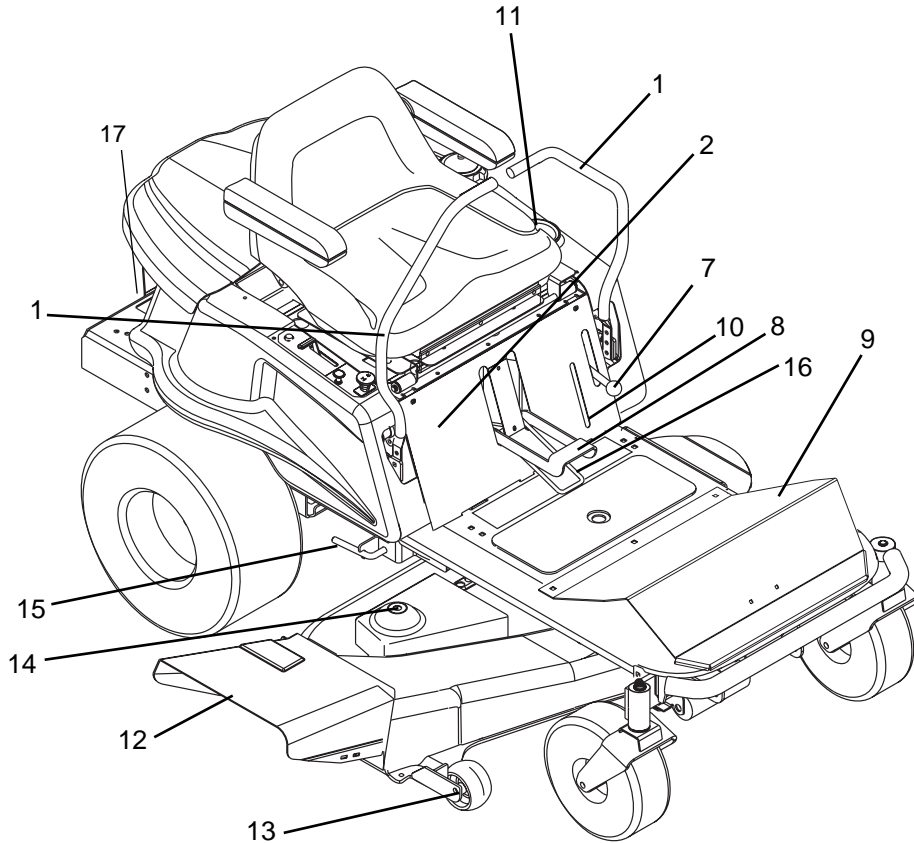

OE0930

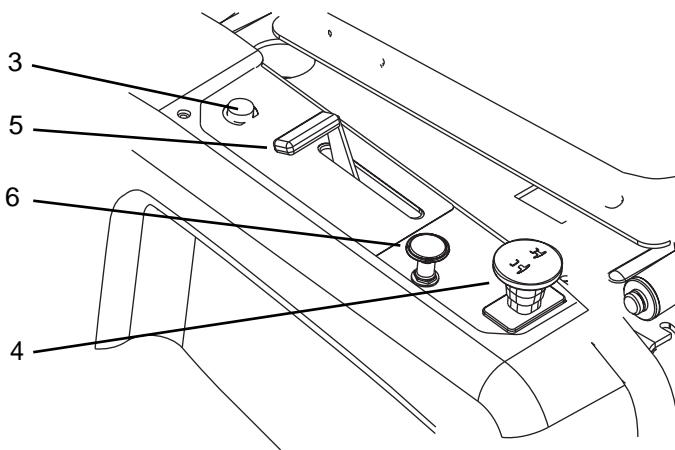

OE0860

10. Fuel Level Indicator Window
11. Fuel Tank Cap
12. Chute Deflector
13. Anti-Scalp Rollers
14. Belt Cover
15. Attachment Lift Lever Lock
16. Release Lever
17. Transmission Dump Valves

FRANÇAIS

1. Leviers de commande de direction
2. Compartiment batterie
3. Clé de contact
4. Commande de la PdF
5. Manette des gaz (915022, 023)
Manette des gaz/starter (915013, 020, 022, 308)
6. Starter (915022, 023)
7. Frein de stationnement
8. Levier de relevage de l'outil
9. Repose-pied
10. Regard de l'indicateur de niveau de carburant
11. Bouchon du réservoir de carburant
12. Goulotte d'évacuation
13. Rouleaux anti-scalp
14. Couvercle de la courroie
15. Dispositif de verrouillage du levier de relevage de l'outil
16. Levier de frein de stationnement
17. Soupapes de décharge de la transmission

ESPAÑOL

1. Palancas de control de dirección
2. Compartimento de la batería
3. Interruptor de encendido
4. Interruptor de la toma de fuerza (TDF)
5. Control del acelerador (915022, 023)
Control del acelerador/estrangulador (915013, 020, 022, 308)
6. Control del estrangulador (915022, 023)
7. Palanca del freno de estacionamiento
8. Palanca de elevación del accesorio
9. Reposapiés
10. Ventana del indicador del nivel de combustible
11. Tapón del depósito del combustible
12. Tolla de descarga
13. Rodillos antidesbrozo
14. Cubierta de la correa
15. Traba de la palanca de elevación del accesorio
16. Palanca de liberación
17. Vástago de la válvula de descarga

ENGLISH

1. Steering Control Levers
2. Battery Compartment
3. Ignition Switch
4. Power Take Off (PTO) Switch
5. Throttle Control (915022, 023)
Throttle/Choke Control (915013, 020, 022, 308)
6. Choke Control (915022, 023)
7. Parking Brake Lever
8. Attachment Lift Lever
9. Foot Rest

TABLE OF CONTENTS

Controls and Features	4	Attachments and Accessories	30
Safety	6	Service Parts	30
Assembly	10	Troubleshooting	31
Operation	11	Specifications	32
Maintenance	16	Warranty	33
Service and Adjustments	21		
Storage	29		

INTRODUCTION

THE MANUAL

Before operation of unit, carefully and completely read your manuals. The contents will provide you with an understanding of safety instructions and controls during normal operation and maintenance.

All reference to left, right, front, or rear are given from operator standing in operation position and facing the direction of forward travel.

MODEL AND SERIAL NUMBERS

Transfer model & serial number label from product registration here.

When ordering replacement parts or making service inquiries, know the Model and Serial numbers of your unit and engine.

Numbers are located on the product registration form in the unit literature package. They are printed on a serial number label, located on the frame of your unit.

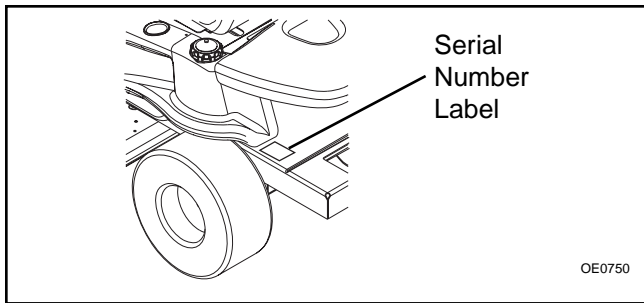

- Record Unit Model and Serial numbers here.

- Record Engine Model and Serial numbers here.

PRODUCT REGISTRATION

A warranty registration card must be filled out, signed, and returned at time of purchase. This card activates the warranty. Claims meeting requirements during limited warranty period will be honored.

UNAUTHORIZED REPLACEMENT PARTS

Use only Ariens replacement parts. The replacement of any part on this vehicle with anything other than an Ariens authorized replacement part may adversely affect the performance, durability, or safety of this unit and may void the warranty. Ariens disclaims liability for any claims or damages, whether warranty, property damage, personal injury or death arising out of the use of unauthorized replacement parts.

For a brief list of replacement parts see *Service Parts* in this manual. To obtain a complete parts manual, find your model and serial number. Then go to www.ariens.com or call 1-800-678-5443.

DISCLAIMER

Ariens reserves the right to discontinue, make changes to, and add improvements upon its products at any time without public notice or obligation. The descriptions and specifications contained in this manual were in effect at printing. Equipment described within this manual may be optional. Some illustrations may not be applicable to your unit.

DELIVERY

Customer Note: If you have purchased this product without complete assembly and instruction by your retailer, it is your responsibility to:

1. Read and understand all assembly instructions in this manual. If you do not understand or have difficulty following the instructions, contact your nearest Ariens Dealer for assistance. Make sure all assembly has been properly completed.

NOTE: To locate your nearest Ariens Dealer, call 1-800-678-5443 or go to www.ariens.com on the internet.

 **WARNING:** Improper assembly or adjustments can cause serious injury.

- 2. Understand all Safety Precautions provided in the manuals.

- 3. Review control functions and operation of the unit. Do not operate the unit unless all controls function as described in this manual.
- 4. Review recommended lubrication, maintenance and adjustments.
- 5. Review Limited Warranty Policy. Fill out Original Purchaser Registration Card and return the card to Ariens Company.

SAFETY

SAFETY ALERTS



Look for these symbols to point out important safety precautions. They mean:

Attention!



Personal Safety Is Involved!

Become Alert!

Obey The Message!

The safety alert symbols above and signal words below are used on decals and in this manual.

Read and understand all safety messages.

 **DANGER: IMMINENTLY HAZARDOUS SITUATION!** If not avoided, **WILL RESULT** in death or serious injury.

 **WARNING: POTENTIALLY HAZARDOUS SITUATION!** If not avoided, **COULD RESULT** in death or serious injury.

 **CAUTION: POTENTIALLY HAZARDOUS SITUATION!** If not avoided, **MAY RESULT** in minor or moderate injury. It may also be used to alert against unsafe practices.

NOTATIONS

NOTE: General reference information for proper operation and maintenance practices.

IMPORTANT: Specific procedures or information required to prevent damage to unit or attachment.

PRACTICES AND LAWS

Practice usual and customary safe working precautions, for the benefit of yourself and others. Understand and follow all safety messages. Be alert to unsafe conditions and the possibility of minor, moderate, or serious injury or death. Learn applicable rules and laws in your area.

REQUIRED OPERATOR TRAINING

Original purchaser of this unit was instructed by the seller on safe and proper operation. If unit is to be used by someone other than original purchaser; loaned, rented or sold, ALWAYS provide this manual and any needed safety training before operation.

SAFETY DECALS AND LOCATIONS

ALWAYS replace missing or damaged Safety Decals. Refer to figure below for Safety Decal locations.

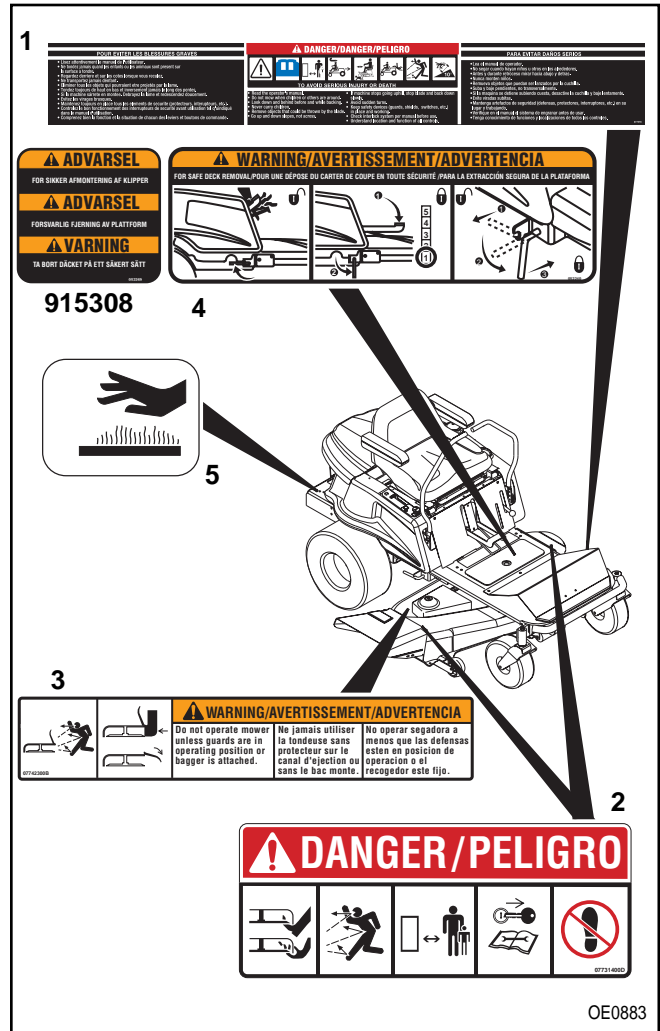

1. DANGER!

TO AVOID SERIOUS INJURY OR DEATH



OL1801

Read operator's manual.



OL4140

Keep children and others away from unit while operating.



OL4100

Look down and behind before and while backing.



OL4110

Never carry children, even if mower is disengaged.



OL4120

Never direct discharge toward other people. Thrown objects can cause injury.



OL0910

Go up and down slopes, not across. Do not operate on slopes that exceed 10°.



OL4130

- If machine stops going uphill, stop blade and back down slowly.
- Avoid sudden turns.
- Keep safety devices (guards, shields, switches, etc.) in place and working.
- Check interlock system per manual before use.
- Understand location and function of all controls.
- Never allow operation by untrained persons.

2. DANGER ROTATING PARTS



OL3030

Always keep feet and hands away from rotating parts.



OL0910

Never direct discharge toward other people. Thrown objects can cause injury.



OL4140

Keep people away from unit while operating.



OL4010

Shut off engine, remove key, read manual before you adjust or repair unit.



OL4420

NO STEP! Always keep feet away from rotating parts.

3. WARNING - KEEP GUARDS IN PLACE



OL4430

Always stand clear of the discharge area when operating this unit.



OL3320

Do not operate mower unless guards are in operating position or bagger is attached.

4. WARNING - FOR SAFE DECK REMOVAL

Avoid injury from stored energy in lift assist spring.

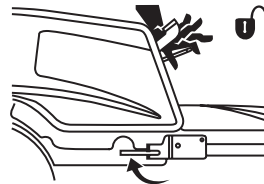

OE0770

Lift lever can spring up quickly if released while mower deck is removed. Do not unlock attachment lift lever when mower deck is removed.

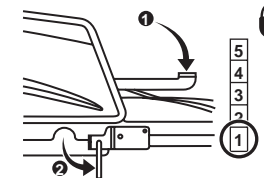

OE0780

Before removing the mower deck, ❶ lower the attachment lift lever to position 1, then ❷ latch and lock the lock pin.

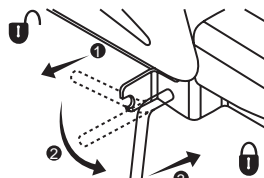

OE0790

To properly latch and lock the lock pin.

- ❶ Pull the pin out of the latched unlocked position.
- ❷ Rotate the lock pin downward 90°.
- ❸ Push lock pin in to locked position.

5. AVOID HOT SURFACES



OS0732

HOT SURFACES! DO NOT touch parts which are hot from operation. Always allow parts to cool.

SAFETY RULES

Operation

Read, understand, and follow all instructions in the manual and on the machine before starting:

- How to operate all controls

- The functions of all controls
- How to stop in an emergency
- Braking and steering characteristics
- Turning radius and clearances

ALWAYS keep protective structures, guards, and panels in good repair, in place and securely fastened. Maintain or replace safety and instruction labels, as necessary.

Complete a walk-around inspection of the unit and work area.

ALWAYS disengage PTO, stop unit and engine, remove key, engage parking brake and allow moving parts to stop before leaving operator's position.

ALWAYS remove key to prevent unauthorized use.

Check for weak spots on dock, ramps or floors. Avoid uneven work areas and rough terrain.

Dust, smoke, fog, etc. can reduce vision and cause an accident. Mow only in daylight or good artificial light.

Watch for traffic when operating near or crossing roadways.

Only allow responsible adults who are trained and familiar with the instructions to operate the machine.

Training includes actual operation.

Clear the area of objects such as tree branches, rocks, toys, wire, etc., which could be picked up and thrown by the blades. Tall grass can hide obstacles.

Be sure the area is clear of people before mowing. Stop machine if anyone enters the area.

Use extra care when approaching blind corners, shrubs, trees, or other objects that may obscure vision.

Watch for holes, ruts, or bumps. Uneven terrain could overturn the machine.

Do not mow in reverse unless absolutely necessary. Always look down and behind before and while backing.

Be aware of the mower discharge direction and do not point it at anyone. Always stand clear of discharge area.

DO NOT operate at too fast a rate.

DO NOT change engine governor settings or over-speed engine. Slow down before turning.

Disengage PTO when attachment is not in use.

ALWAYS turn off power to attachment when transporting, crossing driveways, etc.

Stop engine before removing grass catcher or unclogging chute.

Do not operate mower unless bagger is attached or guards are in operating position.

If you cannot back up a slope or you feel uneasy on it, do not mow it.

Mow up and down slopes, not across them.

Use slow speed on any slope. Choose a low gear so that you will not have to stop or shift while on the slope.

Follow the manufacturer's recommendations for wheel weights or counterweights to improve stability.

Use a slow speed. Choose a low gear so that you will not have to stop or shift while on the slope. Tires may lose traction on slopes even though the brakes are functioning properly.

Use extra care with grass catchers or other attachments. These can change the stability of the machine. Use only approved hitch points.

Keep all movements on the slope *slow* and *gradual*. Do not make sudden changes in speed or direction.

Avoid starting or stopping on the slope. If tires lose traction, disengage the blades and proceed slowly *straight* down the slope.

Do not shift to neutral and coast downhill.

Do not mow near dropoffs, ditches, or embankments. The mower could suddenly turn over if a wheel is over the edge of a cliff or ditch, or if an edge caves in.

Do not mow on wet grass. Reduced traction could cause sliding.

Do not try to stabilize the machine by putting your foot on the ground.

Do not use grass catcher on steep slopes.

Do not operate on slopes over 10° maximum.

Do not park on slopes unless necessary. When parking on slope always chock or block wheels. Always set parking brake.

Know the weight of loads. Limit loads to those you can safely control and the unit can safely handle.

Use only attachments or accessories designed for your unit.

Check attachment components frequently. If worn or damaged, replace with manufacturer's recommended parts.

Personal

Data indicates that operators, age 60 and above, are involved in a larger percentage of riding mower related injuries. These operators should evaluate their ability to operate the riding mower safely enough to protect themselves and others from serious injury.

Never carry passengers.

Always wear safety glasses or eye shields while operating your tractor or performing any adjustments or repairs. We recommend a wide vision safety mask over eye glasses, or standard safety glasses.

Protect eyes, face and head from objects that may be thrown from unit. Wear appropriate hearing protection.

NEVER wear open sandals or canvas shoes during operation. Wear adequate safety gear, protective gloves and footwear.

Avoid slippery surfaces. Always be sure of your footing. Keep all nonskid surfaces clean. Replace safety treads if worn, damaged, or missing.

Always keep hands and feet away from rotating parts. Do not step on mower deck when mounting, operating or dismounting tractor.

NEVER operate the machine after or during the use of medication, alcohol or drugs. Safe operation requires your complete and unimpaired attention at all times.

NEVER allow anyone to operate this unit when their alertness or coordination is impaired.

Do not touch parts which are hot from operation. ALWAYS allow parts to cool.

Always keep hands away from all pinch points.

NEVER place your hands or any part of your body or clothing inside or near any moving part while unit is running.

DO NOT wear loose clothing or jewelry. Tie back hair that may get caught in rotating parts.

Always stand clear of discharge area.

Keep people away from unit while operating.

Shut off engine, remove key, read manual before you unplug, adjust or repair unit.

DO NOT run engine in an enclosed area. Always provide good ventilation. Fumes from engine exhaust can cause injury or death.

Keep children out of the mowing area and under the watchful care of another responsible adult.

Be alert and turn off machine if children enter the area. Before and when backing up, look behind and down for small children.

Never carry children, even if mower is disengaged. They may fall off and be seriously injured or interfere with safe machine operation.

Never allow children to operate or play on or near the unit.

Always keep batteries out of reach of children.

HYDRAYLIC FLUID WILL CAUSE SEVERE BURNS. Fluid in the hydraulic system can penetrate the skin and cause death or serious injury.

Transport

NEVER push or pull (tow) unit with another vehicle. Transmission damage will occur.

Use extra care when loading or unloading the machine into a trailer or truck.

Secure unit chassis to transport vehicle. Never secure by linkages which could become damaged.

DO NOT transport machine while engine is running.

DO NOT transport with attachment in the lowered (operating) position.

Towing

Tow only with a machine that has a hitch designed for towing. Do not attach towed equipment except at the hitch point.

Follow the manufacturer's recommendations for weight limits for towed equipment and towing on slopes.

Never allow children or others in or on towed equipment.

On slopes, the weight of the towed equipment may cause loss of traction and loss of control.

Travel slowly and allow extra distance to stop.

Service

Before making any inspections, repairs, adjustments, etc. disengage PTO, stop unit and engine, remove key, and allow moving parts to stop.

ALWAYS block wheels and know all jack stands are strong and secure and will hold weight of unit during maintenance.

Use extra care in handling gasoline and other fuels. They are flammable and vapors are explosive.

- Use only an approved container.
- Never remove gas cap or add fuel with the engine running. Allow engine to cool before refueling. Do not smoke.
- Never refuel the machine indoors.
- Never store the machine or fuel container inside a building where there is an open flame, such as a water heater.

Never fill containers inside a vehicle or on a truck or trailer bed with a plastic liner. Always place containers on the ground away from your vehicle before filling.

When practical, remove gas-powered equipment from the truck or trailer and refuel it on the ground. If this is not possible, then refuel such equipment on a trailer with a portable container, rather than from a gasoline dispenser nozzle.

Keep the nozzle in contact with the rim of the fuel tank or container opening at all times until fueling is complete. Do not use a nozzle lock-open device.

If fuel is spilled on clothing, change clothing immediately.

Keep nuts and bolts tight, especially blade attachment bolts, and keep equipment in good condition.

Never modify, alter or permit anyone to modify or alter the unit or its components.

Never tamper with safety devices. Check their proper operation regularly. (See Operator Presence System in *Operation*)

Keep machine free of grass, leaves, or other debris.

Clean up oil or fuel spills.

Allow machine to cool before storing.

Stop and inspect equipment if you strike an object. Repair, if necessary, before restarting.

Never make adjustments or repairs with the engine running.

ALWAYS lower attachment when unit is parked or stored.

Grass catcher components are subject to wear, damage, and deterioration, which could expose moving parts or allow objects to be thrown. Frequently check components and replace with manufacturer's recommended parts, when necessary.

Mower blades are sharp and can cut you. Wrap the blade(s) or wear gloves, and use extra caution when servicing them.

IMPORTANT: On multi-blade mowers, rotation of one blade will cause all blades to rotate.

Check brake operation frequently. Adjust and service as required.

AVOID ELECTRIC SHOCK. Do not reverse battery connections.

EXPLOSIVE GASES from battery can cause death or serious injury. ALWAYS keep open flames, sparks, or smoking materials away from batteries.

POISONOUS BATTERY FLUID contains sulfuric acid and its contact with skin, eyes, or clothing can cause severe chemical burns. ALWAYS wear safety glasses and protective gear near battery.

DO NOT tip battery beyond a 30° angle in any direction.

ALWAYS maintain unit in safe operating condition. Damaged or worn muffler can cause fire or explosion.

Spark Arrester

This product is equipped with an internal combustion engine. DO NOT use on or near any unimproved, forest covered or brush covered land unless the exhaust system is equipped with a spark arrester meeting applicable local, state or federal laws. A spark arrester, if used, must be maintained in effective working order by the operator.

ASSEMBLY

To ensure safe and proper operation, all parts and hardware must be tightened securely. Use the correct tools to ensure proper tightness.

TO REMOVE TRACTOR FROM SKID

1. Remove all accessible loose parts from shipping carton.
2. Remove top and sides of crate.
3. Remove shrink wrap and packing material.
4. Cut any banding material holding tractor to skid.
5. 40" and 42" Deck - Raise mower deck attachment lift lever to its highest position.
48" Deck - Slide mower deck out from under tractor and set aside.
6. Release parking brake by pushing lever down.
7. Open transmission dump valves by lifting the dump valve knob and pulling rearward until the expanded section of the rod comes through the hole in the trailer hitch. Push the rod back down to lock it into position.

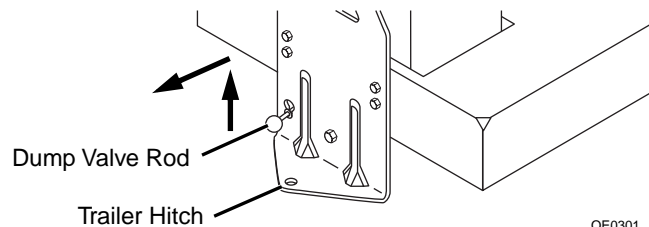

8. Carefully push the tractor from the skid to a level area.

9. 40" and 42" Deck - Remove banding holding discharge chute up against tractor.

48" Deck - Install deck per the instructions in *Service and Adjustments*.

ASSEMBLY

1. Check Levelness of Deck

Be sure mower deck is properly leveled side-to-side/front-to-rear for best cutting results. (Tires must be properly inflated for leveling. See *Specifications*.) See Deck Leveling in *Service and Adjustments*.

2. Check Battery

If the battery is put into service after the month and year indicated on the battery, it must be charged before use. With a 12 volt battery charger, charge the battery for a minimum of one hour and no more than two hours at a rate of 6 to 10 amps.

Remove battery from unit before servicing. See *Maintenance* for specific information.

3. Check Engine Oil

This tractor has been filled with oil at the factory. Verify engine oil level prior to starting engine and add oil if required.

4. Adjust Seat

Adjust seat to a comfortable position and tighten securely. See *Service and Adjustments*.

5. Check Tires

Make sure all tires are properly inflated. (For shipping purposes, the tires were overinflated at the factory. See *Specifications* for proper air pressure.)

6. Check Belts

Check mower and drive belts. Be sure they are routed properly around pulleys and inside all belt fingers.

7. Check Wiring

Make sure that all connections are secure and wires are properly clamped.

While learning how to use your tractor, pay extra attention to the following important items:

- Engine oil is at proper level.
- Fuel tank is filled with fresh, clean, regular unleaded gasoline.
- Become familiar with all controls – their location and function. Operate them before you start the engine.

OPERATION

CONTROLS AND FEATURES



CAUTION: The operation of any tractor can result in foreign objects thrown into the eyes, which can cause severe eye damage. Always wear safety glasses or eye shields while operating your tractor or performing any adjustments or repairs. We recommend a wide vision safety mask over eye glasses, or standard safety glasses.

Operator Presence System

Your tractor is equipped with an operator presence switch. When engine is running, any attempt by the operator to leave the seat, without first disengaging attachment and placing the Steering Control Levers in neutral, will shut off the engine.

The engine must shut off if the operator leaves the seat while the Travel-Speed Control Levers are in any position other than the "NEUTRAL LOCK" position, or while the PTO Switch is in the "ON" position.

Do not operate tractor unless operator presence system functions as described. Contact your Ariens Dealer for repair.

Ignition Switch

The ignition switch is operated with a removable key. To start the unit, the switch is turned clockwise from the "OFF" position to the "START" position. The key will spring back to the "RUN" position.

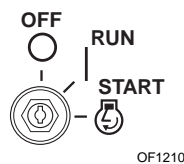

OF1210

"OFF" Position: Ignition system is shut down.

"RUN" Position: All controls are operable.

"START" Position: Starter turns over the engine.

To stop the engine, turn the key to the "OFF" position.

Choke Control (915022, 023)

When starting a cold engine:

Pull the choke control out to engage choke.

Push the choke control in after engine has warmed up for about 10 seconds.

Parking Brake

To engage the Parking Brake, lift up on lever.

To disengage the Parking Brake, push lever down.

If one or both of the wheels do not turn easily, check the brake to assure it is disengaged.

Parking Brake Interlock

Engine will shut off if control levers are taken out of neutral lock with brake engaged.

Throttle Control (915022, 023)

Always operate engine at full throttle.

Moving the lever to the "FAST" position increases the engine speed.

Moving the lever to the "SLOW" position decreases the engine speed.

- Operating engine at less than full throttle reduces the battery charging rate.
- Full throttle offers the best bagging and mower performance.

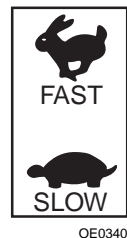

OE0340

Throttle / Choke Control (915013, 020, 021, 308)

Always operate engine at full throttle.

Place the lever in the "Choke" position to start a cold engine.

Move the lever to the "FAST" position to increase the engine speed.

Move the lever to the "SLOW" position to decrease the engine speed.

- Operating engine at less than full throttle reduces the battery charging rate.
- Full throttle offers the best bagging and mower performance.

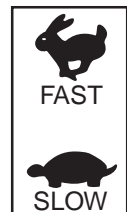

OE0340

Power Take-Off (PTO) Switch

The Power Take Off Switch is used to engage and disengage the attachment.

When the PTO Switch is pulled out, it is in the "ON" position and the attachment is engaged.



When the PTO Switch is pushed in, it is in the "OFF" position and the attachment is disengaged.



OE0261

Travel/Speed Control Levers



WARNING: This tractor is steered and stopped through the rear drive tires which are controlled by the Steering Control Levers. Any loss of tire traction will also result in loss of braking and steering control. Care must be exercised not to use unit on a slope greater than recommended. Loss of tire traction, and loss of steering and brake control could result, leading to serious injury.

Neutral Lock

To start, lock unit in neutral by pushing both Travel-Steering Control Levers outward – to each side – from centered (neutral) position.



OE0060

Neutral Lock Position

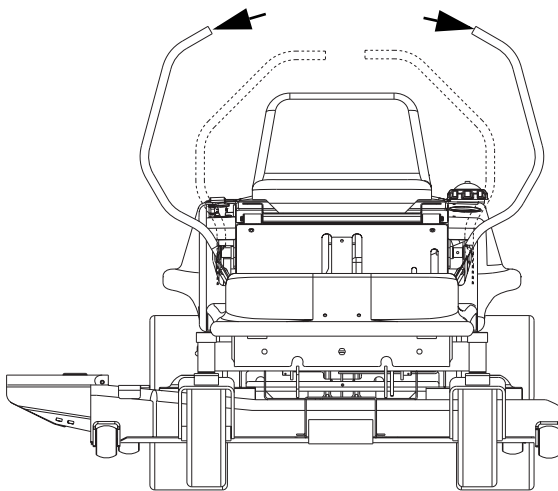

OE0162

Straight Forward

Push the Travel-Steering Control Levers SLOWLY forward the same distance from the centered (neutral) position. The further you move the levers, the faster the unit will travel forward. (Travel-Steering Control Levers have quick response timing.)



OE0200

Straight Backward

Pull the Travel-Steering Control Levers back the same distance from the centered (neutral) position. The further you move the levers, the faster the unit will travel in reverse.

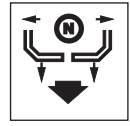

OE0210

Turns

Move one Travel-Steering Control Lever forward and the other backward. Pushing the lever forward from the centered position moves the unit forward on that side; pulling the lever back from the centered position moves the unit backward on that side.

1. Left Lever further forward than Right Lever: Turns the unit to the Right.

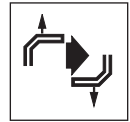

OE0230

2. Right Lever further forward than Left Lever: Turns the unit to the Left.

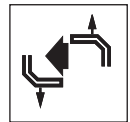

OE0220

NOTE: Aggressive turning can scuff or damage lawns. ALWAYS keep both wheels rotating when making sharp turns. DO NOT make turns with inside wheel completely stopped. To obtain minimum turning radius, slowly reverse inside wheel while moving outside wheel slowly forward.

Attachment Lift Lever

The position of the lift lever determines the cutting height.

To adjust the attachment height:

1. Squeeze release lever into handle.
2. Raise or lower attachment handle to desired height.
3. Release release lever to set position.



OT0620

Maximum cutting height is 4-3/8 inches (11.1 cm); lowest cutting height is 1-3/8 inches (3.5 cm). Intermediate positions allow cutting heights between these values.

The heights are measured from the ground to the blade tip with the engine NOT running. These heights may vary depending upon the soil conditions, height of grass and types of grass being mowed.

NOTE: On the 42" Deck, the Anti-scalp roller height must be adjusted to correspond with the attachment height so the anti-scalp rollers are not lower than the desired cutting height. See *Adjustments*.

- For best cutting performance, grass over 6 inches (15.2 cm) in height should be mowed twice. Make the first cut relatively high (4 inches [10.1 cm]); the second to desired height.



WARNING: AVOID injury from stored energy in lift assist spring. DO NOT unlock attachment lift lever with mower deck removed. ALWAYS engage Attachment Lift Lever Lock when removing mower deck.

Attachment Lift Lever Lock



WARNING: AVOID injury from stored energy in lift assist spring. DO NOT unlock attachment lift lever with mower deck removed. ALWAYS engage Attachment Lift Lever Lock when removing mower deck. See *Service and Adjustments*.

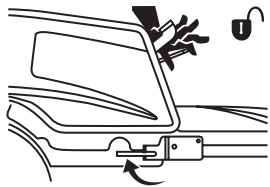

ALWAYS engage the attachment Lift Lever Lock when removing or servicing the mower deck. Lift lever can spring up quickly if released while mower deck is removed.

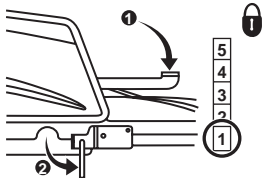

Before removing the mower deck, ❶ lower the attachment lift lever to position 1, then ❷ latch and lock the lock pin.

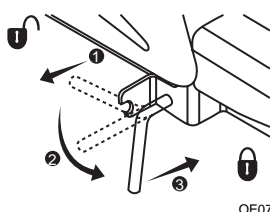

To properly latch and lock the lock pin.

- ❶ Pull the pin out of the latched unlocked position.
- ❷ Rotate the lock pin downward 90°.
- ❸ Push lock pin in to locked position.

Transmission Dump Valves

Opening the Dump Valves allows the unit to be pushed by hand. Dump Valves must be closed to drive unit.

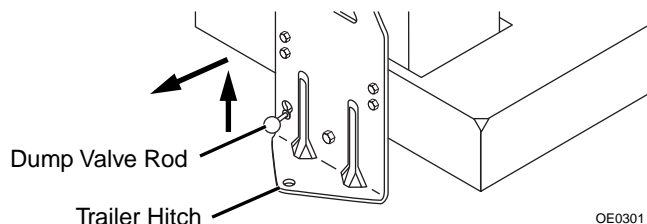

- To Open the Dump Valves: Lift up on the Dump Valve Rod Knob and pull rearward until the expanded section of the rod comes through the hole in the trailer hitch. Push the rod back down to lock it in position.
- To Close the Dump Valves: Lift up on the Dump Valve Rod and push it forward.

PRE START

1. Check Engine Oil Level

The engine in your tractor has been shipped from the factory, already filled with summer weight oil. Check engine oil with tractor on level ground.

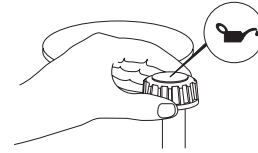

1. Remove oil fill cap/dipstick and wipe clean.
2. Reinsert the dipstick and rest the oil fill cap on the tube. Tighten the cap lightly.
3. Wait a few seconds, remove and read oil level. If necessary, add oil until "FULL" mark on dipstick is reached. Do not overfill.

For cold weather operation you should change oil for easier starting (See "Oil Viscosity Chart" in Engine Manual). To change oil, see Engine Manual.

2. Check Fuel Level

The fuel level is shown through a window in the control panel next to the parking brake.



WARNING: Fuel is highly flammable and its vapors are explosive. Handle with care. NO smoking, NO sparks, NO flames.

Refer to Engine Manual for proper fuel.

To add fuel to the fuel tank:

1. ALWAYS place unit in open or well ventilated area.
2. Stop engine and allow to cool for two minutes.
3. Clean the fuel cap and the area around the fuel cap to prevent dirt from entering the fuel tank.

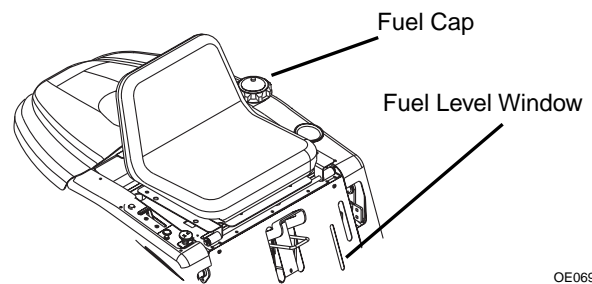

4. Remove the cap from the fuel tank.
5. Fill the fuel tank to not less than 1/2 inch (1.3 cm) of bottom of tank filler neck. Use care; do not spill fuel.
6. Replace the cap on the fuel tank and tighten.
7. ALWAYS clean up any spilled fuel before starting the engine.

STARTING THE ENGINE

NOTE: Before starting, read warm and cold starting procedures below.

1. The operator must be seated.
2. Travel-Steering Control levers must be in the "NEUTRAL-LOCK" position.
3. The PTO Switch must be in the "OFF" position.
4. For 915023, 022 - If the engine is cold, apply choke. For 915308, 021, 020, 013 - Place Throttle/Choke control in Choke position. See Engine Manual for detailed instructions.
5. Set throttle to proper starting position (915023, 022 only). See Engine Manual.
6. Turn the ignition key clockwise to the "START" position. Release the key when the engine starts.

IMPORTANT: Do not run starter continuously for more than fifteen seconds. If the engine does not start after several attempts, move throttle control to "FAST" position, wait a few minutes and try again. If engine still does not start, move the throttle control back to the choke position and retry. If engine still does not start, refer to *Troubleshooting*.

7. After the engine starts, allow it to run for about 10 seconds with choke engaged. Disengage choke slowly.
8. Set throttle to "Fast" position.
9. Wait until the engine is running smoothly before operating unit.

Warm Weather Starting (50°F, 10°C and above)

1. After engine starts, let it run with choke engaged for about 10 seconds.
2. Disengage the choke and move the throttle slowly to the fast position (915023, 022). Move the Throttle/Choke control to the fast position (915308, 021, 020, 013).
3. The attachments and ground drive should now operate. If they do not, allow engine to warm up for one minute.

Cold Weather Starting (50°F, 10°C and below)

NOTE: Refer to engine manual for cold weather oil type.

1. When the engine starts, allow engine to run with the throttle in the choke position until the engine runs roughly.
2. Move the throttle control to the fast position (915023, 022). Move the Throttle/Choke control to the fast position (915308, 021, 020, 013). This may require an engine warm-up period from several seconds to several minutes, depending on the temperature.
3. Do not engage attachment during the warm-up period.

STOPPING THE ENGINE

1. With both Travel-Steering Control Levers pulled back to centered (neutral) position, bring unit to a complete stop on level ground.
2. Put PTO in the "OFF" position.
3. Move the Throttle Lever to "SLOW" position and let unit idle for 30 seconds.
4. Turn Ignition Key to the "OFF" position.
5. Engage the Parking Brake.

TO OPERATE MOWER

Your tractor is equipped with an operator presence sensing switch. Any attempt by the operator to leave the seat with the engine running, the PTO Switch engaged, or a Steering Control Lever out of the Neutral Lock Position will shut off the engine.



CAUTION: Do not operate the mower without either the entire grass catcher on mowers so equipped, or the discharge guard in place.

Speed



WARNING: DO NOT operate at too fast a rate. Sudden forward or backward movement in Travel-Steering Control Lever(s) at fast speeds can cause accidents resulting in injury or death.

Move one or both Travel-Steering Control Lever(s) forward or backward SLOWLY until you learn how to operate the unit properly. The further you move the levers, the faster the unit will travel.

NOTE: This unit is designed to be highly maneuverable and responds quickly to movement of the Travel-Steering Control Levers. Practice operation of the controls in a flat open area until you are comfortable with their operation. ALWAYS start and backup slowly, and make turns with caution.

To mow with the unit:

1. With mower engine OFF, adjust deck to desired height of cut.
For the 42" deck, be sure to adjust the anti-scalp rollers to the correct height. See *Adjustments*.
2. Start the mower engine.
3. Move Throttle Lever to about half speed.
4. Pull PTO Switch to the "ON" position to engage the mower.
5. Move the Throttle Lever forward to full engine speed.
6. Move Travel-Steering Control Levers forward to mow.

IMPORTANT: NEVER engage the PTO if the mower is plugged with grass or other material. This may cause damage to the PTO belt.

7. TO STOP MOWER BLADES – disengage PTO Switch.

TO OPERATE ON HILLS



CAUTION: Do not drive up or down hills with slopes greater than 10° and do not drive across any slope.

- Use a slow speed before starting up or down hills.
- Avoid stopping or changing speed on hills.
- If slowing is necessary, move Travel-Steering Control Levers to slower position.
- If stopping is absolutely necessary; use Travel-Steering Control Levers to hold machine on hill as it may roll down the hill in neutral.
- Do not park on hills.
- To restart movement, slowly move Steering-Control Levers forward.

STOPPING

Brake Operation

This tractor uses hydrostatic braking, through the transmission, to slow the tractor.

Stopping the Ground Drive

- Bring Steering-Control Levers back toward neutral to slow the tractor.
- To stop the tractor drive, move the Steering-Control Levers into the neutral position.

Stopping the Engine

- Move throttle control to slow position and allow engine to idle for 30 seconds.

NOTE: Failure to move throttle control to slow position and allowing engine to idle before stopping may cause engine to "Backfire".

- Turn ignition key to "OFF" position and remove key. Always remove key when leaving tractor to prevent unauthorized use.

IMPORTANT: Leaving the ignition in any other position than "OFF" will cause the battery to be discharged.

NOTE: Under conditions when tractor is standing idle with the engine running, hot engine exhaust gases may cause "browning" of grass. To eliminate this possibility, always stop engine when stopping tractor on grass areas.



CAUTION: Always stop tractor completely, as described above, before leaving the operator's position for any reason.

TO TRANSPORT THE MOWER

IMPORTANT: Never push or pull (tow) the unit with another vehicle. Use a truck or trailer when transporting or transmission damage can occur.

- Disengage PTO.
- Raise attachment lift to highest position with attachment lift control.
- When pushing your tractor, be sure the transmission dump valves are OPEN.
- Do not push tractor at more than five (5) mph.
- To protect engine cover when transporting your tractor on a truck or a trailer, be sure engine cover is closed and secured to tractor. Use an appropriate means of tying hood to tractor (rope, cord, etc.).

FOR BEST MOWING RESULTS

- Mower should be properly leveled for best mowing performance. See *Deck Leveling in Service and Adjustments*.
- The left side of mower should be used for trimming.
- Drive so that clippings are discharged onto the area that has been cut. Keep the cut area to the right of the machine. This will result in a more even distribution of clippings and more uniform cut.
- When mowing large areas, start by turning to the right so the clippings will discharge away from shrubs, fences, driveways, etc. After one or two rounds, mow in the opposite direction making left hand turns until finished.
- If grass is extremely tall, it should be mowed twice to reduce load and possible fire hazard from dried clippings. Make first cut relatively high; the second to the desired height.
- Do not mow when grass is wet. Wet grass will clog mower and leave undesirable clumps. Allow grass to dry before mowing.
- Always operate engine at full throttle when mowing to assure better mowing performance and proper discharge of material. Regulate ground speed by using the Steering Control Levers.
- When operating attachments, select a ground speed that will suit the terrain and give best performance of the attachment being used.

MULCHING OPERATION (OPTIONAL)

The special mulching blades and baffles will allow the grass clippings to be cut many times to reduce their size. As the grass falls onto the lawn, it disperses into the grass and will not be noticed. Also, the mulched grass biodegrades quickly and provides nutrients for the lawn.

- Always operate engine at full throttle when mulching to assure the best cutting action of the blades.
- For best performance, set the height of your mower deck so that no more than 1/3 of the total grass length is removed at any one time.

- Grass should be cut when it is dry, not when it is wet from dew, rain or from watering. Wet grass tends to pack inside mower pan and will not disperse evenly.
- If grass does not disperse evenly, it is possible that too much grass is being removed per cutting, grass is too wet or travel speed is too fast.
- This mulcher is not recommended for newly seeded lawns. A new lawn has much softer blades of grass and a higher moisture content. New lawns should be cut with conventional side discharge or bagging for the first few mowings.

MAINTENANCE

MAINTENANCE SCHEDULE		Before Each Use	Every 8 Hours	Every 25 Hours	Every 50 Hours	Every 100 Hours	Every Season	Before Storage
Tractor / Deck	Check Operator Presence Systems	•						
	Check for Loose Fasteners	•				•		•
	Check Parking Brake Interlock	•						
	Check Parking Brake	•	•					
	Check Tires	•	•					
	Check Blades			• ³				
	Check Battery			•				
	Clean Battery			•				•
	Check Belts					•	•	
	Clean Transaxle			•				
	Lubrication			•				•
	Cleaning		•					
Engine	Check Engine Oil Level	•	•					
	Change Engine Oil and Filter					• ^{1,2}		•
	Check Air Filter		•					
	Service Precleaner			• ²				
	Replace Paper Element					• ²		
	Inspect Muffler/Spark Arrestor				•			
	Replace Spark Plugs					•	•	
	Replace In-Line Fuel Filter						•	
	Clean Air Screen			• ²				
Clean Engine Cooling Fins					• ²			

1 - Change more often when operating under a heavy load or in high ambient temperatures.

2 - Service more often when operating in dirty or dusty conditions.

3 - Replace blades more often when mowing in sandy soil.

GENERAL RECOMMENDATIONS

Always observe safety rules when performing any maintenance.

The warranty on this tractor does not cover items that have been subjected to operator abuse or negligence. To receive full value from the warranty, operator must maintain tractor as instructed in this manual.

Some adjustments need to be made periodically to properly maintain your tractor. All adjustments in *Service and Adjustments* should be checked at least once each season.

BEFORE EACH USE

- Check engine oil level.
- Check tire pressure.
- Check operator presence and parking brake interlock systems for proper operation.
- Check for loose fasteners.
- Check seat adjustments to ensure all controls can be reached.
- Test operation of all controls.

CHECK OPERATOR PRESENCE SYSTEM

The engine should not start unless the PTO Switch is disengaged, and the Steering-Control Levers are in neutral lock position.

- When the engine is running any attempt by the operator to leave the seat without first moving the Steering-Control Levers to neutral lock position should shut off the engine.
- When the engine is running and the PTO Switch is engaged, any attempt by the operator to leave the seat should shut off the engine. The attachment clutch should never operate unless the operator is in the seat.

Do not operate tractor unless operator presence system functions as described. Contact your Ariens dealer for repair.

CHECK FOR LOOSE FASTENERS

Be certain that all hardware is tightened to the proper torque. Pay special attention to the blades, guards and safety shields.

CHECK PARKING BRAKE INTERLOCK

Any attempt to move the Steering-Control Levers out of neutral with the parking brake engaged should shut off the engine.

CHECK PARKING BRAKE

If unit rolls with parking brake engaged, parking brake must be repaired. Contact your Ariens Dealer.

CHECK TIRES

- Maintain proper air pressure in all tires. See *Specifications*.
- Keep tires free of gasoline, oil, or insect control chemicals which can harm rubber.
- Avoid stumps, stones, deep ruts, sharp objects and other hazards that may cause tire damage.

NOTE: To seal tire punctures and prevent flat tires due to slow leaks, tire sealant may be purchased from your Dealer. Tire sealant also prevents tire dry rot and corrosion.

CHECK BLADES

For best results mower blades must be kept sharp. Replace bent, worn or damaged blades.

Blade Removal



CAUTION: Moving Parts and Sharp Blades can cut or amputate body parts. Always use sturdy gloves or padding to protect hands when working with mower blades.

1. Shut off the engine and unit. Remove the ignition key. Remove the ignition wire(s) from the spark plug(s) to prevent accidental start-up.
2. Raise mower to highest position to allow access to blades.

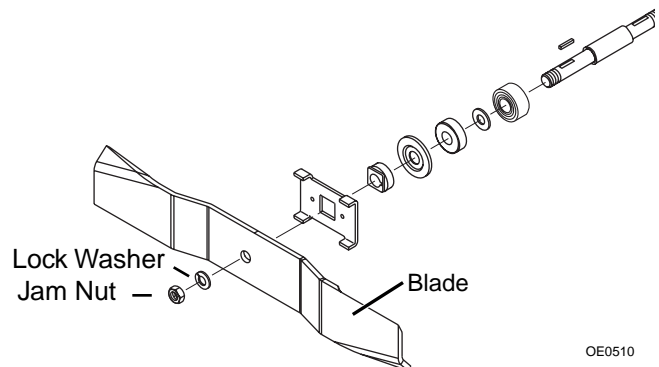

3. Remove the jam nuts, lock washers, and blades from the spindle shafts.

Blade Installation

1. Install the blades, lock washers, and jam nuts in reverse order of removal.
2. Tighten the lock nut(s) to a torque of 60 lbf-ft (82 N•m).
3. Put the ignition wire(s) back on the spark plug(s).

Sharpening Mower Blades

NOTE: We do not recommend sharpening blades, but if you do, be sure the blade is balanced.

An unbalanced blade will cause excessive vibration and eventual damage to mower and engine.

1. The blade can be sharpened with a file or on a grinding wheel. Do not attempt to sharpen while on the mower.
2. Sharpen both ends of blade at original angle, removing equal amounts of material from each end to maintain proper blade balance. DO NOT grind around corner at tips of blade. When blade becomes less than 2" (5.1 cm) wide, replace blade with Ariens replacement blade only.
3. To check blade balance, use a steel bolt or pin.

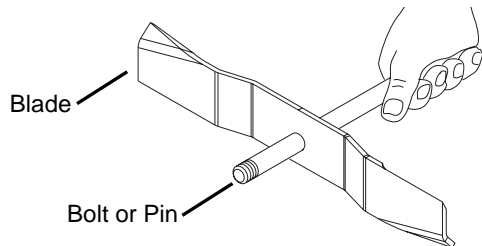

OE0500

4. Slide blade onto an unthreaded portion of the steel bolt or pin and hold the bolt or pin parallel with the ground. If blade is balanced, it should remain in a horizontal position. If either end of the blade moves downward, sharpen the heavy end until the blade is balanced.

CHECK BATTERY

Your tractor has a battery charging system which is sufficient for normal use. However, periodic charging of the battery with an automotive charger will extend its life.

- Keep battery and terminals clean.
- Keep battery bolts tight.
- Keep small vent holes open.
- Recharge at 6-10 amperes for 1 hour.

NOTE: The charging system has a port for a trickle charger on the wiring harness to the right of the starter solenoid in the engine compartment. Follow the charger manufacturer's recommended instructions for using this port.



WARNING: ELECTRICAL SHOCK may result in injury and/or damage to unit. DO NOT allow objects to come into contact with both terminals at the same time.



WARNING: REVERSE CONNECTIONS may result in sparks which can cause serious injury. ALWAYS connect positive (+) lead of charger to positive (+) terminal, and negative (-) lead to negative (-) terminal. ALWAYS connect positive (+) cable FIRST, and negative (-) cable SECOND.



WARNING: EXPLOSIVE GASES from battery can cause death or serious injury. ALWAYS keep open flames, sparks, or smoking materials away from batteries. POISONOUS BATTERY FLUID contains sulfuric acid and its contact with skin, eyes, or clothing can cause severe chemical burns. ALWAYS wear safety glasses and protective gear near battery. DO NOT TIP any battery beyond a 30° angle in any direction. ALWAYS keep batteries out of reach of children.



WARNING: Battery posts, terminals and related accessories contain lead and lead compounds, chemicals known to the State of California to cause cancer and reproductive harm. Wash hands after handling.

Battery Electrolyte First Aid

Follow First Aid directions for any contact with battery fluid.

- **External Contact:** Flush with water.
- **Contact with Eyes:** Flush with water for at least 15 minutes and get medical attention immediately!
- **Internal Contact:** If swallowed, drink large quantities of water. Follow with Milk of Magnesia, beaten egg or vegetable oil. Get medical attention immediately!

IMPORTANT: In case of internal contact, DO NOT induce vomiting.

CLEAN BATTERY

Corrosion and dirt on the battery and terminals can cause the battery to "leak" power.

- Remove battery. (See *Battery Removal and Installation*)
- Rinse the battery with plain water and dry.
- Clean terminals and battery cable ends with wire brush until bright.
- Coat terminals with grease or petroleum jelly.
- Reinstall battery.

Battery Removal and Installation

Remove battery before service.

To remove the battery from the unit:

1. Tip seat forward.
2. Put deck in lowest position.

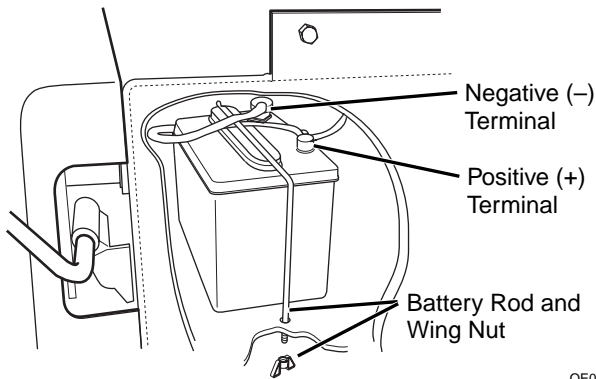

OE0152

3. Remove wing nut from the Battery Rod and remove the rod.
4. Disconnect the negative (-) cable first.
5. Disconnect the positive cable (+) second.
6. Lift the battery out of the unit and place battery on a bench or other well ventilated area where an acid spill will not create damage.
7. When service is finished, reinstall battery into unit and connect positive (+) cable first, then negative (-) cable.

CHECK BELTS

- Check belts for deterioration or wear and replace if necessary. Replace belts to accommodate belt stretch and wear in the traction drive or mower drive. Refer to *Service and Adjustments* for procedures.

CLEAN TRANSAXLE

- Keep transaxles free from buildup of dirt and chaff which can restrict cooling.

LUBRICATION

- Apply Stens Hi-Temp Grease or equivalent to the lube fittings on idler pivots.
- Grease the fittings on the front wheel spindles, the idler arms, and the steering controls every 50 hours of operation.

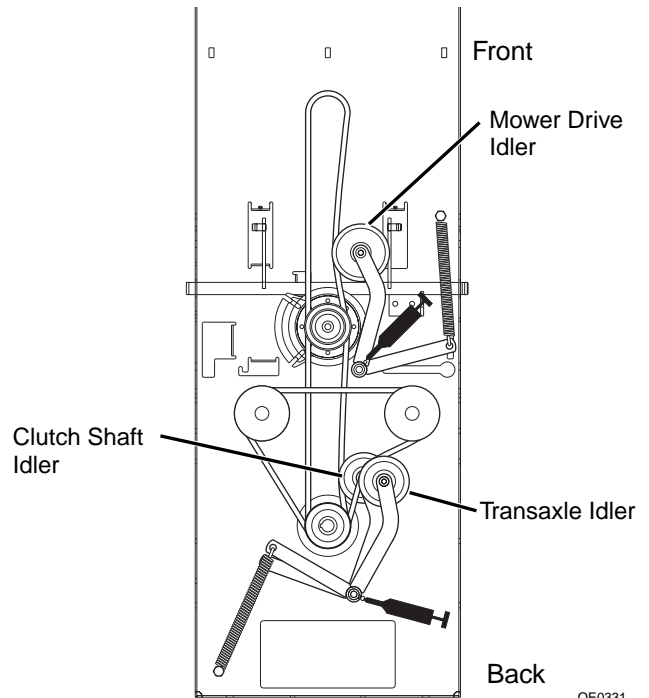

OE0331

915013 with Serial Numbers Less Than 10,500

Other Units with Serial Numbers Less Than 1,000

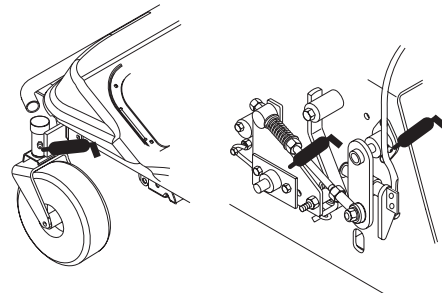

OE0700

All Other Units

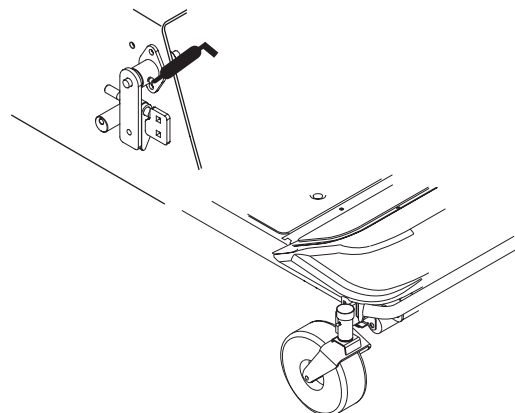

OE0701

CLEANING

- Clean engine, battery, seat, deck, etc. of all dirt and debris with a brush or cloth. Do not use solvents, harsh cleaners or abrasives.

- Remove packed grass and debris from under mower deck.
- Keep finished surfaces and wheels free of all gasoline, oil, etc.
- Protect painted surfaces with automotive type wax. Lightly coat unpainted surfaces with spray lubricant and wipe off excess with soft cloth.

IMPORTANT: Never spray unit with water or store unit outdoors. Water can seep into sealed bearings, which are sealed against dirt and debris only, causing reduced component life.

ENGINE

To access engine:

1. Unhook Engine Cover latch.
2. Lift rear of cover and slide out. Set cover aside.
3. To replace cover: Slide front of cover into slot.
4. Insert the back edge of cover into its support bracket.
5. Hook Engine Cover latch securely.

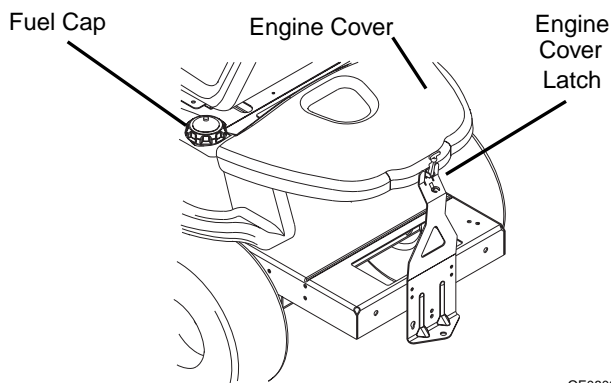

OE0800

CHECK ENGINE OIL LEVEL

Check the crankcase oil level before starting the engine and after each eight (8) hours of operation. Tighten oil fill cap/dipstick securely each time you check the oil level. See Engine Manual for detailed instructions.

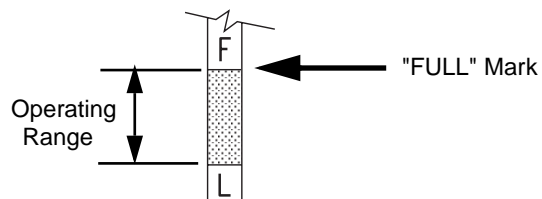

OE0380

IMPORTANT: To prevent extensive engine wear or damage, always maintain the proper oil level. Never operate the engine with the oil level below the "L" mark or over the "F" mark on the dipstick.

CHANGE ENGINE OIL AND FILTER

- Only use high quality detergent oil rated with API service classification SF or SG. Select the oil's SAE viscosity grade according to your expected environmental temperature.
- See Engine Manual for detailed instructions.

CHECK AIR FILTER

This engine is equipped with a replaceable, high density paper air cleaner element and an oiled, foam precleaner.

Check the air cleaner daily or before starting engine. Check for buildup of dirt and debris around the air cleaner system. Keep this area clean. Also check for loose or damaged components. Replace all bent or damaged air cleaner components.

Your engine will not run properly with a dirty air filter.

See Engine Manual for detailed instructions on changing the air filter.

IMPORTANT: Operating the engine with loose or damaged air cleaner components could allow unfiltered air into the engine causing premature wear and engine failure.

INSPECT MUFFLER/SPARK ARRESTOR

Inspect muffler and (if equipped) spark arrester. Replace muffler if corroded, as it could create a fire hazard and/or damage.

REPLACE SPARK PLUGS

See Engine Manual for detailed instructions.

REPLACE IN-LINE FUEL FILTER

The fuel filter should be replaced once each season. If fuel filter becomes clogged, obstructing fuel flow to carburetor, replacement is required. See Engine Manual for detailed instructions.

CLEAN AIR SCREEN

Air screen must be kept free of dirt and chaff to prevent engine damage from overheating. Clean with a brush or cloth to remove dirt and chaff. Do not clean with a forceful spray of water because water could contaminate fuel system. See Engine Manual for detailed instructions.

CLEAN ENGINE COOLING FINS

To ensure proper cooling, make sure the grass screen, cooling fins and other external surfaces of the engine are kept clean at all times. See Engine Manual for detailed instructions.

IMPORTANT: Operating the engine with a blocked grass screen, dirty or plugged cooling fins, and/or engine shroud removed will cause engine damage due to overheating.

SERVICE AND ADJUSTMENTS



CAUTION: Before performing any service or adjustments:

- Turn PTO switch "OFF".
- Park mower on a hard, flat, level surface.
- Place steering control levers in neutral lock (fully outward) position.
- Set parking brake.
- Turn ignition switch "OFF" and remove key.
- Wait for blades and all moving parts to stop.
- Disconnect spark plug wire(s) from spark plug(s) and place wire(s) away from plug.

TO REMOVE 48" AND 40" MOWER DECK

1. Turn off engine, engage parking brake and allow hot parts to cool.
2. Place center deck lift handle in lowest (1) position.



WARNING: AVOID injury from stored energy in lift assist spring. DO NOT unlock attachment lift lever with mower deck removed. ALWAYS engage Attachment Lift Lever Lock when removing mower deck. See *Operation*.

3. Engage Attachment Lift Lever Lock. Pull handle out and rotate down 90°. Handle will spring into locked position.

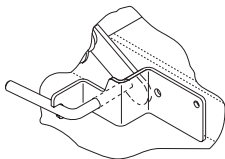

Disengaged

OE0730

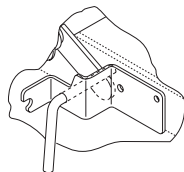

Engaged

OE0720

4. Disconnect mower belt idler spring from bolt under frame.
5. Remove mower belt from mower pulley and electric clutch.
6. Remove hair pins and washers holding height adjusters to lift arm, and unhook height adjusters from lift arm.
7. Unhook the rear hangers from the holes in the bottom of the frame.
8. Remove cotter pin and washer from end of front pin.
9. Slide front pin out to release front lift arms from frame.

10. Slide mower from under tractor. Mower is easier to remove from the right side of the tractor.

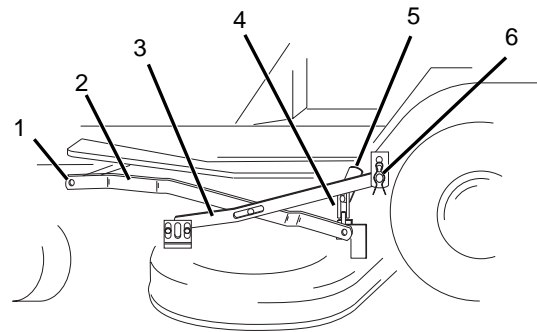

OE0170

- | | |
|-------------------|--------------------|
| 1. Front Pin | 4. Height Adjuster |
| 2. Front Lift Arm | 5. Lift Lever Hook |
| 3. Rear Hanger | 6. Hair Pin |

TO INSTALL 48" AND 40" MOWER DECK

1. The center deck lift handle should be in the lowest (1) position with the Attachment Lift Lever Lock engaged.



WARNING: AVOID injury from stored energy in lift assist spring. DO NOT unlock attachment lift lever with mower deck removed. ALWAYS engage Attachment Lift Lever Lock when removing mower deck. See *Operation*.

2. Push mower under unit. Mower is easier to push in from right side of the tractor.
3. Slide a washer down to tabbed end of front pin.
4. Align holes in front lift arms with slots at front of frame and slide front pin through arms and frame.
5. Secure front pin with washer and cotter pin.
6. Hook rear hanger into the holes in the bottom of the frame on both sides.
7. Secure rear hangers with hair pins.
8. Hook the height adjusters onto the lift arm.
9. Secure height adjusters with washers and hair pins.
10. Install mower belt onto mower pulley and electric clutch.
11. Connect mower belt idler spring to bolt under frame.

TO REMOVE 42" MOWER DECKS

1. Turn off engine, engage parking brake and allow hot parts to cool.
2. Place center deck lift handle in lowest (1) position.



WARNING: AVOID injury from stored energy in lift assist spring. DO NOT unlock attachment lift lever with mower deck removed. ALWAYS engage Attachment Lift Lever Lock when removing mower deck. See *Operation*.

- Engage Attachment Lift Lever Lock. Pull handle out and rotate down 90°. Handle will spring into locked position.

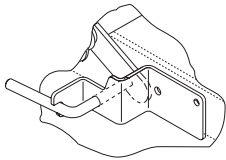

Disengaged

OE0730

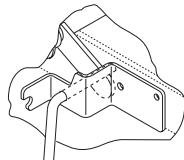

Engaged

OE0720

- Loosen nut on rod link at front of tractor. It is not necessary to remove it entirely.
- Release rod link locking brackets from rod link at front of deck.
- Remove clutch to deck belt from drive pulley.
- Remove hair pins and clevis pins from rear deck link.
- Remove hair pins and washers from deck lift.
- Pivot right front wheel to allow deck to slide past.
- Slide mower from under tractor. Mower is easier to remove from the right side of the tractor.

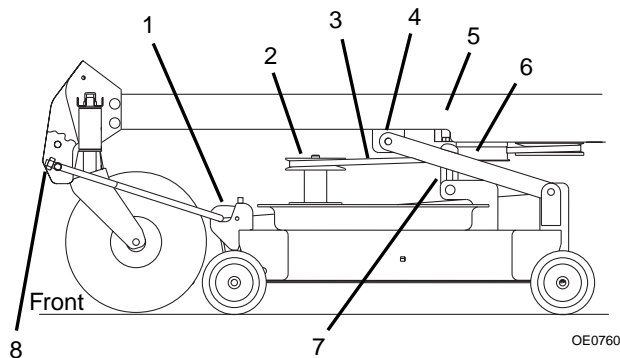

OE0760

- | | |
|---|------------------------------------|
| 1. Rod Link Locking Brackets | 5. Mower Frame |
| 2. Drive Pulley | 6. Idler |
| 3. Clutch to Deck Belt | 7. Adjuster Link Washer & Hair Pin |
| 4. Rear Deck Link Hair Pin & Clevis Pin | 8. Rod Link Nut |

TO INSTALL 42" MOWER DECKS

- The center deck lift handle should be in the lowest (1) position with the Attachment Lift Lever Lock engaged.



WARNING: AVOID injury from stored energy in lift assist spring. DO NOT unlock attachment lift lever with mower deck removed. ALWAYS engage Attachment Lift Lever Lock when removing mower deck. See *Operation*.

- Push mower deck under tractor from right side of unit.
- Attach deck lift with washers and hair pins.
- Attach rear deck link with clevis pins and hair pins.
- Place clutch to deck belt around drive pulley, idler and clutch pulley.
- Place rod link in holding brackets at front of deck and engage rod link locking brackets.
- Tighten nut on end of rod link until it is snug.

MOWER HEIGHT ADJUSTMENT

CUTTING HEIGHT SETTINGS CHART

Setting	Cut grass length
1	1-3/8" (35 mm)
2	2" (51 mm)
3	2-3/4" (70 mm)
4	3-1/2" (89 mm)
5	4-3/8" (111 mm)

To Adjust 48" or 40" Deck:

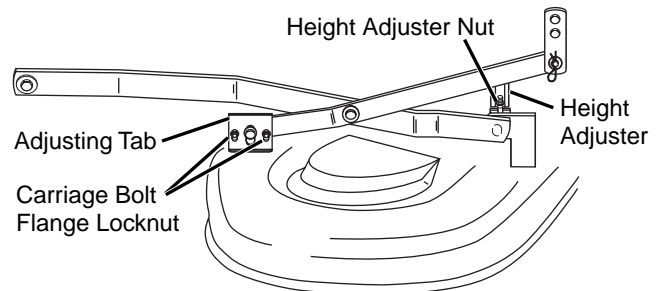

OT0770

- To adjust mower height, place mower in the number three (3) position.
- Loosen height adjuster nuts.
- Remove hair pins and washers holding height adjusters to lift arm and unhook height adjusters from lift arm.
- Turn height adjusters *equally* clockwise to raise mower, or *equally* counterclockwise to lower mower. Adjust for a height of 2-3/4" (7 cm) from ground to blade tip.
- Hook height adjusters onto lift arm and check for correct height. If not correct, continue to turn height adjusters until height is correct.

6. Tighten height adjuster nuts.
7. Secure height adjusters with washers and hair pins.

To Adjust 42" Deck:

1. Place mower in the number three (3) position.
2. Place anti-scalp rollers in highest position so they do not touch the ground during adjustment.
3. Turn the nuts on the bottom of the adjusters *equally* until the blade tips are 2 3/4" (7 cm) from the ground.
4. Reset anti-scalp rollers to match desired attachment position.

TO LEVEL MOWER

Adjust the mower while tractor is parked on level ground or driveway. Make sure tires are properly inflated (See *Specifications*). If tires are overinflated or underinflated, you can not properly adjust your mower.

To Check Side to Side Level

1. Position unit on a smooth, flat, level surface. Set proper tire pressure.
2. Position blade(s) side to side; measure distance of blade tips to floor at right and left side of mower pan. Rotate blade(s) 180° and check again. The measurement should be equal within 1/8 inch (3 mm) side to side.

NOTE: To make measuring distance from blade to ground easier, obtain a wood block about 1 inch square by 5 inches long (2.54 cm² x 12.7 cm). Wrap the entire block with masking tape. Hold block in vertical position with its lower tip on ground. Push block against cutting edge of blade so as to make a mark on tape. Pull the block away and with a ruler measure the distance from lower block tip to mark.

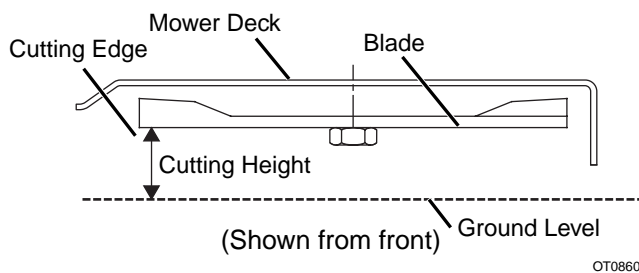

To Adjust Side to Side Level (48" and 40" Decks)

1. Loosen height adjuster nuts.
2. Remove hair pins and washers holding height adjusters to lift arm and unhook height adjusters from lift arm.
3. On low side: Turn height adjuster nut clockwise on low side of mower pan to raise low side. Raise low side one half the measured difference in height between the low side and the high side.

On high side: Turn height adjuster nut counterclockwise to lower high side the other one half of the height difference.

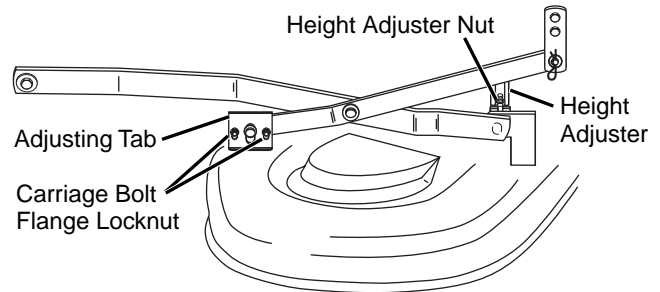

4. Hook height adjusters onto lift arm and check side to side level. If not level, continue to turn height adjusters until deck is level side to side.
5. Tighten height adjuster nuts.
6. Secure height adjusters with washers and hair pins.

To Adjust Side to Side Level (42" Deck)

1. Place anti-scalp rollers in highest position so they do not touch the ground during adjustment.
2. Put height adjustment lever in the number three (3) position.
3. With a 1/2" open-end wrench, adjust the nuts on the bottom of the adjuster link until each end of the blade is 2-3/4" (7 cm) from the ground within 1/16" (1.5 mm).
4. Reset anti-scalp rollers to match desired attachment position.

MOWER PITCH

Proper blade pitch is when the blade tip, measured from the bottom surface, is 1/8" to 1/4" (3–6 mm) lower at front of mower deck than when same tip is at rear of mower deck.

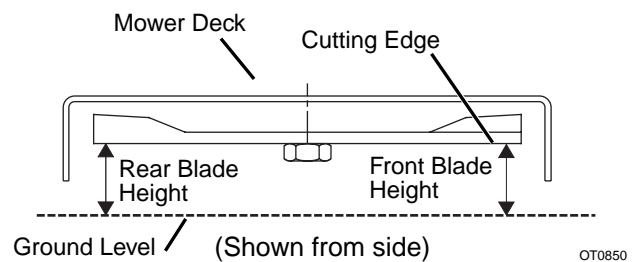

To Adjust 48" and 40" Decks

To adjust pitch, loosen flange lock nuts and slide adjusting tabs up or down to achieve proper pitch.

To Adjust 42" Deck

To adjust pitch, turn nut on rod link at front of mower deck. Turn the nut clockwise to raise the front of the deck. Turn the nut counterclockwise to lower the front of the deck.

BELTS



WARNING: MOVING PARTS can cut or amputate body parts. ALWAYS wait for moving parts to stop before unit maintenance or service.

Clutch to Deck Belt Replacement (48" and 40" Decks)



CAUTION: USE PROPER SPRING TOOL when releasing and installing springs. Stored energy in springs can cause injury.

1. Disconnect main idler spring from bolt under frame.
2. Remove belt from electric clutch and drive pulley.
3. Install new belt onto drive pulley and electric clutch, checking for belt alignment and clearance.
4. Connect main idler spring to frame.

48" Mower Deck Diagram

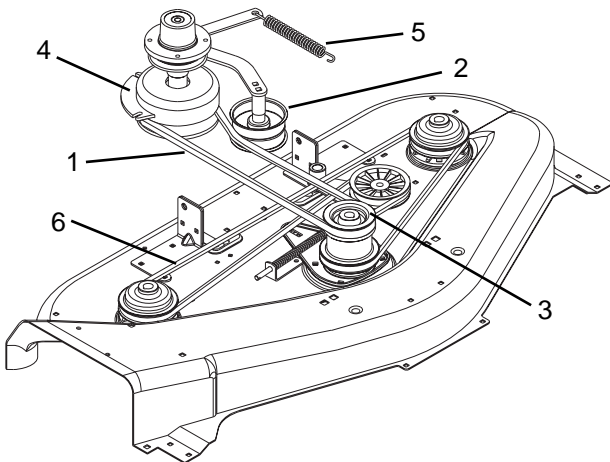

- | | |
|------------------------|--------------------|
| 1. Clutch to Deck Belt | 4. Electric Clutch |
| 2. Clutch Idler Arm | 5. Idler Spring |
| 3. Drive Pulley | 6. Mower Deck Belt |

OT0830

40" Mower Deck Diagram

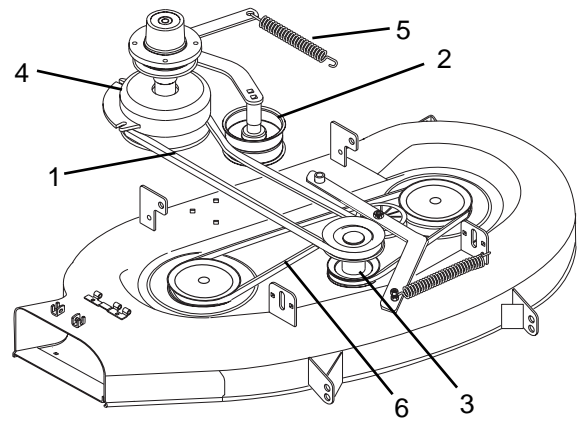

- | | |
|------------------------|--------------------|
| 1. Clutch to Deck Belt | 4. Electric Clutch |
| 2. Clutch Idler Arm | 5. Idler Spring |
| 3. Drive Pulley | 6. Mower Deck Belt |

OE0820

Clutch to Deck Belt Replacement (42" Decks)



CAUTION: USE PROPER SPRING TOOL when releasing and installing springs. Stored energy in springs can cause injury.

1. Disconnect idler spring from the frame.

IMPORTANT: This requires a spring hook. DO NOT use a side cutter pliers. If the correct tool is not available, loosen the front nut until the belt can be easily removed from the deck.

2. Remove belt from electric clutch and drive pulley.
3. Install new belt onto drive pulley and electric clutch, checking for belt clearance.
4. Connect idler spring to frame.

42" Mower Deck Diagram

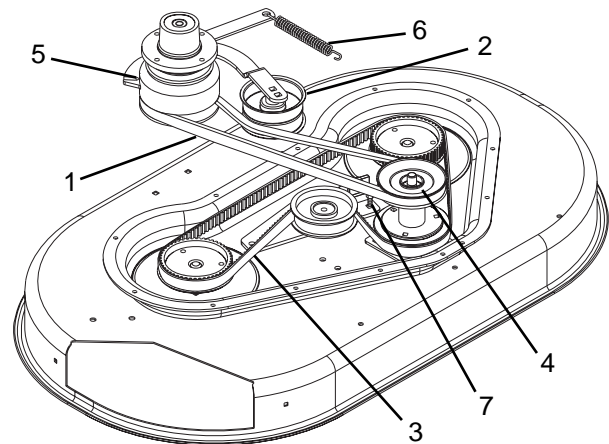

- | | |
|------------------------|--------------------|
| 1. Clutch to Deck Belt | 5. Electric Clutch |
| 2. Clutch Idler Arm | 6. Idler Spring |
| 3. Mower Deck Belt | 7. Idler Eye-Bolt |
| 4. Drive Pulley | |

OE0820

Mower Deck Belt Replacement (48" and 40" Deck)

1. Remove mower drive belt (see procedure above).
2. Detach mower deck from tractor. See *To Remove 48" and 40" Mower Deck in Service and Adjustments*.
3. Remove belt covers.
4. Remove mower idler spring.
5. Remove mower deck belt.
6. Install new mower deck belt onto mower sheaves and idler.
7. Install mower idler spring.
8. Reinstall belt covers.
9. Reinstall mower deck to tractor. See *To Install 48" and 40" Mower Deck in Service and Adjustments*.
10. Reinstall mower drive belt.

Mower Deck Belt Replacement (42" Deck)

1. Detach mower deck from tractor. See *To Remove 42" Mower Deck in Service and Adjustments*.
2. Remove belt covers.
3. Loosen two nuts on idler arm, one turn each. ①

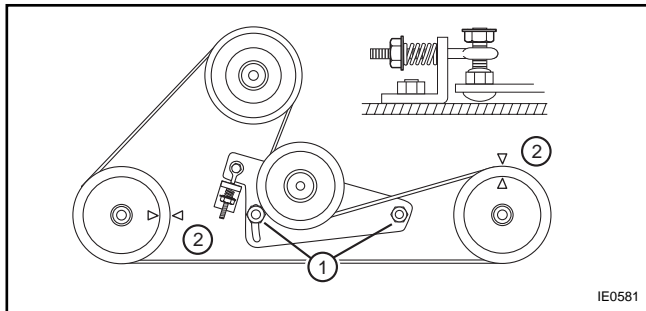

4. Remove the lock nut and spring from the eye-bolt.
5. Rotate idler arm out of the way, and remove mower deck belt.
6. Match marks on mower sheaves to marks on deck to properly align blades. ②
7. Install new belt and move idler arm back into position, taking care to maintain blade alignment.
8. Reinstall spring and lock nut onto eye bolt.
9. Tighten lock nut on eye-bolt until exposed thread is 1/2"– 5/8" (13–16 mm) long.

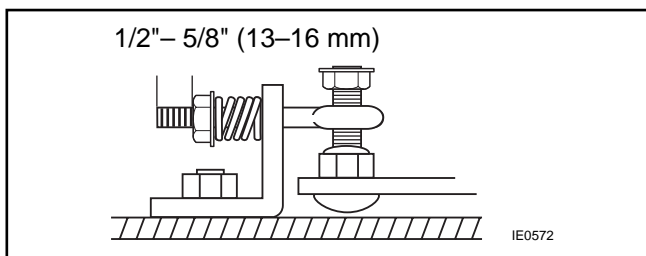

10. Tighten nuts on idler arm securely. ①

IMPORTANT: Idler arm is **not** a floating idler. **Arm must not** move once belt tension is set or belt/blade damage will result.

11. Reinstall belt covers.
12. Reinstall mower deck to tractor. See *To Install 42" Mower Deck in Service and Adjustments*.

Transaxle Belt Replacement

1. Remove transaxle idler spring from bolt under frame.
2. Remove belt from transaxles.
3. Remove belt from engine sheave.
4. Install new belt onto transaxles, then engine sheave. Check for belt alignment and clearance.
5. Connect transaxle idler spring.

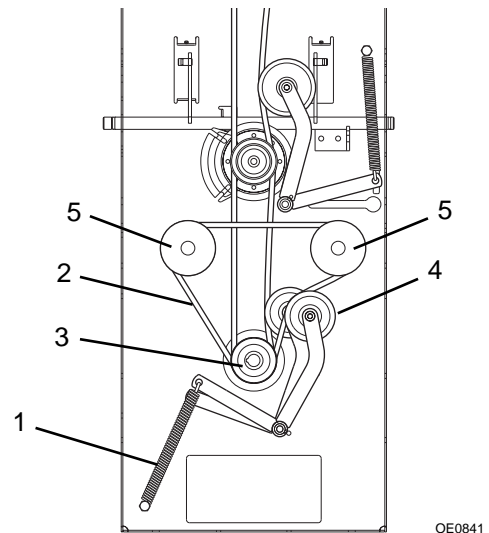

- | | |
|---------------------------|---------------------------|
| 1. Transaxle Idler Spring | 4. Transaxle Idler Spring |
| 2. Transaxle Belt | 5. Transaxles |
| 3. Engine Sheave | |

Clutch Shaft Belt Replacement

1. Remove transaxle belt (see procedure above).
2. Remove clutch shaft idler spring from frame.
3. Remove clutch shaft belt from engine sheave.
4. Remove clutch shaft belt from clutch sheave.

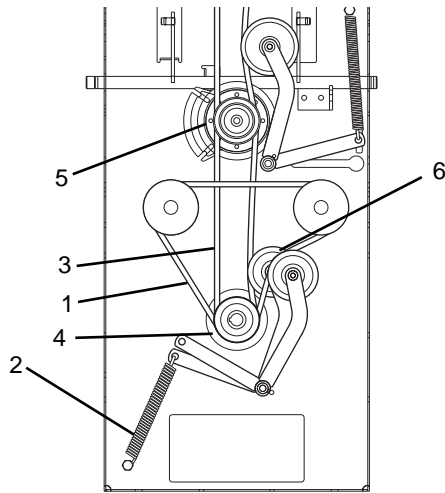

OE0841

- | | |
|------------------------------|------------------|
| 1. Transaxle Belt | 4. Engine Sheave |
| 2. Clutch Shaft Idler Spring | 5. Clutch Sheave |
| 3. Clutch Shaft Belt | 6. Clutch Idler |

5. Install new belt onto clutch sheave, then engine sheave. Check for belt alignment and clearance.
6. Connect clutch shaft idler spring to bolt.
7. Reinstall transaxle belt.

ADJUSTMENTS

Neutral Adjustment (Speed Control Lever)

NOTE: 915013 with Serial Numbers Less Than 10,500.
Other Units with Serial Numbers Less Than 1,000.

1. Stop the engine. Remove the ignition key. Push the PTO knob into the "OFF" position.



CAUTION: PREVENT personal injury! ALWAYS MAKE CERTAIN that jack(s) or blocks used are stable, strong and will support the weight of the unit.

2. Place jack(s) under rear transaxles only. If jack(s) are not available, place support blocks under both transaxles at the rear of the unit.
3. Raise the rear drive wheels off the floor. Remove side shrouds. Set aside.
4. Start the engine and run it at part throttle.
5. Loosen the two lock nuts holding the Speed Control Arm.
6. Rotate Flange Bushing until the wheel stops rotating.
7. Lock the Speed Control Arm in place by tightening the two lock nuts.
8. Repeat procedure for other side of unit.
9. Reinstall side shrouds.

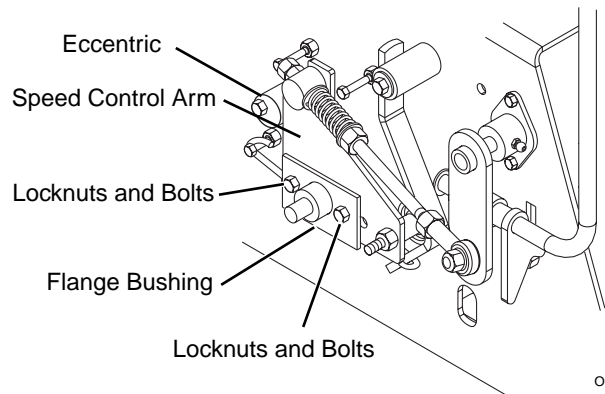

OE0082

Neutral Adjustment (Speed Control Lever)

NOTE: All Other Units

1. Stop the engine. Remove the ignition key. Push the PTO knob into the "OFF" position.



CAUTION: PREVENT personal injury! ALWAYS MAKE CERTAIN that jack(s) or blocks used are stable, strong and will support the weight of the unit.

2. Lock steering levers in neutral. (See *Neutral Lock in Operation.*)
3. Place jack(s) under rear transaxles only. If jack(s) are not available, place support blocks under both transaxles at the rear of the unit.
4. Raise the rear drive wheels off the floor. Remove side shrouds. Set aside.
5. Loosen nuts on transaxle linkage.
6. Start the engine and run it at part throttle. Transaxle should set neutral automatically (wheels do not spin).

NOTE: If transaxle does not set neutral, contact your Ariens Dealer for repair.

7. Shut off engine.
8. Tighten nuts on transaxle linkage without moving the pivot arm or transaxle rod.
9. Repeat procedure for other side of unit.

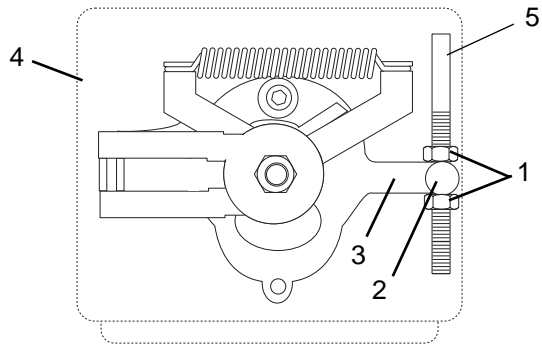

- | | |
|----------------------|----------------------|
| 1. Nuts | 4. Transaxle Housing |
| 2. Transaxle Linkage | 5. Transaxle Rod |
| 3. Pivot Arm | |

OE0084

915013 with Serial Numbers Less Than 10,500.

Other Units with Serial Numbers Less Than 1,000.

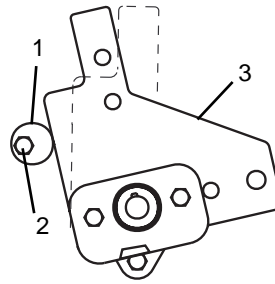

Shorter Travel

1. Eccentric
2. Bolt

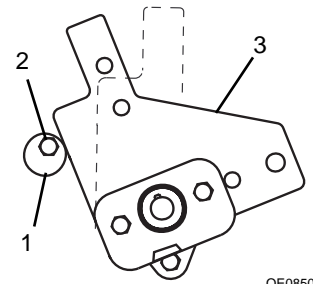

Longer Travel

3. Speed Control Arm

OE0850

ADJUSTING THE UNIT TO TRACK STRAIGHT

The primary reason the unit may not track straight is incorrect or unbalanced tire air pressure. First, check and adjust tire pressure. Increase pressure on the side the unit tracks toward. DO NOT exceed maximum recommended tire pressure. See *Specifications*.

If adjusting tire air pressure does not solve the tracking problem, the steering control lever travel may need to be adjusted.

To check steering control levers:

With the engine off, push the steering control levers to their full forward position. If one lever travels farther than the other, they need to be adjusted.

To adjust:

1. Remove side shrouds. Set aside.
2. Loosen bolts which attach the eccentric to the seat support. Do not remove the bolts.
3. Rotate eccentric to adjust the travel of the speed control arm. The thicker portion of the eccentric shortens the distance the steering control lever will travel forward. The thinner portion of the eccentric lengthens the distance the steering control lever will travel forward.

All Other Units

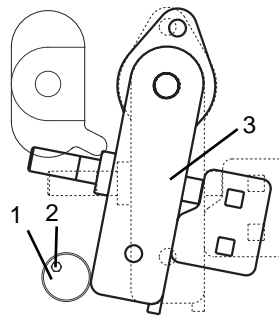

Shorter Travel

1. Eccentric
2. Bolt

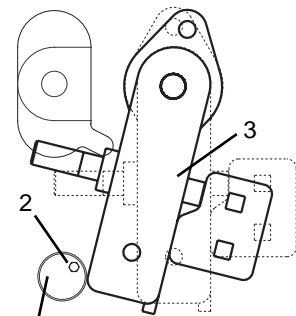

Longer Travel

3. Speed Control Arm

OE0900

4. Adjust the rotation of the eccentrics on one or both sides of the unit so that the steering control levers align in the full forward position.
5. Tighten the eccentric's bolts.
6. Reinstall the side shrouds.

ADJUSTING REVERSE TRACKING

NOTE: 915013 with Serial Numbers More Than 10,499. Other Units with Serial Numbers More Than 1,000.

A bolt attached to the frame adjusts reverse steering lever travel.

To check steering control levers:

With the engine off, pull the steering control levers to their full rearward position. If one lever travels farther than the other, they need to be adjusted.

To adjust:

1. Remove side shrouds. Set aside.
2. Loosen flange nut holding adjustment bolt to the frame.

- Slide the bolt down the slot to increase lever travel.
Slide the bolt up the slot to decrease lever travel.
- Tighten flange nut.
- Recheck lever travel. Repeat steps 2-4 as needed.
- Replace side shrouds.

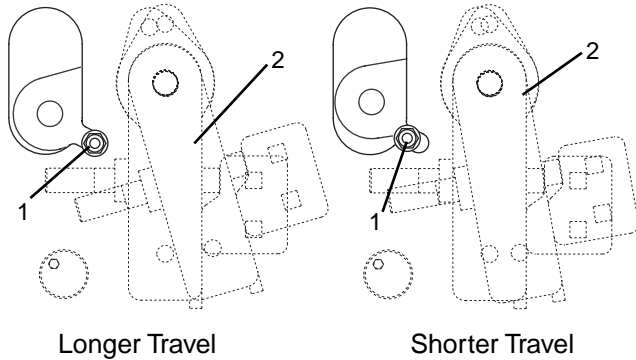

- Adjustment Bolt
- Speed Control Arm

OE0920

SEAT ADJUSTMENT

Lift up and tilt seat forward to locate seat adjustment bolts on the seat plate. Loosen the bolts. Slide operator seat forward or rearward as desired. Retighten bolts.

ANTI-SCALP ROLLERS (42" DECK)

Rollers are intended to prevent lawn scalping, not to control cutting height.

For proper operation, adjust the anti-scalp rollers to the same or higher than mower cutting height. For example, when mowing at the number three (3) height position, the anti-scalp rollers must be adjusted to their number three (3) or higher position.

Deck Rollers

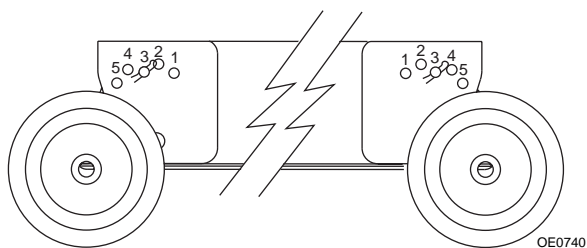

OE0740

Deck Rollers

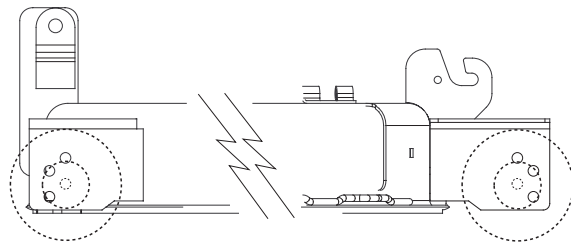

OE0910

TO START ENGINE WITH A WEAK BATTERY



CAUTION: Lead-acid batteries generate explosive gases. Keep sparks, flame and smoking materials away from batteries. Always wear eye protection when around batteries.

If your battery is too weak to start the engine, it should be recharged. (See "BATTERY" in *Maintenance*.)

If "jumper cables" are used for emergency starting, follow "Jump Starting" procedure.

IMPORTANT: Your tractor is equipped with a 12 volt negative grounded system. The other vehicle must also be a 12 volt negative grounded system. Do not use your tractor battery to start other vehicles.

Jump starting, battery charging or replacement is required when the starter motor will not crank the engine.

To Jump Start Engine:

- Ensure battery is not frozen. If the fluid is frozen, remove battery from unit and allow it to thaw before charging.
- The unit used for jump starting should have a 12 volt battery with at least 500 cold cranking amperes and a negative grounded system.



WARNING: TRACTOR MOVEMENT can result in death or serious injury. NEVER jump start directly to the starter or starter solenoid. Tractor can move forward or backward and injure the person jump starting tractor.

- Connect the positive (+) jumper cable to the positive terminal of the discharged battery.
- Connect the other end of the same jumper cable to the positive (+) terminal of the booster battery.
- Connect one end of the second jumper cable to the negative (-) terminal of the booster battery.
- Make the final jumper cable connection to the engine block or the furthest ground point away from the discharged battery.

7. Follow "Starting" and "Shut-Off" steps in *Operation*.
8. Remove jumper cables in the reverse order that you connected them. Remove cable from: the ground point, then the negative (-) terminal of the booster battery, then the positive (+) terminal of the booster battery, and finally the positive (+) terminal of the discharged battery.

INTERLOCKS AND RELAYS

Loose or damaged wiring may cause your tractor to run poorly, stop running, or prevent it from starting.

Check wiring. See "ELECTRICAL SCHEMATIC" in the *Parts Manual*. Contact your Ariens Dealer.

TO REPLACE FUSE

Replace with 30 amp automotive-type plug-in fuse. The fuse holder is located under seat support near right rear tire.

ENGINE

See the Engine Manual for specific information on maintenance, repair, or adjustments. Contact your Ariens Dealer or an authorized engine manufacturer's service center for more information.

STORAGE

Prepare your tractor for storage at the end of the season or if the tractor will not be used for 30 days or more.



CAUTION: Never store the tractor with gasoline in the tank inside a building where fumes may reach an open flame or spark. Allow the engine to cool before storing in any enclosure.

TRACTOR / DECK

IMPORTANT: Never spray unit with water or store unit outdoors.

Remove all dirt, grease, leaves, etc. Store in a clean, dry area.

- Check entire tractor (See "CLEANING" in the *Maintenance* section of this manual).
- Inspect and replace belts, if necessary. (See "BELT REPLACEMENT" in the *Service and Adjustments* section of this manual).
- Lubricate as shown in *Maintenance*.
- Be sure that all nuts, bolts and screws are securely fastened. Inspect moving parts for damage and wear. Replace if necessary.
- Touch up all rusted or chipped paint surfaces; sand lightly before painting.

BATTERY

- Fully charge the battery for storage.
- After a period of time in storage, battery may require recharging.
- To help prevent corrosion and power leakage during long periods of storage, battery cables should be disconnected and battery cleaned thoroughly (See *To Clean Battery and Terminals* in *Maintenance*).
- After cleaning, leave cables disconnected and place cables where they cannot come in contact with battery terminals.
- If battery is removed from tractor for storage, do not store battery directly on concrete or damp surfaces.

ENGINE



CAUTION: Never cover tractor while engine and exhaust areas are still warm.

See the Engine Manual for detailed instructions on storage.

ATTACHMENTS & ACCESSORIES

See your authorized Ariens dealer to add these optional accessories.

71500300	Front Weight Kit*
71500700	Rear Weight Kit
71500900	Wheel Spacer Kit*
71501000	Tire Chain Kit
71501100	Headlight Kit*
71501200	Hourmeter Kit*
71501300	42" Mulching Kit*
73600100	40" Mulching Kit
81500300	40" Snow Head
81500500	2 Bucket Bagger - 40" Deck
81500600	Front Blade
81500800	2 Bucket Bagger - 42" Deck*
81500900	2 Bucket Bagger - 48" Deck

* Available for 915308

SERVICE PARTS

Be sure to always use genuine Ariens parts to keep your unit running like new.

Part no.	Qty	Description
03123751	3	Blade - 48" Deck
01584500	2	Blade - 42" Deck
01585000	2	Blade - 42" Deck (CE)
03624700	2	Blade - 40" Deck
07237500	1	Cog Belt - 42" Deck
07235500	1	Belt - 40" Deck
07234400	1	Belt - 48" Deck
07213600	1	Transmission Belt
07234500	1	Clutch to Deck Belt - 48" Deck
07239500	1	Clutch to Deck Belt - 42" Deck
07234300	1	Clutch to Deck Belt - 40" Deck

TROUBLESHOOTING

PROBLEM	CAUSE	CORRECTION
Engine will not start or loses power	<ol style="list-style-type: none"> 1. Steering-Control Levers not locked in neutral. 2. Attachment clutch is engaged. 3. Out of fuel. 4. Engine not "CHOKED" properly. 5. Engine flooded. 6. Bad spark plug. 7. Dirty air filter. 8. Dirty fuel filter. 9. Water in fuel. 10. Loose or damaged wiring. 11. Carburetor out of adjustment. 12. Weak or dead battery. 13. Blown fuse. 14. Corroded battery terminals. 15. Faulty ignition switch. 16. Faulty solenoid or starter. 17. Faulty operator presence switch. 18. Cutting too much grass /too fast. 19. Buildup of grass, leaves and trash under mower. 20. Low oil/dirty oil. 21. Spark plug wire loose. 22. Dirty engine air screen/fins. 23. Dirty/clogged muffler. 24. Engine valves out of adjustment. 	<ol style="list-style-type: none"> 1. Move both levers fully outward. 2. Disengage attachment clutch. 3. Fill fuel tank. 4. See "Engine Starting And Shut-Off" in Operation section. 5. Wait several minutes before attempting to start. 6. Replace spark plug. 7. Clean/replace air filter. 8. Replace fuel filter. 9. Drain fuel tank and carburetor, refill tank with fresh gasoline and replace fuel filter. 10. Check all wiring. 11. Contact your Ariens Dealer. 12. Recharge or replace battery. 13. Replace fuse. 14. Clean battery terminals. 15. Contact your Ariens Dealer. 16. Contact your Ariens Dealer. 17. Contact your Ariens Dealer. 18. Set in "HIGHER CUT" position. 19. Clean underside of mower. 20. Check oil level/change oil. 21. Connect and tighten spark plug wire. 22. Clean engine air screen/fins. 23. Clean/replace muffler. 24. Contact your Ariens Dealer.
Engine hard to start	<ol style="list-style-type: none"> 1. Dirty air filter. 2. Bad spark plug. 3. Weak or dead battery. 4. Dirty fuel filter. 5. Stale or dirty fuel. 6. Carburetor out of adjustment. 	<ol style="list-style-type: none"> 1. Clean/replace air filter. 2. Replace spark plug. 3. Recharge or replace battery. 4. Replace fuel filter. 5. Drain fuel tank and refill with fresh gasoline. 6. Contact your Ariens Dealer.
Engine clicks but will not start	<ol style="list-style-type: none"> 1. Weak or dead battery. 2. Corroded battery terminals. 3. Loose or damaged wiring. 4. Faulty solenoid or starter. 	<ol style="list-style-type: none"> 1. Recharge or replace battery. 2. Clean battery terminals. 3. Check all wiring. 4. Contact your Ariens Dealer.
Unit does not track straight	<ol style="list-style-type: none"> 1. Improper air pressure in tires. 2. Eccentrics out of alignment. 	<ol style="list-style-type: none"> 1. Check and adjust tire pressure. DO NOT exceed maximum recommended tire pressure. (See <i>Specifications</i>.) 2. See "Adjusting the Unit to Track Straight" in <i>Adjustments</i> Section.

SPECIFICATIONS

Model Number	915013	915020	915021	915022	915023	915308
Description	1742 EZR	1540 EZR	1740 EZR	1742 EZR	2048 EZR	1742 EZR
Engine Manufacturer	Briggs & Stratton					Briggs & Stratton 311777-0154-E1
Engine Power - HP (KW)	17 (12.7)	15 (11.2)	17 (12.7)		20 (15)	12.3 (9.2)
Engine Operating Fast Idle Speed - RPM	3200 ±100					2500±50
Engine Displacement - cu. in. (cc)	30.6 (502)	30.5 (500)	30.6 (502)	40 (656)	40 (656)	30.6 (502)
Crankcase Capacity - qt (Liters)	1.4 (1.3)			1.6 (1.5)		1.4 (1.3)
Fuel	See Engine Manual for type and grade					
Fuel Tank Capacity - gal (Liters)	3.5 (13.3)					
Length - in (cm)	71.9 (182.6)			75.8 (192.5)		
Width - in (cm)	50 (127)				60 (152.4)	50 (127)
Height - in (cm)	44.7 (114)					
Weight - lbs (Kg)	660 (299)	630 (286)		670 (304)	660 (299)	665 (301)
Front Wheel Size - in (cm)	11.0 x 4.00-5 (28 x 10.2 - 12.7)					
Rear Wheel Size - in (cm)	18 x 8.50-8 (45.7 x 21.6 - 20.3) 4 ply					
Tire Pressure	15 to 20 psi (103 to 138 kN/m ²)					
Towing Capacity – Tongue Weight Max. capacity - lbs (Kg)	30 (13) 250 (113)					
Oper. Ear Sound Pressure (L _{pa}) dB _A	Not Applicable					87
Vibration Measure (m/s ²)						
@ Operator Hands X axis Y axis Z axis						<2.5 <2.5 <2.5
@ Operator Feet X axis Y axis Z axis						<.5 <.5 .55
@ Whole Body X axis Y axis Z axis						<.5 <.5 .60



Ariens Company
655 West Ryan Street
P.O. Box 157
Brillion, WI 54110-0157
920-756-2141
Fax 920-756-2407
www.ariens.com

2 Year Limited Warranty

Ariens Company warrants to the original purchaser that consumer products manufactured by Ariens Company will be free from defects in material and workmanship for a period of two (2) years after the date of purchase, and will repair any defect in material or workmanship, and repair or replace any defective part, subject to the conditions, limitations and exclusions set forth herein.

The two year duration of this warranty applies only if the product is put to ordinary, reasonable, and usual personal, family, or household uses. If the product is put to any business, commercial, or industrial use such as, but not limited to, commercial landscaping, mowing or snow removal services, or golf course or park maintenance, or agricultural or farmstead use, then the duration of this warranty is ninety (90) days after the date of purchase, or one (1) year after the date of purchase if the product is labeled as a Professional/Commercial Product. If any product is rented or leased, then the duration of this warranty is ninety (90) days after the date of purchase.

Genuine Ariens service parts and accessories not purchased with the product covered by this warranty, but which are later purchased and used with that product, are warranted to be free from defects in material and workmanship for a period of ninety (90) days after date of purchase, and Ariens Company will repair or replace any such part or accessory free of charge, except for labor, during that period.

This warranty is subject to the following conditions, limitations, and exclusions:

This warranty is valid only if the following conditions are met:

- The warranty registration card must be completed and returned to Ariens Company.
- The purchaser must perform maintenance and minor adjustments explained in the owner's manual.
- The purchaser must promptly notify Ariens Company or an authorized Ariens service representative of the need for warranty service.

This warranty is subject to the following limitations:

- The purchaser must transport the product to and from the place of warranty service.
- Warranty service must be performed by an authorized Ariens service representative. (To find an authorized Ariens service representative, contact Ariens Company at the number or address above.)
- Batteries are warranted only for a period of twelve (12) months after date of purchase, on a prorated basis. For the first ninety (90) days of the warranty period, a defective battery will be replaced free of charge. If the applicable warranty period is more than 90 days, Ariens Company will cover the prorated cost of any defective battery, for up to twelve(12) months after the date of purchase.

The following items are not covered by this warranty:

- Engines and engine accessories are covered only by the warranty made by the engine manufacturer, and are not covered by this warranty.
- If the product is equipped with a Peerless gearbox and/or transmission, the gearbox and/or transmission are covered only by the warranty made by Peerless, and are not covered by this warranty.
- If the product is equipped with a Hydro-Gear transmission and/or Hydro-Gear drive components, the Hydro-Gear transmission and/or drive components are covered only by the warranty made by Hydro-Gear, and are not covered by this warranty.
- Parts that are not genuine Ariens service parts are not covered by this warranty.
- Shoes, runners, scraper blades, shear bolts, string trimmer height guide, mower blades, mower vanes, trimmer line, headlights, light bulbs, are not covered by this warranty.
- Any defect which is the result of misuse, alteration, improper assembly, improper adjustment, neglect, or accident, is not covered by this warranty.
- Products which were not purchased in the United States, Puerto Rico, or Canada are not covered by this warranty. In all other countries, contact place of purchase.

LIMITATION OF REMEDY AND DAMAGES

Ariens Company's liability under this warranty, and under any implied warranty that may exist, is limited to repair of any defect in workmanship, and repair or replacement of any defective part. Ariens Company shall not be liable for incidental, special, or consequential damages (including lost profits). Some states do not allow the exclusion of incidental or consequential damages, so the above limitation or exclusion may not apply to you.

DISCLAIMER OF FURTHER WARRANTY

Ariens Company makes no warranty, express or implied, other than what is expressly made in this warranty. If the law of your state provides that an implied warranty of merchantability, or an implied warranty of fitness for particular purpose, or any other implied warranty, applies to Ariens Company, then any such implied warranty is limited to the duration of this warranty. Some states do not allow limitations on how long an implied warranty lasts, so the above limitation may not apply to you.

This warranty gives you specific legal rights, and you may also have other rights which vary from state to state.

Form: ALW2-112701



Ariens Company
655 West Ryan Street
P.O. Box 157
Brillion, WI 54110-0157
920-756-2141
Fax 920-756-2407
www.ariens.com