



Sno-Thro®

Owner/Operator Manual

Models

932102 - 520

932103 - 624

932310 - 624

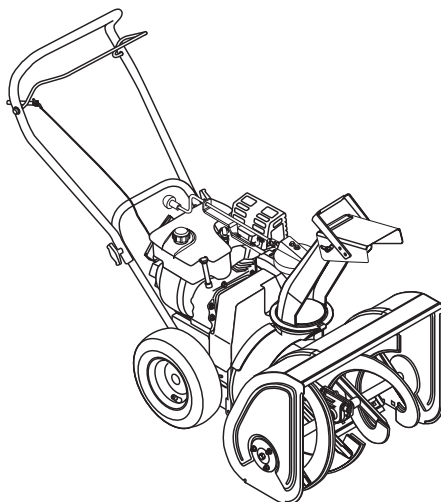

(GB) ENGLISH

(F) FRANÇAIS

(E) ESPAÑOL

Transfer
model &
serial number
label from
product
registration
here.

Coller l'autocollant du
modèle et du numéro de
série dans cet encadré.

Transferir aquí la etiqueta
del modelo y número de
serie del registro del
producto.

03243800D 5/02
Supersedes 03243800,A, B, C
Printed in USA



Ariens Company
655 West Ryan Street
P.O. Box 157
Brillion, Wisconsin 54110-0157
USA
Telephone (920) 756-2141
Facsimile (920) 756-2407



MODEL CERTIFICATE OF CONFORMITY ISSUED BY THE MANUFACTURER
CERTIFICAT DE CONFORMITÉ DU MODÈLE DÉLIVRÉ PAR LE FABRICANT
MODELL-KONFORMITÄTSBESCHEINIGUNG AUSGESTELLT DURCH DEN HERSTELLER
CERTIFICATO DI CONFORMITÀ DEL MODELLO RILASCIATO DAL PRODUTTORE
CERTIFICADO DE CONFORMIDAD DEL MODELO PROVISTO POR EL FABRICANTE
MODELLSERTIFIKAT FOR OVERENSSTEMMELSE UTSTEDT AV FABRIKANT
TILLVERKARENS MODELLCERTIFIKAT OM ÖVERENSSTÄMMELSE
VALMISTAJAN ANTAMA VAKUUTUS MALLIN MÄÄRÄYSTEN MUKAISUUDESTA

We the undersigned, - Je soussigné, - Mit meiner Unterschrift - Wij de ondergetekenden, - Il sottoscritto, - El abajo firmante - Undertegnede, - Undertecknaren av detta dokument, - Me, allekirjoittaneet,

ARIENS COMPANY, certify that the Snow Thrower - certifie que le chasse-neige - bestätigen daß die Schneefräse, verklaren dat de sneeuwschuiver - certifica che lo spazzavere - certifica que el quita nieves - attesterer at sneslynger - bevitner at snøfreseren - försäkrar att snöslungan, vakuutamme, että lumilinko:

Category: **WALK BEHIND SNOW THROWER**

Make and Trade Name: **ARIENS**

Model: 932310

Serial # Range: 001900 and up

conform to the specifications of directive 98/37/EC and EC directive (EMC) 89/336/EEC as amended by EC directive 92/31/EEC, and 2000/14/EC.

conforme aux spécifications de la directive 98/37/CE et de la directive CE (EMC) 89/336/CE modifiée par la directive CE 92/31/CE et 2000/14/CE.

entsprechen den Spezifikationen der EU-Richtlinien 98/37/EC und (EMC) 89/336/EEC, abgeändert durch EU-Richtlinien 92/31/EEC und 2000/14/EC.

conforme alle specifiche contenute nella direttiva 98/37/EC e nella direttiva CE (EMC) 89/336/EEC, come emendata dalla direttiva 92/31/EEC e dalla 2000/14/EC.

conforme a las especificaciones de la directiva 98/37/EC y directiva EC (EMC) 89/336/EEC como se enmienda por la directiva EC 92/31/EEC, y 2000/14/EC.

følг spesifikasjonene i direktiv 98/37/EF og EF-direktiv (EMC) 89/336/EØF som er endret av EF-direktiv 92/31/EØF, og 2000/14/EF.

uppfyller specifikationerna i direktiv 98/37/EC och EC-direktiv (EMC) 89/336/EEC med ändringar enligt EC-direktiv 92/31/EEC och 2000/14/EC.

vastaa direktiiviä 98/37/EC ja EC direktiiviä (EMC) 89/336/EEC, joissa EC direktiivin 92/31/EEC ja 2000/14/EC muutokset.

Representative Measured Sound Power Level Niveau de puissance acoustique représentatif Repräsentativer gemessener Geräuschpegel Livello di potenza sonora rappresentativo rilevato Nivel de potencia acústica representativo medido Representativt målt lydeffektivité Representativ uppmått ljudnivå Edustava, mitattu äänen tehotaso	Guaranteed Sound Power Level - Niveau garanti de puissance acoustique Garantierter Geräuschpegel Livello di potenza sonora garantito Nivel de potencia acústica garantizado Garantert lydeffektivité Garanterad ljudnivå Taattu äänen tehotaso
100 dB _A	102 dB _A

Stated Sound Power Levels are established following Annex V "Internal Control of Production" of directive 2000/14/EC and assessment procedure EN-ISO 3744:1995.

Les déclarations de niveau de puissance acoustique sont établies conformément à l'Article V « Contrôle interne de la production » de la directive 2000/14/CE et de la procédure d'examen EN-ISO 3744:1995.

Die angegebenen Geräuschpegel wurden gem. Anhang V „Internal Control of Production“ (Interne Produktionskontrolle) der Richtlinie 2000/14/EC und dem Bewertungsverfahren EN-ISO 3744:1995 festgelegt.

Il livello della potenza sonora dichiarata viene rilevato in base all'Appendice V del "Controllo Interno di Produzione" della direttiva 2000/14/CE e della procedura di rilevamento EN-ISO 3744:1995

Los niveles de potencia acústica formulados se establecen siguiendo el anexo V "Control interno de producción" de la directiva 2000/14/EC y el procedimiento de evaluación EN-ISO 3744:1995.

Lydeffektiviténe er fastsatt etter tillegg V om "Intern produksjonskontroll" i direktiv 2000/14/EC og vurderingsprosedyren EN-ISO 3744:1995."

Fastställda ljudnivåer har etablerats enligt bilaga V, "Internal Control of Production", i direktiv 2000/14/EC och utvärderingsprocedur EN-ISO 3744:1995.

Mainitut äänen painetasot on mitattu direktiivä 2000/14/EC vastaavasti ("Internal Control of Production") mittausmenetelmä EN-ISO 3744:1995 käyttäen.

May, 2002 Manager of Product Conformance
Date/Datum/Data/ Position/Qualité/Functie/Qualifica/
Fecha/Dato/Päiväys Puesto/Stilling/Titel/Arvo



Signature/Unterschrift/
Handtekening/Firma/
Underskrift/Underskrift
Handtekening/
Underskrift/Allekirjoitus



The engine exhaust from this product contains chemicals known to the State of California to cause cancer, birth defects or other reproductive harm.

CONTROLS AND FEATURES

ENGLISH

1. Attachment Clutch Bail
2. Chute Control Lever
(932102)
Chute Crank
(932103, 310)
3. Muffler Guard
4. Chute Deflector
5. Discharge Chute
6. Housing
7. Throttle
8. Spark Plug and Wire
9. Oil Fill and Dipstick
10. Fuel Tank and Cap
11. Primer Bulb
12. Electric Starter (932103)
13. Recoil Start
14. Ignition Switch
15. Choke
16. Scraper Blade
17. Auger
18. Impeller
19. Belt Cover

FRANÇAIS

1. Commande d'embrayage de l'outil
2. Levier de commande de la goulotte (932102)
Manivelle de la goulotte (932103, 310)
3. Garant du silencieux
4. Défecteur de la goulotte
5. Goulotte d'évacuation
6. Carter
7. Commande des gaz
8. Bougie et fil
9. Tube de remplissage en huile et jauge
10. Réservoir de carburant et bouchon
11. Poire d'amorçage
12. Démarreur électrique (932103)
13. Lanceur à rappel
14. Clé de contact
15. Starter
16. Lame racleuse
17. Rotor
18. Turbine
19. Couvercle de la courroie

ESPAÑOL

1. Asa del embrague del accesorio
2. Palanca de control de la tolva (932102)
Manivela de la tolva (932103, 310)
3. Protector del silenciador
4. Deflector de la tolva
5. Tolva de descarga
6. Alojamiento
7. Acelerador
8. Bujía y cable
9. Llenado de aceite y varilla medidora
10. Depósito del combustible y tapón
11. Perilla de cebado
12. Arranque eléctrico (932103)
13. Arranque de retroceso
14. Llave de encendido
15. Estrangulador
16. Cuchilla raspadora
17. Sinfín
18. Propulsor
19. Cubierta de la correa

932103
932310

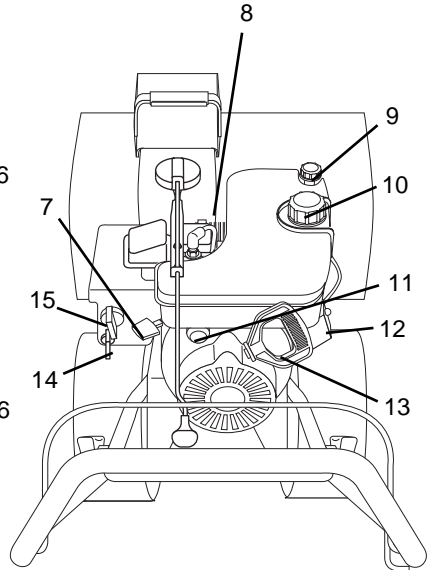
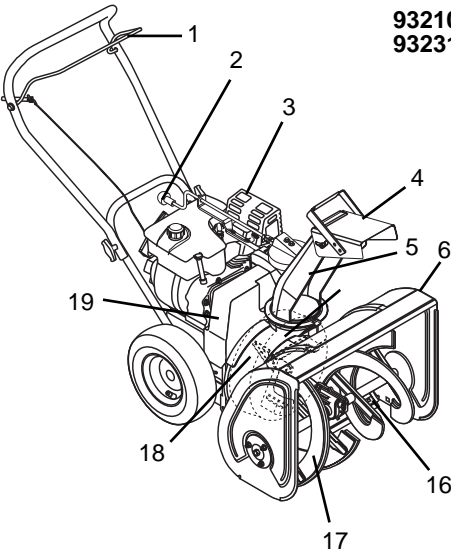

OS1746
OS2071

932102

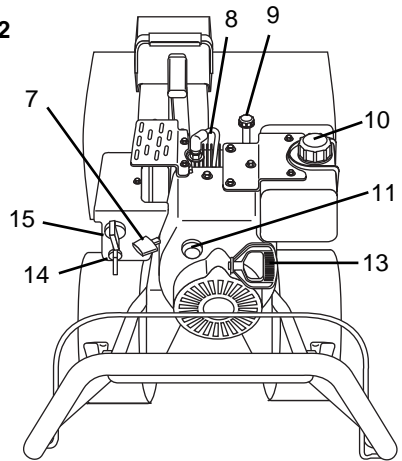
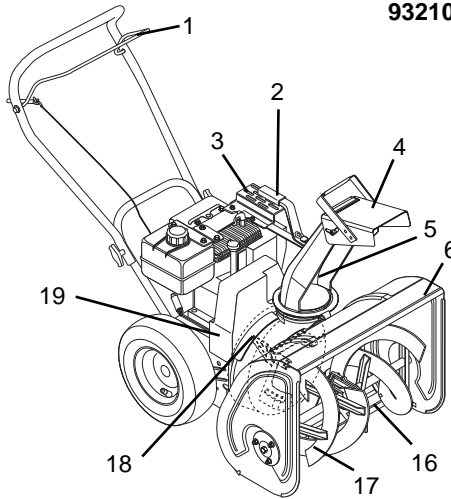

17

Figure 1

OS2080
OS1911

TABLE OF CONTENTS

Controls and Features	4	Storage.....	21
Safety	7	Troubleshooting	21
Assembly.....	11	Accessories.....	22
Operation.....	13	Service Parts	22
Maintenance	16	Specifications	23
Service & Adjustments.....	18	Warranty.....	24

INTRODUCTION

THE MANUAL

Before operation of unit, carefully and completely read your manuals. The contents will provide you with an understanding of safety instructions and controls during normal operation and maintenance.

All reference to left, right, front, or rear are given from operator standing in operation position and facing the direction of forward travel.

MODEL AND SERIAL NUMBERS

When ordering replacement parts or making service inquiries, know the Model and Serial numbers of your unit and engine.

Numbers are located on the product registration form in the unit literature package. They are printed on a serial number label, located on the frame of your unit.

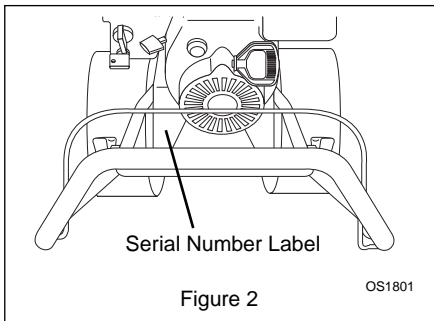

- Record Unit Model and Serial number here.

- Record Engine Model and Serial number here.

PRODUCT REGISTRATION

A warranty registration card must be filled out, signed, and returned at time of purchase. This card activates the warranty. Claims meeting requirements during limited warranty period will be honored.

UNAUTHORIZED REPLACEMENT PARTS

Use only Ariens replacement parts. The replacement of any part on this vehicle with anything other than an Ariens authorized replacement part may adversely affect the performance, durability, or safety of this unit and may void the warranty. Ariens disclaims liability for any claims or damages, whether warranty, property damage, personal injury or death arising out of the use of unauthorized replacement parts. For a brief list of replacement parts see *Service Parts* in this manual. To obtain a complete parts manual, find your model and serial number. Then go to www.ariens.com or call 1-800-678-5443.

DISCLAIMER

Ariens reserves the right to discontinue, make changes to, and add improvements upon its products at any time without public notice or obligation. The descriptions and specifications contained in this manual were in effect at printing. Equipment described within this manual may be optional. Some illustrations may not be applicable to your unit.

DELIVERY

Customer Note: If you have purchased this product without complete assembly and instruction by your retailer, it is your responsibility to:

1. Read and understand all assembly instructions in this manual. If you do not understand or have difficulty following the instructions, contact your nearest Ariens Dealer for assistance. Make sure all assembly has been properly completed.

NOTE: To locate your nearest Ariens Dealer, call 1-800-678-5443 or go to www.ariens.com on the internet.



WARNING: Improper assembly or adjustments can cause serious injury.

2. Understand all Safety Precautions provided in the manuals.
3. Review control functions and operation of the unit. Do not operate the Sno-Thro unless all controls function as described in this manual.
4. Review recommended lubrication, maintenance and adjustments.
5. Review Limited Warranty Policy.
6. Fill out Original Purchaser Registration Card and return the card to Ariens Company.

SAFETY

SAFETY ALERTS



Look for these symbols to point out important safety precautions. They mean:

Attention!



**Personal Safety Is Involved!
Become Alert!**

Obey The Message!

The safety alert symbols above and signal words below are used on decals and in this manual.

Read and understand all safety messages.



DANGER: IMMINENTLY HAZARDOUS SITUATION! If not avoided, **WILL RESULT** in death or serious injury.



WARNING: POTENTIALLY HAZARDOUS SITUATION! If not avoided, **COULD RESULT** in death or serious injury.



CAUTION: POTENTIALLY HAZARDOUS SITUATION! If not avoided, **MAY RESULT** in minor or moderate injury. It may also be used to alert against unsafe practices.

NOTATIONS

NOTE: General reference information for proper operation and maintenance practices.

IMPORTANT: Specific procedures or information required to prevent damage to unit or attachment.

PRACTICES AND LAWS

Practice usual and customary safe working precautions, for the benefit of yourself and others. Understand and follow all safety messages. Be alert to unsafe conditions and the possibility of minor, moderate, or serious injury or death. Learn applicable rules and laws in your area.

REQUIRED OPERATOR TRAINING

Original purchaser of this unit was instructed by the seller on safe and proper operation. If unit is to be used by someone other than original purchaser; loaned, rented or sold, **ALWAYS** provide this manual and any needed safety training before operation.

SAFETY DECALS AND LOCATIONS

ALWAYS replace missing or damaged Safety Decals. Refer to figure below for Safety Decal locations.

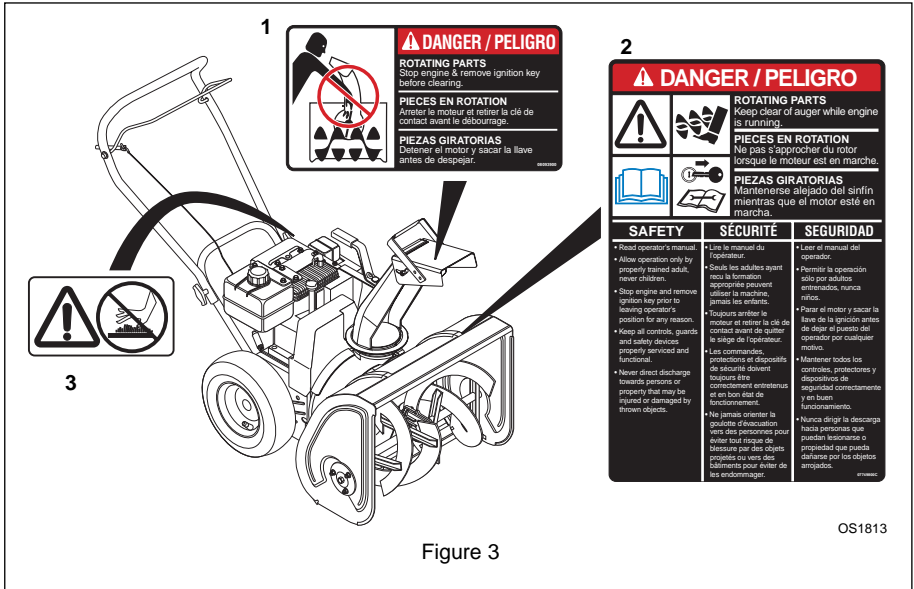

Figure 3

1. DANGER!



ROTATING PARTS

Stop engine and remove ignition key before clearing. **High speed impeller rotates below discharge opening. Wait for all moving parts to stop before removing clogs or servicing.**

- Allow operation only by properly trained adult, never children.



Stop engine and remove ignition key prior to leaving operator's position for any reason.

- Keep all controls, guards and safety devices properly serviced and functional.

- Never direct discharge towards persons or property that may be injured or damaged by thrown objects.

2. DANGER!



ROTATING PARTS

Keep clear of auger while engine is running.

3. HOT SURFACES!

SAFETY



Read Operator's Manual.



DO NOT touch parts which are hot from operation. ALWAYS allow parts to cool.

ASSEMBLY SAFETY RULES

Read, understand, and follow all safety practices in Owner/Operator Manual before assembling. Failure to follow instructions could result in personal injury and/or damage to unit.

ALWAYS remove key and/or wire from spark plug before assembly. Unintentional engine start up can cause death or serious injury.

OPERATIONAL SAFETY RULES

Walk Around Inspection

Complete a walk around inspection of unit and work area to understand:

- Work area
- Your unit
- All safety decals

Work Area

ALWAYS check overhead and side clearances carefully before operation. ALWAYS be aware of traffic when operating along streets or curbs.

Keep children and people away. Keep children out of work area and under watchful care of a responsible adult.

NEVER allow children to operate or play on or near unit. Be alert and shut off unit if children enter area.

DO NOT allow adults to operate unit without proper training.

Keep area of operation clear of all toys, pets, and debris. Thrown objects can cause injury.

Check for weak spots on docks, ramps or floors. Avoid uneven work areas and rough terrain. Stay alert for hidden hazards.

Avoid uneven and rough terrain. DO NOT operate near drop offs, ditches, or embankments. Unit can suddenly turn over if a wheel is over the edge of a cliff or ditch, or if an edge caves in.

Falling snow, fog, etc. can reduce vision and cause an accident. Operate unit only when there is good visibility and light.

Personal Safety

Only trained adults may operate unit.

Training includes actual operation.

NEVER operate unit after or during the use of medication, drugs or alcohol. Safe operation requires your complete and unimpaired attention at all times.

NEVER allow anyone to operate this unit when their alertness or coordination is impaired.

DO NOT operate unit without wearing adequate winter outer garments. Wear adequate safety gear, including safety glasses with side shields, and protective gloves. Wear proper footwear to improve footing on slippery surfaces.

DO NOT wear loose clothing or jewelry and tie back hair that may get caught in rotating parts. Protect eyes, face and head from objects that may be thrown from unit. Wear appropriate hearing protection.

Avoid sharp edges. Sharp edges can cut. Moving parts can cut off fingers or a hand.

ALWAYS keep hands and feet away from all rotating parts during operation. Rotating parts can cut off body parts.

ALWAYS keep hands away from all pinch points.

DO NOT touch unit parts which might be hot from operation. Allow parts to cool before attempting to maintain, adjust or service.

NEVER place your hands or any part of your body or clothing inside or near any moving part while unit is running.

Never direct discharge towards persons or property that may be injured or damaged by thrown objects. DO NOT use on gravel surfaces. Stay alert for hidden hazards or traffic.

DO NOT throw snow any higher than necessary.

Deflected materials can cause injury and property damage.

Always stand clear of the discharge area when operating this unit.

Fumes from engine exhaust can cause injury or death. DO NOT run engine in an enclosed area. Always provide good ventilation.

ALWAYS disengage attachment clutch bail, stop unit and engine, remove key, allow moving parts to stop before leaving operator's position for any reason.

Operation

Read, understand, and follow all instructions in the manual and on the machine before starting.

Understand:

- How to operate all controls
- The functions of all controls
- How to STOP in an Emergency

Rotating impeller can cause serious injury. DO NOT unclog unit while engine is running. When leaving operator's position for *any reason*, ALWAYS disengage auger, stop unit and engine, remove key and allow moving parts to stop.

Before starting engine, disengage control(s).

Use only approved extension cords and receptacles when starting units equipped with Electric starter. DO NOT connect electric starter cord to any wiring system that is not a three-wire grounded system.

ALWAYS allow unit and engine to adjust to outdoor temperatures before clearing snow.

Always be sure of your footing, especially when operating in reverse. Walk, never run during operation.

DO NOT operate at too fast a rate.

Slow down and turn corners slowly.

ALWAYS back up slowly. Always look down and behind before and while backing.

Disengage attachment drive when traveling from one work area to another.

Abnormal Vibrations are a warning of trouble.

Striking a foreign object can damage unit.

Immediately stop unit and engine. Remove key and wait for all moving parts to stop.

Remove wire from spark plug. Inspect unit and make any necessary repairs before restart.

Before cleaning, removing clogs or making any inspections, repairs, etc.: disengage clutch(es), stop unit and engine, remove key, allow moving parts to stop. Allow hot parts to cool.

Run unit a few minutes after clearing snow to prevent freeze-up of attachment.

Disengage attachment when not in use.

Never leave a running unit unattended.

ALWAYS shut off engine before leaving unit.

ALWAYS remove key to prevent unauthorized use.

Never carry passengers.

Check clutch and brake operation frequently.

Adjust and service as required. Adjust and service as required. All motion of auger/impeller must stop quickly when bail is released.

Hazardous Slopes

DO NOT operate on steep slopes. DO NOT clear snow across the face of slopes. Keep all movement on slopes slow and gradual. DO NOT make sudden changes in speed or direction.

DO NOT park unit on a slope unless absolutely necessary. When parking on a slope always block the wheels.

Transport

ALWAYS shut off engine, remove key and drain fuel when transporting unit on a truck or trailer.

Use extra care when loading or unloading unit onto trailer or truck.

Secure unit chassis to transport vehicle. NEVER secure from rods or linkages that could be damaged.

DO NOT transport machine while engine is running.

Cleaning

Keep unit free of ice or other debris. Clean up oil or fuel spills.

Spark Arrester

This product is equipped with an internal combustion type engine. DO NOT use unit on or near any unimproved, forest-covered or brush covered land unless exhaust system is equipped with a spark arrester meeting applicable local, state or federal laws. A spark arrester, if it is used, must be maintained in effective working order by operator.

FUEL SAFETY RULES

Fuel is highly flammable and its vapors are explosive. Handle with care. Use an approved fuel container.

NO smoking, NO sparks, NO flames. ALWAYS allow engine to cool before servicing.

NEVER fill fuel tank when engine is running or hot from operation.

NEVER fill or drain fuel tank indoors.

Replace fuel cap securely and clean up spilled fuel.

Never fill containers inside a vehicle or on a truck or trailer bed with a plastic liner. Always place containers on the ground away from your vehicle before filling.

When practical, remove gas-powered equipment from the truck or trailer and refuel it on the ground. If this is not possible, then refuel such equipment on a trailer with a portable container, rather than from a gasoline dispenser nozzle.

Keep the nozzle in contact with the rim of the fuel tank or container opening at all times until fueling is complete. Do not use a nozzle lock-open device.

If fuel is spilled on clothing, change clothing immediately.

MAINTENANCE AND SERVICE SAFETY RULES

Before cleaning, removing clogs or making any inspections, repairs, etc.: disengage clutch(es), stop unit and engine, remove key, allow moving parts to stop. Allow hot parts to cool.

Before tipping unit up onto housing, remove enough fuel so no spills will occur. Ensure unit is secure and will not tip over during maintenance.

ALWAYS keep protective structures, guards, and panels in good repair, in place and securely fastened. NEVER modify or remove safety devices.

DO NOT change engine governor settings or over-speed engine.

Fumes from engine exhaust can cause injury or death. DO NOT run engine in an enclosed area. Always provide good ventilation.

ALWAYS maintain unit in safe operating condition. Damaged or worn out muffler can cause fire or explosion.

Keep all hardware properly tightened. Check shear bolts frequently.

Maintain or replace safety and instruction labels, as necessary.

STORAGE SAFETY RULES

NEVER store with fuel in fuel tank, inside a building where any ignition sources are present.

Allow engine to cool completely.

For extended storage, clean unit thoroughly. See Engine Manual for proper storage.

ACCESSORY AND ATTACHMENT SAFETY RULES

Use only attachments or accessories designed for your unit.

Check components frequently. If worn or damaged, replace with manufacturer's recommended parts.

ASSEMBLY



WARNING: AVOID INJURY. Read and understand *Assembly* and *Fuel Safety Rules* before proceeding.

Tools Required

- Pliers
- Open-End Wrenches: 3/8, 7/16, 1/2, 9/16 in and/or Adjustable Wrench
- Tire Gauge

Handlebar

Unfold upper handlebar until it snaps into position on the lower handlebar. Tighten the handlebar knobs to secure.

Discharge Chute (932103, 310)

1. Grease discharge chute ring if not already greased (Figure 4a).
2. Remove mounting hardware and chute crank support from top of engine.
3. Slide discharge chute over opening on housing and under the retaining clip.
4. Position chute support bracket over studs.
5. Place the chute crank support on the studs, over the chute support bracket.
6. Secure chute crank and chute support brackets to studs with mounting hardware just removed.

NOTE: Make sure the discharge chute sits flush on the discharge chute ring before tightening hardware.

7. Insert the chute crank through the hole in chute crank support.
8. Remove the spring clip from the chute pinion gear, insert chute crank into pinion and secure with spring clip.

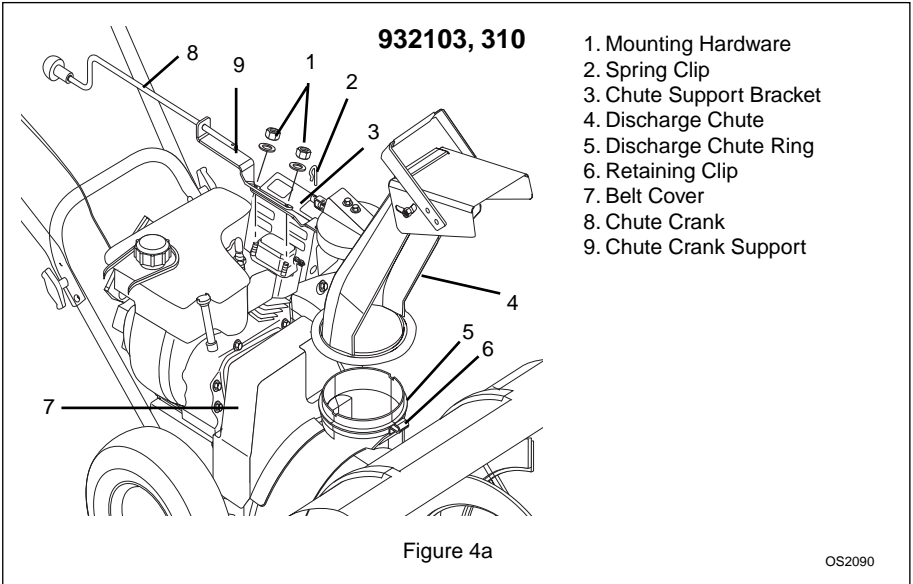

Figure 4a

OS2090

Discharge Chute (932102)

1. Grease discharge chute ring if not already greased (Figure 4b).
2. Remove mounting hardware from top of engine.
3. Slide discharge chute over opening on housing and under the retaining clip.

4. Secure chute support bracket to studs on top of engine with mounting hardware just removed.

NOTE: Be sure the discharge chute sits flush on the discharge chute ring before tightening.

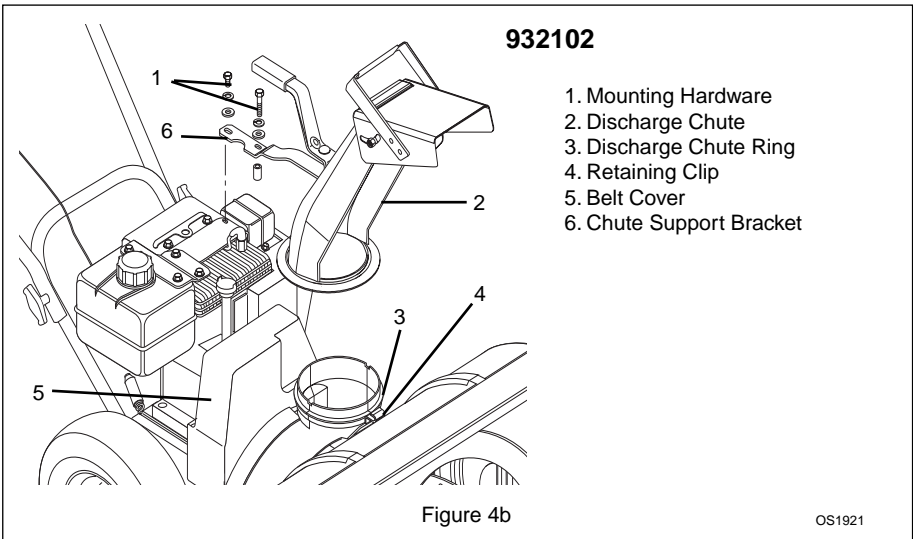

Figure 4b

OS1921

Check Attachment Clutch Cable

1. Ensure spring is connected into hole in clutch arm at rear of frame.

2. Ensure clutch cable is routed over the top of the lower handlebar.

3. Ensure Z bend end of clutch cable is connected to hole in tab on right side of clutch bail.

Check Auger Gearcase Oil

Check oil level in auger gearcase (see *Maintenance* Section).

Fill Engine Crankcase

IMPORTANT: Engines are shipped **without** oil in crankcase. Refer to Engine Manual for proper type oil and crankcase capacity.

Fill Engine Fuel Tank

Refer to Engine Manual for proper type and capacity.

Check Function of All Controls

Ensure unit runs and performs properly. Refer to *Operation* Section.

Run in Attachment Belt

1. Start unit in a well-ventilated area according to *Starting and Shut-Off* in *Operation*.
2. Engage attachment clutch lever and run attachment for about 15 minutes.
3. Stop unit, wait for all moving parts to stop, and remove spark plug wire.
4. Adjust clutch according to *Attachment Clutch/Brake Adjustment* in *Service and Adjustments*.

OPERATION



WARNING: AVOID INJURY. Read and understand *Operational* and *Fuel Safety Rules* before proceeding.

CONTROLS AND FEATURES

See Figure 1 for all Controls and Features.

Discharge Chute Deflector

ALWAYS position discharge chute deflector at a safe angle before starting engine.

DO NOT throw snow any higher than necessary.

Push deflector handle forward or down to throw snow lower. Pull deflector handle up or to the rear to throw snow higher.

IMPORTANT: If Chute Deflector does not stay in set position, adjust as directed in *Service and Adjustments*, or repair before operation.

Discharge Chute

Discharge chute rotates 220°.

ALWAYS position discharge chute in safe direction and angle, away from operator and bystanders, before starting engine.

Chute Crank (932103, 310)

IMPORTANT: If chute does not stay in set position, adjust as directed in *Service and Adjustments*, or repair before operation.

Rotate the Chute with Discharge Chute Crank Handle.

IMPORTANT: DO NOT force frozen chute controls. Start engine and run for 3-5 minutes to thaw. If still frozen, take to warm place until controls are free.

Ignition Switch

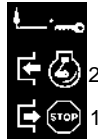

Key Switch has two positions:

1. "Stop" - Pulled Out
2. Run - Pushed In

NOTE: DO NOT twist key after inserting it.

Primer Bulb

Pushing the Primer Bulb in adds fuel for easier engine start (see *Starting and Shut Off*).



Choke Control Knob

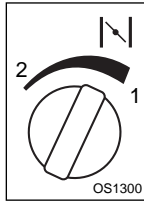

1. Choke Closed position: Choke Control chokes off air to engine for easier start.
2. Choke Open position: allows for normal operation.

IMPORTANT: Gradually open choke after engine starts.

Scraper Blade

The scraper blade allows the back of the housing to keep better contact with the surface being cleared. It also prevents damage to the housing from normal wear.

IMPORTANT: DO NOT allow Scraper Blade to wear too far or Auger/Impeller housing will become damaged.

Throttle

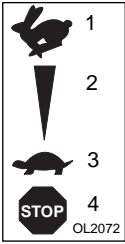

The Throttle controls the engine speed. To increase or decrease the engine speed, adjust to:

1. Fast (normal or warm starts)
2. Part-Throttle
3. Slow (cold weather starts)
4. "Stop" (engine is off)

Recoil Starter Handle

IMPORTANT: DO NOT let handle snap back against starter.

When pulled, handle will turn engine over.

Auger

The auger propels unit forward while collecting snow. Forward speeds may vary according to depth and moisture content.

Attachment Clutch Bail

Squeeze the attachment clutch bail against the handlebar to engage auger and impeller. Release bail to disengage and brake auger and impeller.

FILLING FUEL TANK



WARNING: AVOID INJURY. Read and understand *Fuel Safety Rules* in *Safety* section before proceeding.

To add fuel to fuel tank:

1. ALWAYS place unit in open or well ventilated area.
2. Stop engine and allow to cool.
3. Clean Fuel Cap and surrounding area to prevent dirt from entering Fuel Tank.
4. Remove Cap.

IMPORTANT: DO NOT use gasohol or gasoline containing alcohol. See Engine Manual for correct type and grade of fuel.

5. Fill fuel tank to within 1/2 in (1.2 cm) below bottom of filler neck with unleaded gasoline.

NOTE: Tank capacity for 932103 and 310 is 3.5 quarts (3.3 liters). Tank capacity for 932102 is 2.0 quarts (1.9 liters).

6. Replace Fuel Cap and tighten.

IMPORTANT: ALWAYS clean up any spilled fuel.

PRE-START

1. Frozen Impeller

IMPORTANT: Before starting engine, check impeller to be sure it is not frozen.

1. With key in "Stop" position, squeeze attachment clutch lever to engaged position.
2. Pull recoil starter handle.

IMPORTANT: If impeller is frozen, (cannot pull starter handle) move unit to a heated area and thaw to prevent possible damage.

2. Check Function of Clutch

Auger and impeller must stop quickly when attachment clutch bail is released.

If clutch does not engage or disengage properly, adjust or repair before operation (see *Service and Adjustments*).

3. Check Engine Fuel & Crankcase Oil



WARNING: AVOID INJURY. Read and understand *Fuel Safety Rules* in *Safety* section before proceeding.

Check and add fuel if required. If oil is not up to "FULL" mark on dipstick, add recommended oil.

See Engine Manual for detailed instructions.

STARTING AND SHUT-OFF



WARNING: FAILURE TO FOLLOW INSTRUCTIONS could result in personal injury and or damage to unit. DO NOT attempt to start your unit at this time. Read entire Owner/Operator Manual and the Engine Manual first.

IMPORTANT: Allow unit and engine to adjust to the outdoor temperatures before clearing snow. Before shut-off, run the attachment a few minutes to prevent freeze-up.

NOTE: Try out each control without the engine running to see how it works and what it does.

Manual Start

1. Turn discharge chute straight ahead.
2. Release auger clutch bail.
3. Push Primer Bulb 2 or 3 times for a cold engine.

NOTE: When temperature is below -15°F (-26°C) additional priming may be needed.

4. If engine is cold, apply choke. See Engine Manual for detailed instructions.

NOTE: A warm engine requires less choking than a cold engine.

5. Insert key into ignition switch and push into RUN position. DO NOT twist key after inserting it.
6. Grasp starter handle and pull rope out slowly until it pulls harder. Let rope rewind slowly.
7. Pull rope with a rapid continuous full arm stroke. Let rope rewind slowly.

NOTE: DO NOT allow starter handle to snap back against the starter.

8. Repeat steps 6 and 7 until the engine starts. (If engine does not start, refer to *Troubleshooting*.)
9. Adjust choke as needed.
10. Set throttle to Part Throttle or Slow position for adaptation to outside temperature. Set throttle to Fast Throttle position for normal operation.

Electric Start (120V or 240V) (932103, optional on 932102, 310)

1. Connect extension cord to prongs on starter.

IMPORTANT: Prevent damage to unit. Know voltage of your starter and only use matching outlets.

2. Plug extension cord into:
 - 240V 3-wire, grounded outlet.
 - 120V 3-wire, grounded outlet.
3. Turn discharge chute straight ahead.
4. Make sure that the attachment clutch bail is fully disengaged.
5. Push Primer Bulb 2 or 3 times for cold engine.

NOTE: When temperature is below -15°F (-26°C) additional priming may be needed.

6. Insert key into ignition switch on engine and push into "Run" position. DO NOT twist key after it is inserted.
7. If engine is cold, apply choke. A warm engine requires less choking than a cold engine. See Engine Manual for detailed instructions.
8. Set throttle to proper starting position.
9. Press starter button on engine until engine starts.

IMPORTANT: DO NOT operate starter more than 15 seconds per minute, as overheating and damage can occur. (If engine does not start, refer to *Troubleshooting*.)

10. Adjust choke as needed.
11. Disconnect power cord from outlet, then starter.

12. Set throttle to Part Throttle or Slow position for adaptation to outside temperature. Set throttle to Fast Throttle position for normal operation.

Emergency Stop

Immediately release clutch bail to stop unit in an emergency. Stop Engine, remove Key and wait for all rotating parts to stop before leaving operator's position.

Shut-Off

1. Run Impeller a few minutes after use to prevent freeze-up of Impeller.
2. Release Attachment Clutch Bail.
3. Move Throttle to the "Stop" Position.
4. Remove key.

SNOW REMOVAL

IMPORTANT: Allow unit and engine to adjust to the outdoor temperatures before clearing snow.

1. Select discharge chute and deflector position and direction.
2. Engage Attachment Clutch bail.

NOTE: The auger propels unit forward. Keep a firm grip on handlebar when engaging bail.

IMPORTANT: DO NOT overload unit capacity by attempting to clear snow at too fast a rate.

Tips for Operation

Snow is best removed as soon as possible after snow fall.

To clear an area, run unit in an overlapping series of paths. For large areas; start in the middle and throw snow to each side, so snow is not cleared more than once.

ALWAYS direct snow away from area to be cleared and with direction of the wind.

TRAVELING

To travel from one work area to another:

1. Release Attachment Clutch Bail.
2. Set Throttle to Slow position or Part Throttle position.
3. Press down the handlebars enough to raise the front of the unit slightly off surface.
4. Push unit to desired location.

TRANSPORT

ALWAYS shut off engine, remove key and drain fuel when transporting unit on a truck or trailer.

Use extra care when loading or unloading unit onto trailer or truck.

Secure unit chassis to transport vehicle.
 NEVER secure from rods or linkages that could be damaged.
 DO NOT transport machine while engine is running.

MAINTENANCE

 **WARNING: AVOID INJURY.** Read and understand *Maintenance and Service/Fuel Safety Rules* before proceeding.

SERVICE POSITION

Place unit on a flat level surface. Before tipping unit up onto housing, remove enough fuel so no spills will occur. Tip unit forward onto front of Impeller housing for service. Assure unit is secure and will not tip over. Strap and clamp onto bench if needed.

MAINTENANCE SCHEDULE

The chart below shows the recommended maintenance schedule that should be performed on a regular basis. More frequent service may be required.

MAINTENANCE SCHEDULE				
	Each Use	Every 5 hrs.	Every 25 hrs.	Yearly
Check Fasteners	•			
Check Attachment Clutch	•			
Clean Engine	•			
Check Engine Oil		•		
Change Engine Oil		*	•	
Check Tire Pressure			•	
Check Auger Gearcase			•	•
General Lubrication			•	•

* After first two hours of operation.

CHECK FASTENERS

Make sure all hardware is tightened properly.

CHECK ATTACHMENT CLUTCH

Auger / impeller must stop within 3 seconds when attachment clutch bail is released or unit damage or serious injury may result.

If clutch does not engage or disengage properly, adjust or repair before operation (see *Service and Adjustments*).

CLEAN ENGINE

Refer to Engine Manual for detailed instructions.

CHECK ENGINE OIL

The engine crankcase oil should be checked every 5 hours of operation. Oil level **MUST** be maintained in safe operating range on dipstick at all times or engine damage will result (See Engine Manual).

Park unit on a level surface. Refer to Engine Manual for detailed instructions.

CHANGE ENGINE OIL

Change oil after first two (2) hours of operation, thereafter change oil every 25 hours (more often if required). Refer to Engine Manual for detailed instructions.

NOTE: Sno-Thro has an oil drain cut-out on the left side of unit frame. Drain engine oil through this cut-out to prevent spills.

CHECK TIRE PRESSURE

Keep tires at pressure listed on the tire sidewall.

CHECK AUGER GEARCASE

IMPORTANT: Proper oil level must be maintained.

Gear cases are filled to the correct level at the factory. Unless there is evidence of leakage, no additional lubricant should be required. Check oil level each season or every 25 hours of operation.

To ensure adequate lubricant level:

1. Remove filler plug (Figure 5). Lubricant must be at least up to bottom of lubricant filler hole with unit resting on a level surface.
2. Add lubricant if required. Allow oil to drain to level of plug and replace plug.

IMPORTANT: Use only Ariens special gear lubricant L-2 (Part Number 00008000).

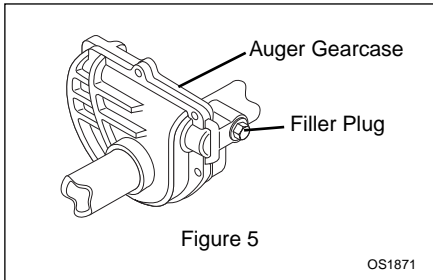

GENERAL LUBRICATION

IMPORTANT: Wipe each fitting clean before and after lubrication.

IMPORTANT: DO NOT allow grease or oil to get on belts.

NOTE: Apply Sten Mix Hi-Temp Grease or equivalent to the lubrication fittings.

Sno-Thro should be lubricated at beginning of season or every 25 operating hours (Figure 6).

Auger Shaft

To grease auger shaft, remove shear bolt nuts and shear bolts. Turn auger on shaft while applying grease at zerks fittings. Replace shear bolts.

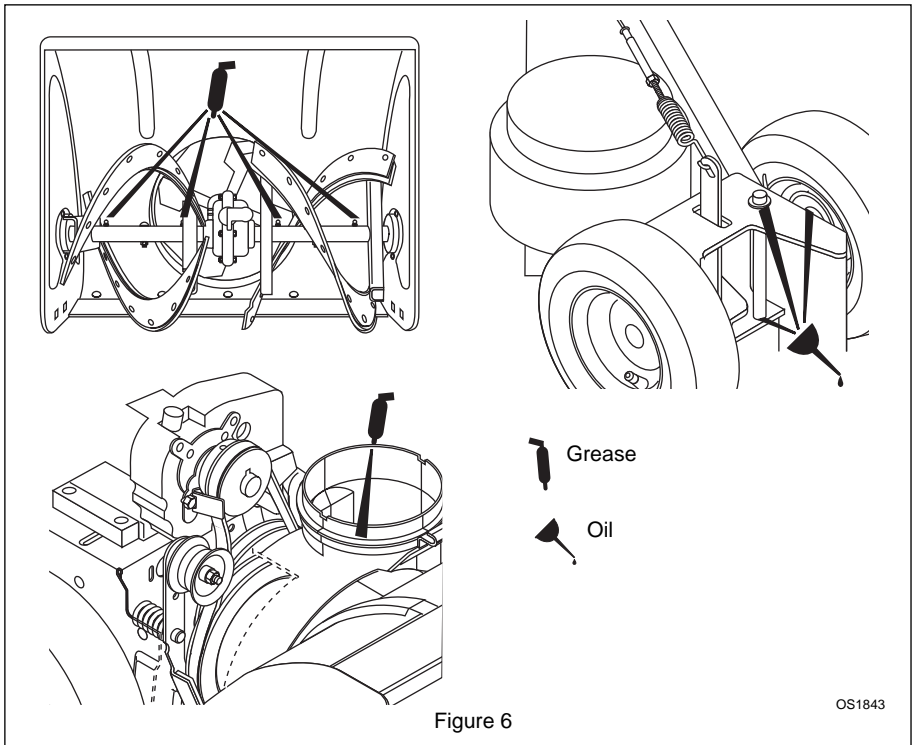

SERVICE AND ADJUSTMENTS



WARNING: AVOID INJURY. Read and understand *Maintenance and Service/Fuel Safety Rules* before proceeding.

ATTACHMENT DRIVE BELT REPLACEMENT

Remove old attachment drive belt:

1. Shut off engine, remove key, disconnect spark plug wire and allow unit to cool completely.
2. Remove belt cover (Figure 4a, 4b).
3. If equipped with chute crank, remove spring clip from chute crank and remove chute crank.
4. Remove hardware securing chute support bracket (and chute crank support, if equipped). Remove discharge chute (Figure 4a, 4b).
5. Remove attachment drive belt from engine sheave (it may be necessary to turn engine sheave using recoil starter handle) (Figure 7).



CAUTION: Always support Sno-Thro frame and blower housing when loosening the cap screws holding them together. Never loosen cap screws while unit is in service position.

6. Support Sno-Thro frame and housing.
7. Loosen bottom cap screws securing auger/impeller housing to frame (Figure 8).
8. Remove top cap screws.
9. Push down on handlebar. Unit will separate. Rest handlebar on the floor.
10. Remove belt from attachment pulley (hold brake away from belt).

Install new attachment drive belt:

1. Place new attachment belt onto attachment pulley.
2. Engage clutch bail to hold brake out of the way and tip unit back together. Secure with cap screws.
3. Place belt onto engine sheave.

4. Make sure engine sheave and attachment pulley align. If alignment is necessary, loosen attachment pulley set screws, reposition pulley and tighten set screws.
5. Reposition and secure belt fingers.

IMPORTANT: Make sure belt fingers are 1/16 in to 1/8 in (1.6-3 mm) from belt when attachment clutch is engaged.

6. Check clutch adjustment. See *Attachment Clutch/Brake*.



WARNING: AUGER / IMPELLER MUST STOP within 3 seconds when attachment clutch lever is released or unit damage or serious injury may result.

7. Replace discharge chute (and crank, if equipped).
8. Replace belt cover.

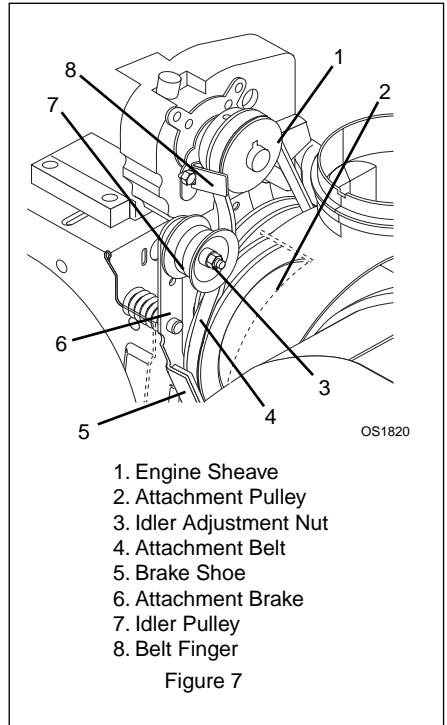

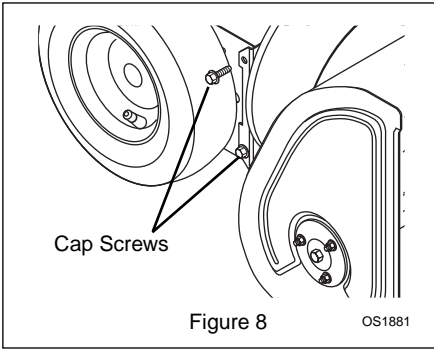

ATTACHMENT CLUTCH / BRAKE ADJUSTMENT



WARNING: IMPROPER ADJUSTMENT could result in unexpected movement of auger and impeller causing death or serious injury. Auger/impeller must stop within 3 seconds when attachment clutch bail is released.

1. Remove belt cover.
2. Check belt alignment (Figure 9).
Engine sheave and attachment pulley must align vertically. Also, belt must be centered in the idler pulley.
To move pulley or sheave:
 - a. Loosen set screw.
 - b. Slide pulley/sheave and key to desired position.
 - c. Tighten set screw.
3. Adjust cable slack.

IMPORTANT: The clutch cable must be slack when the bail is disengaged.

- a. With clutch bail disengaged, loosen jam nut on cable adjuster.
- b. Lift spring arm, but do not move idler arm.
- c. Turn adjuster body to remove all slack from the cable. Do not stretch spring or move idler arm.
- d. Release spring arm and turn back the adjuster body 5 turns (approximately 1/4 in or 6 mm). Finger tighten jam nut.
- e. Hold adjuster body with pliers and tighten jam nut with wrench.

4. Check spring length.
 - a. Measure the length of the clutch cable spring.
 - b. Engage and hold the attachment clutch bail.
 - c. Measure the length of the spring again. The spring should be 1/8-3/16 in (3-5 mm) longer when the bail is engaged.
5. Adjust spring length.
 - a. Loosen the idler adjustment nut.
 - b. To increase spring extension, move idler towards belt (Figure 7).
 - c. To decrease spring extension, move idler away from belt.
 - d. Tighten idler adjustment nut.
6. Check brake.
When the clutch bail is disengaged, the brake must contact attachment belt.
When the clutch bail is engaged, the brake must be more than 1/16 in (1.6 mm) away from the belt.
7. Repeat steps 4 – 6 until:
Spring stretch and brake contact are correct.

IMPORTANT: If attachment clutch/brake cannot be adjusted within tolerances, see your Dealer for repairs.

8. Check belt finger clearance.
With clutch bail engaged, belt fingers should be 1/16 – 1/8 in (1.6–3 mm) from belt. Adjust belt fingers as necessary.
9. Replace belt cover.
10. Check that auger/impeller stops within 3 seconds after attachment clutch/impeller brake bail is released.

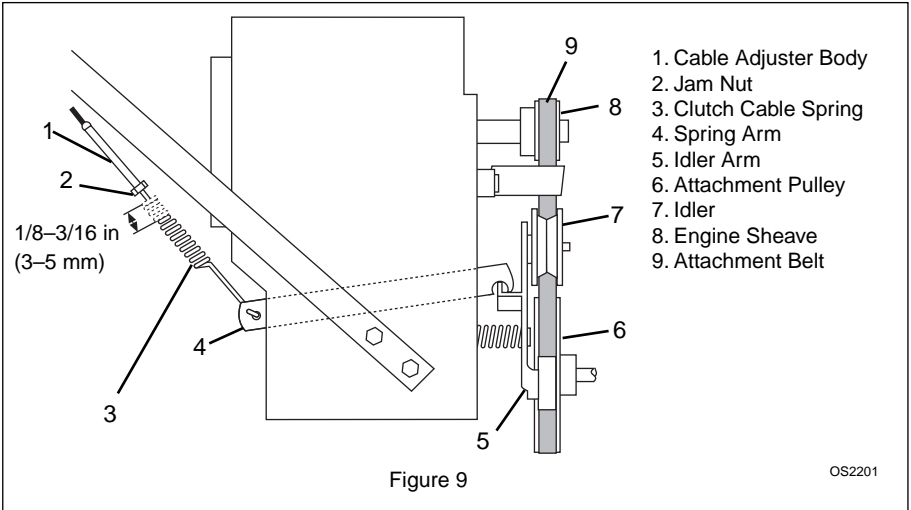

DISCHARGE CHUTE

If Chute does not stay in position while operating, tighten nut on carriage bolt at pivot point to increase tension on spring (Figure 10).

If the deflector cap does not remain set in position tighten nut on right side of cap until proper drag is obtained.

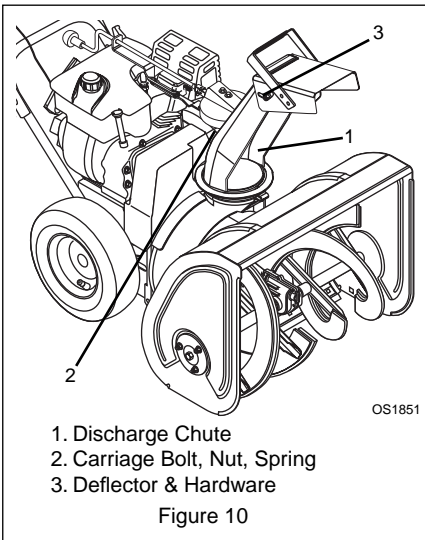

SHEAR BOLTS

IMPORTANT: Use only Ariens shear bolts for replacement. Use of any other type of shear bolt may result in severe damage to unit.

Occasionally a foreign object may enter the auger/impeller housing and jam the auger, breaking shear bolts (Figure 11) which secure the auger to the shaft. This allows auger to turn freely on the shaft preventing damage to gear drive.

For Replacement:

1. Slide auger outward and align hole in shaft with hole in auger.
2. Drive shear bolt through hole (if shear bolt was broken this will drive remaining part from shaft).
3. Secure shear bolt with nut.

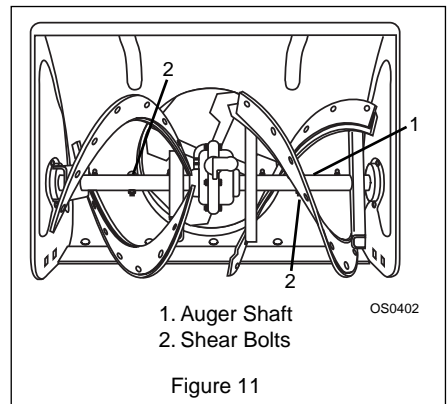

AUGER EDGE REPLACEMENT

Over time the rubber edges of the auger will wear. Contact your Ariens Dealer for replacement.

IMPORTANT: Replace rubber edges before metal auger begins to wear.

NOTE: After replacement of auger rubber edges, adjust scraper blade. See *Scraper Blade Adjustment* below.

SCRAPER BLADE ADJUSTMENT

IMPORTANT: Damage to auger/impeller housing will result if blade wears down too far. Scraper blade is adjustable to compensate for wear.

To adjust scraper blade:

1. Tip unit back onto handlebar, support housing and loosen nuts retaining blade.
2. If unit does not scrape cleanly, move scraper blade forward. If unit does not drive forward and scraper blade drags, move scraper blade to the rear.

Tighten hardware and test unit. Repeat adjustment as required until proper operation is obtained.

STORAGE



WARNING: AVOID INJURY. Read and understand *Storage Safety Rules* in *Safety* section before proceeding.

SHORT TERM

IMPORTANT: NEVER spray unit with high pressure water or store unit outdoors.

Run with attachment clutch engaged a few minutes after each use to free unit of any loose or melting snow.

Inspect unit for visible signs of wear, breakage or damage.

Keep all nuts, bolts and screws properly tightened and know unit is in safe working condition.

Store unit in a cool, dry protected area.

LONG TERM

Clean unit thoroughly with mild soap and low pressure water and lubricate (see *Maintenance*). Touch up all scratched painted surfaces.

Remove weight from wheels by putting blocks under frame or axle.

When storing unit for extended periods of time, remove all fuel from tank and carburetor (run dry). Refer to Engine Manual.

TROUBLESHOOTING

PROBLEM	PROBABLE CAUSE	CORRECTION
Engine will not crank/start.	<ol style="list-style-type: none">1. Fuel tank is empty.2. Build up of dirt and residue around governor/carburetor.3. Key Switch not in run position.4. Electric starter not functioning.5. Engine ignition problems.	<ol style="list-style-type: none">1. Fill fuel tank.2. Clean area around governor/carburetor.3. Put Key Switch into run position.4. Check for a bad starter or connections.5. See Engine Manual.

TROUBLESHOOTING

PROBLEM	PROBABLE CAUSE	CORRECTION
Engine stops.	<ol style="list-style-type: none"> 1. Out of fuel. 2. Mechanical jam in blower rake or impeller. 3. Polluted fuel supply. 4. Faulty spark plug. 	<ol style="list-style-type: none"> 1. Fill fuel tank. 2. Turn off engine, remove key, and wait for all moving parts to stop. Check for and remove obstruction and repair before restart. 3. Replace with clean fuel. 4. Replace or clean spark plug.
Engine problems.	See Engine Manual.	
Unit does not throw snow	<ol style="list-style-type: none"> 1. Shear bolts broken. 2. Attachment clutch/brake not adjusted properly. 3. Attachment drive belt worn or damaged. 	<ol style="list-style-type: none"> 1. Replace shear bolts (see <i>Shear Bolts</i>). 2. Adjust attachment clutch/brake (see <i>Attachment Clutch / Brake Adjustment</i>). 3. Replace attachment drive belt (see <i>Attachment Drive Belt Replacement</i>).

ACCESSORIES

See your authorized Ariens dealer to add the additional accessories available for your Sno-Thro.

Part No.	Description
73203100	Slicer Bar
72200600	120 Volt Starter Kit (932102)
73202500	240 Volt Starter Kit (932310)

SERVICE PARTS

Be sure to always use genuine Ariens parts to keep your Sno-Thro running like new.

Part No.	Description
53200500	Shear Bolt Replacement Kit
03243659	Scrapers Blade (932102)
03243259	Scrapers Blade (932103, 310)
07211400	Impeller Belt
21533400	Spark Plug (932102)
21533500	Spark Plug (932103, 310)

To obtain a complete parts manual, find your model and serial number. Then go to www.ariens.com or call 1-800-678-5443.

SPECIFICATIONS

Model Number	932102	932103	932310
Description	520	624	624
Engine - Tecumseh	HSSK50-67409T	OHSK60-71505D	OHSK60-71504D
Power Max - HP (Kw/min ⁻¹)	5 (3.73)	6 (4.47)	
Fast Idle Speed - RPM (min ⁻¹)	3600±150		
Displacement - in (cc)	11.88 (195)		
Electric Start	Optional 120V	120V	Optional 240V
Fuel	See Engine Manual		
Tank Capacity - qt (Liters)	2.0 (1.9)	3.5 (3.3)	
Snow Clearing Width - in (cm)	20 (50.8)	24 (61.0)	
Snow Throwing Distance - ft. (m)	3-35 (.9-10.6)		
Chute - Rotation Angle	220°		
Impeller Speed - Max RPM (min ⁻¹)	1240		
Auger			
Diameter - in (cm)	11 (27.9)		
Speed - Max RPM (min ⁻¹)	124		
Auger Clutch and Brake	Yes		
Tires - in (cm)	12 (30.5)		
Size and Weight			
Length - in (cm)	49 (124.5)		
Height - in (cm)	38 (96.5)		
Width - in (cm)	20.5 (52.1)	24.3 (61.7)	
Weight - lbs (Kg)	110 (49.9)	129 (58.5)	124 (56.2)
CE Sound and Vibration			
Oper. Ear Sound Pressure (L _{pa}) in dB _A	N/A		89
Vibration Measure @ Operator Hands m/sec ²			
X	N/A		2.4
Y	N/A		9.2
Z	N/A		2.9



Ariens Company
655 West Ryan Street
P.O. Box 157
Brillion, WI 54110-0157
920-756-2141
Fax 920-756-2407
www.ariens.com

3 Year Limited Sno-Thro Warranty

Ariens Company warrants to the original purchaser that consumer products manufactured by Ariens Company will be free from defects in material and workmanship for a period of three (3) years after the date of purchase, and will repair any defect in material or workmanship, and repair or replace any defective part, subject to the conditions, limitations and exclusions set forth herein.

The three year duration of this warranty applies only if the product is put to ordinary, reasonable, and usual personal, family, or household uses. If the product is put to any business, commercial, or industrial use, then the duration of this warranty is ninety (90) days after the date of purchase, or one (1) year after the date of purchase if the product is labeled as a Professional/Commercial Product. If any product is rented or leased, then the duration of this warranty is ninety (90) days after the date of purchase.

Genuine Ariens service parts and accessories not purchased with the product covered by this warranty, but which are later purchased and used with that product, are warranted to be free from defects in material and workmanship for a period of ninety (90) days after date of purchase, and Ariens Company will repair or replace any such part or accessory free of charge, except for labor, during that period.

This warranty is subject to the following conditions, limitations, and exclusions:

This warranty is valid only if the following conditions are met:

- The warranty registration card must be completed and returned to Ariens Company.
- The purchaser must perform maintenance and minor adjustments explained in the owner's manual.
- The purchaser must promptly notify Ariens Company or an authorized Ariens service representative of the need for warranty service.

The following items are not covered by this warranty:

- Engines and engine accessories are covered only by the warranty made by the engine manufacturer, and are not covered by this warranty.
- Parts that are not genuine Ariens service parts are not covered by this warranty.
- Shoes, runners, scraper blades, shear bolts, headlights, light bulbs, are not covered by this warranty.
- Any defect which is the result of misuse, alteration, improper assembly, improper adjustment, neglect, or accident, is not covered by this warranty.
- Products which were not purchased in the United States, Puerto Rico, or Canada are not covered by this warranty. In all other countries, contact place of purchase.

This warranty is subject to the following limitations:

- The purchaser must transport the product to and from the place of warranty service.
- Warranty service must be performed by an authorized Ariens service representative. (To find an authorized Ariens service representative, contact Ariens Company at the number or address above.)
- Batteries are warranted only for a period of twelve (12) months after date of purchase, on a prorated basis. For the first ninety (90) days of the warranty period, a defective battery will be replaced free of charge. If the applicable warranty period is more than 90 days, Ariens Company will cover the prorated cost of any defective battery, for up to twelve (12) months after the date of purchase.
- Normal maintenance items including, but not limited to, belts, idlers, cables, friction wheels, tires, wheels, electrical components are warranted for a two year period from the date of purchase unless a shorter period would apply based on how the product is used, then the shorter period will apply.

DISCLAIMER OF FURTHER WARRANTY

Ariens Company makes no warranty, express or implied, other than what is expressly made in this warranty. If the law of your state provides that an implied warranty of merchantability, or an implied warranty of fitness for particular purpose, or any other implied warranty, applies to Ariens Company, then any such implied warranty is limited to the duration of this warranty. Some states do not allow limitations on how long an implied warranty lasts, so the above limitation may not apply to you.

LIMITATION OF REMEDY AND DAMAGES

Ariens Company's liability under this warranty, and under any implied warranty that may exist, is limited to repair of any defect in workmanship, and repair or replacement of any defective part. Ariens Company shall not be liable for incidental, special, or consequential damages (including lost profits). Some states do not allow the exclusion of incidental or consequential damages, so the above limitation or exclusion may not apply to you.

This warranty gives you specific legal rights, and you may also have other rights which vary from state to state.

Form: ALW3-042301



Ariens Company
655 West Ryan Street
P.O. Box 157
Brillion, WI 54110-0157
920-756-2141
Fax 920-756-2407

DURA-CLEAN™ Auger Limited Lifetime Warranty

Ariens Company hereby warrants to the original purchaser that the rubber components of the DURA-CLEAN™ Auger manufactured by Ariens Company will be free from defects in material and workmanship and will not wear out for the life of the sno-thro, except as noted below.

Protection Plan

Ariens Company will provide for the replacement of any of the rubber components of the DURA-CLEAN™ Auger found upon examination by the Ariens Company to be defective or worn out. Replacements will be supplied free of charge. Labor is not included after two (2) years from the date of purchase of the sno-thro.

This warranty is subject to the following exceptions, conditions, and limitations:

Usage Requirement

The lifetime limited warranty shall apply if the product is put to ordinary, reasonable, and usual personal household use. If the product is put to any business, commercial, industrial, rental, or leased use, the warranty shall be against defects in material and workmanship for ninety (90) days following the date of purchase.

Exclusions (No Warranty)

There will be no warranty coverage if the product has been altered, misused, mis-assembled, improperly adjusted, neglected, damaged by accident, or if service is completed by someone other than an authorized Ariens dealer.

This warranty applies only to products purchased in the United States (including Puerto Rico) and Canada. In all other countries, contact place of purchase.

Ariens Company may from time to time change the design of its products. Nothing contained in this warranty shall be construed as obligating Ariens Company to incorporate such design changes into previously manufactured products, nor shall such changes be construed as an admission that previous designs were defective.

LIMITATION OF REMEDY AND DAMAGES

Ariens Company's liability under this express warranty, and under any implied warranty that may exist, is limited to repair or replacement of any defective part. In no event shall Ariens Company be liable for incidental, special, or consequential damages (including lost profits). This warranty gives you specific legal rights. You may also have other rights which vary from state to state. Some states do not allow the exclusion of incidental or consequential damages, or limitations on how long an implied warranty lasts, so the above limitations and exclusions may not apply to you.

DISCLAIMER OF FURTHER WARRANTY

Ariens Company makes no warranty other than what is expressly made in this warranty. If the law of your state provides that an implied warranty of merchantability, or an implied warranty of fitness for a particular purpose, applies to Ariens Company, any such implied warranty is limited to the duration of this express warranty.

Form: DC-042400



Ariens Company
655 West Ryan Street
P.O. Box 157
Brillion, WI 54110-0157
920-756-2141
Fax 920-756-2407
www.ariens.com