

▲ SAFETY MESSAGE ▲

The product for which you have requested information or replacement parts is not a current product. The replacement models incorporate product designs, safety features, safety instructions or warnings which represent the latest "State Of The Art" developments. For your safety and those around you please contact your nearest Ariens/Gravely Dealer for a demonstration of the current product safety provisions and features.

Ariens®

Sno-Thro®

Owner/Operator Manual

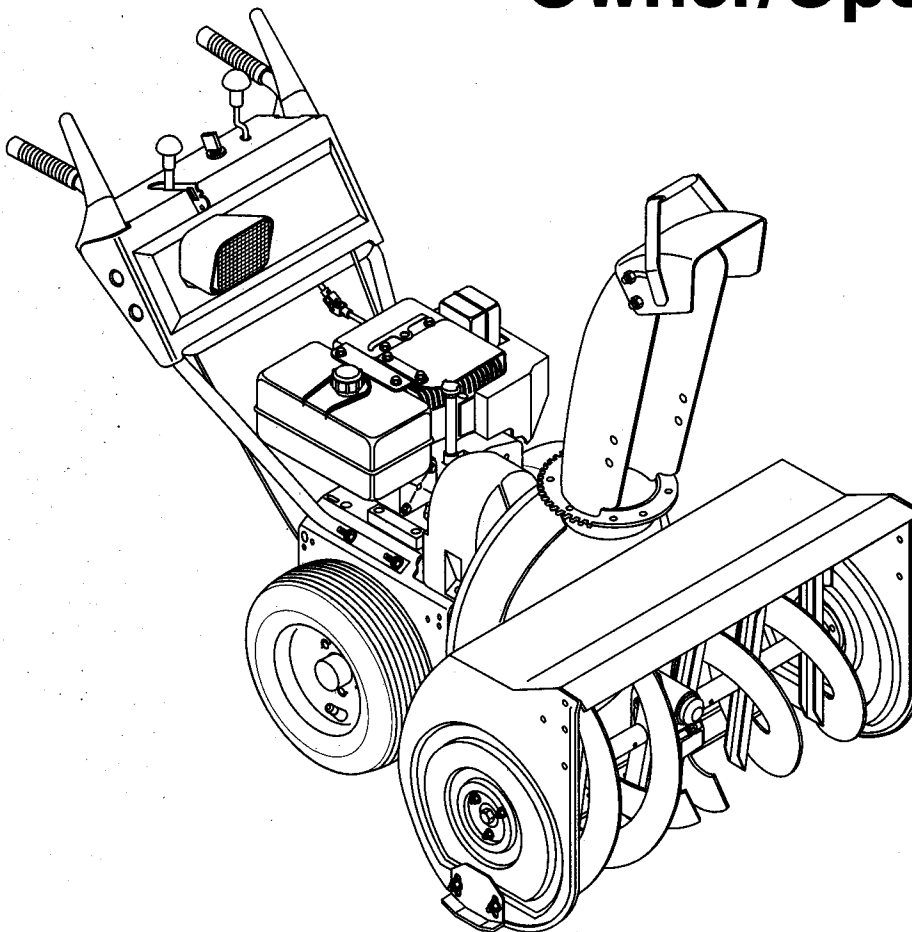

924
SERIES

MODELS

- 100 - ST824
- 101 - ST928
- 102 - ST1032
- 103 - ST1236
- 104 - ST1028
- 105 - STT8
- 106 - ST1024

02472600 Orig. 9/97
Supersedes 02471400
Printed in USA

Ariens®

Thank You

Ariens outdoor power equipment is engineered to be the best from start to finish. We have one fundamental belief: *Value is not measured solely by price; value is a durable, easy-to-use machine that performs season after season.*

This manual and the engine manual are your guides. By following the instructions and procedures in them, your Ariens equipment will serve you well for many years. The care you give this unit will determine your overall satisfaction and its service life.

Safety is up to you. Obey all correct operating practices and procedures for this unit. Prevent serious injury or death.

Three reasons safety is important:

1. Accidents can disable and kill.
2. Accidents can be avoided.
3. Accidents always cost.

Ariens proudly offers one of the finest warranties in the business. Contact your Ariens Dealer with any questions, comments or orders. Ariens equipment for the world is made in the USA.



**Crafted in
America
Since 1933**

YOUR SATISFACTION IS IMPORTANT

Questions? Please follow these helpful steps:

1. Always Refer to Your Owner/Operator or Engine Manual First.

- a) Its detail will guide you through safe and proper operation and maintenance.
- b) It contains specifications on your model.
- c) If your questions are not answered in these manuals, go to step number two.

2. Contact Your Ariens Dealer.

- a) Our dealers will be happy to supply any service or advice required to keep your unit operating at peak efficiency.
- b) A factory trained staff is available to support your equipment needs. They stock genuine Ariens parts and lubricants manufactured with the same precision and skill as the original.
- c) If your questions are not resolved by the support staff, ask for the manager or owner.
- d) When contacting your Ariens Dealer supply your model and serial numbers.

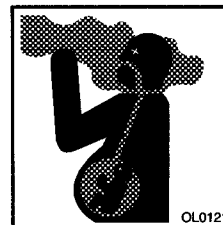

WARNING

The engine exhaust from this product contains chemicals known to the State of California to cause cancer, birth defects or other reproductive harm.

A TABLE OF CONTENTS

SNO-THRO MODELS

Model Number 924100
ST824, 8 HP 24"

Model Number 924101
ST928, 9 HP 28"

Model Number 924102
ST1032, 10 HP 32"

Model Number 924103
ST1236, 12 HP 36"

Model Number 924104
ST1028, 10 HP 28"

Model Number 924105
STT8, 8 HP Tractor

Model Number 924106
ST1024, 10 HP 24"

SECTION 1: INTRODUCTION

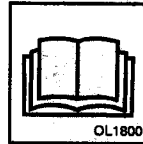

The Manual	1
Service and Replacement Parts	1
Product Registration	1
Disclaimer	1

SECTION 2: SAFETY



Safety Alert Symbol	2
Signal Words	2
Practices and Laws	2
Required Operator Training	2
Safety Decals and Locations	3
Unit, Operational, Personal, Service and Maintenance Safety Rules	4

SECTION 3: OPERATION



Controls and Features	8
Pre-Start	11
Starting and Shut Off	12
Throwing Snow	13
Traveling	13
Transport	14

SECTION 4: GENERAL MAINTENANCE



Service Position	14
Filling Fuel Tank	14
Fuel Shut-Off Valve	15
Engine	15
Drive Belts	15
Shear Bolts	17
Tire Pressure	17
Friction Wheel	17
Auger Gearcase	17
Lubrication Locations	18
Adjustments	18
Cleaning and Storage	20
Service Manual	21
Maintenance Schedule	21
Trouble Shooting	21
Attachments and Accessories	21
Specifications	23
Warranty	Inside Back Cover

A SECTION 1: INTRODUCTION

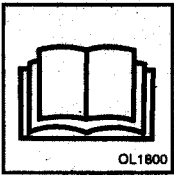

THE MANUAL

Before operation of unit, carefully and completely read your manuals. The contents will provide you with an understanding of safety instructions and

controls during normal operation and maintenance.

All reference to left, right, front, or rear are given from operator standing in operation position and facing the direction of forward travel.



SERVICE AND REPLACEMENT PARTS

When ordering replacement parts or making service inquiries, know the Model and Serial numbers of your unit and engine.

Numbers are located on the product registration form in the unit literature package. They are printed on a serial number label, located on the frame of your unit (Figure 1).

- Record Unit Model and Serial numbers here.

- Record Engine Model and Serial numbers here.

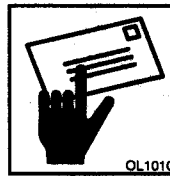
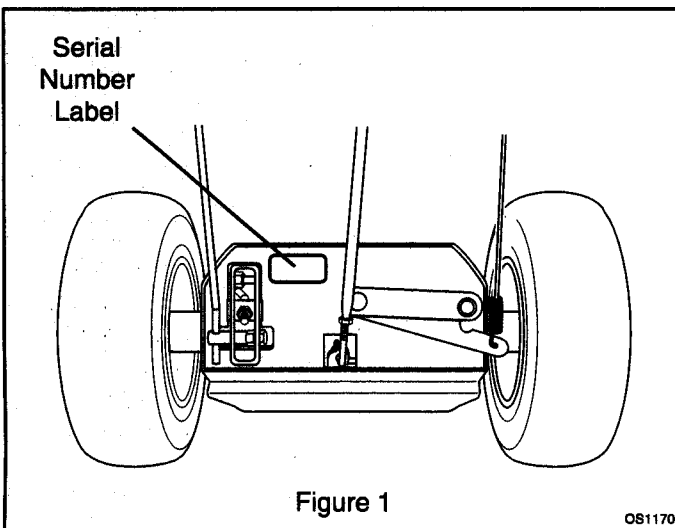

PRODUCT REGISTRATION

A warranty registration card must be filled out by the Ariens dealer, signed, and returned at time of sale. This form activates the warranty.

The replacement of any part on this vehicle with anything other than an Ariens authorized replacement part may adversely affect the performance, durability, or safety of this unit and may void the warranty. Claims meeting requirements during limited warranty period will be honored.

To guarantee full warranty service, make sure your registration card has been returned to Ariens Company.

DISCLAIMER

Ariens Company is hereinafter referred to as Ariens. Ariens reserves the right to discontinue, make changes to, and add improvements upon its products at any time without public notice or obligation. Ariens disclaims liability for any claims or damages, whether regarding property, personal injury or death arising out of the use of unauthorized replacement parts. The descriptions and specifications contained in this manual were in effect at printing. Equipment described within this manual may not be identified as either standard or optional. Illustrations may not be applicable to your unit.

Customer Note: Your Ariens Dealer has been provided complete setup and preparation instructions which must be completed prior to you taking delivery of this unit. The dealer is required to review important information in this manual with you before or upon delivery of the unit or attachment.

A SECTION 2: SAFETY



SAFETY ALERT SYMBOL

This is a safety alert symbol. It means:

- **ATTENTION!**
- **YOUR SAFETY IS INVOLVED!**

When you see this symbol:

- **BECOME ALERT!**
- **OBEY ITS MESSAGE!**

SIGNAL WORDS

The safety alert symbol is used with the signal words **▲ DANGER**, **▲ WARNING** and **▲ CAUTION** and colors to alert you to safety messages.

They are used in safety decals on the unit and with proper operation and procedures in this manual. They alert you to the existence and relative degree of hazards.

Understand the safety message. It contains important information about personal safety on or near the unit.

▲ DANGER

IMMINENTLY HAZARDOUS SITUATION! If not avoided, **WILL RESULT** in death or serious injury.

▲ WARNING

POTENTIALLY HAZARDOUS SITUATION! If not avoided, **COULD RESULT** in death or serious injury.

▲ CAUTION



POTENTIALLY HAZARDOUS SITUATION! If not avoided, **MAY RESULT** in minor or moderate injury. It may also be used to alert against unsafe practices.

Notations

NOTE: General reference information for proper operation and maintenance practices.

IMPORTANT: Specific procedures or information required to prevent damage to unit or attachment.

▲ WARNING



IMPROPER OPERATION of this unit can result in death or serious injury. Before starting engine, follow these three steps:

1. Read and understand this manual and all safety decals on unit or attachment.
2. Clear area of children and people.
3. Clear area of objects that may be thrown.

PRACTICES AND LAWS

Practice usual and customary safe working precautions, for the benefit of yourself and others. Understand and follow all safety messages. Be alert to unsafe conditions and the possibility of minor, moderate, or serious injury or death. Learn applicable rules and laws in your area.

REQUIRED OPERATOR TRAINING

Original purchaser of this unit was instructed by the seller on safe and proper operation. If unit is to be used by someone other than original purchaser; loaned, rented or sold, **ALWAYS** provide this manual and any needed safety training before operation.

SAFETY DECALS AND LOCATIONS

ALWAYS replace missing or damaged Safety Decals. Refer to Figure 2 for Safety Decal locations.

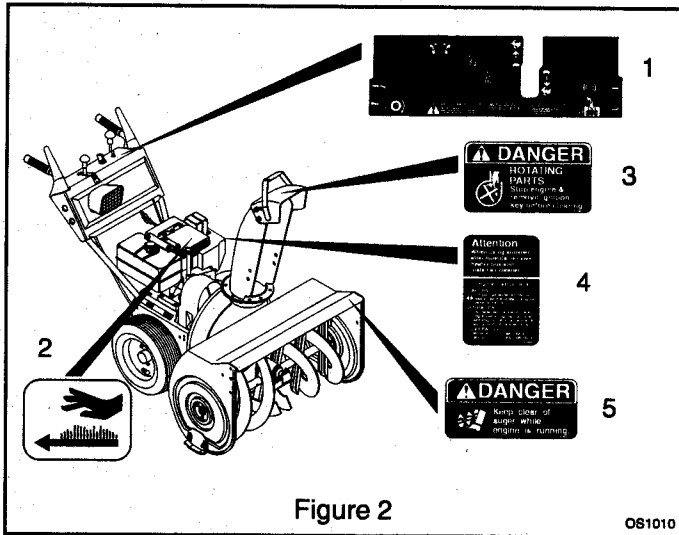

4. ATTENTION

When using summer attachments remove heater box and install air cleaner.

Engine Instructions

CAUTION! For your personal protection, read all safety notes in engine owner's manual.

OPERATION: For detailed lubrication, starting, and operating instructions, see engine owner's manual and equipment manufacturer's instruction.

LUBRICATION:

Summer SAE 30 Oil
Winter SAE 5W-30 Oil



5. DANGER!

Keep clear of auger while engine is running.

1. SAFETY INSTRUCTIONS

To avoid possible injury, read owner's manual and understand purpose of all safety alerts.

- Allow operation only by properly trained adult, never children.
- Stop engine and remove ignition key prior to leaving operator's position for any reason.
- Keep all controls, guards and safety devices properly serviced and functional.
- Never direct discharge towards persons or property that may be damaged by thrown objects.



2. HOT SURFACES!

DO NOT touch parts which are hot from operation. ALWAYS allow parts to cool.



3. DANGER Rotating Parts!

Stop engine and remove key before clearing.

UNIT SAFETY



Walk Around Inspection

Complete a walk around inspection of unit and work area to understand:

- Work area
- Your unit
- All safety decals

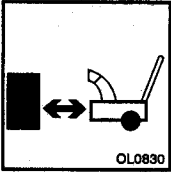

Clearances

ALWAYS check overhead and side clearances carefully before operation.

ALWAYS be aware of traffic when operating along streets or curbs.

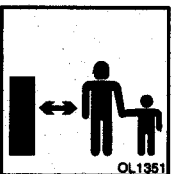

Work Area

Keep children and people away.

Keep children out of work area and under watchful care of a responsible adult.



Clear Work Area

Keep area of operation clear of all toys, pets, and debris. Thrown objects can cause injury.



Avoid Falls

Check for weak spots on dock, ramps or floors. Avoid uneven work areas and rough terrain. Stay alert for hidden hazards.



Slippery Surfaces

Avoid slippery surfaces. ALWAYS be sure of your footing, especially when operating in reverse.

DO NOT operate at high transport speeds on slippery surfaces. Never run during operation.



Visual Obstruction

Dust, smoke, fog, etc. can reduce vision and cause an accident. Operate unit only when there is good visibility and light.



Safety Guards and Devices

ALWAYS keep protective structures, guards, and panels in good repair, in place and securely fastened.

NEVER modify or remove safety devices.



Clutches and Brakes

Check clutch and brake operation frequently. Adjust and service as required.

OPERATIONAL SAFETY

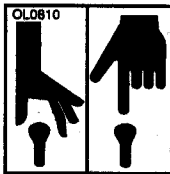

Rules of Operation

Understand:

- How to operate all controls
- The functions of all controls
- How to STOP in an Emergency



Child Safety

NEVER allow children to operate, play on or near unit.

Be alert and shut off unit if children enter area.

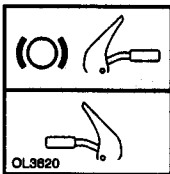

Pre-Start

Before starting engine: disengage all clutches, adjust runners to clear surface safely.



Speed Ranges

DO NOT operate at too fast a rate. DO NOT change engine governor settings or over speed engine. Slow down and turn corners slowly.

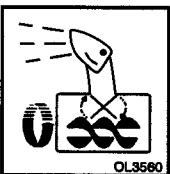

Attachment Power

Disengage attachment when not in use. ALWAYS turn off power to attachment when traveling across previously cleared areas, etc.



Ambient Temperature

ALWAYS allow unit and engine to adjust to outdoor temperatures before clearing snow.



No Riders

Never carry passengers.



Reverse

DO NOT operate in reverse unless absolutely necessary. ALWAYS backup slowly. ALWAYS look down and behind, before and while backing.



Avoid Tip over

Avoid uneven and rough terrain. DO NOT operate near drop offs, ditches, or embankments. Unit can suddenly turn over if a wheel is over the edge of a cliff or ditch, or if an edge caves in.



Hazardous Slopes

DO NOT operate on steep slopes. DO NOT clear snow across the face of slopes.

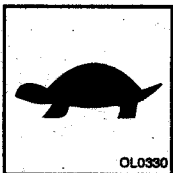

Keep all movement on slopes slow and gradual. DO NOT make sudden changes in speed or direction. Use a slow speed to avoid stops or shifts on slopes. Avoid starting or stopping on a slope.

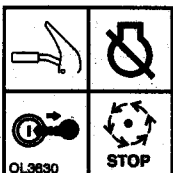

Shutoff

ALWAYS disengage attachment, stop unit and engine, remove key and allow moving parts to stop before leaving operator's position.

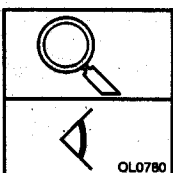

Abnormal Vibrations, Foreign Objects, Clogged Unit

Immediately shut off unit as above. Check for any damage or loose parts and repair before restart.



Parking

Run unit a few minutes after throwing snow to prevent freeze-up of impeller.

Never leave a running unit unattended. ALWAYS shut off engine before leaving unit.

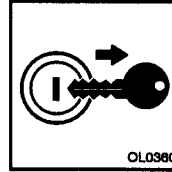

ALWAYS remove key to prevent unauthorized use.



Unit Roll-Away

DO NOT park unit on a slope unless absolutely necessary. When parking on a slope always cock or block the wheels.

PERSONAL SAFETY



Responsible Operators

- Only trained adults may operate unit
- Training includes actual operation



No Drugs

NEVER operate unit after or during the use of medication, drugs or alcohol. Safe operation requires your complete and unimpaired attention at all times.



No Alcohol

NEVER allow anyone to operate this unit when their alertness or coordination is impaired.

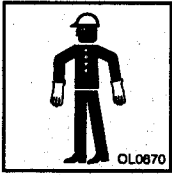

Safety Gear

DO NOT operate unit without wearing adequate winter outer garments. Wear adequate safety gear, protective gloves. Wear proper footwear to improve footing on slippery surfaces.

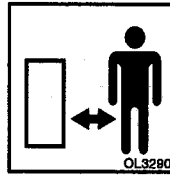

Safe Distances

Keep children and people away from unit during operation.

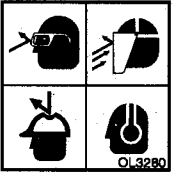

Protect eyes, face and head from objects that may be thrown from unit. Wear appropriate hearing protection.



Avoid Thrown Objects

Deflected materials can cause injury and property damage. DO NOT point discharge at anyone or discharge directly onto paved or gravel surfaces. Use extreme caution on gravel surfaces. Adjust Runners so Scraper Blade does not contact gravel.

Always stand clear of the discharge area when operating this unit.



Avoid Sharp Edges

Sharp edges can cut. Movement of parts can cut off fingers or a hand.



Avoid Exhaust Fumes

Fumes from engine exhaust can cause injury or death.



Avoid Rotating Parts

ALWAYS keep hands and feet away from all rotating parts during operation. Rotating parts can cut off body parts.

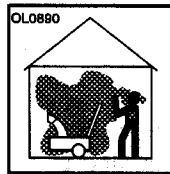

Ventilation

DO NOT run engine in an enclosed area. Always provide good ventilation and wait until hazard has been removed.

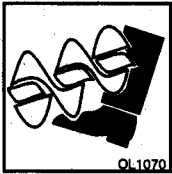

Avoid Pinch Points

ALWAYS keep hands away from all pinch points.



Avoid Hot Surfaces

DO NOT touch unit parts which might be hot from operation. Allow parts to cool before attempting to maintain, adjust or service.

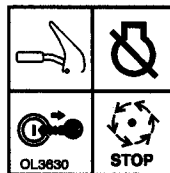

Prepare Unit

Before cleaning or making any inspections, repairs, etc.: disengage clutches, stop unit and engine, remove key, allow moving parts to stop. Disconnect spark plug wire and keep wire away from plug to prevent accidental start-up.

Allow hot parts to cool.



Avoid Entanglement

NEVER place your hands or any part of your body or clothing inside or near any moving part while unit is running.



Service Position

Before tipping unit up onto housing, remove enough fuel so no spillage will occur. Assure unit is secure and will not tip over during maintenance.



DO NOT wear loose clothing or jewelry and tie back hair that may get caught in rotating parts.





Explosive Fuel

Fuel is highly flammable and its vapors are explosive. Handle with care. Use an approved fuel container.



NO smoking, NO sparks, NO flames. ALWAYS allow engine to cool before servicing.

NEVER fill fuel tank when engine is running or hot from operation.

NEVER fill or drain fuel tank indoors.

Replace fuel cap securely and clean up spilled fuel.



Replacement Parts

ALWAYS maintain unit in safe operating condition. Damaged or worn out muffler can cause fire or explosion.



Hardware

Keep hardware tight.



Cleaning

Keep unit free of ice or other debris. Clean up oil or fuel spills.



Storage

For unit storage or extended storage:

- NEVER store with fuel in fuel tank, inside a building where any ignition sources are present
- Allow engine to cool completely
- For extended storage, clean unit thoroughly. See Engine Manual for proper storage.

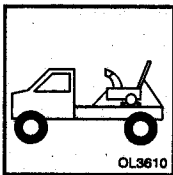

Transport

Use extra care when loading or unloading unit onto trailer or truck.

Secure unit chassis to transport vehicle. NEVER secure from rods or linkages that could be damaged.

DO NOT transport machine while engine is running.

Close Fuel Shut Off Valve before transport to prevent fuel leakage.

ATTACHMENTS AND ACCESSORIES

Use only attachments or accessories designed for your unit.

Check attachment components frequently. If worn or damaged, replace with manufacturer's recommended parts.



A SECTION 3: OPERATION

CONTROLS AND FEATURES

See Figure 3 for all Controls and Features locations.

Dual Handle Interlock

When Attachment Clutch and then Traction Drive Clutch are engaged, the Attachment Clutch will remain engaged (lever down) if released. To stop attachment, release Traction Drive Clutch and both clutches will disengage.

Traction Drive Clutch - Left Hand Lever

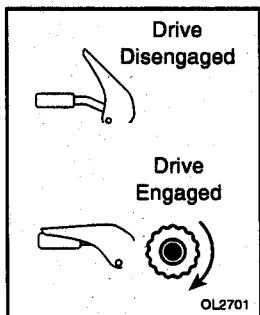

Squeeze the Traction Drive Clutch Lever against the Handlebar to engage wheel drive for propelling unit. Forward speed will vary according to snow depth and moisture content.

Release lever to stop movement.

NOTE: When traveling to or from area to be cleared, press down on handlebars enough to raise front of unit slightly off surface and engage Traction Drive Clutch without engaging Attachment Drive Clutch.

NOTE: Attachment Clutch should be engaged before Traction Drive Clutch when throwing snow.

Attachment Clutch - Right Hand Lever

WARNING

THROWN OBJECTS could result in personal injury and/or property damage. **ALWAYS** discharge in a safe direction. Disengage attachment power when unit is being transported to work area or is not in use. Use extreme caution when operating on or crossing gravel surfaces.

CAUTION

STRIKING FOREIGN OBJECTS may damage unit and result in minor or moderate injury. Shut off unit and engine and remove wire from spark plug. Check for any damage or loose parts and repair before restart.

IMPORTANT: Check impeller to be sure it is not frozen. If belt squeals when the Attachment Clutch Lever is engaged, the Impeller is frozen. Immediately release the Attachment Clutch Lever and move the unit to a heated area to thaw.

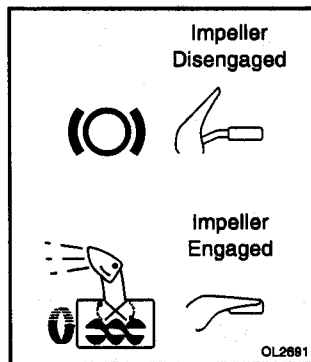

Release both clutch levers to disengage power and apply brake to attachment.

Squeeze Attachment Clutch Lever against Handlebar to engage attachment.

Ignition Switch

WARNING

ACCIDENTAL ENGINE START UP or UNAUTHORIZED USE could result in death or serious injury. **ALWAYS** shut off unit and remove key before servicing or leaving unit unattended.

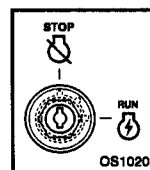

The Ignition Switch is operated by a removable Key. It has two positions:

1. "Stop"
2. "Run"

Primer Bulb

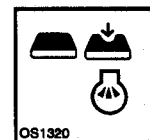

Pushing the Primer Bulb in adds fuel for easier engine start (see Starting and Shut Off).

Choke Control Knob

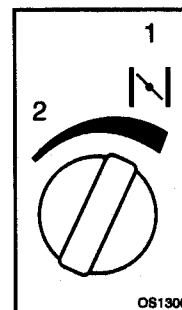

1. "Choke Closed" position: Choke Control chokes off air to engine for easier start.
2. "Choke Open" position: allows for normal operation.

IMPORTANT: After engine starts, adjust choke as needed.

CONTROLS AND FEATURES LOCATIONS

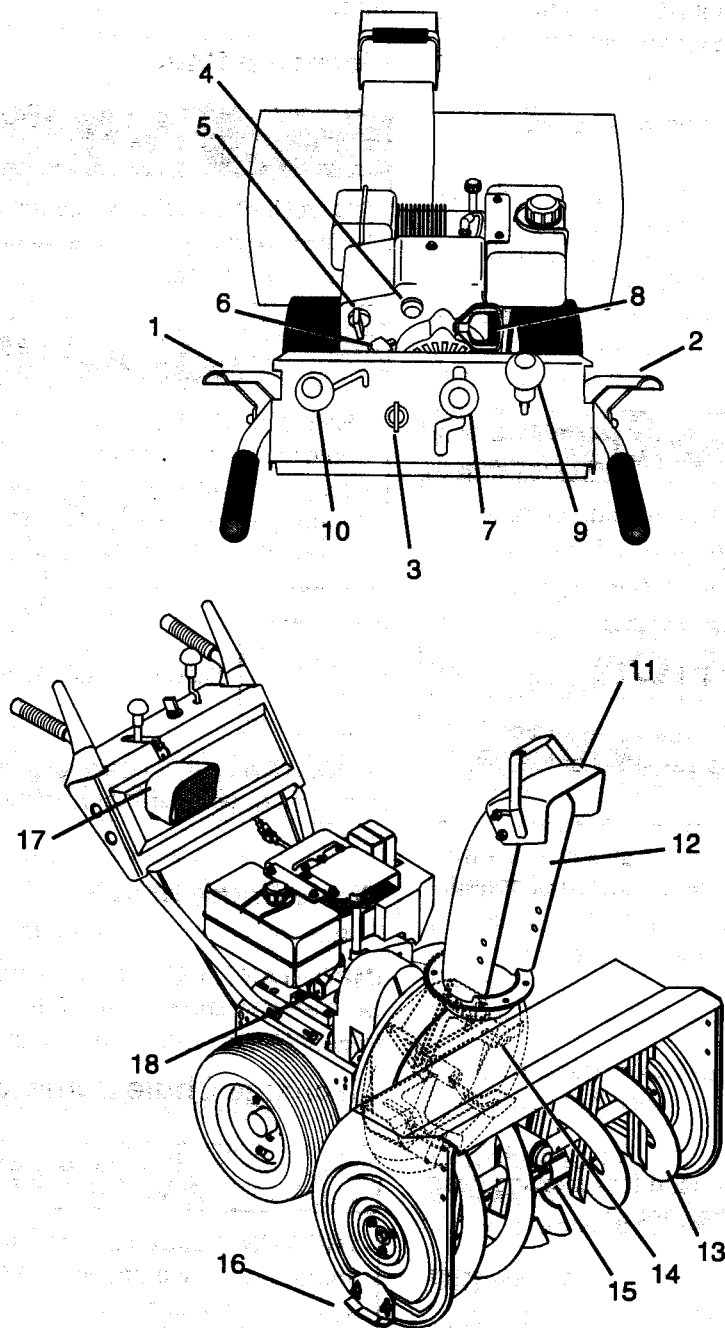

- | | |
|--------------------------------|-------------------------------|
| 1. Traction Drive Clutch Lever | 10. Chute Crank |
| 2. Attachment Clutch Lever | 11. Discharge Chute Deflector |
| 3. Ignition Switch and Key | 12. Discharge Chute |
| 4. Primer Bulb | 13. Auger |
| 5. Choke | 14. Impeller |
| 6. Throttle | 15. Scraper Blade |
| 7. Speed Selector | 16. Runner(s) |
| 8. Recoil Starter Handle | 17. Headlight |
| 9. Deflector Remote Control | 18. Fuel Shut Off Valve |

OS0580

Figure 3

OS1130

Throttle

The Throttle controls the engine speed. To increase or decrease the engine speed position control by adjusting to:

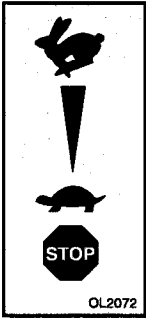

1. "Fast" (normal or warm starts)
2. "Part-Throttle" (cold weather starts)
3. "Slow"
4. "Stop" (engine is off)

OL2072

Speed Selector

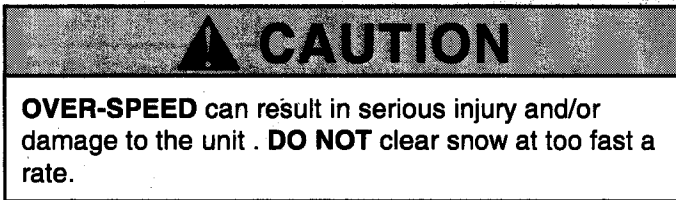
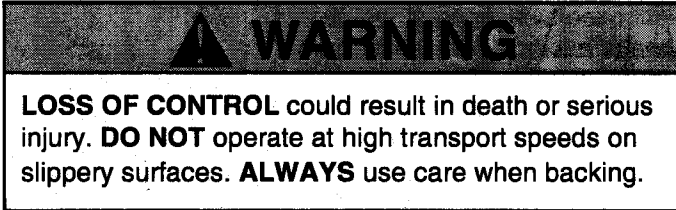

The Speed Selector controls the unit travel in a forward or reverse direction when positioned in notch of speed.

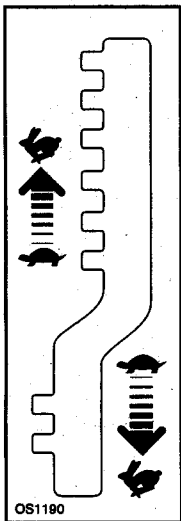

Forward:

- (6) "Fast"
- (5)
- (4)
- (3)
- (2)
- (1) "Slow" (Best used for removing deep or hard packed snow)

Reverse:

- (1) "Slow"
- (2) "Fast"

OS1180

IMPORTANT: Forward speed can be changed without de-clutching. **DO NOT** change motion from forward to reverse with clutch engaged.

Recoil Starter Handle

When pulled, handle will turn engine over.

IMPORTANT: **DO NOT** let handle snap back against starter.

Discharge Chute

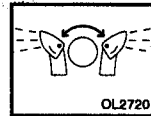
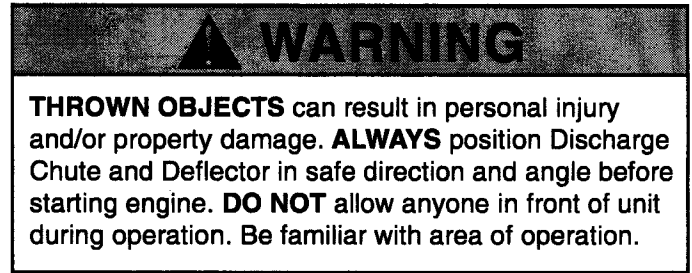
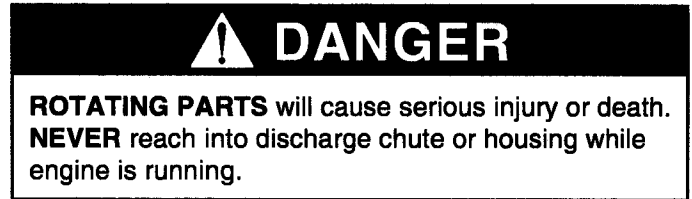

Discharge Chute rotates 230°.

OL2720

IMPORTANT: If Chute does not stay in set position, adjust as directed in Adjustment Section, or repair before operation.

Chute Crank Handle

Rotate the Chute with Discharge Chute Crank Handle.

IMPORTANT: **DO NOT** force frozen Chute controls. Start engine and run for 3-5 minutes to thaw. If still frozen, take to warm place until controls are free.

Discharge Chute Deflector

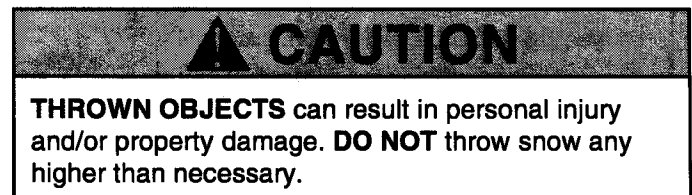

IMPORTANT: If Chute Deflector does not stay in set position, adjust as directed in Adjustment Section, or repair before operation.

Deflector Remote Control (Optional)

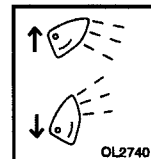

OL2740

For operation push Deflector Remote Control knob forward to adjust Deflector downward. To adjust Deflector upward push Deflector Remote Control knob downward.

Differential Lock Knob

Differential Lock Knob is located on the left wheel hub. With differential locked, power is applied equally to both wheels.

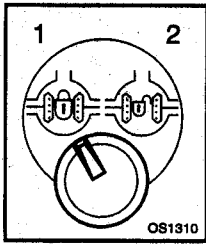

To engage differential lock:

- Pull and turn knob to "Locked" (1) position and release (knob will snap in place when positioned correctly).

To resume differential action for transport:

- Pull and turn knob to "Unlocked" (2) position and release.

Scraper Blade

IMPORTANT: DO NOT allow Scraper Blade to wear or Auger / Impeller housing will become damaged.

Runners

For operation on gravel surface, lower Runners so that housing will not pick up gravel. On concrete, blacktop or packed snow surfaces raise Runners so that Scraper Blade scrapes clean. To reduce tendency of housing to ride up over heavy wet or hard-packed snow, remove Runners and reinstall with their narrow edge down.

Headlight (Optional)

CAUTION

VISUAL OBSTRUCTION can reduce visibility and cause an accident. Operate unit only when there is good visibility and light.

The headlight operates only when the engine is running. Adjust the headlight: loosen the hardware, position light and retighten hardware.

NOTE: Lamp remains "On" at all times for longer lamp life. Lamp is more sensitive to fatigue failure when unlit than when lit.

PRE-START

WARNING

IMPROPER CLOTHING AND SAFETY GEAR could result in death or serious injury. Wear adequate winter gear, protective gloves and footwear which will improve footing on slippery surfaces. **DO NOT** wear loose clothing or jewelry and tie back hair that may get caught in rotating parts.

THROWN OBJECTS could result in death or serious injury. Wear safety goggles to protect eyes.

CAUTION

IMPROPER MAINTENANCE may result in minor or moderate injury. Make sure all hardware is tight, all safety devices are in place and all adjustments correct. Check function of all controls before starting engine.

NOTE: This product is equipped with an internal combustion type engine. **DO NOT** use unit on or near any unimproved, forest-covered or brush covered land unless exhaust system is equipped with a spark arrester meeting applicable local, state or federal laws. A spark arrester, if it is used, must be maintained in effective working order by operator.

Frozen Impeller

IMPORTANT: Before engine start check Impeller to be sure it is not frozen. With key in "Stop" position, squeeze Attachment Clutch Lever to Engaged position and pull Recoil Starter Handle. If Impeller is frozen, (cannot pull Starter Handle) move unit to a heated area and thaw to prevent possible damage.

Engine Fuel

WARNING

FLAMMABLE FUEL and its **EXPLOSIVE VAPORS** can result in death or serious injury. Handle fuel with extreme care. **ALWAYS** use an approved fuel container. **NO Smoking! NO Lighted Materials! NO Open Flames!** Allow engine to cool before any service.

Check and add fuel if required. Refer to General Maintenance Section.

Crankcase Oil

Check that the engine crankcase oil is full using dipstick. Refer to General Maintenance Section.

Differential Lock

ALWAYS engage differential lock (located in left wheel hub) for best traction when throwing snow.

Runners

CAUTION

THROWN OBJECTS can result in personal injury and/or property damage. On gravel surface, lower runners so that housing will not pick up gravel.

Check and adjust Runners (see Adjustments). Allow 1/8" (3mm) between scraper blade and hard, smooth surface(s). Allow 1-1/4" (30mm) between scraper blade and uneven surface(s).

Function of Clutches

WARNING

FAILURE OF CLUTCHES OR BRAKES may result in death or serious injury. Check clutch and brake function before each use. Repair or adjust before operation.

If the Impeller does not stop quickly when the Attachment Clutch Lever is released or there is no noticeable increase in the Lever force before contacting the Handlebar, adjust as directed in the Adjustments Section, or repair before operation.

Function of Dual Handle Interlock

Check by pressing down on Clutch Levers (engaging both clutches). Remove hand from Attachment Clutch Lever, attachment clutch lever should remain engaged until Traction Clutch Lever is released then both clutches must disengage.

STARTING AND SHUT OFF

WARNING

FAILURE TO FOLLOW INSTRUCTIONS could result in personal injury and/or damage to unit. **DO NOT** attempt to start your unit at this time. Read entire Owner/Operator Manual and the Engine Manual first.

IMPORTANT: At start up, allow unit and engine to adjust to the outdoor temperatures before clearing snow. Before shut off, run impeller a few minutes to prevent freeze-up of impeller.

NOTE: Try out each control without the engine running to see how they work and what they do.

Manual Start

See Figure 3 for all Controls and Features locations.

WARNING

THROWN OBJECTS could result in death or serious injury. **ALWAYS** position Discharge Chute straight ahead (away from operator) for starting.

1. Turn discharge chute straight ahead.
2. Push Primer Bulb 2 or 3 times for cold engine.

NOTE: When temperature is below -15° F (-26° C) additional priming may be needed.

3. If engine is cold, apply choke. See Engine Manual for detailed instructions.

NOTE: A warm engine requires less choking than a cold engine. If fuel drips out of carburetor during starting, engine is over-choked. Pull starter handle several times with choke open before continuing.

4. Set Throttle to proper starting position.
5. Insert key into Ignition Switch.
6. Turn key to "Run" position.
7. Stand to right of unit. Grasp starter handle and pull rope out slowly until it pulls harder, this is compression stroke, let rope rewind slowly.
8. Pull rope with a rapid continuous full arm stroke. Let rope rewind slowly.

IMPORTANT: DO NOT let Starter Handle snap against Starter.

9. Repeat until engine starts. (If engine does not start, refer to Engine Manual.)
10. After engine starts, adjust choke as needed.

WARNING

ABNORMAL VIBRATIONS are a warning of trouble. Immediately stop unit and engine, remove key, and allow all moving parts to stop. Remove wire from spark plug. Inspect unit and make any necessary repairs before restart.

11. Set throttle to "Part Throttle" or "Slow" position for adaptation to ambient temperature or travel to work area. Before throwing snow, set throttle to "Fast" position for normal operation.

Shut Off

WARNING

IMMEDIATELY RELEASE BOTH CONTROL LEVERS TO STOP UNIT in an emergency.



Stop Engine, remove Key and wait for all rotating parts to stop before leaving operators position.

OL0964 STOP

1. Release Traction Drive Clutch Lever and allow unit to come to a complete stop.
2. Engage and run Impeller a few minutes after use to prevent freeze-up of Impeller.
3. Release Attachment Clutch Lever and wait for all moving parts to come a complete stop.
4. Move Throttle to the "Slow" position.
5. Turn Ignition Switch to "Stop" position.
6. Remove key.

THROWING SNOW

CAUTION

HIDDEN HAZARDS may result in minor or moderate injury and/or damage to unit. Stay alert for holes, rocks, roots, traffic, and other hazards.

After proper Pre-Start and Starting:

1. Select Speed Control range and direction.

IMPORTANT: DO NOT overload unit capacity by attempting to clear snow at too fast a rate.

2. Engage Attachment Clutch - Right Hand Lever.
3. Engage Traction Drive Clutch - Left Hand Lever.

Snow Throwing Tips

Snow is best removed as soon as possible after a snow fall.

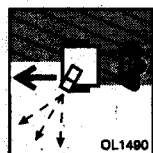

To clear an area, run unit in an overlapping series of paths. For large areas; start in the middle and throw snow to each side, so snow is not cleared more than once.

ALWAYS direct snow away from area to be cleared and with direction of the wind.

TRAVELING

To travel from one work area to another:

1. Set Throttle to "Slow" or "Part Throttle" position.
2. Press down on handlebars enough to raise front of unit slightly off surface.
3. Engage wheel drive clutch without engaging attachment drive clutch.

TRANSPORT

ALWAYS shut off engine, remove key, and close fuel shut off valve when transporting unit on a truck or trailer.

A SECTION 4: GENERAL MAINTENANCE

Ariens Dealers will provide any service or adjustments which may be required to keep your unit operating at peak efficiency. Should engine service be required, contact an Ariens dealer or an authorized engine manufacturer's service center.

WARNING

ACCIDENTAL ENGINE START UP can cause death or serious injury. **ALWAYS** stop engine, remove key, wait for moving parts to stop and remove wire from spark plug before adjusting or servicing.

HOT SURFACES can result in death or serious injury. **DO NOT** touch parts which are hot from operation. **ALWAYS** allow parts to cool.

SERVICE POSITION

Place unit on a flat level surface. Tip unit forward onto front of Impeller housing for service. Assure unit is secure and will not tip over. Strap and clamp onto bench if needed.

CAUTION

FUEL SPILLS may result in minor or moderate injury and/or damage to unit. Before unit is tipped up onto housing, remove enough fuel so that no spillage will occur.

FILLING FUEL TANK

WARNING

FLAMMABLE FUEL and its **EXPLOSIVE VAPORS** can result in death or serious injury.

Handle fuel with extreme care. **ALWAYS** use an approved fuel container.

No Smoking! No Lighted Materials!
No Open Flames!
Allow engine to cool before any service.

To add fuel to Fuel Tank:

1. **ALWAYS** place unit in open or well ventilated area.
 2. Stop engine and allow to cool.
 3. Clean Fuel Cap and surrounding area to prevent dirt from entering Fuel Tank (Figure 4).
 4. Remove Cap.
- IMPORTANT:** See Engine Manual for correct type and grade of fuel.
5. Fill fuel tank to within 1/2" (3,1 cm) below bottom of filler neck with unleaded gasoline. Tank capacity is 1 gallon (3,8 liters).
 6. Replace Fuel Cap and tighten.
 7. **ALWAYS** clean up any spilled fuel.

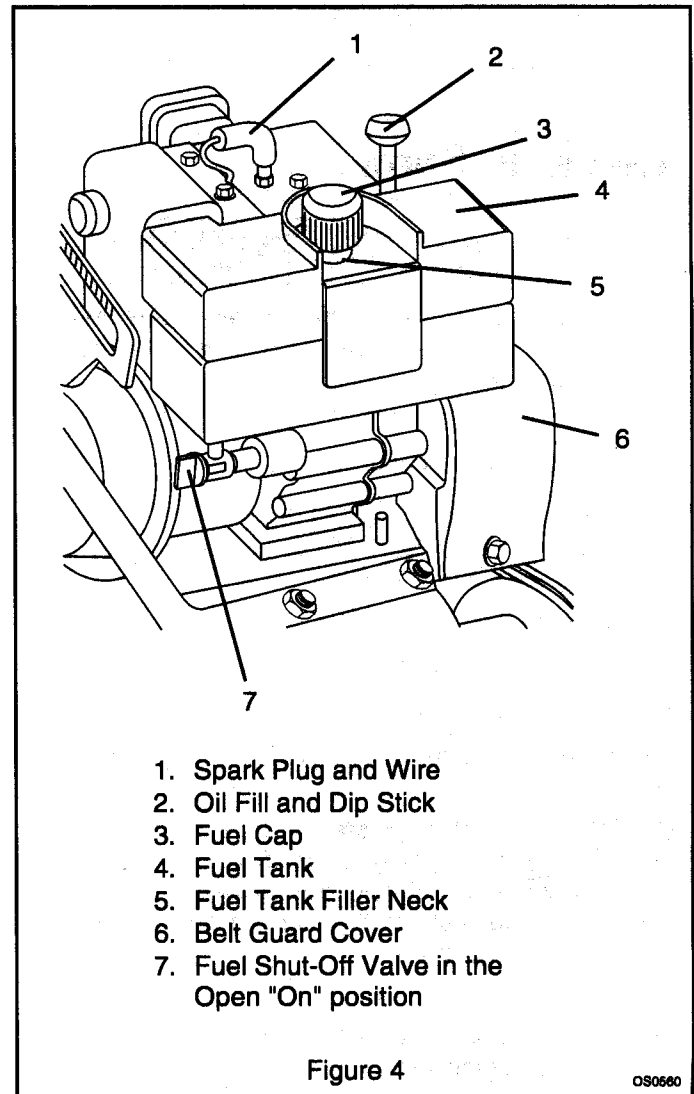

FUEL SHUT-OFF VALVE

IMPORTANT: The unit is equipped with a gravity feed type of fuel system. If the Fuel Shut-Off Valve is not in the closed "Off" position, gasoline can leak out of the carburetor while the unit is being transported.

The unit engine Fuel Shut-Off Valve has 2 positions:

1. Closed "Off"
2. Open "On"

ALWAYS close or turn the Fuel Shut-Off Valve to the "Off" position for servicing, transporting or storing the unit.

The unit must have the Fuel Shut-Off Valve in the open "On" position for proper fuel delivery to the engine during normal operation (Figure 4).

Check the Fuel Shut-Off Valve frequently to assure it is in the proper position for operation or service.

ENGINE

Cooling

The Engine is air cooled. Air must circulate freely around engine from Air Intake to cooling fins on cylinder head and block, to prevent overheating (Figure 5).

Each year (more often if conditions require) remove cooling shrouds and clean cooling fins. Clean external surfaces of engine of dust, dirt and oil deposits which can contribute to improper cooling. See Engine Manual.

IMPORTANT: DO NOT operate engine with cooling shrouds removed or engine overheating and damage will result.

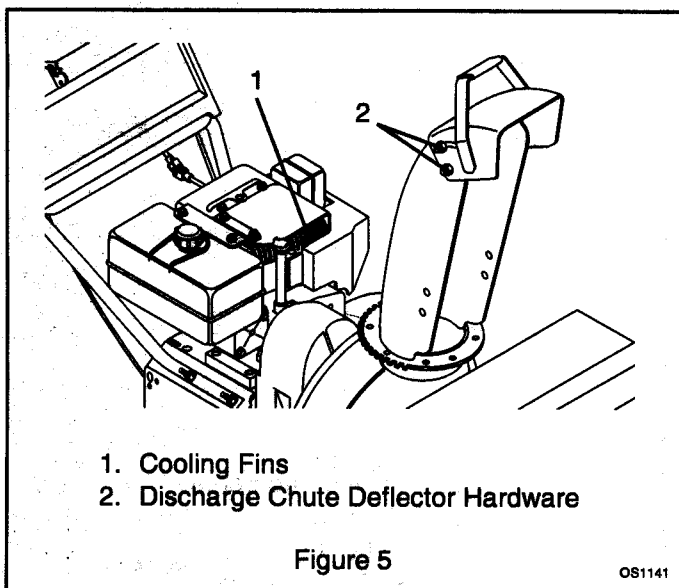

Engine Oil Check

The engine crankcase oil should be checked daily or every 5 hours of operation. Oil level MUST be maintained in safe operating range on dipstick at all times or engine damage will result (See Engine Manual).

To check, park unit of a flat, level surface and:

1. Clean all debris away from around oil cap.
2. Remove oil cap and dipstick. Wipe oil off dipstick with a clean cloth. Replace dipstick until cap bottoms on tube. Remove dipstick again and observe oil level. Oil should be at the Full (F) mark.
3. If low, add oil and bring up to the Full (F) mark.

IMPORTANT: DO NOT over fill. Oil Level must not exceed full (F) mark.

Engine Oil Type	Ambient Temperature
SAE 5W30	Below 32° F (0° C)
SAE 30	Above 32° F (0° C)

4. Replace dipstick and cap. Clean up any spilled oil.

Engine Oil Change

Change oil after first 5 hours of operation, thereafter change oil every 25 hours (more often if required).

NOTE: Run engine just prior to changing oil. Warm oil will flow more freely and carry away more contamination.

1. Drain crankcase by removing oil drain plug (see Engine Manual).
2. When oil has drained replace plug and refill engine crankcase with new oil of proper grade.
3. Recheck oil level with dipstick.

TRACTION DRIVE BELT

WARNING



ROTATING PARTS can cut off body parts. Keep hands and feet away. Loose clothing, long hair or scarves can get caught in rotating parts and cause death or serious injury.

NOTE: Housing and frame must be tipped apart and attachment drive belt removed from engine sheave in order to change traction drive belt (Figure 6).

1. Pull idler away from belt and remove belt from idler pulley, engine and driven pulley (it may be necessary to turn engine pulley using rewind starter).

2. Rotate belt fingers out and away from belt and pulley by removing one cap screw and loosening the other.

IMPORTANT: Use care when rotating the belt fingers to prevent deformation of parts.

NOTE: To gain clearance engage traction clutch and if necessary pull back attachment idler arm clevis pin.

3. Replace traction drive belt and belt fingers in reverse order making sure pulleys align. If alignment is necessary, loosen engine pulley set screws, reposition pulley and retighten set screws. Check alignment of attachment driven pulley and align if necessary.
4. Check and adjust clutch.

ATTACHMENT DRIVE BELT

WARNING

IMPROPER ADJUSTMENT could result in death or serious injury. **IMPELLER BRAKE MUST DISENGAGE** when clutch is engaged. Brake must be at least 1/16" (1,6 mm) to 1/8" (3,2 mm) minimum from belt when disengaged.

For Attachment Drive Belt Replacement (Figure 7):

1. Shut off engine and allow to cool completely.

IMPORTANT: To avoid bending bottom cover when tipping unit apart: support handlebars firmly or tip unit up on housing and remove bottom cover before separating unit.

2. Remove two screws securing belt guard to unit and remove belt guard cover.
3. Remove hairpin from chute crank rod assembly at "U" joint and separate.
4. Loosen cap screws and carefully rotate belt fingers out and away from belt and pulley (Figure 6). Remove attachment drive belt (Figure 7) from engine pulley (it may be necessary to turn engine pulley using rewind starter).
5. Support handlebars. Remove cap screws securing housing to frame (one on each side). Tip housing and frame apart on pivot pin.
6. Remove attachment drive belt from sheave (hold brake away from belt).
7. Replace attachment drive belt in reverse order making sure sheaves align. If alignment is necessary, loosen attachment sheave set screws, reposition sheave and retighten set screws.
8. Check and adjust clutch.

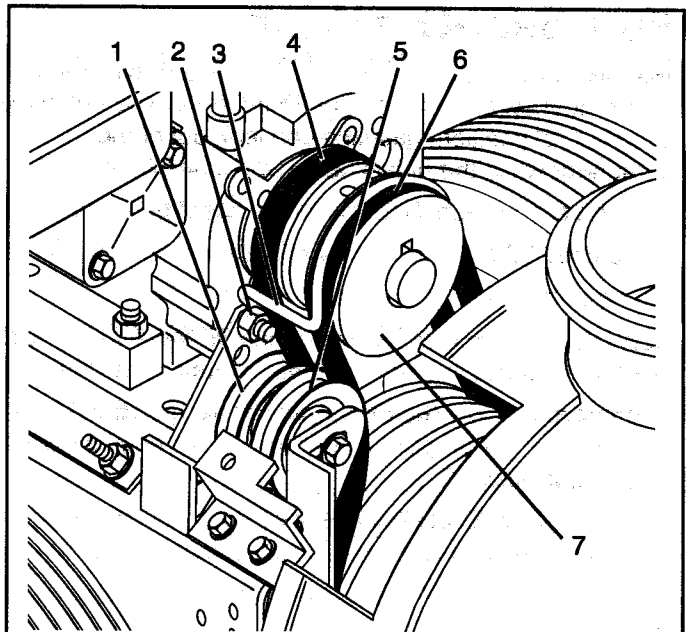

1. Traction Belt Idler
2. Cap Screw
3. Belt Finger
4. Attachment Belt Idler
5. Traction Drive Belt
6. Attachment Drive Belt
7. Engine Pulleys

Figure 6

OS0600

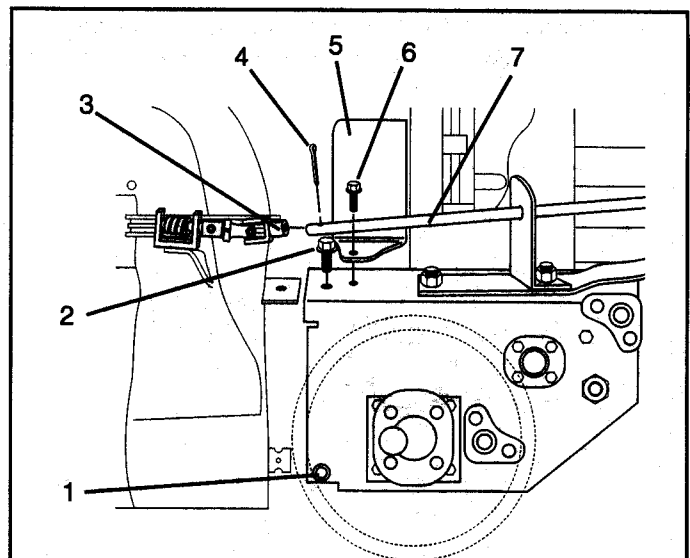

1. Pivot Pin
2. Housing Cap Screws
3. "U" Joint
4. Cotter Pin
5. Belt Guard Cover
6. Bolt
7. Chute Crank Rod

Figure 7

OS0780

SHEAR BOLTS

IMPORTANT: Use only Ariens Shear Bolts for replacement. Use of any other type of shear bolt may result in severe damage to unit.

Occasionally a foreign object may enter the auger/impeller housing and jam the auger, breaking Shear Bolts which secure the auger to the shaft (Figure 8). This allows auger to turn freely on the shaft preventing damage to gear drive.

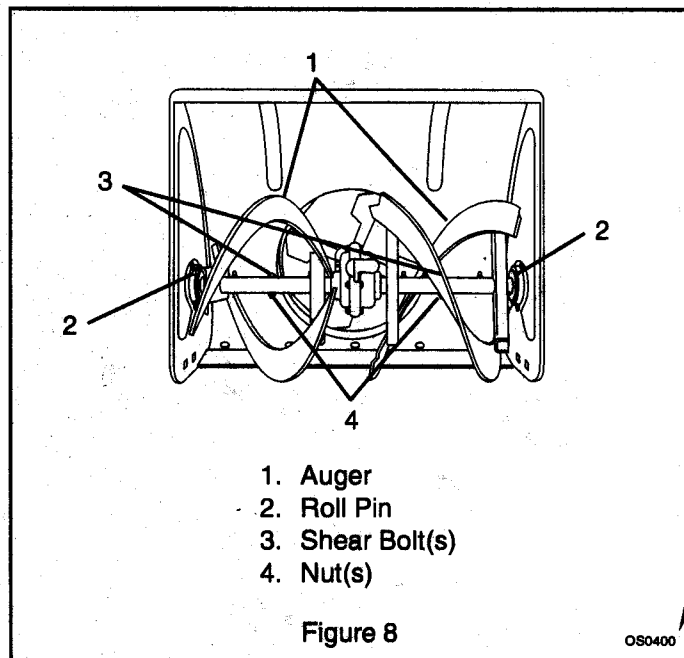

1. Auger
2. Roll Pin
3. Shear Bolt(s)
4. Nut(s)

Figure 8

OS0400

For Replacement:

1. Slide auger outward against roll pin and align hole in shaft with hole in auger (holes in shaft for roll pins and Shear Bolts line up).
2. Drive Shear Bolt through hole (if Shear Bolt was broken this will drive remaining part from shaft).
3. Secure Shear Bolt with nut.

TIRE PRESSURE

Maintain the unit tire pressure at a maximum 20 PSI (138 kPa).

FRICION WHEEL

1. To replace friction wheel, tip unit up onto housing on a flat level surface.
2. Remove bottom cover by removing four cap screws.
3. Place Speed Selector in first (1) position, depress Traction Clutch Lever to hold friction wheel and hub in position and remove cap screws. Release traction clutch lever, shift to third (3) position, disconnect the shift link, and remove friction wheel (Figure 9).

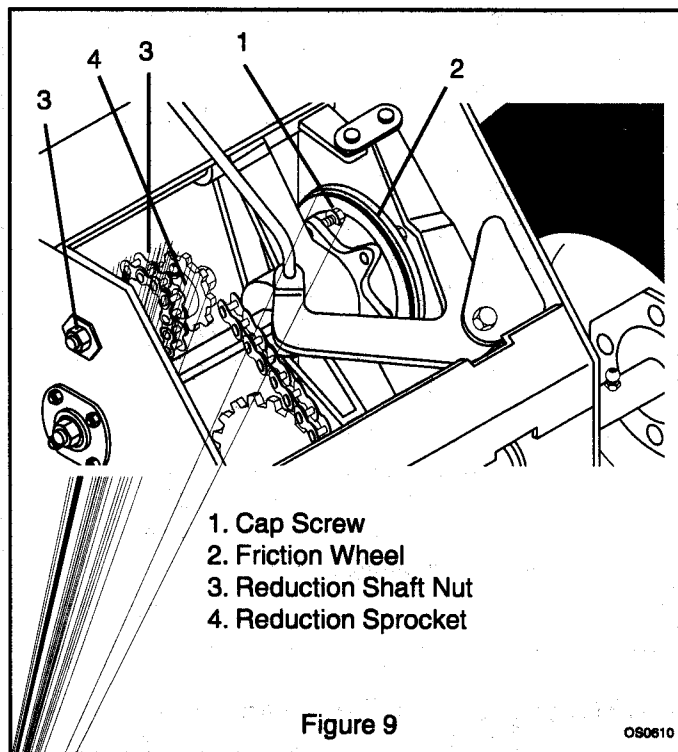

1. Cap Screw
2. Friction Wheel
3. Reduction Shaft Nut
4. Reduction Sprocket

Figure 9

OS0610

4. Secure new friction wheel on hub with five cap screws and torque cap screws to 8-10 ft. lbs. (10,6-13,3 Nm)
5. Install the shift link and replace bottom cover.
6. Adjust Traction Drive Clutch (see Adjustments).

AUGER GEARCASE

IMPORTANT: Too much lubricant may cause excessive leakage. Too little lubricant will cause gear and/or bearing damage. Proper oil level must be maintained for operation.

Gear cases are filled to the correct level at the factory. Unless there is evidence of leakage, no additional lubricant should be required. Check for evidence of leakage every 25 hours of operation.

To insure adequate lube level:

1. Remove filler plug. Lubricant must be at least up to bottom of lube filler hole with unit resting on a level surface.
2. Add lubricant, if required, allow oil to drain to level of plug and replace plug (Figure 10).
3. Use only Ariens special gear lube L-2 (Part Number 00008000).

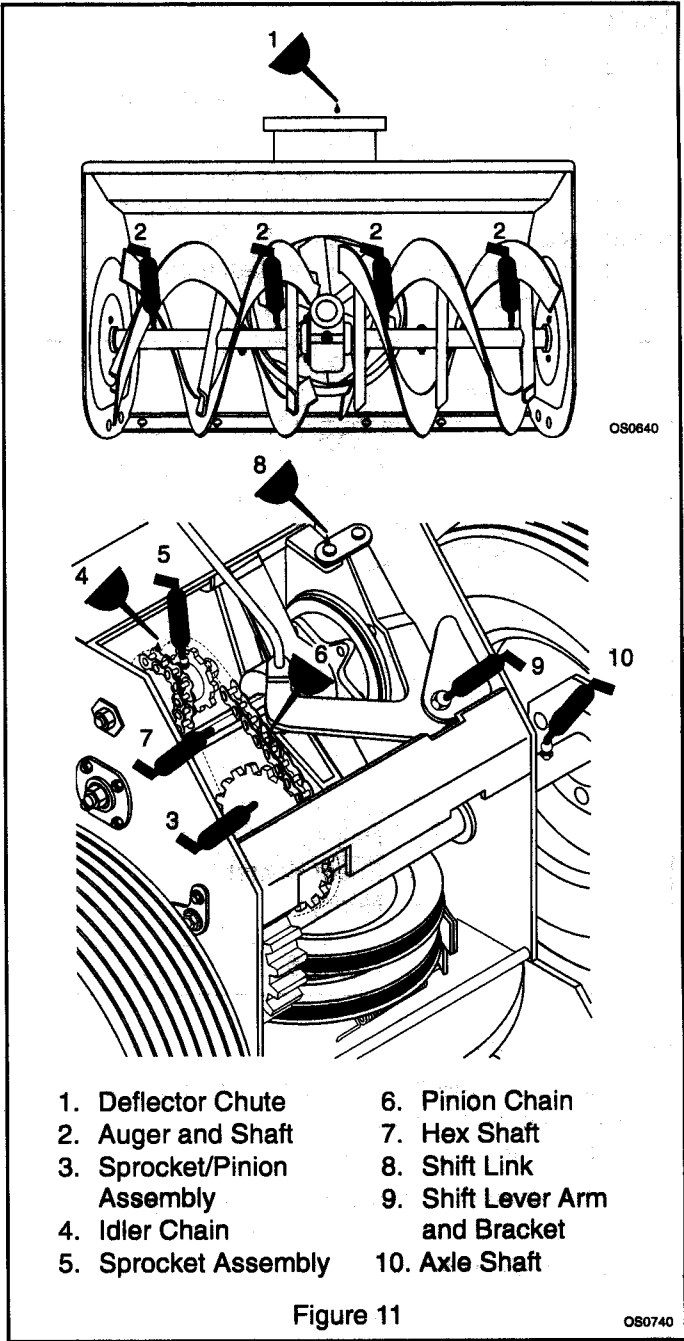
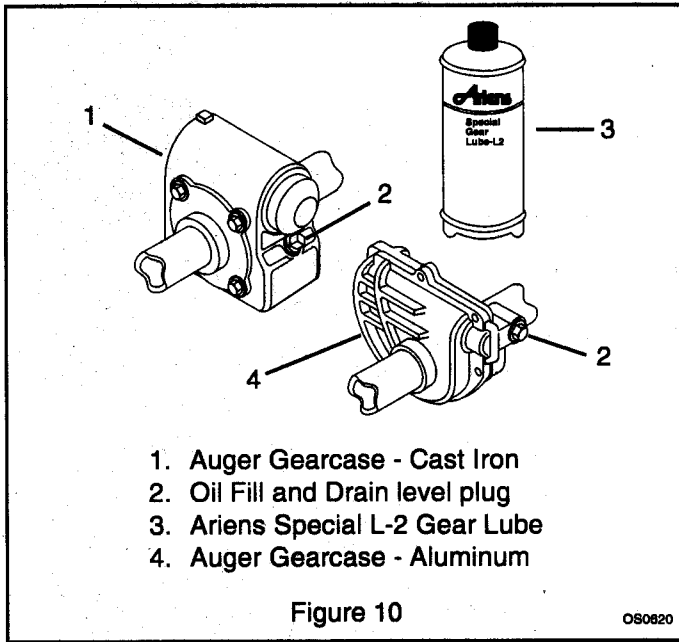

LUBRICATION LOCATIONS

WARNING

OLD100

HOT SURFACES can result in death or serious injury. **DO NOT** touch parts which are hot from operation. **ALWAYS** allow parts to cool.

IMPORTANT: Wipe each fitting clean before and after lubrication.

IMPORTANT: DO NOT allow grease or oil to get on friction wheel, drive disc or belts.

Apply **Osten Mix** Hi-Temp Grease or equivalent to the lube fittings. Order P/N: 00036800 - Three Pack of 3 oz. cartridges or 00036700 - 10 pack of 14 oz. cartridges.

Apply oil at lubrication points.

Unit should be lubricated at beginning of season or every 25 operating hours (Figure 11). See Maintenance Schedule.

NOTE: To grease auger shaft, remove shear bolt nuts, and shear bolts. Turn auger on shaft while applying grease at zerk fittings. Replace shear bolt per instructions in Shear Bolt Replacement.

ADJUSTMENTS

WARNING

ACCIDENTAL ENGINE START UP can cause death or serious injury. **ALWAYS** stop engine, remove key, wait for moving parts to stop and remove wire from spark plug before adjusting or servicing.

OLD084 STOP

Discharge Chute Deflector

To adjust, loosen then retighten hardware to desired deflector drag force (Figure 5).

Deflector Remote

Adjust as required at clevis end and/or cap pivot cable end fitting.

Runners

Runners should be adjusted as conditions require. Raising or lowering runners controls distance scraper blade (auger/impeller housing) is held above surface being cleared.

1. Position unit on a hard, flat, smooth level surface.
2. Adjust runners by inserting a spacer of desired thickness under center of scraper blade, loosen hardware, slide runners to flat surface (Figure 12). Allow 1/8" (3mm) between scraper blade and hard smooth surface. Allow 1-1/4" (30mm) between scraper blade and uneven surface(s).
3. Retighten hardware.

NOTE: Keep housing level by adjusting runners equally. Uneven runners make unit difficult to steer and results in uneven clearing.

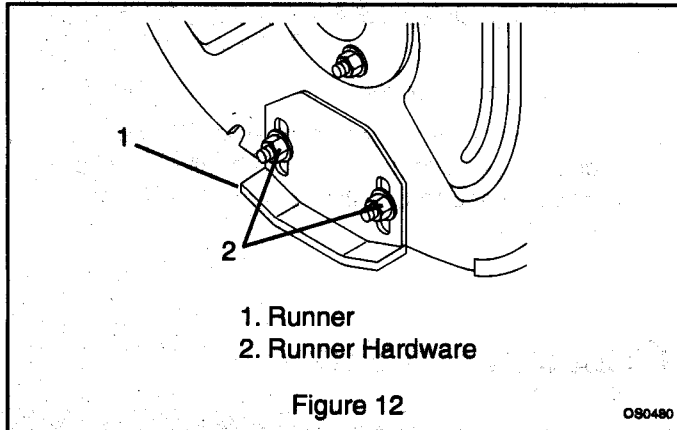

Scraper Blade

IMPORTANT: Damage to auger/impeller housing will result if blade wears down too far.

Scraper blade is adjustable to compensate for wear.

To adjust scraper blade:

1. Tip unit back onto handlebar, support housing and loosen nuts retaining blade. With runners adjusted to their full up position, reposition scraper blade down, flush with runners, and tighten lock nuts.

Chute Crank

Smooth and easy rotation of properly lubricated chute with crank (without binding) is obtained by adjusting clearance between worm (Figure 13) and discharge chute gear teeth.

1. To adjust, loosen nut on bracket supporting worm, position worm to fully engage (without binding), gear teeth on discharge chute and tighten nut.

To prevent discharge chute from rotating by itself when unit is being operated, tighten jam nuts on end of crank rod to put increased tension on worm gear.

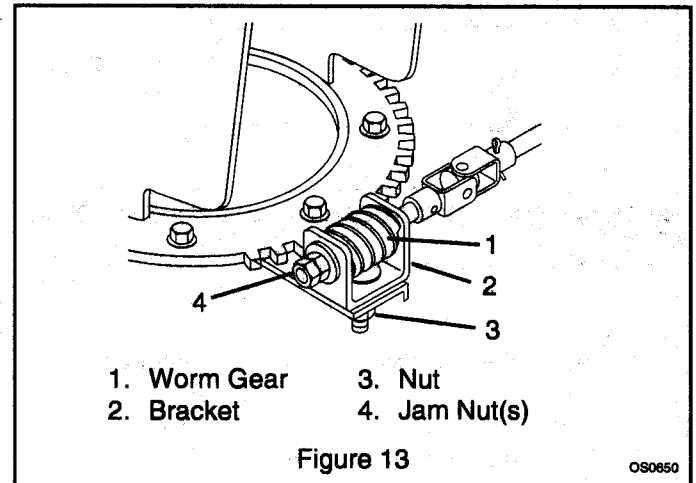

Attachment Clutch/Impeller Brake

WARNING

AUGER / IMPELLER MUST STOP within 5 seconds when Attachment Clutch / Impeller Brake lever is released or unit damage or serious injury may result.

To Adjust Attachment Clutch / Impeller Brake:

1. Remove belt cover. Adjust attachment clutch with both clutch lever and clutch arm in disengaged position. There should be a slight amount of slack in the cable to allow for brake wear.
2. Move the attachment idler toward the belt to increase spring extension. Approximately 1/8" (3,2 mm) movement of the idler will increase spring extension by 1/8" (3,2 mm). Spring should extend approximately 3/8" (9,5 mm) when clutch is engaged but allow clutch arm (at lower end) to return to its maximum down position when clutch is disengaged (Figure 14).

To check impeller brake:

3. Tip unit forward onto auger/impeller housing. Remove bottom cover by removing four cap screws.
4. Measure distance between impeller brake shoe pad and belt with attachment clutch engaged (Figure 15). Impeller brake shoe should be 1/16" (1,6 mm) minimum from belt. When attachment clutch is disengaged, brake must contact belt.

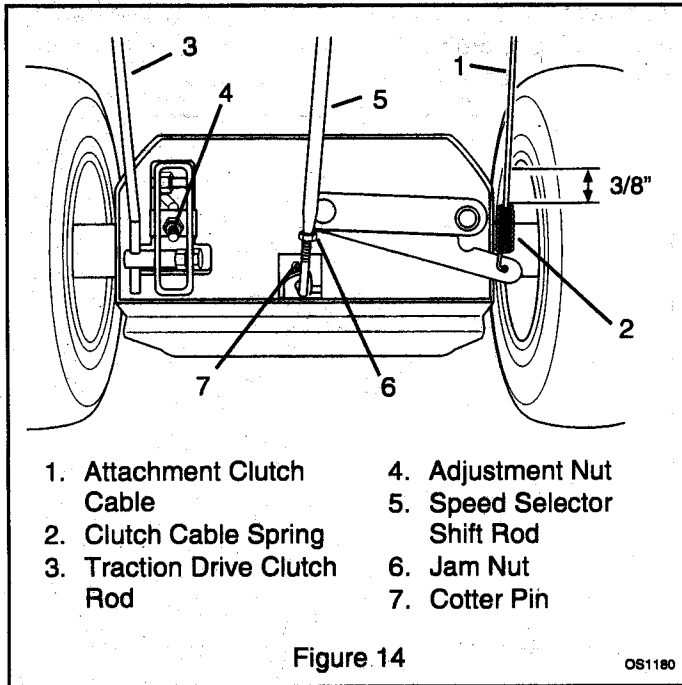

2. Remove cotter pin and pull shift rod out of chassis until it stops, put speed selector lever into reverse panel notch (Figure 14). Two notches are available, place in last notch (Figure 16).

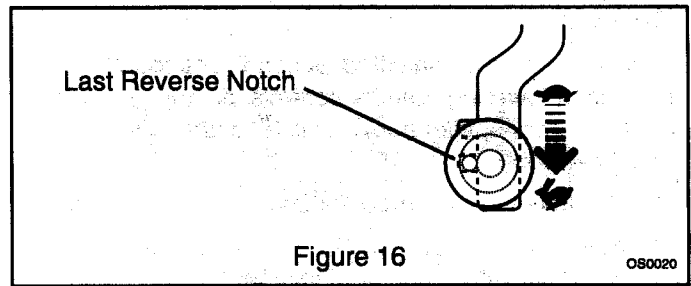

3. Adjust length of shift rod until rod end passes into hole on selector lever arm.
4. Tighten jam nut (Figure 14).
5. Install rod into arm hole and secure with cotter pin.

Drive Chain

Chain should be taut with little or no play in it. To compensate for looseness or excessive tightness in drive chain:

1. Remove bottom cover by removing four cap screws.
2. Loosen two nuts on reduction shaft (Figure 9). Move reduction sprocket up or down equally in slot as necessary and torque the nuts to 14-15 ft. lbs. (18,6 - 20,0 Nm).

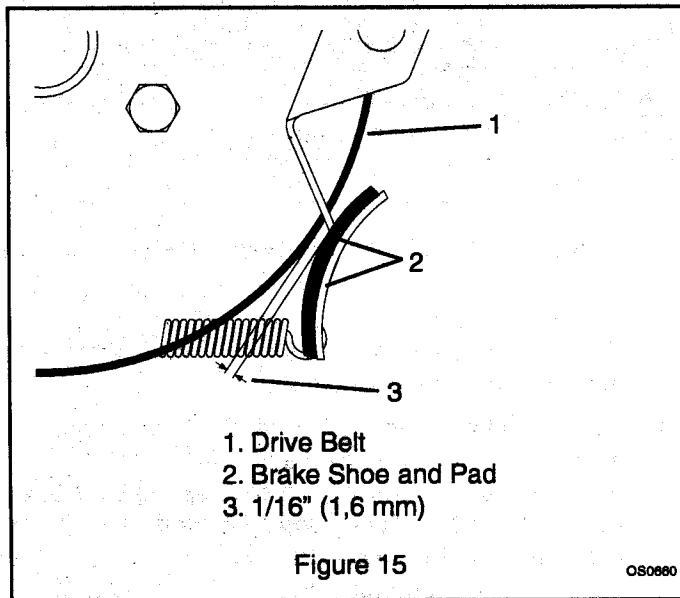

Traction Drive Clutch

Adjust traction clutch to compensate for wear of friction wheel when slippage occurs.

To adjust traction clutch, place speed selector in First (1) Forward and tip unit forward onto housing.

With traction clutch disengaged turn wheels while tightening Adjustment Nut at clutch yoke until wheels begin to drag (Figure 14). Engage and release traction clutch to align clutch linkage. Repeat as necessary. When wheel drag is obtained with linkage aligned, turn nut back three turns. Wheels will then turn freely.

Speed Selector

1. Put unit into Service Position.

CLEANING AND STORAGE

WARNING

FLAMMABLE FUEL and its **EXPLOSIVE VAPORS** can result in death or serious injury. **DO NOT** store unit inside a building with fuel in the fuel tank where any ignition sources are present. Drain fuel outdoors away from any ignition source. Allow engine to cool before storing in any enclosure. Only use approved fuel containers.

Your authorized Ariens Dealer is trained and equipped to service your unit. A periodic checkup by your dealer will help reduce your maintenance costs.

Unit

Run with Impeller Clutch engaged a few minutes after each use to free unit of any loose or melting snow.

Inspect unit for visible signs of wear, breakage or damage. Order any parts required and make necessary repairs to avoid delays when beginning use again.

Keep all nuts, bolts and screws tight and know unit is in safe working condition. Check all hardware at regular intervals.

Clean unit thoroughly and lubricate (see lubrication instructions). Touch up all unpainted areas to avoid rust and store in a cool, dry protected area.

IMPORTANT: NEVER spray unit with water or store unit outdoors to aid in prevention of rust or corrosion. Water can seep into sealed bearings, which are sealed against dirt and debris only, causing reduced component life.

Engine

When storing unit for extended periods of time, remove all fuel from tank and carburetor (run dry). Refer to Engine Manufacturer's instructions.

SERVICE MANUAL

Service manuals are available for owners who wish to perform some of their own maintenance and service. When ordering manuals, always include the Models and Serial number of your unit.

Mail requests to:

Ariens Service
655 West Ryan Street
PO Box 157
Brillion, WI 54110-0157

ATTACHMENTS

See your authorized Ariens dealer to add this additional attachment to your unit.

824011 36" Rotary Brush

ACCESSORIES

See your authorized Ariens dealer to add these additional accessories available for your unit.

Accessories:









- 72401700 ... 12V Electric Starter
- 72403600 ... 120V Electric Starter
- 72402100 ... Remote Deflector Kit
- 71099700 ... Slicer Bar
- 72407500 ... Light

Be sure to always use genuine Ariens parts to keep your Sno-Thro running like new.

MAINTENANCE SCHEDULE

The chart below shows the recommended maintenance schedule that should be performed on a regular basis. More frequent service may be required due to working conditions (heavy loads, high ambient temperatures, dusty conditions, or airborne debris).

See Engine Manuals for further maintenance and trouble shooting information.

Service Performed		Intervals			
		Daily	5 ⓧ	25 ⓧ	Yearly
	<input checked="" type="checkbox"/> Fasteners	●			
	<input checked="" type="checkbox"/> Clutch Disengagement	●			
	<input checked="" type="checkbox"/> Engine Oil		●		
	<input checked="" type="checkbox"/> Auger Gearcase for Leakage			●	
	<input checked="" type="checkbox"/> Tire Pressure			●	
	General Lubrication			●	
	Replace Engine Oil		★	●	
	Clean Cooling Fins				●

★ First Maintenance Only

OS0751

TROUBLE SHOOTING

Problem	Probable Cause
Engine will not crank	Check if Key Switch is in run position. Check for electrical problems. Solenoid not functioning.
Engine will not start	Fuel tank is empty. Ignition switch in Off position. Build up of dirt and residue around governor/carburetor. Check for electrical problems. Check for engine ignition problems - See Engine Manufacturer's Service Manual.
Engine stops	Wrong carburetor adjustment. Mechanical jam in blower rake or impeller. Check spark. Check fuel supply. Use only clean fuel.
Engine power, noise, idle and shut down	See Engine Manufacturer's Service Manual.
Does not operate in Forward/Reverse	Friction drive wheel is not adjusted properly. Drive belt is not functioning.

OS1150

MAINTENANCE RECORD

SERVICE TO BE PERFORMED		TIME INTERVALS BETWEEN SERVICE	
		25 HRS.	
		ACTUAL HOURS	
		DATE	
		50 HRS.	
		ACTUAL HOURS	
		DATE	
		75 HRS.	
		ACTUAL HOURS	
		DATE	
		100 HRS.	
		ACTUAL HOURS	
		DATE	
		125 HRS.	
		ACTUAL HOURS	
		DATE	
		150 HRS.	
		ACTUAL HOURS	
		DATE	
		175 HRS.	
		ACTUAL HOURS	
		DATE	
		200 HRS.	
		ACTUAL HOURS	
		DATE	
		225 HRS.	
		ACTUAL HOURS	
		DATE	
		250 HRS.	
		ACTUAL HOURS	
		DATE	
		275 HRS.	
		ACTUAL HOURS	
		DATE	
		300 HRS.	
		ACTUAL HOURS	
		DATE	
		325 HRS.	
		ACTUAL HOURS	
		DATE	
		350 HRS.	
		ACTUAL HOURS	
		DATE	

SNO-THRO SPECIFICATIONS

Model Number	924100	924101	924102	924103	924104	924106
Description	ST824	ST928	ST1032	ST1236	ST1028	ST1024
Engine	Tecumseh					
Power Max - HP	8	9	10	12	10	
Max Rotation Speed - RPM	3600					
Displacement - cu. in. (cc)	19.43 (318.3)			21.82 (357.6)		
Electric Start 12V Key Start	Optional					
Fuel	See Engine Manual					
Tank Capacity - qt (Liters)	4 (3.8)					
Snow Clearing Width - in (cm)	24 (61.0)	28 (71.2)	32 (81.3)	36 (91.4)	28 (71.2)	24 (61.0)
Snow Throwing Distance - ft (m)	3-30 (0.9-9.1)		5-35 (1.5-10.5)			
Chute						
Rotation Angle	230°					
Rotation Control at Handlebar	Yes					
Dual Handle Interlock	Yes					
Impeller						
Speed - RPM	1100					
Auger						
Diameter - in (cm)	15 (38.1)	16 (40.6)				
Speed - RPM	110					
Auger Brake	Yes					
Auger Clutch	Yes					
Drive	Disc-O-Matic					
Speeds	6 Forward and 2 Reverse					
Lock Out Differential	Yes					
Adjustment Skids	Yes					
Pneumatic Tires - in (cm)	4.80/4.00x8 (12.2/10.2x20.3)	16/6.50x8 (40.6/16.5x20.3)				
Size and Weight						
Length - in (cm)	60 (152)					
Height - in (cm)	40 (101.6)					
Width - in (cm)	26.3 (66.6)	30.5 (77.6)	34.5 (87.6)	34.5 (87.6)	30.5 (77.6)	26.5 (67.3)
Weight - lbs (Kg)	265 (120)	303 (138)	318 (144)	341 (155)	303 (138)	297 (135)

OS1161

Q U A L I T Y

Q U A L I T Y

P R O D U C T S

G U A R A N T E E

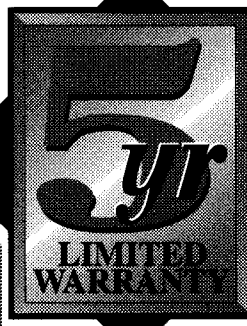

Ariens

Ariens Company hereby warrants to the original consumer purchaser that products manufactured by Ariens Company will be free from defects in material and workmanship FOR A PERIOD OF FIVE (5) YEARS FROM THE DATE OF PURCHASE, EXCEPT AS NOTED BELOW.



PROTECTION PLAN

- The Company will provide for the replacement of any part found upon examination by the Company to be defective. Such repair or replacement will be free of charge to the purchaser (labor and parts) for two years (24 months) from the date of purchase. Ariens manufactured parts (but not labor) will be free of charge for an additional three years (36 months) thereafter.



This warranty is subject to the following exceptions and limitations:



PURCHASER RESPONSIBILITIES

- Maintenance & minor adjustments per owners manual
- Notification of need for warranty service
- Transportation to/from place of warranty repair

RENTAL USE - ALL PRODUCTS

- NINETY DAYS LABOR & PARTS



PRODUCT REGISTRATION

- Return of registration card required to validate warranty

CONSUMER PRODUCT - PUT TO COMMERCIAL, INDUSTRIAL, INSTITUTIONAL USE

- NINETY DAYS LABOR & PARTS



PURCHASED COMPONENTS & NORMAL WEAR

- **Two year** labor and parts on purchased components i.e., (tractor drive train components manufactured by Dana, Eaton, Foote, Sundstrand and any plastic and electrical components, wire harness, bags, boots, tubes, etc.).
- **Two year** labor and parts on normal wear items i.e., (belts and rubber components, bearings, cables, controls, clutches, tines, etc.).

SERVICE PARTS & ACCESSORIES

- NINETY DAYS LABOR & PARTS

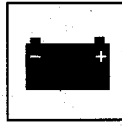

BATTERY WARRANTY PRORATED

- **One to six months - free replacement**
- Seven to twelve months - 50% credit
- Thirteen to twenty-four months - 25% credit

SERVICE

- For warranty service, contact any Ariens Distributor or Dealer. For the name and location of the Ariens Distributor or Dealers in your area, and for further warranty information, write or call Ariens Company.

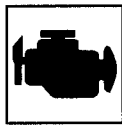

WARRANTY - COMMERCIAL PRODUCTS

- **One year** parts and labor
- Product labeled commercial/professional
- Household use - 5 year limited warranty applies

ENGINES, ENGINE ACCESSORIES, & PEERLESS PRODUCTS

- Covered only by manufacturer's warranty



EXCLUSIONS

- No warranty is extended to blades, mower vanes, skid shoes, runners, scraper blades, shear bolts, light bulbs, headlights and any equipment which has been altered, misused, misassembled, improperly adjusted, neglected, or damaged by accident.
- No warranty is extended for service completed by anyone other than an authorized distributor or dealer.
- No warranty is extended on any parts that are not genuine Ariens service parts.
- Ariens Company reserves the right to incorporate any changes in design into its products without obligation to make such changes on products previously manufactured.



DISCLAIMER OF FURTHER WARRANTY

There is no other express warranty. Implied warranties, including any warranty of merchantability or fitness for a particular purpose, are limited to the duration of this written warranty, and are excluded to the extent permitted by law. There are no warranties which extend beyond the description of the product contained herein. In no event shall the company be liable for indirect, special or consequential damages (such as loss of anticipated profits)

in connection with the consumer's use of the product. This warranty gives you specific legal rights, and you may also have other rights which vary from state to state. Some states do not allow the exclusion of incidental or consequential damages, or limitations on how long an implied warranty lasts, so the above limitation and exclusions may not apply to you.

Ariens®

655 West Ryan Street • P.O. Box 157 • Brillion, WI 54110-0157 • 920-756-2141 • Fax 920-756-4421

***Ask Your Dealer For Information On
These Other Fine Ariens Products***

- **Front and Rear Tine Tillers**
- **Walk-Behind Lawn Mowers**
- **Zero-Turning Radius Mowers**
- **Rear Engine Riding Mowers**
- **Yard and Garden Tractors**
- **Commercial Walk-Behind and Riding Mowers**
- **Sno-Thros**