



The Bose® Acoustimass® 10 Series II Home Theater Speaker System

*Owner's Guide
October 22, 2001*

AM194646_02_V.pdf

Thank you

We appreciate your choice of the Bose® Acoustimass® 10 Series II home theater speaker system. With these Virtually Invisible® speakers you'll surround yourself with realistic sound, without a lot of equipment. Your system features new third generation Acoustimass cube speaker arrays, a product of the continuous research and development at Bose Corporation. These cube speakers deliver more lifelike sound and better overall performance, yet are smaller than their predecessors.

Important information

Please read this owner's guide

The set-up and operation of your Acoustimass 10 Series II speaker system is significantly different from other speakers. Please take the time to read this owner's guide carefully. It will help you set up and operate your system properly, and enjoy all of its advanced features. Save your owner's guide for future reference.

Declaration of Conformity



We, the offerer:
Bose® Corporation, The Mountain,
Framingham, MA 01701-9168 USA
acknowledge our sole responsibility, that the product:

Kind of equipment:	Loudspeakers
Type designation:	Acoustimass® 10 Series II Home Theater Speakers

in accordance with EMC Directive 89/336/EEC and Article 10(1) of the Directive,
is in compliance with the following norm(s) or document(s):

Technical regulations:	EN50081-1, EN50082-1
------------------------	-----------------------------

Accredited by Bose Corporation

1 May 1998

A handwritten signature in black ink, appearing to read 'Anton Schalkamp', written over a horizontal line.

Bose B.V., Nijverheidstraat 8
1135 GE Edam, The Netherlands

Anton Schalkamp
General Manager, Bose Europe
Manufacturer's authorized EU representative

1. **Read these instructions** – for all components before using this product.
2. **Keep these instructions** – for future reference.
3. **Heed all warnings** – on the product and in the owner's guide.
4. **Follow all instructions.**
5. **Do not use this apparatus near water or moisture** – Do not use this product near a bathtub, washbowl, kitchen sink, laundry tub, in a wet basement, near a swimming pool, or anywhere else that water or moisture are present.
6. **Clean only with a dry cloth** – and as directed by Bose® Corporation. Unplug this product from the wall outlet before cleaning.
7. **Do not block any ventilation openings. Install in accordance with the manufacturer's instructions** – To ensure reliable operation of the product and to protect it from overheating, put the product in a position and location that will not interfere with its proper ventilation. For example, do not place the product on a bed, sofa, or similar surface that may block the ventilation openings. Do not put it in a built-in system, such as a bookcase or a cabinet that may keep air from flowing through its ventilation openings.
8. **Do not install near any heat sources, such as radiators, heat registers, stoves or other apparatus (including amplifiers) that produce heat.**
9. **Do not defeat the safety purpose of the polarized or grounding-type plug. A polarized plug has two blades with one wider than the other. A grounding-type plug has two blades and a third grounding prong. The wider blade or third prong are provided for your safety. If the provided plug does not fit in your outlet, consult an electrician for replacement of the obsolete outlet.**
10. **Protect the power cord from being walked on or pinched, particularly at plugs, convenience receptacles, and the point where they exit from the apparatus.**
11. **Only use attachments/accessories specified by the manufacturer.**
12. **Use only with the cart, stand, tripod, bracket or table specified by the manufacturer or sold with the apparatus. When a cart is used, use caution when moving the cart/apparatus combination to avoid injury from tip-over.**
13. **Unplug this apparatus during lightning storms or when unused for long periods of time** – to prevent damage to this product.
14. **Refer all servicing to qualified service personnel. Servicing is required when the apparatus has been damaged in any way: such as power-supply cord or plug is damaged; liquid has been spilled or objects have fallen into the apparatus; the apparatus has been exposed to rain or moisture, does not operate normally, or has been dropped** – Do not attempt to service this product yourself. Opening or removing covers may expose you to dangerous voltages or other hazards. Please call Bose to be referred to an authorized service center near you.
15. **To prevent risk of fire or electric shock, avoid overloading wall outlets, extension cords, or integral convenience receptacles.**
16. **Do not let objects or liquids enter the product** – as they may touch dangerous voltage points or short-out parts that could result in a fire or electric shock.
17. **See product enclosure for safety related markings.**

Information about products that generate electrical noise

If applicable, this equipment has been tested and found to comply with the limits for a Class B digital device, pursuant to Part 15 of the FCC rules. These limits are designed to provide reasonable protection against harmful interference in a residential installation. This equipment generates, uses, and can radiate radio frequency energy and, if not installed and used in accordance with the instructions, may cause harmful interference to radio communications. However, this is no guarantee that interference will not occur in a particular installation. If this equipment does cause harmful interference to radio or television reception, which can be determined by turning the equipment off and on, you are encouraged to try to correct the interference by one or more of the following measures:

- Reorient or relocate the receiving antenna.
- Increase the separation between the equipment and receiver.
- Connect the equipment to an outlet on a different circuit than the one to which the receiver is connected.
- Consult the dealer or an experienced radio/TV technician for help.

Note: Unauthorized modification of the receiver or radio remote control could void the user's authority to operate this equipment.

This product complies with the Canadian ICES-003 Class B specifications.



18. **Use proper power sources** – Plug the product into a proper power source, as described in the operating instructions or as marked on the product.
19. **Avoid power lines** – Use extreme care when installing an outside antenna system to keep from touching power lines or circuits, as contact with them may be fatal. Do not install external antennas near overhead power lines or other electric light or power circuits, nor where an antenna can fall into such circuits or power lines.
20. **Ground all outdoor antennas** – If an external antenna or cable system is connected to this product, be sure the antenna or cable system is grounded. This will provide some protection against voltage surges and built-up static charges.
Section 810 of the National Electrical Code ANSI/NFPA No. 70 provides information with respect to proper grounding of the mast and supporting structure, grounding of the lead-in wire to an antenna discharge unit, size of grounding conductors, location of antenna-discharge unit, connection to grounding electrodes, and requirements for the ground electrode. Refer to the antenna grounding illustration on this page.

Antenna grounding

Example of antenna grounding as per National Electrical Code, ANSI/NFPA 70.

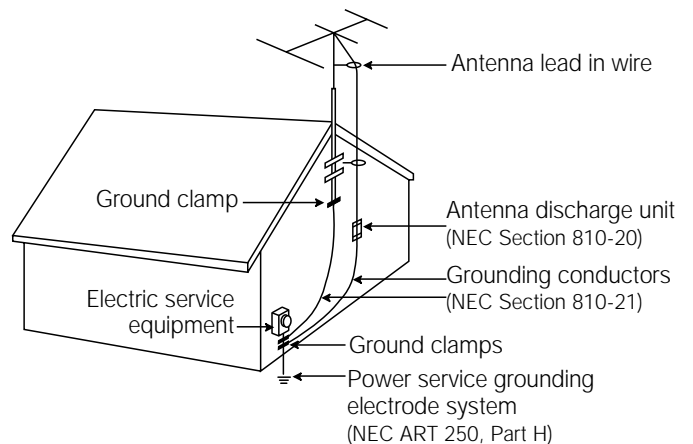

Note to CATV system installer

This reminder is provided to call the CATV system installer's attention to Article 820-40 of the NEC (of USA) that provides guidelines for proper grounding. In particular, it specifies that the cable ground shall be connected to the grounding system of the building, as close to the point of cable entry as is practical.

BOSE[®]
Better sound through research[®]

©2001 Bose Corporation,
The Mountain, Framingham, MA
01701-9168 USA
255805 AM Rev.00 JN10494

Where to find...

Introduction
 Thank you 2
 Important Information 2

Contents
 Where to find... 3
 For your records 3

Setting Up
 Before you begin 4
 Unpacking the carton 4
 Placing your Acoustimass® 10 Series II speakers to achieve
 realistic home theater sound 5
 Selecting the locations for your speakers 6
 Connecting the speakers 9

Using Your Acoustimass 10 Series II speaker system
 For realistic home theater sound 13

Maintaining Your Acoustimass 10 Series II speaker system
 Troubleshooting 14
 Customer service 14
 Cleaning the speakers 15
 Warranty period 15
 Accessories 15

Product Information
 Technical information 16

Bose® Corporation inside back cover

For your records

The serial number is located near the connection panel on the Acoustimass module.

Serial number: _____

Dealer name: _____

Dealer phone: _____ Purchase date: _____

We suggest you keep your sales slip and warranty card together with this owner's guide.

Before you begin

Bose® Virtually Invisible® speaker technology allows you to enjoy lifelike home performances from the very latest surround-sound encoded movies, CDs, and television shows, without a room full of speakers.

Your stereo VCR or stereo television sends the encoded program material to the surround-sound receiver, which interprets it by distributing various sounds to particular speakers. Although the sound mix varies with different types of programs, dialogue is usually sent to the center speaker while sounds from the left or right side of the picture go to the left or right front speakers. Ambient sounds and special effects are directed to one or both of the surround (rear) speakers. The unique, easy-to-hide Acoustimass® module delivers bass for all channels. At any point in surround-sound performance, you may hear sound from all or just a few of the speakers.

To select surround-encoded program material, look for any of the terms Surround, Dolby Surround, and the double-D symbol  **DOLBY SURROUND*** on tapes and discs, and the word “surround” preceding a TV broadcast. Your Acoustimass 10 Series II home theater speakers are also compatible with Dolby Digital* (also known as AC-3) receivers and program material. The special settings for Dolby Pro-Logic and Dolby Digital receivers are described on page 13.

You can also enjoy a wide variety of stereo programming that is not surround-encoded with your Acoustimass 10 Series II speakers. Simply adjust your receiver accordingly.

Unpacking the carton

- Remove any staples from the opened carton flaps.
- Remove the brown inner cartons containing the five cube speaker arrays and the Acoustimass module terminal cover.
- Gently roll the carton over onto its side and then onto its opening.
- Carefully lift the carton from around the Acoustimass module and packing cushions.
- Do not detach the removable cables connected to the Acoustimass module.
- If the speakers or the Acoustimass module appear damaged, do not use them. Repack everything in the original carton and contact your authorized Bose dealer immediately.



WARNING: The Acoustimass module weighs 28.7 pounds (13 kg). Use good lifting practice to avoid injury.



WARNING: To avoid danger of suffocation, keep the plastic bags that wrap these speakers out of the reach of children.

* Dolby, Dolby Digital, Dolby Pro-Logic, the double-D symbol, and Dolby Digital (AC-3) are trademarks of Dolby Laboratories Licensing Corporation.

 *Note: Now is a good time to record the serial number of the Acoustimass® module on page 3 of this guide and on your warranty card. It is a good idea to save all packing materials for possible future use.*

Figure 1

What comes in the carton:

- Acoustimass module
- Module end cover
- 5 cube speaker arrays
- 20' (6 m) speaker input cable
- 20' (6 m) front speaker output cable
- 50' (15 m) rear speaker output cable
- 8 protective rubber feet
- Owner's guide
- Quick set up guide

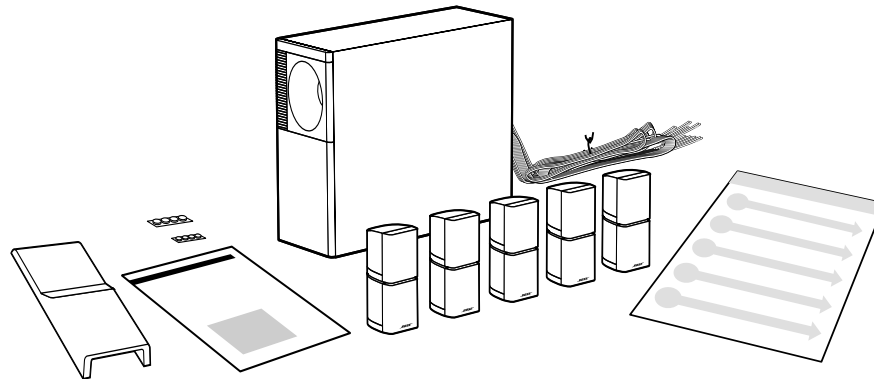

Placing your Acoustimass 10 Series II speakers to achieve realistic home theater sound

The center speaker localizes action and dialogue on your screen. Sound from the center speaker should seem to come from within the picture.

The left and right front speakers create a sound image wider than the screen that seems natural to viewers sitting anywhere in the room.

The surround speakers add subtle sounds and special effects that expand the visual image, bringing the viewer into the center of the action. The surround speakers should be positioned to allow the sound to reach the viewer from both sides, rather than from directly behind.

You can place the front and center speakers near a TV screen with no picture interference, because all of the cube speakers are magnetically shielded. You can use any of the five cube arrays at any location.

The Acoustimass module is not magnetically shielded and should be at least 2 feet (.6 m) from your screen, but at the same end of the room as the front and center speakers. Bose® Acoustimass speaker technology takes advantage of the fact that the source of bass sound is difficult to locate, so you can hide the Acoustimass module conveniently out of sight.

A suggested home theater layout that conforms to the guidelines described above is shown in Figure 2. Twist the pairs of cube speakers so they describe angles that create room-filling sound patterns.

You may choose to place the speakers differently, to take advantage of the sound characteristics of different rooms. Your speakers come with sufficient cable lengths to allow you to have the following distances between components:

- Up to 20 feet (6 m) between the Acoustimass® module and the receiver.
- Up to 20 feet (6 m) between the Acoustimass module and the front and center cube speakers.
- Up to 50 feet (15 m) between the Acoustimass module and the surround speakers.

Bose wall brackets and floor stands can extend your placement options. See “Accessories” on page 15.

♪ *Note: Please follow wall bracket instructions carefully. Proper mounting will insure optimum performance from your system.*

Figure 2

One suggested home theater layout

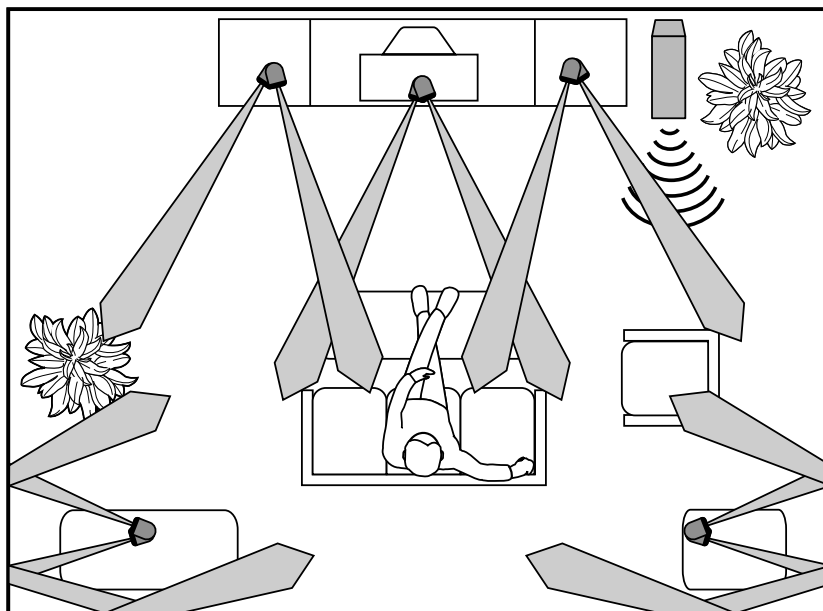

Selecting the locations for your speakers

The cables provided with your Acoustimass 10 Series II system vary in length, allowing a great deal of flexibility in speaker placement. Use the following placement suggestions as general guidelines. Choose convenient speaker locations that give you good sound.

Left and right front cube speakers

Figure 3 shows suggested ways to achieve an accurate left and right sound image.

- Place the front speakers on either side of your TV, at least 6 feet (2 m), or as much as 15 feet (5 m) apart.
- Place them in line with the center of the screen for the best sound balance (position 1). You can also place them diagonally as shown below in position 2. Placing them in a line above the top of the TV is a third choice (position 3).
- The speaker on the left as you face the TV is connected to the LEFT FRONT output jack on the Acoustimass® module.

Figure 3

Suggested choices for left and right front speaker placement

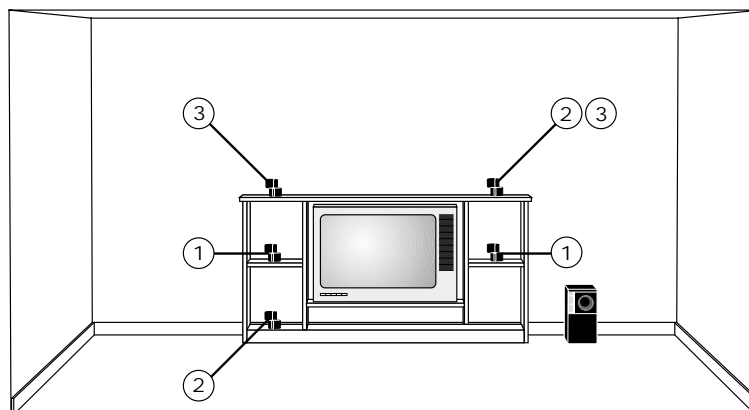

Center cube speaker

Sound from the center speaker should seem to come from within the picture.

Figure 4 shows suggested positions for the center speaker.

- Place the center cube speaker above, below, or on top of your television. If below, be sure that the cube speaker is not supporting the weight of the television in any way.
- Keep it as close to the vertical center of the screen as possible, for the most accurate dialogue reproduction (positions 1 or 2).



CAUTION: If you are placing the center speaker on top of the television, use the smaller of the two sets of four rubber feet provided. This will also provide extra stability on surfaces such as marble or glass. Additional rubber feet are available, free, by calling the Bose® customer service numbers inside the back cover of this manual. Ask for Part Number 178321-04.

Figure 4

Suggested choices for center speaker placement

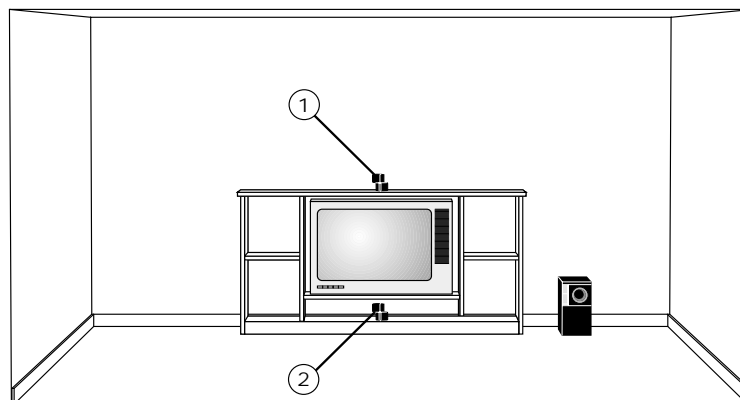

Surround cube speakers

The left and right rear channel sound should reach the viewer from both sides, rather than from directly behind. Refer to Figure 5.

- Put one on the left and the other on the right, beside or just to the rear of the home theater seating area.
- Place them high up, to avoid a direct sound path to the ears of the listeners (position 1).
- If you want the speakers located as shown in positions 2 and 3, make sure they are not directed at the viewers.
- The rear speaker on the left as you face the TV is connected to the LEFT SURROUND output jack on the Acoustimass® module.

Figure 5

Suggested choices for surround (rear) speaker placement

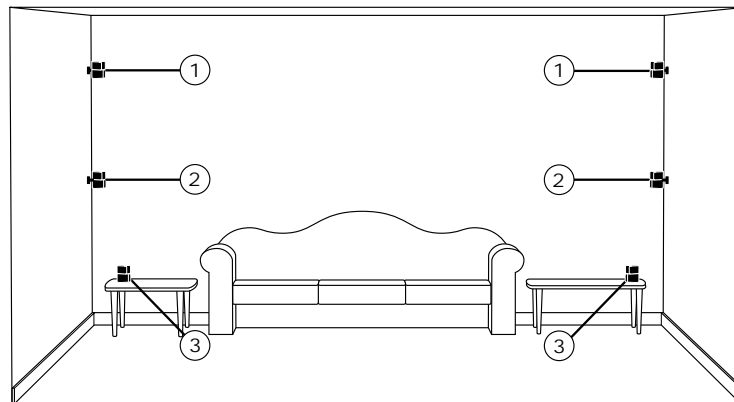

Acoustimass module

Bose® recommends putting your Acoustimass module at the same end of the room as the television monitor. To prevent interference, keep the module at least 2 feet (.6 m) from the television.

- You may hide the Acoustimass module behind or under furniture, but do not block the opening. Be sure there is at least 2 inches (5 cm) between the opening and any surface.
- If the opening faces the wall it increases the bass; if it faces away it decreases the bass. For the most bass response, place the opening 2 to 3 inches (5 to 8 cm) from a wall or corner.
- Stand the Acoustimass module vertically or horizontally (Figure 6). To stand it on the cable connection end, remove the cover by gently pulling it away.

After selecting a place for the Acoustimass module, attach the larger set of four rubber feet to the bottom surface for additional stability. The feet protect the cable connections and must be mounted when the Acoustimass module is standing on that end.

Figure 6

Acoustimass module positions

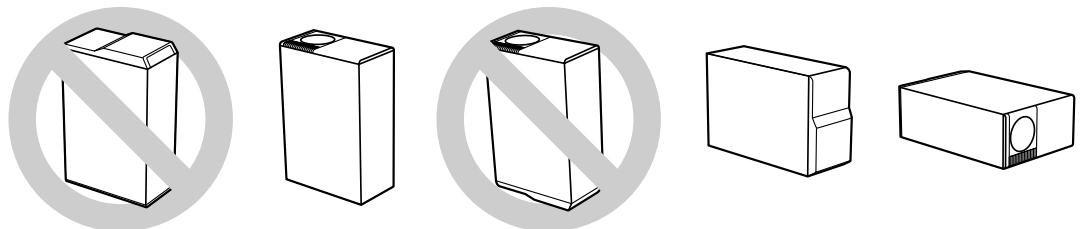

Connecting the speakers

The supplied cables make it easy for you to connect your system. The connections at the Acoustimass® module are already made for you. There are three sets of cables, joined together to form ribbons, which may be separated or “unzipped” as much as needed to comfortably reach the speakers (Figure 7). Separate the cables as you are laying out the cable lengths.

- The 20 foot (6 m) cable with *three pairs of wires* connects the Acoustimass module to the **center, left, and right front** cube speakers.
- The 50 foot (15 m) cable with *two pairs of wires* connects the Acoustimass module to the **left and right surround** cube speakers.
- The 20 foot (6 m) cable with *five pairs of wires* connects the Acoustimass module to the **outputs on the receiver**. Separate these wires just enough to reach the connectors.

Figure 7

Separating cables

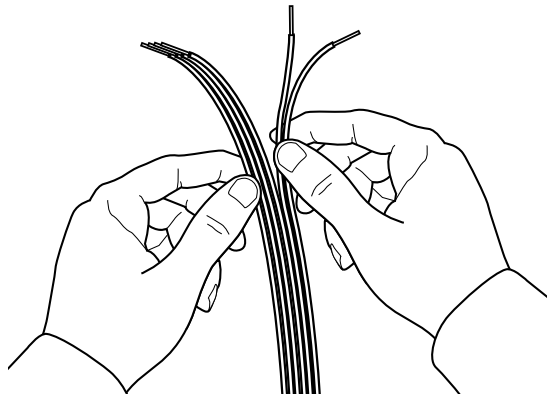

CAUTION: Before making any connections turn off your receiver or amplifier and unplug it from the outlet (AC power mains). Not doing so may result in damage to your system. Never connect the cubes directly to a receiver output. Always connect the cube speakers to the Acoustimass module, then connect the Acoustimass module to the receiver. Never use broken or frayed wiring, which can result in electrical shock or damage to your system. The supplied cables are not intended for in-wall installation. Check local building codes or enlist a qualified installer.

♪ *Note: If you want to use other speaker cable or need to lengthen the supplied cables, call Bose® customer service. See page 15 for descriptions of applicable accessories. The customer service numbers can be found inside the back cover.*

Connect the Acoustimass® module to the center and front cube speakers

Use the 20 foot (6 m) cable with *three pairs of wires* to connect the Acoustimass module to the center and front cube speakers.

♪ *Note: You can use any cube array in any position.*

1. Connect the wire pair marked **CENTER** to the cube array you have placed in the center speaker position. Press the terminal tab on the back of each speaker. Then, insert the marked wire into the red terminal and the plain wire into the black terminal. Release the tab to secure the wires in place. See Figure 8.
2. Connect the wire pair marked **RIGHT** to the cube array you have placed in the right front position (to the right of the TV as you face it) in the same way.
3. Connect the wire pair marked **LEFT** to the cube array you have placed in the left front position (to the left of the TV as you face it).

Figure 8

Making cube speaker connections

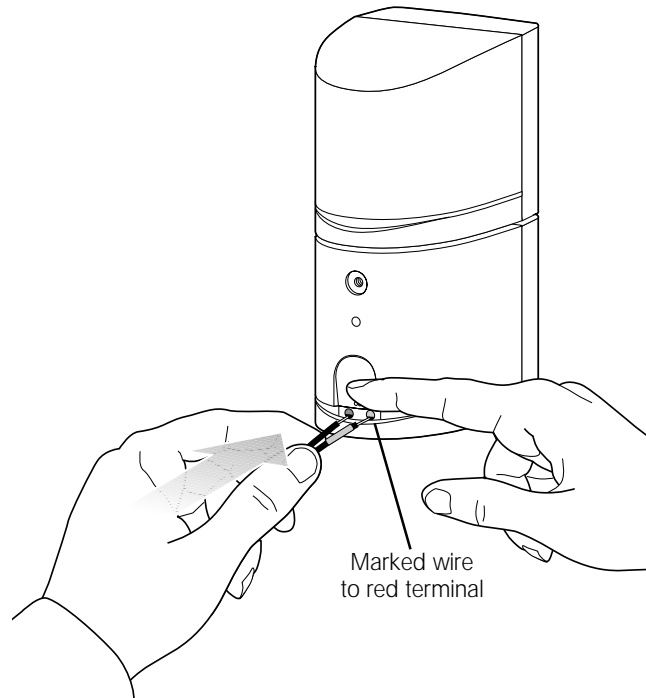

Connect the Acoustimass® module to the surround cube speakers

Use the 50 foot (15 m) cable with *two pairs of wires* to connect the **Right and Left surround** cube speakers to the Acoustimass module.

1. Use the wire marked **RIGHT SURROUND** to connect the module to the right surround speaker (on your right as you face the TV). As shown in Figure 8, press the terminal tab on the back of the speaker to insert the marked wire into the red terminal and the plain wire into the black terminal. Release the tab to secure the wires in place.
2. The wire marked **LEFT SURROUND** connects the module to the left surround speaker. Press the terminal tab on the back of the speaker to insert the marked wire into the red terminal and the plain wire into the black terminal. Release the tab to secure the wires.

Connect the Acoustimass module to the receiver

Use the 20 foot (6 m) cable with *five pairs of wires* to connect the Acoustimass module to your surround-sound receiver.

1. Match the wire labels to the SPEAKER OUTPUT labels on the receiver:
 - a. **RIGHT** wires go to the Right Front SPEAKER OUTPUT connections.
 - b. **CENTER** wires go to the Center SPEAKER OUTPUT connections.
 - c. **LEFT** wires go to the Left Front SPEAKER OUTPUT connections.
 - d. **RIGHT SURROUND** wires to the Right Surround (rear) SPEAKER OUTPUT connections.
 - e. **LEFT SURROUND** wires go to the Left Surround (rear) SPEAKER OUTPUT connections.
2. Match the polarity on the receiver. Connect the wire pairs in phase (+ to + and – to –).
 - a. Attach each marked wire (+) to the appropriate positive (+) terminal.
 - b. Attach each plain wire (–) to the appropriate negative (–) terminal.
3. At the Acoustimass module, check to make sure all RCA connectors are firmly inserted into the proper INPUT FROM RECEIVER OR AMPLIFIER jacks.

 *Note: "Front" speakers may also be called "Main", "A", or "1" by some receiver manufacturers. "Surround" speakers may be called "Rear".*

 **CAUTION:** *Do not connect the Acoustimass module directly to your television unless the television provides surround decoding circuitry and amplified outputs for all channels.*

Check the connections

Check all connections from the receiver to the Acoustimass® module and the module to the cube speakers (Figure 9). Make sure all speakers are connected to the proper terminals according to their position in your room.

At the receiver, check that the wires are connected in phase (+ to + and – to –). Incorrect wiring can result in a total loss of Acoustimass module output.

Be sure to correct any wiring problems before you plug your receiver in and turn it on.



CAUTION: Do not allow exposed wires to brush against each other; this could damage your receiver.

Figure 9

Completed connections

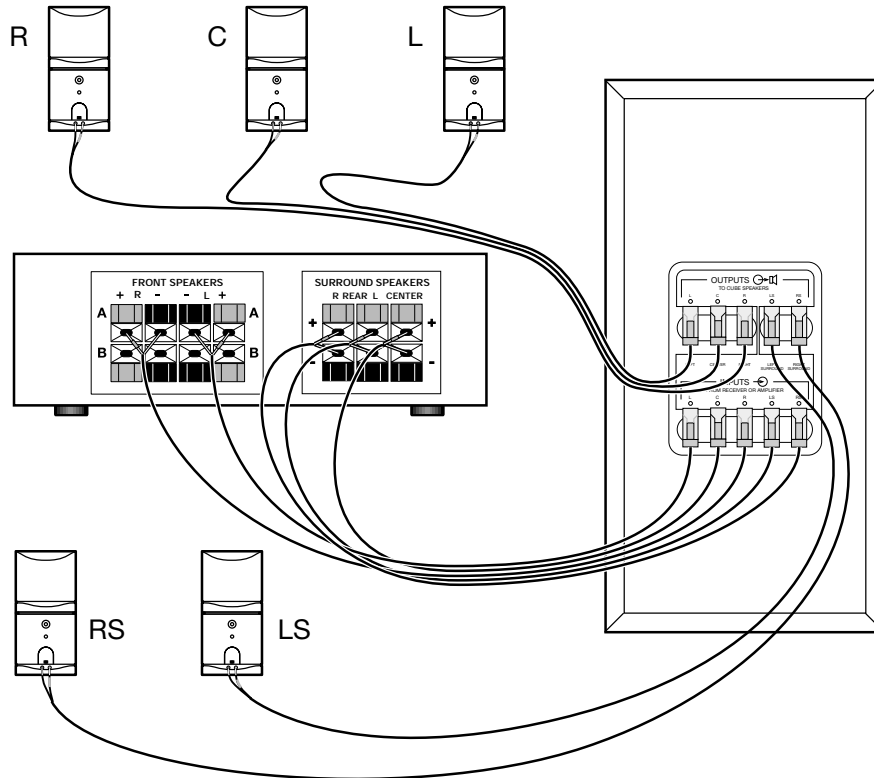

Attach the module end cover, if desired

The module end cover is designed to hide the cabling and extend the smooth, clean lines of the Acoustimass module. However, because the cover has a beveled surface, you cannot stand the module on that end with the cover in place.

If you plan to use the cover, attach it to the cable end after all connections have been checked (Figure 9). Gently push the end cover into the grommets on the Acoustimass module (Figure 10).

Your set-up is complete. Enjoy your Acoustimass 10 Series II speaker system.

Figure 10

The module end cover fits over the cables

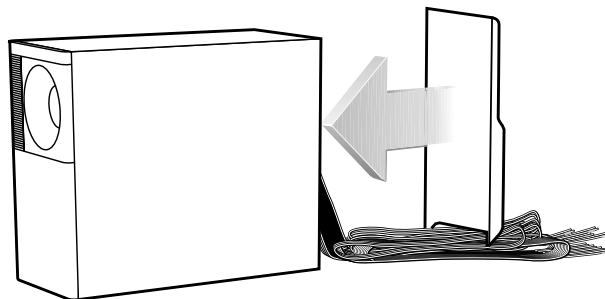

For realistic home theater sound

Each speaker produces only the sound directed to it by the steering logic in your surround-sound receiver. During a surround-sound program the front and center speakers will emit sound almost constantly, while the surround speakers may be silent for periods of time.

Setting your Dolby Pro-Logic receiver

You must set the volume levels for the front, center, and surround speakers at your receiver. You can adjust these levels at the receiver or with the remote control. Your receiver may have a *test tone* to help you set volume levels. If it does, follow these steps:

- Press *test tone* ON at the remote.
- Set the volume for the speakers in the following order: Left, Center, Right, Surround.
- Balance the pink noise tone for evenness among all individual speakers.

Instructions for this process vary, depending on the brand and model of receiver you are using. Follow your receiver owner's guide for testing and adjusting the balance of each speaker.

For use in video applications, be sure the SURROUND-SOUND *center mode* setting of your receiver is on NORMAL (Figure 11).

Figure 11

A Dolby Pro-Logic receiver set for NORMAL surround-sound

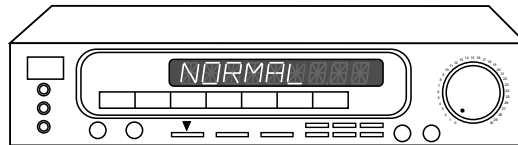

Setting your Dolby Digital (AC-3) receiver

Your Acoustimass 10 Series II speakers are compatible with the output from Dolby Digital (AC-3) receivers. Take special care to set the channel output according to the specifications listed in the chart below. The cube speakers are full-range loudspeakers and must be set up as LARGE speakers at the receiver or its TV screen menu. Turn the subwoofer OFF, but turn the LFE (low frequency effects) ON. If available, set the crossover frequency to 200Hz.

Speaker	Setting at receiver
Left and Right Front	Large
Center	Large
Left and Right Surround	Large
LFE (low frequency effects)	ON
Subwoofer	OFF
Crossover frequency	200Hz

Bass and treble adjustments

Upholstered furniture, wall-to-wall carpets, or heavy drapes can muffle treble (high notes), making your speaker system sound bass heavy. Bare floors and walls and hard surface furniture can make your speaker system sound too shrill. After listening to your speakers, you may want to adjust the balance of bass and treble. You can use the bass and treble controls on your receiver.

Troubleshooting

If you have a problem with your Acoustimass 10 Series II speakers, turn off your sound source and try the solutions below. If you still have a problem, contact your Bose® dealer to arrange for service. Or, to contact Bose directly, refer to the inside back cover of this guide.

<i>Problem</i>	<i>What to do</i>
System does not function at all	<ul style="list-style-type: none"> • Make sure the power cord of the receiver is plugged into an operating AC wall outlet and that the unit is turned on. • Be sure to select a source at the receiver (video, DVD, CD, tuner).
No sound	<ul style="list-style-type: none"> • Check the speaker connections. Turn the unit ON. • Increase the volume. • Disconnect any headphones.
Sound is distorted	<ul style="list-style-type: none"> • Make sure speaker cable is not damaged. • Reduce the volume of any external components connected to the receiver.
No bass	<ul style="list-style-type: none"> • Make sure the speaker connections at the receiver or amplifier are correct (+ to + and - to -). • If you are using Dolby Digital (AC-3) programming, verify that the settings are correct at the receiver. Be sure the source material (laserdisc, DVD, or broadcast programming) is Dolby Digital encoded.
Not enough or too much bass	<ul style="list-style-type: none"> • Move the Acoustimass module closer to a wall or corner to increase bass. Move it farther from a wall or corner to decrease bass. • Set the "Loudness" or "Bass Boost" control on your receiver to increase or decrease bass.
No surround-sound	<ul style="list-style-type: none"> • To get the full performance benefit, your HiFi Stereo VCR or stereo television must be connected to a home theater receiver. • Make sure your receiver is set to a surround-sound mode.

Customer service

For additional help in solving problems, contact Bose customer service. See the inside back cover for Bose customer service offices and phone numbers.

Cleaning the speakers

Wipe the cube speakers using a damp cloth. Do not use solvents or chemicals. Do not allow liquids to spill on or objects to drop into the Acoustimass module or the speaker grilles. You may vacuum the grilles carefully; the drivers are directly behind the grille cloth. No other maintenance is needed.

Warranty period

Bose® Acoustimass 10 Series II speakers are covered by a limited 5-year transferable warranty. Details of the coverage are explained on the warranty card packed with your speakers. Please fill out the information section on your card. The serial number is located on the Acoustimass module; you may choose to record it on page 3 of this guide. Then, please detach and mail the card to Bose in the pre-addressed envelope.

Bose will try to remedy any problem within the terms of your limited warranty.

Accessories

Floor stands: UFS-20B (black), UFS-20W (white)

Wall brackets: UB-20B (black), UB-20W (white)

Figure 12

Add-on connector for use with speaker wire



Add-on connector: PN189830 (see Figure 12)

Adapts other speaker cable for use with Acoustimass 10 Series II speakers

Extension cable (to extend length from Acoustimass module to receiver):

PN187092-1 (black), PN187092-2 (white)

20' (6 m) ribbon with five pairs of wire

Technical information

Features

- Direct/Reflecting® speaker technology
- Virtually Invisible® speaker design
- Acoustimass® speaker technology combined with Adaptive Energy Summing™ speaker design
- Magnetically shielded cube speakers
- Automatic system protection circuitry
- Syncom® computer quality control

Speaker driver complement

Cube arrays: two 2.50-inch Twiddler™ speakers

Acoustimass module: three 5.25-inch woofers for left front, center, right front, and surround channels

Connectivity

Compatible with A/V receivers rated from 10 to 200 watts per front channel and 10 to 100 watts per rear channel; rated from 4 to 8 ohms

Finish

Cube arrays: Black or Arctic white finish

Acoustimass module: Scratch-resistant black or Arctic white textured finish

Size/Weight

Cube speaker arrays: 6.2"H x 3.1"W x 4.0"D (15.7 cm x 7.8 cm x 10.2 cm)
2.4 lb (1.1 kg)

Acoustimass module: 14"H x 23"W x 7.5"D (35.5 cm x 58.5 cm x 19.0 cm)
28.7 lb (13.0 kg)

Packed system: 50.5 lb (22.9 kg)

USA

Bose Corporation, The Mountain
 Framingham, MA 01701-9168
 1-800-367-4008
 Phone hours - ET (eastern time):
 Weekdays 8:30 a.m. to 8 p.m.
 Saturdays 9 a.m. to 3 p.m.

Canada

Bose Ltd., 1-35 East Beaver Creek Road
 Richmond Hill, Ontario L4B 1B3
 1-800-465-2673
 Phone hours - ET (eastern time):
 Weekdays 9 a.m. to 5 p.m.

European Office

Bose Products B.V., Nijverheidstraat 8
 1135 GE Edam, Nederland
 TEL 0299-390111 FAX 0299-390114

Australia

Bose Pty Limited, 1 Sorrell Street
 Parramatta NSW, 2150
 TEL 02 9204-6111 FAX 02 9204-6122

Belgique/België

Bose N.V., Limesweg 2, B-3700 Tongeren
 TEL 012-390800 FAX 012-390840

Danmark

Bose A/S, Industrivej 7, 2605 Brøndby
 TEL 4343-7777 FAX 4343-7818

Deutschland

Bose GmbH, Max-Planck-Straße 36d
 D-61381 Friedrichsdorf
 TEL 06172-71040 FAX 06172-710419

France

Bose S.A., 6, rue Saint Vincent
 78100 Saint Germain en Laye
 TEL 01-30616363 FAX 01-30614105

India

Bose Corporation India Private Limited
 W-16, Greater Kailash-II
 New Delhi 110 048
 TEL (011) 648 4462 FAX (011) 648 4463

Ireland

Bose Corporation
 Carrickmacross, Co Monaghan
 TEL (042) 9661988 FAX (042) 9661998

Italia

Bose S.p.A., Via della Magliana 876
 00148 Roma
 www.bose.it
 TEL 06-65670802 FAX 06-65680167

Japan

Bose K.K., Shibuya YT Building
 28-3 Maruyama-cho
 Shibuya-ku, Tokyo 150
 TEL 3-5489-0955 FAX 3-5489-0592

Nederland

Bose B.V., Nijverheidstraat 8
 1135 GE Edam
 TEL 0299-390111 FAX 0299-390109

Norge

Bose A/S, Solheimsgate 11
 N-2001, Lillestrøm
 TEL 63-817380 FAX 63-810819

Österreich

Bose Ges.m.b.H., Vienna Business Park
 Wienerbergstrasse 7 (10.OG)
 A-1100 Vienna
 TEL 01-60404340 FAX 01-604043423

Schweiz

Bose AG, Rünenbergerstrasse 13
 4460-Gelterkinden
 TEL 061-9815544 FAX 061-9815502

Sverige

Bose A/S, Johannefredsgatan 4
 S-43153 Mölndal
 TEL 31-878850 FAX 31-274891

United Kingdom

Bose Limited
 1 Ambley Green
 Gillingham Business Park
 Gillingham, Kent ME8 ONJ
 TEL 0870-741-4500 FAX 0870-741-4545

From other locations

Bose Customer Service, 1 New York Ave.
 Framingham, MA 01701-9168 USA
 TEL (508) 766-1900 FAX (508) 766-1919

World Wide Web

www.bose.com



BOSE[®]
Better sound through research[®]

© 2000 Bose Corporation The Mountain, Framingham, MA 01701-9168 USA
194646 AM Rev. 02 JN98832