

# clarion®

**Owner's manual  
Mode d'emploi  
Manual de instrucciones**

## ***CZ309***

---

**CD/USB/MP3/WMA/AAC RECEIVER WITH CeNET CONTROL  
AUTORADIO CD/USB/MP3/WMA/AAC / AVEC COMMANDE CeNET  
RECEPTOR CD/USB/MP3/WMA/AAC CON CONTROL CeNET**

## **CLARION PRODUCT REGISTRATION INFORMATION**

For USA and Canada only  
[www.clarion.com](http://www.clarion.com)

Dear Customer:

Congratulations on your purchase of a Clarion mobile electronic products. We are confident that you'll enjoy your Clarion experience.

There are many benefits to registering your product. We invite you to visit our website at [www.clarion.com](http://www.clarion.com) to register your Clarion product.

We have made product registration simple with our easy to use website. The registration form is short and easy to complete. Once you're registered, we can keep you informed of important product information.

Register at [www.clarion.com](http://www.clarion.com) - it's easy to keep your Clarion product up to date.

## **INFORMATIONS DE L'ENREGISTREMENT DE PRODUITS CLARION**

Pour les États Unis et le Canada seulement  
[www.clarion.com](http://www.clarion.com)

Cher client:

Nous vous remercions d'avoir acheté ce produit électronique mobile Clarion. Nous sommes confiants que vous apprécierez votre expérience Clarion.

Il y a beaucoup d'avantage à enregistrer votre produits. Nous vous invitons à visiter notre site Web [www.clarion.com](http://www.clarion.com) pour enregistrer votre produit Clarion.

Nous avons facilité la tâche d'enregistrement de produit simple et facile grâce à notre site Web. Le formulaire d'enregistrement est court et facile à compléter. Lorsque vous êtes enregistrer, nous pouvons vous tenir informé des informations important de produits.

Enregistrer à [www.clarion.com](http://www.clarion.com) - c'est facile de mettre à jour votre produit Clarion.

## **INFORMACIÓN DEL REGISTRO DE PRODUCTO DE CLARION**

Para USA y Canada nomas  
[www.clarion.com](http://www.clarion.com)

Querido Cliente:

Felicitaciones por su compra de producto electrónico móvil de Clarion. Estamos seguros que usted gozará de su experiencia con el producto de Clarion.

Hay muchas ventajas al registrar su producto. Le invitamos a que visite nuestro sitio en internet [www.clarion.com](http://www.clarion.com) para registrar su producto de Clarion.

Hemos hecho el registro de producto fácil en nuestro sitio. La forma de registro es corta y fácil de completar. Una vez que lo registre, podremos proporcionarle la información de su producto.

Regístrese en [www.clarion.com](http://www.clarion.com) - es fácil mantener su producto de Clarion actualizado.

Thank you for purchasing this **Clarion** product.

\* Please read this owner's manual in its entirety before operating this equipment.

\* Check the contents of the enclosed warranty card and keep it carefully with this manual.

## Contents

<b>1. FEATURES</b> .....	<b>3</b>
<b>2. PRECAUTIONS</b> .....	<b>4</b>
<b>3. CONTROLS</b> .....	<b>5</b>
Names of the Buttons and Their Main Functions .....	5
<b>4. DCP (DETACHABLE CONTROL PANEL)</b> .....	<b>6</b>
<b>5. REMOTE CONTROL</b> .....	<b>7</b>
Functions of Remote Control Unit Buttons .....	7
Inserting the Battery .....	8
<b>6. OPERATIONS</b> .....	<b>9</b>
Basic Operations .....	9
Radio Operations .....	11
CD/MP3/WMA/AAC Operations .....	12
Operations Common to Each Mode .....	16
<b>7. ACCESSORIES</b> .....	<b>19</b>
USB/MTP Operations .....	19
iPod Operations.....	21
Satellite Radio Operations.....	23
CD Changer Operations.....	25
DVD Changer Operations .....	26
TV Operations .....	26
<b>8. TROUBLESHOOTING</b> .....	<b>27</b>
<b>9. ERROR DISPLAYS</b> .....	<b>29</b>
<b>10. SPECIFICATIONS</b> .....	<b>30</b>
<b>11. OTHERS</b> .....	<b>30</b>

## 1. FEATURES

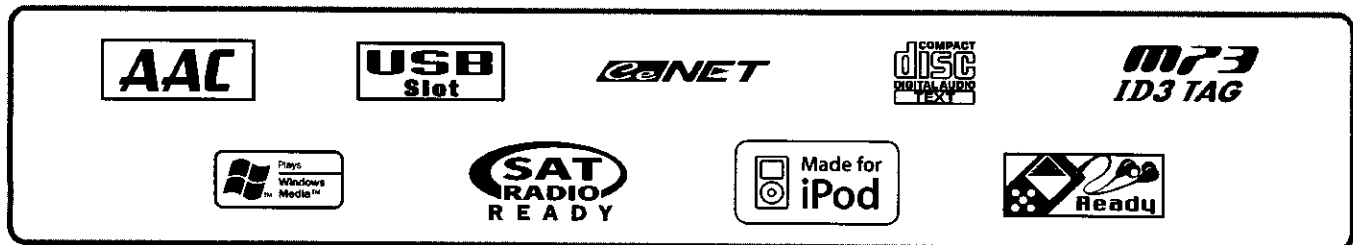

- USB Audio for iPod
- SAT Ready via CeNET
- 6ch/2V RCA Output with Built-in LPF/HPF

## 2. PRECAUTIONS

This equipment has been tested and found to comply with the limits for a Class B digital device, pursuant to Part 15 of the FCC Rules.

These limits are designed to provide reasonable protection against harmful interference in a residential installation.

This equipment generates, uses, and can radiate radio frequency energy and, if not installed and used in accordance with the instructions, may cause harmful interference to radio communications. However, there is no guarantee that interference will not occur in a particular installation.

If this equipment does cause harmful interference to radio or television reception, which can be determined by turning the equipment off and on, the user is encouraged to consult the dealer or an experienced radio/TV technician for help.

MODEL	<input type="text"/>	Clarion
<b>12V ⚡ GROUND</b>		
<b>AM 530-1710kHz / FM 87.9-107.9MHz</b>		
THIS DEVICE COMPLIES WITH PART 15 OF THE FCC RULES. OPERATION IS SUBJECT TO THE FOLLOWING TWO CONDITIONS: (1) THIS DEVICE MAY NOT CAUSE HARMFUL INTERFERENCE, AND (2) THIS DEVICE MUST ACCEPT ANY INTERFERENCE RECEIVED, INCLUDING INTERFERENCE THAT MAY CAUSE UNDESIRABLE OPERATION.		
THIS PRODUCTION COMPLIES WITH DHS RULES 21 CFR SUBCHAPTER J APPLICABLE AT DATE OF MANUFACTURE.		
CLARION CO., LTD 7-2, SHINTOSHIN, CHUO-KU, SAITAMA-SHI, SAITAMA 330-0081, JAPAN		
This product includes technology owned by Microsoft Corporation and cannot be used or distributed without a license from MSLGP.		
MANUFACTURED:		
SERIAL No. PE- <input type="text"/>		276- <input type="text"/> Clarion Co., Ltd. MADE IN <input type="text"/>

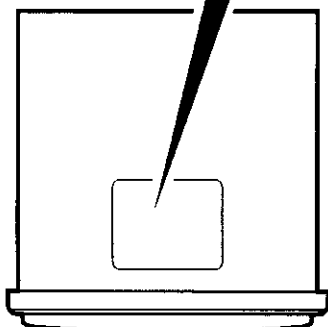

Bottom View of Source Unit

### ⚠ CAUTION

**USE OF CONTROLS, ADJUSTMENTS, OR PERFORMANCE OF PROCEDURES OTHER THAN THOSE SPECIFIED HEREIN, MAY RESULT IN HAZARDOUS RADIATION EXPOSURE.**

**THE COMPACT DISC PLAYER SHOULD NOT BE ADJUSTED OR REPAIRED BY ANYONE EXCEPT PROPERLY QUALIFIED SERVICE PERSONNEL.**

**CHANGES OR MODIFICATIONS NOT EXPRESSLY APPROVED BY THE MANUFACTURER FOR COMPLIANCE COULD VOID THE USER'S AUTHORITY TO OPERATE THE EQUIPMENT.**

#### INFORMATION FOR USERS:

**CHANGES OR MODIFICATIONS TO THIS PRODUCT NOT APPROVED BY THE MANUFACTURER WILL VOID THE WARRANTY AND WILL VIOLATE FCC APPROVAL.**

#### Handling Compact Discs

- Compared to ordinary music CDs, CD-R and CD-RW discs are both easily affected by high temperature and humidity and some of CD-R and CD-RW discs may not be played. Therefore, do not leave them for a long time in the car.
- Never stick labels on the surface of the compact disc or mark the surface with a pencil or pen.

#### Display Screen

In extreme cold, the screen movement may slow down and the screen may darken, but this is normal.

The screen will recover when it returns to normal temperature.

# 3. CONTROLS

## Names of the Buttons and Their Main Functions

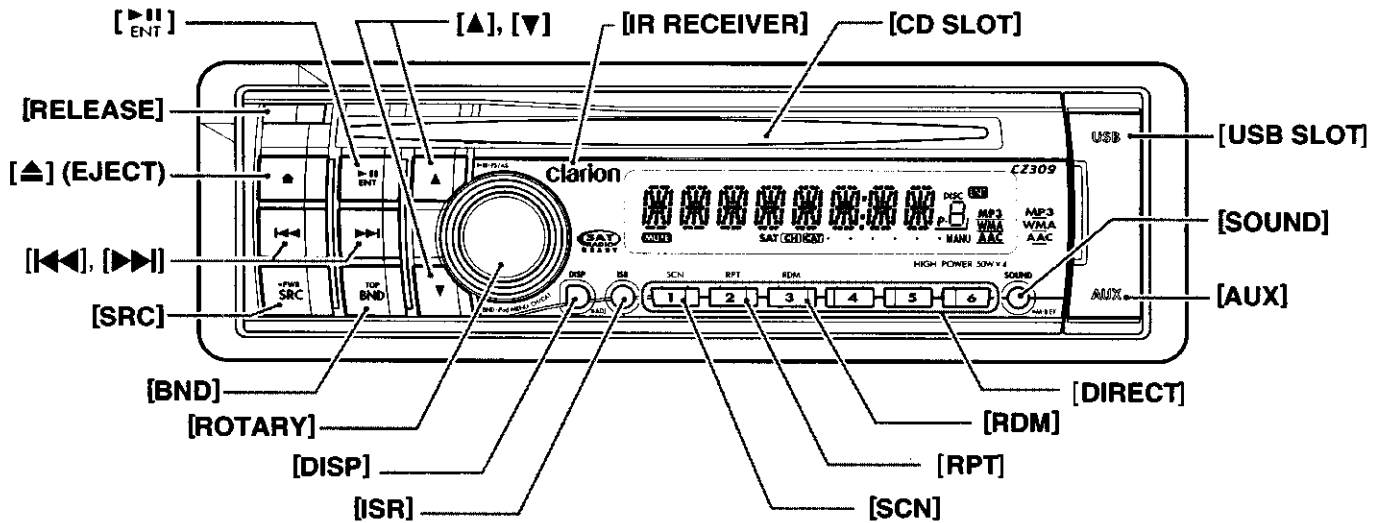

### [RELEASE] button

- Press the [RELEASE] button to unlock the DCP.

### [▶||] button

- Perform preset scan and auto store while in the radio mode.
- Play or pause a track while in the CD/MP3/WMA/AAC mode.

### [▲] (UP), [▼] (DN) buttons

- Select the folder while in the MP3/WMA/AAC mode.

### [IR RECEIVER]

- Receiver for remote control unit. (Operating range: 30° in all directions)

### [CD SLOT]

- CD insertion slot.

### [USB SLOT]

- USB memory/MTP/iPod devices insertion slot.

### [SOUND] button

- Use the button to switch to the sound adjust mode.

### [AUX] input jack

- The input jack for connecting an external device.

### [DIRECT] buttons

- Store a station into memory or recall it directly while in the radio mode.

### [RDM] button

- Perform random play while in the CD/MP3/WMA/AAC mode.

### [RPT] button

- Perform repeat play while in the CD/MP3/WMA/AAC mode.

### [SCN] button

- Perform scan play while in the CD/MP3/WMA/AAC mode.

### [ISR] button

- Recall ISR radio station in memory.
- Press and hold the button for 2 seconds or longer: Store current station into ISR memory (radio mode only).

### [DISP] button

- Switch the display indication.

### [ROTARY] knob

- Adjust the volume by turning the knob clockwise or counterclockwise.

### [BND] button

- Switch the band, or seek tuning or manual tuning while in the radio mode.
- Play a first track while in the CD/MP3/WMA/AAC mode.

### [SRC] button

- Turn on or off the power.
- Switch the operation mode among the radio mode, etc.

### [◀◀], [▶▶] buttons

- Enter the fast-forward or fast-backward mode.

### [▲] (EJECT) button

- Eject a disc when it is loaded into the unit.

# 4. DCP (DETACHABLE CONTROL PANEL)

The control panel can be detached to prevent theft. When detaching the control panel, store it in the DCP (DETACHABLE CONTROL PANEL) case to prevent scratches.

We recommend taking the DCP with you when leaving the car.

## Removing the DCP

1. Press the [SRC] button for 1 second or longer to switch off the power.
2. Press in the [RELEASE] button.

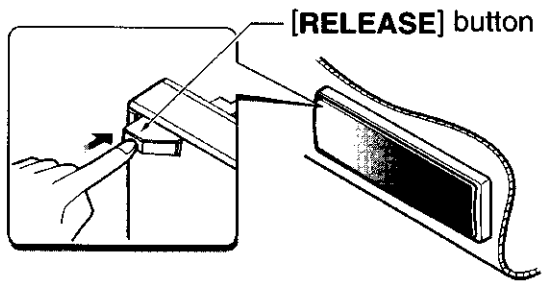

\* The DCP is unlocked

3. Remove the DCP.

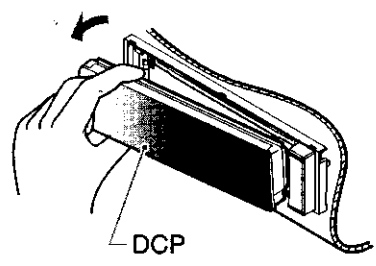

## Attaching the DCP

1. Insert the right side of the DCP into the main unit.
2. Insert the left side of the DCP into the main unit.

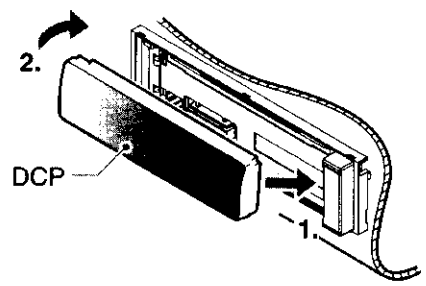

## Storing the DCP in the DCP Case

Hold the DCP, in the orientation as shown in the figure below, and put it into the supplied DCP case. (Ensure the DCP is in the correct orientation.)

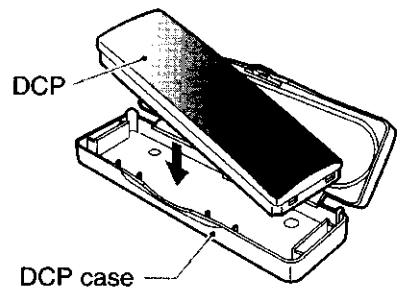

## CAUTION

- The DCP can easily be damaged by shocks. After removing it, be careful not to drop it or subject it to strong shocks.
- When the Release button is pressed and the DCP is unlocked, the car's vibrations may cause it to fall. To prevent damage to the DCP, always store it in its case after detaching it.
- The connector connecting the main unit and the DCP is an extremely important part. Be careful not to damage it by pressing on it with fingernails, pens, screwdrivers, etc.

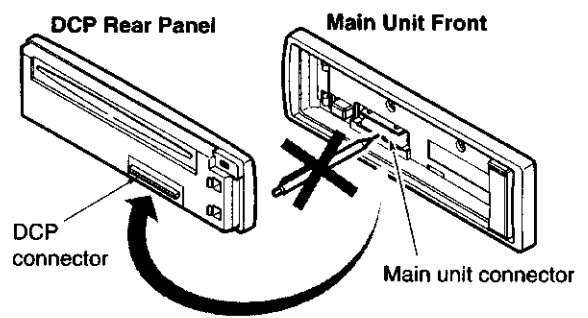

### Note:

- If the DCP is dirty, wipe off the dirt with a soft, dry cloth only.

# 5. REMOTE CONTROL

## Functions of Remote Control Unit Buttons

\* Some buttons on the remote control unit have different functions from the corresponding buttons on the main unit.

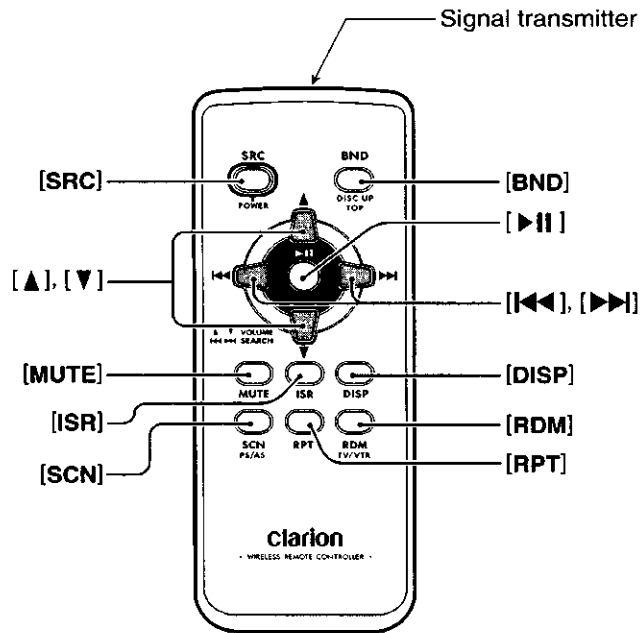

### ● Shared modes

#### [SRC] button

- Press the button to turn on the power.  
Press and hold the button for 1 second or longer to turn off the power.
- Use to alternate operation mode among the various modes.

#### [▲], [▼] buttons

- Increases and decreases volume.

#### [MUTE] button

- Turns mute function on and off.

#### [ISR] button

- Recalls ISR radio station stored in memory.
- Press and hold the button for 2 seconds or longer to store current station in ISR memory (radio mode only).

#### [DISP] button

- Press to select the desired display.

### ● Radio/Satellite Radio modes

#### [BND] button

- Switches reception band.

#### [◀◀], [▶▶] buttons

- Moves preset channels up and down.

#### [SCN] button

- Press to perform preset scan.
- Press and hold the button for 2 seconds or longer to perform auto store.
- In the Satellite Radio mode, press once to perform category scan; hold depressed for 1 second or longer to perform preset scan.

### ● CD/MP3/WMA/AAC and USB/MTP modes

#### [BND] button

- Press to play the first track.

#### [◀◀], [▶▶] buttons

- Press to move the tracks up and down.
- Press and hold the button for 1 second or longer to perform fast-forward/fast-backward (Except DRM file).

#### [▶||] button

- Switches between playback and pause.

#### [SCN] button

- Press to perform scan play.
- When in MP3/WMA/AAC and USB/MTP modes, press and hold the button for 1 second or longer to perform folder scan play.

#### [RPT] button

- Press to perform repeat play.
- When in MP3/WMA/AAC and USB/MTP modes, press and hold the button for 1 second or longer to perform folder repeat play.

#### [RDM] button

- Press to perform random play.
- When in MP3/WMA/AAC and USB/MTP modes, press and hold the button for 1 second or longer to perform folder random play.

# clarion®

**Owner's manual  
Mode d'emploi  
Manual de instrucciones**

## ***CZ309***

---

**CD/USB/MP3/WMA/AAC RECEIVER WITH CeNET CONTROL  
AUTORADIO CD/USB/MP3/WMA/AAC / AVEC COMMANDE CeNET  
RECEPTOR CD/USB/MP3/WMA/AAC CON CONTROL CeNET**



## **CLARION PRODUCT REGISTRATION INFORMATION**

For USA and Canada only  
[www.clarion.com](http://www.clarion.com)

Dear Customer:

Congratulations on your purchase of a Clarion mobile electronic products. We are confident that you'll enjoy your Clarion experience.

There are many benefits to registering your product. We invite you to visit our website at [www.clarion.com](http://www.clarion.com) to register your Clarion product.

We have made product registration simple with our easy to use website. The registration form is short and easy to complete. Once you're registered, we can keep you informed of important product information.

Register at [www.clarion.com](http://www.clarion.com) - it's easy to keep your Clarion product up to date.

## **INFORMATIONS DE L'ENREGISTREMENT DE PRODUITS CLARION**

Pour les États Unis et le Canada seulement  
[www.clarion.com](http://www.clarion.com)

Cher client:

Nous vous remercions d'avoir acheté ce produit électronique mobile Clarion. Nous sommes confiants que vous apprécierez votre expérience Clarion.

Il y a beaucoup d'avantage à enregistrer votre produits. Nous vous invitons à visiter notre site Web [www.clarion.com](http://www.clarion.com) pour enregistrer votre produit Clarion.

Nous avons facilité la tâche d'enregistrement de produit simple et facile grâce à notre site Web. Le formulaire d'enregistrement est court et facile à compléter. Lorsque vous êtes enregistrer, nous pouvons vous tenir informé des informations important de produits.

Enregistrer à [www.clarion.com](http://www.clarion.com) - c'est facile de mettre à jour votre produit Clarion.

## **INFORMACIÓN DEL REGISTRO DE PRODUCTO DE CLARION**

Para USA y Canada nomas  
[www.clarion.com](http://www.clarion.com)

Querido Cliente:

Felicitaciones por su compra de producto electrónico móvil de Clarion. Estamos seguros que usted gozará de su experiencia con el producto de Clarion.

Hay muchas ventajas al registrar su producto. Le invitamos a que visite nuestro sitio en internet [www.clarion.com](http://www.clarion.com) para registrar su producto de Clarion.

Hemos hecho el registro de producto fácil en nuestro sitio. La forma de registro es corta y fácil de completar. Una vez que lo registre, podremos proporcionarle la información de su producto.

Regístrese en [www.clarion.com](http://www.clarion.com) - es fácil mantener su producto de Clarion actualizado.

Thank you for purchasing this **Clarion** product.

- \* Please read this owner's manual in its entirety before operating this equipment.
- \* Check the contents of the enclosed warranty card and keep it carefully with this manual.

# Contents

<b>1. FEATURES</b> .....	<b>3</b>
<b>2. PRECAUTIONS</b> .....	<b>4</b>
<b>3. CONTROLS</b> .....	<b>5</b>
Names of the Buttons and Their Main Functions .....	5
<b>4. DCP (DETACHABLE CONTROL PANEL)</b> .....	<b>6</b>
<b>5. REMOTE CONTROL</b> .....	<b>7</b>
Functions of Remote Control Unit Buttons .....	7
Inserting the Battery .....	8
<b>6. OPERATIONS</b> .....	<b>9</b>
Basic Operations .....	9
Radio Operations .....	11
CD/MP3/WMA/AAC Operations .....	12
Operations Common to Each Mode .....	16
<b>7. ACCESSORIES</b> .....	<b>19</b>
USB/MTP Operations .....	19
iPod Operations.....	21
Satellite Radio Operations.....	23
CD Changer Operations.....	25
DVD Changer Operations .....	26
TV Operations .....	26
<b>8. TROUBLESHOOTING</b> .....	<b>27</b>
<b>9. ERROR DISPLAYS</b> .....	<b>29</b>
<b>10. SPECIFICATIONS</b> .....	<b>30</b>
<b>11. OTHERS</b> .....	<b>30</b>

# 1. FEATURES

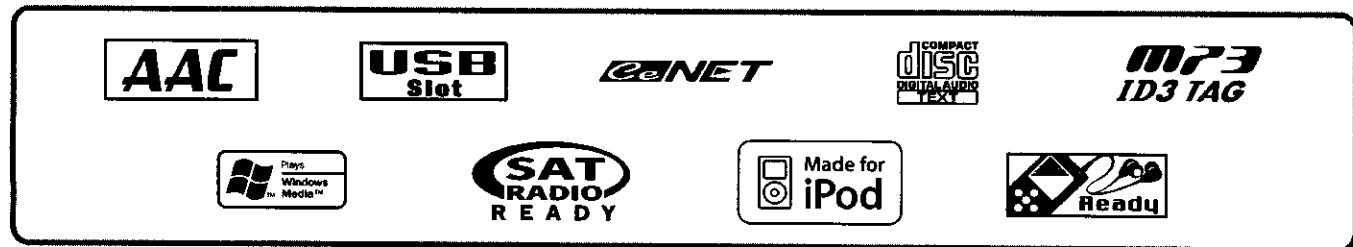

- USB Audio for iPod
- SAT Ready via CeNET
- 6ch/2V RCA Output with Built-in LPF/HPF

## 2. PRECAUTIONS

This equipment has been tested and found to comply with the limits for a Class B digital device, pursuant to Part 15 of the FCC Rules.

These limits are designed to provide reasonable protection against harmful interference in a residential installation.

This equipment generates, uses, and can radiate radio frequency energy and, if not installed and used in accordance with the instructions, may cause harmful interference to radio communications. However, there is no guarantee that interference will not occur in a particular installation.

If this equipment does cause harmful interference to radio or television reception, which can be determined by turning the equipment off and on, the user is encouraged to consult the dealer or an experienced radio/TV technician for help.

MODEL	<input type="text"/>	clarion
<b>12V ⚡ GROUND</b>		
<b>AM 530-1710kHz / FM 87.9-107.9MHz</b>		
THIS DEVICE COMPLIES WITH PART 15 OF THE FCC RULES. OPERATION IS SUBJECT TO THE FOLLOWING TWO CONDITIONS: (1) THIS DEVICE MAY NOT CAUSE HARMFUL INTERFERENCE, AND (2) THIS DEVICE MUST ACCEPT ANY INTERFERENCE RECEIVED, INCLUDING INTERFERENCE THAT MAY CAUSE UNDESIRE OPERATION.		
THIS PRODUCTION COMPLIES WITH DHHS RULES 21 CFR SUBCHAPTER J APPLICABLE AT DATE OF MANUFACTURE.		
CLARION CO., LTD 7-2, SHINTOSHIN, CHUO-KU, SAITAMA-SHI, SAITAMA 330-0081, JAPAN		
This product includes technology owned by Microsoft Corporation and cannot be used or distributed without a license from MSLGP.		
MANUFACTURED:		
SERIAL No. PE- <input type="text"/>		276- <input type="text"/> Clarion Co., Ltd. MADE IN <input type="text"/>

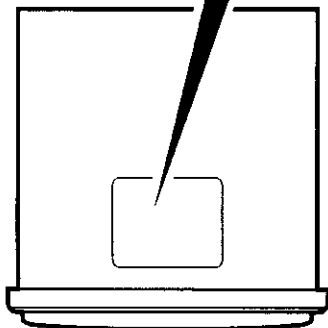

Bottom View of Source Unit

### ⚠ CAUTION

**USE OF CONTROLS, ADJUSTMENTS, OR PERFORMANCE OF PROCEDURES OTHER THAN THOSE SPECIFIED HEREIN, MAY RESULT IN HAZARDOUS RADIATION EXPOSURE.**

**THE COMPACT DISC PLAYER SHOULD NOT BE ADJUSTED OR REPAIRED BY ANYONE EXCEPT PROPERLY QUALIFIED SERVICE PERSONNEL.**

**CHANGES OR MODIFICATIONS NOT EXPRESSLY APPROVED BY THE MANUFACTURER FOR COMPLIANCE COULD VOID THE USER'S AUTHORITY TO OPERATE THE EQUIPMENT.**

#### **INFORMATION FOR USERS:**

**CHANGES OR MODIFICATIONS TO THIS PRODUCT NOT APPROVED BY THE MANUFACTURER WILL VOID THE WARRANTY AND WILL VIOLATE FCC APPROVAL.**

#### **Handling Compact Discs**

- Compared to ordinary music CDs, CD-R and CD-RW discs are both easily affected by high temperature and humidity and some of CD-R and CD-RW discs may not be played. Therefore, do not leave them for a long time in the car.
- Never stick labels on the surface of the compact disc or mark the surface with a pencil or pen.

#### **Display Screen**

In extreme cold, the screen movement may slow down and the screen may darken, but this is normal.

The screen will recover when it returns to normal temperature.

# 3. CONTROLS

## Names of the Buttons and Their Main Functions

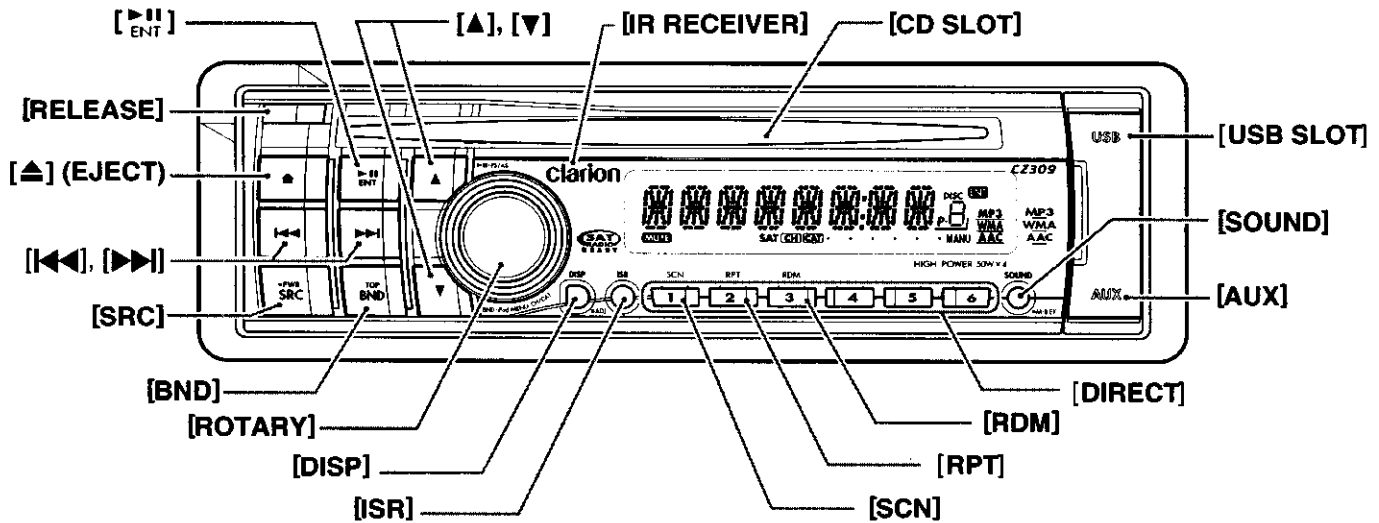

### [RELEASE] button

- Press the [RELEASE] button to unlock the DCP.

### [▶||] button

- Perform preset scan and auto store while in the radio mode.
- Play or pause a track while in the CD/MP3/WMA/AAC mode.

### [▲] (UP), [▼] (DN) buttons

- Select the folder while in the MP3/WMA/AAC mode.

### [IR RECEIVER]

- Receiver for remote control unit. (Operating range: 30° in all directions)

### [CD SLOT]

- CD insertion slot.

### [USB SLOT]

- USB memory/MTP/iPod devices insertion slot.

### [SOUND] button

- Use the button to switch to the sound adjust mode.

### [AUX] input jack

- The input jack for connecting an external device.

### [DIRECT] buttons

- Store a station into memory or recall it directly while in the radio mode.

### [RDM] button

- Perform random play while in the CD/MP3/WMA/AAC mode.

### [RPT] button

- Perform repeat play while in the CD/MP3/WMA/AAC mode.

### [SCN] button

- Perform scan play while in the CD/MP3/WMA/AAC mode.

### [ISR] button

- Recall ISR radio station in memory.
- Press and hold the button for 2 seconds or longer: Store current station into ISR memory (radio mode only).

### [DISP] button

- Switch the display indication.

### [ROTARY] knob

- Adjust the volume by turning the knob clockwise or counterclockwise.

### [BND] button

- Switch the band, or seek tuning or manual tuning while in the radio mode.
- Play a first track while in the CD/MP3/WMA/AAC mode.

### [SRC] button

- Turn on or off the power.
- Switch the operation mode among the radio mode, etc.

### [◀◀], [▶▶] buttons

- Enter the fast-forward or fast-backward mode.

### [▲] (EJECT) button

- Eject a disc when it is loaded into the unit.

# 4. DCP (DETACHABLE CONTROL PANEL)

The control panel can be detached to prevent theft. When detaching the control panel, store it in the DCP (DETACHABLE CONTROL PANEL) case to prevent scratches.

We recommend taking the DCP with you when leaving the car.

## Removing the DCP

1. Press the [SRC] button for 1 second or longer to switch off the power.
2. Press in the [RELEASE] button.

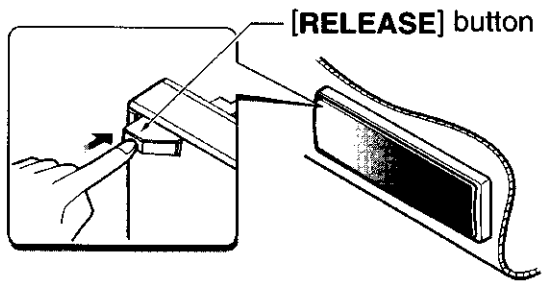

\* The DCP is unlocked

3. Remove the DCP.

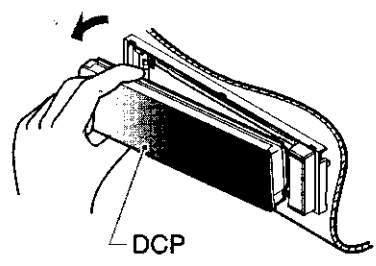

## Attaching the DCP

1. Insert the right side of the DCP into the main unit.
2. Insert the left side of the DCP into the main unit.

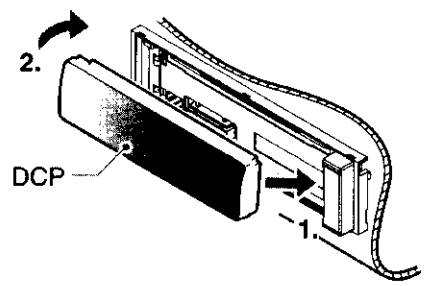

## Storing the DCP in the DCP Case

Hold the DCP, in the orientation as shown in the figure below, and put it into the supplied DCP case. (Ensure the DCP is in the correct orientation.)

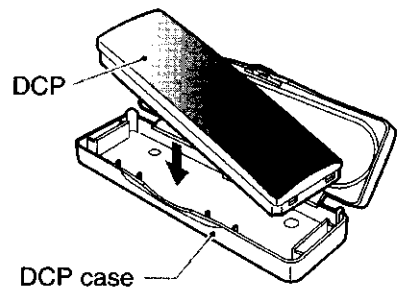

## CAUTION

- The DCP can easily be damaged by shocks. After removing it, be careful not to drop it or subject it to strong shocks.
- When the Release button is pressed and the DCP is unlocked, the car's vibrations may cause it to fall. To prevent damage to the DCP, always store it in its case after detaching it.
- The connector connecting the main unit and the DCP is an extremely important part. Be careful not to damage it by pressing on it with fingernails, pens, screwdrivers, etc.

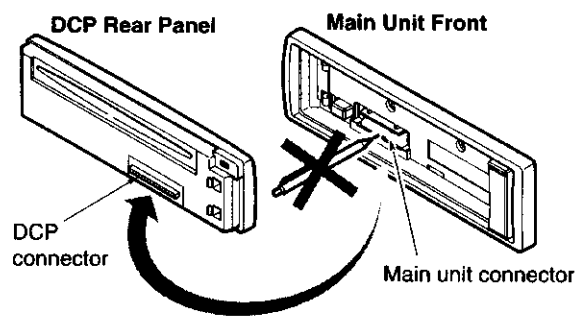

### Note:

- If the DCP is dirty, wipe off the dirt with a soft, dry cloth only.

# 5. REMOTE CONTROL

## Functions of Remote Control Unit Buttons

\* Some buttons on the remote control unit have different functions from the corresponding buttons on the main unit.

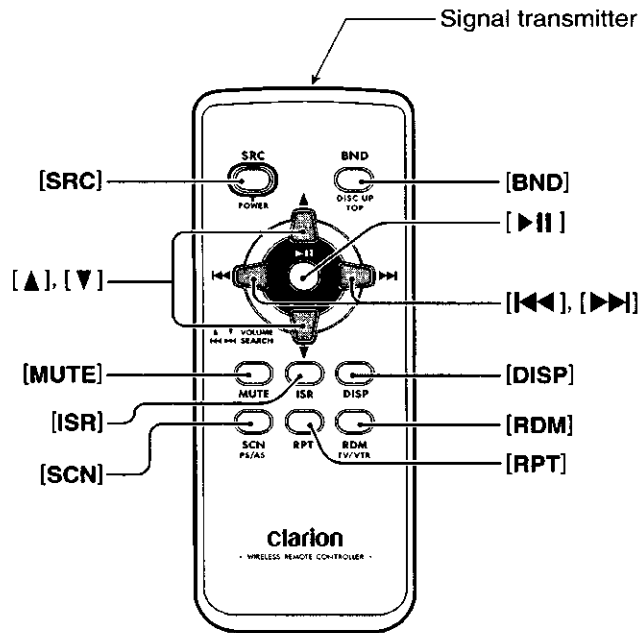

### ● Shared modes

#### [SRC] button

- Press the button to turn on the power.  
Press and hold the button for 1 second or longer to turn off the power.
- Use to alternate operation mode among the various modes.

#### [▲], [▼] buttons

- Increases and decreases volume.

#### [MUTE] button

- Turns mute function on and off.

#### [ISR] button

- Recalls ISR radio station stored in memory.
- Press and hold the button for 2 seconds or longer to store current station in ISR memory (radio mode only).

#### [DISP] button

- Press to select the desired display.

### ● Radio/Satellite Radio modes

#### [BND] button

- Switches reception band.

#### [◀◀], [▶▶] buttons

- Moves preset channels up and down.

#### [SCN] button

- Press to perform preset scan.
- Press and hold the button for 2 seconds or longer to perform auto store.
- In the Satellite Radio mode, press once to perform category scan; hold depressed for 1 second or longer to perform preset scan.

### ● CD/MP3/WMA/AAC and USB/MTP modes

#### [BND] button

- Press to play the first track.

#### [◀◀], [▶▶] buttons

- Press to move the tracks up and down.
- Press and hold the button for 1 second or longer to perform fast-forward/fast-backward (Except DRM file).

#### [▶||] button

- Switches between playback and pause.

#### [SCN] button

- Press to perform scan play.
- When in MP3/WMA/AAC and USB/MTP modes, press and hold the button for 1 second or longer to perform folder scan play.

#### [RPT] button

- Press to perform repeat play.
- When in MP3/WMA/AAC and USB/MTP modes, press and hold the button for 1 second or longer to perform folder repeat play.

#### [RDM] button

- Press to perform random play.
- When in MP3/WMA/AAC and USB/MTP modes, press and hold the button for 1 second or longer to perform folder random play.

## Functions of Remote Control Unit Buttons

### ● CD changer/DVD changer modes

#### [BND] button

- Press to switch to next disc in ascending order.

#### [◀◀], [▶▶] buttons

- Press to move the tracks up and down.
- Press and hold the button for 1 second or longer to perform fast-forward/fast-backward.

#### [▶||] button

- Switches between playback and pause.

#### [SCN] button

- Press to perform scan play.
- Press and hold the button for 1 second or longer to perform disc scan play.

#### [RPT] button

- Press to perform repeat play.
- Press and hold the button for 1 second or longer to perform disc repeat play.

#### [RDM] button

- Press to perform random play.
- Press and hold the button for 1 second or longer to perform disc random play.

### ● iPod mode

#### [◀◀], [▶▶] buttons

- Press to move the tracks up and down.
- Press and hold the button for 1 second or longer to perform fast-forward/fast-backward.

#### [▶||] button

- Switches between playback and pause.

#### [RPT] button

- Press to perform repeat play.

#### [RDM] button

- Press to perform random play.
- Press and hold the button for 1 second or longer to perform all random play.

### ● TV mode

#### [BND] button

- Switches reception band.

#### [◀◀], [▶▶] buttons

- Moves preset channels up and down.

#### [SCN] button

- Press to perform preset scan.
- Press and hold the button for 2 seconds or longer to perform auto store.

#### [RDM] button

- Press to alternate between TV and VTR.

## Inserting the Battery

- ① Turn over the remote control unit and slide the cover in the direction indicated by the arrow in the illustration.
- ② Insert the battery (CR2025) into the insertion guides, with the printed side (+) facing upwards.
- ③ Press the battery in the direction indicated by the arrow so that it slides into the compartment.
- ④ Replace the cover and slide in until it clicks into place.

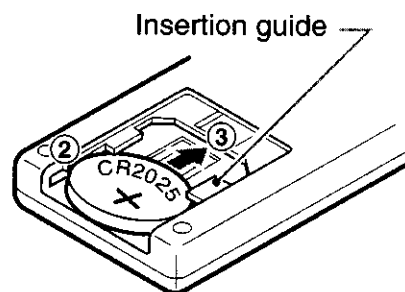
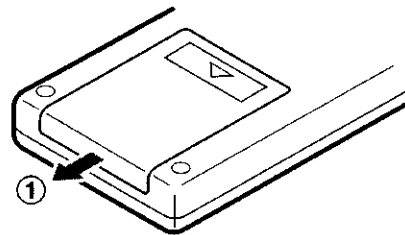

### Notes:

Misuse may result in rupture of the battery, producing leakage of fluid and resulting in personal injury or damage to surrounding materials. Always follow these safety precautions:

- Use only the designated battery.
- When replacing the battery, insert properly, with +/- polarities oriented correctly.
- Do not subject battery to heat, or dispose of in fire or water. Do not attempt to disassemble the battery.
- Dispose of used batteries properly.

# 6. OPERATIONS

## Note:

- Be sure to read this chapter referring to the front diagrams of chapter "3. CONTROLS" on page 5.

## Basic Operations

### ⚠ CAUTION

Be sure to lower the volume before switching off the unit power or the ignition key. The unit remembers its last volume setting.

### Turning on/off the power

1. Press the [SRC] button to turn on the power.
2. Press and hold the [SRC] button for 1 second or longer to turn off the power for the unit.

## Note:

- **System check**  
The first time this unit is turned on after the wire connections are completed, it must be checked what equipment is connected. When the power is turned on, the "S-CHECK" appears in the display, then the unit returns to the clock display mode. The system check starts within the unit. Then press the [SRC] button again, the unit turn to the radio mode.

### Selecting a mode

1. Press the [SRC] button to change the operation mode.
2. Each time you press the [SRC] button, the operation mode changes in the following order:  
Radio → (Satellite radio) → CD/MP3/WMA/AAC → USB/MTP/iPod → (CD changer) → (DVD changer) → (TV) → AUX → Radio...
  - \* External equipment not connected with CeNET is not displayed.
  - \* iPod/MTP can connect to this unit via USB SLOT.

### Adjusting the volume

1. Turning the [ROTARY] knob clockwise increases the volume; turning it counterclockwise decreases the volume.
  - \* The volume level is from 0 (minimum) to 33 (maximum).

### Switching the display

Press the [DISP] button to select the desired display.

## Sound Adjustment

You can adjust a sound effect or tone quality to your preference.

### To change sound setting

1. Press the [SOUND] button to switch to the sound adjustment selection display.
  - \* The factory default sound setting is "Z-EHCR".
2. Then press the [◀◀] or [▶▶] button to select the sound adjustment mode.  
Each time you press the [◀◀] or [▶▶] button, the sound adjustment mode changes as following order:  
"Z-EHCR" ↔ "BASS" ↔ "TREBLE" ↔ "BALANCE" ↔ "FADER" ↔ "S-W LPF" ↔ "S-W VOL" ↔ "HPF"
  - \* In the case of display blinking "ENT", you can press the [ENT] button to adjust the setting value.
  - \* The sound adjustment mode will be displayed for 2 seconds before showing the sound setting.
3. Press the [▲] or [▼] button to adjust the selected audio mode.
4. After completing settings, press the [SOUND] button to return to the previous mode.

### ● Setting the Z-Enhancer Plus

This unit is provided with 4 types of sound tone effects stored in memory.

Select the one you prefer.

- \* The factory default setting is "OFF".

- 2-1. Select "Z-EHCR".



## Basic Operations

- 3-1. Each time you press the [▲] or [▼] button, the tone effect changes in the following order:

“Z+FLAT” ↔ “CUSTOM” ↔ “EXCITE” ↔ “IMPACT” ↔ “B-BOOST” ↔ “OFF”

**Z+FLAT** : user Z+FLAT

**CUSTOM** : user custom

**EXCITE** : bass and treble emphasized  
mid emphasized

**IMPACT** : bass and treble emphasized

**B-BOOST** : bass emphasized

**OFF** : no sound effect

### When “Z+FLAT” is set:

- 3-2. Press and hold the [ENT] button for 1 second or longer, bass/treble characteristics become flat and switch to the “CUSTOM” mode.

### When “CUSTOM” is set:

- 3-1. Press the [◀◀] or [▶▶] button to select the “BASS” or “TREBLE” mode to adjust.

### When “EXCITE/IMPACT/B-BOOST” is set:

- 3-2. Press the [ENT] button.  
3-3. Press the [▲] or [▼] button to adjust the setting in the range of -3 to +3.  
\* The factory default setting is “0”.  
3-4. Press the [ENT] button to return to the previous mode.

### ● Adjusting the bass

This adjustment can be performed only when the Z-Enhancer Plus is set to “CUSTOM”.

- 2-1. Select “BASS”.
- 3-1. Press the [▲] or [▼] button to select as following order.  
“BASS<G>” ↔ “BASS<F>” ↔ “BASS<Q>”  
\* The factory default setting is “BASS<G>”.
- 3-2. Press the [ENT] button.
- 3-3. Press the [▲] or [▼] button to adjust the gain, the F (center frequency) and the Q.
- BASS<G>**  
: The factory default setting is “0”.  
(Adjustment range: +7 to -7)
- BASS<F>**  
: The factory default setting is “60”.  
(Adjustment range: 60/80/100/200)
- BASS<Q>**  
: The factory default setting is “1”.  
(Adjustment range: 1/1.25/1.5/2)

- 3-4. Press the [ENT] button to return to the previous mode.

### ● Adjusting the treble

This adjustment can be performed only when the Z-Enhancer Plus is set to “CUSTOM”.

- 2-1. Select “TREBLE”.
- 3-1. Press the [▲] or [▼] button to select as following order.  
“TREB<G>” ↔ “TREB<F>”  
\* The factory default setting is “TREB<G>”.
- 3-2. Press the [ENT] button.
- 3-3. Press the [▲] or [▼] button to adjust the gain, the F (center frequency) and the Q.  
**TREB<G>**: The factory default setting is “0”.  
(Adjustment range: +7 to -7)  
**TREB<F>**: The factory default setting is “10k”.  
(Adjustment range:  
10k/12.5k/15k/17.5k)
- 3-4. Press the [ENT] button to return to the previous mode.

### ● Adjusting the balance

- 2-1. Select “BALANCE”.
- 3-1. Press the [▲] or [▼] button to adjust the balance of the right and left speakers.  
\* The factory default setting is “CENTER” (center). (Adjustment range: RIGHT12 to LEFT12 (right 12 to left 12))

### ● Adjusting the fader

- 2-1. Select “FADER”.
- 3-1. Press the [▲] or [▼] button to adjust the balance of the rear and front speakers.  
\* The factory default setting is “CENTER” (center). (Adjustment range: FRONT12 to REAR12 (front 12 to rear 12))

### ● Setting the subwoofer

You can set the low pass filter of subwoofer.

- 2-1. Select “S-W LPF”.
- 3-1. Each time press the [▲] or [▼] button to select the setting, the setting changes in the following order:  
“THROUGH” ↔ “LPF 50” ↔ “LPF 80” ↔ “LPF 120”  
\* The factory default setting is “THROUGH”.

## Basic Operations

### ● Adjusting the subwoofer output volume

You can adjust the volume output from the unit's subwoofer output terminal.

This adjustment can be performed only when the "S-W LPF" is set to "LPF 120", "LPF 80" or "LPF 50".

2-1. Select "S-W VOL".

3-1. Press the [▲] or [▼] button to increase or decrease the subwoofer volume.

- \* The factory default setting is "0".  
(Adjustment range: +6 to -6)
- \* When the volume level is more than 30, the subwoofer volume adjustment value can not reach +6.

### ● Adjusting the high pass filter

2-1. Select "HPF".

3-1. Each time you press the [▲] or [▼] button to select the setting.

The setting changes in the following order:  
"120" ↔ "THROUGH"

- \* The factory default setting is "THROUGH" (through).
- \* This is supported only with amplifiers equipped with this function. Output is not supported from RCA cables.

#### Note:

- During SOUND adjustment mode, if no operation is performed for more than 10 seconds, this mode can be cancelled and return to previous mode.

### Setting the MAGNA BASS EXTEND

The MAGNA BASS EXTEND does not adjust the low frequencies like the normal sound adjustment function, but emphasizes the deep bass frequencies to provide you with a dynamic sound.

- \* The factory default setting is "OFF" (off).
1. Press and hold the [SOUND] button for 1 second or longer to turn on the MAGNA BASS EXTEND effect. "M-B EX" appears in the display for 2 seconds.
  2. Press and hold the [SOUND] button for 1 second or longer to turn off the MAGNA BASS EXTEND effect.

## Radio Operations

### Listening to the radio

1. Press the [SRC] button and select the radio mode.
2. Press the [BND] button and select the radio band. Each time the button is pressed, the radio reception band changes in the following order:  
F1 (FM1) → F2 (FM2) → F3 (FM3) → AM → F1 (FM1)...

### Tuning

There are 3 types of tuning mode available, seek tuning, manual tuning and preset tuning.

#### Seek tuning

1. Press the [BND] button and select the desired band (FM or AM).
  - \* If "MANU" is lit in the display, press and hold the [BND] button for 1 second or longer. "MANU" in the display goes off and seek tuning is now available.
2. Press the [◀◀] or [▶▶] button to automatically seek a station.

#### Manual tuning

There are 2 ways available: Quick tuning and step tuning.

##### ● Quick tuning

Press and hold the [◀◀] or [▶▶] button for 1 second or longer to tune in a station.

##### ● Step tuning

Press the [◀◀] or [▶▶] button to manually tune in a station.

#### Recalling a preset station

A total of 24 preset positions (6-FM1, 6-FM2, 6-FM3, 6-AM) exists to store individual radio stations in memory. Press the corresponding [DIRECT] button or the [▲] / [▼] button to recall the stored radio frequency automatically.

#### Manual memory

1. Select the desired station with seek tuning or manual tuning.

## Radio Operations

2. Press and hold one of the [DIRECT] buttons for 2 seconds or longer to store the current station into preset memory.

### Auto store

Auto store is a function for storing up to 6 stations that are automatically tuned in sequentially. If 6 receivable stations cannot be received, a previously stored station remains unoverwritten at the memory position.

1. Press the [BND] button and select the desired band (FM or AM).
2. Press and hold the [▶] button for 2 seconds or longer. The stations with good reception are stored automatically to the preset channels.

### Preset scan

Preset scan receives the stations stored in preset memory in order. This function is useful when searching for a desired station in memory.

1. Press the [▶] button.
2. When a desired station is tuned in, press the [▶] button again to continue receiving that station.

#### Note:

- Be careful not to press and hold the [▶] button for 2 seconds or longer, otherwise the auto store function is engaged and the unit starts storing stations.

### Instant station recall (ISR)

Instant station recall is a special radio preset that instantly accesses a favorite radio station at a touch of a button. The ISR function even operates with the unit in other modes.

#### ● ISR memory

1. Select the station that you wish to store in ISR memory.
2. Press and hold the [ISR] button for 2 seconds or longer.

#### ● Recalling a station with ISR

In any mode, press the [ISR] button to turn on the radio function and tune the selected radio station. "ISR" appears in the display. Press the [ISR] button again to return to the previous mode.

## CD/MP3/WMA/AAC Operations

### MP3/WMA/AAC

This unit can play back MP3/WMA/AAC files.

#### Notes:

- If you play a file with DRM (Digital Rights Management) for WMA remaining ON, no audio is output (The WMA indicator blinks).
- Windows Media™, and the Windows® logo are trademarks, or registered trademarks of Microsoft Corporation in the United States and/or other countries.

#### ● To disable DRM (Digital Rights Management)

1. When using Windows Media Player 9/10/11, click on TOOL → OPTIONS → MUSIC RECORD tab, then under Recording settings, unclick the Check box for RECORD PROTECTED MUSIC. Then, reconstruct files.

Personally constructed WMA files are used at your own responsibility.

### Precautions when creating MP3/WMA/AAC file

#### ● Usable sampling rates and bit rates

1. MP3: Sampling rate 8 kHz-48 kHz,  
Bit rate 8 kbps-320 kbps / VBR
2. WMA: Bit rate 8 kbps-320 kbps
3. AAC: Sampling rate 8 kHz-48 kHz,  
Bit rate 8 kbps-320 kbps / VBR

#### ● File extensions

1. Always add a file extension ".MP3", ".WMA" or ".M4A" to MP3, WMA or AAC file by using single byte letters. If you add a file extension other than specified or forget to add the file extension, the file cannot be played.
2. Files without MP3/WMA/AAC data will not play. The indication "NO FILE" appears in the play time display if you attempt to play files without MP3/WMA/AAC data.

\* When VBR files are played, the play time display may differ the play location.

\* When MP3/WMA/AAC files are played, a little no sound part is caused between tunes.

## ● Logical format (File system)

1. When writing MP3/WMA/AAC file on a CD-R disc or CD-RW disc, please select "ISO9660 level 1, 2 or JOLIET or Romeo" or APPLE ISO as the writing software format. Normal play may not be possible if the disc is recorded on another format.
2. The folder name and file name can be displayed as the title during MP3/WMA/AAC play but the title must be within 64 single byte alphabetical letters and numerals (including an extension).
3. Do not affix a name to a file inside a folder having the same name.

## ● Folder structure

1. A disc with a folder having more than 8 hierarchical levels will be impossible.

## ● Number of files or folders

1. Up to 255 files can be recognized per folder. Up to 510 files can be played.
2. Tracks are played in the order that they were recorded onto a disc. (Tracks might not always be played in the order displayed on the PC.)
3. Some noise may occur depending on the type of encoder software used while recording.

## Set the type of file to be played (multi-session function)

When a single disc holds both normal CD type tracks and MP3/WMA/AAC type tracks, use this command to select which type of track to play.

- \* Default setting is "M-SESS CD".
- When only one type of track (either music CD or MP3/WMA/AAC) is recorded on a disc, selecting either type will allow playback of the disc.
- When playing CCCD (copy-control CDs), set to CD type.

1. Press and hold the [BND] button for 1 second or longer.

Each time the button is held pressed in this way, "M-SESS" will be displayed for 1 second, then "CD" or "MP3" appears in the display, the playback type alternates between CD type and MP3/WMA/AAC type.

- "M-SESS CD"

When playing music CD only.

- "M-SESS MP3"

When playing music MP3/WMA/AAC only.

2. When setting is completed, remove the disc and reinsert it.

## Disc-In-Play function

As long as the ignition key is turned to the ON or ACC position, this function allows you to turn the power to the unit and start playing the disc automatically when the disc is inserted even if the power is not turned on.

### ▲ CAUTION

- Do not try to put your hand or fingers in the disc insertion slot. Also never insert foreign objects into the slot.
- Do not insert discs where adhesive comes out from cellophane tape or a rental CD label, or discs with marks where cellophane tape or rental CD labels were removed. It may be impossible to extract these discs from the unit and they may cause the unit to break down.

## Backup Eject function

Just pressing the [▲] button, ejects the disc even if the power to the unit was not turned on.

1. Press the [▲] button to eject the CD. Take it out from the ejected position. "EJECT" appears in the display.

### Notes:

- If a CD (12 cm) is left in the ejected position for 15 seconds, the CD is automatically reloaded (Auto reload).
- If you force a CD into before auto reloading, this can damage the CD.

**Listening to a disc already loaded in the unit**

Press the [SRC] button to select the CD/MP3/WMA/AAC mode.



When the unit enters the CD/MP3/WMA/AAC mode, play starts automatically.

If there is no disc loaded, the indication “**NO DISC**” appears in the title display.

**Loading a CD**

1. Insert a CD into the center of the CD SLOT with the labeled side facing up. “**LOADING**” appears in the display, the CD enters into the slot, and the play starts.

**Notes:**

- Never insert foreign objects into the CD SLOT.
- If the CD is not inserted easily, there may be another CD in the mechanism or the unit may require service.
- Discs not bearing the  or  mark and CD-ROMs cannot be played by this unit.
- Some CDs recorded in CD-R/CD-RW mode may not be usable.

**Pausing play**

1. Press the [▶||] button to pause play. “**PAUSE**” appears in the display.
2. To resume CD play, press the [▶||] button again.

**Displaying CD titles**

This unit can display title data for CD-text/MP3/WMA/AAC disc and user titles input with this unit.

1. Each time you press the [DISP] button to change the title display.

**● CD-TEXT disc**

User → Track → Disc → Artist → User ...

**● MP3/WMA/AAC disc**

Track → Folder → Title → Album → Artist → Track ...

**Notes:**

- If the CD playing is not a CD-text CD or no user title has been input, “**NO TITLE**” appears in the display.
- If MP3/WMA/AAC disc is not input TAG, “**NO TITLE**” appears in the display.
- For MP3, supports ID3 Tags V2.3 / 2.2 / 1.1 / 1.0.
- Tag displays give priority to V2.3 / 2.2.
- In the case of album Tags for WMA, the information written into the extension header is displayed.
- Only ASCII characters can be displayed in Tags.

**Selecting a track****● Track-up**

1. Press the [▶▶] button to move ahead to the beginning of the next track.
2. Each time you press the [▶▶] button, the track advances ahead to the beginning of the next track.

**● Track-down**

1. Press the [◀◀] button to move back to the beginning of the current track.
2. Press the [◀◀] button twice to move back to the beginning of the previous track.

**Fast-forward/fast-backward****● Fast-forward**

1. Press and hold the [▶▶] button for 1 second or longer.

**● Fast-backward**

1. Press and hold the [◀◀] button for 1 second or longer.

\* For MP3/WMA/AAC discs, it takes some time until the start of searching and between tracks. In addition, the playing time may have a margin of error.

## Folder Select

This function allows you to select a folder containing MP3/WMA/AAC files and start playing from the first track in the folder.

1. Press the [▼] or [▲] button.  
Press the [▲] button to move the next folder.  
Press the [▼] button to move the previous folder.
2. To select a track, press the [◀◀] or [▶▶] button.

## Top function

The top function resets the CD player to the first track of the disc. Press the [BND] button to play the first track (track No. 1) on the disc.

\* In case of MP3/WMA/AAC, the first track of a folder being played will be returned.

## Other various play functions

### ● Scan play

This function allows you to locate and play the first 10 seconds of all the tracks recorded on a disc.

1. Press the [SCN] button to perform scan play.

### ● Folder scan play

This function allows you to locate and play the first 10 seconds of the first track of all the folders on an MP3/WMA/AAC disc.

1. Press and hold the [SCN] button for 1 second or longer to perform folder scan play.

### ● Repeat play

This function allows you to play the current track repeatedly.

1. Press the [RPT] button to perform repeat play.

### ● Folder repeat play

This function allows you to play a track currently being played in the MP3/WMA/AAC folder repeatedly.

1. Press and hold the [RPT] button for 1 second or longer to perform folder repeat play.

### ● Random play

This function allows you to play all tracks recorded on a disc in a random order.

1. Press the [RDM] button to perform random play.

### ● Folder random play

This function allows you to play all the tracks of all the folders recorded on an MP3/WMA/AAC disc in a random order.

1. Press and hold the [RDM] button for 1 second or longer to perform folder random play.

### ● To cancel play

1. Press the operating button previously selected.

\* The various play mode is canceled and the various play off mode appears in the display for 2 seconds.

# Operations Common to Each Mode

## To change adjustment setting

1. Press and hold the [DISP] button for 1 second or longer to switch to the adjustment selection display.
2. Press the [◀◀] or [▶▶] button to select the "item name".  
 "CLOCK" ↔ "SETTINGS" ↔ "SCRN SVR"  
 ↔ "MSG INP" ↔ "SCROLL" ↔ "DIMMER"  
 ↔ "A-CANCEL" ↔ "TEL-SP" ↔ "TEL-SW" ↔ "S-CHECK"
3. Press the [▲] or [▼] button to select the "desired setting value".
  - \* In the case of display blinking "ENT", you can press the [▶<sub>ENT</sub>] button to adjust the setting value.
  - \* After completing settings, press the [DISP] button to return to the previous mode.

### ● Setting the clock

- 2-1. Select "CLOCK".
- 3-1. Press the [▶<sub>ENT</sub>] button
- 3-2. Press the [◀◀] or [▶▶] button to select the hour or the minute.
- 3-3. Press the [▲] or [▼] button to set the correct time.
  - \* The clock is displayed in 12-hour format.
- 3-4. Press the [▶<sub>ENT</sub>] button to store the time into memory.

#### Note:

- You cannot set the clock when it is displayed with only the ignition on. If you drain or remove the car's battery or take out this unit, the clock is reset. While setting the clock, if another button or operation is selected, the clock set mode is canceled.

### ● Displaying the settings

The number of indicator of this unit decreases, you can see the state of current settings at any operation mode.

- 2-1. Select "SETTINGS".
- 3-1. Press the [▲] or [▼] button to display the state of current settings.
  - \* When the setting is selected, after 1 second the current state will be displayed.

For example:

SCN

after 1 second,

SCN ON

### ● Turning the screen saver function on or off

This unit is provided with the screen saver function which allows you to show various kinds of patterns and characters in the operation status indication area of the display in a random order. You can turn on or off this function. If the button operation is performed with the screen saver function on, the operation display corresponding to the button operation is shown for about 30 seconds and the display returns to the screen saver display.

\* The factory default setting is "ON".

- 2-1. Select "SCRN SVR".

- 3-1. Press the [▲] or [▼] button to select the setting.

Each time you press the [▲] or [▼] button, the setting changes in the following order:

"MESSAGE" ↔ "ON" ↔ "OFF"

### ● Entering message information

Message up to 30 characters long can be stored in memory and displayed as a type of screen saver setting.

\* The factory default setting is "WELCOME TO CLARION".

- 2-1. Select "MSG INP".

- 3-1. Press the [▶<sub>ENT</sub>] button.

- 3-2. Press and hold the [BND] button for 1 second or longer to clear the old message.

- 3-3. Press the [◀◀] or [▶▶] button to move the cursor.

- 3-4. Press the [BND] button to select a character type. Each time you press the [BND] button, the character type changes in the following order:

Capital letters → Numbers → Symbols → Capital letters...

- 3-5. Press the [▲] or [▼] button to select the desired character.

- 3-6. Repeat step 3-3 to 3-5 to enter up to 30 characters for message.

- 3-7. Press and hold the [▶<sub>ENT</sub>] button for 2 seconds or longer to store the message in memory.

\* Press and hold the [BND] button for 1 second or longer to cancel the input message. Then press and hold the [▶<sub>ENT</sub>] button for 2 seconds or longer to store the message and the message return to default setting.

## Operations Common to Each Mode

### ● Setting the method for title scroll

Set how to scroll in CD-TEXT, MP3/WMA/AAC title.

\* The factory default setting is "ON".

2-1. Select "SCROLL".

3-1. Press the [▲] or [▼] button to select "ON" or "OFF".

• **ON:**

To scroll automatically.

• **OFF:**

To scroll just 1 time.

\* When you want to see the title again, in the title mode, press and hold the [DISP] button for 3 seconds or longer to scroll the title.

### ● Setting the dimmer control

You can set the dimmer control "ON" or "OFF".

\* The factory default setting is "ON".

2-1. Select "DIMMER".

3-1. Press the [▲] or [▼] button to select "ON" or "OFF".

### ● Setting the external amplifier

\* The factory default setting is "OFF".

2-1. Select "A-CANCEL".

3-1. Press the [▲] or [▼] button to select "ON" or "OFF".

• **ON:**

Use with connected AMP.

• **OFF:**

Use with inside AMP.

### ● Setting the car speaker output for the cellular phone

\* The factory default setting is "RIGHT".

\* To output the telephone calls, set the cellular phone interrupt to "ON".

When the AUX input jack is used to connect an AUX BLUETOOTH BB (BLT370) (sold separately):

2-1. Select "TEL-SP".

3-1. Press the [▲] or [▼] button to select "RIGHT" or "LEFT".

• **RIGHT:**

Telephone calls can be heard on the front right speaker connected to this unit.

• **LEFT:**

Telephone calls can be heard on the front left speaker connected to this unit.

### ● Cellular phone interrupt setting

If you connect this unit and your cellular phone with a separately sold cable, you can listen to your telephone calls on your car speakers.

\* The factory default setting is "OFF".

2-1. Select "TEL-SW".

3-1. Press the [▲] or [▼] button to select the setting. Each time you press the [▲] or [▼] button, the setting changes in the following order:

"OFF" ↔ "ON" ↔ "MUTE"

• **OFF:**

This unit continues normal operation even when the cellular phone is used.

• **ON:**

You can listen to your telephone calls from the speakers connected to this unit.

\* When listening to your calls on your car speakers, you can adjust the volume by turning the [ROTARY] knob.

• **MUTE:**

The sound from this unit is muted during telephone calls.

**Note:**

• If connecting a hands-free kit, please ensure the setting is ON to receive the telephone audio through the system.

### ● Performing a system check

This function allows you to perform a system check from the adjust mode when required.

2-1. Select "S-CHECK".

3-1. Press and hold the [▶] button for 1 second or longer.

"S-CHECK" appears in the display, then the unit returns to the previous operation mode.



## Operations Common to Each Mode

### Entering titles

Titles up to 8 characters long can be stored in memory and displayed for CD, CD changer, Radio stations and TV stations. The number of titles that can be entered for each mode are as follows.

Mode	Number of titles
CD mode	50 titles
TV mode	20 titles
Radio mode	30 titles

CD changer mode	Number of titles
DCZ625 connected	100 titles

1. Press the **[SRC]** button to select the mode you want to enter a title (Radio, CD, CD changer or TV).
2. Select and play a CD in the CD changer or tune in to a TV station or Radio for which you want to enter the title.
3. Press and hold the **[DISP]** button for 1 second or longer.
4. Press the **[◀◀]** or **[▶▶]** button to select "TITLE IN".
5. Press the **[▶▶]** button.  
The display switches to the title input display.
6. Press the **[◀◀]** or **[▶▶]** button to move the cursor.
7. Press the **[BND]** button to select a character type. Each time you press the **[BND]** button, the character type changes in the following order:  
Capital letters → Numbers → Symbols → Capital letters...
8. Press the **[▲]** or **[▼]** button to select the desired character.
9. Repeat steps 6 to 8 to enter up to 8 characters for the title.
10. Press and hold the **[▶▶]** button for 2 seconds or longer to store the title into memory.

### Clearing titles

1. Select and play a CD in the CD changer or tune in to a TV station or Radio for which you want to clear the title.
2. Press and hold the **[DISP]** button for 1 second or longer.
3. Press the **[◀◀]** or **[▶▶]** button to select "TITLE IN".
4. Press the **[▶▶]** button.  
The display switches to the title input display.
5. Press and hold the **[BND]** button for 1 second or longer.  
All characters in the title disappear.
6. Press and hold the **[▶▶]** button for 2 seconds or longer to store the setting.

### AUX function

This system has an external input jack on the front panel so you can listen to sounds and music from external devices connected to this unit.

#### ● Selecting AUX IN sensitivity

Make the following settings to select the sensitivity when sounds from external devices connected to this unit are difficult to hear even after adjusting the volume.

\* The factory default setting is "MID".

1. Press and hold the **[DISP]** button for 1 second or longer.
2. Select "AUX SENS".
3. Press the **[▲]** or **[▼]** button to select "HIGH", "MID" or "LOW".

#### Note:

- When AUX mode is selected, AUX IN sensitivity can be set.

# 7. ACCESSORIES

## USB/MTP Operations

### USB memory/MTP device operation

#### Note:

- The following operations are the same as for CD mode:
    - \*Pause
    - \*Track selection
    - \*Fast-forward/fast-backward (Except DRM file)
    - \*Top function
    - \*Scan play
    - \*Repeat play
    - \*Random play
    - \*Folder selection
- See "CD/MP3/WMA/AAC Operations" (page 12-15) for details.

### About USB memory

- USB is an acronym for Universal Serial Bus, and refers to an external bus standard supporting data transfer rates of 12 Mbps.
- This unit is compatible with USB 1.1/2.0 with maximum data transfer rates of 12 Mbps.
- USB memory devices that can be played by connecting to the unit's USB cable are limited to those recognized as "USB mass storage class devices"; operation is not guaranteed with all USB memory devices.
  - \* Devices compatible with "USB Mass Storage Class" can be used merely by connecting to the host device, without need for special drivers or application software.
- Consult the manufacturer of your USB memory device for information regarding whether it is supported by "USB Mass Storage Class" standards.
- Audio files playable on this unit are limited to MP3/WMA/AAC files. For details, see the section "MP3/WMA/AAC" (page 12). Copy-protected WMA/AAC files cannot be played on this unit.
- To prevent the accidental loss of data, always back up important data on your computer.
- This unit does not support connections to a computer. In addition, connections made through a USB hub device are also not supported.

- When a USB memory device is composed of two or more drives, only one of the drives will be detected.
- USB memory devices with security functions cannot be played.
- The order in which tracks are recorded may differ depending on the USB memory device connected (the actual playback order may not be the same as that indicated on your computer's display).
- If you continuously operate folder up/down, the play time keeps as "00:00", and the sound is not emitted.

### About USB Digital Media Streaming

This unit supports USB Digital Media Streaming. USB Digital Media Streaming is a function used to play music files transmitted using Media Transfer Protocol (MTP). This function also supports the playback of WMDRM 10 files.

During USB Digital Media Streaming, the unit displays the "MTP" mode indicator.

Use of USB Digital Media Streaming requires the purchase of a supported portable audio player. For information regarding supported portable audio players, consult your nearest Clarion dealer, or visit Clarion's website.

### CAUTION

- **Insert and remove a USB memory/MTP device only when the device is not being accessed. Connecting or disconnecting the device at the following times may result in the loss of data:**
  - If the USB memory/MTP device is removed or power is disconnected during writing to the device.
  - When the device is subjected to static electricity or electric noise.
- **Do not leave a USB memory/MTP device unattended in an automobile. Exposure to direct sunlight or high temperatures may cause deformation or other malfunction of the USB memory/MTP device.**

## USB/MTP Operations

### Connecting a USB memory/MTP device

1. Connect the USB memory/MTP device to the USB slot.

Playback will begin from the first file recorded on the device.

#### **CAUTION**

**Do not turn on vehicle ignition when the MTP device is connected, since it may result in loss or damage to data on the MTP device.**

**Connect the MTP device to the USB slot after vehicle ignition is turned on.**

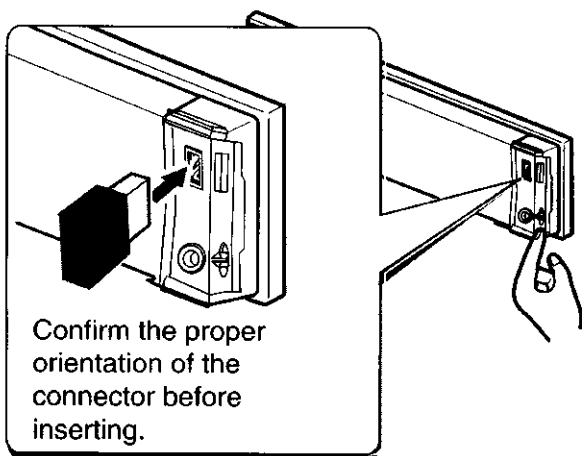

- \* If the device is not recognized, press the [SRC] button to switch the source to the device.
- \* Always insert the device fully into the connector. Incomplete connections may cause the device not to be recognized.
- \* Depending on the number of tracks recorded, some amount of time may be required until all tracks are read into the unit.
- \* The order in which tracks are recorded may differ depending on the device connected (the actual playback order may not be the same as that indicated on your computer's display).

### To listen to tracks on a connected USB memory/MTP device

1. Press the [SRC] button to switch the source. When USB memory/MTP device is selected, playback (except DRM files) will begin from the location at which playback was previously stopped.
  - \* When a USB memory/MTP device is connected the USB/MTP mode will be displayed.
  - \* When a USB memory/MTP device is disconnected and then reconnected, playback will begin from the beginning of the USB memory/MTP device.
  - \* When "MTP" mode is selected, AAC files on the MTP device cannot be played.

### To stop play

1. Press the [SRC] button and switch the function to a source other than the USB memory.

#### **CAUTION**

**Do not remove the USB memory/MTP device when the USB/MTP mode is selected, since it may result in loss or damage to data on the USB memory/MTP device.**

**Always backup and save important data on your computer.**

2. Remove the USB memory/MTP device from the USB slot.

# iPod Operations

This section describes operations when connected to an Apple iPod via the USB slot.

## Notes:

- See the iPod Owner's Manual for details regarding operation conditions.
- The unit will not operate, or may operate improperly with unsupported versions.
- For a list of compatible Apple iPod unit with the this model, please contact your Clarion dealer or [www.clarion.com](http://www.clarion.com).
- "Made for iPod" means that an electronic accessory has been designed to connect specifically to iPod and has been certified by the developer to meet Apple performance standards.  
Apple is not responsible for the operation of this device or its compliance with safety and regulatory standards.  
iPod and iTunes are trademarks of Apple Inc., registered in the U.S. and other countries.

## Connecting an iPod

When an iPod is connected to the USB slot, "Shuffle" set on the iPod will become as follows:

- "Shuffle (Albums)" play → Random play
- "Shuffle (Songs)" play → All random play

The iPod has two modes, the "Play mode" and the "iPod menu mode" for selecting tracks. Switch between these modes by pressing the [BND] button for 1 second or longer.

## Note:

- To connect iPod, please use the USB cable attached in iPod.

## Select iPod mode

1. Press the [SRC] button.

Playback will begin from the last file that was played on the iPod.

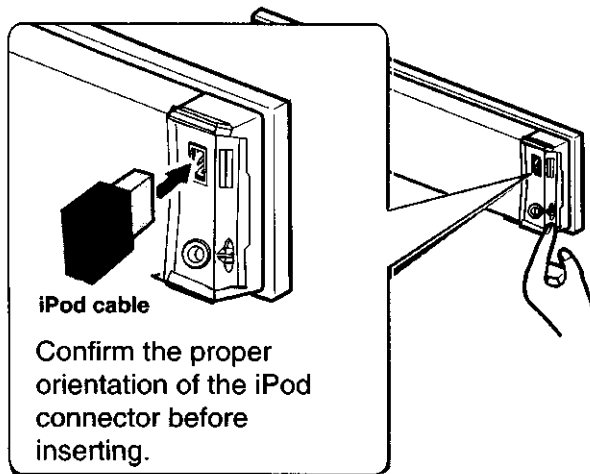

## Note:

- The following operations in Play mode operate the same as in CD mode:
    - \*Track selection: [◀◀], [▶▶]
    - \*Fast-forward/fast-backward: [◀◀], [▶▶]
    - \*Pause: [▶||]
    - \*Top function: [BND]
- See "CD/MP3/WMA/AAC Operations" (page 12-15) for details.

## Other various play functions (in Play mode)

### Notes:

- These functions are not supported when in the iPod menu mode.
- The Random function set on the iPod remains the same after attachment/detachment of the iPod.
- The Repeat function on the iPod will be changed when you connect/disconnect the iPod to the unit.

### ● Repeat play

Play back one track repeatedly.

1. Press the [RPT] button.

### ● Random play

Play all albums within a selected category, in random order. (Corresponds to "Shuffle (Albums)" command on iPod.)

1. Press the [RDM] button.

### ● All random play

Play all tracks within a selected category, in random order. (Corresponds to "Shuffle (Songs)" command on iPod.)

1. Press and hold the [RDM] button for 1 second or longer.

### ● To cancel play

1. Press the same play button once again.

### Notes:

- When the repeat play mode is canceled, after play all tracks within a selected category, playback will begin from the first track in the selected category.
- When playing the last track within a selected category in Random mode, if ACC is switched off then on again, playback will begin from a different track.
- Though the default setting of an iPod is "All Repeat", the indication on the mode status is not displayed.

**Selecting category from the iPod menu**

1. Press and hold the **[BND]** button for 1 second or longer to select the iPod menu mode.

The iPod menu categories will be displayed.

**Notes:**

- Repeat and Random mode operations are not supported when in the iPod menu mode.
- In iPod menu mode, if you press the **[◀◀]/[▶▶]** or **[▲]/[▼]** button fast, playback may not be performed.

2. Press the **[▲]** or **[▼]** button to switch between categories.

The iPod menu categories alternate in the following order:

**“PLAYLIST” ↔ “ARTIST” ↔ “ALBUM” ↔ “SONG” ↔ “GENRE” ↔ “COMPOSER”...**

**Note:**

The iPod menu mode can be canceled by performing one of the following operations:

- Press the **[BND]** button.
  - When the category select screen is displayed, press the **[▶▶]** button.
3. Press the **[▶▶]** button to select the category.
  4. When the track name display is showing, press the **[▶▶]** button.

Playback will begin from the first track in the selected category, and the iPod menu mode will be canceled.

- \* Subfolders may be displayed, depending on the category.

In this case, use the **[▲]** and **[▼]** buttons to switch between subfolders, then use the **[▶▶]** button to select the desired subfolder.

- \* When the track name display is showing, pressing the **[◀◀]** button will return to the currently playing folder name display.

5. Use the **[▲]** and **[▼]** buttons to select a track within a category.

**Selecting category using preset memory**

1. Press and hold the **[BND]** button for 1 second or longer to select the iPod menu mode.

The category can be set as follows in the **[DIRECT]** (1-6) buttons.

**[1] : PLAYLIST**

**[2] : ARTIST**

**[3] : ALBUM**

**[4] : SONG**

**[5] : GENRE**

**[6] : COMPOSER**

2. Press the desired **[DIRECT]** (1-6) button to select the category.

- \* Subfolders may be displayed, depending on the category.

In this case, use the **[▲]** and **[▼]** buttons to switch between subfolders, then use the **[▶▶]** button to select the desired subfolder.

3. When the track name display is showing, press the **[▶▶]** button.

Playback will begin from the first track in the selected category, and the iPod menu mode will be canceled.

- \* Use the **[▲]** and **[▼]** buttons to select a track within a category.

**About title display**

This unit supports the display of title information transmitted from a connected iPod.

- Character code information is UTF-8; displayable characters include English alphanumerics, some symbols, and some umlaut characters.
- Unsupported characters will be replaced by asterisks (\*).

# Satellite Radio Operations

This function is available when a Satellite Radio Receiver is connected through the CeNET cable.

This unit can control the following satellite radio receivers:

- XM Satellite Interface Adapter (Mini-Tuner Included) : CNP2000UC  
Clarion cable for CNP2000UC : CNPCLA1
- SIRIUS Satellite Radio Receiver : SIRCL3
- SIRIUS Satellite Translator Adapter : CLA-SC1 (which needs Sirius universal Tuner sold separately.)

## Notes:

- When the function is differ depending to the connected receiver, they are distinguished by the following notations:  
"XM": for an XM Satellite Radio Receiver  
"SIRIUS": for a SIRIUS Satellite Radio Receiver
- XM and the XM logos are trademarks of XM Satellite Radio Inc.

## Selecting a Satellite Radio mode

1. Press the [SRC] button.  
The system changes to the specified Satellite Radio mode.

## Selecting a band

1. Press the [BND] button to select a band.  
This changes the reception band as follows:

- XM: XM1 → XM2 → XM3 → XM1 ...
- SIRIUS: SR1 → SR2 → SR3 → SR1 ...

### ● Information displayed during reception

The following information is displayed when the satellite radio cannot be received normally.

- When the receiver is turned on the first time or after a reset: "UPDATING"
- When a channel is being tuned in (no signal is yet received):  
XM: "LOADING", SIRIUS: "LINKING"
- A channel without a broadcast has been selected:  
XM: "-- -- CH", SIRIUS: "INVALID CH"
- A channel not covered by your contract:  
XM: "UPDATING", SIRIUS: "CALL 888" ↔ "539-SIRI" (alternated)

## Confirming your SIRIUS ID

1. Press and hold the [DISP] button for 1 second or longer to display the ADJUST item.
2. Press the [◀◀] or [▶▶] button to select "SID DISP".
3. Press the [▶<sub>ENT</sub>] button, the display will display the upper 6 digits.
4. Press the [▲] or [▼] button to switch between the display for the upper 6 digits and lower 6 digits.
5. To return to the previous mode, press the [DISP] button.

## Displaying channel labels

1. Press the [DISP] button to select the desired channel label.  
Channel → Category → Title (Artist) → Radio text → Channel...

## Channel selection

1. Channels are selected with the [◀◀] or [▶▶] button.  
\* For details, see the following operation descriptions.

### Note:

- The audio output is muted and other button operations are not accepted during channel selection.

## Tuning mode

There are two channel selection modes: quick tuning mode and step tuning mode.

### ● Quick tuning

1. Press and hold the [◀◀] or [▶▶] button for 1 second or longer.

### ● Step tuning

1. Press the [◀◀] or [▶▶] button.

## Recalling a preset station

A total of 18 satellite radio stations can be stored.

- **XM:** 6-XM1, 6-XM2 and 6-XM3
- **SIRIUS:** 6-SR1, 6-SR2 and 6-SR3

This allows you to store your favorite satellite radio stations in memory for later recall.

1. Press the **[BND]** button to select the desired band.
2. Press the **[▲]** / **[▼]** button or **[DIRECT]** button to select the desired preset station.

## Preset memory

1. Press the **[BND]** button to select the desired band.
2. Select the desired channel with quick tuning or step tuning.
3. Press and hold the **[DIRECT]** button for 2 seconds or longer to store the current channel into preset memory.

## Receiving stations selected by category

Satellite Radio allows you to select broadcast channel category (contents).

1. Press and hold the **[BND]** button for 1 second or longer to select the category selection mode.
  - \* It press once again, return to the channel selection mode.
2. Press the **[▲]** or **[▼]** button to change the category item.
3. Press the **[◀◀]** or **[▶▶]** button to tune in a station.

### Notes:

- When the category selection mode is entered, the category of the last received channel is displayed first.
- The category selection mode is canceled when no channel with the selected category can be found.
- The **[◀◀]** or **[▶▶]** button are not pressed within 7 seconds, the category selection mode is canceled, and resumes to the channel mode.

## Presetting a category

A category can be preset by registering specific categories in **[DIRECT]** buttons 1 to 6. Then the desired category can be recalled by pressing the corresponding **[DIRECT]** button.

1. Press and hold the **[BND]** button for 1 second or longer to enter the category mode.
2. Press the **[▲]** or **[▼]** button to select a category.
3. Press and hold one of the **[DIRECT]** buttons for 2 seconds or longer to store the current category into preset memory.

### Notes:

- When the name of a channel stored in memory is changed by a broadcasting channel, the display may show a channel name that differs from the stored name.
- A channel stored in memory may be discontinued at the option of the broadcasting channel.
- If no operation is performed for more than 1 second, category seek tuning can automatically tune in a receivable broadcast channel category.

## Scan function

There are two scan modes: the category scan mode and the preset scan mode.

During scanning channels are displayed in abbreviated form, the display mode cannot be switched.

### ● Preset scan (PRESET SCN)

A preset scan scans the channels (up to 18 channels) stored in the preset memory about every 10 seconds.

Press and hold the **[▶<sup>II</sup>ENT]** button for 1 second or longer to select the preset scan mode. And start the preset scanning.

### ● Category scan (CAT SCN)

In a category scan, broadcast channels in the same category as the current channel are selected about every 10 seconds.

Press the **[▶<sup>II</sup>ENT]** button to select the category scan mode. And start the category scanning.

### Note:

- Category scanning is not available when no category is defined for the current channel.

# CD Changer Operations

## Note:

- The following operations are the same as for CD mode:

- \*Pause
- \*Track selection
- \*Fast-forward/fast-backward
- \*Scan play
- \*Repeat play
- \*Random play

See "CD/IMP3/WMA/AAC Operations" (page 12-15) for details.

## CD changer functions

When an optional CD changer is connected through the CeNET cable, this unit controls all CD changer functions. This unit can control a total of 2 changers.

Press the [SRC] button and select the CD changer mode to start play. If 2 CD changers are connected, press the [SRC] button to select the CD changer for play.

- \* If "NO MAG" appears in the display, insert the magazine into the CD changer. "D-CHECK" appears in the display while the player loads (checks) the magazine.
- \* If "NO DISC" appears in the display, eject the magazine and insert discs into each slot. Then, reinsert the magazine back into the CD changer.

## Note:

- Some CDs recorded in CD-R/CD-RW mode may not be usable.

## CAUTION

CD-ROM discs cannot be played from every CD changer, it's depended on the model.

## Displaying CD titles

This unit can display title data for CD-text CDs and user titles input with this unit.

- \* Title data for CD-text CDs can be displayed with this unit only when it is connected to DCZ625.

1. Press the [DISP] button to change the title display.

## Notes:

- If the CD playing is not a CD-text CD or no user title has been input, "NO TITLE" appears in the display.
- If a CD-text CD is not input its disc title or a track title, "NO TITLE" appears in the display.

## Procedure to scroll a title

Set "SCROLL" to "ON" or "OFF".

(The factory default setting is "ON". Refer to the subsection "Setting the method for title scroll" in section "Operations Common to Each Mode".)

### ● When set to "ON"

The title is automatically kept scrolling.

### ● When set to "OFF"

To scroll just 1 time.

When you want to see the title again, in the title mode, press and hold the [DISP] button for 3 seconds or longer to scroll the title.

## Selecting a CD

1. Press the [▲] or [▼] button to select the desired disc.
  - \* If a CD is not loaded in a slot of magazine, pressing the [▲] or [▼] button can not work.

## Other various play functions

### ● Disc scan play

Disc scan play locates and plays the first 10 seconds of the first track on each disc in the currently selected CD changer. This function continues automatically until it is cancelled.

- \* Disc scan play is useful when you want to select a desired CD.

1. Press and hold the [SCN] button for 1 second or longer. "ALL SCAN" appears in the display and disc scan play starts.

### ● Disc repeat play

After all the tracks on the current disc have been played, disc repeat play automatically replays the current disc over from the first track. This function continues automatically until it is cancelled.

1. Press and hold the [RPT] button for 1 second or longer. "ALL RPT" appears in the display and disc repeat play starts.

### ● Disc random play

The disc random play selects and plays individual tracks or discs automatically in no particular order. This function continues automatically until it is cancelled.

1. Press and hold the [RDM] button for 1 second or longer. "ALL RDM" appears in the display and disc random play starts.

### ● To cancel play

1. Press the operating button previously selected.



# DVD Changer Operations

By connecting an optional DVD changer that supports CeNET wiring, this unit can be used to control the DVD changer. To view DVDs, an optional monitor is required.

- The DVD control and display functions supported by this unit are limited; the unit does not support all the functions possible on a DVD changer.

For fullest functionality, use the remote control unit provided with your DVD changer to control its operations. For details, consult the Owner's Manual provided with your DVD changer.

## Note:

- The following operations are the same as for CD and CD Changer modes:

\*Pause

\*Track selection

\*Fast-forward/fast-backward

\*Scan play

\*Repeat play

\*Random play

See "CD/MP3/WMA/AAC Operations" (page 12-15) and "CD Changer Operations" (page 25) for details.

## TV Operations

### Note:

- The following operations are performed the same as for radio mode:

\*Channel selection

\*Storing channels in memory

\*Calling channels from memory

\*Auto store

\*Preset scan

See "Radio Operations" (page 11-12) for details.

### TV tuner functions

When an optional TV tuner is connected through the CeNET cable, this unit controls all TV tuner functions. To watch TV requires a TV tuner and monitor.

### Watching a TV

1. Press the [SRC] button and select the TV mode.
2. Press the [BND] button to select the desired TV band (TV1 or TV2). Each time the button is pressed, the input selection toggles between TV1 and TV2.
3. Press the [◀◀] or [▶▶] button to tune in the desired TV station.

### Watching a video

The TV tuner has a VTR input terminal to which 1 external device can be connected. Connect a 12 V video cassette player (VCP) or video cassette recorder (VCR) to the TV tuner input terminal.

- \* The factory default setting is "TV".

1. Press and hold the [DISP] button for 1 second or longer to switch to the adjustment selection display.
2. Press the [◀◀] or [▶▶] button to select "TV/VTR".
3. Press and hold the [▶▶] button for 1 second or longer to set to "VTR".
4. To return to the TV broadcast, press and hold the [DISP] button for 1 second or longer to switch to the adjustment selection display.
5. Press the [◀◀] or [▶▶] button to select "TV/VTR".
6. Press and hold the [▶▶] button for 1 second or longer to set to "TV".

### Setting the TV diver

You can change the reception setting for the TV antenna connected to the TV tuner.

- \* The factory default setting is "ON".

1. Press and hold the [DISP] button for 1 second or longer to switch to the adjustment selection display.
2. Press the [◀◀] or [▶▶] button to select "TV DIVER".
3. Press the [▲] or [▼] button to set to "ON" or "OFF".
  - ON: Sets the diver setting to ON.
  - OFF: Sets the diver setting to OFF.
4. Press the [DISP] button to return to the previous mode.

# 8. TROUBLESHOOTING

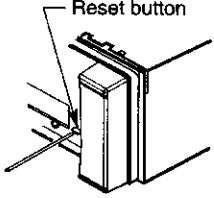
Problem	Cause	Measure
Power does not turn on. (No sound is produced.)	Fuse is blown.	Replace with a fuse of the same amperage. If the fuse blows again, consult your store of purchase.
	Incorrect wiring.	Consult your store of purchase.
No sound output when operating the unit with amplifiers or power antenna attached.	Power antenna lead is shorted to ground or excessive current is required for remote-on the amplifiers or power antenna.	<ol style="list-style-type: none"> <li>1. Turn the unit off.</li> <li>2. Remove all wires attached to the power antenna lead. Check each wire for a possible short to ground using an ohm meter.</li> <li>3. Turn the unit back on.</li> <li>4. Reconnect each amplifier remote wire to the power antenna lead one by one. If the amplifiers turn off before all wires are attached, use an external relay to provide remote-on voltage (excessive current required).</li> </ol>
Nothing happens when buttons are pressed.  Display is not accurate.	The microprocessor has malfunctioned due to noise, etc.	Turn off the power, then press the <b>[RELEASE]</b> button and remove the DCP. Press the reset button for about 2 seconds with a thin rod. If the RESET button is pressed when a disc is loaded, please eject the disc and load it once again before attempting to play it. 
	DCP or main unit connectors are dirty.	Wipe the dirt off with a soft cloth moistened with cleaning alcohol.
No sound heard	The speaker protection circuit is operating.	<ol style="list-style-type: none"> <li>1. Turn down sound volume. Function can also be restored by turning the power off and on again. (Speaker volume is reduced automatically when the speaker protection circuit operates).</li> <li>2. If the sound is muted again, consult our service department.</li> </ol>

	Problem	Cause	Measure
COMPACT/MP3/WMA/AAC	No sound heard	MP3/WMA/AAC files are absent in a disc.	Write MP3/WMA/AAC files onto the disc properly.
		Files are not recognized as an MP3/WMA/AAC file.	Use MP3/WMA/AAC files encoded properly.
		File system is not correct.	Use ISO9660 level 1, 2 or JOLIET or Romeo or APPLE ISO file system.
	Sound skips or is noisy.	Compact disc is dirty.	Clean the compact disc with a soft cloth.
		Compact disc is heavily scratched or warped.	Replace with a compact disc with no scratches.
	Sound is cut or skipped. Noise is generated or noise is mixed with sound.	MP3/WMA/AAC files are not encoded properly.	Use MP3/WMA/AAC files encoded properly.
Sound is bad directly after power is turned on.	Water droplets may form on the internal lens when the car is parked in a humid place.	Let dry for about 1 hour with the power on.	
Wrong filename	File system is not correct.	Use ISO9660 level 1, 2 or JOLIET or Romeo or APPLE ISO file system.	
USB/MP3/Ipod	No sound heard	The device contains no MP3/WMA/AAC files.	Record MP3/WMA/AAC files properly to the device.
		The files are not proper MP3/WMA/AAC format.	Use only properly encoded MP3/WMA/AAC files.
		Connectors are loose.	Disconnect the device and reconnect securely.
	Sound is interrupted or has noise.	The MP3/WMA/AAC files are improperly encoded.	Use only properly encoded MP3/WMA/AAC files.
	The device isn't recognized.	The device is damaged.	Disconnect the device and reconnect. If the device is still not recognized, try replacing with a different device.
		Connectors are loose.	
		According to the state of operation on the device, the communication fault is caused.	Disconnect the device and reconnect.
Can't insert the device.	The device has been inserted improperly.	Try reversing the connection direction of the device (usually the brand name surface should be facing left).	
	The connector is broken.	Replace with a new device.	

# 9. ERROR DISPLAYS

If an error occurs, one of the following displays is displayed.

Take the measures described below to eliminate the problem.

	Error Display	Cause	Measure
CDMP3/WMA/AAC	ERROR 2	A CD is caught inside the CD deck and is not ejected.	This is a failure of CD deck's mechanism and consult your store of purchase.
	ERROR 3	A CD cannot be played due to scratches, etc.	Replace with a non-scratched, non-warped-disc.
	ERROR 6	A CD is loaded upside-down inside the CD deck and does not play.	Eject the disc then reload it properly.
CD changer	ERROR 2	A CD inside the CD changer is not loaded.	This is a failure of CD changer's mechanism and consult your store of purchase.
	ERROR 3	A CD inside the CD changer cannot be played due to scratches, etc.	Replace with a non-scratched, non-warped disc.
	ERROR 6	A CD inside the CD changer cannot be played because it is loaded upside-down.	Eject the disc then reload it properly.
DVD changer	ERROR 2	A DISC inside the DVD changer cannot be played.	This is a failure of DVD mechanism and consult your store of purchase.
	ERROR 3	A DISC cannot be played due to scratches, etc.	Retry or replace with a non-scratched, non-warped-disc.
	ERROR 6	A DISC inside the DVD changer cannot be played because it is loaded upside-down.	Eject the disc then reload it properly.
	ERROR P	Parental level error	Set the correct Parental level.
	ERROR R	Region code error	Eject the disc and replace correct region code disc.
USB/MTP/iPod	ERROR 2	The files are not proper MP3/WMA/AAC format.	Use only properly encoded MP3/WMA/AAC files.
	ERROR 3 (USB/MTP mode)	The MP3/WMA/AAC files are improperly encoded.	Use only properly encoded MP3/WMA/AAC files.
	ERROR 3 (iPod mode)	The iPod contains no audio files.	Insert an iPod containing audio files.
	CUR ERR	Overcurrent detection.	Disconnect the devices and reconnect. If the devices are still not recognized, try replacing with a different devices.
	HUB ERR	Do not support the HUB devices.	Do not use the HUB devices.

If an error display other than the ones described above appears, press the reset button. If the problem persists, turn off the power and consult your store of purchase.

# 10. SPECIFICATIONS

## FM Tuner

Frequency Range: 87.9 MHz to 107.9 MHz  
 Usable Sensitivity: 11 dB $\mu$ V  
 50dB Quieting Sensitivity: 17 dB $\mu$ V  
 Alternate Channel Selectivity: 60 dB  
 Stereo Separation (1 kHz): 30 dB  
 Frequency Response ( $\pm$ 3 dB): 30 Hz to 15 kHz

## AM Tuner

Frequency Range: 530 kHz to 1710 kHz  
 Usable Sensitivity: 28 dB $\mu$ V

## CD Player

System: Compact disc digital audio system  
 Usable Discs: Compact disc  
 Frequency Response ( $\pm$ 1 dB): 20 Hz to 20 kHz  
 Dynamic Range (1 kHz): 80 dB  
 Harmonic Distortion: 0.03%

## Audio

Maximum Power Output: 200 W (50 W  $\times$  4 ch)  
 Bass Control Action (100 Hz): +14 dB, -14 dB  
 Treble Control Action (10 kHz): +14 dB, -14 dB  
 Line Output Level (CD 1 kHz): 2 V

### Note:

- Specifications and design are subject to change without notice for further improvement.

## General

Power Supply Voltage:  
 14.4 V DC (10.8 to 15.6 V allowable), negative ground  
 Current Consumption: Less than 15 A  
 Speaker Impedance: 4  $\Omega$  (4  $\Omega$  to 8  $\Omega$  allowable)  
 Auto Antenna Rated Current: 500 mA or less  
 Weight / Source unit: 2.53 lb. (1.14 kg)  
 Weight / Remote control unit:  
 1.41 oz. (40 g) (including battery)  
 Dimensions / Source unit:  
 7" (Width)  $\times$  2" (Height)  $\times$  6-1/8" (Depth)  
 [178 (W)  $\times$  50 (H)  $\times$  155 (D) mm]  
 Dimensions / Remote control unit:  
 1-3/4" (Width)  $\times$  4-5/16" (Height)  $\times$  7/16"  
 (Depth)  
 [44 (W)  $\times$  113 (H)  $\times$  11 (D) mm]

### Power Output :

20 W RMS  $\times$  4 Channels at 4  
 and 1 % THD+N

### Signal to Noise Ratio:

90 dBA (reference: 1 W into 4 )



# 11. OTHERS

## WMDRM 10 for devices

- This product is protected by certain intellectual property rights of Microsoft. Use or distribution of such technology outside of this product is prohibited without a license from Microsoft.
- Content owners use Windows Media digital rights management technology (WMDRM) to protect their intellectual property, including copyrights. This device uses WMDRM software to access WMDRM-protected

content. If the WMDRM software fails to protect the content, content owners may ask Microsoft to revoke the software's ability to use WMDRM to play or copy protected content. Revocation does not affect unprotected content. When you download licenses for protected content, you agree that Microsoft may include a revocation list with the licenses. Content owners may require you to upgrade WMDRM to access their content. If you decline an upgrade, you will not be able to access content that requires the upgrade.

# Clarion Co., Ltd.

---

All Rights Reserved. Copyright © 2008: Clarion Co., Ltd.  
Printed in China / Imprimé en Chine / Impreso en China

2008/9

**PE-3045B**  
**280-8584-01**



# Installation/Wire Connection Guide Manuel d'installation et de connexion Guía de instalación/conexión de cables

English Français Español

## 1. BEFORE STARTING / PRÉPARATIFS / ANTES DE COMENZAR

1. This set is exclusively for use in cars with a negative ground, 12 V power supply.
2. Read these instructions carefully.
3. Be sure to disconnect the battery "⊖" terminal before starting. This is to prevent short circuits during installation. (Figure 1)

1. Cet appareil est exclusivement destiné à être utilisé dans les voitures avec une alimentation 12 V à masse négative.
2. Lire ces instructions attentivement.
3. S'assurer de débrancher la borne "⊖" de la batterie avant de commencer. Cela évitera les courts-circuits pendant l'installation. (Figure 1)

1. Esta unidad ha sido diseñada para utilizarse exclusivamente en automóviles con fuente de alimentación de 12 V, y negativo a masa.
2. Lea cuidadosamente estas instrucciones.
3. Antes de comenzar, cerciórese de desconectar el terminal "⊖" de la batería. Esto es para evitar cortocircuitos durante la instalación. (Figure 1)

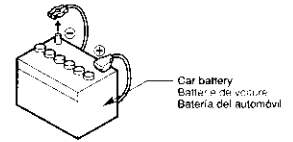

Figure 1 / Figure 1 / Figura 1

English Français Español

## 2. CAUTIONS ON INSTALLATION / PRÉCAUTIONS AU SUJET DE L'INSTALLATION / PRECAUCIONES PARA LA INSTALACIÓN

1. Prepare all articles necessary for installing the source unit before starting.
2. Install the unit within 30° of the horizontal plane. (Figure 2)
3. If you have to do any work on the car body, such as drilling holes, consult your car dealer beforehand.
4. Use the enclosed screws for installation. Using other screws can cause damage. (Figure 3)

1. Avant de commencer, préparez toutes les pièces nécessaires pour installer l'appareil pilote.
2. Installez l'appareil avec un angle inférieur à 30° par rapport au plan horizontal. (Figure 2)
3. Si il est nécessaire d'effectuer des travaux sur la carrosserie, consultez votre concessionnaire automobile.
4. Utiliser les vis fournies pour l'installation. L'utilisation de vis peut causer des dommages. (Figure 3)

1. Antes de comenzar, prepare todos los elementos necesarios para instalar la unidad fuente.
2. Instale la unidad con un ángulo de 30° sobre el plano horizontal. (Figure 2)
3. Si tiene que realizar cualquier trabajo en la carrocería, como taladrado de orificios, etc., consulte al proveedor de su automóvil.
4. Use los tornillos incluidos para la instalación. El uso de otros tornillos puede causar daños. (Figure 3)

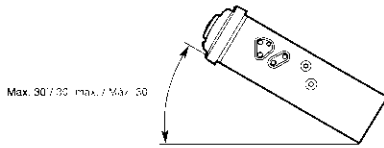

Figure 2 / Figure 2 / Figura 2

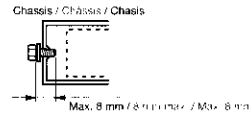
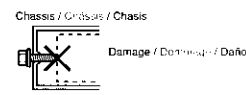

Figure 3 / Figure 3 / Figura 3



English Français Español

## 3. INSTALLING THE SOURCE UNIT / INSTALLATION DE L'APPAREIL PILOTE / INSTALACIÓN DE LA UNIDAD FUENTE

### ■ Universal Mount

1. Place the universal mounting bracket into the instrument panel, use a screwdriver to bend each stopper of the universal mounting bracket inward, then secure the stopper as shown in Figure 4.
2. Wire as shown in Section 6.
3. Insert the source unit into the universal mounting bracket until it locks.
4. Take care of the top and bottom of the outer escutcheon and mount it so that all the hooks are locked.

### ■ Montage universel

1. Placer le support de montage universel dans le tableau de bord. Déformer les tournevis pour replier vers l'intérieur chaque languette du support de montage universel, puis fixer les languettes comme montré sur la Figure 4.
2. Câbler comme montré dans la Section 6.
3. Insérer l'appareil pilote dans le support de montage universel jusqu'à ce qu'il soit bloqué.
4. Repérer le haut et le bas de l'écusson extérieur et le monter de manière que tous les crochets soient verrouillés.

### ■ Montaje universal

1. Coloque el soporte de montaje universal en el tablero de instrumentos, utilice un destornillador para doblar cada retén del soporte de montaje universal hacia adentro, y después asegure el retén como se muestra en la Figura 4.
2. Conecte los cables como se muestra en la Sección 6.
3. Inserte la unidad fuente en el soporte de montaje universal hasta que quede enganchado.
4. Tenga cuidado con la partes superior e inferior de la pieza ornamental exterior, y móntela de forma que todos los ganchos queden bloqueados.

**Notes:**  
 1) Some car models require special mounting kits for proper installation. Consult your Clarion dealer for details.  
 2) Fasten the front stopper securely to prevent the source unit from coming loose.

**Remarques:**  
 1) Certains modèles de voiture nécessitent un kit de montage spécial pour une installation correcte. Consulter le revendeur Clarion pour les détails.  
 2) Serrer fermement la languette avant pour éviter que l'appareil pilote ne se détache.

**Notas:**  
 1) Algunos modelos de automóviles requieren juegos de montaje especiales para realizar la instalación apropiada. Solicite los detalles a su proveedor Clarion.  
 2) Apriete con seguridad el retén frontal para evitar que se afloje la unidad fuente.

• Console opening dimensions  
 • Dimensions d'ouverture de la console  
 • Dimensiones de la abertura de la consola

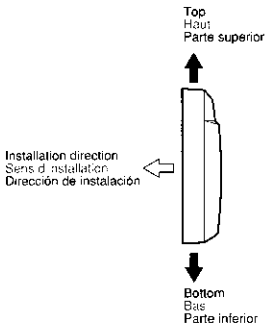
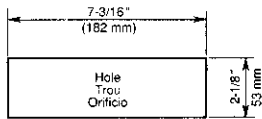

Outer escutcheon side view  
 Vue latérale de l'écusson extérieur  
 Vista lateral de la pieza ornamental exterior

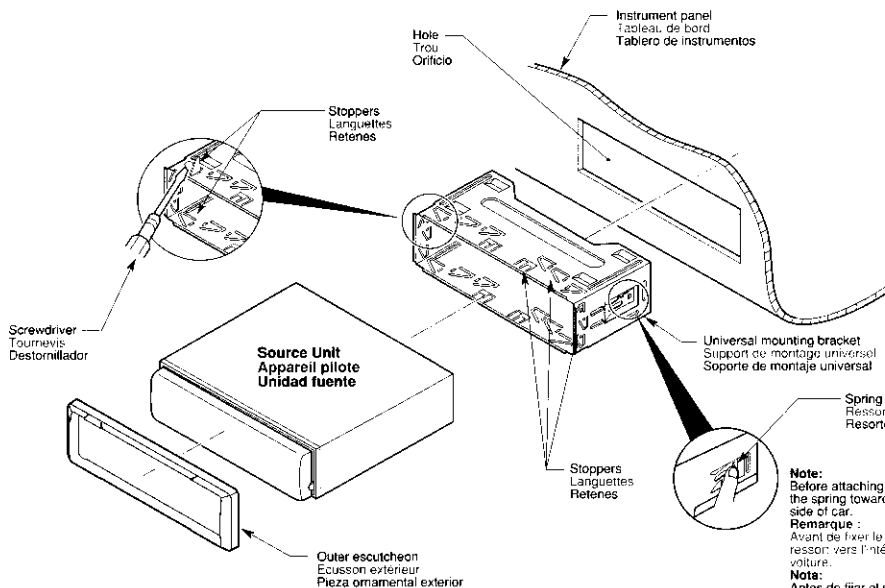

**Note:**  
 Before attaching the universal mounting bracket, slightly bend the spring toward the inside with your fingers and attach it to the side of car.  
**Remarque:**  
 Avant de fixer le patin de montage universel, pliez légèrement le ressort vers l'intérieur avec les doigts et fixez-le sur le côté de la voiture.  
**Nota:**  
 Antes de fijar el soporte de montaje universal, doble ligeramente el resorte hacia el interior con los dedos y fíjelo en la parte lateral del automóvil.

Figure 4 / Figure 4 / Figura 4

### Fixed Mount (TOYOTA, NISSAN and other ISO/DIN equipped vehicles)

This unit is designed for fixed installation in the dashboard. If the vehicle is equipped with a factory-installed radio, install the source unit with the parts and screws marked (\*) (Figure 7). If the vehicle is not equipped with a factory-installed radio, obtain an installation kit to install the source unit in the following procedure.

Bend the stopper following the procedures below when this source unit is installed to the TOYOTA, NISSAN and other ISO/DIN equipped vehicles.

1. Bend the stopper from the source unit. (Figure 5, 6)

### Montaje fijo (TOYOTA, NISSAN et autres véhicules équipés ISO/DIN)

Cette unité est conçue pour une installation fixe dans le tableau de bord. Si votre véhicule est équipé d'un radio d'origine, installez l'appareil pilote avec les pièces et vis marquées (\*) (Figure 7). Si votre véhicule n'est pas équipé d'un radio d'origine, obtenez un kit d'installation pour installer l'appareil pilote dans la procédure suivante.

Pliez le stoppeur suivant les procédures ci-dessous lorsque cette source d'alimentation est installée dans le tableau de bord d'un véhicule TOYOTA, NISSAN ou d'un autre véhicule équipé ISO/DIN.

1. Pliez le stoppeur de l'unité source. (Figure 5, 6)

### Montaje fijo (Automóviles TOYOTA, NISSAN, y otros provistos de normas ISO/DIN)

Esta unidad ha sido diseñada para instalarse de forma fija en el tablero de instrumentos. Si el automóvil dispone de una radio instalada en fábrica, instale la unidad fuente con las piezas y los tornillos marcados con (\*) en la Figura 7. Si el automóvil no dispone de una radio instalada en fábrica, adquiera un juego de instalación para instalar la unidad fuente de acuerdo con el procedimiento siguiente.

Doble de instalar esta unidad en vehículos TOYOTA, NISSAN, y otros equipados con ISO/DIN, extraiga el retén siguiendo los procedimientos indicados a continuación.

1. Doble el retén procedente de la unidad fuente. (Figura 5, 6)

BEFORE BEND/AVANT LA COURBURE/ANTES DE DOBLAR

AFTER BEND/APRES LA COURBURE/DESPUES DE DOBLAR

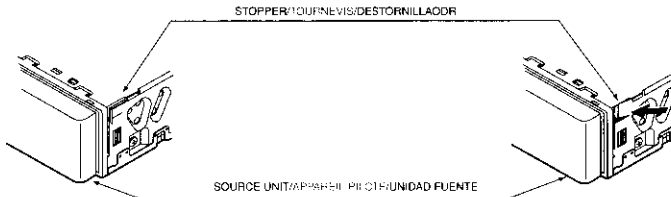

Figure 5/ Figure 5/ Figura 5

Figure 6/ Figure 6/ Figura 6

2. Secure the mounting brackets to the chassis as shown in Figure 7. Holes are pre-tapped for TOYOTA and NISSAN vehicles; modification, such as drilling new holes, of the mounting brackets may be required for other models.
3. Wire as shown in Section 8.
4. Secure the unit in the dashboard, and then reassemble the dashboard and the center panel.

2. Assurez-vous que les supports de montage sont fixés au châssis comme il est montré à la Figure 7. Les orifices ont déjà été percés sur les véhicules TOYOTA et NISSAN; des modifications, telles que le perçage de nouveaux trous, des supports de montage peuvent être nécessaires pour d'autres modèles.
3. Connectez les câbles comme il est montré dans la Section 8.
4. Assurez-vous que l'unité est fixée dans le tableau de bord, puis remontez le tableau de bord et le panneau central.

2. Asegure los soportes de montaje al chasis como se muestra en la Figura 7. Los orificios ya han sido taladrados en los automóviles TOYOTA y NISSAN, pero para otros modelos puede resultar necesario realizar modificaciones, como taladrado de nuevos orificios en los soportes de montaje.
3. Conecte los cables como se muestra en la Sección 8.
4. Asegure la unidad al tablero de instrumentos, y después vuelva a montar el tablero de instrumentos y el panel central.

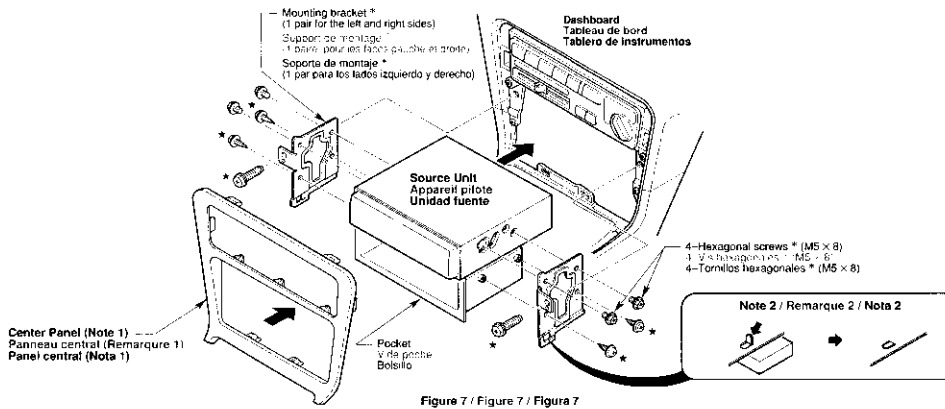

Figure 7 / Figure 7 / Figura 7

- \* The parts and screws with this mark are used to install radio or included in the installation kit.
- \* The screws with this mark are originally attached to the vehicle.
- Note 1: In some cases, the center panel may require some modification (trimming, filing, etc.).
- Note 2: If a hook on the installation bracket interferes with the unit, bend and flatten it with a nipper or a similar tool.

- \* Les pièces et vis avec cette marque sont utilisées pour installer la radio ou se trouvent dans le kit d'installation.
- \* Les vis avec cette marque sont d'origine fixées au véhicule.
- Remarque 1: Dans certains cas, le panneau central peut nécessiter certaines modifications (recoupe, limado, etc.).
- Remarque 2: Si un crochet du support de montage interfère avec l'unité, pliez et aplânez-le avec une alicette ou un outil similaire.

- \* Las piezas y tornillos con esta marca se utilizan para instalar la radio o se suministran con el juego de instalación.
- \* Los tornillos con esta marca están originalmente fijados a los automóviles.
- Note 1: En algunos casos, el panel central puede requerir ciertas modificaciones (recorte, limado, etc.).
- Note 2: Si algún gancho del soporte de montaje interfiere con la unidad, dóblelo y aplánalo con unos alicates u otra herramienta similar.

English Français Español

## 4. REMOVAL OF THE SOURCE UNIT / DEPOSE DE L'APPAREIL PILOTE / DESMONTAJE DE LA UNIDAD FUENTE

1. When removing the source unit, disassemble it in the reverse of the order in Section "3. INSTALLING THE SOURCE UNIT".
2. Remove the Detachable Control Panel (DCP).
  - \* For instructions on removing the DCP, refer to the owner's manual.
3. Press the outer escutcheon upward and remove it. (Figure 8)
4. Insert and lock the hook plates. (Figure 9)
5. Pull the hook plates to remove the source unit.

1. Lors du dépose de l'appareil pilote, procédez dans l'ordre inverse de la Section "3. INSTALLATION DE L'APPAREIL PILOTE".
2. Démontez le panneau de commande détachable (DCP).
  - \* Pour les instructions sur le retrait du panneau de commande détachable (DCP), consultez le manuel de l'utilisateur.
3. Poussez l'écusson extérieur vers le haut et retirez-le. (Figure 8)
4. Insérez et bloquez les plaques à crochet. (Figure 9)
5. Tirez sur les plaques à crochet pour extraire l'appareil pilote.

1. Para desmontar la unidad fuente, realice el procedimiento inverso al de la Sección "3. INSTALACIÓN DE LA UNIDAD FUENTE".
2. Desmonte el panel de control desmontable (DCP).
  - \* Para instrucciones sobre como desmontar el DCP, consulte el manual de instrucciones.
3. Presione la pieza ornamental exterior hacia afuera y extraígalas. (Figura 8)
4. Inserte y bloquee las placas de enganche. (Figura 9)
5. Tire de las placas de enganche para extraer la unidad fuente.

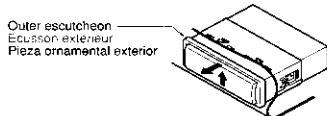

Figure 8 / Figure 8 / Figura 8

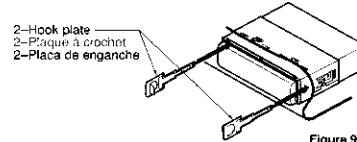

Figure 9 / Figure 9 / Figura 9

English Français Español

## 5. CAUTIONS ON WIRING / PRÉCAUTIONS AU SUJET DES CONNEXIONS / PRECAUCIONES PARA LA CONEXIÓN DE CABLES

1. Be sure to turn the power off when wiring.
2. Be particularly careful where you route the wires. Keep them well away from the engine, exhaust pipe, etc. Heat may damage the wires.
3. If the fuse should blow, check that the wiring is correct. If it is, replace the fuse with a new one with the same amperage rating as the original one. (Figure 10)

Note: There are various types of fuse holder. Do not let the battery side touch other metal parts.

4. Connect the CeNET extension cable fully and securely until it locks. When the CeNET extension cable is pulled, hold the side cap part and pull it towards you.
  - \* When the CeNET extension cable is extended or branched, use extension cable CCA-520 (2.5m) or CCA-521 (0.6m), or Y-adapter CCA-519 (each of them is sold separately).
  - \* Use the CeNET extension cable made by Clarion.
5. When the main power supply fuse in the car is 15 A or less, purchase an automotive cable that can withstand 15 A and supply the unit with power directly from the battery to ensure that the unit will operate normally. Note that a fuse must be installed at a distance no longer than 30 cm from the cable battery terminal to prevent accidents.

1. Toujours éteindre l'appareil lors de la câblage.
2. Soyez particulièrement prudent où vous routez les fils. Gardez-les bien éloignés du moteur, du tuyau d'échappement, etc. La chaleur peut endommager les fils.
3. Si le fusible saute, vérifiez que le câblage est correct. Si c'est le cas, remplacez le fusible par un fil du même calibre et de même ampérage que l'original. (Figure 10)

Remarque: Il existe différents types de porte-fusibles. Ne laissez pas le côté de la batterie toucher d'autres parties métalliques.

4. Connectez complètement et fermement le câble prolongateur CeNET jusqu'à ce qu'il se verrouille. Lorsque le câble prolongateur CeNET est tiré, tenez la partie de la capot latérale et tirez-la vers vous.
  - \* Lorsque le câble prolongateur CeNET est étendu ou branché, utilisez le câble prolongateur CCA-520 (2,5 m) ou CCA-521 (0,6 m) ou l'adaptateur Y CCA-519 (chacun d'eux est vendu séparément).
  - \* Utilisez le câble prolongateur CeNET fabriqué par Clarion.
5. Lorsque le fusible de l'alimentation principale du véhicule est de 15 A ou moins, achetez un câble automobile capable de résister à 15 A et alimentez l'unité directement à partir de la batterie pour garantir que l'unité fonctionnera normalement. Notez qu'un fusible doit être installé à une distance n'excédant pas 30 cm de la borne de la batterie pour éviter les accidents.

1. Antes de hacer las conexiones, asegúrese de desconectar la alimentación de la unidad.
2. Sea especialmente cuidadoso al dirigir y fijar los cables, manténgalos alejados del motor, tubo de escape, etc. El calor puede dañar los cables.
3. Si el fusible se quema, revise las conexiones. Si está quemado, reemplácelo el fusible por otro nuevo con el mismo valor de amperaje que el original. (Figura 10)

Note: Existen varios tipos de portafusibles. No permita que el terminal del lado de la batería toque otras partes metálicas.

4. Conecte el cable prolongador CeNET completa y seguramente hasta que chasquee. Para desconectar el cable, sujete la parte de la tapa deslizable y tire hacia usted.
  - \* Para prolongar o ramificar el cable prolongador CeNET, utilice un cable prolongador CCA-520 (2.5 m) o CCA-521 (0.6 m), o un adaptador en Y CCA-519 (vendidos aparte).
  - \* Utilice un cable prolongador CeNET fabricado por Clarion.
5. Cuando el fusible de alimentación principal del automóvil sea de 15 A o menos, adquiera un cable para automóvil que pueda resistir 15 A y alimente esta unidad directamente desde la batería para cerciorarse de que pueda funcionar normalmente. Tenga en cuenta que para evitar accidentes, deberá instalar un fusible en el cable que va a terminales de la batería a una distancia no superior a 30 cm.



Figure 10 / Figure 10 / Figura 10



# 6. WIRE CONNECTIONS / CONNECTIQUE / CONEXIÓN DE CABLES

**To external amplifier**  
 \* To eliminate audio short circuits, do not remove the caps of unused RCA cables.  
**CAUTION: Please make sure when connecting external power amplifier, that you properly, to the car chassis, ground the amplifier. If this is not done, severe damage to the source unit may happen.**

**Vers un amplificateur externe**  
 \* Pour supprimer les courts-circuits audio, ne pas retirer les capuchons des câbles RCA non utilisés.  
**ATTENTION: Lorsque vous raccordez un amplificateur externe, faites bien attention à mettre correctement l'amplificateur à la masse sur le châssis de la voiture. Sinon, vous risquez d'endommager gravement l'appareil pilote.**

**A un amplificador externo**  
 \* Para eliminar los cortocircuitos de audio, no quite los casquillos protectores de los cables RCA no utilizados.  
**PRECAUCIÓN: Cuando conecte un amplificador de potencia externo, cerciórese de ponerlo adecuadamente a masa en el chasis de su automóvil. Si no lo hiciera, la unidad fuente podría dañarse seriamente.**

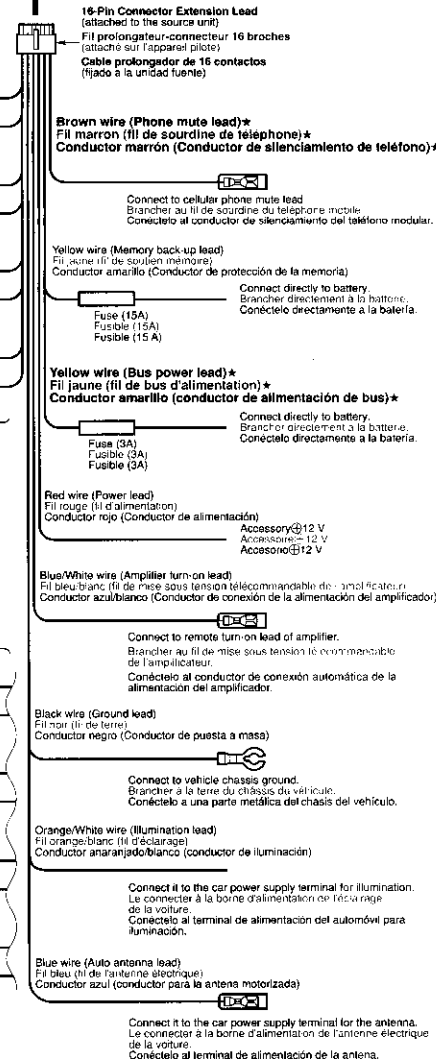
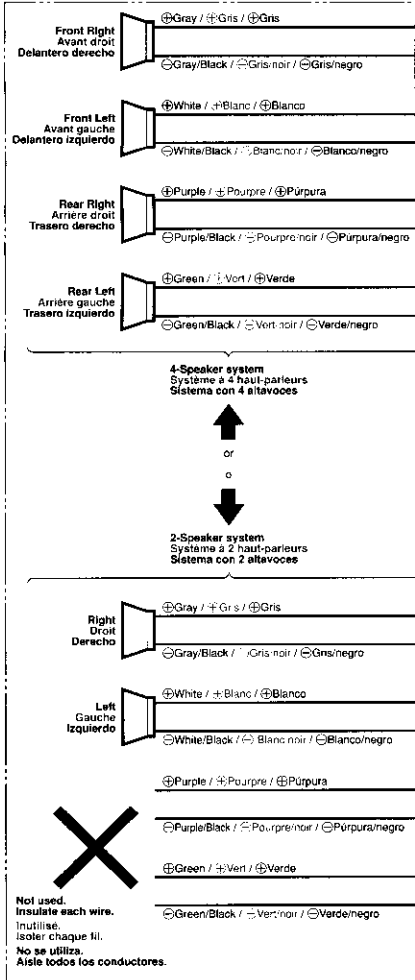
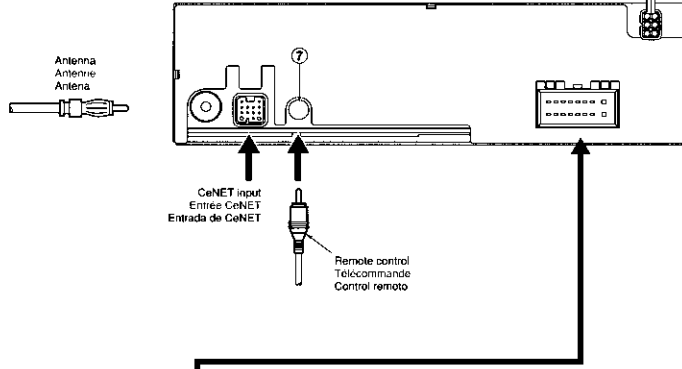
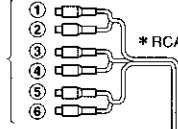

**Note:**  
 Some units do not have connecting leads or jacks.  
 (Refer to \*.)

**Remarque:**  
 Certains appareils n'ont pas de conducteurs de connexion ni de prises.  
 Voir \*.

**Nota:**  
 Algunas unidades no tienen cables de conexión ni conectores.  
 (Refiérase a \*.)

**English**

No.	Description
①	REAR RIGHT Black (Red)
②	REAR LEFT Black (White)
③	FRONT RIGHT Gray (Red)
④	FRONT LEFT Gray (White)
⑤	SUB WOOFER RIGHT Purple (Red)
⑥	SUB WOOFER LEFT Purple (White)
⑦	OEM STEERING WHEEL REMOTE CONTROL INPUT JACK (Black)

**Français**

No.	Description
①	ARRIÈRE DROITE Noir (Rouge)
②	ARRIÈRE GAUCHE Noir (Blanc)
③	AVANT DROITE Gris (Rouge)
④	AVANT GAUCHE Gris (Blanc)
⑤	BOSSONNE DE SUBGRAVES DROITE Pourpre (Rouge)
⑥	BOSSONNE DE SUBGRAVES GAUCHE Pourpre (Blanc)
⑦	PRISE D'ENTRÉE DE LA TÉLÉCOMMANDE SUR VOLANT OEM (Noir)

**Español**

No.	Descripción
①	TRASERO DERECHO Negro (Rojo)
②	TRASERO IZQUIERDO Negro (Blanco)
③	DELANTERO DERECHO Gris (Rojo)
④	DELANTERO IZQUIERDO Gris (Blanco)
⑤	ALTAVOZ DE SUBGRAVES DERECHO Púrpura (Rojo)
⑥	ALTAVOZ DE SUBGRAVES IZQUIERDO Púrpura (Blanco)
⑦	TOMA DE ENTRADA DE CONTROL REMOTO PARA EL VOLANTE OEM (Negro)

## 7. SYSTEM EXAMPLE/EXEMPLE DE SYSTEME/EJEMPLO DE SISTEMA

- Example of the system using an external amplifier (Audio Visual)
- Exemple de système utilisant un amplificateur extérieur. (audio-visuel)
- Ejemplo de sistema utilizando un amplificador externo (audiovisual)

- Example of AUX Bluetooth BB connection
- Exemple de connexion AUX Bluetooth BB
- Ejemplo de conexión de AUX Bluetooth BB

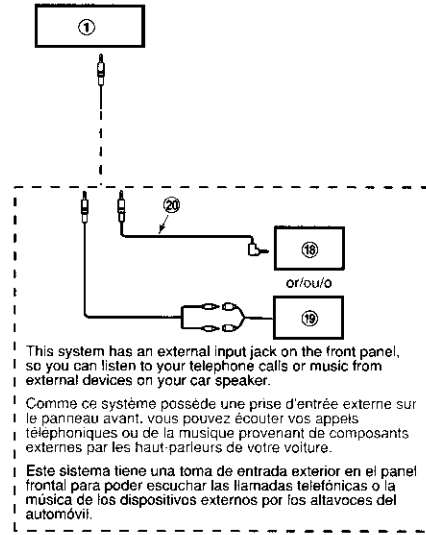
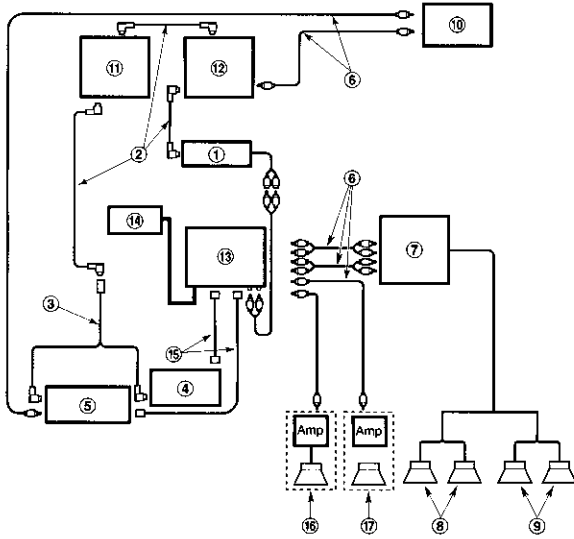

This system has an external input jack on the front panel, so you can listen to your telephone calls or music from external devices on your car speaker.

Comme ce système possède une prise d'entrée externe sur le panneau avant, vous pouvez écouter vos appels téléphoniques ou de la musique provenant de composants externes par les haut-parleurs de votre voiture.

Este sistema tiene una toma de entrada exterior en el panel frontal para poder escuchar las llamadas telefónicas o la música de los dispositivos externos por los altavoces del automóvil.

English

①	Main unit
②	CeNET extension cable
③	Y-adaptor (sold separately)
④	CD changer
⑤	DVD changer
⑥	RCA extension cable (sold separately)
⑦	Power amplifier (2- or 4-Channel)
⑧	Front speakers
⑨	Rear speakers
⑩	Monitor
⑪	Satellite radio receiver
⑫	TV tuner module
⑬	5.1ch surround decoder
⑭	5.1ch surround decoder control unit
⑮	Optical connector cable
⑯	Center speaker (with amplifier)
⑰	Subwoofer (with amplifier)
⑱	External unit
⑲	Aux Bluetooth BB (BLT370)
⑳	Stereo mini-plug cable (sold separately)

Français

①	Module principal
②	Câble rallonge CeNET
③	Adaptateur Y (vendu séparément)
④	Changeur de CD
⑤	Changeur de DVD
⑥	Câble de rallonge RCA (vendu séparément)
⑦	Amplificateur de puissance (2- ou 4- canaux)
⑧	Haut-parleurs avant
⑨	Haut-parleurs arrière
⑩	Moniteur
⑪	Récepteur radio satellite
⑫	Module Tuner TV
⑬	Décodeur surround 5.1 voies
⑭	Unité de contrôle de décodeur surround 5.1 voies
⑮	Câble de connexion optique
⑯	Haut-parleur central (avec amplificateur)
⑰	Casson de graves (avec amplificateur)
⑱	Unité externe
⑲	Aux Bluetooth BB (BLT370)
⑳	Câble stéréo à mini-fiche (vendu séparément)

Español

①	Unidad principal
②	Cable prolongador CeNET
③	Adaptador en Y (vendido aparte)
④	Cambiador de discos compactos
⑤	Cambiador de DVD
⑥	Cable de extensión RCA
⑦	Amplificador de potencia (2 ó 4 canales)
⑧	Altavoces delanteros
⑨	Altavoces traseros
⑩	Monitor
⑪	Receptor de radio vía satélite
⑫	Módulo sintonizador de televisión
⑬	Decodificador de sonido envolvente Surround de 5.1 canales
⑭	Unidad de control del decodificador de sonido envolvente Surround de 5.1 canales
⑮	Cable con conector óptico
⑯	Altavoz central (con amplificador)
⑰	Altavoz de subgraves (con amplificador)
⑱	Unidad externa
⑲	Bluetooth BB auxiliar (BLT370)
⑳	Cable de miniclavija estéreo (vendido por separado)

English Français Español

## 8. GENERAL CAUTIONS / PRÉCAUTIONS GÉNÉRALES / PRECAUCIONES GENERALES

- Do not open the case. There are no user serviceable parts inside. If you drop anything into the unit during installation, consult your dealer or an authorized CLARION service center.
- Use a soft, dry cloth to clean the case. Never use hard cloth, thinner, benzene, alcohol, etc. For tough dirt, apply a little cold or warm water to a soft cloth and wipe off the dirt gently.

- Ne pas ouvrir le coffret. Il n'y a pas de pièces réparables par l'utilisateur à l'intérieur de l'appareil. Si un objet est tombé dans l'appareil pendant l'installation, consulter votre revendeur ou un service après-vente agréé CLARION.
- Utiliser un chiffon doux et sec pour nettoyer le coffret. ne jamais utiliser un chiffon rigide, un diluant, du benzène, de l'alcool, etc. Pour enlever la saleté tenace, appliquer un peu d'eau froide ou tiède sur un chiffon doux et essuyer doucement la saleté.

- No abra la caja. En el interior no hay piezas que pueda reparar el usuario. Si dentro de la unidad entra algo durante la instalación, consulte a su proveedor o a un centro de servicio autorizado por CLARION.
- Para limpiar la caja, utilice un paño suave y seco. no use nunca un paño duro, diluidor de pintura, benceno, alcohol, etc. Para la suciedad resistente, aplique un poco de agua fría o caliente a un paño suave y frote suavemente la parte sucia.

**IMPORTANT:**  
Improper installation may cause damage to your unit or car. If you do not have the appropriate experience, consult a qualified installer. Cutting chassis wire leads voids the warranty.

**IMPORTANT:**  
Une installation incorrecte peut endommager l'appareil ou le véhicule. Si l'on ne possède pas les connaissances requises, consulter un installateur qualifié. Couper le fil du châssis annule la garantie.

**IMPORTANTE:**  
La instalación inapropiada puede causar daños en su unidad o su automóvil. Si usted no posee la experiencia apropiada, consulte a un instalador cualificado. El corte de los conductores de puesta a masa (carrocería) anulará la garantía.

**Clarion****GARANTIE LIMITÉE DE 1 AN CLARION**

Pour le Canada et les États-Unis seulement

Ce produit Clarion vendu par marchand autorisé Clarion est garanti contre tous défauts de matériel et de mise en œuvre pour une durée de **un (1) an** à compter de la date de vente initiale quand l'achat **ET** l'installation ont été effectués chez un marchand autorisé Clarion.

Tous câblages, fils et autres accessoires Clarion achetés chez un marchand autorisé Clarion, sont garantis contre tous défauts de matériel et de mise en œuvre pour une durée de quatre-vingt-dix (90) jours de la date d'achat initiale.

**TOUT ACHAT DE PRODUITS CLARION EFFECTUÉ CHEZ UN MARCHAND NON-AUTORISÉ CLARION SERA SOUMIS À DES RESTRICTIONS DE GRANANTIES DÉCRI CI-DESOUS.**

Les conditions de cette garantie limitée et l'implication de la responsabilité de Clarion Corporation of America "Clarion" sous cette garantie limitée sont les suivantes:

1. **DANS LE CAS DE LA GARANTIE LIMITÉE DE UN (1) AN, UNE PREUVE D'ACHAT ET UNE PREUVE D'INSTALLATION SONT REQUISES. DES INFORMATIONS SUPPLÉMENTAIRES CONCERNANT LES CENTRES DES SERVICES AUTORISÉS PAR CLARION PEUVENT ÊTRE OBTENUES AUX ADRESSES À LA FIN DE CE DOCUMENT.**
2. Cette Garantie Limitée sera annulée si un dommage est survenu au bien lors d'un service effectué par personne ou entreprise qui n'est pas accrédité comme un Centre de Service et Garantie Clarion.
3. Cette Garantie Limitée n'est pas applicable à un aucun produit sujet à l'abus, négligence, accidentés, installation ou utilisation incorrects ou que les numéros de série ont été modifiés, obstrué ou effacé, ou qui a été raccordés, installés, ajustés ou réparés autrement indiqué par Clarion.
4. Cette Garantie Limitée ne couvre pas des interférences électrostatiques, électriques, ni les ajustements ou nettoyage de la tête de lecture (en cas de radio cassette) ou éléments laser, ni les frais reliés à la manutention pour le retrait ou la réinstallation
5. La responsabilité de Clarion sous cette Garantie Limitée est limitée uniquement à la réparation ou au remplacement du produit, qui est sujet uniquement à la discrétion de Clarion.
6. Ce produit doit est livrée dans son emballage d'origine ou équivalent. Le colis doit être entièrement assuré et tous frais de transport doivent être prépayés. Clarion n'assumera aucune responsabilité en cas de perte ou dommages survenue lors du transport.
7. **TOUS PRODUITS CLARION ACQUIS PAR UNE ENTREMISE AUTRE QU'UN MARCHAND AUTORISÉ PAR CLARION, INCLUANT TOUS ACHATS VIA UN MARCHAND VIRTUEL (ACHAT INTERNET) QUI N'EST PAS AUTORISÉ PAR CLARION, NE SONT PAS COUVERTS PAR LES GARANTIES LIMITÉES DE CLARION, ET CE, EN ACCORD AVEC LES LIMITATIONS DÉFINIES PAR LA LOI. DANS LE CAS OÙ LES LOIS APPLICABLES NE PERMETTENT PAS L'ÉLIMINATION DES GARANTIES SOUS CES CONDITIONS, LA PÉRIODE DE GARANTIE LIMITÉE QUI S'APPLIQUE AU PRODUIT SERA DE QUINZE (15) JOURS À PARTIR DE LA DATE D'ACHAT INITIALE.**
8. **AUCUNE GARANTIE IMPLICITE NE POURRA S'ÉTENDRE AU-DELÀ DE LA PÉRIODE DE GARANTIE DÉCRITE CI-DESSUS, ET CE, EN ACCORD AVEC LES LIMITES DÉFINIES PAR LA LOI. CLARION NE POURRA EN AUCUN CAS ÊTRE TENUE RESPONSABLE DES PERMETS OU DOMMAGES DIRECTS OU INDIRECTS DU À L'UTILISATION OU L'IMPOSSIBILITÉ D'AUTILISATON DU PRODUIT. PUISQUE CERTAINS ÉTATS NE PERMETTENT PAS DE LIMITER LA DURÉE DES GARANTIES IMPLICITES, OU DE LIMITER LA RESPONSABILITÉ EN CAS DE DOMMAGES DIRECTS OU INDIRECTS, CES LIMITATIONS OU EXCLUSIONS PEUVENT NE PAS S'APPLIQUER À VOUS.**
9. **CETTE GARANTIE LIMITÉE VOUS DONNE DES DROITS LÉGAUX PRÉCIS. VOUS POUVEZ POSSÉDER DES DROITS SUPPLÉMENTAIRES SELON VOTRE LIEU DE RÉSIDENCE.**
10. Les lois de l'état de la Californie contrôlent totalement cette garantie limitée, son interprétation et sa mise en exécution.
11. Si vous éprouvez des problèmes de performance du produit pendant la période de garantie, veuillez communiquer avec Clarion ou visitez notre site Web à l'adresse ci-dessous afin d'obtenir une résolution de tout problème relié aux produits Clarion.

Aux États-Unis:  
Clarion Corporation of America  
Attn:Customer Service Manager  
6200 Gateway Drive Cypress, CA 90630  
1-800-GO-CLARION  
www.clarion.com

Au In Canada:  
Clarion Canada Inc.  
Centre de Service et Garantie  
2239 Winston Park Drive Oakville,  
Ontario L6H 5R1 (905)829-4600  
www.clarion.com

**clarion****CLARION 1 YEAR LIMITED WARRANTY**

For USA and Canada only

This Clarion product purchased from an authorized Clarion dealer are warranted against all defects in materials and workmanship for a period of **one (1) year** from the date of original purchase, when purchased from **AND** installed by an authorized Clarion dealer.

All Clarion cables, wires and other accessories if purchased from an authorized Clarion dealer are warranted against all defects in materials and workmanship for ninety (90) days from the date of original purchase.

**ALL PURCHASES OF CLARION PRODUCTS FROM NON-AUTHORIZED CLARION DEALERS ARE SUBJECT TO FURTHER WARRANTY RESTRICTIONS AS DESCRIBED BELOW.**

The conditions of this Limited Warranty and the extent of responsibility of Clarion Corporation of America ("Clarion") under this Limited Warranty are as follows :

1. **PROOF OF DATE OF PURCHASE FROM AN AUTHORIZED CLARION DEALER WILL BE REQUIRED FOR WARRANTY SERVICE OF THIS PRODUCT. CENTERS MAY BE OBTAINED BY CONTACTING CLARION AT THE ADDRESS LISTED BELOW.**
2. This Limited Warranty will become void if service performed by anyone other than an approved Clarion Warranty Service Center results in damage to the product.
3. This Limited Warranty does not apply to any product which has been subject to misuse, neglect or accident, or which has had the serial number altered, defaced or removed, or which has been connected, installed, adjusted or repaired, other than in accordance with the instructions furnished by Clarion.
4. This Limited Warranty does not cover car static or other electrical interferences, tape head or laser pick-up cleaning or adjustments, or labor costs for the removal or reinstallation of the unit for repair.
5. The sole responsibility of Clarion under this Limited Warranty shall be limited to the repair of the product or replacement of the product, at the sole discretion of Clarion.
6. Product must be shipped in its original carton or equivalent carton, fully insured, with shipping charges prepaid. Clarion will not assume any responsibility for any loss or damage incurred in shipping.
7. **CLARION PRODUCTS PURCHASED FROM A SOURCE OTHER THAN AN AUTHORIZED CLARION DEALER, INCLUDING ANY AND ALL PURCHASES VIA THE INTERNET FROM A NON INTERNET AUTHORIZED CLARION DEALER, SHALL NOT BE COVERED BY ANY CLARION LIMITED WARRANTY TO THE EXTENT ALLOWED BY APPLICABLE LAW. IN THE EVENT AND TO THE EXTENT APPLICABLE LAW PROHIBITS ELIMINATION OF WARRANTIES UNDER THESE CIRCUMSTANCES, THE APPLICABLE LIMITED WARRANTY PERIOD SHALL BE DEEMED TO BE FIFTEEN (15) DAYS FROM THE DATE OF ORIGINAL PURCHASE.**
8. **ALL IMPLIED WARRANTIES EXCEPT TO THE EXTENT PROHIBITED BY APPLICABLE LAW SHALL HAVE NO GREATER DURATION THAN THE WARRANTY PERIOD SET FORTH ABOVE. UNDER NO CIRCUMSTANCES SHALL CLARION BE LIABLE FOR ANY LOSS OR DAMAGE, DIRECT OR CONSEQUENTIAL, ARISING OUT OF THE USE OR INABILITY TO USE THE PRODUCT. BECAUSE SOME STATES DO NOT ALLOW LIMITATIONS ON HOW LONG AN IMPLIED WARRANTY LASTS OR EXCLUSIONS OR LIMITATIONS OF INCIDENTAL OR CONSEQUENTIAL DAMAGES, THE ABOVE LIMITATIONS OR EXCLUSIONS MAY NOT APPLY TO YOU.**
9. **THIS LIMITED WARRANTY GIVES YOU SPECIFIC LEGAL RIGHTS, AND YOU MAY ALSO HAVE OTHER RIGHTS WHICH VARY FROM STATE TO STATE.**
10. The laws of the State of California shall govern and control this Limited Warranty, its interpretation and enforcement.
11. Should you have any difficulties with the performance of this product during the warranty period, please call Clarion or visit our web site for a listing of Authorized Warranty Service Centers in your area. You may also contact Clarion Customer Service at the address listed below for any service help you may need with Clarion products.

In USA:  
Clarion Corporation of America  
Attn:Customer Service Manager  
6200 Gateway Drive  
Cypress, CA 90630  
1-800-GO-CLARION  
www.clarion.com

In Canada:  
Clarion Canada Inc.  
Warranty Service Center  
2239 Winston Park Drive  
Oakville, Ontario L6H 5R1  
(905) 829-4600  
www.clarion.com