

# Receiver Logic Board Assembly Replacement Instructions

## WARNING

To prevent possible SERIOUS INJURY or DEATH from electrocution, disconnect power to opener BEFORE proceeding.

## CAUTION

To prevent damage to the receiver/logic board, DO NOT touch printed circuit board of replacement receiver/logic board during installation.

### REPLACING THE ASSEMBLY

1. Disconnect power to opener.
2. *Figure 1.* Use a screwdriver tip to push in the terminal connector tabs on the back panel, and release the wires from the terminal block. Pull the wires through the opening above the terminal block and allow to rest on top of the motor unit.
3. *Figure 2.* Remove the opener lens and bulbs if applicable. To remove the lens press the release tabs (a) on both sides of lens. Gently rotate lens back and downward until the lens hinge is in the fully open position. Lift lens up slightly and remove.
4. Remove the four screws (b) located on receiver logic board panel.
5. Unplug the wire harnesses from the board. You may need needle-nosed pliers, or grasp the wires with thumb and forefinger and wiggle the harness free.
6. (Avoid touching the new printed circuit board). Plug both wire harnesses into the board on the new panel assembly, **taking care to seat them properly.**
7. Position and fasten new assembly.
8. *Figure 3.* Insert the door control wires into the terminal block by color: white wires into a white terminal, white/red wire into red.
9. Twist like colored wires together. Insert the safety sensor wires: white wire into a white terminal and white/black wire into grey. Reconnect power.

The opener needs to learn the code of all remotes in use. Instructions are on side two and in your owner's manual.

**NOTE: A TEST OF THE SAFETY REVERSE SYSTEM IS NECESSARY FOR SAFE OPERATION.** Instructions are on side two and in your opener's manual. OPEN and CLOSE force settings may also require adjustment. Refer to your owner's manual.

Figure 3

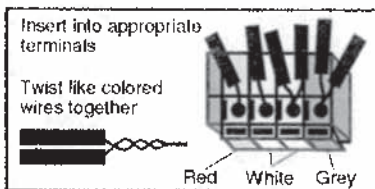

Figure 1

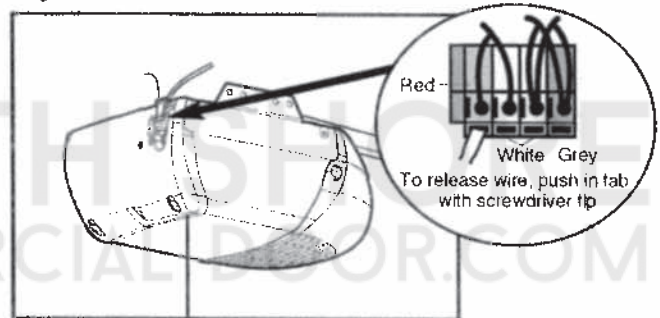
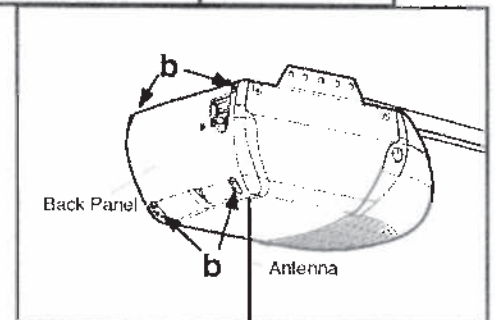
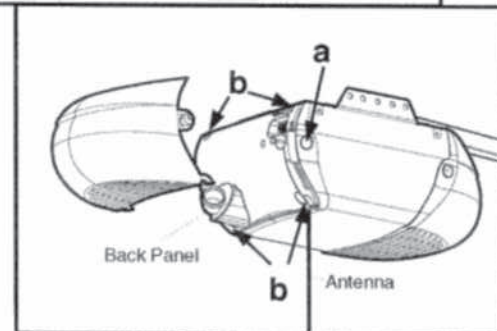
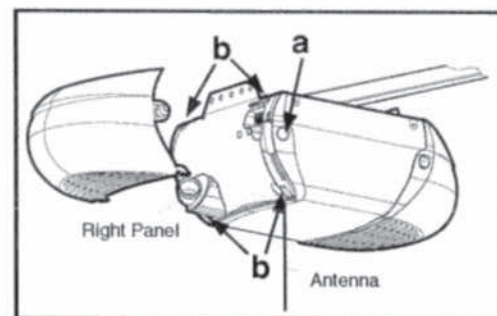
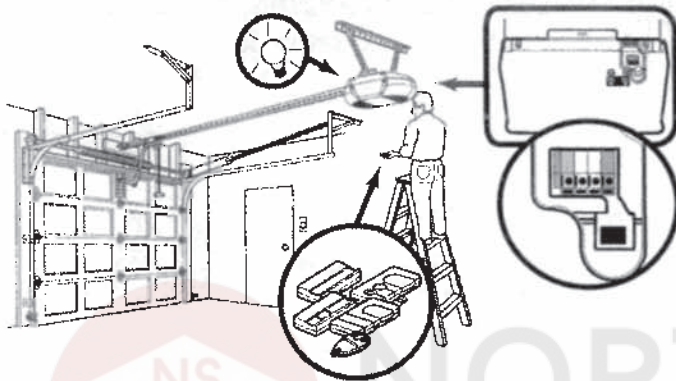

Figure 2



**PROGRAMMING THE OPENER TO ACCEPT THE HAND-HELD REMOTE CONTROL CODE**



1. Press and release the "learn" button on the motor unit. The learn indicator light will glow steadily for 30 seconds.
2. Within 30 seconds, press and hold the button on the hand-held remote that you wish to operate your garage door.
3. Release the button when the motor unit lights blink. It has learned the code. If light bulbs are not installed, two clicks will be heard.

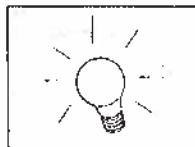
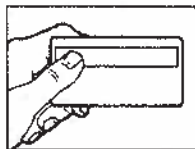

Repeat steps 1-3 for each remote control in use.

**NOTE:** If you use a keyless entry it must also be reprogrammed.

**TO ERASE ALL CODES FROM MOTOR UNIT MEMORY**

To deactivate any unwanted remote, first erase all codes:

Press and hold "learn" button on motor unit until the learn indicator light goes out (approximately 6 seconds). All previous codes are now erased. Reprogram each remote or keyless entry you wish to use.

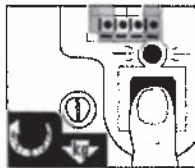

**NOTICE:** To comply with FCC and/or Industry Canada (IC) rules, adjustment or modifications of this receiver and/or transmitter are prohibited, except for changing the code setting or replacing the battery. THERE ARE NO OTHER USER SERVICEABLE PARTS.  
Tested to Comply with FCC Standards FOR HOME OR OFFICE USE. Operation is subject to the following two conditions: (1) this device may not cause harmful interference, and (2) this device must accept any interference received, including interference that may cause undesired operation.

**WARNING**

Without a properly installed safety reversal system, persons (particularly small children) could be SERIOUSLY INJURED or KILLED by a closing garage door.

- Safety reversal system **MUST** be tested every month.
- If one control (force or travel limits) is adjusted, the other control may also need adjustment.
- After ANY adjustments are made, the safety reversal system **MUST** be tested. Door **MUST** reverse on contact with 1-1/2" high (3.8 cm) object (or 2x4 laid flat) on the floor.

**CAUTION**

To prevent damage to vehicles, be sure fully open door provides adequate clearance.

**TEST THE SAFETY REVERSAL SYSTEM**

**TEST**

- With the door fully open, place a 1-1/2" (3.8 cm) board (or a 2x4 laid flat) on the floor, centered under the garage door.
- Operate the door in the down direction. The door **must** reverse on striking the obstruction.

**ADJUST**

- If the door stops on the obstruction, it is not traveling far enough in the down direction. Increase the DOWN limit by turning the DOWN limit adjustment screw counterclockwise 1/4 turn.

**NOTE:** On a sectional door, make sure limit adjustments do not force the door arm beyond a straight up and down position.

- Repeat the test.
- When the door reverses on the 1-1/2" (3.8 cm) board, remove the obstruction and run the opener through 3 or 4 complete travel cycles to test adjustment.
- If the unit continues to fail the Safety Reverse Test, call for a trained door systems technician.

**IMPORTANT SAFETY CHECK:**

Test the Safety Reverse System after:

- Each adjustment of door arm length, limits, or force controls.
- Any repair to or adjustment of the garage door (including springs and hardware).
- Any repair to or buckling of the garage floor.
- Any repair to or adjustment of the opener.

