

**SEARS**

M-56-04-876

# CRAFTSMAN®

**MODEL NUMBER 917.254850 OWNER'S MANUAL**



- **Assembly**
- **Operation**
- **Customer Responsibilities**
- **Service**
- **Adjustments**
- **Repair Parts**

**Caution:**  
**Read and Follow**  
**all Safety Rules**  
**and Instructions**  
**Before Operating**  
**This Equipment**

Sears, Roebuck and Co., Hoffman Estates, IL 60179 U.S.A.



# SAFETY RULES

## Safe Operation Practices for Ride-On Mowers



**IMPORTANT:** THIS CUTTING MACHINE IS CAPABLE OF AMPUTATING HANDS AND FEET AND THROWING OBJECTS. FAILURE TO OBSERVE THE FOLLOWING SAFETY INSTRUCTIONS COULD RESULT IN SERIOUS INJURY OR DEATH.

### I. GENERAL OPERATION

- Read, understand, and follow all instructions in the manual and on the machine before starting.
- Only allow responsible adults, who are familiar with the instructions, to operate the machine.
- Clear the area of objects such as rocks, toys, wire, etc., which could be picked up and thrown by the blade.
- Be sure the area is clear of other people before mowing. Stop machine if anyone enters the area.
- Never carry passengers.
- Do not mow in reverse unless absolutely necessary. Always look down and behind before and while backing.
- Be aware of the mower discharge direction and do not point it at anyone. Do not operate the mower without either the entire grass catcher or the guard in place.
- Slow down before turning.
- Never leave a running machine unattended. Always turn off blades, set parking brake, stop engine, and remove keys before dismounting.
- Turn off blades when not mowing.
- Stop engine before removing grass catcher or unclogging chute.
- Mow only in daylight or good artificial light.
- Do not operate the machine while under the influence of alcohol or drugs.
- Watch for traffic when operating near or crossing roadways.
- Use extra care when loading or unloading the machine into a trailer or truck.

### II. SLOPE OPERATION

Slopes are a major factor related to loss-of-control and tipover accidents, which can result in severe injury or death. All slopes require extra caution. If you cannot back up the slope or if you feel uneasy on it, do not mow it.

#### DO:

- Mow up and down slopes, not across.
- Remove obstacles such as rocks, tree limbs, etc.
- Watch for holes, ruts, or bumps. Uneven terrain could overturn the machine. *Tall grass can hide obstacles.*
- Use slow speed. Choose a low gear so that you will not have to stop or shift while on the slope.
- Follow the manufacturer's recommendations for wheel weights or counterweights to improve stability.
- Use extra care with grass catchers or other attachments. These can change the stability of the machine.
- Keep all movement on the slopes *slow and gradual*. Do not make sudden changes in speed or direction.
- Avoid starting or stopping on a slope. If tires lose traction, disengage the blades and proceed slowly *straight* down the slope.

#### DO NOT:

- *Do not* turn on slopes unless necessary, and then, turn slowly and gradually downhill, if possible.
- *Do not* mow near drop-offs, ditches, or embankments. The mower could suddenly turn over if a wheel is over the edge of a cliff or ditch, or if an edge caves in.
- *Do not* mow on wet grass. Reduced traction could cause sliding.
- *Do not* try to stabilize the machine by putting your foot on the ground.

- *Do not* use grass catcher on steep slopes.

### III. CHILDREN

Tragic accidents can occur if the operator is not alert to the presence of children. Children are often attracted to the machine and the mowing activity. *Never* assume that children will remain where you last saw them.

- Keep children out of the mowing area and under the watchful care of another responsible adult.
- Be alert and turn machine off if children enter the area.
- Before and when backing, look behind and *down* for small children.
- Never carry children. They may fall off and be seriously injured or interfere with safe machine operation.
- Never allow children to operate the machine.
- Use extra care when approaching blind corners, shrubs, trees, or other objects that may obscure vision.

### IV. SERVICE

- Use extra care in handling gasoline and other fuels. They are flammable and vapors are explosive.
  - Use only an approved container.
  - Never remove gas cap or add fuel with the engine running. Allow engine to cool before refueling. Do not smoke.
  - Never refuel the machine indoors.
  - Never store the machine or fuel container inside where there is an open flame, such as a water heater.
- Never run a machine inside a closed area.
- Keep nuts and bolts, especially blade attachment bolts, tight and keep equipment in good condition.
- Never tamper with safety devices. Check their proper operation regularly.
- Keep machine free of grass, leaves, or other debris build-up. Clean oil or fuel spillage. Allow machine to cool before storing.
- Stop and inspect the equipment if you strike an object. Repair, if necessary, before restarting.
- Never make adjustments or repairs with the engine running.
- Grass catcher components are subject to wear, damage, and deterioration, which could expose moving parts or allow objects to be thrown. Frequently check components and replace with manufacturer's recommended parts, when necessary.
- Mower blades are sharp and can cut. Wrap the blade(s) or wear gloves, and use extra caution when servicing them.
- Check brake operation frequently. Adjust and service as required.



Look for this symbol to point out important safety precautions. It means **CAUTION!!! BECOME ALERT!!! YOUR SAFETY IS INVOLVED.**



**CAUTION:** Always disconnect spark plug wire and place wire where it cannot contact spark plug in order to prevent accidental starting when setting up, transporting, adjusting or making repairs.

**CONGRATULATIONS** on your purchase of a Sears Tractor. It has been designed, engineered and manufactured to give you the best possible dependability and performance.

Should you experience any problem you cannot easily remedy, please contact your nearest Sears Service Center/Department. We have competent, well-trained technicians and the proper tools to service or repair this unit.

Please read and retain this manual. The instructions will enable you to assemble and maintain your unit properly. Always observe the "SAFETY RULES".

MODEL NUMBER	917.254850
SERIAL NUMBER	_____
DATE OF PURCHASE	_____
THE MODEL AND SERIAL NUMBERS WILL BE FOUND ON A PLATE UNDER THE SEAT.	
YOU SHOULD RECORD BOTH SERIAL NUMBER AND DATE OF PURCHASE AND KEEP IN A SAFE PLACE FOR FUTURE REFERENCE.	

## MAINTENANCE AGREEMENT

A Sears Maintenance Agreement is available on this product. Contact your nearest Sears store for details.

## CUSTOMER RESPONSIBILITIES

- Read and observe the safety rules.
- Follow a regular schedule in maintaining, caring for and using your unit.
- Follow the instructions under "Customer Responsibilities" and "Storage" sections of this owner's manual.

## PRODUCT SPECIFICATIONS

HORSEPOWER:	14
GASOLINE CAPACITY:	5 QUARTS UNLEADED REGULAR
OIL (3.5 PINTS W/O FILTER): (4.0 PINTS W/FILTER):	SAE 30 (Above 32°F) SAE 5W-30 (Below 32°F)
SPARK PLUG (GAP .030 IN.):	CHAMPION RC-12YC
VALVE CLEARANCE:	INTAKE .0015 - .0030 IN. EXHAUST .0020 - .0035 IN.
GROUND SPEED:	FORWARD 1st 1.10 MPH 2nd 1.40 MPH 3rd 2.00 MPH 4th 3.00 MPH 5th 4.20 MPH 6th 5.00 MPH REVERSE: 1.50 MPH
TIRE PRESSURE:	FRONT: 14 PSI REAR: 12 PSI
CHARGING SYSTEM:	3 AMPS BATTERY 5 AMPS HEADLIGHTS
BLADE BOLT TORQUE:	30-35 FT. LBS.

**WARNING:** This unit is equipped with an internal combustion engine and should not be used on or near any unimproved forest-covered, brush-covered or grass-covered land unless the engine's exhaust system is equipped with a spark arrester meeting applicable local or state laws (if any). If a spark arrester is used, it should be maintained in effective working order by the operator.

In the state of California the above is required by law (Section 4442 of the California Public Resources Code). Other states may have similar laws. Federal laws apply on federal lands. A spark arrester for the muffler is available through your nearest Sears Authorized Service Center (See REPAIR PARTS section of this manual).

## LIMITED TWO YEAR WARRANTY ON ELECTRIC START RIDING EQUIPMENT

For two (2) years from the date of purchase, if this riding equipment is maintained, lubricated and tuned up according to the instructions in the owner's manual, Sears will repair or replace, free of charge, any parts found to be defective in material or workmanship.

This Warranty does not cover:

- Expendable items which become worn during normal use, such as blades, spark plugs, air cleaners and belts.
- Tire replacement or repair caused by punctures from outside objects, such as nails, thorns, stumps, or glass.
- Repairs necessary because of operator abuse, negligence, improper storage or accident or the failure to maintain the equipment according to the instructions contained in the owner's manual.
- Riding equipment used for commercial or rental purposes.

## LIMITED 90 DAY WARRANTY ON BATTERY

For 90 days from date of purchase, if any battery included with this riding equipment proves defective in material or workmanship and our testing determines the battery will not hold a charge, Sears will replace the battery at no charge.

WARRANTY SERVICE IS AVAILABLE BY RETURNING THE RIDING EQUIPMENT TO THE NEAREST SEARS SERVICE CENTER/DEPARTMENT IN THE UNITED STATES.

This Warranty gives you specific legal rights, and you may also have other rights which may vary from state to state.

SEARS, ROEBUCK AND CO., D/817 WA, HOFFMAN ESTATES, ILLINOIS 60179

# TABLE OF CONTENTS

SAFETY RULES .....	2	OPERATION .....	11-14
PRODUCT SPECIFICATIONS .....	3	MAINTENANCE SCHEDULE .....	15
CUSTOMER RESPONSIBILITIES .....	3, 15-19	SERVICE AND ADJUSTMENTS .....	20-25
WARRANTY .....	3	STORAGE .....	26
TABLE OF CONTENTS .....	4	TROUBLESHOOTING .....	27-28
INDEX .....	4	REPAIR PARTS - TRACTOR .....	30-47
TRACTOR ACCESSORIES .....	5	REPAIR PARTS - ENGINE .....	48-53
ASSEMBLY .....	7-10	PARTS ORDERING/SERVICE .....	BACK PAGE







## INDEX

<p style="text-align: center;"><b>A</b></p> <p>Accessories.....5</p> <p>Adjustments:</p> <p style="padding-left: 20px;">Brake.....22</p> <p style="padding-left: 20px;">Carburetor.....25</p> <p style="padding-left: 20px;">Mower</p> <p style="padding-left: 40px;">Front-To-Back.....21</p> <p style="padding-left: 40px;">Side-To-Side.....21</p> <p style="padding-left: 40px;">Throttle Control Cable.....25</p> <p>Air Filter, Engine.....18</p> <p>Air Screen, Engine.....18</p> <p>Assembly.....7-10</p> <p style="text-align: center;"><b>B</b></p> <p>Battery:</p> <p style="padding-left: 20px;">Charging.....8</p> <p style="padding-left: 20px;">Cleaning.....17</p> <p style="padding-left: 20px;">Installation.....9</p> <p style="padding-left: 20px;">Levels.....8,17</p> <p style="padding-left: 20px;">Preparation.....8</p> <p style="padding-left: 20px;">Starting with Weak Battery.....23</p> <p style="padding-left: 20px;">Storage.....26</p> <p style="padding-left: 20px;">Terminals.....17</p> <p>Belt:</p> <p style="padding-left: 20px;">Motion Drive</p> <p style="padding-left: 40px;">Removal/Replacement.....22</p> <p style="padding-left: 20px;">Mower Blade Drive</p> <p style="padding-left: 40px;">Removal/Replacement.....22</p> <p>Blade:</p> <p style="padding-left: 20px;">Sharpening.....16</p> <p style="padding-left: 20px;">Replacement.....16</p> <p>Brake Adjustment.....22</p> <p style="text-align: center;"><b>C</b></p> <p>Carburetor Adjustment.....25</p> <p>Controls, Tractor.....11</p> <p>Customer Responsibilities.....15-19</p> <p>Engine:</p> <p style="padding-left: 20px;">Air Filter.....18</p> <p style="padding-left: 20px;">Air Screen, Engine.....18</p> <p style="padding-left: 20px;">Battery.....17</p> <p style="padding-left: 20px;">Cooling Fins, Engine.....18</p> <p style="padding-left: 20px;">Engine Oil.....17</p> <p style="padding-left: 20px;">Fuel Filter.....19</p> <p style="padding-left: 20px;">Spark Plugs.....19</p> <p>Tractor:</p> <p style="padding-left: 20px;">Blade.....16</p> <p style="padding-left: 20px;">Lubrication Chart.....15</p> <p style="padding-left: 20px;">Maintenance Schedule.....15</p> <p style="padding-left: 20px;">Tire Care.....8,16,23</p> <p>Cutting Height, Mower.....12</p>	<p style="text-align: center;"><b>E</b></p> <p>Electrical:</p> <p style="padding-left: 20px;">Interlocks and Relays.....24</p> <p style="padding-left: 20px;">Schematic.....29</p> <p style="padding-left: 20px;">Wiring Diagram.....30</p> <p>Engine:</p> <p style="padding-left: 20px;">Air Filter.....18</p> <p style="padding-left: 20px;">Air Screen.....18</p> <p style="padding-left: 20px;">Cooling Fins, Engine.....18</p> <p style="padding-left: 20px;">Oil Change.....17</p> <p style="padding-left: 20px;">Oil Level.....13,17</p> <p style="padding-left: 20px;">Oil Type.....17</p> <p style="padding-left: 20px;">Preparation.....13</p> <p style="padding-left: 20px;">Repair Parts.....48-53</p> <p style="padding-left: 20px;">Starting.....14</p> <p style="padding-left: 20px;">Storage.....26</p> <p style="text-align: center;"><b>F</b></p> <p>Filter:</p> <p style="padding-left: 20px;">Air Filter.....18</p> <p style="padding-left: 20px;">Fuel.....19</p> <p>Fuel:</p> <p style="padding-left: 20px;">Type.....13</p> <p style="padding-left: 20px;">Storage.....26</p> <p>Fuse.....24</p> <p style="text-align: center;"><b>H</b></p> <p>Hood Removal/Installation.....24</p> <p style="text-align: center;"><b>L</b></p> <p>Leveling Mower Deck.....21</p> <p>Lubrication:</p> <p style="padding-left: 20px;">Chart.....15</p> <p style="text-align: center;"><b>M</b></p> <p>Maintenance Schedule.....15</p> <p>Mower:</p> <p style="padding-left: 20px;">Adjustment, Front-to-Back.....21</p> <p style="padding-left: 20px;">Adjustment, Side-to-Side.....21</p> <p style="padding-left: 20px;">Blade Sharpening.....16</p> <p style="padding-left: 20px;">Blade Replacement.....16</p> <p style="padding-left: 20px;">Cutting Height.....12</p> <p style="padding-left: 20px;">Installation.....20</p> <p style="padding-left: 20px;">Operation.....13</p> <p style="padding-left: 20px;">Removal.....20</p> <p style="padding-left: 20px;">Mowing Tips.....14</p> <p>Muffler.....19</p> <p style="padding-left: 20px;">Spark Arrester.....3,40</p> <p>Mulcher Plate.....10</p> <p style="text-align: center;"><b>O</b></p> <p>Oil:</p> <p style="padding-left: 20px;">Cold Weather Conditions.....13,17</p> <p style="padding-left: 20px;">Engine.....17</p> <p style="padding-left: 20px;">Storage.....26</p>	<p>Operation.....11-14</p> <p>Operating Mower.....13</p> <p>Options:</p> <p style="padding-left: 20px;">Accessories.....5</p> <p style="padding-left: 20px;">Spark Arrester.....3,40</p> <p style="text-align: center;"><b>P</b></p> <p>Parking Brake.....11-12</p> <p>Parts Bag.....6</p> <p>Parts, Replacement/Repair.....30-47</p> <p>Product Specifications.....3</p> <p style="text-align: center;"><b>R</b></p> <p>Repair Parts.....30-47</p> <p style="text-align: center;"><b>S</b></p> <p>Safety Rules.....2</p> <p>Seat.....8</p> <p>Service and Adjustments.....20-25</p> <p style="padding-left: 20px;">Carburetor.....25</p> <p style="padding-left: 20px;">Fuse.....24</p> <p style="padding-left: 20px;">Hood Removal/Installation.....23</p> <p style="padding-left: 20px;">Motion Drive Belt</p> <p style="padding-left: 40px;">Removal/Replacement.....22</p> <p style="padding-left: 20px;">Mower Blade Drive Belt</p> <p style="padding-left: 40px;">Removal/Replacement.....22</p> <p style="padding-left: 20px;">Mower Adjustment</p> <p style="padding-left: 40px;">Front- to-Back.....21</p> <p style="padding-left: 40px;">Side-to-Side.....21</p> <p style="padding-left: 20px;">Mower Removal.....20</p> <p style="padding-left: 20px;">Tire Care.....8,16,23</p> <p>Slope Guide Sheet.....55</p> <p>Spark Plugs.....19</p> <p>Specifications.....3</p> <p>Starting the Engine.....13-14</p> <p>Steering Wheel.....7,23</p> <p>Stopping the Tractor.....12</p> <p>Storage.....26</p> <p style="text-align: center;"><b>T</b></p> <p>Throttle Control Cable</p> <p style="padding-left: 20px;">Adjustment.....25</p> <p>Tires.....8,16,23</p> <p>Trouble Shooting Chart.....27-28</p> <p>Transaxle:</p> <p style="padding-left: 20px;">Repair Parts.....46-47</p> <p style="text-align: center;"><b>W</b></p> <p>Warranty.....3</p> <p>Wiring Diagram.....30</p> <p>Wiring Schematic.....29</p>
---	---	---



# ACCESSORIES AND ATTACHMENTS

These accessories and attachments were available when the tractor was purchased. They are also available at most Sears retail outlets, catalog and service centers. Most Sears stores can order these items for you when you provide the model number of your tractor.

## ENGINE

SPARK PLUG	MUFFLER	AIR FILTER	GAS CAN	ENGINE OIL	STABILIZER
					

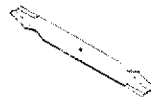
## MAINTENANCE

BLADES	BELTS
	

## PERFORMANCE

Sears offers a wide variety of attachments that fit your tractor. Many of these are listed below with brief explanations of how they can help you. This list was current at the time of publication; however, it may change in future years - more attachments may be added, changes may be made in these attachments, or some may no longer be available or fit your model. **Contact your nearest Sears store for the accessories and attachments that are available for your tractor.**

Most of these attachments do not require additional hitches or conversion kits (those that do are indicated) and are designed for easy attaching and detaching.

**PERMANEX BAGGER** lets you collect grass clippings and leaves for a healthier, neater looking lawn. Two Permanex containers hold 30-gallon plastic bags.

**LAWN SWEEPERS** let you collect grass clippings and leaves.

**LAWN VACS** for powerful collection of heavy grass clippings and leaves. Wand attachment to pick up debris in hard-to-reach places.

**CARTS** make hauling easy. Variety of sizes available.

**ROLLER** for smoother lawn surface. 36-inch wide, 18-inch diameter water-tight drum holds up to 390 lbs. of weight. Rounded edges prevent harm to turf. Adjustable scraper automatically cleans drum.

**SPREADER/SEEDERS** make seeding, fertilizing, and weed killing easy. Broadcast spreaders are also useful for granular de-icers and sand.

**CORING AERATOR** takes small plugs out of soil to allow moisture and nutrients to reach grass roots. 36-inch swath. 24 hardened steel coring tips. 150 lb. capacity weight tray.

**AERATOR** promotes deep root growth for a healthy lawn. Tapered 2.5-inch steel spikes mounted on 10-inch diameter discs puncture holes in soil at close intervals to let moisture soak in. Steel weight tray for increased penetration.

**MULCH RAKE/DETHATCHER** loosens soil and flips thatch and matted leaves to lawn surface for easy pickup. Twenty spring tine teeth. Useful to prepare bare areas for seeding. Available for front or rear mounting.

**SPRAYERS** use 12-volt DC electric motor that connects to the tractor battery or other 12-volt source. Includes booms for automatic spraying when pulling, and hand held wand for spot spraying. Wand has adjustable spray pattern. For applying herbicides, insecticides, fungicides, and liquid fertilizers.

**SNOW BLADE** for snow removal only. 14-inch high, 42-inch wide blade clears 38-inch path when angled left or right. Raises, lowers with side lever. Adjustable skids; replaceable, reversible scraper bar. (Use with tire chains, wheel weights, or rear drawbar weight.)

**SNOWTHROWER** has 40-inch swath. Drum-type auger handles powdery and wet/heavy snow. Mounts easily with simple pin arrangement. Discharge chute adjusts from tractor seat. 6-inch diameter spout discharges snow 10 to 50 feet. Lift controlled at tractor seat. (Use with chains, wheel weights, or rear drawbar weight.)

**TIRE CHAINS** are heavy duty; closely spaced extra-large cross links give smooth ride, outstanding traction.

**WHEEL WEIGHTS** for rear wheels provide needed traction for snow removal or dozing heavy materials. In pairs. (30 lbs. each.)

**TRACTOR CAB** has heavy duty vinyl fabric over tubular steel frame, ABS plastic top; clear plastic windshield offers 360 degree visibility. Hinged metal doors with catch. Keeps operator warm and dry. Remove vinyl and windshields for use as sun protector in summer. (Catalog only.)

**Optional accessories for tractor cab:** tinted/tempered solid safety glass windshield with hand operated wiper; 12-volt amber caution light for mounting on cab top. (Catalog only.)

**TRACTOR COVER** protects tractor from weather. Made of Evolution 3 fabric (water-repellent, extremely breathable, light weight, soft, non-abrasive, pliable in all temperatures, durable, stain/tear/puncture resistant, will not shrink or stretch.) (Catalog only.)

**TILLER** has 5 hp engine and 36-inch swath to prepare seed beds, cultivate, and compost garden residue. Tiller has its own built-in lift and depth control system and does NOT require a sleeve hitch. Fits any lawn, yard, or garden tractor. Simply hook up to the tractor drawbar and go!

# CONTENTS OF HARDWARE PACK

## Parts Bag contents shown full size

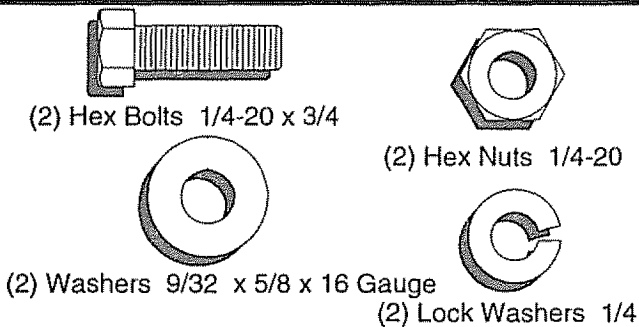
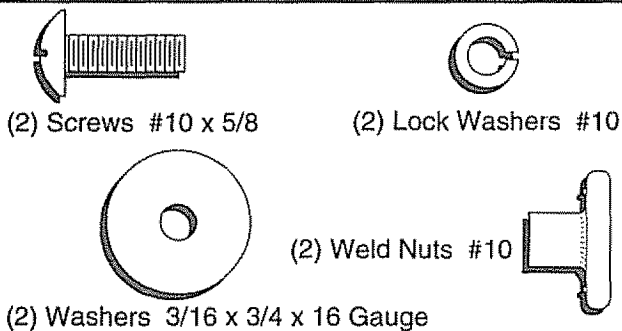
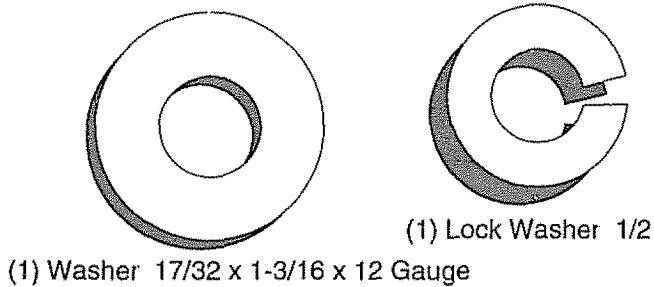
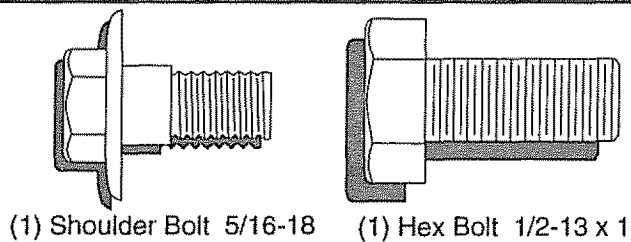
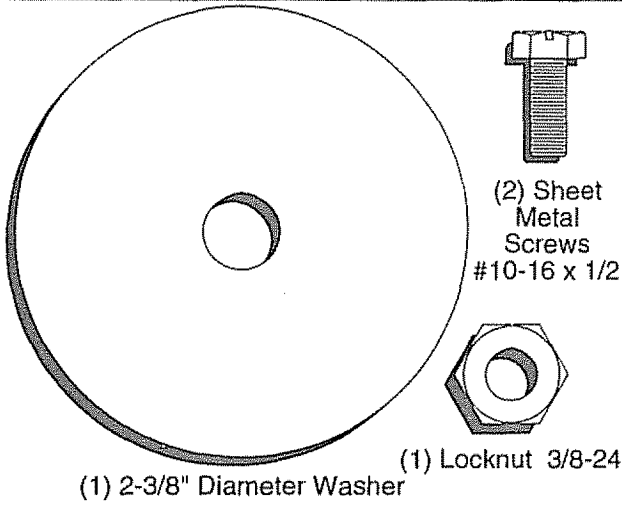

## Parts packed separately in carton

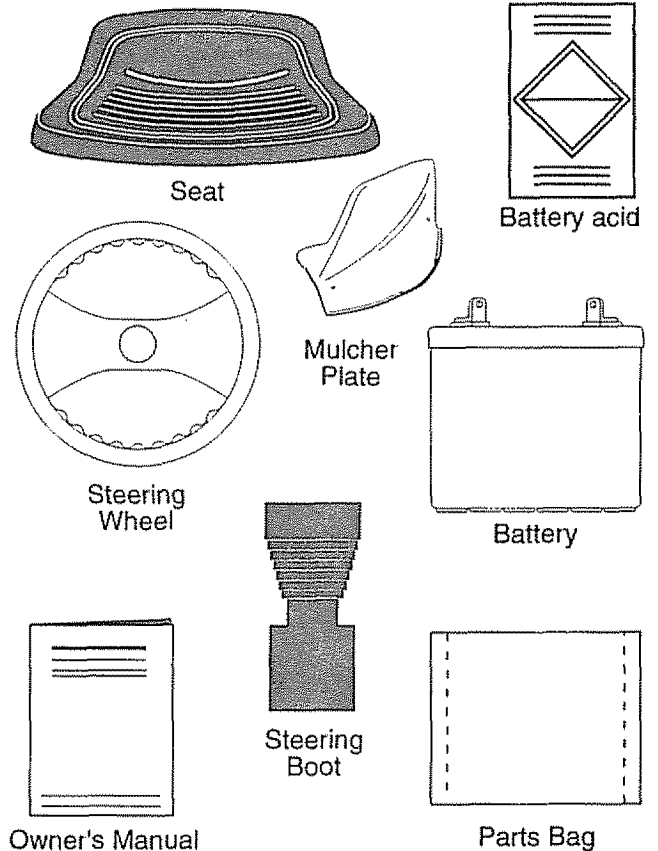

## Parts bag contents not shown full size

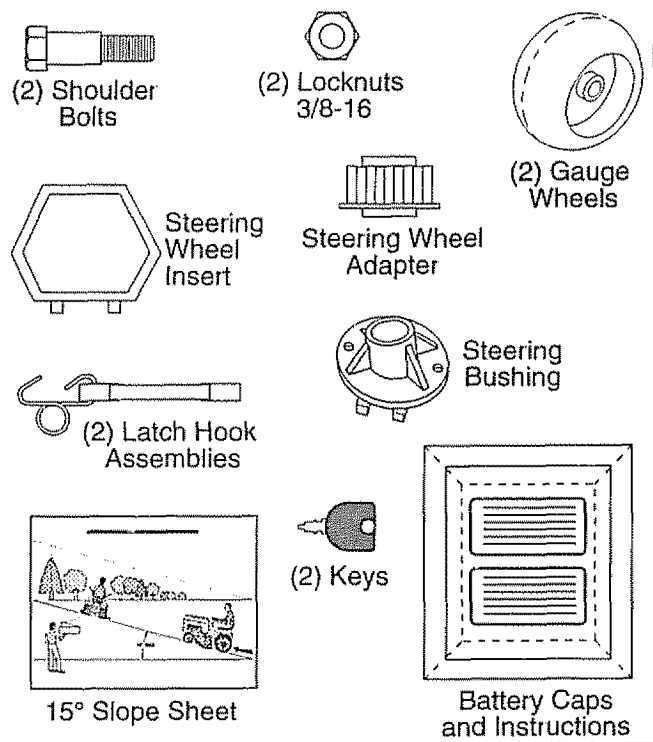

# ASSEMBLY

Your new tractor has been assembled at the factory with exception of those parts left unassembled for shipping purposes. To ensure safe and proper operation of your tractor all parts and hardware you assemble must be tightened securely. Use the correct tools as necessary to insure their proper tightness.

## TOOLS REQUIRED FOR ASSEMBLY

A socket wrench set will make assembly easier. Standard wrench sizes are listed.

- |                                 |                      |
|---------------------------------|----------------------|
| (1) 5/16" wrench                | Tire pressure gauge  |
| (2) 7/16" wrenches              | Phillips Screwdriver |
| (1) 9/16" wrench                | Utility knife        |
| (1) 3/4" socket & drive ratchet | (1) 1/2" wrench      |

When right and left hand is mentioned in this manual, it means when you are in the operating position (seated behind the steering wheel).

## TO REMOVE UNIT FROM CARTON

### UNPACK CARTON

- Remove all accessible loose parts and parts cartons from carton (See page 6).
- Cut along lines on carton, from top to bottom, all four corners of carton and lay panels flat.
- Check for any additional loose parts or cartons and remove.

## BEFORE ROLLING UNIT OFF SKID

### ATTACH STEERING WHEEL (See Fig. 1)

- Slide the steering bushing over the steering shaft.
- Raise steering shaft forward until screw holes in dash line up with steering bushing. Install two (2) sheet metal screws and tighten securely.
- Position steering boot over steering shaft.
- Align tabs of steering boot over slots and hole in dash and push down to secure.
- Slide steering wheel adapter onto upper steering shaft.
- Position front wheels of the tractor so they are pointing straight forward.
- Position steering wheel so cross bars are horizontal (left to right) and slide onto adapter.
- Assemble large flat washer and 3/8-24 hex locknut and tighten securely.
- Snap insert into center of steering wheel.
- Remove protective plastic from tractor hood and grill.

**IMPORTANT:** CHECK FOR AND REMOVE ANY STAPLES IN SKID THAT MAY PUNCTURE TIRES WHERE UNIT IS TO ROLL OFF SKID.

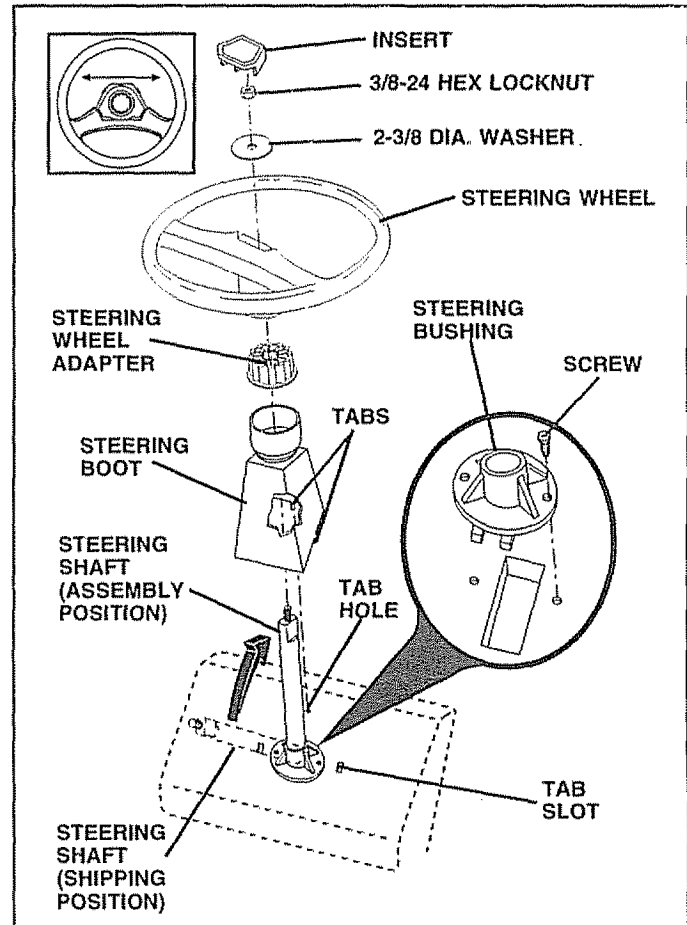

FIG. 1

### TO ROLL UNIT OFF SKID (See Fig. 8)

- Raise attachment lift lever to its highest position.
- Release parking brake by depressing clutch/brake pedal.
- Place gearshift lever in "NEUTRAL" position.
- Roll unit backwards off skid.
- Remove banding holding discharge guard up against tractor.

# ASSEMBLY

## HOW TO SET UP YOUR TRACTOR

### PREPARE BATTERY (See Fig. 2)



**CAUTION:** Wear eye and face shield. Wash hands or clothing immediately if accidentally in contact with battery acid. Do not smoke. Fumes from charged battery acid are explosive. Read the instructions included with the battery vent caps. Always wear gloves, clothing and goggles to protect your hands, skin and eyes.

Your unit has a battery charging system which is sufficient for normal use. However, periodic charging of the battery with an automotive charger will extend its life.

- See instructions packed with vent caps in parts bag.
- Fill battery with acid. Fill each cell until it reaches the bottom of the vent wells. Do not overfill.
- Allow battery to stand and settle for at least thirty minutes. After standing, check the level of acid. If below the vent wells, add more acid until the correct level is reached.

While battery is standing (after adding acid) and later, while battery is being charged, continue with assembly of unit.

**IMPORTANT:** TO MAXIMIZE THE LIFE OF YOUR BATTERY, IT IS NECESSARY THAT THE BATTERY BE CHARGED BEFORE USE. FAILURE TO CHARGE BATTERY CAN RESULT IN A SHORTENED BATTERY LIFE.

- Charge battery at a rate of 6 amperes for 1 hour. Use a 12 volt battery charger. Observe all safety precautions required for battery charging.
- Check the acid level after the battery is charged. If the acid has fallen below the correct level, add distilled or iron free water.
- Install the vent caps to cover the vent wells. Wash the top of the battery with water to remove any acid, then wipe dry.
- Check battery case for leakage to make sure that no damage has occurred in handling.
- Dispose of excess battery acid. Neutralize acid for disposal by adding it to four inches of water in a five gallon plastic container. Stir with a wooden or plastic paddle while adding baking soda until the addition of more soda causes no more foaming.
- Follow instructions on how to install battery.

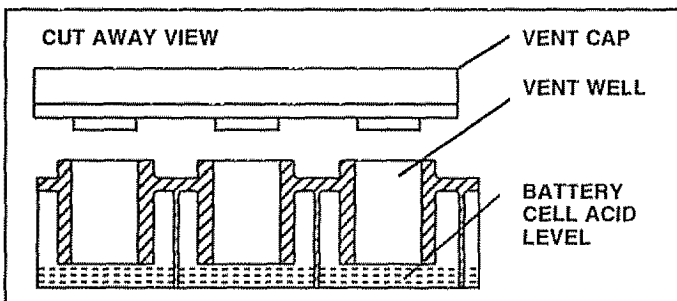

FIG. 2

### INSTALL SEAT (See Fig. 3)

Adjust seat before tightening adjustment bolt.

- Remove cardboard packing on seat pan.
- Place seat on pan and assemble shoulder bolt.
- Assemble adjustment bolt, lock washer and flat washer loosely. Do not tighten.
- Tighten shoulder bolt securely.
- Lower seat into operating position and sit on seat.
- Slide seat until a comfortable position is reached which allows you to press clutch/brake pedal all the way down (See Fig. 8).
- Get off seat without moving its adjusted position.
- Raise seat and tighten adjustment bolt securely.

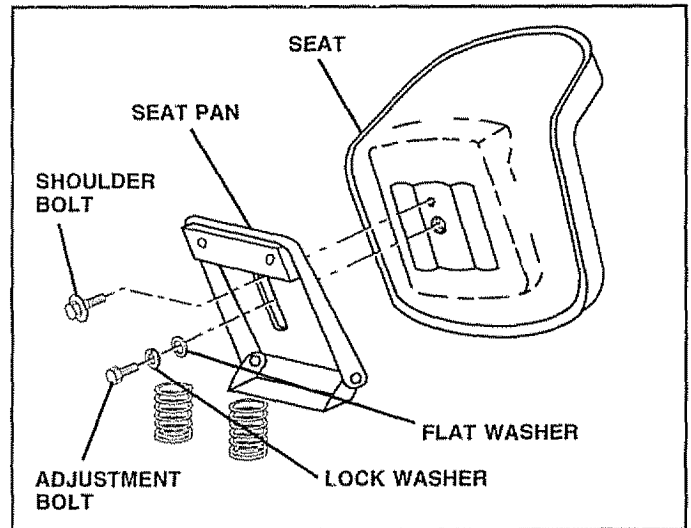

FIG. 3

### CHECK TIRE PRESSURE

The tires on your unit were overinflated at the factory for shipping purposes. Correct tire pressure is important for best cutting performance.

- Reduce tire pressure to PSI shown in "PRODUCT SPECIFICATIONS" on page 3 of this manual.

### CHECK DECK LEVELNESS

For best cutting results, mower housing should be properly leveled. See "TO LEVEL MOWER HOUSING" in the Service and Adjustments section of this manual.

### CHECK FOR PROPER POSITION OF ALL BELTS

See the figures that are shown for replacing motion and mower blade drive belts in the Service and Adjustments section of this manual. Verify that the belts are routed correctly.

### CHECK BRAKE SYSTEM

After you learn how to operate your tractor, check to see that the brake is properly adjusted. See "TO ADJUST BRAKE" in the Service and Adjustments section of this manual.



# ASSEMBLY

## INSTALL BATTERY (See Figs. 4 & 5)



**CAUTION:** Do not short battery terminals. Before installing battery, remove metal bracelets, wristwatch bands, rings, etc.

Positive terminal must be connected first to prevent sparking from accidental grounding.

- Lift seat to raised position.
- Open battery box door.
- Lower battery into battery box with battery terminals toward front of unit.
- Be sure battery drain tube is attached to battery box.
- First connect RED battery cable to positive (+) battery terminal with hex bolt, flat washer, lock washer and hex nut as shown. Tighten securely.
- Connect BLACK grounding cable to negative (-) battery terminal with remaining hex bolt, flat washer, lock washer and hex nut. Tighten securely.
- Close battery box door.

Open battery box door for:

- Inspection for secure connections (to tighten hardware).
- Inspection for corrosion.
- Testing battery.
- Jumping (if required).
- Periodic charging.

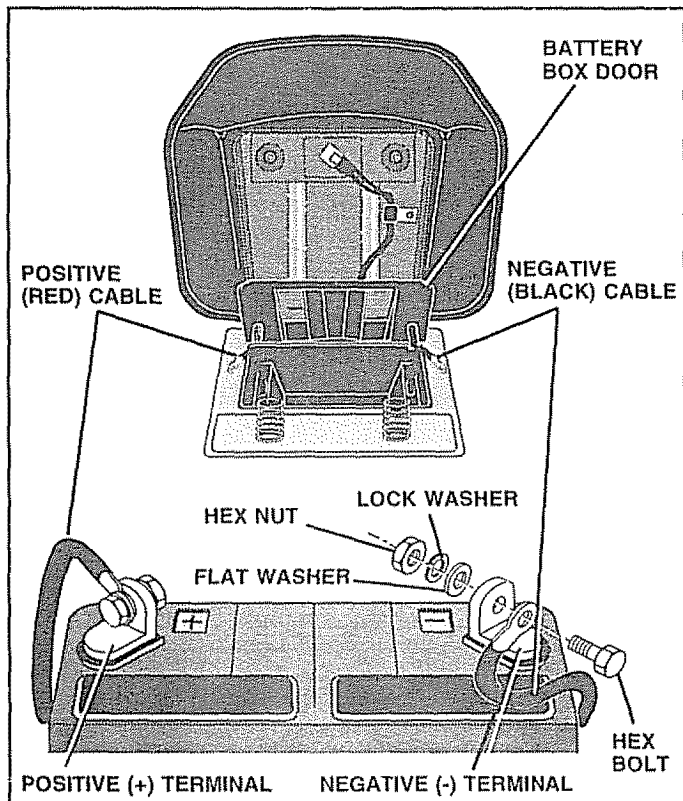

FIG. 4

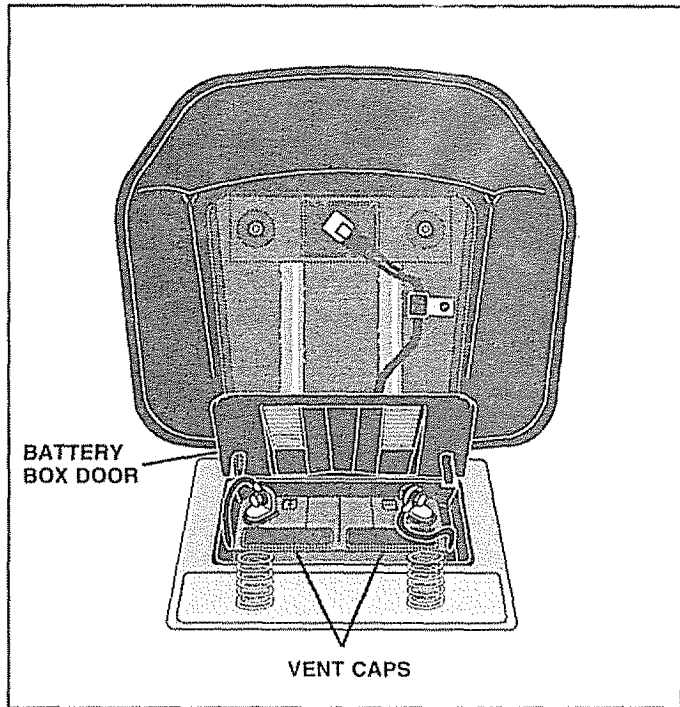

FIG. 5

## ASSEMBLE GAUGE WHEELS TO MOWER DECK (See Fig.6)

Assemble gauge wheels with tractor on a flat level surface.

- Adjust mower to desired cutting height (See "TO ADJUST MOWER CUTTING HEIGHT" in the Operation section of this manual).
- With mower in desired height of cut position, gauge wheels should be assembled so they are slightly off the ground. Install gauge wheel in appropriate hole with shoulder bolt and locknut and tighten securely.
- Repeat for opposite side installing gauge wheel in same adjustment hole.

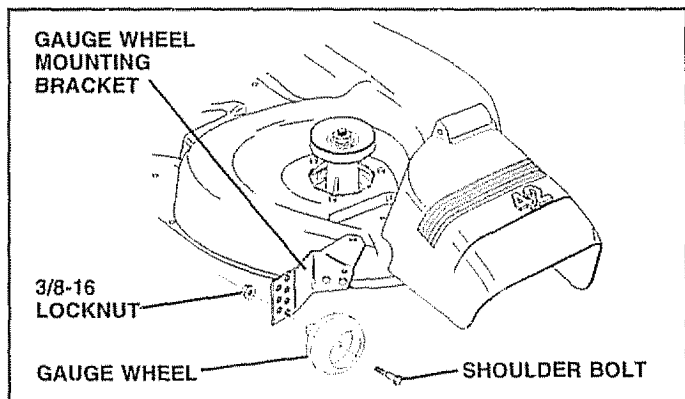

FIG. 6

# ASSEMBLY

## INSTALL MULCHER PLATE (See Figs. 7A & 7B)

- Install two latch hooks, to mulcher plate using screw, washer, lock washer, and weld nut as shown. **NOTE:** Pre-assemble weld nut to latch hook by inserting weld nut from the top with hook pointing down.
- Tighten hardware securely.
- Raise and hold deflector shield in upright position.
- Place front of mulcher plate over front of mower deck opening and slide into place, as shown.
- Hook front latch into hole on front of mower deck.
- Hook rear latch into hole on back of mower deck.



**CAUTION:** Do not remove discharge guard from mower. Raise and hold guard when attaching mulcher plate and allow it to rest on plate while in operation.

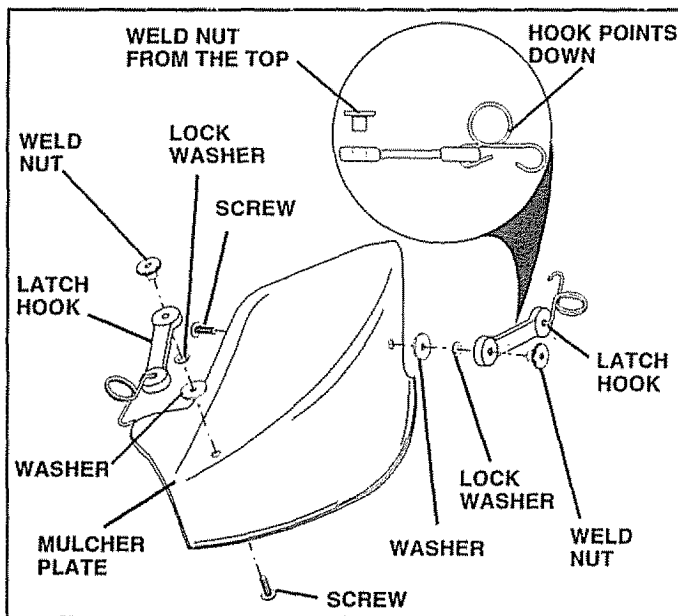

FIG. 7A

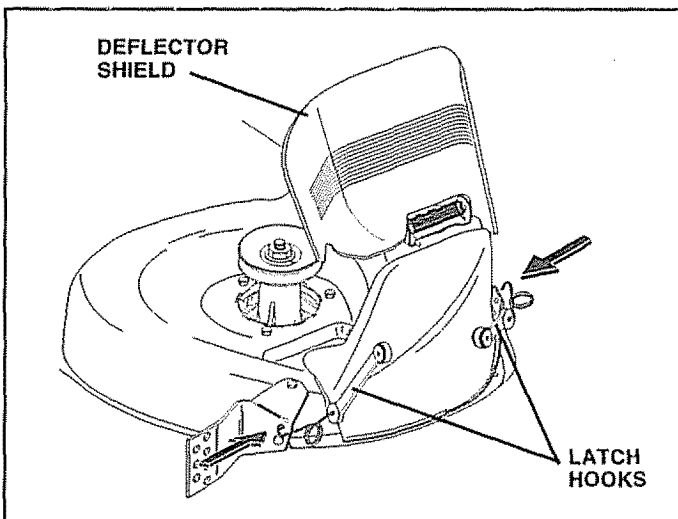

FIG. 7B

## TO CONVERT TO BAGGING OR DISCHARGING

Simply remove mulcher plate and store in a safe place. Your mower is now ready for discharging or installation of optional grass catcher accessory.

## ✓ CHECKLIST

*BEFORE YOU OPERATE AND ENJOY YOUR NEW TRACTOR, WE WISH TO ASSURE THAT YOU RECEIVE THE BEST PERFORMANCE AND SATISFACTION FROM THIS QUALITY PRODUCT.*

*PLEASE REVIEW THE FOLLOWING CHECKLIST:*

- ✓ All assembly instructions have been completed.
- ✓ No remaining loose parts in carton.
- ✓ Battery is properly prepared and charged. (Minimum 1 hour at 6 amps).
- ✓ Seat is adjusted comfortably and tightened securely.
- ✓ All tires are properly inflated. (For shipping purposes, the tires were overinflated at the factory).
- ✓ Be sure mower deck is properly leveled side-to-side/front-to-rear for best cutting results. (Tires must be properly inflated for leveling).
- ✓ Check mower and drive belts. Be sure they are routed properly around pulleys and inside all belt keepers.
- ✓ Check wiring. See that all connections are still secure and wires are properly clamped.

*WHILE LEARNING HOW TO USE YOUR TRACTOR, PAY EXTRA ATTENTION TO THE FOLLOWING IMPORTANT ITEMS:*

- ✓ Engine oil is at proper level.
- ✓ Fuel tank is filled with fresh, clean, regular unleaded gasoline.
- ✓ Become familiar with all controls - their location and function. Operate them before you start the engine.
- ✓ Be sure brake system is in safe operating condition.

# OPERATION

## KNOW YOUR TRACTOR

### READ THIS OWNER'S MANUAL AND SAFETY RULES BEFORE OPERATING YOUR TRACTOR

Compare the illustrations with your tractor to familiarize yourself with the locations of various controls and adjustments. Save this manual for future reference.

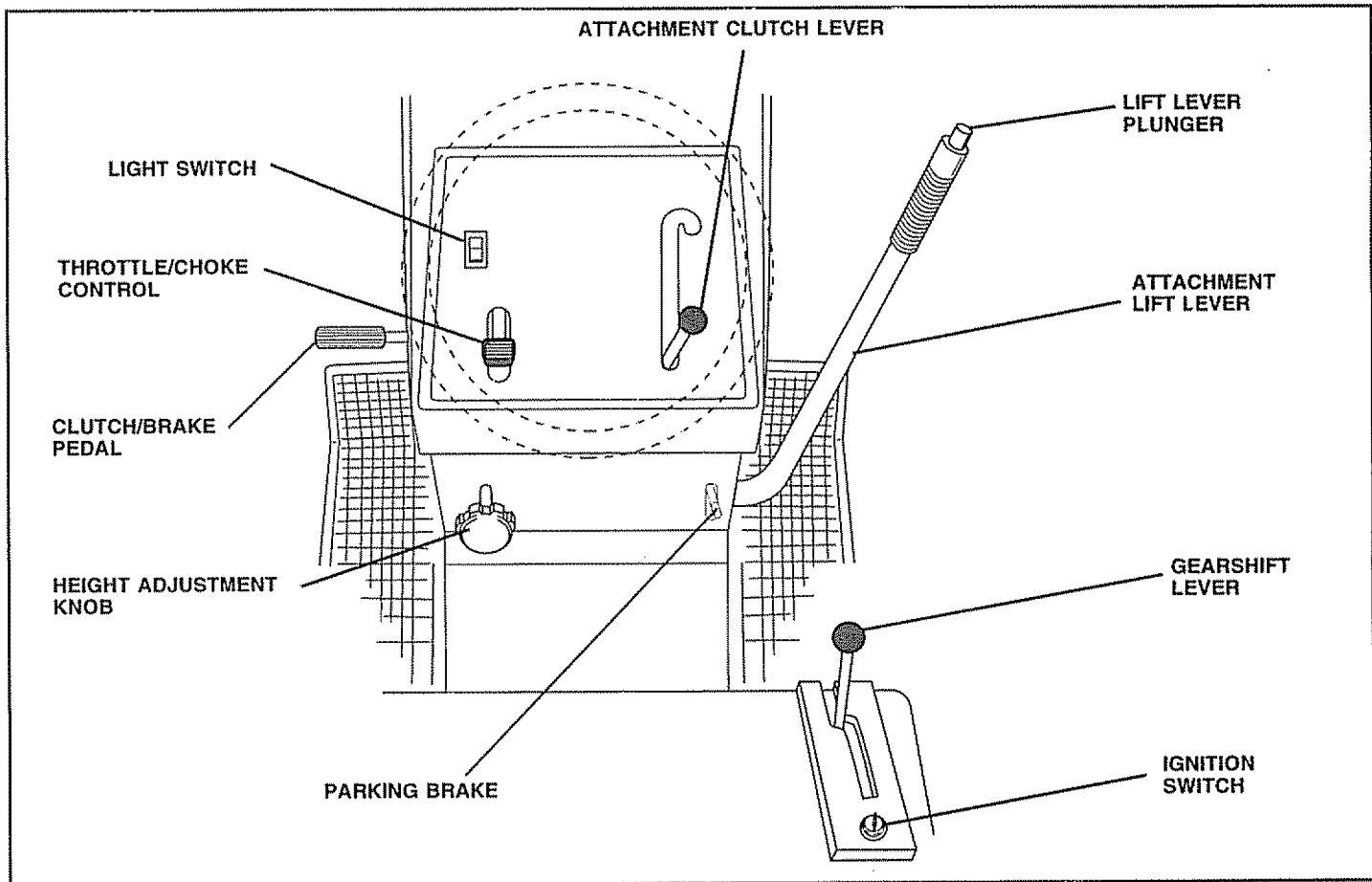

FIG. 8

Sears tractors conform to the safety standards of the American National Standards Institute.

**ATTACHMENT CLUTCH LEVER:** Used to engage the mower blades, or other attachments mounted to your tractor.

**LIGHT SWITCH:** Turns the headlights on and off.

**THROTTLE/CHOKE CONTROL:** Used for starting and controlling engine speed.

**CLUTCH/BRAKE PEDAL:** Used for declutching and braking the tractor and starting the engine.

**PARKING BRAKE:** Locks clutch/brake pedal into the brake position.

**GEARSHIFT LEVER:** Selects the speed and direction of tractor.

**ATTACHMENT LIFT LEVER:** Used to raise and lower the mower deck or other attachments mounted to your tractor.

**LIFT LEVER PLUNGER:** Used to release attachment lift lever when changing its position.

**IGNITION SWITCH:** Used for starting and stopping the engine.

**HEIGHT ADJUSTMENT KNOB:** Used to adjust the mower cutting height.

# OPERATION

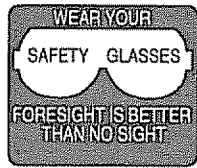

The operation of any tractor can result in foreign objects thrown into the eyes, which can result in severe eye damage. Always wear safety glasses or eye shields while operating your tractor or performing any adjustments or repairs. We recommend wide vision safety mask for over the spectacles or standard safety glasses, available at Sears Retail or Catalog stores.

## HOW TO USE YOUR TRACTOR

### TO SET PARKING BRAKE (See Fig. 9)

Your unit is equipped with an operator presence sensing switch. When engine is running, any attempt by the operator to leave the seat without first setting the parking brake will shut off the engine.

- Depress clutch/brake pedal into full "BRAKE" position and hold.
- Place parking brake lever in "ENGAGED" position and release pressure from clutch/brake pedal. Pedal should remain in "BRAKE" position. Make sure parking brake will hold vehicle secure.

### STOPPING (See Fig. 9)

#### MOWER BLADES -

- Move attachment clutch lever to "DISENGAGED" position.

#### GROUND DRIVE -

- Depress clutch/brake pedal into full "BRAKE" position.
- Move gearshift lever to "NEUTRAL" position.

#### ENGINE -

- Move throttle control to "SLOW" position.

**NOTE:** Failure to move throttle control to "SLOW" position and allowing engine to idle before stopping may cause engine to "backfire".

- Turn ignition key to "OFF" position and remove key. Always remove key when leaving vehicle to prevent unauthorized use.
- Never use choke to stop engine.

**NOTE:** Under certain conditions when unit is standing idle with the engine running, hot engine exhaust gasses may cause "browning" of grass. To eliminate this possibility, always stop engine when stopping unit on grass areas.



**CAUTION:** Always stop unit completely, as described above, before leaving the operator's position; to empty grass catcher, etc.

### TO USE THROTTLE CONTROL (See Fig. 9)

Always operate engine at full throttle.

- Operating engine at less than full throttle reduces the battery charging rate.
- Full throttle offers the best bagging and mower performance.

### TO MOVE FORWARD AND BACKWARD (See Fig. 9)

The direction and speed of movement is controlled by the gearshift lever.

- Start tractor with clutch/brake pedal depressed and gearshift lever in "NEUTRAL" position.
- Move gearshift lever to desired position.
- Slowly release clutch/brake pedal to start movement.

**IMPORTANT:** BRING TRACTOR TO A COMPLETE STOP BEFORE SHIFTING OR CHANGING GEARS. FAILURE TO DO SO WILL SHORTEN THE USEFUL LIFE OF YOUR TRANSAXLE.

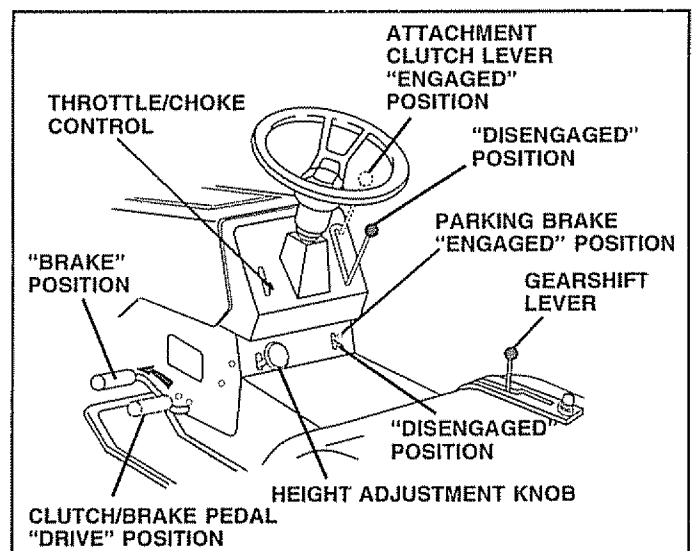

FIG. 9

### TO ADJUST MOWER CUTTING HEIGHT (See Fig. 9)

The cutting height is controlled by turning the height adjustment knob in desired direction.

- Turn knob clockwise (↻) to raise cutting height.
- Turn knob counterclockwise (↺) to lower cutting height.

The cutting height range is approximately 1-1/2" to 4". The heights are measured from the ground to the blade tip with the engine not running. These heights are approximate and may vary depending upon soil conditions, height of grass and types of grass being mowed.

- The average lawn should be cut to approximately 2-1/2 inches during the cool season and to over 3 inches during hot months. For healthier and better looking lawns, mow often and after moderate growth.
- For best cutting performance, grass over 6 inches in height should be mowed twice. Make the first cut relatively high; the second to desired height.

# OPERATION

## TO OPERATE MOWER (See Fig. 10)

Your unit is equipped with an operator presence sensing switch. Any attempt by the operator to leave the seat with the engine running and the mower clutch engaged will shut off the engine.

- Select desired height of cut.
- Lower mower with attachment lift control.
- Start mower blades by engaging attachment clutch control.
- TO STOP MOWER BLADES - disengage attachment clutch control.



**CAUTION:** Do not operate the mower without either the entire grass catcher, on mowers so equipped, or the discharge guard in place.

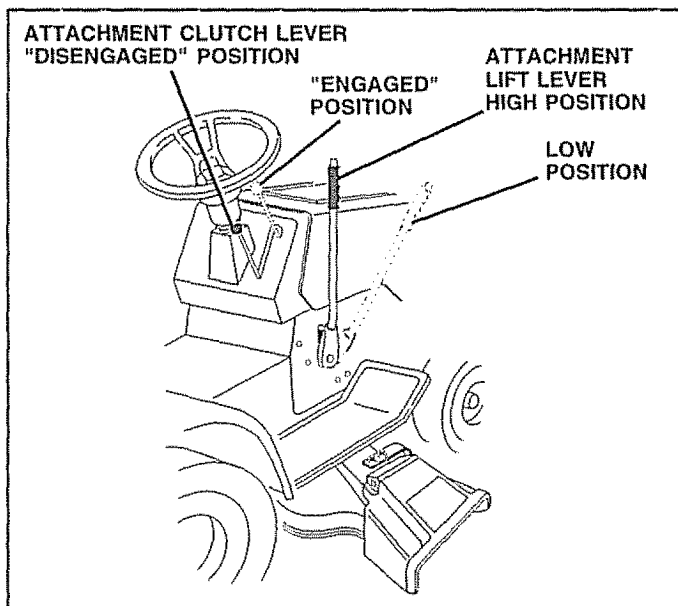

FIG. 10

## TO OPERATE ON HILLS



**CAUTION:** Do not drive up or down hills with slopes greater than 15° and do not drive across any slope.

- Choose the slowest speed before starting up or down hills.
- Avoid stopping or changing speed on hills.
- If slowing is necessary, move throttle control lever to slower position.
- If stopping is absolutely necessary, push clutch/brake pedal quickly to brake position and engage parking brake.
- Move gearshift lever to 1st gear and be sure you have allowed room for tractor to roll slightly as you restart movement.

- To restart movement, slowly release parking brake and clutch/brake pedal.
- Make all turns slowly.

## TO TRANSPORT

- Raise attachment lift control to highest position.
- When pushing or towing your unit, be sure gearshift lever is in "NEUTRAL" position.
- Do not push or tow unit at more than five (5) MPH.

**NOTE:** To protect hood from damage when transporting your tractor on a truck or a trailer, be sure hood is closed and secured to tractor. Use an appropriate means of tying hood to tractor (rope, cord, etc.).

## BEFORE STARTING THE ENGINE

### CHECK ENGINE OIL LEVEL (See Fig. 16)

- The engine in your unit has been shipped, from the factory, already filled with summer weight oil.
- Check engine oil with unit on level ground.
- Unthread and remove oil fill cap/dipstick; wipe oil off. Reinsert the dipstick into the tube and rest oil fill cap on the tube. Do not thread the cap onto the tube. Remove and read oil level. If necessary, add oil until "FULL" mark on dipstick is reached. Do not overfill.
- For cold weather operation you should change oil for easier starting (See "OIL VISCOSITY CHART" in the Customer Responsibilities section of this manual).
- To change engine oil, see the Customer Responsibilities section in this manual.

### ADD GASOLINE

- Fill fuel tank. Use fresh, clean, regular unleaded gasoline. (Use of leaded gasoline will increase carbon and lead oxide deposits and reduce valve life).

**IMPORTANT:** WHEN OPERATING IN TEMPERATURES BELOW 32°F (0°C), USE FRESH, CLEAN WINTER GRADE GASOLINE TO HELP INSURE GOOD COLD WEATHER STARTING.

**WARNING:** Experience indicates that alcohol blended fuels (called gasohol or using ethanol or methanol) can attract moisture which leads to separation and formation of acids during storage. Acidic gas can damage the fuel system of an engine while in storage. To avoid engine problems, the fuel system should be emptied before storage of 30 days or longer. Drain the gas tank, start the engine and let it run until the fuel lines and carburetor are empty. Use fresh fuel next season. See Storage Instructions for additional information. Never use engine or carburetor cleaner products in the fuel tank or permanent damage may occur.



**CAUTION:** Fill to bottom of gas tank filler neck. Do not overfill. Wipe off any spilled oil or fuel. Do not store, spill or use gasoline near an open flame.

# OPERATION

## TO START ENGINE (See Fig. 9)

When starting engine for the first time or if engine has run out of fuel, it will take extra cranking time to move fuel from the tank to the engine.

- Depress the clutch/brake pedal and set the parking brake.
- Place gearshift lever in "NEUTRAL" position.
- Move attachment clutch to "DISENGAGED" position.
- Move throttle control lever to "CHOKE" position for cold engine start. For warm engine start, move throttle control to "FAST" position.
- Turn ignition key clockwise to "START" position and release key as soon as engine starts. Do not run starter continuously for more than fifteen seconds per minute. If engine does not start after several attempts, move throttle control to "FAST" position, wait a few minutes and try again.
- When engine starts, move throttle control to desired position.
- Allow engine to warm up for a few minutes before engaging drive or attachment clutch.

**NOTE:** If at a high altitude (above 3000 feet) or in cold temperatures (below 32° F), the carburetor fuel mixture may need to be adjusted for best engine performance. See "TO ADJUST CARBURETOR" in the Service and Adjustments section of this manual.

## MOWING TIPS

- Tire chains cannot be used when the mower housing is attached to unit.
- Mower should be properly leveled for best mowing performance. See "TO LEVEL MOWER HOUSING" in the Service and Adjustments section of this manual.
- The left hand side of mower should be used for trimming.
- Drive so that clippings are discharged onto the area that has been cut. Have the cut area to the right of the machine. This will result in a more even distribution of clippings and more uniform cutting.
- When mowing large areas, start by turning to the right so that clippings will discharge away from shrubs, fences, driveways, etc. After one or two rounds, mow in the opposite direction making left hand turns until finished (See Fig. 11).

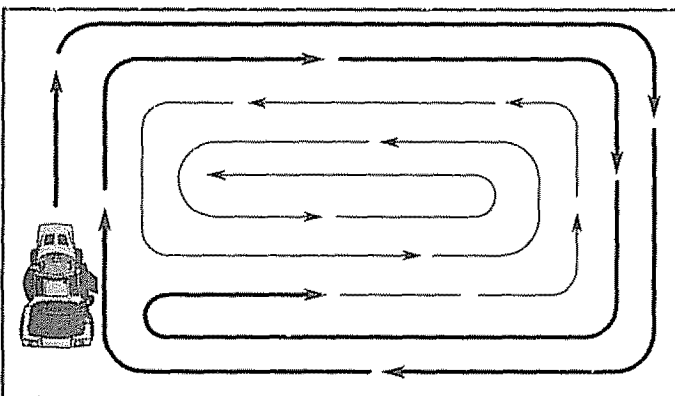

FIG. 11

- If grass is extremely tall, it should be mowed twice to reduce load and possible fire hazard from dried clippings. Make first cut relatively high; the second to the desired height.
- Do not mow grass when it is wet. Wet grass will plug mower and leave undesirable clumps. Allow grass to dry before mowing.
- Always operate engine at full throttle when mowing to assure better mowing performance and proper discharge of material. Regulate ground speed by selecting a low enough gear to give the mower cutting performance as well as the quality of cut desired.
- When operating attachments, select a ground speed that will suit the terrain and give best performance of the attachment being used.

## MULCHING MOWING TIPS

**IMPORTANT:** FOR BEST PERFORMANCE, KEEP MOWER HOUSING FREE OF BUILT-UP GRASS AND TRASH. CLEAN AFTER EACH USE.

- The special mulching blade will recut the grass clippings many times and reduce them in size so that as they fall onto the lawn they will disperse into the grass and not be noticed. Also, the mulched grass will biodegrade quickly to provide nutrients for the lawn. Always mulch with your highest engine (blade) speed as this will provide the best recutting action of the blades.
- Avoid cutting your lawn when it is wet. Wet grass tends to form clumps and interferes with the mulching action. The best time to mow your lawn is the early afternoon. At this time the grass has dried and the newly cut area will not be exposed to the direct sun.
- For best results, adjust the mower cutting height so that the mower cuts off only the top one-third of the grass blades (See Fig. 12). For extremely heavy mulching, reduce your width of cut and mow slowly.

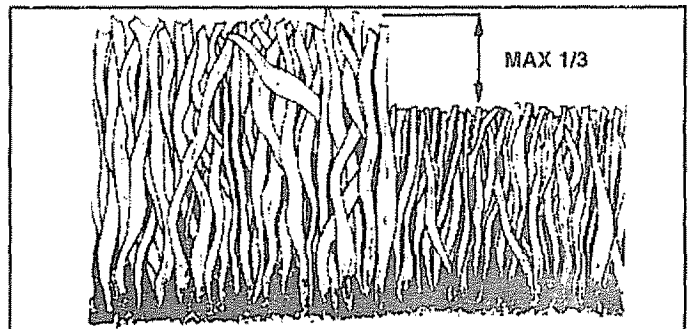

FIG. 12

- Certain types of grass and grass conditions may require that an area be mulched a second time to completely hide the clippings. When doing a second cut, mow across or perpendicular to the first cut path.
- Change your cutting pattern from week to week. Mow north to south one week then change to east to west the next week. This will help prevent matting and graining of the lawn.

# CUSTOMER RESPONSIBILITIES

MAINTENANCE SCHEDULE FILL IN DATES AS YOU COMPLETE REGULAR SERVICE		BEFORE EACH USE					SERVICE DATES						
		BEFORE EACH USE	FIRST 2 HOURS	EVERY 8 HOURS	EVERY 25 HOURS	EVERY 50 HOURS	EVERY 100 HOURS	EVERY SEASON	BEFORE STORAGE				
TRACTOR	Check Brake Operation	✓		✓									
	Check Tire Pressure	✓		✓									
	Check for Loose Fasteners	✓							✓				
	Sharpen/Replace Mower Blades				✓ <sub>4</sub>								
	Lubrication Chart				✓				✓				
	Check Battery Level/Recharge				✓								
	Clean Battery and Terminals				✓					✓			
	Check Transaxle Cooling				✓								
	Adjust Blade Belt(s) Tension							✓ <sub>5</sub>					
	Adjust Motion Drive Belt(s) Tension							✓ <sub>5</sub>					
ENGINE	Check Engine Oil Level	✓		✓									
	Change Engine Oil		✓		✓ <sub>1,2,3</sub>				✓				
	Clean Air Filter				✓ <sub>2</sub>								
	Clean Air Screen				✓ <sub>2</sub>								
	Inspect Muffler/Spark Arrester					✓							
	Replace Oil Filter (If equipped)							✓ <sub>1,2</sub>					
	Clean Engine Cooling Fins							✓ <sub>2</sub>					
	Replace Spark Plug							✓	✓				
	Replace Air Filter Paper Cartridge							✓ <sub>2</sub>					
	Replace Fuel Filter								✓				

1 - Change more often when operating under a heavy load or in high ambient temperatures  
2 - Service more often when operating in dirty or dusty conditions

3 - If equipped with oil filter, change oil every 50 hours  
4 - Replace blades more often when mowing in sandy soil  
5 - If equipped with adjustable system

## GENERAL RECOMMENDATIONS

The warranty on this tractor does not cover items that have been subjected to operator abuse or negligence. To receive full value from the warranty, operator must maintain tractor as instructed in this manual.

Some adjustments will need to be made periodically to properly maintain your tractor.

All adjustments in the Service and Adjustments section of this manual should be checked at least once each season.

- Once a year you should replace the spark plug, clean or replace air filter, and check blades and belts for wear. A new spark plug and clean air filter assure proper air-fuel mixture and help your engine run better and last longer.

## BEFORE EACH USE

- Check engine oil level.
- Check brake operation.
- Check tire pressure.
- Check for loose fasteners.

## LUBRICATION CHART

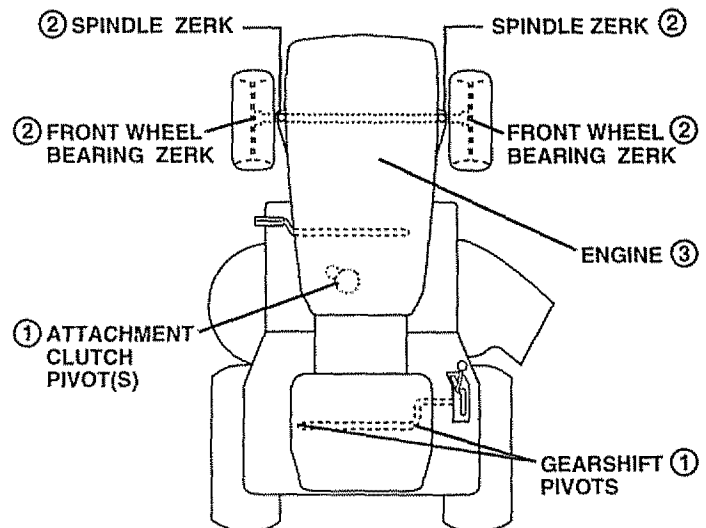

- SAE 30 OR 10W30 MOTOR OIL API - SG
- GENERAL PURPOSE GREASE
- REFER TO CUSTOMER RESPONSIBILITIES "ENGINE" SECTION

**IMPORTANT:** DO NOT OIL OR GREASE THE PIVOT POINTS WHICH HAVE SPECIAL NYLON BEARINGS. VISCOUS LUBRICANTS WILL ATTRACT DUST AND DIRT THAT WILL SHORTEN THE LIFE OF THE SELF-LUBRICATING BEARINGS. IF YOU FEEL THEY MUST BE LUBRICATED, USE ONLY A DRY, POWDERED GRAPHITE TYPE LUBRICANT SPARINGLY.

# CUSTOMER RESPONSIBILITIES

## TRACTOR

Always observe safety rules when performing any maintenance.

## BRAKE OPERATION

If unit requires more than six (6) feet stopping distance at high speed in highest gear, than brake must be adjusted. (See "TO ADJUST BRAKE" in Service and Adjustments section of this manual).

## TIRES

- Maintain proper air pressure in all tires (See "PRODUCT SPECIFICATIONS" on page 3 of this manual).
- Keep tires free of gasoline, oil, or insect control chemicals which can harm rubber.
- Avoid stumps, stones, deep ruts, sharp objects and other hazards that may cause tire damage.

## BLADE CARE

For best results mower blades must be kept sharp. Replace bent or damaged blades.

## BLADE REMOVAL (See Fig. 13)

- Raise mower to highest position to allow access to blades.
- Remove hex bolt, lock washer and flat washer securing blade.
- Install new or resharpened blade with trailing edge up towards deck as shown.
- Reassemble hex bolt, lock washer and flat washer in exact order as shown.
- Tighten bolt securely (30-35 Ft. Lbs. torque).

**IMPORTANT:** BLADE BOLT IS GRADE 8 HEAT TREATED.

**NOTE:** We do not recommend sharpening blade but if you do, be sure blade is balanced.

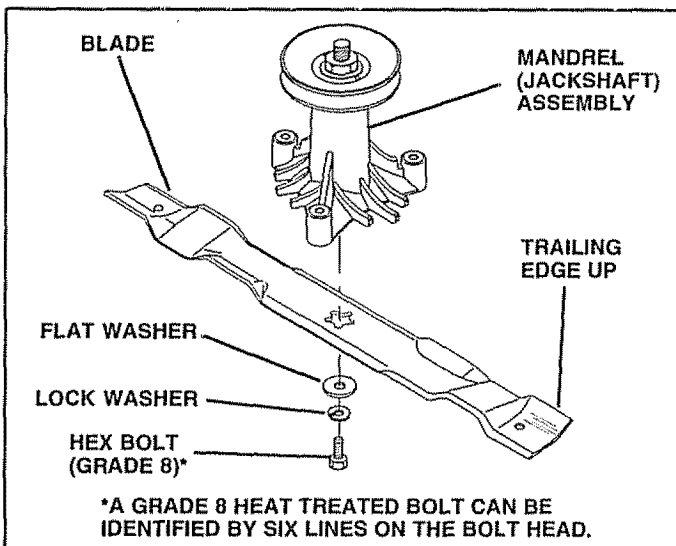

FIG. 13

## TO SHARPEN BLADE (See Fig. 14)

Care should be taken to keep the blade balanced. An unbalanced blade will cause excessive vibration and eventual damage to mower and engine.

- The blade can be sharpened with a file or on a grinding wheel. Do not attempt to sharpen while on the mower.
- To check blade balance, you will need a 5/8" diameter steel bolt, pin, or a cone balancer. (When using a cone balancer, follow the instructions supplied with balancer).
- Slide blade on to an unthreaded portion of the steel bolt or pin and hold the bolt or pin parallel with the ground. If blade is balanced, it should remain in a horizontal position. If either end of the blade moves downward, sharpen the heavy end until the blade is balanced.

**NOTE:** Do not use a nail for balancing blade. The lobes of the center hole may appear to be centered, but are not.

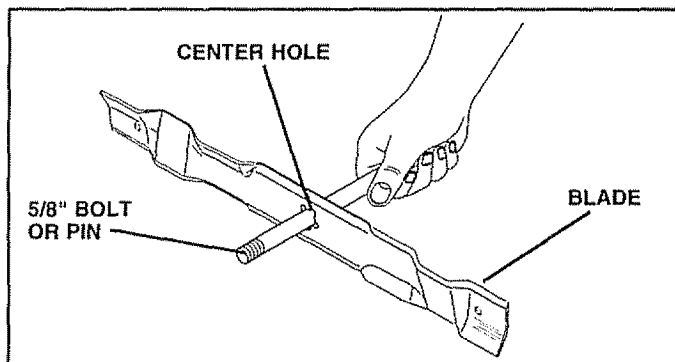

FIG. 14



# CUSTOMER RESPONSIBILITIES

## BATTERY (See Fig. 15)

Your unit has a battery charging system which is sufficient for normal use. However, periodic charging of the battery with an automotive charger will extend its life.

- Acid solution level in each battery cell should be even with bottoms of vent wells. Add only distilled or iron free water if necessary. Do not overfill.

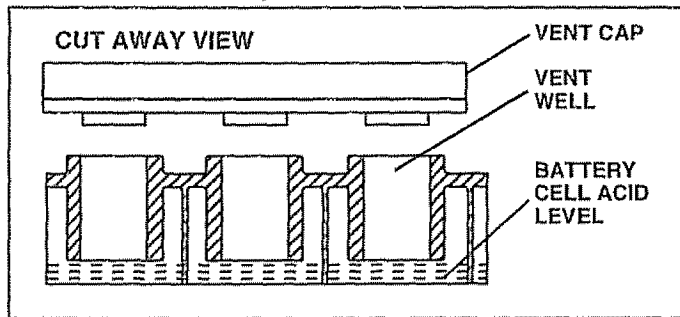

FIG. 15

- Keep battery and terminals clean.
- Keep battery bolts tight.
- Keep vent caps tight and small vent holes in caps open.
- Recharge at 6 amperes for 1 hour.

### TO CLEAN BATTERY AND TERMINALS -

Corrosion and dirt on the battery and terminals can cause the battery to "leak" power.

- Open battery box door.
- Disconnect BLACK battery cable first then RED battery cable and remove battery from tractor.
- Wash battery with solution of four tablespoons of baking soda to one gallon of water. Be careful not to get the soda solution into the cells.
- Rinse the battery with plain water and dry.
- Clean terminals and battery cable ends with wire brush until bright.
- Coat terminals with grease or petroleum jelly.
- Reinstall battery (See "INSTALL BATTERY" in the Assembly section of this manual).

## V-BELTS

Check V-belts for deterioration and wear after 100 hours and replace if necessary. The belts are not adjustable. Replace belts if they begin to slip from wear.

## TRANSAXLE COOLING

Keep transaxle free from build-up of dirt and chaff which can restrict cooling.

## ENGINE

### LUBRICATION

Only use high quality detergent oil rated with API service classification SG. Select the oil's SAE viscosity grade according to your expected operating temperature.

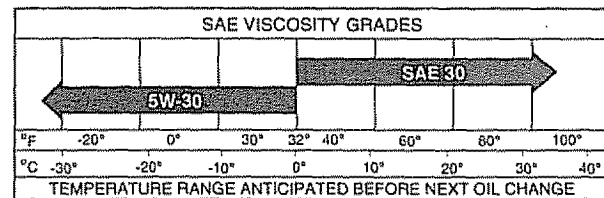

**NOTE:** Although multi-viscosity oils (5W30, 10W30 etc.) improve starting in cold weather, these multi-viscosity oils will result in increased oil consumption when used above 32°F. Check your engine oil level more frequently to avoid possible engine damage from running low on oil.

Change the oil after the first two hours of operation and every 50 hours thereafter or at least once a year if the tractor is not used for 50 hours in one year.

Check the crankcase oil level before starting the engine and after each eight (8) hours of continuous use. Tighten oil fill cap/dipstick securely each time you check the oil level.

# CUSTOMER RESPONSIBILITIES

## TO CHANGE ENGINE OIL (See Fig. 16)

Determine temperature range expected before oil change. All oil must meet API service classification SG.

- Be sure vehicle is on level surface.
- Oil will drain more freely when warm.
- Catch oil in a suitable container.
- Remove oil fill dipstick. Be careful not to allow dirt to enter the engine when changing oil.
- Remove drain plug.
- After oil has drained completely, replace oil drain plug and tighten securely.
- Refill engine with oil through oil fill dipstick tube. Pour slowly. Do not overfill. For approximate capacity see Product Specifications on page 3 of this manual.
- Use gauge on oil fill dipstick for checking level. Insert dipstick into the tube and rest the oil fill cap on the tube. Do not thread the cap onto the tube when taking reading. Keep oil at "FULL" line on dipstick. Tighten cap onto the tube securely when finished.

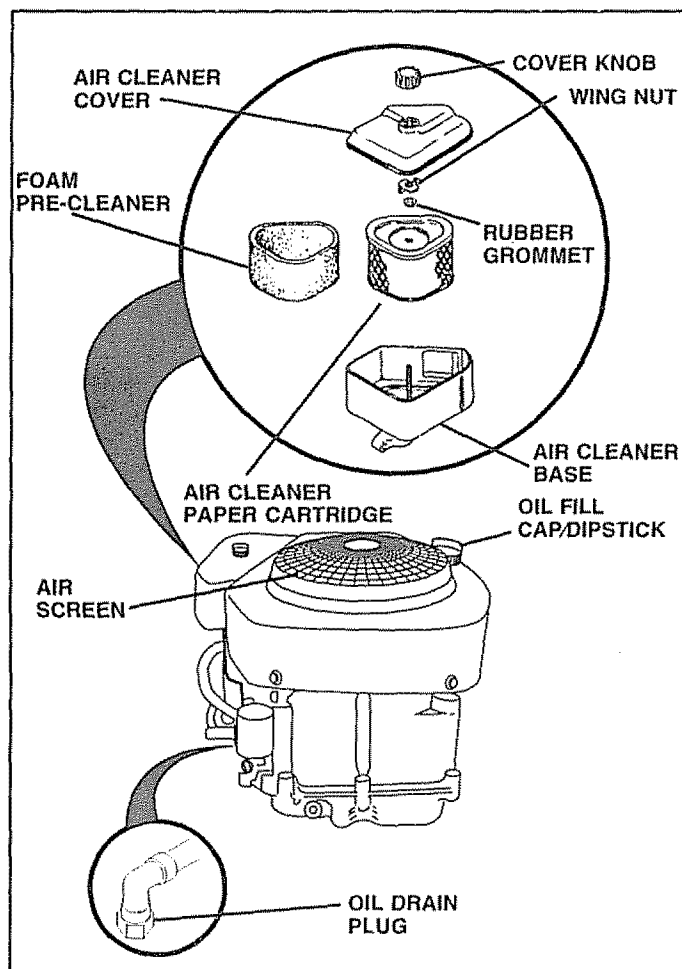

FIG. 16

## AIR FILTER (See Fig.16)

Your engine will not run properly using a dirty air filter. Clean the foam pre-cleaner element after every 25 hours of operation or every season. Service paper cartridge every 100 hours or every season, whichever occurs first.

Service air cleaner more often under dusty conditions.

- Remove knob and cover.
- Remove wing nut and air cleaner from base.

### TO SERVICE PRE-CLEANER

- Slide foam pre-cleaner off cartridge.
- Wash it in liquid detergent and water.
- Squeeze it dry in a clean cloth.
- Saturate it in engine oil. Wrap it in clean, absorbent cloth and squeeze to remove excess oil.

### TO SERVICE CARTRIDGE

- Gently tap the flat side of the paper cartridge to dislodge dirt. Do not wash the paper cartridge or use pressurized air, as this will damage the cartridge. Replace a dirty, bent, or damaged cartridge.
- Reinstall the pre-cleaner (cleaned and oiled) over the paper cartridge.
- Reassemble air cleaner, wing nut, cover and tighten knob securely.

## CLEAN AIR SCREEN (See Fig. 16)

Air screen must be kept free of dirt and chaff to prevent engine damage from overheating. Clean with a wire brush or compressed air to remove dirt and stubborn dried gum fibers.

## CLEAN AIR INTAKE/COOLING AREAS

To insure proper cooling, make sure the grass screen, cooling fins, and other external surfaces of the engine are kept clean at all times.

Every 100 hours of operation (more often under extremely dusty, dirty conditions), remove the blower housing and other cooling shrouds. Clean the cooling fins and external surfaces as necessary. Make sure the cooling shrouds are reinstalled.

**NOTE:** Operating the engine with a blocked grass screen, dirty or plugged cooling fins, and/or cooling shrouds removed, will cause engine damage due to overheating.

# CUSTOMER RESPONSIBILITIES

## ENGINE OIL FILTER (See Fig. 17)

Replace the engine oil filter every season or every other oil change if the tractor is used more than 100 hours in one year.

- Drain oil from engine crankcase (See "TO CHANGE ENGINE OIL" through step remove drain plug).
- Remove oil filter and wipe off filter adapter.
- Apply a thin coating of new engine oil to the rubber gasket on replacement oil filter.
- Install replacement oil filter on filter adapter. Turn oil filter clockwise until rubber gasket contacts the filter adapter, then tighten filter an additional 1/2 turn.
- Fill crankcase with new oil ( See "TO CHANGE ENGINE OIL" in this section of this manual). For approximate capacity see "PRODUCT SPECIFICATIONS" on page 3 of this manual.
- Start the engine and check for oil leaks. Correct any leaks before placing engine into full operation.

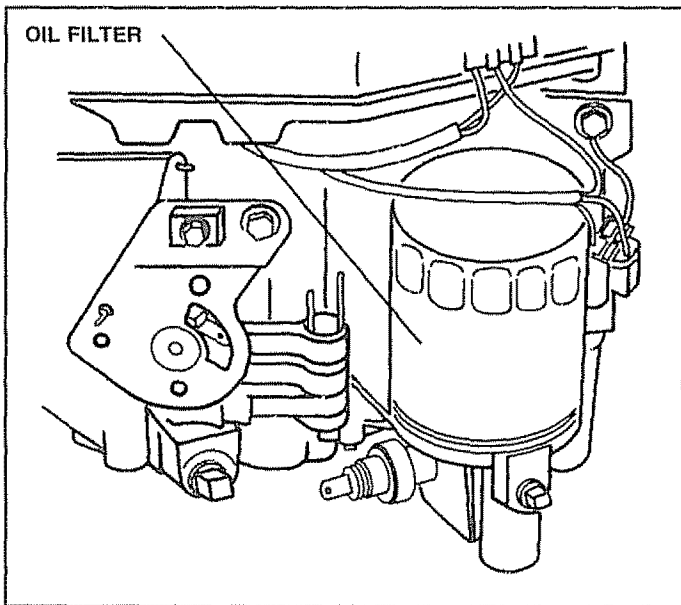

FIG. 17

## MUFFLER

Inspect and replace corroded muffler and spark arrester (if equipped) as it could create a fire hazard and/or damage.

## SPARK PLUGS

Replace spark plugs at the beginning of each mowing season or after every 100 hours of use, whichever comes first. Spark plug type and gap setting is shown in "PRODUCT SPECIFICATIONS" on page 3 of this manual.

## IN-LINE FUEL FILTER (See Fig. 18)

Fuel filter should be replaced once each season. If fuel filter becomes clogged, obstructing fuel flow to carburetor, replacement is required.

- With engine cool, remove filter and plug fuel line sections.
- Place new fuel filter in position in fuel line.
- Be sure there are no fuel line leaks and clamps are properly positioned.
- Immediately wipe up any spilled gasoline.

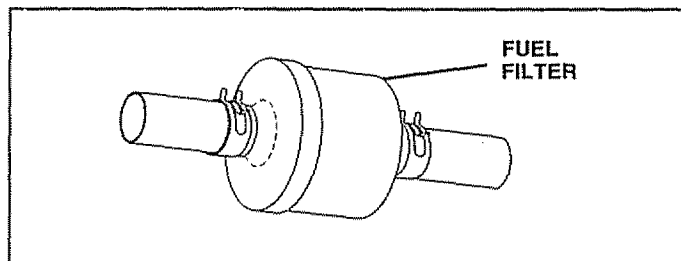

FIG. 18

## CLEANING

- Clean engine, battery, seat, finish, etc. of all foreign matter.
- Keep finished surfaces and wheels free of all gasoline, oil, etc.
- Protect painted surfaces with automotive type wax.

We do not recommend using a garden hose to clean your unit unless the electrical system, muffler, air filter and carburetor are covered to keep water out. Water in engine can result in a shortened engine life.

# SERVICE AND ADJUSTMENTS



## CAUTION: BEFORE PERFORMING ANY SERVICE OR ADJUSTMENTS:

- Depress clutch/brake pedal fully and set parking brake.
- Place gearshift lever in "NEUTRAL" position.
- Place attachment clutch in "DISENGAGED" position.
- Turn ignition key "OFF" and remove key.
- Make sure the blades and all moving parts have completely stopped.
- Disconnect spark plug wire from spark plug and place wire where it cannot come in contact with plug.

## TRACTOR

### TO REMOVE MOWER (See Fig. 19)

Mower will be easier to remove from the right side of tractor.

- Place attachment clutch in "DISENGAGED" position.
- Move attachment lift lever forward to lower mower to its lowest position.
- Roll belt off engine pulley.
- Disconnect clutch rod from clutch lever by removing retainer spring.
- Disconnect anti-sway bar from chassis bracket by removing retainer spring.
- Disconnect suspension arms from rear deck brackets by removing retainer springs.
- Disconnect front links from deck by removing retainer springs.
- Raise lift lever to raise suspension arms. Slide mower out from under tractor.

**IMPORTANT:** IF AN ATTACHMENT OTHER THAN THE MOWER IS TO BE MOUNTED TO THE TRACTOR, THE R.H. AND L.H. SUSPENSION ARMS MUST BE REMOVED FROM TRACTOR.

### TO INSTALL MOWER (See Fig. 19)

- Raise attachment lift lever to its highest position.
- Slide mower under tractor with discharge guard to right side of tractor.
- Lower lift lever to its lowest position.
- Install mower in reverse order of removal instructions.

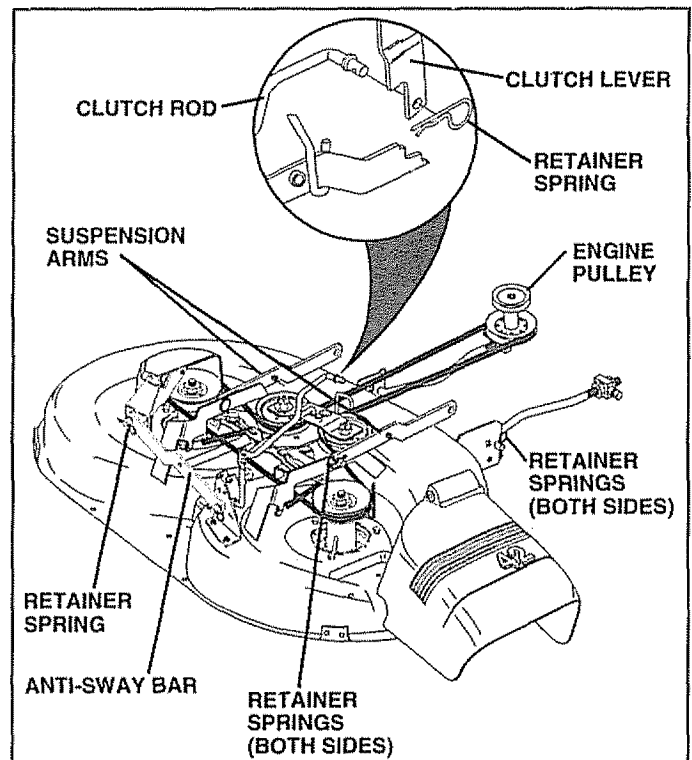

FIG. 19

# SERVICE AND ADJUSTMENTS

## TO LEVEL MOWER HOUSING

Adjust the mower while tractor is parked on level ground or driveway. Make sure tires are properly inflated (See "PRODUCT SPECIFICATIONS" on page 3). If tires are over or under inflated, you will not properly adjust your mower.

### SIDE-TO-SIDE ADJUSTMENT (See Figs. 20 and 21)

You will need two (2) standard 2 x 4 short pieces of wood to make the following adjustment. Similar blocks measuring 1-1/2" thick may also be used.

- Raise mower with attachment lift control to allow two (2) 1-1/2" thick blocks to be placed under rear edge of mower.
- Place one block directly behind the left mandrel. Place the remaining block under the stamped ridge on the right rear edge of mower deck.
- Lower mower deck to its lowest height of cut position (See "TO ADJUST MOWER CUTTING HEIGHT" in Operation section of this manual).
- On both sides of tractor, loosen, but do not remove, the fasteners securing the adjustable pivot brackets to frame. Both brackets must be loose enough to move freely.
- Pull down firmly on suspension arm to remove any slack in pivot bracket and hold while tightening rear fastener first to secure. Tighten remaining fastener.
- Repeat procedure on other side of tractor.
- Raise mower with attachment lift control and remove blocks from under mower.

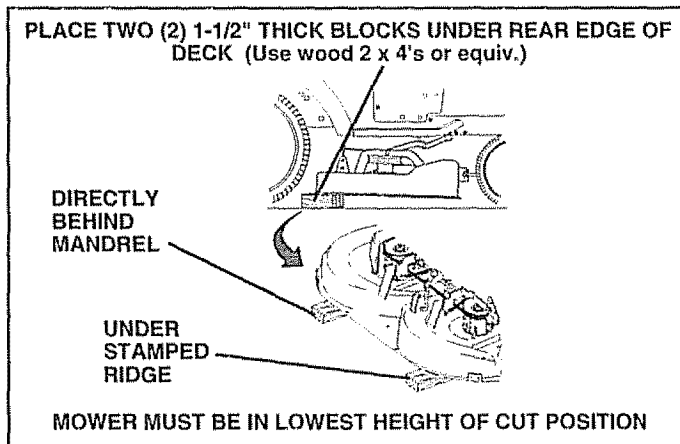
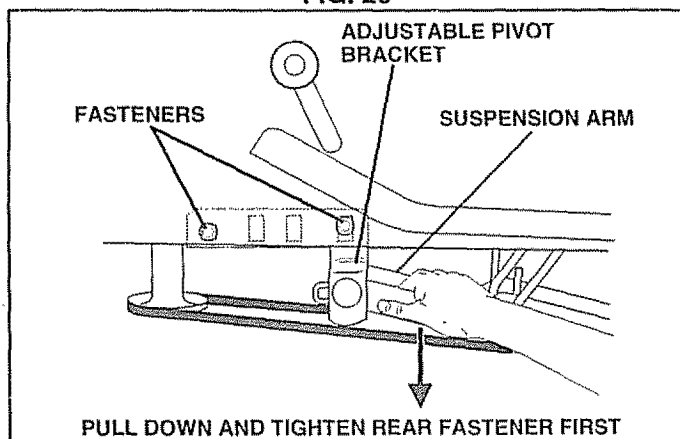

FIG. 20



### FRONT-TO-BACK ADJUSTMENT (See Figs. 22 and 23) -

**IMPORTANT:** DECK MUST BE LEVEL SIDE-TO-SIDE. IF THE FOLLOWING FRONT-TO-BACK ADJUSTMENT IS NECESSARY, BE SURE TO ADJUST BOTH FRONT LINKS EQUALLY SO MOWER WILL STAY LEVEL SIDE-TO-SIDE.

To obtain the best cutting results, the mower housing should be adjusted so that the front is approximately 1/4" to 3/4" lower than the rear when the mower is in its highest position.

Check adjustment on right side of tractor. Measure distance "D" directly in front and behind the mandrel at bottom edge of mower housing as shown.

- Before making any necessary adjustments, check that both front links are equal in length. Both links should be approximately 10-3/8".
- If links are not equal in length, adjust one link to same length as other link.
- To lower front of mower loosen nut "E" on both front links an equal number of turns.
- When distance "D" is 1/4" to 3/4" lower at front than rear, tighten nuts "F" against trunnion on both front links.
- To raise front of mower, loosen nut "F" from trunnion on both front links. Tighten nut "E" on both front links an equal number of turns.
- When distance "D" is 1/4" to 3/4" lower at front than rear, tighten nut "F" against trunnion on both front links.
- Recheck side-to-side adjustment.

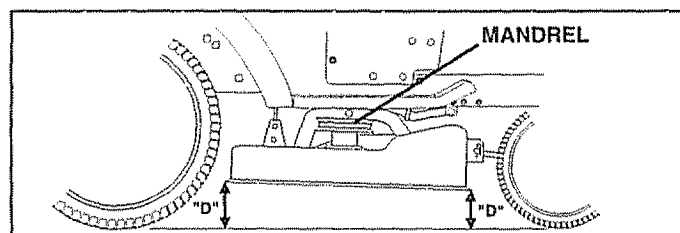

FIG. 22

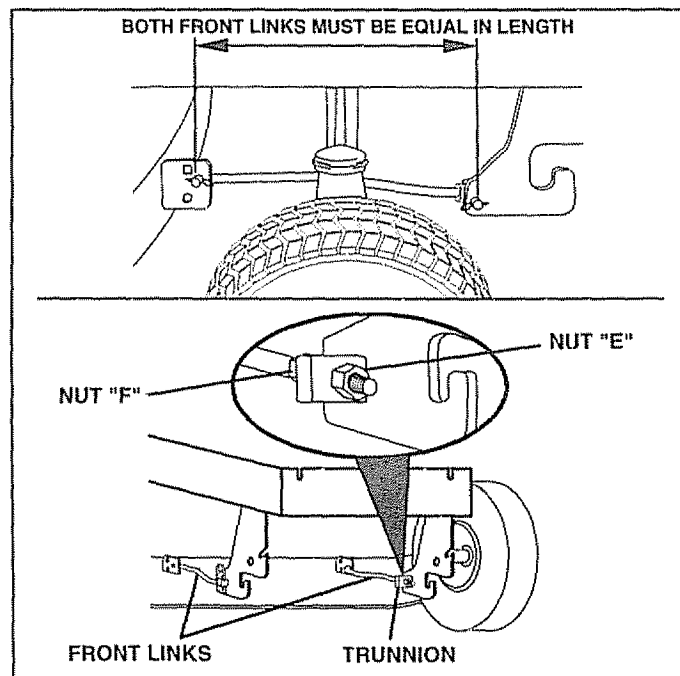

FIG. 23

# SERVICE AND ADJUSTMENTS

## TO REPLACE MOWER BLADE DRIVE BELT (See Fig. 24)

The mower blade drive belt may be replaced without tools. Park the tractor on level surface. Engage parking brake. For assistance, there is a belt installation guide decal on the mower housing.

### BELT REMOVAL -

- Place attachment clutch in "DISENGAGED" position.
- Move attachment lift lever forward to lower mower to its lowest position.
- Roll belt off engine pulley.
- Work belt off both mandrel pulleys and idler pulleys.
- Pull belt away from mower.

### BELT INSTALLATION -

- Install new belt in reverse order of removal.
- Make sure belt is in all pulley grooves and inside all belt guides.

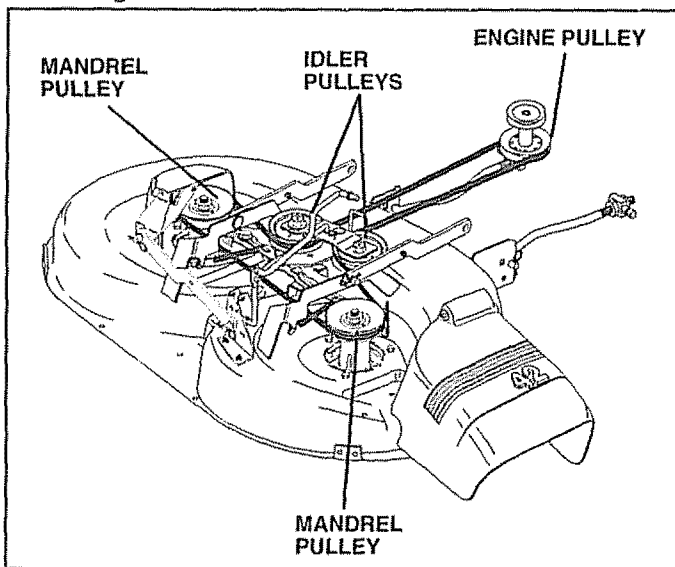

FIG. 24

## TO ADJUST BRAKE (See Fig. 25)

Your unit is equipped with an adjustable brake system which is mounted on the right side of the transaxle.

If unit requires more than six (6) feet stopping distance at high speed in highest gear, then brake must be adjusted.

- Depress clutch/brake pedal and engage parking brake.
- Measure distance between brake operating arm and nut "A" on brake rod.
- If distance is other than 1-1/2", disengage parking brake, loosen jam nut and turn nut "A" until distance becomes 1-1/2". Retighten jam nut against nut "A".
- Engage parking brake and recheck distance.
- Road test unit for proper stopping distance as stated above. Readjust if necessary. If stopping distance is still greater than six (6) feet in highest gear, further maintenance is necessary. Contact your nearest authorized service center.

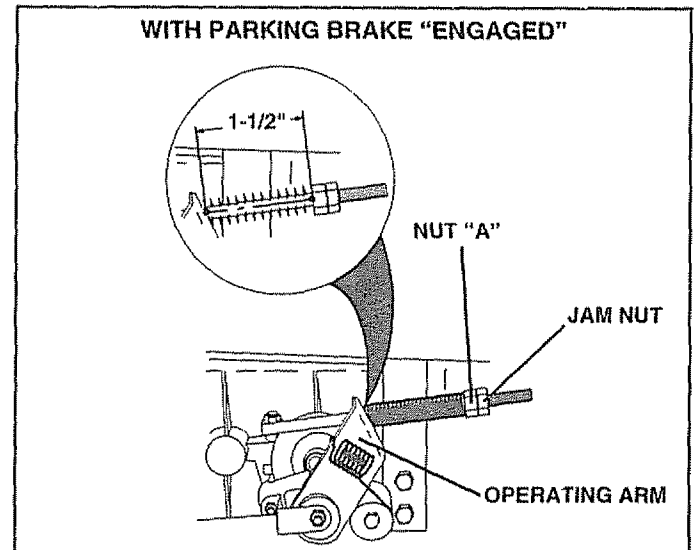

FIG. 25

## TO REPLACE MOTION DRIVE BELT (See Fig. 26)

Park the tractor on level surface. Engage parking brake. For assistance, there is a belt installation guide decal on bottom side of left footrest.

- Remove mower (See "TO REMOVE MOWER" in this section of this manual.)
- Remove upper belt keeper.
- Remove belt from stationary idler and clutching idler.
- Pull belt slack toward rear of tractor. Remove belt upwards from transaxle pulley by deflecting belt keepers.
- Pull belt toward front of tractor and remove downwards from around engine pulley.
- Install new belt by reversing above procedure.

**IMPORTANT:** MAKE SURE UPPER BELT KEEPER IS POSITIONED PROPERLY BETWEEN LOCATOR TABS.

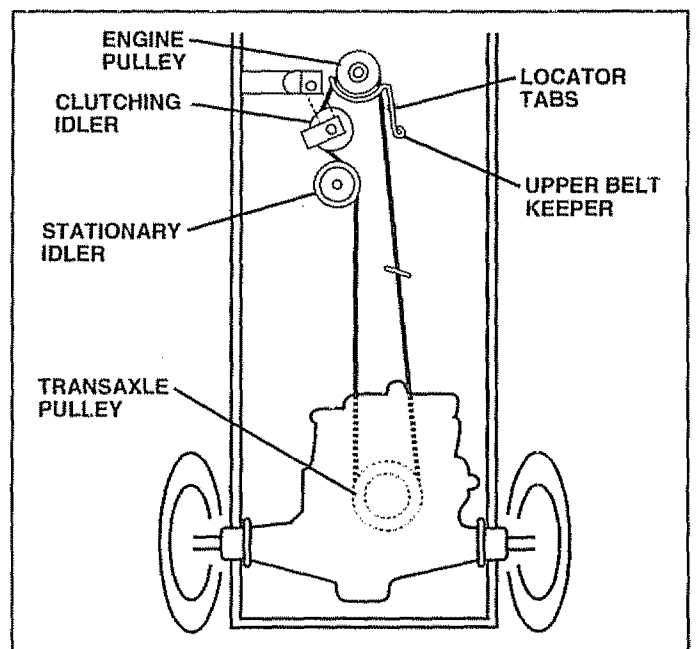

FIG. 26

# SERVICE AND ADJUSTMENTS

## TO ADJUST STEERING WHEEL ALIGNMENT

If steering wheel crossbars are not horizontal (left to right) when wheels are positioned straight forward, remove steering wheel and reassemble per instructions in the Assembly section of this manual.

## FRONT WHEEL TOE-IN/CAMBER

The front wheel toe-in and camber are not adjustable on your tractor. If damage has occurred to affect the front wheel toe-in or camber, contact your nearest authorized service center.

## TO REMOVE WHEEL FOR REPAIRS (See Fig. 27)

- Block up axle securely.
- Remove axle cover, retaining ring and washers to allow wheel removal (rear wheel contains a square key - Do not lose).
- Repair tire and reassemble.
- On rear wheels only: align grooves in rear wheel hub and axle. Insert square key.
- Replace washers and snap retaining ring securely in axle groove.
- Replace axle cover.

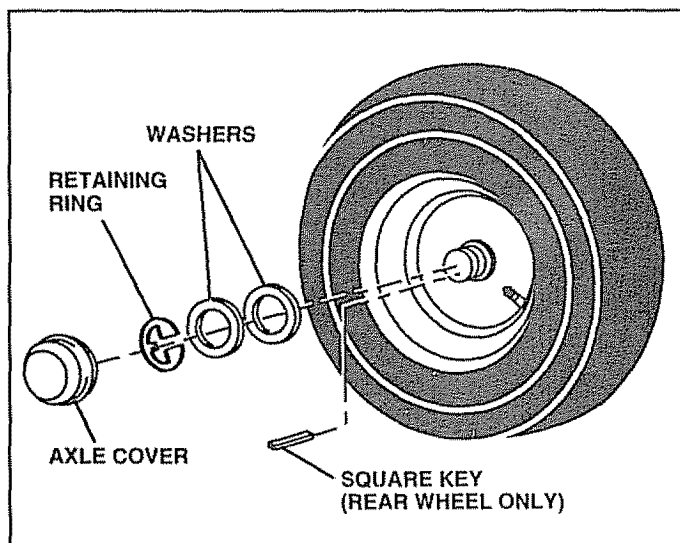

FIG. 27

## TO START ENGINE WITH A WEAK BATTERY (See Fig. 28)



**CAUTION:** Lead-acid batteries generate explosive gases. Keep sparks, flame and smoking materials away from batteries. Always wear eye protection when around batteries.

If your battery is too weak to start the engine, it should be recharged. If "jumper cables" are used for emergency starting, follow this procedure:

**IMPORTANT:** YOUR UNIT IS EQUIPPED WITH A 12 VOLT NEGATIVE GROUND SYSTEM. THE OTHER VEHICLE MUST ALSO BE A 12 VOLT NEGATIVE GROUND SYSTEM. DO NOT USE YOUR TRACTOR BATTERY TO START OTHER VEHICLES.

### TO ATTACH JUMPER CABLES -

- Connect each end of the RED cable to the POSITIVE (+) terminal of each battery, taking care not to short against chassis.
- Connect one end of the BLACK cable to the NEGATIVE (-) terminal of fully charged battery.
- Connect the other end of the BLACK cable to a good CHASSIS GROUND, away from fuel tank and battery.

### TO REMOVE CABLES, REVERSE ORDER -

- BLACK cable first from chassis and then from the fully charged battery.
- RED cable last from both batteries.

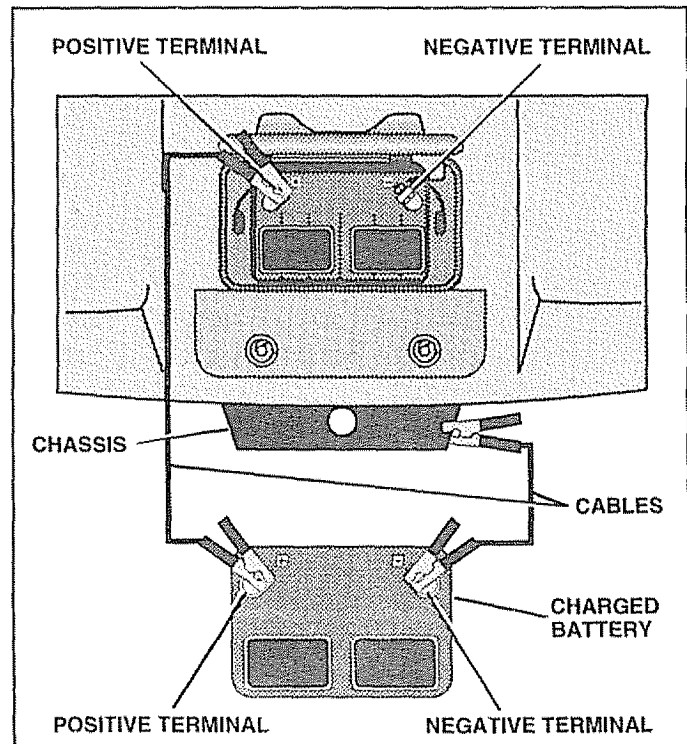

FIG. 28

---

# SERVICE AND ADJUSTMENTS

---

## TO REPLACE HEADLIGHT BULB

- Raise hood.
- Pull bulb holder out of the hole in the backside of the grill.
- Replace bulb in holder and push bulb holder securely back into the hole in the backside of the grill.
- Close hood.

## INTERLOCKS AND RELAYS

Loose or damaged wiring may cause your tractor to run poorly, stop running or prevent it from starting.

- Check wiring. See electrical wiring diagram in Repair Parts section of this manual.

## TO REPLACE FUSE

Replace with 30 amp automotive-type plug-in fuse. The fuse holder is located in the engine compartment, directly in front of the dash.

## TO REMOVE HOOD AND GRILL (See Fig. 29)

- Raise hood.
- Unsnap headlight wire connector.
- Stand in front of tractor. Grasp hood at sides, tilt forward and lift off of tractor.
- To reinstall, slide hood pivot brackets into slots in frame.
- Reconnect headlight wire connector and close hood.

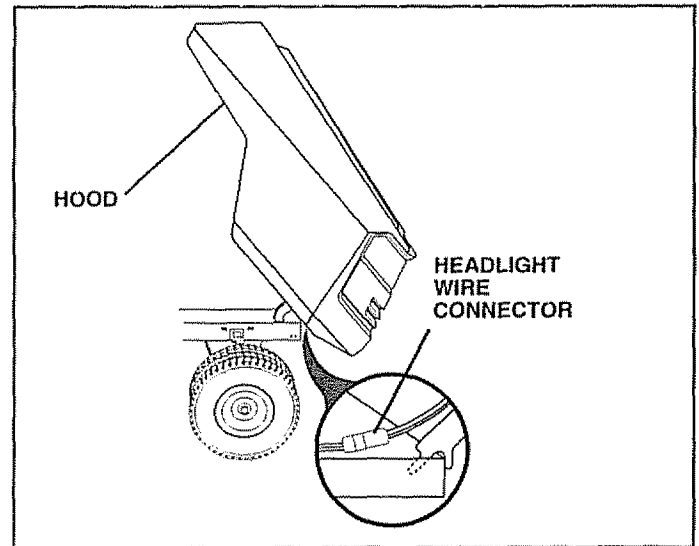

FIG. 29



# SERVICE AND ADJUSTMENTS

## ENGINE

### TO ADJUST THROTTLE CONTROL CABLE (See Fig. 30)

The throttle control has been preset at the factory and adjustment should not be necessary. Check adjustment as described below before loosening cable. If adjustment is necessary, proceed as follows:

- With engine not running, move throttle control lever from "SLOW" to "CHOKE" position. Slowly move lever from "CHOKE" to "FAST" position.
- Check to see if hole in throttle lever and hole in speed control bracket are aligned.
- If holes are not aligned, loosen cable clamp screw and align the holes by inserting a pencil or a 1/4" drill bit through both holes.
- Pull throttle cable up to remove slack and tighten cable clamp screw. Remove alignment pencil or drill bit.

### TO ADJUST CARBURETOR (See Fig. 31)

The carburetor has been preset at the factory and adjustment should not be necessary. However, minor adjustment may be required to compensate for differences in fuel, temperature, altitude or load. If the carburetor does need adjustment, proceed as follows:

In general, turning the adjusting needles **in** (clockwise) decreases the supply of fuel to the engine giving a leaner fuel/air mixture. Turning the adjusting needles **out** (counterclockwise) increases the supply of fuel to the engine giving a richer fuel/air mixture.

**IMPORTANT:** DAMAGE TO THE NEEDLES AND THE SEATS IN CARBURETOR MAY RESULT IF NEEDLE IS TURNED IN TOO TIGHT.

#### PRELIMINARY SETTING -

- Be sure you have a clean air filter and the throttle control cable is adjusted properly (see above).
- With engine off turn idle fuel adjusting needle **in** (clockwise) closing it finger tight and then turn **out** (counterclockwise) 1 turn.

#### FINAL SETTING -

- Start engine and allow to warm for five minutes. Make final adjustments with engine running and shift/motion control lever in "NEUTRAL" position.
- Idle speed setting - With throttle control lever in "SLOW" position, engine should idle at 1750 RPM. If engine idles too slow or fast, turn idle speed adjusting screw in or out until correct idle is attained.
- Idle fuel needle setting - With throttle control lever in "SLOW" position, turn idle fuel adjusting needle **in** (clockwise) until engine begins to die and then turn **out** (counterclockwise) approximately 1/8 to 1/4 turn to obtain best low speed performance.
- Recheck idle speed. Readjust if necessary.

#### ACCELERATION TEST -

- Move throttle control lever from "SLOW" to "FAST" position. If engine hesitates or dies, turn idle fuel adjusting needle **out** (counterclockwise) 1/8 turn. Repeat test and continue to adjust, if necessary, until engine accelerates smoothly.

High speed stop is factory adjusted. Do not adjust - damage may result.

**IMPORTANT:** NEVER TAMPER WITH THE ENGINE GOVERNOR, WHICH IS FACTORY SET FOR PROPER ENGINE SPEED. OVERSPEEDING THE ENGINE ABOVE THE FACTORY HIGH SPEED SETTING CAN BE DANGEROUS. IF YOU THINK THE ENGINE-GOVERNED HIGH SPEED NEEDS ADJUSTING, CONTACT YOUR NEAREST AUTHORIZED SERVICE CENTER, WHICH HAS PROPER EQUIPMENT AND EXPERIENCE TO MAKE ANY NECESSARY ADJUSTMENTS.

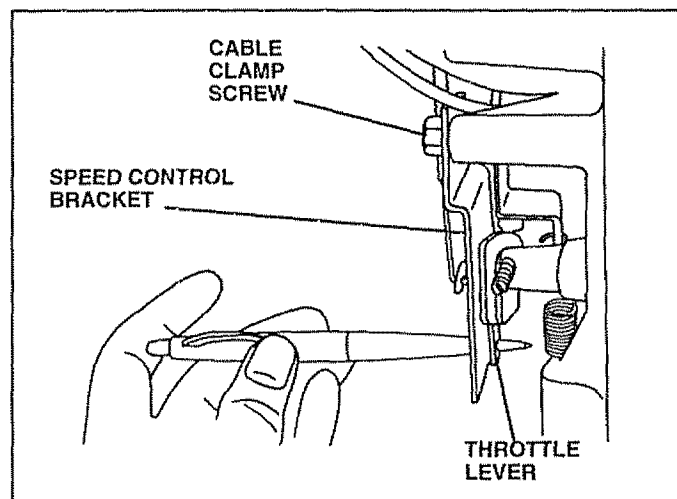

FIG. 30

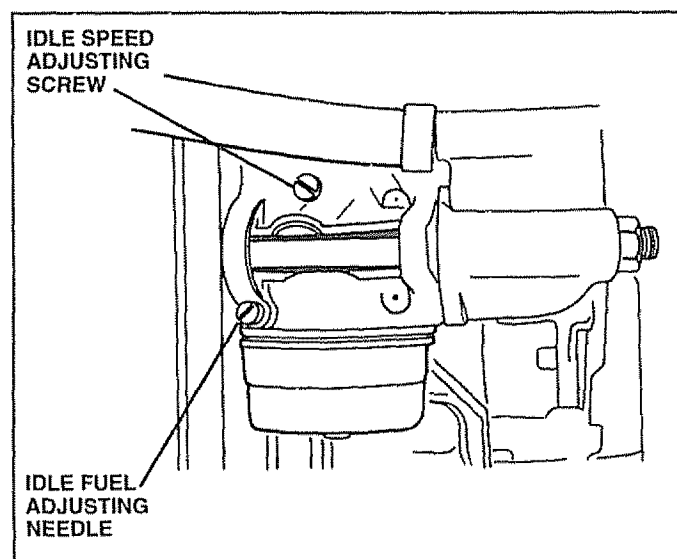

FIG. 31

# STORAGE

Immediately prepare your tractor for storage at the end of the season or if the tractor will not be used for 30 days or more.



**CAUTION:** Never store the tractor with gasoline in the tank inside a building where fumes may reach an open flame or spark. Allow the engine to cool before storing in any enclosure.

## TRACTOR

Remove mower from tractor for winter storage. When mower is to be stored for a period of time, clean it thoroughly, remove all dirt, grease, leaves, etc. Store in a clean, dry area.

- Clean entire tractor (See "CLEANING" in the Customer Responsibilities section of this manual).
- Inspect and replace belts, if necessary (See belt replacement instructions in the Service and Adjustments section of this manual).
- Lubricate as shown in the Customer Responsibilities section of this manual.
- Be sure that all nuts, bolts and screws are securely fastened. Inspect moving parts for damage, breakage and wear. Replace if necessary.
- Touch up all rusted or chipped paint surfaces; sand lightly before painting.

## BATTERY

- Fully charge the battery for storage.
- After a period of time in storage, battery may require recharging.
- To help prevent corrosion and power leakage during long periods of storage, battery cables should be disconnected and battery cleaned thoroughly (see "TO CLEAN BATTERY AND TERMINALS" in the Customer Responsibilities section of this manual).
- After cleaning, leave cables disconnected and place cables where they cannot come in contact with battery terminals.
- Be sure battery drain tube is securely attached.
- If battery is removed from tractor for storage, do not store battery directly on concrete or damp surfaces.

## ENGINE

### FUEL SYSTEM

**IMPORTANT:** IT IS IMPORTANT TO PREVENT GUM DEPOSITS FROM FORMING IN ESSENTIAL FUEL SYSTEM PARTS SUCH AS CARBURETOR, FUEL FILTER, FUEL HOSE, OR TANK DURING STORAGE. ALSO, EXPERIENCE INDICATES THAT ALCOHOL BLENDED FUELS (CALLED GASOHOL OR USING ETHANOL OR METHANOL) CAN ATTRACT MOISTURE WHICH LEADS TO SEPARATION AND FORMATION OF ACIDS DURING STORAGE. ACIDIC GAS CAN DAMAGE THE FUEL SYSTEM OF AN ENGINE WHILE IN STORAGE.

- Drain the fuel tank.
- Start the engine and let it run until the fuel lines and carburetor are empty.
- Never use engine or carburetor cleaner products in the fuel tank or permanent damage may occur.
- Use fresh fuel next season.

**NOTE:** Fuel stabilizer is an acceptable alternative in minimizing the formation of fuel gum deposits during storage. Add stabilizer to gasoline in fuel tank or storage container. Always follow the mix ratio found on stabilizer container. Run engine at least 10 minutes after adding stabilizer to allow the stabilizer to reach the carburetor. Do not drain the gas tank and carburetor if using fuel stabilizer.

### ENGINE OIL

Drain oil (with engine warm) and replace with clean engine oil. (See "ENGINE" in the Customer Responsibilities section of this manual).

### CYLINDERS

- Remove spark plug(s).
- Pour one ounce of oil through spark plug hole(s) into cylinder(s).
- Turn ignition key to "START" position for a few seconds to distribute oil.
- Replace with new spark plug(s).

## OTHER

- Do not store gasoline from one season to another.
- Replace your gasoline can if your can starts to rust. Rust and/or dirt in your gasoline will cause problems.
- If possible, store your tractor indoors and cover it to give protection from dust and dirt.
- Cover your tractor with a suitable protective cover that does not retain moisture. Do not use plastic. Plastic cannot breathe which allows condensation to form and will cause your tractor to rust.

**IMPORTANT:** NEVER COVER TRACTOR WHILE ENGINE AND EXHAUST AREAS ARE STILL WARM.

# TROUBLESHOOTING POINTS

PROBLEM	CAUSE	CORRECTION
<b>Will not start</b>	<ol style="list-style-type: none"> <li>1. Out of fuel.</li> <li>2. Engine not "CHOKED" properly.</li> <li>3. Engine flooded.</li> <li>4. Bad spark plug.</li> <li>5. Dirty air filter.</li> <li>6. Dirty fuel filter.</li> <li>7. Water in fuel.</li>   <li>8. Loose or damaged wiring.</li> <li>9. Carburetor out of adjustment.</li> <li>10. Engine valves out of adjustment.</li> </ol>	<ol style="list-style-type: none"> <li>1. Fill fuel tank.</li> <li>2. See "TO START ENGINE" in Operation section.</li> <li>3. Wait several minutes before attempting to start.</li> <li>4. Replace spark plug.</li> <li>5. Clean/replace air filter.</li> <li>6. Replace fuel filter.</li> <li>7. Drain fuel tank and carburetor, refill tank with fresh gasoline and replace fuel filter.</li> <li>8. Check all wiring.</li> <li>9. Contact an authorized service center/department.</li> <li>10. Contact an authorized service center/department.</li> </ol>
<b>Hard to start</b>	<ol style="list-style-type: none"> <li>1. Dirty air filter.</li> <li>2. Bad spark plug.</li> <li>3. Weak or dead battery.</li> <li>4. Dirty fuel filter.</li> <li>5. Stale or dirty fuel.</li> <li>6. Loose or damaged wiring.</li> <li>7. Carburetor out of adjustment.</li> <li>8. Engine valves out of adjustment.</li> </ol>	<ol style="list-style-type: none"> <li>1. Clean/replace air filter.</li> <li>2. Replace spark plug.</li> <li>3. Recharge or replace battery.</li> <li>4. Replace fuel filter.</li> <li>5. Drain fuel tank and refill with fresh gasoline.</li> <li>6. Check all wiring.</li> <li>7. Contact an authorized service center/department.</li> <li>8. Contact an authorized service center/department.</li> </ol>
<b>Engine will not turn over</b>	<ol style="list-style-type: none"> <li>1. Clutch/brake pedal not depressed.</li> <li>2. Attachment clutch is engaged.</li> <li>3. Weak or dead battery.</li> <li>4. Blown fuse.</li> <li>5. Corroded battery terminals.</li> <li>6. Loose or damaged wiring.</li> <li>7. Faulty ignition switch.</li> <li>8. Faulty solenoid or starter.</li> <li>9. Faulty operator presence switch(es).</li> </ol>	<ol style="list-style-type: none"> <li>1. Depress clutch/brake pedal.</li> <li>2. Disengage attachment clutch.</li> <li>3. Recharge or replace battery.</li> <li>4. Replace fuse.</li> <li>5. Clean battery terminals.</li> <li>6. Check all wiring.</li> <li>7. Check/replace ignition switch.</li> <li>8. Check/replace solenoid or starter.</li> <li>9. Contact an authorized service center/department.</li> </ol>
<b>Engine clicks but will not start</b>	<ol style="list-style-type: none"> <li>1. Weak or dead battery.</li> <li>2. Corroded battery terminals.</li> <li>3. Loose or damaged wiring.</li> <li>4. Faulty solenoid or starter.</li> </ol>	<ol style="list-style-type: none"> <li>1. Recharge or replace battery.</li> <li>2. Clean battery terminals.</li> <li>3. Check all wiring.</li> <li>4. Check/replace solenoid or starter.</li> </ol>
<b>Loss of power</b>	<ol style="list-style-type: none"> <li>1. Cutting too much grass/too fast.</li> <li>2. Throttle in "CHOKE" position.</li> <li>3. Build-up of grass, leaves and trash under mower.</li> <li>4. Dirty air filter.</li> <li>5. Low oil level/dirty oil.</li> <li>6. Faulty spark plug.</li> <li>7. Dirty fuel filter.</li> <li>8. Stale or dirty fuel.</li> <li>9. Water in fuel.</li>   <li>10. Spark plug wire loose.</li> <li>11. Dirty engine air screen/fins.</li> <li>12. Dirty/clogged muffler.</li> <li>13. Loose or damaged wiring.</li> <li>14. Carburetor out of adjustment.</li> <li>15. Engine valves out of adjustment.</li> </ol>	<ol style="list-style-type: none"> <li>1. Set in "Higher Cut" position/reduce speed.</li> <li>2. Adjust throttle control.</li> <li>3. Clean underside of mower housing.</li> <li>4. Clean/replace air filter.</li> <li>5. Check oil level/change oil.</li> <li>6. Clean and regap or change spark plug.</li> <li>7. Replace fuel filter.</li> <li>8. Drain fuel tank and refill with fresh gasoline.</li> <li>9. Drain fuel tank and carburetor, refill tank with fresh gasoline and replace fuel filter.</li> <li>10. Connect and tighten spark plug wire.</li> <li>11. Clean engine air screen/fins.</li> <li>12. Clean/replace muffler.</li> <li>13. Check all wiring.</li> <li>14. Contact an authorized service center/department.</li> <li>15. Contact an authorized service center/department.</li> </ol>
<b>Excessive vibration</b>	<ol style="list-style-type: none"> <li>1. Worn, bent or loose blade.</li> <li>2. Bent blade mandrel.</li> <li>3. Loose/damaged part(s).</li> </ol>	<ol style="list-style-type: none"> <li>1. Replace blade. Tighten blade bolt.</li> <li>2. Replace blade mandrel.</li> <li>3. Tighten loose part(s). Replace damaged parts.</li> </ol>

# TROUBLESHOOTING POINTS

PROBLEM	CAUSE	CORRECTION
<b>Engine continues to run when operator leaves seat with attachment clutch engaged</b>	<ol style="list-style-type: none"> <li>1. Faulty operator-safety presence control system.</li> </ol>	<ol style="list-style-type: none"> <li>1. Check wiring, switches and connections. If not corrected, contact an authorized service center/department.</li> </ol>
<b>Poor cut - uneven</b>	<ol style="list-style-type: none"> <li>1. Worn, bent or loose blade</li> <li>2. Mower deck not level.</li> <li>3. Buildup of grass, leaves, and trash under mower.</li> <li>4. Bent blade mandrel.</li> <li>5. Clogged mower deck vent holes from buildup of grass, leaves, and trash around mandrels.</li> </ol>	<ol style="list-style-type: none"> <li>1. Replace blade. Tighten blade bolt.</li> <li>2. Level mower deck.</li> <li>3. Clean underside of mower housing.</li> <li>4. Replace blade mandrel.</li> <li>5. Clean around mandrels to open vent holes.</li> </ol>
<b>Mower blades will not rotate</b>	<ol style="list-style-type: none"> <li>1. Obstruction in clutch mechanism.</li> <li>2. Worn/damaged mower drive belt.</li> <li>3. Frozen idler pulley.</li> <li>4. Frozen blade mandrel.</li> </ol>	<ol style="list-style-type: none"> <li>1. Remove obstruction.</li> <li>2. Replace mower drive belt.</li> <li>3. Replace idler pulley.</li> <li>4. Replace blade mandrel.</li> </ol>
<b>Poor grass discharge</b>	<ol style="list-style-type: none"> <li>1. Engine speed too slow.</li> <li>2. Travel speed too fast.</li> <li>3. Wet grass.</li> <li>4. Mower deck not level.</li> <li>5. Low/uneven tire air pressure.</li> <li>6. Worn, bent or loose blade.</li> <li>7. Buildup of grass, leaves and trash under mower.</li> <li>8. Mower drive belt worn.</li> <li>9. Blades improperly installed.</li> <li>10. Improper blades used.</li> <li>11. Clogged mower deck vent holes from buildup of grass, leaves, and trash around mandrels.</li> </ol>	<ol style="list-style-type: none"> <li>1. Place throttle control in "FAST" position.</li> <li>2. Shift to slower speed.</li> <li>3. Allow grass to dry before mowing.</li> <li>4. Level mower deck.</li> <li>5. Check tires for proper air pressure.</li> <li>6. Replace/sharpen blade. Tighten blade bolt.</li> <li>7. Clean underside of mower housing.</li> <li>8. Replace mower drive belt.</li> <li>9. Reinstall blades sharp edge down.</li> <li>10. Replace with blades listed in this manual.</li> <li>11. Clean around mandrels to open vent holes.</li> </ol>
<b>Headlight(s) not working (if so equipped)</b>	<ol style="list-style-type: none"> <li>1. Switch is "OFF".</li> <li>2. Bulb(s) burned out.</li> <li>3. Faulty light switch.</li> <li>4. Loose or damaged wiring.</li> <li>5. Blown fuse.</li> </ol>	<ol style="list-style-type: none"> <li>1. Turn switch "ON".</li> <li>2. Replace bulb(s).</li> <li>3. Check/replace light switch.</li> <li>4. Check wiring and connections.</li> <li>5. Replace fuse.</li> </ol>
<b>Battery will not charge</b>	<ol style="list-style-type: none"> <li>1. Bad battery cell(s).</li> <li>2. Poor cable connections.</li> <li>3. Faulty regulator (if so equipped).</li> <li>4. Faulty alternator.</li> </ol>	<ol style="list-style-type: none"> <li>1. Replace battery.</li> <li>2. Check/clean all connections.</li> <li>3. Replace regulator.</li> <li>4. Replace alternator.</li> </ol>
<b>Engine "backfires" when turning engine "OFF"</b>	<ol style="list-style-type: none"> <li>1. Engine throttle control not set at "SLOW" position for 30 seconds before stopping engine.</li> </ol>	<ol style="list-style-type: none"> <li>1. Move throttle control to "SLOW" position and allow to idle for 30 seconds before stopping engine.</li> </ol>

# 14 HP 42" TRACTOR - - MODEL NUMBER 917.254850

## SCHEMATIC

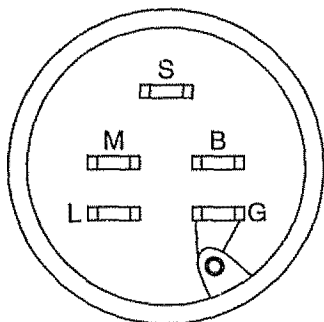
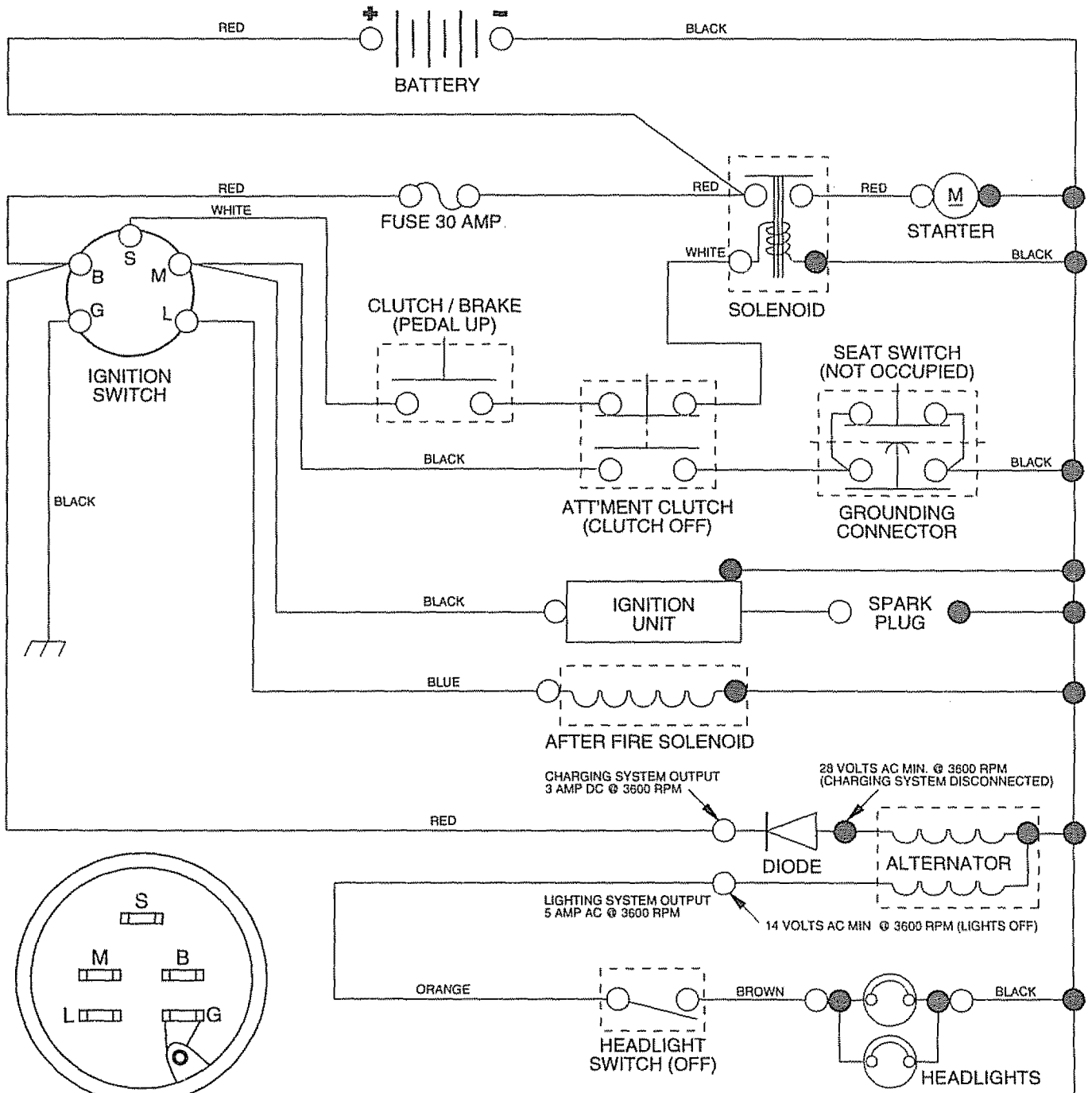

**IGNITION SWITCH**

POSITION	CIRCUIT
OFF	M + G
ON	B + L
START	B + S + L

### WIRING INSULATED CLIPS

**NOTE:** IF WIRING INSULATED CLIPS WERE REMOVED FOR SERVICING OF UNIT, THEY SHOULD BE REPLACED TO PROPERLY SECURE YOUR WIRING

### NOTE

YOUR TRACTOR IS EQUIPPED WITH A SPECIAL ALTERNATOR SYSTEM. THE LIGHTS ARE NOT CONNECTED TO THE BATTERY, BUT HAVE THEIR OWN ELECTRICAL SOURCE. BECAUSE OF THIS, THE BRIGHTNESS OF THE LIGHTS WILL CHANGE WITH ENGINE SPEED. AT IDLE THE LIGHTS WILL DIM. AS THE ENGINE IS SPEEDED UP, THE LIGHTS WILL BECOME THEIR BRIGHTEST.



# REPAIR PARTS

14 HP 42" TRACTOR -- MODEL NUMBER 917.254850

## ELECTRICAL

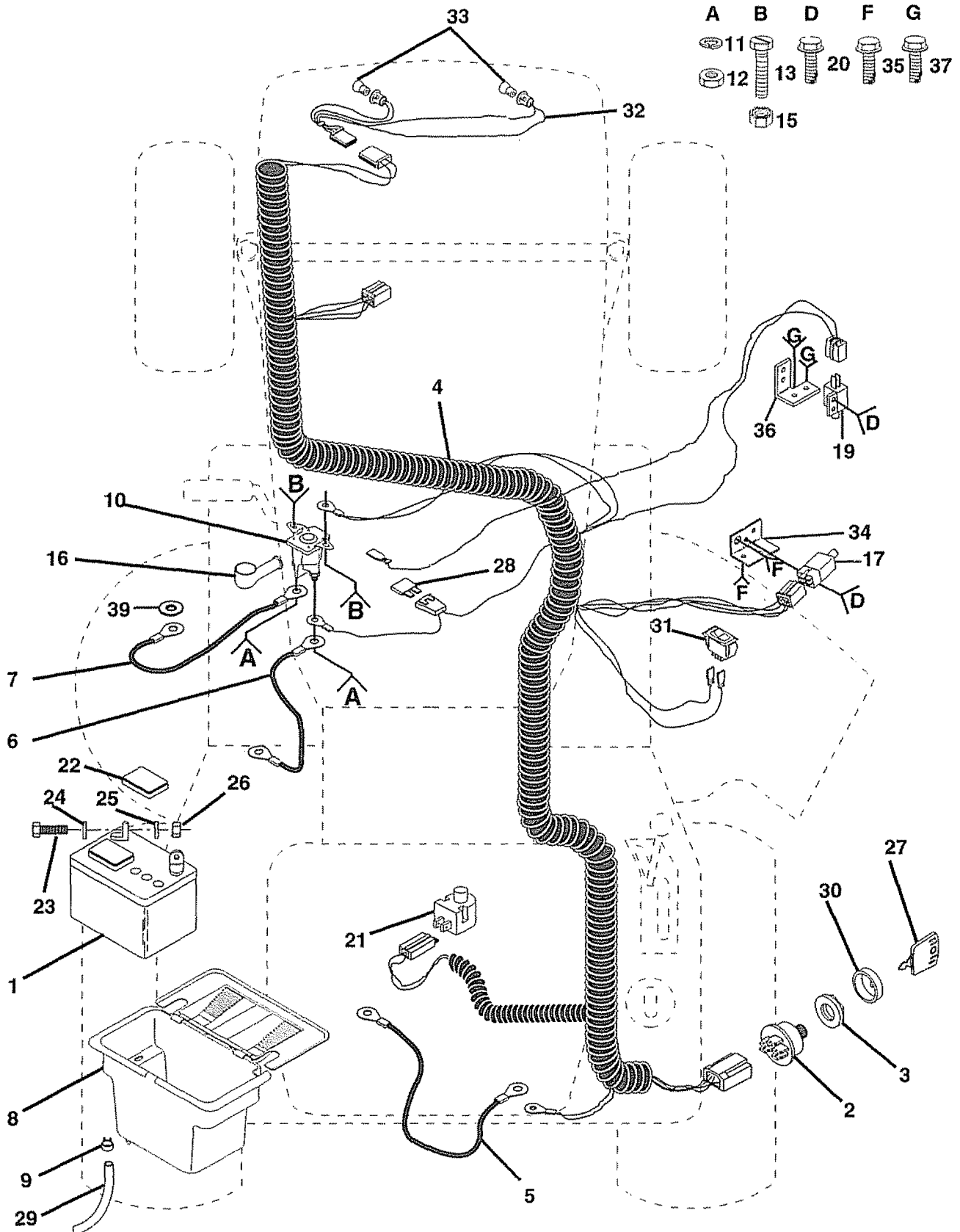

# REPAIR PARTS

14 HP 42" TRACTOR - - MODEL NUMBER 917.254850

## ELECTRICAL

KEY PART NO.	NO.	DESCRIPTION
1	121265X	Battery 12 Volt 25 Amp
2	102972X	Switch Ignition
3	124211X	Nut Ignition
4	138088	Harness Ign KOH Fender HI
5	4207J	Cable Ground 6ga 12"black
6	132202	Cable Battery 6 Ga 43"red
7	4799J	Cable Battery 6ga 11"red
8	129965	Case Battery Hng Mech W/lid
9	109596X	Clamp Hose Olive
10	138406	Solenoid
11	STD551125	Lockwasher
12	73350400	Nut Jam Hex 1/4-20 Unc
13	71110408	Bolt Fin Hex 1/4-20uncx1/2 Gr5
15	STD541425	Nut
16	131563	Cover Terminal Red
17	109553X	Switch Intlk Clutch Red 4 Term
19	104445X	Switch Intlk Clutch Red 2 Term
20	STD601005	Screw
21	121305X	Switch Plunger Nc Gray
22	121264X	Caps Battery 20/25/30 Amp
23	74760412	Bolt Hex Hd 1/4-20unc X 3/4
24	STD551025	Washer
25	STD551125	Washer
26	STD541025	Nut
27	109310X	Key Ign Molded Craftsman
28	108824X	Fuse 30 Amp Auto Green
29	109238X	Tube Plastic 12"
30	123620X	Cover Sw Key Blk 1 25 Text Slit
31	110712X	Switch Light Blk Blk Red
32	136850	Harness Socket Light
33	4152J	Bulb Light #1141
34	108236X	Bracket Switch Clutch
35	STD601005	Screw
36	130890	Bracket Switch Interlock
37	STD601005	Screw
39	11150400	Washer Lock Int. Tooth 1/4

**NOTE:** All component dimensions given in U.S. inches  
1 inch = 25.4 mm

# REPAIR PARTS

14 HP 42" TRACTOR - - MODEL NUMBER 917.254850

## CHASSIS AND ENCLOSURES

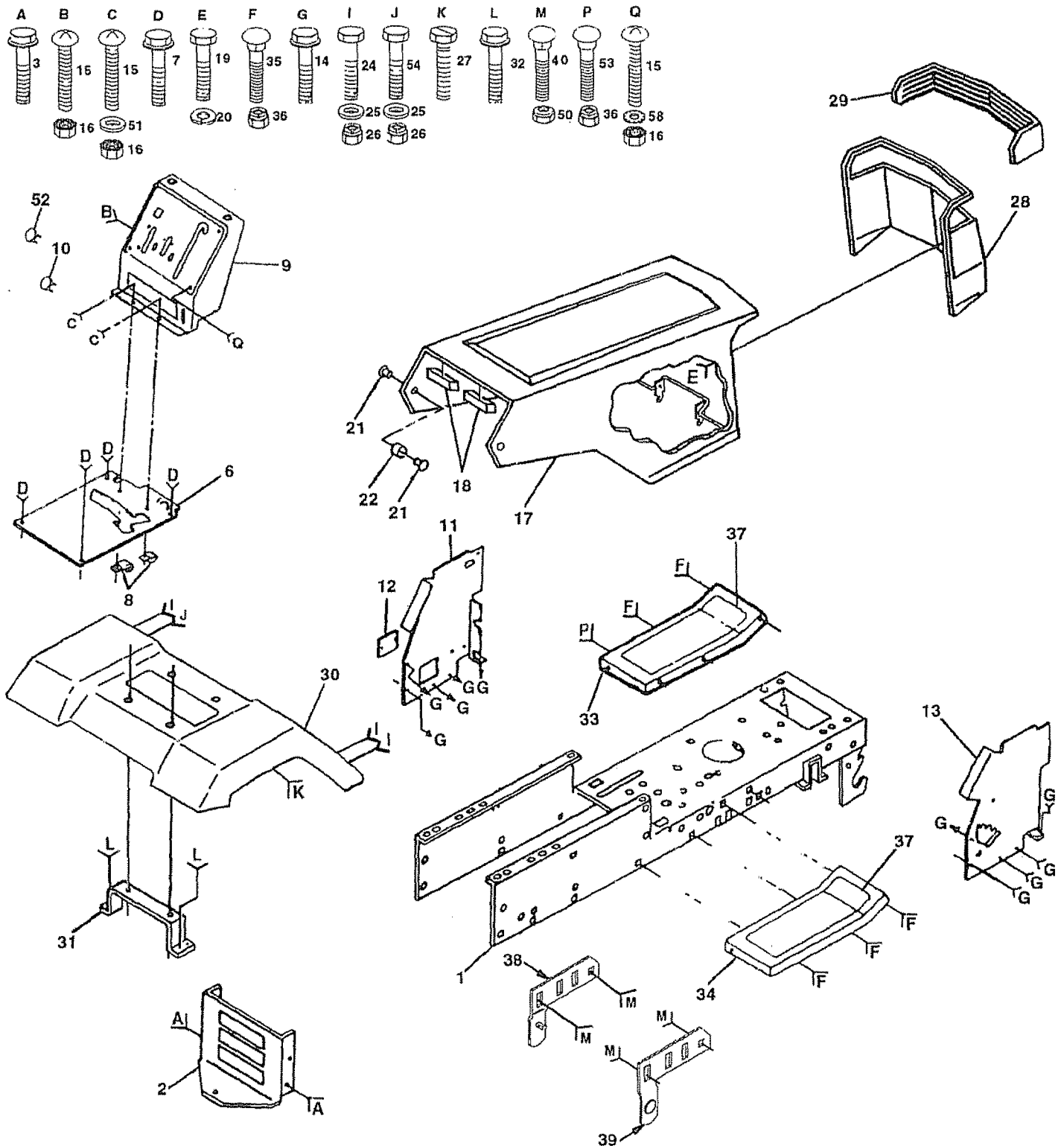



# REPAIR PARTS

14 HP 42" TRACTOR - - MODEL NUMBER 917.254850

## CHASSIS AND ENCLOSURES

KEY NO.	PART NO.	DESCRIPTION
1	135034	Chassis Weldment
2	130805	Drawbar 11 Ga 46 5"wheel Base
3	17490612	Screw Thdrol 3/8-16x3/4 Ty-tt
6	126595X014	Saddle Silkscreened
7	17490608	Screw Thdrol 3/8-16x1/2 Ty-tt
8	126471X	Clip Insulated 406 Mtg Hole
9	137411X015	Dash Silkscreened Eng
10	5479J	Plug Button Blk 359 Dia
11	122795X	Panel Pnt Dash Lh
12	121794X	Cover Access Black Square
13	126276X	Panel Dash Rh Weldment
14	17490608	Screw Thdrol 3/8-16x1/2 Ty-tt
15	74180512	Screw Mach Trhd 5/16-18uncx3/4
16	STD541431	Nut
17	131445X459	Hood Asm Pnt Weld Dover Slpe
18	126938X	Bumper Hood
19	STD512505	Screw
20	STD551125	Washer
21	122933X	Rivet Ratchet Nylon
22	124479X	Washer Nylon Blk 28x 75x 19
24	STD523707	Bolt
25	19131312	Washer 13/32 X 13/16 X 12 Ga
26	STD541437	Nut
27	17490608	Screw Thdrol 3/8-16x1/2 Ty-tt
28	126741X	Grille Black
29	124029X	Lens Headlight Bar Clear
30	126599X459	Fender Pnt
31	136619	Bracket Pnt Fender
32	17490612	Screw Thdrol 3/8-16x3/4 Ty-tt
33	105465X459	Footrest Pnt Lh
34	105464X459	Footrest Pnt Rh (dover Gray)
35	STD533707	Bolt
36	STD541437	Nut
37	105466X	Pad Footrest Rbr Sq Craftsman
38	134774	Bracket, Assembly, Pivot L.H.
39	134775	Bracket, Assembly, Pivot R.H.
40	STD533707	Bolt Carriage 3/8-16 x 3/4
50	STD541437	Locknut Hex w/Wsh 3/8-16 Unc
51	19131216	Washer 13/32 x 3/4 x 16 Ga.
52	134014	Plug Dome Black
53	72140608	Bolt, Carriage 3/8-16 UNC x 1
54	74760614	Bolt, Hex 3/8-16 x 7/8

**NOTE:** All component dimensions given in U.S. inches

1 inch = 25.4 mm

# REPAIR PARTS

14 HP 42" TRACTOR - - MODEL NUMBER 917.254850

## DRIVE

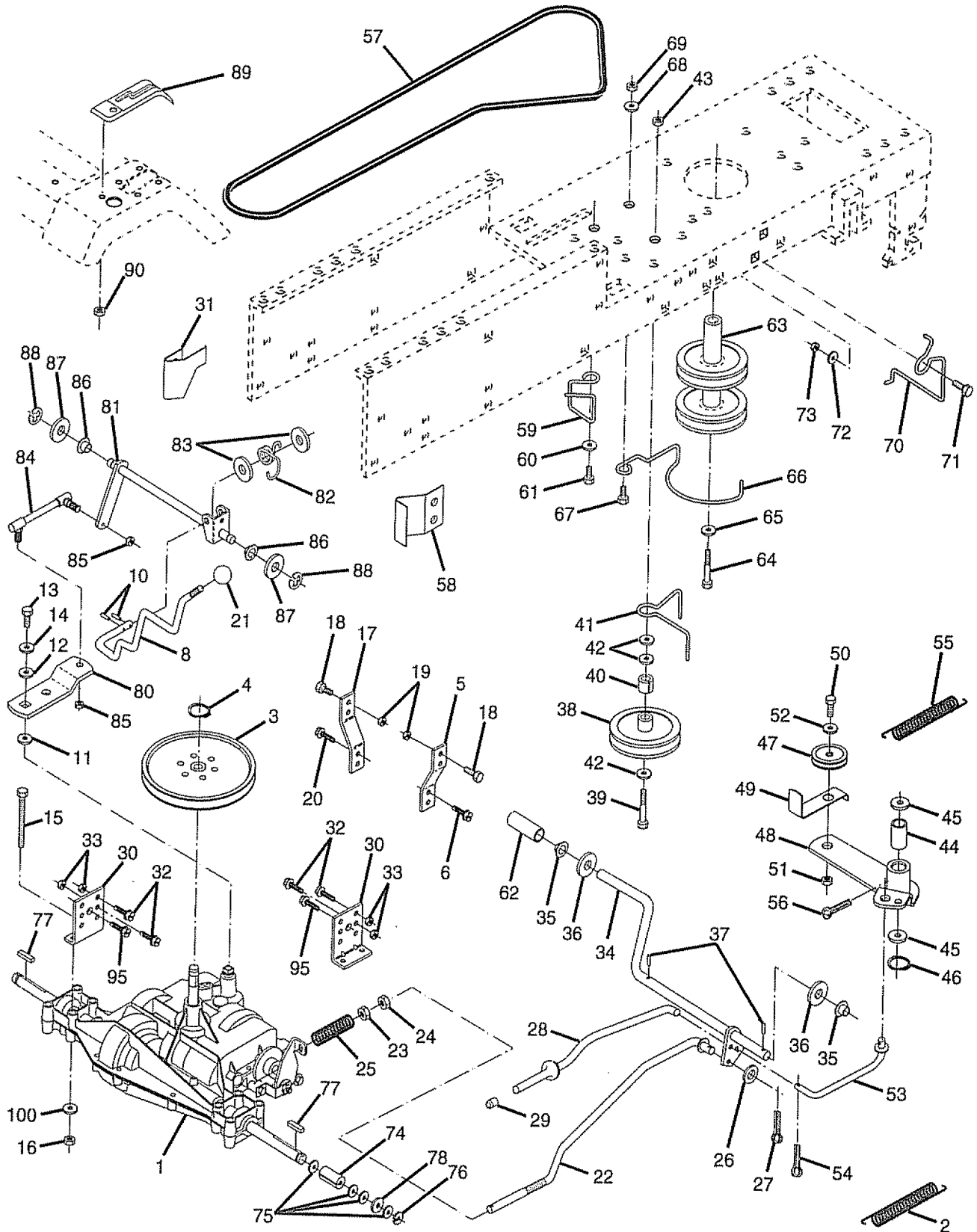

# REPAIR PARTS

## 14 HP 42" TRACTOR - - MODEL NUMBER 917.254850

### DRIVE

KEY NO.	PART NO.	DESCRIPTION	KEY NO.	PART NO.	DESCRIPTION
1	137363	Transaxle 6 sp. Dana 4360-48	50	STD523715	Bolt
2	110422X	Spring Extension Brake	51	STD541437	Nut
3	123666X	Pulley Transaxle 18" tires	52	STD551037	Washer
4	12000028	Ring Retainer # 5100-62	53	105710X	Link Clutch 7 66
5	121520X	Strap Torque	54	STD561210	Pin
6	17490512	Screw Thdrol 5/16-18 X 3/4 Tyt	55	105709X	Spring Return Clutch 6 75
8	127270	Lever Shift Weld Pnt	56	STD561210	Pin
10	76020416	Pin Cotter	57	138255	V-belt Ground Drive
11	105701X	Washer Shift Plate	58	127274X	Keeper Belt Rh Lt Pnt/zinc 16g
12	19151216	Washer 15/32 x 3/4 x 16 Ga.	59	136715	Keeper Belt Chassis Span Ctr
13	71040412	Bolt Fin Hex 1/4-28unfx3/4 Gr8	60	19131312	Washer 13/32 X 13/16 X 12 Ga
14	STD551125	Washer	61	17490612	Screw Thdrol 3/8-16x3/4 Ty-tt
17	121520X	Strap Torque	62	8883R	Cover Pedal Blk Round
18	STD523707	Bolt	63	140186	Pulley Engine
19	STD541437	Nut	64	M747810100	Bolt Hex
20	17490512	Screw Thdrol 3/8-16x3/4 Ty-tt	65	STD551143	Washer
21	106933X	Knob Rd 1/2-13 Plstc Thds Blk	66	129921	Keeper Belt Engine Lh Lt
22	130804	Rod, Brake	67	STD523710	Bolt
23	STD541437	Locknut	68	19131312	Washer 13/32 X 13/16 X 12 Ga
24	STD541237	Nut	69	STD541437	Nut
25	106888X	Spring Rod Brake 2 00 Zinc	70	134683	Guide Belt Dr Mower Rh
26	STD551037	Washer	71	STD523710	Bolt
27	STD561210	Pin	72	19132012	Washer 13/32 X 1-1/4 X 12 Ga
28	128904	Rod Brake Parking Lt	73	STD541437	Nut
29	124236X	Cap Parking Brake Red	74	109502X	Spacer Split 80 X 94
30	130807	Bracket Mtg Transaxle	75	121749X	Washer 25/32 X 1 1/4 X 16 Ga
31	127275X	Keeper Belt Lh Lt 14 Ga	76	STD581075	E Ring
32	STD523107	Bolt	77	123583X	Key Square 2 0 X 1845/ 1865
33	STD541431	Nut	78	121748X	Washer 25/32 X 1 5/8 X 16ga
34	122424X	Shaft Asm Pedal Foot 1 930	80	131488	Arm, Shift
35	120183X	Bearing Nylon Blk 629 Id	81	136932	Shaft Asm., Cross Stretch
36	STD551062	Washer	82	123782X	Spring Torsion
37	STD571810	Roll Pin	83	19171216	Washer 17/32 x 3/4 x 16 Ga.
38	123674X	Pulley Idler Flat	84	132182	Rod Tie Shft. Adj. Ball
39	STD523727	Bolt	85	73530400	Nut, Nylock
40	4470J	Spacer Split 395 X 59 Bzp	86	71208	Bushing Pivot
41	109070X	Keeper Belt Retainer	87	19212016	Washer
42	19131312	Washer 13/32 X 13/16 X 12 Ga	88	12000008	Ring, E
43	STD541437	Nut	89	131636	Console Shift 6sp W/ign Lt
44	105706X	Bearing, Nylon	90	124346X	Nut Self-thd Wsh-hd 1/4 Zinc
45	110812X	Washer Hardened	91	74760540	Bolt Fin Hex 5/16-18 x 2-1/2
46	12000039	Ring Klip #t5304-50	93	STD541431	Nut
47	127783	Pulley Idler V Groove Plastic	95	17490612	Screw Thdrol 3/8 - 16 x 3/4
48	123789X	Bellcrank Asm			
49	123205X	Retainer Belt Style Spring			

**NOTE:** All component dimensions given in U.S. inches  
1 inch = 25.4 mm

# REPAIR PARTS

14 HP 42" TRACTOR - - MODEL NUMBER 917.254850

## STEERING ASSEMBLY

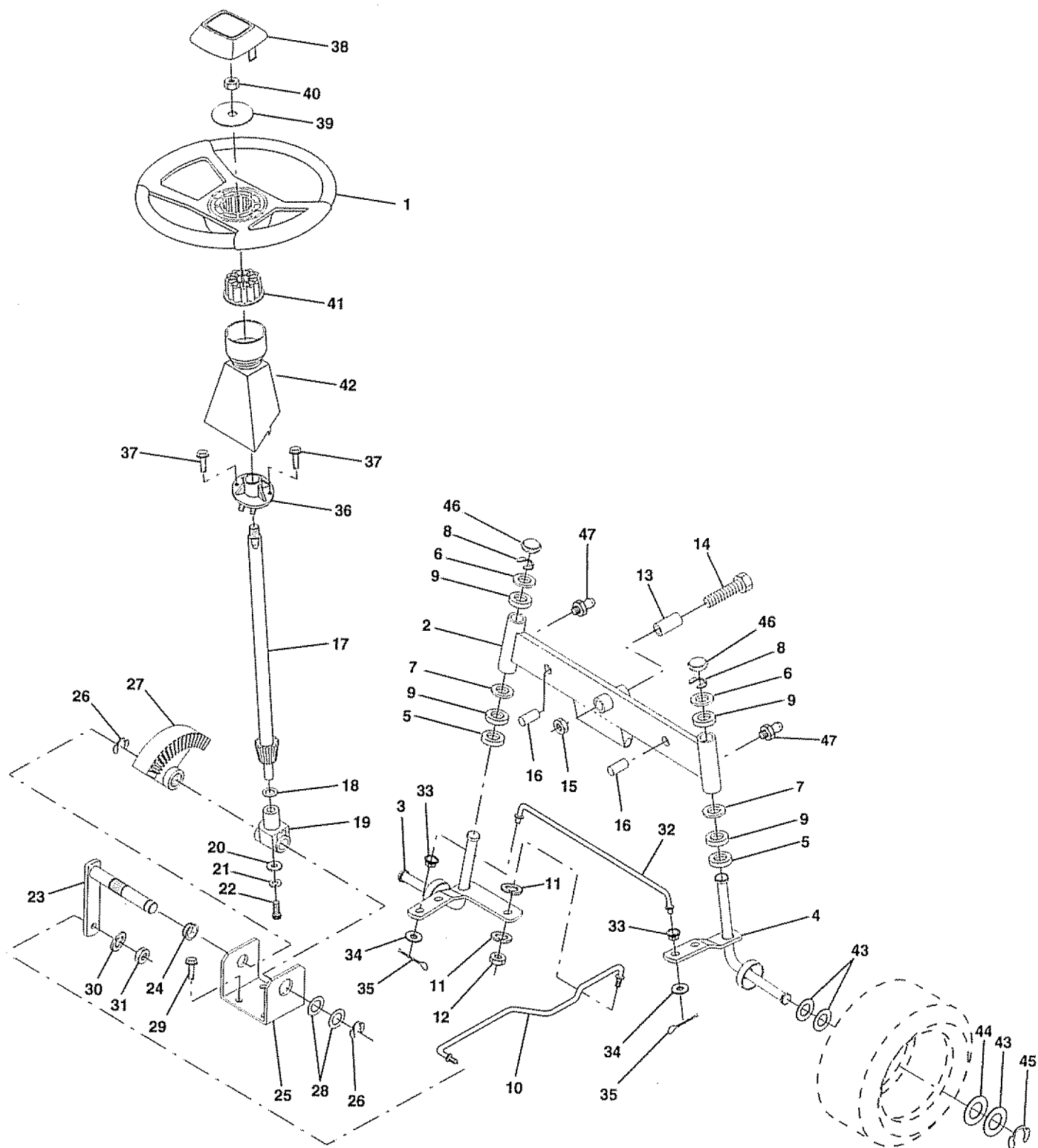

# REPAIR PARTS

14 HP 42" TRACTOR - - MODEL NUMBER 917.254850

## STEERING ASSEMBLY

KEY NO.	PART NO.	DESCRIPTION
1	121472X	Wheel Steering
2	133988	Axle Asm Front
3	135227	Spindle Asm Lh
4	135228	Spindle Asm Rh
5	6266H	Bearing Race Thrust Harden
6	121748X	Washer 25/32 X 1 5/8 X 16ga
7	19272016	Washer 27/32 X 1 1/4 X 16 Ga
8	12000029	Ring Klip #t5304-75
9	3366R	Bearing Col Strg Blk
10	130468	Link Drag Sol Ball Jt 20 064
11	STD551137	Lockwasher
12	73610600	Nut Fin Hex 3/8-24 Unf
13	110438X	Spacer Bearing Axle Front
14	74011056	Bolt Hex 5/8-11 Unc X 3-1/2
15	73901000	Nut Lock Flange 5/8-11
16	132624	Pin Axle 5/8 X 1 55/1 54 Lg
17	132614	Shaft Asm Strg 5/8 X 15 19 Lt
18	57079	Washer Thrust 515x 750x 033
19	124035X	Support Shaft
20	126684X	Washer Shim 1/4 X 5/8 X 062
21	STD551125	Washer
22	71070410	Screw Hex Socket 1/4-20 X 5/8
23	127501	Shaft Asm Pittman
24	109816X	Nyliner Snap In
25	124036X	Bracket Steering
26	12000029	Ring Klip #t5304-75
27	136874	Gear Sector
28	6266H	Bearing Race Thrust Harden
29	17490612	Screw Thdrol 3/8-16x3/4 Ty-tt
30	STD551137	Lockwasher
31	73610600	Nut Fin Hex 3/8-24 Unf
32	130465	Rod Tie Wire Form 19 75 Mech
33	126847X	Bushing Link Drag Blk
34	19131416	Washer 13/32 X 7/8 X 16ga
35	STD561210	Pin
36	132196	Bushing Strg 5/8 Id Dash
37	STD611005	Screw
38	126805X	Insert Cap Strg Wh Au Gen Blk
39	19133808	Washer 13/32 X 2-3/8 X 8 Ga
40	STD541537	Gripco Nut
41	104820X	Adaptor Wheel Strg 640/ 635id
42	124417X	Boot Shaft Steering
43	121749X	Washer 25/32 X 1 1/4 X 16 Ga
44	121748X	Washer 25/32 X 1 5/8 X 16ga
45	12000029	Ring Klip #t5304-75
46	121232X	Cap Spindle Fr Top Blk
47	6855M	Fitting Grease

**NOTE:** All component dimensions given in U.S. inches

1 inch = 25.4 mm

# REPAIR PARTS

14 HP 42" TRACTOR - - MODEL NUMBER 917.254850

## SEAT ASSEMBLY

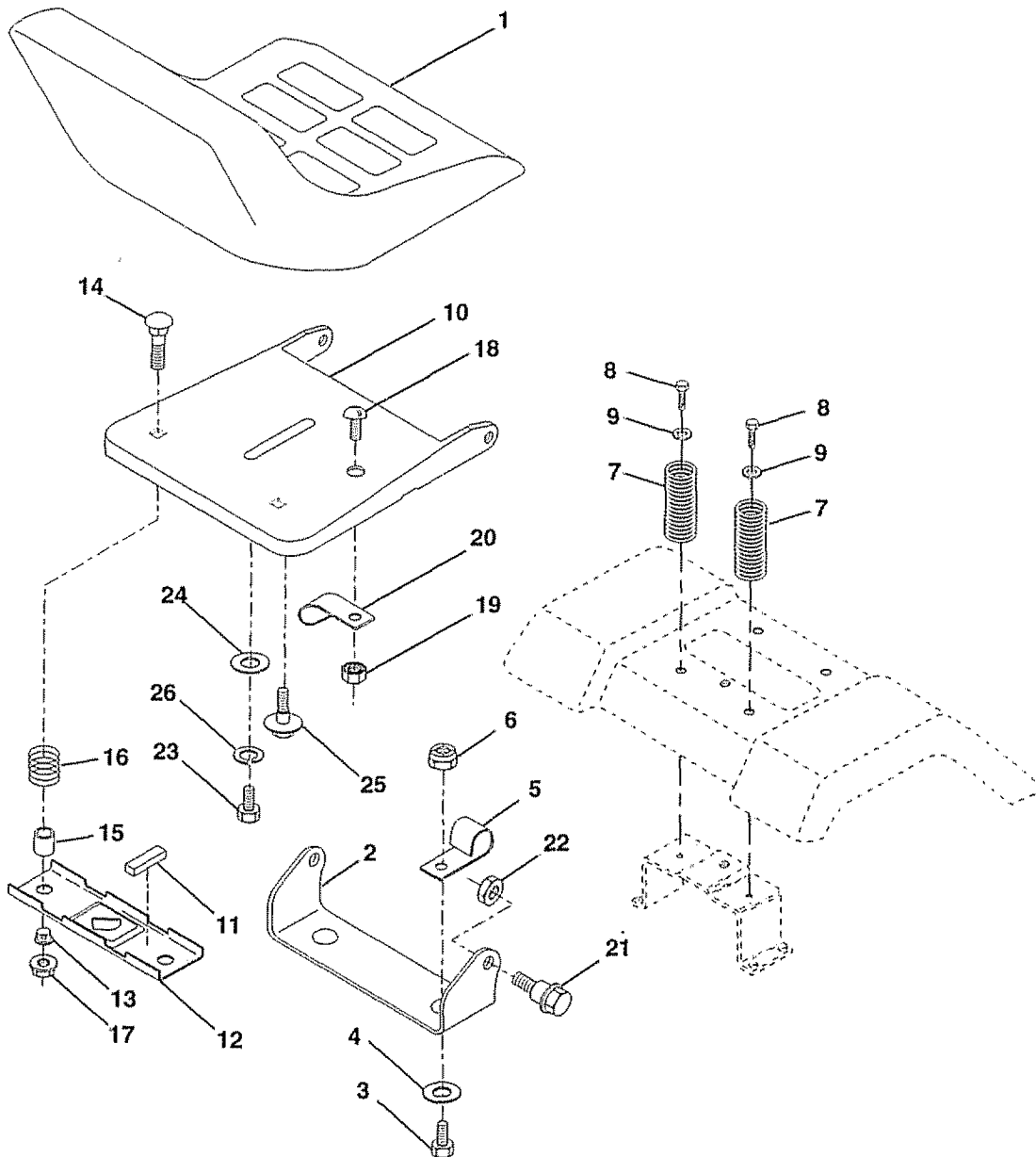

KEY NO.	PART NO.	DESCRIPTION
1	127438X	Seat V-450 Blk/red Craftsman
2	126656X	Bracket Pnt Pivot Seat (blk )
3	STD523707	Bolt
4	19131610	Washer 13/32 X 1 X 10 Ga
5	2751R	Clip Line Fuel 13/32 Mtg Hole
6	STD541437	Nut
7	124181X	Spring Seat Cprsn 2 250 Blk Zi
8	17490616	Screw Thdrol 3/8-16 X 1 Ty-tt
9	19131614	Washer 13/32 X 1 X 14 Ga
10	131451	Pan Pnt Seat (blk )
11	121251X	Strip Foam Gray Or Black
12	121246X	Bracket Pnt Mounting Switch
13	121248X	Bushing Snap Blk Nyl 50 Id
14	72050411	Bolt Rdhd Sht Nk 1/4-20x1-3/8

KEY NO.	PART NO.	DESCRIPTION
15	134300	Spacer Split 28 X 88 Zinc
16	121250X	Spring Cprsn 1 27 Blk Pnt
17	123976X	Nut Lock 1/4 Lge Flg Gr 5 Zinc
18	STD511005	Screw
19	73951000	Nut Keps #10-32 Unf
20	4171R	Clip Insulated 11/32 Mtg Hole
21	105529X	Bolt Shoulder 5/16-18 Unc Blkz
22	STD541431	Nut
23	74780814	Bolt Fin Hex 1/2-13 X 7/8 Gr 5
24	19171912	Washer 17/32 X 1-3/16 X 12 Ga
25	127018X	Bolt Shoulder 5/16-18 X 62
26	STD551150	Lockwasher

**NOTE:** All component dimensions given in U.S. inches  
1 inch = 25.4 mm

# REPAIR PARTS

## 14 HP 42" TRACTOR - - MODEL NUMBER 917.254850

### DECALS

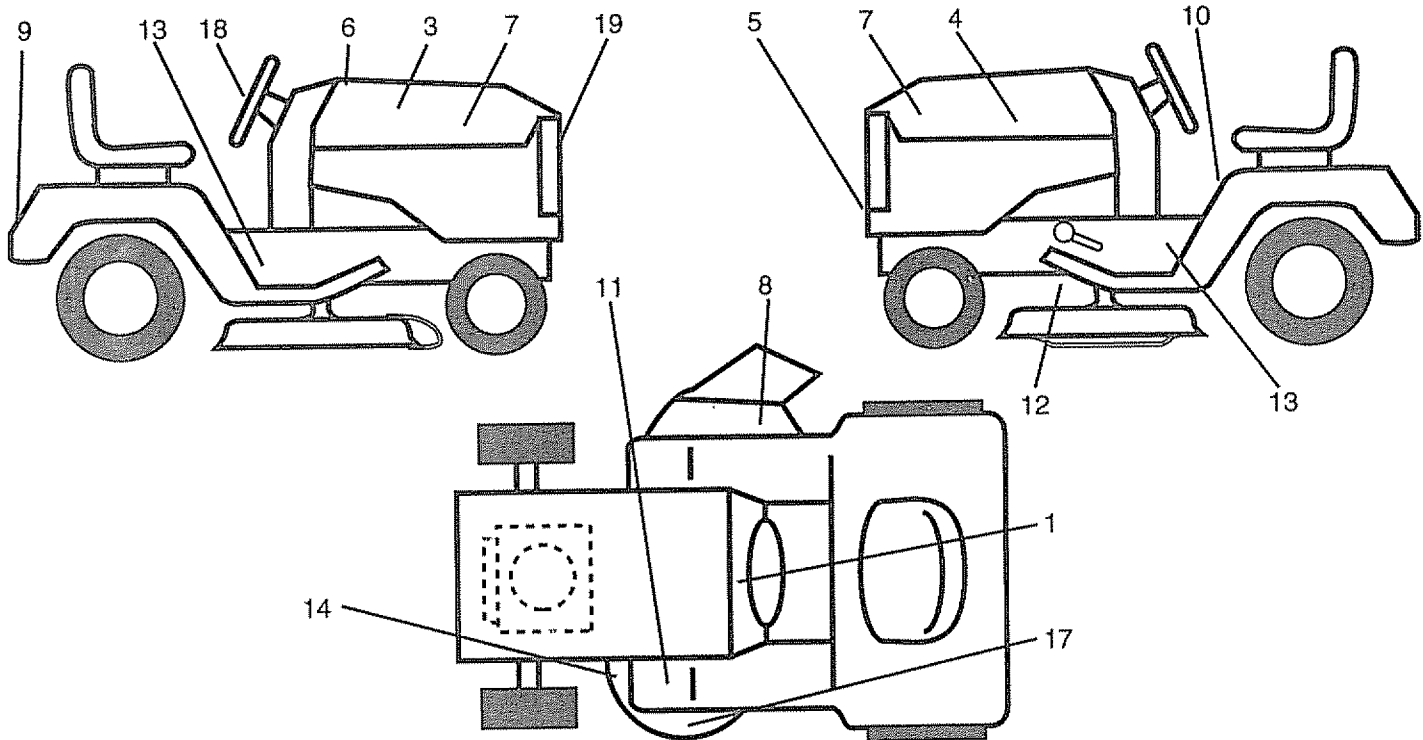

KEY NO.	PART NO.	DESCRIPTION	KEY NO.	PART NO.	DESCRIPTION
1	136794	Decal Instruction Operat Eng	12	109199X	Decal V-belt Dr Sch Tractor E
3	138137	Decal Hood Rh Craftsman Lt4000	13	131473	Decal Chassis 6sp 42"
4	128382	Decal Hood Lh Craftsman Lt4000	14	136832	Decal V-belt Schematic 42"eng
5	132674	Decal Grille Lt4000 Craft Usa	17	133179	Decal Mower Qc System
6	133644	Decal Maint Cust Sears Domesti	18	132266	Decal Insr Wh Strg Usa
7	133204	Decal Panel Side	19	131265	Decal, Lightbox Grill
8	133178	Decal Mower 3 In One Conv	--	138311	Decal, Handle Lift (Lift Handle)
9	128314	Decal Fender Craftsman White	--	137891	Manual Owners (English)
10	137537	Decal Caution English/Spanish	--	137892	Manual Owners (Spanish)
11	4900J	Decal Clutch/brake English			

**NOTE:** All component dimensions given in U.S. inches  
1 inch = 25.4 mm

### WHEELS & TIRES

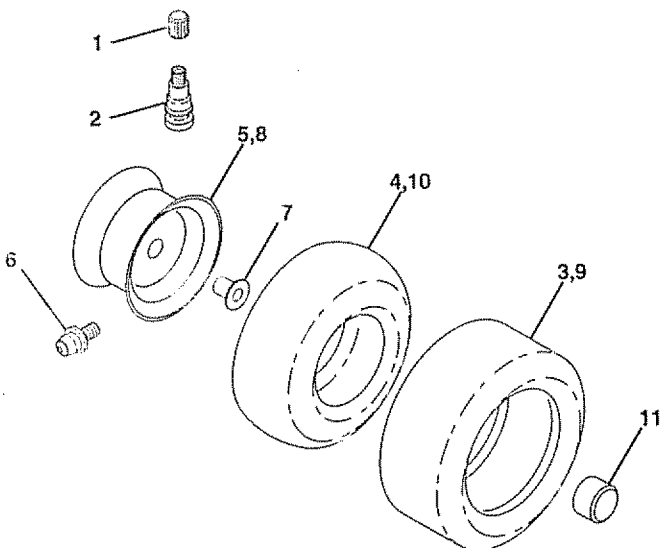

KEY NO.	PART NO.	DESCRIPTION
1	59192	Cap Valve Tire
2	65139	Stem Valve
3	106222X	Tire F Ts 15 X 6 0 - 6 Service
4	59904	Tube Front (Service Item Only)
5	106732X311	Rim Asm 6"front White Service
6	278H	Fitting Grease (Front Wheel Only)
7	9040H	Bearing Flange (Front Wheel Only)
8	106108X311	Rim Asm 8"rear White Service
9	106268X	Tire R Ts 18x9 5-8 C Service
10	7152J	Tube Rear (Service Item Only)
11	104757X	Cap Axle Blk 1 50 X 1 00

**NOTE:** All component dimensions given in U.S. inches  
1 inch = 25.4 mm

# REPAIR PARTS

14 HP 42" TRACTOR - - MODEL NUMBER 917.254850

## ENGINE

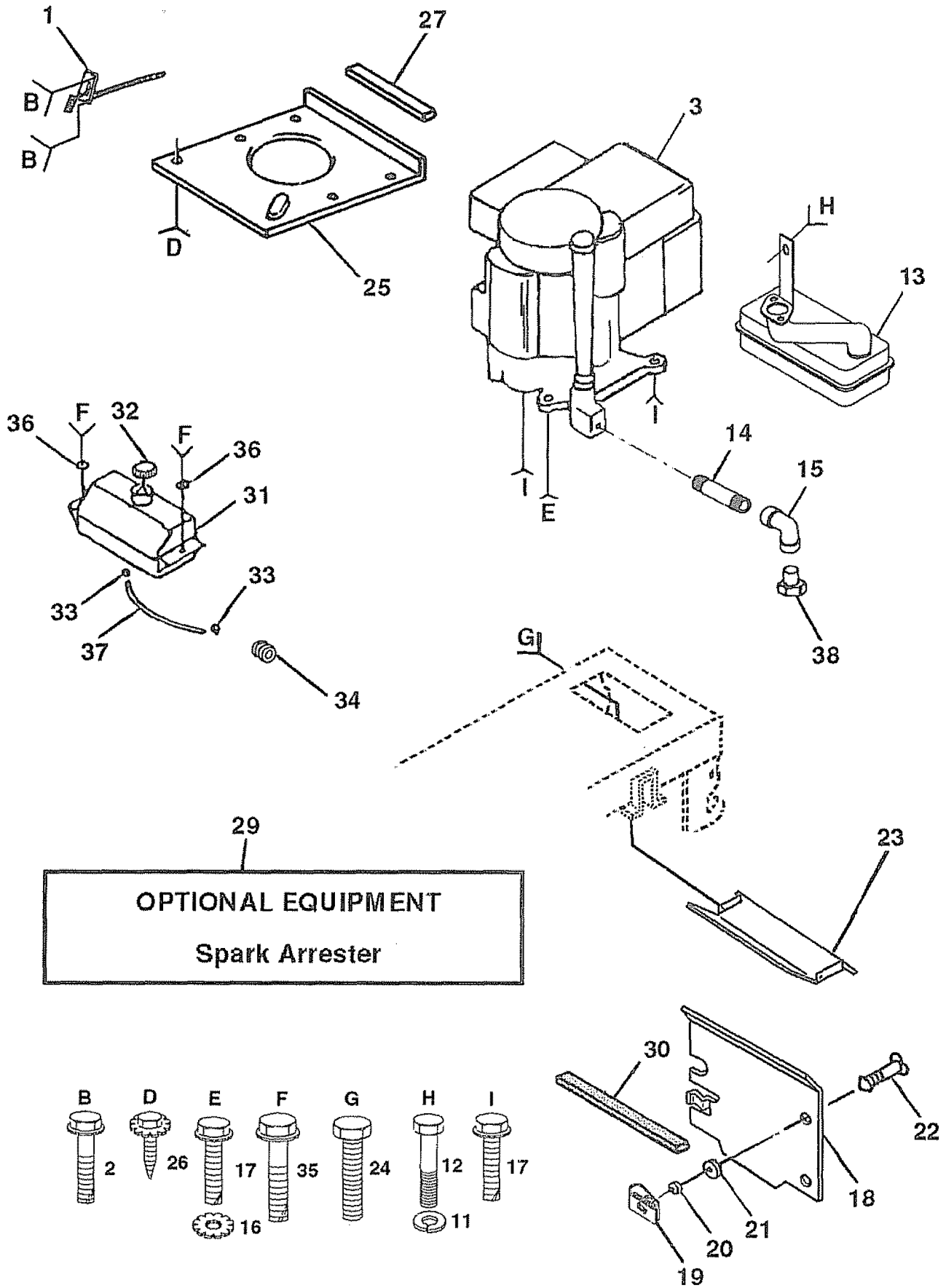



# REPAIR PARTS

## 14 HP 42" TRACTOR - - MODEL NUMBER 917.254850

### ENGINE

KEY NO.	PART NO.	DESCRIPTION
1	132760	Control Throt Ch Rh Blk Pdl 22 60
2	17720410	Screw Hex Thd Cut 1/4-20x5/8 T
3	137510	Engine, Model No. LT14S, Type No. PS1452
11	STD551131	Washer Lock Hvy Hlcl Spr 5/16
12	STD523105	Bolt Hexhd 5/16-18x1/2
13	137350	Muffler Lt Koh
14	13280328	Nipple Pipe 3/8 Npt X 3-1/2"
15	13200300	Elbow Std 90 Degree 3/8-18 Npt
16	STD551237	Washer Lock Ext Tooth 3/8
17	M740108025	Bolt Hex
18	136718	Shield Pnt Heat
19	105839X	Receptacle 1/4 Turn Dacrotized
20	105838X	Retainer 1/4 Turn 365odx 222id
21	STD551025	Washer 9/32 X 5/8 X 16 Ga
22	123650X	Stud 1/4 Turn (replaces 105751
23	128953	Shield Pnt Heat Browning Grass
24	STD601005	Screw Tap Hex #10-24unc X 1/2
25	126842X	Shield Pnt Heat Hood Lt
26	17030808	Screw Spiderloc Hexhd#8x1/2 Ab
27	105037X	Strip Foam 18"
29	137180	Arrestor Spark
30	127057X	Strap Hood
31	109202X	Tank Fuel 1 25 Fr
32	123549X	Cap Asm Fuel W/sym Vented
33	123487X	Clamp Hose Blk
34	124028X	Bushing Snap Nyl Blk Fuel Line
35	17490412	Screw Hexwsh Thdrol 1/4-20x3/4
36	19091416	Washer 9/32 X 7/8 X 16ga
37	101335K	Line Fuel 9 50"
38	---	Plug Oil Drain (Order From Engine Manufacturer)

**NOTE:** All component dimensions given in U.S. inches.  
1 inch = 25.4 mm

# REPAIR PARTS

14 HP 42" TRACTOR - - MODEL NUMBER 917.254850

## 42" MOWER DECK

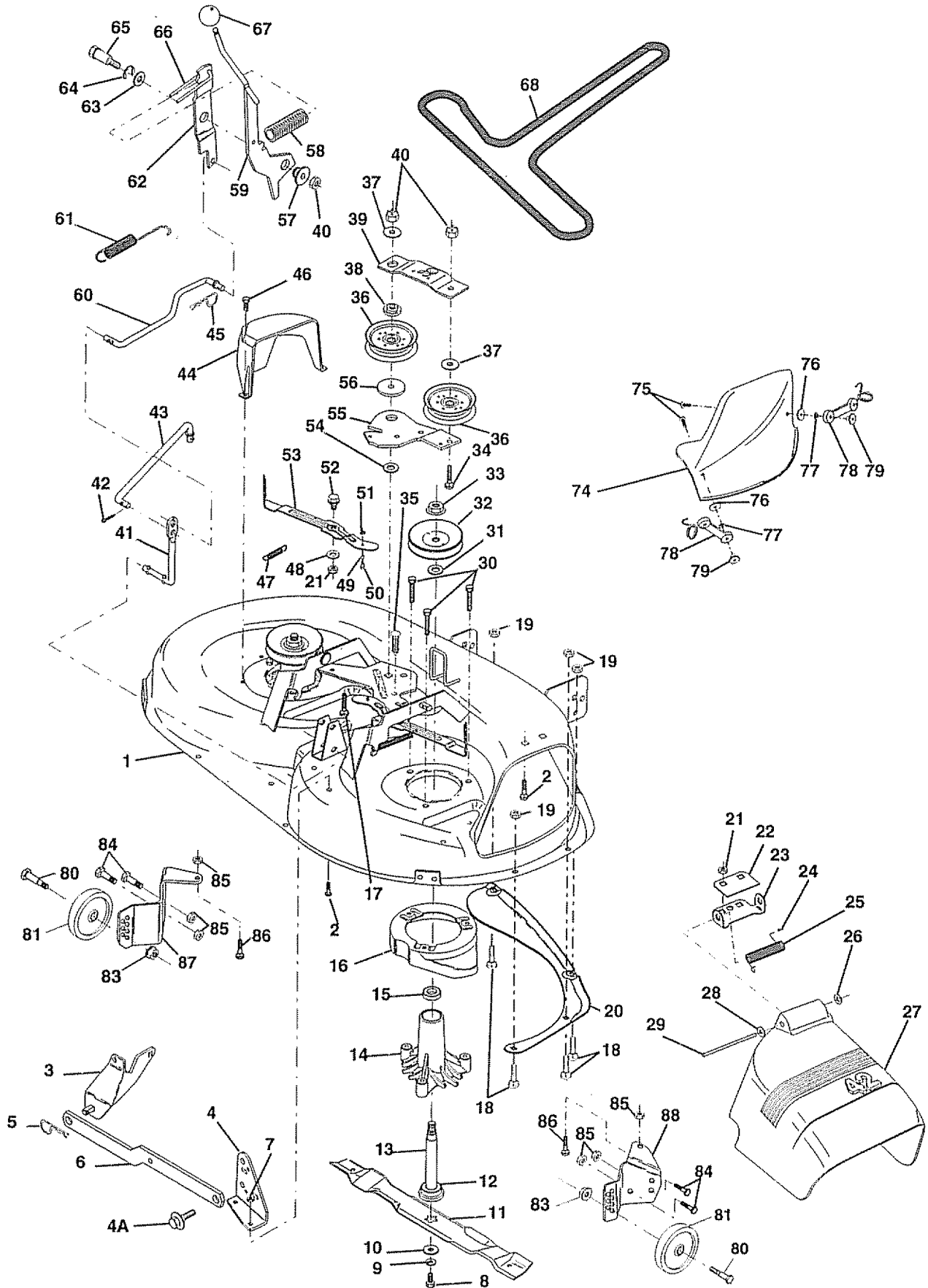

# REPAIR PARTS

## 14 HP 42" TRACTOR - - MODEL NUMBER 917.254850

### 42" MOWER DECK

KEY NO.	PART NO.	DESCRIPTION	KEY NO.	PART NO.	DESCRIPTION
1	138024	Mower Housing	45	4497H	Spring Retainer 1 Zinc/cad
2	72140506	Bolt Rdhd Sqnk 5/16-18 Unc x 3/4	46	17720410	Screw Hex Thd Cut 1/4-20 x 5/8 T
3	138017	Bracket Asm. Fr. Sway Bar	47	131335	Spring Extension
4	138440	Bracket Asm. Deck Sway Bar	48	133944	Washer Hardened Smaller
4A	132827	Bolt, Shoulder	49	133940	Roller Asm Cam Follower 42" deck
5	4939M	Retainer Spring	50	131340	Bolt Shldr 10-24 Zinc Gr5 42"
6	130832	Arm Rear Suspension	51	69180	Nut Lock #10-24 Unc
7	73800500	Locknut Hex W/Ins. 5/16-18 Unc	52	105529X	Bolt Shoulder 5/16-18 Unc Blkz
8	850857	Bolt 3/8-24 x 1 25 Gr8 Patched	53	131845	Arm Asm Pad Brake
9	10030600	Washer Lock Hvy 3/8 Unplated	54	133943	Washer Hardened
10	129962	Washer Hard Blade Mower Vented	55	133844	Arm Idler 42" mower Lt/yt
11	134149	Blade Mulching 42"	56	122052X	Spacer Retainer Pm Mower
12	129895	Bearing Ball #6204 (mandrel)	57	127498	Bushing 747 Od x 794 Lg Brass
13	137645	Shaft Asm W/lower Bearing (Inc. Key #12)	58	128759	Spring Clutch Mower 2 750 Zinc
14	128774	Housing Mandrel Vented (machd)	59	133573	Arm Asm Clutch Primary
15	110485X	Bearing Ball Mandrel	60	134666	Rod Clutch Primary
16	136929	Stripper Mower Vented	61	131870	Spring Return
17	72110618	Bolt Rdhd Sqnk 3/8-16 x 2-1/4	62	127847	Arm Clutch Secondary
18	72140505	Bolt, Carriage 5/16-18 x 5/8	63	121748X	Washer 25/32 x 1-5/8 x 16 Ga
19	73800500	Locknut Hex W/Ins. 5/16-18	64	12000029	Ring Klip #t5304-75
20	136888	Baffle Vortex	65	128903	Bolt Shoulder 3/8-16 Unc 1 44
21	73680500	Nut Crown Lock 5/16-18	66	127845	Keeper Spring 4 000
22	134753	Stiffner Bracket 42" deck	67	106932X	Knob Rd 3/8-16 Plstc Thds Blk
23	131267	Bracket Deflector Mower 42"	68	130969	V-Belt Mower 42" 92 40
24	105304X	Cap Sleeve 80 x 112 Blk Mower	74	136420	Cover Mulching 42" Blk
25	123713X	Spring Torsion Deflector 2 52	75	71161010	Screw
26	110452X	Nut Push Phos & Oil	76	19061216	Washer #10
27	130968	Shield Deflector Mower 42" Blk	77	10071000	Washer Lock #10
28	19111016	Wsher 11/32 x 5/8 x 16 Ga	78	130758	Latch Asm Bagger
29	131491	Rod Hinge 426 75 Wlg	79	2029J	Nut Weld
30	78158	Bolt 5/16-18 x 1 25 T/t	80	133814	Bolt Shoulder
31	129963	Washer Spacer Mower Vented	81	133957	Wheel Gage Donut
32	129861	Pulley Mandrel 42"	83	73930600	Nut Locking 3/8-16 Unc Blk
33	137266	Nut 9/16 top Lock Fling Oil Dip	84	74760512	Bolt Hex 5/16-18 x 3/4
34	72110614	Bolt Rdhd 3/8-16 Unc x 1-3/4 Gr5	85	73510500	Nut Keps 5/16-18
35	133835	Fastner Christmas Tree	86	72110504	Bolt Carriage 5/16-18 x 1/2
36	131494	Pulley Idler Flat 3 060	87	132263	Bracket Gage Wheel LH 42" Deck
37	19131612	Washer 13/32 x 1 x 12 Ga	88	132262	Bracket Gage Wheel RH 42" Deck
38	133502	Spacer Arm Idler Upper Hdn 42"	--	137646	Mandrel Asm Service (Includes Key Nos. 8-10, 12-15, 31 and 33)
39	133503	Stiffner Arm Idler Upper 42"	--	138357	Deck Serv 42" Mech Vent (Std. Deck -Order Separately mulching and gauge wheel components key nos. 74-88)
40	73680600	Nut Crownlock 3/8-16 Unc			
41	133551	Rod Pivot W/nibs			
42	76020312	Pin Cotter 3/32 x 3/4 Cad			
43	133504	Rod Clutch Secondary W/nibs			
44	134236	Guard Mandrel Lh Black			

**NOTE:** All component dimensions given in U.S. inches  
1 inch = 25.4 mm

# REPAIR PARTS

14 HP 42" TRACTOR - - MODEL NUMBER 917.254850

LIFT

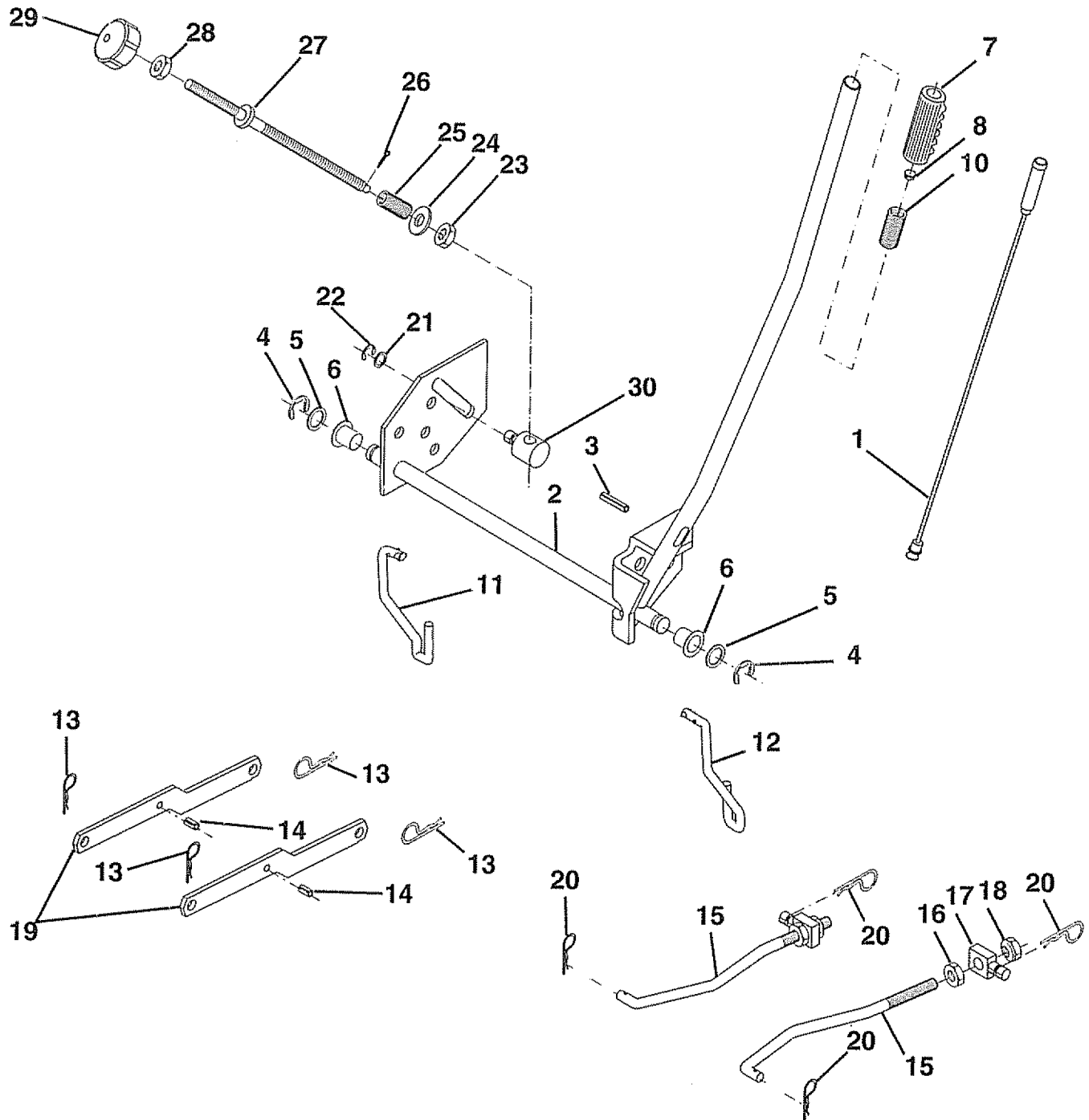

# REPAIR PARTS

14 HP 42" TRACTOR - - MODEL NUMBER 917.254850

## LIFT

KEY NO.	PART NO.	DESCRIPTION
1	136973	Wire Asm Inner W/Plunger
2	122507X	Shaft Asm. Lift
3	105767X	Pin Groove
4	STD581062	E Ring #5133-62
5	19211621	Washer 21/32 x 1 x 21 Ga.
6	120183X	Bearing Nylon
7	125631X	Grip Handle Fluted
8	122365X	Button Plunger Read
10	122512X	Spring Cprsn
11	134619	Link Lift Lh Fixed Length
12	135388	Link Lift Rh Fixed Length
13	STD624008	Retainer Spring
14	135563	Pin Roll Slf 5/16 x 1.25
15	127218	Link Front
16	73350800	Nut Jam Hex 1/2-13 Unc
17	130171	Trunnion Blk Zinc
18	STD541450	Nut Lock W/Wsh 1/2-13 Unc
20	3146R	Retainer Spring
19	130832	Arm Suspension Rear
21	19151216	Washer 15/32 x 3/4 x 16 Ga.
22	12000037	Ring Klip #T5304-37
23	110807X	Nut Special
24	STD551037	Washer 13/32 x 5/8 x 16 Ga.
25	2876H	Spring 2-1/8"
26	STD560907	Pin Cotter 3/32 x 1/2
27	126971X	Rod Adj. Lift
28	STD541237	Nut Hex Jam 3/8-16 Unc
29	138057	Knob Inf. 3/8-16 Unc Blk w/Sym
30	110810X	Trunnion Dp Stop Dbl Thds Plt

# REPAIR PARTS

14 HP 42" TRACTOR - - MODEL NUMBER 917.254850

DANA TRANSAXLE - MODEL NUMBER 4360-48

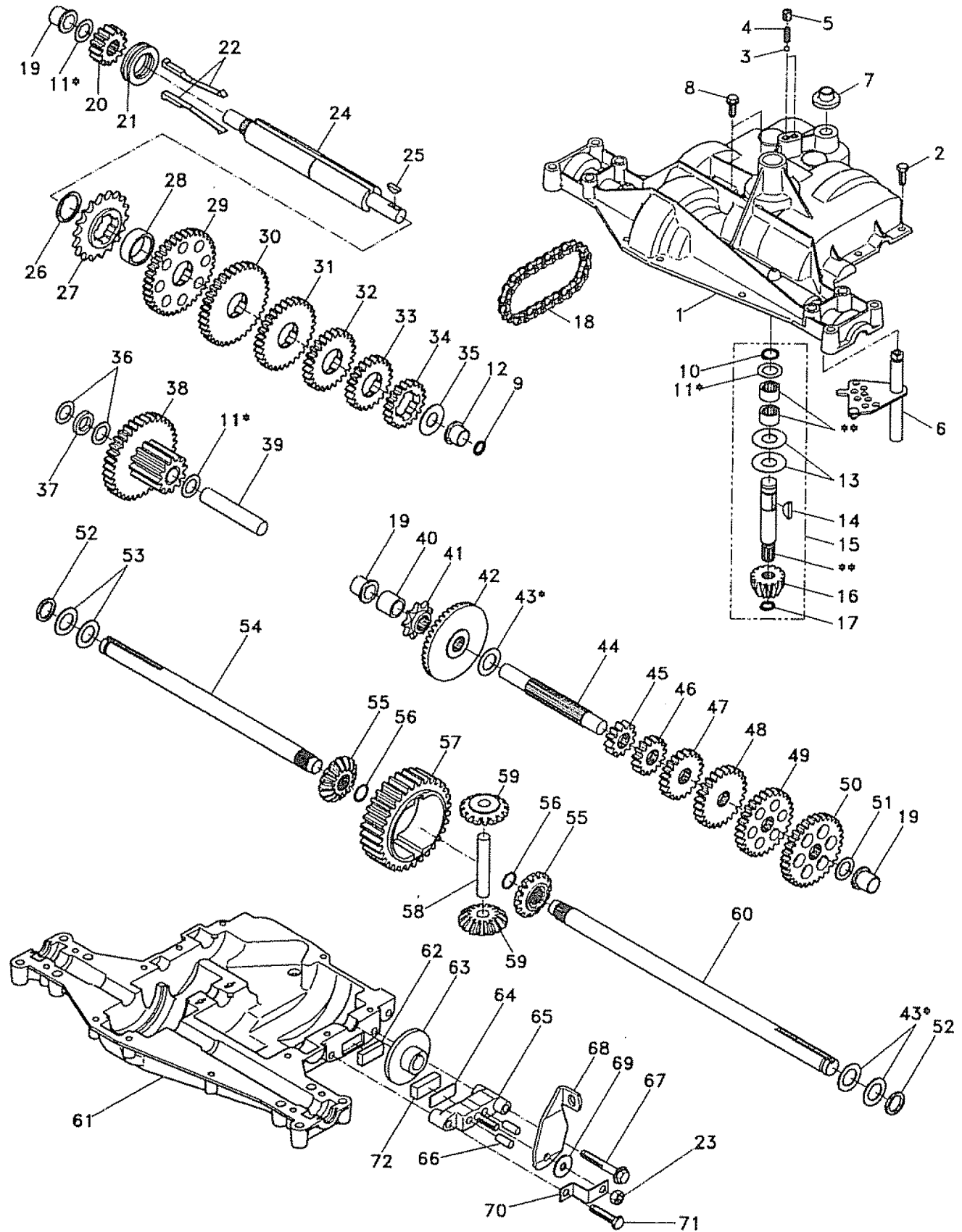

# REPAIR PARTS

## 14 HP 42" TRACTOR - - MODEL NUMBER 917.254850

### DANA TRANSAXLE - MODEL NUMBER 4360-48

KEY PART NO. NO.	DESCRIPTION	KEY PART NO. NO.	DESCRIPTION
1 138248	Housing, Upper	41 105928X	Sprocket, 9 Teeth
2 2274J	Screw, Self-Tapping, Large 1/4-20 x .734	42 110084X	Gear, Bevel, 42 Teeth
3 134400	Ball, Detent	43 134394	* Assembly, Kit, Shim .750 Shaft
4 105904X	Spring, Detent	44 120473X	Shaft, Drive
5 105905X	Screw, Set	45 105933X	Gear, Spur, 12 Teeth
6 138235	Kit, Shifter Assembly	46 106151X	Gear, Spur, 15 Teeth
7 134399	Boot, Shifter	47 120407X	Gear, Spur, 20 Teeth
8 134791	Screw, Tapping w/Sealer	48 106589X	Gear, Spur, 25 Teeth
9 138241	Square Ring	49 120408X	Gear, Spur, 28 Teeth
10 2267J	Ring, Retaining	50 105937X	Gear, Spur, 31 Teeth
11 134793	* Assembly, Kit, Shim .625 Shaft	51 2226J	Washer, Plain .632 x 1.00 x .060
12 138240	Bearing, Flange	52 134401	Washer, Neoprene
13 120415X	Washer, Plain .632 x 1.38 x .046	53 2264J	Washer, Plain .758 x 1.25 x .031
14 2257J	Key, Woodruff, #9	54 120474X	Axle, L.H.
15 138234	Assembly, Kit, Input Shaft	55 110081X	Gear, Miter, 15 Teeth
16 110078X	Pinion, Bevel, 14 Teeth	56 105941X	Ring, Retaining
17 105909X	Ring, Retaining	57 110071X	Gear, Spur, 32 Teeth
18 105910X	Chain, 24 Pitches	58 120952X	Shaft, Cross
19 105911X	Bearing, Flange	59 110082X	Gear, Miter, 15 Teeth
20 138242	Gear, Spur, 14 Teeth	60 120475X	Axle, R.H.
21 138246	Collar, Clutch	61 138247	Housing, Lower
22 138236	Assembly, Kit, Clutch Keys	62 120961X	Puck, Friction
23 73810500	Locknut 5/16-24	63 7294J	Disc, Brake
24 138243	Shaft, Intermediate	64 108989X	Spacer
25 2244J	Key, Woodruff, #61	65 120953X	Jaw, Brake
26 105916X	Ring, Retaining	66 120954X	Pin, Dowel
27 120470X	Sprocket, 18 Teeth	67 134799	Screw, Self-Tapping, Large 5/16-18 x 2.25
28 110070X	Spacer	68 138244	Lever, Actuating
29 108977X	Gear, Spur, 37 Teeth	69 108996X	Washer, Plain .321 x 1.00 x .055
30 109254X	Gear, Spur, 35 Teeth	70 120956X	Bracket, Anti-Rotation
31 120405X	Gear, Spur, 30 Teeth	71 106596X	Screw, Self-Tapping, Large 5/16-18 x 1.44
32 108980X	Gear, Spur, 25 Teeth	72 120951X	Puck, Friction
33 120406X	Gear, Spur, 22 Teeth	73 120416X	Grease
34 134796	Gear, Spur, 19 Teeth		
35 105925X	Washer, Plain .640 x 1.37 x .061		
36 2232J	Washer, Plain .632 x 1.00 x .026		
37 108978X	Spacer .630 x 1.00 x .169		
38 110079X	Assembly, Gear, Combination of 12 Teeth and 35 Teeth		
39 124639X	Shaft, Idler		
40 120472X	Spacer .635 x .875 x .755		

\* Use in combinations to maintain proper clearances

\*\* Order Key No. 15

**NOTE:** All component dimensions given in U.S. inches  
1 inch = 25.4 mm

# REPAIR PARTS

14 HP 42" TRACTOR - - MODEL NUMBER 917.254850

KOHLER ENGINE - MODEL NUMBER CV14S, TYPE NUMBER PS1452

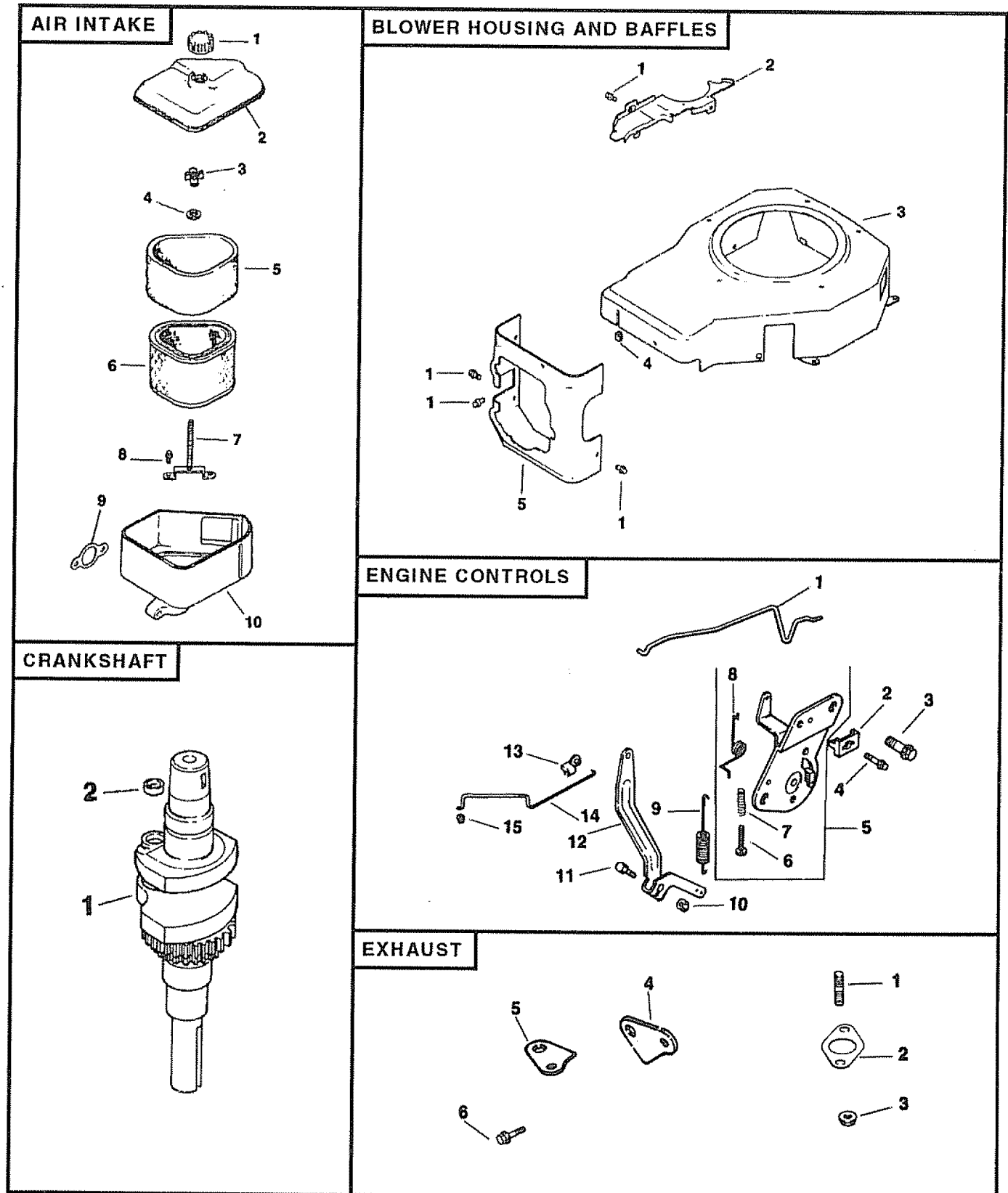



# REPAIR PARTS

## 14 HP 42" TRACTOR - - MODEL NUMBER 917.254850

### KOHLER ENGINE - MODEL NUMBER CV14S, TYPE NUMBER PS1452

#### AIR INTAKE

KEY PART NO. NO.	DESCRIPTION
1 12 341 01	Knob, Air Cleaner Cover
2 12 096 06	Cover, Air Cleaner
3 12 100 01	Wing Nut
4 X-25-63	Washer, Plain 1/4
5 12 083 08	Precleaner Element
6 12 083 05	Element, Air Cleaner
7 12 072 03	Stud, Mounting Plate
8 12 086 01	Screw, Mounting Plate Stud
9 12 041 02	Gasket, Air Cleaner
10 12 094 01	Base, Air Cleaner

#### NOT ILLUSTRATED

-- 12 113 27 Decal, Air Cleaner

#### EXHAUST

KEY PART NO. NO.	DESCRIPTION
1 M-0829033	Stud, Exhaust Manifold M8 x 1.25 x 20 (2)
2 12 041 03	Gasket, Exhaust Manifold
3 M-0841080	Nut, Muffler Mounting M8 x 1.25 (2)
4 12 126 11	Bracket, Muffler
5 12 445 01	Strap, Lifting
6 M-0645025	Screw, Lifting Strap M6 x 1.0 x 25 (2)
-- 12 522 01	Short Block
-- 12 755 01	Gasket Set

#### CRANKSHAFT

KEY PART NO. NO.	DESCRIPTION
1 12 014 02	Crankshaft
2 12 139 01	Plug, Cup

#### BLOWER HOUSING AND BAFFLES

KEY PART NO. NO.	DESCRIPTION
1 SM-0545010	Screw, Mounting M5 x 0.8 x 10 (12)
2 12 146 07	Plate, Blower Housing
3 12 027 14	Housing, Blower
4 12 313 03	Grommet, Blower Housing
5 12 063 08	Baffle, Cylinder Head

#### NOT ILLUSTRATED

-- 12 113 28 Decal, Horsepower

#### ENGINE CONTROLS

KEY PART NO. NO.	DESCRIPTION
1 12 079 07	Linkage, Choke
2 12 237 01	Clamp, Cable
3 SM-0645016	Screw, Hex Head M6 x 1.0 x 16 (2)
4 SM-0545016	Screw, Cable Clamp
5 12 536 01	Control, Speed Assembly (Includes Key Numbers 6 through 8)
6 SM-0443025	Screw
7 12 089 11	Spring, Choke Adjust
8 12 089 04	Spring, Choke Return
9 12 089 19	Spring, Governor
10 SM-0641060	Nut, Governor Arm M6 x 1.0
11 SM-0642025	Screw, Governor Arm M6 x 1.0 x 25
12 12 090 05	Lever, Governor
13 25 158 11	Bushing
14 12 079 01	Linkage, Throttle
15 25 158 08	Bushing

**NOTE:** All component dimensions given in U.S. inches  
1 inch = 25.4 mm

RPM Settings: High speed 3200-3400  
Low speed 1500-2000

# REPAIR PARTS

14 HP 42" TRACTOR - - MODEL NUMBER 917.254850

KOHLER ENGINE - MODEL NUMBER CV14S, TYPE NUMBER PS1452

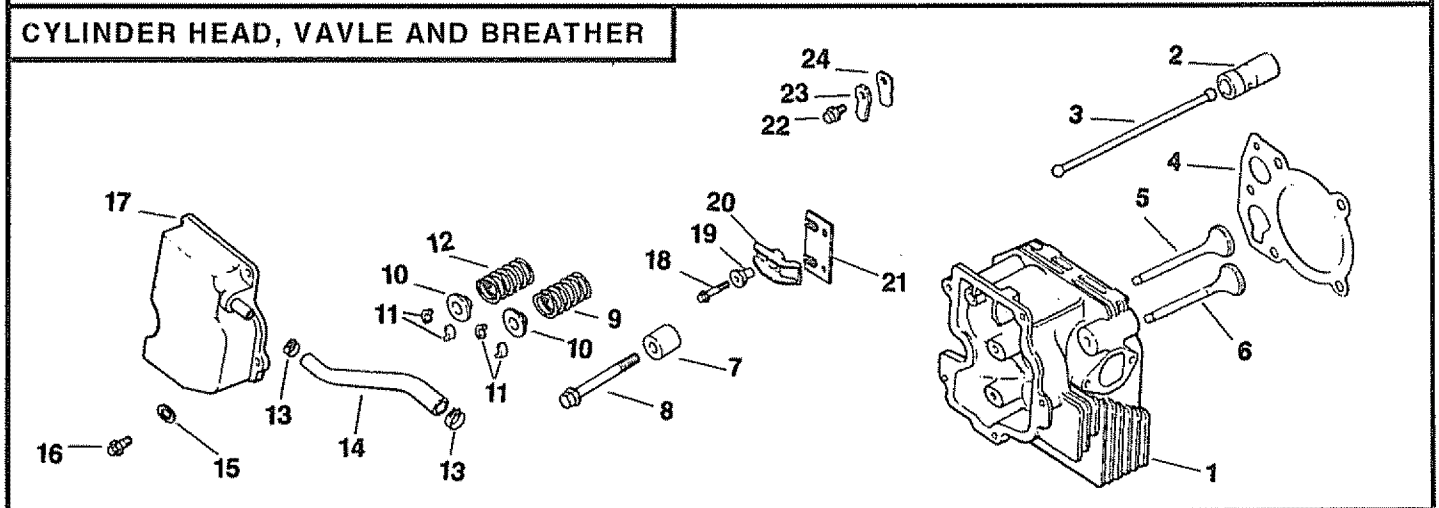
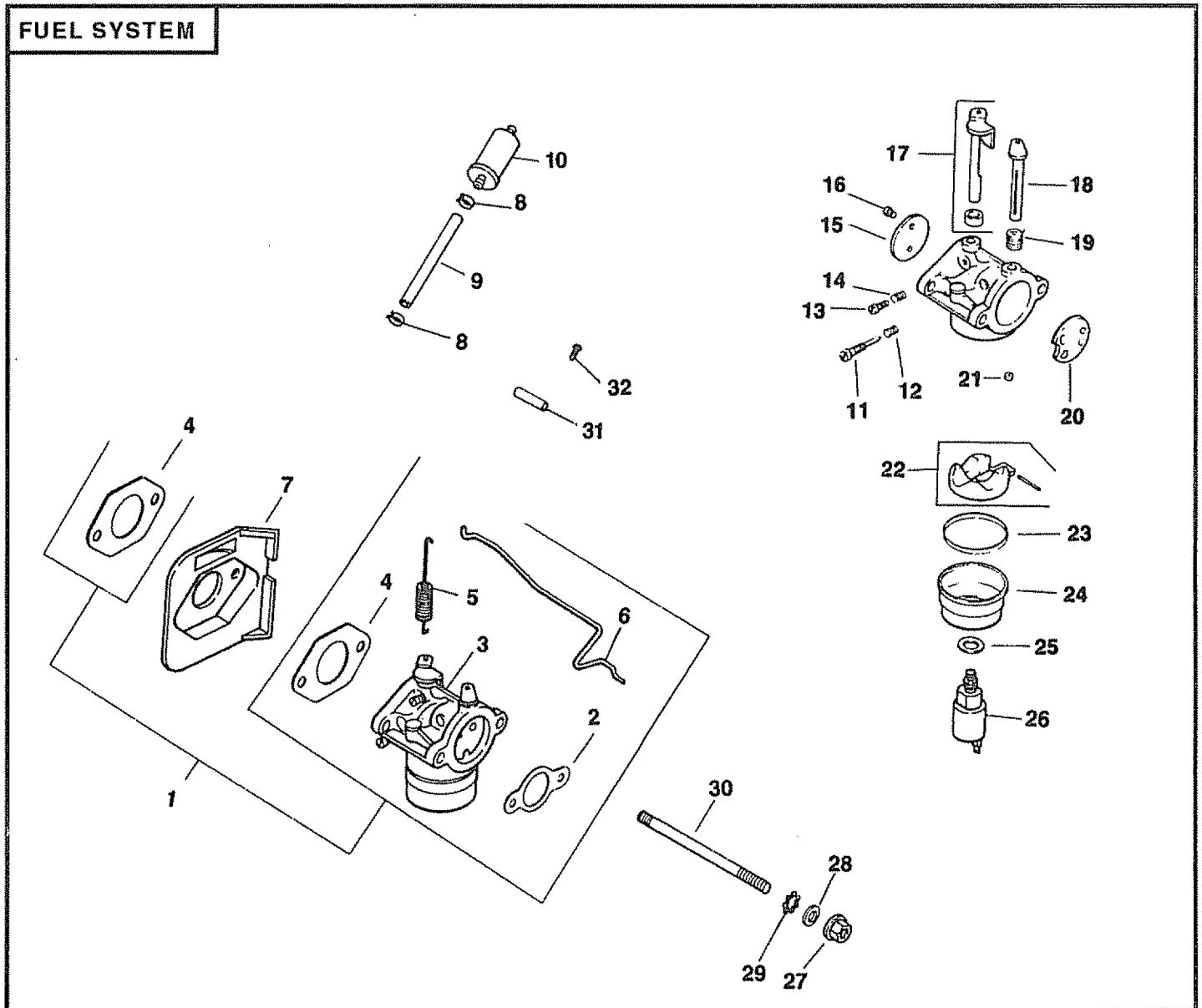

# REPAIR PARTS

## 14 HP 42" TRACTOR - - MODEL NUMBER 917.254850

### KOHLER ENGINE - MODEL NUMBER CV14S, TYPE NUMBER PS1452

#### FUEL SYSTEM

KEY PART NO. NO.	DESCRIPTION
1 12 853 26	Kit, Carburetor (Includes Key Numbers 2 thru 6)
2 12 041 02	Gasket, Air Cleaner
3 12 053 32	Carburetor Assembly (For Information Only - Not Available Separately) (Includes Key Numbers 11 thru 26)
4 12 041 01	Gasket, Carburetor (2)
5 12 089 04	Spring, Choke Return
6 12 079 07	Linkage, Choke
7 12 265 01	Deflector, Heat
8 X-426-9	Clamp, Hose (2)
9 25 353 02	Fuel Line, 3"
10 25 050 02	Filter, Fuel
11 12 368 01	Needle, Idle, Fuel Adjust
12 12 089 09	Spring, Idle Fuel
13 12 086 04	Screw, Idle Speed Adjust
14 12 089 09	Spring, Idle Speed
15 12 146 03	Plate, Throttle
16 25 086 27	Screw, Throttle Plate (2)
17 12 144 09	Shaft, Throttle with Lever and Seal
18 12 144 08	Shaft, Choke
19 12 089 10	Spring, Choke Return
20 12 146 02	Plate, Choke
21 12 337 01	Jet, Main
22 12 757 02	Kit, Float
23 12 041 05	Gasket, Bowl
24 12 104 01	Bowl, Fuel
25 12 041 06	Gasket, Bowl Retainer Screw
26 12 757 09	Kit, Solenoid Assembly
27 SM-0641060	Nut, Carburetor M6 x 1.0 (2)
28 X-25-63	Washer, Plain 1/4
29 X-22-11	Washer, Internal Tooth 1/4
30 M-0629122	Stud, Carburetor M6 x 1.0 x 110 (2)
31 12 431 01	Sleeve, Insulating
32 12 086 07	Screw, Ground Wire

#### NOT ILLUSTRATED

-- 12 757 03	Kit, Carburetor Repair
-- 12 755 09	Kit, High Altitude Jet
-- 12 518 05	Lead, Solenoid, Black, 5", 14 Gauge, Uninsulated Push-On Tabs
-- 41 518 34	Lead, Ground, Green, 5", 18 Gauge Insulated Grip Barrel Eyelets

#### CYLINDER HEAD, VALVE AND BREATHER

KEY PART NO. NO.	DESCRIPTION
1 12 318 02	Head, Cylinder
2 12 351 01	Lifter, Valve (2)
3 12 411 01	Rod, Push (2)
4 12 041 08	Gasket, Cylinder Head
5 12 017 01	Valve, Intake, Standard Size
12 017 02	Valve, Intake, .25" Oversize
6 12 016 01	Valve, Exhaust, Standard Size
12 016 02	Valve, Exhaust, .25" Oversize
7 12 112 13	Spacer, Head Bolt Exhaust Port
8 12 086 15	Screw, Cylinder Head M10 x 1.5 x 80 (5)
9 12 089 15	Spring, Exhaust Valve
10 12 173 01	Cap, Valve Spring (2)
11 12 755 03	Kit, Retainer (2)
12 12 089 01	Spring, Intake Valve
13 X-426-9	Clamp, Hose (2)
14 12 326 03	Hose, Breather
15 12 468 05	Washer, Flat
16 SM-0645020	Screw, Valve Cover M6 x 1.0 x 20 (5)
17 12 096 07	Cover, Valve with Nipple
18 M-0640034	Screw, Rocker Arm M6 x 1 x 34 (2)
19 24 194 01	Ball, Rocker Pivot (2)
20 24 186 01	Arm, Rocker (2)
21 12 146 13	Plate, Guide
22 SM-0545010	Screw, Breather Reed Retainer M5 x 0.8 x 10
23 12 018 01	Retainer, Breather Reed
24 12 402 01	Reed, Breather

**NOTE:** All component dimensions given in U.S. inches  
1 inch = 25.4 mm

# REPAIR PARTS

14 HP 42" TRACTOR - - MODEL NUMBER 917.254850

KOHLER ENGINE - MODEL NUMBER CV14S, TYPE NUMBER PS1452

## IGNITION / ELECTRICAL

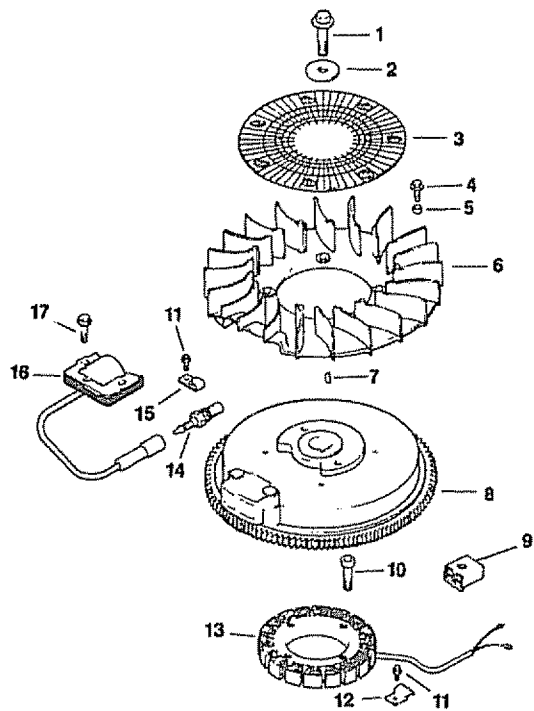

## OIL PAN / LUBRICATION

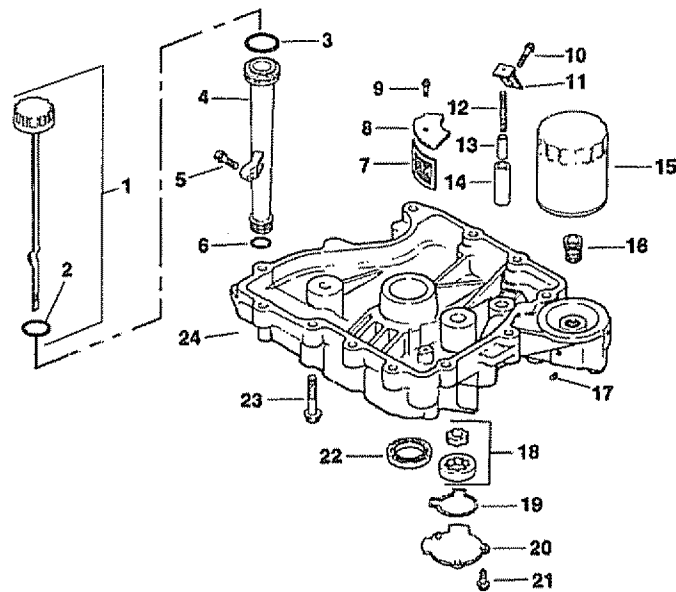

## CRANKCASE

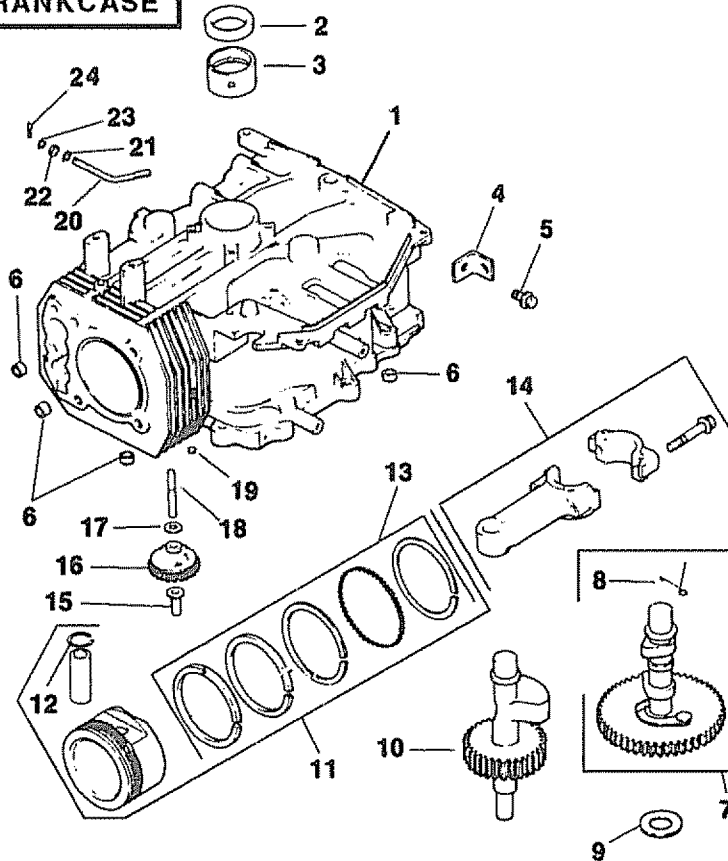

## STARTING SYSTEM

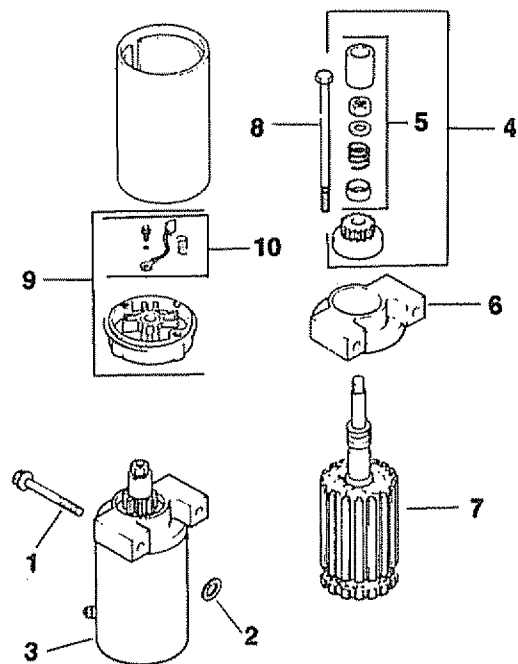

# REPAIR PARTS

## 14 HP 42" TRACTOR - - MODEL NUMBER 917.254850

### KOHLER ENGINE - MODEL NUMBER CV14S, TYPE NUMBER PS1452

#### IGNITION / ELECTRICAL

KEY PART NO. NO.	DESCRIPTION
1 12 086 14	Screw, Flywheel M10 x 1.5 x 45.8
2 12 468 03	Washer, Flywheel
3 12 162 01	Screen, Grass
4 M-0639016	Screw, Fan M6 x 1 x 13 (4)
5 12 112 01	Spacer, Fan (4)
6 12 157 02	Fan
7 X-42-15	Key
8 12 025 25	Flywheel Assembly
9 41 155 02	Connector
10 M-0548025	Screw, Stator Mounting M5 x 0.8 x 25 (4)
11 SM-0545010	Screw, Stator Harness Clip M5 x 0.8 x 10 (2)
12 12 154 02	Clip, Stator Harness
13 12 085 03	Stator Assembly, 15 Amp
14 12 132 02	Spark Plug
15 X-728-1	Clip, Cable
16 12 584 01	Module, Ignition
17 SM-0545020	Screw, Ignition Module M5 x 0.8 x 20 (2)

#### NOT ILLUSTRATED

-- 12 518 01	Lead, White, Ground To Kill (19", 18 Gauge, Fully Insulated Push-on Tab and Uninsulated Push-on Tab Terminals)
-- 55 755 01	Kit, Diode

#### OIL PAN / LUBRICATION

KEY PART NO. NO.	DESCRIPTION
1 12 038 01	Dipstick Assembly (Includes #2)
2 12 153 03	O-Ring, Dipstick
3 12 153 02	O-Ring, Upper Oil Fill Tube
4 12 123 04	Tube, Oil Fill
5 SM-0545020	Screw, Oil Fill Tube M5 x 0.8 x 20
6 12 153 01	O-Ring, Lower Oil Fill Tube
7 12 162 02	Screen, Oil Pickup
8 12 096 03	Cover, Oil Pickup Screen
9 SM-0545016	Screw, Screen Cover
10 M-1051025	Screw, Oil Pump Relief Valve Bracket M10 x 1.5 x 25
11 12 126 02	Bracket, Oil Pump Relief Valve
12 12 089 03	Spring, Oil Pump Relief Valve
13 12 462 01	Piston, Oil Pump Relief Valve
14 12 208 01	Body, Oil Pump Relief Valve
15 12 050 01	Filter, Oil
16 12 136 01	Adapter, Oil Filter
17 X-75-10	Plug, Square Head, Solid 3/8 NPTF
18 12 393 01	Oil Pump Assembly
19 12 032 04	O-Ring, Oil Pump Cover
20 12 096 02	Cover, Oil Pump
21 SM-0545016	Screw, Oil Pump Cover M5 x 0.8 x 16 (3)
22 12 032 03	Seal, Oil (P.T.O. End)
23 SM-0839045	Screw, Oil Pan M8 x 1.25 x 45 (12)
24 12 199 33	Pan, Oil

#### CRANKCASE

KEY PART NO. NO.	DESCRIPTION
1 ---	Block, Cylinder (Use Short Block, Part Number 12 522 01)
2 12 032 03	Seal, Crankshaft
3 12 030 01	Bearing, Crankshaft, Standard (Flywheel End)
	12 030 02 Bearing, Crankshaft .25" oversize
	12 030 03 Bearing, Crankshaft .50" oversize
4 12 445 02	Strap, Lifting
5 M-0839025	Screw, Lifting Strap M8 x 1.25 x 22
6 12 380 03	Dowel, Locating (4)
7 12 010 04	Camshaft Assembly (Includes #8)
8 12 089 18	Spring, Actuating
9 12 422 08	Shim, Camshaft
	12 422 09 Shim, Camshaft (as required)
	12 422 10 Shim, Camshaft (as required)
	12 422 11 Shim, Camshaft (as required)
	12 422 12 Shim, Camshaft (as required)
	12 422 13 Shim, Camshaft (as required)
	12 422 07 Shim, Camshaft (as required)
10 12 144 04	Shaft, Balance
11 12 874 01	Piston w/Ring Set, Standard
	12 874 02 Piston w/Ring Set .25" oversize
	12 874 03 Piston w/Ring Set .50" oversize
12 12 018 02	Retainer, Piston Pin (2)
13 12 108 01	Ring Set, Standard
	12 108 02 Ring Set .25" oversize
	12 108 03 Ring Set .50" oversize
14 12 067 01	Connecting Rod, Standard
	12 067 02 Connecting Rod .25" oversize
15 12 380 01	Pin, Governor Regulating
16 12 043 05	Gear, Governor Assembly
17 SM-0631005	Washer, Governor Gear Thrust
18 12 144 02	Shaft, Governor Gear
19 52 139 09	Plug, Cup
20 12 144 01	Shaft, Governor Cross
21 SM-0631015	Washer, Governor Shaft
22 12 032 01	Seal, Governor Cross Shaft
23 X-25-102	Washer, Plain 1/4
24 12 380 04	Pin, Governor Hitch

#### STARTING SYSTEM

KEY PART NO. NO.	DESCRIPTION
1 M-0839070	Screw, Bendix Starter M8 x 1.25 x 70 (2)
2 12 468 01	Washer (2)
3 12 098 05	Starter Bendix (Includes #4-10)
4 12 755 12	Kit, Drive (Includes Key Number 5)
5 12 755 06	Kit, Drive Parts
6 12 227 01	Cap, Drive End
7 12 170 02	Armature
8 12 086 02	Screw, Hex Flange
9 12 243 01	Cap, Commutator End (Includes Key Number 10)
10 52 755 15	Kit, Brush

#### NOT ILLUSTRATED

-- 52 357 01 Lubricant, Starter

**NOTE:** All component dimensions given in U.S. inches  
1 inch = 25.4 mm

---

# SERVICE NOTES

---

# SUGGESTED GUIDE FOR SIGHTING SLOPES FOR SAFE OPERATION

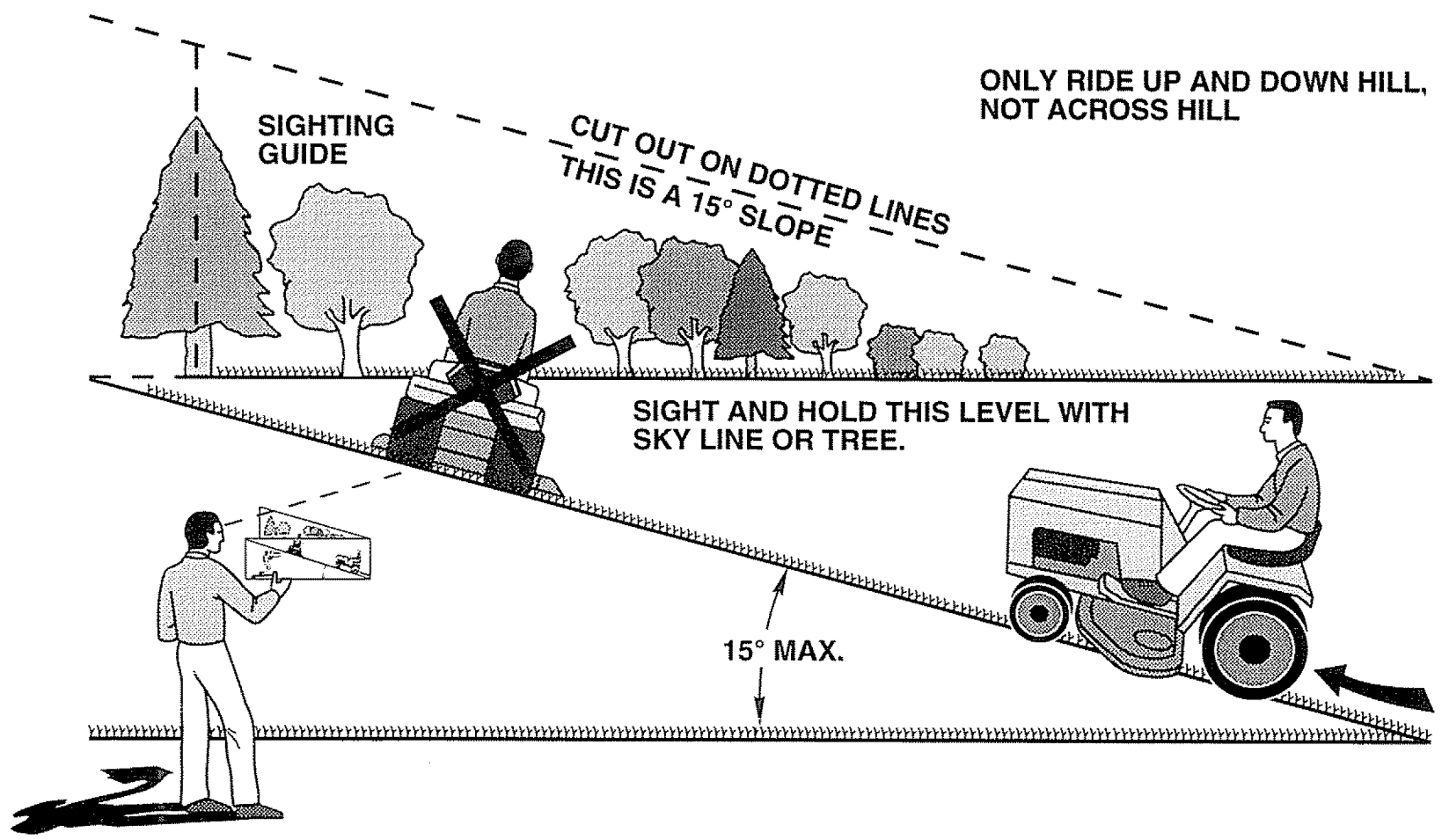

 Operate your Tractor up and down the face of slopes (not greater than 15°), never across the face. Make turns gradually to prevent tipping or loss of control. Exercise extreme caution when changing direction on slopes.

**SEARS**

**OWNER'S  
MANUAL**

**MODEL NO.  
917.254850**

**HOW TO ORDER  
REPAIR PARTS**

**CRAFTSMAN®**

**14.0 HP  
ELECTRIC START  
3 in One Convertible  
42" MOWER  
6 SPEED TRANSAXLE  
LAWN TRACTOR**

Each tractor has its own model number. Each engine has its own model number.

The model number for your tractor will be found on the model plate located under the seat.

The model number for your engine will be found on the blower housing of the engine.

All parts listed herein may be ordered from any Sears, Roebuck and Co. Service Center/Department and most Retail Stores.

**WHEN ORDERING REPAIR PARTS, ALWAYS GIVE THE  
FOLLOWING INFORMATION:**

- **PRODUCT - LAWN TRACTOR**
- **MODEL NUMBER - 917.254850**
- **ENGINE MODEL NO. - CV14S, TYPE NO. 1452**
- **PART NUMBER**
- **PART DESCRIPTION**

Your Sears merchandise has added value when you consider Sears has service units nationwide staffed with Sears trained technicians... professional technicians specifically trained to insure that we meet our pledge to you, we service what we sell.