

*Cub Cadet*®

**Power Equipment**

# Owner's Manual

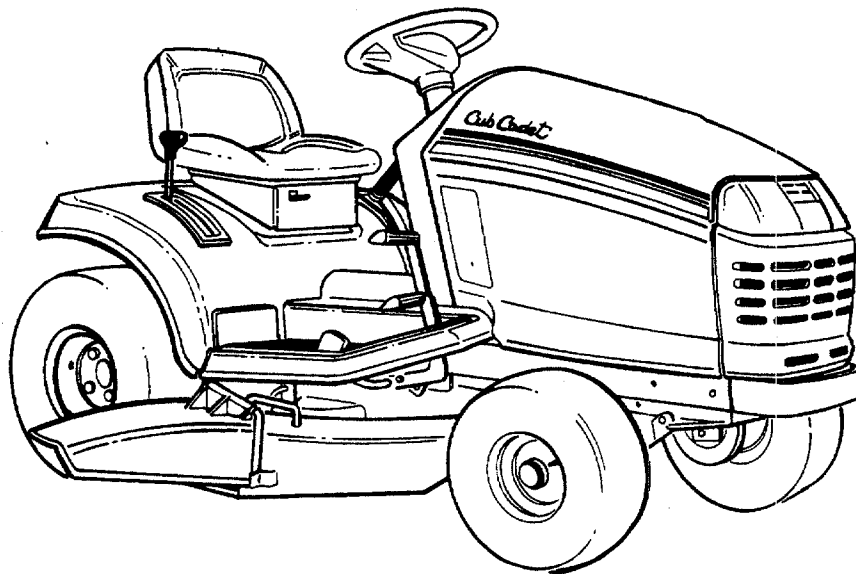

*Series* **2000**  
**TRACTOR**  
**Model Numbers**  
**2130**  
**2135**

**Important:**  
**Read Safety Rules and Instructions Carefully**

Thank you for purchasing an American-built product

**CUB CADET CORPORATION • P.O. BOX 368023 • CLEVELAND, OHIO 44136-9723**

MADE IN U.S.A.

FORM NO. 772-9037A

# **LIMITED WARRANTY**

**TWO-YEAR RESIDENTIAL  
ONE-YEAR COMMERCIAL**

Proper maintenance of your Cub Cadet equipment is the owner's responsibility. Follow the instructions in your owner's manual for correct lubricants and maintenance schedule. Your Cub Cadet dealer carries a complete line of quality lubricants and filters for your equipment's engine, transmission, chassis and attachments.

## **RIDING MOWERS, LAWN TRACTORS, GARDEN TRACTORS, CUB CADET ATTACHMENTS AND HOME MAINTENANCE PRODUCTS**

This limited warranty for residential users, covers any defect in materials or workmanship in your Cub Cadet equipment for two years from the date of purchase for the first user purchaser.

We will replace or repair any part or parts without charge through your authorized Cub Cadet dealer.

Batteries have a one-year prorated limited warranty with 100% replacement during the first three months.

V-belts for either the traction drive or any attachments are covered for one year only.

Cub Cadet equipment used commercially is warranted for one year only.

(Commercial use is defined as either having hired operators or used for income producing purpose.)

## **ITEMS NOT COVERED**

The warranty does not cover routine maintenance items such as lubricants, filters (oil, fuel, air and hydraulic), cleaning, tune-ups, brake and/or clutch inspection, adjustments made as part of normal maintenance, blade sharpening, set-up, abuse, accidents and normal wear. It does not cover incidental costs such as transporting your equipment to and from the dealer, telephone charges or renting a product temporarily to replace a warranted product.

There is no other express warranty.

## **HOW TO OBTAIN SERVICE**

Contact your authorized Cub Cadet servicing dealer who sold you your Cub Cadet equipment. If this dealer is not available, see the Consumer Yellow Pages under "lawn mowers" for the name of a dealer near you.

If you need further assistance in finding an authorized Cub Cadet servicing dealer, contact:

**Cub Cadet Corporation  
Post Office Box 368023  
Cleveland, Ohio 44136**

## **HOW DOES STATE LAW APPLY?**

This limited warranty gives you specific legal rights, and you may also have other rights which vary from state to state.

# CONTENTS

Section	Page	Section	Page
Warranty .....	2	VII Mowing .....	47
Safe Operation Practices .....	3	Optional Equipment and Accessories .....	48
Product Graphics .....	7	Maintenance Chart .....	49
To The Owner .....	8	Trouble Shooting .....	50
Serial No. Location .....	8	Lubrication Table .....	52
Controls and Indicators .....	9	Lubrication Guide .....	53
II Operation .....	14	Specifications .....	56
III Adjustments .....	19	Slope Gauge .....	57
IV Maintenance .....	25	Maintenance Parts Chart .....	59
V Mower Deck .....	34		
VI Off-Season Storage .....	46		

## ATTACHING THE CHUTE DEFLECTOR



### WARNING

Do not operate your unit unless the chute deflector has been properly installed.

Remove truss machine screws, bell washers and hex nuts which are attached to the deck next to the chute opening.

Proper placement of the chute deflector will cover up the warning label on the chute opening. Place the deflector in position as shown. Secure with hardware just removed.

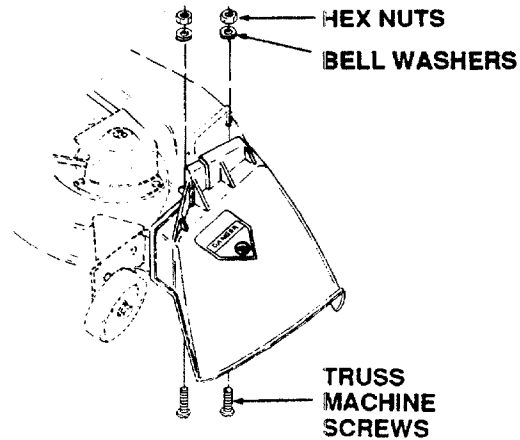

### WARNING

This unit is equipped with an internal combustion engine and should not be used on or near any unimproved forest-covered, brush-covered or grass-covered land unless the engine's exhaust system is equipped with a spark arrester meeting applicable local or state laws (if any). If a spark arrester is used, it should be maintained in effective working order by the operator.

In the State of California the above is required by law (Section 4442 of the California Public Resources Code). Other states may have similar laws. Federal laws apply on federal lands. A spark arrester muffler is available at your nearest engine authorized service center.

# IMPORTANT

## SAFE OPERATION PRACTICES



THIS SYMBOL POINTS OUT IMPORTANT SAFETY INSTRUCTIONS WHICH, IF NOT FOLLOWED, COULD ENDANGER THE PERSONAL SAFETY AND/OR PROPERTY OF YOURSELF AND OTHERS. READ AND FOLLOW ALL INSTRUCTIONS IN THIS MANUAL BEFORE ATTEMPTING TO OPERATE YOUR UNIT. WHEN YOU SEE THIS SYMBOL -  **HEED ITS WARNING.**



**DANGER:**

Your lawn mower was built to be operated according to the rules for safe operation in this manual. As with any type of power equipment, carelessness or error on the part of the operator can result in injury. This lawn mower is capable of amputating hands and feet and throwing objects. Failure to observe the following safety instructions could result in serious injury or death.



**I. GENERAL OPERATION**

1. Read, understand and follow all instructions in the manual and on the machine before starting. Keep this manual in a safe place for future and regular reference and for ordering replacement parts.
2. Only allow responsible individuals familiar with the instructions to operate the machine. Know controls and how to stop the machine quickly.
3. Do not put hands or feet under cutting deck or near rotating parts.
4. Clear the area of objects such as rocks, toys, wire, etc. which could be picked up and thrown by the blade. A small object may have been overlooked and could be accidentally thrown by the mower in any direction and cause injury to you or a bystander. To help avoid a thrown objects injury, keep children, animals, bystanders and helpers at least 75 feet from the mower while it is in operation. Always wear safety glasses with side shields or safety goggles during operation or while performing an adjustment or repair, to protect eyes from foreign objects. Stop the blade(s) when crossing gravel drives, walks or roads.
5. Be sure the area is clear of other people before mowing. Stop machine if anyone enters the area.
6. Never carry passengers.
7. Disengage blade(s) before shifting into reverse and backing up. Always look down and behind before and while backing.
8. Be aware of the mower and attachment discharge direction and do not point it at anyone. Do not operate the mower without either the entire grass catcher or the chute guard in place.
9. Slow down before turning. Operate the machine smoothly. Avoid erratic operation and excessive speed.
10. Never leave a running machine unattended. Always turn off blade(s), place transmission in neutral, set park brake, stop engine and remove key before dismounting.
11. Turn off blade(s) when not mowing.
12. Stop engine and wait until blade(s) comes to a complete stop before (a) removing grass catcher or unclogging chute, or (b) making any repairs, adjusting or removing any grass or debris.
13. Mow only in daylight or good artificial light.
14. Do not operate the machine while under the influence of alcohol or drugs.
15. Watch for traffic when operating near or crossing roadways.
16. Use extra care when loading or unloading the machine into a trailer or truck. This unit should not be driven up or down a ramp onto a trailer or truck under power, because the unit could tip over causing serious personal injury. The unit must be pushed manually on a ramp to load or unload properly.
17. Never make a cutting height adjustment while the engine is running if operator must dismount to do so.
18. Wear sturdy, rough-soled work shoes and close-fitting slacks and shirts. Do not wear loose fitting clothes or jewelry. They can be caught in moving parts. Never operate a unit in bare feet, sandals or sneakers.
19. Check overhead clearance carefully before driving under power lines, wires, bridges or low hanging tree branches, before entering or leaving buildings, or in any other situation where the operator may be struck or pulled from the unit, which could result in serious injury.
20. Disengage all attachment clutches, thoroughly depress the brake pedal and shift into neutral before attempting to start engine.
21. Your mower is designed to cut normal residential grass of a height no more than 10". Do not attempt to mow through unusually tall, dry grass (e.g. pasture) or piles of dry leaves. Debris may build up on the mower deck or contact the engine exhaust presenting a potential fire hazard.



**II. SLOPE OPERATION**

Slopes are a major factor related to loss of control and tip-over accidents which can result in severe injury or death. **All** slopes require extra caution. If you cannot back up the slope or if you feel uneasy on it, do not mow it.

For your safety, use the slope gauge included as part of this manual to measure slopes before operating the unit on a sloped or hilly area. If the slope is greater than 15° as shown on the slope gauge, do not operate this unit on that area or serious injury could result.

## DO:

Go up and down slopes, not across.

Avoid obstacles such as rocks, limbs, etc.

Watch for holes, ruts or bumps. Uneven terrain could overturn the machine. **Tall grass can hide obstacles.**

Go slow speed. Choose a low enough gear so that you will not have to stop or shift while on the slope. Always keep machine in gear when going down slopes to take advantage of engine braking action.

Follow the manufacturer's recommendations for wheel weights or counterweights to improve stability.

Use extra care with grass catchers or other attachments. These can change the stability of the machine.

Stop all movement on the slopes **slow and gradual**. Do not make sudden changes in speed or direction. Sudden disengagement or braking could cause the front of the machine to lift and rapidly flip over backwards which could cause serious injury.

Avoid starting or stopping on a slope. If tires lose traction, disengage the blade(s) and proceed slowly **up** the slope.

## DO NOT:

Do not turn on slopes unless necessary; then, turn slowly and gradually downhill, if possible.

Do not mow near drop-offs, ditches or embankments. The mower could suddenly turn over if a wheel is over the edge of a cliff or ditch, or if an edge caves in.

Do not mow on wet grass. Reduced traction could cause sliding.

Do not try to stabilize the machine by putting your foot on the ground.

Do not use grass catcher on steep slopes.

## III. CHILDREN

Accidental accidents can occur if the operator is not alert to the presence of children. Children are often attracted to the machine and the mowing activity. Never assume that children will remain where you last saw them.

Keep children out of the mowing area and in the watchful care of an adult other than the operator.

Be alert and turn machine off if children enter the mowing area.

Before and when backing, look behind and **down** for small children.



4. Never carry children. They may fall off and be seriously injured or interfere with safe machine operation.
5. Never allow children under 14 years old to operate the machine. Children 14 years and over should only operate machine under close parental supervision and proper instruction.
6. Use extra care when approaching blind corners, shrubs, trees or other objects that may obscure your vision of a child or other hazard.
7. Remove key when machine is unattended to prevent unauthorized operation.



## IV. SERVICE

1. Use extreme care in handling gasoline and other fuels. They are extremely flammable and the vapors are explosive.
  - A. Use only an approved container.
  - B. Never remove fuel cap or add fuel with the engine running. Allow engine to cool at least two minutes before refueling.
  - C. Replace fuel cap securely and wipe off any spilled fuel before starting the engine as it may cause a fire or explosion.
  - D. Extinguish all cigarettes, cigars, pipes and other sources of ignition.
  - E. Never refuel the machine indoors because fuel vapors will accumulate in the area.
  - F. Never store the fuel container or machine inside where there is an open flame or spark, such as a gas hot water heater, space heater or furnace.
2. Never run a machine inside a closed area.
3. To reduce fire hazard, keep the machine free of grass, leaves or other debris build-up. Clean up oil or fuel spillage. Allow machine to cool at least 5 minutes before storing.
4. Before cleaning, repairing or inspecting, make certain the blade and all moving parts have stopped. Disconnect the spark plug wire, and keep the wire away from the spark plug to prevent accidental starting.
5. Check the blade and engine mounting bolts at frequent intervals for proper tightness. Also visually inspect blade for damage (e.g., excessive wear, bent, cracked). Replace with blade which meets original equipment specifications.
6. Keep all nuts, bolts and screws tight to be sure the equipment is in safe working condition.

7. Never tamper with safety devices. Check their proper operation regularly. Use all guards as instructed in this manual.
8. After striking a foreign object, stop the engine, remove the wire from the spark plug and thoroughly inspect the mower for any damage. Repair the damage before restarting and operating the mower.
9. Grass catcher components are subject to wear, damage and deteriorate, which could expose moving parts or allow objects to be thrown. For your safety protection, frequently check components and replace with manufacturer's recommended parts when necessary.
10. Mower blades are sharp and can cut. Wrap the blade(s) or wear gloves and use extra caution when servicing blade(s).
11. Check brake operation frequently. Adjust and service as required.
12. Muffler, engine and belt guards become hot during operation and can cause a burn. Allow to cool down before touching.
13. Do not change the engine governor settings or overspeed the engine. Excessive engine speeds are dangerous.
14. Observe proper disposal laws and regulations. Improper disposal of fluids and materials can harm the environment and the ecology.
  - A. Prior to disposal, determine the proper method to dispose of waste from your local Environmental Protection Agency. Recycling centers are established to properly dispose of materials in an environmentally safe fashion.
  - B. Use proper containers when draining fluids. Do not use food or beverage containers that may mislead someone into drinking from them. Properly dispose of the containers immediately following the draining of fluids.
  - C. DO NOT pour oil or other fluids into the ground, down a drain or into a stream, pond, lake or other body of water. Observe Environmental Protection Agency regulations when disposing of oil, fuel, coolant, brake fluid, filters, batteries, tires and other harmful waste.

 <p><b>OWNER'S MANUAL</b></p>	 <p><b>SAFETY LABEL</b></p>	 <p><b>WARNING – YOUR RESPONSIBILITY</b></p> <p>Restrict the use of this power machine to persons who read, understand and follow the warnings and instructions in this manual and on the machine.</p>
--	--	--

## PRODUCT GRAPHICS

Keep safety product graphics (decals) clean. Replace any safety graphic that is damaged, destroyed,

missing, painted over or can no longer be read. Replacement safety graphics are available through your dealer.

### STARTING INSTRUCTIONS

1. BE FAMILIAR WITH CONTROLS BEFORE STARTING ENGINE AND OPERATING.
2. SET CHOKE AND MOVE THROTTLE TO MID POSITION.
3. TURN KEY TO THE START POSITION.
4. AFTER ENGINE STARTS OPEN CHOKE.

### STOPPING INSTRUCTIONS

1. DISENGAGE PTO AND SET PARKING BRAKE.
2. MOVE THROTTLE CONTROL TO MID POSITION AND TURN KEY OFF.

## WARNING

- AVOID SERIOUS INJURY OR DEATH.
- READ OPERATORS MANUAL AND ALL WARNING LABELS BEFORE USING MACHINE.
- GO UP AND DOWN SLOPES. NOT ACROSS.
- AVOID SUDDEN TURNS
- DO NOT OPERATE UNIT WHERE IT COULD SLIP OR TIP.
- IF MACHINE STOPS GOING UPHILL. STOP PTO AND BACK DOWN HILL SLOWLY.
- DO NOT MOW WHEN CHILDREN OR OTHERS ARE AROUND
- NEVER CARRY CHILDREN
- LOOK DOWN AND BEHIND BEFORE AND WHILE BACKING.
- KEEP SAFETY DEVICES (GUARDS, SHIELDS, AND SWITCHES) IN PLACE AND WORKING.
- REMOVE OBJECTS THAT COULD BE THROWN BY THE BLADES.
- KNOW LOCATION AND FUNCTION OF ALL CONTROLS.
- BE SURE THE BLADES AND THE ENGINE ARE STOPPED BEFORE PLACING HANDS OR FEET NEAR BLADES.
- BEFORE LEAVING OPERATOR'S POSITION, DISENGAGE PTO, ENGAGE BRAKE LOCK, SHUT OFF ENGINE AND REMOVE KEY.

GENERAL SAFETY INSTRUCTIONS  
WARNING – LOCATED ON RIGHT  
SIDE OF RUNNING BOARD  
(MODEL 2135 SHOWN)



SAFETY GRAPHIC – LOCATED  
ON MOWER DECK



HANDS AND FEET SAFETY  
GRAPHIC – LOCATED ON  
CHUTE DEFLECTOR

 **DANGER**  
ASSEMBLE CHUTE DEFLECTOR  
TO THIS UNIT  
BEFORE OPERATING MACHINE

DEFLECTOR SAFETY GRAPHIC –  
LOCATED ON DECK

# TO THE OWNER

*Cub Cadet* tractors, Models 2130 and 2135, are shipped with 38-inch mower deck. Contained in this manual are operation, lubrication and maintenance instructions for this equipment. The material has been prepared in detail to help you better understand the correct care and efficient operation of your tractor. Before you operate the tractor, study this manual carefully. Additional copies may be ordered from your dealer at a nominal price.

Your local authorized dealer is interested in the performance you receive from your tractor. He has factory-trained servicemen, informed in the latest method of servicing tractors, modern tools and original-equipment service parts which assure proper fit and good performance.



## CAUTION

DO NOT tow your Model 2135 tractor. Towing or pushing for more than a few feet may damage the hydrostatic drive unit.

The *Cub Cadet* 2135 Tractor has a hydrostatic drive unit and will require minimum service if recommended operation and maintenance procedures are followed.

To obtain top performance and assure economical operation the tractor should be inspected, depending on its use, periodically, or at least once a year, by your authorized dealer.

When in need of parts, always specify the model, chassis, and engine serial numbers, including the prefix and suffix letters. Write these serial numbers in the space provided on this page.

Should you have difficulties with the unit, consult your authorized dealer. **UNDER NO CIRCUMSTANCES SHOULD YOU ATTEMPT TO SERVICE THESE UNITS YOURSELF.** Only your dealer is authorized to repair or replace units on this drive under the terms of the warranty. Should you desire additional information not found in this manual, contact your authorized *Cub Cadet* dealer.

## SERIAL NUMBER LOCATION



## NOTE

LEFT and RIGHT indicate the left and right sides of the tractor when facing forward in the driver's seat. Reference to FRONT indicates grille end of the tractor; to REAR the drawbar end.

Chassis serial number plate is on the left hand side of frame under the running board. (Refer to Figure 1.)

### CHASSIS SERIAL NUMBER

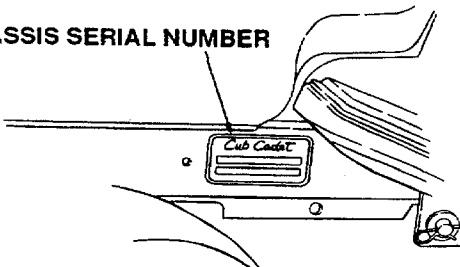

Figure 1

Engine serial number decal is located on the left side of engine blower housing. (Refer to Figure 2.)

### ENGINE SERIAL NUMBER

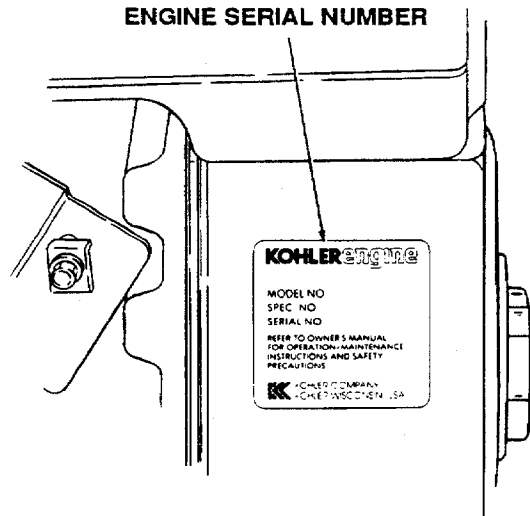

Figure 2

MODEL \_\_\_\_\_

DELIVERY DATE \_\_\_\_\_



## SECTION I. CONTROLS AND INDICATORS

Your *Cub Cadet* Tractor has been safety engineered. Thoroughly acquaint yourself with all the controls and

indicators before attempting to start or operate the tractor.

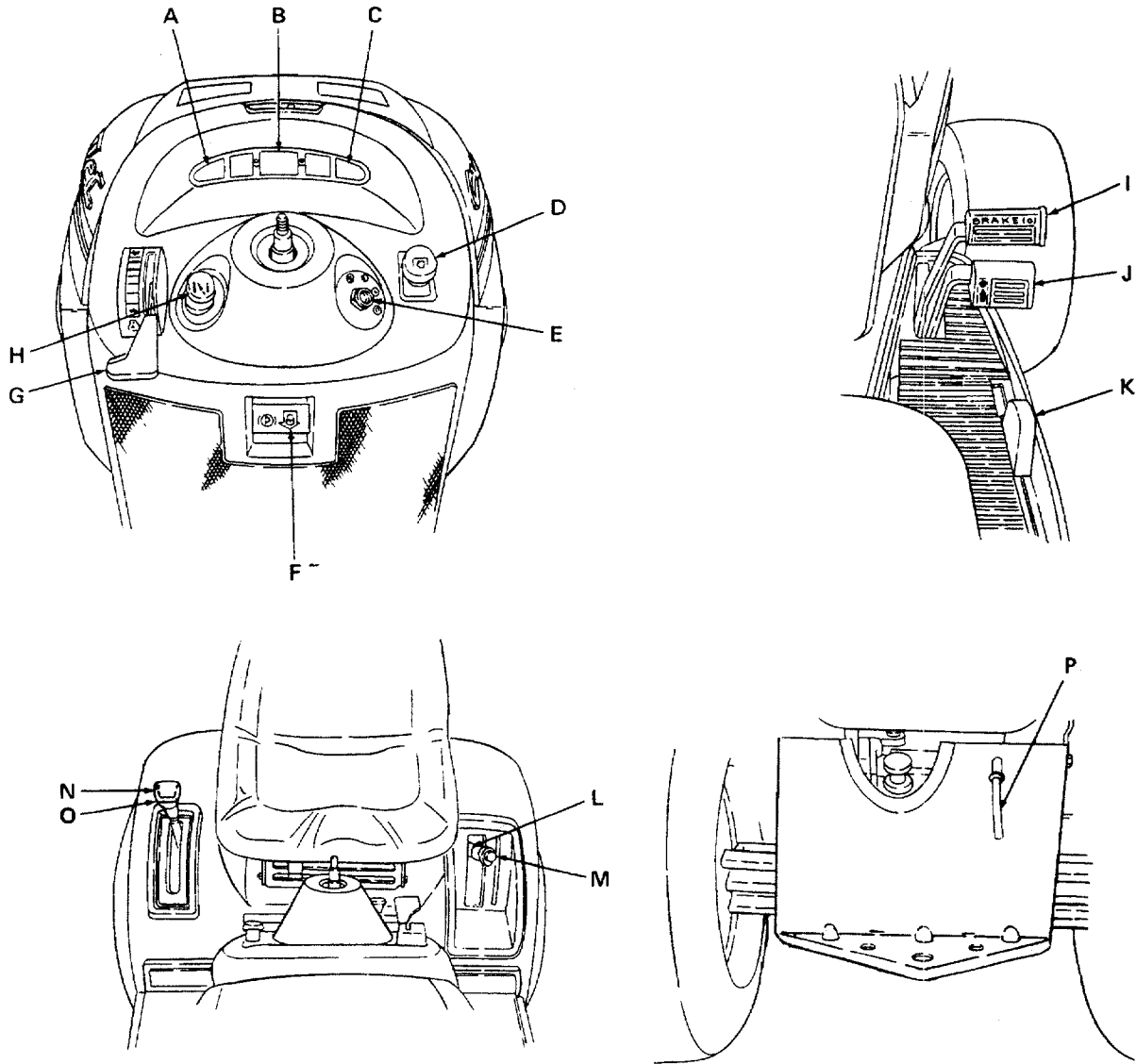

- A. Low Oil Indicator
- B. Hour Meter
- C. Amp Indicator
- D. Power Take-Off (PTO) Control Switch
- E. Ignition/Light Switch
- F. Brake Pedal Lock
- G. Throttle Control Lever
- H. Choke Control
- I. Brake Pedal
- J. Forward Control Pedal

- K. Reverse Control Pedal
- L. Lift Handle
- M. Lift Height Indicator
- N. Speed Control Lever (2130 only)
- O. Cruise Control Lever (2135 only)
- P. Transmission Release Lever (2135 only)
- Q. Seat Adjustment Lever (Not Shown)
- R. Fuse (Not Shown)
- S. Safety Interlock Switches (Not Shown)

Figure 3

### A. LOW OIL INDICATOR

This indicator will illuminate when the oil level is low.



#### CAUTION

When LOW OIL indicator illuminates, stop the tractor and check the oil level. Continuing to operate the tractor could result in severe damage to the engine.

### B. HOUR METER

The hour meter indicates the actual hours of engine operation. This enables the operator to determine when lubrication, change of oil or periodic inspections are necessary. It also provides a means of computing cost of specific jobs. The hour meter operates whenever the engine is running or the ignition key is in the "ON" position.

### C. AMP INDICATOR

This indicator will illuminate when a problem exists with the charging system or the battery. If this indicator illuminates, stop the tractor and contact your *Cub Cadet Dealer*.

### D. POWER TAKE-OFF (PTO) CONTROL SWITCH

The power take-off (PTO) control switch, which is located on the right side of the instrument panel (see Figure 3), operates an electric clutch. This electric clutch controls the engagement ("RUN") or disengagement ("OFF") of the front PTO.

### E. IGNITION/LIGHT SWITCH



#### WARNING

Remove the key from the tractor when the tractor is not in use to prevent accidental starting and battery discharge.

The combination lights and ignition switch is a four-position switch. (See Figure 4.)

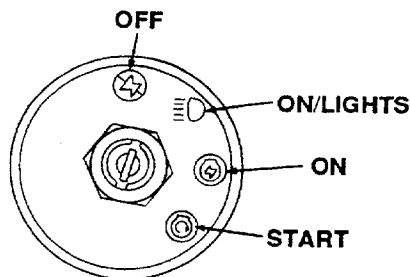

Figure 4

### F. BRAKE PEDAL LOCK



#### WARNING

The hydrostatic transmission will not hold the tractor on a hill. In a short period of time (depending on the steepness of the hill) the oil will drain from the transmission and allow the tractor to roll downhill. To avoid an accident and/or possible injury, engage the brake pedal lock.

Always engage the brake pedal lock when dismantling the tractor. To engage the brake pedal lock depress brake pedal and push down on the brake pedal lock lever. Hold the lever down while releasing the brake pedal. Release the brake pedal lock lever last.

### G. THROTTLE CONTROL LEVER

This lever controls the speed of the engine. When set in a given position, it will maintain a uniform engine speed.



#### NOTE

When using power take-off operated equipment, best performance is achieved with the throttle lever in the "FAST" position.



This symbol shows slow position.

This symbol shows fast position.

### H. CHOKE CONTROL

The choke control is operated manually. Pull knob out to choke engine. Push knob in to open choke. (See Figure 3.)

### I. BRAKE PEDAL

Brake pedal is located in the right front running board above the forward control pedal. Press down to stop tractor or disengage cruise control. Brake pedal must be pressed all the way down to activate the safety starting switch.

### J. FORWARD CONTROL PEDAL

Forward control pedal is located in the right front running board below the brake pedal. Slowly press down on pedal to move forward.

## K. REVERSE CONTROL PEDAL



### WARNING

Check behind tractor to be sure area is clear of people, pets or obstacles. Use a slower speed when traveling in reverse to maintain control of tractor.

Reverse control pedal is located in the right front running board below the brake and forward control pedals. Press down on pedal to move in reverse.

## L. LIFT HANDLE

The lift handle is located in the left fender and is used to raise and lower equipment used with the tractor. The equipment can be set in six positions by depressing the button on the top of the lever and releasing it when the desired position is reached. (Refer to Figure 3.) Push or pull slightly on lever before depressing button. There is a lift assist spring which reduces the effort needed to lift attachments. To adjust tension refer to **ADJUSTMENTS** in Section III.

## M. LIFT HEIGHT INDICATOR

The lift height indicator is located in the left fender and indicates the height of deck attachment when installed. (See Figure 3.)

## N. SPEED CONTROL LEVER (2130 only)

The speed control lever is located in the right fender and is used to select any speed in the forward and reverse directions.

Moving the speed control lever forward provides increased forward and reverse speeds. (See Figure 3.)

## O. CRUISE CONTROL LEVER (2135 only)

The cruise control lever is located in the right fender and is used to select and hold any speed from a standstill (with lever in full rearward position) to six miles per hour in the forward direction.

Moving the lever forward provides increased forward speeds without having to depress the forward control pedal.

## P. TRANSMISSION RELEASE LEVER (2135 only)

The transmission release lever is located in rear of tractor in drawbar and disconnects the transmission from the pump so the unit can be pushed a short distance by hand without running. (See Figure 3.)

To disengage transmission pull back on the lever, lift up into slot and release. To reengage transmission pull back on the lever, drop out of slot and release.

## Q. SEAT ADJUSTMENT LEVER

The seat adjustment lever is used to move the seat forward or rearward into one of five positions. (See Figure 5.) Refer to **ADJUSTING THE SEAT** in Section III.

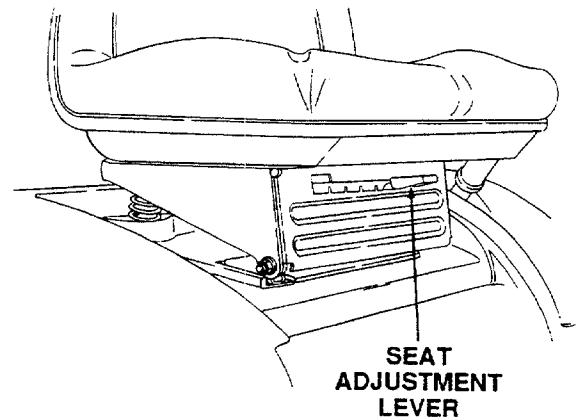

Figure 5

## R. FUSES

The fuses will be located in one of two areas. One area is under the hood on the right side of the engine compartment mounted on the bulkhead and pedestal. (Refer to Figure 6.) The second area is under the hood between the indicator lamps and hour meter. Fuses are installed to protect the tractor's electrical circuitry and components from damage caused by excessive amperage overload.

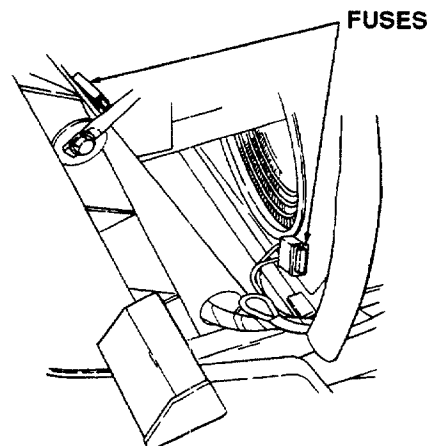

Figure 6

### S. SAFETY INTERLOCK SWITCHES

This tractor is equipped with a safety interlock system for the protection of the operator. If the interlock system should ever malfunction, do not operate the tractor. Contact your authorized *Cub Cadet* Dealer. The safety interlock system prevents the engine from cranking or starting unless the brake pedal is fully depressed, and the PTO switch is in the "OFF" position.

The safety interlock system will automatically shut off the engine if the operator leaves the seat before engaging the brake lock.

The safety interlock system will automatically disengage the PTO if the operator leaves the seat with the PTO in the "RUN" position, or the unit is shifted into reverse with the PTO in the "RUN" position. To reengage the PTO, shift into neutral ("N"), move the PTO switch into the "OFF" position and then engage the PTO while seated.

### FUEL TANK

The fuel tank is located in the rear of the tractor. The fuel tank filler cap is located on the center of the fender. (See Figure 7.)

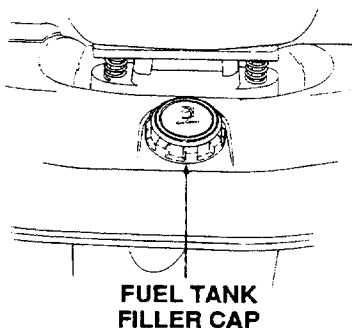

Figure 7

### HOOD AND SIDE PANELS

The tractor hood is arranged to swing up and forward for easy access to the engine compartment. (See Figure 8.) Whenever engine maintenance is required, the side panels can be removed.



### WARNING

If engine is hot, use caution not to burn yourself when removing the side panels.

To remove either right or left side panel, refer to Figure 8 and proceed as follows:

1. Engage the brake lock and raise the hood.
2. Loosen rear wing nut and upper front wing nut.
3. Pull front of side panel from between retainers on grille.
4. Slide side panel forward and out of groove in dash panel.

To install either right or left side panel, refer to Figure 8 and proceed as follows:

1. Slide rear of panel into groove in dash panel.
2. Place rear tab between rear wing nut and bulkhead.
3. Slide slots, on front flange of panel, onto retainers on grille making sure flange is between tapered guide and grille.
4. Tighten rear and upper front wing nuts and close hood.

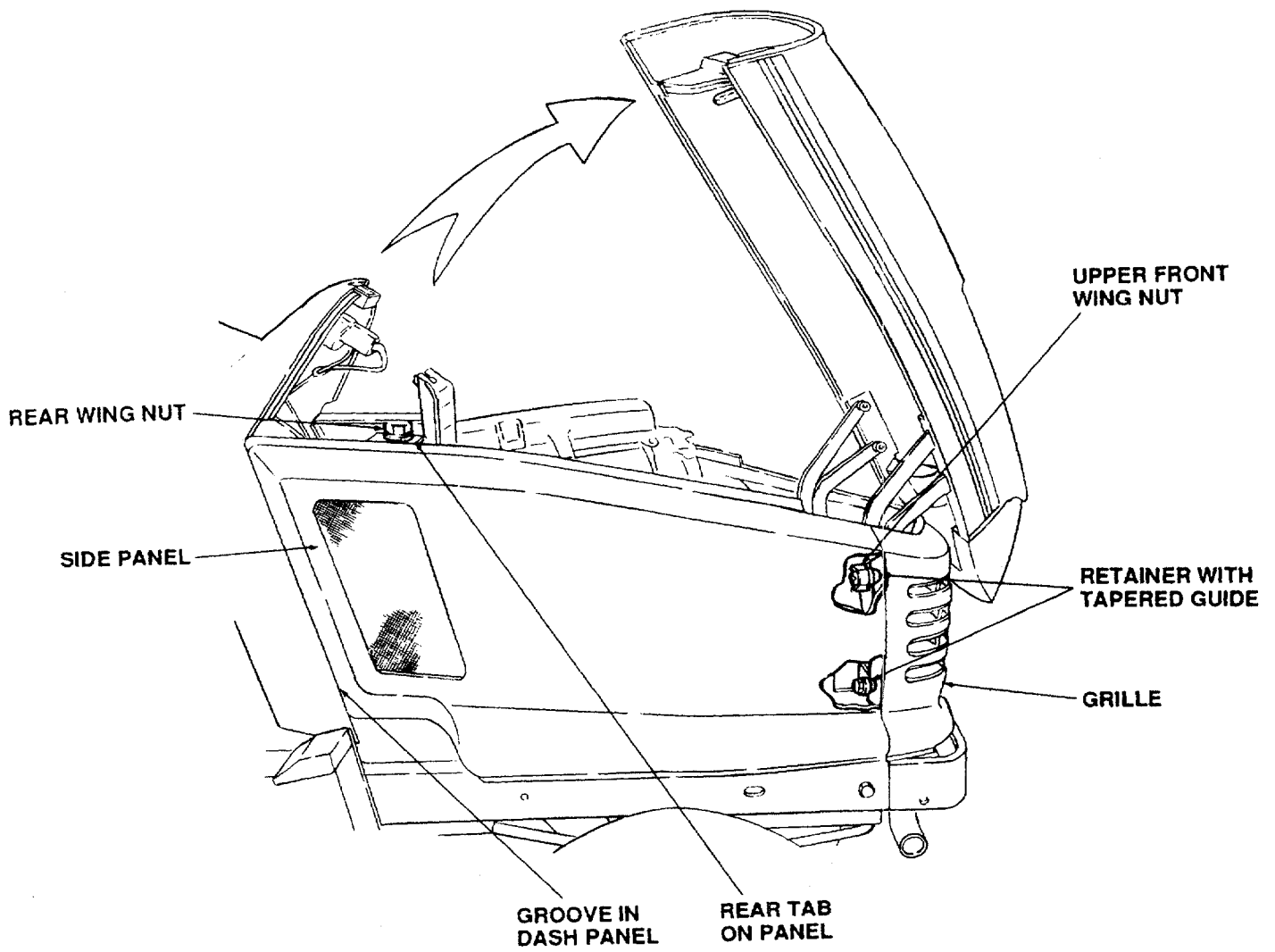

Figure 8

## SECTION II. OPERATION



### WARNING

RECEIVE INSTRUCTION - Read operator's manual. Learn to operate this machine SAFELY. Don't risk INJURY or DEATH.

1. Before starting engine or operation: Be familiar with controls. The operator must be seated with the speed/cruise control lever in the full rearward position, the PTO switch in the "OFF" position and the brake pedal depressed.
2. Keep shields in place. Keep away from moving parts.
3. NO RIDERS! Keep all people and pets a safe distance away. Look before backing up.
4. Don't point mower discharge at people.
5. Avoid slopes. Tractors can be rolled over.
6. Before leaving operator's seat: Shut off PTO. Place speed/cruise control lever in full rearward position. Engage brake pedal lock. Shut off engine. Remove ignition key. Wait for all movement to stop before servicing or cleaning.
7. Do not fill gasoline tank when engine is running or while engine is hot. Tighten cap securely.

### BEFORE OPERATING YOUR TRACTOR

1. Before you operate the tractor study this manual carefully. It has been prepared to help you operate and maintain your tractor with utmost efficiency.
2. Familiarize yourself with the operation of all the instruments and controls.
3. Fill the tank with unleaded gasoline with a pump sticker octane rating of 87 or higher. Unleaded gasohol is acceptable as long as the ethyl alcohol blend does not exceed 10 percent. Make sure before you fill the tank that the gasoline is clean and fresh.
4. Check the engine and transmission oil levels.
5. Clean the air cleaner element if necessary.
6. Check the tire inflation pressures.

7. Adjust the seat for operator's maximum comfort, visibility and complete control of the tractor.
8. Remove the side panels and clean any accumulated grass and debris from the engine inlet air screen. Also clean the dash air intake screen, grille and side panels to ensure adequate cooling.
9. Refer to various sections of the Owner's Manual for additional information.

### STARTING THE ENGINE



### WARNING

Do not operate tractor if the interlock system is malfunctioning. It is a safety device designed for protection of the operator.



### WARNING

Operator must be seated before starting the tractor.



### NOTE

This unit is equipped with a safety interlock system for the protection of the operator.

The safety interlock system prevents the engine from cranking or starting unless the operator is seated, the brake pedal is depressed and the PTO clutch engagement switch is in the "OFF" position.

The safety interlock system will automatically shut off the engine if the operator leaves the seat before engaging the brake pedal lock.



### NOTE

The safety interlock system will automatically disengage the PTO if the reverse control pedal is pressed down with the PTO in the "RUN" position. To reengage the PTO, release the reverse control pedal, move the PTO switch into the "OFF" position and then engage the PTO while seated.

 **NOTE**

The safety interlock system will automatically shut off the tractor engine if the operator leaves the seat with the PTO in the "RUN" position.

1. Operator must be seated.
2. Pull choke control knob to full choke position. Less choking may be necessary due to variations in temperature, grade of fuel, etc. Little or no choking will be needed when the engine is warm.
3. Place the throttle midway between the "SLOW" and "FAST" position.
4. Place the PTO switch in the "OFF" position.
5. Place the speed/cruise control lever in the full rearward position.
6. Fully depress the brake pedal.
7. Turn the ignition key clockwise to the "START" position and release it as soon as the engine starts; however, do not operate the starter for more than 10 seconds at any one time. If the engine does not start within this time, turn the key "OFF" and wait a few minutes, then try again.
8. After the engine starts, slowly release the brake pedal and gradually push the choke control knob all the way in. Do not use the choke to enrich the fuel mixture, except as necessary to start the engine.

**STOPPING THE ENGINE**

 **CAUTION**

Remove the key to prevent accidental starting and battery discharge if equipment is left unattended.

Place the PTO switch in the "OFF" position. Move the throttle lever to the "SLOW" position and allow the engine to idle for a short time before stopping. Then turn the key to the "OFF" position. Remove key from ignition switch.

**TRACTOR BREAK-IN PROCEDURE**

 **CAUTION**

Never operate a new engine immediately under full load. Break it in carefully as shown in the table below.

Period	Engine Throttle Control Lever Position			Load
	1/2	3/4	Full	
1st hour		X		None
2 hour	X		X	Light drawbar load or Mowing with tractor at slow speed
3rd through 13th hour		X	X	Medium drawbar load or Normal mowing

**COLD WEATHER STARTING**

 **WARNING**

During operation do not run the engine in confined area such as storage building any longer than is necessary. Immediately move the tractor outside into the air.

 **WARNING**

Operator must be seated before starting the tractor.

 **NOTE**

In cold weather the starting motor may disengage prematurely. This is caused by the engine firing once but failing to continue running. If this happens several times, the engine will be flooded and it will be necessary to leave the throttle in the "SLOW" position but push the choke in all the way; then turn the ignition key to the "START" position and slowly pull the choke out to the position which will cause the engine to start and continue running. If the engine falters after putting tractor into motion, pull the choke out part way until the engine runs smoothly, then gradually push the choke back in as the engine warms.

Engine starting is possible in cold weather providing the correct weight of engine oil is used, the battery is fully charged and the proper starting procedure is followed. The best procedure for starting at temperatures near or below freezing are as follows:

1. Operator must be seated.
2. Pull the choke all the way out into the full choke position.
3. Move the throttle lever midway between the "SLOW" and "FAST" position.
4. Place the PTO switch in the "OFF" position.
5. Place the speed/cruise control lever in the full rearward position.
6. Fully depress the brake pedal.
7. Move the key switch into the "START" position and hold until the engine starts; however, do not operate the starter for more than 10 seconds at any one time. As soon as the engine starts, slowly push the choke in part way.

#### DRIVING THE TRACTOR (2130 only)



#### CAUTION

Avoid sudden starts, excessive speed and sudden stops.



#### CAUTION

Do not leave the seat of the tractor without disengaging the PTO, depressing the brake pedal and engaging the brake pedal lock. If leaving the tractor unattended, also turn the ignition key off and remove the key.



#### NOTE

When using power take-off operated equipment, best performance is achieved with the throttle lever in the "FAST" position.

1. Depress the brake pedal to release the brake pedal lock and let the pedal up. Move the throttle lever to the position where the engine operates best for the load to be handled.



#### NOTE

When using front or rear mounted equipment refer to Equipment Owner's Manual for proper ground speed for this model.

2. Move the speed control lever slowly forward to desired speed.



#### NOTE

Whatever gear position speed control lever is placed in, the forward control pedal must **always** be fully depressed.

3. Start the tractor in forward motion by depressing the forward control pedal. Start the tractor in reverse motion by depressing the reverse control pedal.



#### CAUTION

Do not use the forward or reverse control pedal to change the direction of travel when the tractor is in motion. Use the brake pedal to bring the tractor to a complete stop before depressing either the forward or reverse control pedal.

4. To change the ground speed of the tractor while it is in motion, the forward or reverse control pedal must be released. The speed control lever can then be moved slowly to the desired speed. The appropriate direction control pedal (forward or reverse) can then be depressed to continue travel.

#### DRIVING THE TRACTOR (2135 only)



#### CAUTION

Avoid sudden starts, excessive speed and sudden stops.





## CAUTION

Do not leave the seat of the tractor without disengaging the PTO, depressing the brake pedal and engaging the brake pedal lock. If leaving the tractor unattended, also turn the ignition key off and remove the key.



## NOTE

When using power take-off operated equipment, best performance is achieved with the throttle lever in the "FAST" position.

1. Depress the brake pedal to release the brake pedal lock and let the pedal up. Move the throttle lever to the position where the engine operates best for the load to be handled.
2. Driving with cruise control lever.



## NOTE

Cruise control can only be operated in a forward speed.

- a. Push lever slowly forward until desired speed is achieved.
  - b. Increase speed by pushing lever forward.
  - c. Decrease speed by pulling lever rearward.
  - d. To stop pull lever all the way rearward or depress brake pedal completely.
  - e. To engage reverse direction when operating with cruise control, stop tractor and depress reverse control pedal.
3. Driving with forward or reverse pedals.



## CAUTION

Do not use the forward or reverse control pedal to change the direction of travel when the tractor is in motion. Use the brake pedal to bring the tractor to a complete stop before depressing either the forward or reverse control pedal.

- a. To move forward, slowly depress forward control pedal until desired speed is achieved.

- b. To move in reverse, fully depress reverse control pedal.

## DRIVING ON SLOPES

Refer to **SLOPE GAUGE** on page 57 in order to help determine slopes where you may not operate safely.



## WARNING

Do not mow on inclines with a slope in excess of 15 degrees (a rise of approximately 2-1/2 feet every 10 feet). A tractor could overturn and cause serious injury.



## WARNING

Operate tractor up and down slopes, never across slopes.



## CAUTION

Always drive up or down the face of a slope. Do not drive so that the tractor may tip over sideways.

Before operating the tractor on any slope, walk the slope to look for possible hazards such as rocks, mounds, ruts, stumps or other surface irregularities which could cause an upset.

Back the tractor with implement up the steepest portion of each slope you intend to work. If the tractor cannot negotiate the slope in reverse, the slope is too steep to be worked.

Avoid turns when driving on a slope. If a turn must be made, turn down the slope. Turning up a slope greatly increases the chance of a roll over.

Avoid stopping when driving up a slope. If it is necessary to stop while driving up a slope, start up smoothly and carefully to reduce the possibility of flipping the tractor over backward.

## STOPPING THE TRACTOR



## CAUTION

Always engage brake pedal lock, push the PTO switch to the "OFF" position, lower equipment and shut off engine before dismounting. Never try to start engine from ground.

Fully depress the brake pedal. When tractor has stopped, make sure the speed/cruise control lever is in the full rearward position. Before dismounting always disengage the PTO, engage the brake pedal lock, turn the ignition "OFF" and remove key from ignition switch.

### **DRAWBAR**

Drawbar equipment must be hitched to the tractor only at the hitch hole in the drawbar. (See Figure 9.)

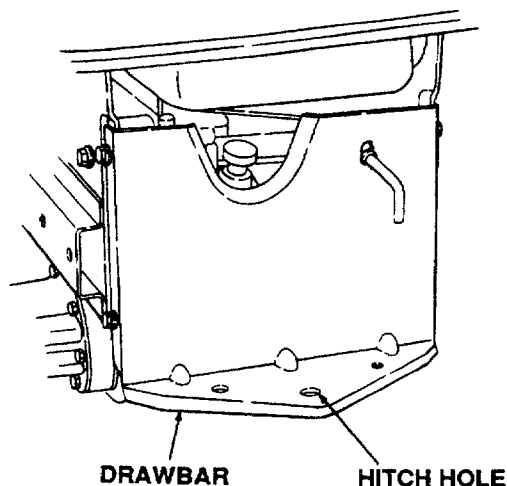

Figure 9

### **OPERATING THE POWER TAKE-OFF (PTO) CLUTCH**



Be certain to follow break-in instructions listed below.

1. Move the throttle lever back to the medium or "SLOW" position.
2. Pull the PTO switch to the "RUN" position.
3. Advance throttle to operating speed (full speed).
4. The operator must remain in tractor seat at all times. If operator should leave tractor seat without turning off the power take-off switch, the tractor engine will automatically shut off.
5. PTO switch must be in the "OFF" position when the reverse control pedal is depressed or the PTO will shut off automatically. To reengage the PTO, release the reverse control pedal. Push the PTO switch to "OFF" position. Pull the PTO switch to the "RUN" position.

### **FRONT PTO CLUTCH BREAK-IN PROCEDURE**

To break in the components and increase the life of the clutch assembly, proceed as follows.

1. Attach mowing deck, snow thrower, etc. to the tractor.
2. Adjust the belt tension as recommended in attachment owner's manual.
3. Run at 50% throttle.
4. Engage and disengage the PTO five times without any load (not cutting grass, not blowing snow, etc.). Ten seconds on/ten seconds off.
5. Increase to 75% throttle.
6. Engage and disengage the PTO five times without any load (not cutting grass, not blowing snow etc.). Ten seconds on/ten seconds off.

## SECTION III. ADJUSTMENTS

This section contains adjustment information for Models 2130 and 2135 tractors. Adjustment information for the 38-inch mower deck is located on page 34 of Section V, Mower Deck.

### ADJUSTING THE SEAT



#### WARNING

Do not adjust the seat when the tractor is moving. Adjusting the seat while the tractor is moving could cause the operator to lose control of the tractor.

Before starting the tractor, adjust the seat forward or rearward to the most comfortable driving position. To reposition the seat, move the seat adjustment lever (Figure 10) upward and slide the seat forward or rearward. Release the adjustment lever when seat is comfortably positioned. Gently rock the seat forward and rearward once to be sure seat is locked in place.

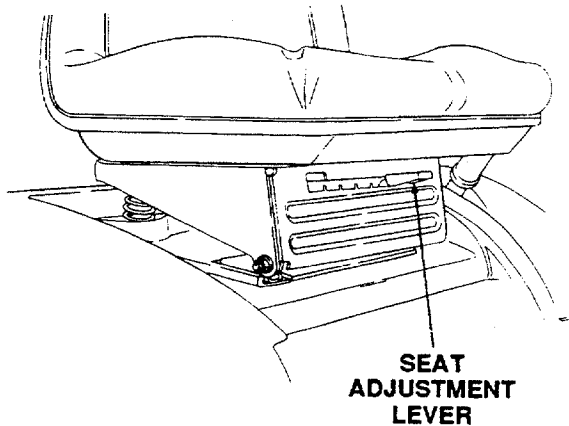

Figure 10

### ADJUSTING THE BRAKES

During normal operation of this tractor, the brakes are subject to wear and will need periodic examination and adjustment.

To check brake adjustment, position tractor on a level surface, then place the speed/cruise control lever in the full rearward position. Stop tractor engine and remove ignition key. On Model 2135 only, place the transmission release lever in the TRANSMISSION RELEASED position. Perform the following checks:

1. Engage the brake pedal lock. If the tractor can be pushed forward or rearward, the brake force must be increased.
2. Release the brake pedal lock. If the tractor cannot be pushed forward or rearward, the brake force must be decreased.

Refer to the following instructions to increase or decrease brake force.

To increase the brake force, refer to Figure 11 and proceed as follows:

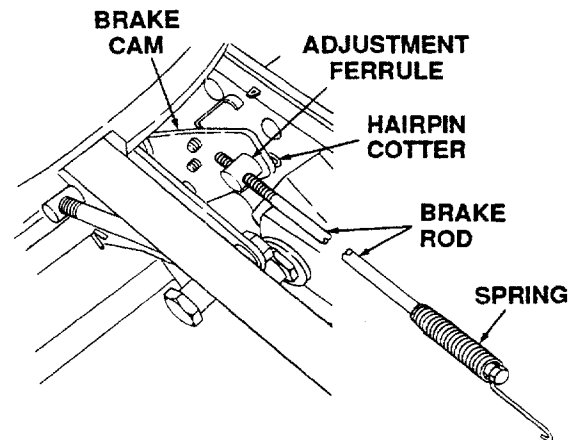

Figure 11

1. Place the tractor on a level surface with the brake pedal lock disengaged. Stop tractor engine and remove ignition key.
2. While working from the underside of the tractor, remove the hairpin cotter from the brake rod adjustment ferrule. Remove ferrule from brake cam.
3. Turn the ferrule clockwise (inward) one full turn at a time until the ferrule can be inserted in the brake cam as **minimum** spring tension is applied.
4. Turn the ferrule counterclockwise (outward) one full turn to release the slight spring tension, then install ferrule in brake cam. Insert the hairpin cotter in the hole of the adjustment ferrule.

Recheck the brake adjustment to ensure proper brake operation before operating the tractor. If the tractor can still be pushed with the brake pedal locked (and transmission released on Model 2135 only), see your authorized *Cub Cadet* dealer.

To decrease the brake force, refer to Figure 11 and proceed as follows:

1. Place the tractor on a level surface with the brake pedal lock disengaged. Stop tractor engine and remove ignition key.
2. While working from the underside of the tractor, remove the hairpin cotter from the brake rod adjustment ferrule. Remove ferrule from brake cam.
3. Turn the ferrule counterclockwise (outward) one full turn at a time until the ferrule can be inserted in the brake cam as **minimum** spring tension is applied.
4. Turn the ferrule counterclockwise (outward) one full turn to release the slight spring tension, then install ferrule in brake cam. Insert the hairpin cotter in the hole of the adjustment ferrule.

Recheck the brake adjustment to ensure proper brake operation before operating the tractor. If the tractor still cannot be pushed with the brake pedal lock released (and the transmission released on Model 2135 only), see your authorized *Cub Cadet* dealer.

### WHEEL ALIGNMENT

The front wheels should toe-in approximately 1/8 inch.

Measure the distances A and B on the front wheels. (See Figure 12.)

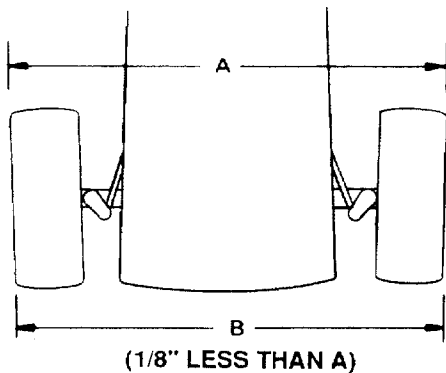

Figure 12



### NOTE

Dimension B should be approximately 1/8 inch less than dimension A.

### FRONT WHEEL ADJUSTMENT

To adjust the toe-in, remove one ball joint, loosen the lock nut at the ball joint and turn the tie rod ball joint in or out as required. Once the required toe-in is achieved, tighten lock nut at the ball joint and reattach ball joint. (See Figure 13.)

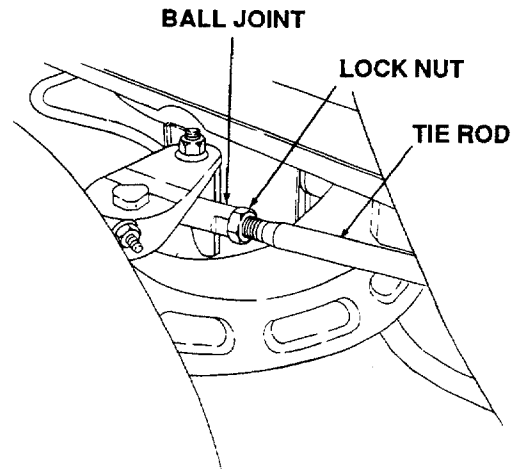

Figure 13

### PIVOT BAR ADJUSTMENT



### CAUTION

The tractor must be checked every 50 hours of tractor operation for play between tractor frame front channel and pivot bar. If binding or excessive play is discovered, pivot bar adjustment bolts must be adjusted.

If binding or excessive play is discovered between tractor frame front channel and pivot bar, adjust both pivot bar adjustment bolts as follows: (See Figure 14.)

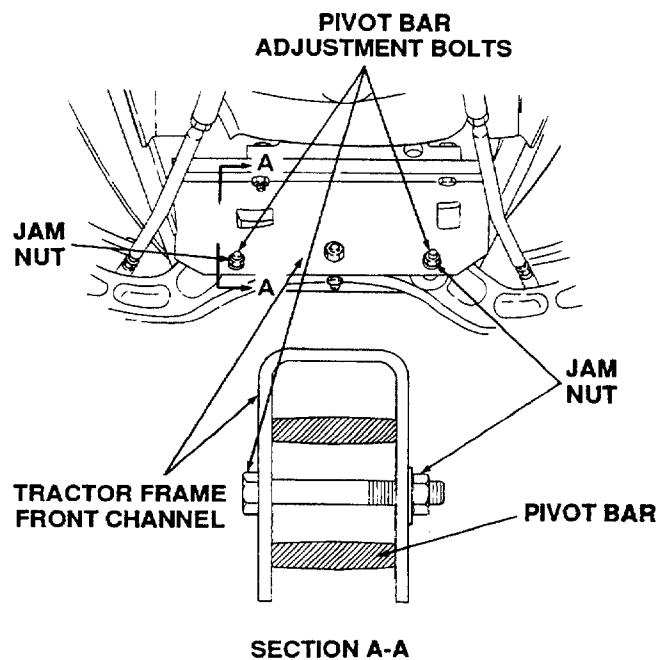

SECTION A-A

Figure 14

1. Raise the front of the tractor and set it on jack stands, so the front wheels and tires are suspended above the ground.



### CAUTION

For safety, block the rear wheels to prevent rolling if the jack stands should slip or slide.

2. Raise and lower a front wheel and tire to check for binding of pivot bar. If binding is discovered, slightly loosen jam nuts, one at a time, until binding is alleviated.
3. Move both front wheels and tires forward and backward to check for excessive play between tractor frame front channel and pivot bar. If excessive play is discovered, slightly tighten jam nut on the side(s) exhibiting excessive play until excessive play is alleviated without binding.
4. Repeat steps 2 and 3 (above) until minimum play without binding is achieved.
5. Raise the front of the tractor, remove the jack stands and lower the tractor. Remove the blocks from the rear wheels.

### HYDROSTATIC NEUTRAL ADJUSTMENT

#### (Model 2135 Tractor only)

The following adjustment may be necessary for the hydrostatic adjustment rod if Model 2135 tractor

creeps forward or rearward without pressing down on either forward or reverse control pedal.

To check the hydrostatic neutral adjustment, proceed as follows:

1. Operate tractor (in gear and moving) for 10 minutes to warm up hydrostatic pump.
2. Place tractor on a level surface with the brake pedal lock disengaged. Stop tractor engine.
3. Raise the rear of tractor and set it on jack stands, so rear wheels and tires are suspended above the ground and are free to rotate.



### CAUTION

For safety, block the front wheels to prevent rolling if the jack stands should slip or slide.

4. Start tractor engine and place cruise control lever in the full rearward position.

If rear wheel rotation is observed, the hydrostatic adjustment rod must be adjusted. While working from the underside of the tractor, refer to Figure 15 and proceed as follows:

1. Hairpin Cotter
2. Pivot Sleeve
3. Trunnion Arm
4. Locknut
5. Centering Gauge Spacer
6. Screw
7. Neutral Hydro Bracket
8. Neutral Arm
9. Hydrostatic Adjustment Rod
10. Ferrule

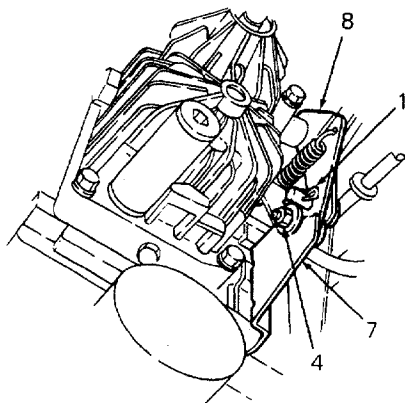

LEFT SIDE VIEW

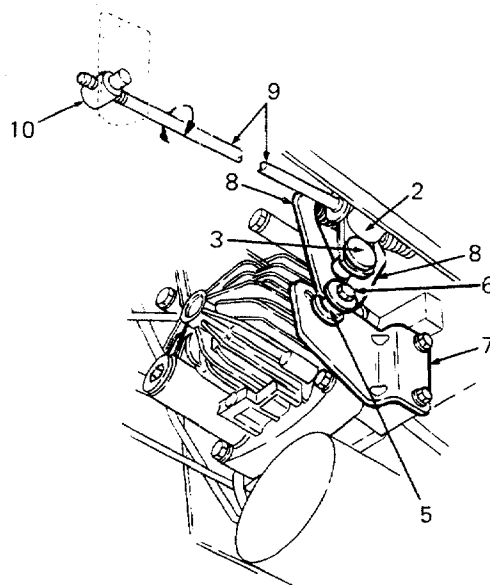

RIGHT SIDE VIEW

Figure 15

1. Remove the hairpin cotter holding the pivot sleeve to the trunnion arm of the hydrostatic pump. Remove pivot sleeve from trunnion arm so hydrostatic adjustment rod is disconnected from trunnion arm.
2. Loosen the locknut securing the centering gauge spacer and screw to the neutral hydro bracket of the hydrostatic pump.
3. Pivot the neutral arm *slightly* forward or rearward while observing the rotation of the rear wheels. Proper adjustment is achieved when rear wheels do not rotate.
4. Tighten locknut to secure the centering gauge spacer and screw to the neutral hydro bracket of hydrostatic pump.
5. Stop tractor engine and engage the brake pedal lock.

**NOTE**

The brake pedal lock **MUST** be engaged for proper alignment during final adjustment.

6. Turn hydrostatic adjustment rod clockwise or counterclockwise (slightly into or out of the forward adjustment ferrule) until the pivot sleeve *loosely* engages the hole in the trunnion arm.
7. With pivot sleeve fully inserted into the hole of the trunnion arm, insert the hairpin cotter into the hole of pivot sleeve.
8. Start tractor engine and disengage brake pedal lock.
9. Observe that the rear wheels do not rotate, indicating proper hydrostatic neutral adjustment, before operating the tractor.
10. Stop tractor engine.
11. Raise the rear of the tractor, remove the jack stands and lower the tractor. Remove the blocks from the front wheels.

**ADJUSTING LIFT ASSIST SPRING TENSION**

The effort required to operate the implement lift handle can be varied by loosening or tightening the lift assist spring adjusting bolt. (See Figure 16.) Turning adjusting bolt clockwise will decrease the manual effort required for lifting attachments; turning counterclockwise will increase the effort required.

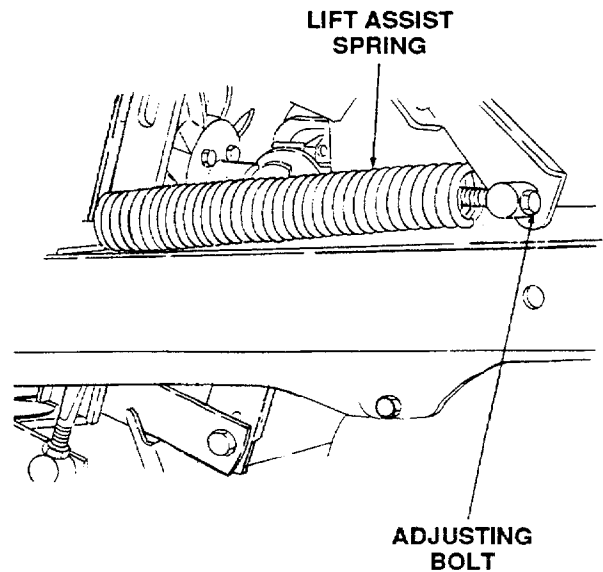

Figure 16

**CARBURETOR ADJUSTMENTS**



**WARNING**

If any adjustments are made to the engine while the engine is running (e.g., carburetor), disengage all clutches and blades. Keep clear of all moving parts and be careful of heated surfaces and muffler.



**WARNING**

To avoid injury or an accident, engage brake pedal lock, place speed/cruise control lever in full rearward position and make sure equipment is disengaged before starting engine to make carburetor adjustments.



**WARNING**

Carbon monoxide fumes can be fatal! Do not make any adjustments to the carburetor in a confined area such as a storage building. Move the tractor outside into the air.



**NOTE**

Carburetor adjustments should be made only after the engine has warmed up.

This engine is equipped with an adjustable jet carburetor. (Refer to Figure 17.)

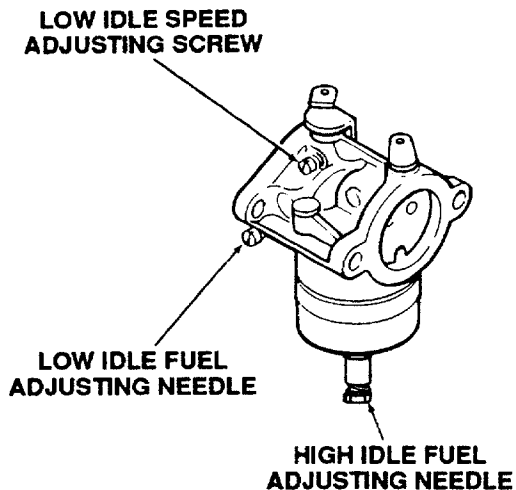

Figure 17

The carburetor is adjusted at the factory and under normal operating conditions it will not require readjusting. However, if the engine does not operate properly, what may appear to be a faulty carburetor adjustment is in many cases a clogged air filter. This possibility should be ruled out before attempting to readjust carburetor. Refer to **MAINTENANCE** section in this manual.

If, however, the engine is hard-starting or runs roughly or stalls at low idle speed, it may be necessary to adjust or service the carburetor.

Minor carburetor adjustment may be required to compensate for differences in fuel, temperature, altitude or load. Air cleaner and air cleaner cover must be assembled to carburetor when running engine.

### Adjust Carburetor

1. With the engine stopped, turn the low and high idle fuel adjusting needles **In** (clockwise) until they bottom *lightly*.



### CAUTION

The tip of the low idle fuel and high idle fuel adjusting needles are tapered to critical dimensions. Damage to the needles and the seats in carburetor body will result if the needles are forced.

2. **Preliminary Settings:** Turn the adjusting needles **out** (counterclockwise) from lightly bottomed to: High Idle 1-1/2 turns; Low Idle 1-1/4 turns.
3. Start the engine and run at half throttle for 5 to 10 minutes to warm up. The engine must be warm before making final settings.
4. **High Idle Fuel Needle Setting:** Place the throttle control into the "fast" position. If possible, place the engine under load.

Turn the high idle fuel adjusting needle **out** (counterclockwise) from the preliminary setting until the engine speed decreases (rich). Note the position of the needle.

Now turn the adjusting needle **In** (clockwise). The engine speed may increase, then it will decrease as the needle is turned in (lean). Note the position of the needle.

Set the adjusting needle **midway** between the rich and lean settings. (See Figure 18.)

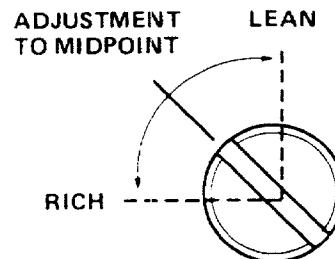

Figure 18

5. **Low Idle Speed Setting:** Place the throttle control into the "idle" or "slow" position. Set the idle speed to **1200 rpm** ( $\pm 75$  rpm) by turning the low idle speed adjusting screw **In** or **out**. Check the speed using a tachometer.

### NOTE

The actual low idle speed depends on the application—refer to equipment manufacturer's recommendations. The recommended low idle speed for basic engines is 1200 rpm. To ensure best results when setting the low idle fuel needle, the low idle speed must not exceed 1500 rpm.

6. **Low Idle Fuel Needle Setting:** Place the throttle into the "idle" or "slow" position.

Turn the low idle fuel adjusting needle **out** (counterclockwise) from the preliminary setting until the engine speed decreases (rich). Note the position of the needle.

Now turn the adjusting needle **in** (clockwise). The engine speed may increase, then it will decrease as the needle is turned in (lean). Note the position of the needle.

Set the adjusting needle **midway** between the rich and lean settings. (See Figure 18.)

7. Recheck the idle speed using a tachometer. Readjust the speed as necessary.



## SECTION IV. MAINTENANCE

### ENGINE OIL

The engine-crankcase is filled with ship-away oil. This oil may be used for the first 5 hours of engine operation at temperatures between 0° and 90°F. If temperatures are not within this range, drain the oil from the oil filter, if installed, and crankcase and replace with new oil as specified in the **LUBRICATION TABLE**. The engine oil must be drained and replaced with new oil after 5 hours of engine operation and then after every 100 hours.

To aid starting, the selection of crankcase lubricating oils should be based on the lowest anticipated temperatures until the next drain period.

For oil change intervals of 100 hours the following oils are recommended.

Ambient Temperature	Viscosity (Grade SF/SG)
+32°F and above —	<i>Cub Cadet</i> Engine Oil S.A.E. 10W30 or S.A.E. 10W40
Below +32°F —	<i>Cub Cadet</i> Engine Oil S.A.E. 5W20 or S.A.E. 5W30

Regularly check the oil level of the engine crankcase to see that it is filled to the correct level. Always keep the oil level between the "FULL" and the "LOW" marks on the dipstick. When checking the oil level, **engine must be cold**, the dipstick must be withdrawn and wiped clean, then inserted all the way and withdrawn for a true reading.

### NOTE

Check the oil level only while the engine is stopped and tractor is level.

### CAUTION

The oil level should be checked every hour during the first 5 hours of operation.

### NOTE

The engine oil level should be checked prior to every use.

### CHECKING OIL LEVEL

Before each use, the oil level of the engine crankcase should be checked to see that it is filled to correct level. Close monitoring of the oil level during the first 10 hours of operation of the engine is especially important. Before checking the oil level, clean the area around the oil fill tube and oil fill cap/dipstick to prevent debris from entering the crankcase. Always keep the oil level between the "FULL" and the "LOW" marks on the dipstick. (See Figure 19.) When checking the oil level, engine must be cold, the dipstick must be withdrawn and wiped clean, then inserted all the way and withdrawn for a true reading.

### NOTE

Check the oil level only while the engine is stopped and tractor is level.

### CAUTION

The oil level should be checked every hour during the first 5 hours of operation.

### NOTE

The engine oil level should be checked prior to every use.

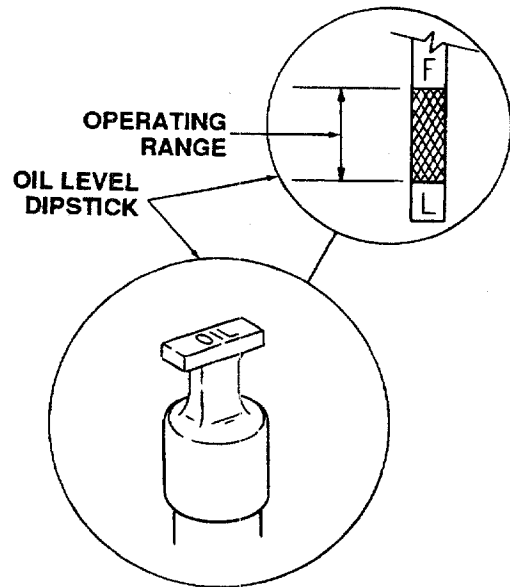

Figure 19

## ADDING OIL



### CAUTION

Never overfill the engine crankcase. Engine may overheat and/or damage may result if the crankcase is below the "LOW" mark or over the "FULL" mark of the dipstick.



### NOTE

For best results, fill to "FULL" mark on dipstick as opposed to adding a given quantity of oil. Always check level on dipstick before adding more oil.

Refer to the **LUBRICATION TABLE** for information regarding the proper type of oil to add to the crankcase.

1. Place the tractor on a level surface and engage the brake pedal lock. Stop tractor engine and remove ignition key.
2. Clean the area around the oil fill tube and oil fill cap/dipstick to prevent debris from entering the crankcase.
3. Remove the oil fill cap/dipstick from oil fill tube and SLOWLY pour oil into the oil fill tube. Fill the crankcase until the oil level reaches the "FULL" mark on the dipstick. (Refer to Figure 19.)
4. Reinstall oil fill cap/dipstick securely into the oil fill tube.



### CAUTION

Oil fill cap/dipstick **MUST BE INSTALLED SECURELY INTO TUBE AT ALL TIMES WHEN ENGINE IS OPERATING.**

## DRAINING OIL AND REPLACING OIL FILTER



### NOTE

The engine oil should be changed after the first 5 hours of operation. Then oil should be changed after every 100 hours of operation.



### WARNING

If engine is hot, use caution not to burn yourself when removing side panels, draining oil from crankcase and changing oil filter.



### NOTE

The oil filter should be changed at every oil change interval. The filters can be obtained through your *Cub Cadet* dealer under part number KH-12-050-08.

Refer to the **MAINTENANCE CHART** and the **LUBRICATION TABLE** for information regarding the frequency of oil change and the quantity and type of oil needed. While the engine oil is warm, proceed as follows:

The oil filter is located behind the left side panel and is mounted on the engine. (See Figure 20.)

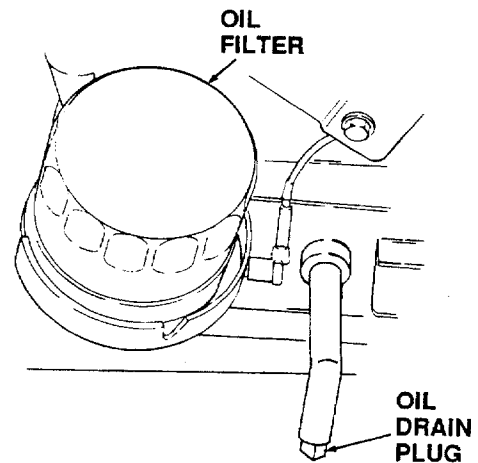

Figure 20

The oil filter is available from your *Cub Cadet* dealer as Part Number KH-12-050-08.



### WARNING

Oil may be hot. Use care to avoid burns from hot oil.

1. Place the tractor on a level surface and engage the brake pedal lock. Stop tractor engine and remove ignition key.
2. Clean around the oil drain plug and remove the plug from the oil drain tube. Collect the old oil in an adequate container. (Refer to Figure 20.)
3. Clean around the base of the oil filter and remove the filter by turning it counterclockwise using an automotive type filter wrench to loosen.
4. Apply a light coating of clean oil on the gasket of the new oil filter. Thread the filter on by hand until gasket seats in oil filter adapter. Tighten the filter an additional 1/2 to 3/4 turn.

5. Install the oil drain plug in the oil drain tube.

Refer to **FILLING THE CRANKCASE** and **LUBRICATION TABLE** and refill the crankcase with the quantity and type of oil specified.

### FILLING THE CRANKCASE



### CAUTION

Never overfill the engine crankcase. Engine may overheat and/or damage may result if the crankcase is below the "LOW" mark or over the "FULL" mark of the dipstick.



### NOTE

For best results, fill to "FULL" mark on dipstick as opposed to adding a given quantity of oil. Always check level on dipstick before adding more oil.

Refer to the **LUBRICATION TABLE** for information regarding the oil capacity and the proper type of oil to pour into the crankcase.

1. Place the tractor on a level surface and engage the brake pedal lock. Stop tractor engine and remove ignition key.
2. Clean the area around the oil fill tube and oil fill cap/dipstick to prevent debris from entering the crankcase.
3. Remove the oil fill cap/dipstick from oil fill tube and **SLOWLY** pour oil into the oil fill tube. The oil capacity is approximately 4 pints. Fill the crankcase until the oil level reaches the "FULL" mark on the dipstick. (Refer to Figure 19.)
4. Reinstall oil fill cap/dipstick securely into the oil fill tube.



### CAUTION

Oil fill cap/dipstick **MUST BE INSTALLED SECURELY INTO TUBE AT ALL TIMES WHEN ENGINE IS OPERATING.**

5. Start tractor engine and allow it to run for 30 seconds. After 30 seconds, stop engine and remove ignition key.
6. Check the oil level and add oil if necessary. **DO NOT OVERFILL THE ENGINE CRANKCASE.**

7. Check for leaks around the oil filter and at the drain plug.

### CHECKING TRANSMISSION OIL LEVEL



### NOTE

Check the oil level only while the engine is stopped and tractor is level.

Check the oil level of the transmission case before each use to see that it is filled to the correct level. Before checking the transmission oil level, clean the area around the oil fill plug/dipstick to prevent debris from entering the transmission case. Always keep the oil level between the "FULL" and the "ADD" marks on the dipstick. (See Figure 21.) When checking the oil level, the dipstick must be withdrawn and wiped clean, then inserted all the way and withdrawn for a true reading.

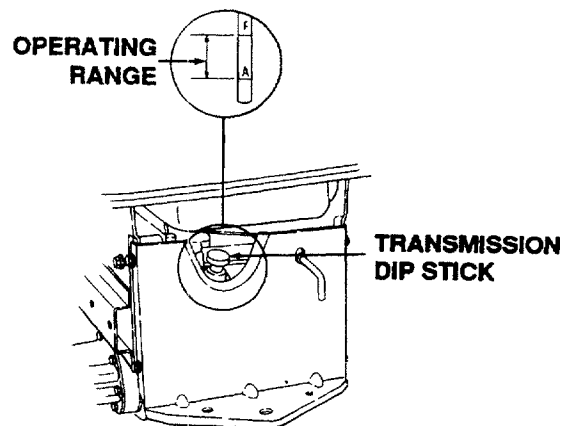

Figure 21

### ADDING TRANSMISSION OIL



### CAUTION

Never overfill the transmission case. Damage may result if the transmission case is below the "ADD" mark or over the "FULL" mark of the dipstick.



### NOTE

For best results, fill to "FULL" mark on dipstick as opposed to adding a given quantity of oil. Always check level on dipstick before adding more oil.

Refer to the **LUBRICATION TABLE** for information regarding the proper type of oil to add to the transmission case.

1. Place the tractor on a level surface and engage the brake pedal lock. Stop tractor engine and remove ignition key.
2. Clean the area around the oil fill plug/dipstick to prevent debris from entering the transmission case.
3. Remove the oil fill plug/dipstick from oil fill port and SLOWLY pour oil into the oil fill port. Fill the transmission case until the oil level reaches the "FULL" mark on the dipstick. (Refer to Figure 21.)
4. Reinstall oil fill plug/dipstick securely into the oil fill port.



### CAUTION

Oil fill plug/dipstick **MUST BE INSTALLED SECURELY INTO FILL PORT AT ALL TIMES WHEN ENGINE IS OPERATING.**

### HYDROSTATIC DRIVE OIL FILTER (MODEL 2135)



### CAUTION

Never overfill the transmission case. Damage may result if the transmission case is below the "ADD" mark or over the "FULL" mark of the dipstick.



### NOTE

For best results, fill to "FULL" mark on dipstick as opposed to adding a given quantity of oil. Always check level on dipstick before adding more oil.

Refer to the **MAINTENANCE CHART** for information regarding the frequency of the hydrostatic transmission oil filter replacement. The filter can be obtained through your *Cub Cadet* Dealer under Part Number 723-3014.

Refer to the **LUBRICATION TABLE** for information regarding the oil capacity and proper type of oil to pour into the transmission case.

1. Place the tractor on a level surface and engage the brake pedal lock. Stop tractor engine and remove ignition key.

2. Clean the area around the transmission drain plug. Remove the drain plug and allow the transmission oil to drain into a clean container having a capacity of more than 6 quarts. Replace drain plug. (Refer to Figure 22.)

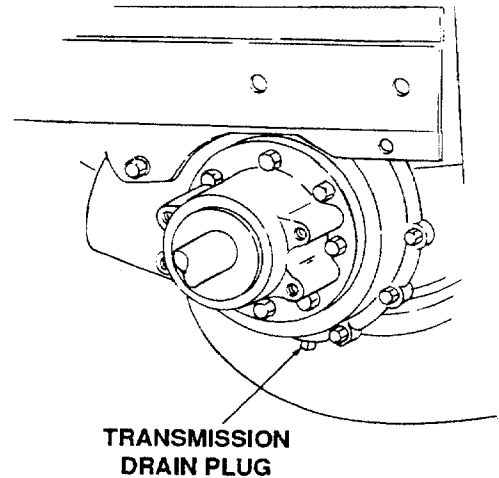

Figure 22



### CAUTION

If transmission oil is to be reused, cover container holding drained oil to prevent contamination. Contaminated transmission oil can damage your unit.

3. Clean around the base of the transmission oil filter and remove filter by turning it counterclockwise. (Refer to Figure 23.)

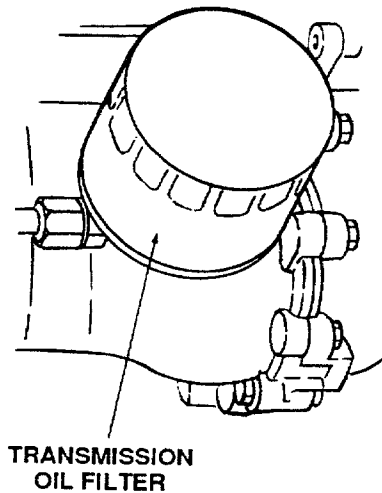

Figure 23

4. Apply a light coat of clean transmission oil to the gasket of the new filter. Install the filter by turning it clockwise, by hand, until the gasket contacts the base. Loosen the filter by turning it counterclockwise. Again install the filter by turning it clockwise until the gasket contacts the base.  
Tighten filter an additional 1/2 turn.
5. Clean the area around the transmission oil fill plug/dipstick to prevent debris from entering the transmission case.
6. Remove the oil fill plug/dipstick from oil fill port and SLOWLY pour oil into the oil fill port. Fill the transmission case until the oil level reaches the "FULL" mark on the dipstick. (Refer to Figure 21.)
7. Reinstall oil fill plug/dipstick securely into the oil fill port.
8. Start engine and allow it to run for a few minutes. Shut engine off and check for leaks; check oil level in transmission case.



### CAUTION

Oil fill plug/dipstick **MUST BE INSTALLED SECURELY INTO PORT AT ALL TIMES WHEN ENGINE IS OPERATING.**

### AIR CLEANER

Check the air cleaner daily or before starting the engine. Check for and remove any heavy buildup of dirt and debris, and loose or damaged components.



### NOTE

Operating the engine with loose or damaged air cleaner components could allow unfiltered air into the engine causing premature wear and failure.

### Service Precleaner

Wash and reoil the foam precleaner at 1-month intervals or after every 10 hours of operation (more often under extremely dusty or dirty conditions), whichever occurs first.

1. Remove the air cleaner cover retaining knob, air cleaner cover and paper element with foam pre-cleaner. (See Figure 24.)
2. Remove the foam precleaner by sliding it up off the paper element. (See Figure 25.)

3. Wash the precleaner in warm water with detergent. Rinse the precleaner thoroughly until all traces of detergent are eliminated. Squeeze out excess water in a dry cloth (do not wring). Allow the precleaner to air dry.

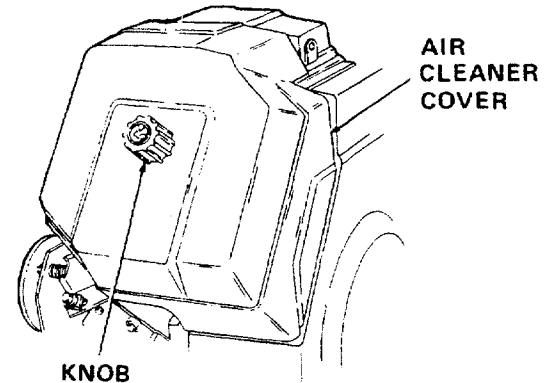

Figure 24. Air Cleaner Housing Components

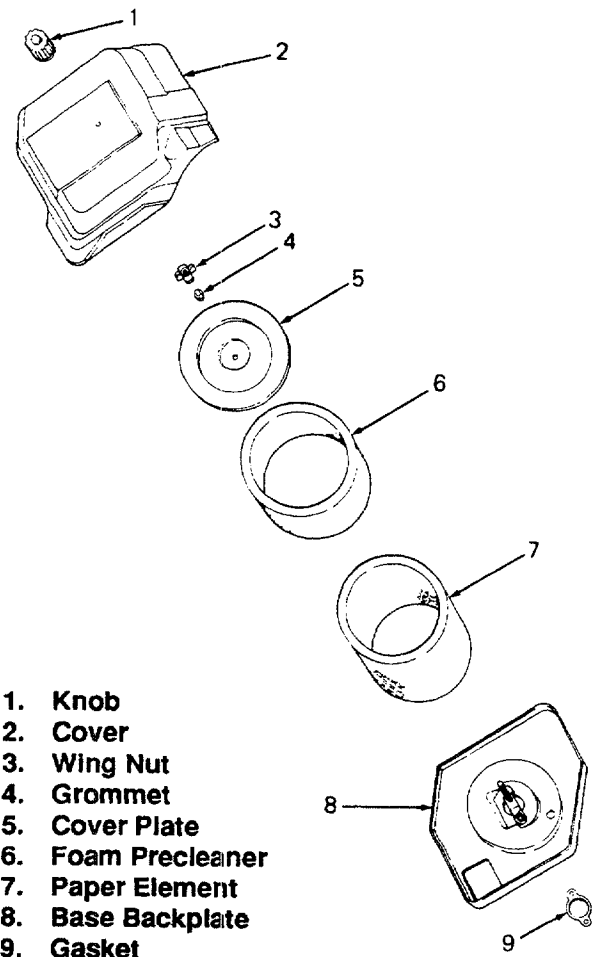

Figure 25. Air Cleaner Elements

4. Saturate the foam precleaner with new engine oil. Squeeze out all excess oil in a dry cloth.
5. Reinstall the foam precleaner over the paper element.
6. Reinstall the paper element with foam precleaner, air cleaner cover and air cleaner cover retaining knob. Make sure the knob is tightened securely.

### Service Paper Element

Every 100 hours of operation (more often under extremely dusty or dirty conditions), check the paper element. Replace the element as necessary.

1. Remove the air cleaner cover retaining knob, air cleaner cover and paper element with foam pre-cleaner. (See Figure 24.)
2. Remove the foam precleaner by sliding it up off the paper element. (See Figure 25.)
3. Do not wash the paper element or use pressurized air, as this will damage the element. Replace a dirty, bent or damaged element. Handle new elements carefully; do not use if the sealing surfaces are bent or damaged.
4. When servicing the air cleaner, check the air cleaner base. Make sure it is secured and not bent or damaged. Also check the air cleaner cover for damage or improper fit. Replace all damaged air cleaner components.
5. Reinstall the paper element, foam precleaner, air cleaner cover and air cleaner cover retaining knob. Make sure the knob is tightened securely.

Properly cleaned and installed air cleaner elements significantly contribute to prolonged engine life.

### CLEANING ENGINE

This tractor has an air-cooled engine. Air must be able to circulate freely around the engine, through the screen, shroud and over the fins of the cylinder head and cylinder block. Keep these areas free of accumulated dirt and trash or engine will overheat and result in damaged moving parts. Periodically clean the inside of the side panels, dash intake screen and grill to ensure adequate cooling.



This machine is designed to cool properly with the engine side panels in place. Operating the machine without panels in place may result in inadequate cooling.

### SPARK PLUG



### WARNING

To avoid possible injury, be sure engine is off and cool before making any adjustment or repairs.



### NOTE

Remove all dirt from around the spark plug before removing.

To remove spark plug, always use a spark plug wrench. Check gap after every 100 hours of operation.

Replace a defective plug with a new plug. Set gap at .040 inch. (See Figure 26.) Tighten plug to 28-32 ft-lbs. See your authorized dealer for the correct replacement plug.

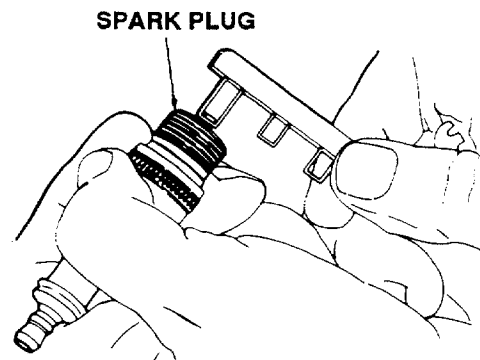

Figure 26

### FUEL FILTER



### WARNING

Do not replace the fuel filter when engine is hot.

The engine is equipped with an inline fuel filter. Visually inspect the filter periodically, and replace when dirty.

### LIGHTS

Refer to **SPECIFICATIONS** when replacement of head lamp bulb is necessary.



## WARNING

Do not change head lamp bulbs when hot or when engine is hot.



## CAUTION

Do not touch glass portion of head lamp bulb. Touching glass portion will reduce life of head lamp bulb.

To replace a head lamp bulb, refer to Figure 27 and remove the socket from the housing by rotating socket 1/4 turn. Pull old bulb assembly from socket and insert new bulb assembly. Do not touch the glass portion of the head lamp bulb. Place socket into housing and turn to lock in place.

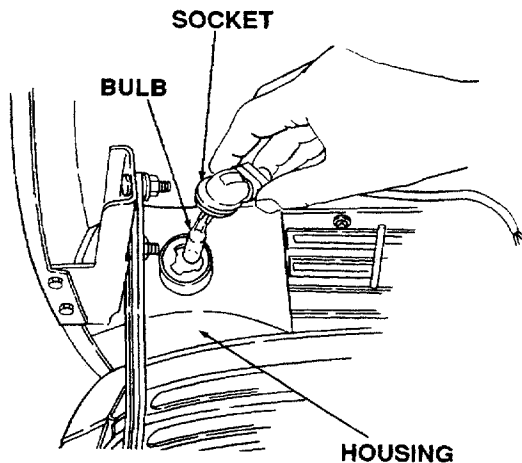

Figure 27

## FUSE

Always use the same capacity fuse for replacement. Refer to "SPECIFICATIONS." If electrical system malfunctions, check the fuse.

To replace a new fuse, pull the old fuse from the fuse housing and install a new fuse.

## BATTERY INFORMATION



## WARNING

- A. Battery acid must be handled with great care as contact with it can burn and blister the skin. It is also advisable to wear protective clothing (goggles, rubber gloves and apron) when working with it.\*

- B. Should battery acid accidentally splatter into the eyes or onto the face, rinse the affected area immediately with clean cold water. If there is any further discomfort, seek prompt medical attention.
- C. If acid spills on clothing, first dilute it with clean water, then neutralize with a solution of ammonia/water or baking soda/water.
- D. Since battery acid is corrosive, do not pour it into any sink or drain. Before discarding empty electrolyte containers, rinse them with a neutralizing solution.
- E. NEVER connect or disconnect charger clips to battery while charger is turned on as it can cause sparks.
- F. Keep all lighted materials (cigarettes, matches, lighters) away from the battery as the hydrogen gas generated during charging can be combustible.
- G. As a further precaution, only charge the battery in a well-ventilated area.

\*Always shield eyes and protect skin and clothing when working near batteries.



## DANGER

BATTERIES CONTAIN SULFURIC ACID AND MAY CONTAIN EXPLOSIVE GASES (when electrolyte has been added).

KEEP BATTERIES OUT OF THE REACH OF CHILDREN.

## MAINTENANCE OF BATTERY

1. Check electrolyte level periodically (at least every two weeks). Keep the level to the split rings. Use only distilled water or a good quality drinking water. Never add acid or any other chemicals to the battery after initial activation.
2. The battery should be checked with a hydrometer after every 25 hours of operation. If the specific gravity is less than 1.225, the battery should be recharged. Maximum charge rate is 5 amps.
3. Coat the terminals and exposed wire with a thin coat of grease or petroleum jelly for longer service and protection against corrosion.
4. The battery should be kept clean. Any deposits of acid should be neutralized with baking soda and water. Be careful not to get this solution in the cells.

- Avoid tipping the battery. Even a "sealed" battery will leak electrolyte when tipped.

### STORAGE OF THE BATTERY

- When storing battery for extended periods, disconnect battery cables. Removing battery from unit is recommended.
- Keep the exterior of the battery clean, especially the top. A dirty battery must be stored with a full charge. A dirty battery will discharge itself.
- Check the battery with a hydrometer. The battery must be stored with a full charge. A discharged battery will freeze.

Specific Gravity	Freezing Point
1.265	-71°F
1.250	-62°F
1.200	-16°F
1.150	5°F
1.100	16°F



All batteries discharge during storage.

- Recharge battery whenever the specific gravity is less than 1.225, before returning to service or every two months, whichever comes first.

### COMMON CAUSES FOR BATTERY FAILURE

- Overcharging
- Undercharging
- Lack of water
- Loose hold downs and/or corroded connections
- Excessive loads
- Battery electrolyte substitutes
- Freezing of electrolyte



These failures do not constitute warranty.

### BATTERY REMOVAL OR INSTALLATION



#### WARNING

When removing the battery, follow this order of disassembly to prevent your wrench from shorting against the frame.

Battery removal:

- Remove the Negative cable.
- Remove the Positive cable.

Battery installation:

- Attach the Positive cable.
- Attach the Negative cable.

### JUMP STARTING



#### WARNING

Failure to use this starting procedure could cause sparking, and the gases in either battery could explode.

- Attach the first jumper cable from the positive terminal of the good battery to the positive terminal of the dead battery.
- Attach the second jumper cable from the negative terminal of the good battery to the FRAME OF THE UNIT WITH THE DEAD BATTERY.

### TIRES

Keep the pneumatic tires properly inflated. Overinflation will cause operator discomfort. Underinflation will cause short tire life.

Inflate the front and rear tires for normal or heavy load operations as shown in the following table:

Tire Size	Pounds per Square Inch
Front Tires – 15 x 6-6	14
Rear Tires – 20 x 9-8	10

Always see that the tire valve caps are in place and tightened securely to prevent loss of air and protect the valve core and stem.

Do not overload the tractor tires by mounting equipment on the tractor which exceeds the load capacity of the size of the tires on the tractor.



## MOUNTING TIRES ON THE RIM



### **WARNING**

Do not mount a tire unless you have the proper equipment. Do not inflate tire above the recommended pressure. Do not stand in front of or over tire assembly when inflating. Explosive separation of tire and rim can cause injury or death.

After mounting a new or old tire on the rim, inflate it to 20 pounds pressure to seat the tire bead on the rim flange. Then deflate the tire to the correct operating pressure.



### **NOTE**

After the first 10 hours of operation, check and retorque the wheel lug nuts (both sides) to 35 ft-lbs. to make sure they have seated properly.

## SECTION V. MOWER DECK

This section contains adjustment, removal and installation and maintenance information for the 38-inch mower deck.

### A. DECK LEVELING ADJUSTMENTS

In order to achieve even cutting, the mower deck must be properly leveled. This leveling procedure will result in the left and right blades having corresponding front cutting-edge-to ground measurements within 1/16 inch of each other. Also, the right and the left blades will each have a 1/16 to 1/8 inch downward tilt toward the front of the tractor. To level the mower deck, proceed as follows:



#### WARNING

Before making any adjustments, place the PTO switch in the "OFF" position, engage the brake pedal lock, turn the ignition key to the "OFF" position, remove key from switch and remove the spark plug wire to avoid accidental starting and injury.



#### WARNING

When adjusting the mower deck, be careful not to cut yourself on the sharp blades.



#### NOTE

If the mower deck is not level, the mower will not cut your lawn evenly.



#### NOTE

Check the tires for proper inflation before making a level adjustment. To level the deck, the tractor and deck **MUST** be placed on a hard, level surface during adjustment.

### SIDE-TO-SIDE LEVELING ADJUSTMENT

1. Position the tractor and mower deck on a hard, level surface.
2. Open the tractor hood and disconnect the spark plug wire.
3. The mower deck rear gauge wheels must be set to their uppermost positions in the deck brackets, so the deck rests at its lowest position, relative to the hard, level surface below. Refer to **GAUGE WHEEL ADJUSTMENT**.
4. Raise the tractor implement lift handle to its highest setting.
5. Position the mower blades so that the ends of each blade face the right and left sides of the tractor. (Refer to Figure 28.)

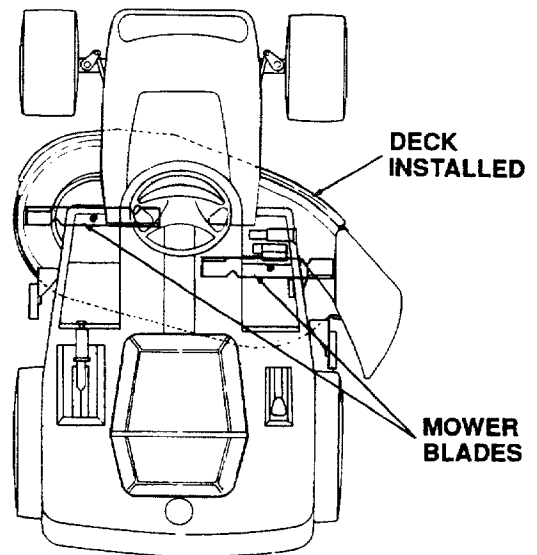
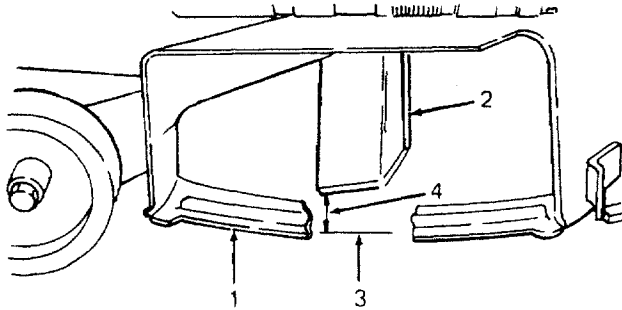

Figure 28

6. Refer to Figure 29 and measure and record the distance from the hard, level surface to the outermost cutting edge of the right blade. Repeat this step for the left blade. If the two blade heights are not within 1/16 inch, proceed to steps 7, 8 and 9. If the two blade heights are within 1/16 inch, proceed to **FRONT TO BACK LEVELING ADJUSTMENT**.



1. Deflector Shield
2. Blade
3. Hard Level Surface
4. Measure This Surface

Figure 29

7. Lower the deck onto the hard, level surface.
8. Side-to-side leveling is obtained utilizing the adjustment ferrule and left hand hanger bracket. (Refer to Figure 30.)

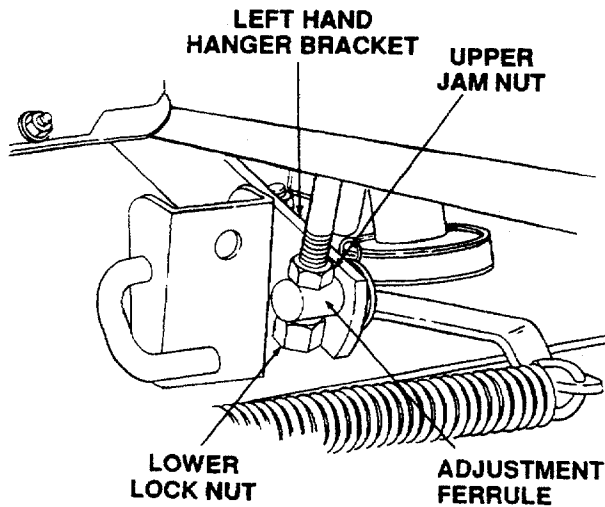

Figure 30

9. Loosen upper jam nut on hanger bracket. Turn lower lock nut clockwise to raise left side of mower deck. Turn lock nut counterclockwise to lower left side of mower deck. (Refer to Figure 30.)
10. Raise the lift handle to the highest position and recheck the blade measurements described in step 6. If the blade measurements are not within 1/16 inch, repeat steps 7, 8 and 9.
11. Tighten upper jam nut after adjustment is completed.

### FRONT TO BACK LEVELING ADJUSTMENT

1. Raise the deck to its highest position.
2. Position the mower blades so the ends of each blade point to the front and to the rear of the tractor. (Refer to Figure 31).

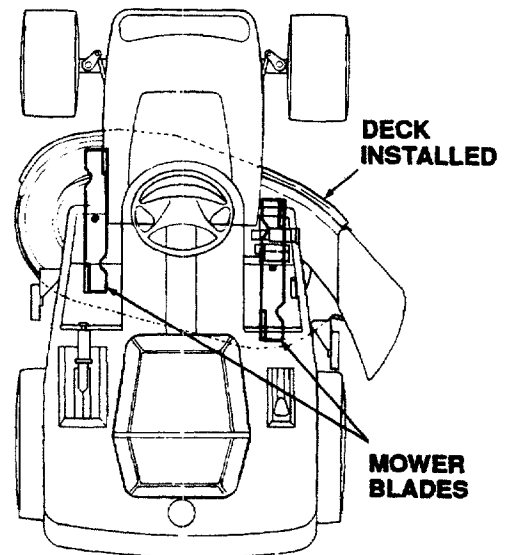

Figure 31

3. Initially adjust the front lift rod to allow 5/8 inch of thread to protrude above both lock nuts of the front lift rod bracket. (Refer to Figure 32.)

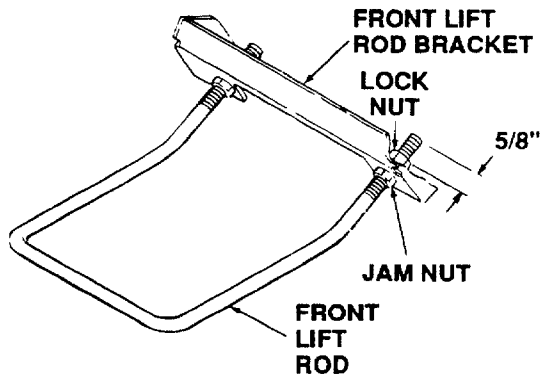

Figure 32

4. Refer to Figure 33. Measure and record the distance from the front cutting edge to the ground (measurement A), and from the rear cutting edge to the ground (measurement B), for each of the outside blades. The front edge of each blade (measurement A) should be lower than its back edge (measurement B) by 1/16 to 1/8 inch.
5. Lower the deck onto the hard, level surface.
6. To adjust the downward tilt of the blades, adjustment of the front lift rod is required. Refer to Figure 32 and proceed as follows:
7. Loosen rear jam nuts on front lift rod and turn front lock nuts clockwise to raise front of mower deck or counterclockwise to lower front of mower deck.
8. Raise the deck to the highest position. Recheck the blade measurements described in step 4. If the resultant measurements are not correct, repeat steps 5, 6 and 7 until proper measurements are obtained.
9. Tighten rear jam nuts after adjustment is completed.
10. Connect the spark plug wire.

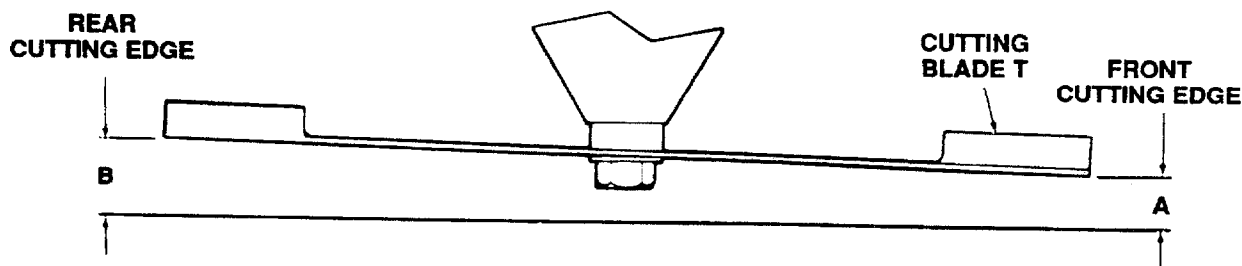

Figure 33

## GAUGE WHEEL ADJUSTMENT



### WARNING

Before making any adjustments, place the PTO switch in the "OFF" position, engage the brake pedal lock, turn the ignition key to the "OFF" position, remove key from switch and remove the spark plug wire to avoid accidental starting and injury.



### WARNING

When adjusting the mower deck, be careful not to cut yourself on the sharp blades.



### NOTE

Gauge wheel adjustment should be performed only AFTER the mower deck has been properly leveled.



### NOTE

Gauge wheels prevent lawn scalping and are not meant to be used to set the cutting height.

In order to adjust the height of the rear gauge wheels, refer to Figure 34, and proceed as follows:

1. Raise the tractor implement lift handle to its highest setting.
2. Remove the lock nut from the shoulder screw securing the gauge wheel to the gauge wheel bracket.
3. Remove the gauge wheel with the shoulder screw and flat washer from the gauge wheel bracket.

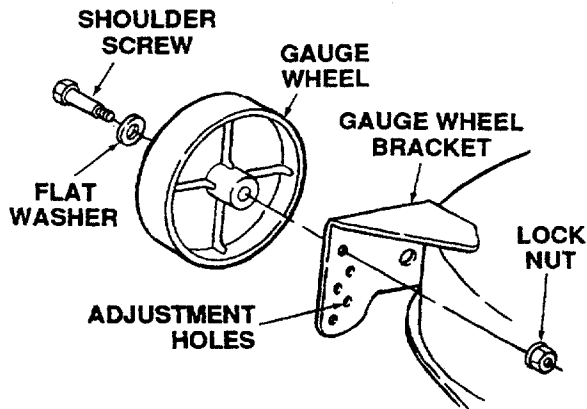

Figure 34

4. Insert the shoulder screw and flat washer with the gauge wheel into the gauge wheel bracket adjustment hole that provides the desired height.
5. Install the lock nut on the shoulder screw to secure the gauge wheel to the gauge wheel bracket.
6. Repeat the above procedure for the remaining gauge wheel using the same relative adjustment hole location of the remaining gauge wheel bracket.

**NOTE**

Both rear gauge wheels must be installed in the same relative adjustment hole locations of both gauge wheel brackets.

**CUTTING HEIGHT ADJUSTMENT**

The mower can be set in multiple positions. Proceed as follows:

**NOTE**

Check the tires for proper inflation before making a height adjustment.

1. Pull the tractor implement lift handle up slightly and depress the button on the top of the lift handle.
2. Raise or lower the lift handle to obtain the desired mower deck cutting height.
3. Release the button when the desired mower position is obtained.

**NOTE**

To return the mower deck to a specific position, note the position of the lift lever indicator before raising or lowering the mower deck.

**B. REMOVAL AND INSTALLATION OF DECK ASSEMBLY**

**REMOVAL OF DECK**

**WARNING**

Before performing the mower deck removal, place the PTO switch in the "OFF" position, engage the brake pedal lock, turn the ignition key to the "OFF" position and remove key from switch.

**WARNING**

When handling the mower deck, be careful not to cut yourself on the sharp blades.

**WARNING**

The tractor and mower deck must be placed on a hard, level surface during removal.

1. Position the tractor and mower deck on a hard, level surface.
2. Open the tractor hood and disconnect the spark plug wire.
3. Lower the tractor implement lift handle to its lowest setting. Disengage the deck idler arm lever from its stop bracket and then release the spring tension until the lever is at the outside of the deck. (Refer to Figure 35.)

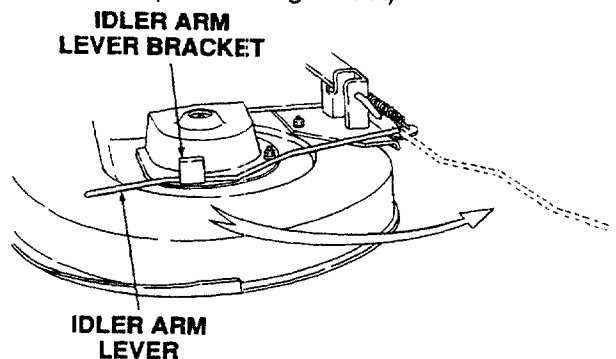

Figure 35

- Remove the rearward end of the PTO belt from the upper pulley of the deck center double-pulley. (Refer to Figure 36.)

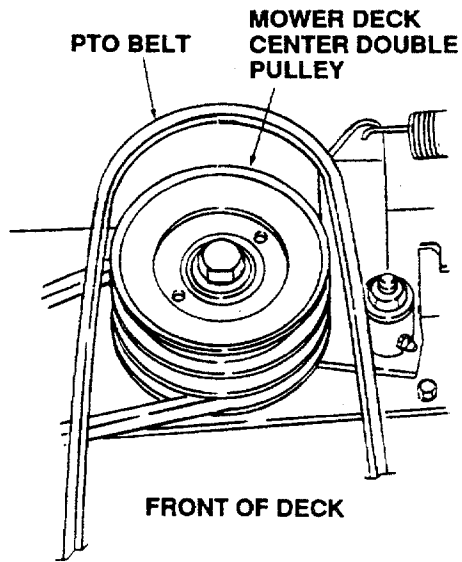

Figure 36

- Engage the deck idler arm lever into its stop bracket. (Refer to Figure 37.)

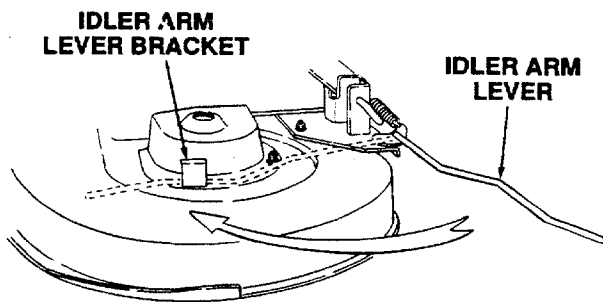

Figure 37



**WARNING**

The exhaust system is **HOT**. To avoid personal injury, allow the engine and exhaust system to cool before proceeding with the following PTO belt removal instructions.

- Remove the forward end of the PTO belt from the engine PTO clutch pulley. (Refer to Figure 38.)

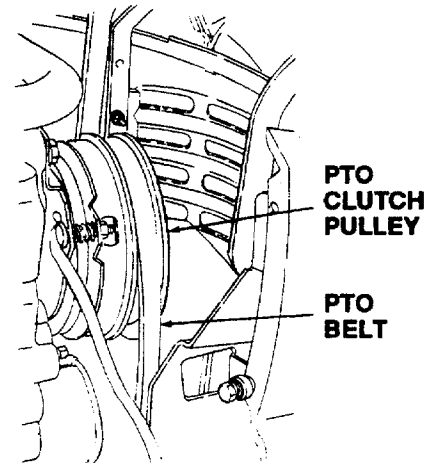

Figure 38

- Pass the PTO belt downward, inside the tractor frame, until the belt is below the two tractor front-lower pulleys. (Refer to Figure 39.)

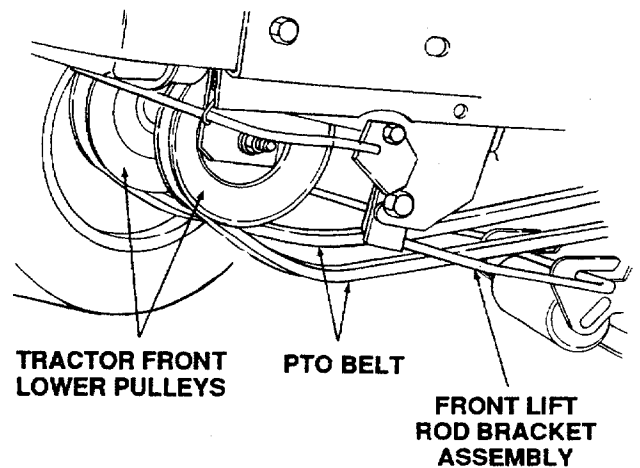

Figure 39

- From the front of the tractor, pull the PTO belt clear of the tractor.

9. Pull the deck rear bracket pins outward, turn downward and release so both spring-loaded pins are held against the outside surface of the brackets in their disengaged positions. (Refer to Figure 40.)

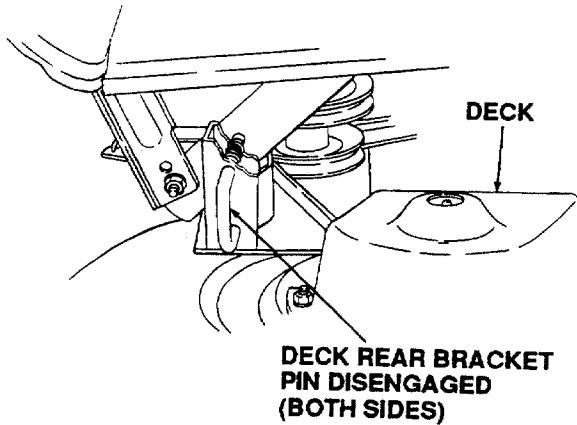

Figure 40

10. Raise the tractor implement lift handle to its highest setting. Slide the mower deck forward, so the front lift rod rests to the rear of, and free of, the front roller bracket slots of the deck. (Refer to Figure 41.)

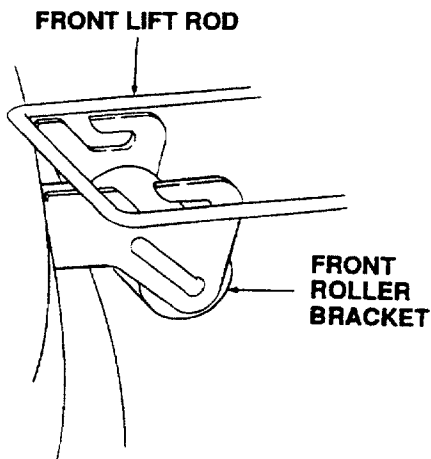

Figure 41

1. Hold the front lift rod upward and slide the mower deck rearward. Lower the front lift rod, so it rests to the front of, and free of, the front roller bracket slots of the deck. (Refer to in Figure 42.)

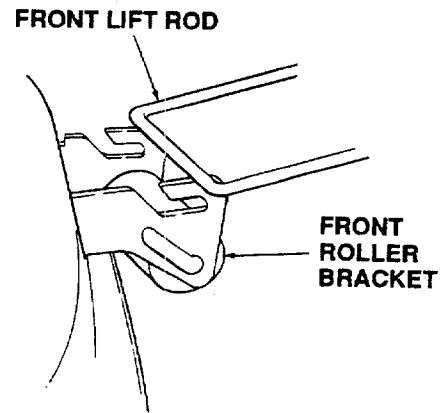

Figure 42

12. Referring to Figure 43, push downward and hold the tractor quick-attach rod. Slide the left and right shoulder bolts of the front lift rod bracket assembly forward, and free of, the left and right tractor latch receivers. Release the tractor quick-attach rod.

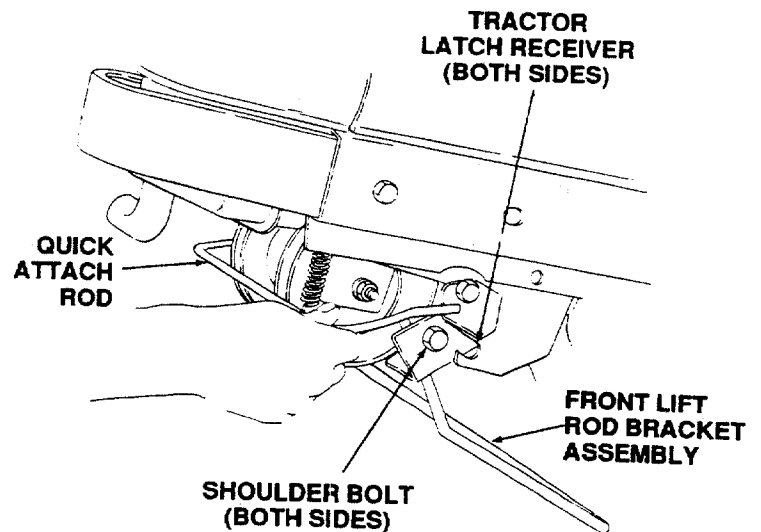

Figure 43



## CAUTION

To avoid possible equipment damage, make sure that the tractor implement lift handle is raised to its highest setting before sliding the deck out from under the tractor.

13. With the tractor implement lift handle raised to its highest setting, slide the deck to the right and out from under the tractor. (Refer to Figure 44.)

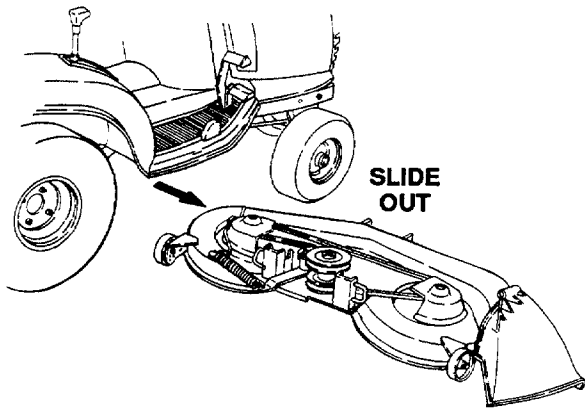

Figure 44

3. Refer to Figure 45 and position the deck on the right side of the tractor with the front of the deck facing toward the front of the tractor. Raise the tractor implement lift handle to its highest setting and slide the deck under the tractor.

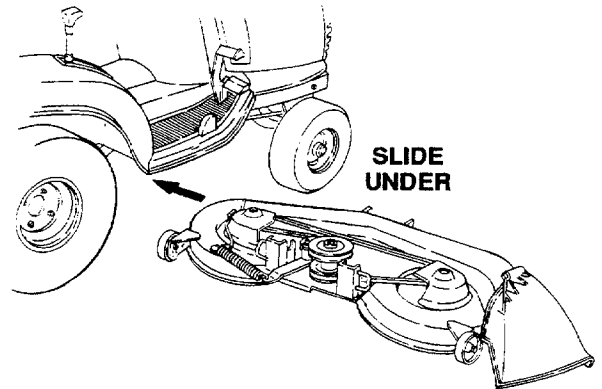

Figure 45

14. Connect the spark plug wire.

#### INSTALLATION OF DECK



#### WARNING

Before performing the mower deck installation, place the PTO switch in the "OFF" position, engage the brake pedal lock, turn the ignition key to the "OFF" position and remove key from switch.



#### WARNING

When handling the mower deck, be careful not to cut yourself on the sharp blades.



#### WARNING

The tractor and mower deck must be placed on a hard, level surface during installation.

1. Position the tractor and mower deck on a hard, level surface.
2. Open the tractor hood and disconnect the spark plug wire.



#### CAUTION

To avoid possible equipment damage, make sure that the tractor implement lift handle is raised to its highest setting before sliding the deck under the tractor.

4. Make sure both rear bracket slots of the deck align with both implement lift links of the tractor. (Refer to Figure 46.)

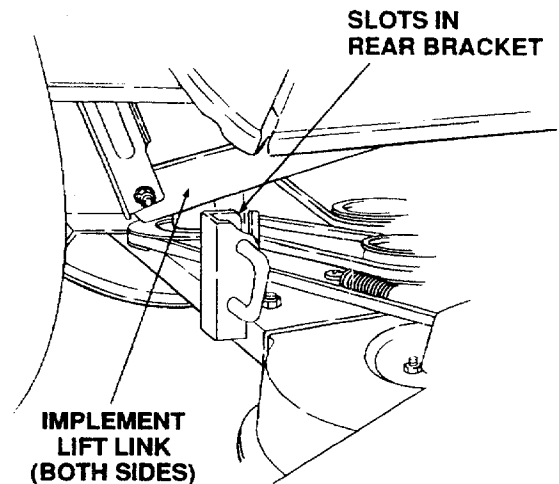

Figure 46



5. Refer to Figure 47 to determine the proper positioning of the front lift rod bracket assembly. Push downward and hold tractor quick-attach rod. Slide the left and right shoulder bolts of the front lift rod bracket assembly rearward into the left and right tractor latch receivers. Release the tractor quick-attach rod so it is held against the tractor frame by the spring, thereby securing the front lift rod bracket assembly in the tractor latch receivers. (Refer to Figure 48.)

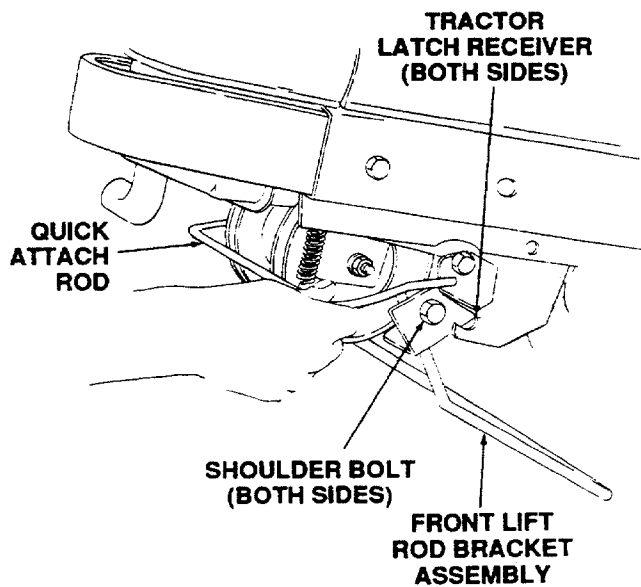

Figure 47

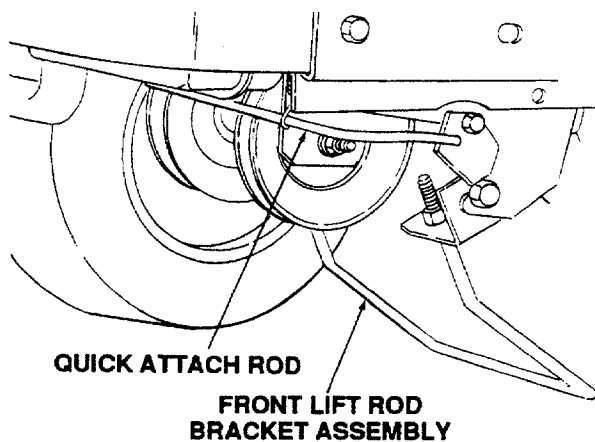

Figure 48

6. Hold the front lift rod upward and slide the mower deck forward. Lower the front lift rod so it rests to the rear of the front roller bracket slots of the deck. (Refer to Figure 49.) Slide the deck rearward in order to engage the front lift rod fully forward in the slots of the deck front roller bracket. (Refer to Figure 50.)

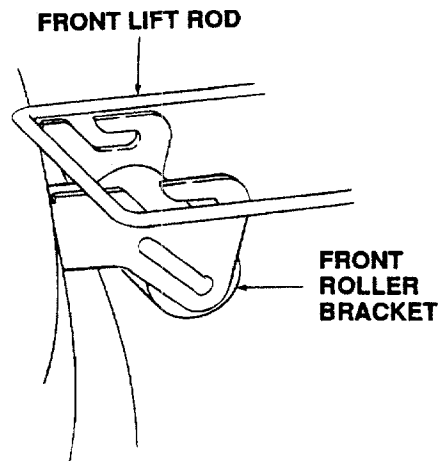

Figure 49

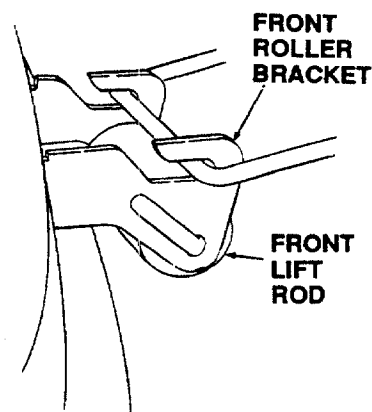

Figure 50

- If not previously accomplished, pull the deck rear bracket pins outward, turn downward and release so both spring-loaded pins are held against the outside surface of the brackets in their disengaged positions. (Refer to Figure 51.)

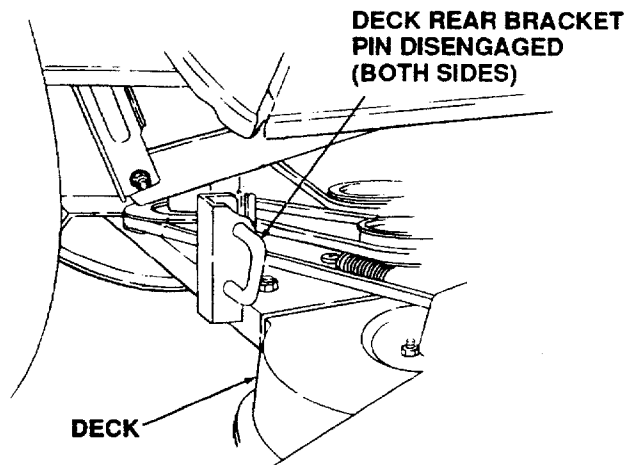

Figure 51

- Carefully engage the tractor implement lift links (left and right) into the deck rear bracket slots (left and right) as the tractor implement lift handle is lowered to its lowest setting. (Refer to Figure 52.)

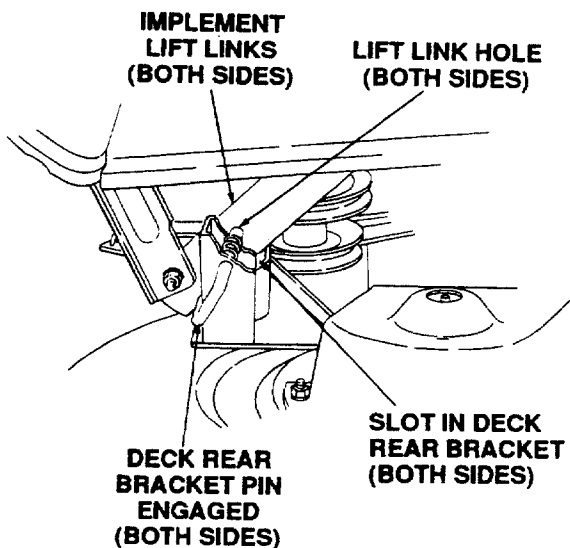

Figure 52

- Pull the deck rear bracket pins outward, turn upward so the open ends of the pins are outside the brackets and release. Adjust each pin until it passes through the hole on the inside of the bracket and the hole in the lift link. (Refer to Figure 52.)



In order to facilitate the full engagement of each pin through the hole of each lift link, lift the side of the deck slightly. While slightly raising or lowering the deck, move the lift link into position until the pin passes through the hole in the link.

- Disengage the deck idler arm lever from its stop bracket and release the spring tension until the lever is at the outside of the deck. (Refer to Figure 53.)

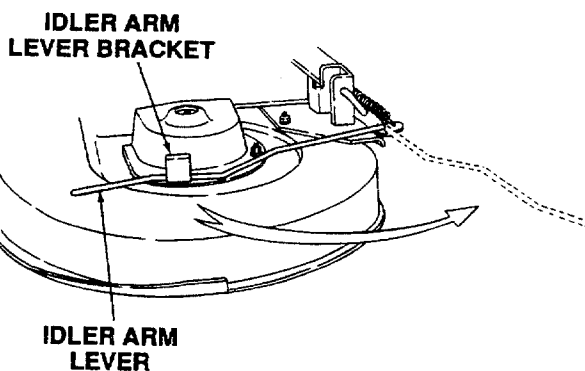

Figure 53



The exhaust system is **HOT**. To avoid personal injury, allow the engine and exhaust system to cool before proceeding with the following PTO belt installation instructions.

- Install the forward end of the PTO belt on the engine PTO clutch pulley by passing the belt upward inside the tractor frame. Ensure that the narrow side of the PTO belt engages the groove of the pulley. (Refer to Figure 54.)

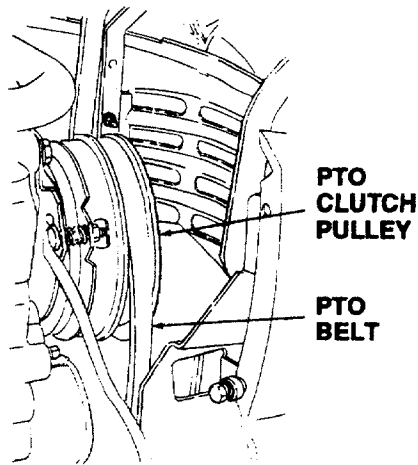

Figure 54

12. Twist the PTO belt 1/4 turn to engage the narrow sides of the belt into the grooves of the two tractor front-lower pulleys. (Refer to Figure 55.)

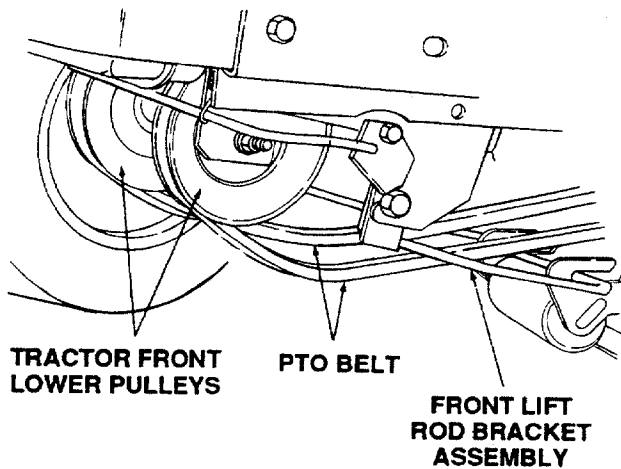

Figure 55

13. From the front of the tractor, push the PTO belt through the front lift rod, then to the center of the deck. Ensure that the forward end of the belt remains positioned inside the front lift rod.
14. Install rearward end of the PTO belt on the upper pulley of the deck center double-pulley. (Refer to Figure 56.) Ensure that narrow side of belt engages groove of the upper pulley.
15. Engage the deck idler arm lever into its stop bracket to provide tension on the PTO belt. (Refer to Figure 57.)

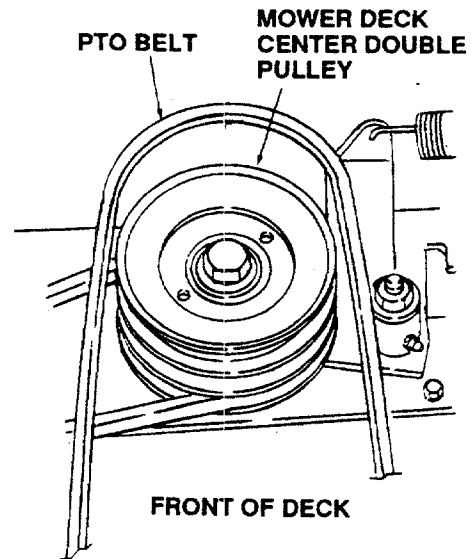

Figure 56

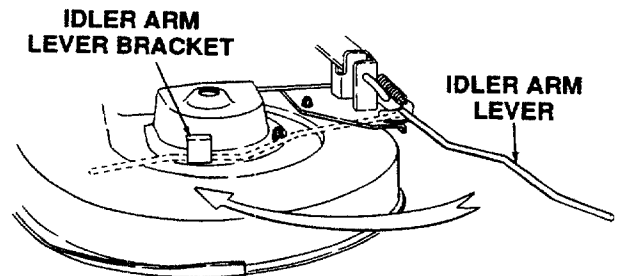

Figure 57

16. Connect the spark plug wire.

## C. MAINTENANCE

### CLEANING AND BLADE CARE



## WARNING

Before performing any maintenance, place the PTO switch in the "OFF" position, engage the brake pedal lock, turn the ignition key to the "OFF" position and remove key from switch to avoid accidental starting and injury.



## WARNING

Be careful not to cut yourself when sharpening the blades or cleaning the underside of the mower deck.

Clean the underside of the mower deck at the end of the mowing season and when buildup of cut material on the underside is noticed. Also remove the belt covers and remove any accumulation.

The cutting blades must be kept sharp at all times.



## NOTE

Sharpen ends evenly so that the blades remain balanced and the same angle of sharpness is maintained. However, if the cutting edge of a blade has been sharpened to within 3/8 inch of the wind wing, it is recommended that new blades be installed. New blades are available at your authorized dealer.

When removing the blades, hold the hex shaped pulley hub with a 1-1/4 inch socket wrench to remove the hex nut holding the blade. A block of wood may be placed between housing and cutting edge of blade to assist in removal of hex nut securing blade. (Refer to Figure 58.)

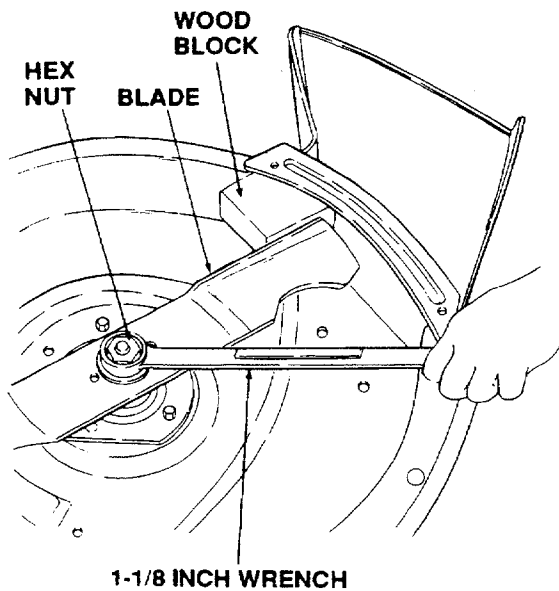

Figure 58

After replacing blades, grease the threaded end of the shaft to prevent rust buildup.

When replacing the blades, be sure they are assembled so the cutting edges are in the direction of rotation with the wind wings pointed upward. Tighten the nuts to 90 to 110 ft-lbs. (122 to 149 N·m).



## NOTE

If the spindle pulley nuts are removed for any reason, they should be retightened to 50 to 60 ft-lbs. (68 to 81 N·m) torque when replaced.

## LUBRICATION

After every 50 hours of operation and/or before putting into winter storage, lubricate the spindle assemblies and the spindle belt idler arm using 251H EP grease or equivalent No. 2 multipurpose lithium grease. The grease will be expelled from the top spindle seal. Since the spindle pulley covers the top spindle seal, the expelled grease cannot be seen. When the spindle is fully greased, the expelled grease will cause the top spindle seal to give off a muffled crackling noise. (Refer to Figure 59.)

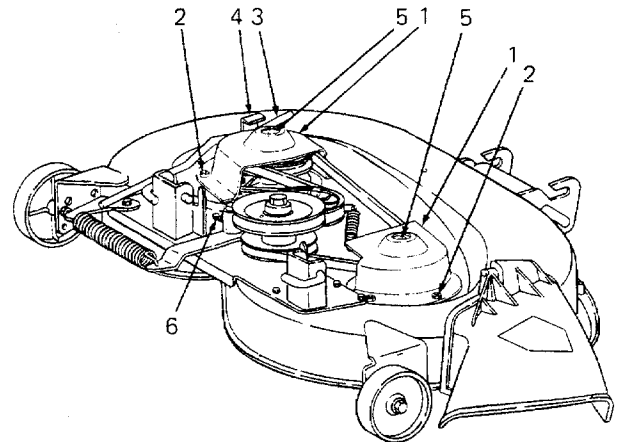

- |                       |                                     |
|-----------------------|-------------------------------------|
| 1. Spindle Belt Cover | 5. Spindle Assembly Grease Fittings |
| 2. Nuts and Washers   | 6. Idler Arm Grease Fitting         |
| 3. Idler Arm Lever    |                                     |
| 4. Stop Bracket       |                                     |

Figure 59

### SPINDLE DRIVE BELT REPLACEMENT

In order to replace the spindle drive belt, refer to Figures 59 and 60 and proceed as follows:

1. Remove the hardware that secures the spindle belt covers to the deck.
2. Remove the spindle belt covers to expose the belt.
3. Disengage the idler arm lever from its stop bracket and release spring tension until the lever is at the outside of the deck.
4. Remove old drive belt.
5. Install a new belt. Refer to Figure 60 for proper placement of belt.
6. Reinstall spindle belt covers.
7. Engage the idler arm lever into its stop bracket.

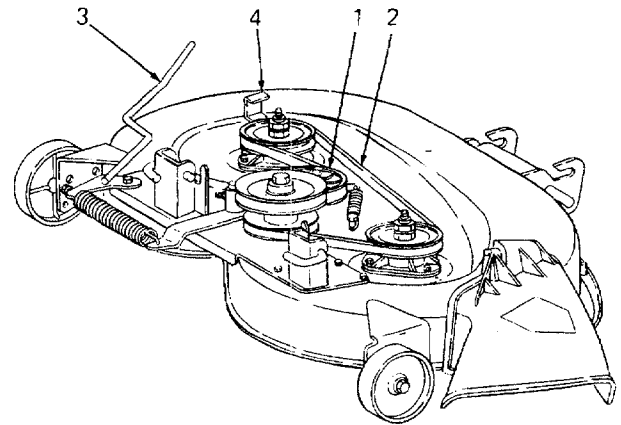

- |                       |                    |
|-----------------------|--------------------|
| 1. Idler Pulley       | 3. Idler Arm Lever |
| 2. Spindle Drive Belt | 4. Stop Bracket    |

Figure 60

## SECTION VI. OFF-SEASON STORAGE

If the machine is to be inoperative for a period longer than 30 days, the following procedures are recommended:



### WARNING

Never store engine with fuel in tank indoors or in poorly ventilated enclosures, where fuel fumes may reach an open flame, spark or pilot light as on a furnace, water heater, clothes dryer, etc.

1. Remove all gasoline from fuel tank to prevent gum deposits from forming on these parts and causing possible malfunction of engine.

Run engine until engine starts to falter, then use choke to continue engine operation until all fuel in tank and carburetor is exhausted. Remove fuel line at tank or carburetor and drain any remaining gasoline from system.



### WARNING

Drain fuel into approved container outdoors, away from open flame.

Fuel left in engine during warm weather deteriorates and will cause serious starting problems.

2. Remove spark plug and pour one (1) ounce of engine oil through spark plug hole into cylinder. Crank engine several times to distribute oil. Replace spark plug.
3. Clean the engine and the entire tractor thoroughly.
4. Lubricate all lubrication points.
5. Follow battery storage instructions on page 32.
6. Protect tires and seat from sunlight. Inflate tires at regular intervals.

## SECTION VII. MOWING

### MOWING



#### WARNING

To avoid possible injury, do not allow anyone in the area opposite the discharge chute while mowing. Although the area has been supposedly cleared of foreign objects, small objects may be discharged by the mower.



#### WARNING

Never direct discharge of material toward bystanders or allow anyone near the machine while in operation.

For best results it is recommended that the first two laps should be cut with the discharge thrown towards the center. After the first two laps, reverse the direction to throw the discharge to the outside for the balance of cutting. This will give a better appearance to the lawn.

Do not cut the grass too short, as the mower will tend to scalp the grass. Short grass invites weed growth and yellows quickly in dry weather.

Mowing should be done with the engine at full throttle. Do not mow at high ground speed.

During certain times of the year and under some conditions, the mower may leave streaks of uncut material.

Streaking may occur when attempting to mow heavy weeds and tall grass. Under these conditions it may be necessary to go back over the cut area a second time to get a clean cut.

The following practices will help eliminate streaking:

1. Mow the area more often so the grass doesn't get too tall and heavy.
2. Operate the tractor at full throttle and lower forward speeds.
3. Keep the blades sharp and replace blades when worn.
4. Follow the mowing procedure shown in Figure 61.

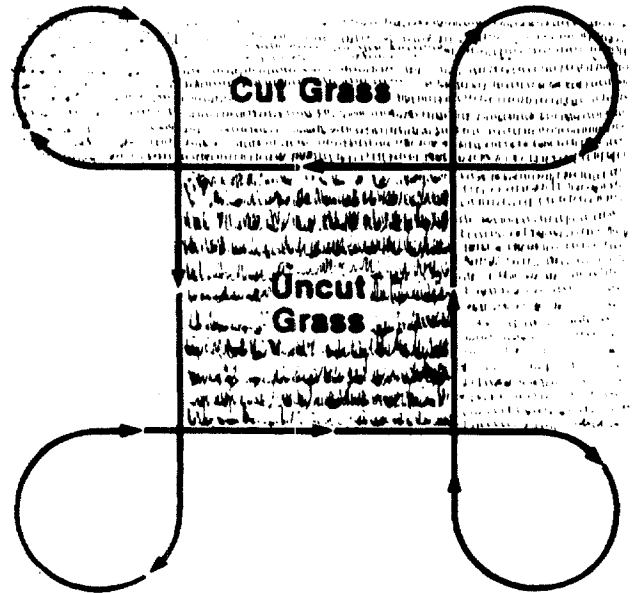

Figure 61

## OPTIONAL EQUIPMENT AND ACCESSORIES

When you purchased your tractor, you probably had it completely equipped for your particular needs at the time. However, later you may wish to obtain optional equipment or accessories. These items and other allied equipment can be purchased from, and installed by, your authorized dealer.

The tractor is used for so many different types of work, and because it is called on to operate under so many different conditions, a variety of equipment is available to adapt it to the requirements of the user. **Refer to attachment guide for a complete description of equipment and required components that can be utilized with your tractor.**



## MAINTENANCE CHART

Operation to be performed	Before each use	10 hours or once a month	30 hours three times a season	50 hours or twice a season	100 hours or yearly	Before storage
Clean grille, engine inlet air screen, dash intake screen and side panels		More often under dirty conditions X				
Check engine oil level	X					
Fill fuel tank	X					
Change engine oil & oil filter	After first 5 hours				More often under dirty conditions X	
Check transmission oil level	X					
Replace transmission oil filter (2135 only)		After first 10 hours X		After first 50 hours X	Every 100 hours there-after	
Reoil & clean foam air precleaner		X				
Check battery electrolyte level		X				
Grease front axle pivot bolt		X				
Grease steering knuckles		X				
Retorque rear wheel lug nuts		After first 10 hours X				
Clean cooling fins & external surfaces			X			
Service air cleaner paper cartridge					More often under dirty conditions	
Check spark plug					X	X
Steering gear housing			X			
Grease front wheel bearings			X			X
Drain fuel						X
Pivot bar adjustment bolts				X		
Deck spindles				X		
Spindle belt idler arm				X		
Lubricate all foot and lift control pivot points		X				

 **NOTE**

Maintenance information for operational equipment may be found in the manual which is included with the specific piece of optional equipment.

## TROUBLE SHOOTING

### Possible Cause

### Possible Remedy

#### HARD TO START

No gasoline in fuel tank or carburetor .....	Fill the tank with gasoline. Check the fuel line, carburetor and fuel filter.
Fuel line or carburetor clogged .....	Clean the fuel line and carburetor with commercial carburetor cleaner.
Fuel filter plugged .....	Replace.
Water in gasoline .....	Drain the fuel tank and carburetor. Use new fuel and dry the spark plug.
Choked improperly. Flooded engine .....	Follow the starting instructions.
Defective ignition or loose wiring .....	Check the wiring, spark plug or fuse.
Defective battery .....	Check and service. Refer to " <b>BATTERY.</b> "
Spark plug dirty or improper gap .....	Clean, adjust the gap to .040-inch or replace the plug.

#### ENGINE OPERATES IRREGULARLY OR KNOCKS

Engine incorrectly timed .....	*
Spark plug dirty; wrong gap or wrong type .....	Clean, reset the gap or replace.
Poor or weak spark .....	Check the spark plug and wiring.*
Carburetor setting incorrect .....	Adjust. Refer to " <b>ADJUSTMENTS</b> "*
Poor grade fuel or water in fuel .....	Drain and use a good grade of clean fuel.
Engine overheating .....	Refer to " <b>MAINTENANCE.</b> "
Engine valves at fault .....	*
Engine smokes .....	Adjust the carburetor.*
Oil level rises due to gasoline in crankcase .....	*
Air filter becomes oil and fuel soaked .....	*
Engine leaks oil .....	*
Misfiring .....	*
Other engine problems .....	*
Excessive oil in air cleaner .....	Be sure that oil dipstick is fully seated and all excess oil is squeezed out of pre-cleaner foam element.

#### PTO CLUTCH WILL NOT ENGAGE

Low or zero voltage .....	Check battery. Charge or replace. Check charging system. Check for worn or broken wiring or connections. Check clutch coil resistance. Check switch.
Rotor/armature air gap too large .....	Rotor/armature worn. Replace PTO clutch.

\*See your authorized dealer.

# TROUBLE SHOOTING

**Possible Cause**

**Possible Remedy**

**LACK OF POWER**

Air cleaner clogged .....	Service the air cleaner element. Refer to <b>"MAINTENANCE."</b>
Engine overload .....	Reduce the load.
Engine overheated .....	Make sure air intake screen, shrouding, engine fins, side panels, dash intake screen and grille are free of accumulated dirt and trash. Refer to <b>"MAINTENANCE."</b>
Fuel tank air vent clogged .....	Open the vent in the cap.
Air leakage between carburetor and engine .....	Remove air cleaner. Tighten the carburetor and manifold mounting nuts. Replace as indicated in <b>"MAINTENANCE."</b>
Incorrect timing or faulty ignition .....	*
Brake drags .....	Adjust the brake. Refer to <b>"ADJUSTMENTS."</b>
Insufficient cool air, dirty air intake screen, shroud, cooling fins, side panels, dash intake screen or dirty grille .....	Keep the air intake area, side panels, grille, dash intake screen and cooling fins clean; refer to <b>"MAINTENANCE."</b>
Oil level incorrect .....	Engine oil level must not be over the "FULL" mark or below the "LOW" mark. Refer to <b>"MAINTENANCE."</b>

\*See your authorized dealer.

## LUBRICATION TABLE

Point of Lubrication	Check at Hours	Change at Hours	Capacity	Anticipated Air Temperature	
				Above +32°F	Below +32°F
Engine crankcase	Check before each use	100	Approx. 4 pints	<i>Cub Cadet</i> Engine Oil SAE 10W30 or 10W40	<i>Cub Cadet</i> Engine Oil SAE 5W20 or 5W30
6-speed (Model 2130) or hydro-drive unit mounted on transmission case with filter (Model 2135)	Check before each use	Add as needed	Approx. 6 qts	<i>Cub Cadet</i> <b>NOTE:</b> <i>Cub Cadet</i> Drive System Oil is specially formulated for this application. If any other oil is used <i>Cub Cadet</i> will not be responsible for substandard performance. Failures due to use of improper fluid are not covered by warranty. For maximum protection, use <i>Cub Cadet</i> Drive System Oil.	
Steering knuckles and front axle pivot bolt	10			Use 251H EP grease or equivalent No.2 multi-purpose lithium grease and apply two strokes (minimum) or sufficient grease to flush out old grease and dirt.	
Front wheel bearings	30			Two strokes (minimum) of the lubricator using 251H EP grease or equivalent No. 2 multi-purpose lithium grease.	
Steering gear housing	30			Two strokes (minimum) of the lubricator using 251H EP grease or equivalent No. 2 multi-purpose lithium grease.	
Deck spindles	50			Two strokes (minimum) of the lubricator using 251H EP grease or equivalent No. 2 multi-purpose lithium grease.	
Spindle belt idler arm	50			Two strokes (minimum) of the lubricator using 251H EP grease or equivalent No. 2 multi-purpose lithium grease.	
Foot and lift control pivot points	10			Use a liberal amount of high grade lubricating oil.	

## LUBRICATION GUIDE



### WARNING

The life of any machine depends upon the care it is given. Proper lubrication is a very important part of that care.

Be certain that all lubrication fittings are assembled in place, using the lubrication illustrations as a guide.

Always lubricate the tractor thoroughly before taking it to the field. Use a pressure lubricating gun.

Be sure all fittings are free from dirt and paint so the lubricant is certain to enter the bearing.

Always force the lubricant through the full length of each bearing until it emerges at the end, carrying with it the worn lubricant and any dirt that may have entered the bearing.

Miscellaneous working parts not provided with lubrication fittings should be oiled daily with a good grade of lubricating oil.

Lubricant is cheap. Use plenty of it. Worn parts can be expensive to replace.

Keep your supply of lubricating oil and grease stored in clean containers, and covered to protect from dust and dirt.

Keep the lubricating gun nozzle clean and wipe dirt from grease fittings before lubricating.

The symbols in the illustration indicate the method of application and the hourly intervals to apply the lubricant.



Use a pressure lubricating gun and apply 251H EP grease (or equivalent No. 2 multi-purpose lithium grease) sufficient to flush out the old grease and dirt. Lubricate at hourly intervals indicated on symbols.



Dipstick, use to check engine oil before each use.

## LUBRICATION GUIDE

### —Before Each Use

1. Engine filler cap and dipstick
2. Transmission oil level and fill tube

Check the oil (with the engine stopped) and add sufficient new oil to bring it to the "FULL" mark on the dipstick. Do not overfill. Do not operate the engine if the oil level is below the "LOW" mark on the dipstick.

Check the oil with the engine stopped. Keep the lubricant up to "FULL" mark on dipstick.

**NOTE:** Transmission oil level and fill tube also services the following:

1. Rear axle
2. Hydrostatic transmission (Model 2135 only)
3. Clutch assembly (Model 2130 only)

### —After Every 10 Hours of Operation

3. Steering knuckles (2) (Both sides)
4. Transmission oil filter (Model 2135 only)

Use 251H EP grease or equivalent No. 2 multi-purpose lithium grease and apply sufficient grease to flush out old grease and dirt.

**NOTE:** After the first 10 hours only, remove the transmission oil filter and replace with a new filter. Refer to "MAINTENANCE." Change the transmission oil filter after 50 hours and every 100 hours of operation thereafter.

5. Front axle pivot bolt
6. Foot and lift control pivot points

Use 251H EP grease or equivalent No. 2 multi-purpose lithium grease and apply sufficient grease to flush out old grease and dirt.

Use a liberal amount of high grade lubricating oil.

### —After Every 30 Hours of Operation

7. Front wheel bearings
8. Steering gear housing (2)

Two or three strokes minimum of the lubricator using 251H EP grease or equivalent No. 2 multi-purpose lithium grease.

Every 30 hours or three times a season, use 251H EP grease or equivalent No. 2 multi-purpose lithium grease. Apply two strokes with lubricator.

### —After Every 50 Hours of Operation

9. Transmission oil filter (Model 2135 only)
10. Deck spindles
11. Spindle belt idler arm

**NOTE:** After the first 50 hours only, remove the transmission oil filter and replace with a new filter. Refer to "MAINTENANCE." Change the transmission oil filter every 100 hours of operation thereafter.

Use 251H EP grease or equivalent No. 2 multi-purpose lithium grease and apply 2 strokes (minimum) or sufficient grease to flush out old grease and dirt.

Use 251H EP grease or equivalent No. 2 multi-purpose lithium grease and apply 2 strokes (minimum) or sufficient grease to flush out old grease and dirt.

### —Every 100 Hours of Operation

12. Transmission oil filter (Model 2135 only)
13. Engine oil drain plug and oil filter

Change the transmission oil filter and replace with a new filter. Refer to "MAINTENANCE."

While the engine oil is warm, remove the drain plug and oil filter, and drain all of the oil from the crankcase. Replace the drain plug. Refer to "MAINTENANCE," "FILLING THE CRANKCASE" and "OIL FILTER" for proper oil filling procedure. Refer to "LUBRICATION TABLE" for the proper quantity and viscosity to use.

## NOTE

Lubrication information for optional equipment may be found in the manual which is included with the specific piece of optional equipment.

# LUBRICATION GUIDE

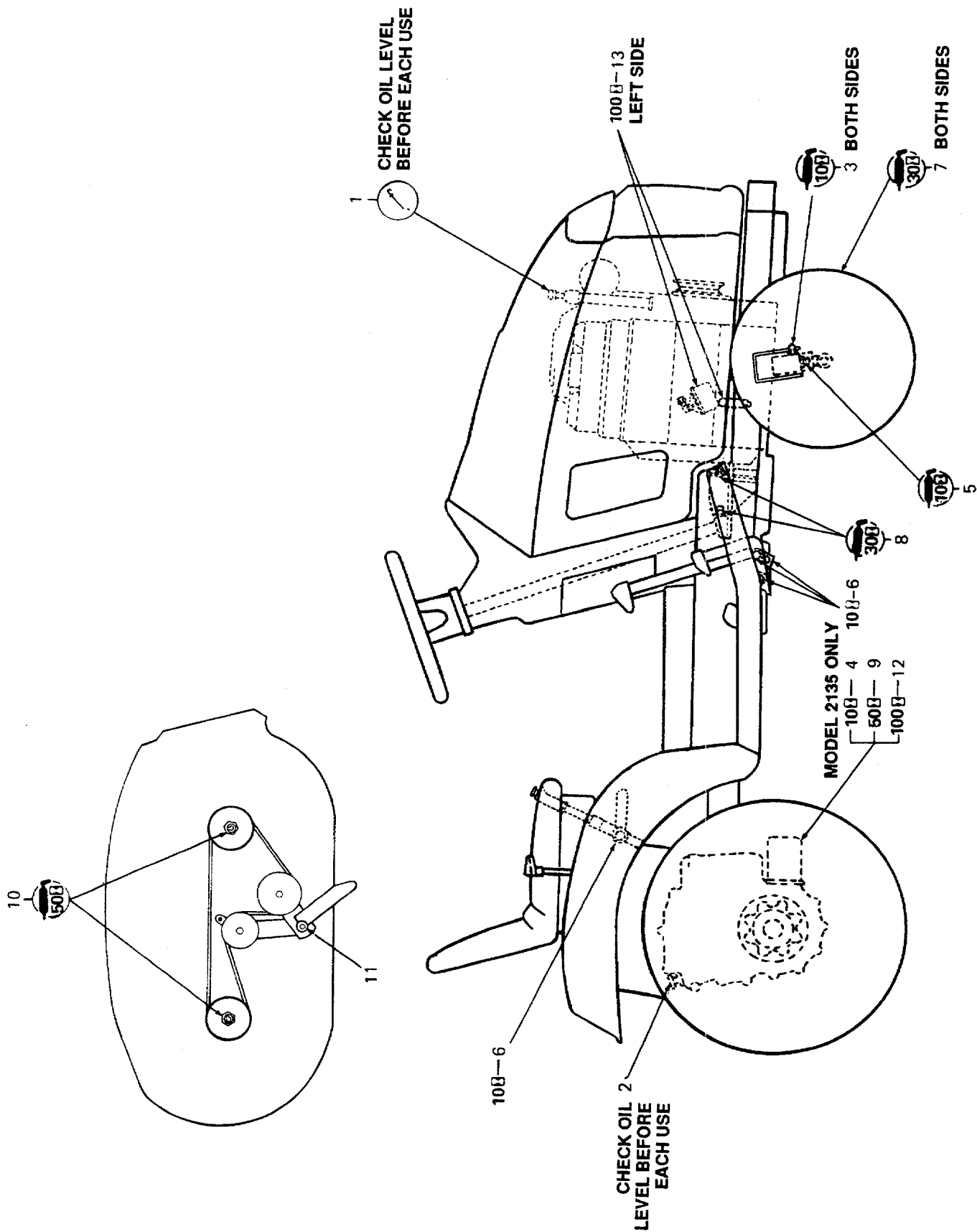

## SPECIFICATIONS

	2130	2135
<b>CAPACITIES</b>		
Fuel tank .....		3 gallons
Crankcase (approximately) .....		4 pints
Transmission case (approximately) .....		6 qts.
<b>SIX SPEED DRIVE</b>		
Speed: Forward .....	0 to 6 mph	
Reverse .....	0 to 3 mph	
<b>HYDROSTATIC DRIVE</b>		
Speed: Forward .....		0 to 5.8 mph
Reverse .....		0 to 3 mph
<b>ENGINE</b>		
Make and model .....		Kohler Command
Horsepower .....		12.5 HP
Cylinders .....		1
Bore .....		3.43 in.
Stroke .....		2.64 in.
Displacement (cubic inches) .....		24.29
Engine speed (governed)		
Low speed .....		1400 RPM
High idle speed (no load) .....		3600 RPM ±75
Ignition .....		Battery
Spark plug gap ( <i>Cub Cadet</i> No. 759-3336) .....		.040 in. gap
<b>ELECTRICAL SYSTEM</b>		
System voltage .....		12 volt neg. ground
Battery .....		725-1635
Alternator .....		15 amp regulated
Fuse (auto type) .....		20 amp
Head lamp bulb .....		759-3693
<b>BRAKES</b> .....		Internal expanding
<b>TIRE SIZES</b>		
Front .....		15 x 6-6
Rear .....		20 x 9-8
<b>DIMENSIONS</b>		
Tread:		
Front with 15 x 6-6 tires .....		30.00 in.
Rear with 20 x 9-8 tires .....		27.50 in.
Wheelbase .....		47.00 in.
Length, over-all .....		72.00 in.
Width, over-all (chute up) .....		45.00 in.
Height, over-all (to top of steering wheel) .....		42.00 in.
Ground clearance .....		6.00 in.
Turning radius .....		24.00 in.

**Specifications are subject to change without notice.**



USE THIS SHEET AS A GUIDE TO DETERMINE SLOPES WHERE YOU MAY NOT OPERATE SAFELY.

# SLOPE GAUGE

(Keep this sheet in a safe place for future reference.)

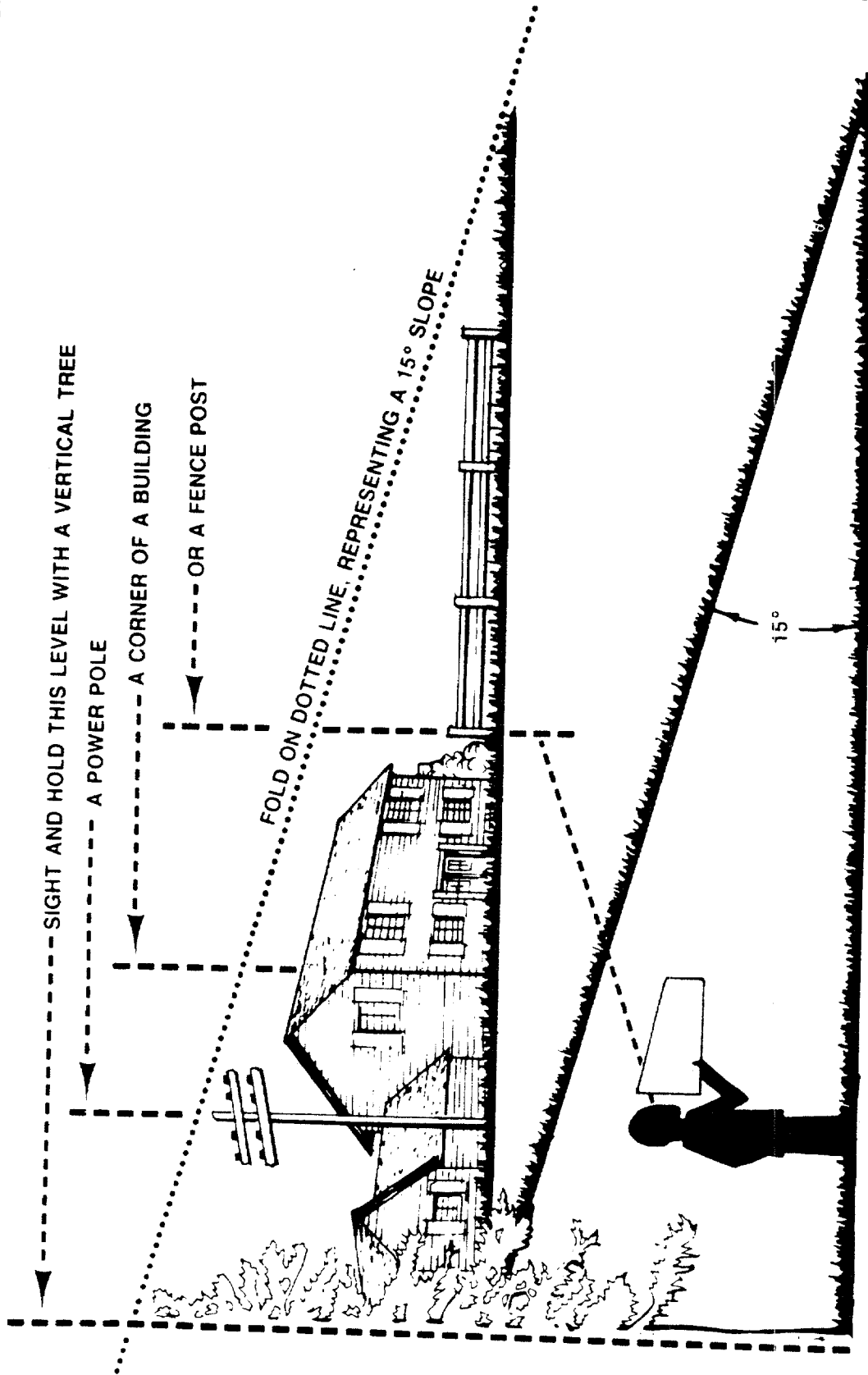







Do not mow on inclines with a slope in excess of 15 degrees (a rise of approximately 2½ feet every 10 feet). A riding mower could overturn and cause serious injury. If operating a walk-behind mower on such a slope, it is extremely difficult to maintain your footing and you could slip, resulting in serious injury.

Operate RIDING mowers up and down slopes, never across the face of slopes.

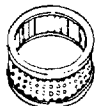
Operate WALK-BEHIND mowers across the face of slopes, never up and down slopes.

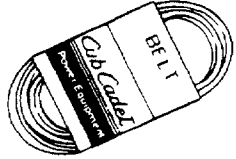
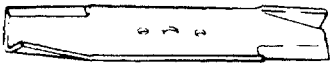

## MAINTENANCE PARTS CHART

MODELS 2130 AND 2135		SERIES 2000 12.5 HP KOHLER			
<b>ENGINE OIL</b> 	<b>Engine Oil Requirements approx. . . 4 pints</b> Cub Cadet engine oil Ambient temperature viscosity (Grade SF or SG) Above +32°F                    SAE 10W30 or 10W40 Below +32°F                    SAE 5W20 or 5W30			<b>Part No.</b>  737-3030A (10W30) 737-3049 (5W30)	
<b>AIR FILTER</b>  <b>CARTRIDGE</b>   <b>FOAM PRE-CLEANER</b>	<b>Air Filter Requirements</b> Clean air filter per instructions in your owner's manual . . . . . under maintenance air cleaner.			<b>Part No.</b>  Cartridge 759-3547  Foam Pre-cleaner KH-52-083-01	
<b>ENGINE OIL FILTER</b> 	<b>Engine Oil Filter Requirements</b> Change every 100 hours			<b>Part No.</b>  KH-12-050-08	
<b>SPARK PLUG</b> 	<b>Gap Requirements</b> .040 inch gap			<b>Part No.</b>  759-3336	
<b>TRANSMISSION OIL FILTER</b> 	<b>Oil Filter Requirements (2135 only)</b> Change every 100 hours			<b>Part No.</b>  723-3014	
<b>TRANSMISSION OIL</b> 	<b>Transmission Oil Requirements approx. . . 6 qts</b> Check before each use <div style="text-align: center;">1 quart</div>			<b>Part No.</b>  737-3055	
<b>BELTS</b> 	<b>Deck Blade Belt</b>		<b>Tractor to Deck Belt</b>		
	<b>Model</b>	<b>Part No.</b>	<b>Model</b>	<b>Part No.</b>	
	38" Deck	754-3029	38" Deck	754-3055A	
<b>BLADES</b> 	<b>Original Equipment Blade</b>		<b>Hard Coated Blade</b>		
	<b>Size</b>	<b>Part No.</b>	<b>Size</b>	<b>Part No.</b>	
	38"	742-3009 (2)	38"	759-3395 (2)	
	<b>Bagging Blade</b>		<b>Hard Coated Bagging Blade</b>		
	<b>Size</b>	<b>Part No.</b>	<b>Size</b>	<b>Part No.</b>	
	38"	742-3008 (2)	38"	759-3396 (2)	

