



Dell Studio™ 540 Service Manual

[Technical Overview](#)
[Before You Begin](#)
[Replacing the Computer Cover](#)
[Replacing the Front Panel](#)
[Replacing Memory Module\(s\)](#)
[Replacing a PCI/PCI Express Card](#)
[Replacing Drives](#)
[Replacing Fans](#)

[Replacing the Front I/O Panel](#)
[Replacing the Processor](#)
[Replacing the System Board](#)
[Replacing the Power Supply](#)
[Replacing the Battery](#)
[Replacing the Rubber Foot](#)
[System Setup](#)

Notes, Notices, and Cautions

-  **NOTE:** A NOTE indicates important information that helps you make better use of your computer.
 -  **NOTICE:** A NOTICE indicates either potential damage to hardware or loss of data and tells you how to avoid the problem.
 -  **CAUTION:** A CAUTION indicates a potential for property damage, personal injury, or death.
-

Information in this document is subject to change without notice.
© 2008 Dell Inc. All rights reserved.

Reproduction of these materials in any manner whatsoever without the written permission of Dell Inc. is strictly forbidden.

Trademarks used in this text: *Dell*, the *DELL* logo, and *Dell Studio* are trademarks of Dell Inc.; *Microsoft* and *Windows* are either trademarks or registered trademarks of Microsoft Corporation in the United States and/or other countries.

Other trademarks and trade names may be used in this document to refer to either the entities claiming the marks and names or their products. Dell Inc. disclaims any proprietary interest in trademarks and trade names other than its own.

Model: DCMA

July 2008 Rev. A00

[Back to Contents Page](#)

Before You Begin

Dell Studio™ 540 Service Manual

- [Technical Specifications](#)
- [Recommended Tools](#)
- [Turning Off Your Computer](#)
- [Safety Instructions](#)

This chapter provides procedures for removing and installing the components in your computer. Unless otherwise noted, each procedure assumes that the following conditions exist:

- 1 You have performed the steps in [Turning Off Your Computer](#) and [Safety Instructions](#).
 - 1 You have read the safety information that shipped with your computer.
 - 1 A component can be replaced or—if purchased separately—installed by performing the removal procedure in reverse order.
-

Technical Specifications

For information on technical specifications of your computer, see the *Setup Guide* that shipped with your computer or see the Dell Support website at support.dell.com.

Recommended Tools

The procedures in this document may require the use of a small Phillips screwdriver size #2.

Turning Off Your Computer

➡ **NOTICE:** To avoid losing data, save and close all open files and exit all open programs before you turn off your computer.

1. Shut down the operating system.
 2. Ensure that the computer and all attached devices are turned off. If your computer and attached devices did not automatically turn off when you shut down your operating system, press and hold the power button for about 4 seconds to turn them off.
-

Safety Instructions

Use the following safety guidelines to help protect your computer from potential damage and to help to ensure your own personal safety.

⚠ **CAUTION:** Before working inside your computer, read the safety information that shipped with your computer. For additional safety best practices information, see the [Regulatory Compliance Homepage](http://www.dell.com/regulatory_compliance) at www.dell.com/regulatory_compliance.

➡ **NOTICE:** Only a certified service technician should perform repairs on your computer. Damage due to servicing that is not authorized by Dell™ is not covered by your warranty.

➡ **NOTICE:** When you disconnect a cable, pull on its connector or on its pull-tab, not on the cable itself. Some cables have connectors with locking tabs: if you are disconnecting this type of cable, press in on the locking tabs before you disconnect the cable. As you pull connectors apart, keep them evenly aligned to avoid bending any connector pins. Also, before you connect a cable, ensure that both connectors are correctly oriented and aligned.

➡ **NOTICE:** To avoid damaging the computer, perform the following steps before you begin working inside the computer.

1. Ensure that the work surface is flat and clean to prevent the computer cover from being scratched.
2. Turn off your computer (see [Turning Off Your Computer](#)).

➡ **NOTICE:** To disconnect a network cable, first unplug the cable from your computer and then unplug the cable from the network device.

3. Disconnect all telephone or network cables from the computer.
4. Disconnect your computer and all attached devices from their electrical outlets.
5. Press and hold the power button while the system is unplugged to ground the system board.

 **NOTICE:** Before touching anything inside your computer, ground yourself by touching an unpainted metal surface, such as the metal at the back of the computer. While you work, periodically touch an unpainted metal surface to dissipate static electricity, which could harm internal components.

[Back to Contents Page](#)

Replacing a PCI/PCI Express Card

Dell Studio™ 540 Service Manual

- [Removing a PCI/PCI Express Card](#)
- [Installing a PCI/PCI Express Card](#)
- [Replacing the Card Retention Bracket](#)
- [Configuring Your Computer After Removing or Installing a PCI/PCI Express Card](#)

⚠ CAUTION: Before working inside your computer, read the safety information that shipped with your computer. For additional safety best practices information, see the Regulatory Compliance Homepage at www.dell.com/regulatory_compliance.

Removing a PCI/PCI Express Card

1. Uninstall the card's driver and software from the operating system. For more information, see the *Setup Guide*.
2. Follow the procedures in [Before You Begin](#).
3. Remove the computer cover (see [Replacing the Computer Cover](#)).
4. Remove the screw holding the card retention bracket.
5. Lift the card retention bracket and set it aside in a secure place.

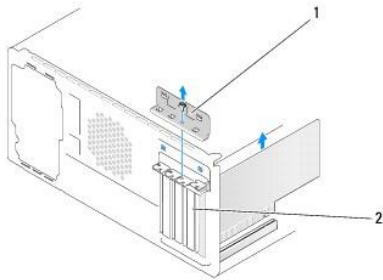

1	card retention bracket	2	filler bracket
---	------------------------	---	----------------

6. If necessary, disconnect any cables connected to the card.
 - 1 For a PCI card, grasp the card by its top corners, and ease it out of its connector.
 - 1 For a PCI Express card, pull the securing tab, grasp the card by its top corners, and then ease it out of its connector.
 7. If you are replacing an existing card, go to [step 6](#) of [Installing a PCI/PCI Express Card](#).
 - **NOTICE:** Installing filler brackets over empty card-slot openings is necessary to maintain FCC certification of the computer. The brackets also keep dust and dirt out of your computer.
 8. Install a filler bracket in the empty card-slot opening.
 9. Replace the card retention bracket. See [Replacing the Card Retention Bracket](#).
 10. Replace the computer cover, reconnect the computer and devices to electrical outlets, and then turn them on.
 11. To complete the removal procedure, see [Configuring Your Computer After Removing or Installing a PCI/PCI Express Card](#).
-

Installing a PCI/PCI Express Card

1. Follow the procedures in [Before You Begin](#).
2. Remove the computer cover. See [Replacing the Computer Cover](#).

3. Remove the screw holding the card retention bracket.
4. Lift the card retention bracket and set it aside in a secure place.
5. Remove the filler bracket to create a card-slot opening.
6. Prepare the card for installation.

See the documentation that came with the card for information on configuring, customizing and making internal connections on the card.

7. Align the card with the connector.

NOTE: If you are installing a PCI Express card into the x16 connector, ensure that the securing slot is aligned with the securing tab.

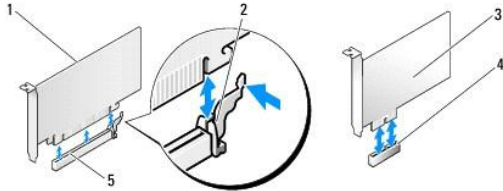

1	PCI Express x16 card	2	securing tab
3	PCI Express x1 card	4	PCI Express x1 card slot
5	PCI Express x16 card slot		

8. Place the card in the connector and press down firmly. Ensure that the card is fully seated in the slot.

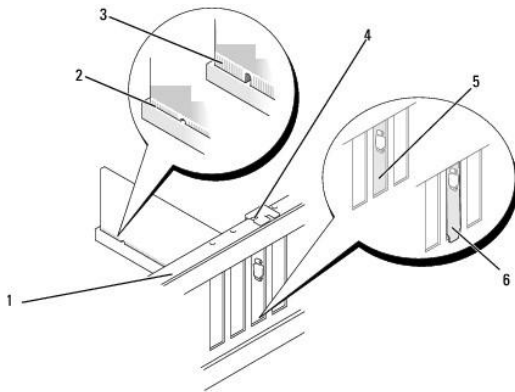

1	alignment bar	2	fully-seated card
3	not fully-seated card	4	alignment guide
5	bracket within slot	6	bracket caught outside of slot

9. Replace the card retention bracket. See [Replacing the Card Retention Bracket](#).

NOTICE: Do not route card cables over or behind the cards. Cables routed over the cards can prevent the computer cover from closing properly or cause damage to the equipment.

10. Connect any cables that should be attached to the card.

See the documentation for the card for information about the card's cable connections.

11. Replace the computer cover, reconnect the computer and devices to electrical outlets, and then turn them on.

12. To complete the installation, see [Configuring Your Computer After Removing or Installing a PCI/PCI Express Card](#).

Replacing the Card Retention Bracket

Replace the card retention bracket ensuring that:

- 1 The guide clamp is aligned with the guide notch.
- 1 The tops of all cards and filler brackets are flush with the alignment bar.
- 1 The notch in the top of the card or filler bracket fits around the alignment guide.

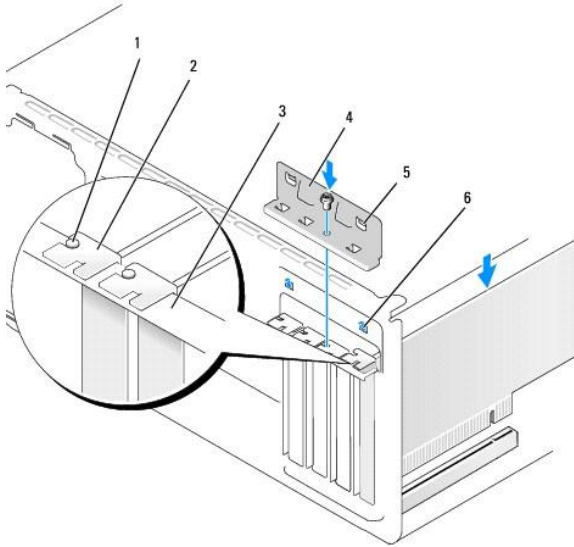

1	alignment guide	2	filler bracket
3	alignment bar	4	card retention bracket
5	guide clamps (2)	6	guide notchs (2)

Configuring Your Computer After Removing or Installing a PCI /PCI Express Card

NOTE: For information on location of connectors, see the *Setup Guide*. For information on installing drivers and software for your card, see the documentation that shipped with the card.

	Installed	Removed
Sound Card	<ol style="list-style-type: none"> 1. Enter system setup (see System Setup). 2. Go to Integrated Peripherals and select Onboard Audio Controller, and then change the setting to Disabled. 3. Connect the external audio devices to the sound card's connectors. 	<ol style="list-style-type: none"> 1. Enter system setup (see System Setup). 2. Go to Integrated Peripherals and select Onboard change the setting to Enabled. 3. Connect the external audio devices to the comput
Network Card	<ol style="list-style-type: none"> 1. Enter system setup (see System Setup). 2. Go to Integrated Peripherals and select Onboard LAN Controller, and then change the setting to Disabled. 3. Connect the network cable to the network card's connector. 	<ol style="list-style-type: none"> 1. Enter system setup (see System Setup). 2. Go to Integrated Peripherals and select Onboard change the setting to Enabled. 3. Connect the network cable to the integrated netw

[Back to Contents Page](#)

Replacing the Battery

Dell Studio™ 540 Service Manual

CAUTION: Before working inside your computer, read the safety information that shipped with your computer. For additional safety best practices information, see the Regulatory Compliance Homepage at www.dell.com/regulatory_compliance.

CAUTION: A new battery can explode if it is incorrectly installed. Replace the battery only with the same or equivalent type recommended by the manufacturer. Discard used batteries according to the manufacturer's instructions.

1. Record all the screens in system setup (see [System Setup](#)) so that you can restore the correct settings in [step 10](#).
2. Follow the procedures in [Before You Begin](#).
3. Remove the computer cover (see [Replacing the Computer Cover](#)).
4. Locate the battery socket (see [System Board Components](#)).

NOTICE: If you pry the battery out of its socket with a blunt object, be careful not to touch the system board with the object. Ensure that the object is inserted between the battery and the socket before you attempt to pry out the battery. Otherwise, you may damage the system board by prying off the socket or by breaking circuit traces on the system board.

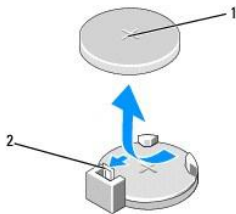

1	battery (positive side)	2	battery release lever
---	-------------------------	---	-----------------------

5. Carefully press the battery release lever away from the battery and the battery will pop out.
6. Remove the battery from the system and properly dispose of the battery.
7. Insert the new battery into the socket with the side labeled "+" facing up, then snap the battery into place.

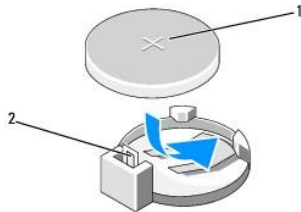

1	battery (positive side)	2	battery release lever
---	-------------------------	---	-----------------------

8. Replace the computer cover (see [Replacing the Computer Cover](#)).
9. Connect your computer and devices to electrical outlets, and then turn them on.
10. Enter system setup (see [System Setup](#)) and restore the settings you recorded in [step 1](#).

Replacing the Computer Cover

Dell Studio™ 540 Service Manual

- ⚠ CAUTION:** Before working inside your computer, read the safety information that shipped with your computer. For additional safety best practices information, see the Regulatory Compliance Homepage at www.dell.com/regulatory_compliance.
- ⚠ CAUTION:** To guard against likelihood of electric shock, laceration by moving fan blades or other unexpected injuries, always unplug your computer from the electrical outlet before removing the cover.
- 🔍 NOTICE:** Ensure that sufficient space exists to support the system with the cover removed—at least 30 cm (1 ft.) of desk top space.

1. Follow the procedures in [Before You Begin](#).
2. Lay your computer on its side with the computer cover facing up.
3. Open the padlock, if applicable.
4. Remove the two thumbscrews.

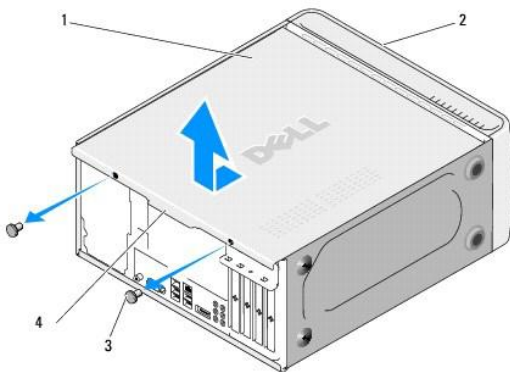

1	computer cover	2	front of computer
3	thumbscrews (2)	4	cover grip

5. Pull the cover grip towards the back of the computer lift it away from the computer.
6. Set the cover aside in a secure location.
7. To replace the computer cover, perform the removal procedure in reverse order.

Replacing the Processor

Dell Studio™ 540 Service Manual

CAUTION: Before working inside your computer, read the safety information that shipped with your computer. For additional safety best practices information, see the Regulatory Compliance Homepage at www.dell.com/regulatory_compliance.

NOTICE: Do not perform the following steps unless you are familiar with hardware removal and replacement. Performing these steps incorrectly could damage your system board. For technical service, see the *Setup Guide*.

1. Follow the procedures in [Before You Begin](#).
2. Remove the computer cover (see [Replacing the Computer Cover](#)).

CAUTION: Despite having a plastic shield, the heat sink assembly may be very hot during normal operation. Be sure that it has had sufficient time to cool before you touch it.

3. Disconnect the power cables from the ATX POWER and ATX_CPU connectors (see [System Board Components](#)) on the system board.
4. Remove the processor fan and heat sink assembly from the computer (see [Replacing the Processor Fan and Heat Sink Assembly](#)).

NOTE: Unless a new heat sink is required for the new processor, reuse the original heat sink assembly when you replace the processor.

5. Press and push the release lever down and out to release it from the tab that secures it.
6. Open the processor cover.

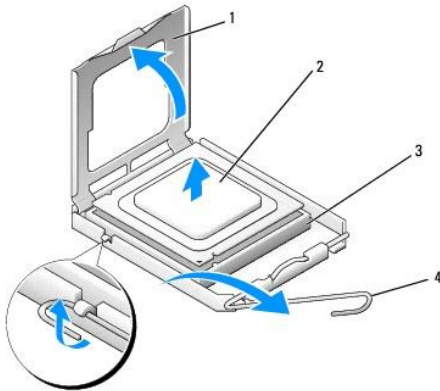

1	processor cover	2	processor
3	socket	4	release lever

7. Lift up the processor to remove it from the socket, place it aside in a safe and secure place.

Leave the release lever extended in the release position so that the socket is ready for the new processor.

NOTICE: When removing or replacing the processor, do not touch any of the pins inside the socket or allow any objects to fall on the pins in the socket.

NOTICE: Ground yourself by touching an unpainted metal surface on the back of the computer.

8. Unpack the new processor, be careful not to touch the underside of the processor.

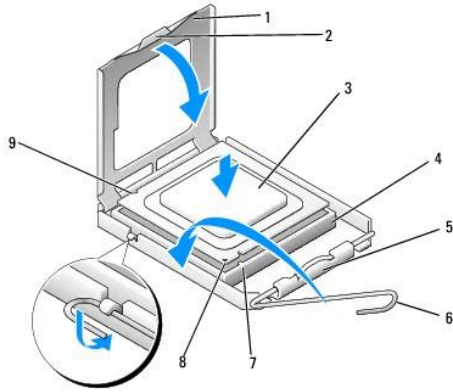

1	processor cover	2	tab
3	processor	4	socket
5	center cover latch	6	release lever
7	front alignment-notch	8	processor pin-1 indicator
9	back alignment notch		

9. If the release lever on the socket is not fully extended, move it to that position.

➡ **NOTICE:** You must position the processor correctly in the socket to avoid permanent damage to the processor and the computer when you turn on the computer.

➡ **NOTICE:** Socket pins are delicate. To avoid damage, ensure that the processor is aligned properly with the socket, and do not use excessive force when you replace the processor. Be careful not to touch or bend the pins on the system board.

10. Orient the front and back alignment-notches on the processor with the front and back alignment-notches on the socket.

11. Align the pin-1 corners of the processor and socket.

➡ **NOTICE:** To avoid damage, ensure that the processor aligns properly with the socket, and do not use excessive force when you install the processor.

12. Set the processor lightly in the socket and ensure that the processor is positioned correctly.

13. When the processor is fully seated in the socket, close the processor cover.

📌 **NOTE:** Ensure that the tab on the processor cover is positioned underneath the center cover latch on the socket.

14. Pivot the socket release lever back towards the socket, and snap it into place to secure the processor.

15. Clean the thermal grease from the bottom of the heat sink.

➡ **NOTICE:** Ensure that you apply new thermal grease. New thermal grease is critical for ensuring adequate thermal bonding, which is a requirement for optimal processor operation.

16. Apply the new thermal grease to the top of the processor.

17. Replace the processor fan and heat sink assembly (see [Replacing the Processor Fan and Heat Sink Assembly](#)).

➡ **NOTICE:** Ensure that the processor fan and heat sink assembly is correctly seated and secure.

18. Connect the power cables from the ATX POWER and ATX_CPU connectors (see [System Board Components](#)) on the system board.

19. Replace the computer cover (see [Replacing the Computer Cover](#)).

20. Connect your computer and devices to electrical outlets, and then turn them on.

[Back to Contents Page](#)

Replacing Drives

Dell Studio™ 540 Service Manual

- [Replacing a Hard Drive](#)
- [Replacing a CD/DVD Drive](#)
- [Replacing the FlexDock](#)
- [Removing the FlexDock Break-Away Metal Plate](#)
- [Replacing the FlexDock Drive Inserts](#)
- [Replacing the Drive Panel Insert](#)
- [Replacing the Media Card Reader](#)

⚠ CAUTION: Before working inside your computer, read the safety information that shipped with your computer. For additional safety best practices information, see the [Regulatory Compliance Homepage](http://www.dell.com/regulatory_compliance) at www.dell.com/regulatory_compliance.

🔍 NOTE: The system does not support IDE devices.

🔍 NOTE: The 3.5-inch FlexDock is not interchangeable with the hard drive carrier.

Replacing a Hard Drive

➡ **NOTICE:** If you are replacing a hard drive that contains data you want to keep, back up your files before you begin this procedure.

1. Follow the procedures in [Before You Begin](#).
2. Remove the computer cover (see [Replacing the Computer Cover](#)).
3. Disconnect the power and data cables from the hard drive.

🔍 NOTE: If you are not replacing the hard drive at this time, disconnect the other end of the data cable from the system board and set it aside. You can use the data cable to install a hard drive at a later time.

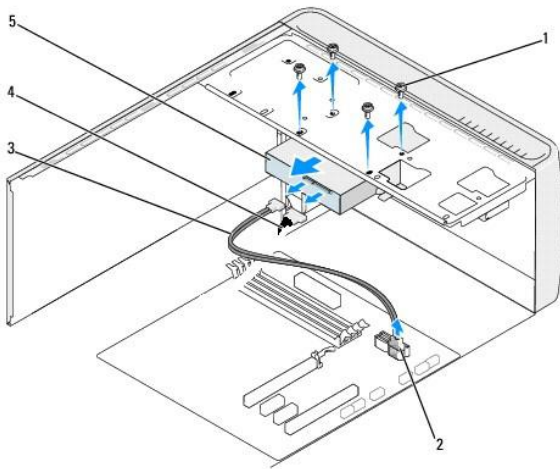

1	screws (4)	2	system board connector (any available connector SATA0, SATA1, SATA4, and SATA5)
3	serial ATA data cable	4	power cable
5	hard drive		

4. Remove the four screws securing the hard drive to the chassis.

➡ **NOTICE:** Ensure that you do not scratch the hard disk circuit board, while removing or replacing the hard drive.

5. Slide the drive out towards the back of the computer.

6. To replace the hard drive, check the documentation for the drive to verify that it is configured for your computer.
7. Slide the hard drive into the hard drive bay.
8. Align the four screw holes in the hard drive with the screw holes in the hard drive bay.
9. Replace the four screws that secure the hard drive to the chassis.
10. Connect the power and data cables to the hard drive.
11. Ensure that all the cables are properly connected and firmly seated.
12. Replace the computer cover (see [Replacing the Computer Cover](#)).
13. Connect your computer and devices to electrical outlets, and then turn them on.

Replacing a CD/DVD Drive

1. Follow the procedures in [Before You Begin](#).
2. Remove the computer cover (see [Replacing the Computer Cover](#)).
3. Remove the front panel (see [Replacing the Front Panel](#)).

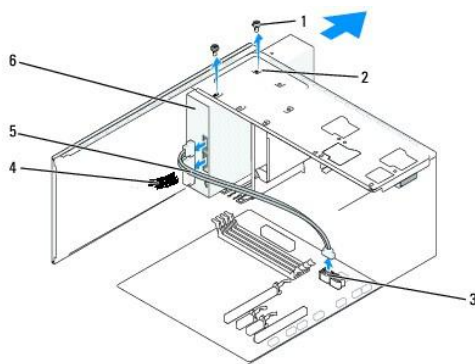

1	custom screws (2)	2	screw holes in the CD/DVD drive bay	3	system board connector (any available connector SATA0, SATA1, SATA4, and SATA5)
4	power cable	5	data cable	6	CD/DVD drive

4. Disconnect the power cable and the data cable from the back of the CD/DVD drive.

 **NOTE:** If you are uninstalling the only CD/DVD drive in your computer and will not replace it at this time, disconnect the data cable from the system board and set it aside.

5. Remove the two screws securing the CD/DVD drive to the chassis.
6. Push and slide the CD/DVD drive out through the front of the computer.
7. If you are not replacing the drive:
 - a. Replace the drive panel insert (see [Replacing the Drive Panel Insert](#)).
 - b. Go to [step 12](#).
8. If you are replacing the CD/DVD drive or installing a new one, slide the drive into place.
9. Align the screw holes in the CD/DVD drive with the screw holes in the CD/DVD drive bay.
10. Replace the two screws securing the CD/DVD drive to the chassis.
11. Connect the power and data cables to the CD/DVD drive.

12. Replace the front panel (see [Replacing the Front Panel](#)).
13. Replace the computer cover (see [Replacing the Computer Cover](#)).
14. Connect your computer and devices to their electrical outlets, and turn them on.

 **NOTE:** If you installed a new drive, see the documentation that came with the drive for instructions on installing any software required for drive operation.

Replacing the FlexDock

1. Follow the procedures in [Before You Begin](#).
2. Remove the computer cover (see [Replacing the Computer Cover](#)).
3. Remove the front panel (see [Replacing the Front Panel](#)).

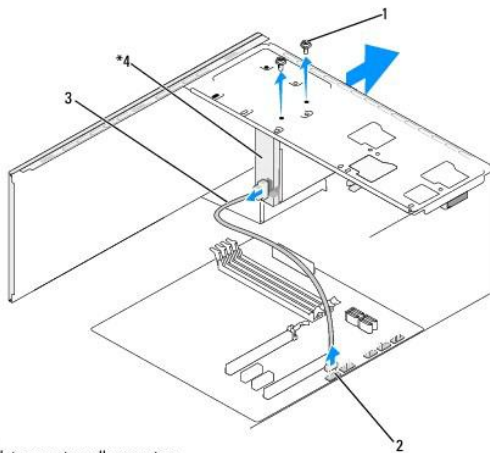

*Not present on all computers.

1	custom screws (2)	2	F_USB1 connector
3	FlexDock USB cable	4	FlexDock

4. Disconnect the FlexDock USB cable from the back of the FlexDock and from the internal USB connector (F_USB1) on the system board (see [System Board Components](#)).
5. Remove the two screws securing the FlexDock.
6. Slide the FlexDock out through the front of the computer.
7. If you are not replacing the FlexDock, replace the drive panel insert (see [Replacing the Drive Panel Insert](#)).
8. If you are installing a new FlexDock:
 - a. Remove the drive panel insert, if applicable (see [Replacing the Drive Panel Insert](#)).
 - b. Remove the FlexDock from its packaging.
9. Gently slide the FlexDock into place in the FlexDock slot.
10. Align the screw holes in the FlexDock with the screw holes in the FlexDock.
11. Replace the two screws that secure the FlexDock.

 **NOTE:** Ensure that the FlexDock is installed before the FlexDock cable is connected.
12. Connect the FlexDock USB cable to the back of the FlexDock and to the internal USB connector (F_USB1) on the system board (see [System Board Components](#)).

13. Replace the front panel (see [Replacing the Front Panel](#)).
14. Replace the computer cover (see [Replacing the Computer Cover](#)).
15. Connect your computer and devices to electrical outlets, and then turn them on.

Removing the FlexDock Break-Away Metal Plate

Align the tip of a Phillips screwdriver with the slot on the break-away metal plate and rotate the screwdriver outwards to break and remove the metal plate.

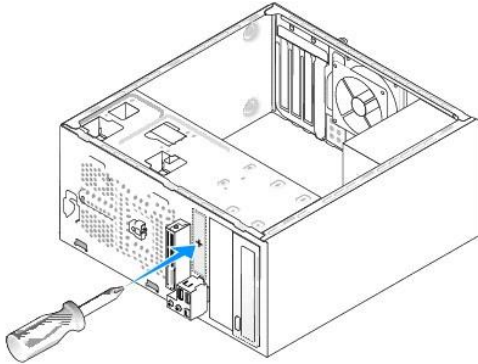

Replacing the FlexDock Drive Inserts

NOTICE: To comply with FCC regulations, it is recommended that you replace the FlexDock drive insert whenever the FlexDock drive is removed from the computer.

1. Remove the front panel (see [Replacing the Front I/O Panel](#)).
2. Gently press on the insert lever outward to release the lock.
3. Pull the FlexDock drive insert away from the front panel.
4. To replace the FlexDock drive insert, align the FlexDock drive insert in place.
5. Push the insert lever towards the front panel till it snaps in place.

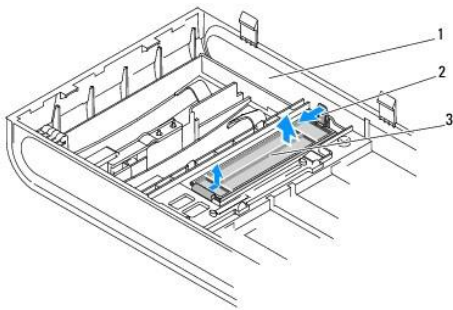

1	front panel	2	insert lever
3	FlexDock drive insert		

Replacing the Drive Panel Insert

Align the drive panel insert along the edges of the empty slot of the FlexDock or CD/DVD drive and push the panel insert and push the panel insert until it locks in place.

➡ **NOTICE:** To comply with FCC regulations, it is recommended that you replace the drive panel insert whenever the FlexDock is removed from the computer.

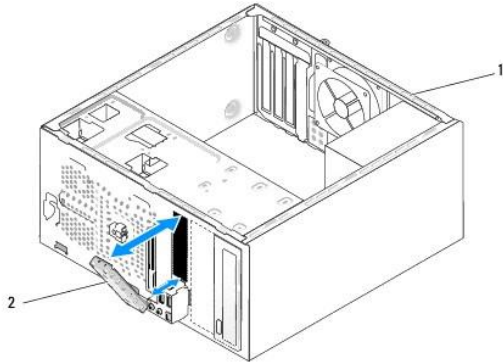

1	back of the computer	2	drive panel insert (optional)
---	----------------------	---	-------------------------------

Replacing the Media Card Reader

1. Follow the procedures in [Before You Begin](#).
2. Remove the computer cover (see [Replacing the Computer Cover](#)).
3. Remove the front panel (see [Replacing the Front Panel](#)).
4. Remove any expansion cards (see [Replacing a PCI/PCI Express Card](#)).

➡ **NOTICE:** Carefully note the routing of each cable before you disconnect it, so that you are sure to re-route cables correctly. An incorrectly routed or a disconnected cable could lead to computer problems.

5. Disconnect the cable that is connected to the mediocard reader from the system board (F_USB4).
6. Remove the screw that secures the Media Card Reader to the chassis.
7. Carefully remove the existing Media Card Reader from the computer.

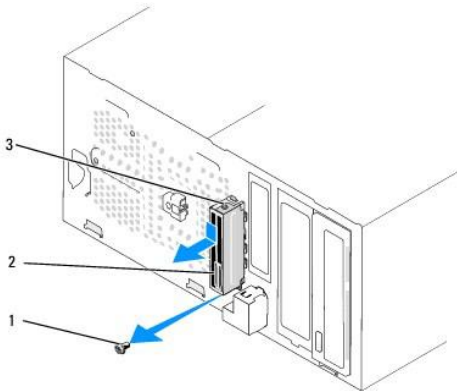

1	screw	2	Media Card Reader
3	Media Card Reader clamp		

8. To install a new Media Card Reader, align and slide the Media Card Reader clamp into the Media Card Reader clamp slot.
9. Replace and tighten the screw that secures the Media Card Reader to the chassis.
10. Reconnect the cables to the system board.

11. Replace any expansion cards (see [Replacing a PCI/PCI Express Card](#)).
 12. Replace the front panel (see [Replacing the Front Panel](#)).
 13. Replace the computer cover (see [Replacing the Computer Cover](#)).
 14. Connect your computer and devices to an electrical outlet, and turn them on.
-

[Back to Contents Page](#)

Replacing Fans

Dell Studio™ 540 Service Manual

- [Replacing the Chassis Fan](#)
- [Replacing the Processor Fan and Heat Sink Assembly](#)

⚠ CAUTION: Before working inside your computer, read the safety information that shipped with your computer. For additional safety best practices information, see the Regulatory Compliance Homepage at www.dell.com/regulatory_compliance.

⚠ CAUTION: To guard against likelihood of electric shock, laceration by moving fan blades or other unexpected injuries, always unplug your computer from the electrical outlet before removing the cover.

Replacing the Chassis Fan

👉 NOTICE: Do not touch the fan blades when you are removing the chassis fan. This could damage the fan.

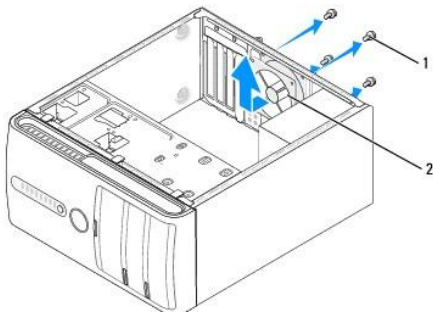

1	screws (4)	2	chassis fan
---	------------	---	-------------

1. Follow the procedures in [Before You Begin](#).
 2. Remove the computer cover (see [Replacing the Computer Cover](#)).
 3. Disconnect the chassis fan cable from the system board connector (SYS_FAN1).
 4. Remove the four screws securing the chassis fan.
 5. Lift the chassis fan away from the computer.
 6. To replace the chassis fan, slide it in place towards the back of the computer.
 7. Replace the four screws to secure the chassis fan.
 8. Connect the chassis fan cable to the system board connector (SYS_FAN1).
 9. Replace the computer cover (see [Replacing the Computer Cover](#)).
-

Replacing the Processor Fan and Heat Sink Assembly

⚠ CAUTION: Despite having a plastic shield, the heat sink fan assembly may be very hot during normal operation. Be sure that it has had sufficient time to cool before you touch it.

👉 NOTICE: Do not touch the fan blades when you are removing the processor fan and heat sink assembly. This could damage the fan.

👉 NOTICE: The processor fan with the heat sink is one single unit. Do not try to remove the fan separately.

1. Follow the procedures in [Before You Begin](#).
2. Remove the computer cover (see [Replacing the Computer Cover](#)).

3. Disconnect the processor fan cable from the CPU_FAN connector on the system board (see [System Board Components](#)).

4. Carefully move away any cables that are routed over the processor fan and heat sink assembly.

➔ **NOTICE:** To ensure maximum cooling for the processor, do not touch the heat transfer areas on the processor heat sink. The oils in your skin can reduce the heat transfer capability of the thermal pads.

5. Loosen the four captive screws securing the processor fan and heat sink assembly and lift it straight up.

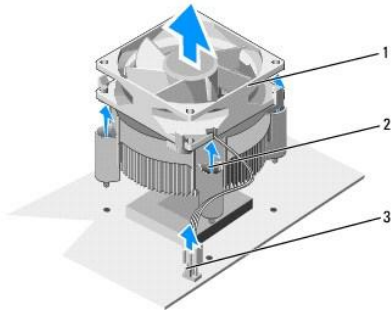

1	processor fan and heat sink assembly	2	captive screws (4)
3	processor fan connector (CPU_FAN)		

🔧 **NOTE:** The processor fan and heat sink assembly in your computer may not look exactly like the one shown in the illustration above.

6. To replace the processor fan and heat sink assembly, clean the thermal grease from the bottom of the heat sink.

➔ **NOTICE:** Ensure that you apply new thermal grease. New thermal grease is critical for ensuring adequate thermal bonding, which is a requirement for optimal processor operation.

7. Apply the new thermal grease to the top of the processor.

8. Place the processor fan and heat sink assembly with the side labeled "Rear" facing the back of the computer. Align the captive screws on the processor fan and heat sink assembly with the four metal screw hole projections on the system board.

9. Tighten the four captive screws.

🔧 **NOTE:** Ensure that the processor fan and heat sink assembly is correctly seated and secure.

10. Connect the processor fan and heat sink assembly cable to the CPU_FAN connector on the system board (see [System Board Components](#)).

11. Replace the computer cover (see [Replacing the Computer Cover](#)).

12. Connect your computer and devices to an electrical outlet, and turn them on.

Replacing the Front Panel

Dell Studio™ 540 Service Manual

⚠ CAUTION: Before working inside your computer, read the safety information that shipped with your computer. For additional safety best practices information, see the Regulatory Compliance Homepage at www.dell.com/regulatory_compliance.

1. Follow the procedures in [Before You Begin](#).
2. Remove the computer cover (see [Replacing the Computer Cover](#)).

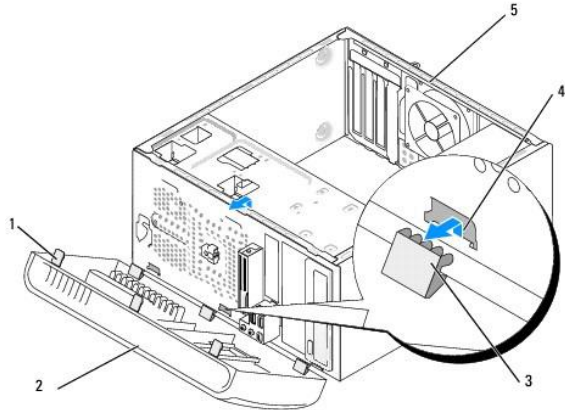

1	front panel grips (3)	2	front panel
3	front panel clamps (3)	4	clamp insert
5	back of the computer		

3. Grasp and lift the front panel grips one at a time to release it from the front of the computer.
4. Rotate and pull the front panel away from the front of the computer to release the front panel clamps from the clamp insert.
5. To replace the front panel, align and insert the front panel clamps in the clamp insert.
6. Rotate the front panel towards the computer until it snaps into place on the front of the computer.
7. Replace the computer cover (see [Replacing the Computer Cover](#)).

Replacing the Front I/O Panel

Dell Studio™ 540 Service Manual

⚠ CAUTION: Before working inside your computer, read the safety information that shipped with your computer. For additional safety best practices information, see the Regulatory Compliance Homepage at www.dell.com/regulatory_compliance.

1. Follow the procedures in [Before You Begin](#).
2. Remove the computer cover (see [Replacing the Computer Cover](#)).
3. Remove the front panel (see [Replacing the Front Panel](#)).
4. Remove any expansion cards (see [Replacing a PCI/PCI Express Card](#)).

🔍 NOTICE: Carefully note the routing of each cable before you disconnect it, so that you are sure to re-route cables correctly. An incorrectly routed or a disconnected cable could lead to computer problems.

5. Disconnect the cables connected to the I/O panel from the system board.
6. Remove the screw that secures the I/O panel to the chassis.
7. Carefully remove the existing I/O panel from the computer.

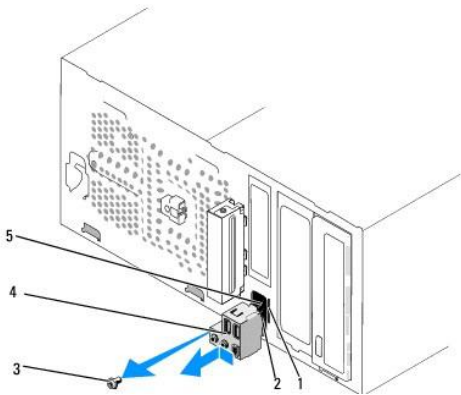

1	I/O panel clamp slot	2	I/O panel clamp
3	screw	4	I/O panel
5	cables		

8. To replace a new I/O panel, align and slide the I/O panel clamp into the I/O panel clamp slot.
9. Replace the screw that secures the I/O panel to the chassis.
10. Reconnect the cables to the system board.
11. Replace any expansion cards (see [Replacing a PCI/PCI Express Card](#)).
12. Replace the front panel (see [Replacing the Front Panel](#)).
13. Replace the computer cover (see [Replacing the Computer Cover](#)).
14. Connect your computer and devices to an electrical outlet, and turn them on.

Replacing Memory Module(s)

Dell Studio™ 540 Service Manual

CAUTION: Before working inside your computer, read the safety information that shipped with your computer. For additional safety best practices information, see the Regulatory Compliance Homepage at www.dell.com/regulatory_compliance.

1. Follow the procedures in [Before You Begin](#).
2. Remove the computer cover (see [Replacing the Computer Cover](#)).
3. Locate the memory modules on the system board (see [System Board Components](#)).
4. Press out the securing clip at each end of the memory module connector.

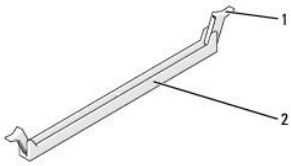

1	securing clip	2	memory module connector
---	---------------	---	-------------------------

5. Grasp the module and pull it upwards.

If the module is difficult to remove, gently ease the module back and forth to remove it from the connector.

NOTICE: Do not install ECC memory modules.

NOTICE: If you remove your original memory modules from the computer during a memory upgrade, keep them separate from any new modules that you may have, even if you purchased the new modules from Dell™. If possible, do not pair an original memory module with a new memory module. Otherwise, your computer may not start properly. The recommended memory configurations are:
A pair of matched memory modules installed in DIMM connectors 1 and 2.

or

A pair of matched memory modules installed in DIMM connectors 1 and 2 and another matched pair installed in DIMM connectors 3 and 4.

NOTE: If you install mixed pairs of PC2-5300 (DDR2 667-MHz) and PC2-6400 (DDR2 800-MHz) memory, the modules function at the speed of the slowest module installed.

6. Ensure that you install a single memory module in DIMM connector 1, the connector closest to the processor, before you install modules in any other connector.

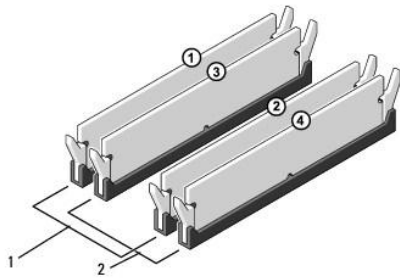

1	Pair A: matched pair of memory modules in connectors DIMM_1 and DIMM_2	2	Pair B: matched pair of memory modules in connectors DIMM_3 and DIMM_4
---	--	---	--

7. Align the notch on the bottom of the module with the with the tab on the memory module connector.

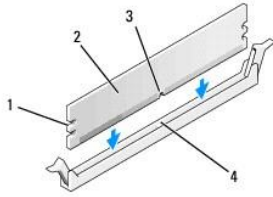

1	cutouts (2)	2	memory module
3	notch	4	memory module connector

NOTICE: To avoid damage to the memory module, press the module straight down into the connector while you apply equal force to each end of the module.

- Insert the module into the connector until the module snaps into position.

If you insert the module correctly, the securing clips snap into the cutouts at each end of the module.

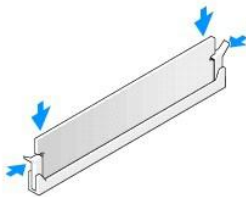

- Replace the computer cover (see [Replacing the Computer Cover](#)).
- Connect your computer and devices to electrical outlets, and then turn them on.
- If a message appears stating that memory size has changed, press <F1> to continue.
- Log on to your computer.
- Right-click the **My Computer** icon on your Microsoft®Windows® desktop and click **Properties**.
- Click the **General** tab.
- To verify that the memory is installed correctly, check the amount of memory (RAM) listed.

[Back to Contents Page](#)

Replacing the Power Supply

Dell Studio™ 540 Service Manual

-  **CAUTION:** Before working inside your computer, read the safety information that shipped with your computer. For additional safety best practices information, see the Regulatory Compliance Homepage at www.dell.com/regulatory_compliance.
-  **CAUTION:** To guard against likelihood of electric shock, laceration by moving fan blades or other unexpected injuries, always unplug your computer from the electrical outlet before removing the cover.
-  **NOTICE:** Do not perform the following steps unless you are familiar with hardware removal and replacement. Performing these steps incorrectly could damage your computer. For technical assistance, see the *Setup Guide*.

1. Follow the procedures in [Before You Begin](#).
2. Remove the computer cover (see [Replacing the Computer Cover](#)).

-  **NOTICE:** Note the location and ID of each power connector before disconnecting the power supply cables.

3. Follow the DC power cables that stem from the power supply and disconnect each connected power cable.

-  **NOTE:** Note the routing of the DC power cables underneath the tabs in the computer chassis as you remove them from the system board and drives. You must route these cables properly when you replace them to prevent them from being pinched or crimped.

4. Remove the four screws that secure the power supply to the back of the computer chassis.

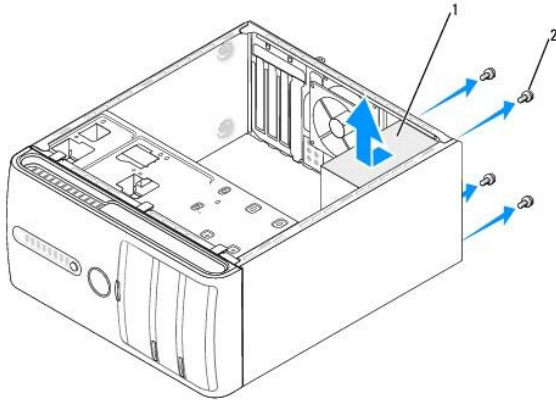

1	power supply	2	screws (4)
---	--------------	---	------------

5. Slide the power supply towards the front of the computer and lift it out.
6. Slide the replacement power supply towards the back of the computer.

-  **CAUTION:** Failure to replace and tighten all screws may cause electrical shock as these screws are a key part of the system grounding.

7. Replace all screws that secure the power supply to the back of the computer chassis.

-  **NOTICE:** Route the DC power cables under the chassis tabs. The cables must be properly routed to prevent the cables from being damaged.

8. Reconnect the DC power cables to the system board and drives.

-  **NOTE:** Double-check all cable connections to make sure they are secure.

9. Replace the computer cover (see [Replacing the Computer Cover](#)).

10. Connect your computer and devices to an electrical outlet, and turn them on.

[Back to Contents Page](#)

Replacing the Rubber Foot

Dell Studio™ 540 Service Manual

- CAUTION:** Before working inside your computer, read the safety information that shipped with your computer. For additional safety best practices information, see the Regulatory Compliance Homepage at www.dell.com/regulatory_compliance.
- CAUTION:** To guard against likelihood of electric shock, laceration by moving fan blades or other unexpected injuries, always unplug your computer from the electrical outlet before removing the cover.

1. Follow the procedures in [Before You Begin](#).
2. Lay your computer on its side.
3. Pull the rubber foot until it comes free.
4. To replace the rubber foot, align and insert the rubber foot into the rubber foot slot at the bottom of the computer.
5. Press the rubber foot pin into the rubber foot to secure the rubber foot to the chassis.

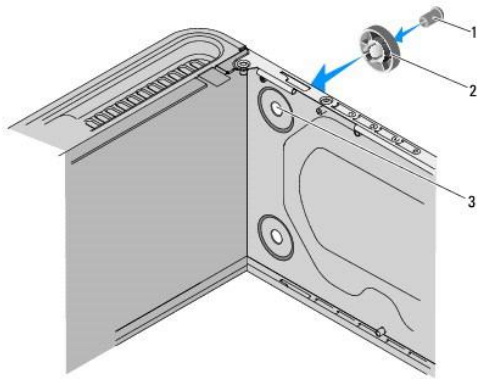

1	rubber foot pin	2	rubber foot
3	rubber foot slot		

Replacing the System Board

Dell Studio™ 540 Service Manual

CAUTION: Before working inside your computer, read the safety information that shipped with your computer. For additional safety best practices information, see the Regulatory Compliance Homepage at www.dell.com/regulatory_compliance.

NOTICE: Do not perform the following steps unless you are familiar with hardware removal and replacement. Performing these steps incorrectly could damage your system board. For technical assistance, see the *Setup Guide*.

1. Follow the procedures in [Before You Begin](#).
2. Remove the computer cover (see [Replacing the Computer Cover](#)).
3. Remove any expansion cards on the system board (see [Replacing a PCI/PCI Express Card](#)).

CAUTION: The processor heat sink can get very hot during normal operation. Be sure that the heat sink has had sufficient time to cool before you touch it.

4. Remove the processor and heat sink assembly (see [Replacing the Processor Fan and Heat Sink Assembly](#)).
5. Remove the processor (see [Replacing the Processor](#)).
6. Remove the memory modules (see [Replacing Memory Module\(s\)](#)), make a note which memory module is removed from each memory socket so that the memory modules can be installed in the same location after the board is replaced.

NOTICE: Carefully note the routing and location of each cable before you disconnect it, so that you are sure to re-route cables correctly. An incorrectly routed or a disconnected cable could lead to computer problems.

7. Disconnect all cables from the system board.
8. Remove the eight screws from the system board.

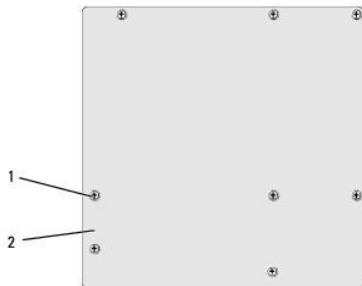

1	screws (8)	2	system board
---	------------	---	--------------

9. Lift the system board up and out.

NOTICE: If you are replacing the system board, visually compare the replacement system board to the existing system board to make sure that you have the correct part.

NOTE: Some components and connectors on replacement system boards may be in different locations compared to the existing connectors on the system board.

NOTE: Jumper settings on replacement system boards are preset at the factory.

10. Orient the system board by aligning the screw holes on the system board with the screw holes on the chassis.
11. Replace the eight screws to secure the system board to the chassis.
12. Replace the cables that you removed from the system board.
13. Replace the memory modules (see [Replacing Memory Module\(s\)](#)).
14. Replace the processor (see [Replacing the Processor](#)).

15. Replace the processor and the heat sink assembly (see [Replacing the Processor](#)).

 **NOTICE:** Ensure that the heat sink assembly is correctly seated and secure.

16. Replace any expansion cards on the system board (see [Installing a PCI/PCI Express Card](#)).

17. Replace the computer cover (see [Replacing the Computer Cover](#)).

18. Connect your computer and devices to an electrical outlet, and turn them on.

19. Flash the system BIOS, as needed.

 **NOTE:** For information on flashing the system BIOS, see [Flashing the BIOS](#).

[Back to Contents Page](#)

System Setup

Dell Studio™ 540 Service Manual

- [Overview](#)
- [Clearing Forgotten Passwords](#)
- [Clearing CMOS Settings](#)
- [Flashing the BIOS](#)

Overview

Use system setup to:

- 1 Change the system configuration information after you add, change, or remove any hardware in your computer
- 1 Set or change a user-selectable option such as the user password
- 1 Read the current amount of memory or set the type of hard drive installed

 **NOTICE:** Unless you are an expert computer user, do not change the settings for this program. Certain changes can make your computer work incorrectly.

 **NOTE:** Before you use system setup, it is recommended that you write down the system setup screen information for future reference.

Entering System Setup

1. Turn on (or restart) your computer.
2. When the blue DELL™ logo is displayed, watch for the F2 prompt to appear and then press <F2> immediately.

 **NOTE:** The F2 prompt indicates that the keyboard has initialized. This prompt can appear very quickly, so you must watch for it to display, and then press <F2>. If you press <F2> before you are prompted, this keystroke will be lost. If you wait too long and the operating system logo appears, continue to wait until you see the Microsoft® Windows® desktop. Then, shut down your computer (see [Turning Off Your Computer](#)) and try again.

System Setup Screens

The system setup screen displays current or changeable configuration information for your computer. Information on the screen is divided into three areas: the [options list](#), [active options field](#), and [key functions](#).

<p>Menu — Appears on top of the System Setup window. This field provides a menu to access to the System Setup options. Press <←> and <→> keys to navigate. As a Menu option is highlighted, the Options List, lists the options that define the hardware installed on you computer.</p>		
<p>Options List — Appears on the left side of the System Setup window. The field lists features that define the configuration of your computer, including installed hardware, power conservation, and security features. Scroll up and down the list with the up- and down-arrow keys. As an option is highlighted, the Options Field displays the option's current and available settings.</p>	<p>Options Field — Appears on the right side of Options List and contains information about each option listed in the Options List. In this field you can view information about your computer and make changes to your current settings. Press <Enter> to make changes to your current settings. Press <ESC> to return to the Options List.</p> <p>NOTE: Not all settings listed in the Options Field are changeable.</p>	<p>Help — Appears on the right side of the System Setup window and contains help information about the option selected in Options List.</p>
<p>Key Functions — Appears below the Options Field and lists keys and their functions within the active system setup field.</p>		

System Setup Options

 **NOTE:** Depending on your computer and installed devices, the items listed in this section may appear, or may not appear exactly as listed.

Main	
System Date	Displays current date settings, in the mm:dd:yy format.
System Time	Displays current time settings, in the in the hh:mm:ss format.
SATA0	Displays the SATA drive integrated on SATA0.
SATA1	Displays the SATA drive integrated on SATA1.
SATA2	SATA Port not present.
SATA3	SATA Port not present.
SATA4	Displays the SATA drive integrated on SATA4.

SATA5	Displays the SATA drive integrated on SATA5.
System Info	Lists the BIOS version, system name, asset tag, and service tag.
Memory Info	Indicates amount of installed memory, memory speed, channel mode (dual or single), and type of memory installed.
Advanced	
CPU type	Indicates the type of CPU installed.
L2 Cache	Indicates the amount of CPU L2 cache.
Advanced Chipset Features	Indicates amount of video memory (32 MB by default).
Integrated Peripherals	Allows you to enable or disable the integrated devices and ports on your system.
CPU Configuration	Allows you to enable or disable the CPU features that enhance the performance of the system.
USB Configuration	Allows you to enable or disable the USB controller.
Power	
Power Management Setup	
ACPI Suspend Type	Specifies the ACPI suspend type. The default is S3.
Remote Wake Up	This option turns on the computer when a user tries to access the computer through the LAN.
Auto Power On	Enables you to set an alarm to turn on the computer automatically.
Auto Power On Date	Enables you to set the date to turn on the computer automatically (0 by default).
Auto Power On Time	Enables you to set the time to turn on the computer automatically (0:00:00 by default).
AC Recovery	Off; On; Last (Off by default).
Boot	
Boot Device Priority	Sets the boot device sequence. Only the bootable devices that are connected to the computer are listed as options.
Removable Device Priority	Sets the boot priority among the attached removable devices.
Hard Disk Boot Priority	Sets the hard drive boot priority. The items displayed are dynamically updated according to the hard drives detected.
CD/DVD Boot Priority	Sets the CD/DVD drive boot priority. The items displayed are dynamically updated according to the hard drives detected.
Boot Settings Configuration	Configure Fast Boot, Numlock and Keyboard errors.
Security	Provides options to enable, disable or change the passwords.
Exit	
Exit Options	Provides options to Exit Saving Changes , Exit Discarding Changes , Load Setup Default , and Discard Changes .

Boot Sequence

This feature allows you to change the boot sequence for devices.

Boot Options

1. **Hard Drive** — The computer attempts to boot from the primary hard drive. If no operating system is on the drive, the computer generates an error message.
1. **CD/DVD Drive** — The computer attempts to boot from the CD/DVD drive. If no CD/DVD is in the drive, or if the CD/DVD has no operating system, the computer generates an error message.
1. **USB Flash Device** — Insert the memory device into a USB port and restart the computer. When **F12 = Boot Menu** appears in the upper-right corner of the screen, press <F12>. The BIOS detects the device and adds the USB flash option to the boot menu.

 **NOTE:** To boot to a USB device, the device must be bootable. To ensure that your device is bootable, check the device documentation.

Changing Boot Sequence for the Current Boot

You can use this feature to change the current boot sequence, for example, to boot from the CD/DVD drive to run the Dell Diagnostics on the Drivers and Utilities media. On completion of diagnostic tests, the previous boot sequence is restored.

1. If you are booting to a USB device, connect the USB device to a USB connector.
2. Turn on (or restart) your computer.
3. When **F2 = Setup**, **F12 = Boot Menu** appears in the upper-right corner of the screen, press <F12>.

If you wait too long and the operating system logo appears, continue to wait until you see the Microsoft Windows desktop. Then shut down your computer and try again.

The **Boot Device Menu** appears, listing all available boot devices. Each device has a number next to it.

4. On the **Boot Device Menu** choose the device you want to boot from.

For example, if you are booting to a USB memory key, highlight **USB Flash Device** and press <Enter>.

 **NOTE:** To boot to a USB device, the device must be bootable. To ensure your device is bootable, check the device documentation.

Changing Boot Sequence for Future Boots

1. Enter system setup (see [Entering System Setup](#)).
2. Use the arrow keys to highlight the **Boot** menu option and press <Enter> to access the menu.

 **NOTE:** Write down your current boot sequence in case you want to restore it.

3. Press the up- and down-arrow keys to move through the list of devices.
4. Press plus (+) or minus (-) to change the boot priority of device.

Clearing Forgotten Passwords

 **CAUTION:** The computer must be disconnected from the electrical outlet to clear the Password setting.

1. Follow the procedures in [Before You Begin](#).
2. Remove the computer cover (see [Replacing the Computer Cover](#)).
3. Locate the 3-pin password connector (CLEAR_PW) on the system board (see [System Board Components](#)).

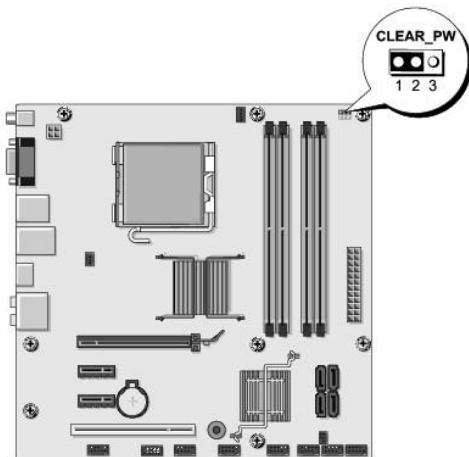

4. Remove the 2-pin jumper plug from pins 2 and 3 and fix it on pins 1 and 2.
 5. Wait for approximately five seconds to clear the password.
 6. Remove the 2-pin jumper plug from pins 1 and 2 and replace it on pins 2 and 3 to enable the password feature.
 7. Replace the computer cover (see [Replacing the Computer Cover](#)).
 8. Connect your computer and devices to electrical outlets, and turn them on.
-

Clearing CMOS Settings

⚠ CAUTION: Before you begin any of the procedures in this section, follow the safety instructions located that shipped with your computer.

⚠ CAUTION: The computer must be disconnected from the electrical outlet to clear the CMOS setting.

1. Follow the procedures in [Before You Begin](#).
2. Remove the computer cover (see [Replacing the Computer Cover](#)).
3. Locate the 3-pin CMOS jumper (CLEAR_CMOS) on the system board (see [System Board Components](#)).

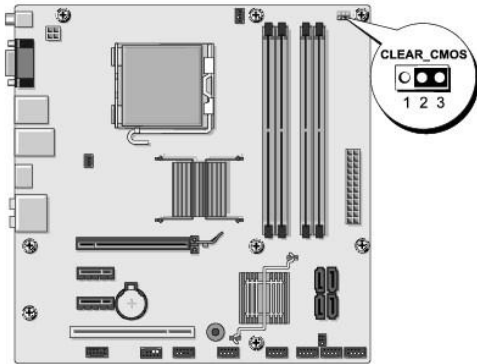

4. Remove the jumper plug from the CMOS jumper (CLEAR_CMOS) pins 1 and 2.
5. Place the jumper plug on the CMOS jumper (CLEAR_CMOS) pins 2 and 3 and wait approximately five seconds.
6. Remove the jumper plug and replace it on the CMOS jumper (CLEAR_CMOS) pins 1 and 2.
7. Replace the computer cover (see [Replacing the Computer Cover](#)).
8. Connect your computer and devices to electrical outlets, and turn them on.

Flashing the BIOS

The BIOS may require flashing when an update is available or when replacing the system board.

1. Turn on the computer.
2. Locate the BIOS update file for your computer at the Dell Support website at support.dell.com.

NOTE: For non U.S. regions, choose your country/region from the drop-down list at the bottom of the Dell support website and then locate the BIOS update file for your computer.

3. Click **Download Now** to download the file.
4. If the **Export Compliance Disclaimer** window appears, click **Yes, I Accept this Agreement**.

The **File Download** window appears.

5. Click **Save this program to disk**, and then click **OK**.

The **Save In** window appears.

6. Click the down arrow to view the **Save In** menu, select **Desktop**, and then click **Save**.

The file downloads to your desktop.

7. Click **Close** when the **Download Complete** window appears.

The file icon appears on your desktop and is titled the same as the download BIOS update file.

8. Double-click the file icon on the desktop and follow the instructions on the screen.

[Back to Contents Page](#)

Technical Overview

Dell Studio™ 540 Service Manual

- [Inside View of Your Computer](#)
- [System Board Components](#)

⚠ CAUTION: Before working inside your computer, read the safety information that shipped with your computer. For additional safety best practices information, see the Regulatory Compliance Homepage at www.dell.com/regulatory_compliance.

Inside View of Your Computer

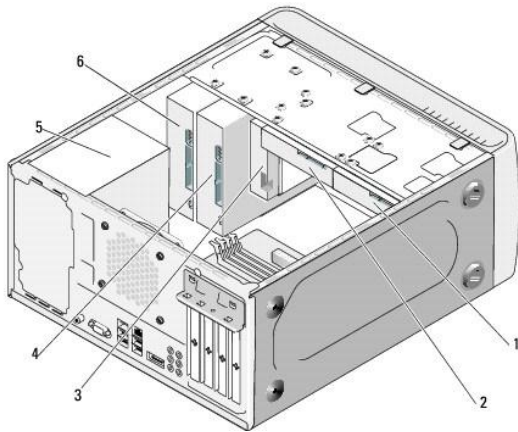

1	optional hard drive	2	hard drive
3	FlexDock	4	optional CD or DVD drive
5	power supply	6	CD or DVD drive

System Board Components

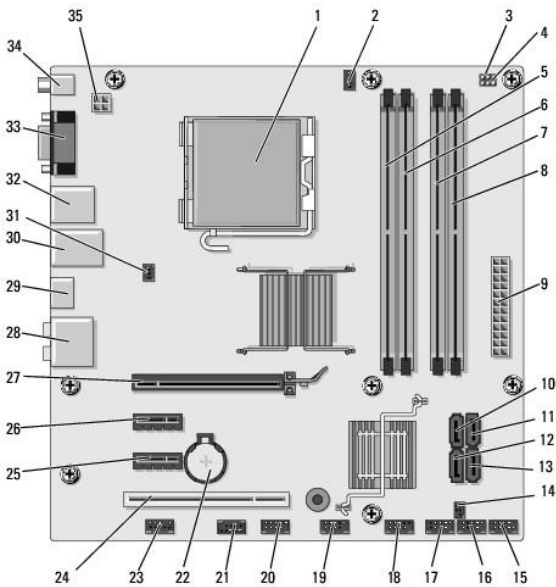

1	processor socket (CPU)	2	processor fan connector
---	------------------------	---	-------------------------

			(CPU_FAN)
3	password jumper (CLEAR_PW)	4	CMOS jumper (CLEAR_CMOS)
5	memory module connector (DIMM_1)	6	memory module connector (DIMM_3)
7	memory module connector (DIMM_2)	8	memory module connector (DIMM_4)
9	main power connector (ATX POWER)	10	serial ATA drive connector (SATA0)
11	serial ATA drive connector (SATA1)	12	serial ATA drive connector (SATA5)
13	serial ATA drive connector (SATA4)	14	S/PDIF out connector (SPDIF_OUT1)
15	front panel connector (F_PANEL)	16	front USB connector (F_USB5)
17	Media Card Reader USB connector (F_USB4)	18	front USB connector (F_USB3)
19	front I/O USB connector (F_USB2)	20	FlexDock USB connector (F_USB1)
21	front 1394 connector (F_1394)	22	battery socket
23	front audio connector (F_AUDIO)	24	PCI connector (PCI 1)
25	PCI Express x1 connector (PCIE_X1_2)	26	PCI Express x1 connector (PCIE_X1_1)
27	PCI Express x16 connector (PCIE X16)	28	audio connectors (AUDIO)
29	HDMI connector (HDMI)	30	2 USB connectors and 1 LAN connector
31	chassis fan connector (SYS_FAN1)	32	2 USB connectors and 1 IEEE 1394 connector
33	video connector (VGA)	34	S/PDIF connector (SPDIF_OUT2)
35	power for processor (ATX_CPU)		

[Back to Contents Page](#)

[Back to Contents Page](#)

Dell Studio™ 540 Service Manual



NOTE: A NOTE indicates important information that helps you make better use of your computer.



NOTICE: A NOTICE indicates either potential damage to hardware or loss of data and tells you how to avoid the problem.



CAUTION: A CAUTION indicates a potential for property damage, personal injury, or death.

Information in this document is subject to change without notice.
© 2008 Dell Inc. All rights reserved.

Reproduction of these materials in any manner whatsoever without the written permission of Dell Inc. is strictly forbidden.

Trademarks used in this text: *Dell*, the *DELL* logo, and *Dell Studio* are trademarks of Dell Inc.; *Microsoft* and *Windows* are either trademarks or registered trademarks of Microsoft Corporation in the United States and/or other countries.

Other trademarks and trade names may be used in this document to refer to either the entities claiming the marks and names or their products. Dell Inc. disclaims any proprietary interest in trademarks and trade names other than its own.

July 2008 Rev. A00

[Back to Contents Page](#)