

Service Manual

**W365H, W375H, W3105H,
W3130H, W3180H, W3240H, W3300H
Wascator FOM71 CLS
Clarus Control**

Overview	Safety precautions	1
	Technical data	2
	Machine presentation	3
	Programmes	4
		5
Service instructions	Regular maintenance	11
	Troubleshooting	12
Machine components and parts	Control unit	21
		22
	Programme unit	23
		24
		25
		26
		27
		28
	Door and door lock	29
	Motor and motor control	30
		31
		32
		33
		34
		35
		36
		37
	Drain valve	38
	Detergent compartment	39
	Heating	40
		41
		42
	Frame	43
	Options	50

1. Safety precautions

Contents

Safety precautions	3
Warnings	3

Safety Precautions

- The machine is only intended for washing with water.
- Do not allow minors to operate the machine.
- Installation and maintenance work should only be done by authorized persons
- Do not bypass the door lock of the machine.
- Any leaks, e.g. a worn-out door seal, should be repaired immediately.
- Prior to repairs or maintenance, be sure to read the corresponding handbooks and service manuals.
- Do not flush the machine with water.

Warnings

The service manual includes the following warnings that warn of possible injuries. Next to each warning text, a page reference refers to the page where the warning can be found in the manual.



DANGER



Be careful when measuring the electric components in the motor control. All components have a potential difference of approx. 300 V in relation to protective earth and neutral. When the green LED on the motor control card is lit, the components carry dangerous voltages. The motor control lose all voltage about 10-30 seconds after the voltage has been disconnected and the motor has stopped.

Chapter 30, pages 2 and 5.

2. Technical data

Contents

Technical data	3
Physical features	3
Connections	4

Technical data

Physical features

Model types

Washer extractor	W365H	W375H	W3105H	W3130H	W3180H	W3240H	W3300H
	FOM71	CLS					

Inner drum

Volume	l	65	75	105	130	180	240	300
Diameter	mm	520	520	595	650	725	795	795
Depth	mm	315	365	360	390	435	485	610

Capacity, dry weight

Filling factor 1:10	kg	6,5	7,5	10,5	13	18	24	30
Filling factor 1:13	kg	5	5,8	8	10	13,8	18,5	23

Drum speed

Washing	rpm	52	52	49	49	44	42	42
Extraction	rpm	1100	1100	1025	980	930	890	820

G factor

Extraction		350	350	350	350	350	350	300
------------	--	-----	-----	-----	-----	-----	-----	-----

Dimensions

Width	mm	720	720	830	910	970	1020	1020
Depth	mm	690	690	705	785	870	915	1060
Height	mm	1115	1115	1300	1325	1410	1445	1445

Service area,
recommended

On the sides	mm	50	50	50	50	50	50	50
Behind	mm	500	500	500	500	500	500	500

Weight

Net	kg	144	159	201	267	350	400	509
-----	----	-----	-----	-----	-----	-----	-----	-----

Connections

Model types

Washer extractor	W365H	W375H	W3105H	W3130H	W3180H	W3240H	W3300H
	FOM71	CLS					

Motor input

During extract cycle
at nominal voltage

No load, no imbalance	W	550	650	860	1040	1700	1600	1440
Nominal load	W	860	950	1150	1470	2100	2350	1900
Max. load, max. imbalance	W							

Water valves

Connection	DN	20	20	20	20	20	20	20
Recommended water pressure	kPa	200-600	200-600	200-600	200-600	200-600	200-600	200-600
Pressure limits	kPa	50-1000	50-1000	50-1000	50-1000	50-1000	50-1000	50-1000
Capacity at 300 kPa	l/min	20	20	20	20	60	60	60

Drain valve

Outer diameter of connection	mm	50/75	50/75	50/75	75	75	75	75
Capacity	l/min	170	170	170	170	170	170	170

Steam valve

Connection	DN	15	15	15	15	15	15	15
Recommended steam pressure	kPa	300-600	300-600	300-600	300-600	300-600	300-600	300-600
Pressure limits	kPa	50-800	50-800	50-800	50-800	50-800	50-800	50-800

3. Machine presentation

Contents

Description	3
General	3
Function	4
General	4
Programme unit	5
Motor and motor control	6
Door lock	7
Heating	8
Water connections	8
Rear control unit	8
Detergent compartment	9
Drain valve	9
Frame and dampers	9

Description

General

Fig. 1 The machines covered in this manual include:

1

Drum volume (litres)	Model type
65	W365H, Wascator FOM71 CLS
75	W375H
100	W3100H
130	W3130H
180	W3180H
240	W3240H
300	W3300H

The programme unit contains a microprocessor with a number of standard programmes for normal wash cycles. New programmes, specially prepared for specific applications, can be easily programmed by the customer, either using the control panel on the washing machine or using a special computer application. The programmes are then transferred to the washing machine on memory cards.

The motor is frequency-controlled and is controlled by an advanced motor control. This allows precise and flexible control of the motor rpm for any application.

The machines are supplied to customer specifications with e.g. electric or steam heating or no heating, and may be connected to various combinations of cold, warm and hard water.

The machines are designed for installation in hotels, laundries, factories, hospitals, various institutions, etc.

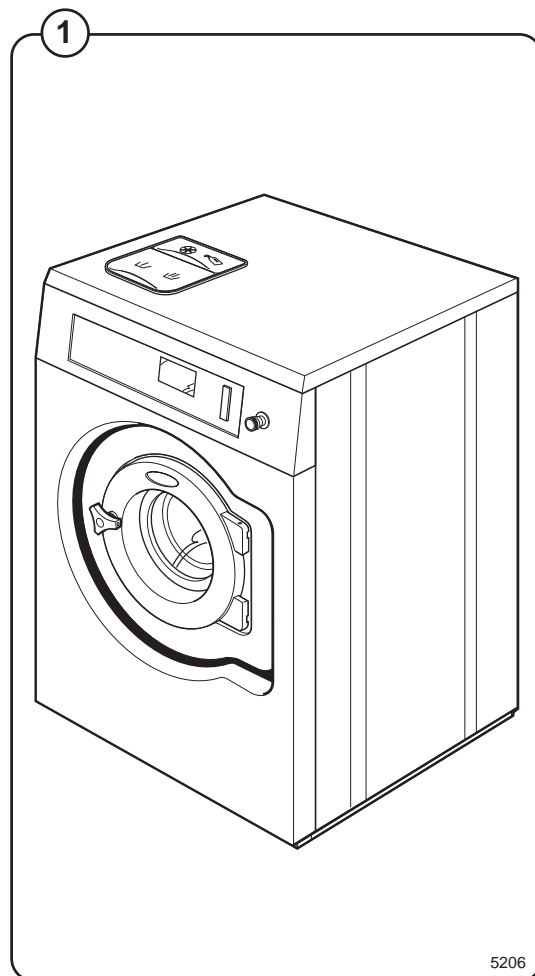

Function

General

Fig. 2 This section presents an overview of the functions of the machine. Most functions are then presented in detail in separate chapters in the service manual.

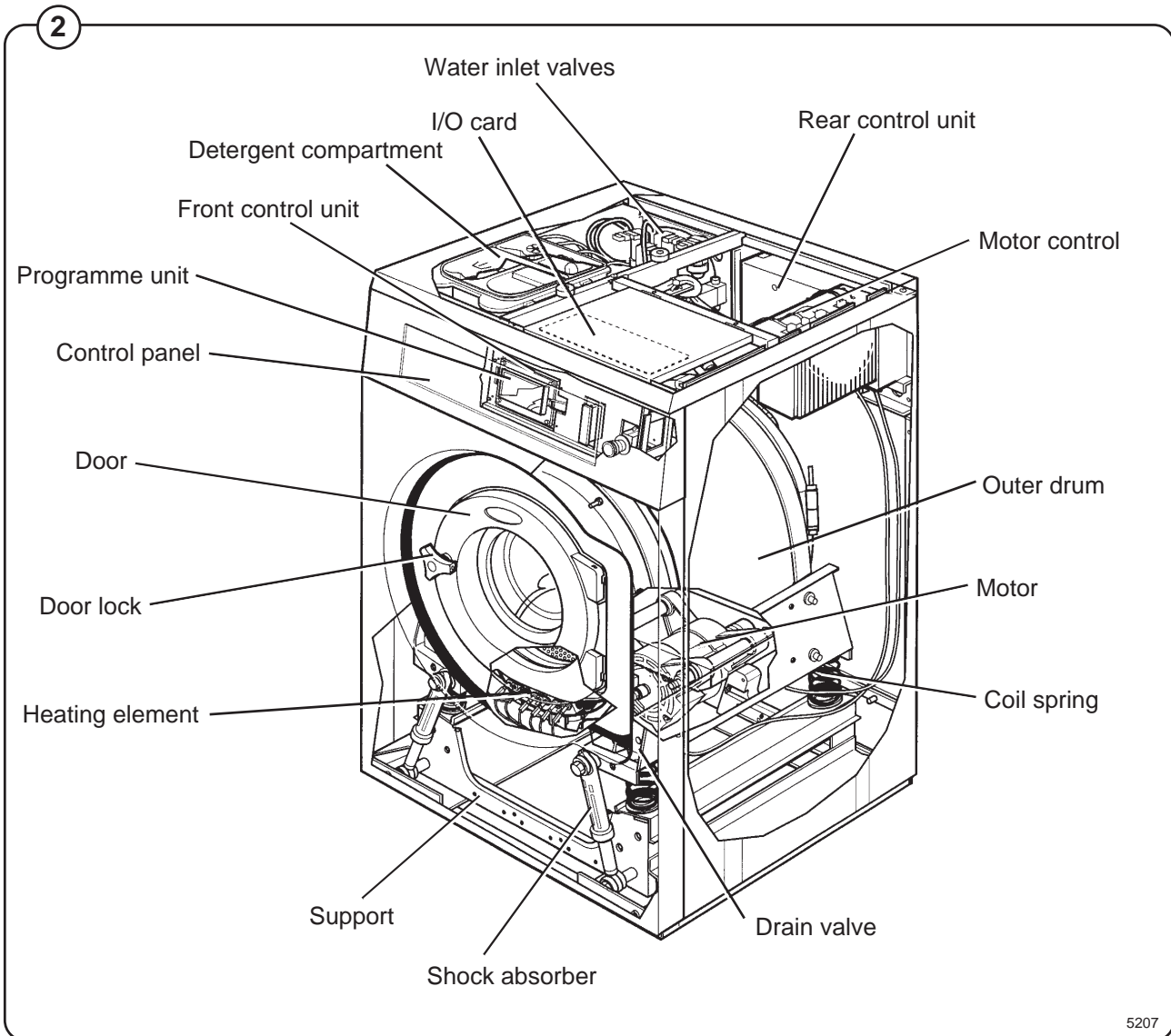

Programme unit

Fig. 3 The programme unit is made up of the CPU card, the display card, card reader and one or two I/O cards. The programme unit holds a number of standard programmes, but it is also possible to programme user-specific washing programmes, either using the control panel on the machine or a computer.

Fig. 4 The programme unit card reader is used to transfer programmes between a computer and the washing machine or between different washing machines.

The programme unit card reader is used to transfer programmes between a computer and the washing machine or between different washing machines.

The programme unit communicates with the motor control through a serial interface. One or more I/O cards control the water valves, drain and heating of the machine. The control signals are sent via a communication card in the rear control unit to the various components. The communication card has connectors for connecting to various external components, such as detergent pumps or external water valves.

The programme unit of the machine is described in detail in section 23. Programme unit.

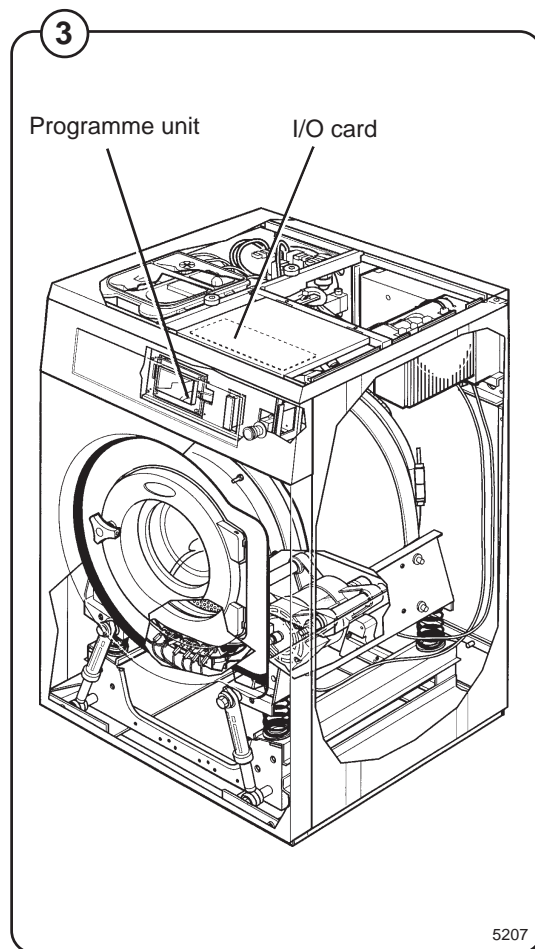

5207

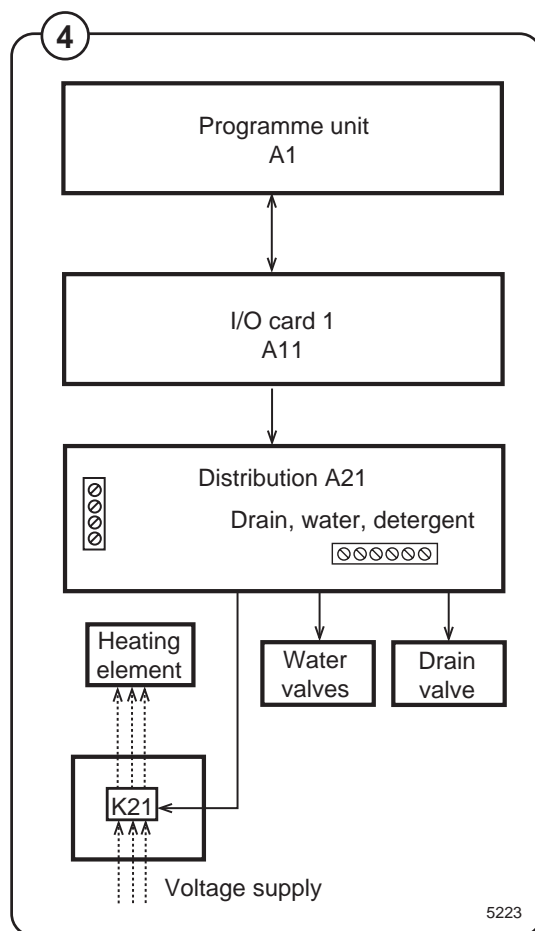

5223

Motor and motor control

Fig. 5 A frequency-regulated motor using a drive belt drives the drum. The motor is situated on a motor shelf, under the outer drum with a tensioner device for the drive belt.

Fig. 6 The motor control relies on microcomputer control and controls acceleration, rpm and retardation of the drum with high precision. Further, the motor control can supply simultaneous values that can be used as warnings for unbalanced loads and to calculate the weight of the load.

The motor control communicates with the programme unit through a serial interface.

The motor and motor control is described in detail in section 30. **Motor and motor control.**

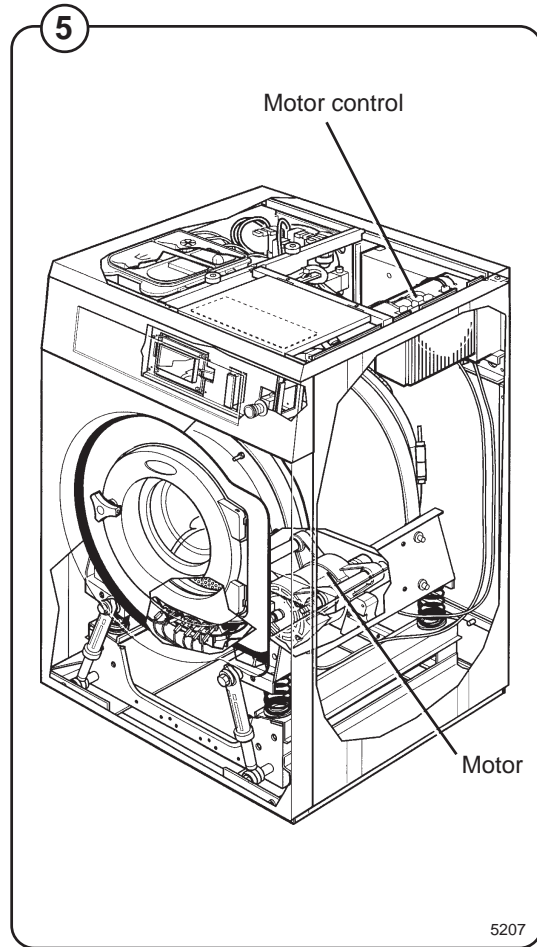

5207

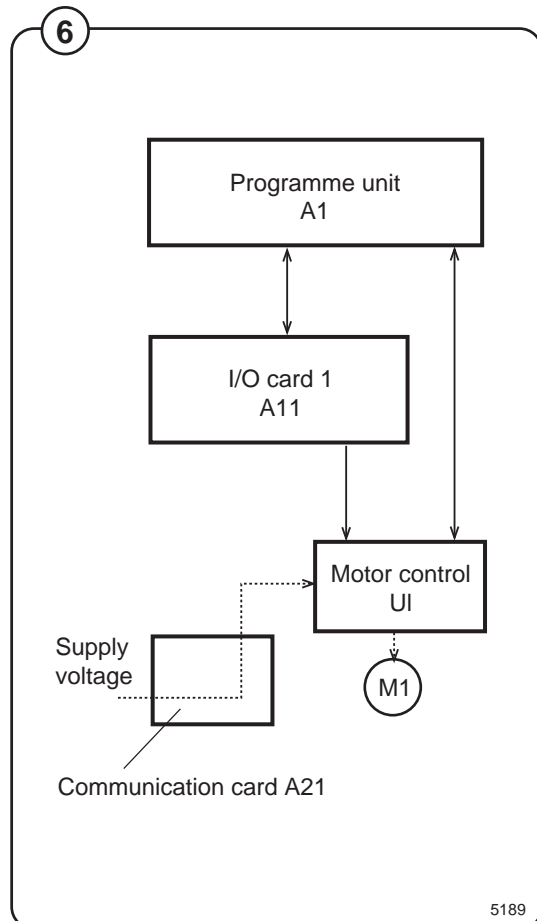

5189

Door lock

Fig. 7 The door lock is an electro-mechanical type with double safety switches. The lock is bi-stable, i.e., it needs to receive an active pulse from the control in order to both lock and unlock the door.

Fig. 8 A separate printed circuit board, called door lock control, can be fitted onto the programme unit. This board controls locking and unlocking. The card has separate checks for empty drum and stopped drum. Together with the checks built into the programme unit, this guarantees that the door cannot be opened by a mistake.

The door lock on the machine is described in detail in section 29. Door and door lock.

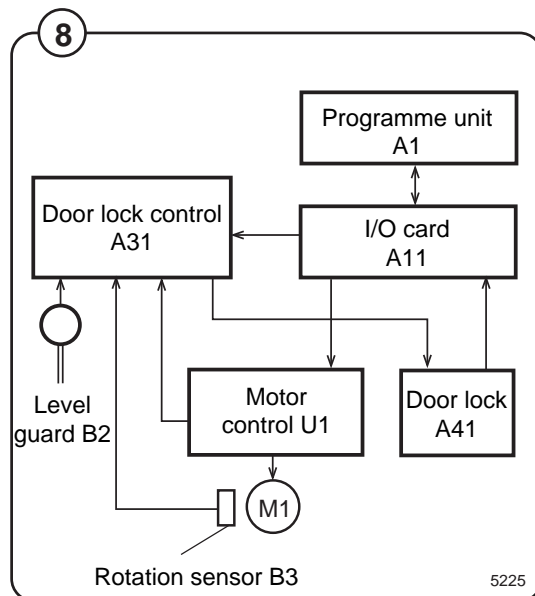
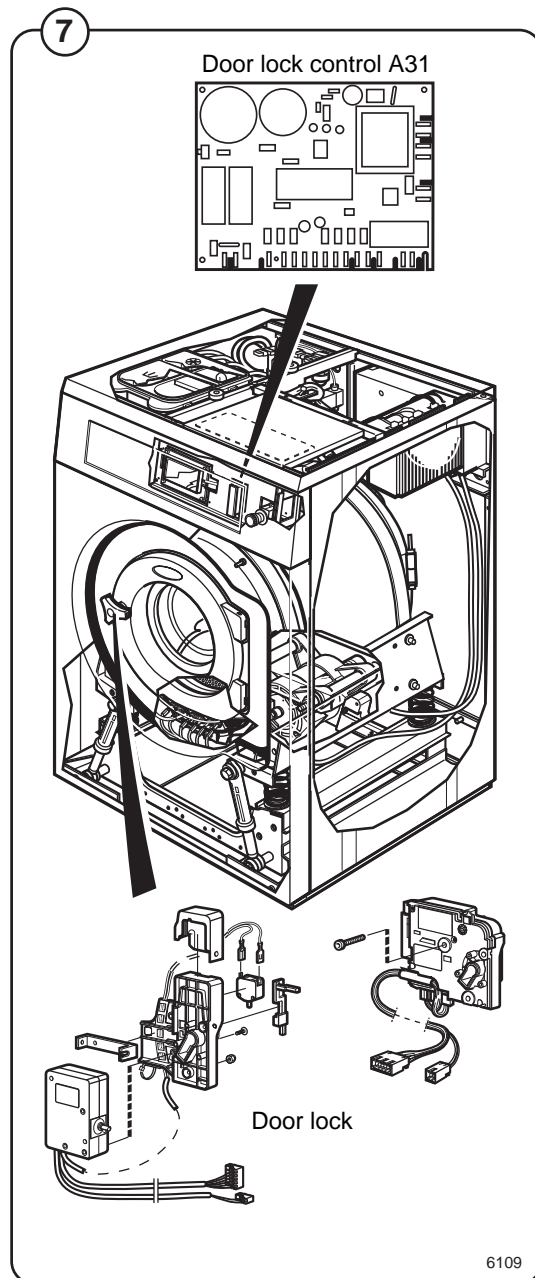

Heating

Fig. 9 When using electric heating, the water for washing is heated by three heating elements accessible from the front of the machine.

The machine can also be fitted with steam heating using a steam valve fitted on the rear of the machine.

The heating system of the machine is described in detail in section **40. Heating**.

Water connections

Fig. 9 Depending on the machine size and customer specifications, the machine has one, two, three or four inlet valves.

This unit also has eight connections for external detergent supply.

Rear control unit

Fig. 9 This unit contains the main power switch and connection block for the input voltage, heating contactor and one or two communication cards with outputs that control the water and drain valves of the machine as well as the heating. There are also connection blocks for connection to e.g., an external detergent supply.

The rear control unit of the machines is described in detail in section **21. Control unit**.

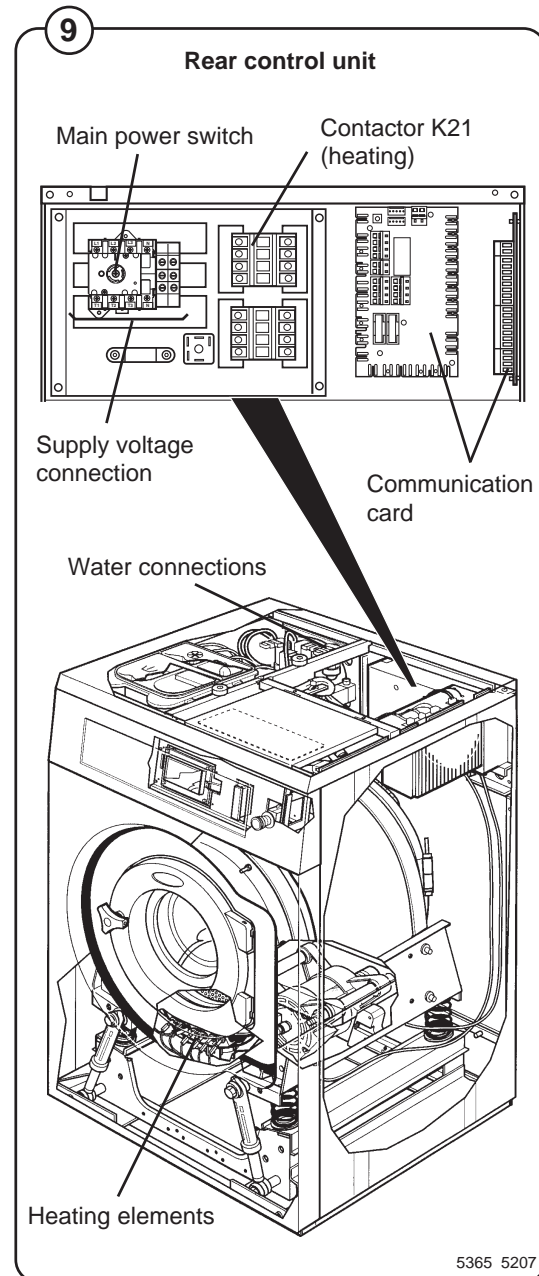

Detergent compartment

Fig. 10 The compartment is divided into four for pre-wash, main wash, rinse and bleaching-agent/liquid detergent.

The detergent compartment of the machines is described in detail in section **39. Detergent compartment**.

Drain valve

Fig. 10 This valve is a diaphragm valve that opens and closes by way of the water pressure. The control valve is situated next to the water valves.

The drain valve of the machine is described in detail in section **38. Drain valve**.

Frame and dampers

Fig. 10 The drum assembly is freely suspended by springs and is allowed to move in relation to the frame. This means a minimum of vibrations are transferred to the frame, which implies simplified installation since the machine need not be placed on a concrete base.

The machine uses four coil springs between the frame and drum assembly. Each spring is fitted to one or two shock absorbers that dampen drum movement.

The machine support is described in detail in section **43. Frame**.

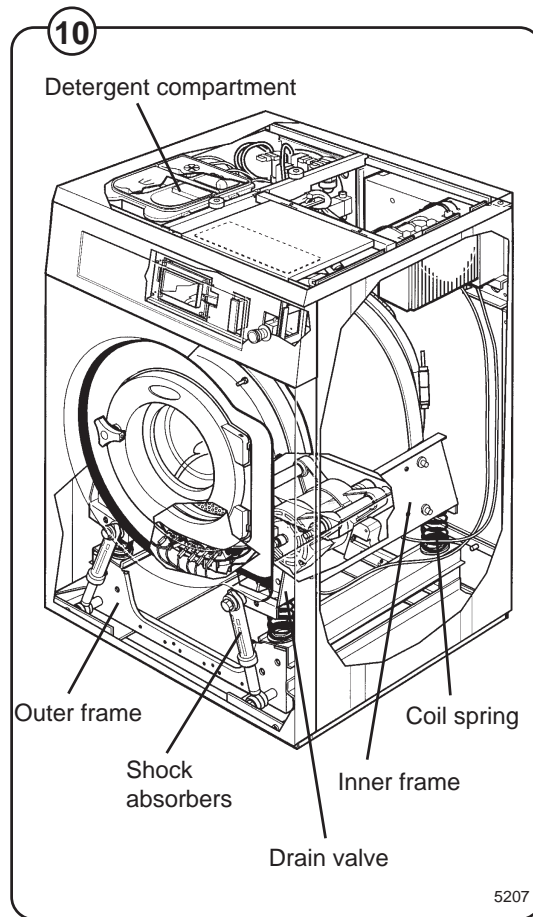

11. Regular maintenance

Contents

Daily	3
Every third month	3

To maintain correct and proper functioning and to prevent interruption of service, the following maintenance scheme should be adhered to.

The maintenance interval should be adapted to how frequently the machine is used.

Daily

- Check the door and door lock:
 - Let the door remain open and try starting the machine. The machine should not start.
 - Close the door, start the machine and try opening the door. It should not be possible to open the door until the drum has stopped turning.
 - Check that the door does not leak.
 - Clean the door seal, removing any detergent and fluff.
- Check that the drain valve does not leak during the wash cycle.
- Clean out any detergent remaining in the detergent compartment. Rapid advance through a program and let the water rinse the compartment:

Every third month



- Check that the door does not leak.
- Check the drain valve and remove any fluff.
- Inspect the interior of the machine (during an actual wash cycle to ensure that no leaks are noticed) by:
 - Turning of the main power switch of the machine.
 - Remove the top cover and the protective front and rear plates.

-
- Verify that all internal hoses do not leak.
 - Inspect the drive belt. Adjust the tension or replace if necessary (see section **30. Motor**).
 - Check that water does not leak onto the floor.
 - If the heating time is unusually long, check the heating elements (see section **40. Heating**). If the water is very hard, check whether there are lime deposits on the heating elements. Decalcify the elements if necessary. Adapt the amount of deliming agent to the manufacturer's guidelines.
 - Never switch on the heating elements when there is no water in the machine. This will cause the slow-blow fuse to trigger.
 - Inspect the shock absorbers and coil springs.

12. Troubleshooting

Contents

General information about troubleshooting	3
Precautions	3
Measurements	3
Errors with no error codes	4
Errors with error codes	4
Error indication	4
Resetting an error indication	4
Error codes	4
Service programme	8
Opening the service programme	8
To control the machine functions	10
I/O card inputs	11
To end the service programme	11
Errors with no error codes	12
No indication in the display window (machine not responding or operates apart from this)	12
Errors with error codes	13
NO WATER	13
DOOR OPEN	15
DOOR UNLOCKED	17
NTC LOW TEMP	18
NTC HIGH TEMP	19
WATER IN DRUM	20
MACHINE OVERFILLED	21
NO HEATING	22
NOT DRAINED	23
UNBALANCE SENSOR FAULT	24
NO MOTOR COMM	25
LEVEL CALIBRATION	26
WEIGHT FROM SCALE	27
EMERGENCY STOP	28
DOOR LOCK	29
START NOT ALLOWED	30
MIS COMMUNICATION	31
INTERLOCK STATUS	32
IO COMMUNICATION	33
LOW OIL LEVEL	34
PHASE	35
AUT. LEVEL CALIB.	36
LEVEL NOT CALIBRATED	37
NO SCALE CONNECTED	38
HEAT SINK TOO HOT	39
MOTOR TOO HOT	40
NO INTERLOCK	42
MOTOR SHORTNING	43
INTERLOCK HARDWARE	44
LOW DC VOLTAGE	45
HIGH DC VOLTAGE	46
RIPPEL ON DC BUS	47
LINE INTERRUPT	48
KLIXON CIRCUIT	49
Troubleshooting the keypad in the display unit	50

General information about troubleshooting

The troubleshooting section is used to pinpoint a fault on the machine to a specific defective component or unit.

If the power supply is interrupted, the programme memory will keep the select programme in its memory for approx. 3-5 minutes.

Within this time period, the machine automatically restarts after the power interruption.

Precautions

Only authorized personnel is allowed to troubleshoot the machine.

Prior to commencing troubleshooting, pay close attention to the precautions in section 1.

If the power is on, be very careful when working on the the machine.



DANGER



Be very careful when measuring the motor controller since all components have a potential difference of about 300 V compared to Ground and Neutral.

When the green LED is lit, all components are powered with dangerous voltage.

When the power supply to the machine is interrupted and the motor has stopped, the motor controller will does lose power until after 10-30 seconds.

Measurements

For information about measurement points, components and voltages, please refer to the wiring diagrams for the machine.

Errors with no error codes

This section includes troubleshooting charts for errors for which no error code is generated.

Errors with error codes

Error indication

Fig. 1 Programme or machine errors are indicated by an alarm text in the display window.

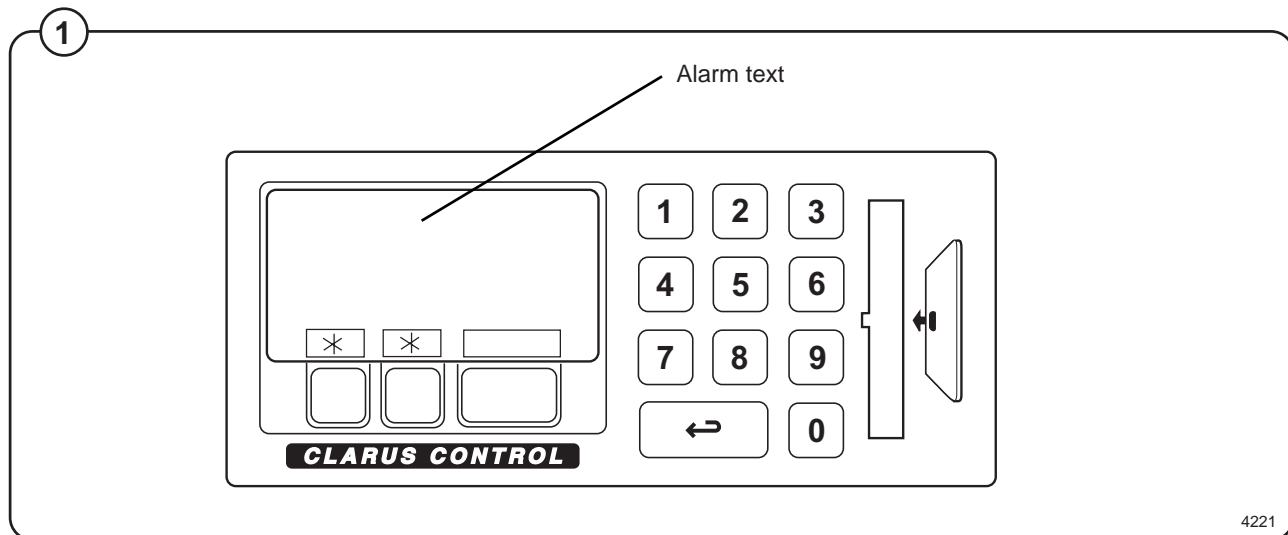

4221

Resetting an error indication

Error indications can be reset in two different ways:

- Fig. 1**
- By pressing START, the error may be temporarily reset. The machine then continues the programme that was already started. If the error code remains, the error will come back at once.
 - By pressing  the error is reset and the started programme is cancelled.

Error codes

A brief summary of all error codes and the possible cause for each error is presented below. Troubleshooting charts for all errors are presented on the following pages.

List of errors, functions monitored and relevant error messages displayed

Error/Function	Error message displayed
<p>01 ERROR. NO WATER Water level has not reached set level within time set. After this error message appears and the machine is reset, the machine will try again.</p>	NO WATER
<p>02 ERROR. OPEN DOOR Signal from microswitch which checks door status absent during program. After this error message appears and the machine is reset, the machine will try again.</p>	DOOR OPEN
<p>03 ERROR. DOOR LOCK Signal from microswitch which detects when the door is locked absent during program.</p>	DOOR UNLOCKED
<p>04 ERROR. LOW TEMPERATURE The temperature is below the lowest value allowed (open circuit in temperature sensor).</p>	NTC LOW TEMP
<p>05 ERROR. HIGH TEMPERATURE The temperature is above the highest value allowed (short-circuit in temperature sensor).</p>	NTC HIGH TEMP
<p>06 ERROR. WATER IN MACHINE The water level is higher than the level EMPTY at the start of the program.</p>	WATER IN DRUM
<p>07 ERROR. OVER-FILLED The water level is higher than the "LEVEL OVERFILL" (i.e. DRUM OVER-FILLED) level. If this function is switched off (=N), instead the drain valve will open for a short time and discharge some of the water. This is described under the function "DRAIN TIME WHEN OVERFILL" (i.e. DRAIN TIME AFTER OVER-FILLING) earlier in this section.</p>	MACHINE OVER-FILLED
<p>08 ERROR. NO HEAT The temperature has not increased by the number of degrees specified in the function "MIN. TEMPERATURE INCREASE" (see back in this section), over the period of time specified in the function MAXIMUM HEATING TIME (see "SETTINGS 1").</p>	NO HEATING
<p>10 ERROR. REMAINING WATER When the drain sequence has finished, the water level is still higher than the EMPTY level.</p>	NOT DRAINED
<p>11 ERROR. UNBALANCE SWITCH The unbalance switch is closed when the machine is starting on a drain sequence.</p>	UNBALANCE SENSOR FAULT
<p>13 ERROR. MOTOR COMMUNICATION Communication between PCU and motor control unit interrupted or disturbed.</p>	NO MOTOR COMM
<p>14 ERROR. LEVEL ADJUST Every machine has individual level calibration at the factory. If these calibration values are missing or fall outside the limit values, an error warning will be flagged at each program start-up. The program can still be started, however, by pressing START. It will then use standard (default) values, which means that the levels will not be as precise as intended.</p>	LEVEL CALIBRATION

List of errors, functions monitored and relevant error messages displayed, cont.

Error/Function	Error message displayed
15 ERROR. EMERGENCY STOP The emergency stop button has been pressed.	EMERGENCY STOP
16 ERROR. WEIGHT FROM SCALE Over-/Under-load of scale or weight above limit for maximum allowed weight at wash module start.	WEIGHT FROM SCALE
17 ERROR. DOOR LOCK SWITCH Even though the door lock microswitch indicates that the door is locked, the signal from the microswitch which is used to detect when the door is closed is absent.	DOOR LOCK
18 ERROR. START NOT ALLOWED Network does not allow programme start.	START NOT ALLOWED
19 ERROR. MIS COMMUNICATION Machine has lost contact with network.	MIS COMMUNICATION
20 ERROR. EWD INTERLOCK The motor control system for frequency-controlled motors (EWD) receives a signal direct from the door lock which indicates that the door really is closed. If this signal is lost, a fault signal is sent to the PCU	INTERLOCK STATUS
21 ERROR. I/O COMMUNICATION Communication between the CPU board and one of the I/O boards interrupted or disturbed.	I/O COMMUNICATION
22 ERROR. LOW OIL LEVEL In machines with an oil lubrication system, indicates low level in the oil container.	LOW OIL LEVEL
23 ERROR. LOW OR HIGH VOLTAGE Incorrect input voltage to external equipment.	PHASE
24 ERROR. PRESSURE SENSORS, TILT Both pressure sensors are active at the same time.	PRESSURE SENSOR TILT
25 ERROR. PRESSURE SENSOR TIMEOUT No pressure at the relevant pressure sensor within the maximum time allowed for tilt backwards or forwards.	PRESSURE SENSOR TIMEOUT
26 ERROR. DOOR SWITCH, TILT Door closed (S3) is "on" at a time when the machine door is locked open (S25).	DOOR SWITCH, TILT
27 ERROR. LEVEL OFFSET The pressure sensor for the water level signals a value that is so different from the empty machine state that the automatic level calibration cannot adjust the level system.	AUT. LEVEL CALIB.
28 ERROR. LEVEL NOT CALIBRATED Calibration of level system not done in service mode before use of machine.	

List of errors, functions monitored and relevant error messages displayed, cont.

Error/Function	Error message displayed
ERROR. ERROR CODES FROM MOTOR	
This function includes a number of error warnings from the motor control system for frequency-controlled motors (EWD)	
31 Temperature of MCU control circuits too high	HEAT SINK TOO HOT
32 Motor thermal protection has tripped	MOTOR TOO HOT
33 The motor has received a start command from the PCU without receiving an interlock signal from the door lock. The MCU receiving circuitry for the interlock signal is not faulty	NO INTERLOCK
35 Short-circuit between motor windings or to earth.	MOTOR SHORTNING
36 Fault in MCU receiving circuitry for lock acknowledgement signal.	INTERLOCK HARDWARE
37 DC voltage too low	LOW DC VOLTAGE
38 DC voltage too high	HIGH DC VOLTAGE
39 DC level varying too much	RIPPEL ON DC BUS
40 One phase missing for/at motor control unit	LINE INTERRUPT
41 Hardware fault, temperature monitoring, motor	KLIXON CIRCUITS

Service programme

Opening the service programme

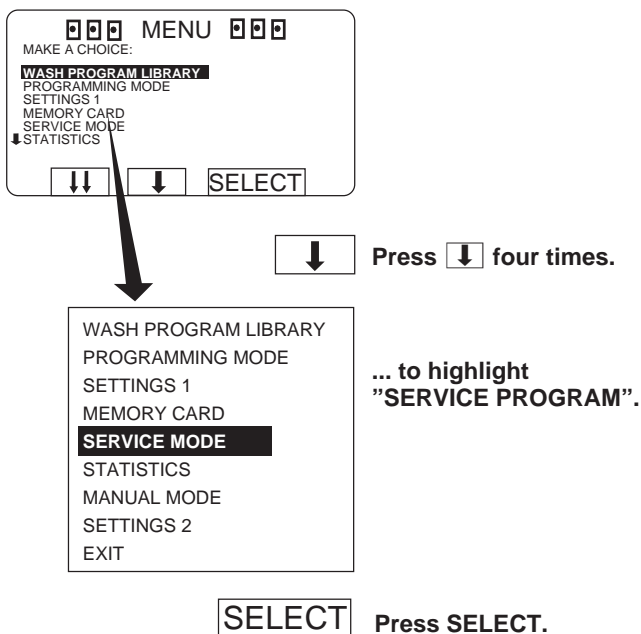
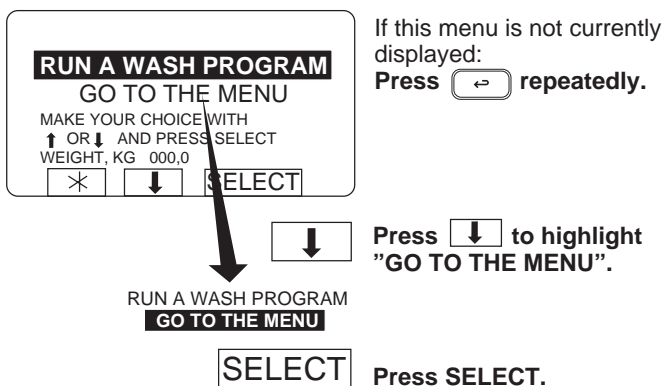

The service program

The service program makes fault-finding on the machine easier, as it allows you to control the various machine functions individually:

- water filling
- detergent flushing
- motor rotation, clockwise and counterclockwise
- motor action, distribution and extraction
- drain
- door lock
- heating
- buzzer

You can also check which input signals to the PCU are activated:

- emergency stop
- remote start
- oil lubrication
- service
- repeat rinse
- phase check
- door locked
- door closed
- imbalance

The following values will also be displayed at all times:

- water level in machine
- water temperature
- motor speed
- whether drain is open or closed

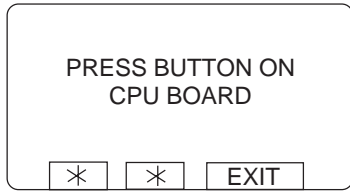

Not for Wascator FOM71 CLS.

Press the **button** on the CPU circuit board.

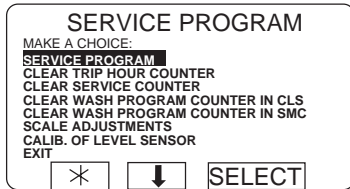

To access the service program:

SELECT

Press **Select**.

To prevent unauthorised or accidental use
 Unauthorised or accidental use of the service program is prevented by requiring the user to locate and press the button on CPU board.

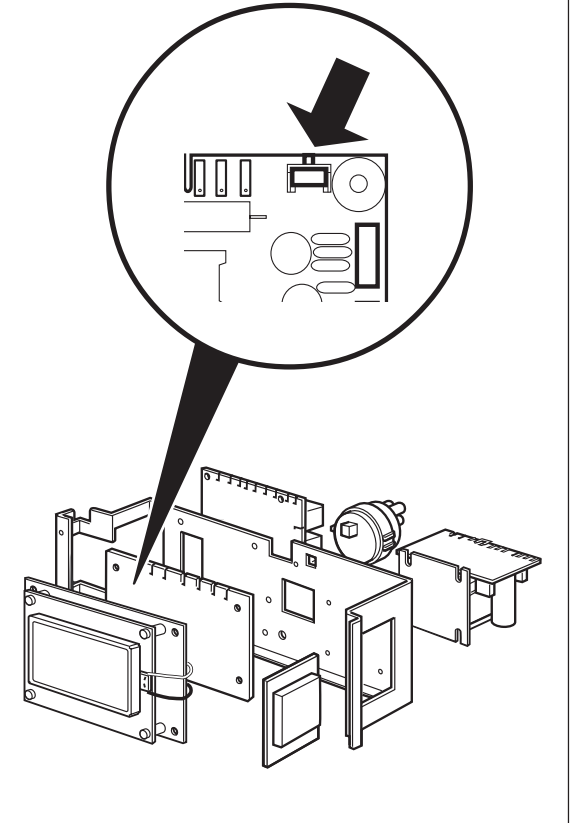

To control the machine functions

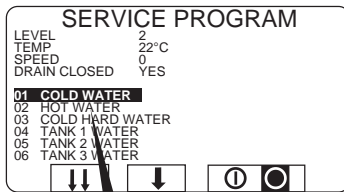

01 COLD WATER
02 HOT WATER
03 COLD HARD WATER
04 TANK 1 WATER
05 TANK 2 WATER
06 TANK 3 WATER
07 FLUSH
10 DETERGENT POWDER 1
11 DETERGENT POWDER 2
12 DETERGENT POWDER 3
13 DETERGENT POWDER 4
14 DETERGENT POWDER 5
17 LIQUID DETERGENT 1
18 LIQUID DETERGENT 2
19 LIQUID DETERGENT 3
20 LIQUID DETERGENT 4
21 LIQUID DETERGENT 5
22 LIQUID DETERGENT 6
23 LIQUID DETERGENT 7
24 LIQUID DETERGENT 8
25 LIQUID DETERGENT 9
26 LIQUID DETERGENT 10
27 LIQUID DETERGENT 11
28 LIQUID DETERGENT 12
29 LIQUID DETERGENT 13
33 MOTOR CLOCKWISE
34 MOTOR COUNTERCLOCKWISE
35 DISTRIBUTION
36 LOW EXTRACT
37 MEDIUM EXTRACT
38 HIGH EXTRACT
39 TURBO EXTRACT
40 NORMAL DRAIN
41 DRAIN BLOCKING
42 RECYCLE DRAIN A
43 RECYCLE DRAIN B
44 RECYCLE DRAIN C
45 RECYCLE DRAIN D
49 OIL (PULS)
51 DOOR LOCK
55 HEAT
56 HEAT 2 AS STANDARD
64 BUZZER
EXIT

To activate the various machine functions:

Use or to highlight the function.
Press to switch the function on and off.

I/O card inputs

1 Press 1.

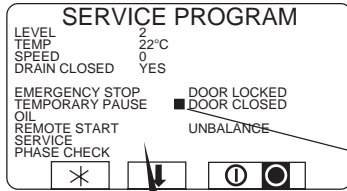

Now you can check the various input signals from I/O board 1.

A black square in front of the name indicates that the input is active.

I/O-BOARD 1

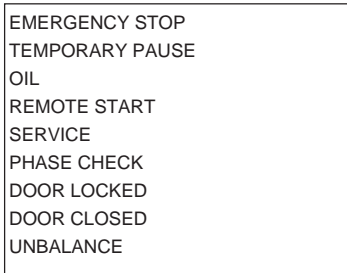

Press any key to go back to the previous display.

When the programme unit has two I/O cards:

2 Press 2.

I/O-BOARD 2

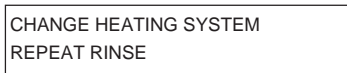

It is now possible to verify the various input signals from I/O card 2.

Press any key to go back to the previous display.

To end the service programme

End the service programme by pressing .

Errors with no error codes

No indication in the display window (machine not responding or operates apart from this).

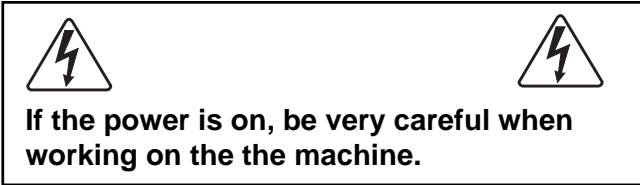

Verify that:

- the machine receives power.
- the machine has not been emergency stopped.
- the red LEDs on the programme unit card and the I/O card light steadily. (Verify through measurement that X3:1 - 2 at A11 is 16 V. If not, troubleshoot the voltage supply circuit.)
- verify that the green LEDs on the programme unit card and the I/O card blink quickly.
- verify the fuses F11 and F12 (T 1.25 A) on the communication card A21. Replace burnt-out fuses.

Fig. 2

Fig. 3

Fig. 4

1. Perform a communication test using the test box. Refer to the manual "Instructions for Clarus Communication Tests".

OK LED on test box

Defective LEDs on test box

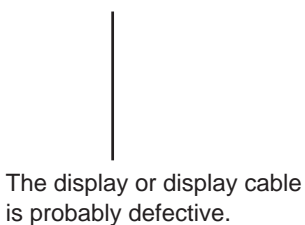

Troubleshoot according to the manual "Instructions for Clarus Communication Tests".

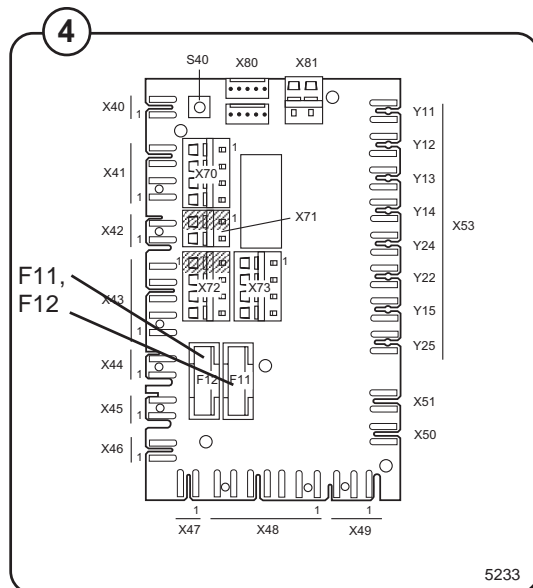
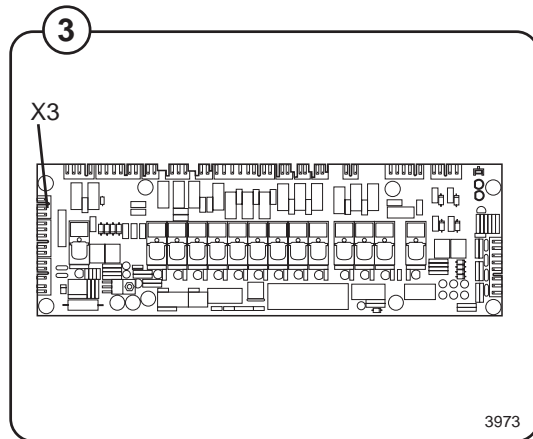
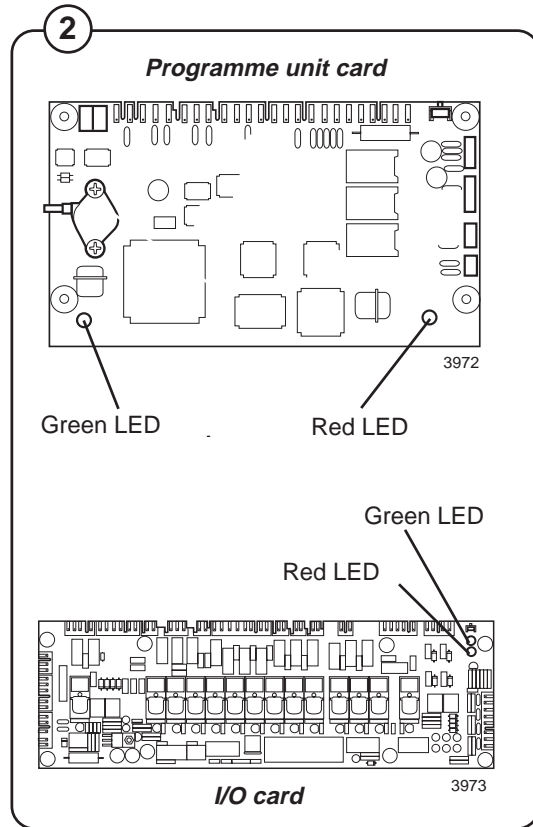

Errors with error codes

NO WATER

The water level has not reached the selected level within the given time. Following an alarm and subsequent, the machine will make a new attempt.

First verify that:

- the programme unit was not incorrectly programmed
- the inlet filter is not blocked
- all water faucets are open
- the drain is not leaking
- Reset the error code. Continue with troubleshooting if the error code appears again.

5

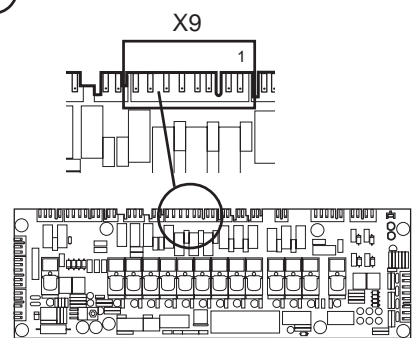

X9

1

3973

Valve	Switch	Relay
Y11 cold/warm compartment 1	X9:7	4
Y12 cold/warm compartment 2	X9:6	5
Y13 cold/warm compartment 3	X9:5	6
Y15 cold mix box	X9:4	7
Y22 warm compartment 2	X9:2	8
Y25 warm mix box	X9:1	9
Y14/24 cold/warm compartment 4	X9:3	10

Fig. 5 1. Enter the service programme and the activate water valves on the machine, one after the other.

All valves fill up with water One of the valves does not fill up with water

2. Activate the defective valve in the service programme and measure the voltage (230 V) at the water valve.

No voltage

Voltage OK

The valve is probably defective. Verify and remedy

Fig. 5 3. Depending on the valve, measure the supply voltage (230 V) of the water valve at switch X9 on I/O card 1, A11. The relay functions can also be verified using the LEDs on I/O card 1.

No voltage

Voltage OK

Defective cables between the communication card A11 and the water valve, or defective programme unit card A1. Verify and remedy.

Probably defective control output from the programme unit card A1 or I/O card 1 A11.

Continued on next page

Continued from previous page

5. Activate (close) the drain valve in the service programme. Activate another of the water valves and verify the drain valve function.

Drain valve OK

Drain valve defective

Troubleshoot the drain valve according to the instructions under error code **WATER IN DRUM** later in this troubleshooting section.

Fig.

6

6. Verify that the level hose is not damaged, bent, blocked and has not come loose from the T-joint, drum, programme unit card A1 or level guard B2.

Level hose OK

Defective level hose

Fit the hose correctly or replace it.

Fig.

7

Level detector on programme unit card A1 probably defective.

- Enter the service programme and verify that the level indication is stable.
- Blow into the level hose and check the level indication increases.
- Check the level system for leakage.

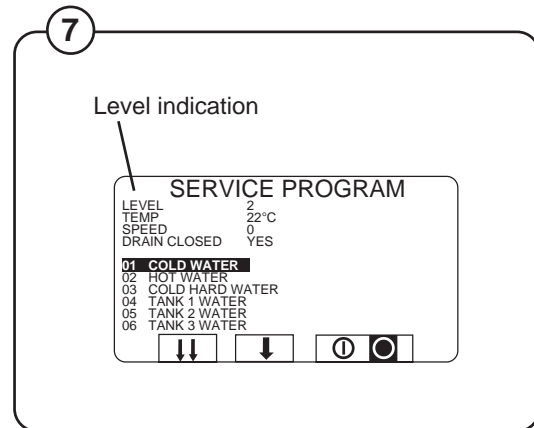
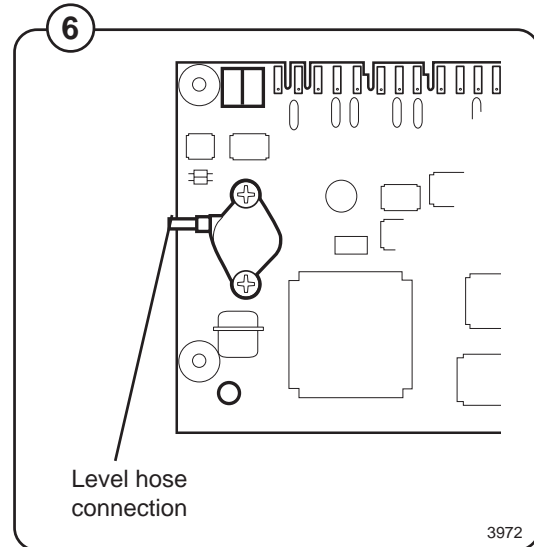

DOOR OPEN

No signal from the "Door closed" during programme operation. If the input signal for "Door closed" is lost during programme operation, the OPEN DOOR error code is immediately generated.

If the power is on, be very careful when working on the the machine.

1. Try to restart the machine (i.e. reset the error code) by pressing START.

Error message returns

No error message

Temporary error (probably defective contact)

Fig. 8

2. Exit the programme using . Enter the service programme (unlock the door if it is locked). Verify voltage supply is present between X5:4 - 5 when the door is closed.

Fig. 9

No voltage

Voltage present but black square does not light

I/O card 1 A11 probably defective.

3. Verify voltage is present between X5:3 - 5.

Voltage present

No voltage

Troubleshoot the cabling for the voltage supply (between the main power switch Q1 and X6).

Continued on next page

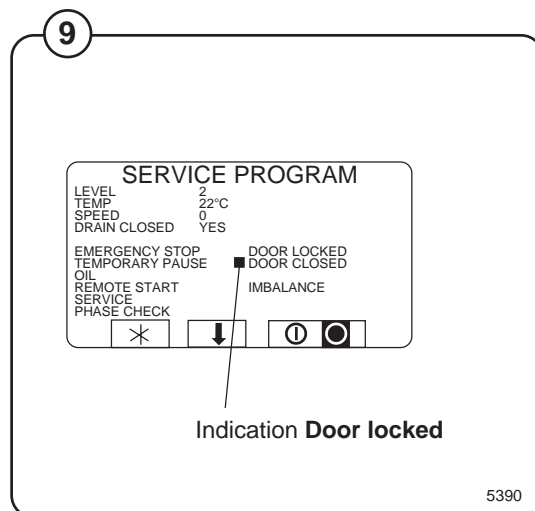
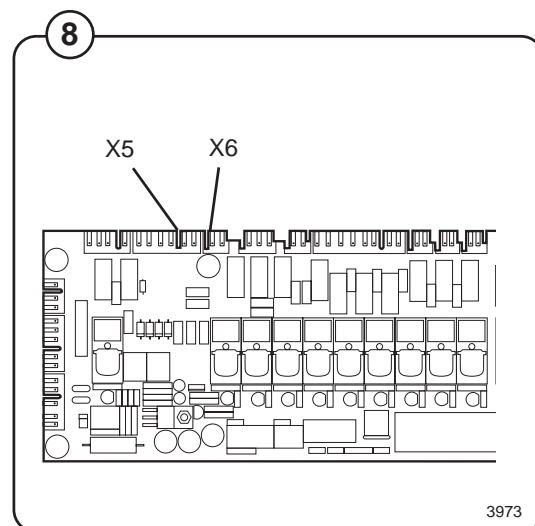

Continued from previous page

Fig. 10 4. Disassemble the door lock and verify the function of S3 using an ohm meter.

Correct function

Incorrect function

Replace S3./Change door lock.

5. Inspect the cabling between X5 and S3 using an ohm meter.

Cabling OK

Incorrect cabling

Remedy or replace the cables.

Inspect the mechanical function of the door lock.
Replace any defective components or replace the door lock.

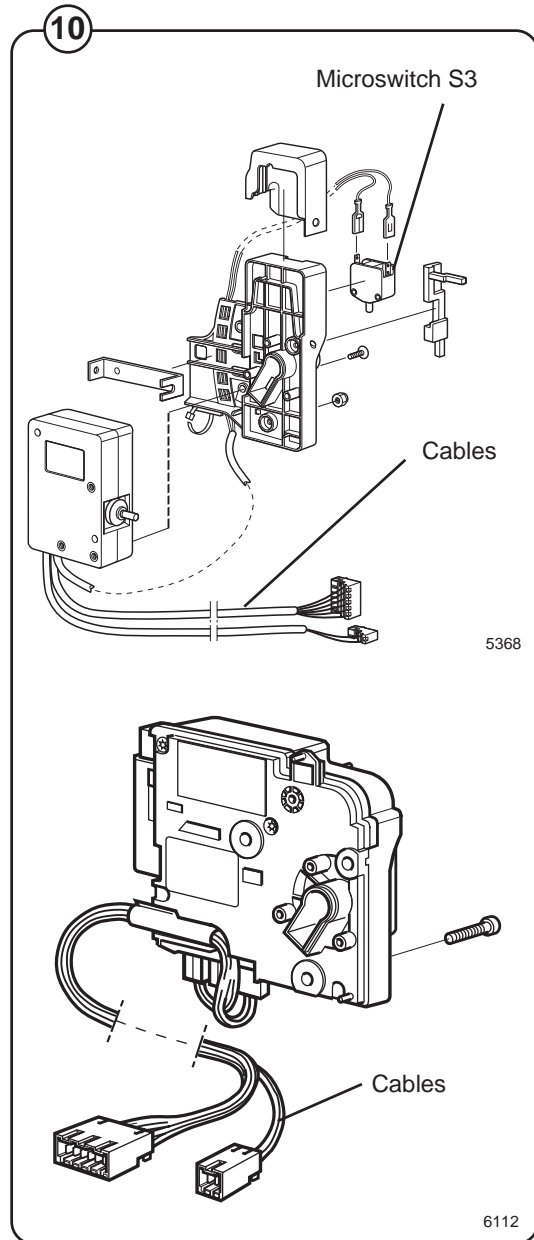

DOOR UNLOCKED

No signal from the "Door locked" during programme operation.

If the input signal for the "Door locked" is lost during programme operation, the "DOOR UNLOCKED" error code is immediately generated.

At programme start, this error code is suppressed for a few seconds.

If the power is on, be very careful when working on the the machine.

1. Try to restart the machine (i.e. reset the error code) by pressing START.

Error message returns

No error message

Temporary error in the door lock or programme unit

Fig. 11 2. Exit the programme using . Enter the service programme and verify that there is voltage between X5:2 - 6 when the door lock is engaged.

Fig. 12 *No voltage*

Voltage present but black square does not light

I/O card 1 A11 probably defective

3. Verify that there is voltage supply between X5:1 - 5 when the door lock is switched on.

Voltage present

No voltage

Troubleshoot the cabling for the voltage supply (between the main power switch Q1 and X6).

Fig. 13 4. Is the lock command present? Measure X:92 on the door lock controller.

Yes

No

Troubleshoot according to the error codes in section 29.

Troubleshoot cabling between X5 and the actuator/door lock. The actuator/door lock could be defective.

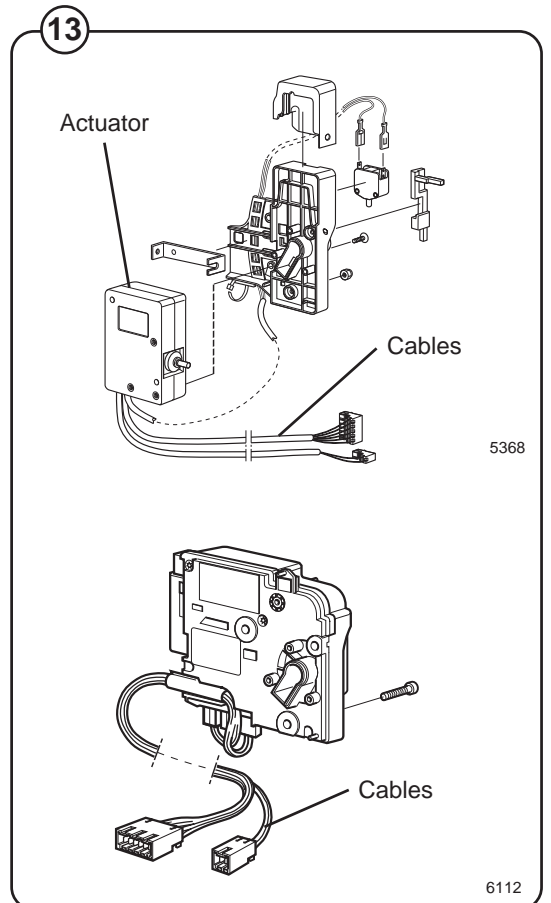
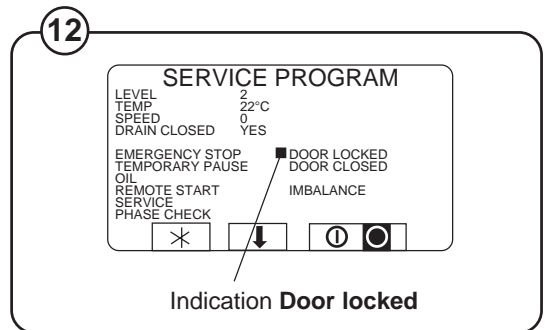
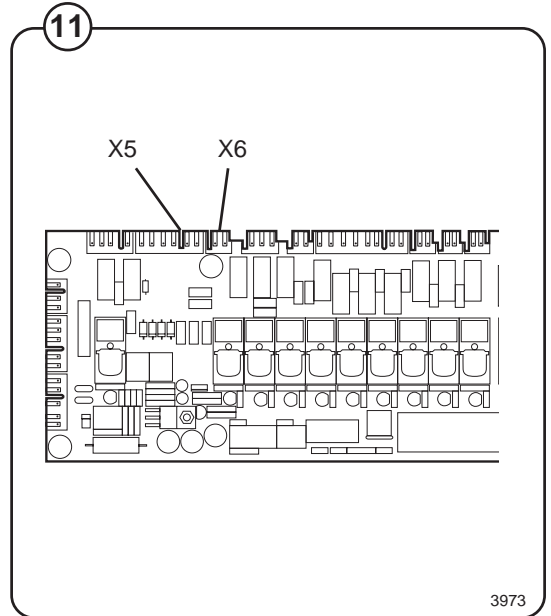

NTC LOW TEMP

The programme unit indicates an interruption with the temperature sensor or the temperature is below -5 °C.

Try to restart the machine (i.e. reset the error code) by pressing START.

Fig. 14 1. Undo the temperature sensor connections and measure the resistance of the sensor. The resistance should be as in the table below:

Approximate values for a fully functional temperature sensor

T (°C)	R (ohm)
19	6109
20	5844
21	5592
22	5353
23	5124

Resistance OK

Incorrect resistance

The temperature sensor is probably defective.

Fig. 15 2. Exit the programme using . Enter the service programme and read the temperature (the display window shows 0°C). Short-circuit inputs 1 and 2 on card switch X1. Verify that the display window shows 100°C.

Yes

No

Incorrect temperature sensing on the programme unit card. Replace the card.

Incorrect cabling to the . Verify and replace if necessary.

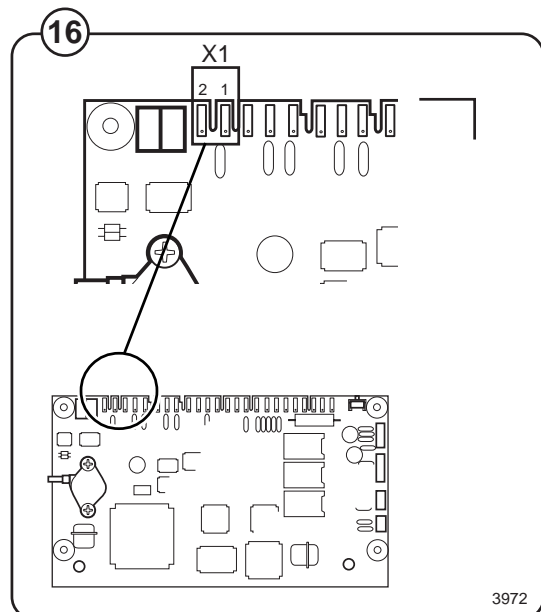
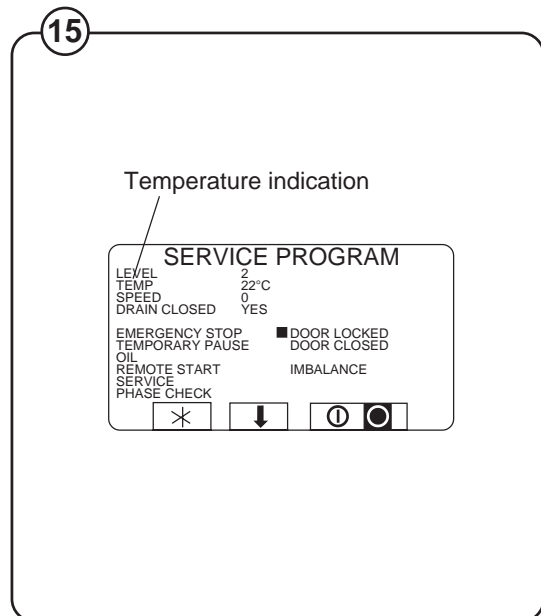
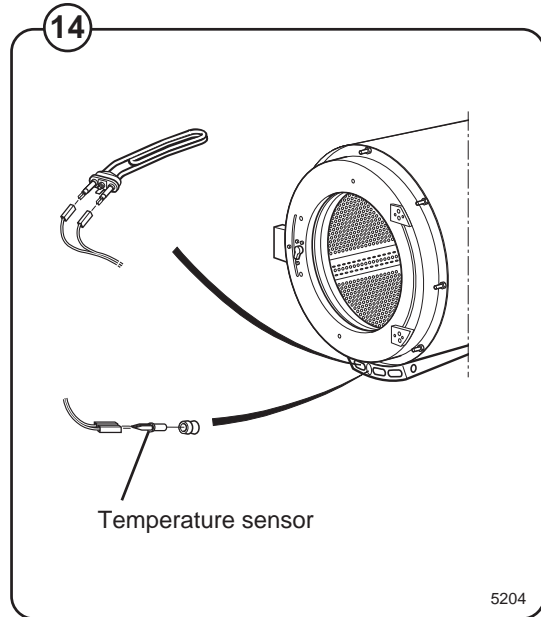

NTC HIGH TEMP

The programme unit indicates a short-circuit with the temperature sensor or the temperature exceeds 98°C.

Try to restart the machine (i.e. reset the error code) by pressing START.

Fig. 17 1. Undo the temperature sensor connections and measure the resistance of the sensor. The resistance should be as in the table below:

Approximate values for a fully functional temperature sensor

T (°C)	R (ohm)
19	6109
20	5844
21	5592
22	5353
23	5124

Resistance OK

Incorrect resistance

The temperature sensor is probably defective.

Fig. 18 2. Reset the connection on the sensor and exit the programme using . Enter the service programme and read the temperature. Disconnect one of the inputs 1 and 2 on card switch X1. Verify that the display window shows 0°C.

Yes

No

Incorrect temperature sensing on the programme unit card.

Incorrect cabling to the temperature sensor. Verify and replace if necessary.

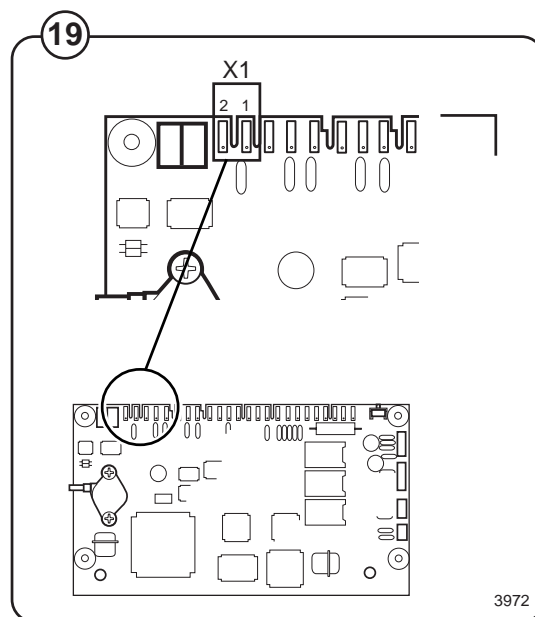
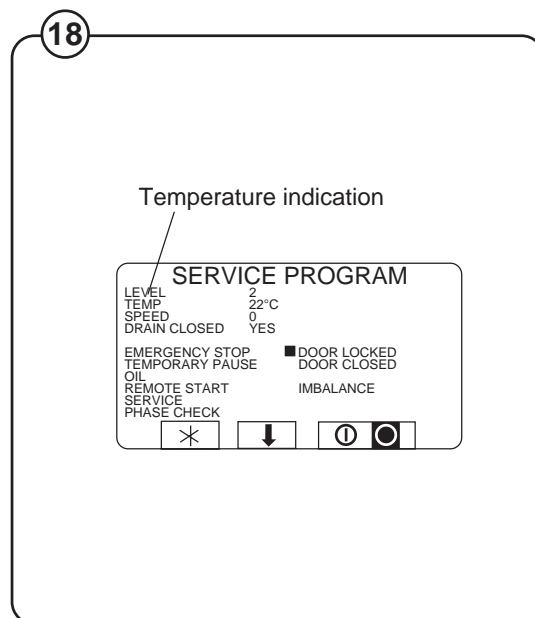
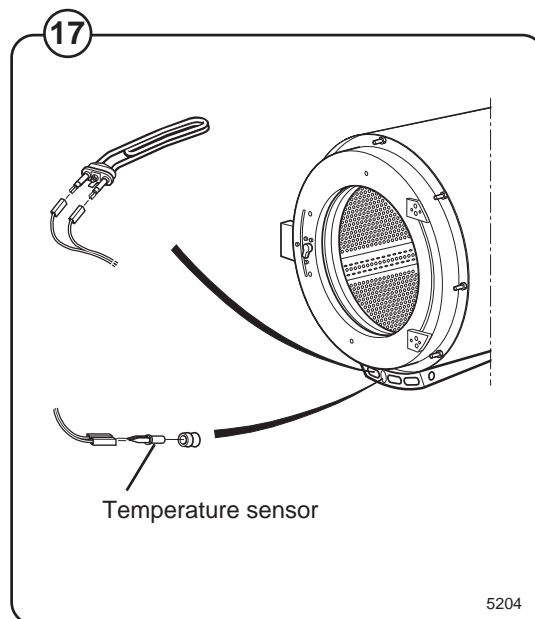

WATER IN DRUM

The water level is higher than **EMPTY** at programme start.

First verify whether:

- the same error appears again following resetting of the error code
- the drain is blocked by fluff or foam
- the level hose and air box are blocked (blow into the level hose)
- For machines with a drain pump, verify correction operation.

Pay attention to temperature extremes in the surrounding which may affect the level system, generating this error code.

1. Verify whether there is any water in the drum.

Water in drum *No water in drum*

2. Enter the service program and record the actual level value. Disconnect the level hose from the programme unit card A1.

Level value does not change *Level value falls*

The level hose is probably blocked by fluff or due to incorrect installation. Verify and clean, or replace the hose.

Level detector on programme unit card A1 is defective.

Verify the operation of the drain valve using the service programme. Remedy or replace the defective drain valve if necessary.

Fig. 20
Fig. 21

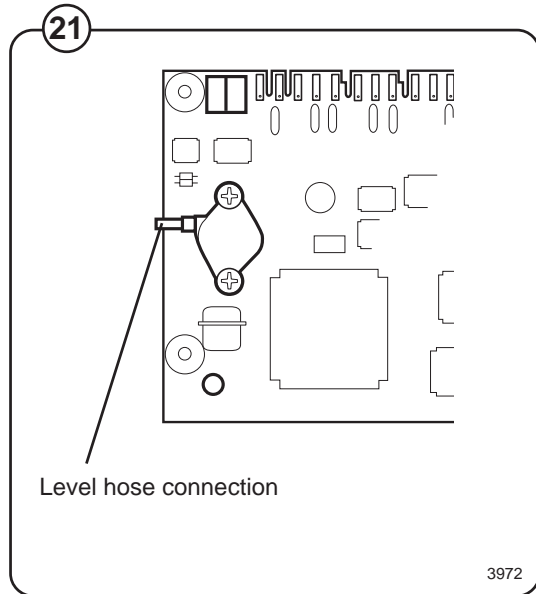
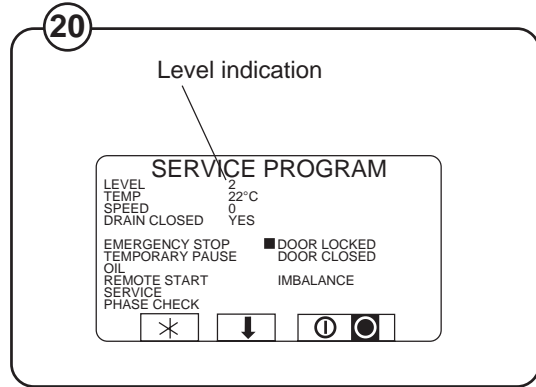

3972

MACHINE OVERFILLED

The water level is above the level for OVERFILLED MACHINE. If this function is switched off (=N) the drain valve will open instead for a short while to drain some of the water.

If the power is on, be very careful when working on the the machine.

Try to restart the machine (i.e. reset the error code) by pressing START.

If the error returns, first make sure that:

- the level hose and air box are not blocked (blow into the level hose)
- that none of the water valves has locked (i.e. poured in continuously).

1. Visually inspect. Is there too much water in the machine?

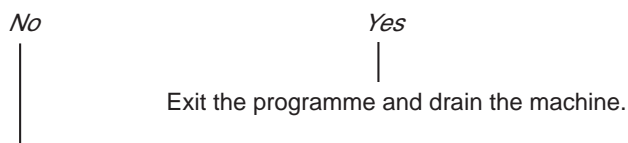
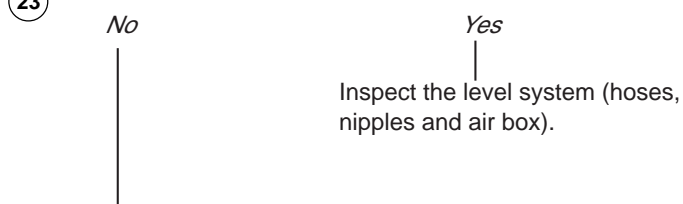
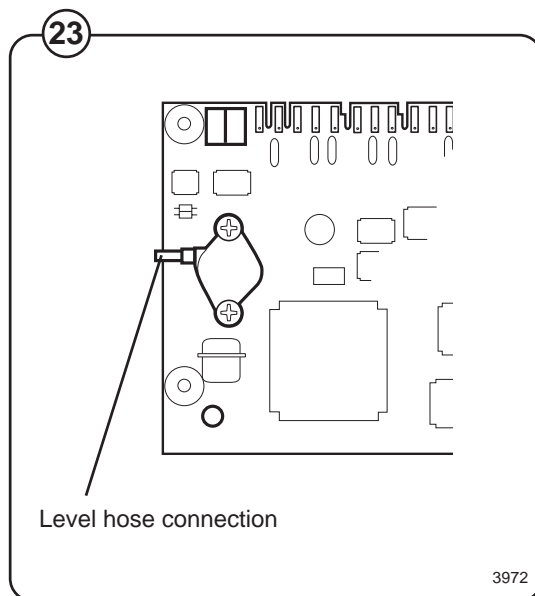
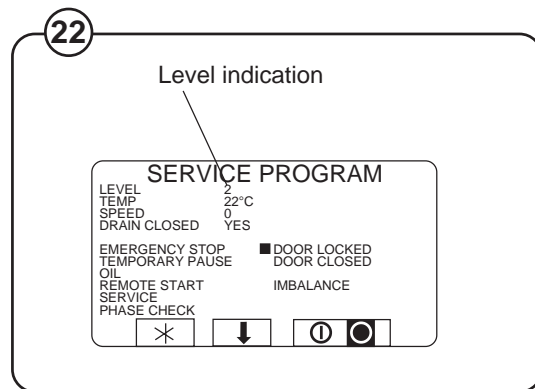

Fig. 22. Exit the programme using . Enter the service programme and record the actual level value. Undo the level hose from the programme unit and verify whether the level falls.





3. Inspect whether the level input on the programme unit is blocked. If this is not the case, the the programme unit is probably defective.



NO HEATING

The temperature has not increased the number of degrees specified in the function **MIN ALLOWABLE TEMPERATURE INCREASE** (see settings 2) during the time that is programmed in the function **MAXIMUM HEATING TIME** (Configuration 1).





If the power is on, be very careful when working on the the machine.

Try to restart the machine (i.e. reset the error code) by pressing **START**.

If the error returns, first make sure that:

- the programme module is not incorrectly programmed
- the heat supply is intact (all phases OK and the steam or gas boiler is operating)
- the drain does not leak.

1. Exit the programme using . Enter the service programme and fill up water to above the safety level (5-10 cm above the lower edge of the inner drum). Switch on the heating. Does the heat contactor go high?

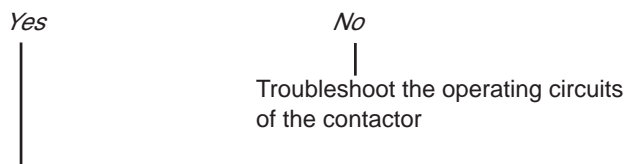
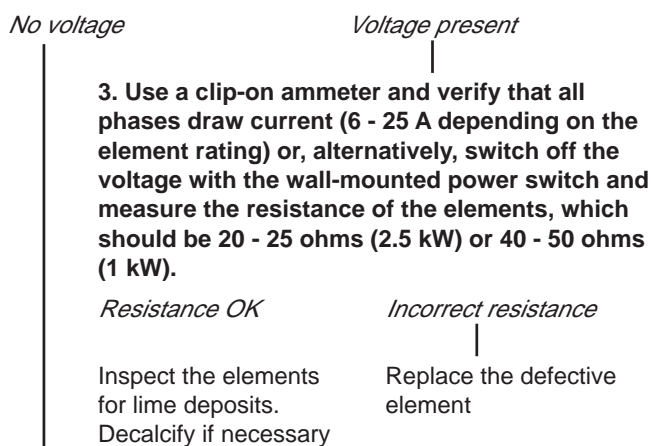
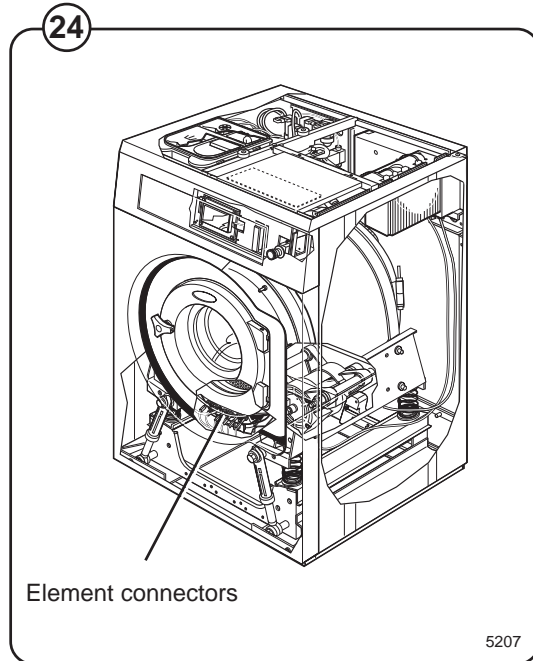

Fig. 24 2. Measure the operating voltage across each element.



4. Troubleshoot the voltage supply circuit for the elements.



NOT DRAINED

The water level exceeds EMPTY at wash program start.

Try to restart the machine (i.e. reset the error code) by pressing START. If the error returns, first verify these items:

- Is the drain is blocked by fluff or foam?
- Are the the level hose and air box blocked (blow into the level hose)?
- For machines with a drain pump, verify correction operation.
- Does water run out when the power switch on the machine is switched off?
- Verify the operation of the drain using the service programme.
- Is the drain in the room capable of receiving the water from the machine?

UNBALANCE SENSOR FAULT

The imbalance switch is closed during program start.



If the power is on, be very careful when working on the the machine.

Try to restart the machine (i.e. reset the error code) by pressing START. If the error returns, troubleshoot as follows:

Verify:

- the mechanical function of the imbalance switch
- the resistance between the imbalance switch and the cabling.

If the error remains, there is probably an internal error in the motor controller.

NO MOTOR COMM.

Communication between the programme unit and the motor controller has been interrupted or interfered.



If the power is on, be very careful when working on the the machine.

Try to restart the machine (i.e. reset the error code) by pressing START. If the error returns, troubleshoot as follows:

1. Perform a communication test using the test box. Refer to the manual "Instructions for Clarus Communication Tests".

OK LED on test box



Defective LEDs on test box



Troubleshoot according to the manual "Instructions for Clarus Communication Tests".

The motor controller or cabling for the motor controller is probably defective.

LEVEL CALIBRATION

The water level system has not been correctly calibrated.

Each machine has been individually level adjusted at the factory. If the calibration values are missing or outside the limits, an error is generated at programme start. The programme can, however, be started by pressing START once more. In this case the standard values are used and the level will not be as exact.

Carry out programming anew and make sure the calibration values are within the allowed limits.

WEIGHT FROM SCALE

The scale is all the time sending the actual weight to the timer. If the scale is over- or under-loaded all the time the error will be indicated.

The same error will also be indicated if the weight transferred from the scale to the timer at the beginning of a water filling periode, is above a certain limit set in the configuration system of the machine. To correct the problem, try to first zero-calibrate the scale and then reset the scale in the servicemode. If the error remains, please contact service.

EMERGENCY STOP

The emergency stop button was pressed.



If the power is on, be very careful when working on the the machine.

Find out the reason for the emergency stop button having been pressed.

Take the necessary measures.



Reset the emergency stop button by turning it counter-clockwise.

Restart the machine by pressing START or .

DOOR LOCK

The signal from the "Door locked" switch is present although there is no signal from the "Door closed" switch.

This error code can only be generated prior to programme start.

If the power is on, be very careful when working on the the machine.

Try to restart the machine (i.e. reset the error code) by pressing START.
If the error returns, troubleshoot as follows:

Fig. 25 1. Undo the card connection X5 on I/O card 1, A11

Error message returns

No error message

Fig. 26

I/O card A11 probably defective.

Troubleshoot the door lock and the cabling for electric or mechanical short-circuit.

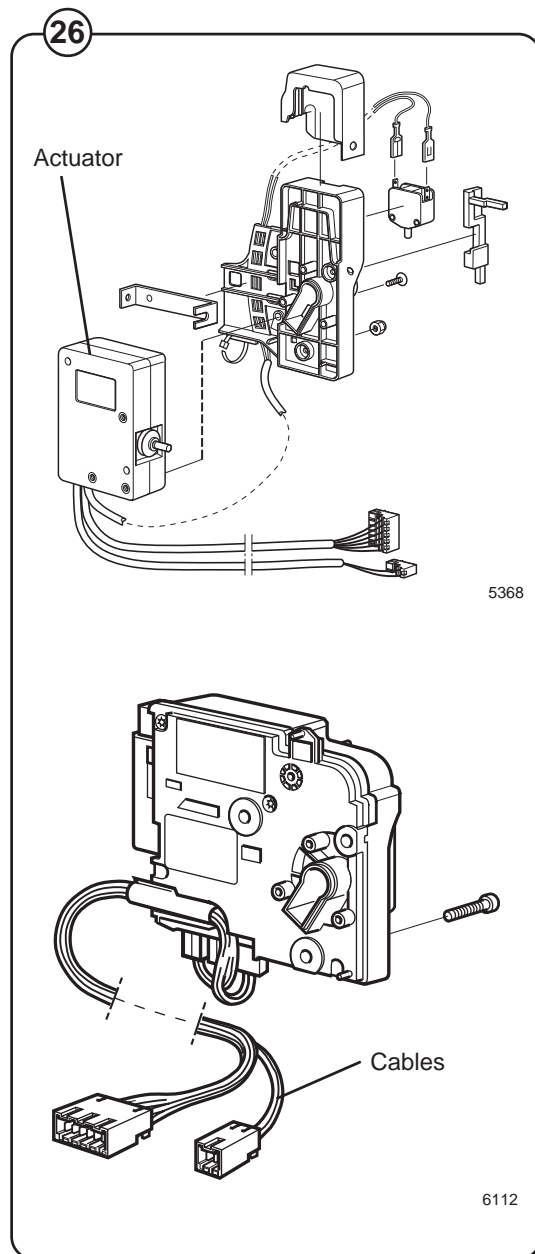
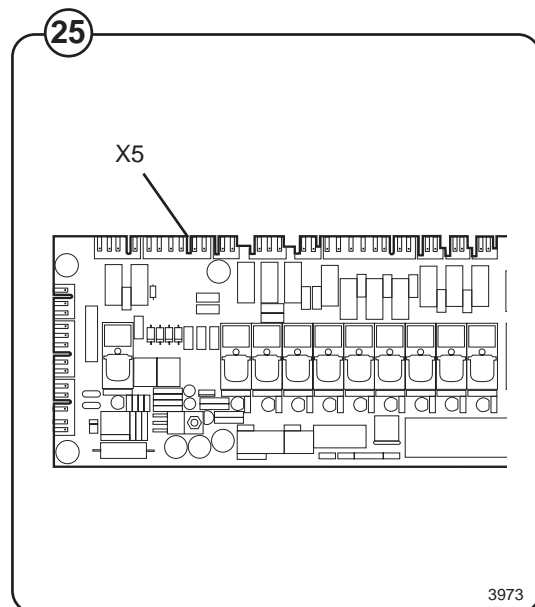

START NOT ALLOWED

The network does not allow start of the washing programme.

Try to reset the error code.

If the error remains, contact the responsible person for the network and have the error fixed.

MIS COMMUNICATION

Communication between the programme unit card A1 and the network has been interrupted.



If the power is on, be very careful when working on the the machine.

Try to restart the machine (i.e. reset the error code) by pressing START.

If the error returns, troubleshoot as follows:

Fig.
27

Verify that the cable between the network and X7 on programme unit card A1 is connected. If the cable is properly connected, contact the person responsible for the network.

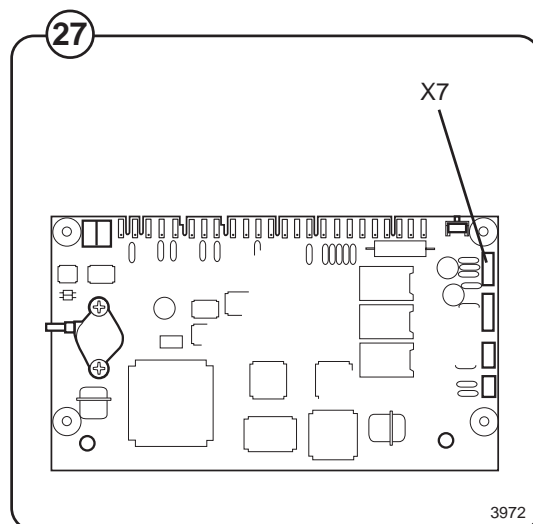

Note!

This error code will disappear by itself after several programme starts. In case communication has been interrupted intentionally, the machine can be operated with no further intervention required.



INTERLOCK STATUS

The motor controller does not receiving an interlock signal during programme operation.

If the power is on, be very careful when working on the the machine.

Switch off the machine for at least 30 seconds to ensure the motor controller has been completely reset. Then try to start the machine again. If the error returns, troubleshoot as follows:

Fig. 28 1. Measure the interlock signal on the motor controller U1:X302.

No signal

Signal OK

Troubleshoot the motor controller.

Fig. 29 2. Measure the signal on the I/O card 1 interlock bus A11:X10.

No signal

Signal OK

Troubleshoot the cabling between the motor controller and programme unit. Inspect the cabling and replace if necessary.

Troubleshoot the interlock circuits.

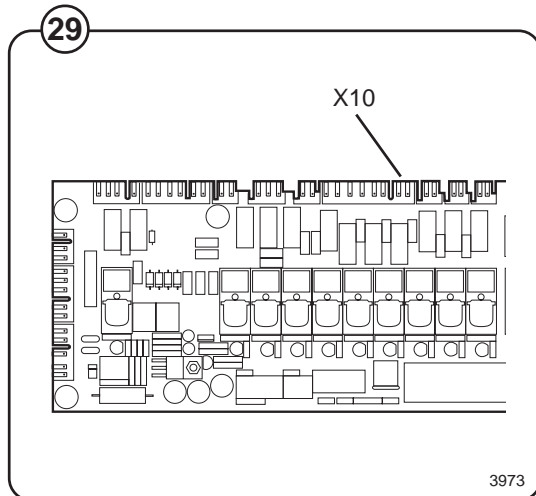
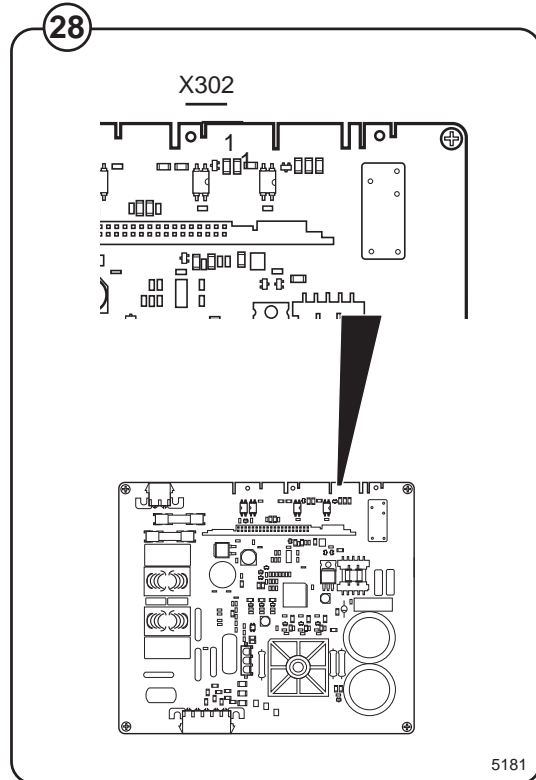

IO COMMUNICATION

Communication between programme unit A1 and one of the I/O cards has been interfered with or interrupted, or incorrect configuration of the I/O cards.



If the power is on, be very careful when working on the the machine.

Try to restart the machine (i.e. reset the error code) by pressing START. If the error returns, troubleshoot as follows:

1. Perform a communication test using the test box. Refer to the manual "Instructions for Clarus Communication Tests".

OK LED on test box



Defective LEDs on test box



Troubleshoot according to the manual "Instructions for Clarus Communication Tests".

The motor controller or cabling for the motor controller is probably defective.

LOW OIL LEVEL

Low oil level in the oil container. Applies only to machines with oil lubrication.

Fill up with oil and restart the machine.

Verify for any leaks.

PHASE

Alarm from the mains monitoring equipment.

An input on I/O card 1 (X16:7-8) can be connected to external equipment that monitors received mains signals in terms of voltage levels, loss of phase, etc. If this input goes high, the error message is displayed.

Find out the reason for the error indication by inspecting the mains monitoring equipment.

For more on this troubleshooting, refer to the manual supplied with the mains monitoring equipment in use.

AUT. LEVEL CALIB.

The pressure sensor for the water level signals a value that is so incorrect when the machine is empty that automatic level calibration of the level system is not possible.

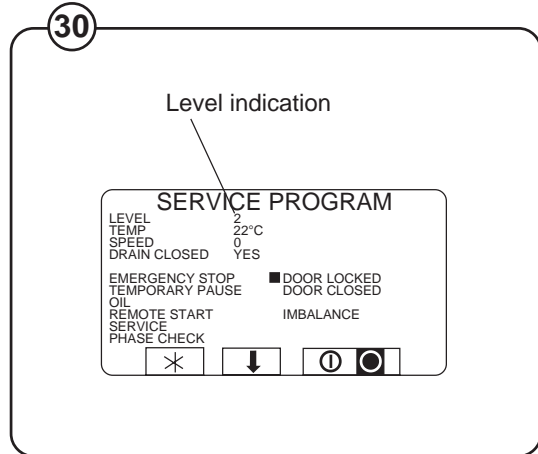
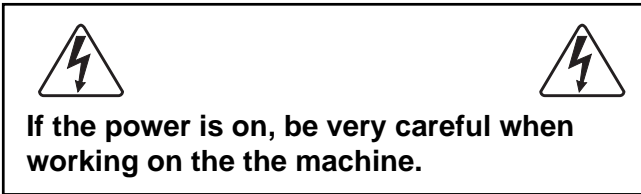

Try to restart the machine (i.e. reset the error code) by pressing START.
If the error returns, troubleshoot as follows:

Fig. 30 1. Verify the level indication in the service programme when the drum is empty. Does the level indication exceed the set limit value?

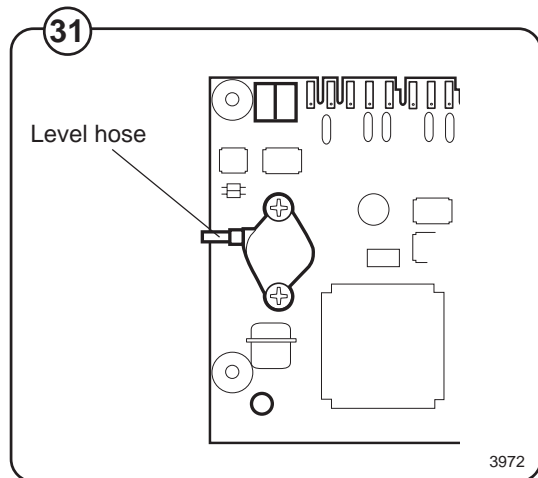
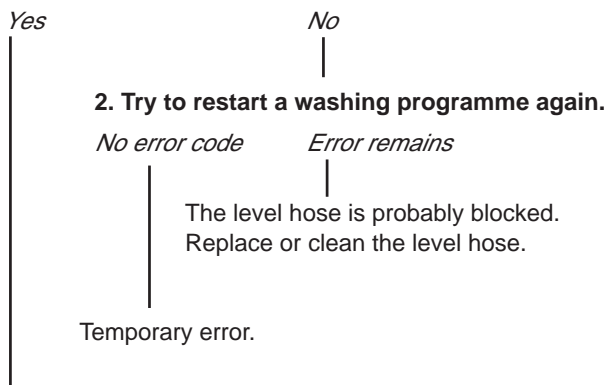
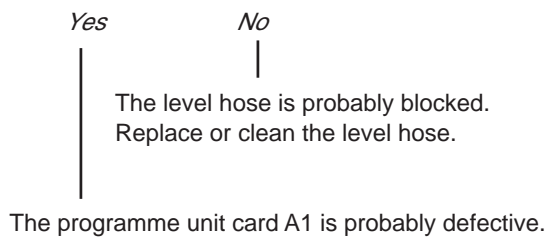

Fig. 31 3. Undo the level hose from the programme unit card A1. Does the level indication still exceed the set limit value?



LEVEL NOT CALIBRATED

Before the machine is used filling water controlled by the pressure sensor system, the pressure sensor system must be calibrated. The pressure sensor system for water filling can be calibrated in the service mode.

It is possible to use the machine in weight mode, filling water on weight, without calibrating the water pressure sensor system.

NO SCALE CONNECTED

Communication between the timer and the scale is not working. Check the wire between the timer and the scale. If still not working, please contact service.

HEAT SINK TOO HOT

The motor controller indicates too high a temperature at the heat dissipator.

This error code appears if the external temperature has been very high. It has been the case, lower the temperature by e.g., ventilation the room.



If the power is on, be very careful when working on the the machine.

First verify that:

- the machine is not overloaded
- the machine is not covered
- any fan for the motor controller operates correctly
- the motor controller heat dissipator is not blocked by dust
- the motor controller LEDs do not indicate an error (see the description of the motor controller in section 30).

Switch off the machine for at least 30 seconds to ensure the motor controller has been completely reset. Then try to start the machine again. If the error returns, troubleshoot as follows:

1. Verify that the drum and motor operate smoothly.

Drum/motor OK

Heavy operation of the drum/motor



Defective bearings in drum or motor, or there is an object between the outer and inner drum. Inspect and remedy.

2. Enter the service programme. Run the motor at different washing revolutions, clockwise and counter-clockwise. Verify that no noise can be heard from the drum/motor.

Drum/motor OK

Noise from drum/motor



Defective bearings in drum or motor, or there is an object between the outer and inner drum. Inspect and remedy.

The motor controller is probably defective.

MOTOR TOO HOT

The motor controller indicates the thermal protector of the motor has triggered.



If the power is on, be very careful when working on the the machine.



First verify that:

- the machine is not overloaded
- the ventilation openings of the machine are blocked
- the external temperature is very high
- the motor is not abnormally warm.

Switch off the machine for at least 30 seconds to ensure the motor controller has been completely reset. Then try to start the machine again. If the error returns, troubleshoot as follows:

1. Switch off the machine and verify that the drum and motor operate smoothly.

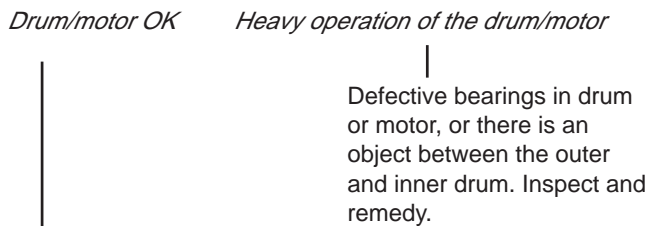

2. Wait for at least 10 minutes to allow the motor to cool down. Then switch on the machine again. Enter the service programme and run the motor at low washing revolutions. Verify whether the error indication immediately returns.

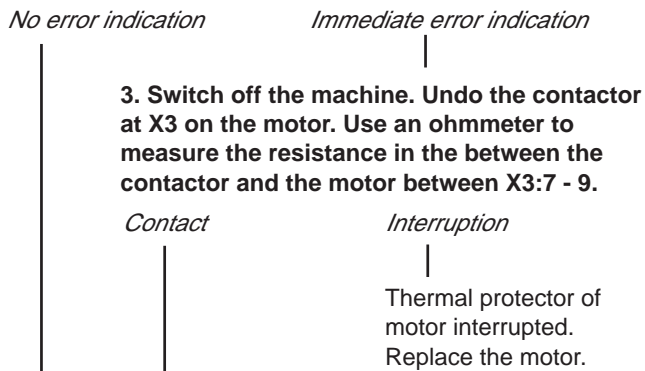
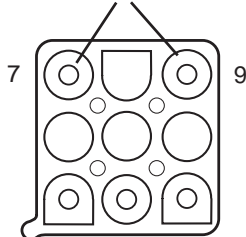

Fig. 32

32

Measure the resistance between pins 7 and 9



Contactor X3, female towards motor

5420

Continued on next page

Continued from previous

Fig. 33

4. Replace X3. Remove the contactor X312 and measure the resistance of the contactor with the motor cabling between X312:4 - 5.

Contact

Interruption

Defective cabling between motor controller and motor. Inspect the cabling and replace if necessary.

Internal error in the thermal sensor of the motor controller detector.

Fig. 34

5. Switch of the wall-mounted power switch. Undo the contactor at X3 on the motor. Use an ohmmeter to measure the resistance towards the motor. Measure between 1-2, 1-3, and 2-3.

Resistance

W365H	4 ohm
W375H	4 ohm
W3105H	4 ohm
W3130H	2 ohm
W3180H	1,2 ohm
W3240H	0,8 ohm
W3300H	0,8 ohm

Correct resistance

One of the resistance values is incorrect

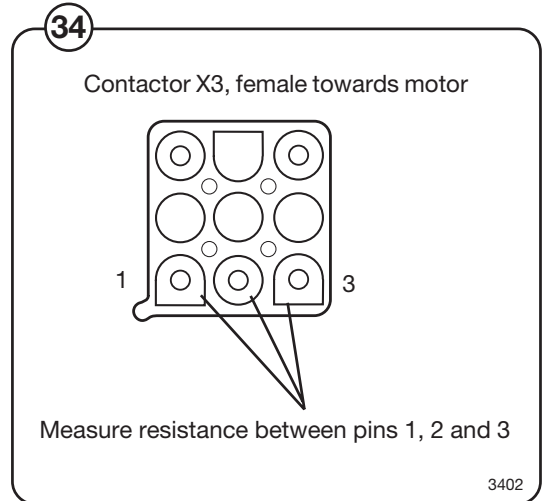
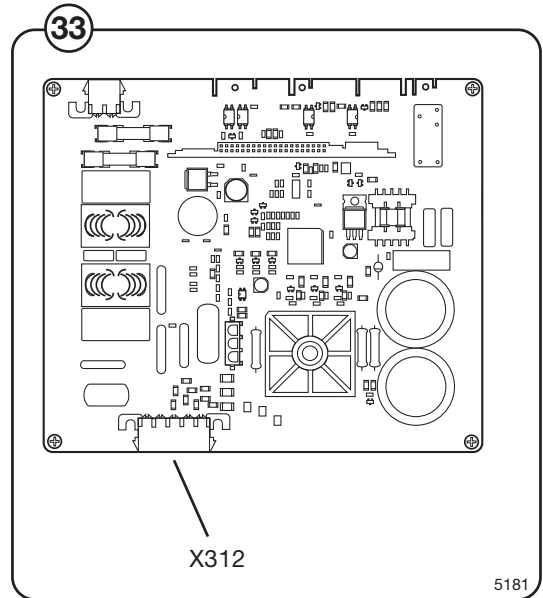

The motor is probably defective.

Troubleshoot the cabling between the motor and motor controller.



NO INTERLOCK

The motor controller received the rotation command from the programme unit but receives no interlock ACK ("Door locked" signal).

If the power is on, be very careful when working on the the machine.

Switch off the machine for at least 30 seconds to ensure the motor controller has been completely reset. Then try to start the machine again. If the error returns, troubleshoot as follows:

Fig. 35 1. Measure the interlock signal on the motor controller U1:X302.

No signal

Signal OK

Troubleshoot the motor controller.

Fig. 36 2. Measure the signal on the I/O card 1 interlock bus A11:X10.

No signal

Signal OK

Troubleshoot the cabling between the motor controller and programme unit. Inspect the cabling and replace if necessary.

Troubleshoot the interlock circuits.

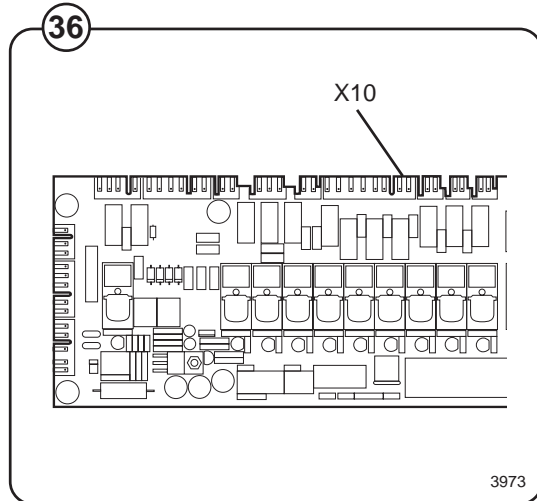
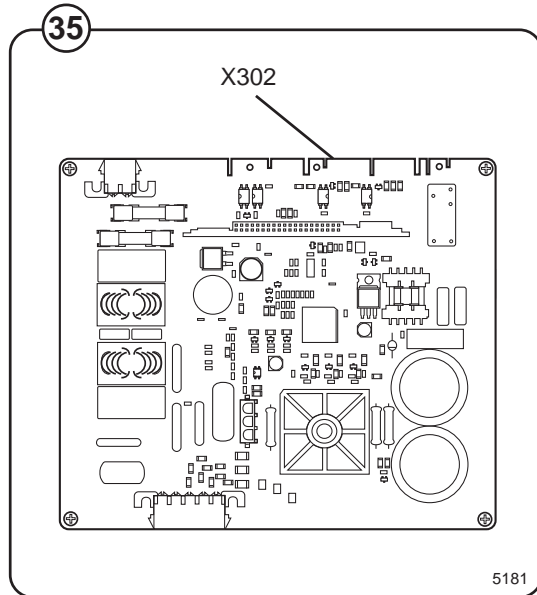

MOTOR SHORTNING

The motor controller indicates a short-circuit in the motor windings, cabling or internally in the motor controller.

If the power is on, be very careful when working on the the machine.

Switch off the machine for at least 30 seconds to ensure the motor controller has been completely reset. Then try to start the machine again. If the error returns, troubleshoot as follows:

Fig. 37 1. Switch off the machine. Undo the contactor at X3 on the motor. Use an ohmmeter to measure the resistance towards the motor. Measure between 1-2, 1-3, and 2-3.

Resistance

W365H	4 ohm
W375H	4 ohm
W3105H	4 ohm
W3130H	2 ohm
W3180H	1,2 ohm
W3240H	0,8 ohm
W3300H	0,8 ohm

Correct resistance



One of the resistance values is incorrect



The motor is probably defective.

Fig. 38 2. Inspect the cabling from X312 on the motor controller to X3 on the motor. Use an ohmmeter and measure the five leads as follows:

X312:	1	2	3	4	5
X3:	1	2	3	7	9 (X3:4 - 6, 8 not used)

Also measure the five leads to be sure there is no short-circuit between any two leads.

Cabling OK



Incorrect cabling



Inspect the cabling and replace if necessary.

The motor controller output is defective.

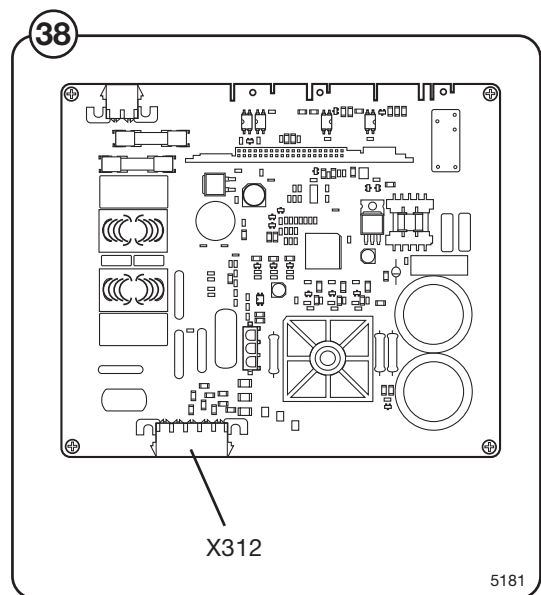
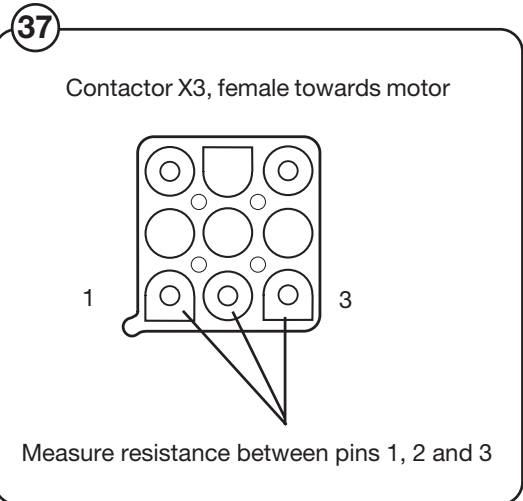

INTERLOCK HARDWARE

The motor controller indicates an error in the interlock receiving circuit.



If the power is on, be very careful when working on the the machine.





Switch off the machine for at least 30 seconds to ensure the motor controller has been completely reset. Then try to start the machine again.

If the error returns, the motor controller is probably defective.

LOW DC VOLTAGE

The motor controller indicates the DC level is too low.

If the power is on, be very careful when working on the the machine.

Switch off the machine for at least 30 seconds to ensure the motor controller has been completely reset. Then try to start the machine again. If the error returns, troubleshoot as follows:

Fig. 39 1. Verify the voltage supply (230 V) to the motor controller at the contactor X311.

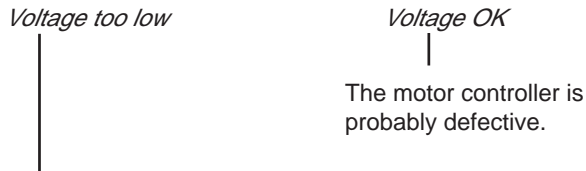
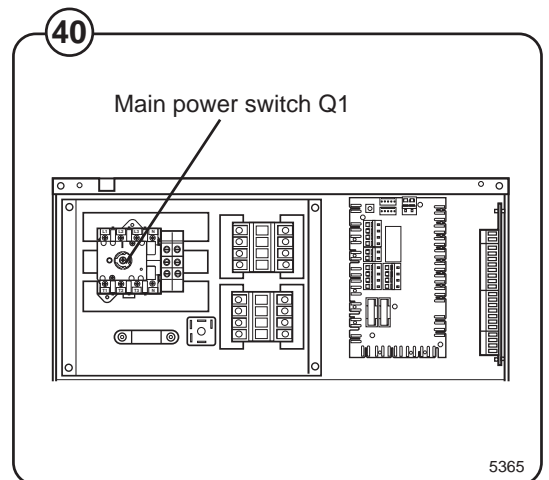
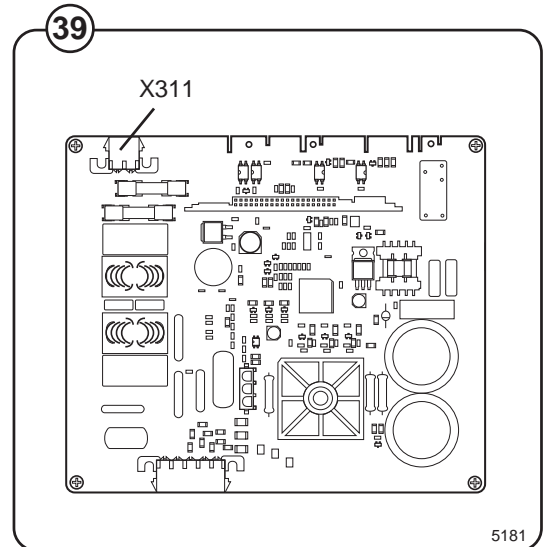
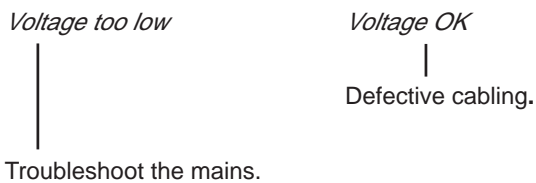



Fig. 40 2. Inspect the power supply (230 V) at the main power switch Q1 on the machine.



HIGH DC VOLTAGE

The motor controller indicates the DC level is too high.

If the power is on, be very careful when working on the the machine.

Switch off the machine for at least 30 seconds to ensure the motor controller has been completely reset. Then try to start the machine again. If the error returns, troubleshoot as follows:

Fig. 41 1. Verify the voltage supply (230 V) to the motor controller at the contactor X311.

Voltage too high

Voltage OK

The motor controller is probably defective.

Fig. 42 2. Inspect the power supply (230 V) at the main power switch Q1 on the machine.

Voltage too high

Voltage OK

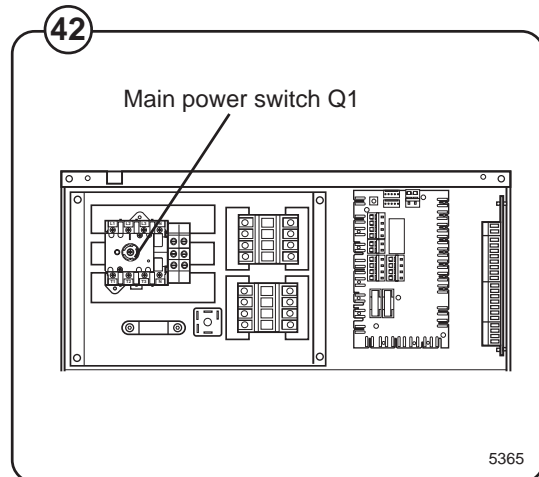
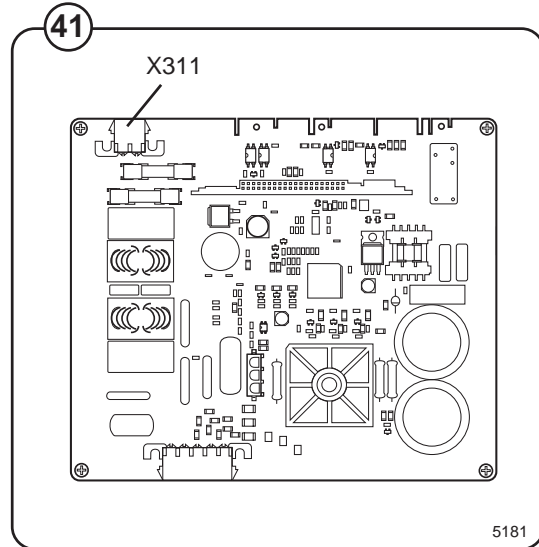

Defective cabling.

Troubleshoot the mains.



RIPPEL ON DC BUS

The DC voltage level fluctuates too much.

If the power is on, be very careful when working on the the machine.

Switch off the machine for at least 30 seconds to ensure the motor controller has been completely reset. Then try to start the machine again. If the error returns, troubleshoot as follows:

Fig. 43 1. Verify the voltage supply (230 V) to the motor controller at the contactor X311.

<p><i>Large voltage fluctuations</i></p> <p>↓</p>	<p><i>Voltage OK</i></p> <p>↓</p> <p>The motor controller is probably defective.</p>
---	--

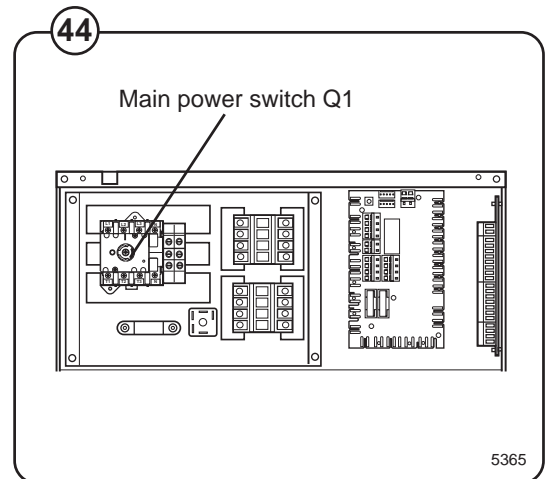
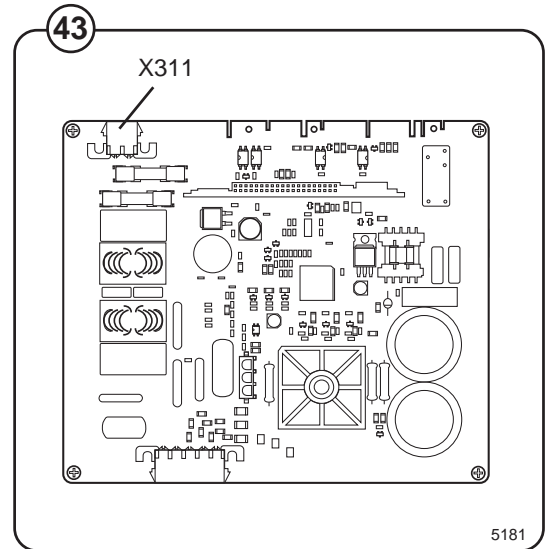

Fig. 44 2. Inspect the power supply (230 V) at the main power switch Q1 on the machine.

<p><i>Large voltage fluctuations</i></p> <p>↓</p> <p>Troubleshoot the mains.</p>	<p><i>Voltage OK</i></p> <p>↓</p> <p>Defective cabling.</p>
--	---



LINE INTERRUPT

The motor controller is missing a phase.

If the power is on, be very careful when working on the the machine.

Switch off the machine for at least 30 seconds to ensure the motor controller has been completely reset. Then try to start the machine again. If the error returns, troubleshoot as follows:

Fig. 45 1. Verify the voltage supply (230 V) to the motor controller at the contactor X311.

<p><i>No voltage</i></p> <p>↓</p>	<p><i>Voltage OK</i></p> <p>↓</p> <p>The motor controller is probably defective.</p>
-----------------------------------	--

Fig. 46 2. Inspect the voltage supply (230 V) at the main power switch Q1 of the machine. For machine with neutral leads, measure between L1 and N; for machines without neutral leads, measure between L1 and L2.

<p><i>No voltage</i></p> <p>↓</p>	<p><i>Voltage OK</i></p> <p>↓</p> <p>Defective cabling.</p>
-----------------------------------	---

Troubleshoot the mains.

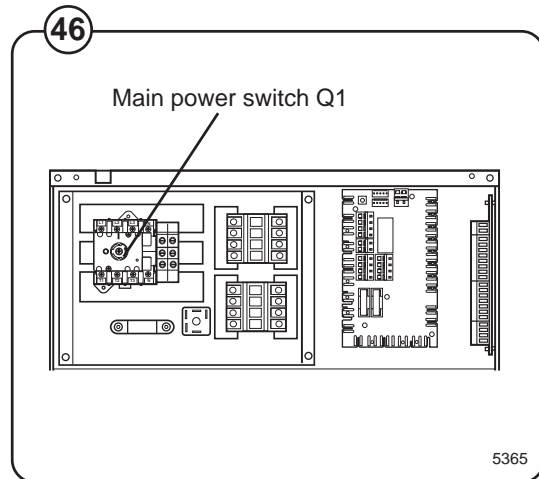
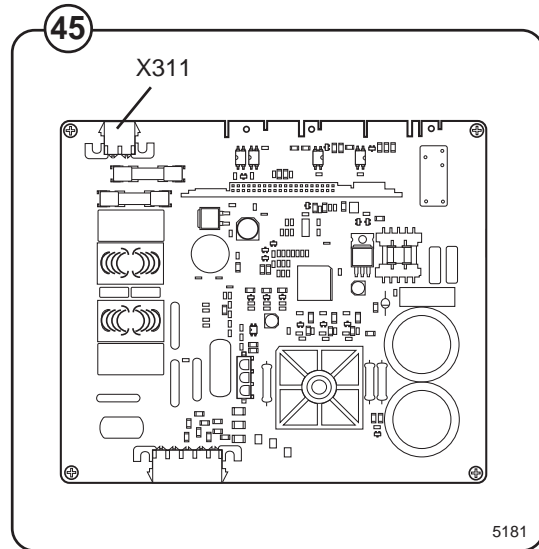

KLIXON CIRCUIT

The motor controller indicates an error in the thermal protection circuits of the motor.



If the power is on, be very careful when working on the machine.

Switch off the machine and for about 30 seconds. Then switch on the machine again and start a programme.

If the error returns, the motor controller is probably defective.

Troubleshooting the keypad in the display unit

When a key is pressed on the keypad of the programme unit, two of the outputs on the keypad close. By disconnecting the flat cable from the display card, pressing a key and measuring the resistance between the outputs that should close, it is possible to determine correct operation of any one key.

Fig. The table below shows the outputs that need to be closed for each key:

48

Key	Outputs that should close
1	2 + 7
2	2 + 6
3	2 + 5
4	3 + 7
5	3 + 6
6	3 + 5
7	4 + 7
8	4 + 6
9	4 + 5
0	5 + 8
A	6 + 8
B	1 + 2
C	1 + 3
D	7 + 8

48

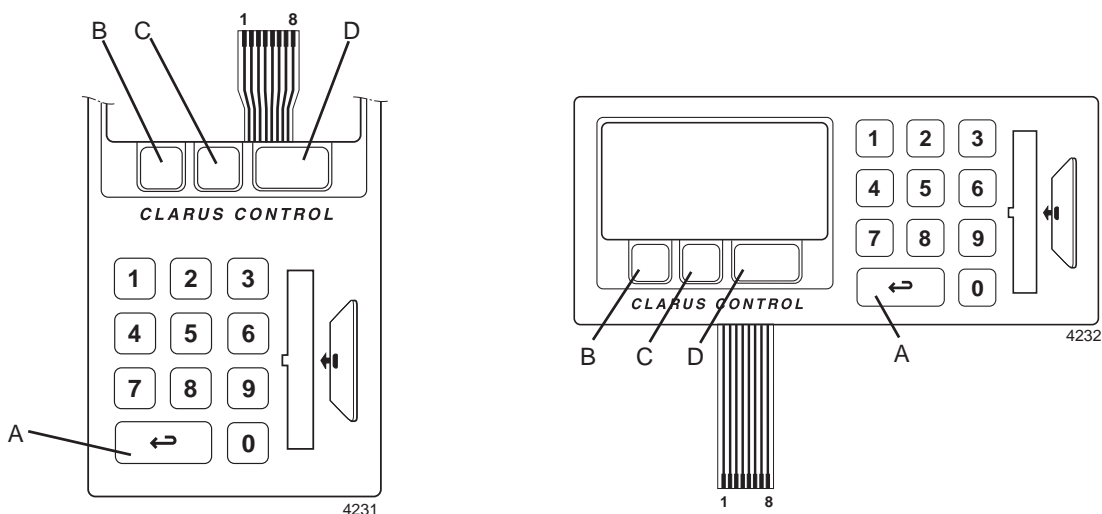

Contents

Description	3
Function	4
Front control unit	4
Rear control unit	7

Description

Fig. 1 The control unit of the machine consists of the following parts:

1

- **Front control unit**

This unit contains two microcomputer controlled electronic programme units consisting of a CPU card A1, display card A2, card reader A3 and one or two I/O cards A11 and A12. The front control unit also holds a door lock control A31 (double check of door lock), a level guard B2 and a lower-voltage transformer T10 that supplies power to the programme unit.

- **Rear control unit**

This unit contains the main power switch Q1 or a connection block with connectors for voltage supply, one or two heating contactors K21 and K22 and one or two communication cards A21 and A22 with outputs for, among others, detergent supply.

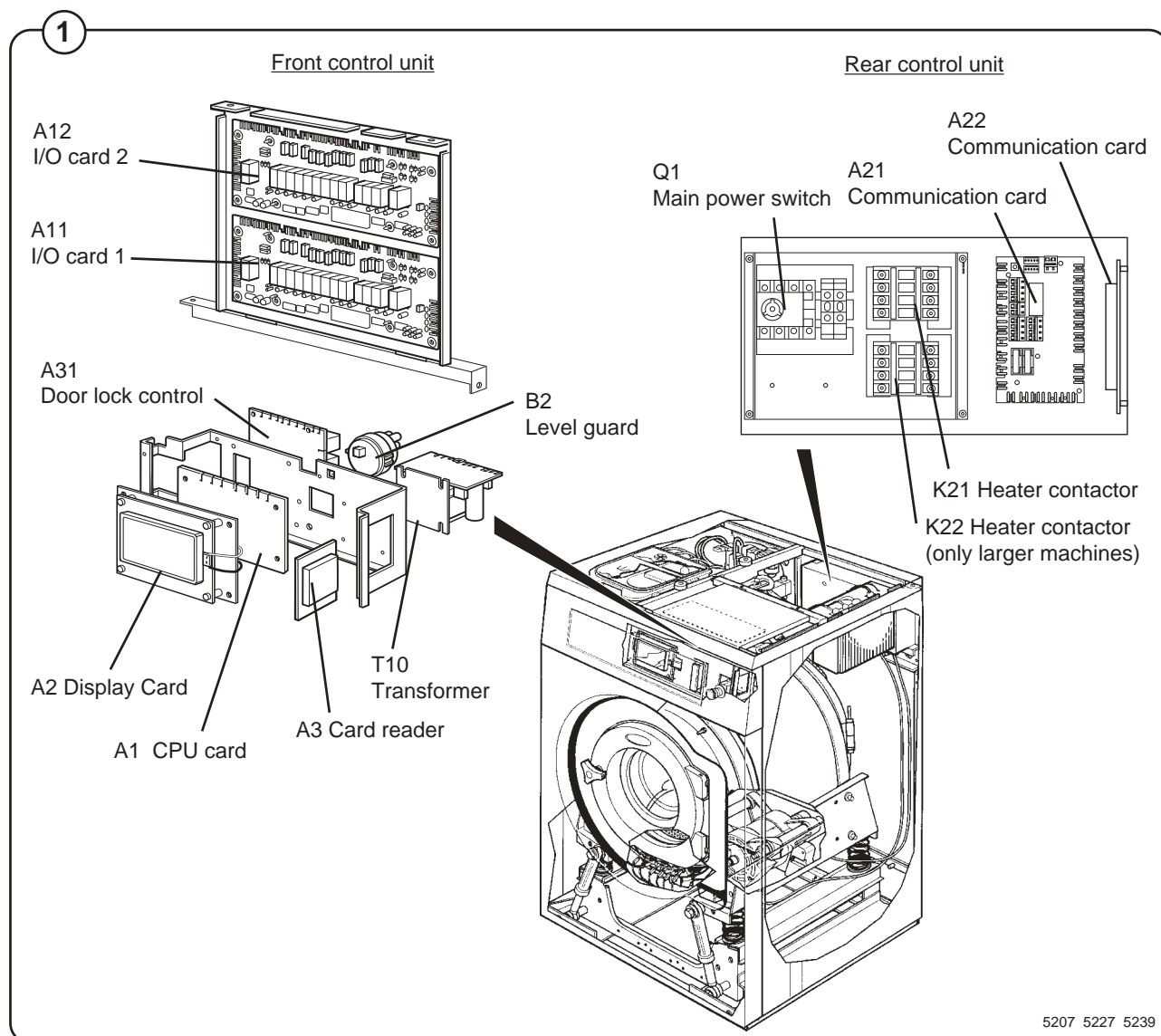

Function

Front control unit

Programme unit

Fig. 2 The programme unit consists of the following parts:

- Fig. 3
- **CPU card A1**
The CPU card uses the various control programmes in the card programme memory to check the various functions of the washing machine. The standard programmes are also stored in the programme memory (programme numbers 991 - 999) together with any user-specified programmes.
 - **Display card A2**
The display card communicates with the CPU card A1 through a serial interface. It converts data from the CPU card for display in the character display.
The display card also detects which buttons are pressed on the control panel.
 - **Card reader A3**
Using the card reader and a memory card, wash programmes can be copied from one washing machine to another or between washing machines and a computer. The card reader is connected to the display card A2.

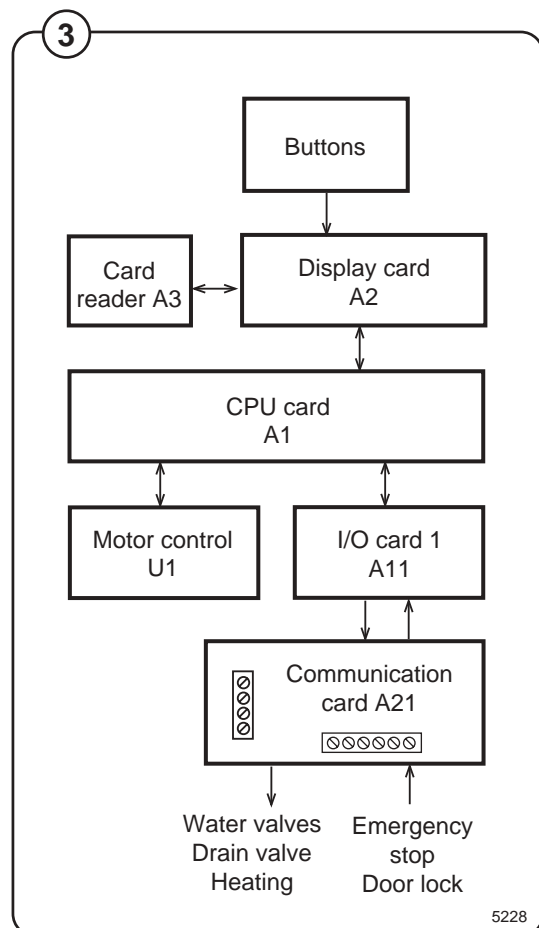
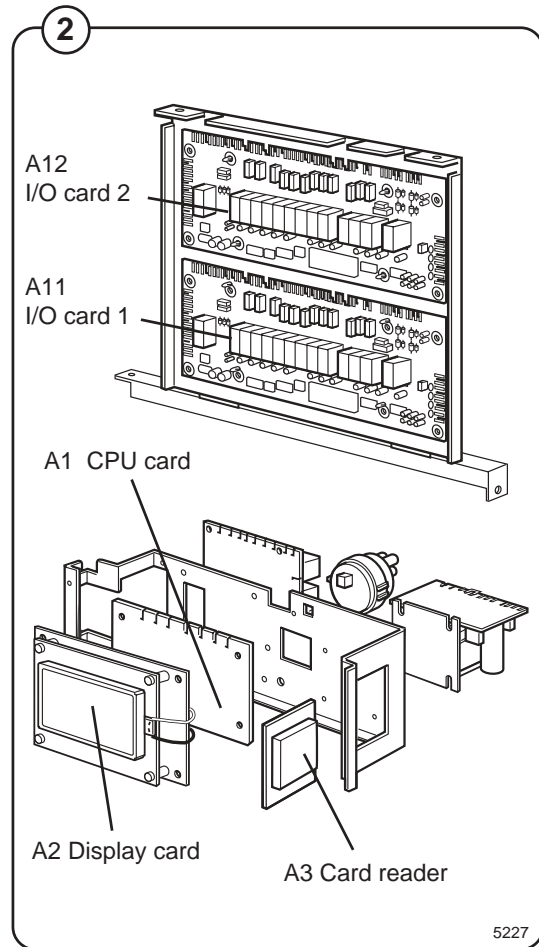

- I/O cards A11 and A12**
 Most smaller machines have only one card: A11. The I/O cards are controlled by the CPU card via a serial interface. The I/O cards feature outputs, which, via the communication card in the rear control unit, control various machine functions, such as the water valves, heating connection and drain valve. The cards also have inputs for emergency stop and door lock.

The programme unit is described in detail in section 23. **Programme unit.**

Level guard B2

Fig. 4 Control of the water level and turning of the drum are controlled with a backup guard, to ensure that the door will not open with water in the drum or when the drum rotates.

Apart from the level guard on the CPU card, there is a level guard B2, connected to the door lock control A31. This card controls door locking action as well as the level and drum rpm speed.

Transformer T10

Fig. 5 The low voltage transformer supplying power to the various cards operates on DC power.

Using the short-circuit connectors on the PCB, the transformer can be switched to one of four different voltage supplies.

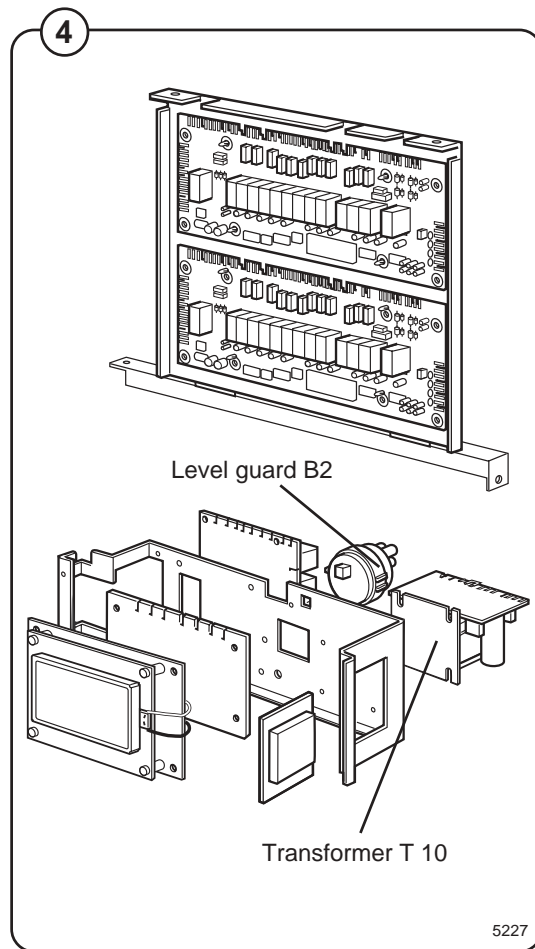

5227

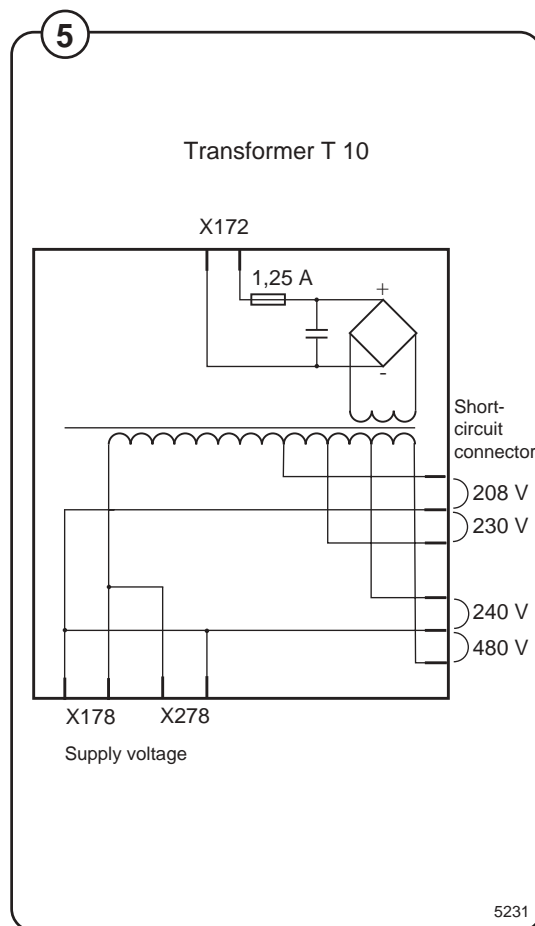

5231

Door lock control A31

Fig. 6 This card serves to perform a safety check of the door lock function.

The card checks the water level using level guard B2 and the drum speed by way of a rotation sensor B3. The card receives a signal from the CPU card when the door should be locked or opened.

The door lock control controls the door lock coil and the door lock does not open or close until the card itself and the programme unit have verified that the drum is not turning and that there is no water remaining in the drum.

The door lock control is described in detail in section 29. **Door and door lock.**

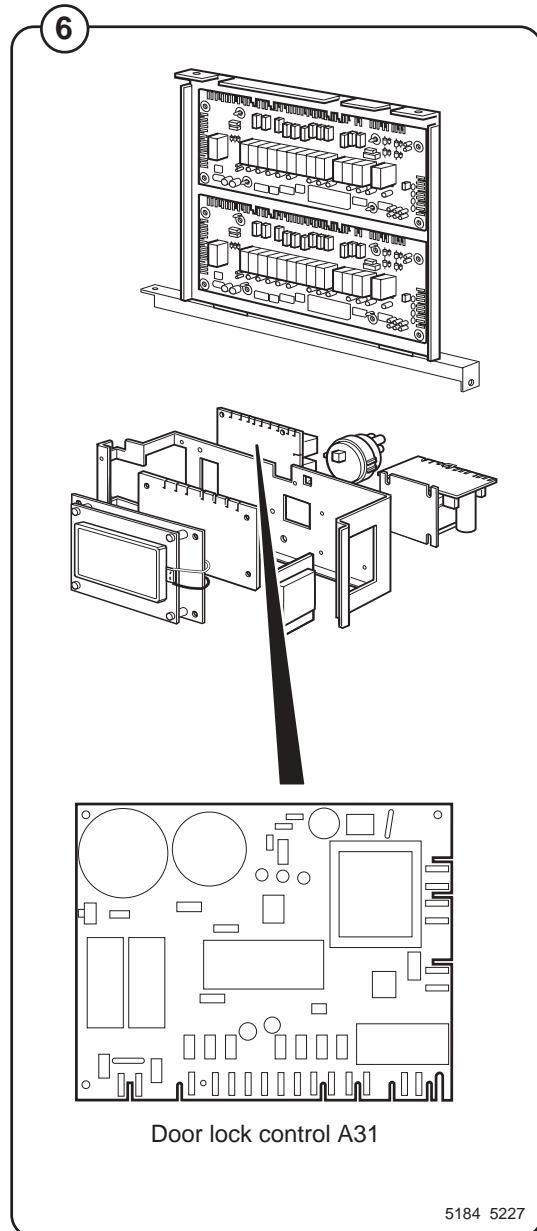

Rear control unit

Main power switch Q1

Fig. 7 The main power switch interrupts all received power phases and is situated on the outside of the connection box cover.

The cover cannot be removed unless the main power switch is turned to the 0 position.

The received voltage supply is connected to the lower connection block row of the main power switch or, alternatively, to the input connection block.

Heating contactor K21

This contactor is only featured on machines with electric heating.

It activates the three heating elements at the front, lower part of the outer drum. It is controlled by I/O card 1 output X8.

Heating contactor K22

This contactor is only featured on larger machines with three heating elements, with each element having two cores.

It activates the three heating elements at the front, lower part of the outer drum. It is controlled by I/O card 1 output X8.

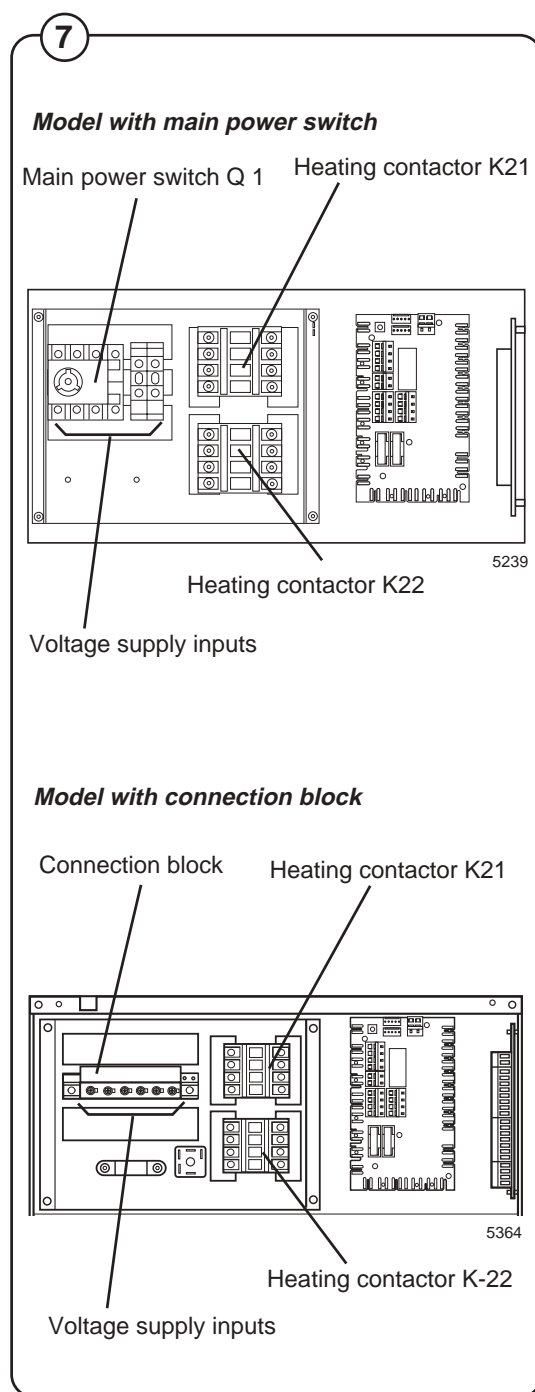

Communication card A21

Fig. 8 This card is used to send and receive signals from I/O card 1. It contains:

- Fig. 9**
 - **Fuses F11 and F12 (T 1.25 A)**
Protects the received voltage supply in the timer and door lock controller.
 - **Service button S40**
Used to engage service mode of the programme unit.
 - **Input/output connection blocks**

Card No.	Function
<u>Outputs (200 - 240 V AC)</u>	
X71	:1,2 Signal "Door locked, program on"
X72	:2 Liquid detergent 1
	:3 Liquid detergent 2
	:4 Liquid detergent 3
	:5 Liquid detergent 4
	:1 0 V
X73	:1 Powder 1 (Y11)
	:2 Powder 2 (Y12)
	:3 Powder 3 (Y13)
	:4 Powder 4 (Y14)
	:5 Powder 2 (Y22)
<u>Input</u>	
X70	:1,2 Start/Stop
	:3,4 Pause/PC5

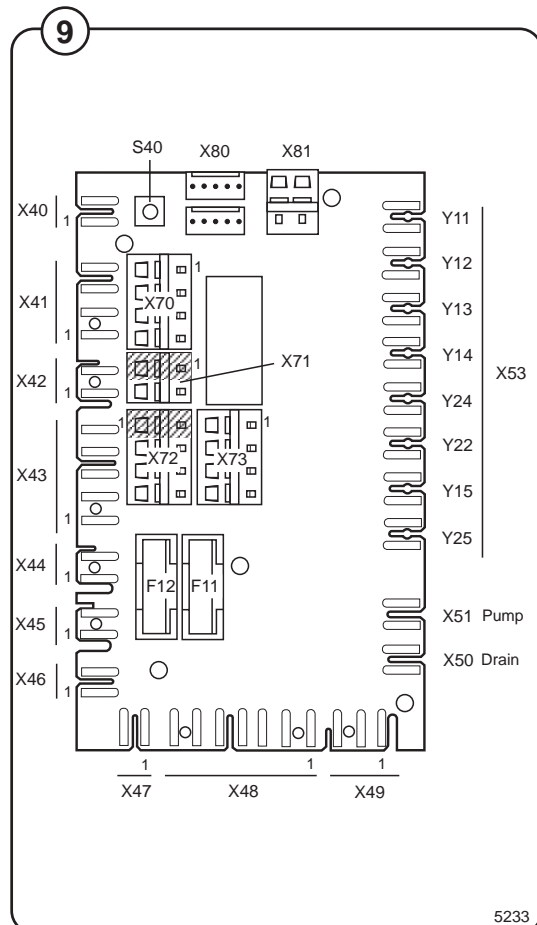
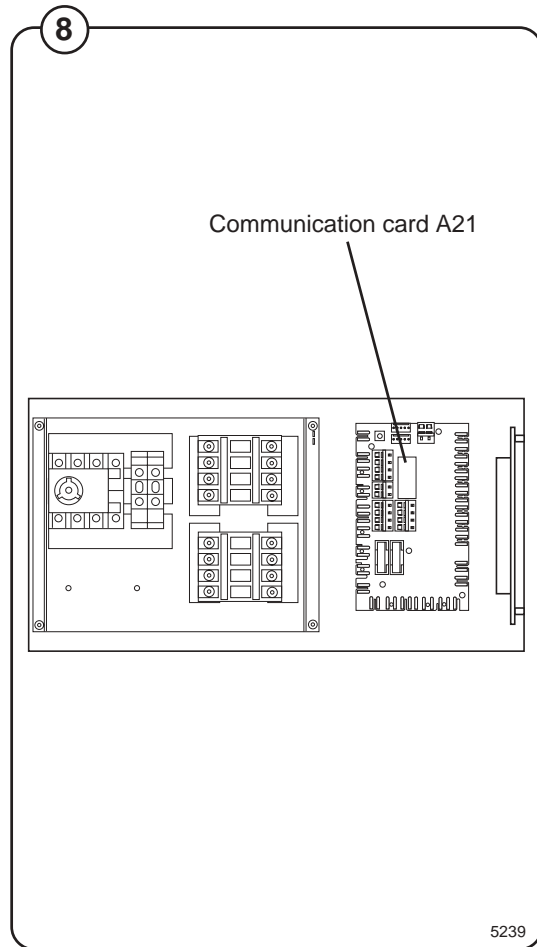

Communication card A22

Fig. 10 This card is used to send and receive signals from I/O card 2. It contains:

Fig. 11 • **Input/output connection blocks**

Card No.	Function
<u>Output (200 - 240 V AC)</u>	
X75 :1	0 V
:2	Liquid detergent 5
:3	Liquid detergent 6
:4	Liquid detergent 7
:5	Liquid detergent 8
X76 :1	0 V
:2	Drain block
:3	Drain A
:4	Drain B
:5	Drain C
:6	Inlet A
:7	Inlet B
:8	Inlet C
X77 :1,2	Buzzer
<u>Input</u>	
X74 :1,2	Switching between heater 1/heater 2
:3,4	No function

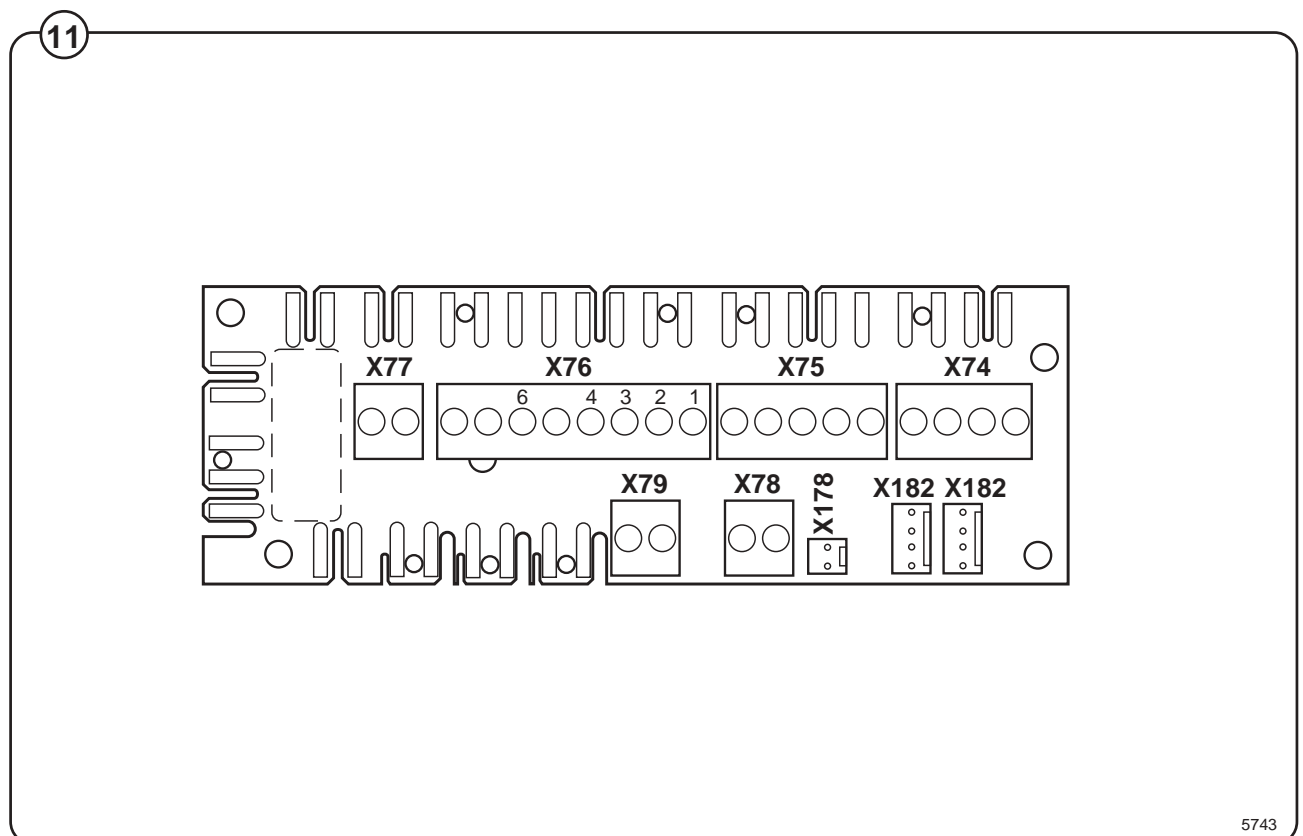
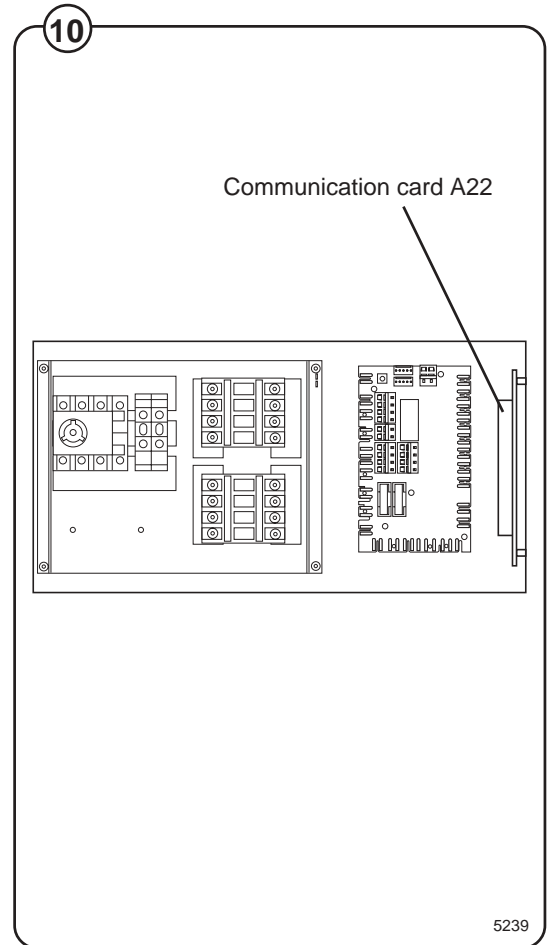

Contents

Description	3
Function	5
CPU card A1	5
Display card A2	7
I/O-cards	8
Input and outputs on I/O cards 1 and 2	9
The service program	14
To select the "Service program" function	15
To control the machine functions	17
I/O card inputs	18
Settings 1	19
To select the "Settings 1" function	20
Password	21
Variables under "Settings 1"	23
Settings 2	44
To select the "Settings 2" function	45
Variables in Settings 2	46
To replace the CPU board	72
To replace an I/O board	75
Imbalance detection	79

Description

Fig. 1 The programme unit of the machine consists of the following parts:

Fig. 2

- **CPU card A1**
The CPU card uses the various control programmes in the card programme memory to check all the functions of the washing machine. The standard programmes are also stored in the programme memory (programme numbers 991 - 999) together with any user-specified programmes.

The CPU card controls the display card A2 (display window, control panel and the A3 card reader), I/O cards A11 and A12 and the motor controller U1 via the serial data interface.

- **Display card A2**
The display card receives data from CPU card A1 about which text to display in the display window. The display card converts this data and control the display window in order that the correct data is shown.

The display card also senses which keys are pressed on the keyboard and sends the received information to the CPU card.

- **Card reader A3**
Using the card reader, it is possible to copy washing programmes from the CPU card memory to a memory card or from memory cards to the CPU memory.

The memory cards can then be inserted in a card reader of another washing machine or in a reader connected to a PC. This allows copying of washing programmes from one machine to another or between a PC and washing machines. The card reader is connected to the display card A2.

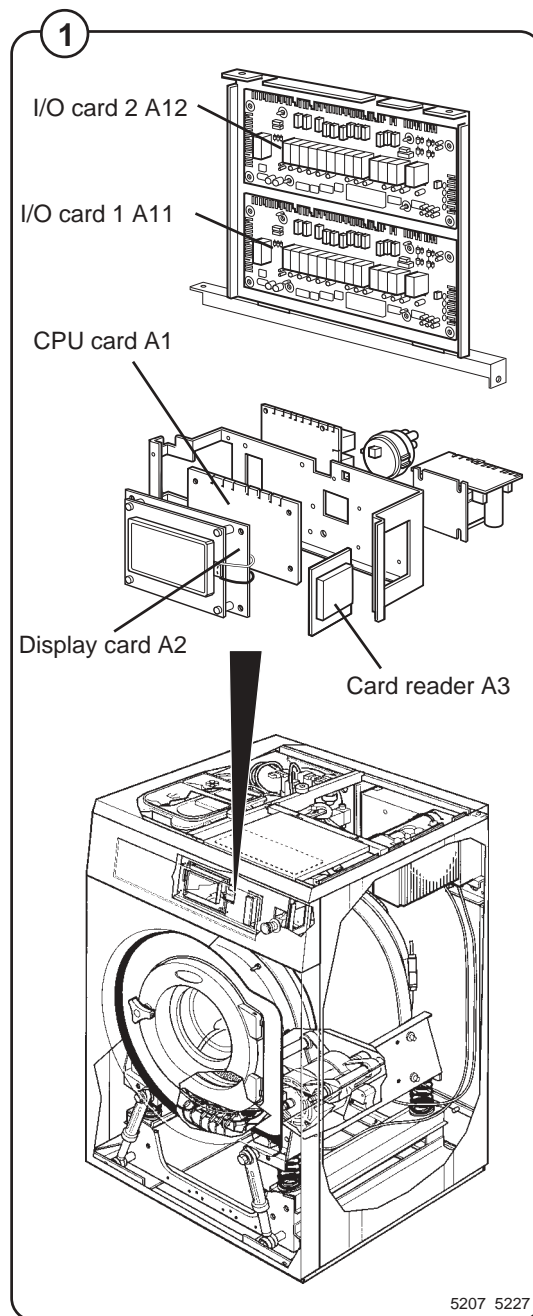

5207 5227

- I/O cards A11 and A12**

Most smaller machines have only one card: A11. On some machines, there is a greater need for outputs, in which case two I/O cards are used.

The I/O cards are controlled by the CPU card via a serial interface. The I/O cards feature outputs, which, via the communication cards in the rear electric box, control various machine functions, such as the water valves, heater connection and drain valve. On the input connection blocks of the communication cards, it is possible to connect signals for control of e.g. the detergent supply.

The cards also have inputs for emergency stop and door lock ACK.

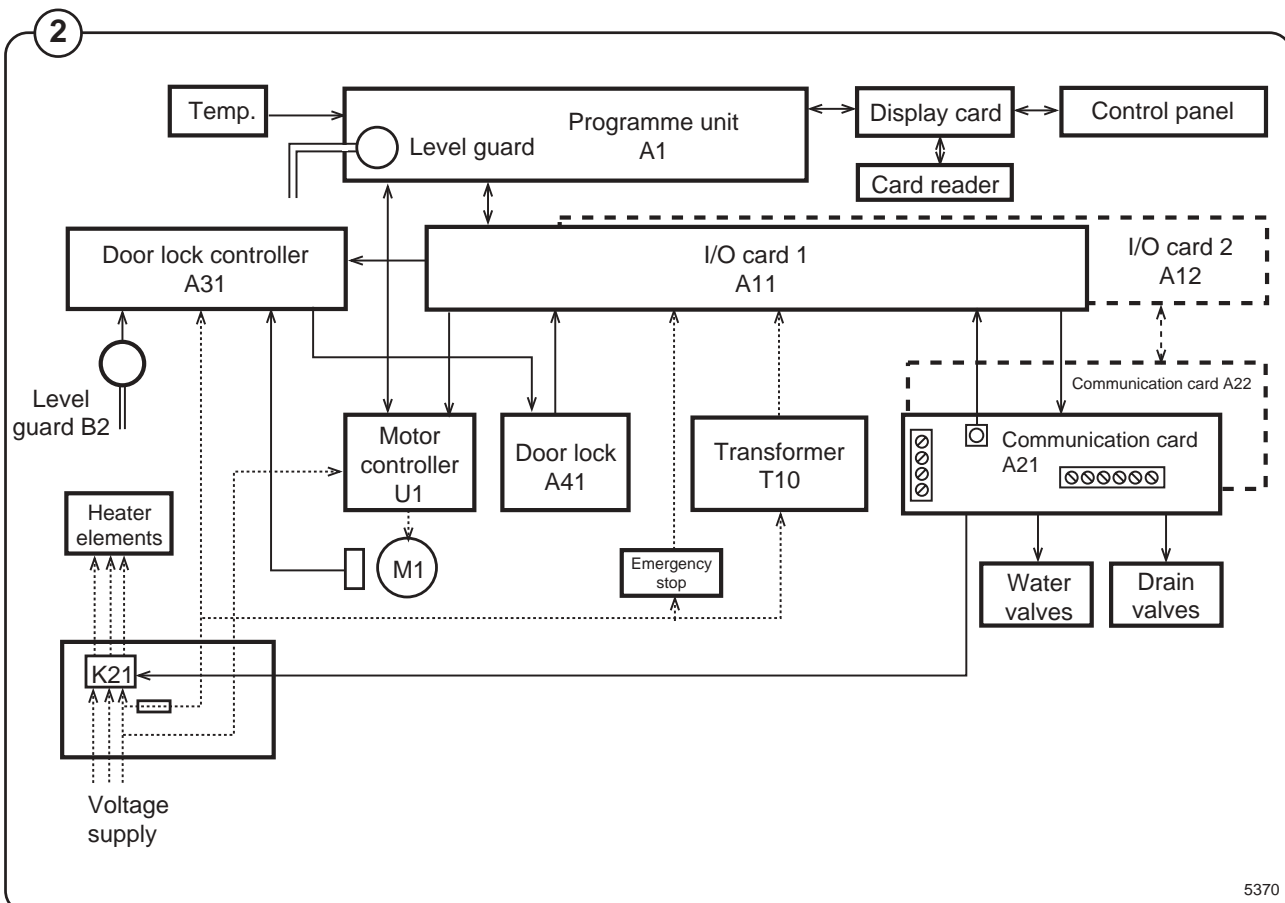

Function

CPU card A1

Fig. 3 The CPU card controls all functions of the washing machine using various control programmes in the CPU card memory. The CPU card communicates with the I/O card, display card and motor controller using a serial interface.

The following functions are controlled:

- The CPU card controls the water valves, detergent supply, drain and heating using one or two I/O cards. Depending on the number of functions to be controlled, the number of I/O cards varies between different machines.
- The CPU card controls the alphanumeric display window on the display card.
- The CPU card controls the motor via a motor controller.

To obtain information about the various operations of the washing machine, the following inputs are used:

- The CPU card has inputs for e.g., temperature sensors.
- The CPU card receives information from the I/O card inputs about door locking state and any external switches (e.g., Start/Stop and Pause).
- The CPU card has a pressure sensor to which a hose for measuring the water level in the drum can be connected.
- The CPU card receives information from the display card about which buttons were pressed.

Note that the CPU card does not contain any removable memory chips. If the CPU card needs replacement, the correct software for the machine needs to be programmed in the new card using a laptop with special software. See the section "Replacing the CPU card". Personalised washing programmes can be transferred using a Smart card.

3

The two pins in switch X7 are shorted to confirm changes made in Configuration 1 and 2.

(Not for FOM71 CLS).
Pushbutton SW1: used as an acknowledgement button when in the Service programme mode (the same function is also available on the communication card).

P1, P2 Used for factory calibration of the pressure sensor.

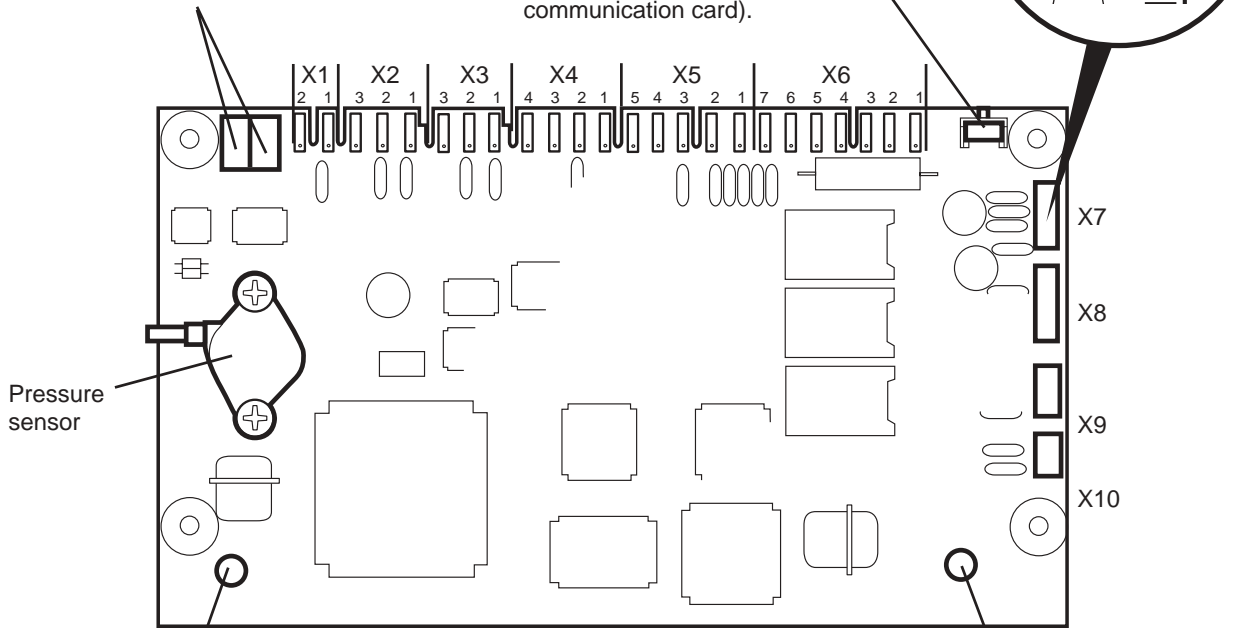
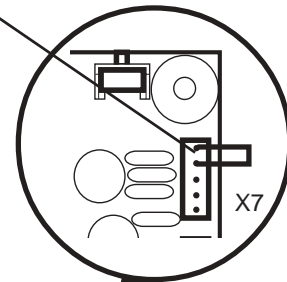

Green LED:
Quick blinks = communication between CPU card and I/O card.

Red LED:
Continuous red light = voltage supply OK

Card Switch Function	
X1	Input from water temperature sensor
X2	not used
X3	not used
X4	Output to motor controller
X5: 1-3	Serial communication with I/O card 1
X5: 4-5	Voltage supply from I/O card 1
X6: 1-5	Serial communication with display card
X6: 6-7	Voltage supply to display card
X7	PC communication
X8	Motor communication (reserved)
X9	Scale communication
X10	Internal communication (not used)

Display card A2

Fig. 4 The display card communicates with the CPU card through a serial interface. The CPU card informs what should be displayed in the display window and the display card converts these messages to information that controls the alphanumeric display window.

The display card also detects which buttons are pressed on the control panel and sends these signals to the CPU card.

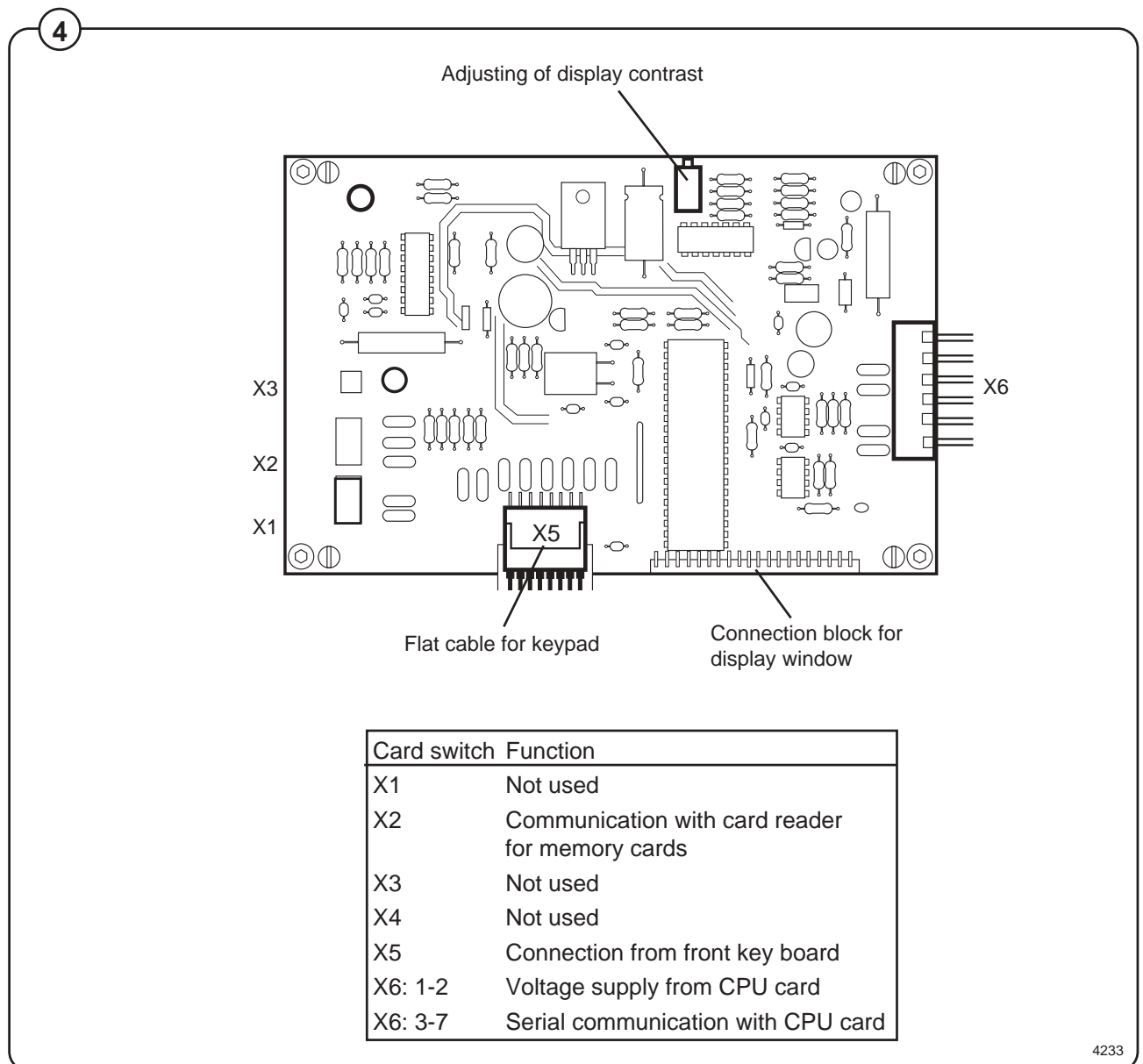

I/O cards

Fig. 5 The I/O cards are controlled by the CPU card and communicate via a serial interface. Depending on the need for inputs and outputs, one programme unit may have one or two I/O cards.

All inputs and outputs are switched from the I/O card to the various functions via the communication cards in the rear electric module. Each I/O card is connected to a separate communication card: I/O card A11 uses communication card A21 and I/O card A12 uses communication card A22.

There are inputs for door lock and external switches (e.g. Start/Stop and Pause). Signals on these inputs are passed on to the CPU card.

The outputs control water valves, detergent supply, drain and heating.

The voltage supply to the CPU and I/O cards takes place via I/O card 1 A11, which feeds voltage to both the CPU card A1 and a possible I/O card 2 A12.

Note that if the programme unit uses two cards and one needs to be replaced, special programming is required. It is necessary to programme the new card with the correct I/O card number (1 or 2) using a laptop and special software. See the section "Replacing the I/O card".

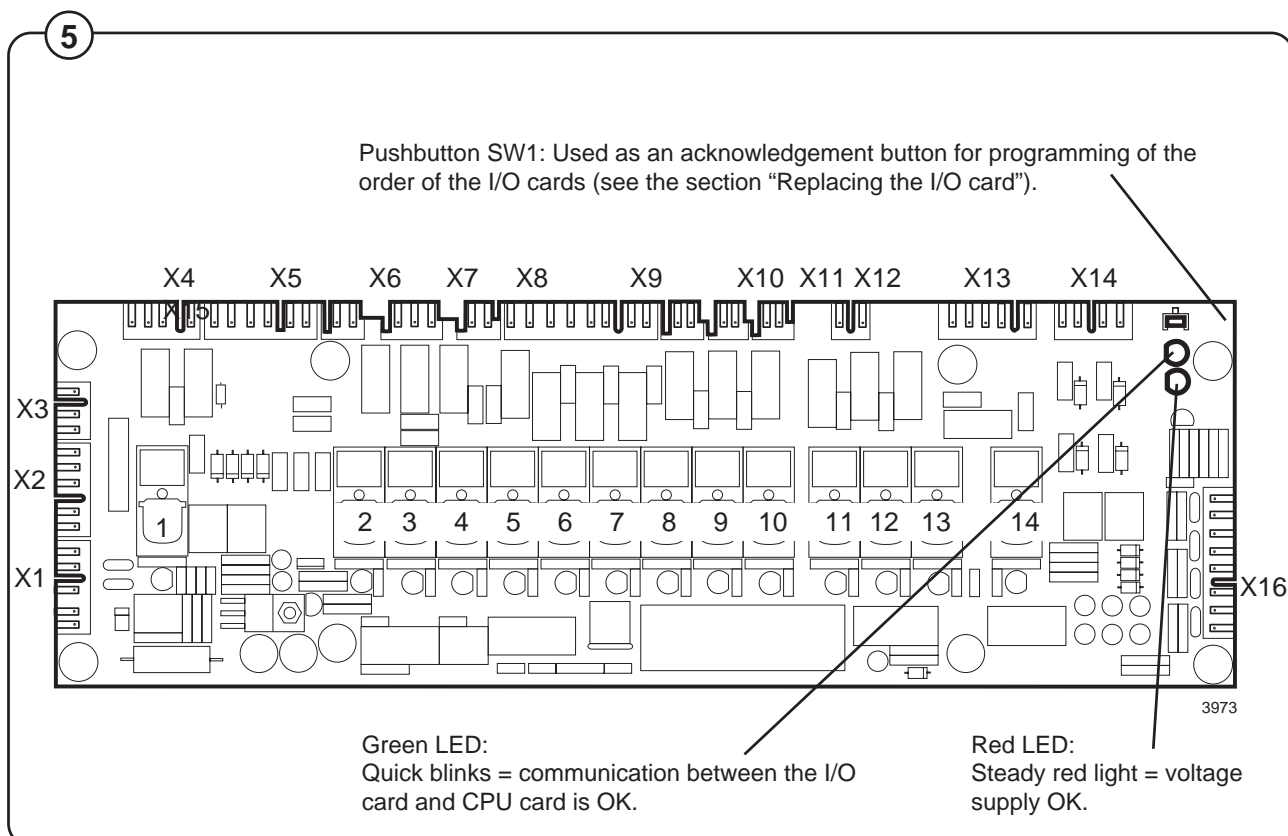

Input and outputs on I/O cards 1 and 2

Card switch	I/O-card 1 A11	I/O-card 2 A12
Serial interface and voltage supply		
X1: 1-3	Serial interface to card 2	-
4	16 V+ supply to card 2	-
5	0 V– supply to card 2	-
X2: 1	0 V– supply to CPU	12 V- from card 1
2	16 V+ supply to CPU	12 V+ supply from card 1
3-5	Serial interface to CPU	Serial interface to card 1
X3: 1	16 V+ supply from T10	-
2	0V- supply from T10	-
X6: 1	230 V supply from emergency stop, phase	230 V direct supply, phase
2	230 V supply from emergency stop, neutral	230 V direct supply, neutral
X10:1	Interlock signal to motor controller, phase	Supply to relays from I/O 1, phase
2	Interlock signal to motor controller, neutral	Supply to relays from I/O 1, neutral
X11:1	Supply to relays from I/O 2, phase	-
2	Supply to relays from I/O 2, neutral	-
X12:1	To X13: supply to relays 11-14, phase	To X13: supply to relays 11-14, phase
2	To X13: supply to relays 11-14, neutral	To X13: supply to relays 11-14, neutral
X13:1	Supply to relays 11-14, neutral	Supply to relays 11-14, neutral
2	Supply to relays 11-14, phase	Supply to relays 11-14, phase

Inputs and outputs on I/O cards 1 and 2

I/O-card	D.card A21	I/O-card 1 A11
Connection block No.	Switch No.	Relay No. Function
Outputs		
X4: 1		Neutral
2	1	Door lock relay, phase (normally open)
3		Neutral
4	1	Door lock relay, phase (normally open)
X7: 1	2	Drain 1 (Y1), phase (normally open)
2		Common neutral
3	2	Drain 1 (D1), phase (normally closed)
X8: 1	3	Heater relay (K21)
2		Neutral
X9: 1	9	Hot water inlet (Y25)
2	8	X73: 5 Powder 5 (Y22)
3	10	X73: 4 Powder 4 (Y14/24)
4	7	Cold water inlet (Y15)
5	6	X73:3 Powder 3 (Y13/Y23)
6	5	X73:2 Powder 2 (Y12/Y22)
7	4	X73:1 Powder 1 (Y11/Y21)
8		N (common neutral)
X14:1	14	X72:5 Signal 4, external detergent pump
2	12	4 Signal 3, external detergent pump
3	13	3 Signal 2, external detergent pump
4	11	2 Signal 1, external detergent pump
5		1 N (common neutral)

Inputs and Outputs on I/O card 1 and 2

I/O-card	D.card A22	I/O-card 2 A12
Connection block No.	Switch No.	Relay No. Function
Outputs		
X4: 1		-
2	1	X77:1 Flashlight, phase
3		-
4	1	
X7: 1	2	Cold, hard water (Y35)
2		N (neutral)
3	2	-
X8: 1	3	Heater relay (K22)
2		Neutral
X9: 1	9	X76:8 Inlet C (Y65)
2	8	7 Inlet B (Y55)
3	10	6 Inlet A (Y45)
4	7	5 Drain C (Y4)
5	6	4 Drain B (Y3)
6	5	3 Drain A (Y2)
7	4	2 Drain stop (Y1b)
8		1 N (common neutral)
X14:1	14	X75:5 Signal 8, external detergent pump
2	12	4 Signal 7, external detergent pump
3	13	3 Signal 6, external detergent pump
4	11	2 Signal 5, external detergent pump
5		1 N (common neutral)

I/O-card	D.card A21	I/O-card 1 A11
Connection block No.	Opto-coupler	Relay No.
		Function

Inputs

X5: 1			Door lock micro-switch S4/N, Com
2			Door lock micro-switch S4/N, No
3-4	1		Door lock position micro-switch S3/N
5-6	2		Door lock micro-switch S4/Phase
X15:1	4	X70:4	External start/stop signal, phase
2	4	3	External start/stop signal, neutral
3	3	2	External pause signal, phase
4	3	1	External pause signal, neutral
X16:1-2			ACK, emergency stop (S2)
3-4			External service switch
5-6			-
7-8			-

I/O-card	D.card A22	I/O-card 2 A12	
Connection block No.	Opto-coupler	Relay No.	Function

Inputs

X5: 1			-
2			-
3-4	1		-
5-6	2		-
X15:1	4		-
2	4		-
3	3	X74:2	Switch heat 1/heat 2, phase
4	3	1	Switch heat 1/heat 2, neutral
X16:1-2			-
3-4			-
5-6			-
7-8			-

The service program

The service programme facilitates troubleshooting on the machine by enabling control of **all machine functions**. **Input signals to the various I/O cards** that are active are also indicated.

The following functions can be controlled:

01	COLD WATER	36	LOW EXTRACT
02	HOT WATER	37	MEDIUM EXTRACT
03	COLD HARD WATER	38	HIGH EXTRACT
04	TANK 1 WATER	39	TURBO EXTRACT
05	TANK 2 WATER	40	NORMAL DRAIN
06	TANK 3 WATER	41	DRAIN BLOCKING
07	FLUSH	42	RECYCLE DRAIN A
10	DETERGENT POWDER 1	43	RECYCLE DRAIN B
11	DETERGENT POWDER 2	44	RECYCLE DRAIN C
12	DETERGENT POWDER 3	45	RECYCLE DRAIN D
13	DETERGENT POWDER 4	46	FLASHING LIGHT
14	DETERGENT POWDER 5	51	DOOR LOCK
17	LIQUID DETERGENT 1	55	HEAT 1
18	LIQUID DETERGENT 2	56	HEAT 2
19	LIQUID DETERGENT 3	64	BUZZER
20	LIQUID DETERGENT 4		
21	LIQUID DETERGENT 5		
22	LIQUID DETERGENT 6		
23	LIQUID DETERGENT 7		
24	LIQUID DETERGENT 8		
33	MOTOR CLOCKWISE		
34	MOTOR COUNTERCLOCKWISE		
35	DISTRIBUTION		

These signals can be read:

I/O-BOARD 1:

EMERGENCY STOP
TEMPORARY PAUSE
OIL
REMOTE START
SERVICE
PHASE CHECK
DOOR LOCKED
DOOR CLOSED
UNBALANCE

I/O-BOARD 2:

CHANGE HEATING SYSTEM
REPEAT RINSE

To select the "Service Program" function

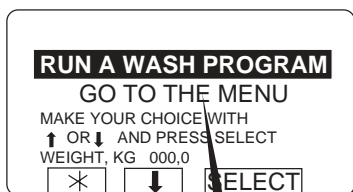

If this menu is not currently displayed:
 Press repeatedly.



Press to highlight "GO TO THE MENU".



Press SELECT.

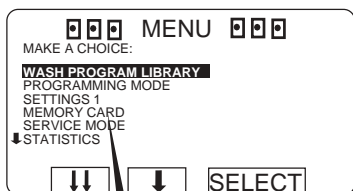

Press four times.

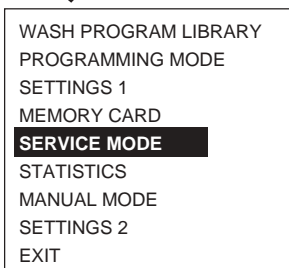

... to highlight "SERVICE MODE".



Press SELECT.

The service program

The service program makes fault-finding on the machine easier, as it allows you to control the various machine functions individually:

- water filling
- detergent flushing
- motor rotation, clockwise and counterclockwise
- motor action, distribution and extraction
- drain
- door lock
- heating
- buzzer

You can also check which input signals to the PCU are activated:

- emergency stop
- remote start
- oil lubrication
- service
- repeat rinse
- phase check
- door locked
- door closed
- unbalance

The following values will also be displayed at all times:

- water level in machine
- water temperature
- motor speed
- whether drain is open or closed

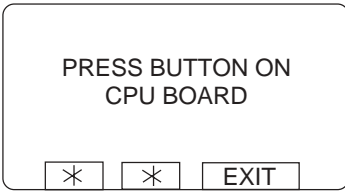

Not for FOM71 CLS.

Press the **button** on the CPU circuit board.



To access the service program:



Press **Select**.

To prevent unauthorised or accidental use

Unauthorised or accidental use of the service program is prevented by requiring the user to locate and press the button on CPU board.

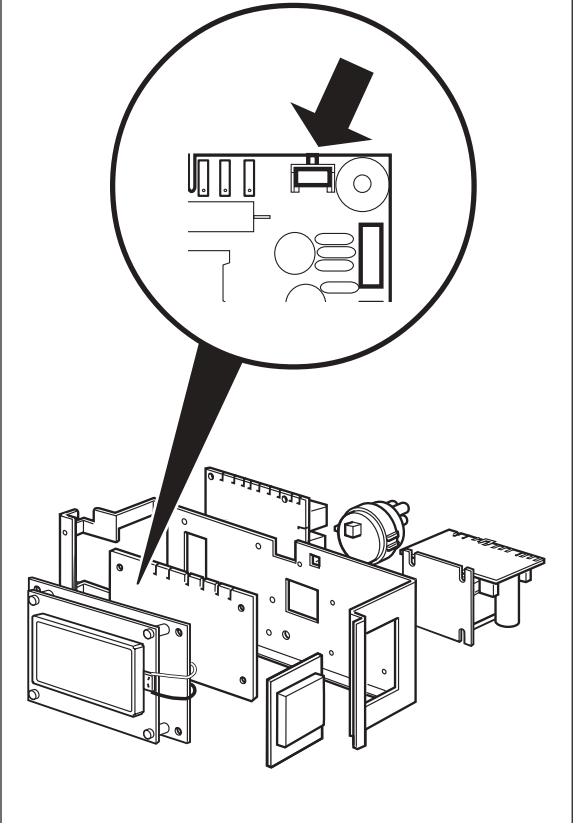

To control the machine functions

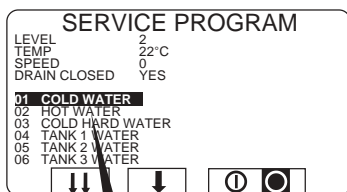

- 01 COLD WATER
- 02 HOT WATER
- 03 COLD HARD WATER
- 04 TANK 1 WATER
- 05 TANK 2 WATER
- 06 TANK 3 WATER
- 07 FLUSH
- 10 DETERGENT POWDER 1
- 11 DETERGENT POWDER 2
- 12 DETERGENT POWDER 3
- 13 DETERGENT POWDER 4
- 14 DETERGENT POWDER 5
- 17 LIQUID DETERGENT 1
- 18 LIQUID DETERGENT 2
- 19 LIQUID DETERGENT 3
- 20 LIQUID DETERGENT 4
- 21 LIQUID DETERGENT 5
- 22 LIQUID DETERGENT 6
- 23 LIQUID DETERGENT 7
- 24 LIQUID DETERGENT 8
- 25 LIQUID DETERGENT 9
- 26 LIQUID DETERGENT 10
- 27 LIQUID DETERGENT 11
- 28 LIQUID DETERGENT 12
- 29 LIQUID DETERGENT 13
- 33 MOTOR CLOCKWISE
- 34 MOTOR COUNTERCLOCKWISE
- 35 DISTRIBUTION
- 36 LOW EXTRACT
- 37 MEDIUM EXTRACT
- 38 HIGH EXTRACT
- 39 TURBO EXTRACT
- 40 NORMAL DRAIN
- 41 DRAIN BLOCKING
- 42 RECYCLE DRAIN A
- 43 RECYCLE DRAIN B
- 44 RECYCLE DRAIN C
- 45 RECYCLE DRAIN D
- 46 FLASHING LIGHT
- 51 DOOR LOCK
- 55 HEAT
- 56 HEAT 2 AS STANDARD
- 64 BUZZER
- EXIT

To activate the various machine functions:

Use or to highlight the function. Press to switch the function on and off.

I/O card inputs

1 Press 1.

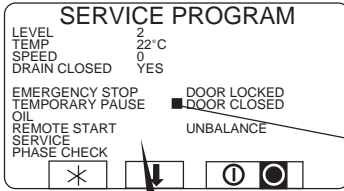

Now you can check the various input signals from I/O board 1.

A black square in front of the name indicates that the input is active.

I/O-BOARD 1

EMERGENCY STOP
TEMPORARY PAUSE
OIL
REMOTE START
SERVICE
PHASE CHECK
DOOR LOCKED
DOOR CLOSED
UNBALANCE

Press any key to go back to the previous display.

When the programme unit has two I/O cards:

2 Press 2.

I/O-BOARD 2

CHANGE HEATING SYSTEM
REPEAT RINSE

It is now possible to verify the various input signals from I/O card 2.



Press any key to go back to the previous display.



Settings 1

In the Configuration 1 mode, the variables can be changed without requesting a special password from the supplier:

ADJUST TIME ALLOWED	LEVEL HIGH
ADJUST TEMPERATURE ALLOWED	MIDDEL TEMPERATURE COOL-DOWN
RAPID ADVANCE ALLOWED	DEFAULT MOTOR ON TIME
SHOW WEIGHT ALLOWED	DEFAULT MOTOR OFF TIME
WATER REDUCTION NOT ALLOWED	FLUSH DELAY TIME
MANUAL FUNCTIONS ALLOWED	FLUSH ON TIME
PAUSE ALLOWED	BUZZER ON BUTTON
FREE TEXT ALLOWED	MAX FILLING TIME
CHANGE WASH PROGRAM ALLOWED	MAX HEATING TIME
AUTO RESTART ALLOWED	SHOW WEIGHT TIMEOUT
ADJUST SPIN SPEED ALLOWED	PC5 BLOCKING OF HEATING
DISPLAY REMAINING TIME	PC5 BLOCKING OF SPINNING
DISPLAY ACTUAL TEMPERATURE	HEAT 2 AS STANDARD
DISPLAY ACTUAL SPEED	SERVICE ALARM HOURS
MACHINE NOT HEATED	BUZZER TIMEOUT AT END
TEMPERATURE CONTROL OF WATER	BUZZER TIMEOUT AT PAUS
TEMPERATURE IN °C	ERROR, OVERFILLED
REPEAT PROGR. MODE QUESTION	PASSWORD ACTIVE
LOCKED STANDARD WASH PROGRAMS	CMIS ADDRESS
LEVEL QUICK COOL-DOWN	LEVEL IN MM ACTIVE
LEVEL UNBALANCE	START SLOW FILLING, HG
LEVEL LOW	OFFSET LEVEL, HG
LEVEL MEDIUM	READY



To select the "SETTINGS 1" function

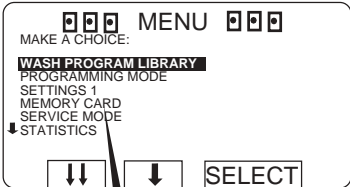

 If this menu is not currently displayed:
 Press  repeatedly.

 Press  to highlight "GO TO THE MENU".

 Press SELECT.



 Press  twice...

 ... to highlight "SETTINGS 1".

 Press SELECT.

Password

To open the function without a password



SELECT Press SELECT.

To enter a password the first time



1	2	3
4	5	6
7	8	9
0		

Enter a password consisting of any four digits.

SELECT Press SELECT.

To open the function using a password



If the function has already been password-protected, you will see an asterisk here instead of the word SELECT.

1	2	3
4	5	6
7	8	9
0		

Use the numeric keys to enter your four-digit password.
 Once the correct password has been entered, the display will show  and **SELECT**.

SELECT Press SELECT.

Password protection or not?

It is for you to decide whether or not the functions SETTINGS 1 and PROGRAMMING will be password-protected. Please note that if you do decide to implement password protection for either of them, then access to **both** these functions will be by means of the same password.

The password consists of any four digits, chosen by you.

At any time you can change this password, or remove password protection from these functions.

Password set or not set

In Configuration 1, it is possible to select whether or not to use a password.

If the password is not used, the password explanations can be disregarded.

To change the password

1	2	3
4	5	6
7	8	9
0		

Enter your four-digit password.

Once the correct password has been entered, the display will show  and **SELECT**.



Press .

1	2	3
4	5	6
7	8	9
0		

Enter the new four-digit password.

SELECT

Press **SELECT**.

To remove the password protection

1	2	3
4	5	6
7	8	9
0		

Enter your four-digit password.

Once the correct password has been entered, the display will show  and **SELECT**.



Press .

1	2	3
4	5	6
7	8	9
0		

Enter four noughts (0000).

SELECT

Press **SELECT**.

Variables under "SETTINGS 1"

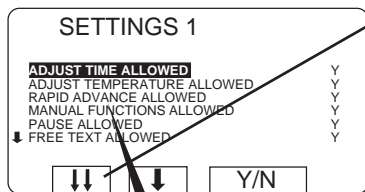

When the top line of a menu is highlighted you have the option of scrolling down through the menu faster by pressing **↓ ↓**. When you do, the next portion of the menu is displayed, with its last line highlighted.

ADJUST TIME ALLOWED	Y
ADJUST TEMPERATURE ALLOWED	Y
RAPID ADVANCE ALLOWED	Y
SHOW WEIGHT ALLOWED	Y
WATER REDUCTION NOT ALLOWED	Y
MANUAL FUNCTIONS ALLOWED	Y
PAUSE ALLOWED	Y
FREE TEXT ALLOWED	Y
CHANGE WASH PROGRAM ALLOWED	Y
AUTO RESTART ALLOWED	Y
ADJUST SPIN SPEED ALLOWED.	Y
DISPLAY REMAINING TIME	Y
DISPLAY ACTUAL TEMPERATURE	Y
DISPLAY ACTUAL SPEED	Y
MACHINE NOT HEATED	N
TEMPERATURE CONTROL OF WATER	Y
TEMPERATURE IN °C	Y
REPEAT PROGR. MODE QUESTION	N
LOCKED STANDARD WASH PROGRAMS	N
LEVEL QUICK COOL-DOWN	175
LEVEL UNBALANCE	0
LEVEL LOW	135
LEVEL MEDIUM	150
LEVEL HIGH	175
MIDDEL TEMPERATURE COOL-DOWN	70° C
DEFAULT MOTOR ON TIME	0:12
DEFAULT MOTOR OFF TIME	0:03
FLUSH DELAY TIME	0:06
FLUSH ON TIME	0:10
BUZZER ON BUTTON	Y
MAX FILLING TIME	10:00
MAX HEATING TIME	10:00
SHOW WEIGHT TIMEOUT	0:20
PC5 BLOCKING OF HEATING	N
PC5 BLOCKING OF SPINNING	Y
HEAT 2 AS STANDARD	Y
SERVICE ALARM HOURS	Y
BUZZER TIMEOUT AT END	Y
BUZZER TIMEOUT AT PAUS	Y
ERROR, OVERFILLED	Y
PASSWORD ACTIVE	Y
CMIS ADDRESS	Y
LEVEL IN MM ACTIVE	Y
START SLOW FILLING, HG	Y
OFFSET LEVEL, HG	Y
READY	

Answer the questions using the function key or the numeric keys.

Different types of question

The questions in the various modules are of two different types, each of which needs to be answered in a different way:

Yes/No questions

The function key display shows **Y/N**, which is a toggle function (the letter to the right of the highlighted question toggles between **N** and **Y** each time it is pressed).

Times, temperatures, water levels

To answer these questions, use the numeric keys. The number of digits required will vary. If you make a mistake while entering digits, delete it by pressing **ERASE** one or more times.

No confirmation of value entered

Once you have entered the right value, you simply move on to the next by pressing **↓**. There is no enter or return key to press to confirm each value.

To alter the value for a question you have already answered

Press **↑** to highlight the question you want, then simply change the value.

Your changes can affect program operation

If you have answered any of the first 11 variables in the menu with **N** (No), and later during program operation you attempt to activate one of these, a message equivalent to "FUNCTION NOT ALLOWED" will appear on the display. You can then press any key to return to normal program operation.

Confirm changes before you exit Settings 1

If you have changed any of the variables, this change must be confirmed when you exit Settings 1. To do this you have to use a strap to short-circuit two terminals on the CPU board, see section headed "To conclude making changes in variables under SETTINGS 1".



Yes/No question



Times, temperatures, levels.



Press **↓** to move on to the next question.



You can go back and change a question you have answered already by pressing **↑** repeatedly. Then simply change the value in the normal way.



ADJUST TIME ALLOWED	Y
ADJUST TEMPERATURE ALLOWED	Y
RAPID ADVANCE ALLOWED	Y
SHOW WEIGHT ALLOWED	Y
WATER REDUCTION NOT ALLOWED	Y
MANUAL FUNCTIONS ALLOWED	Y
PAUSE ALLOWED	Y
FREE TEXT ALLOWED	Y
CHANGE WASH PROGRAM ALLOWED	Y
AUTO RESTART ALLOWED	Y
ADJUST SPIN SPEED ALLOWED.	Y
DISPLAY REMAINING TIME	Y
DISPLAY ACTUAL TEMPERATURE	Y
DISPLAY ACTUAL SPEED	Y
MACHINE NOT HEATED	N

Y/N Answer Yes (Y) or No (N).

Press  .

ADJUST TIME ALLOWED	Y
ADJUST TEMPERATURE ALLOWED	Y
RAPID ADVANCE ALLOWED	Y
SHOW WEIGHT ALLOWED	Y
WATER REDUCTION NOT ALLOWED	Y
MANUAL FUNCTIONS ALLOWED	Y
PAUSE ALLOWED	Y
FREE TEXT ALLOWED	Y
CHANGE WASH PROGRAM ALLOWED	Y
AUTO RESTART ALLOWED	Y
ADJUST SPIN SPEED ALLOWED.	Y
DISPLAY REMAINING TIME	Y
DISPLAY ACTUAL TEMPERATURE	Y
DISPLAY ACTUAL SPEED	Y
MACHINE NOT HEATED	N

Y/N Answer Yes (Y) or No (N).

Press  .

Altering "step time" allowed

Here you determine if manual adjustment of the remaining "step time" (by using  to move to the line for "STEP TIME" then entering a new time) will be allowed.

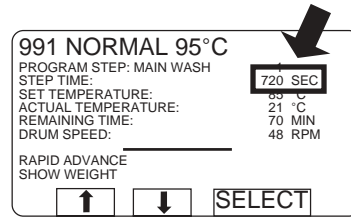

If you answer **Yes (Y)**:

Changing the "step time" during program operation will be allowed.

If you answer **No (N)**:

Changing the "step time" during a wash program will not be allowed.

Altering temperature allowed

Here you determine if manual adjustment of the wash temperature (by using  to move to the line for "SET TEMPERATURE" then entering a new wash temperature) will be allowed.

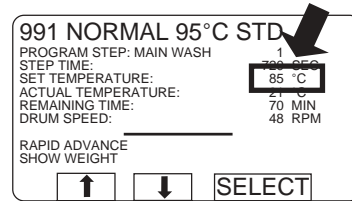

The following functions determine how the temperature may be altered:

ADJUST TEMPERATURE ALLOWED

If you answer **Yes (Y)**:

Altering the temperature will be allowed.

If you answer **No (N)**:

Altering this temperature parameter will not be allowed.

The following two functions are under "SETTINGS 2":

TEMPERATURE INCREASE ALLOWED

which determines whether it is allowed to alter the temperature parameter to higher than the original temperature in the wash program or not.

MAX ADJUST TEMPERATURE

which determines the upper temperature limit for manual temperature adjustment.

ADJUST TIME ALLOWED	Y
ADJUST TEMPERATURE ALLOWED	Y
RAPID ADVANCE ALLOWED	Y
SHOW WEIGHT ALLOWED	Y
WATER REDUCTION NOT ALLOWED	Y
MANUAL FUNCTIONS ALLOWED	Y
PAUSE ALLOWED	Y
FREE TEXT ALLOWED	Y
CHANGE WASH PROGRAM ALLOWED	Y
AUTO RESTART ALLOWED	Y
ADJUST SPIN SPEED ALLOWED.	Y
DISPLAY REMAINING TIME	Y
DISPLAY ACTUAL TEMPERATURE	Y
DISPLAY ACTUAL SPEED	Y
MACHINE NOT HEATED	N

Y/N Answer Yes (Y) or No (N).

Press .

Rapid advance allowed

Here you determine whether it is allowed to use rapid advance forwards or backwards through the wash program during program operation.

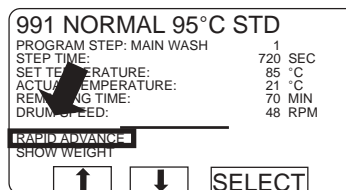

If you answer **Yes (Y)**:

Rapid advance is allowed.

If you answer **No (N)**:

Rapid advance is not allowed. If you have answered N (No), and subsequently during program operation you wish to terminate a program before it has ended, press the emergency stop button.

ADJUST TIME ALLOWED	Y
ADJUST TEMPERATURE ALLOWED	Y
RAPID ADVANCE ALLOWED	Y
SHOW WEIGHT ALLOWED	Y
WATER REDUCTION NOT ALLOWED	Y
MANUAL FUNCTIONS ALLOWED	Y
PAUSE ALLOWED	Y
FREE TEXT ALLOWED	Y
CHANGE WASH PROGRAM ALLOWED	Y
AUTO RESTART ALLOWED	Y
ADJUST SPIN SPEED ALLOWED.	Y
DISPLAY REMAINING TIME	Y
DISPLAY ACTUAL TEMPERATURE	Y
DISPLAY ACTUAL SPEED	Y
MACHINE NOT HEATED	N

Y/N Answer Yes (Y) or No (N).

Press .

Show weight allowed

Here you determine whether the menu line showing actual weight will be displayed or not.

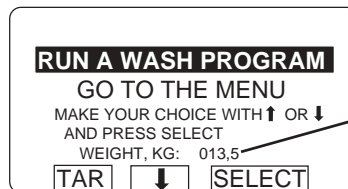

If you answer **Yes (Y)**:

Menu line showing current weight will be displayed.

If you answer **No (N)**:

Menu line showing current weight will not be displayed.

For machines with weight measurement installed only!

ADJUST TIME ALLOWED	Y
ADJUST TEMPERATURE ALLOWED	Y
RAPID ADVANCE ALLOWED	Y
SHOW WEIGHT ALLOWED	Y
WATER REDUCTION NOT ALLOWED	
MANUAL FUNCTIONS ALLOWED	Y
PAUSE ALLOWED	Y
FREE TEXT ALLOWED	Y
CHANGE WASH PROGRAM ALLOWED	Y
AUTO RESTART ALLOWED	Y
ADJUST SPIN SPEED ALLOWED.	Y
DISPLAY REMAINING TIME	Y
DISPLAY ACTUAL TEMPERATURE	Y
DISPLAY ACTUAL SPEED	Y
MACHINE NOT HEATED	N

Water reduction not allowed

If the weight measurement function is installed, the water level will be reduced automatically if the machine does not have a full load.

Here you determine whether it will be possible to switch off the water level reduction during a wash program, using the function "WATER REDUCTION NOT ALLOWED".

If you answer **Yes (Y)**:
The function "WATER REDUCTION NOT ALLOWED" can be used.

If you answer **No (N)**:
The function "WATER REDUCTION NOT ALLOWED" **cannot** be used.

Y/N

Answer Yes (Y) or No (N).



Press .

ADJUST TIME ALLOWED	Y
ADJUST TEMPERATURE ALLOWED	Y
RAPID ADVANCE ALLOWED	Y
SHOW WEIGHT ALLOWED	Y
WATER REDUCTION NOT ALLOWED	Y
MANUAL FUNCTIONS ALLOWED	
PAUSE ALLOWED	Y
FREE TEXT ALLOWED	Y
CHANGE WASH PROGRAM ALLOWED	Y
AUTO RESTART ALLOWED	Y
ADJUST SPIN SPEED ALLOWED.	Y
DISPLAY REMAINING TIME	Y
DISPLAY ACTUAL TEMPERATURE	Y
DISPLAY ACTUAL SPEED	Y
MACHINE NOT HEATED	N

Manual functions allowed

Here you determine whether it will be possible to use certain functions manually during the wash program:

- Control water valves and drain valve
- Determine the highest extraction speed allowed
- Motor action after program end
- Control detergent valves

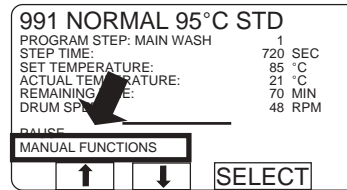

If you answer **Yes (Y)**:
These manual functions will be allowed.

If you answer **No (N)**:
These manual functions will not be allowed.

Y/N

Answer Yes (Y) or No (N).



Press .

ADJUST TIME ALLOWED	Y
ADJUST TEMPERATURE ALLOWED	Y
RAPID ADVANCE ALLOWED	Y
SHOW WEIGHT ALLOWED	Y
WATER REDUCTION NOT ALLOWED	Y
MANUAL FUNCTIONS ALLOWED	Y
PAUSE ALLOWED	Y
FREE TEXT ALLOWED	Y
CHANGE WASH PROGRAM ALLOWED	Y
AUTO RESTART ALLOWED	Y
ADJUST SPIN SPEED ALLOWED.	Y
DISPLAY REMAINING TIME	Y
DISPLAY ACTUAL TEMPERATURE	Y
DISPLAY ACTUAL SPEED	Y
MACHINE NOT HEATED	N

Y/N Answer Yes (Y) or No (N).

Press .

Pause allowed

Here you determine whether it is allowed to use the pause function during the wash program. This function will not work until the second time the program is run. Before that the line will be blank even if you have inserted Y (Yes) here.

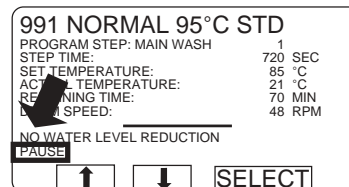

If you answer **Yes (Y)**:

The use of the pause function during the wash program will be allowed. Pause is selected either through the PAUSE function or by pressing .

If you answer **No (N)**:

The use of the pause function during the wash program will not be allowed. It is still possible, however, to pause using the  key.

ADJUST TIME ALLOWED	Y
ADJUST TEMPERATURE ALLOWED	Y
RAPID ADVANCE ALLOWED	Y
SHOW WEIGHT ALLOWED	Y
WATER REDUCTION NOT ALLOWED	Y
MANUAL FUNCTIONS ALLOWED	Y
PAUSE ALLOWED	Y
FREE TEXT ALLOWED	Y
CHANGE WASH PROGRAM ALLOWED	Y
AUTO RESTART ALLOWED	Y
ADJUST SPIN SPEED ALLOWED.	Y
DISPLAY REMAINING TIME	Y
DISPLAY ACTUAL TEMPERATURE	Y
DISPLAY ACTUAL SPEED	Y
MACHINE NOT HEATED	N

Y/N Answer Yes (Y) or No (N).

Press .

Display of free text about program allowed

Here you determine whether the display of free text about the wash program will be allowed.

Example of "free text", entered when the program is created.

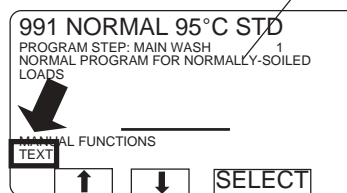

If you answer **Yes (Y)**:

Display of free text will be allowed.

If you answer **No (N)**:

Display of free text will not be allowed.

ADJUST TIME ALLOWED	Y
ADJUST TEMPERATURE ALLOWED	Y
RAPID ADVANCE ALLOWED	Y
SHOW WEIGHT ALLOWED	Y
WATER REDUCTION NOT ALLOWED	Y
MANUAL FUNCTIONS ALLOWED	Y
PAUSE ALLOWED	Y
FREE TEXT ALLOWED	Y
CHANGE WASH PROGRAM ALLOWED	Y
AUTO RESTART ALLOWED	Y
ADJUST SPIN SPEED ALLOWED.	Y
DISPLAY REMAINING TIME	Y
DISPLAY ACTUAL TEMPERATURE	Y
DISPLAY ACTUAL SPEED	Y
MACHINE NOT HEATED	N

Y/N Answer Yes (Y) or No (N).

Press  .

Changing wash program allowed

Here you determine whether it is allowed to change to a different wash program during program operation.

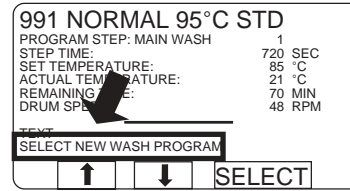

If you answer **Yes (Y)**:
Changing to a different wash program allowed.

If you answer **No (N)**:
Changing to a different wash program not allowed.

ADJUST TEMPERATURE ALLOWED	Y
RAPID ADVANCE ALLOWED	Y
SHOW WEIGHT ALLOWED	Y
WATER REDUCTION NOT ALLOWED	Y
MANUAL FUNCTIONS ALLOWED	Y
PAUSE ALLOWED	Y
FREE TEXT ALLOWED	Y
CHANGE WASH PROGRAM ALLOWED	Y
AUTO RESTART ALLOWED	Y
ADJUST SPIN SPEED ALLOWED.	Y
DISPLAY REMAINING TIME	Y
DISPLAY ACTUAL TEMPERATURE	Y
DISPLAY ACTUAL SPEED	Y
MACHINE NOT HEATED	N
TEMPERATURE CONTROL OF WATER	Y

Y/N Answer Yes (Y) or No (N).

Press  .

Automatic restart allowed

Here you determine whether automatic restart of a wash program is allowed.

Automatic restart means that the same program will be repeated the number of times entered. The program will restart immediately, and it will not be possible to open the door in between. If automatic restart has been programmed, the display will show the number of restarts left.

The function is mostly used for testing.

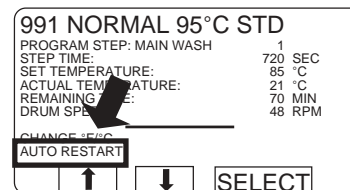

If you answer **Yes (Y)**:
Automatic restart will be allowed.

If you answer **No (N)**:
Automatic restart will not be allowed.

RAPID ADVANCE ALLOWED	Y
SHOW WEIGHT ALLOWED	Y
WATER REDUCTION NOT ALLOWED	Y
MANUAL FUNCTIONS ALLOWED	Y
PAUSE ALLOWED	Y
FREE TEXT ALLOWED	Y
CHANGE WASH PROGRAM ALLOWED	Y
AUTO RESTART ALLOWED	Y
ADJUST SPIN SPEED ALLOWED.	Y
DISPLAY REMAINING TIME	Y
DISPLAY ACTUAL TEMPERATURE	Y
DISPLAY ACTUAL SPEED	Y
MACHINE NOT HEATED	N
TEMPERATURE CONTROL OF WATER	Y

Y/N Answer Yes (Y) or No (N)..

Press .

Altering extraction speed allowed

Here you determine whether it is allowed to alter the extraction speed during the current extraction sequence by using to move to the DRUM SPEED line and entering a new value.

If you answer **Yes (Y)**:
Altering extraction speed will be allowed.

If you answer **No (N)**:
Altering extraction speed will not be allowed.

MANUAL FUNCTIONS ALLOWED	Y
PAUSE ALLOWED	Y
FREE TEXT ALLOWED	Y
CHANGE WASH PROGRAM ALLOWED	Y
AUTO RESTART ALLOWED	Y
ADJUST SPIN SPEED ALLOWED.	Y
DISPLAY REMAINING TIME	Y
DISPLAY ACTUAL TEMPERATURE	Y
DISPLAY ACTUAL SPEED	Y
MACHINE NOT HEATED	N
TEMPERATURE CONTROL OF WATER	Y
TEMPERATURE IN °C	Y
REPEAT Progr. MODE QUESTION	N
LOCKED STANDARD WASH PROGRAMS	N
LEVEL QUICK COOL-DOWN	175

Y/N Answer Yes (Y) or No (N)..

Press .

Display time left

Here you determine whether the time the program has left to run will be displayed during the program. This function will not work until the second time the program is run. Before that the line will be blank even if you have inserted Y (Yes) here.

The time displayed will be based on the average of the last five times the program was used.

If you answer **Yes (Y)**:
The time the program has left to run will be displayed.

If you answer **No (N)**:
The time the program has left to run will not be displayed.

MANUAL FUNCTIONS ALLOWED	Y
FREE TEXT ALLOWED	Y
CHANGE WASH PROGRAM ALLOWED	Y
AUTO RESTART ALLOWED	Y
ADJUST SPIN SPEED ALLOWED.	Y
DISPLAY REMAINING TIME	Y
DISPLAY ACTUAL TEMPERATURE	Y
DISPLAY ACTUAL SPEED	Y
MACHINE NOT HEATED	N
TEMPERATURE CONTROL OF WATER	Y
TEMPERATURE IN °C	Y
REPEAT PROGR. MODE QUESTION	N
LOCKED STANDARD WASH PROGRAMS	N
LEVEL QUICK COOL-DOWN	175
LEVEL UNBALANCE	0

Display actual temperature

Here you determine whether the actual water temperature will be displayed during the program.

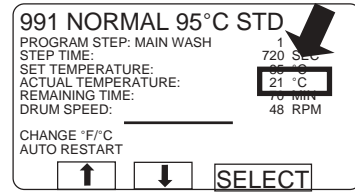

If you answer **Yes (Y)**:
Actual water temperature will be displayed.
If you answer **No (N)**:
Actual water temperature will not be displayed.

Y/N Answer Yes (Y) or No (N).
Press .

FREE TEXT ALLOWED	Y
CHANGE WASH PROGRAM ALLOWED	Y
AUTO RESTART ALLOWED	Y
ADJUST SPIN SPEED ALLOWED.	Y
DISPLAY REMAINING TIME	Y
DISPLAY ACTUAL TEMPERATURE	Y
DISPLAY ACTUAL SPEED	Y
MACHINE NOT HEATED	N
TEMPERATURE CONTROL OF WATER	Y
TEMPERATURE IN °C	Y
REPEAT PROGR. MODE QUESTION	N
LOCKED STANDARD WASH PROGRAMS	N
LEVEL QUICK COOL-DOWN	175
LEVEL UNBALANCE	0
LEVEL LOW	135

Display actual speed

Here you determine whether the actual drum speed will be displayed during the program.

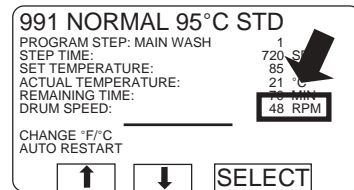

If you answer **Yes (Y)**:
Actual drum speed will be displayed.
If you answer **No (N)**:
Actual drum speed will not be displayed.

Y/N Answer Yes (Y) or No (N).
Press .

CHANGE WASH PROGRAM ALLOWED	Y
AUTO RESTART ALLOWED	Y
ADJUST SPIN SPEED ALLOWED.	Y
DISPLAY REMAINING TIME	Y
DISPLAY ACTUAL TEMPERATURE	Y
DISPLAY ACTUAL SPEED	Y
MACHINE NOT HEATED	N
TEMPERATURE CONTROL OF WATER	Y
TEMPERATURE IN °C	Y
REPEAT PROGR. MODE QUESTION	N
LOCKED STANDARD WASH PROGRAMS	N
LEVEL QUICK COOL-DOWN	175
LEVEL UNBALANCE	0
LEVEL LOW	135
LEVEL MEDIUM	150

Answer Yes (Y) or No (N)..

Press .

AUTO RESTART ALLOWED	Y
ADJUST SPIN SPEED ALLOWED.	Y
DISPLAY REMAINING TIME	Y
DISPLAY ACTUAL TEMPERATURE	Y
DISPLAY ACTUAL SPEED	Y
MACHINE NOT HEATED	N
TEMPERATURE CONTROL OF WATER	Y
TEMPERATURE IN °C	Y
REPEAT PROGR. MODE QUESTION	N
LOCKED STANDARD WASH PROGRAMS	N
LEVEL QUICK COOL-DOWN	175
LEVEL UNBALANCE	0
LEVEL LOW	135
LEVEL MEDIUM	150
LEVEL HIGH	175

Answer Yes (Y) or No (N).

Press .

Machine not heated

Here you determine if the machine is to heat the water to the required temperature before the time the wash sequence starts, or if the wash time of the sequence is to begin directly after water filling.

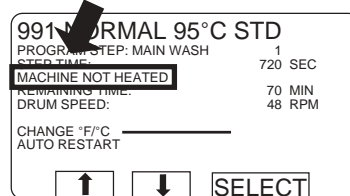

If you answer **Yes (Y)**:

The machine will not wait for the water to heat, but will begin to count down the time of on the wash sequence immediately.

The temperature of the water will, however, still be monitored and adjusted during filling if the answer Yes has been inserted for the question "TEMPERATURE CONTROL OF WATER" (see next question).

If the answer "Yes" is in place (Yes is the default) for the question "HEATING RELAY ON WHEN NOT HEATED" (see "Settings 2") the heating relay (if machine is equipped with one) will switch on. This means you can heat the water while wash action is in progress. If you do not want the heating relay to switch on, you must insert the answer "No" for the question "HEATING RELAY ON WHEN NOT HEATED".

If you answer **No (N)**:

The machine will heat the water to the set temperature before the count down of the wash sequence begins. The temperature values will be shown on the display (if you have "allowed" their display).

Temperature control of water

Here you determine whether the machine will monitor and adjust the water temperature during filling, by opening and closing the cold and hot water valves.

If you answer **Yes (Y)**:

This function will be activated.

If you answer **No (N)**:

Temperature control not activated. Both the hot and the cold water valves will be opened until the machine has filled to the correct level.

ADJUST SPIN SPEED ALLOWED.	Y
DISPLAY REMAINING TIME	Y
DISPLAY ACTUAL TEMPERATURE	Y
DISPLAY ACTUAL SPEED	Y
MACHINE NOT HEATED	N
TEMPERATURE CONTROL OF WATER	Y
TEMPERATURE IN °C	Y
REPEAT PROGR. MODE QUESTION	N
LOCKED STANDARD WASH PROGRAMS	N
LEVEL QUICK COOL-DOWN	175
LEVEL UNBALANCE	0
LEVEL LOW	135
LEVEL MEDIUM	150
LEVEL HIGH	175
MIDDLE TEMPERATURE COOL -DOWN	70 °C

Temperature in °C

Here you determine if all temperatures are to be shown in °C or °F.

If you answer **Yes (Y)**:
All temperatures will be shown in °C.

If you answer **No (N)**:
All temperatures will be shown in °F.

Y/N Answer Yes (Y) or No (N).

 Press  .

DISPLAY REMAINING TIME	Y
DISPLAY ACTUAL TEMPERATURE	Y
DISPLAY ACTUAL SPEED	Y
MACHINE NOT HEATED	N
TEMPERATURE CONTROL OF WATER	Y
TEMPERATURE IN °C	Y
REPEAT PROGR. MODE QUESTION	N
LOCKED STANDARD WASH PROGRAMS	N
LEVEL QUICK COOL-DOWN	175
LEVEL UNBALANCE	0
LEVEL LOW	135
LEVEL MEDIUM	150
LEVEL HIGH	175
MIDDLE TEMPERATURE COOL-DOWN	70 °C
DEFAULT MOTOR ON TIME	0:12

Repeat program mode question

Here you determine whether you (or the user) will be given the chance to select either Standard or Advanced mode for each new program module you are programming, if you start programming in Standard mode.

If you answer **Yes (Y)**:
You can select either Standard or Advanced mode for each new program module you program.

If you answer **No (N)**:
All modules must be programmed using either Standard mode or Advanced mode consistently, whichever is selected when you begin programming.

Y/N Answer Yes (Y) or No (N).

 Press  .

DISPLAY ACTUAL TEMPERATURE	Y
DISPLAY ACTUAL SPEED	Y
MACHINE NOT HEATED	N
TEMPERATURE CONTROL OF WATER	Y
TEMPERATURE IN °C	Y
REPEAT PROGR. MODE QUESTION	N
LOCKED STANDARD WASH PROGRAMS	N
LEVEL QUICK COOL-DOWN	175
LEVEL UNBALANCE	0
LEVEL LOW	135
LEVEL MEDIUM	150
LEVEL HIGH	175
MIDDLE TEMPERATURE COOL-DOWN 70 °C	
DEFAULT MOTOR ON TIME	0:12
DEFAULT MOTOR OFF TIME	0:03

No access to standard programs

Here you determine whether the user will have access to the machine's standard programs (numbered 991-999) or not.

If you answer **Yes (Y)**:
The user will not have access to the standard programs.

If you answer **No (N)**:
The user will have access to the standard programs.

Y/N Answer Yes (Y) or No (N).

Press **↓**.

DISPLAY ACTUAL SPEED	Y
MACHINE NOT HEATED	N
TEMPERATURE CONTROL OF WATER	Y
TEMPERATURE IN °C	Y
REPEAT PROGR. MODE QUESTION	N
LOCKED STANDARD WASH PROGRAMS	N
LEVEL QUICK COOL- DOWN	175
LEVEL UNBALANCE	0
LEVEL LOW	135
LEVEL MEDIUM	150
LEVEL HIGH	175
MIDDLE TEMPERATURE COOL-DOWN 70 °C	
DEFAULT MOTOR ON TIME	0:12
DEFAULT MOTOR OFF TIME	0:03
FLUSH DELAY TIME	0:06

Water level for quick cool-down

Here you determine the level to which the machine fills with cold water for quick cool-down.

When you are creating a wash program, in the module "COOL-DOWN" there is an option for programming "QUICK COOL-DOWN".

Quick cool-down means that the machine will fill with cold water to a higher level.

This function is used mainly for reducing the temperature of the water before it is discharged.

For information on the levels used for the various machines, see the manual "Programming, PCS Program Control Unit".

Use the numeric keys to enter the value.

1 2 3
4 5 6
7 8 9
0

If you make a mistake while entering digits:
Press **ERASE**.

When you have finished:
Press **↓**.

MACHINE NOT HEATED	N
TEMPERATURE CONTROL OF WATER	Y
TEMPERATURE IN °C	Y
REPEAT PROGR. MODE QUESTION	N
LOCKED STANDARD WASH PROGRAMS	N
LEVEL QUICK COOL-DOWN	175
LEVEL UNBALANCE	0
LEVEL LOW	135
LEVEL MEDIUM	150
LEVEL HIGH	175
MIDDLE TEMPERATURE COOL-DOWN 70 °C	
DEFAULT MOTOR ON TIME	0:12
DEFAULT MOTOR OFF TIME	0:03
FLUSH DELAY TIME	0:06
FLUSH ON TIME	0:10

Water level after unbalance halt

Here you determine the water level to which the machine fills after a halt in extraction due to unbalance.

If the machine's unbalance-sensing equipment is activated when extraction begins, that extraction will halt and a new attempt will begin. If you want the drum to be filled with water to a certain level before the drain valve opens and the machine makes a fresh attempt at extraction, you can set that level here. Level 0 means that the drum will not fill.

For information on the levels used for the various machines, see the manual "Programming, PCS Program Control Unit".

Use the numeric keys to enter the value.



If you make a mistake while entering digits:

Press **ERASE**.

When you have finished:



Press .

TEMPERATURE IN °C	Y
REPEAT PROGR. MODE QUESTION	N
LOCKED STANDARD WASH PROGRAMS	N
LEVEL QUICK COOL-DOWN	175
LEVEL UNBALANCE	0
LEVEL LOW	135
LEVEL MEDIUM	150
LEVEL HIGH	175
MIDDLE TEMPERATURE COOL-DOWN 70 °C	
DEFAULT MOTOR ON TIME	0:12
DEFAULT MOTOR OFF TIME	0:03
FLUSH DELAY TIME	0:06
FLUSH ON TIME	0:10
BUZZER ON BUTTON	Y
MAX FILLING TIME	10:00

Low / Medium / High levels

Here you determine the water levels which are to correspond to L (low), M (medium) and H (high). These levels are used when you are programming in Standard mode.

For information on the levels used for the various machines, see the manual "Programming, PCS Program Control Unit".

Use the numeric keys to enter the value.



If you make a mistake while entering digits:

Press **ERASE**.

When you have finished:



Press .

LEVEL QUICK COOL-DOWN	175
LEVEL UNBALANCE	0
LEVEL LOW	135
LEVEL MEDIUM	150
LEVEL HIGH	175
MIDDLE TEMPERATURE COOL-DOWN 70 °C	
DEFAULT MOTOR ON TIME	0:12
DEFAULT MOTOR OFF TIME	0:03
FLUSH DELAY TIME	0:06
FLUSH ON TIME	0:10
BUZZER ON BUTTON	Y
MAX FILLING TIME	10:00
MAX HEATING TIME	10:00
SHOW WEIGHT TIMEOUT	0:20
PC5 BLOCKING OF HEATING	N
PC5 BLOCKING OF SPINNING	Y
HEAT 2 AS STANDARD	Y
SERVICE ALARM HOURS	Y



Use the numeric keys to enter the value.

If you make a mistake while entering digits:

Press **ERASE**.



When you have finished:

Press .

LEVEL UNBALANCE	0
LEVEL LOW	135
LEVEL MEDIUM	150
LEVEL HIGH	175
MIDDLE TEMPERATURE COOL-DOWN 70 °C	
DEFAULT MOTOR ON TIME	0:12
DEFAULT MOTOR OFF TIME	0:03
FLUSH DELAY TIME	0:06
FLUSH ON TIME	0:10
BUZZER ON BUTTON	Y
MAX FILLING TIME	10:00
MAX HEATING TIME	10:00
SHOW WEIGHT TIMEOUT	0:20
PC5 BLOCKING OF HEATING	N
PC5 BLOCKING OF SPINNING	Y
HEAT 2 AS STANDARD	Y
SERVICE ALARM HOURS	Y



Use the numeric keys to enter the value.

If you make a mistake while entering digits:

Press **ERASE**.



When you have finished:

Press .

Middle temperature cool-down

Here you determine the middle temperature for cool-down.

When creating a new wash program you can, to prevent creasing of the load, use the COOL-DOWN module to achieve controlled cool-down of the water in the drum. The cool-down sequence is divided into two stages:

- 1 wash temperature to middle temperature**
Throughout this stage the machine will monitor the cool-down rate, to ensure it does not exceed the cool-down rate set (4°C per minute when the machine leaves the factory). If the rate set is exceeded, no water will be added until the mean value is acceptable again.
- 2 middle temperature to final temperature**
The rate of cool-down is not monitored during this stage. The valve opens and shuts as you have programmed it to do.

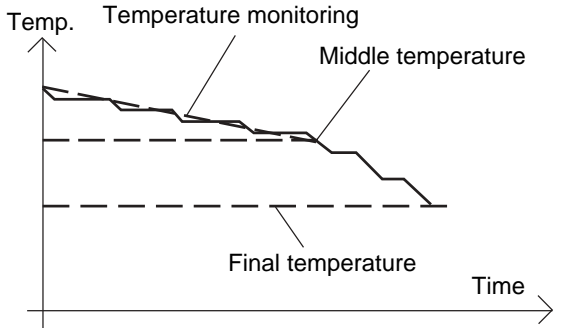

Default motor on-time / off-time

Here you determine the machine default times for motor rotation, both "on-time" and "off-time".

Under certain circumstances during a wash program, e.g when the machine starts up again after a halt in extraction due to imbalance, the machine cannot find the "on-time" and "off-time" values for its motor action in the current wash program. That is when it needs to be able to find and use the default "on-time" and "off-time" values stored here.

The values shown are those recommended by the supplier.

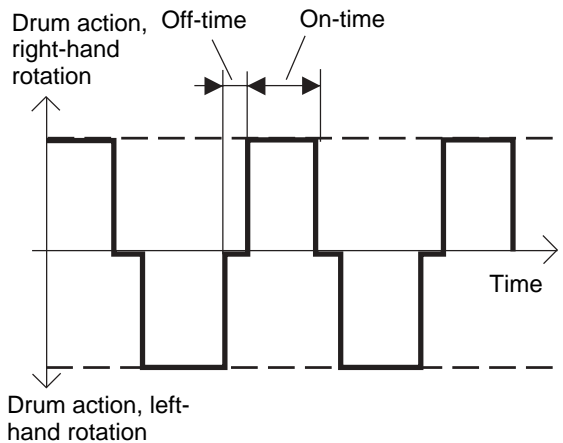

LEVEL UNBALANCE	0
LEVEL LOW	135
LEVEL MEDIUM	150
LEVEL HIGH	175
MIDDLE TEMPERATURE COOL-DOWN 70 °C	
DEFAULT MOTOR ON TIME	0:12
DEFAULT MOTOR OFF TIME	0:03
FLUSH DELAY TIME	0:06
FLUSH ON TIME	0:10
BUZZER ON BUTTON	Y
MAX FILLING TIME	10:00
MAX HEATING TIME	10:00
SHOW WEIGHT TIMEOUT	0:20
PC5 BLOCKING OF HEATING	N
PC5 BLOCKING OF SPINNING	Y
HEAT 2 AS STANDARD	Y
SERVICE ALARM HOURS	Y

Flush times
 Here you determine times relating to flushing clean the supply lines of an external system for liquid detergent: the delay time and the length of time "on".

Use the numeric keys to enter the value.

 If you make a mistake while entering digits:
 Press ERASE.

When you have finished:
 Press .

LEVEL UNBALANCE	0
LEVEL LOW	135
LEVEL MEDIUM	150
LEVEL HIGH	175
MIDDLE TEMPERATURE COOL-DOWN 70 °C	
DEFAULT MOTOR ON TIME	0:12
DEFAULT MOTOR OFF TIME	0:03
FLUSH DELAY TIME	0:06
FLUSH ON TIME	0:10
BUZZER ON BUTTON	Y
MAX FILLING TIME	10:00
MAX HEATING TIME	10:00
SHOW WEIGHT TIMEOUT	0:20
PC5 BLOCKING OF HEATING	N
PC5 BLOCKING OF SPINNING	Y
HEAT 2 AS STANDARD	Y
SERVICE ALARM HOURS	Y

Key click on
 Here you determine whether or not there will be an audible click (or beep) each time a key on the PCU control panel is pressed.
 If you answer **Yes (Y)**:
 Click (beep) for each key press.
 If you answer **No (N)**:
 No click or beep audible when keys pressed.

Answer Yes (Y) or No (N).
 Press .

BUZZER ON BUTTON	Y
MAX FILLING TIME	10:00
MAX HEATING TIME	10:00
SHOW WEIGHT TIMEOUT	0:20
PC5 BLOCKING OF HEATING	N
PC5 BLOCKING OF SPINNING	Y
HEAT 2 AS STANDARD	Y
SERVICE ALARM HOURS	Y
BUZZER TIMEOUT AT END	Y
BUZZER TIMEOUT AT PAUS	Y
ERROR, OVERFILLED	Y
PASSWORD ACTIVE	Y
CMIS ADDRESS	0
LEVEL IN MM ACTIVE	Y
START SLOW FILLING, HG	10
OFFSET LEVEL, HG	2
READY	

Maximum filling time

Here you determine the maximum time to be allowed for filling the machine with water to the level set.

If the correct level has not been reached within this time, the error message "NO WATER" will appear on the display.



Use the numeric keys to enter the value.

If you make a mistake while entering digits:

Press **ERASE**.



When you have finished:

Press .

BUZZER ON BUTTON	Y
MAX FILLING TIME	10:00
MAX HEATING TIME	10:00
SHOW WEIGHT TIMEOUT	0:20
PC5 BLOCKING OF HEATING	N
PC5 BLOCKING OF SPINNING	Y
HEAT 2 AS STANDARD	Y
SERVICE ALARM HOURS	Y
BUZZER TIMEOUT AT END	Y
BUZZER TIMEOUT AT PAUS	Y
ERROR, OVERFILLED	Y
PASSWORD ACTIVE	Y
CMIS ADDRESS	0
LEVEL IN MM ACTIVE	Y
START SLOW FILLING, HG	10
OFFSET LEVEL, HG	2
READY	

Maximum heating time

Here you determine the maximum time to be allowed to heat the water a certain number of degrees (the number of degrees can be set as a parameter via the function "MINIMUM TEMPERATURE INCREASE" under "SETTINGS 2").

If the water has not been heated within this time, the error message "NO HEATING" will appear on the display.



Use the numeric keys to enter the value.

If you make a mistake while entering digits:

Press **ERASE**.



When you have finished:

Press .

BUZZER ON BUTTON	Y
MAX FILLING TIME	10:00
MAX HEATING TIME	10:00
SHOW WEIGHT TIMEOUT	0:20
PC5 BLOCKING OF HEATING	N
PC5 BLOCKING OF SPINNING	Y
HEAT 2 AS STANDARD	Y
SERVICE ALARM HOURS	Y
BUZZER TIMEOUT AT END	Y
BUZZER TIMEOUT AT PAUS	Y
ERROR, OVERFILLED	Y
PASSWORD ACTIVE	Y
CMIS ADDRESS	0
LEVEL IN MM ACTIVE	Y
START SLOW FILLING, HG	10
OFFSET LEVEL, HG	2
READY	

Show weight timeout

Here you determine the length of time the weight will be displayed, before the normal display is restored.



Weight display mode



Use the numeric keys to enter the value.

If you make a mistake while entering digits:

Press **ERASE**.



When you have finished:

Press .

BUZZER ON BUTTON	Y
MAX FILLING TIME	10:00
MAX HEATING TIME	10:00
SHOW WEIGHT TIMEOUT	0:20
PC5 BLOCKING OF HEATING	N
PC5 BLOCKING OF SPINNING	Y
HEAT 2 AS STANDARD	Y
SERVICE ALARM HOURS	Y
BUZZER TIMEOUT AT END	Y
BUZZER TIMEOUT AT PAUS	Y
ERROR, OVERFILLED	Y
PASSWORD ACTIVE	Y
CMIS ADDRESS	0
LEVEL IN MM ACTIVE	Y
START SLOW FILLING, HG	10
OFFSET LEVEL, HG	2
READY	

PC5, Power Control

Here you determine whether input X15 on I/O PCB 1 (external pause signal) will have the "external pause signal" function (for this, the letter "N" (No) should be inserted on both option lines), or the Power Control (PC5) function. For detailed instructions on PC5 connection and settings, see relevant manual section.



Answer Yes (Y) or No (N).



Press .

BUZZER ON BUTTON	Y
MAX FILLING TIME	10:00
MAX HEATING TIME	10:00
SHOW WEIGHT TIMEOUT	0:20
PC5 BLOCKING OF HEATING	N
PC5 BLOCKING OF SPINNING	Y
HEAT 2 AS STANDARD	Y
SERVICE ALARM HOURS	Y
BUZZER TIMEOUT AT END	Y
BUZZER TIMEOUT AT PAUS	Y
ERROR, OVERFILLED	Y
PASSWORD ACTIVE	Y
CMIS ADDRESS	0
LEVEL IN MM ACTIVE	Y
START SLOW FILLING, HG	10
OFFSET LEVEL, HG	2
READY	

Relay for steam as standard

Here you decide if the machine should heat with steam or el. Yes (Y) the machine will heat with steam (standard) and No (N) the machine will heat with el.

Y/N Answer Yes (Y) or No (N).

Press  .

SERVICE ALARM HOURS	0
---------------------	---

Service interval

Here you determine the interval between service interventions on the machine.

The statistics function of the programme unit contains a counter that can be reset to show the number of hours of effective washing on the machine since the last service intervention.



STATISTICS		
TOTAL RUN TIME HOURS		0
HOURS SINCE LAST SERVICE		0
LAST 5 ERROR CODES	PROGRAM	HOURS
08 NO HEAT	991	0
08 NO HEAT	996	0
08 NO HEAT	993	0
08 NO HEAT	991	0
08 NO HEAT	991	0



*  READY







When the service technician has serviced the machine, this counter is reset.

When the time on the counter exceeds the programmed interval, "S" is displayed in the lower, left corner of the display indicating the need for Service.



991 NORMAL 95°C	
PROGRAM STEP: MAIN WASH	1
STEP TIME:	720 SEC
SET TEMPERATURE:	85 °C
ACTUAL TEMPERATURE:	21 °C
REMAINING TIME:	70 MIN
DRUM SPEED:	48 RPM
RAPID ADVANCE	
PAUSE	

 S   SELECT

   Use the numeric keys to enter the value.

  
  
 If you make a mistake while entering digits:

Press ERASE.

 When you have finished:
 Press  .

BUZZER TIMEOUT AT END 0:20

Buzzer length at programme end

Here you determine for how long the buzzer should sound at the end of the programme unless it is not turned off manually.

When programming the main data for a washing programme, it is possible to select whether or not to sound the buzzer at the programme end. The buzzer is switched off by pressing a function button on the control panel.

1 2 3 Use the numeric keys to enter the value.

4 5 6

7 8 9

0

If you make a mistake while entering digits:

Press ERASE.



When you have finished:

Press .

BUZZER TIMEOUT AT PAUS 0:10

Buzzer length at pause

Here you determine for how long the buzzer should sound at a programmed pause unless it is not turned off manually.

When programming a washing programme, it is possible to select whether or not to pause and sound the buzzer for each washing module before that module starts. The buzzer is switched off by pressing a function button on the control panel.

1 2 3 Use the numeric keys to enter the value.

4 5 6

7 8 9

0

If you make a mistake while entering digits:

Press ERASE.



When you have finished:

Press .

PASSWORD ACTIVE	Y
-----------------	---

Password active
Here you determine whether or not to set a password according to the explanations.

CMIS ADDRESS	0
--------------	---

CMIS address
Here you can give the machine a unique address when connected to the CMIS system. 0 = inactive
Allowed values = 1-127.

LEVEL IN MM ACTIVE	Y
--------------------	---

Level in mm active
Y(es) = Pressure sensor system for water filling active.
N(o) = Water filling will be made on weight.

START SLOW FILLING, HG

Y

Start slow filling, hg

When filling on weight, detergent valve 3 will be used to finalize the washer filling. Detergent valve 3 will be opened given value before the final level is reached.

OFFSET LEVEL, HG

Y

Offset level, hg

Gives value will be subtracted from programing water level before water filling starts. Only when filling on weight.

To conclude making changes in variables under "SETTINGS 1"

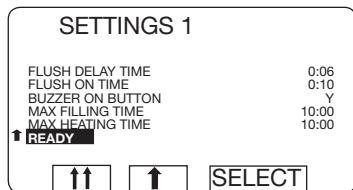

Press to highlight **READY**.

Insert a suitable strap to short-circuit terminals X7:1-2 on the CPU circuit board.

SELECT

Press **SELECT**.

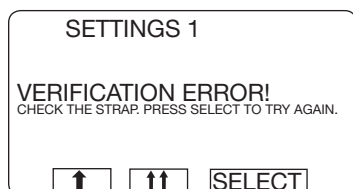

The display illustrated left will appear if you fail to insert the strap to short-circuit terminals X7:1-2.

Check that the strap between X7:1-2 is intact and in place.

Press **SELECT** and try again.



The variables will now have been stored in the PCU.

Remove the strap between terminals X7:1-2 on the CPU circuit board.

SELECT

Press **SELECT**.

To prevent inadvertent changes in variables

If you have changed any variables under "Settings 1", when you have finished keying in the changes, you need to insert a strap between two terminals on the CPU circuit board to register the changes in the CPU.

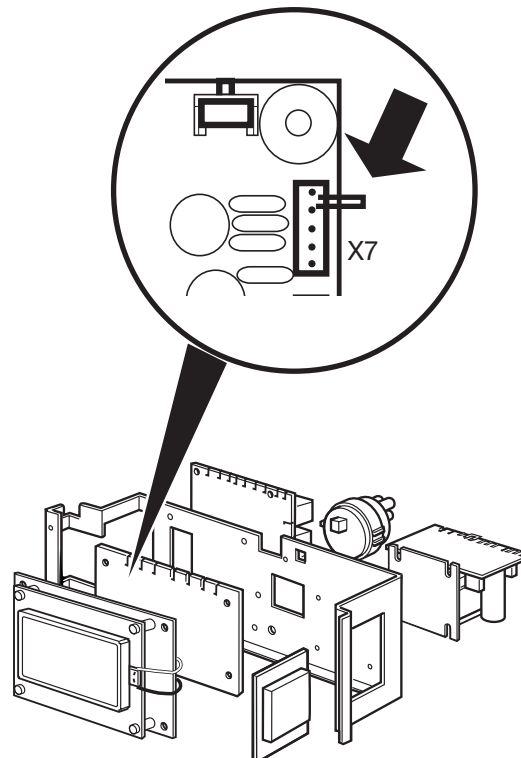

WARNING!



Use a short circuit jumper when strapping pin X7:1-2.

Do not use a screwdriver or similar as short circuiting a pin to ground may destroy the CPU card.

Settings 2

In Configuration 2, there are variables that, in case of carelessness or lack of knowledge, may affect the safety systems or operating safety of the machine. Because of this, these variables are protected by a code system. Each time a variable needs to be changed, it is necessary to obtain a new code from the manufacturer.

The following variables are available in **Configuration 2**:

HEATING RELAY ON IF NOT HEATED	ERROR, START NOT ALLOWED
TEMPERATURE INCREASE ALLOWED	ERROR, MIS COMMUNICATION
LEVEL EMPTY	ERROR, EWD INTERLOCK
LEVEL OVERFILL	ERROR, I/O COMMUNICATION
PAUSE TEST LEVEL	ERROR, LOW OIL LEVEL
PAUSE TEST TEMPERATURE	ERROR, LOW OR HIGH VOLTAGE
DEFAULT TEMPERATURE HYSTERIS	ERROR, ERROR CODES FROM MOTOR
TEMPERATURE STEP IN COOL-DOWN	ERROR, PRESS. SENSOR TILT
DEFAULT LOW EXTRACT TIME	ERROR, PRESSURE SENSOR TIMEOUT
DEFAULT MEDIUM EXTRACT TIME	ERROR, DOOR SWITCH TILT
DEFAULT HIGH EXTRACT TIME	ERROR, LEVEL OFFSET
DEFAULT DRAIN TIME	ERROR, LEVEL SYSTEM NOT CALIB.
DEFAULT DISTR. TIME	TIME DELAY BEFORE DOOR OPENING
DO UNBALANCE MEASUREMENT	UPPER TEMPERATURE FOR ERROR
DRAIN OPEN DELAY	LOWER TEMPERATURE FOR ERROR
START EXTRACT TIME	MAX ADJUST TEMPERATURE
ROLLOUT TIME	MAXIMUM EXTRACT SPEED
PAY PER WASH ALARM	DEFAULT WASH SPEED
LOCK TEST DELAY	DISTRIBUTION SPEED 1
DRAIN TIME WHEN OVERFILL	DISTRIBUTION SPEED 2
OIL LUBRICATION HOURS	DEFAULT LOW EXTRACT SPEED
PULSE TIME OIL LUBR. SEC	DEFAULT MEDIUM EXTRACT SPEED
AMOUNT OF I/O MODULES (1-3)	DEFAULT HIGH EXTRACT SPEED
DELAY CLEAR DOOR TEXT	START EXTRACT SPEED
TIMEOUT DRAIN AT PROGRAM START	DEFAULT WASH ACCELERATION
TIMEOUT DURING PAUSE	DISTRIBUTION ACCELERATION
MINIMUM TEMPERATURE INCREASE	RETARDATION ACCELERATION
DOOR OPEN DELAY FOR MOTOR LOST	EXTRACT ACCELERATION
ERROR, NO WATER	START EXTRACT ACCELERATION
ERROR, OPEN DOOR	EXTRACT RETARDATION
ERROR, DOOR LOCK	MAX SPEED DURING FILLING
ERROR, LOW TEMPERATURE	MAX LEVEL OFFS. FOR AUT. CALIB.
ERROR, HIGH TEMPERATURE	TIME AT DISTRIBUTION SPEED 2
ERROR, WATER IN MACHINE	NUMBER OF REDIST LOW 1 UNB.
ERROR, NO HEAT	NUMBER OF REDIST LOW 2 UNB.
ERROR, REMAINING WATER	NUMBER OF REDIST MEDIUM UNB.
ERROR, UNBALANCE SWITCH	NUMBER OF REDIST HIGH UNB.
ERROR, MOTOR COMMUNICATION	NUMBER OF REDIST EXTREME UNB.
ERROR, LEVEL ADJUST	DRAIN TIME AT PROGR. START
ERROR, EMERGENCY STOP	DRAIN TIME AT PROGR. END
ERROR, WEIGHT FROM SCALE	READY
ERROR, DOOR LOCK SWITCH	

To select the "SETTINGS 2" function

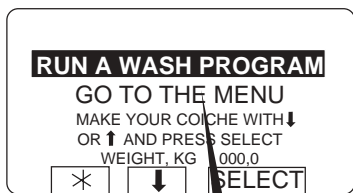

If this menu is not currently displayed:

Press repeatedly.



Press to highlight "GO TO THE MENU".



Press SELECT.

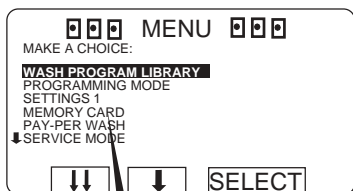

Press several times...

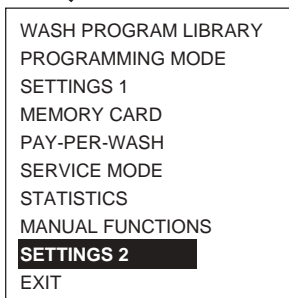

... to highlight "SETTINGS 2".



Press SELECT.

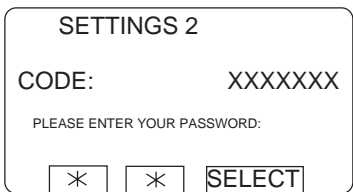

Enter the **four-digit code** supplied by the supplier.



Press SELECT.

Changes in "SETTINGS 2" must be approved by the supplier

The variables which you can change via "SETTINGS 2" belong to a category which, if they are changed carelessly or incorrectly, could jeopardise the machine's safety system(s) or its reliability.

For this reason SETTINGS 2 is protected by a code/password system. Every time you access SETTINGS 2 you have to obtain a new password from the supplier.

The system works like this:

- When you open SETTINGS 2, you will see an eight-digit code. This code will be different each time you open SETTINGS 2.
- You need to tell the supplier, Sweden exactly what this code was. Using a special computer program, they will then ascertain the four-digit password which unlocks this code, and give it to you. This password will work only with the eight-digit code you have noted this time.
- Once you have entered the password, you have access to SETTINGS 2, and can change functions as required.

Variables in Settings 2

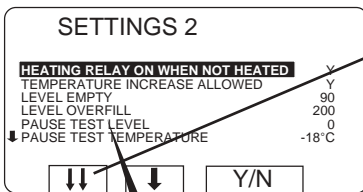

When the top line of a menu is highlighted you have the option of scrolling down through the menu faster by pressing **↓↓**. When you do, the next portion of the menu is displayed, with its last line highlighted.

HEATING RELAY ON IF NOT HEATED	Y
TEMPERATURE INCREASE ALLOWED	Y
LEVEL EMPTY	90
LEVEL OVERFILL	200
PAUSE TEST LEVEL	0
PAUSE TEST TEMPERATURE	-18 °C
DEFAULT TEMPERATURE HYSTERIS	4 °C
TEMPERATURE STEP IN COOL-DOWN	4 °C
DEFAULT LOW EXTRACT TIME	00:00
DEFAULT MEDIUM EXTRACT TIME	00:00
DEFAULT HIGH EXTRACT TIME	00:00
DEFAULT DRAIN TIME	00:00
DEFAULT DISTR. TIME	00:00
DO UNBALANCE MEASUREMENT	N
DRAIN OPEN DELAY	0:13
START EXTRACT TIME	00:30
ROLLOUT TIME	00:01
PAY PER WASH ALARM	0
LOCK TEST DELAY	0:10
DRAIN TIME WHEN OVERFILL	0:05
OIL LUBRICATION HOURS	100
PULSE TIME OIL LUBR. SEC	0:01
AMOUNT OF I/O MODULES (1-3)	1
DELAY CLEAR DOOR TEXT	04:00
TIMEOUT DRAIN AT PROGRAM START	4:00
TIMEOUT DURING PAUSE	0:00
MINIMUM TEMPERATURE INCREASE	5 °C
DOOR OPEN DELAY FOR MOTOR LOST	1:00
ERROR, NO WATER	Y
ERROR, OPEN DOOR	Y
ERROR, DOOR LOCK	Y
ERROR, LOW TEMPERATURE	Y
ERROR, HIGH TEMPERATURE	Y
ERROR, WATER IN MACHINE	Y
ERROR, NO HEAT	Y
ERROR, REMAINING WATER	Y
ERROR, UNBALANCE SWITCH	Y
ERROR, MOTOR COMMUNICATION	Y
ERROR, LEVEL ADJUST	Y
ERROR, EMERGENCY STOP	Y
ERROR, WEIGHT FROM SCALE	Y
ERROR, DOOR LOCK SWITCH	Y
ERROR, START NOT ALLOWED	Y
ERROR, MIS COMMUNICATION	Y
ERROR, EWD INTERLOCK	Y
ERROR, I/O COMMUNICATION	Y
ERROR, LOW OIL LEVEL	Y
ERROR, LOW OR HIGH VOLTAGE	Y
ERROR, ERROR CODES FROM MOTOR	Y
ERROR, PRESS. SENSOR TILT	Y
ERROR, PRESSURE SENSOR TIMEOUT	Y
ERROR, DOOR SWITCH TILT	Y
ERROR, LEVEL OFFSET	Y
ERROR, LEVEL SYSTEM NOT CALIB	Y
TIME DELAY BEFORE DOOR OPENING	0:30
UPPER TEMPERATURE FOR ERROR	98°C
LOWER TEMPERATURE FOR ERROR	-9 °C
MAX ADJUST TEMPERATURE	97 °C
MAXIMUM EXTRACT SPEED	1200
DEFAULT WASH SPEED	48
DISTRIBUTION SPEED	90
DEFAULT LOW EXTRACT RPM	550
DEFAULT MEDIUM EXTRACT RPM	700
DEFAULT HIGH EXTRACT RPM	900
START EXTRACT SPEED	1000
DEFAULT WASH ACCELERATION	20
DISTRIBUTION ACCELERATION	9
EXTRACT ACCELERATION	40
START EXTRACT ACCELERATION	40
EXTRACT RETARDATION	50
MAX SPEED DURING FILLING	100
MAX LEVEL OFFS. FOR AUT. CALIB.	
TIME AT DISTRIBUTION SPEED 2	
NUMBER OF REDIST LOW 1 UNB.	
NUMBER OF REDIST LOW 2 UNB.	
NUMBER OF REDIST MEDIUM UNB.	
NUMBER OF REDIST HIGH UNB.	
NUMBER OF REDIST EXTREME UNB.	
DRAIN TIME AT PROG. START	
DRAIN TIME AT PROG. END	
READY	

Answer the **questions** using the function key or the numeric keys.

Press **↓** to move on to the next question.

You can go back and change a question you have answered already by pressing **↑** repeatedly.

Different types of question

The questions in the various modules are of two different types, each of which needs to be answered in a different way:

Yes/No questions

The function key display shows **Y/N**, which is a toggle function (the letter to the right of the highlighted question toggles between **N** and **Y** each time it is pressed).

Times, temperatures, water levels

To answer these questions, use the numeric keys. The number of digits required will vary. If you make a mistake while entering digits, delete it by pressing **ERASE** one or more times.

No confirmation of value entered

Once you have entered the right value, you simply move on to the next by pressing **↓**. There is no enter or return key to press to confirm each value.

To alter the value for a question you have already answered

Press **↑** to highlight the question you want, then simply change the value.

Confirm changes before you exit Settings 2

If you have changed any of the variables, this change must be confirmed when you exit Settings 2. To do this you have to use a strap to short-circuit two terminals on the CPU board, see section headed "To conclude making changes in variables under SETTINGS 2".

HEATING RELAY ON IF NOT HEATED	Y
TEMPERATURE INCREASE ALLOWED	Y
LEVEL EMPTY	90
LEVEL OVERFILL	200
PAUSE TEST LEVEL	0
PAUSE TEST TEMPERATURE	-18 °C
DEFAULT TEMPERATURE HYSTERIS	4 °C
TEMPERATURE STEP IN COOL-DOWN	4 °C
DEFAULT LOW EXTRACT TIME	00:00
DEFAULT MEDIUM EXTRACT TIME	00:00
DEFAULT HIGH EXTRACT TIME	00:00
DEFAULT DRAIN TIME	00:00
DEFAULT DISTR. TIME	00:00
DO UNBALANCE MEASUREMENT	N
DRAIN OPEN DELAY	0:13
START EXTRACT TIME	00:30

Heating relay on

Here you determine whether the heating relay will switch on when heating begins.

Note that the heating relay switches on even if the answer "Yes" is in place for the function "MACHINE NOT HEATED" (see "SETTINGS 1").

If you answer **Yes (Y)**:

The heating relay will switch on when heating begins. This is the normal sequence in machines with heating.

If you answer **No (N)**:

The heating relay will not switch on. Used for machines without heating (not using heating), which are equipped with a heating relay.

Y/N Answer Yes (Y) or No (N).

Press .

HEATING RELAY ON IF NOT HEATED	Y
TEMPERATURE INCREASE ALLOWED	Y
LEVEL EMPTY	90
LEVEL OVERFILL	200
PAUSE TEST LEVEL	0
PAUSE TEST TEMPERATURE	-18 °C
DEFAULT TEMPERATURE HYSTERIS	4 °C
TEMPERATURE STEP IN COOL-DOWN	4 °C
DEFAULT LOW EXTRACT TIME	00:00
DEFAULT MEDIUM EXTRACT TIME	00:00
DEFAULT HIGH EXTRACT TIME	00:00
DEFAULT DRAIN TIME	00:00
DEFAULT DISTR. TIME	00:00
DO UNBALANCE MEASUREMENT	N
DRAIN OPEN DELAY	0:13
START EXTRACT TIME	00:30

Temperature increase allowed

Here you determine whether or not it will be possible for the user, during a wash program, to adjust the wash temperature to a level **higher than the temperature set** (this would be done by highlighting the line "SET TEMPERATURE" and entering a different wash temperature).

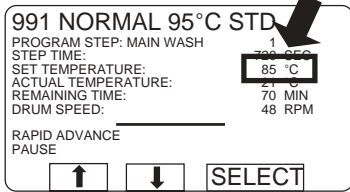

The following functions determine how temperatures may be changed:

TEMPERATURE INCREASE ALLOWED

If you answer **Yes (Y)**:

This allows the temperature to be changed to a value which is either **higher or lower** than the original "set temperature" of the wash program.

If you answer **No (N)**:

The only type of change allowed will be to a value which is **lower** than the original "set temperature".

Under "SETTINGS 1" there is the function: **ADJUST TEMPERATURE ALLOWED** which determines whether or not altering the temperature is allowed at all.

Under "SETTINGS 2" (i.e. later in this section) there is the function: **MAX ADJUST TEMPERATURE** which determines the upper temperature limit for manual temperature adjustment.

Y/N Answer Yes (Y) or No (N).

Press .

HEATING RELAY ON IF NOT HEATED	Y
TEMPERATURE INCREASE ALLOWED	Y
LEVEL EMPTY	90
LEVEL OVERFILL	200
PAUSE TEST LEVEL	0
PAUSE TEST TEMPERATURE	-18 °C
DEFAULT TEMPERATURE HYSTERIS	4 °C
TEMPERATURE STEP IN COOL-DOWN	4 °C
DEFAULT LOW EXTRACT TIME	00:00
DEFAULT MEDIUM EXTRACT TIME	00:00
DEFAULT HIGH EXTRACT TIME	00:00
DEFAULT DRAIN TIME	00:00
DEFAULT DISTR. TIME	00:00
DO UNBALANCE MEASUREMENT	N
DRAIN OPEN DELAY	0:13
START EXTRACT TIME	00:30

Level empty

Here you determine the water level at which the drum will be regarded as empty.

It is advisable to set this level so that the inner drum will have emptied, but so that some water remains in the outer drum.

If the water has not fallen to this level before the drain time has ended, the message "NOT DRAINED" will appear on the display.

For information on the levels used for the various machines, see the manual "Programming, PCS Program Control Unit".

Use the numeric keys to enter the value.



If you make a mistake while entering digits:

Press **ERASE**.



When you have finished:

Press  .

HEATING RELAY ON IF NOT HEATED	Y
TEMPERATURE INCREASE ALLOWED	Y
LEVEL EMPTY	90
LEVEL OVERFILL	200
PAUSE TEST LEVEL	0
PAUSE TEST TEMPERATURE	-18 °C
DEFAULT TEMPERATURE HYSTERIS	4 °C
TEMPERATURE STEP IN COOL-DOWN	4 °C
DEFAULT LOW EXTRACT TIME	00:00
DEFAULT MEDIUM EXTRACT TIME	00:00
DEFAULT HIGH EXTRACT TIME	00:00
DEFAULT DRAIN TIME	00:00
DEFAULT DISTR. TIME	00:00
DO UNBALANCE MEASUREMENT	N
DRAIN OPEN DELAY	0:13
START EXTRACT TIME	00:30

Level for over-filled drum

Here you determine the water level at which the drum will be regarded as over-filled.

Over-filling can occur if a water valve is faulty, or if you have over-filled the machine manually.

For information on the levels used for the various machines, see the manual "Programming, PCS Program Control Unit".

Under "SETTINGS 2" (i.e. later in this section) there are two functions which influence the way the machine reacts to over-filling:

"DRAIN TIME WHEN OVERFILL"

(i.e. DRAIN TIME AFTER OVER-FILLING)

If you have the answer N (No) inserted for the function "ERROR OVER-FILLED" (described below, this page), the drain valve will open and discharge water for the time inserted as a parameter under "DRAIN TIME WHEN OVERFILL". The level will be checked after that, and the same sequence will be repeated until the level is back to normal.

ERROR OVER-FILLED

If you answer Y (Yes): if the drum becomes over-filled, the machine will stop and the error message "MACHINE OVER-FILLED" will be displayed.

If you answer N (No): the drain valve will open as described above.

Use the numeric keys to enter the value.



If you make a mistake while entering digits:

Press **ERASE**.



When you have finished:

Press  .

HEATING RELAY ON IF NOT HEATED	Y
TEMPERATURE INCREASE ALLOWED	Y
LEVEL EMPTY	90
LEVEL OVERFILL	200
PAUSE TEST LEVEL	0
PAUSE TEST TEMPERATURE	-18 °C
DEFAULT TEMPERATURE HYSTERIS	4 °C
TEMPERATURE STEP IN COOL-DOWN	4 °C
DEFAULT LOW EXTRACT TIME	00:00
DEFAULT MEDIUM EXTRACT TIME	00:00
DEFAULT HIGH EXTRACT TIME	00:00
DEFAULT DRAIN TIME	00:00
DEFAULT DISTR. TIME	00:00
DO UNBALANCE MEASUREMENT	N
DRAIN OPEN DELAY	0:13
START EXTRACT TIME	00:30

Test values for pause

Here you determine whether, and if relevant, the conditions under which it will be allowed for the user to open the door during a wash program, for example to take samples of the water.

The following conditions must be fulfilled before it will be possible to open the door:

- The user must have pressed Pause.
- The water level must not exceed the level parameter you have programmed as PAUSE TEST LEVEL.
- The temperature must not exceed the temperature you have programmed as PAUSE TEST TEMPERATURE.

If one or both of the parameters above is set at 0, this function will be disabled and it will not be possible to open the door during the wash program.

Use the numeric keys to enter the values.



If you make a mistake while entering digits:

Press ERASE.



When you have finished:

Press [down arrow] .

HEATING RELAY ON IF NOT HEATED	Y
TEMPERATURE INCREASE ALLOWED	Y
LEVEL EMPTY	90
LEVEL OVERFILL	200
PAUSE TEST LEVEL	0
PAUSE TEST TEMPERATURE	-18 °C
DEFAULT TEMPERATURE HYSTERIS	4 °C
TEMPERATURE STEP IN COOL-DOWN	4 °C
DEFAULT LOW EXTRACT TIME	00:00
DEFAULT MEDIUM EXTRACT TIME	00:00
DEFAULT HIGH EXTRACT TIME	00:00
DEFAULT DRAIN TIME	00:00
DEFAULT DISTR. TIME	00:00
DO UNBALANCE MEASUREMENT	N
DRAIN OPEN DELAY	0:13
START EXTRACT TIME	00:30

Temperature hysteresis

Here you determine a default value for the machine's temperature hysteresis.

The temperature hysteresis can be programmed individually for each wash program. However, under certain circumstances, e.g. when the user has set the temperature manually, the PCU may not be able to find the temperature hysteresis values in the current wash program. That is when it needs to use the default value stored here.

What is temperature hysteresis?

Once the drum has filled with water to the right level, it is heated to the wash temperature you have programmed. During the wash the water will cool down somewhat.

When the water temperature has reached a lower limit, heating restarts and the water temperature is brought back up to the correct level.

Temperature hysteresis is the number of degrees between the wash temperature and the temperature at which heating needs to restart.

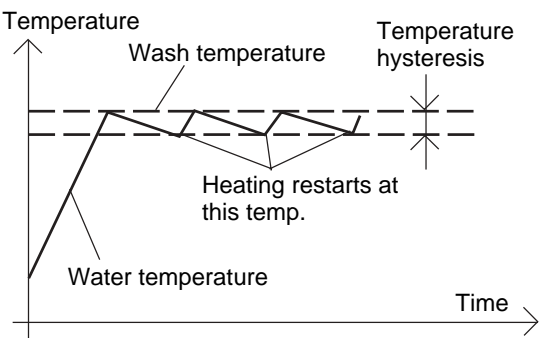

Use the numeric keys to enter the value.



If you make a mistake while entering digits:

Press ERASE.



When you have finished:

Press [down arrow] .

HEATING RELAY ON IF NOT HEATED	Y
TEMPERATURE INCREASE ALLOWED	Y
LEVEL EMPTY	90
LEVEL OVERFILL	200
PAUSE TEST LEVEL	0
PAUSE TEST TEMPERATURE	-18 °C
DEFAULT TEMPERATURE HYSTERIS	4 °C
TEMPERATURE STEP IN COOL-DOWN	4 °C
DEFAULT LOW EXTRACT TIME	00:00
DEFAULT MEDIUM EXTRACT TIME	00:00
DEFAULT HIGH EXTRACT TIME	00:00
DEFAULT DRAIN TIME	00:00
DEFAULT DISTR. TIME	00:00
DO UNBALANCE MEASUREMENT	N
DRAIN OPEN DELAY	0:13
START EXTRACT TIME	00:30

Use the numeric keys to enter the value.



If you make a mistake while entering digits:

Press ERASE.



When you have finished:

Press [Down Arrow] .

Temperature step in cool-down

Here you determine the maximum reduction in temperature per minute during the first stage of cool-down.

How does cool-down work?

When creating a new wash program you can, to prevent creasing of the load, use the COOL-DOWN module to achieve controlled cool-down of the water in the drum. The cool-down sequence is divided into two stages:

1 wash temperature to middle temperature

Throughout this stage the machine will monitor the cool-down rate, to ensure it does not exceed the limit value you are determining here. If the rate set is exceeded, no water will be added until the mean value is acceptable again.

2 middle temperature to final temperature

The rate of cool-down is not monitored during this stage. The valve opens and shuts as you have programmed it to do.

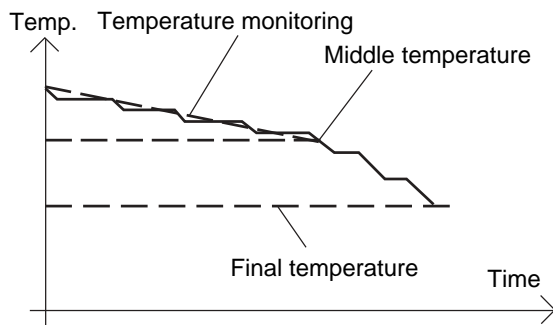

Default values, extraction time

Here you determine how long the machine will extract at the speeds low, medium and high. Later in this section you will find the instructions for programming the actual speeds to be used for low, medium, high and "turbo" extraction.

How an extraction sequence works:

In order to extract some of the water from the load at lower speeds, the drum does not accelerate to its highest speed immediately. Instead it accelerates in several steps. This means that the drum first accelerates to a low speed level, remains at that for a certain time, then accelerates to a higher level, extracts at that speed for a certain time, and so on until it reaches its final (maximum) extraction speed. If you program a low extraction speed, the number of steps at the beginning of the extraction sequence may be reduced.

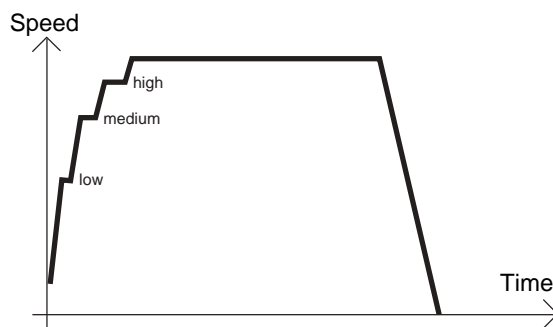

HEATING RELAY ON IF NOT HEATED	Y
TEMPERATURE INCREASE ALLOWED	Y
LEVEL EMPTY	90
LEVEL OVERFILL	200
PAUSE TEST LEVEL	0
PAUSE TEST TEMPERATURE	-18 °C
DEFAULT TEMPERATURE HYSTERIS	4 °C
TEMPERATURE STEP IN COOL-DOWN	4 °C
DEFAULT LOW EXTRACT TIME	00:00
DEFAULT MEDIUM EXTRACT TIME	00:00
DEFAULT HIGH EXTRACT TIME	00:00
DEFAULT DRAIN TIME	00:00
DEFAULT DISTR. TIME	00:00
DO UNBALANCE MEASUREMENT	N
DRAIN OPEN DELAY	0:13
START EXTRACT TIME	00:30

Applies only to machines with frequency-controlled motor.

Use the numeric keys to enter the value.



If you make a mistake while entering digits:

Press ERASE.



When you have finished:

Press [Down Arrow] .

PAUSE TEST LEVEL	0
PAUSE TEST TEMPERATURE	-18 °C
DEFAULT TEMPERATURE HYSTERIS	4 °C
TEMPERATURE STEP IN COOL-DOWN	4 °C
DEFAULT LOW EXTRACT TIME	00:00
DEFAULT MEDIUM EXTRACT TIME	00:00
DEFAULT HIGH EXTRACT TIME	00:00
DEFAULT DRAIN TIME	00:00
DEFAULT DISTR. TIME	00:00
DO UNBALANCE MEASUREMENT	N
DRAIN OPEN DELAY	0:13
START EXTRACT TIME	00:30
ROLLOUT TIME	00:01
PAY PER WASH ALARM	0

Default values for re-start after unbalance
 Here you determine the drain time and distribution time the machine will use if it cannot find the time parameters it requires, e.g. during manual operation of the drain in a washer extractor with a suspended drum.



Use the numeric keys to enter the value.

If you make a mistake while entering digits:
 Press ERASE.



When you have finished:
 Press .

DEFAULT TEMPERATURE HYSTERIS	4 °C
TEMPERATURE STEP IN COOL-DOWN	4 °C
DEFAULT LOW EXTRACT TIME	00:00
DEFAULT MEDIUM EXTRACT TIME	00:00
DEFAULT HIGH EXTRACT TIME	00:00
DEFAULT DRAIN TIME	00:00
DEFAULT DISTR. TIME	00:00
DO UNBALANCE MEASUREMENT	N
DRAIN OPEN DELAY	0:13
START EXTRACT TIME	00:30
ROLLOUT TIME	00:01
PAY PER WASH ALARM	0
LOCK TEST DELAY	0:10
DRAIN TIME WHEN OVERFILL	0:05

Unbalance measurement
 Here you determine whether the machine will calculate unbalance before it accelerates to extraction speed. Drum unbalance can only be calculated in washer extractors with suspended drums. It uses torque data from the motor control unit to determine whether the imbalance is too high.
 For washer extractors with suspended drums without frequency control and which have a separate unbalance switch, the answer to this question should be No.
 If you answer Yes (Y):
 The machine will calculate unbalance before every extraction sequence.
 If you answer No (N):
 The machine will not calculate unbalance.



Answer Yes (Y) or No (N).



Press .

TEMPERATURE STEP IN COOL-DOWN	4 °C
DEFAULT LOW EXTRACT TIME	00:10
DEFAULT MEDIUM EXTRACT TIME	00:15
DEFAULT HIGH EXTRACT TIME	00:20
DEFAULT DRAIN TIME	00:40
DEFAULT DISTR. TIME	00:30
DO UNBALANCE MEASUREMENT	Y
DRAIN OPEN DELAY	0:13
START EXTRACT TIME	00:30
ROLLOUT TIME	00:01
PAY PER WASH ALARM	0
LOCK TEST DELAY	0:10
DRAIN TIME WHEN OVERFILL	0:05
OIL LUBRICATION HOURS	100



Use the numeric keys to enter the value.

If you make a mistake while entering digits:

Press **ERASE**.



When you have finished:

Press .

DEFAULT LOW EXTRACT TIME	00:10
DEFAULT MEDIUM EXTRACT TIME	00:15
DEFAULT HIGH EXTRACT TIME	00:20
DEFAULT DRAIN TIME	00:40
DEFAULT DISTR. TIME	00:30
DO UNBALANCE MEASUREMENT	Y
DRAIN OPEN DELAY	0:13
START EXTRACT TIME	00:30
ROLLOUT TIME	00:01
PAY PER WASH ALARM	0
LOCK TEST DELAY	0:10
DRAIN TIME WHEN OVERFILL	0:05
OIL LUBRICATION HOURS	100
PULSE TIME OIL LUBR. SEC	0:01



Use the numeric keys to enter the value.

If you make a mistake while entering digits:

Press **ERASE**.



When you have finished:

Press .

Drain open delay

Here you determine whether you want a delay before the drain valve opens, for example if you want the drum to have time to gather speed first, before the valve opens.

The drain module

may be structured according to point 1 (here) only, according to point 2 only, or a combination of 1 and 2, according to the way you program.

1 Drain time

The drain will be open. The motor may be at a standstill, on gentle action or normal action.

2 Distribution time

The drain will be open. The motor runs at distribution speed. During this time the wash load will be distributed evenly around the walls of the inner drum.

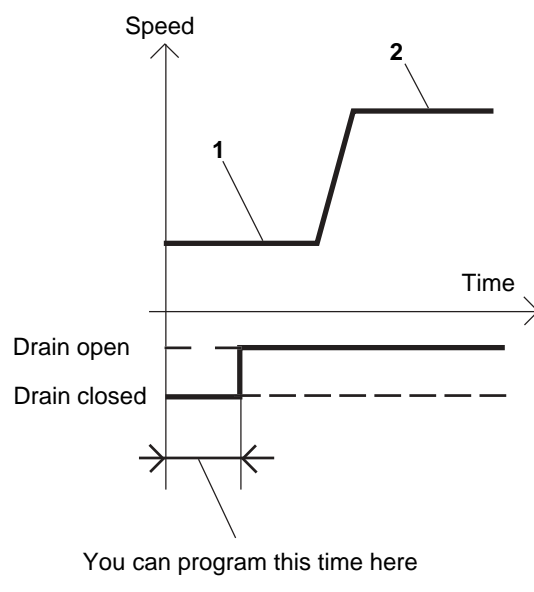

Start extract time (i.e. Initial extraction time)

Here you determine the length of time for initial extraction (if used).

When you are programming the "main data" for a wash program you can determine whether the program is to begin with initial extraction. Initial extraction is used to spin the load outwards against the drum walls, which makes it absorb water more readily on first filling. As a result of this the machine will not require so much extra filling (repeated topping up) later (to maintain its required water level).

There are two other functions affecting initial extraction which can be programmed under SETTINGS 2:

- START EXTRACT SPEED
- START EXTRACT ACCELERATION

DEFAULT MEDIUM EXTRACT TIME	00:15
DEFAULT HIGH EXTRACT TIME	00:20
DEFAULT DRAIN TIME	00:40
DEFAULT DISTR. TIME	00:30
DO UNBALANCE MEASUREMENT	Y
DRAIN OPEN DELAY	0:13
START EXTRACT TIME	00:30
ROLLOUT TIME	00:01
PAY PER WASH ALARM	0
LOCK TEST DELAY	0:10
DRAIN TIME WHEN OVERFILL	0:05
OIL LUBRICATION HOURS	100
PULSE TIME OIL LUBR. SEC	0:01
AMOUNT OF I/O MODULES (1-3)	3



Use the numeric keys to enter the value.

If you make a mistake while entering digits:

Press **ERASE**.



When you have finished:

Press .

Rollout time

Here you determine whether you want a time delay after each extraction before the machine starts to fill with water, to give the motor time to slow down.

This function is useful if the motor is not a frequency-controlled one.

Another function, intended primarily for frequency-controlled motors (which continuously report motor speed to the PCU), is called "MAX. SPEED DURING FILLING" (SETTINGS 2, described later in this section). This function allows you to specify a speed which the motor must drop below before water filling can begin.

If these functions are combined, you must ensure that the "rollout time" will have ended before water filling is allowed to begin, regardless of whether the drum speed has, prior to that, dropped below the speed specified in "MAX. SPEED DURING FILLING".

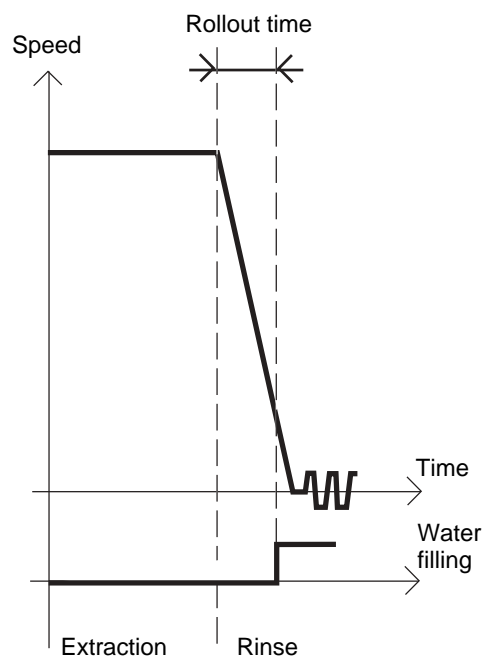

DEFAULT HIGH EXTRACT TIME	00:20
DEFAULT DRAIN TIME	00:40
DEFAULT DISTR. TIME	00:30
DO UNBALANCE MEASUREMENT	Y
DRAIN OPEN DELAY	0:13
START EXTRACT TIME	00:30
ROLLOUT TIME	00:01
PAY PER WASH ALARM	0
LOCK TEST DELAY	0:10
DRAIN TIME WHEN OVERFILL	0:05
OIL LUBRICATION HOURS	100
PULSE TIME OIL LUBR. SEC	0:01
AMOUNT OF I/O MODULES (1-3)	3

Pay per wash

This question is for special installations with pay systems. How to use it is described in the documentation supplied with these systems.



Press .

DO UNBALANCE MEASUREMENT	Y
DRAIN OPEN DELAY	0:13
START EXTRACT TIME	00:30
ROLLOUT TIME	00:01
PAY PER WASH ALARM	0
LOCK TEST DELAY	0:10
DRAIN TIME WHEN OVERFILL	0:05
OIL LUBRICATION HOURS	100
PULSE TIME OIL LUBR. SEC	0:01
AMOUNT OF I/O MODULES (1-3)	3
DELAY CLEAR DOOR TEXT	04:00
MAX DRAIN TIME	4:00

Lock test delay

Here you determine the length of time between when the door is locked and when the check should be made of the lock's microswitch.

When the machine commands that the door be locked, the door lock is activated. The lock actuates a microswitch which signals whether or not the door is really locked.

Note that the machine always begins its wash sequence immediately after the door has been locked, and that the time you program here will not affect that. If, when this check is made, the microswitch should signal that the door is not locked, the machine will stop and the error message DOOR UNLOCKED will be displayed.

Use the numeric keys to enter the value.

If you make a mistake while entering digits:

Press ERASE.



When you have finished:

Press .

DRAIN OPEN DELAY	0:13
START EXTRACT TIME	00:30
ROLLOUT TIME	00:01
PAY PER WASH ALARM	0
LOCK TEST DELAY	0:10
DRAIN TIME WHEN OVERFILL	0:05
OIL LUBRICATION HOURS	100
PULSE TIME OIL LUBR. SEC	0:01
AMOUNT OF I/O MODULES (1-3)	3
DELAY CLEAR DOOR TEXT	04:00
MAX DRAIN TIME	4:00
TIMEOUT DURING PAUSE	1:00



Use the numeric keys to enter the value.

If you make a mistake while entering digits:

Press **ERASE**.



When you have finished:

Press  .

Time drain to open after over-filling

Here you determine how long the drain valve should open for if the machine has over-filled, provided you ensure that the parameter (response) stored for the function ERROR OVER-FILLED is N (No) (see below). The drain valve will open for the time programmed and the level will then be checked. If the level is still too high, the drain valve will open again, and so on.

Over-filling can occur if a water valve is faulty, or if you have over-filled the machine manually.

Also under "SETTINGS 2" there are two functions which influence the way the machine reacts to over-filling:

ERROR OVER-FILLED

If you answer Y (Yes): if the drum becomes over-filled, the machine will stop and the error message "MACHINE OVER-FILLED" will be displayed.

If you answer N (No): the drain valve will open as described above.

LEVEL OVERFILL (i.e. DRUM OVER-FILLED)

Here you specify the level at which the drum is considered to be "over-filled".

PAY PER WASH ALARM	0
LOCK TEST DELAY	0:10
DRAIN TIME WHEN OVERFILL	0:05
OIL LUBRICATION HOURS	100
PULSE TIME OIL LUBR. SEC	0:01
AMOUNT OF I/O MODULES (1-3)	3
DELAY CLEAR DOOR TEXT	04:00
MAX DRAIN TIME	4:00
TIMEOUT DURING PAUSE	1:00
MINIMUM TEMPERATURE INCREASE	5°C
DOOR OPEN DELAY FOR MOTOR LOST	1:00
ERROR, NO WATER	Y

Oil lubrication
Here you determine the lubrication interval and pulse time for the oil lubrication systems used on larger washer extractors.



Use the numeric keys to enter the value.

If you make a mistake while entering digits:

Press **ERASE**.



When you have finished:

Press .

PAY PER WASH ALARM	0
LOCK TEST DELAY	0:10
DRAIN TIME WHEN OVERFILL	0:05
OIL LUBRICATION HOURS	100
PULSE TIME OIL LUBR. SEC	0:01
AMOUNT OF I/O MODULES (1-3)	3
DELAY CLEAR DOOR TEXT	04:00
MAX DRAIN TIME	4:00
TIMEOUT DURING PAUSE	1:00
MINIMUM TEMPERATURE INCREASE	5°C
DOOR OPEN DELAY FOR MOTOR LOST	1:00
ERROR, NO WATER	Y

Number of I/O circuit boards
Here you specify how many I/O circuit boards the PCU has.
Different types of washer extractor may be equipped with one, two or three I/O boards, according to how many inputs and outputs the particular machine needs (e.g. for external liquid supply, tilt function and extra water valves).



Use the numeric keys to enter the value.

If you make a mistake while entering digits:

Press **ERASE**.



When you have finished:

Press .

DRAIN TIME WHEN OVERFILL	0:05
OIL LUBRICATION HOURS	100
PULSE TIME OIL LUBR. SEC	0:01
AMOUNT OF I/O MODULES (1-3)	3
DELAY CLEAR DOOR TEXT	04:00
MAX DRAIN TIME	4:00
TIMEOUT DURING PAUSE	1:00
MINIMUM TEMPERATURE INCREASE	5°C
DOOR OPEN DELAY FOR MOTOR LOST	1:00
ERROR, NO WATER	Y
ERROR, OPEN DOOR	Y
ERROR, DOOR LOCK	Y
ERROR, LOW TEMPERATURE	Y
ERROR, HIGH TEMPERATURE	Y

Delay clear door text

Here you determine how long the text "WAITING FOR DOOR TO UNLOCK" will remain visible if, for some reason, the door is not unlocked at the right time.

When a wash program has ended, the text above will be displayed until the door is unlocked. The door is normally unlocked within one minute on most machines.

If the door is not unlocked within a reasonable time, the most common cause is probably jamming in the lock mechanism. In these cases, the text above may mislead the user, causing him to think that the normal unlocking sequence is not yet finished.



Use the numeric keys to enter the value.

If you make a mistake while entering digits:

Press **ERASE**.



When you have finished:

Press .

OIL LUBRICATION HOURS	100
PULSE TIME OIL LUBR. SEC	0:01
AMOUNT OF I/O MODULES (1-3)	3
DELAY CLEAR DOOR TEXT	04:00
TIMEOUT DRAIN AT PROGRAM START	4:00
TIMEOUT DURING PAUSE	1:00
MINIMUM TEMPERATURE INCREASE	5°C
DOOR OPEN DELAY FOR MOTOR LOST	1:00
ERROR, NO WATER	Y
ERROR, OPEN DOOR	Y
ERROR, DOOR LOCK	Y
ERROR, LOW TEMPERATURE	Y
ERROR, HIGH TEMPERATURE	Y
ERROR, WATER IN MACHINE	Y

Timeout drain at program start

If water in machine at wash program start, and level not lower than empty level within given value, an error will be indicated.



Use the numeric keys to enter the value.

If you make a mistake while entering digits:

Press **ERASE**.



When you have finished:

Press .

OIL LUBRICATION HOURS	100
PULSE TIME OIL LUBR. SEC	0:01
AMOUNT OF I/O MODULES (1-3)	3
DELAY CLEAR DOOR TEXT	04:00
MAX DRAIN TIME	4:00
TIMEOUT DURING PAUSE	1:00
MINIMUM TEMPERATURE INCREASE	5°C
DOOR OPEN DELAY FOR MOTOR LOST	1:00
ERROR, NO WATER	Y
ERROR, OPEN DOOR	Y
ERROR, DOOR LOCK	Y
ERROR, LOW TEMPERATURE	Y
ERROR, HIGH TEMPERATURE	Y
ERROR, WATER IN MACHINE	Y



Use the numeric keys to enter the value.

If you make a mistake while entering digits:

Press **ERASE**.



When you have finished:

Press .

PULSE TIME OIL LUBR. SEC	0:01
AMOUNT OF I/O MODULES (1-3)	3
DELAY CLEAR DOOR TEXT	04:00
MAX DRAIN TIME	4:00
TIMEOUT DURING PAUSE	1:00
MINIMUM TEMPERATURE INCREASE	5°C
DOOR OPEN DELAY FOR MOTOR LOST	1:00
ERROR, NO WATER	Y
ERROR, OPEN DOOR	Y
ERROR, DOOR LOCK	Y
ERROR, LOW TEMPERATURE	Y
ERROR, HIGH TEMPERATURE	Y
ERROR, WATER IN MACHINE	Y



Use the numeric keys to enter the value.

If you make a mistake while entering digits:

Press **ERASE**.



When you have finished:

Press .

Timeout during pause

Here you determine the maximum time for a pause in the program, if it is to be available for use in calculating the average length of the program.

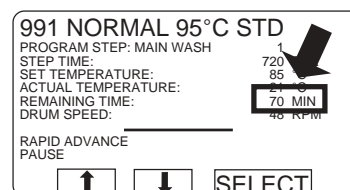

The time shown on the display alongside "REMAINING TIME" is based on the average of the last five times this program was used. This time also includes pauses in the program. If the pause time in the program exceeds the time parameter you have programmed, it will not be used for average-time calculation derived from the current program operation.

Minimum temperature increase

Here you determine the smallest temperature increase allowed during the time specified in MAXIMUM HEATING TIME (see below).

These three functions are linked:

The following two functions also affect the way in which the machine is controlled during heating:

MAXIMUM HEATING TIME (SETTINGS 1)

Here you determine the maximum time it may take to heat the water the number of degrees you have specified above.

The function ERROR, NO HEAT (SETTINGS 2)

If you answer **Y (Yes)**:

If the temperature has not increased by the number of degrees you program here over the time which is specified in MAXIMUM HEATING TIME, the error message NO HEATING will appear on the display.

If you answer **N (No)**:

Monitoring of heating will be switched off, and no error message will be displayed.

AMOUNT OF I/O MODULES (1-3)	3
DELAY CLEAR DOOR TEXT	04:00
MAX DRAIN TIME	4:00
TIMEOUT DURING PAUSE	1:00
MINIMUM TEMPERATURE INCREASE	5°C
DOOR OPEN DELAY FOR MOTOR LOST	1:00
ERROR, NO WATER	Y
ERROR, OPEN DOOR	Y
ERROR, DOOR LOCK	Y
ERROR, LOW TEMPERATURE	Y
ERROR, HIGH TEMPERATURE	Y
ERROR, WATER IN MACHINE	Y
ERROR, NO HEAT	Y

Door open delay for "motor lost"

Here you determine the length of time during which the door will be prevented from opening if, (in machines with frequency control) the MCU loses control of braking at the end of extraction.

In machines with frequency-controlled motors it is the MCU which ensures that the motor and drum are braked smoothly after extraction speed.

If anything should go wrong at this stage so that the MCU loses control of the braking process (colloquially referred to as "motor lost") the MCU will inform the PCU. If the program has reached the final extraction sequence, the PCU will ensure that the door cannot be opened until the time you program here has elapsed.

Use the numeric keys to enter the value.

If you make a mistake while entering digits:

Press **ERASE**.

When you have finished:



Press .

ERROR, NO WATER	Y
ERROR, OPEN DOOR	Y
ERROR, DOOR LOCK	Y
ERROR, LOW TEMPERATURE	Y
ERROR, HIGH TEMPERATURE	Y
ERROR, WATER IN MACHINE	Y
ERROR, NO HEAT	Y
ERROR, REMAINING WATER	Y
ERROR, UNBALANCE SWITCH	Y
ERROR, MOTOR COMMUNICATION	Y
ERROR, LEVEL ADJUST	Y
ERROR, EMERGENCY STOP	Y
ERROR, WEIGHT FROM SCALE	Y
ERROR, DOOR LOCK SWITCH	Y
ERROR, START NOT ALLOWED	Y
ERROR, MIS COMMUNICATION	Y
ERROR, EWD INTERLOCK	Y
ERROR, I/O COMMUNICATION	Y
ERROR, LOW OIL LEVEL	Y
ERROR, LOW OR HIGH VOLTAGE	Y
ERROR, ERROR CODES FROM MOTOR	Y
ERROR, PRESS SENSOR TILT	Y
ERROR, PRESSURE SENSOR TIMEOUT	Y
ERROR, DOOR SWITCH TILT	Y
ERROR, LEVEL OFFSET	Y
ERROR, LEVEL SYSTEM NOT CALIB.	Y

Switch on/off monitoring of machine functions/error message display

All of these options (involving monitoring of machine functions and display of the related error message if flagged) can be switched on or off here.

If you answer **Yes (Y)**:

This enables function monitoring/error message display for this particular line.

If you answer **No (N)**:

This disables function monitoring/error message display for this particular line.

On the next two pages is a summary of all the options accessible here, the errors monitored and the error message which will be displayed for each.

Use the numeric keys to enter the value.

If you make a mistake while entering digits:

Press **ERASE**.

When you have finished:



Press .

List of errors, functions monitored and relevant error messages displayed

Error/Function	Error message displayed
<p>01 ERROR. NO WATER Water level has not reached set level within time set. After this error message appears and the machine is reset, the machine will try again.</p>	NO WATER
<p>02 ERROR. OPEN DOOR Signal from microswitch which checks door status absent during program. After this error message appears and the machine is reset, the machine will try again.</p>	DOOR OPEN
<p>03 ERROR. DOOR LOCK Signal from microswitch which detects when the door is locked absent during program.</p>	DOOR UNLOCKED
<p>04 ERROR. LOW TEMPERATURE The temperature is below the lowest value allowed (open circuit in temperature sensor).</p>	NTC LOW TEMP
<p>05 ERROR. HIGH TEMPERATURE The temperature is above the highest value allowed (short-circuit in temperature sensor).</p>	NTC HIGH TEMP
<p>06 ERROR. WATER IN MACHINE The water level is higher than the level EMPTY at the start of the program.</p>	WATER IN DRUM
<p>07 ERROR. OVER-FILLED The water level is higher than the "LEVEL OVERFILL" (i.e. DRUM OVER-FILLED) level. If this function is switched off (=N), instead the drain valve will open for a short time and discharge some of the water. This is described under the function "DRAIN TIME WHEN OVERFILL" (i.e. DRAIN TIME AFTER OVER-FILLING) earlier in this section.</p>	MACHINE OVER-FILLED
<p>08 ERROR. NO HEAT The temperature has not increased by the number of degrees specified in the function "MIN. TEMPERATURE INCREASE" (see back in this section), over the period of time specified in the function MAXIMUM HEATING TIME (see "SETTINGS 1").</p>	NO HEATING
<p>10 ERROR. REMAINING WATER When the drain sequence has finished, the water level is still higher than the EMPTY level.</p>	NOT DRAINED
<p>11 ERROR. UNBALANCE SWITCH The unbalance switch is closed when the machine is starting on a drain sequence.</p>	UNBALANCE SENSOR FAULT
<p>13 ERROR. MOTOR COMMUNICATION Communication between PCU and motor control unit interrupted or disturbed.</p>	NO MOTOR COMM
<p>14 ERROR. LEVEL ADJUST Every machine has individual level calibration at the factory. If these calibration values are missing or fall outside the limit values, an error warning will be flagged at each program start-up. The program can still be started, however, by pressing START. It will then use standard (default) values, which means that the levels will not be as precise as intended.</p>	LEVEL CALIBRATION

List of errors, functions monitored and relevant error messages displayed, cont.

Error/Function	Error message displayed
15 ERROR. EMERGENCY STOP The emergency stop button has been pressed.	EMERGENCY STOP
16 ERROR. WEIGHT FROM SCALE Over-/Under-load of scale or weight above limit for maximum allowed weight at wash module start.	WEIGHT FROM SCALE
17 ERROR. DOOR LOCK SWITCH Even though the door lock microswitch indicates that the door is locked, the signal from the microswitch which is used to detect when the door is closed is absent.	DOOR LOCK
18 ERROR. START NOT ALLOWED Network does not allow programme start.	START NOT ALLOWED
19 ERROR. MIS COMMUNICATION Machine has lost contact with network.	MIS COMMUNICATION
20 ERROR. EWD INTERLOCK The motor control system for frequency-controlled motors (EWD) receives a signal direct from the door lock which indicates that the door really is closed. If this signal is lost, a fault signal is sent to the PCU	INTERLOCK STATUS
21 ERROR. I/O COMMUNICATION Communication between the CPU board and one of the I/O boards interrupted or disturbed.	I/O COMMUNICATION
22 ERROR. LOW OIL LEVEL In machines with an oil lubrication system, indicates low level in the oil container.	LOW OIL LEVEL
23 ERROR. LOW OR HIGH VOLTAGE Incorrect input voltage to external equipment.	PHASE
24 ERROR. PRESSURE SENSORS, TILT Both pressure sensors are active at the same time.	PRESSURE SENSOR TILT
25 ERROR. PRESSURE SENSOR TIMEOUT No pressure at the relevant pressure sensor within the maximum time allowed for tilt backwards or forwards.	PRESSURE SENSOR TIMEOUT
26 ERROR. DOOR SWITCH, TILT Door closed (S3) is "on" at a time when the machine door is locked open (S25).	DOOR SWITCH, TILT
27 ERROR. LEVEL OFFSET The pressure sensor for the water level signals a value that is so different from the empty machine state that the automatic level calibration cannot adjust the level system.	AUT. LEVEL CALIB.
28 ERROR. LEVEL NOT CALIBRATED Calibration of level system not done in service mode before use of machine.	

List of errors, functions monitored and relevant error messages displayed, cont.

Error/Function	Error message displayed
ERROR. ERROR CODES FROM MOTOR	
This function includes a number of error warnings from the motor control system for frequency-controlled motors (EWD)	
31 Temperature of MCU control circuits too high	HEAT SINK TOO HOT
32 Motor thermal protection has tripped	MOTOR TOO HOT
33 The motor has received a start command from the PCU without receiving an interlock signal from the door lock. The MCU receiving circuitry for the interlock signal is not faulty	NO INTERLOCK
35 Short-circuit between motor windings or to earth.	MOTOR SHORTNING
36 Fault in MCU receiving circuitry for lock acknowledgement signal.	INTERLOCK HARDWARE
37 DC voltage too low	LOW DC VOLTAGE
38 DC voltage too high	HIGH DC VOLTAGE
39 DC level varying too much	RIPPEL ON DC BUS
40 One phase missing for/at motor control unit	LINE INTERRUPT
41 Hardware fault, temperature monitoring, motor	KLIXON CIRCUITS

ERROR, EWD INTERLOCK	Y
ERROR, I/O COMMUNICATION	Y
ERROR, LOW OIL LEVEL	Y
ERROR, LOW OR HIGH VOLTAGE	Y
ERROR, ERROR CODES FROM MOTOR	Y
ERROR, PRESS SENSOR TILT	Y
ERROR, PRESSURE SENSOR TIMEOUT	Y
ERROR, DOOR SWITCH TILT	Y
ERROR, LEVEL OFFSET	Y
ERROR, LEVEL SYSTEM NOT CALIB.	Y
TIME DELAY BEFORE DOOR OPENING	0:30
UPPER TEMPERATURE FOR ERROR	98°C
LOWER TEMPERATURE FOR ERROR	-9°C
MAX ADJUST TEMPERATURE	97°C
MAXIMUM EXTRACT SPEED	825
DEFAULT WASH SPEED	37

Time delay before door opening

Here you determine the length of time during which the door will be prevented from opening if the machine has detected a fault-error and is displaying an error message. This must give enough time for the water to empty and drum speed to be reduced.

Please note that the water will not be emptied as a result of all types of error. In the case of the HIGH TEMPERATURE error, for example, the door will remain locked even though the time you have programmed has elapsed. One reason for this is to prevent the risk of a fire if the electrical heating equipment is still switched on and heating.



Use the numeric keys to enter the value.

If you make a mistake while entering digits:

Press **ERASE**.



When you have finished:

Press .

ERROR, I/O COMMUNICATION	Y
ERROR, LOW OIL LEVEL	Y
ERROR, LOW OR HIGH VOLTAGE	Y
ERROR, ERROR CODES FROM MOTOR	Y
ERROR, PRESS SENSOR TILT	Y
ERROR, PRESSURE SENSOR TIMEOUT	Y
ERROR, DOOR SWITCH TILT	Y
ERROR, LEVEL OFFSET	Y
ERROR, LEVEL SYSTEM NOT CALIB.	Y
TIME DELAY BEFORE DOOR OPENING	0:30
UPPER TEMPERATURE FOR ERROR	98°C
LOWER TEMPERATURE FOR ERROR	-9°C
MAX ADJUST TEMPERATURE	97°C
MAXIMUM EXTRACT SPEED	825
DEFAULT WASH SPEED	37
DISTRIBUTION SPEED	63

Upper and lower temperature limits for errors

Here you determine the temperature limits for the errors HIGH TEMPERATURE and LOW TEMPERATURE respectively.

If the HIGH TEMPERATURE error is flagged, this usually indicates an short circuit in the sensor or wiring. LOW TEMPERATURE usually indicates a open circuit in sensor or wiring. That is why the default value for the low temperature limit is -9 C. If the sensor cools to this temperature, the resistance from the sensor will be 0 ohms, which corresponds to a short-circuit.



Use the numeric keys to enter the value.

If you make a mistake while entering digits:

Press **ERASE**.



When you have finished:

Press .

ERROR, I/O COMMUNICATION	Y
ERROR, LOW OIL LEVEL	Y
ERROR, LOW OR HIGH VOLTAGE	Y
ERROR, ERROR CODES FROM MOTOR	Y
ERROR, PRESS SENSOR TILT	Y
ERROR, PRESSURE SENSOR TIMEOUT	Y
ERROR, DOOR SWITCH TILT	Y
ERROR, LEVEL OFFSET	Y
ERROR, LEVEL SYSTEM NOT CALIB.	Y
TIME DELAY BEFORE DOOR OPENING	0:30
UPPER TEMPERATURE FOR ERROR	98°C
LOWER TEMPERATURE FOR ERROR	-9°C
MAX ADJUST TEMPERATURE	97°C
MAXIMUM EXTRACT SPEED	1200
DEFAULT WASH SPEED	48
DISTRIBUTION SPEED	90

Upper limit for manual temperature adjustment ("Max adjust temperature")

Here you determine the highest temperature the user may alter the wash temperature to manually (by using to move to the line for "SET TEMPERATURE" then entering a new wash temperature).

The function above will be available only if the answer Y (Yes) is in place for these two functions:

- ADJUST TEMPERATURE (SETTINGS 1) which determines whether or not it will be allowed to alter the temperature during a program.
- TEMPERATURE INCREASE ALLOWED (SETTINGS 2) which determines whether or not it will be allowed to alter the temperature parameter to higher than the original temperature in the wash program or not.



Use the numeric keys to enter the value.

If you make a mistake while entering digits:

Press **ERASE**.



When you have finished:

Press .

ERROR, I/O COMMUNICATION	Y
ERROR, LOW OIL LEVEL	Y
ERROR, LOW OR HIGH VOLTAGE	Y
ERROR, ERROR CODES FROM MOTOR	Y
ERROR, PRESS SENSOR TILT	Y
ERROR, PRESSURE SENSOR TIMEOUT	Y
ERROR, DOOR SWITCH TILT	Y
ERROR, LEVEL OFFSET	Y
ERROR, LEVEL SYSTEM NOT CALIB.	Y
TIME DELAY BEFORE DOOR OPENING	0:30
UPPER TEMPERATURE FOR ERROR	98°C
LOWER TEMPERATURE FOR ERROR	-9°C
MAX ADJUST TEMPERATURE	97°C
MAXIMUM EXTRACT SPEED	1200
DEFAULT WASH SPEED	48
DISTRIBUTION SPEED	90

Maximum extract speed

Here you determine the machine's maximum extraction speed.

This speed cannot be exceeded, neither by programming parameters in wash programs nor by manual adjustment.



Use the numeric keys to enter the value.

If you make a mistake while entering digits:

Press **ERASE**.



When you have finished:

Press .

ERROR, PRESS SENSOR TILT	Y
ERROR, PRESSURE SENSOR TIMEOUT	Y
ERROR, DOOR SWITCH TILT	Y
ERROR, LEVEL OFFSET	Y
ERROR, LEVEL SYSTEM NOT CALIB.	Y
TIME DELAY BEFORE DOOR OPENING	0:30
UPPER TEMPERATURE FOR ERROR	98°C
LOWER TEMPERATURE FOR ERROR	-9°C
MAX ADJUST TEMPERATURE	97°C
MAXIMUM EXTRACT SPEED	825
DEFAULT WASH SPEED	48
DISTRIBUTION SPEED	90
DEFAULT LOW EXTRACT RPM	550
DEFAULT MEDIUM EXTRACT RPM	700
DEFAULT HIGH EXTRACT RPM	900
START EXTRACT SPEED	1000
DEFAULT WASH ACCELERATION	20

Default wash speed

Here you determine the wash speed the machine will use at any time when it cannot find instructions for the correct wash speed, e.g. in the event of manual operation.



Use the numeric keys to enter the value.

If you make a mistake while entering digits:

Press **ERASE**.



When you have finished:

Press  .

ERROR, PRESS. SENSOR TILT	Y
ERROR, PRESSURE SENSOR TIMEOUT	Y
ERROR, DOOR SWITCH TILT	Y
ERROR, LEVEL OFFSET	Y
ERROR, LEVEL SYSTEM NOT CALIB.	Y
TIME DELAY BEFORE DOOR OPENING	0:30
UPPER TEMPERATURE FOR ERROR	98°C
LOWER TEMPERATURE FOR ERROR	-9°C
MAX ADJUST TEMPERATURE	97°C
MAXIMUM EXTRACT SPEED	825
DEFAULT WASH SPEED	48
DISTRIBUTION SPEED 1	90
DISTRIBUTION SPEED 2	
DEFAULT LOW EXTRACT RPM	550
DEFAULT MEDIUM EXTRACT RPM	700
DEFAULT HIGH EXTRACT RPM	900
START EXTRACT SPEED	1000
DEFAULT WASH ACCELERATION	20

Distribution speed

Here you determine the machine's distribution speed. The distribution speed is not programmable when you create a wash program. Instead the machine always uses the value you set here.



Use the numeric keys to enter the value.

If you make a mistake while entering digits:

Press **ERASE**.



When you have finished:

Press  .

TIME DELAY BEFORE DOOR OPENING	0:30
UPPER TEMPERATURE FOR ERROR	98°C
LOWER TEMPERATURE FOR ERROR	-9°C
MAX ADJUST TEMPERATURE	97°C
MAXIMUM EXTRACT SPEED	1200
DEFAULT WASH SPEED	48
DISTRIBUTION SPEED	90
DEFAULT LOW EXTRACT RPM	550
DEFAULT MEDIUM EXTRACT RPM	700
DEFAULT HIGH EXTRACT RPM	900
START EXTRACT SPEED	1000
DEFAULT WASH ACCELERATION	20
DISTRIBUTION ACCELERATION	9
RETARDATION ACCELERATION	
EXTRACT ACCELERATION	40
START EXTRACT ACCELERATION	40
EXTRACT RETARDATION	50



Use the numeric keys to enter the value.

If you make a mistake while entering digits:

Press ERASE.



When you have finished:

Press .

Default value, extraction time

Here you determine the various speeds (low, medium and high) for extraction. The instructions for determining the length of extraction times are to be found earlier in SETTINGS 2.

How an extraction sequence works:

In order to extract some of the water from the load at lower speeds, the drum does not accelerate to its highest speed immediately. Instead it accelerates in several steps. This means that the drum first accelerates to a low speed level, remains at that for a certain time, then accelerates to a higher level, extracts at that speed for a certain time, and so on until it reaches its final (maximum) extraction speed. If you program a low extraction speed, the number of steps at the beginning of the extraction sequence may be reduced.

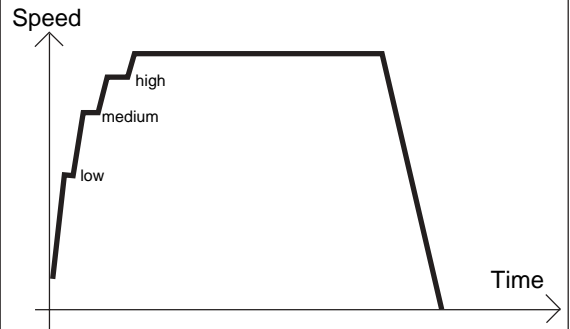

START EXTRACT SPEED	1000
DEFAULT WASH ACCELERATION	20
DISTRIBUTION ACCELERATION	9
RETARDATION ACCELERATION	
EXTRACT ACCELERATION	40
START EXTRACT ACCELERATION	40
EXTRACT RETARDATION	50
MAX SPEED DURING FILLING	100
MAX LEVEL OFFS FOR AUT. CALIB.	
TIME AT DISTRIBUTION SPEED 2	
NUMBER OF REDIST LOW 1 UNB.	
NUMBER OF REDIST LOW 2 UNB.	
NUMBER OF REDIST MEDIUM UNB.	
NUMBER OF REDIST HIGH UNB.	
NUMBER OF REDIST EXTREME UNB.	
DRAIN TIME AT PROGR. START	
DRAIN TIME AT PROGR. END	
READY	



Use the numeric keys to enter the value.

If you make a mistake while entering digits:

Press ERASE.



When you have finished:

Press .

Start extract speed (i.e. Initial extraction speed)

Here you determine the speed of initial extraction. When you are creating a wash program you can determine (under "Main data") whether it is to begin with initial extraction. Initial extraction is used to spin the load outwards against the drum walls, which makes it absorb water more readily on first filling. As a result of this the machine will not require so much extra filling later.

There are two other functions affecting initial extraction which can be programmed under SETTINGS 2:

- START EXTRACT TIME
- START EXTRACT ACCELERATION

START EXTRACT SPEED	1000
DEFAULT WASH ACCELERATION	20
DISTRIBUTION ACCELERATION	9
RETARDATION ACCELERATION	
EXTRACT ACCELERATION	40
START EXTRACT ACCELERATION	40
EXTRACT RETARDATION	50
MAX SPEED DURING FILLING	100
MAX LEVEL OFFS FOR AUT. CALIB.	
TIME AT DISTRIBUTION SPEED 2	
NUMBER OF REDIST LOW 1 UNB.	
NUMBER OF REDIST LOW 2 UNB.	
NUMBER OF REDIST MEDIUM UNB.	
NUMBER OF REDIST HIGH UNB.	
NUMBER OF REDIST EXTREME UNB.	
DRAIN TIME AT PROGR. START	
DRAIN TIME AT PROGR. END	
READY	

Default wash acceleration

Here you determine the acceleration rate (rpm/second) which the machine can use to reach wash speed when it cannot find this value elsewhere, e.g. in the event of manual operation of the drain sequence in machines with suspended drum.

1 2 3 Use the numeric keys to enter the value.

4 5 6

7 8 9 If you make a mistake while entering digits:

0

Press **ERASE**.



When you have finished:

Press .

START EXTRACT SPEED	1000
DEFAULT WASH ACCELERATION	20
DISTRIBUTION ACCELERATION	9
RETARDATION ACCELERATION	
EXTRACT ACCELERATION	40
START EXTRACT ACCELERATION	40
EXTRACT RETARDATION	50
MAX SPEED DURING FILLING	100
MAX LEVEL OFFS FOR AUT. CALIB.	
TIME AT DISTRIBUTION SPEED 2	
NUMBER OF REDIST LOW 1 UNB.	
NUMBER OF REDIST LOW 2 UNB.	
NUMBER OF REDIST MEDIUM UNB.	
NUMBER OF REDIST HIGH UNB.	
NUMBER OF REDIST EXTREME UNB.	
DRAIN TIME AT PROGR. START	
DRAIN TIME AT PROGR. END	
READY	

Distribution acceleration

Here you determine the acceleration rate (rpm/second) the machine will use to reach distribution speed and to decelerate after distribution speed, respectively. This value is not programmable when you create a wash program. Instead the machine always uses the value you set here.

1 2 3 Use the numeric keys to enter the value.

4 5 6

7 8 9 If you make a mistake while entering digits:

0

Press **ERASE**.



When you have finished:

Press .

START EXTRACT SPEED	1000
DEFAULT WASH ACCELERATION	20
DISTRIBUTION ACCELERATION	9
RETARDATION ACCELERATION	
EXTRACT ACCELERATION	40
START EXTRACT ACCELERATION	40
EXTRACT RETARDATION	50
MAX SPEED DURING FILLING	100
MAX LEVEL OFFS FOR AUT. CALIB.	
TIME AT DISTRIBUTION SPEED 2	
NUMBER OF REDIST LOW 1 UNB.	
NUMBER OF REDIST LOW 2 UNB.	
NUMBER OF REDIST MEDIUM UNB.	
NUMBER OF REDIST HIGH UNB.	
NUMBER OF REDIST EXTREME UNB.	
DRAIN TIME AT PROGR. START	
DRAIN TIME AT PROGR. END	
READY	

Extraction acceleration
 Here you determine the acceleration rate (rpm/second) the machine will use to reach extraction speed. This value is not programmable when you create a wash program. Instead the machine always uses the value you set here.

1 2 3 Use the numeric keys to enter the value.
4 5 6
7 8 9 If you make a mistake while entering digits:
0 Press ERASE.

↓ When you have finished:
 Press ↓ .

START EXTRACT SPEED	1000
DEFAULT WASH ACCELERATION	20
DISTRIBUTION ACCELERATION	9
RETARDATION ACCELERATION	
EXTRACT ACCELERATION	40
START EXTRACT ACCELERATION	40
EXTRACT RETARDATION	50
MAX SPEED DURING FILLING	100
MAX LEVEL OFFS FOR AUT. CALIB.	
TIME AT DISTRIBUTION SPEED 2	
NUMBER OF REDIST LOW 1 UNB.	
NUMBER OF REDIST LOW 2 UNB.	
NUMBER OF REDIST MEDIUM UNB.	
NUMBER OF REDIST HIGH UNB.	
NUMBER OF REDIST EXTREME UNB.	
DRAIN TIME AT PROGR. START	
DRAIN TIME AT PROGR. END	
READY	

Start extract acceleration (i.e. Acceleration rate for initial extraction)
 Here you determine the acceleration rate (rpm/second) which the machine will use to reach its initial extraction speed. This value is not programmable when you create a wash program. Instead the machine always uses the value you set here.
 There are two other functions affecting initial extraction which can be programmed under SETTINGS 2:

- START EXTRACT TIME
- START EXTRACT SPEED

1 2 3 Use the numeric keys to enter the value.
4 5 6
7 8 9 If you make a mistake while entering digits:
0 Press ERASE.

↓ When you have finished:
 Press ↓ .

START EXTRACT SPEED	1000
DEFAULT WASH ACCELERATION	20
DISTRIBUTION ACCELERATION	9
RETARDATION ACCELERATION	
EXTRACT ACCELERATION	40
START EXTRACT ACCELERATION	40
EXTRACT RETARDATION	50
MAX SPEED DURING FILLING	100
MAX LEVEL OFFS FOR AUT. CALIB.	
TIME AT DISTRIBUTION SPEED 2	
NUMBER OF REDIST LOW 1 UNB.	
NUMBER OF REDIST LOW 2 UNB.	
NUMBER OF REDIST MEDIUM UNB.	
NUMBER OF REDIST HIGH UNB.	
NUMBER OF REDIST EXTREME UNB.	
DRAIN TIME AT PROGR. START	
DRAIN TIME AT PROGR. END	
READY	

Extract retardation (i.e. Deceleration rate after extraction)

Here you determine the deceleration rate (rpm/second) at which the drum will slow down after extraction speed. This value is not programmable when you create a wash program. Instead the machine always uses the value you set here.



Use the numeric keys to enter the value.

If you make a mistake while entering digits:

Press **ERASE**.



When you have finished:

Press .

Max. speed during filling

Here you specify a speed which the motor must drop below when it is being braked after extraction. Water filling will not take place until the motor has slowed to this speed. This function is useful for frequency-controlled motors.

Another function, intended primarily for motors without frequency control, is called "ROLLOUT TIME" (accessed via SETTINGS 2, described earlier in this section). ROLLOUT TIME allows you to specify a time period which must elapse before water filling starts.

If these functions are combined, you must ensure that the "rollout time" will have ended before water filling is allowed to begin, regardless of whether the drum speed has, prior to that, dropped below the speed specified in "MAX. SPEED DURING FILLING".

START EXTRACT SPEED	1000
DEFAULT WASH ACCELERATION	20
DISTRIBUTION ACCELERATION	9
RETARDATION ACCELERATION	
EXTRACT ACCELERATION	40
START EXTRACT ACCELERATION	40
EXTRACT RETARDATION	50
MAX SPEED DURING FILLING	100
MAX LEVEL OFFS FOR AUT. CALIB.	
TIME AT DISTRIBUTION SPEED 2	
NUMBER OF REDIST LOW 1 UNB.	
NUMBER OF REDIST LOW 2 UNB.	
NUMBER OF REDIST MEDIUM UNB.	
NUMBER OF REDIST HIGH UNB.	
NUMBER OF REDIST EXTREME UNB.	
DRAIN TIME AT PROGR. START	
DRAIN TIME AT PROGR. END	
READY	



Use the numeric keys to enter the value.

If you make a mistake while entering digits:

Press **ERASE**.



When you have finished:

Press .

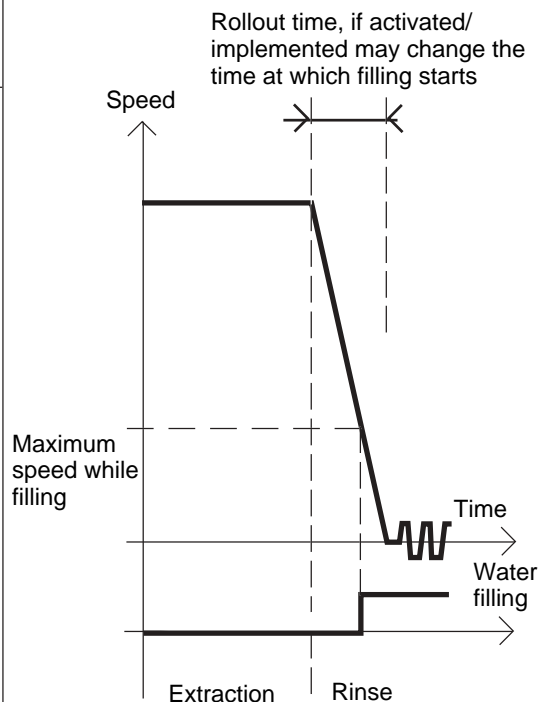

START EXTRACT SPEED	1000
DEFAULT WASH ACCELERATION	20
DISTRIBUTION ACCELERATION	9
RETERDATION ACCELERATION	
EXTRACT ACCELERATION	40
START EXTRACT ACCELERATION	40
EXTRACT RETARDATION	50
MAX SPEED DURING FILLING	100
MAX LEVEL OFFS. FOR AUT. CALIB.	
TIME AT DISTRIBUTION SPEED 2	
NUMBER OF REDIST LOW 1 UNB.	
NUMBER OF REDIST LOW 2 UNB.	
NUMBER OF REDIST MEDIUM UNB.	
NUMBER OF REDIST HIGH UNB.	
NUMBER OF REDIST EXTREME UNB.	
DRAIN TIME AT PROGR. START	
DRAIN TIME AT PROGR. END	
READY	

Max level offs. for aut. calib.
Maximum level in SKD for automatic calibration.



Use the numeric keys to enter the value.

If you make a mistake while entering digits:

Press **ERASE**.



When you have finished:

Press .

START EXTRACT SPEED	1000
DEFAULT WASH ACCELERATION	20
DISTRIBUTION ACCELERATION	9
RETARDATION ACCEL	
EXTRACT ACCELERATION	40
START EXTRACT ACCELERATION	40
EXTRACT RETARDATION	50
MAX SPEED DURING FILLING	100
MAX LEVEL OFFS. FOR AUT. CALIB.	
TIME AT DISTRIBUTION SPEED 2	
NUMBER OF REDIST LOW 1 UNB.	
NUMBER OF REDIST LOW 2 UNB.	
NUMBER OF REDIST MEDIUM UNB.	
NUMBER OF REDIST HIGH UNB.	
NUMBER OF REDIST EXTREME UNB.	
DRAIN TIME AT PROGR. START	
DRAIN TIME AT PROGR. END	
READY	

Drain time at progr. start
Drain time at program start after that the level is below level empty.



Use the numeric keys to enter the value.

If you make a mistake while entering digits:

Press **ERASE**.



When you have finished:

Press .

NUMBER OF REDIST LOW 1 UNB.
 NUMBER OF REDIST LOW 2 UNB.
 NUMBER OF REDIST MEDIUM UNB.
 NUMBER OF REDIST HIGH UNB.
 NUMBER OF REDIST EXTREME UNB.
 DRAIN TIME AT PROGR. START
DRAIN TIME AT PROGR. END
 READY

Drain time at progr. end

Drain time at program end after that the level is below level empty.

1 2 3 Use the numeric keys to
enter the value.

4 5 6

7 8 9 If you make a mistake while
entering digits:

0

Press **ERASE**.



When you have finished:

Press .

To conclude making changes in variables under "SETTINGS 2"

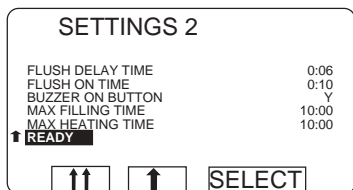

Press to highlight **READY**.

Insert a suitable strap to short-circuit terminals X7:1-2 on the CPU circuit board.

SELECT

Press **SELECT**.

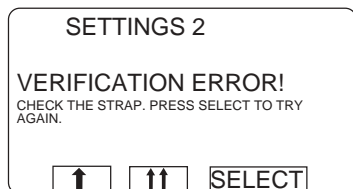

The display illustrated left will appear if you fail to insert the strap to short-circuit terminals X7:1-2.

Check that the strap between X7:1-2 is intact and in place.

Press **SELECT** and try again.



The variables will now have been stored in the PCU.

Remove the strap between terminals X7:1-2 on the CPU circuit board.

SELECT

Press **SELECT**.

To prevent inadvertent changes in variables
If you have changed any variables under "Settings 2", when you have finished keying in the changes, you need to insert a strap between two terminals on the CPU circuit board to register the changes in the CPU.

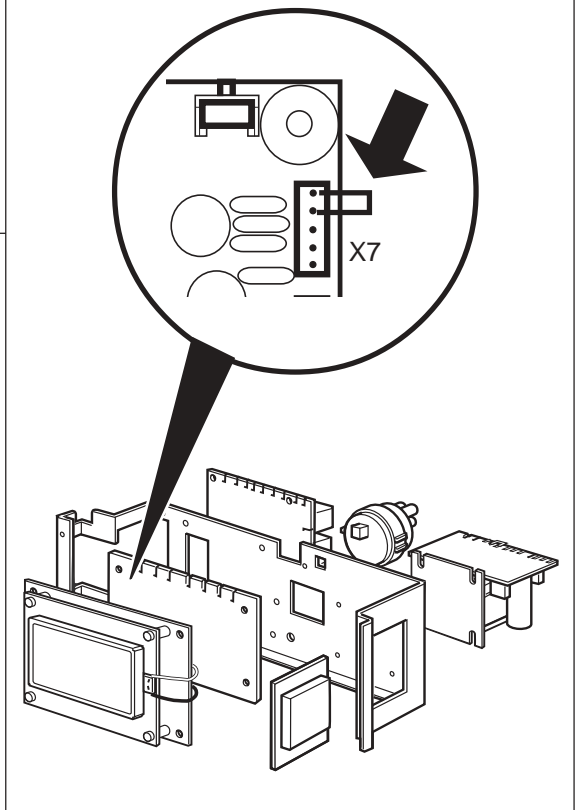

To replace the CPU board

If the CPU board is faulty and has to be replaced, the correct software for the particular washer extractor will have to be downloaded onto the new CPU board.

For this you need:

1. A new CPU circuit board.
2. A portable PC with Windows 98, NT, ME or 2000.
3. The correct cable for connecting the PC to the CPU board.
4. Software which is correct for the model of washer extractor the CPU board is to be installed in, to be downloaded onto that CPU board. These program files can be ordered from the supplier.
5. A special program called CMM G3000 (Certus Maintenance Manager), used for converting and downloading the files onto the new CPU board. This program can also be ordered from the supplier.

Instructions:

1. Order the right software for your CPU board from the supplier. You must state the type and serial number of the machine to obtain the correct version of the program. If you do not have it already, you should order the program CMM G3000 (Certus Maintenance Manager) at the same time. The programs can be supplied on diskette or via E-mail.
2. Install and open the CMM G3000.
3. In main menu click "Downloading software".
4. Click on "Browse" and select your file. Mark the file, then "open".
5. "Ready to download", click "proceed".

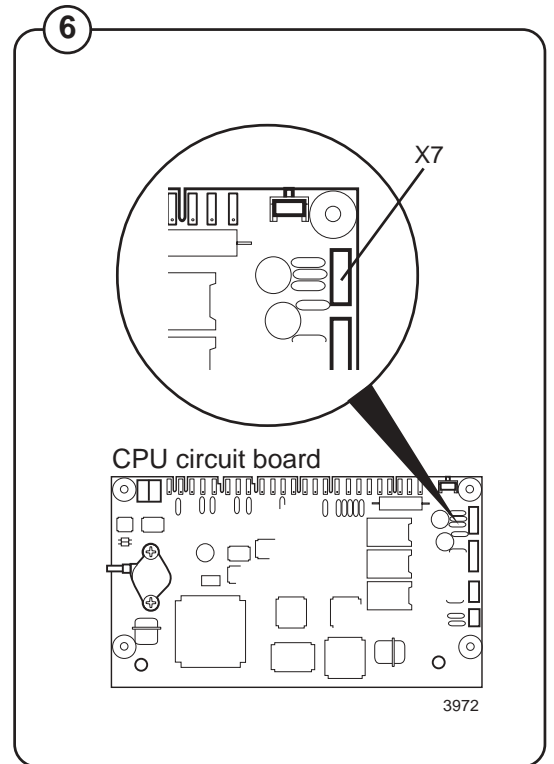

- Fig. 6**
6. Switch off the machine's main power switch. Install the new CPU board and connect all the PCB connectors. Connect the correct cable between the computer (COM1 port) and the interface connector X7 on the CPU board. Switch the machine's main power switch back on.
 7. Click OK. The downloading is started. An indication that downloading is working OK is that the two LED's at the lower left corner Red Tx and Yellow Rx are flashing within one minute.

The computer will now process and adapt the five files for downloading onto the CPU board. This will take a minute or so.



8. When downloading is finished, the PC screen will tell you that the software is OK.
9. Switch off the machine's main power switch. Remove the cable linking PC and CPU board. Switch the machine's main power switch back on. The PCU will now start up with the new software.

To replace an I/O board

The procedure described here is for machines with more than one I/O board. On machines with only one I/O board, that board can be replaced without any need for this procedure.

If there is more than one I/O circuit board, the processor must know whether the new circuit board is I/O board 1, I/O board 2 or I/O board 3. For this programming you need:



1. A portable PC with Windows 98, NT, ME or 2000.
2. The correct cable for connecting the PC to the CPU board.
3. A service program for the PCU which you can run on a PC. The program is called "CMM G3000" and can be used for numbering the I/O boards correctly, amongst other things. This program can be ordered from the supplier.

Instructions:

1. Order a copy of the program "CMM G3000" if you do not have it already. Programs can be supplied on diskette or via E-mail.
2. If you have not already installed it, install the program "CMM G3000" on your computer.
3. Switch off the machine's main power switch. Install the new I/O board and connect all the PCB connectors.
4. Switch the machine's main power switch back on. Connect the correct cable between the computer (COM1 port) and the interface connector X7 on the CPU board.

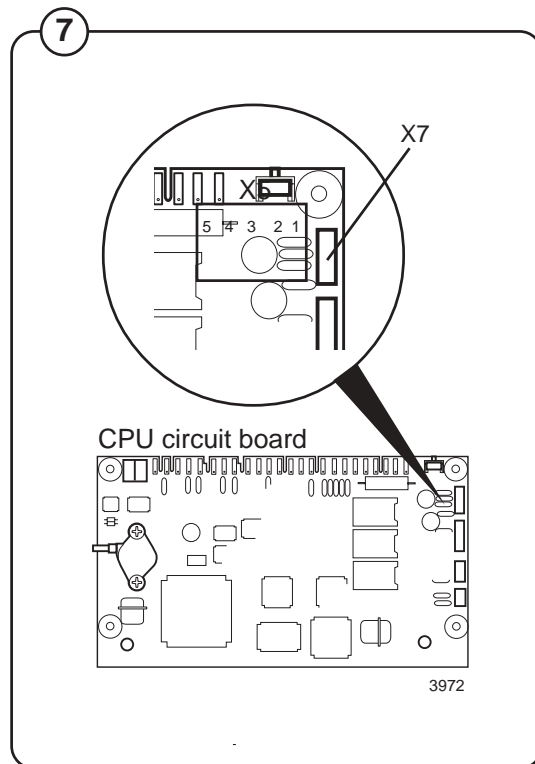
Fig. 7



It is important to ensure that the PCU is energised and running before you connect the cable to interface connector X7.

5. Start "CMM G3000".
6. A menu where various service interventions can be made is displayed.
7. Click "Service".
8. "Service menu" is shown.
9. Click I/O-board address.
10. Click I/O-board to be configured.

Fig.
8

Press the button on I/O board 1.

A confirmation will be shown on the PC-screen.

11. Continue in this fashion for other new and unprogrammed I/O boards (if present).
12. When ready, disconnect the cable between the PC and the CPU board.

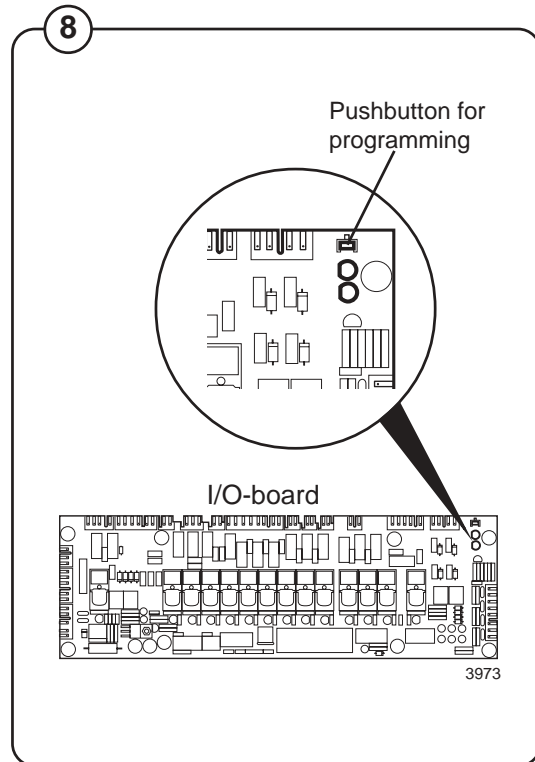

Imbalance detection

Imbalance can be split into three different types: extreme imbalance measurement, mechanical imbalance interruption and super imbalance measurement.

Extreme imbalance measurement

In a drain sequence, when the drum starts its acceleration from washing rpm to extraction rpm, the extreme imbalance measurement starts when 90% of the distribution rpm has been achieved. After this, for the remainder of the super imbalance measurement, the distribution time and throughout any subsequent extraction time, the programme detects whether extreme imbalance occurs or not.

In the event of extreme imbalance, which can occur if e.g. a spring strut is damaged or if washing is being performed in sacks, the acceleration is interrupted and it is necessary to wait for the drum to stop. If extreme imbalance occurs during:

- a. distribution or during super imbalance measurement, the drain sequence starts again from the beginning. The number of attempted restarts can be set in the system data, but is usually set to 5 attempts. This value can also be altered via configuration 2.
- b. extraction, the extraction is interrupted and the programme skips to the next washing sequence after extraction.

Mechanical imbalance interruption (detection via mechanical imbalance switch)

The same as extreme imbalance, except that if the imbalance switch is activated during a part of the washing programme that is run at washing rpm, the drum stops for a few seconds and then automatically starts up again.

Super imbalance measurement

Super imbalance measurement is the normal imbalance measurement. Its task is to ensure that the machine is not overloaded during extraction, as well as to ensure that the number of missed extractions is as small as possible.

Super imbalance measurement starts a few seconds after the drum has reached distribution rpm. The delay is there to allow the motor rpm to 'settle down' so that it is as stable as possible.

The magnitude of the imbalance is measured and compared first with a fairly low imbalance limit value 1. If the imbalance exceeds this limit value, the drum is slowed down to a lower rpm in order to achieve redistribution of the clothes. It then accelerates again without stopping at the distribution rpm again, after which a new imbalance measurement is carried out. The number of attempts at limit value 1 may be set in the system data and can also be altered in configuration 2. The value is normally set at 3.

If the imbalance is below the limit value, extraction starts at the extraction speed specified in the programme after the distribution time has elapsed.

If the imbalance still does not drop below limit value 1 after three attempts, the imbalance is instead compared with a slightly higher permitted imbalance value, limit value 2. If the imbalance exceeds this limit value, the drum is slowed down to a lower rpm in order to achieve redistribution of the clothes. It then accelerates again without stopping at the distribution rpm again, after which a new imbalance measurement is carried out. The number of attempts at limit value 2 may be set in the system data and can also be altered in configuration 2. The value is normally set at 2.

If the imbalance is suddenly lower than one of the two limit values, the extraction starts with the extraction speed programmed in the programme. The reason for the use of two limit values, both of which produce the same extraction rpm, is that in order to look after the machine's mechanism, it is desirable in the first instance to extract with as low an imbalance as possible.

In the same way as above, the imbalance is compared with a further two limit values, limit value 3 and limit value 4. However, each of these gives a reduced extraction rpm if the imbalance is below the limit value. The number of attempts at limit values 3 and 4 may be set in the system data and can also be altered in configuration 2. The value for each is normally set at 2.

It should be noted that even if imbalances have occurred continually that are so large that the comparison is made with limit value 4, and the imbalance suddenly drops below limit value 1, full extraction speed will be executed.

The distribution time programmed into the drain module does not count down during the time imbalance measurement is in progress. The countdown only starts when an approved imbalance value has been achieved.

In the event that an approved imbalance value is never achieved, the drain sequence is interrupted, any subsequent extraction is skipped and the next washing sequence in the washing programme will be executed.

Note that the imbalance measurement is always carried out if the distribution rpm has been programmed in a drain module. In other words, irrespective of whether the drain module is followed by extraction or not. If a drain module is not followed by an extraction, it is necessary to avoid programming the drain module with distribution rpm as the imbalance measurement will then be carried out. This takes time, approximately 40 seconds in the best case scenario, although in the worst case scenario, if limit value 4 has to be used, it can take several minutes.

29. Door and door lock

Contents

Description, W365H, W375H up to machine No. –520/19486 and 520/19549-22806 W3105H up to machine No. –595/9040 W3130H up to machine No. –650/14354 W3180H up to machine No. –725/7908 W3240H up to machine No. –795/3769	3
General	3
Function	4
The door lock locks the door	4
The door lock unlocks the door	5
Error codes	6
Reset button	7
Door lock control inputs/outputs	7
Repairs.....	10
Emergency opening of door lock.....	10
Replacing the door lock.....	11
Description, W365H, W375H from machine No. 520/22807– and 520/19487-19548 W3105H from machine No. 595/9041– W3130H from machine No. 650/14355– W3180H from machine No. 725/7909– W3240H from machine No. 795/3770– W3300H	12
General	12
Function	13
The door lock locks the door	13
The door lock unlocks the door	14
Error codes	15
Reset button	16
Door lock control inputs/outputs	16
Repairs.....	19
Emergency opening of door lock.....	19
Replacing the door lock.....	20

Description

W365H, W375H
Up to machine No. -520/19486
and 520/19549-22806

W3105H Up to machine No. -595/9040
W3130H Up to machine No. -650/14354
W3180H Up to machine No. -725/9708
W3240H Up to machine No. -795/3769

General

The door lock part consists of the following:

Fig. 1

1

- **Door lock A41** that contains
 - an **actuator** that locks the door lock and which also has two built-in micro switches, S4a and S4b. The actuator is bi-stable, i.e., it has two stable positions: locked door and unlocked door. The actuator must receive a pulse to lock and unlock the door lock. S4a and S4b are both closed when the door is locked.
 - **micro switch S3** that is closed when the door is closed.
 - An **emergency opening arm/emergency opening button** that can be used to open the door lock in an emergency.

Fig. 2

2

- **Door lock control A31** that is situated in the front control unit of the machine. This card controls the door lock function and whether the drum is empty and not rotating. It locks and unlocks the door lock when the programme unit requests door locking or unlocking.

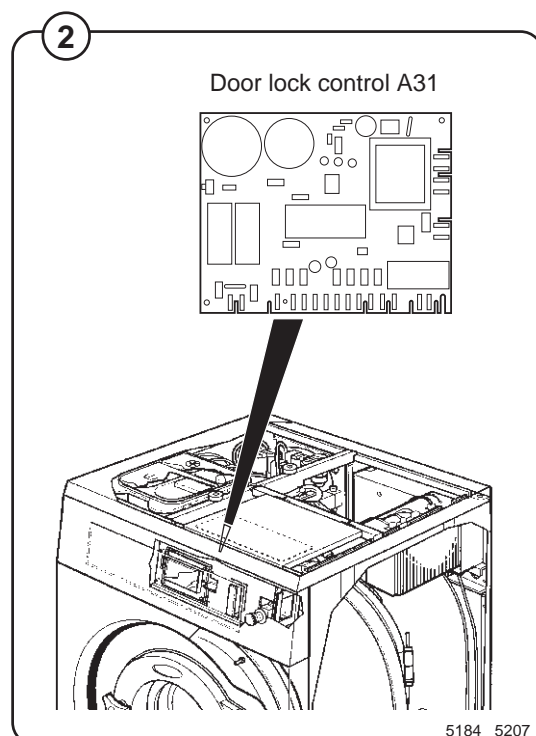
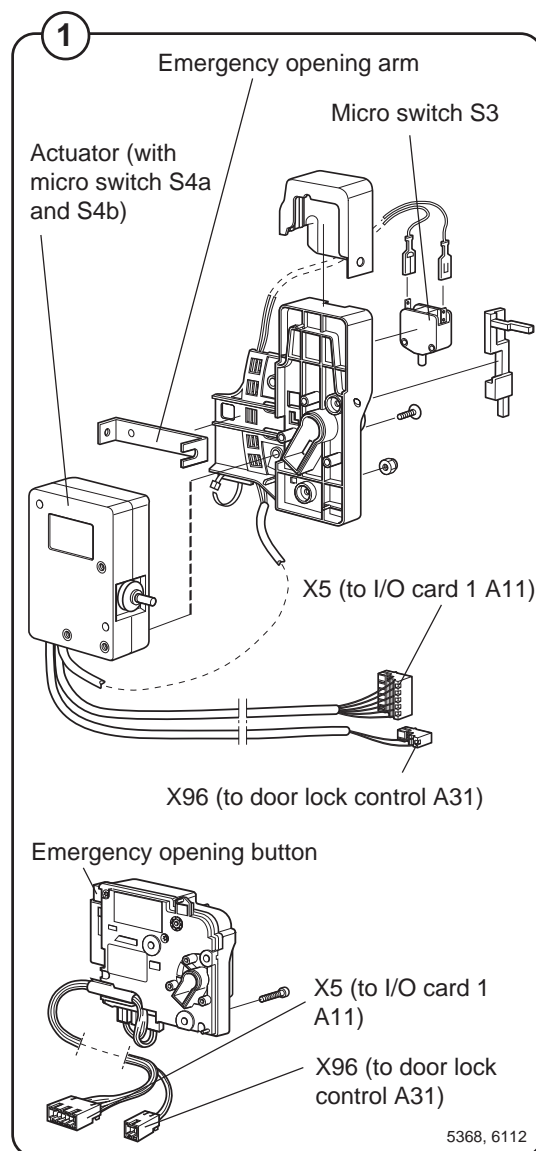

Function

The door lock locks the door

Fig. 3 When the door is closed (closed door lock switch S3), the programme unit may request door locking by applying a voltage of 200-240 V on door lock controller A31 input X92.

The following check is made by the A31 card prior to locking of the door:

- **No water in drum** - input X93 from level guard B2 is closed = 0 V
- **Motor not engaged** - input X94 from motor control U1 open = 5 V
- **Drum not rotating** - pulse frequency on input X95 from rotation sensor B3 less than 0.4 Hz.

When the above conditions are met, the card A31 outputs a closing pulse on output X96 to the door lock actuator/coil, which then locks the door. The micro switches S4a and S4b in the actuator/door lock are closed when the door is locked. These micro switches feed voltage to:

- **The output relays** on I/O card 1. The relays govern the machine's drain and water valves as well as heater switch-on.
- **Interlock signal** for motor control (input X302 via I/O card 1) that releases the motor start prevention state.

Programme operation is now possible.

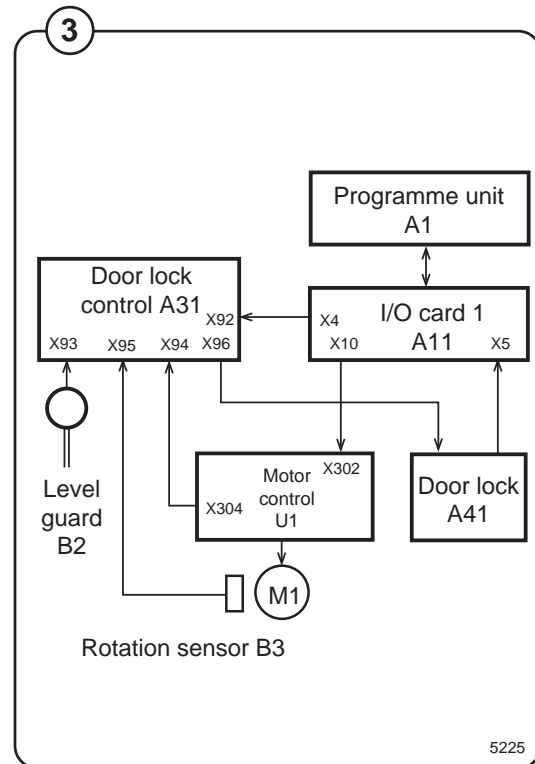

The door lock unlocks the door

Fig. 4 The programme unit requests door unlocking by applying 0 V on input X92 of the door lock controller.

The following check is made prior to unlocking of the door:

- **No water in drum** - input X93 from level guard B2 is closed = 0 V
- **Motor not engaged** - input X94 from motor controller U1 open = 5 V
- **Drum not rotating** - pulse frequency on input X95 from rotation sensor B3 less than 0.4 Hz.

When the above conditions are met, the door lock controller outputs an opening pulse on output 96 to the door lock actuator/coil, which then unlocks the door. Micro switches S4a and S4b now interrupt the actuator/door lock and the I/O card 1 relays lose all voltage to prevent the motor from starting (interlock signal on motor controller input X302). The drain and water valves of the machine are now disabled and the heater and motor cannot be switched on.

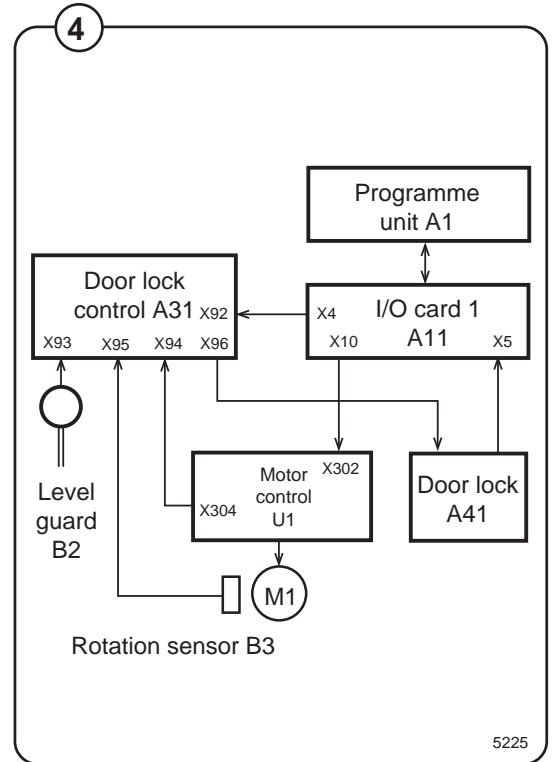

Error codes

Fig. 5 The door lock control has three LEDs that show whether the door lock operates normally or whether an error has been detected. During normal operation, the LEDs blink when the drum is not turning and are off when the drum rotates. In case of an error, the three LEDs will show the error condition according to the table below. Any error codes are automatically cleared 5 minutes after the error has been remedied. In case the error occurred at the end of the programme, the door also unlocks after 5 minutes.

LEDs			Normal operation
A	B	C	
●	●	●	No error. The drum is not turning (no water in drum) (- - -)
●	●	●	Level switch B2 indicates water in drum when drum is stand-still (- - - - -)
○	○	○	No error. The drum is rotating

LEDs			Error state
A	B	C	
●	●	○	Level guard B2 indicates water in drum when the door lock is open (input X93 open).
○	●	●	Motor control indicates that motor is operating when door lock is open (input X94 closed).
●	○	○	No signal from rotation sensor B3 (frequency input X95 < 0.4 Hz) in spite of the motor control indicating motor operation.
○	●	○	No signal from motor control (input X94 open) in spite of rotation sensor B3 indicating motor operation (frequency input X95 > 0.4 Hz).
●	○	●	Error in drive circuits for door lock (output X96) or error in door lock/cable harness for the door lock.
○	○	●	Internal error in the door lock control.

○ = no lit, ● = lit

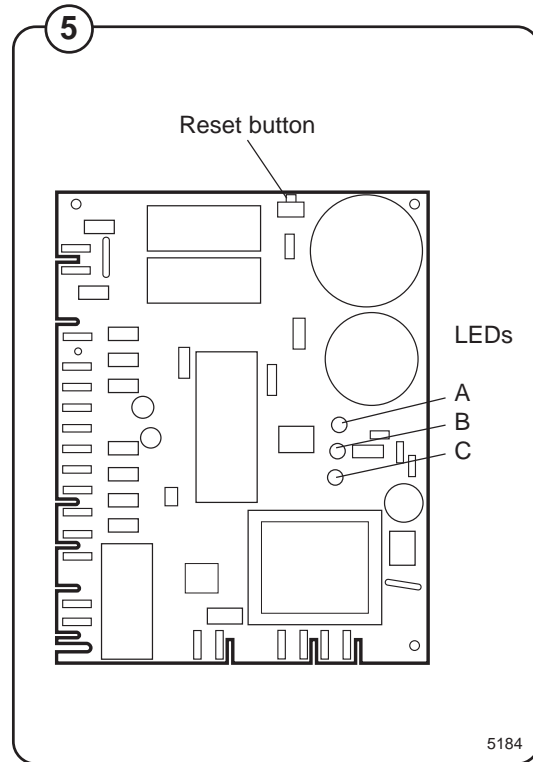

Reset button

Fig. 5 The door lock control features a reset button used to reset the programme routines stored in the computer. When pressed, any error codes are erased;

Door lock control inputs/outputs

Fig. 6 **X90: AC 200-240 V feed**

6 **X91: Transfer of voltage supply**

Fig. 7 Feeds the voltage to programme unit A1.

7 **X92: Input from programme unit (via I/O card 1): Lock door**

Prior to the door lock controller locking the door (output X96), a check is made of any water left in the drum (input X96 closed) and whether the drum is not rotating (input X94 open).

Input voltage	Function
200-240 V DC:	Programme unit requests door locking
0 V:	Programme unit requests door opening

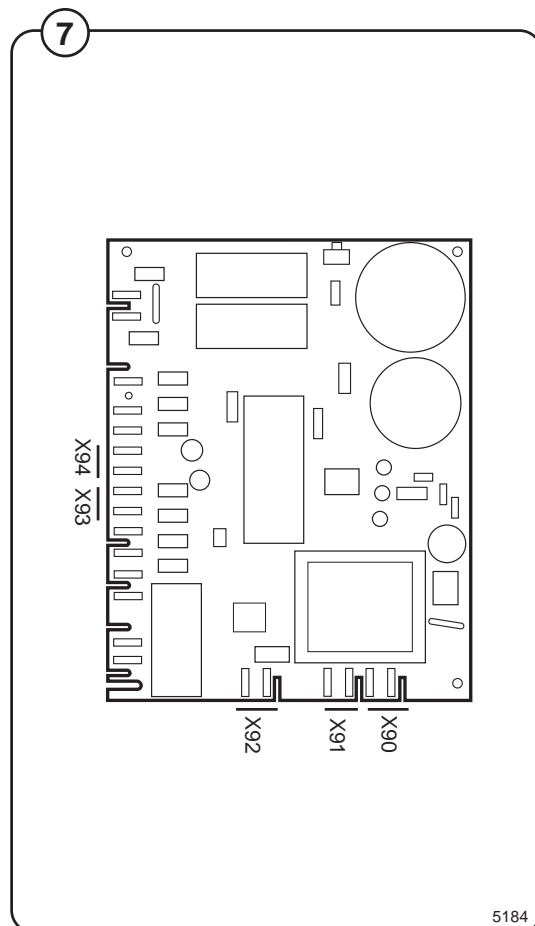
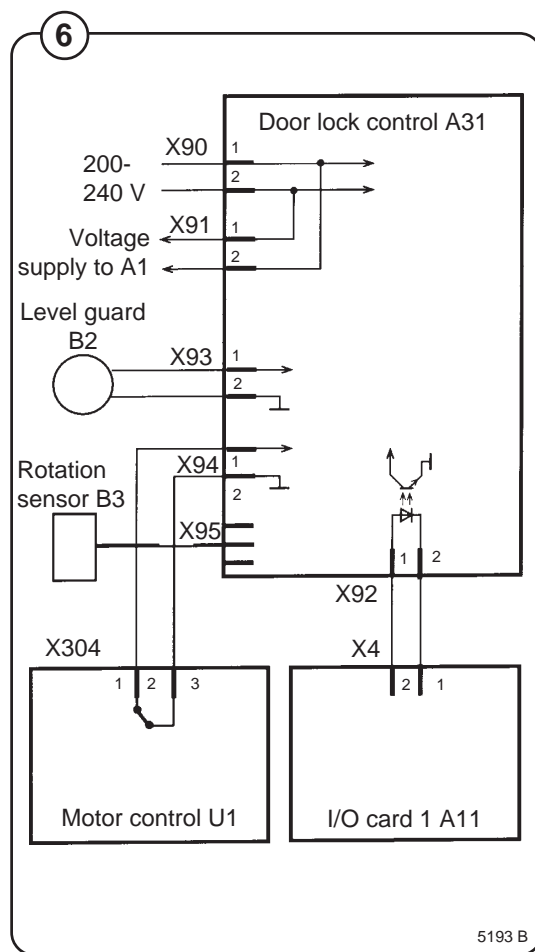

Fig. 8 X93: Input from level guard

8 If the input indicates “Water in drum” when the door is not locked, the door cannot be locked. The LEDs then show the error code ● ● ○.

9 If the input indicates “Water in drum” when the door is not locked, the door cannot be locked. The LEDs then show the error code ● ● ○.

Input voltage	Function
5 V DC:	Water in drum (level guard open)
0 V:	Drum empty (level guard closed)

X94: Input from motor control

Only when door is open

If the input indicates “Motor operating”, the door cannot be locked. The LEDs then show the error code ○ ● ●.

Only when door is locked

The input signal from X94 is compared with the signal from the rotation sensor B3 (input X95).

If the motor is operating, but the rotation sensor does not provide a signal, error code ● ○ ○ is shown.

If the rotation sensor indicates motor operation when the motor is not operating, error code ○ ● ○ is shown.

Input voltage	Function
5 V DC:	Motor not operating (input open)
0 V:	Motor operating (input closed)

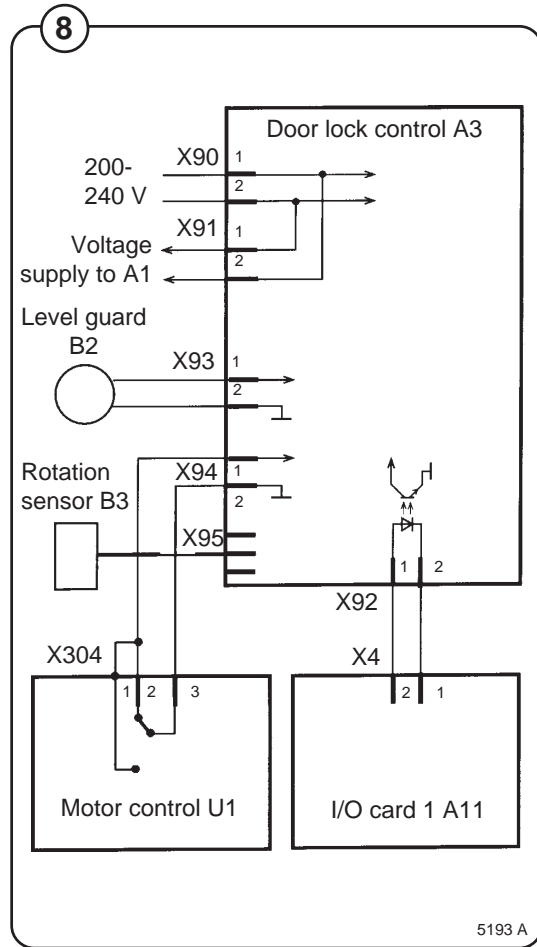

5193 A

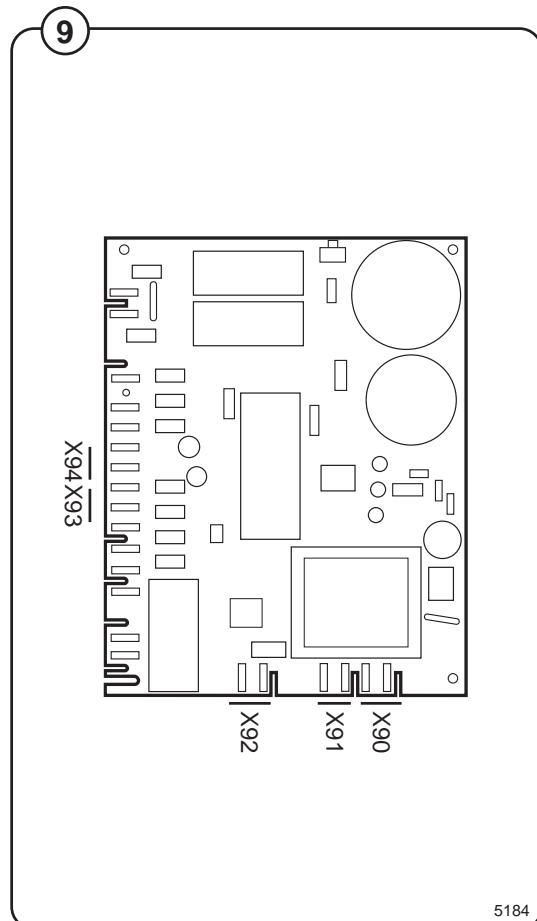

5184

Fig. 10 X95: Input from rotation sensor on motor shaft

Fig. 11 When the motor is operating, a pulse train is applied on the input.

Input	Function
Pin 1:	DC 4-10 V feed
Pin 2:	0V
Pin 3:	DC 4-10 V pulse input Frequency > 0.4 Hz: drum is rotating Frequency < 0.4 Hz: drum is not rotating

X96: Output to door lock

Locks the door lock when the following conditions are met:

- DC 200-240 V on input X92 (programme unit request door locking)
- DC 0 V on input X93 (no water in drum)
- DC +5 V on input X94 (motor not activated)
- <0.4 Hz on input X95 (drum not rotating)
- No error code present

Unlocks the door lock when the following conditions are met:

- DC 0 V on input X92 (programme unit request door opening)
- DC 0 V on input X93 (no water in drum)
- DC +5 V on input X94 (motor not activated)
- <0.4 Hz on input X95 (drum not rotating)
- No error code present

Voltage	Function
DC 17-31 V, + on pin 1, - on pin 2	Unlock the door
DC 17-31 V, - on pin 1, + on pin 2	Locks the door

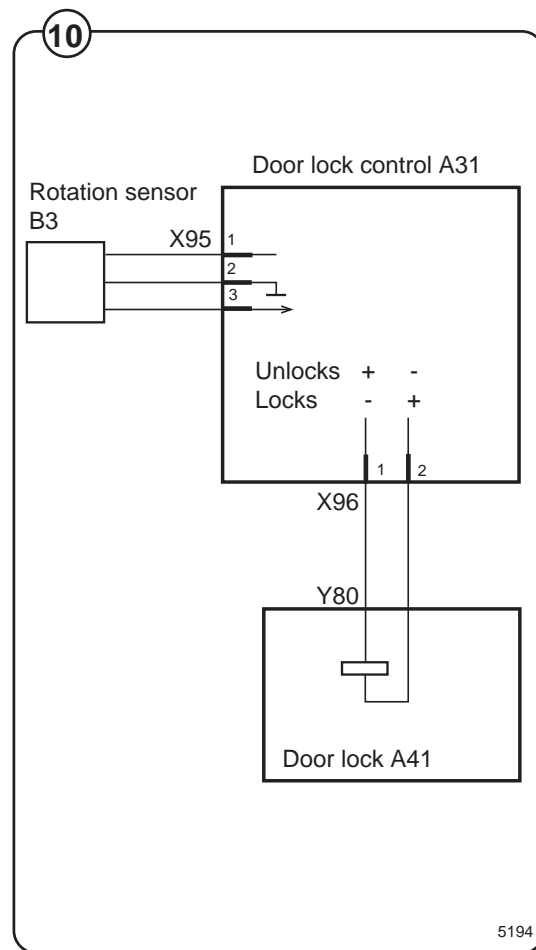

5194

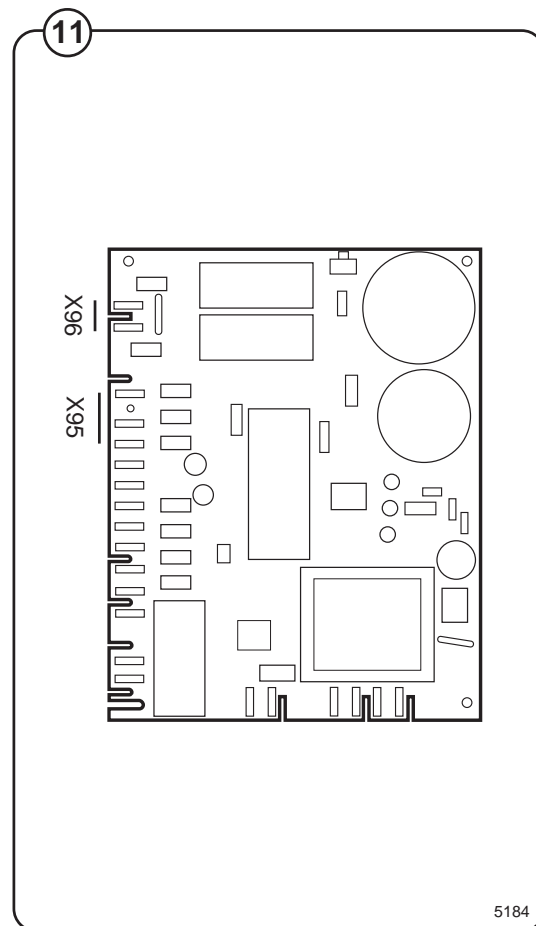

5184

Repairs



Repair work on the machine should only be done by specially trained personnel.

Emergency opening of door lock

- Fig. 12
1. Switch off power to the machine by turning the main power switch to the 0 position.
 2. Remove the front cover or top cover. When replacing the door lock, it is recommended to remove the front cover.
 3. Pull the emergency opening arm to the side. This retracts the spring-loaded locking pin and the door lock opens.
Alt. Press down the emergency opening button.

12

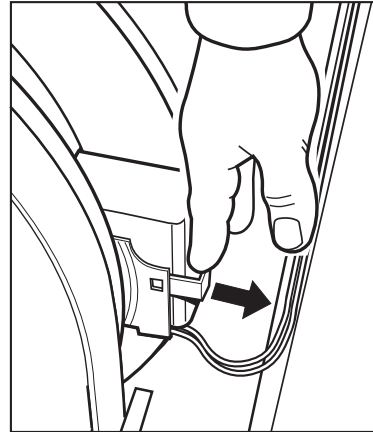

5369

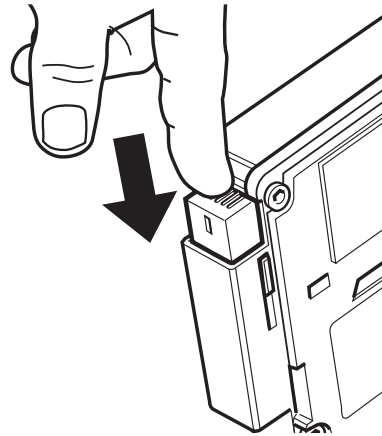

6111

Replacing the door lock

1. Switch off power to the machine by turning the main power switch to the 0 position.
2. Remove the front cover alt. side pole.
3. Remove the door (two screws in each hinge).
4. Remove the front panel.
5. Remove the door lock (three holding screws).
6. Verify the strap positions on the cable for the lock. Cut open the necessary straps to undo the cables leading to the lock.
7. Undo the connectors.
8. Replace the door lock.
9. Reconnect the new door lock.
10. Assemble in reverse order.
11. Strap the cables for the lock according to the notes made in step 6.

Description

W365H, W375H
from machine No. 520/22807–
and 520/19487-19548

W3105H from machine No. 595/9041–
W3130H from machine No. 650/14355–
W3180H from machine No. 725/7909–
W3240H from machine No. 795/3770–
W3300H

General

The door lock part consists of the following:

Fig.
13

- **Door lock A41** that contains
 - an **actuator** that locks the door lock and which also has two built-in micro switches, S4a and S4b. The actuator is bi-stable, i.e., it has two stable positions: locked door and unlocked door. The actuator must receive a pulse to lock and unlock the door lock. S4a and S4b are both closed when the door is locked.
 - **micro switch S3** that is closed when the door is closed.
 - An **emergency opening arm/emergency opening button** that can be used to open the door lock in an emergency.

Fig.
14

- **Door lock control A31** that is situated in the front control unit of the machine. This card controls the door lock function and whether the drum is empty and not rotating. It locks and unlocks the door lock when the programme unit requests door locking or unlocking.

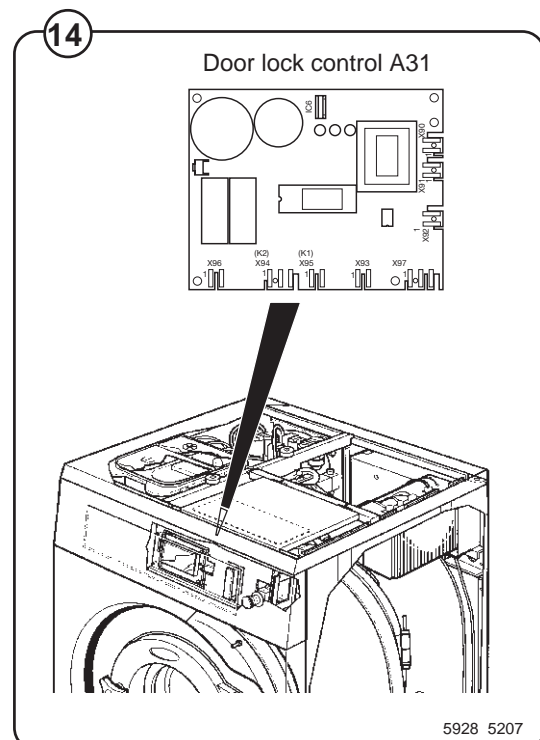
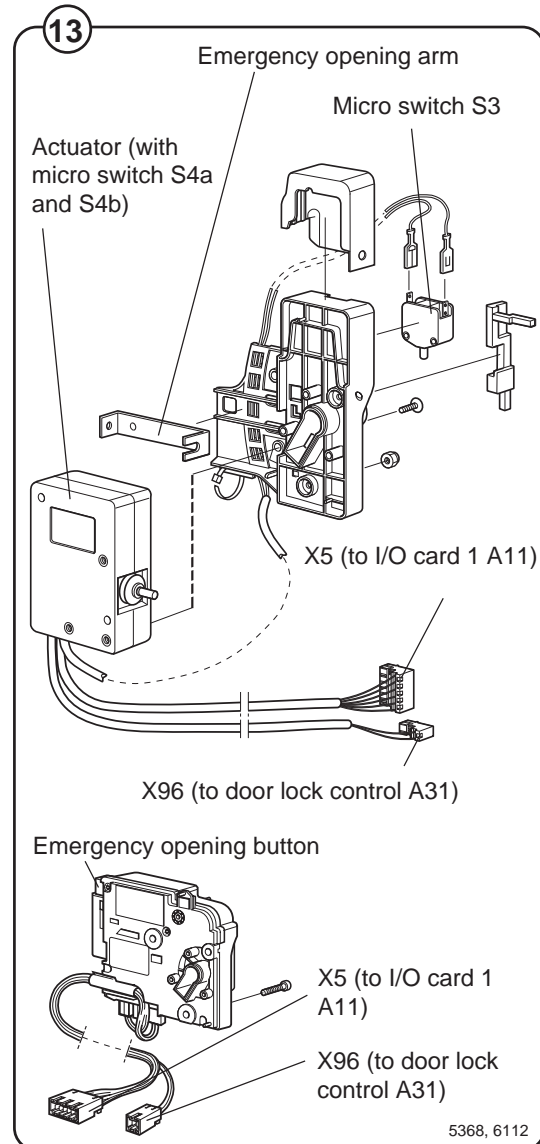

Function

The door lock locks the door

Fig. 15 When the door is closed (closed door lock switch S3), the programme unit may request door locking by applying a voltage of 200-240 V on door lock controller A31 input X92.

The following check is made by the A31 card prior to locking of the door:

- **No water in drum** - input X93 from level guard B2 is closed = 0 V
- **Motor not engaged** - input X94 from motor control U1 open = 5 V
- **Drum not rotating** - pulse frequency on input X95 from rotation sensor B3 less than 3 Hz.

When the above conditions are met, the card A31 outputs a closing pulse on output X96 to the door lock actuator/coil, which then locks the door. The micro switches S4a and S4b in the actuator/door lock are closed when the door is locked. These micro switches feed voltage to:

- **The output relays** on I/O card 1. The relays govern the machine's drain and water valves as well as heater switch-on.
- **Interlock signal** for motor control (input X302 via I/O card 1) that releases the motor start prevention state.

Programme operation is now possible.

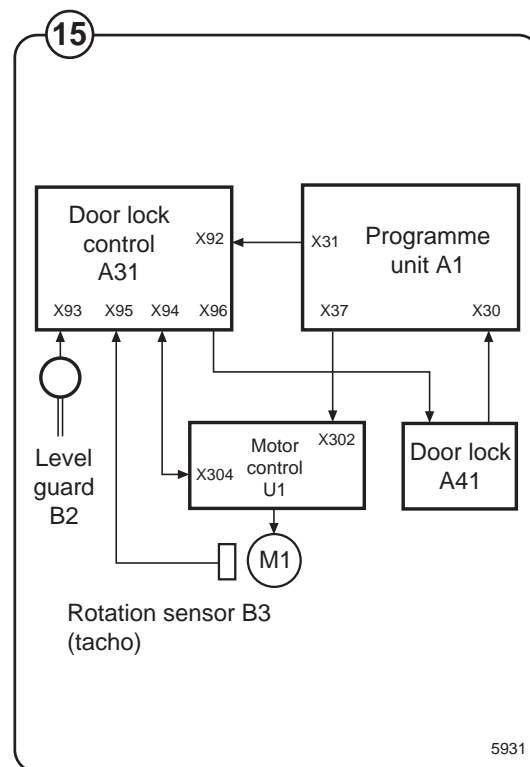

The door lock unlocks the door

Fig. 16 The programme unit requests door unlocking by applying 0 V on input X92 of the door lock controller.

The following check is made prior to unlocking of the door:

- **No water in drum** - input X93 from level guard B2 is closed = 0 V
- **Motor not engaged** - input X94 from motor controller U1 open = 5 V
- **Drum not rotating** - pulse frequency on input X95 from rotation sensor B3 less than 3 Hz.

When the above conditions are met, the door lock controller outputs an opening pulse on output 96 to the door lock actuator/coil, which then unlocks the door. Micro switches S4a and S4b now interrupt the actuator/door lock and the I/O card 1 relays lose all voltage to prevent the motor from starting (interlock signal on motor controller input X302). The drain and water valves of the machine are now disabled and the heater and motor cannot be switched on.

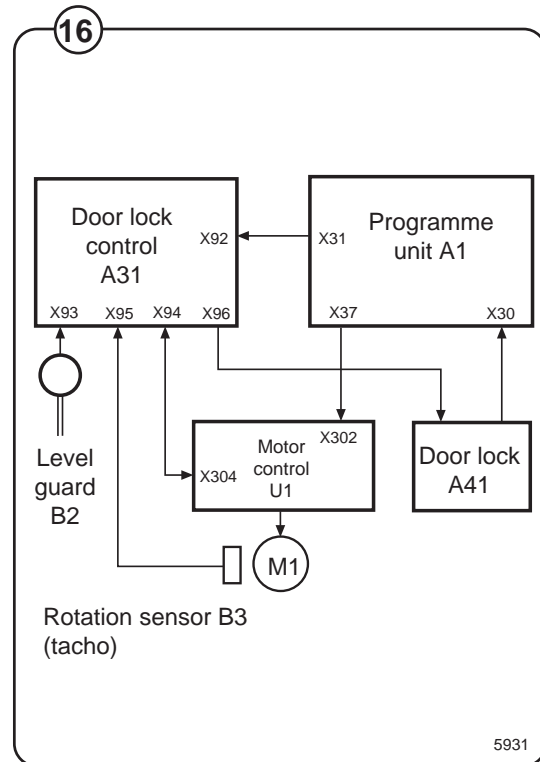

Error codes

Fig. 17 The door lock control has three LEDs that show whether the door lock operates normally or whether an error has been detected. During normal operation, the LEDs blink when the drum is not turning and are off when the drum rotates. In case of an error, the three LEDs will show the error condition according to the table below. Any error codes are automatically cleared 5 minutes after the error has been remedied. In case the error occurred at the end of the programme, the door also unlocks after 5 minutes.

LEDs			Normal operation
A	B	C	
●	●	●	No error. The drum is not turning (no water in drum) (- - -)
●	●	●	Level switch B2 indicates water in drum when drum is stand-still (-- -- --)
○	○	○	No error. The drum is rotating

LEDs			Error state
A	B	C	
●	●	○	Level guard B2 indicates water in drum when the door lock is open (input X93 open).
○	●	●	Motor control indicates that motor is operating when door lock is open (input X94 closed).
●	○	○	No signal from rotation sensor B3 (frequency input X95 < 3 Hz) in spite of the motor control indicating motor operation.
○	●	○	No signal from motor control (input X94 open) in spite of rotation sensor B3 indicating motor operation (frequency input X95 > 3 Hz).
●	○	●	Error in drive circuits for door lock (output X96) or error in door lock/cable harness for the door lock.
○	○	●	Internal error in the door lock control.

○ = no lit, ● = lit

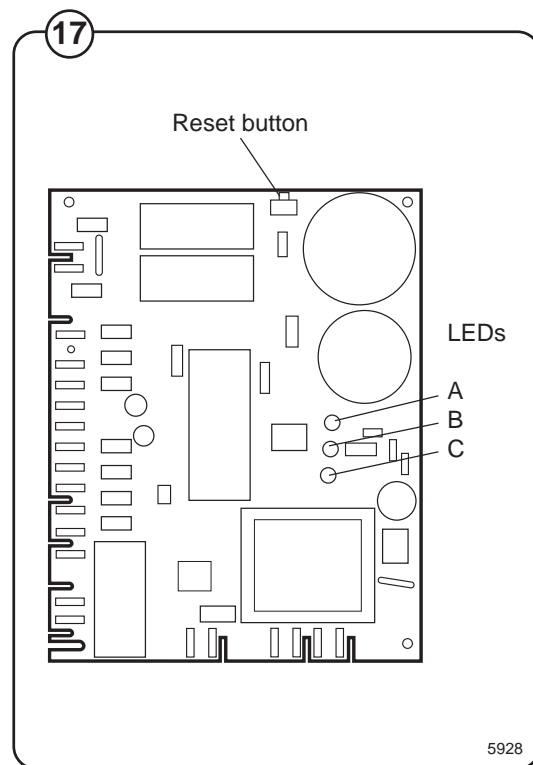

Reset button

The door lock control features a reset button used to reset the programme routines stored in the computer. When pressed, any error codes are erased;

Door lock control inputs/outputs

Fig. 18 **X90: AC 200-240 V feed**

Fig. 18 **X91: Transfer of voltage supply**
 Feeds the voltage to programme unit A1.

Fig. 19

X92: Input from programme unit (via I/O card 1): Lock door

Prior to the door lock controller locking the door (output X96), a check is made of any water left in the drum (input X96 closed) and whether the drum is not rotating (input X94 open).

Input voltage	Function
200-240 V DC:	Programme unit requests door locking
0 V:	Programme unit requests door opening

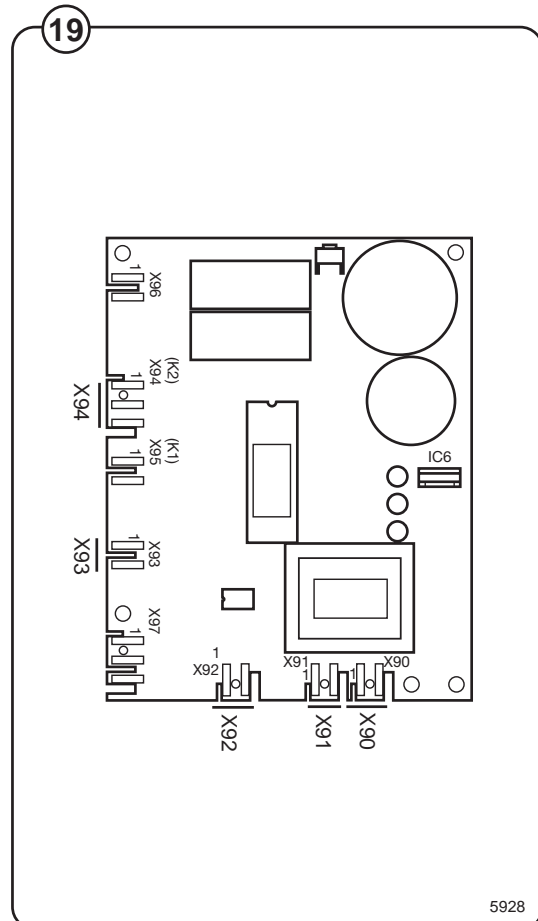
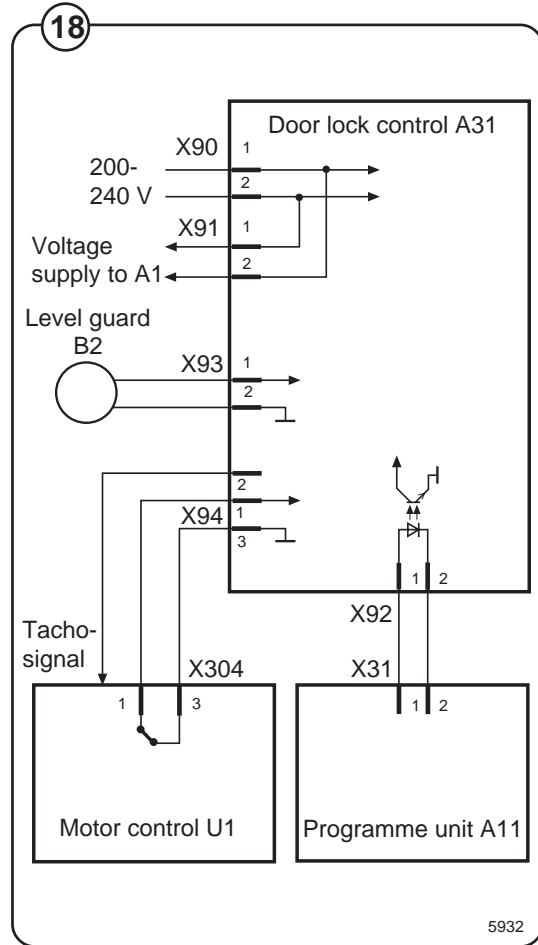

Fig. 20 X93: Input from level guard

If the input indicates “Water in drum” when the door is not locked, the door cannot be locked.

Fig. 21

The LEDs then show the error code ● ● ○.

Input voltage	Function
5 V DC:	Water in drum (level guard open)
0 V:	Drum empty (level guard closed)

X94: Input from motor control

Only when door is open

If the input indicates “Motor operating”, the door cannot be locked. The LEDs then show the error code ○ ● ●.

Only when door is locked

The input signal from X94 is compared with the signal from the rotation sensor B3 (input X95).

If the motor is operating, but the rotation sensor does not provide a signal, error code ● ○ ○ is shown.

If the rotation sensor indicates motor operation when the motor is not operating, error code ○ ● ○ is shown.

Input voltage	Function
5 V DC:	Motor not operating (input open)
0 V:	Motor operating (input closed)

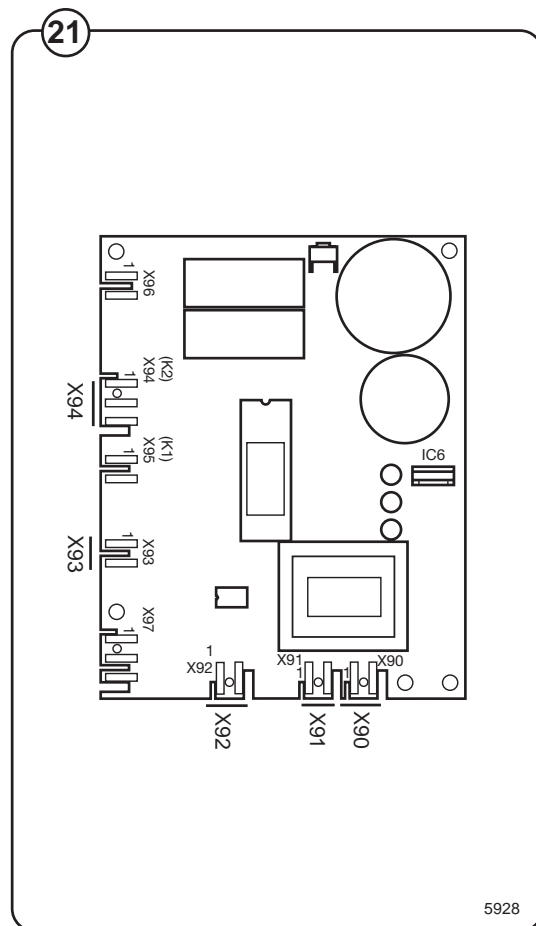
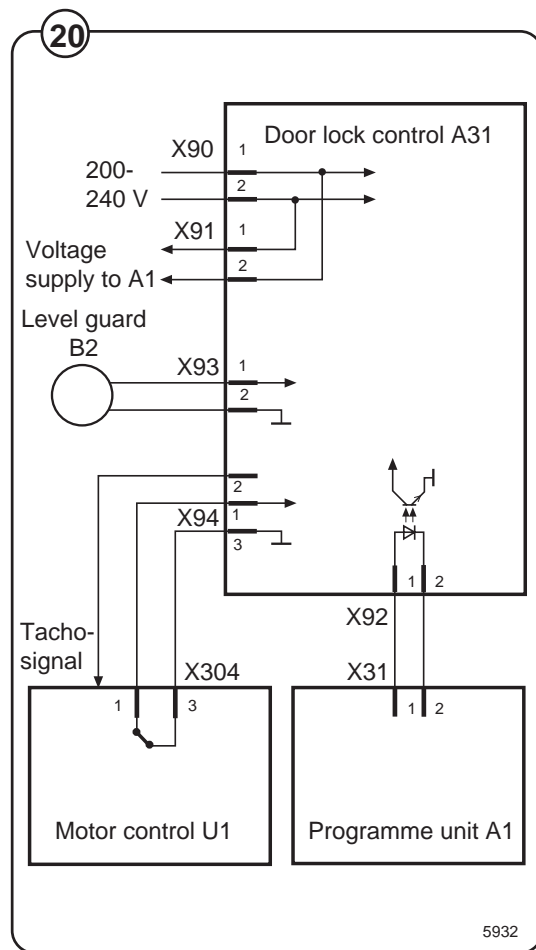

Fig. 22 X95: Input from rotation sensor on motor shaft

Fig. 23 When the motor is operating, a pulse train is applied on the input.

Input	Function
Pin 1:	0 V
Pin 2:	Tacho signal

X96: Output to door lock

Locks the door lock when the following conditions are met:

- DC 200-240 V on input X92 (programme unit request door locking)
- DC 0 V on input X93 (no water in drum)
- DC +5 V on input X94 (motor not activated)
- <3 Hz on input X95 (drum not rotating)
- No error code present

Unlocks the door lock when the following conditions are met:

- DC 0 V on input X92 (programme unit request door opening)
- DC 0 V on input X93 (no water in drum)
- DC +5 V on input X94 (motor not activated)
- <3 Hz on input X95 (drum not rotating)
- No error code present

Voltage	Function
DC 17-31 V, + on pin 1, - on pin 2	Unlock the door
DC 17-31 V, - on pin 1, + on pin 2	Locks the door

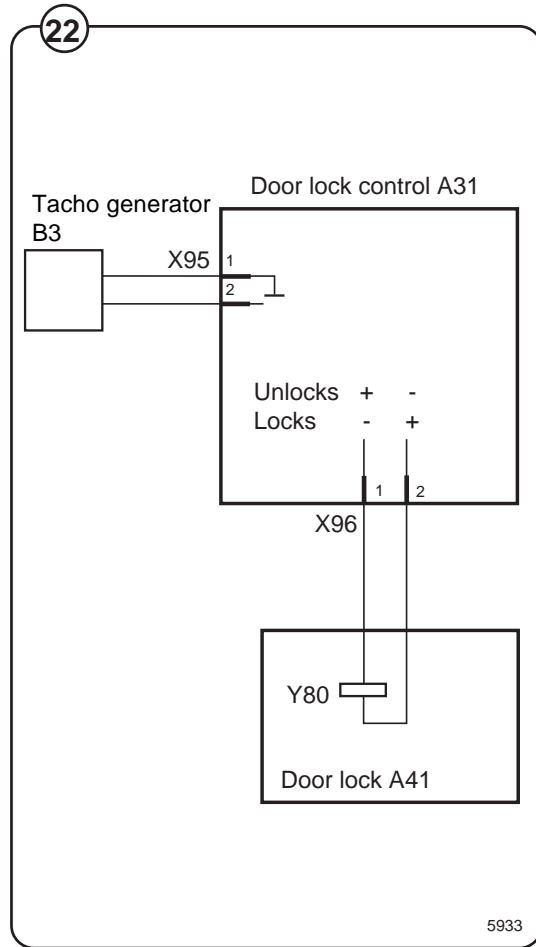

5933

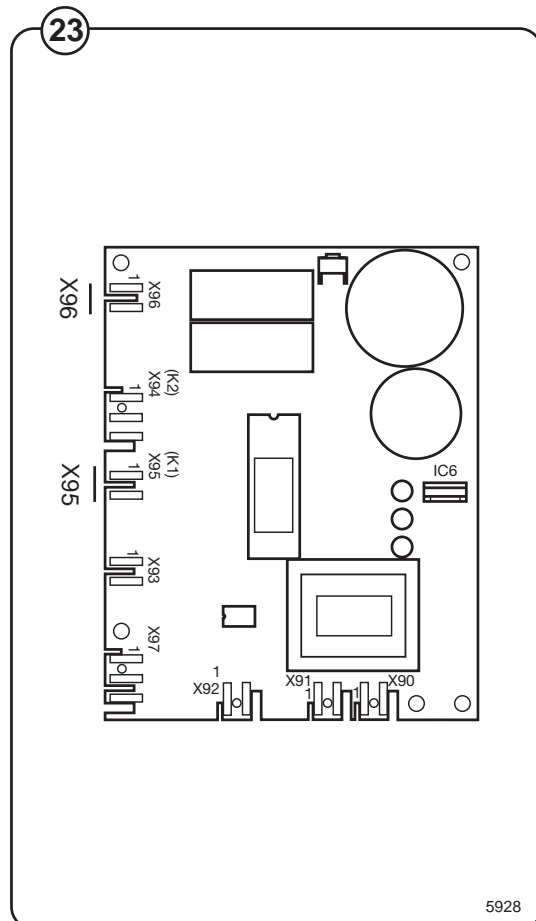

5928

Repairs



Repair work on the machine should only be done by specially trained personnel.

Emergency opening of door lock

- Fig. 24
1. Switch off power to the machine by turning the main power switch to the 0 position.
 2. Remove the front cover or top cover. When replacing the door lock, it is recommended to remove the front cover.
 3. Pull the emergency opening arm to the side. This retracts the spring-loaded locking pin and the door lock opens.
Alt. Press down the emergency opening button.

24

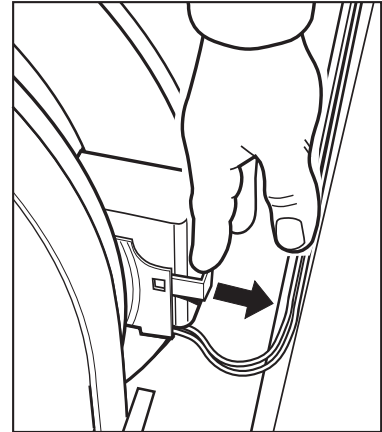

5369

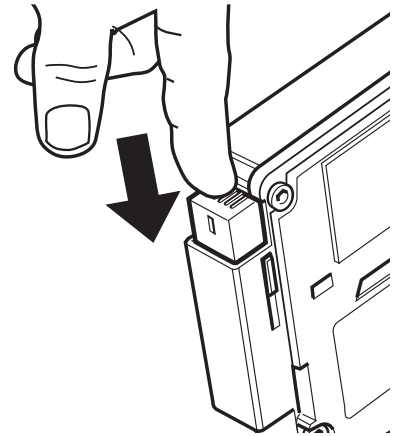

6111

Replacing the door lock

1. Switch off power to the machine by turning the main power switch to the 0 position.
2. Remove the front cover alt. side pole.
3. Remove the door (two screws in each hinge).
4. Remove the front panel.
5. Remove the door lock (three holding screws).
6. Verify the strap positions on the cable for the lock. Cut open the necessary straps to undo the cables leading to the lock.
7. Undo the connectors.
8. Replace the door lock.
9. Reconnect the new door lock.
10. Assemble in reverse order.
11. Strap the cables for the lock according to the notes made in step 6.

30. Motor and motor control

Contents

Warnings	3
Description, W365H, W375H up to machine No. -520/19486 and 520/19549-22806 W3105H up to machine No. -595/9040 W3130H up to machine No. -650/14354 W3180H up to machine No. -725/7908 W3240H up to machine No. -795/3769.....	4
Motor	4
Motor control.....	5
Function.....	6
Inputs and outputs	7
LED indications.....	10
Repairs	11
Motor replacement	11
Adjustments	12
Drive belt tension.....	12
Description, W365H, W375H from machine No. 520/22807- and 520/19487-19548 W3105H from machine No. 595/9041- W3130H from machine No. 650/14355- W3180H from machine No. 725/7909- W3240H from machine No. 795/3770- W3300H	13
Motor	13
Motor control.....	14
Function.....	15
Inputs and outputs	16
LED indications.....	19
Repairs	20
Motor replacement	20
Adjustments	21
Drive belt tension.....	21

Warnings



DANGER



Be careful when measuring the electric components in the motor control. All components have a potential difference of approx. 300 V in relation to protective earth and neutral. When the green LED on the motor control card is lit, the components carry dangerous voltages. The motor control lose all voltage about 10-30 seconds after the voltage has been disconnected and the motor has stopped.

Description

W365H, W375H

Up to machine No. -520/19486
and 520/19549-22806

W3105H Up to machine No. -595/9040
W3130H Up to machine No. -650/14354
W3180H Up to machine No. -725/7908
W3240H Up to machine No. -795/3769

Motor

Fig. 1 The motor is fitted in a bridge carrier under the outer drum. It drives the washing drum using a drive belt.

The motor is frequency-controlled and is controlled by microcomputer control. The various speeds for normal operation, distribution speeds and extraction as well as acceleration/retardation can be controlled with a high degree of precision.

The motor winding is protected against overloads using a thermal overheating protector that is automatically reset.

Fig. 1 The motor is connected directly to the motor control via a cable with quick connectors.

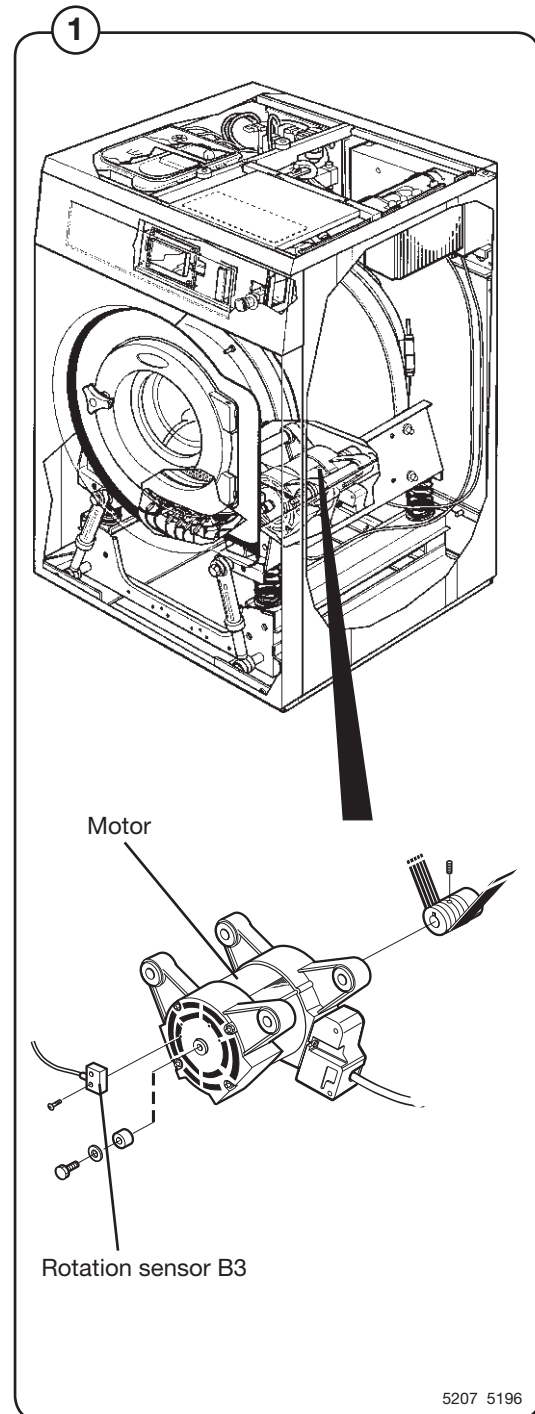

Motor control

Fig. 2 The motor control unit is microcomputer controlled and is situated under the top cover of the machine, right above the outer drum.

The unit consists of a PCB (mother board) fitted on a heat sink that does double-duty as part of the housing. In the cover there is a choke coil together with the cable harness and contact.

Fig. 2 The cable harness is directly connected to the PCB, voltage supply input and the voltage supply to the motor using connectors; the other cables are connected with flat connectors to the PCB.

A detailed description of input and output cables is presented in the section "Function".

Depending on the machine size, this unit comes in four different versions. The units have different sizes in order to be able to control motors of different sizes.

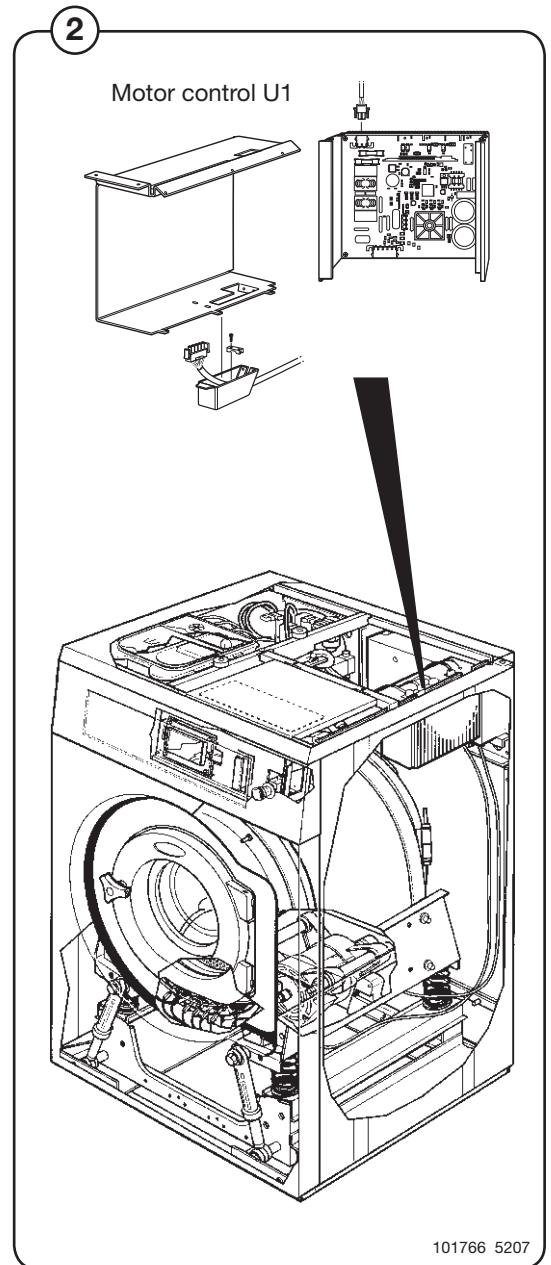

Function



DANGER



Be careful when measuring the electric components in the motor control. All components have a potential difference of approx. 300 V in relation to protective earth and neutral.

When the green LED on the motor control card is lit, the components carry dangerous voltages.

The motor control lose all voltage about 10-30 seconds after the voltage has been disconnected and the motor has stopped.

Fig.
3

The motor control communicates with the programme unit via a serial two-way interface. With the help of the motor control, the programme unit can control not only the instantaneous motor rpm, but also with high precision the acceleration and retardation of the motor in order to reach the target rpm. The motor control continuously replies with information to the programme unit PCB regarding the current operating state and sends reports if an error occurs.

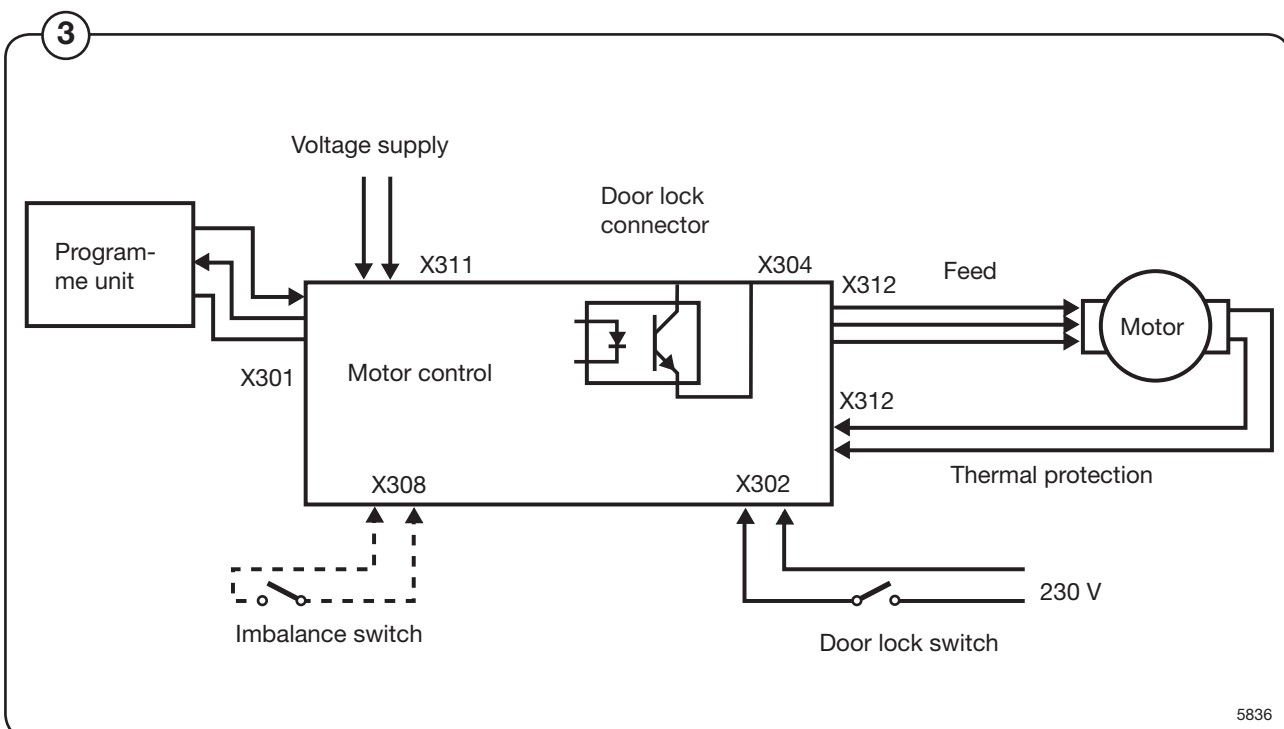

The motor control is also able to deliver various instantaneous and output values during constant speed, acceleration and retardation. These values are used to calculate the weight of the loaded laundry and to detect any load imbalances. A separate imbalance breaker can also be connected to the motor control.

The safety system of the machine includes double detection of the door lock. Both the programme unit and motor control use different switches to detect proper door locking. The motor cannot start unless both switches verify the door is locked.

Inputs and outputs

Fig. 4 **X301: Serial communication**

Handles communication between the motor control and the programme unit. Using a special interface, it is possible to connect a PC for testing the motor control.

Card No.	Function
X 301:2	Gnd
X 301:3	Txd
X 301:4	Rxd

X302: Lock sequence input

Detects when the door is locked or unlocked. The motor cannot start until the door has been locked. If the indication disappears when the motor is operating, the motor stops and an error message is shown on the programme unit display.

Input voltage		
min:	120 V-20 %	50/60 Hz
max:	240 V+15 %	50/60 Hz
Current: max:	0,01 A	

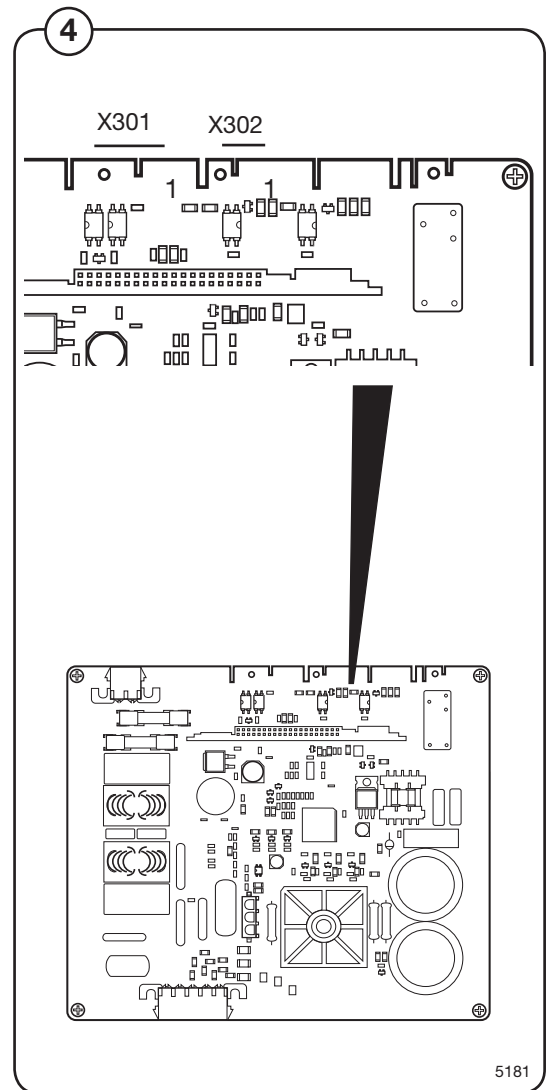

Fig.
5**X304: Door lock connector**

The collector output function is controlled from the programme unit (X301). The collector output does not switch on if there is no communication with the programme unit.

Card No.	Connection
X304:1	Common
X304:2	Not used
X304:3	Collector for output
Voltage, max	: 15 VDC
Current, max:	10 mA

X308: Imbalance switch

Input from the imbalance switch (only fitted on some machines). The imbalance switch is normal open.

Input voltage		
min:	120 V-20 %	50/60 Hz
max:	240 V+15 %	50/60 Hz
Current: max:	0,01 A	

X311: Voltage supply

Input voltage, single phase or rectified three-phase	
min:	200V-15%
max:	240V+10%

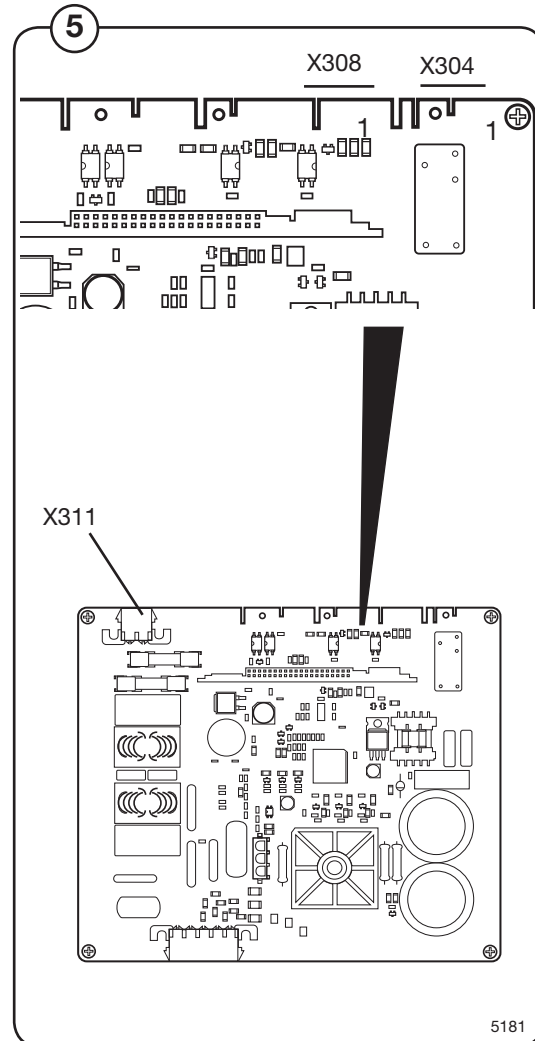

5181

Fig. 6 **X312: AC supply to motor and input from the motor thermal protector**

The motor is fed with alternating current with varying frequency that is proportional to the motor speed.

This connector also includes the input from the thermal protector of the motor.

The thermal protector switch is usually closed and triggers only in case of overheating.

W365-W3130H, Wascator FOM71 CLS

Card No.	Function
X 312:1	AC supply to motor
X 312:2	AC supply to motor
X 312:3	AC supply to motor
X 312:4	To thermal protector B41
X 312:5	To thermal protector B41

W3180-W3240H

Card No.	Function
X 312:1,2	AC supply to motor U
X 312:3,4	AC supply to motor V
X 312:5,6	AC supply to motor W
X 312:7,8	To thermal protector B41

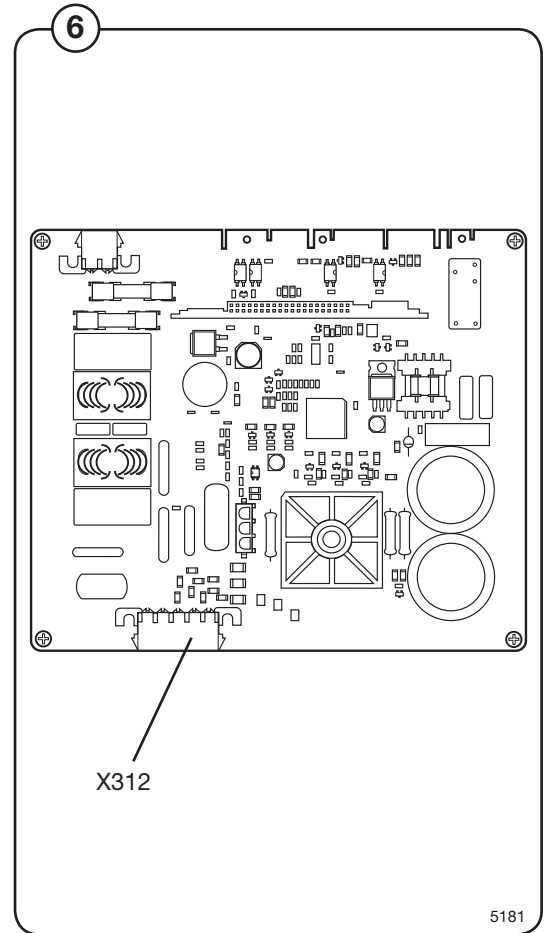

LED indications

Fig. 7 Two LEDs, one yellow and one green, indicate any errors on the motor controller and motor.

Fig. 8 The table below shows the blinking patterns of the various error codes.

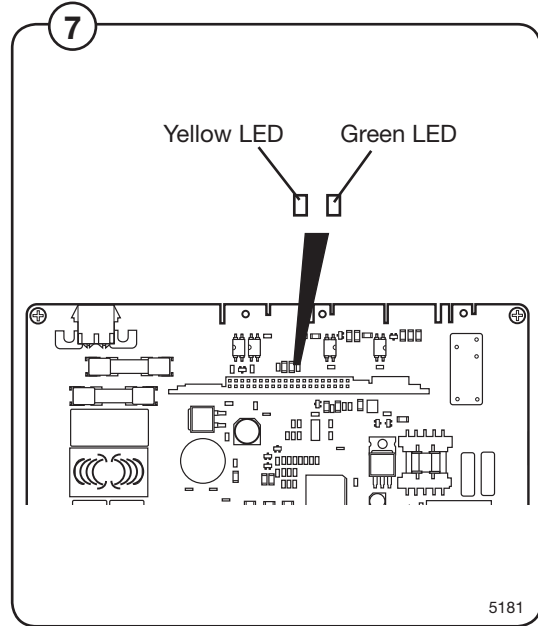

5181

8

Green LED

LED blinking pattern	Cause
	OK blink (brief pause every 5 seconds)
	Microcomputer in motor control unit not working, voltage is on.
	Current limiter of motor control has switched on.

Yellow LED

LED blinking pattern	Error code on display EXACTA CLARUS	Cause
	31E HEAT SINK TOO HOT	Overheated heat sink on motor control.
	32E MOTOR TOO HOT	Motor thermal protector has triggered.
	33E NO INTERLOCK	Motor controller receives start request, but receives no lock ACK (input 302).
	13E NO MOTOR COMM.	Communication error motor control - programme unit.
	-	Short-circuit in motor winding, harness or internally in motor control. Motor control restarts automatically.
	35E MOTOR SHORTNING	Short-circuit in motor winding, harness or internally in motor control.
	36E INTERLOCK HARDWARE	Error in lock ACK circuits in motor controller.
	37E LOW DC VOLTAGE	DC level in motor control too low.
	38E HIGH DC VOLTAGE	DC level in motor control too high.
	41E KLIXON CIRCUITS	Error in motor control circuits used to detect motor thermal protector.
	45E TACHO	Motor don't follow, error in tacho, tacho circuits, motor cable or contacts for motor cable.

Repairs

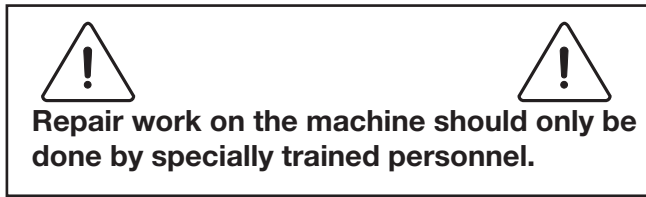

Motor replacement

Disassembly

- Fig. 9**
1. Switch off power to the machine by turning the main power switch to the 0 position.
 2. Remove the rear cover.
 3. Undo the bracket for the drain hose connector from the lower rear piece, then remove the rear cover.
- Fig. 10**
4. Undo the ground connection from the motor.
 5. Remove the drive belt by pulling the belt towards you while rotating the drum by hand.
 6. Undo the motor cable from motor.
 7. Lock the motor in place to avoid it from falling when lifting it out.
 8. Undo and remove the two motor mounting bolts.
 9. Lift out the motor.
 10. Replace the sensor and magnet from the old motor to the new one.

Assembly

1. Fit the new motor **without** locking the mounting bolts.
2. Fit the drive belt and adjust the belt tension with the tensioner on one side of the motor. See section Adjustments - Drive belt tension for details.

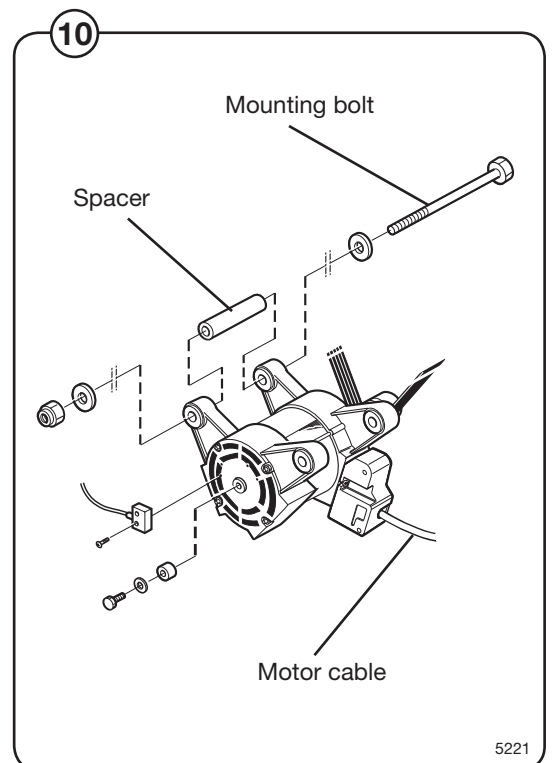
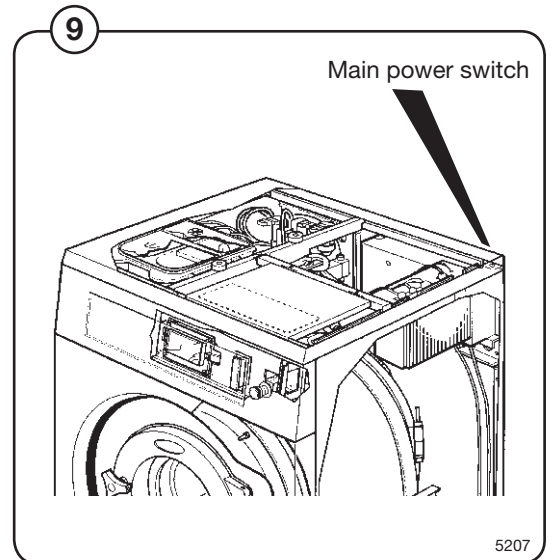

3. Connect the new motor to the motor control and use straps to secure the cable.
4. Connect the motor cable to the motor.
5. Fit the lower rear piece and secure the drain hose connection with screws.
6. Fit the upper rear piece.
7. Connect the voltage supply and verify that the motor operates normally.

Adjustments

Drive belt tension

The drive belt is pre-tensioned upon delivery from the factory.

Fig. 11 The drive belt tension should be as follows:

Model	Force A (N)	Post-tensioning B (mm)	New belt C (mm)
W365H, Wascator			
FOM71 CLS	30	9	8
W375H	30	9	8
W3105H	40	9	8
W3130H	53	10	8
W3180H	68	10	8
W3240H	75	10	8

Fig. 12 To adjust drive belt tension, first undo the motor retaining screw a couple of turns, then press down on the motor to achieve proper tensioning. Lock the locking nut when the tension is correct. Then lock the retaining screw.



Inspection of the drive belt tension is an important part of general maintenance.

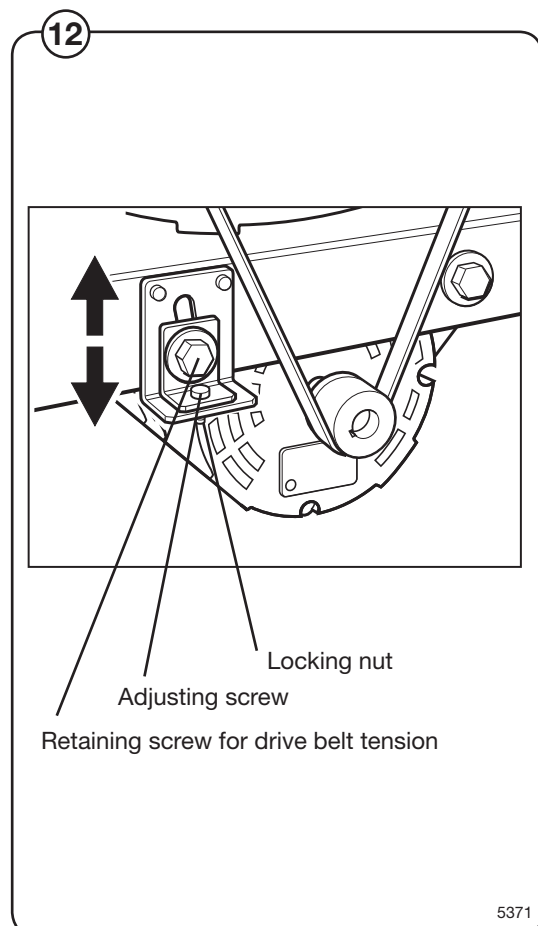
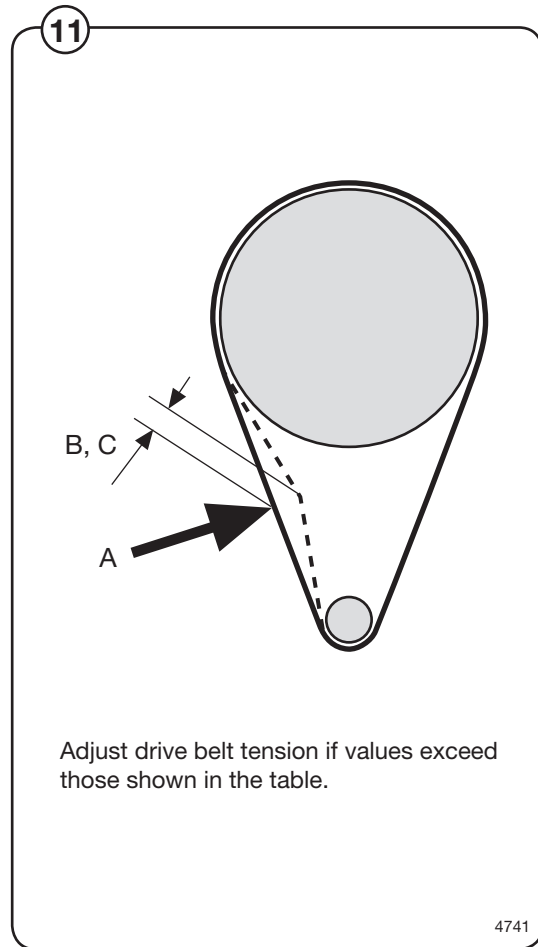

Description

W365H, W375H
from machine No. 520/22807–
and 520/19487-19548

W3105H from machine No. 595/9041–
W3130H from machine No. 650/14355–
W3180H from machine No. 725/7909–
W3240H from machine No. 795/3770–
W3300H

Motor

Fig. 13 The motor is fitted in a bridge carrier under the outer drum. It drives the washing drum using a drive belt.

The motor is frequency-controlled and is controlled by microcomputer control. The various speeds for normal operation, distribution speeds and extraction as well as acceleration/retardation can be controlled with a high degree of precision.

The motor winding is protected against overloads using a thermal overheating protector that is automatically reset.

Fig. 13 The motor is connected directly to the motor control via a cable with quick connectors.

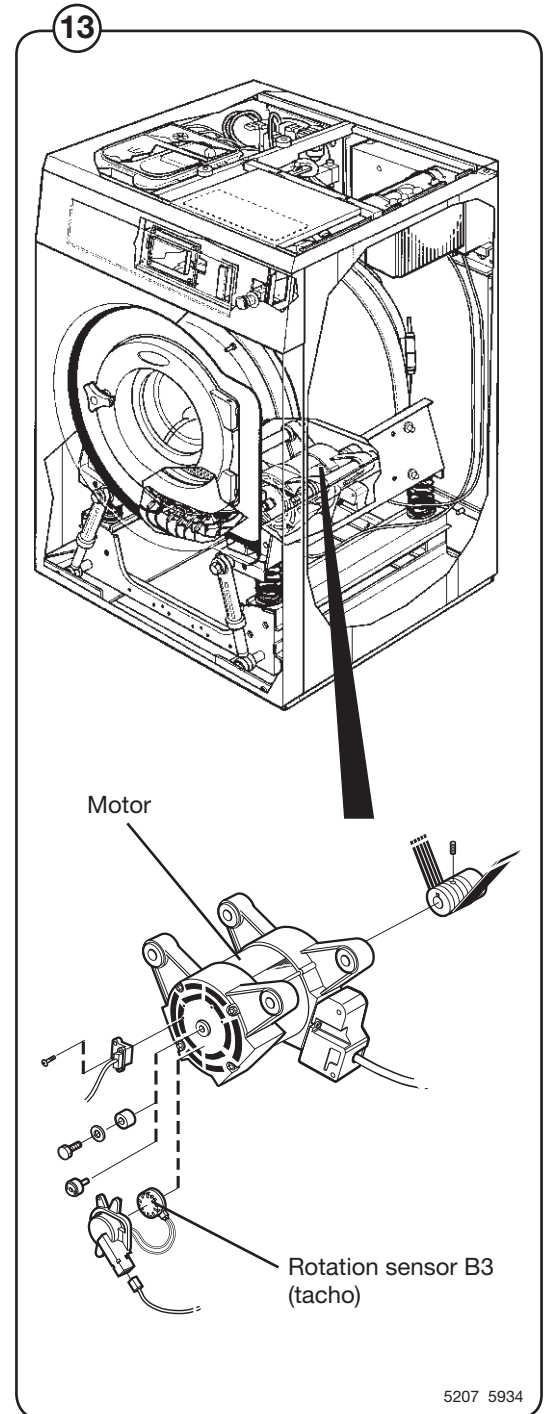

Motor control

Fig. 14 The motor control unit is microcomputer controlled and is situated under the top cover of the machine, right above the outer drum.

The unit consists of a PCB (mother board) fitted on a heat sink that does double-duty as part of the housing.

Fig. 14 The cable harness is directly connected to the PCB, voltage supply input and the voltage supply to the motor using connectors; the other cables are connected with flat connectors to the PCB.

A detailed description of input and output cables is presented in the section "Function".

Depending on the machine size, this unit comes in four different versions. The units have different sizes in order to be able to control motors of different sizes.

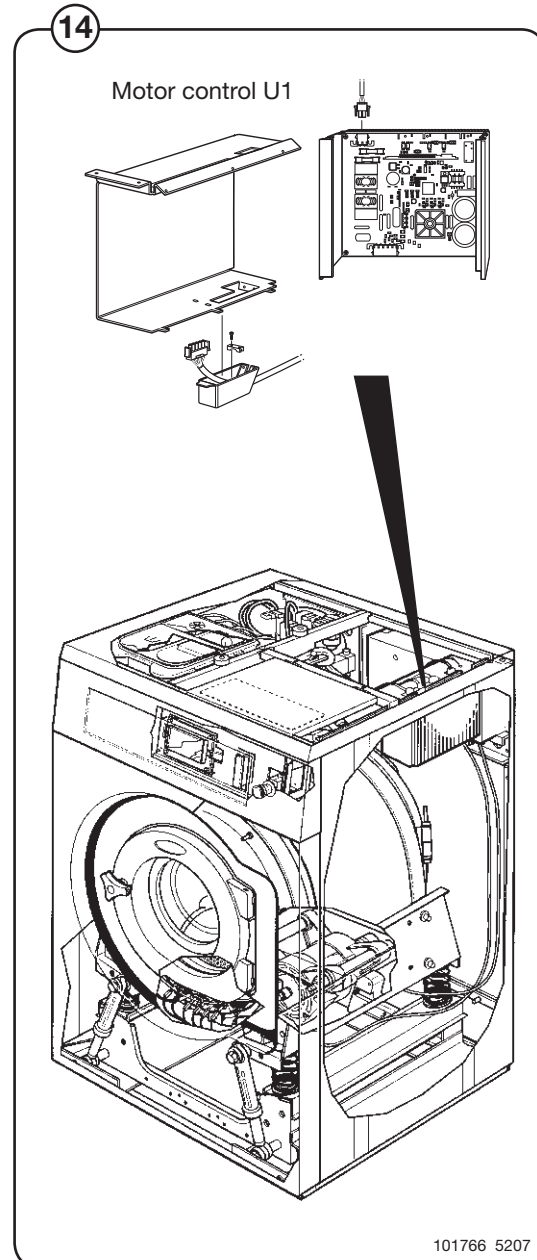

Function



DANGER



Be careful when measuring the electric components in the motor control. All components have a potential difference of approx. 300 V in relation to protective earth and neutral.

When the green LED on the motor control card is lit, the components carry dangerous voltages.

The motor control lose all voltage about 10-30 seconds after the voltage has been disconnected and the motor has stopped.

Fig. 15 The motor control communicates with the programme unit via a serial two-way interface. With the help of the motor control, the programme unit can control not only the instantaneous motor rpm, but also with high precision the acceleration and retardation of the motor in order to reach the target rpm. The motor control continuously replies with information to the programme unit PCB regarding the current operating state and sends reports if an error occurs.

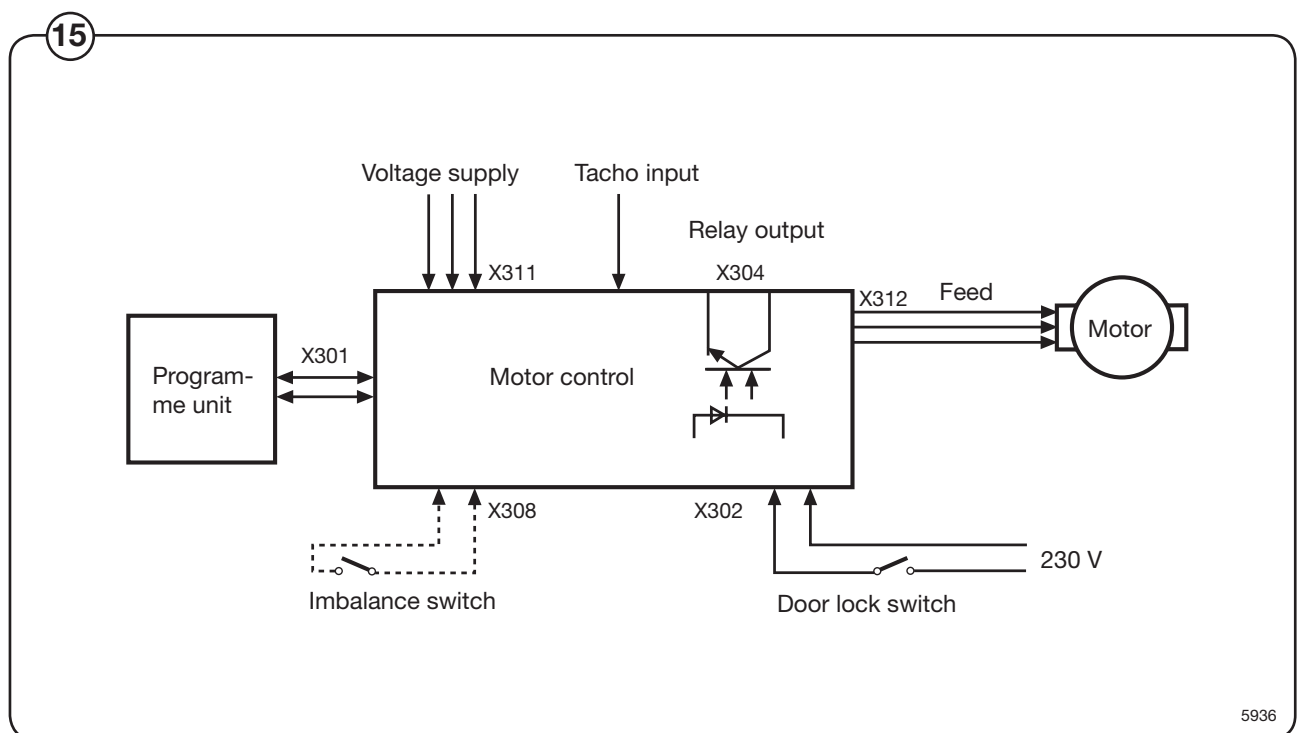

5936

The motor control is also able to deliver various instantaneous and output values during constant speed, acceleration and retardation. These values are used to calculate the weight of the loaded laundry and to detect any load imbalances. A separate imbalance breaker can also be connected to the motor control.

The safety system of the machine includes double detection of the door lock. Both the programme unit and motor control use different switches to detect proper door locking. The motor cannot start unless both switches verify the door is locked.

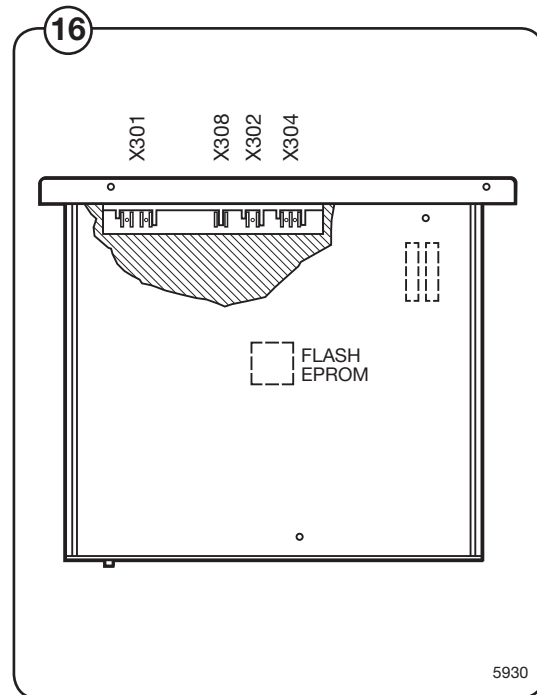

Inputs and outputs

Fig. 16 X301: Serial communication

Handles communication between the motor control and the programme unit. Using a special interface, it is possible to connect a PC for testing the motor control.

Card No.	Function
X 301:2	Gnd
X 301:3	Txd
X 301:4	Rxd

X302: Lock sequence input

Detects when the door is locked or unlocked. The motor cannot start until the door has been locked. If the indication disappears when the motor is operating, the motor stops and an error message is shown on the programme unit display.

Input voltage		
min:	120 V-20 %	50/60 Hz
max:	240 V+15 %	50/60 Hz
Current:	max:	0,01 A

Fig. 17 X304: Door lock connector

The collector output function is controlled from the programme unit (X301). The collector output does not switch on if there is no communication with the programme unit.

Tacho signal from the motor (via door lock control A31) is needed to control the motor.

Card No.	Connection
X304:1	Common, 0V
X304:2	Tacho signal
X304:3	Collector for output
Voltage, max	: 30 VDC
Current, max:	10 mA

X308: Imbalance switch

Input from the imbalance switch (only fitted on some machines). The imbalance switch is normal open.

Input voltage		
min:	120 V-20 %	50/60 Hz
max:	240 V+15 %	50/60 Hz
Current: max:	0,01 A	

X311: Voltage supply

Input voltage, single phase or rectified three-phase		
min:	200V-15%	
max:	240V+10%	

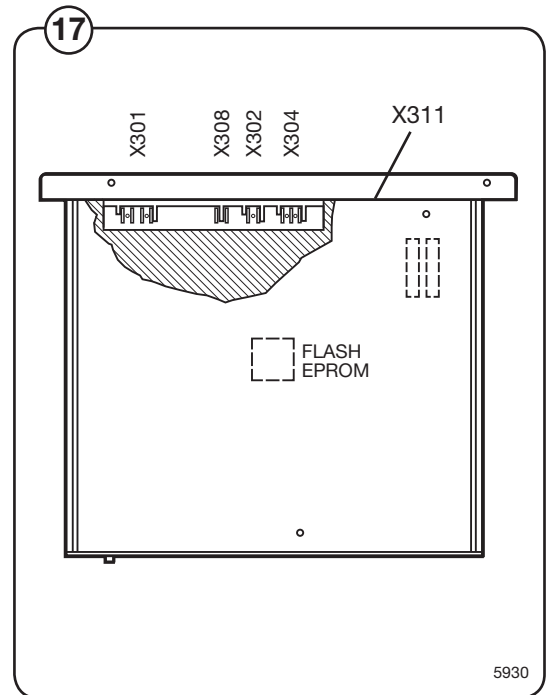

Fig. 18 **X312: AC supply to motor and input from the motor thermal protector**

The motor is fed with alternating current with varying frequency that is proportional to the motor speed.

This connector also includes the input from the thermal protector of the motor.

The thermal protector switch is usually closed and triggers only in case of overheating.

W365-W3300H,
Wascator FOM71 CLS

Card No.	Function
X 312:1	AC supply to motor
X 312:2	AC supply to motor
X 312:3	AC supply to motor

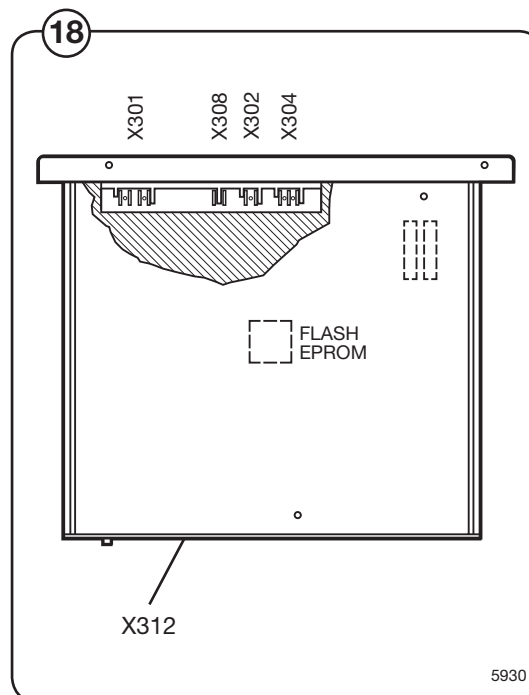

LED indications

Two LEDs, one yellow and one green, indicate any errors on the motor controller and motor.

Fig. 19 The table below shows the blinking patterns of the various error codes.

19

Green LED

LED blinking pattern	Cause
	OK blink (brief pause every 5 seconds)
	Microcomputer in motor control unit not working, voltage is on.
	Current limiter of motor control has switched on.

Yellow LED

LED blinking pattern	Error code on display	Cause
	EXACTA CLARUS	
	31E HEAT SINK TOO HOT	Overheated heat sink on motor control.
	32E MOTOR TOO HOT	Motor thermal protector has triggered.
	33E NO INTERLOCK	Motor controller receives start request, but receives no lock ACK (input 302).
	13E NO MOTOR COMM.	Communication error motor control - programme unit.
	- -	Short-circuit in motor winding, harness or internally in motor control. Motor control restarts automatically.
	35E MOTOR SHORTNING	Short-circuit in motor winding, harness or internally in motor control.
	36E INTERLOCK HARDWARE	Error in lock ACK circuits in motor controller.
	37E LOW DC VOLTAGE	DC level in motor control too low.
	38E HIGH DC VOLTAGE	DC level in motor control too high.
	41E KLIXON CIRCUITS	Error in motor control circuits used to detect motor thermal protector.
	45E TACHO	Motor don't follow, error in tacho, tacho circuits, motor cable or contacts for motor cable.

Note: A double-headed arrow labeled 'approx. 5 seconds' is shown below the last row of the Yellow LED table.

Repairs



Repair work on the machine should only be done by specially trained personnel.

Motor replacement

Disassembly

- Fig. 20**
1. Switch off power to the machine by turning the main power switch to the 0 position.
 2. Remove the rear cover.
 3. Undo the bracket for the drain hose connector from the lower rear piece, then remove the rear cover.
- Fig. 21**
4. Undo the ground connection from the motor.
 5. Remove the drive belt by pulling the belt towards you while rotating the drum by hand.
 6. Undo the motor cable from motor.
 7. Lock the motor in place to avoid it from falling when lifting it out.
 8. Undo and remove the two motor mounting bolts.
 9. Lift out the motor.
 10. Replace the sensor and magnet from the old motor to the new one.

Assembly

1. Fit the new motor **without** locking the mounting bolts.
2. Fit the drive belt and adjust the belt tension with the tensioner on one side of the motor. See section Adjustments - Drive belt tension for details.

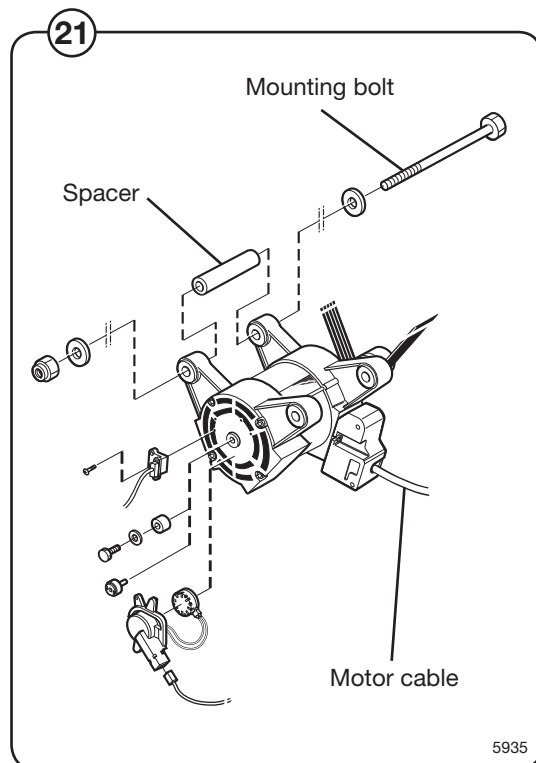
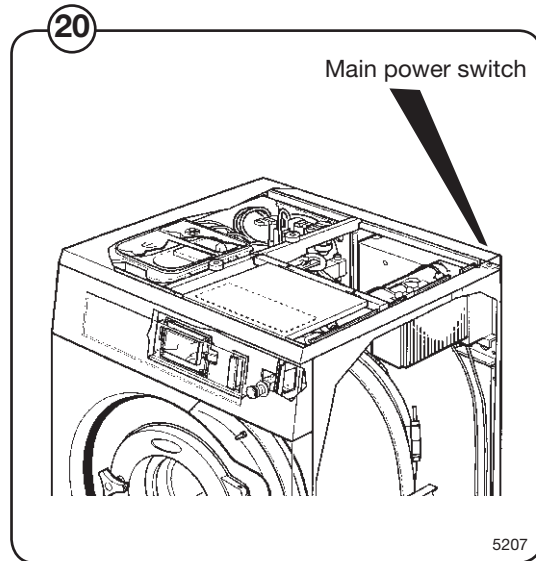

3. Connect the new motor to the motor control and use straps to secure the cable.
4. Connect the motor cable to the motor.
5. Fit the lower rear piece and secure the drain hose connection with screws.
6. Fit the upper rear piece.
7. Connect the voltage supply and verify that the motor operates normally.

Adjustments

Drive belt tension

The drive belt is pre-tensioned upon delivery from the factory.

Fig. 22 The drive belt tension should be as follows:

Model	Force A (N)	Post-tensioning B (mm)	New belt C (mm)
W365H, Wascator			
FOM71 CLS	30	9	8
W375H	30	9	8
W3105H	40	9	8
W3130H	53	10	8
W3180H	68	10	8
W3240H	75	10	8
W3300H	78	10	8

Fig. 23 To adjust drive belt tension, first undo the motor retaining screw a couple of turns, then press down on the motor to achieve proper tensioning. Lock the locking nut when the tension is correct. Then lock the retaining screw.

Inspection of the drive belt tension is an important part of general maintenance.

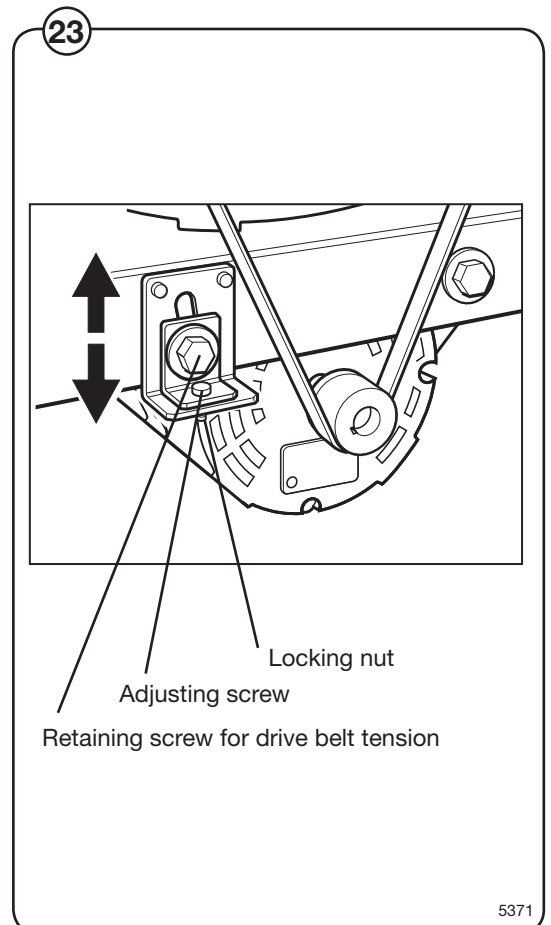
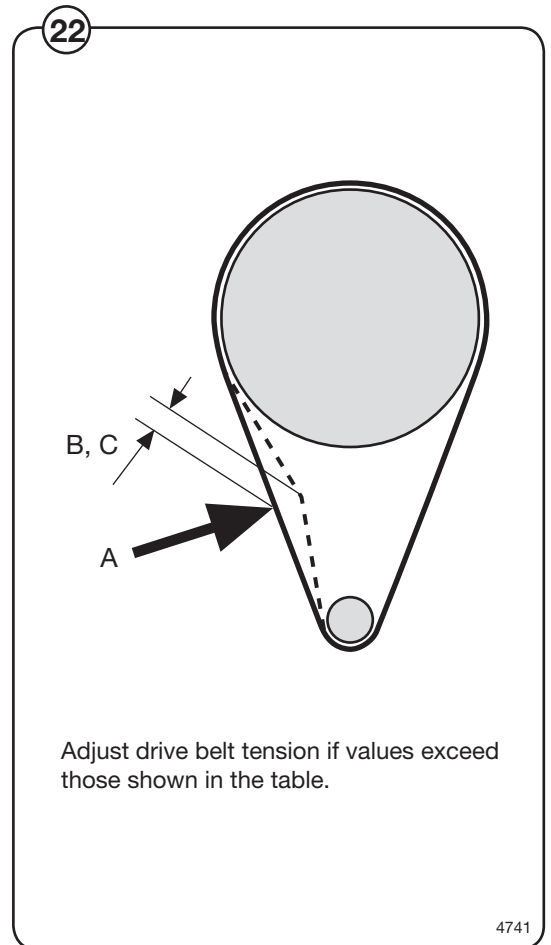

38. Drain valve

Contents

Description	3
Function	3
Repairs	4
Disassembly	4
Assembling	5

Description

Fig. 1 The drain valve is situated on a flange at the bottom of the outer drum and can be accessed from the front after removing the front cover. The drain valve consists of the following principal parts:

- Lower part with rubber diaphragm
- Piston and cylinder
- Pressure plate and recoil springs
- Rubber diaphragm with drain connection
- Upper part with connection for outer drum

Function

Fig. 2 The drain valve uses the water pressure in the cold-water inlet to close the valve. A feed hose is connected between the water inlet and the control valve.

When the control valve operates (drain valve should be closed), the control valve opens the water pressure onto the feed hose, which is connected to the lower part of the drain valve. When the lower part is filled with water, the lower part diaphragm pushes up the piston. The piston lifts the pressure plate against the drain valve rubber diaphragm, which in turn forms a seal against the outer drum, effectively closing the valve.

When the drain valve should be opened, the control valve changes position to allow the water pressure to the lower part of the drain valve to close, instead opening the return hose to the drain. The pressure plate recoil springs pull the pressure plate back, upon which the piston is pressed back into the cylinder. The water from the lower part is fed through the feed hose and the control valve to the drain.

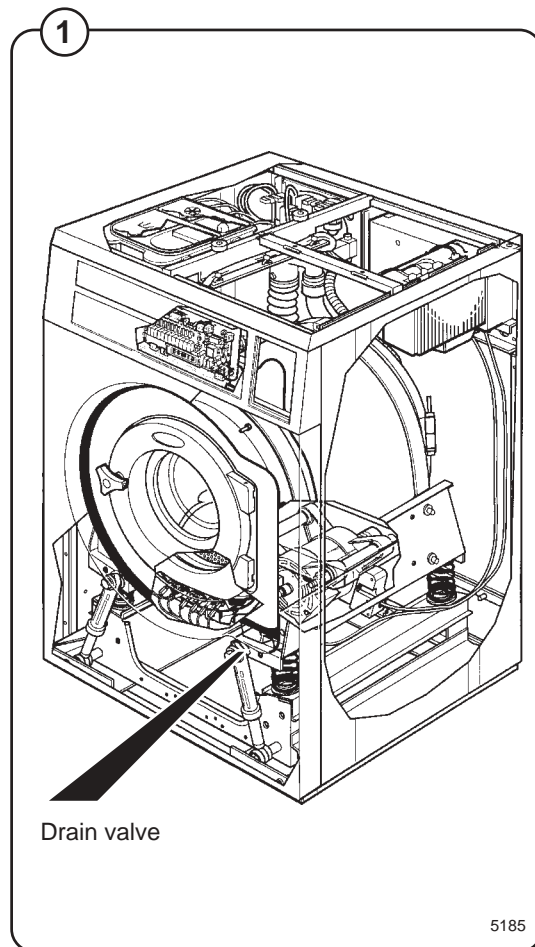

5185

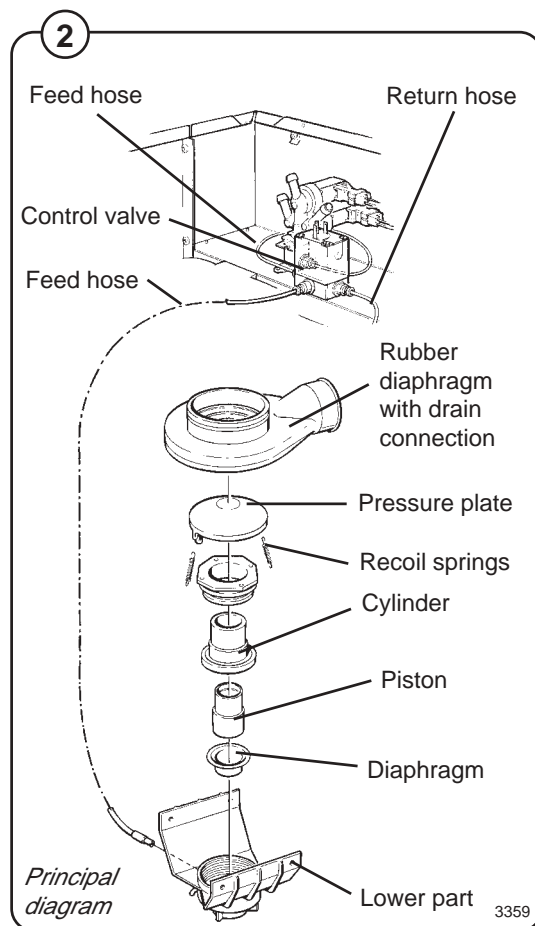

Repairs



Repair work on the machine should only be done by specially trained personnel.

Disassembly



For repair works on the drain valve, there is a risk that water still left in the machine may flood onto the floor. Be sure to dry up any spilled water since it may cause people to slip and hurt themselves.

Fig. 3 1. Take down power from the machine by turning the main power switch to the 0 position.

3 2. Remove the front cover.

Fig. 4 3. Disconnect the drain hose from upper part of the valve.

4 4. Undo the hose clamp holding the valve rubber bellows against the sleeve coupling of the outer drum.

Fig. 5 5. Loosen and unscrew the 4 retaining nuts of the valve a couple of turns (use a socket, extender and ratchet wrench). Turn the valve and unhook it from the bolts.

6. Disconnect the pressure hose from the lower part of the valve.

7. Replace the valve with a new one or replace the defective part.

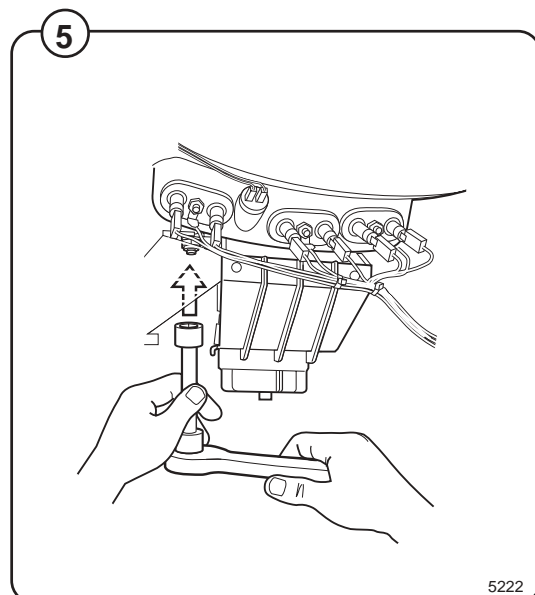
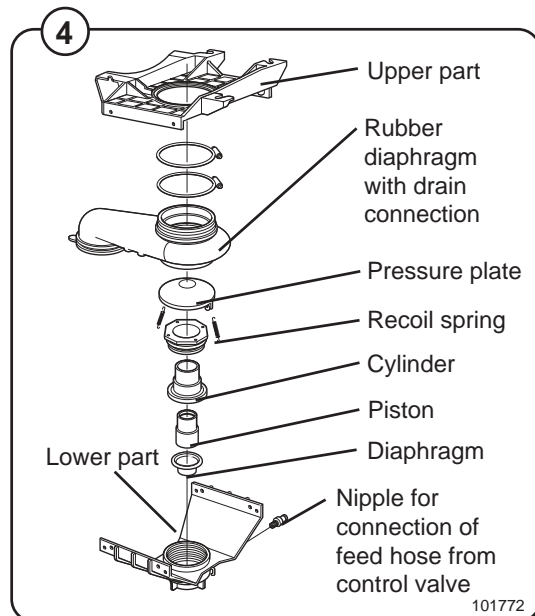
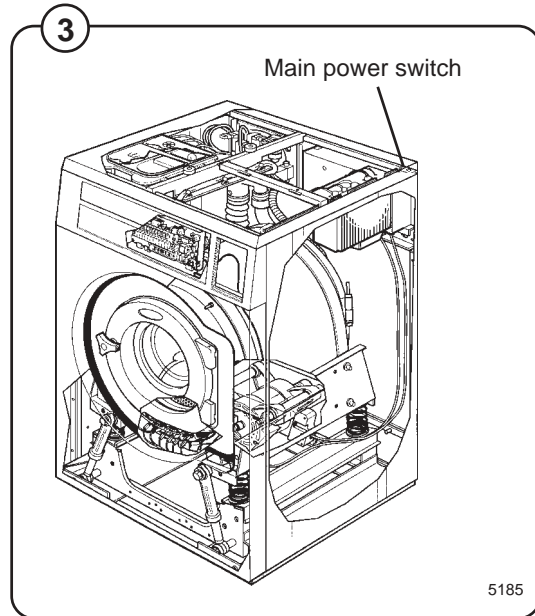

Assembling

- Fig.**
4
1. Connect the pressure hose to the lower part of the valve. Verify that the hose is not bent or pinched.
 2. Fit the rubber bellows onto the sleeve coupling.
- Fig.**
5
3. Hook the valve onto the bolts and turn the valve into position. Secure the 4 retaining bolts of the valve.
 4. Secure the hose clamp at the connection of the rubber bellows on the sleeve coupling.
 5. Connect the drain hose to the upper part of the valve.
- Fig.**
3
6. Turn the main power switch to position 1 and verify correct valve operation and that it does not leak.
 7. Reattach the front cover.

39. Detergent compartment

Contents

Description	3
-------------------	---

Description

Fig. 1 The detergent compartment of the machine is designed for use with powder and liquid detergent. The compartment is divided into four sub-compartments as follows:

- Fig. 2**
- Compartment 1 - For pre wash with powder or liquid detergent.
 - Compartment 2 - For main wash with powder detergent.
 - Compartment 3 - Rinse.
 - Compartment 4 - Main wash with liquid detergent or bleaching-agent.

The connections for incoming water are situated on the rear side of the compartment. Compartments 3 and 4 each have one connector, while compartments 1 and 2 each have two connectors, one for cold water, the other for warm water.

The detergent is routed from the bottom of the compartment to the outer drum through the combo module immediately behind the compartment.

To safeguard against overfilling, e.g., due to a blocked hose on its way to the drum, the combo module features an overflow drain directly connected to the drain of the machine.

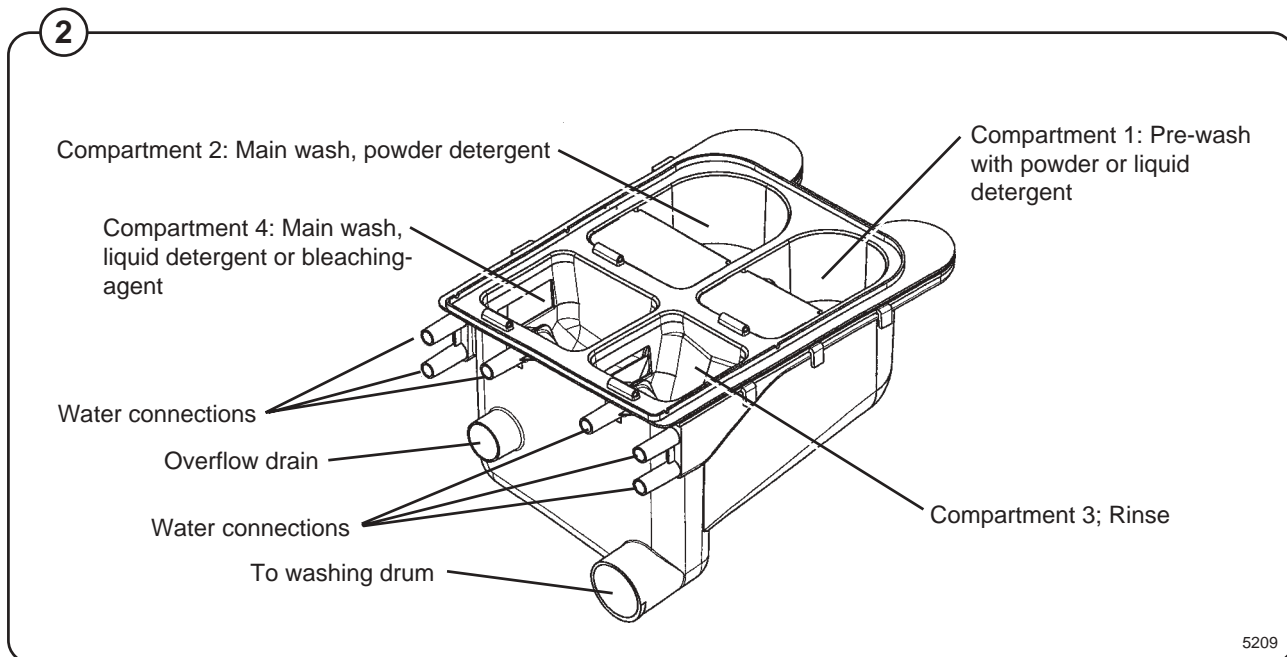
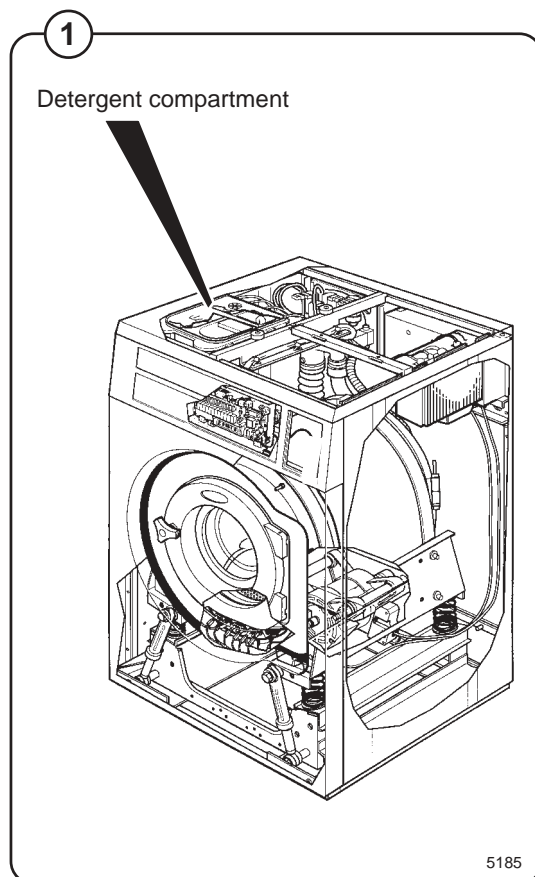

40. Heating

Contents

Description	3
Electric heating	3
Function	4
Electric heating	4
Steam heating	4
Repairs	5
Replacing the heating elements	5

Description

Electric heating

Fig. 1 The heating system of the machine consists of:

- 1 • Three heating elements for heating the water in the drum.
- A temperature sensor to detect the water temperature in the drum.
- One or two heating contactors for switch-on/ switch-off of the heating elements.

The heating elements and the temperature sensor are situated at the bottom of the outer drum close to the edge. They can be accessed front the front after the front plate is removed.

The contactor(s) is(are) placed in the rear control unit.

Depending on the size of the machine, the following heating elements are available:

Machine model	Heating element size (kW)
W365, FOM71 CLS	3x0.665, 3x1, 3x1.8, 3x2.5
W375	3x0.665, 3x1, 3x1.8, 3x2.5
W3105	3 x 2.5, 3 x 3.33, 3x1
W3130	3 x 2 x 2.165 , 3x2x0.8
W3180	3 x 2 x 3.0
W3240	3 x 2 x 3.83
W3300	3 x 7.66

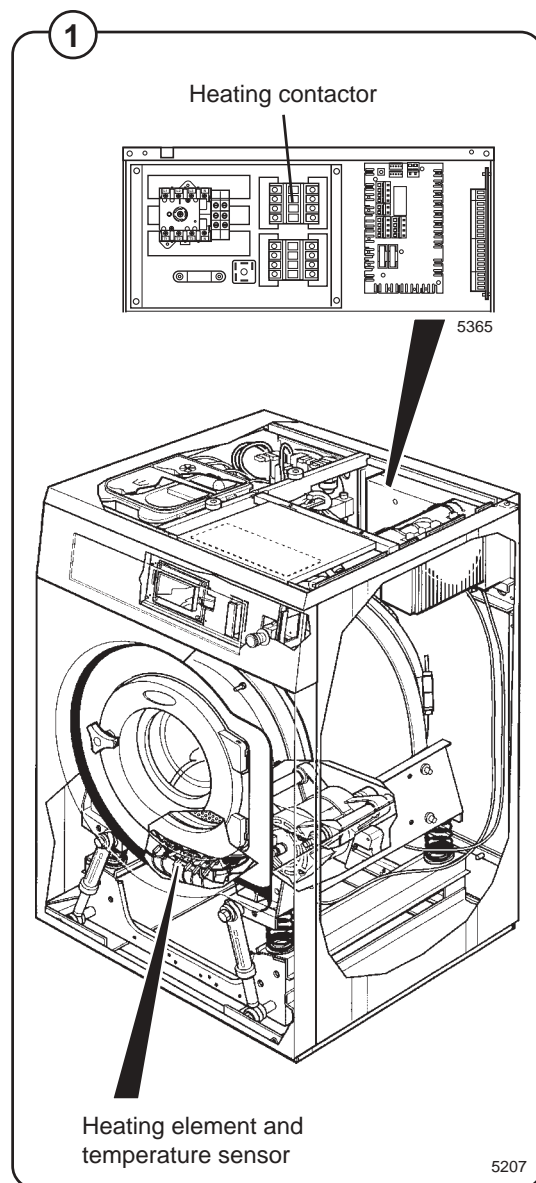

Function

Electric heating

Fig. 2 The three heating elements in the machine are connected to separate phases and are switched on and off using one or two heating contactors, K.21 and K22 (two contactors are used for higher heating power). The heating contactors are controlled by the programme unit A1 via output X8:1 on I/O card 1 A11. The control signal is fed via the communication card A21.

The programme unit receives information on the water temperature in the machine through an analogue signal from the temperature sensor situated in the outer drum. The programme unit controls the heating contactors to achieve the set water temperature for the current washing programme.

When there is no water in the drum, the programme unit prevents switch-on of the elements. If an error would nevertheless cause the elements to switch on, a slow-blow fuse triggers to switch them off again. Then the heating elements have to be exchanged.

Steam heating

Fig. 3 The steam valve is controlled by programme unit A1 via output X8:1 on I/O card 1 A11. The control signal is fed via the communication card A21.

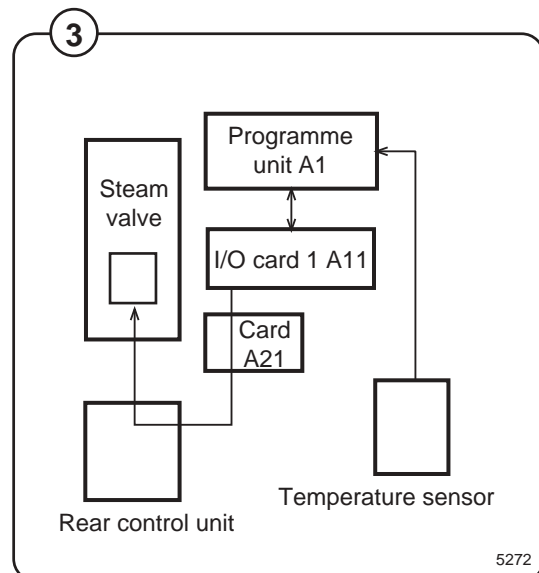
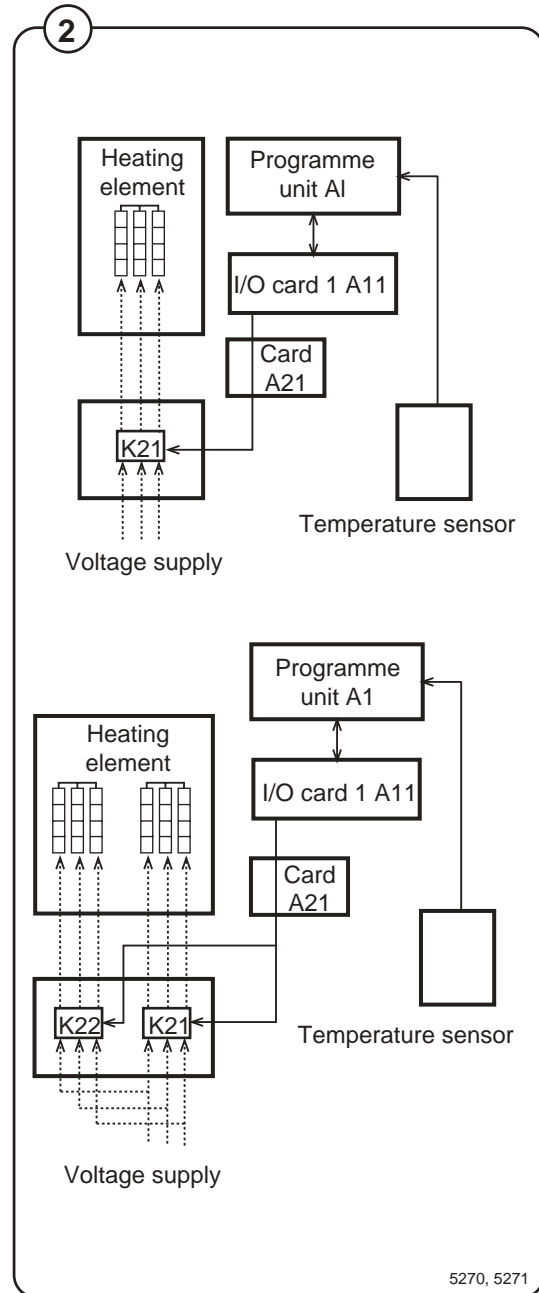

Repairs



Repair work on the machine should only be done by specially trained personnel.

Replacing the heating elements



When replacing the heating elements, there is a risk that water still left in the machine may flood onto the floor. Be sure to dry up any spilled water since it may cause people to slip and hurt themselves.

Fig. 4

1. Switch off power to the machine by turning the main power switch to the 0 position.
2. Remove the front cover.

Fig. 5

3. Make a note of how the heating elements are connected.
4. Disconnect the connection to the heating element to be replaced.
5. Unscrew the nut between the connections approx. 1 cm.
6. Push on the nut and bolt to undo the expansion bracket from the outer drum.
7. Remove the old heating element and install the new one. Be sure that the rear edge of is fitted into the element holder at the rear of the outer drum.
8. Assemble in reverse order.

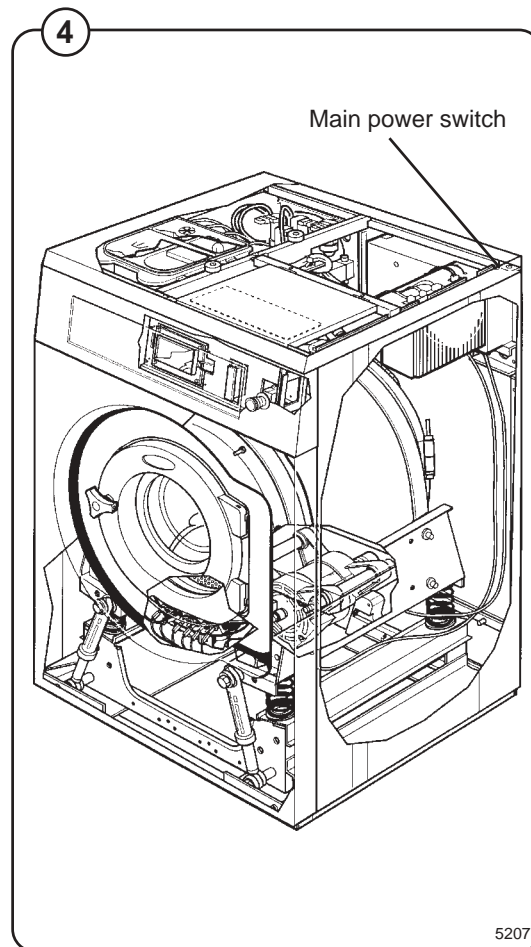

5207

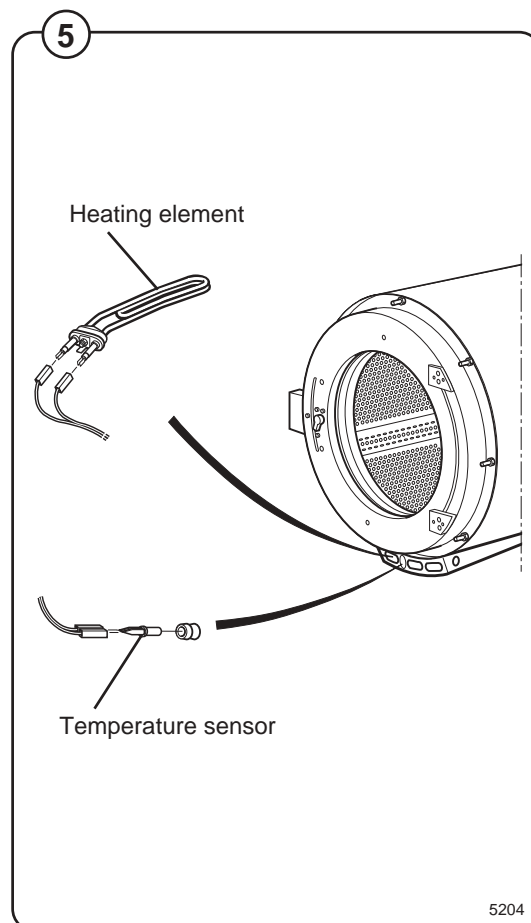

5204

43. Frame

Contents

Description	3
-------------------	---

Description

Fig. 1 The machine has a freely suspended drum assembly. The inner frame is suspended in an outer frame. The motor and drum assembly are fitted on the inner frame.

The inner frame is suspended in the outer frame by way of four coil springs. It has the shape of a cradle in which the outer drum is placed. To dampen vibrations, shock absorbers have been fitted in each corner of the machine. To improve the rigidity of the frame, two counter-weights are fitted at the front of the frame.

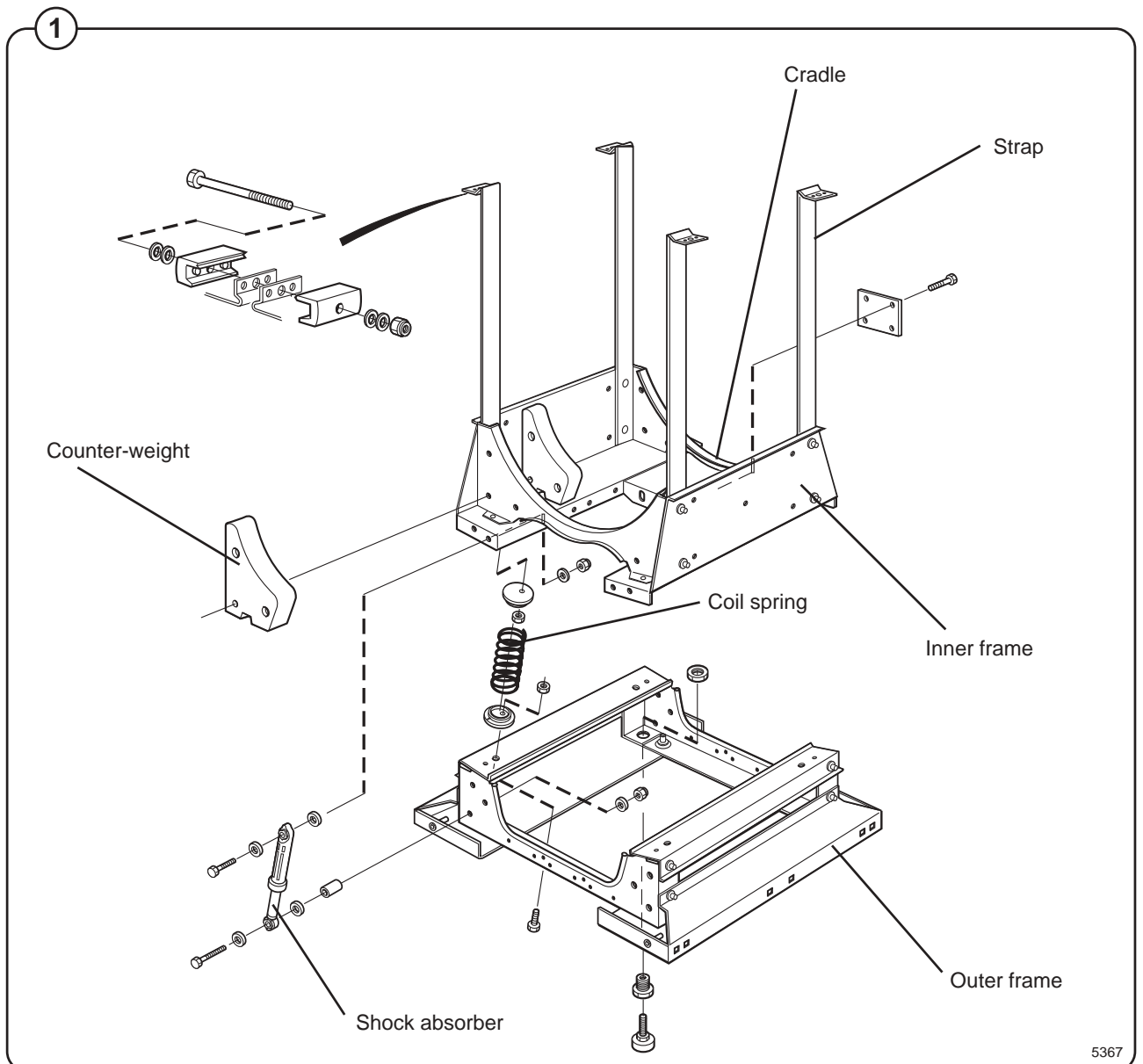

5367

50. Weighing equipment

Contents

Water level reduction	3
Actual weight display	3
Resetting the weighing equipment	3
Calibrating the weighing equipment	4
Checking accuracy of weighing equipment display	4
If the weighing equipment has a fault	4
Fault-finding, weighing equipment	5

Water level reduction

To achieve optimum load volumes, the weight of the load can be seen on the display while the machine is being loaded. If the machine does not have a full load, the water level will be reduced according to a water-level reduction table. The water level can never be any lower than the safety level plus the hysteresis.

Actual weight display

Fig. 1 The Clarus control unit automatically detects if weighing equipment is connected, and the actual (current) weight is shown on the display, on one line of the menu (normal display mode).

Fig. 2 When the machine starts to be loaded, the display switches to showing the actual weight in large numerals (weight display mode).

Normal display mode is resumed:

- If a new program number is entered using the numeric keys.
- If  is pressed.
- Automatically after the time set via "Settings 1" under "Time for weight display".

While a wash program is running, you can switch to weight display mode by selecting "Show weight", see the section "Show weight" under "Machine operation".

The weight shown on the display will always be the net weight (achieved because the weighing equipment has been "tared"). A slight delay is built in to prevent the display from flickering.

Resetting the weighing equipment

Fig. 1 If the display does not show the weight (in an empty machine) as zero after a program, the weighing equipment can be reset to zero using the TAR key.

For a description of the functions used to set and check the tare value, see the section headed "Scale adjustments" under "Machine operation".

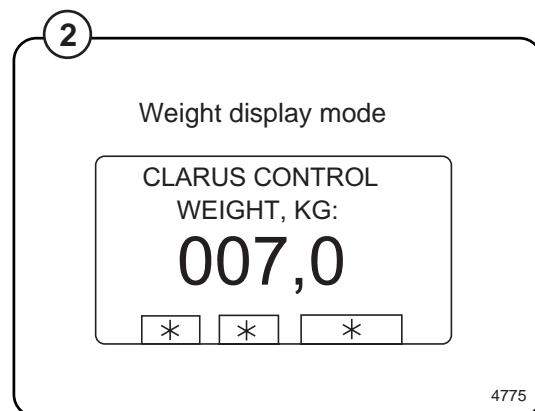
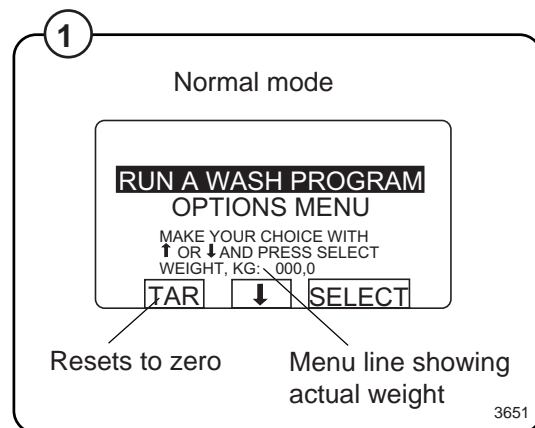

Calibrating the weighing equipment

The “Zero calibration” function is used to increase the accuracy of the weighing equipment. This should be done once a month. See the section headed “Zero calibration” under “Machine operation”.

If a new scale unit is installed, it must be calibrated as described in the section “Calibrate the scale” under “Machine operation”.

Checking accuracy of weighing equipment display

Twice a year you need to check that the weighing equipment is displaying the accurate weight, with the aid of an object of known weight. If the weighing equipment does not show the real weight of this object, you will need to follow the “Zero calibration” procedure, a function in the Clarus software. Follow the instructions under “Zero calibration” in the “Machine operation” section of the manual. If this is unsuccessful, the weighing equipment will have to be recalibrated using the “Calibrate the scale” function, as described under “Machine operation”.

If the weighing equipment has a fault

Follow the troubleshooting procedure under the heading “Fault-finding, weighing equipment”.

If you cannot rectify the problem with the help of that section, make a note of the weighing equipment version number before you contact the service department.

To find the weighing equipment version number, access the service program, select “Scale adjustments”, then “Read version number”.

Fault-finding, weighing equipment

Error message on display:

Weight, kg: 999,9 or -999,9

Probable cause:

The weighing equipment is overloaded/ "underloaded", i.e. the load cells are sending a signal which is too high/low to the scale unit. Probable cause is one or more load cells faulty. The machine may be incorrectly installed.

Fault-finding procedure:

- Check that all connections to the machine are flexible.
- If the weight displayed is -999.9, try following the "Zero calibration" procedure (described under "Zero calibration" in the "Machine operation" chapter).
- Check that the load cells are unobstructed. Remove any mechanical obstructions.
- Taking the load cell cables one at a time, disconnect the cable connecting each load cell to the scale unit. Continue one by one until a stable weight parameter is displayed (but not 999.9). When this stable parameter is displayed you will know which of the load cells must be faulty.

Fig. 44

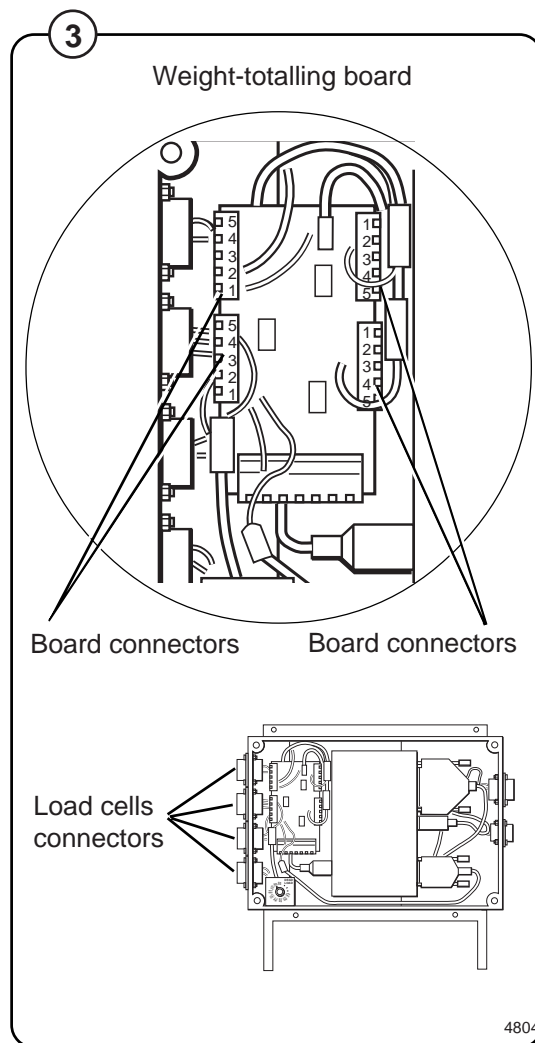

-
- If more than one load cell is faulty, the faulty cells can be identified using a multimeter on the scale unit weight-totalling board to check each cell in turn, as follows:
 - Remove the four screws on the scale unit cover.
 - Check that the four load cell cables are connected to the scale unit.
 - Measure the voltage at the connectors on the weight-totalling board, between terminal 2 and 3 for each load cell. The normal value for an unladen machine is approx. 3-5 mV (DC). A value different from this indicates that the load cell is faulty.

Menu line which should show actual weight not displayed.

Possible causes:

The option "DISPLAY WEIGHT ALLOWED" may be switched off (have the answer "No" alongside) in "Settings 1". Possible fault in communication with CPU board or display. The fault can also be in the scale unit.

Fault-finding procedure:

- Check in "Settings 1" that the option "DISPLAY WEIGHT ALLOWED" has "Yes" alongside.
- Check that the cables/wiring for CPU communication and power supply are connected to the scale unit and in good condition.
- If the washer extractor appears to be working normally apart from the absence of weight parameter display, try replacing the scale unit as described under "To replace the scale unit".

If you suspect that the weighing equipment is not displaying accurate weight value.

Probable cause:

Probably a faulty load cell.

Fault-finding procedure:

- Place an object of known weight at one corner on top of the washer extractor. Check the weight shown on the display. Move the weight to each of the other corners of the machine in turn, checking the display each time. If one corner is different from the others, this will reveal which load cell is faulty.
- Check that the load cell in question is mechanically unobstructed, free of anything which could affect its normal functioning.
- Replace the load cell as described under "To replace a load cell".

Error message on display:

Failed. Press SELECT.

Possible causes:

Calibration switch incorrectly set. An incorrect calibration weight has been used for calibration.

Fault-finding procedure:

- Fig. 4
- If you are or have recently been calibrating the weighing equipment, the calibration switch may be incorrectly set, or an incorrect calibration weight may have been used for calibration.

Check that the calibration switch is set correctly. It should normally be set to NORM. During calibration the switch should be set to CAL.

If relevant/necessary, calibrate the weighing equipment, or follow the "Calibrate the scale" procedure under "Machine operation".

- Check that all cables/wiring to the scale unit are sound and correctly connected.

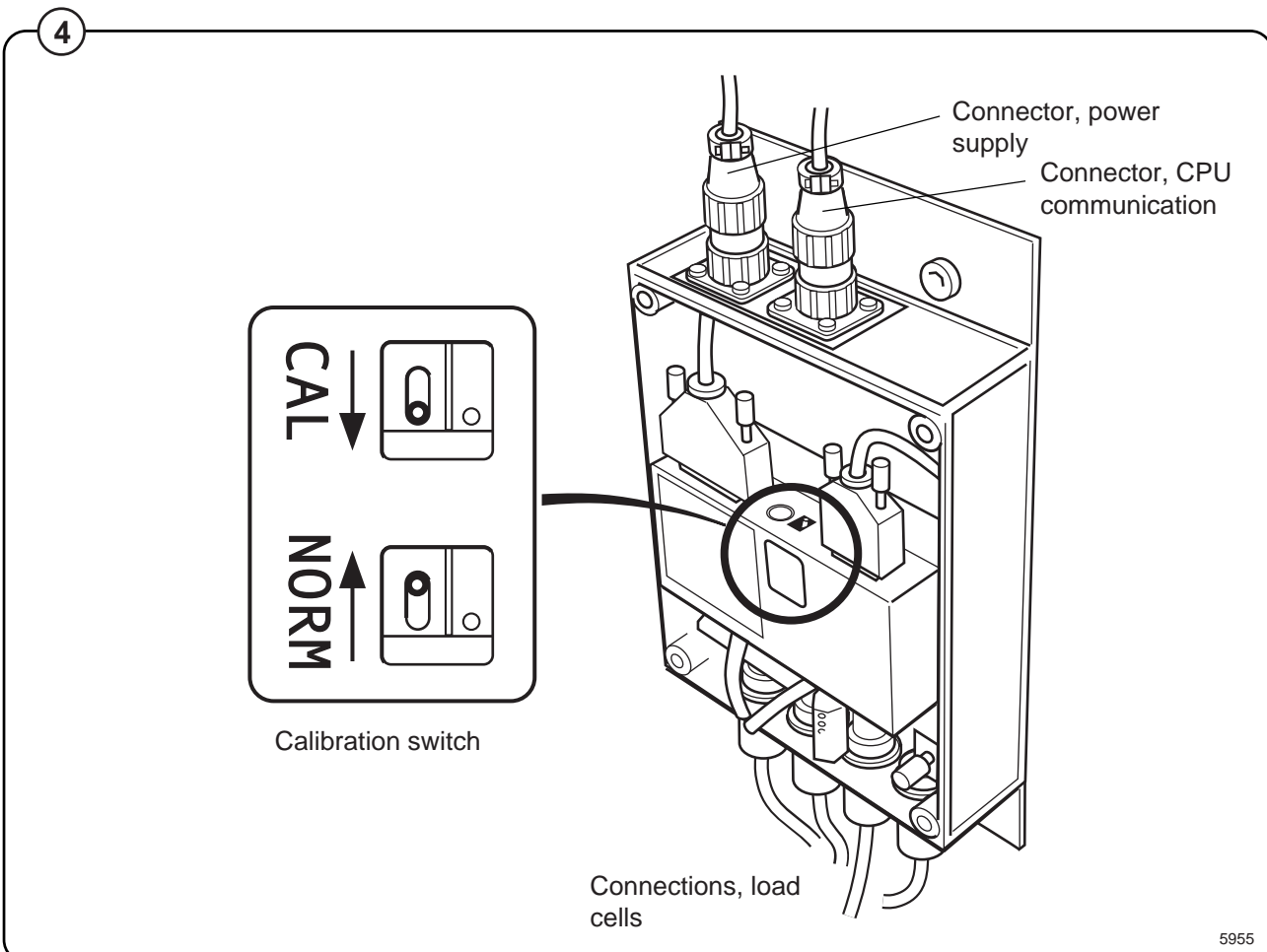

Information in display:

Function not allowed.

Probable cause:

A function has been selected in the program which cannot be carried out.

Fault-finding procedure:

- Check that the function in question is switched on under “Settings”.
- Check that the cables for CPU communication, power supply and load cells are connected.
- Check that these cables are all in good condition.
- If any cable is faulty, replace it.

Information in display in service program:

Weighing equipment not connected.

Probable cause:

CPU board not communicating with scale unit.

Fault-finding procedure:

- Check that the connectors for CPU communication, power supply and load cells are connected on the scale unit.
- Check that their cables are all in good condition.
- If any cable is faulty, replace it.



www.electrolux.com/professional

Share more of our thinking at www.electrolux.com