



# fitbit alta HR



User Manual  
Version 1.4

# Table of Contents

---

<b>Getting Started</b> .....	<b>5</b>
What's in the box .....	5
What's in this manual .....	5
<b>Set up Fitbit Alta HR</b> .....	<b>7</b>
Charge Alta HR .....	7
Set up with your phone or tablet .....	8
Set up with your Windows 10 PC .....	9
Set up with your Mac .....	10
Sync data to your Fitbit account .....	10
Wear Alta HR .....	11
Placement for all-day wear vs exercise .....	11
Wrist choice and dominant hand .....	12
Change the wristband .....	12
Remove a wristband .....	13
Attach a new wristband .....	14
<b>Basics</b> .....	<b>15</b>
Navigate Alta HR .....	15
Check battery level .....	16
Care for Alta HR .....	17
<b>Activity and Sleep</b> .....	<b>18</b>
View all-day stats .....	18
Check your heart rate .....	19
Using heart-rate zones .....	19
Default heart-rate zones .....	19
Custom heart rate zones .....	20
Track a daily activity goal .....	21
Choose a goal .....	21
See goal progress .....	21
Track your exercise .....	21
Track your hourly activity .....	22

<b>Track your sleep</b> .....	<b>23</b>
Set a sleep goal .....	23
Set a bedtime reminder .....	23
Learn about your sleep habits .....	23
<b>Set a silent alarm</b> .....	<b>24</b>
<b>Notifications</b> .....	<b>25</b>
Set up notifications .....	25
Receive calendar notifications .....	25
See incoming notifications .....	26
<b>Customization</b> .....	<b>28</b>
Change the clock face and orientation .....	28
Use Quick View .....	28
Adjust your heart rate setting .....	28
<b>Updates</b> .....	<b>29</b>
<b>Troubleshooting</b> .....	<b>30</b>
Heart-rate signal missing .....	30
Unexpected behavior .....	30
<b>General Info and Specifications</b> .....	<b>33</b>
Sensors .....	33
Materials .....	33
Wireless technology .....	33
Haptic feedback .....	33
Battery .....	33
Memory .....	34
Display .....	34
Wristband size .....	34
Environmental conditions .....	34
Learn more .....	35
Return policy and warranty .....	35
<b>Regulatory &amp; Safety Notices</b> .....	<b>36</b>
USA: Federal Communications Commission (FCC) statement .....	36

Canada: Industry Canada (IC) statement .....	37
European Union (EU) .....	38
Australia and New Zealand .....	39
China .....	39
Indonesia .....	40
Israel .....	40
Japan .....	40
Mexico .....	41
Morocco .....	41
Nigeria .....	41
Oman .....	41
Philippines .....	42
Serbia .....	42
Singapore .....	42
South Africa .....	43
South Korea .....	43
Taiwan .....	44
United Arab Emirates .....	45
Safety Statement .....	45

# Getting Started

---

Welcome to Fitbit Alta HR, the heart rate wristband that motivates you to reach your goals in style. Take a moment to review our complete safety information at <https://www.fitbit.com/safety>.

## What's in the box

Your Fitbit Alta HR box includes:



Tracker



Charging cable

The top and bottom detachable wristbands can be swapped for other colors and materials sold separately.

## What's in this manual

We'll explain how to create a Fitbit® account and make sure your tracker can transfer the data it collects to your dashboard. The dashboard is where you'll set goals, analyze historical data, identify trends, log food and water, keep up with friends, and much more. As soon as you're done setting up Alta HR, you're ready to start moving.

Next, we'll explain how to find and use the features that interest you and how to adjust your preferences. For more information, tips, and troubleshooting, browse our comprehensive help content at [help.fitbit.com](https://help.fitbit.com).

## Set up Fitbit Alta HR

---

For the best experience, use the Fitbit app for iOS, Android, or Windows 10. If you don't have a smartphone or tablet, you can also use a computer and fitbit.com instead, but keep in mind that a phone is required for call, text, and calendar notifications.

Your Fitbit account asks for information such as height, weight, and sex in order to calculate your stride length and to estimate distance, basal metabolic rate, and calorie burn. When you set up your account, your name and photos are visible to all other Fitbit users. You have the option to share other information, but most of the information you provide is private by default.

## Charge Alta HR

To charge your tracker:

1. Plug the charging cable into the USB port on your computer or a UL-certified USB wall charger.
2. Clip the other end of the charging cable to the port on the back of the tracker. The pins on the charging cable must lock securely with the port. You'll know the connection is secure when the tracker vibrates and you see a battery icon on your tracker's display. The battery icon disappears after three seconds.

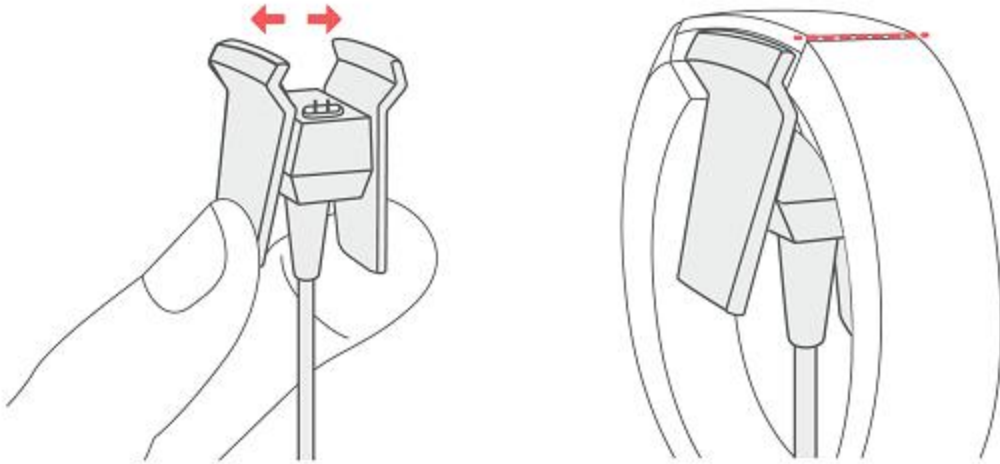

Charging fully takes about one to two hours. While the tracker charges, you can tap it to check the battery level. A fully charged tracker shows a solid battery icon.

## Set up with your phone or tablet

The free Fitbit app is compatible with more than 200 devices that support iOS, Android, and Windows 10 operating systems.

To get started:

1. Find the Fitbit app in one of the locations below, depending on your device. If you're unsure if the Fitbit app is compatible with your phone or tablet, see [fitbit.com/devices](https://www.fitbit.com/devices).
  - Apple App Store for iOS devices such as an iPhone or iPad.
  - Google Play Store for Android devices such as the Samsung Galaxy S8 and Google Pixel.
  - Microsoft Store for Windows 10 devices such as the Lumia phone or Surface tablet.
2. Install the app. If you don't have an account with the store, you must create one before you can download the app.



3. When the app is installed, open it and tap **Join Fitbit** to be guided through a series of questions that help you create your Fitbit account, or log in to your existing account.
4. Continue following the on-screen instructions to connect, or "pair," Alta HR to your phone or tablet. Pairing makes sure the tracker and phone or tablet can communicate with one another (sync data back and forth).

When you're done pairing, read through the guide to learn more about your new tracker and then explore the Fitbit dashboard.

## Set up with your Windows 10 PC

If you don't have a smartphone, you can set up and sync Alta HR using a Bluetooth-enabled Windows 10 PC and the Fitbit app.

To get the Fitbit app for your computer:

1. Click the Start button on your PC and open the Microsoft Store.
2. Search for "Fitbit app". After you find it, click **Free** to download the app to your computer.
3. If you've never downloaded an app to your computer, you'll be prompted to create an account with the Microsoft Store.
4. Click **Microsoft account** to sign in with your existing Microsoft account. If you don't already have an account with Microsoft, follow the on-screen instructions to create a new account.
5. When the app is installed, open it and click **Join Fitbit** to be guided through a series of questions that help you create your Fitbit account, or log in to your existing account.
6. Continue following the on-screen instructions to connect, or "pair," Alta HR to your computer. Pairing makes sure the tracker and computer can communicate with one another (sync data back and forth).

When you're done pairing, read through the guide to learn more about your new tracker and then explore the Fitbit dashboard.

## Set up with your Mac

If you don't have a compatible phone or tablet, you can set up your tracker with a Bluetooth-enabled Mac and use the [fitbit.com](https://www.fitbit.com) dashboard to see your stats. To use this method you'll first install a free software application called Fitbit Connect that lets Alta HR sync its data with your [fitbit.com](https://www.fitbit.com) dashboard.

To install Fitbit Connect and set up your tracker:

1. Go to [fitbit.com/setup](https://www.fitbit.com/setup).
2. Scroll down and click the option to download for Mac.
3. If prompted, save the file that appears.
4. Find and double-click the file to open the installer program (Install Fitbit Connect.pkg).
5. Click **Continue** to move through the installer
6. When prompted, choose **Set up a New Fitbit Device**.
7. Follow the on-screen instructions to create a Fitbit account, or log in to your existing account.

When you're done with the setup, Fitbit guides you through an introduction to Alta HR and takes you to the [fitbit.com](https://www.fitbit.com) dashboard.

## Sync data to your Fitbit account

Regularly sync Alta HR to transfer data to your dashboard. The dashboard is where you'll track your progress, see exercise history, track your sleep patterns, log food and water, identify trends, participate in challenges, and much more. We recommend syncing at least once a day.

The Fitbit app and Fitbit Connect use Bluetooth Low Energy technology to sync data with Alta HR.

Each time you open the Fitbit app, Alta HR syncs automatically when it's nearby. Alta HR also syncs with the app periodically if All-Day Sync is on. To turn on this feature:

From the Fitbit app dashboard, tap or click the Account icon (  ) > Alta HR tile > **All-Day Sync**.

You can also use the **Sync Now** option in the app at any time.

Fitbit Connect on your Mac syncs every 15 minutes if the tracker is within 30 feet of the computer. To force a sync, click the Fitbit Connect icon located near the date and time on your computer and choose **Sync Now**.

## Wear Alta HR

Place Alta HR around your wrist. If you need to attach a different size wristband, or if you purchased an accessory wristband, you'll find instructions in "[Change the wristband](#)" on the next page.

### Placement for all-day wear vs exercise

When you're not exercising, wear Alta HR a finger's width below your wrist bone.

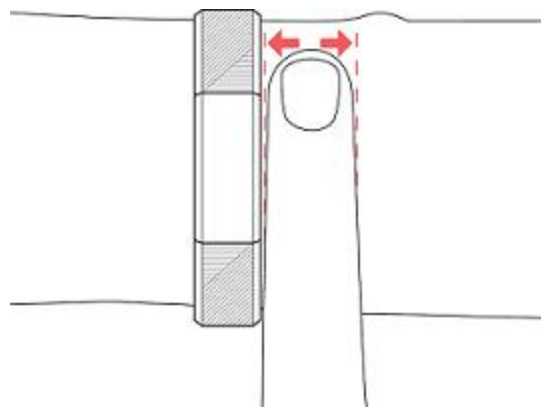

For optimized heart-rate tracking while exercising, keep these tips in mind:

- Try wearing Alta HR higher on your wrist during exercise for an improved fit and more accurate heart-rate reading. Many exercises, such as bike riding or weight lifting, cause you to bend your wrist frequently, which can interfere with the heart-rate signal if the tracker is lower on your wrist.

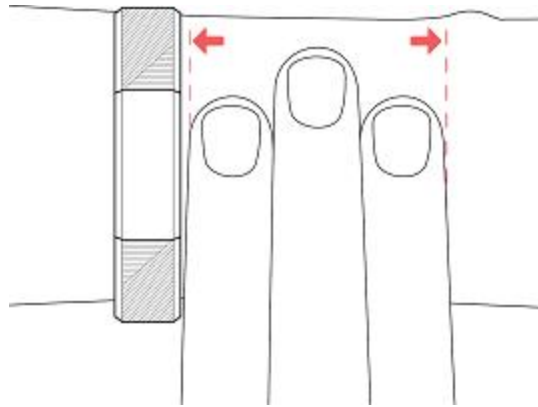

- Make sure the tracker is in contact with your skin.
- Don't wear your tracker too tight; a tight band restricts blood flow, potentially affecting the heart-rate signal. However, the tracker should be slightly tighter (snug but not constricting) during exercise than during all-day wear.
- With high-intensity interval training or other activities where your wrist is moving vigorously and non-rhythmically, the movement may limit the sensor's ability to provide a heart-rate reading. If your tracker doesn't show a heart-rate reading, try relaxing your wrist and staying still briefly (about 10 seconds). You should see a heart-rate reading.

## Wrist choice and dominant hand

For greater accuracy and ease of use, Alta HR needs to know which wrist you wear it on (right or left) and which hand you consider dominant (right or left). Your dominant hand is the one you usually write or throw with.

During setup, you're asked to choose the wrist where you're going to wear Alta HR. Should you later decide to move Alta HR to the other wrist, change the Wrist setting. You can also change your dominant hand at any time with the Handedness setting. Both settings are found in the Account section of the Fitbit app.

## Change the wristband

The wristband has two separate bands (top and bottom) that you can swap with accessory bands sold separately.

## Remove a wristband

To remove the wristband:

1. Turn Alta HR over and find the band latches—there's one on each end where the band meets the frame.
2. To release the latch, press down on the flat metal button on the strap.

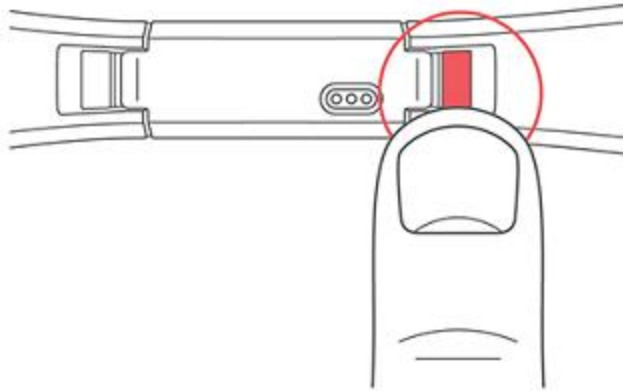

3. Slide the band up to release it from the tracker.

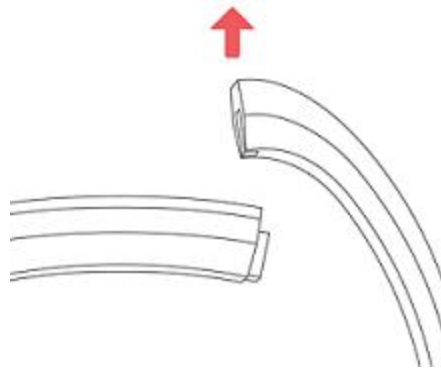

4. Repeat on the other side.

If you're having trouble removing the band or if it feels stuck, gently move the band back and forth to release it.

### Attach a new wristband

Before you attach a new wristband, first identify the top and bottom bands. The top band has a buckle on it and should be attached on the side closest to the charging port. The bottom band has notches in it.

To attach a band, slide it down on the end of the tracker until you feel it snap into place.

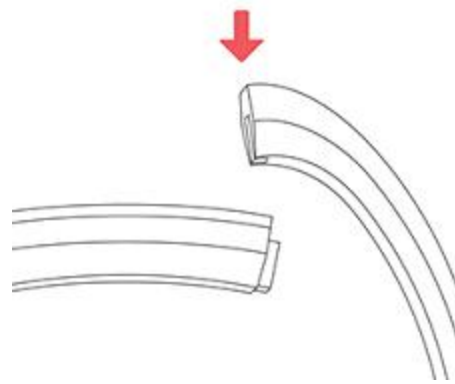

# Basics

---

Learn how best to navigate, check the battery level, and care for your tracker.

## Navigate Alta HR

Alta HR has an OLED tap display that can be oriented horizontally or vertically. You can choose from several clock faces, each with a unique design. Single-tap the display to flip through your stats.

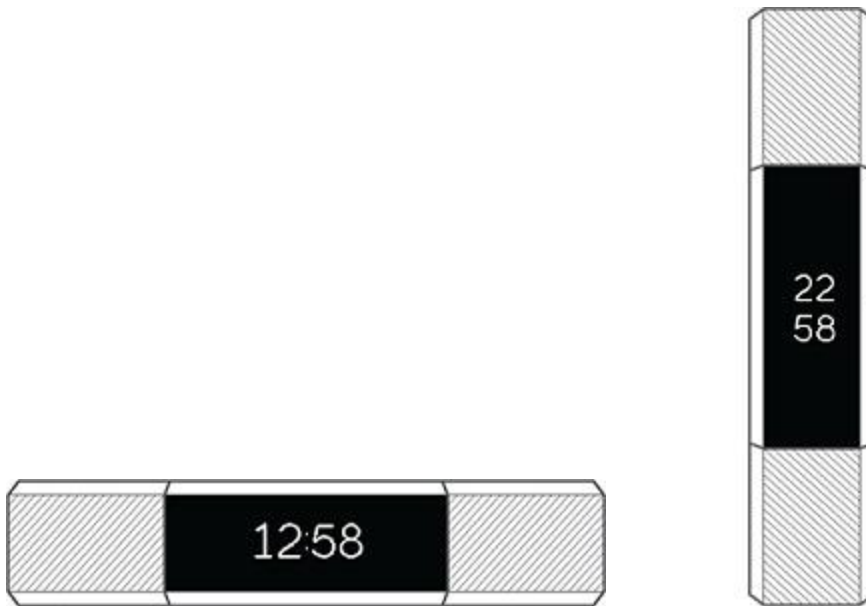

When you're not using Alta HR the display is dimmed. To wake it up:

- Double-tap your tracker.
- Turn your wrist towards you. This behavior, known as Quick View, can be turned off in your tracker settings.

For best results, tap your tracker where the screen meets the band as shown.

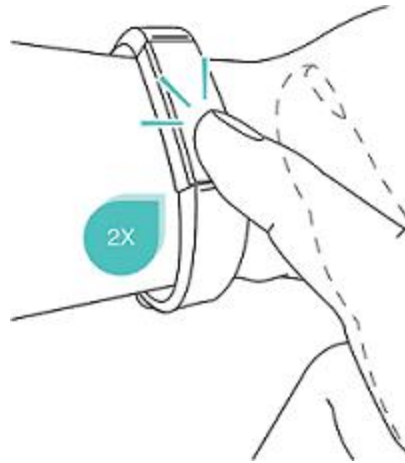

## Check battery level

Your fully charged Alta HR has a battery life of up to 7 days. Note that battery life and charge cycles vary with use, settings, and many other factors. Actual results will vary.

If your battery is low, when you wake up your Alta HR you'll see low battery icon after a few seconds. If you see a critical battery icon you'll be unable to flip through your stats until you charge your tracker. Your tracker continues to track your activity until your battery runs out. Note that heart rate tracking will stop when your battery level is at approximately 5%.



You can check your battery level at any time on the battery screen on your tracker or on your Fitbit dashboard. You must turn on the battery screen in the Fitbit app, it is not on your tracker by default.



## Care for Alta HR

It's important to clean and dry your Alta HR regularly. For instructions and more information, see [fitbit.com/productcare](https://fitbit.com/productcare).

# Activity and Sleep

Alta HR continuously tracks a variety of stats whenever you wear it. The information is transferred to your dashboard every time you sync your tracker.

## View all-day stats

Tap your Alta HR to see these all-day stats:

- Steps taken
- Current heart rate
- Resting heart rate (optional)
- Distance covered
- Calories burned
- Active minutes

Other stats captured by your tracker are available on your Fitbit dashboard, including:

- Your sleep history, including hours slept and sleep patterns
- The hours of the day that you were stationary vs. active (walked at least 250 steps)
- Your exercise history and progress towards a weekly exercise goal
- Your beats per minute (BPM), average resting heart rate, and time spent in heart-rate zones.

---

Note: Alta HR stats reset at midnight to begin a new day.

---

Double-tap your Alta HR to wake it up. When you see the clock, tap to see each of your stats in turn. If you have an alarm set, you'll also see the next alarm time.

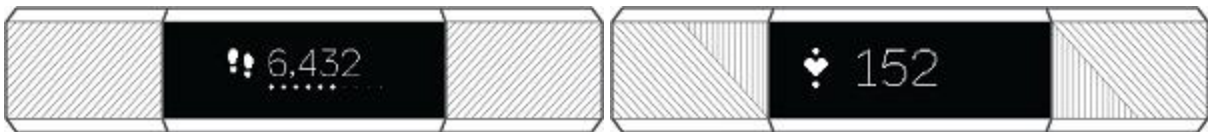

Steps

Heart rate

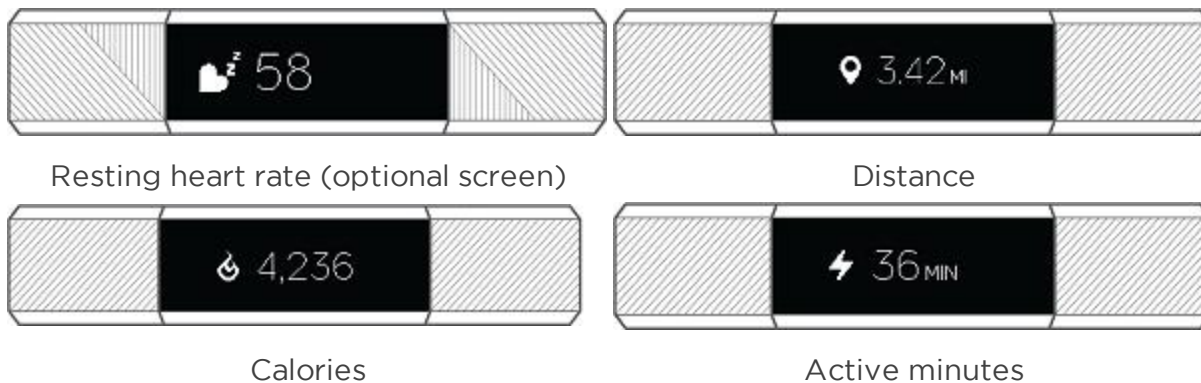

## Check your heart rate

Alta HR allows you to view your real-time heart rate and your resting heart rate on your tracker. To view your heart rate, tap your tracker until you get to the heart rate screen where you'll see your current heart rate. Tap again until you get to the resting heart rate screen to see your resting heart rate. You must turn on the resting heart rate screen in the Fitbit app.



## Using heart-rate zones

Heart-rate zones help you target the training intensity of your choice. Your tracker shows your current zone beside your heart rate, and on your Fitbit dashboard you can see your time spent in zones during a particular day or exercise. Three zones based on American Heart Association recommendations are available by default, or you can create a custom zone if you have a specific heart rate you're targeting.

## Default heart-rate zones

Default heart-rate zones are calculated using your estimated maximum heart rate. Fitbit calculates your maximum heart rate with the common formula of 220 minus your age.

Icon	Zone	Calculation	Description
♥ 64	Out of Zone	Below 50% of your	Your heart rate may be elevated, but not enough to be considered exercise.

Icon	Zone	Calculation	Description
		maximum heart rate	
 102	Fat Burn	Between 50% and 69% of your maximum heart rate	This is a low-to-medium intensity exercise zone. This zone may be a good place to start for those new to exercise. It's called the Fat Burn zone because a higher percentage of calories are burned from fat, but the total calorie burn rate is lower.
 156	Cardio	Between 70% and 84% of your maximum heart rate	This is a medium-to-high intensity exercise zone. In this zone you're pushing yourself but not straining. For most people this is the exercise zone to target.
 172	Peak	Greater than 85% of your maximum heart rate	This is a high-intensity exercise zone. This zone is for short intense sessions that improve performance and speed.

## Custom heart rate zones

Instead of using the default heart-rate zones, you can configure a custom zone or a custom max heart rate if you have a specific target in mind. For example, elite athletes might have a target that differs from the American Heart Association's recommendations for the average person. When you're in your custom zone you'll see a solid heart on your tracker. When you're not in the zone you'll see an outline of a heart.

For more details about heart rate tracking, including links to relevant American Heart Rate Association information, see [help.fitbit.com](https://help.fitbit.com).

## Track a daily activity goal

Alta HR tracks your progress towards a daily activity goal of your choice. When you reach your goal, the tracker vibrates and shows a celebration.

### Choose a goal

By default your goal is 10,000 steps per day. You can change the goal to distance traveled, calories burned, or active minutes and select the corresponding value you prefer. For example, you may want to keep steps as your goal but change the target from 10,000 to 20,000 steps.

### See goal progress

A goal progress bar helps keep you motivated. The dots in the bar shown below indicate that you're more than halfway to your goal.



## Track your exercise

The SmartTrack feature automatically detects selected exercises and records the details in your exercise history.

By default, SmartTrack detects continuous movement at least 15 minutes in length. You can increase or decrease the minimum duration or disable SmartTrack for one or more exercise types.

For more information about customizing and using SmartTrack, see [help.fitbit.com](https://help.fitbit.com).

## Track your hourly activity

Alta HR helps you stay active throughout the day by keeping track of when you're stationary and reminding you to move.

If you haven't walked at least 250 steps in a given hour, at 10 minutes before the hour you'll feel a vibration reminding you to walk. When you meet the 250-step goal after receiving the reminder, you'll feel a second vibration and see a congratulatory message.



For more information on hourly activity, including how to customize the hours you receive reminders, see [help.fitbit.com](https://help.fitbit.com).

# Track your sleep

---

Wear Alta HR to bed to automatically track your time asleep and sleep stages. To see your sleep stats, sync your tracker when you wake up and check your dashboard.

For more information about sleep tracking, see [help.fitbit.com](https://help.fitbit.com).

## Set a sleep goal

By default, you have a sleep goal of 8 hours of sleep per night. Customize this goal to meet your needs.

For more information about your sleep goal, including how to change it, see [help.fitbit.com](https://help.fitbit.com).

## Set a bedtime reminder

The Fitbit dashboard can recommend consistent bedtimes and wake times to help you improve the consistency of your sleep cycle. You can choose to be reminded nightly when it's time to start getting ready for bed.

For more information about how to set bedtime reminders, see [help.fitbit.com](https://help.fitbit.com).

## Learn about your sleep habits

Alta HR tracks several sleep metrics including when you go to bed, how long you're asleep, and your time spent in each sleep stage. When you use Alta HR with the Fitbit dashboard, your tracker can help you understand how your sleep patterns compare to others of the same sex and age range.

For more information about sleep stages, see [help.fitbit.com](https://help.fitbit.com).

## Set a silent alarm

---

Alta HR can gently vibrate to wake or alert you with a silent alarm. You can set up to eight alarms to recur every day or on particular days of the week only. When the alarm goes off, simply double tap to dismiss.

For more information about customizing and using silent alarms, see [help.fitbit.com](https://help.fitbit.com).





# Notifications

---

Over 200 different iOS, Android, and Windows phones can send call, text, and calendar notifications to your tracker. Keep in mind the phone and tracker must be within 30 feet of each other to receive notifications. To check whether your phone is compatible with this feature, go to <https://www.fitbit.com/devices>.

## Set up notifications

Check that Bluetooth on your phone is on and that your phone can receive notifications (often under Settings > Notifications). Then follow the steps below to set up notifications:

1. With your tracker nearby, from the Fitbit app dashboard, tap the Account icon (  ) > Alta HR tile.
2. Tap **Notifications**. When you're prompted to pair Alta HR, follow the on-screen instructions. After you've paired your tracker, "Alta HR" will appear in the list of Bluetooth devices connected to your phone. Call, text, and calendar notifications are turned on automatically.
3. Tap **Notifications** > **Alta HR** in the top left corner to return to device settings. Your tracker syncs to complete the setup.

For detailed instructions on how to set up notifications, see [help.fitbit.com](http://help.fitbit.com).

## Receive calendar notifications

Your tracker will show calendar events and any information sent from your calendar app to your phone. Note that if your calendar app does not send notifications to your phone, you won't receive notifications on your tracker.



If you have an iOS or Windows 10 phone, your Alta HR shows notifications from all calendars synced to the default Calendar app. If you have a third-party calendar app that is not synced to your default app, you won't see notifications from that app.

If you have an Android device, your Alta HR shows calendar notifications from the calendar app you choose during setup. You can choose from the default Calendar app on your phone or several third-party calendar apps.

## See incoming notifications

If your tracker and phone are within 30 feet of each other, a call, text message, or calendar event causes the tracker to vibrate and the notification to appear on the tracker's display. If the display is off, turn your wrist towards you or double-tap to wake it up. The notification is only visible for one minute. If you have more than one unread notification, you'll see a plus sign (+) indicator.

For phone calls, the notification scrolls three times with the name or number of the caller.



For text messages and calendar events, the notification scrolls once.



For calendar events, the event time scrolls, followed by the name of the event.



The character limit for notifications is 40. Note that all notifications are shown horizontally, even if your clock orientation is normally vertical.

# Customization

---

This section explains how to adjust the tracker's display and modify certain behaviors.

## Change the clock face and orientation

Alta HR has several clock faces available in horizontal and vertical styles.

Change the clock face using the Fitbit app. For more information, see [help.fitbit.com](https://help.fitbit.com).

## Use Quick View

To preserve battery, your tracker's screen turns off when not in use. It wakes up automatically when you turn your wrist towards you (known as Quick View), or you can wake it up by double tapping your tracker.

For more information about turning Quick View on or off, see [help.fitbit.com](https://help.fitbit.com).

Note that Quick View works best when wearing the tracker properly as described in "Wear Alta HR" on page 11.

## Adjust your heart rate setting

Your Alta HR uses PurePulse technology to track heart rate automatically and continuously. The Heart Rate setting has three options:

- Auto (the default)—Heart rate tracking is active when you're wearing your tracker.
- Off—Heart rate tracking is off.
- On—Heart rate tracking is on regardless of whether you're wearing your tracker.

For more information about adjusting the heart rate tracker, see [help.fitbit.com](https://help.fitbit.com).

# Updates

---

We occasionally make free feature enhancements and product improvements available through firmware updates. We recommend keeping your Alta HR up to date.

When a firmware update is available you'll see a notification in the Fitbit app prompting you to update. When the update starts, a progress bar appears on the tracker and in the Fitbit app until the update is complete.

Keep your tracker and phone close to each other during the update process.

---

Note that updating your Alta HR takes several minutes and may be demanding on the battery. For this reason, we recommend plugging your tracker into the charging cable before updating.

---

# Troubleshooting

---

If your tracker is not working properly, review our troubleshooting guidance below. Visit [help.fitbit.com](https://help.fitbit.com) for more information.

## Heart-rate signal missing

Alta HR continuously tracks your heart rate while you're exercising and throughout the day. Occasionally, the heart-rate sensor on your tracker may have difficulty finding a good signal. When this happens, you'll see dashed lines where your current heart rate usually appears.



If you're not getting a heart-rate signal, first make sure you're wearing your tracker correctly, either by moving it higher or lower on your wrist or by tightening or loosening the band. Alta HR should be in contact with your skin. After holding your arm still and straight for a short time, you should see your heart rate again.

If the heart rate signal is still missing, check your Heart Rate setting on your Fitbit dashboard and make sure it's set to On or Auto.

## Unexpected behavior

If you experience one of the following problems, it may be fixed by restarting your tracker:

- Not syncing despite successful setup
- Not responding to taps despite being charged
- Not tracking your steps or other data

---

Note: Restarting your tracker reboots the device but does not delete any data.

---

To restart your tracker:

1. Plug the charging cable into the USB port on your computer or a UL-certified USB wall charger.
2. Clip the other end of the charging cable to the port on the back of the tracker. The pins on the charging cable must lock securely with the port. You'll know the connection is secure when the tracker vibrates and you see a battery icon on your tracker's display. The battery icon disappears after three seconds.

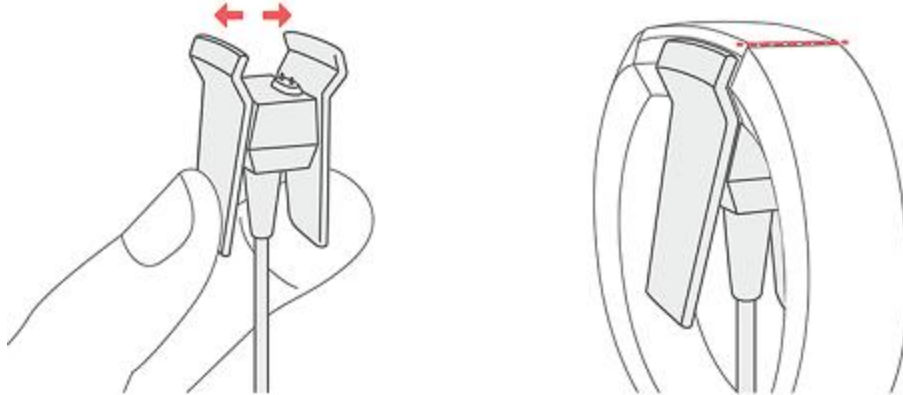

3. Press the button on your charging cable 3 times within 8 seconds, briefly pausing between presses. The button is on the end of the charging cable that is plugged into the computer.

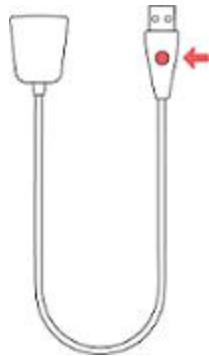

When you see the Fitbit logo and the tracker vibrates, this means the tracker has restarted.

After your tracker restarts you can unplug it from the charging cable and put it back on. For additional troubleshooting or to contact Customer Support, see [help.fitbit.com](https://help.fitbit.com).



# General Info and Specifications

---

## Sensors

Fitbit Alta HR contains the following sensors and motors:

- A MEMS 3-axis accelerometer, which tracks motion patterns
- An optical heart rate tracker

## Materials

The wristband that comes with Alta HR is made of a flexible, durable elastomer material similar to that used in many sports watches. It does not contain latex. Accessory wristbands are available in genuine leather.

The clasp and housing on Alta HR are made of surgical-grade stainless steel. While all stainless steel contains traces of nickel and can cause an allergic reaction in someone with nickel sensitivity, the amount of nickel in all Fitbit products meets the European Union's stringent Nickel Directive.

## Wireless technology

Alta HR contains a Bluetooth 4.0 radio transceiver.

## Haptic feedback

Alta HR contains a vibration motor for alarms, goals, notifications, and reminders.

## Battery

Alta HR contains a rechargeable lithium-polymer battery.

## Memory

Refer to the following table for information on how long Alta HR stores stats and data in between the times when it syncs. Stored data consists of steps, distance, calories burned, active minutes, heart rate, sleep, and stationary vs. active hours.

We recommend syncing Alta HR at least once a day.

Type of data	Days stored
Minute-by-minute stats	7
Sleep data	7
Sleep stages	5
SmartTrack data	7
Summary totals	30

## Display

Alta HR has an OLED tap display.

## Wristband size

Wristband sizes are shown below. Note that accessory wristbands sold separately may vary slightly.

Small wristband	Fits a wrist between 5.5 and 6.7 inches in circumference
Large wristband	Fits a wrist between 6.7 and 8.1 inches in circumference
Extra large wristband	Fits a wrist between 8.1 and 9.3 inches in circumference

## Environmental conditions

Operating Temperature	14° to 113° F (-10° to 45° C)
Non-operating Temperature	-4° to 14° F (-20° to -10° C)

	113° to 140°F (45° to 60° C)
Water Resistance	Splash proof.
Maximum Operating Altitude	30,000 feet (9,144 m)

## Learn more

To learn more about your tracker and dashboard, visit [help.fitbit.com](https://help.fitbit.com).

## Return policy and warranty

Warranty information and the fitbit.com return policy can be found at [fitbit.com/legal/returns-and-warranty](https://fitbit.com/legal/returns-and-warranty).

# Regulatory & Safety Notices

---

Model Name: FB408

## USA: Federal Communications Commission (FCC) statement

Notice to the User: The FCC and Industry Canada IDs can also be viewed on your device. To view content:

- While your tracker is charging, press the button on the charging cable six times to see the Regulatory screen.

This device complies with Part 15 of the FCC Rules.

Operation is subject to the following two conditions:

1. This device may not cause harmful interference and
2. This device must accept any interference, including interference that may cause undesired operation of the device.

### FCC Warning

Changes or modifications not expressly approved by the party responsible for compliance could void the user's authority to operate the equipment.

Note: This equipment has been tested and found to comply with the limits for a Class B digital device, pursuant to part 15 of the FCC Rules. These limits are designed to provide reasonable protection against harmful interference in a residential installation. This equipment generates, uses and can radiate radio frequency energy and, if not installed and used in accordance with the instructions, may cause harmful interference to radio communications. However, there is no guarantee that interference will not occur in a particular installation. If this equipment does cause harmful interference to radio or television reception, which can be determined by turning the equipment off and on, the user is encouraged to try to correct the interference by one or more of the following measures:

- Reorient or relocate the receiving antenna.
- Increase the separation between the equipment and receiver.
- Connect the equipment into an outlet on a circuit different from that to which the receiver is connected.
- Consult the dealer or an experienced radio/TV technician for help.

This device meets the FCC and IC requirements for RF exposure in public or uncontrolled environments.

FCC ID: XRAFB408

## Canada: Industry Canada (IC) statement

This device meets the IC requirements for RF exposure in public or uncontrolled environments.

Cet appareil est conforme aux conditions de la IC en matière de RF dans des environnements publics ou incontrôlée

IC Notice to Users English/French in accordance with current issue of RSS GEN:

This device complies with Industry Canada license exempt RSS standard(s).

Operation is subject to the following two conditions:

1. this device may not cause interference, and
2. this device must accept any interference, including interference that may cause undesired operation of the device.

Cet appareil est conforme avec Industrie Canada RSS standard exempts de licence (s). Son utilisation est soumise à Les deux conditions suivantes:

1. cet appareil ne peut pas provoquer d'interférences et
2. cet appareil doit accepter Toute interférence, y compris les interférences qui peuvent causer un mauvais fonctionnement du dispositif

IC ID: 8542A-FB408

## European Union (EU)

### **Simplified EU Declaration of Conformity**

Hereby, Fitbit, Inc. declares that the radio equipment type Model FB408 is in compliance with Directive 2014/53/EU. The full text of the EU declaration of conformity is available at the following internet address: [www.fitbit.com/safety](http://www.fitbit.com/safety)

### **Vereinfachte EU-Konformitätserklärung**

Fitbit, Inc. erklärt hiermit, dass die Funkgerätypen Modell FB408 die Richtlinie 2014/53/EU erfüllen. Der vollständige Wortlaut der EU-Konformitätserklärungen kann unter folgender Internetadresse abgerufen werden: [www.fitbit.com/safety](http://www.fitbit.com/safety)

### **Declaración UE de Conformidad simplificada**

Por la presente, Fitbit, Inc. declara que el tipo de dispositivo de radio Modelo FB408 cumple con la Directiva 2014/53/UE. El texto completo de la declaración de conformidad de la UE está disponible en la siguiente dirección de Internet: [www.fitbit.com/safety](http://www.fitbit.com/safety)

### **Déclaration UE de conformité simplifiée**

Fitbit, Inc. déclare par la présente que les modèles d'appareils radio FB408 sont conformes à la Directive 2014/53/UE. Les déclarations UE de conformité sont disponibles dans leur intégralité sur le site suivant : [www.fitbit.com/safety](http://www.fitbit.com/safety)

### **Dichiarazione di conformità UE semplificata**

Fitbit, Inc. dichiara che il tipo di apparecchiatura radio Modello FB408 è conforme alla Direttiva 2014/53/UE. Il testo completo della dichiarazione di conformità UE è disponibile al seguente indirizzo Internet: [www.fitbit.com/safety](http://www.fitbit.com/safety)



## Australia and New Zealand

Notice to the User: Regulatory content for this region can also be viewed on your device. To view content:

- While your tracker is charging, press the button on the charging cable six times to see the Regulatory screen.



## China

Notice to the User: Regulatory content for this region can also be viewed on your device. To view content:

- While your tracker is charging, press the button on the charging cable six times to see the Regulatory screen.



部件名称	有毒和危险品					
	铅 (Pb)	水银 (Hg)	镉 (Cd)	六价铬 (Cr(VI))	多溴化苯 (PBB)	多溴化二苯 醚 (PBDE)
Alta HR Model FB408						
表带和表扣	○	○	○	○	○	○
电子	X	○	○	○	○	○
电池	○	○	○	○	○	○

部件名称	有毒和危险品					
Alta HR Model FB408	铅 (Pb)	水银 (Hg)	镉 (Cd)	六价铬 (Cr(VI))	多溴化苯 (PBB)	多溴化二苯 醚 (PBDE)
充电线	X	○	○	○	○	○

本表格依据 SJ/T 11364 的规定编制

○ = 表示该有害物质在该部件所有均质材料中的含量均在 GB/T 26572规定的限量要求以下

X = 表示该有害物质至少在该部件的某一均质材料中的含量超出 GB/T 26572规定的限量要求

## Indonesia

51233/SDPPI/2017  
6953

## Israel

התאמה אישור 51-57868

המוצר של המודולארי בחלק טכני שינוי כל לבצע אי.

## Japan

Notice to the User: Regulatory content for this region can also be viewed on your device. To view content:

- While your tracker is charging, press the button on the charging cable six times to see the Regulatory screen.



201-163255



## Mexico



IFETEL: RCPFIFB16-2045

La operación de este equipo está sujeta a las siguientes dos condiciones:

1. Es posible que este equipo o dispositivo no cause interferencia perjudicial y
2. Este equipo o dispositivo debe aceptar cualquier interferencia, incluyendo la que pueda causar su operación no deseada

## Morocco

<p>AGREE PAR L'ANRT MAROC</p> <p>Numéro d'agrément: MR 16116 ANRT 2018</p> <p>Date d'agrément: 26/3/2018</p>
--

## Nigeria

Connection and use of this communications equipment is permitted by the Nigerian Communications Commission.

## Oman

OMAN-TRA/TA-R/3338/16  
D090258

## Philippines



## Serbia



И 005 016

## Singapore

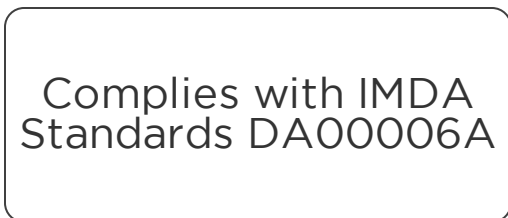

## South Africa



TA-2016/2940

## South Korea

Notice to the User: Regulatory content for this region can also be viewed on your device. To view content:

- While your tracker is charging, press the button on the charging cable six times to see the Regulatory screen.

클래스 B 장치 (가정 사용을 위한 방송 통신 기기): EMC 등록 주로 가정용 (B 급)으로 하고, 모든 지역에서 사용할 수 있습니다. 연결이 장치.

**\* 해당 무선설비는 전파혼신 가능성이 있으므로 인명안전과 관련된 서비스는 할 수 없습니다. \***



- |                                  |                   |
|----------------------------------|-------------------|
| - 사용 주파수 (Used frequency):       | 2402 MHz-2480 MHz |
| - 채널 수 (The number of channels): | 40                |
| - 변조방식 (Type of the modulation): | Digital           |
| - 안테나 유형 (Antenna Type):         | Vertical          |
| - 출력 (Output power):             | -2.22dBm          |
| - 안테나 종류 (Type of Antenna):      | Stamped Metal     |

### KC 인증서 정보 KC Certificate Information

- 1) 기기명 Equipment name (model name) 무선데이터통신시스템용 특정소출력무선 기기 FB408  
:

2) 인증번호 Certificate number :	MSIP-CMM-XRA-FB408
3) 상호 또는 성명 Applicant :	Fitbit, Inc.
4) 제조자 Manufacture:	Fitbit, Inc.
5) 제조 년월 Manufacture / Country of origin:	P.R.C.

## Taiwan

Fitbit Model FB408



CCA J16LP8650T2

注意！

依據 低功率電波輻射性電機管理辦法

第十二條 經型式認證合格之低功率射頻電機，非經許可，公司、商號或使用者均不得擅自變更頻率、加大功率或變更原設計之特性及功能

第十四條

低功率射頻電機之使用不得影響飛航安全及干擾合法通信；經發現有干擾現象時，應立即停用，並改善至無干擾時方得繼續使用。

前項合法通信，指依電信法規定作業之無線電通信。

低功率射頻電機須忍受合法通信或工業、科學及醫療用電波輻射性電機設備之干擾。

Article 12

Without permission, any company, firm or user shall not alter the frequency, increase the power, or change the characteristics and functions of the original design of the certified lower power frequency electric machinery.

Article 14

The application of low power frequency electric machineries shall not affect the navigation safety nor interfere a legal communication, if an interference is found, the service will be suspended until improvement is made and the interference no longer exists. The foregoing legal communication refers to the wireless telecommunication operated according to the telecommunications laws and regulations. The low power frequency electric machinery should be able to tolerate the interference of the electric wave radiation electric machineries and equipment for legal communications or industrial and scientific applications.

## United Arab Emirates

TRA Registered No.: ER51305/17

Dealer No.: DA35294/14

## Safety Statement

This equipment has been tested to comply with safety certification in accordance with the specifications of EN Standard: EN60950-1:2006 + A11:2009 + A1:2010 + A12:2011 + A2:2013.

©2018 Fitbit, Inc. All rights reserved. Fitbit and the Fitbit logo are trademarks or registered trademarks of Fitbit in the US and other countries. A more complete list of Fitbit trademarks can be found at <http://www.fitbit.com/legal/trademark-list>. Third-party trademarks mentioned are the property of their respective owners.