

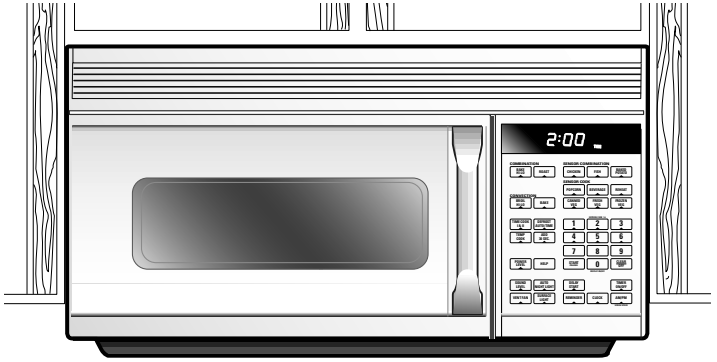

GEAppliances.com

Microwave Oven



Owner's Manual

JVM1190



IMPORTANT SAFETY INFORMATION. READ ALL INSTRUCTIONS BEFORE USING.

⚠ WARNING!

For your safety, the information in this manual must be followed to minimize the risk of fire or explosion, electric shock, or to prevent property damage, personal injury, or loss of life.

PRECAUTIONS TO AVOID POSSIBLE EXPOSURE TO EXCESSIVE MICROWAVE ENERGY



- **Do Not Attempt** to operate this oven with the door open since open-door operation can result in harmful exposure to microwave energy. It is important not to defeat or tamper with the safety interlocks.
- **Do Not Place** any object between the oven front face and the door or allow soil or cleaner residue to accumulate on sealing surfaces.
- **Do Not Operate** the oven if it is damaged. It is particularly important that the oven door close properly and that there is no damage to the:
 - 1 door (bent)
 - 2 hinges and latches (broken or loosened)
 - 3 door seals and sealing surfaces.
- **The Oven Should Not** be adjusted or repaired by anyone except properly qualified service personnel.



SAFETY PRECAUTIONS

This microwave oven is UL listed for installation over electric and gas ranges.

This microwave oven is not approved or tested for marine use.

- Read and follow the specific precautions in the *Precautions to Avoid Possible Exposure to Excessive Microwave Energy* section above.
- This appliance must be grounded. Connect only to a properly grounded outlet. See the *Grounding Instructions* section on page 9.
- Install or locate this appliance only in accordance with the provided Installation Instructions.
- Do not mount this appliance over a sink.

Use this appliance only for its intended purpose as described in this Owner's Manual.

- This over-the-range oven was designed for use over ranges no wider than 42 inches. It may be installed over both gas and electric cooking equipment.
- Do not operate this appliance if it has a damaged power cord or plug, if it is not working properly, or if it has been damaged or dropped.
- Do not cover or block any openings on the appliance.
- Use this appliance only for its intended use as described in this manual. Do not use corrosive chemicals or vapors in this appliance. This microwave oven is specifically designed to heat, dry or cook food, and is not intended for laboratory or industrial use.
- Do not store this appliance outdoors. Do not use this product near water—for example, in a wet basement, near a swimming pool or near a sink.
- Keep power cord away from heated surfaces.
- Do not immerse power cord or plug in water.
- See door surface cleaning instructions in the *Care and cleaning of the microwave oven* section of this manual.
- To reduce the risk of fire in the oven cavity:
 - Do not cover the shelf or any other part of the oven with metal foil. This will cause overheating of the microwave/convection oven.
 - Do not overcook food. Carefully attend appliance if paper, plastic or other combustible materials are placed inside the oven while cooking.
 - Remove wire twist-ties and metal handles from paper or plastic containers before placing them in the oven.
 - Do not use the oven for storage purposes. Do not leave paper products, cooking utensils or food in the oven when not in use.
 - If materials inside the oven should ignite, keep the oven door closed, turn the oven off and disconnect the power cord, or shut off power at the fuse or circuit breaker panel. If the door is opened, the fire may spread.
- This appliance should be serviced only by qualified service personnel. Contact nearest authorized service facility for examination, repair or adjustment.
- As with any appliance, close supervision is necessary when used by children.

IMPORTANT SAFETY INFORMATION. READ ALL INSTRUCTIONS BEFORE USING.

⚠ WARNING!



ARCING

If you see arcing, press the **CLEAR/OFF** pad and correct the problem.

Arcing is the microwave term for sparks in the oven. Arcing is caused by:

- The temperature probe in the microwave but not inserted in the food.
- The metal shelf not installed correctly so it touches the microwave wall.
- Metal or foil touching the side of the oven.
- Foil not molded to food (upturned edges act like antennas).
- Metal, such as twist-ties, poultry pins, or gold-rimmed dishes, in the microwave.
- Recycled paper towels containing small metal pieces being used in the microwave.



FOODS

- Do not pop popcorn in your microwave oven unless in a special microwave popcorn accessory or unless you use popcorn labeled for use in microwave ovens.
- Some products such as whole eggs and sealed containers—for example, closed jars—will explode and should not be heated in this microwave oven. Such use of the microwave oven could result in injury.
- Do not boil eggs in a microwave oven. Pressure will build up inside egg yolk and will cause it to burst, possibly resulting in injury.
- Operating the microwave with no food inside for more than a minute or two may cause damage to the oven and could start a fire. It increases the heat around the magnetron and can shorten the life of the oven.
- Foods with unbroken outer “skin” such as potatoes, hot dogs, sausages, tomatoes, apples, chicken livers and other giblets, and egg yolks should be pierced to allow steam to escape during cooking.

■ SUPERHEATED WATER

Microwaved water and other liquids do not always bubble when they reach the boiling point. They can actually get superheated and not bubble at all.

Superheated liquid will bubble up out of the cup when it is moved or when something like a spoon or tea bag is put into it.

To prevent this from happening and causing injury, do not heat any liquid for more than 2 minutes per cup. After heating, let the cup stand in the microwave for 30 seconds before moving it or putting anything into it.

- Avoid heating baby food in glass jars, even with the lid off. Make sure all infant food is thoroughly cooked. Stir food to distribute the heat evenly. Be careful to prevent scalding when warming formula. The container may feel cooler than the formula really is. Always test the formula before feeding the baby.
- Don't defrost frozen beverages in narrow-necked bottles (especially carbonated beverages). Even if the container is opened, pressure can build up. This can cause the container to burst, possibly resulting in injury.
- Spontaneous boiling—Under certain special circumstances, liquids may start to boil during or shortly after removal from the microwave oven. To prevent burns from splashing liquid, we recommend the following: before removing the container from the oven, allow the container to stand in the oven for 30 to 40 seconds after the oven has shut off. Do not boil liquids in narrow-necked containers such as soft drink bottles, wine flasks and especially narrow-necked coffee cups. Even if the container is opened, excessive steam can build up and cause it to burst or overflow.
- Hot foods and steam can cause burns. Be careful when opening any containers of hot food, including popcorn bags, cooking pouches and boxes. To prevent possible injury, direct steam away from hands and face.
- Do not overcook potatoes. They could dehydrate and catch fire, causing damage to your oven.
- When cooking pork, follow the directions exactly and always cook the meat to an internal temperature of at least 170°F. This assures that, in the remote possibility that trichina may be present in the meat, it will be killed and meat will be safe to eat.

IMPORTANT SAFETY INFORMATION. READ ALL INSTRUCTIONS BEFORE USING.

⚠ WARNING!



MICROWAVE-SAFE COOKWARE

Make sure all cookware used in your microwave oven is suitable for microwaving. Most glass casseroles, cooking dishes, measuring cups, custard cups, pottery or china dinnerware which does not have metallic trim or glaze with a metallic sheen can be used. Some cookware is labeled “suitable for microwaving.”

- If you are not sure if a dish is microwave-safe, use this test: Place in the oven both the dish you are testing and a glass measuring cup filled with 1 cup of water—set the measuring cup either in or next to the dish. Microwave 1 minute at high. If the dish heats, it should not be used for microwaving.

If the dish remains cool and only the water in the cup heats, then the dish is microwave-safe.

- If you use a meat thermometer while cooking, make sure it is safe for use in microwave ovens.
- Do not use paper products when the microwave/ convection oven is operated in the convection or combination mode.

- Do not use recycled paper products. Recycled paper towels, napkins and waxed paper can contain metal flecks which may cause arcing or ignite. Paper products containing nylon or nylon filaments should be avoided, as they may also ignite.
- Some styrofoam trays (like those that meat is packaged on) have a thin strip of metal embedded in the bottom. When microwaved, the metal can burn the floor of the oven or ignite a paper towel.
- Do not use the microwave to dry newspapers.
- Not all plastic wrap is suitable for use in microwave ovens. Check the package for proper use.
- Paper towels, waxed paper and plastic wrap can be used to cover dishes in order to retain moisture and prevent spattering. Be sure to vent plastic wrap so steam can escape.
- Cookware may become hot because of heat transferred from the heated food. Pot holders may be needed to handle the cookware.

- “Boilable” cooking pouches and tightly closed plastic bags should be slit, pierced or vented as directed by package. If they are not, plastic could burst during or immediately after cooking, possibly resulting in injury. Also, plastic storage containers should be at least partially uncovered because they form a tight seal. When cooking with containers tightly covered with plastic wrap, remove covering carefully and direct steam away from hands and face.
- Plastic cookware—Plastic cookware designed for microwave cooking is very useful, but should be used carefully. Even microwave-safe plastic may not be as tolerant of overcooking conditions as are glass or ceramic materials and may soften or char if subjected to short periods of overcooking. In longer exposures to overcooking, the food and cookware could ignite.

Follow these guidelines:

- 1 Use microwave-safe plastics only and use them in strict compliance with the cookware manufacturer’s recommendations.
 - 2 Do not microwave empty containers.
 - 3 Do not permit children to use plastic cookware without complete supervision.
- Use foil only as directed in this guide. TV dinners may be microwaved in foil trays less than 3/4” high; remove the top foil cover and return the tray to the box. When using foil in the microwave oven, keep the foil at least 1 inch away from the sides of the oven.

IMPORTANT SAFETY INFORMATION. READ ALL INSTRUCTIONS BEFORE USING.

⚠ WARNING!



THE VENT FAN

The fan will operate automatically under certain conditions (see the *Automatic Fan* section). Take care to prevent the starting and spreading of accidental cooking fires while the vent fan is in use.

- Clean the underside of the microwave often. Do not allow grease to build up on the microwave or the fan filters.
- In the event of a grease fire on the surface units below the microwave oven, smother a flaming pan on the surface unit by covering the pan completely with a lid, a cookie sheet or a flat tray.
- Use care when cleaning the vent fan filters. Corrosive cleaning agents, such as lye-based oven cleaners, may damage the filters.
- When flaming foods under the microwave, turn the vent fan off. The fan, if operating, may spread the flame.
- Never leave surface units beneath your microwave oven unattended at high heat settings. Boilovers cause smoking and greasy spillovers that may ignite and spread if the microwave vent fan is operating. To minimize automatic fan operation, use adequate sized cookware and use high heat on surface units only when necessary.

⚠ WARNING!

Improper use of the grounding plug can result in a risk of electric shock.



GROUNDING INSTRUCTIONS

This appliance must be grounded. In the event of an electrical short circuit, grounding reduces the risk of electric shock by providing an escape wire for the electric current.

This appliance is equipped with a power cord having a grounding wire with a grounding plug. The plug must be plugged into an outlet that is properly installed and grounded.

Consult a qualified electrician or service technician if the grounding instructions are not completely understood, or if doubt exists as to whether the appliance is properly grounded.

If the outlet is a standard 2-prong wall outlet, it is your personal responsibility and obligation to have it replaced with a properly grounded 3-prong wall outlet.

Do not under any circumstances cut or remove the third (ground) prong from the power cord.

Do not use an adapter plug with this appliance.

Do not use an extension cord with this appliance. If the power cord is too short, have a qualified electrician or service technician install an outlet near the appliance.

For best operation, plug this appliance into its own electrical outlet to prevent flickering of lights, blowing of fuse or tripping of circuit breaker.

Read and follow this Safety Information carefully.

SAVE THESE INSTRUCTIONS



Congratulations! You Are Now Part of the GE Family.

Welcome to the GE family. We're proud of our quality products and we are committed to providing dependable service. You'll see it in this easy-to-use Owner's Manual and you'll hear it in the friendly voices of our customer service department.

Best of all, you'll experience these values each time you use your microwave oven. That's important, because your new microwave oven will be part of your family for many years. And we hope you will be part of ours for a long time to come.

We thank you for buying GE. We appreciate your purchase, and hope you will continue to rely on us whenever you need quality appliances for your home.



Important!

Staple sales slip or cancelled check here.

Proof of the original purchase date is needed to obtain service under the warranty.



Write the model and serial numbers here.

#

#

You can find them on a label inside the oven.

GE & You, A Service Partnership.

Ask any GE appliance owner and they will tell you we stand behind our products with unmatched quality service. However, did you know that most questions result from simple problems that you can easily fix yourself in just a few minutes? This Owner's Manual can tell you how.



Read this Manual

Inside you will find many helpful hints on how to use and maintain your microwave oven properly. Just a little preventive care on your part can save you a great deal of time and money over the life of your microwave oven.



Review the Section on Troubleshooting Tips

You'll find many answers to common problems here. If you review our chart of Troubleshooting Tips first, you may not need to call for service at all.



If You Need Service

If you do need service, you can relax knowing help is only a phone call away. A list of toll-free customer service numbers is included in the back section. Or you can always call the GE Answer Center® at 800.626.2000, 24 hours a day, 7 days a week.

Safety Information

Precautions to Avoid Possible Exposure to Excessive Microwave Energy	2
Safety Precautions	2, 3
Arcing	4
Foods	4, 5
Microwave-Safe Cookware	6, 7
The Vent Fan	8
Grounding Instructions	9

Safety Information

Operating Instructions

Microwave Oven Features	12–15
Microwave/Convection Cooking	16, 17
Changing Power Level	18
Time Features	19–27
Auto Feature	28
Temperature Features	29–33
Sensor Features	34–38
Other Features	38–42
Microwave Terms	43
Care and Cleaning	44–48

Operating Instructions

Troubleshooting Tips

Before You Call For Service	49, 50
Things That Are Normal With Your Microwave Oven	50

Troubleshooting Tips

Customer Service

Warranty	51
Service Telephone Numbers	Back Cover





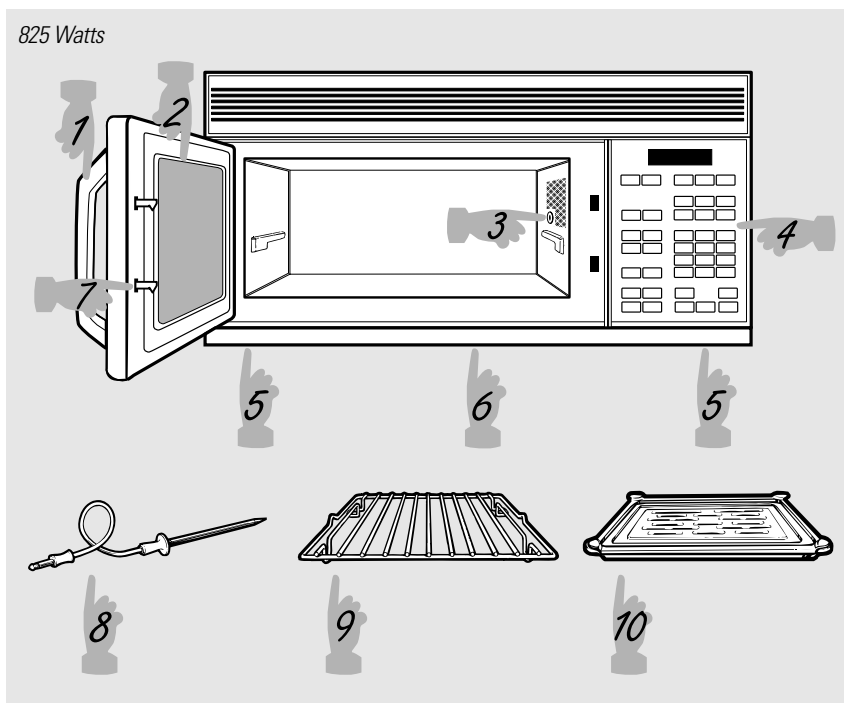

Customer Service

About the features of your microwave oven.

Throughout this manual, features and appearance may vary from your model.





Features of the Oven

-  **1 Door Handle.** Pull to open the door. The door must be securely latched for the microwave to operate.
-  **2 Window with Metal Shield.** Screen allows cooking to be viewed while keeping microwaves confined in the oven.
-  **3 Receptacle for Temperature Probe.** Probe must be securely inserted into the receptacle before the oven will **Temp Cook, Convection Temperature Bake, Combination Temperature Bake, or Combination Roast.**
-  **4 Touch Control Panel Display.**
-  **5 Grease Filters.**
-  **6 Cooktop Light.**

 **7 Door Latches.**

 **8 Temperature Probe.** Use with **Temp Cook, Convection Temperature Bake, Combination Temperature Bake,** or **Combination Roast** only.

 **9 Shelf.** The metal shelf must be in place on the oven floor when convection or combination cooking. For sensor combination cooking or convection broiling, the shelf must be on the upper supports. Remove the shelf for microwave-only cooking.

 **10 Broiler Pan.** Consists of a drip pan and a spatter shield. See the *Convection Broiling* section for instructions.

NOTE: Rating plate, oven vent(s) and oven light are located on the inside walls of the microwave oven.

Optional Kits

Filler Panel Kits

- JX40WH—White
- JX41—Black
- JX40AL—Almond

When replacing a 36" range hood, filler panel kits fill in the additional width to provide a custom built-in appearance.

For installation between cabinets only; not for end-of-cabinet installation. Each kit contains two 3"-wide filler panels.

Filter Kit

- JX81—Recirculating Charcoal Filter Kit

Filter kits are used when the microwave oven cannot be vented to the outside.

Decorative Panel Kit

- JX22SS—Stainless Steel

When replacing a Hi/Low range, the decorative panel kit fills in the area between the microwave and the range left by the Hi/Low model.

Available at extra cost from your GE supplier.

About the features of your microwave oven.

You can cook with convection heat, microwaves, or a combination of both. You can cook by time or temperature.

You can also let the microwave choose the settings automatically by using the sensor features.

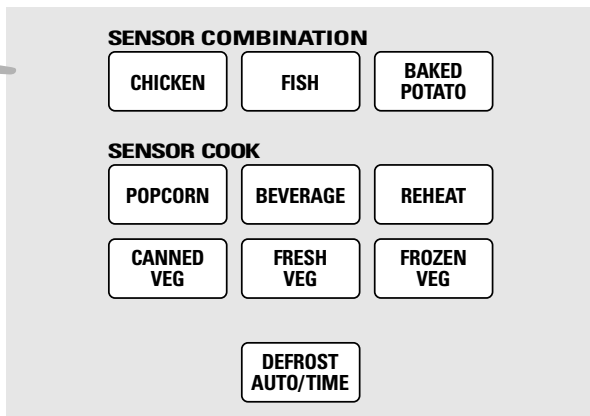
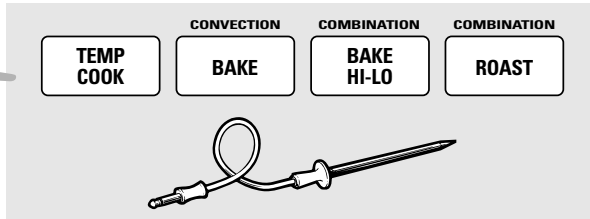
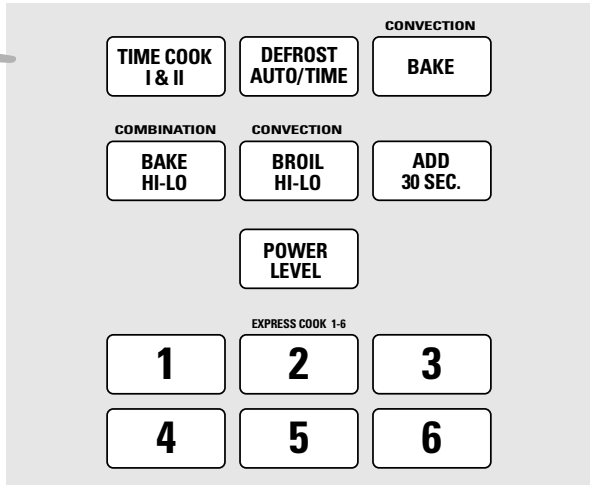



Cooking Controls



Time Features

<i>Press</i>	<i>Enter</i>
TIME COOK I & II Press once or twice	Amount of cooking time.
DEFROST AUTO/TIME Press twice	Amount of defrosting time.
Convection BAKE	Oven temperature and amount of cooking time.
Combination BAKE HI-LO Press once or twice	Oven temperature and amount of cooking time.
Convection BROIL HI-LO Press once or twice	High or Low temperature automatically selected. Enter amount of broiling time.
EXPRESS COOK	Starts immediately!
ADD 30 SEC	Starts immediately!
POWER LEVEL	Power level 1–10.



Temperature Features—Probe Cooking

<i>Press</i>	<i>Enter</i>
TEMP COOK	Food temperature.
Convection BAKE	Oven temperature and food temperature.
Combination BAKE HI-LO Press once or twice	Oven temperature and food temperature.
Combination ROAST Press once	MEDIUM automatically selected.
Combination ROAST Press twice	WELL automatically selected.



Sensor Features and Auto Feature

<i>Press</i>	<i>Enter</i>	<i>Option</i>
Sensor Combination CHICKEN	Press START .	
Sensor Combination FISH	Press START .	
Sensor Combination BAKED POTATO	Press START .	
Sensor Cook POPCORN	Starts immediately!	more/less time
Sensor Cook BEVERAGE	Starts immediately!	
Sensor Cook REHEAT	Starts immediately!	more/less time
Sensor Cook CANNED VEG	Starts immediately!	
Sensor Cook FRESH VEG	Starts immediately!	more/less time
Sensor Cook FROZEN VEG	Starts immediately!	

<i>Press</i>	<i>Enter</i>
DEFROST AUTO/TIME Press once	Food weight.

About microwave/convection cooking.

How It Works

Microwave cooking uses very short, high frequency radio waves. The movement of the microwaves through the food creates heat and cooks most foods faster than regular methods. Microwave cooking heats the food, not the cookware or the interior of the oven.

Convection cooking constantly circulates heated air around the food. It creates even browning and sealed-in flavor by the motion of hot air over the food surfaces.

Using a combination of microwave and convection cooking is also an option.

You can cook by time or by temperature. When cooking by temperature, the temperature probe monitors the internal temperature of the food to let you know when it is ready.

Comparison Guide

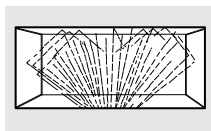

Microwave

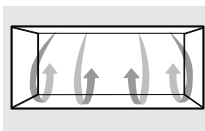

Convection

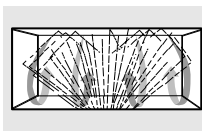

Combination

	Microwave	Convection	Combination
Cooking Method	Microwave energy is distributed evenly for fast, thorough cooking.	Hot air circulates around food to produce browned exteriors and seal in juices.	Microwave energy and convection heat combine to cook foods.
Heat Source	Microwave energy.	Circulating heated air.	Microwave energy and circulating heated air.
Heat Conduction	Heat produced within food by instant energy penetration.	Heat conducted from outside of food to inside.	Food heats from instant energy penetration and heat conducted from outside of food.
Benefits	Fast, high-efficiency cooking. Oven and surroundings do not get hot. Easy clean-up.	Aids in browning and seals in flavor. Cooks some foods faster than regular ovens.	Shortened cooking time from microwave energy, plus browning and crisping from convection heat.

Cookware Guide

Cookware	Microwave	Convection	Combination
Heat-Resistant Glass, Glass-Ceramic (Pyrex®, Fire King®, Corning Ware®, etc.)	YES	YES	YES
Ceramic (cookware with no metal trim)	YES	YES	YES
Metal	NO	YES	NO
Non Heat-Resistant Glass	NO	NO	NO
Microwave-Safe Plastics	YES	NO	SOMETIMES*
Plastic Films and Wraps	YES	NO	NO
Paper Products	YES	NO	NO
Straw, Wicker and Wood	YES	NO	NO

*Use only microwave cookware that is safe to 400°F.

Cookware Tips

Convection Cooking

Metal pans are recommended for all types of baked products.

Dark or dull finish metal pans are best for breads and pies because they absorb heat and produce crisper crust.

Shiny aluminum pans are better for cakes, cookies or muffins because these pans reflect heat and help produce a light, tender crust.

Use **glass or glass-ceramic** casserole or baking dishes for egg and cheese recipes because they are easier to clean.

Combination Cooking

Use **glass or glass-ceramic** baking containers. Do not use cookware with metal trim. It may cause arcing which can damage the cookware, the shelf or the oven.

Heat-resistant plastic microwave cookware (safe to 400°F.) may be used.

About changing the power level.

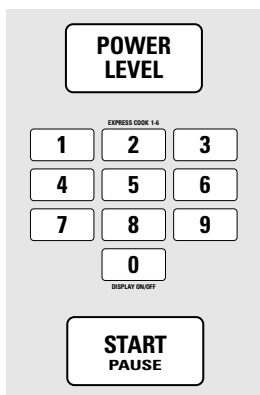

The power level may be entered or changed immediately after entering the feature time for **Time Cook**, **Time Defrost** or **Express Cook**. The power level may also be changed during time countdown.

- 1 Press **TIME COOK I & II** or select **Time Defrost**.
- 2 Enter cooking or defrosting time.
- 3 Press **POWER LEVEL**.
- 4 Select desired power level 1–10.
- 5 Press **START**.

Variable power levels add flexibility to microwave cooking. The power levels on the microwave oven can be compared to the surface units on a range. Each power level gives you microwave energy a certain percent of the time. **Power level 7** is microwave energy 70% of the time. **Power level 3** is energy 30% of the time. Most cooking will be done on **High (power level 10)** which gives you 100% power. **Power level 10** will cook faster but food may need more frequent stirring, rotating or turning over. A lower setting will cook more evenly and need less stirring or rotating of the food. Some foods may have better flavor, texture or appearance if one of the lower settings is used. Use a lower power level when cooking foods that have a tendency to boil over, such as scalloped potatoes.

Rest periods (when the microwave energy cycles off) give time for the food to “equalize” or transfer heat to the inside of the food. An example of this is shown with **power level 3**—the defrost cycle. If microwave energy did not cycle off, the outside of the food would cook before the inside was defrosted.

Here are some examples of uses for various power levels:

High 10: Fish, bacon, vegetables, boiling liquids.

Med-High 7: Gentle cooking of meat and poultry; baking casseroles and reheating.

Medium 5: Slow cooking and tenderizing for stews and less tender cuts of meat.

Low 3: Defrosting; simmering; delicate sauces.

Warm 1: Keeping food warm; softening butter.

About the time features.

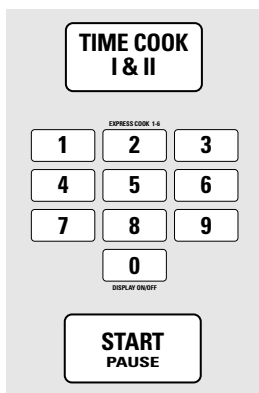

Time Cook I & II

Time Cook I

Allows you to microwave for any time up to 99 minutes and 99 seconds.

Power level 10 (High) is automatically set, but you may change it for more flexibility.

- 1 Press **TIME COOK I & II**.
- 2 Enter cooking time.
- 3 Change power level if you don't want full power. (Press **POWER LEVEL**. Select a desired power level 1–10.)
- 4 Press **START**.

You may open the door during **Time Cook** to check the food. Close the door and press **START** to resume cooking.

Time Cook II

Lets you change power levels automatically during cooking. Here's how to do it:

- 1 Press **TIME COOK I & II**.
- 2 Enter the first cook time.
- 3 Change the power level if you don't want full power. (Press **POWER LEVEL**. Select a desired power level 1–10.)
- 4 Press **TIME COOK I & II** again.
- 5 Enter the second cook time.
- 6 Change the power level if you don't want full power. (Press **POWER LEVEL**. Select a desired power level 1–10.)
- 7 Press **START**.

At the end of **Time Cook I**, **Time Cook II** counts down.

About the time features.

Cooking Guide for Time Cook I & II

NOTE: Use power level **High (10)** unless otherwise noted.

Vegetable	Amount	Time	Comments
Asparagus (fresh spears)	1 lb.	7 to 9 min., Med-High (7)	In 1½-qt. oblong glass baking dish, place 1/4 cup water. Rotate dish after half of time.
(frozen spears)	10-oz. package	5 to 7 min.	In 1-qt. casserole.
Beans (fresh green)	1 lb. cut in half	10 to 12 min.	In 1½-qt. casserole, place 1/2 cup water.
(frozen green)	10-oz. package	6 to 8 min.	In 1-qt. casserole, place 2 tablespoons water.
(frozen lima)	10-oz. package	6 to 8 min.	In 1-qt. casserole, place 1/4 cup water.
Beets (fresh, whole)	1 bunch	18 to 22 min.	In 2-qt. casserole, place 1/2 cup water.
Broccoli (fresh cut)	1 bunch (1¼ to 1½ lbs.)	8 to 10 min.	In 2-qt. casserole, place 1/2 cup water.
(fresh spears)	1 bunch (1¼ to 1½ lbs.)	10 to 13 min.	In 2-qt. oblong glass baking dish, place 1/4 cup water. Rotate dish after half of time.
(frozen, chopped)	10-oz. package	5 to 7 min.	In 1-qt. casserole.
(frozen spears)	10-oz. package	5 to 7 min.	In 1-qt. casserole, place 3 tablespoons water.
Cabbage (fresh)	1 medium head (about 2 lbs.)	9 to 11 min.	In 1½- or 2-qt. casserole, place 1/4 cup water.
(wedges)		8 to 10 min.	In 2- or 3-qt. casserole, place 1/4 cup water.
Carrots (fresh, sliced)	1 lb.	7 to 9 min.	In 1½-qt. casserole, place 1/4 cup water.
(frozen)	10-oz. package	5 to 7 min.	In 1-qt. casserole, place 2 tablespoons water.
Cauliflower (flowerets)	1 medium head	10 to 14 min.	In 2-qt. casserole, place 1/2 cup water.
(fresh, whole)	1 medium head	10 to 17 min.	In 2-qt. casserole, place 1/2 cup water.
(frozen)	10-oz. package	5 to 7 min.	In 1-qt. casserole, place 2 tablespoons water.

Vegetable	Amount	Time	Comments
Corn (frozen kernel)	10-oz. package	5 to 7 min.	In 1-qt. casserole, place 2 tablespoons water.
Corn on the cob (fresh)	1 to 5 ears	3 to 4 min. per ear	In 2-qt. oblong glass baking dish, place corn. If corn is in husk, use no water; if corn has been husked, add 1/4 cup water. Rearrange after half of time.
(frozen)	1 ear 2 to 6 ears	5 to 6 min. 3 to 4 min. per ear	Place in 2-qt. oblong glass baking dish. Cover with vented plastic wrap. Rearrange after half of time.
Mixed vegetables (frozen)	10-oz. package	5 to 7 min.	In 1-qt. casserole, place 3 tablespoons water.
Peas (fresh, shelled)	2 lbs. unshelled	10 to 12 min.	In 1-qt. casserole, place 1/4 cup water.
(frozen)	10-oz. package	5 to 7 min.	In 1-qt. casserole, place 2 tablespoons water.
Potatoes (fresh, cubed, white)	4 potatoes (6 to 8 oz. each)	10 to 12 min.	Peel and cut into 1-inch cubes. Place in 2-qt. casserole with 1/2 cup water. Stir after half of time.
(fresh, whole, sweet or white)	1 (6 to 8 oz.)	3 to 4 min.	Pierce with cooking fork. Place in center of the oven. Let stand 5 minutes.
Spinach (fresh)	10 to 16 oz.	5 to 7 min.	In 2-qt. casserole, place washed spinach.
(frozen, chopped, and leaf)	10-oz. package	5 to 7 min.	In 1-qt. casserole, place 3 tablespoons water.
Squash (fresh, summer and yellow)	1 lb. sliced	5 to 7 min.	In 1½-qt. casserole, place 1/4 cup water.
(winter, acorn, or butternut)	1 to 2 squash (about 1 lb. each)	8 to 11 min.	Cut in half and remove fibrous membranes. In 2-qt. oblong glass baking dish, place squash cut-side-down. Turn cut-side-up after 4 minutes.

About the time features.

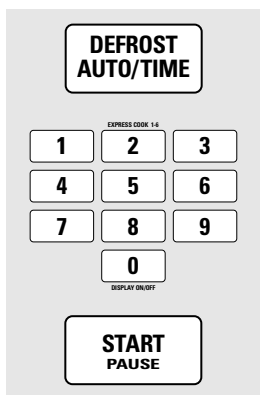

Time Defrost

Allows you to defrost for a selected length of time. See the *Defrosting Guide* for suggested times. (**Auto Defrost** explained in the *About the auto feature* section.)

- 1 Press **DEFROST AUTO/TIME** twice.
- 2 Enter defrosting time.
- 3 Press **START**.
- 4 Turn food over when the oven signals.
- 5 Press **START**.

Power level is automatically set at 3, but can be changed. You can defrost small items quickly by raising the power level after entering the time. **Power level 7** cuts the total defrosting time in about half; **power level 10** cuts the total time to approximately 1/3. However, food will need more frequent attention than usual.

At one half of selected defrosting time, the oven signals **TURN**. At this time, turn food over and break apart or rearrange pieces for more even defrosting. Shield any warm areas with small pieces of foil. The oven will continue to defrost if you don't open the door and turn the food.

A dull thumping noise may be heard during defrosting. This is normal when oven is not operating at **High** power.

Defrosting Tips

- Foods frozen in paper or plastic can be defrosted in the package. Closed packages should be slit, pierced or vented **AFTER** food has partially defrosted. Plastic storage containers should be partially uncovered.
- Family-size, prepackaged frozen dinners can be defrosted and microwaved. If the food is in a foil container, transfer it to a microwave-safe dish.
- Foods that spoil easily should not be allowed to sit out for more than one hour after defrosting. Room temperature promotes the growth of harmful bacteria.
- For more even defrosting of larger foods, such as roasts, use **Auto Defrost**. Be sure large meats are completely defrosted before cooking.
- When defrosted, food should be cool but softened in all areas. If still slightly icy, return to the microwave very briefly, or let it stand a few minutes.

Defrosting Guide

Food	Time	Comments
Breads, Cakes <i>Bread, buns or rolls (1 piece)</i> <i>Sweet rolls (approx. 12 oz.)</i>	1 min. 3 to 5 min.	
Fish and Seafood <i>Fillets, frozen (1 lb.)</i> <i>Shellfish, small pieces (1 lb.)</i>	7 to 9 min. 5 to 7 min.	Place block in casserole. Turn over and break up after half the time.
Fruit <i>Plastic pouch—1 or 2 (10-oz. package)</i>	3 to 6 min.	
Meat <i>Bacon (1 lb.)</i> <i>Franks (1 lb.)</i> <i>Ground meat (1 lb.)</i> <i>Roast: beef, lamb, veal, pork</i> <i>Steaks, chops and cutlets</i>	3 to 5 min. 3 to 5 min. 5 to 7 min. 12 to 16 min. per lb. 6 to 8 min. per lb.	Place unopened package in oven. Let stand 5 minutes after defrosting. Place unopened package in oven. Microwave just until franks can be separated. Let stand 5 minutes, if necessary, to complete defrosting. Turn meat over after half the time. Use power level 1 . Place unwrapped meat in cooking dish. Turn over after half the time and shield warm areas with foil. When finished, separate pieces and let stand to complete defrosting.
Poultry <i>Chicken, broiler-fryer cut up (2½ to 3 lbs.)</i> <i>Chicken, whole (2½ to 3 lbs.)</i> <i>Cornish hen</i> <i>Turkey breast (4 to 6 lbs.)</i>	16 to 20 min. 18 to 22 min. 8 to 14 min. per lb. 6 to 10 min. per lb.	Place wrapped chicken in dish. Unwrap and turn over after half the time. When finished, separate pieces and microwave 2 to 4 minutes more, if necessary. Let stand to finish defrosting. Place wrapped chicken in dish. After half the time, unwrap and turn chicken over. Shield warm areas with foil. Finish defrosting. If necessary, run cold water in the cavity until giblets can be removed. Place unwrapped hen in the oven breast-side-up. Turn over after half the time. Run cool water in the cavity until giblets can be removed. Place unwrapped breast in dish breast-side-down. After half the time, turn over and shield warm areas with foil. Finish defrosting. Let stand 1 to 2 hours in refrigerator to complete defrosting.

About the time features.

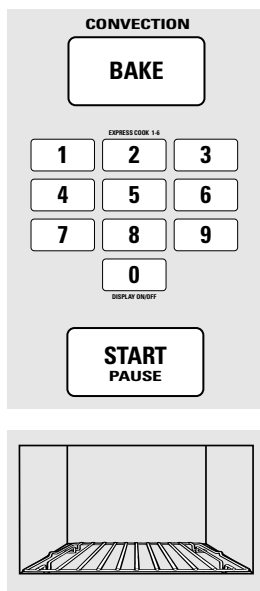

Use the shelf on the oven floor when convection baking.

Convection Bake

During convection baking a heating element is used to raise the temperature of the air inside the oven. Any oven temperature from 225°F. to 450°F. may be programmed. A fan circulates the heated air throughout the oven, over and around the food, producing golden brown exteriors and rich, moist interiors.

- 1 Press **Convection BAKE**.
- 2 Enter the desired oven temperature.
- 3 To preheat, press **START**.
- 4 When the temperature is reached, the oven signals. If you do not open the door within 30 minutes the oven will turn off automatically. Place the food in the oven.
- 5 Enter the desired baking time.
- 6 Press **START**.

If you do not want to preheat, skip steps 3 and 4.

For Best Results

- Allow at least one inch between the pan and the walls of the oven.
- When converting your favorite recipe from regular oven baking to convection baking, lower the oven temperature 25–50°F. and check food at the minimum time.

Cooking Tip

Some foods cook faster using convection baking than in regular oven cooking.

Resume Feature

If your foods are not quite done you can bake them for two more minutes at your previous settings using the **Resume** feature. You need to start the steps below within one minute of oven shutoff.

- 1 Press **Convection BAKE**.
- 2 Press **START**.

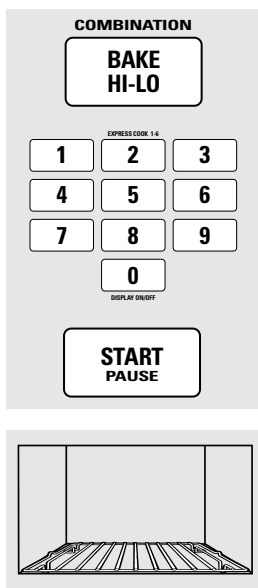

Use the shelf on the oven floor when combination baking.

Combination Bake

Combination baking combines microwave cooking and convection cooking. The microwave energy cooks food quickly and convection circulation of heated air browns foods beautifully.

- 1** Press **Combination BAKE HI-LO** once for High (30% microwave power) or twice for Low (10% microwave power).
- 2** Enter the desired oven temperature.
- 3** To preheat, press **START**.
- 4** When the temperature is reached, the oven signals. If you do not open the door within 30 minutes the oven will turn off automatically. Place the food in the oven.
- 5** Enter the desired baking time.
- 6** Press **START**.

If you do not want to preheat, skip steps 3 and 4.

For Best Results

- Allow at least one inch between the pan and the walls of the oven.
- When converting your favorite recipe from regular oven baking to convection baking, lower the oven temperature 25–50°F, and check food at the minimum time.

Cooking Tips

- Do not use metal cookware with **Combination Bake**.
- Check the *Cookware Guide* in the *About microwave/convection cooking* section for correct cookware when combination baking.
- Place meat in a glass dish on a trivet to collect juices and prevent spattering.

About the time features.

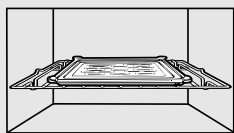
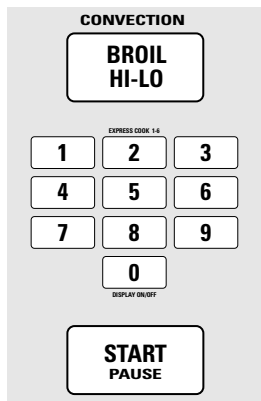

Convection Broil—Place the broiler pan (spatter shield and drip pan) on top of the shelf.

Convection Broil

Broiling is cooking by intense top heat. The metal shelf must be in place on the shelf supports when convection broiling. Most fish and tender cuts of meat can be broiled.

- 1** Press **Convection BROIL HI-LO** once for High (450°F.) or twice for Low (425°F.).
- 2** To preheat, press **START**.
- 3** When the temperature is reached, the oven signals. Place the food on the broiler pan and place it on the oven shelf. If the oven door remains closed, the oven will hold the temperature for 30 minutes and then shut off.
- 4** Enter the desired broiling time.
- 5** Press **START**.

If you do not want to preheat, skip steps 2 and 3.

Cooking Tips

- If meat has fat or gristle around the edge, cut vertical slashes through both about 2 inches apart. If desired, fat may be trimmed, leaving a layer about 1/8 inch thick. This will help keep spattering and smoking to a minimum.
- When using the broiler pan, be sure to use the spatter shield; otherwise, meat juices may become hot enough to catch fire.
- If you use aluminum foil to line the drip pan or spatter shield, you must mold the foil tightly to it. Cut slits in the spatter shield so fat and meat juices drain into the drip pan.



Express Cook

This is a quick way to set cooking time for 1–6 minutes.

Press one of the **Express Cook** pads (from 1 to 6) for 1 to 6 minutes of cooking at **power level 10**. For example, press the **2** pad for 2 minutes of cooking time.

The power level can be changed as time is counting down. Press **POWER LEVEL** and enter 1–10.



Add 30 Seconds

You can use this feature two ways:

- It will add 30 seconds to the time counting down each time the pad is pressed.
- It can be used as a quick way to set 30 seconds of cooking time.

About the auto feature.

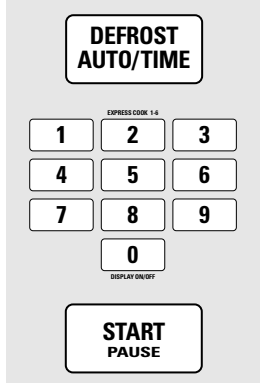

Auto Defrost

The **Defrost Auto/Time** feature gives you two ways to defrost frozen foods. Press **DEFROST AUTO/TIME** once for **Auto Defrost** or twice for **Time Defrost**.

Use **Auto Defrost** for meat, poultry and fish up to 6 pounds. Use **Time Defrost** for most other frozen foods.

- 1 Press **DEFROST AUTO/TIME** once.
- 2 Using the *Conversion Guide* below, enter food weight. For example, press pads **1** and **2** for 1.2 pounds (1 pound, 3 ounces).
- 3 Press **START**.

(**Time Defrost** is explained in the *About the time features* section.)

Auto Defrost automatically sets the defrosting times and power levels to give even defrosting results for meats, poultry and fish.

- Remove meat from package and place on microwave-safe dish.
- Twice during defrost, the oven signals **TURN**. At each **TURN** signal, turn the food over. Remove defrosted meat or shield warm areas with small pieces of foil.
- After defrosting, most meats need to stand 5 minutes to complete defrosting. Large roasts should stand for about 30 minutes.

Conversion Guide

If the weight of food is stated in pounds and ounces, the ounces must be converted to tenths (.1) of a pound.

Weight of Food in Ounces	Enter Food Weight (tenths of a pound)
1-2	.1
3	.2
4-5	.3
6-7	.4
8	.5
9-10	.6
11	.7
12-13	.8
14-15	.9

About the temperature features.

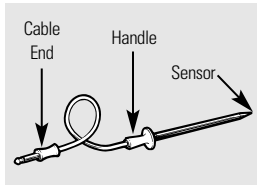

Appearance may vary.

The Temperature Probe

The temperature probe is a food thermometer that monitors the temperature of the food. The probe must be used when using **Temp Cook**, **Convection Temperature Bake**, **Combination Temperature Bake**, or **Combination Roast**.

Cooking with the probe allows you to heat food to a certain temperature. This is the best way to cook many foods.

The probe is not recommended for batters, doughs, frozen foods and foods which are difficult to cook precisely by temperature. Use the **Time Cook** setting for these foods.

- Make sure the cable end is inserted all the way into the oven wall receptacle.
- Insert the probe into the center of the food. Make sure the handle does not touch the food or the top or sides of the oven.
- Do not leave the probe in the oven if it's not inserted in food. If it touches the oven wall, it may damage the oven.

Cooking Tips

- Do not twist, drop or bend the probe.
- Be sure frozen food has been completely defrosted before inserting the probe. The probe may break off if used in frozen foods.
- Cover foods loosely for moisture control and quick, even heating.
- Use a lower power level with the probe; foods will take longer to cook but they will heat more evenly.

About the temperature features.

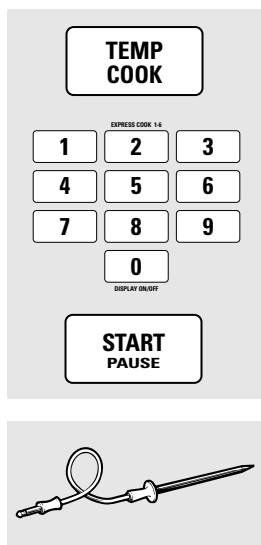

Temp Cook

- 1 Insert the temperature probe in the center of the food and attach it securely in the oven wall.
- 2 Press **TEMP COOK**.
- 3 Enter the desired food temperature.
- 4 Change power level if you don't want full power. (Press **POWER LEVEL**. Select a power level 1–10.)
- 5 Press **START**.
- 6 When the temperature is reached, the microwave will signal. Food will be held at this temperature for 60 minutes. The oven beeps when the hold time is complete.

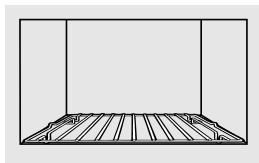
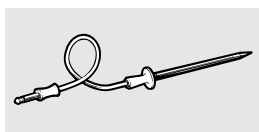
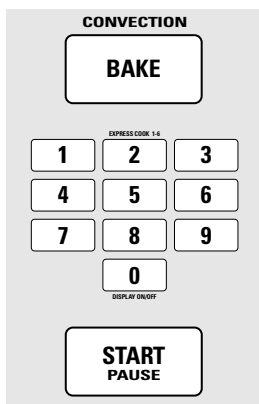

Use the shelf on the oven floor when convection baking.

Convection Temperature Bake

Convection baking with the temperature probe allows you to cook foods precisely to the degree of doneness desired, while the constantly circulating hot air assures even cooking and browning.

- 1 Insert the probe in the food and attach it securely to the oven wall.
- 2 Press **Convection BAKE**.
- 3 Enter the desired oven temperature.
- 4 Enter the desired food temperature. Any food temperature from 90°F. to 199°F. may be programmed.
- 5 Press **START**.

The temperature probe monitors the temperature of the food and turns the oven off automatically when the desired temperature is reached.

For Best Results

- Allow at least one inch between the pan and the walls of the oven.
- When converting your favorite recipe from regular oven baking to convection baking, lower the oven temperature 25–50°F. and check food at minimum time.

About the temperature features.

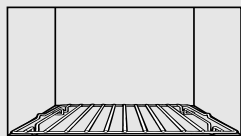
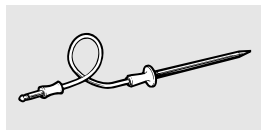
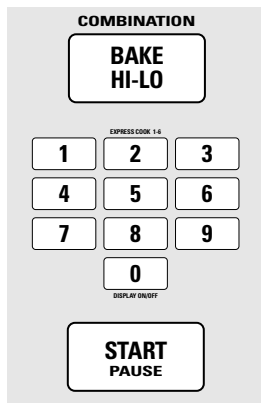

Use the shelf on the oven floor when combination baking.

Combination Temperature Bake

Combination baking with the temperature probe allows you to enjoy the benefits of combination baking with the precision of the temperature probe.

- 1 Insert the probe in the food and attach it securely to the oven wall.
- 2 Press **Combination BAKE HI-LO** once for High (30% microwave power) or twice for Low (10% microwave power).
- 3 Enter the desired oven temperature.
- 4 Enter the desired food temperature. Any food temperature from 90°F. to 199°F. may be programmed.
- 5 Press **START**.

The temperature probe monitors the temperature of the food and turns the oven off automatically when the desired temperature is reached.

For Best Results

- Allow at least one inch between the pan and the walls of the oven.
- When converting your favorite recipe from regular oven baking to convection baking, lower the oven temperature 25–50°F. and check food at minimum time.

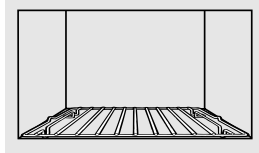
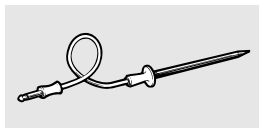
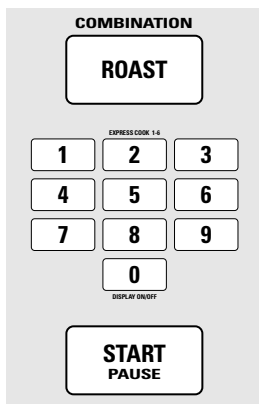

Use the shelf on the oven floor when combination roasting.

Combination Roast

Combination Roast is similar to **Combination Temperature Bake**. It uses both microwave and convection cooking as well as the temperature probe.

- 1 Insert the probe in the food and attach it securely to the oven wall.
- 2 Press **Combination ROAST** once for medium or twice for well done.
- 3 Press **START**.

When the programmed temperature is reached, the oven holds the food at that temperature for up to 1 hour.

Cooking Tips

- The metal shelf must be on the oven floor during **Combination Roast**.
- Place food in a glass dish on a trivet.
- Just as in regular roasting, only tender roasts should be roasted by using the probe. Less tender roasts should be microwaved by time.
- Insert the probe horizontally into the center meaty area not touching bone or fat. Make sure the handle does not touch the food or the top or sides of the oven.

About the sensor features.

Humidity Sensor

The **Sensor Features** detect the increasing humidity released during cooking. The oven automatically adjusts the cooking time to various types and amounts of food.

Sensor Cook Features

The **Sensor Cook** features use microwave energy to cook food.

NOTE: Do not use the shelf with the Sensor Cook features.

- The proper containers and covers are essential for best sensor cooking.

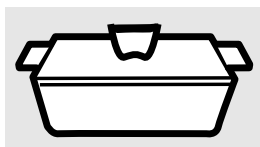

Covered

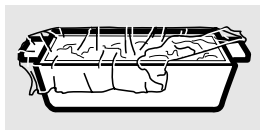

Vented



Dry off dishes so they don't mislead the sensor.

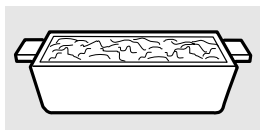

Uncovered

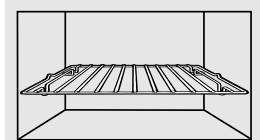

Place shelf on upper supports.

- Always use microwave-safe containers and cover them with lids or vented plastic wrap. Never use tight sealing plastic containers—they can prevent steam from escaping and cause food to overcook.
- Be sure the outside of the cooking containers and the inside of the microwave oven are dry before placing food in the oven. Beads of moisture turning into steam can mislead the sensor.

Sensor Combination Features

The **Sensor Combination** features combine microwave cooking and convection cooking to cook food.

- Always use uncovered glass or ceramic dishes when sensor combination cooking.
- Place the oven shelf on the upper supports when sensor combination cooking.

POPCORN

1

(less time)

9

(more time)

Use only with prepackaged microwave popcorn weighing 1.75 to 3.5 ounces.

Sensor Cook Popcorn

NOTE: Do not use the metal shelf when cooking popcorn.

To use the **Sensor Cook Popcorn** feature:

- 1 Follow package instructions, using **Time Cook** if the package is less than 1.75 ounces or larger than 3.5 ounces. Place the package of popcorn in the center of the microwave.
- 2 Press **Sensor Cook POPCORN**. The oven starts immediately.

If you open the door while **POPCORN** is displayed, **SENSOR ERROR** will appear. Close the door, press **CLEAR/OFF** and begin again.

How to Adjust the Popcorn Program to Provide a Shorter or Longer Cook Time

If you find that the brand of popcorn you use underpops or overcooks consistently, you can add or subtract 20—30 seconds to the automatic popping time.

To add time:

After pressing **Sensor Cook POPCORN**, press **9** immediately after the oven starts for an extra 20 seconds. Press **9** again to add another 10 seconds (total 30 seconds additional time).

To subtract time:

After pressing **Sensor Cook POPCORN**, press **1** immediately after the oven starts for 20 seconds less cooking time. Press **1** again to reduce cooking time another 10 seconds (total 30 seconds less time).

BEVERAGE

Sensor Cook Beverage

Press **Sensor Cook BEVERAGE** to heat a cup of coffee or other beverage.

Drinks heated with the Sensor Cook Beverage feature may be very hot. Remove the container with care.

About the sensor features.

REHEAT

How to Change the Automatic Settings

To reduce time by 10%:
Press **1** after pressing **REHEAT**.

To add 10% to cooking time:
Press **9** after pressing **REHEAT**.

Sensor Cook Reheat

NOTE: Do not use the metal shelf with Sensor Cook Reheat.

The **Sensor Cook Reheat** feature reheats single servings of previously cooked foods or a plate of leftovers.

- 1 Place covered food in the oven. Press **Sensor Cook REHEAT**. The oven starts immediately.
- 2 The oven signals when steam is sensed and the time remaining begins counting down.

Do not open the oven door until time is counting down. If the door is opened, close it and press **START** immediately.

After removing food from the oven, stir, if possible, to even out the temperature. If the food is not hot enough, use Time Cook to reheat for more time. Reheated foods may have wide variations in temperature. Some areas may be extremely hot.

Some Foods Not Recommended for Use With Sensor Cook Reheat

It is best to use **Time Cook** for these foods:

- Bread products.
- Foods that must be reheated uncovered.
- Foods that need to be stirred or rotated.
- Foods calling for a dry look or crisp surface after reheating.

FRESH
VEG

FROZEN
VEG

CANNED
VEG

How to Change the Automatic Settings (Fresh Vegetable only)

To reduce time by 10%:
Press **1** after pressing **FRESH VEG**.

To add 10% to cooking time:
Press **9** after pressing **FRESH VEG**.

Sensor Cook Vegetable

NOTE: Do not use the metal shelf with the Sensor Cook Vegetable features.

Use the **Sensor Cook Vegetable** features to cook 4–16 ounces of fresh, frozen or canned vegetables.

- 1 For fresh vegetables, add 2 tablespoons of water per serving. For frozen vegetables, follow package instructions for adding water. Cover with lid or plastic wrap. Place vegetables in the oven.
- 2 Press the appropriate **Sensor Cook Vegetable** pad. The oven starts immediately. The oven signals when steam is sensed and time remaining is counting down.

Do not open the oven door until time is counting down. If the door is opened, close it and press **START** immediately. If food is not done enough, use **Time Cook** to cook for more time.



CHICKEN



**START
PAUSE**

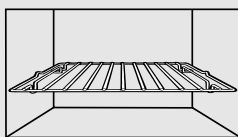

Place shelf on upper supports when sensor combination cooking.

Sensor Combination Chicken

Sensor Combination Chicken combines microwave cooking and convection cooking to cook 1–8 pieces of chicken.

- 1** Place chicken in a glass or ceramic dish. **Do not cover.** Place the dish on the oven shelf.
- 2** Press **Sensor Combination CHICKEN.**
- 3** Press **START.**

The oven signals when steam is sensed and time remaining begins counting down.

Do not open the oven door until time is counting down. If the door is opened, close it and press **START** immediately. If food is not done enough, use **Time Cook** to cook for more time.



FISH



**START
PAUSE**

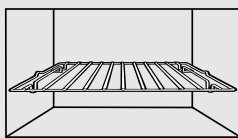

Place shelf on upper supports when sensor combination cooking.

Sensor Combination Fish

Use **Sensor Combination Fish** to combination cook 4–16 ounces of fish.

- 1** Place fish in a glass or ceramic dish. **Do not cover.** Place the dish on the oven shelf.
- 2** Press **Sensor Combination FISH.**
- 3** Press **START.**

The oven signals when steam is sensed and time remaining begins counting down.

Do not open the oven door until time is counting down. If the door is opened, close it and press **START** immediately. If food is not done enough, use **Time Cook** to cook for more time.

About the sensor features.

**BAKED
POTATO**

**START
PAUSE**

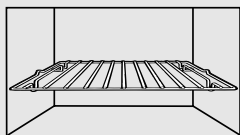

Place shelf on upper supports when sensor combination cooking.

Sensor Combination Baked Potato

The **Sensor Combination Baked Potato** feature combination cooks 1/2–2 lbs. of potatoes.

- 1 Pierce skin with fork and cluster potatoes in the center of the oven shelf.
- 2 Press **Sensor Combination BAKED POTATO**.
- 3 Press **START**.

The oven signals when steam is sensed and time remaining begins counting down.

Do not open the oven door until time is counting down. If the door is opened, close it and press **START** immediately. If food is not done enough, use **Time Cook** to cook for more time.

About the other features.

HELP

Help

The **HELP** pad displays feature information and helpful hints. Press **HELP**, then select a feature pad.

Cooking Complete Reminder

To remind you that you have food in the oven, the oven will display **FOOD IS READY** and beep once a minute until you either open the oven door or press **CLEAR/OFF**.



Shelf

- Never use the shelf for microwave-only cooking. Remove the shelf from the oven when microwave-only cooking.
- Always place the shelf on the floor of the oven for convection and combination cooking.
- Always place the shelf on the upper supports when sensor combination cooking or convection broiling.
- Use potholders when handling the shelf and cookware. They will be hot.
- Do not use the broiler pan or spatter shield while microwaving.

Clock

Press to enter the time of day or to check the time of day while microwaving.

- 1 Press **CLOCK**.
- 2 Enter time of day.
- 3 Select AM or PM.
- 4 Press **START** or **CLOCK**.

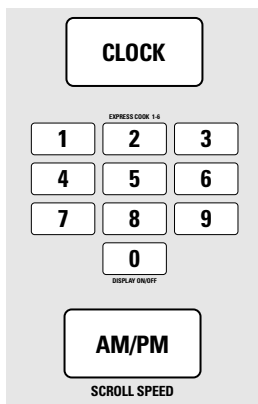

Scroll Speed

The scroll speed of the display can be changed. Press and hold the **AM/PM** pad about 3 seconds to bring up the display. Select 1–5 for slow to fast scroll speed.

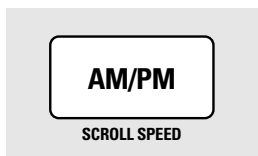

Display On/Off

To turn the clock display off, press and hold **0** for about three seconds.

To redisplay the clock, repeat.

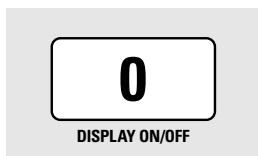

About the other features.

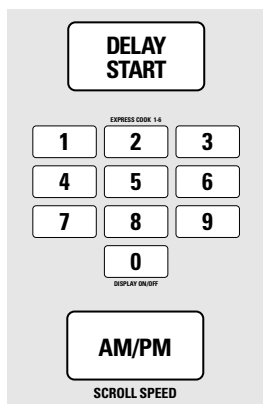

Delay Start

Delay Start allows you to set the microwave to delay cooking up to 24 hours.

- 1 Press **DELAY START**.
- 2 Enter the time you want the oven to start. (Be sure the microwave clock shows the correct time of day.)
- 3 Select AM or PM.
- 4 Select any combination of **Defrost Auto/Time**, **Time Cook I & II**, **Temp Cook**, a **Combination** function or a **Convection** function.
- 5 Press **START**.

The **Delay Start** time will be displayed plus **DS**. The oven will automatically start at the delayed time.

The time of day may be displayed by pressing **CLOCK**.

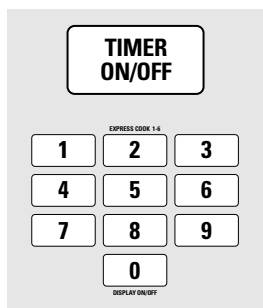

Timer On/Off

Timer On/Off operates as a minute timer and can be used at any time, even when the oven is operating.

- 1 Press **TIMER ON/OFF**.
- 2 Enter time you want to count down.
- 3 Press **TIMER ON/OFF** to start.

When time is up, the oven will signal. To turn off the timer signal, press **TIMER ON/OFF**.

NOTE: The timer indicator will be lit while the timer is operating.



Start/Pause

In addition to starting many functions, **START/PAUSE** allows you to stop cooking without opening the door or clearing the display.



REMINDER

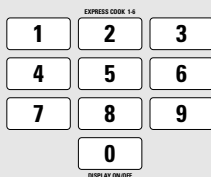

AM/PM

SCROLL SPEED

Reminder

The **Reminder** feature can be used like an alarm clock and can be used at any time, even when the oven is operating. The **Reminder** time can be set up to 24 hours later.

- 1 Press **REMINDER**.
- 2 Enter the time you want the oven to remind you. (Be sure the microwave clock shows the correct time of day.)
- 3 Select AM or PM.
- 4 Press **REMINDER**. When **Reminder** signal occurs, press **REMINDER** to turn it off. The **Reminder** time may be displayed by pressing **REMINDER**.

NOTE: The **REM** indicator will remain lit to show that the **Reminder** is set. To clear the **Reminder** before it occurs, press **REMINDER**, then **0**. The **REM** indicator will no longer be lit.



CLEAR
OFF

Child Lock-Out

You may lock the control panel to prevent the microwave from being accidentally started or used by children.

To lock or unlock the controls, press and hold **CLEAR/OFF** for about three seconds. When the control panel is locked, an **L** will be displayed to the extreme right.



VENT FAN

Vent Fan

The vent fan removes steam and other vapors from surface cooking.

Press **VENT FAN** once for high fan speed, twice for low fan speed or a third time to turn the fan off.

Automatic Fan

An automatic fan feature protects the microwave from too much heat rising from the cooktop below it. It automatically turns on at low speed if it senses too much heat.

If you have turned the fan on you may find that you cannot turn it off. The fan will automatically turn off when the internal parts are cool. It may stay on for 30 minutes or more after the cooktop and microwave controls are turned off.

About the other features.

SURFACE LIGHT

Surface Light

Press **SURFACE LIGHT** once for bright light, twice for the night light or three times to turn the light off.

SOUND LEVEL

Sound Level

The beeper sound level can be adjusted. Press **SOUND LEVEL**. Choose 0–3 for mute to loud.

AUTO NIGHT LIGHT

Auto Night Light

You can set the night light to turn on and off automatically at any time you want.



- 1 Press **AUTO NIGHT LIGHT**.
- 2 Enter the time you want the light to turn on. Select AM or PM.
- 3 Press **AUTO NIGHT LIGHT** again and enter the time you want the light to turn off. Select AM or PM.
- 4 Press **AUTO NIGHT LIGHT**.

NITE will stay lit to remind you that the feature is set. You can review the **Auto Night Light** settings by pressing **AUTO NIGHT LIGHT**.

To erase your settings and turn off the automatic feature, press **AUTO NIGHT LIGHT**, then **0**.

Microwave terms.

Term	Definition
Arcing	<p>Arcing is the microwave term for sparks in the oven. Arcing is caused by:</p> <ul style="list-style-type: none">■ the temperature probe staying in the oven but not inserted in the food.■ the metal shelf being installed incorrectly and touching the microwave walls.■ metal or foil touching the side of the oven.■ foil that is not molded to food (upturned edges act like antennas).■ metal such as twist-ties, poultry pins, gold-rimmed dishes.■ recycled paper towels containing small metal pieces.
Covering	<p>Covers hold in moisture, allow for more even heating and reduce cooking time. Venting plastic wrap or covering with wax paper allows excess steam to escape.</p>
Shielding	<p>In a regular oven, you shield chicken breasts or baked foods to prevent over-browning. When microwaving, you use small strips of foil to shield thin parts, such as the tips of wings and legs on poultry, which would cook before larger parts.</p>
Standing Time	<p>When you cook with regular ovens, foods such as roasts or cakes are allowed to stand to finish cooking or to set. Standing time is especially important in microwave cooking. Note that a microwaved cake is not placed on a cooling rack.</p>
Venting	<p>After covering a dish with plastic wrap, you vent the plastic wrap by turning back one corner so excess steam can escape.</p>

Care and cleaning of the microwave oven.



Helpful Hints

Open the oven door a few minutes after cooking to air out the inside. An occasional thorough wiping with a solution of baking soda and water keeps the inside fresh.

Be certain the power is off before cleaning any part of this oven.

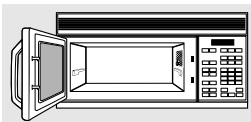

How to Clean the Inside

Walls, Floor, Inside Window, Metal and Plastic Parts on the Door

Some spatters can be removed with a paper towel, others may require a damp cloth. Remove greasy spatters with a sudsy cloth, then rinse with a damp cloth. Do not use abrasive cleaners or sharp utensils on oven walls.

Never use a commercial oven cleaner on any part of your microwave.

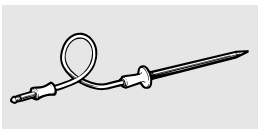

Temperature Probe

Clean immediately after using. To clean, wipe with sudsy cloth, then rub lightly with plastic scouring ball if necessary. Rinse and dry. The probe can also be washed in the dishwasher.

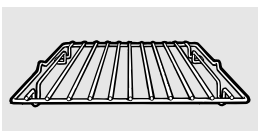

Shelf

Clean with mild soap and water or in the dishwasher.

Do not clean in a self-cleaning oven.

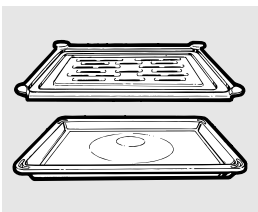

Broiler Pan (Spatter Shield and Drip Pan)

Remove spatter shield from drip pan. Carefully pour grease from drip pan into proper container. Clean immediately after using. If necessary, scour with a soap-filled or plastic scouring pad in hot, soapy water. If food has burned on, sprinkle spatter shield while hot with detergent and cover with wet paper towels or a dish cloth to soak loose burned-on foods. The broiler pan can also be washed in the dishwasher.

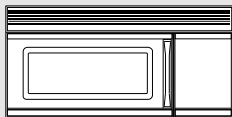

How to Clean the Outside

Do not use cleaners containing ammonia or alcohol on the microwave oven. Ammonia or alcohol can damage the appearance of the microwave.

Case

Clean the outside of the microwave with a sudsy cloth. Rinse and then dry. Wipe the window clean with a damp cloth.

Control Panel and Door

Wipe with a damp cloth. Dry thoroughly. Do not use cleaning sprays, large amounts of soap and water, abrasives or sharp objects on the panel—they can damage it. Some paper towels can also scratch the control panel.

Door Surface

It's important to keep the area clean where the door seals against the microwave. Use only mild, non-abrasive detergents applied with a clean sponge or soft cloth. Rinse well.

Stainless Steel (on some models)

To clean the outside surface and door glass, use hot soapy water on a damp cloth. Wipe off any soap residue and dry with a soft cloth to prevent streaks. Do not use steel wool pads or other abrasive cleaners. They will scratch the surface.

Bottom

Clean off the grease and dust on the bottom often. Use a solution of warm water and detergent.

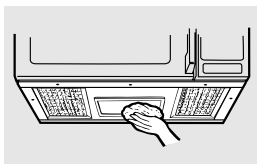

About light bulb replacement.

Cooktop Light/Night Light

- 1 To replace combination cooktop light/night light, **first disconnect the power at the main fuse or circuit breaker panel or pull the plug.**
- 2 Remove the screw on the right side of the light compartment cover and lower the cover until it stops.
- 3 Be sure the bulb(s) to be replaced are cool before removing. Break the adhesive seal by gently unscrewing the bulb(s).

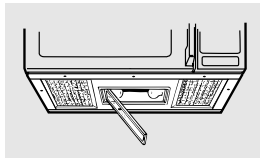
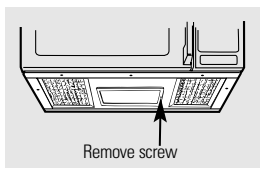

Replace with 40-watt incandescent bulbs. Order WB02X4253 from your GE supplier. High-intensity 40-watt bulbs (40S11N/1), available in supermarkets and hardware stores, may also be used for replacements.

- 4 Raise light compartment cover and replace the screw. Connect electrical power to the oven.

Oven Light

- 1 To replace the oven light, **first disconnect the power at the main fuse or circuit breaker panel or pull the plug.**
- 2 Remove the top grille by taking out the screw that holds it in place.
- 3 Next, remove the single screw located above the door near the center of the oven that secures the light housing.

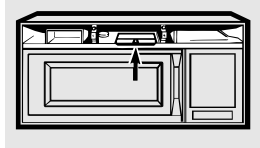
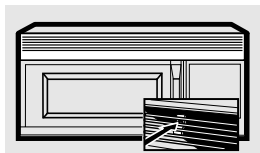

Replace the burned-out bulb with a 40-watt incandescent bulb (WB02X4253), available from your GE supplier.

About the exhaust feature.

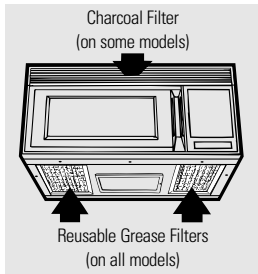

The Vent Fan

The vent fan has 2 metal reusable grease filters.

Models that recirculate air back into the room also use a charcoal filter.

Reusable Grease Filters

The metal filters trap grease released by foods on the cooktop. They also prevent flames from foods on the cooktop from damaging the inside of the microwave.

For this reason, the filters must ALWAYS be in place when the hood is used. The grease filters should be cleaned once a month, or as needed.

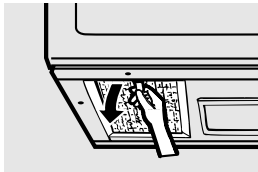

Removing and Cleaning the Filter

To remove, slide it to the rear using the tab. Pull it down and out.

To clean the grease filter, soak it and then swish it around in hot water and detergent. Don't use ammonia or ammonia products because they will darken the metal. Light brushing can be used to remove embedded dirt.

Rinse, shake and let it dry before replacing.

To replace, slide the filter in the frame slot on the back of the opening. Pull up and to the front to lock into place.

About the exhaust feature.

Charcoal Filter (on some models)

The charcoal filter cannot be cleaned. It must be replaced. Order Part No. WB02X4267 from your GE supplier.

If the model is not vented to the outside, the air will be recirculated through a disposable charcoal filter that helps remove smoke and odors.

The charcoal filter should be replaced when it is noticeably dirty or discolored (usually after 6 to 12 months, depending on hood usage).

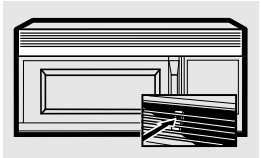

Remove 2 grille screws to remove the grille.

To Remove Charcoal Filter

To remove the charcoal filter, **first disconnect power at the main fuse or circuit breaker panel or pull the plug.**

Remove the top grille by removing the 2 screws that hold it in place. Slide the filter towards the front of the oven and remove it.

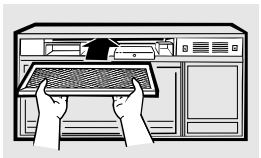

To Install Charcoal Filter

To install a new filter, remove plastic and other outer wrapping from the new filter.

Insert the filter into the top opening of the oven as shown. It will rest at an angle on 2 side support tabs and in front of the right rear tab. Replace the grille and 2 screws.

Before you call for service...



Troubleshooting Tips

Save time and money! Review the charts on the following pages first and you may not need to call for service.

Problem	Possible Causes	What To Do
Oven will not start	A fuse in your home may be blown or the circuit breaker tripped.	<ul style="list-style-type: none"> • Replace fuse or reset circuit breaker.
	Power surge.	<ul style="list-style-type: none"> • Unplug the microwave oven, then plug it back in.
	Plug not fully inserted into wall outlet.	<ul style="list-style-type: none"> • Make sure the 3-prong plug on the oven is fully inserted into wall outlet.
Control panel lighted, yet oven will not start	Door not securely closed.	<ul style="list-style-type: none"> • Open the door and close securely.
	START pad not pressed after entering cooking selection.	<ul style="list-style-type: none"> • Press START.
	Another selection entered already in oven and CLEAR/OFF pad not pressed to cancel it.	<ul style="list-style-type: none"> • Press CLEAR/OFF.
	Cooking time not entered after pressing TIME COOK .	<ul style="list-style-type: none"> • Make sure you have entered cooking time after pressing TIME COOK.
	CLEAR/OFF was pressed accidentally.	<ul style="list-style-type: none"> • Reset cooking program and press START.
	Food weight not entered after selecting Auto Defrost .	<ul style="list-style-type: none"> • Make sure you have entered food weight after selecting Auto Defrost.
"PLEASE INSERT PROBE" appears on display	Probe has been forgotten or not inserted properly.	<ul style="list-style-type: none"> • Insert the probe properly into the wall receptacle.
"BAD PROBE" appears on display	The probe has not been completely inserted into the wall receptacle.	<ul style="list-style-type: none"> • Insert the probe properly into the wall receptacle.
	The probe is defective.	<ul style="list-style-type: none"> • Replace the probe.
Floor of the oven is warm, even when the oven has not been used	The cooktop light is located below the oven floor. When the light is on, the heat it produces may make the oven floor get warm.	<ul style="list-style-type: none"> • This is normal.

Before you call for service...

Problem	Possible Causes	What To Do
"SENSOR ERROR" appears on display	When using a Sensor feature, the door was opened before steam could be detected.	<ul style="list-style-type: none"> Do not open the door until steam is sensed and time is shown counting down on display.
	Steam was not detected in maximum amount of time.	<ul style="list-style-type: none"> Use Time Cook to cook for more time.
"LOCKED" appears on display	The control has been locked. (When the control panel is locked an L will be displayed.)	<ul style="list-style-type: none"> Press and hold CLEAR/OFF for about 3 seconds to unlock the control.
"HOT—OVEN IS HOT" appears on display	The temperature inside the oven is greater than 200°F.	<ul style="list-style-type: none"> This is normal.
	One of the sensor cooking pads was pressed when the temperature inside the oven was greater than 200°F.	<ul style="list-style-type: none"> These features will not operate when the oven is hot.
You hear an unusual, low-tone beep	You have tried to start the Reminder without a valid time of day.	<ul style="list-style-type: none"> Start over and enter a valid time of day.
	You have tried to start the Auto Night Light without a valid time of day entered for the on-time and off-time.	<ul style="list-style-type: none"> Start over and enter a valid time of day.
	You have tried to change the power level when it is not allowed.	<ul style="list-style-type: none"> Many of the oven's features are preset and cannot be changed.
Food amount too large for Sensor Cook Reheat	Sensor Cook Reheat is for single servings of recommended foods.	<ul style="list-style-type: none"> Use Time Cook for large amounts of food.

Things That Are Normal With Your Microwave Oven

- Steam or vapor escaping from around the door.
- Light reflection around door or outer case.
- Dimming oven light and change in the blower sound at power levels other than high.
- Dull thumping sound while oven is operating.
- TV/radio interference might be noticed while using the microwave. Similar to the interference caused by other small appliances, it does not indicate a problem with the microwave. Plug the microwave into a different electrical circuit, move the radio or TV as far away from the microwave as possible, or check the position and signal of the TV/radio antenna.

GE Microwave Oven Warranty.



All warranty service provided by our Factory Service Centers, or an authorized Customer Care® technician. To schedule service, on-line, 24 hours a day, visit us at GEAppliances.com, or call 800.GE.CARES (800.432.2737).

Staple your receipt here. Proof of the original purchase date is needed to obtain service under the warranty.

For The Period Of:

GE Will Replace:

One Year

From the date of the original purchase

Any part of the microwave oven which fails due to a defect in materials or workmanship. During this **full one-year warranty**, GE will also provide, **free of charge**, all parts and service labor to repair or replace the defective part.

Ten Years

For the second through the tenth year from the date of original purchase

The magnetron tube, if the magnetron tube fails due to a defect in materials or workmanship. During this **additional nine-year limited warranty**, you will be responsible for any labor or in-home service costs.

What GE Will Not Cover:

- Service trips to your home to teach you how to use the product.
- Improper installation.
- Failure of the product if it is abused, misused, or used for other than the intended purpose or used commercially.
- Replacement of house fuses or resetting of circuit breakers.
- Damage to the product caused by accident, fire, floods or acts of God.
- Incidental or consequential damage caused by possible defects with this appliance.

This warranty is extended to the original purchaser and any succeeding owner for products purchased for ordinary home use within the USA. In Alaska, the warranty excludes the cost of shipping or service calls to your home.

Some states do not allow the exclusion or limitation of incidental or consequential damages, so the above limitation or exclusion may not apply to you. This warranty gives you specific legal rights, and you may also have other rights which vary from state to state. To know what your legal rights are, consult your local or state consumer affairs office or your state's Attorney General.

Warrantor: General Electric Company, Louisville, KY 40225

Consumer Support.



GE Appliances Website

GEAppliances.com

Have a question or need assistance with your appliance? Try the GE Appliances Website 24 hours a day, any day of the year! For greater convenience and faster service, you can now download Owner's Manuals, order parts, catalogs, or even schedule service on-line. You can also "Ask Our Team of Experts"[™] your questions, and so much more...



Schedule Service

GEAppliances.com

Expert GE repair service is only one step away from your door. Get on-line and schedule your service at your convenience 24 hours any day of the year! Or call 800.GE.CARES (800.432.2737) during normal business hours.



Real Life Design Studio

GEAppliances.com

GE supports the Universal Design concept—products, services and environments that can be used by people of all ages, sizes and capabilities. We recognize the need to design for a wide range of physical and mental abilities and impairments. For details of GE's Universal Design applications, including kitchen design ideas for people with disabilities, check out our Website today. For the hearing impaired, please call 800.TDD.GEAC (800.833.4322).



Extended Warranties

GEAppliances.com

Purchase a GE extended warranty and learn about special discounts that are available while your warranty is still in effect. You can purchase it on-line anytime, or call 800.626.2224 during normal business hours. GE Consumer Home Services will still be there after your warranty expires.



Parts and Accessories

GEAppliances.com

Individuals qualified to service their own appliances can have parts or accessories sent directly to their homes (VISA, MasterCard and Discover cards are accepted). Order on-line today, 24 hours every day or by phone at 800.626.2002 during normal business hours.

Instructions contained in this manual cover procedures to be performed by any user. Other servicing generally should be referred to qualified service personnel. Caution must be exercised, since improper servicing may cause unsafe operation.



Contact Us

GEAppliances.com

If you are not satisfied with the service you receive from GE, contact us on our Website with all the details including your phone number, or write to:

General Manager, Customer Relations
GE Appliances, Appliance Park
Louisville, KY 40225



Register Your Appliance

GEAppliances.com

Register your new appliance on-line—at your convenience! Timely product registration will allow for enhanced communication and prompt service under the terms of your warranty, should the need arise. You may also mail in the pre-printed registration card included in the packing material.