

GTR 200/GTR 200B

COM Transceiver Installation Manual



© 2020
Garmin Ltd. or its subsidiaries
All Rights Reserved

Except as expressly provided herein, no part of this manual may be reproduced, copied, transmitted, disseminated, downloaded or stored in any storage medium, for any purpose without the express prior written consent of Garmin. Garmin hereby grants permission to download a single copy of this manual and of any revision to this manual onto a hard drive or other electronic storage medium to be viewed and to print one copy of this manual or of any revision hereto, provided that such electronic or printed copy of this manual or revision must contain the complete text of this copyright notice and provided further that any unauthorized commercial distribution of this manual or any revision hereto is strictly prohibited.

Garmin International, Inc.
1200 E. 151st Street
Olathe, KS 66062 USA
www.garmin.com

Garmin (Europe) Ltd.
Liberty House, Hounslow Business Park
Southampton, Hampshire SO40 9LR U.K.

Garmin AT, Inc.
2345 Turner Rd., SE
Salem, OR 97302 USA

RECORD OF REVISIONS

Revision	Revision Date	Description
K	06/03/19	Added LEMO connector diagram
L	06/14/19	Updated interconnect drawings
M	10/15/19	Added various updates to Section 3 Installation Procedures
N	01/17/20	Added PMA unit info
P	12/21/20	Corrected Figure D-2

AVIATION LIMITED WARRANTY

GTR 200/200B warranty information is available at garmin.com/aviationwarranty.

CURRENT REVISION DESCRIPTION

Revision	Page Number(s)	Section Number	Description of Change
P	D-2	Appdx D	Removed extra ground symbol from Copilot Headset shield lines in Figure D-2

INFORMATION SUBJECT TO EXPORT CONTROL LAWS

This document may contain information which is subject to the Export Administration Regulations ("EAR") issued by the United States Department of Commerce (15 CFR, Chapter VII, Subchapter C) and which may not be exported, released, or disclosed to foreign nationals inside or outside of the United States without first obtaining an export license. The preceding statement is required to be included on any and all reproductions in whole or in part of this manual.

The Bluetooth® word mark and logos are registered trademarks owned by Bluetooth SIG, Inc. and any use of such marks by Garmin is under license. Other trademarks and trade names are those of their respective owners.

DEFINITIONS OF WARNINGS, CAUTIONS, AND NOTES



WARNING

A warning means injury or death is possible if the instructions are not obeyed.



CAUTION

A caution means that damage to the equipment is possible.



NOTE

A note gives more information.



WARNING

This product, its packaging, and its components contain chemicals known to the State of California to cause cancer, birth defects, or reproductive harm. This Notice is being provided in accordance with California's Proposition 65. If you have any questions or would like additional information, please refer to our web site at www.garmin.com/prop65.



CAUTION

The front bezel, keypad, and display can be cleaned with a microfiber cloth or with a soft cotton cloth dampened with clean water. DO NOT use any chemical cleaning agents. Care should be taken to avoid scratching the surface of the display.

SOFTWARE LICENSE AGREEMENT

BY USING THE DEVICE, COMPONENT OR SYSTEM MANUFACTURED OR SOLD BY GARMIN (“THE GARMIN PRODUCT”), YOU AGREE TO BE BOUND BY THE TERMS AND CONDITIONS OF THE FOLLOWING SOFTWARE LICENSE AGREEMENT. PLEASE READ THIS AGREEMENT CAREFULLY. Garmin Ltd. and its subsidiaries (“Garmin”) grants you a limited license to use the software embedded in the Garmin Product (the “Software”) in binary executable form in the normal operation of the Garmin Product. Title, ownership rights, and intellectual property rights in and to the Software remain with Garmin and/or its third-party providers. You acknowledge that the Software is the property of Garmin and/or its third-party providers and is protected under the United States of America copyright laws and international copyright treaties. You further acknowledge that the structure, organization, and code of the Software are valuable trade secrets of Garmin and/or its third-party providers and that the Software in source code form remains a valuable trade secret of Garmin and/or its third-party providers. You agree not to reproduce, decompile, disassemble, modify, reverse assemble, reverse engineer, or reduce to human readable form the Software or any part thereof or create any derivative works based on the Software. You agree not to export or re-export the Software to any country in violation of the export control laws of the United States of America.

TABLE OF CONTENTS

PARAGRAPH	PAGE
Section 1 General Description	1-1
1.1 Introduction.....	1-1
1.2 Equipment Description	1-1
1.3 Technical Specifications	1-2
1.4 Certification	1-5
1.5 Reference Documents	1-5
 Section 2 Installation Overview	 2-1
2.1 Introduction.....	2-1
2.2 Unit Configurations	2-1
2.3 Available Accessories.....	2-1
2.4 Installation Considerations	2-2
2.5 Antenna Considerations.....	2-3
2.6 Mounting Considerations.....	2-5
2.7 Cabling and Wiring.....	2-5
2.8 Air Circulation and Cooling	2-7
2.9 Compass Safe Distance.....	2-7
 Section 3 Installation Procedures	 3-1
3.1 Unpacking the unit.....	3-1
3.2 Wiring Harness Installation	3-1
3.3 Backshell Assembly.....	3-2
3.4 Mounting Requirements	3-2
3.5 Antenna Installation and Connections	3-3
3.6 Post Installation Configuration and Checkout Procedures	3-4
3.7 Unit Software	3-20
3.8 Disabling Bluetooth®	3-23
3.9 Continued Airworthiness	3-23
 Section 4 Connector Pinout Information.....	 4-1
4.1 Pin Function List.....	4-1
4.2 Power	4-2
4.3 Lighting Bus	4-2
4.4 CAN Bus.....	4-3
4.5 Unit ID	4-3
4.6 Serial Data – RS-232	4-4
4.7 MIC Audio.....	4-4
4.8 Aux Mono Audio	4-5
4.9 Headset Audio.....	4-5
4.10 Music Inputs	4-5

PARAGRAPH	PAGE
4.11 Receiver Audio	4-6
4.12 Pilot/Copilot PTT Inputs.....	4-6
4.13 TX Interlock.....	4-6
4.14 Discrete Inputs	4-7
Appendix A Shield Block Connector Installation Instructions	A-1
A.1 Shield Block Installation Parts.....	A-1
A.2 Shield Termination Technique – Method A.1 (Standard)	A-3
A.3 Shield Termination Technique - Method A.2 (Daisy Chain)	A-7
A.4 Shield Termination – Method B.1 (Quick Term)	A-7
A.5 Shield Termination-Method B.2 (Daisy Chain-Quick Term).....	A-9
A.6 Daisy Chain between Methods A and B	A-10
A.7 Splicing Signal Wires	A-10
Appendix B Serial Interface Specifications.....	B-1
B.1 Electrical Interface	B-1
B.2 Message Formats.....	B-1
Appendix C Outline and Installation Drawings	C-1
Appendix D Interconnect Examples	D-1

LIST OF FIGURES

FIGURE	PAGE
Section 1 General Description	1-1
Section 2 Installation Overview	2-1
Figure 2-1 CAN Bus Configuration.....	2-6
Section 3 Installation Procedures	3-1
Figure 3-1 GTR 200/200B Front Panel	3-4
Figure 3-2 Configuration Mode Home Page	3-5
Figure 3-3 COM Setup Page.....	3-7
Figure 3-4 ICS Sidetone Selection.....	3-7
Figure 3-5 MON Swap Selection.....	3-8
Figure 3-6 Audio Setup Page (AUX and Music Disabled)	3-9
Figure 3-7 Audio Setup Page (AUX and Music Enabled).....	3-9
Figure 3-8 Softkey Setup Page	3-10
Figure 3-9 Discrete Setup Page	3-11
Figure 3-10 Lighting Setup Page	3-12
Figure 3-11 Lighting Graph.....	3-13
Figure 3-12 RS-232 Status Page.....	3-13
Figure 3-13 Headset Tests Page.....	3-14
Figure 3-14 COM Tests Page	3-15
Figure 3-15 Audio Tests Page	3-16
Figure 3-16 About Page.....	3-20
Figure 3-17 Software Update Page.....	3-20
Figure 3-18 Micro SD Insertion.....	3-21
Figure 3-19 Software Update Page - Scanning Card.....	3-21
Figure 3-20 Software Update Page - No Update Found.....	3-22
Figure 3-21 Software Update Page - Update Software?.....	3-22
Figure 3-22 Software Update Page - Preparing Update.....	3-22
Figure 3-23 Software Update Page - Unit Will Reboot.....	3-22
Section 4 Connector Pinout Information.....	4-1
Figure 4-1 J2001 Looking at rear of unit.....	4-1
Figure 4-2 CAN Bus Termination for GTR 200/200B.....	4-3
Appendix A Shield Block Connector Installation Instructions.....	A-1
Figure A-1 Shield Block Install onto a Backshell	A-2
Figure A-2 Method A.1 for Shield Termination.....	A-3
Figure A-3 Insulation/Contact Clearance	A-5
Figure A-4 Method A.2 (Daisy Chain) for Shield Termination	A-7

FIGURE		PAGE
Figure A-5	Method B.1 (Quick Term) for Shield Termination	A-8
Figure A-6	Method B.2 (Daisy Chain-Quick Term) for Shield Termination.....	A-9
Figure A-7	Daisy Chain between Methods A and B	A-10
Figure A-8	D-Sub Spliced Signal Wire illustration.....	A-11
 Appendix B Serial Interface Specifications		B-1
 Appendix C Outline and Installation Drawings		C-1
Figure C-1	GTR 200/200B Outline Drawing	C-1
Figure C-2	GTR 200/200B Assembly Drawing	C-2
Figure C-3	GTR 200/200B Installation Drawing	C-3
Figure C-4	GTR 200/200B Panel Cutout Drawing	C-4
 Appendix D Interconnect Examples		D-1
Figure D-1	GTR 200/200B Interconnect Example Notes	D-1
Figure D-2	GTR 200/200B- Power & Ground/Intercom/GDU 37X/46X CAN Bus Interconnect Example	D-2
Figure D-3	GTR 200/200B- Power & Ground/Intercom/GDU 37X RS-232 Interconnect Example	D-3
Figure D-4	GTR 200/200B- Power & Ground/GMA 240/GNS 430/aera 79X Interconnect Example	D-4
Figure D-5	GTR 200/200B- Mono Audio/Remote Mount Jack Interconnect Example.....	D-5
Figure D-6	GTR 200/200B CAN Bus Interconnect Drawing	D-6
Figure D-7	Dual GTR 200/200B200/200B GMA 240 Interconnect Drawing	D-7
Figure D-8	LEMO Jack Interconnect Drawing	D-8
Figure D-9	GTR 200/200B - J2001 Connector Layout	D-9

LIST OF TABLES

TABLE	PAGE
Section 1 General Description	1-1
Table 1-1 Available Units.....	1-1
Table 1-2 Physical Characteristics.....	1-2
Table 1-3 General Specifications.....	1-2
Table 1-4 Display Specifications.....	1-3
Table 1-5 COM Transmitter Specifications.....	1-3
Table 1-6 COM Receiver Specifications.....	1-4
Table 1-7 FCC Grant of Equipment Authorization.....	1-5
Table 1-8 Reference Documents.....	1-5
 Section 2 Installation Overview.....	 2-1
Table 2-1 Catalog Part Numbers.....	2-1
Table 2-2 Standard Kit Accessories.....	2-1
Table 2-3 Contents of Connector Kit (011-03240-00), see Figure C-2.....	2-2
Table 2-4 Optional Accessories.....	2-2
 Section 3 Installation Procedures.....	 3-1
Table 3-1 Recommended Crimp Tools (or Equivalent).....	3-1
Table 3-2 Socket Contact Part Numbers.....	3-1
Table 3-3 Configuration Default Settings.....	3-6
Table 3-4 COM Setup Page Selections.....	3-7
Table 3-5 Audio Setup Page Selections.....	3-9
Table 3-6 Softkey Setup Page Selections.....	3-10
Table 3-7 Discrete Setup Page Selections.....	3-11
Table 3-8 Lighting Setup Page Selections.....	3-12
Table 3-9 Audio Tests Source Selections.....	3-16
Table 3-10 Discrete Inputs.....	3-17
Table 3-11 TX Interlock Connections.....	3-18
 Section 4 Connector Pinout Information.....	 4-1
Table 4-1 J2001 Connector.....	4-1
 Appendix A Shield Block Connector Installation Instructions	 A-1
Table A-1 Parts not supplied for a Shield Block Installation (Figure A-1).....	A-1
Table A-2 Shielded Cable Preparations for Garmin Connectors.....	A-3
Table A-3 Shielded Cable Preparations – (Quick Term).....	A-9
 Appendix B Serial Interface Specifications	 B-1
 Appendix C Outline and Installation Drawings	 C-1
 Appendix D Interconnect Examples	 D-1

1 GENERAL DESCRIPTION

1.1 Introduction

This manual is intended to provide mechanical and electrical information for use in the planning and design of an installation of the GTR 200/200B into an aircraft. This manual is not a substitute for an approved airframe-specific maintenance manual, installation design drawing, or complete installation data package. Attempting to install equipment by reference to this manual alone and without first planning or designing an installation specific to your aircraft may compromise your safety and is not recommended.

1.2 Equipment Description

Table 1-1 Available Units

Model	Part Number	TX Power (Watt)	8.33 KHz Spacing	25 KHz Spacing
GTR 200 with Serial Number Prefix 2QQ	011-02980-00	10	N/A	Yes
GTR 200 with Serial Number Prefix 5JC	011-02980-10	10	N/A	Yes
GTR 200B with Serial Number Prefix 5JD	011-02980-20	10	N/A	Yes
GTR 200B FAA-PMA with Serial Number Prefix 5JD	011-02980-40	10	N/A	Yes



CAUTION

The GTR 200/200B has a display that is coated with a special anti-reflective coating that is very sensitive to waxes and abrasive cleaners. CLEANERS CONTAINING AMMONIA WILL HARM THE ANTI-REFLECTIVE COATING. It is very important to clean the display using a clean, lint-free cloth and an eyeglass lens cleaner that is specified as safe for anti-reflective coatings.



CAUTION

The use of ground-based cellular telephones while aircraft are airborne is prohibited by FCC rules. Due to potential interference with onboard systems, the use of ground-based cell phones while the aircraft is on the ground is subject to FAA regulation 14 CFR §91.21. FCC regulation 47 CFR §22.925 prohibits airborne operation of ground-based cellular telephones installed in or carried aboard aircraft. Ground-based cellular telephones must not be operated while aircraft are off the ground. When any aircraft leaves the ground, all ground-based cellular telephones on board that aircraft must be turned off. Ground-based cell phones that are on, even in a monitoring state, can disrupt GPS/SBAS performance.



NOTE

All screen shots used in this document are current at the time of publication. Screen shots are intended to provide visual reference only. All information depicted in screen shots, including software file names, versions, and part numbers, is subject to change and may not be up to date.

1.3 Technical Specifications

1.3.1 Physical Characteristics

Table 1-2 Physical Characteristics

Characteristics	Specifications
Bezel Height	1.35 in (34.29 mm)
Bezel Width	6.25 in (158.8 mm)
Rack Height (Dimple-to-Dimple)	1.375 in (34.93 mm)
Rack Width	6.30 in (160.02 mm)
Depth Behind Panel with Connectors (Measured from face of aircraft panel to rear of connector backshells)	9.39 in (238.51 mm)
GTR 200/200B Weight (Unit Only)	1.38 lbs (0.63 kg)
GTR 200/200B (Installed with rack and connectors)	1.95 lbs (0.88 kg)

1.3.2 General Specifications

Table 1-3 General Specifications

Characteristics	Specifications
Operating Temperature Range	-20°C to +55°C
Humidity	95% non-condensing
Altitude Range	-1,500 ft to 55,000 ft
Input Voltage Range	14/28 VDC
Current Draw* at 14 VDC	0.6 A, Typical when receiving 3.0 A, Typical when transmitting 7.50 A Maximum, 90% modulated into 3:1 VSWR and 11V power input voltage
Current Draw* at 28 VDC	0.30 A, Typical when receiving 1.40 A, Typical when transmitting 3.75 A Maximum, 90% modulated into 3:1 VSWR and 22V power input voltage
Bluetooth Connectivity (GTR 200B only)	Bluetooth 3.00 Compliant, allows music and cell phone calls. Bluetooth supports HFP (including HFP v1.6 Wide Band Speech mode), A2DP, and AVRCP. The GTR 200B stores 10 paired devices and overwrites the least recently connected device when a new device is paired. Only 1 Bluetooth connection allowed at one time.

*The specified current draw is with the display backlight set to 100%

1.3.3 Display

The display on the GTR is a sunlight readable LCD display.

Table 1-4 Display Specifications

Characteristics	Specifications
Display Size	Width: 3.46" (88.0mm) Height: 0.843" (21.4mm)
Active Area	Width: 2.95" (74.98mm) Height: 0.486" (12.36mm)
Resolution	200 x 33 pixels
Viewing Angle	Left: 45° Right: 45° Up: 10° Down: 30°

1.3.4 COM Specifications

The GTR 200/200B transmitter meets the requirements of RTCA DO-186B section 2.3 for a class 4 transmitter.

Table 1-5 COM Transmitter Specifications

Characteristics	Specifications
Microphone Input	Two inputs, standard carbon or dynamic mic with integrated preamp. The GTR 200/200B provides a 150 Ω AC input impedance and supplies the microphone with an 11 V bias through 470 Ω +/- 5%.
Modulation Capability	85% with 150 to 1500 mVRMS microphone input at 1000 Hz. Range can be extended from 20 mVrms to 2500 mVrms with mic gain adjustment.
Modulation	AM Double sided Emission Designator: 6K00A3E (118 - 136.975 MHz)
Frequency Range	118.000 to 136.975 MHz, 25 kHz channel spacing
Frequency Tolerance	+/-5 ppm from -20°C to +55°C
Output Power	10 Watts carrier minimum
Duty Cycle	20%
Carrier Noise Level	At least 35 dB (SNR).
Stuck Mic Time-Out	35 seconds time-out, reverts to receive
Demodulated Audio Distortion	Less than 25% distortion when the transmitter is at 85% modulation at 350 to 2500 Hz

The GTR 200/200B receiver meets the requirements of RTCA DO-186B section 2.2 for a class C receiver.

Table 1-6 COM Receiver Specifications

Characteristics	Specifications
Frequency Range	118.000 to 136.975 MHz, 25 kHz channel spacing
Headset Audio Output	60 mW minimum into a 150 Ω load
Audio Response	Less than 6 dB of variation between 350 and 2500 Hz.
Audio Distortion	Less than 25% at rated output power
Sensitivity	SINAD greater than 6 dB when the RF level is -107 dBm with 30% modulation
Squelch	Automatic squelch with manual override

1.3.5 License Requirements

The Telecommunications Act of 1996, effective February 8, 1996, provides the FCC discretion to eliminate radio station license requirements for aircraft and ships. GTR installations must comply with current transmitter licensing requirements. In the US, to find out the specific details on whether a particular installation is exempt from licensing, please visit the FCC web site <http://wireless.fcc.gov/aviation>. If an aircraft license is required, make application for a license on FCC form 404, Application for Aircraft Radio Station License. The FCC also has a fax-on-demand service to provide forms by fax. Outside the US, contact the responsible telecommunication authority. The GTR owner accepts all responsibility for obtaining the proper licensing before using the transceiver. The maximum transmitting power, modulation identification, and frequency band information may be required for licensing and are detailed in [Section 1.3.4](#).

1.3.6 Aircraft Radio

An aircraft radio station license is not required when operating in U.S. airspace, but may be required when operating internationally.

1.4 Certification

The GTR 200/200B does not have TSO authorization.

The GTR 200B Part Number 011-02980-40 has FAA-PMA

1.4.1 FCC Grant of Equipment Authorization

Table 1-7 FCC Grant of Equipment Authorization

Model	FCC ID	IC ID
GTR 200	IPH-02115-01	1792A-02115-01
GTR 200B	IPH-02115-01	1792A-02115-01
	Contains QQQWT32I (for the Bluetooth module)	Contains 5123A-BGTWT32I (for the Bluetooth module)

1.5 Reference Documents

The following publications are sources of additional information for installing the GTR 200/200B. Before installing the GTR 200/200B, the installer should read all referenced materials along with the manual.

Table 1-8 Reference Documents

Part Number	Document
190-01553-01	GTR 200/200B Pilot's Guide

2 INSTALLATION OVERVIEW

2.1 Introduction

Careful planning and consideration of the suggestions in this section are required to achieve the desired performance and reliability from the GTR 200/200B. The guidance of FAA advisory circulars AC 43.13-1B and AC 43.13-2B, where applicable, may be found useful for making retro-fit installations that comply with FAA regulations.

2.2 Unit Configurations

Table 2-1 Catalog Part Numbers

Model	Catalog Part Number	Unit Only Part Number
GTR 200 Unit Only, Serial Number Prefix 2QQ	010-01087-00	011-02980-00
GTR 200 Standard, (includes items in Table 2-2) Serial Number Prefix 2QQ	010-01087-01	011-02980-00
GTR 200 Unit Only, Serial Number Prefix 5JC	010-01087-10	011-02980-10
GTR 200 Standard, (includes items in Table 2-2) Serial Number Prefix 5JC	010-01087-11	011-02980-10
GTR 200B, Serial Number Prefix 5JD	010-01087-20	011-02980-20
GTR 200B Standard, (includes items in Table 2-2) Serial Number Prefix 5JD	010-01087-21	011-02980-20
GTR 200B FAA-PMA, Serial Number Prefix 5JD	010-01087-40	011-02980-40
GTR 200B Standard FAA-PMA, Serial Number Prefix 5JD	010-01087-41	011-02980-40

2.3 Available Accessories

2.3.1 Standard Accessories

Table 2-2 Standard Kit Accessories

Item	Part Number
Connector Kit (see Table 2-3)	011-03240-00
Connector Kit FAA-PMA (see Table 2-3)	011-03240-01
Installation Rack (see Figure C-2)	115-01878-00
Installation Rack FAA-PMA (see Figure C-2)	115-01878-02 (ordered as 011-03240-10)

Table 2-3 Contents of Connector Kits (011-03240-00/-01), see [Figure C-2](#)

Item	Part Number	Quantity
Backshell w/Hardware, 37 pin	011-00950-03	1
Connector Plate	115-01879-00	1
Ring Terminal	117-00147-01	1
Single Coax Connector Plate Adapter	125-00165-00	1
Pan Head Phillips Screw 8-32 x .312	211-60209-09	6
Flat Head Phillips Screw 4-40 x .250	211-63234-08	4
Flat Head Phillips Screw 4-40 x .375	211-63234-10	4
Split Lock Washer, size 8	212-00018-04	6
Shoulder Washer	212-00022-00	1
Flat Washer #4	212-00024-04	1
Flat Washer, Inside Diameter 0.195", Outside Diameter 0.354"	212-20065-00	6
Alignment Pin, Shoulder #4-40	233-00087-00	1
Male/Female BNC Connector	330-00053-01	1
37 Pin D-Sub Crimp Socket Connector	330-00625-37	1
Crimp Socket Contact, Size 20, 20-24 AWG	336-00022-02	37

2.3.2 Optional Accessories

Table 2-4 Optional Accessories

Item	Part Number
4 GB Micro SD Card (w/SD adapter)	010-10683-05

2.4 Installation Considerations

2.4.1 COM Antenna

A COM Antenna that meets TSO-C37() and C38() or TSO-C169(), 50W, vertically polarized with coaxial cable is recommended but not provided.

2.4.2 Installation Materials

The GTR 200/200B is intended for use with the standard aviation accessories. The following items are required for installation, but not supplied:

- Wire (MIL-W-22759/16 or equivalent)
- Shielded Wire (MIL-C-27500 or equivalent)
- Hardware - #6-32 x 100° Flat Head SS Screw [(MS24693, AN507R or other approved fastener) (6 ea.)] and #6-32 Self-Locking Nut [MS21042 or other approved fastener (6 ea.)]
- Push/Pull (that can be manually reset) Circuit Breaker
- Tie Wraps or Lacing Cord
- Ring Terminals (for grounding)
- Coaxial Cable (RG-400, RG-142B or coaxial cable with 50 Ω impedance meeting applicable aviation regulations should be used.

2.5 Antenna Considerations

This section contains mounting location considerations for the antennas required for the GTR 200/200B. For mounting the COM antenna, refer to the aircraft manufacturer's data.

2.5.1 COM Antenna Location

The GTR 200/200B COM antenna should be well removed from all projections, engines and propellers. The ground plane surface directly below the antenna should be a flat plane over as large an area as possible (18 inch square, minimum). The antenna should be mounted a minimum of six feet from any DME or other COM antennas, and four feet from any ADF sense antennas. The COM antenna should also be mounted as far as practical from the ELT antenna. Some ELTs have exhibited re-radiation problems that cause interference with other radios, including GPS. This can happen when the COM (GTR 200/200B or any other COM) is transmitting on certain frequencies such as 121.15 or 121.175 MHz, which may cause the ELT output circuit to oscillate from the signal coming in on the ELT antenna coax.

If simultaneous use of two COM transceivers is desired (split-COM or simul-comm), the COM antennas should be spaced for maximum isolation. A configuration of one topside antenna and one bottom side antenna is recommended. The GTR 200/200B requires a transmit interlock.

Simultaneous COM performance varies significantly across installations and is affected by both the isolation between the COM antennas and the separation of the tuned frequencies. Each installation should be individually examined to determine the expected performance of simultaneous COM.



CAUTION

If the COM antennas are mounted less than six feet apart with a direct line of sight between the antennas the non-transmitting radio could be damaged when the other radio transmits. An example of direct line of sight is both antennas mounted on the bottom or top surface of the aircraft. For metallic aircraft one antenna should be mounted on the bottom close to the front and the other on the top of the aircraft close to the tail such that the aircraft structure is between the two antennas. For composite aircraft additional shielding may be needed between top and bottom mounted COM antennas.



NOTE

The GTR 200/200B COM antenna should be installed at least 20 cm from the front panel of the GTR 200/200B unit.



NOTE

Canadian installations are required to meet Industry Canada specifications for maximum radiation as documented in Radio Specifications Standard 102 (RSS-102). For more information about RF exposure and related Canadian regulatory compliance, contact:

*Manager, Radio Equipment Standards
Industry Canada
365 Laurier Avenue
Ottawa, Ontario
K1A 0C8*

In accordance with Canadian Radio Specifications Standard 102 (RSS 102), an RF safety separation distance of 26 cm from the antenna should be maintained for an RF field strength exposure to persons of less than the 10W/m² occupational safety limit.

Under Industry Canada regulations, this radio transmitter may only operate using an antenna of a type and maximum (or lesser) gain approved for the transmitter by Industry Canada. To reduce potential radio interference to other users, the antenna type and its gain should be so chosen that the equivalent isotropically radiated power (e.i.r.p.) is not more than that necessary for successful communication.

The GTR 200/200B has been approved by Industry Canada to operate with the antenna types listed below. Antenna types not included in this list, having a gain greater than the maximum gain indicated for that type, are strictly prohibited for use with this device.

A COM Antenna that meets TSO-C37() and C38() or TSO-C169(), 50W, vertically polarized. Maximum gain of 1 dBi with an impedance of 50 ohms.

2.5.2 Interference of GPS

On some installations, VHF COM transceivers, Emergency Locator Transmitter (ELT) antennas, and Direction Finder (DF) receiver antennas can re-radiate to the GPS antenna. Placement of the GPS antenna relative to a COM transceiver and COM antenna (including the GTR/ COM antenna), ELT antenna, and DF receiver antenna is critical.

Use the following guidelines, in addition to others in this document, when locating the GTR 200/200B and its antenna.

- Locate the GTR 200/200B as far as possible from all GPS antennas.
- Locate the COM antenna as far as possible from all GPS antennas.

If a COM is found to be radiating, the following can be done:

- Replace or clean VHF COM rack connector to ensure good coax ground.
- Place a grounding brace between the GTR 200/200B and ground.
- Shield the GTR 200/200B wiring harness.

2.6 Mounting Considerations

The GTR 200/200B is designed to mount in the avionics stack in the aircraft instrument panel within view and reach of the pilot. The primary unit location should minimize pilot head movement when transitioning between looking outside of the cockpit and viewing/operating the GTR 200/200B. The location should be such that the GTR 200/200B unit is not blocked by the glare shield on top, or by the throttles, control yoke, etc. on the bottom. If aircraft has a throw-over yoke, be sure the yoke does not interfere with the GTR 200/200B.

2.7 Cabling and Wiring

Refer to the interconnect examples in [Appendix D](#) for wire gauge guidance.

Use wire and cable meeting the applicable aviation regulation. When routing wire and cable, observe the following precautions:

- Keep as short and as direct as possible
- Avoid sharp bends
- Avoid routing near power sources (e.g. 400 Hz generators, trim motors, etc.) or near power for fluorescent lighting
- Do not route cable near high voltage sources



CAUTION

To avoid damage to the GTR 200/200B, take precautions to prevent Electro-Static Discharge (ESD) when handling the GTR 200/200B, connectors, and associated wiring. ESD damage can be prevented by touching an object that is of the same electrical potential as the GTR 200/200B before handling the GTR 200/200B itself.

2.7.1 Noise

As audio signals are routed to and from the GTR 200/200B (Headset, Microphone, Music, AUX), care must be taken to minimize effects from coupled interference and ground loops.

Interference can be coupled into interconnecting cables when they are routed near large AC electric fields, AC voltage sources, and pulse equipment (strobos, spark plugs, magnetos, EL displays, CRTs, etc). Interference can also couple into interconnecting cables by magnetic induction when they are routed near large AC current-carrying conductors or switched DC equipment (heaters, solenoids, fans, autopilot servos, etc).

Ground loops are created when there is more than one path in which return currents can flow, or when signal returns share the same path as large currents from other equipment. These large currents create differences in ground potential between various equipment operating in the aircraft. These differences in potential can produce an additive effect at audio signal inputs.

The GTR 200/200B audio inputs may detect the desired input signal plus an unwanted component injected by ground differentials, a common cause of alternator-related noise. This can be minimized by isolating all audio jacks from ground.

Terminating shields at just one end (single-point grounding) eliminates another potential ground loop injection point. The single-point grounding method is critical for the installation of various avionics that produce and process audio signals. Single-point, in this context, means that the various pieces of equipment share a single common ground connection back to the airframe.

Good aircraft electrical/charging system ground bonding is important.

The wiring diagrams and accompanying notes in this manual should be followed closely to minimize noise effects.

2.7.2 CAN Bus Considerations

The CAN (controller area network) bus (Figure 2-1) is an interface format used to establish communication between several LRUs in the G3X system. Each end of the CAN bus “backbone” must be terminated. Each node length (distance from CAN bus backbone to each LRU) must be 0.3 meter or less in length (keeping the node lengths as short as practicable is recommended). There is no minimum node length.

A GTR 200/200B can be connected in a G3X system that uses a GDU 37X or GDU 46X with CAN bus or RS232, the CAN bus is preferred.



NOTE

Use only two CAN bus terminations per installation (even if provided more than two from associated G3X installation kits). Using less than or more than two terminations (one at each end of the backbone) will make the CAN bus unusable or unreliable.

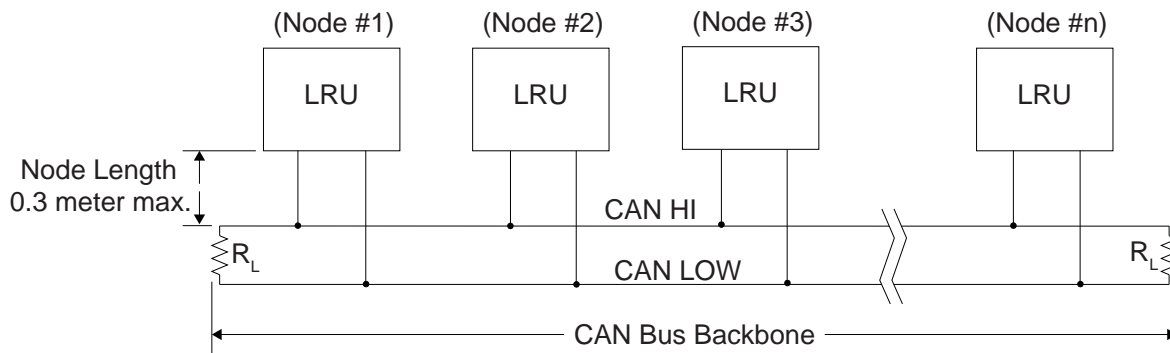

Figure 2-1 CAN Bus Configuration

The following items should be considered when installing/removing/replacing LRU’s on the CAN bus:

1. CAN bus node connections must be made on the connector of each LRU that connects to the CAN bus, do not tie CAN bus nodes from individual LRUs together into a single connection point.
2. Keep all node lengths as short as practicable, and allow only one ‘lengthy’ node if possible.



NOTE

The 120 Ω termination resistors described in the preceding paragraphs are “built-in” to the termination method shown in [Figure D-2](#). Do not install a separate “discrete” 120 Ω resistor to terminate the CAN bus.

2.8 Air Circulation and Cooling

The GTR 200/200B unit meets all requirements without external cooling. However, as with all electronic equipment, lower operating temperatures extends equipment life. Reducing the operating temperature by 15° to 20°C (27° to 36°F) reduces the mean time between failures (MTBF).

Units tightly packed in the avionics stack heat each other through radiation, convection, and sometimes by direct conduction. Even a single unit operates at a much higher temperature in still air than in moving air. Fans or some other means of moving the air around electronic equipment are usually a worthwhile investment.

2.9 Compass Safe Distance

After reconfiguring the avionics in the cockpit panel, if the unit is mounted less than 12 inches from the compass, recalibrate the compass and make the necessary changes for noting correction data.

3 INSTALLATION PROCEDURES

3.1 Unpacking the unit

Carefully unpack the equipment and make a visual inspection of the unit for evidence of damage incurred during shipment. If the unit is damaged, notify the carrier and file a claim. To justify a claim, save the original shipping container and all packing materials. Do not return the unit to Garmin until the carrier has authorized the claim.

Retain the original shipping containers for storage. If the original containers are not available, a separate cardboard container should be prepared that is large enough to accommodate sufficient packing material to prevent movement.

3.2 Wiring Harness Installation

Allow adequate space for installation of cables and connectors. The installer shall supply and fabricate all cables. All electrical connections to the GTR 200/200B are made through one 37-pin D-sub standard density connector (P2001) and one BNC connector for the antenna (P2002). [Section 4](#) defines the electrical characteristics of all input and output signals. Required connectors and associated hardware are supplied with the connector kit ([Table 2-3](#)).

See [Appendix D](#) for examples of interconnect wiring diagrams. Construct the actual harnesses in accordance with the aircraft manufacturer authorized interconnect standards. After the cable assemblies are made, route the wiring bundle as appropriate. Use cable ties to provide strain relief for the coax and cable assemblies.

The connector uses crimp contacts. Table 3-1 identifies crimp tools required to ensure consistent, reliable crimp contact connections for the D-sub connector P2001. Table 3-2 identifies the contacts used for P2001.



NOTE

Check wiring connections for errors before connecting to the GTR 200/200B. Incorrect wiring could cause internal component damage.

Table 3-1 Recommended Crimp Tools (or Equivalent)

Manufacturer	Hand Crimping Tool	20 – 24 AWG (P2001)	
		Positioner	Insertion/ Extraction Tool
Military P/N	M22520/2-01	M22520/2-08	M81969/1-02
Positronic	9507-0-0-0	9502-5-0-0	4711-2-0-0
AMP	601966-1	601966-5	91067-2
Daniels	AFM8	K13-1	M81969/1-02
Astro	61517	615724	M81969/1-02

Table 3-2 Socket Contact Part Numbers

Supplier	20-24 AWG Socket Contact Part Number
Garmin Part Number	336-00022-02
Military Part Number	M39029/63-368

3.3 Backshell Assembly

Refer to [Appendix A](#) for backshell and Shield Block ground assembly instructions.

3.4 Mounting Requirements

3.4.1 Rack Installation

Use the dimensions shown in [Appendix C](#) to prepare the mounting holes for the unit. You may also use the GTR 200/200B unit mounting rack itself as a template for drilling the mounting holes.

1. [Figure C-1](#) shows outline dimensions for the avionics rack for the unit. Install the rack in a rectangular hole (or gap between units) in the instrument panel per [Figure C-4](#). The lower-front lip of the rack should be flush with, or extend slightly beyond the finished face of the aircraft panel.



NOTE

If the front lip of the mounting rack is behind the surface of the aircraft panel, the unit connectors may not fully engage. See [Figure C-4](#) for more information. Ensure that no screw heads or other obstructions prevent the unit from fully engaging in the rack. Exercise caution when installing the rack into the instrument panel. Deformation of the rack may make it difficult to install and remove the unit.

2. Install the rack in the aircraft panel using six #6-32 flat head screws. The screws are inserted from the inside through the holes in the sides of the rack.
3. Follow the steps listed in [Figure C-3](#) to attach the backplate to the rack.

3.4.2 Unit Insertion and Removal

It may be necessary to insert the hex drive tool into the access hole and rotate the drive tool counterclockwise until it completely stops in order to ensure correct position of the retention mechanism prior to placing the unit in the rack. The unit is installed in the rack by sliding it straight in until it stops, about 3/8 inch short of the final position. A 3/32-inch hex drive tool is then inserted into the access hole at the bottom of the unit face. Rotate the hex tool clockwise while pressing on the bezel until the unit is firmly seated in the rack.

To remove the unit from the rack, insert the hex drive tool into the access hole on the unit face. Rotate counterclockwise until the unit is forced out about 3/8 inch and the hex drive tool completely stops. This will allow the unit to be freely pulled from the rack.

Be sure not to over tighten the unit into the rack. The application of hex drive tool torque exceeding 15 in-lbs can damage the locking mechanism.

3.5 Antenna Installation and Connections

The GTR 200/200B requires a standard 50 Ω vertically polarized antenna. Follow the antenna manufacturer's installation instructions for mounting the antenna.

The antenna should be mounted on a metal surface or a ground plane with a minimum area of 18 inches x 18 inches. Refer to [Section 2.5.1](#) for installation location considerations.

3.5.1 Antenna Coaxial Cable Installation

The antenna coax cable should be made of RG-142B, RG-400 or a comparable quality 50 Ω coax. Follow the BNC connector manufacturer's instructions for cable preparation/connector installation.

Check that there is ample space for the cabling and mating connectors. Avoid sharp bends in the antenna cable, and routing near aircraft control cables. Route the COM antenna cable as far as possible away from any GPS antenna cables.

Check for insertion loss and Voltage Standing Wave Ratio (VSWR). VSWR should be checked with an in-line type VSWR/wattmeter inserted in the coaxial transmission line between the transceiver and the antenna. The VSWR meter should be inserted as close to the transceiver as possible. When rack and harness buildup is performed in the shop, the coax termination may be provisioned by using a 6-inch in-line BNC connection. This would be an acceptable place to insert the VSWR meter. Any problem with the antenna installation is most likely seen as high reflected power. A VSWR of 3:1 may result in up to a 50% loss in transmit power. VSWR at the low, mid and high end of the tuning range should be less than 3:1, for best performance VSWR should be less than 2:1. A high VSWR decreases the amount of power radiated by the antenna and increases power supply current and heat dissipated by the radio when the radio is transmitting.

3.6 Post Installation Configuration and Checkout Procedures

3.6.1 System Configuration Overview

This section contains checks to ensure the system is properly installed and functioning correctly as well as instructions for configuring the GTR 200/200B to the specific installation. Follow the instructions in Section 3.6.2 through [Section 3.6.7.1](#) in order to complete all post installation configuration and checkout procedures.

3.6.2 Mounting, Wiring, and Power Checks

Verify that all cables are properly secured and shields are connected to the shield block of the connectors. Check the movement of the flight and engine controls to verify there is no interference between the cabling and control systems. Ensure that all wiring is installed as described in [Section 2.7](#).

Prior to powering up the unit, the wiring harness must be checked for proper connections to the aircraft systems and other avionics equipment. Point to point continuity must be checked to expose any faults such as shorting to ground. Any faults or discrepancies must be corrected before proceeding.

After accomplishing a continuity check, perform power and ground checks to verify proper power distribution to the GTR 200/200B. Any faults or discrepancies should be corrected at this time. Remove power from the aircraft upon completion of the harness checkout.

The GTR 200/200B can be installed after completion of the continuity and power checks. The GTR 200/200B should be installed into the rack and secured appropriately, as described in [Section 3.4.2](#). The GTR 200/200B must be connected to the wiring harness and antenna.

3.6.3 Configuration Mode

The configuration pages shown in this section reflect main software version 2.40 or later. Some differences in operation may be observed when comparing the information in this manual to later software versions. Refer to Figure 3-1 to identify knobs, buttons, and softkeys used in the configuration procedures.

Configuration mode is used to configure the unit settings for each specific installation. To access configuration mode, remove power from the unit. With the unit turned off, press and hold the SMALL Knob and apply power by turning the Power/Volume/Squelch Knob clockwise. Release the SMALL Knob when the display activates, the Config Mode Home page will be displayed ([Figure 3-2](#)).

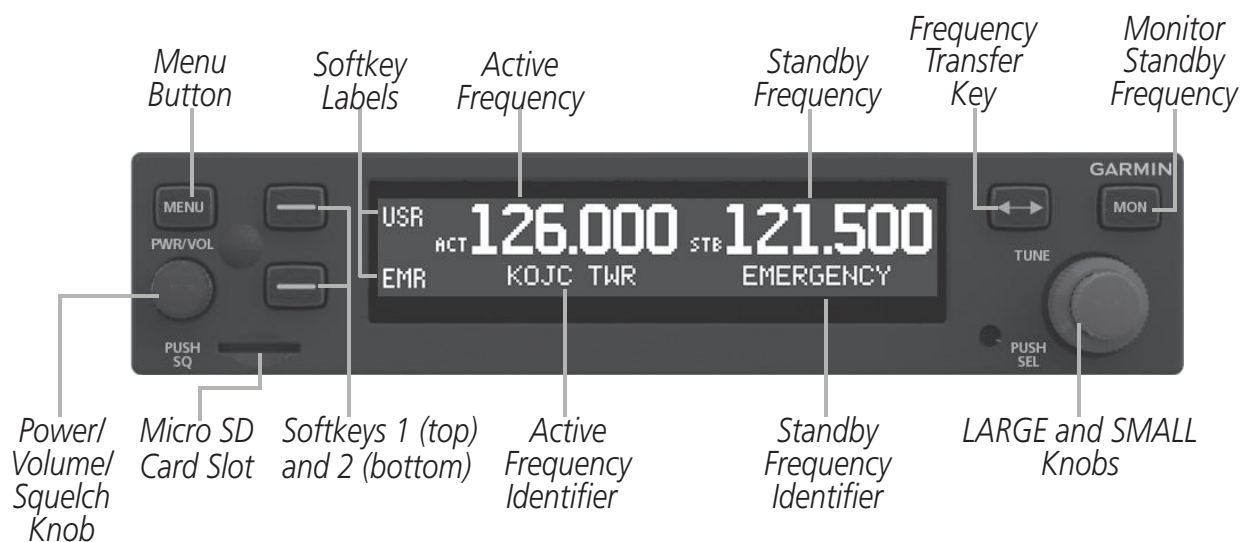

Figure 3-1 GTR 200/200B Front Panel

3.6.4 Configuration Pages

The first page displayed in configuration mode (see [Section 3.6.3](#)) is the Configuration Mode Home page (Figure 3-2). From the Configuration Mode Home page, turn the LARGE Knob to select the desired subpage then press the SMALL Knob to display the subpage.



Figure 3-2 Configuration Mode Home Page

There are eight subpages available in configuration mode, each of these subpages is described in the following sections:

- COM SETUP - See [Section 3.6.4.2](#)
- AUDIO SETUP - See [Section 3.6.4.3](#)
- SOFTKEY SETUP - See [Section 3.6.4.4](#)
- DISCRETE SETUP - See [Section 3.6.4.5](#)
- LIGHTING SETUP - See [Section 3.6.4.6](#)
- RS-232 STATUS - See [Section 3.6.4.7](#)
- HEADSET TESTS - See [Section 3.6.5.1](#)
- COM TESTS - See [Section 3.6.5.2](#)
- AUDIO TESTS - See [Section 3.6.5.3](#)

3.6.4.1 Default Settings

Table 3-3 lists the default values for the configuration mode settings.

Table 3-3 Configuration Default Settings

Page	Setting	Default	Note
COM SETUP	SIDETONE	5	
	MIC GAIN	5	
	RF SQLCH	0	
AUDIO SETUP	INTERCOM ENABLED	YES	
	RECEIVER OUT GAIN	100%	
	AUX 1 SQUELCH	30%	
	AUX 1 VOLUME	50%	
	AUX 1 MUTE (MUSIC)	NO	
	AUX 2 SQUELCH	30%	
	AUX 2 VOLUME	50%	
	AUX 2 MUTE (MUSIC)	NO	
PILOT ON RIGHT SIDE	NO		
SOFTKEY SETUP	KEY 1	USER LIST	
	KEY 2	TUNE EMERGENCY	
DISCRETE SETUP	DISC 1	PILOT ICS KEY	
	DISC 2	COPILOT ICS KEY	
LIGHTING SETUP	LIGHTING SOURCE	SENSOR	
	TIME CONSTANT	5.0/0.2	First value is photocell default; Second value is lighting bus default
	MIN INPUT LEVEL	10%/21%	
	MIN BRIGHTNESS	10%/10%	
	MAX INPUT LEVEL	90%/86%	N/A for photocell
	MAX BRIGHTNESS	100%	
	OFF THRESHOLD	21%	
	OFF HYSTERESIS	0.1%	
BUTTON OFFSET	10%		

3.6.4.2 COM Setup Page

The COM Setup page (Figure 3-3) allows the installer to configure various transmit and receive settings as listed in Table 3-4. For testing purposes, an “X” will appear in the appropriate TX, RX, and SQ checkboxes when the GTR 200/200B is transmitting, receiving, or the squelch is overridden or open (‘open’ squelch is defined as when the squelch is overridden and audio is heard).

Refer to [Section 3.6.4](#) to select the COM Setup Page. Use the LARGE Knob to scroll through the listed functions, then use the SMALL Knob to adjust the setting of the function. After the setting has been changed, turn the LARGE Knob to move the cursor to another function.



Figure 3-3 COM Setup Page

Table 3-4 COM Setup Page Selections

Selection	Description
Frequency (MHz)	Set frequency from 118-136 MHz.
Frequency (kHz)	Set frequency from 0-975 kHz in 25 kHz increments.
SIDETONE	<p>This setting controls the volume of the sidetone audio for the unit during PTT, and is adjusted to correct either low or high sidetone volume. Increasing the setting increases the sidetone volume. Sidetone can be set from 0 to 10, a setting of 5 (default) represents the factory calibration.</p> <p>Sidetone audio is routed to headset audio and to received audio out, and is generally output to an audio control panel.</p> <p>The Intercom Enable/Disable setting on the Audio Setup Page (see Table 3-5) affects the sidetone per the following:</p> <p><u>Intercom Enabled:</u></p> <p>Sidetone volume may also be linked to the ICS (intercom) volume. This is accomplished by selecting the Sidetone setting one turn counter clockwise from ‘00’ setting, ‘ICS’ will be displayed (Figure 3-4). Intercom volume is adjustable in normal mode (see Pilots Guide).</p>  <p>Figure 3-4 ICS Sidetone Selection</p> <p>Sidetone audio that is sent to the received audio output (see Receiver Out Gain setting in Table 3-5) is the same volume as sidetone audio sent to the headset.</p> <p><u>Intercom Disabled:</u></p> <p>Sidetone audio is only sent to received audio output (not to the headset).</p>

Table 3-4 COM Setup Page Selections

<p>MIC GAIN</p>	<p>Increasing or decreasing this setting, increases or decreases the transmit microphone gain respectively. Mic gain can be set from 0 to 10. A setting of 5 (default) represents the factory calibration, most headsets/microphones should work fine at this setting. Generally the mic gain setting should not be adjusted unless the pilot consistently gets reports that the transmitter sounds “weak”. Most often, this setting is adjusted to compensate for “weak” or low output microphones. The transmit sidetone volume is affected by the mic gain setting, so an adjustment of the sidetone setting may be needed after adjusting the mic gain setting.</p>
<p>RF SQLCH</p>	<p>Increasing this setting increases the signal level required to break squelch. Receiver squelch can be set from 0-10, a setting of 0 (default) represents the factory calibration.</p>
<p>MON SWAP</p>	<p>This setting affects how the monitor function acts when pressing the Frequency Transfer Key (in addition to swapping the Active and Standby frequencies). Setting to ON (Figure 3-5) will keep the Monitor feature ON when pressing the Frequency Transfer Key. Setting to OFF will turn off the Monitor feature when the Frequency Transfer Key is pressed</p> <div data-bbox="613 831 1243 940" data-label="Image"> <p>The screenshot shows a monochrome LCD display with the following text: 'COM SETUP' on the top left, '118.900' in the center, 'MIC GAIN 05' on the top right, and 'RF SQLCH 00' on the middle right. At the bottom, there is a row of controls: '←BACK', 'TX' with a square box, 'RX' with a square box, 'SQ' with a square box, 'MON SWAP' with a square box containing 'ON', and a vertical arrow key.</p> </div> <p style="text-align: center;">Figure 3-5 MON Swap Selection</p>

3.6.4.3 Audio Setup

The Audio Setup page (Figure 3-6, Figure 3-7) allows the installer to configure the various audio settings listed in Table 3-6.

Refer to [Section 3.6.4](#) to select the Audio Setup Page. Use the LARGE Knob to scroll through the listed functions, then use the SMALL Knob to adjust the setting of the function. After the setting has been changed, turn the LARGE Knob to move the cursor to another function.



Figure 3-6 Audio Setup Page (AUX and Music Disabled)



Figure 3-7 Audio Setup Page (AUX and Music Enabled)

Table 3-5 Audio Setup Page Selections

Selection	Description
INTERCOM (ENABLED/DISABLED)	Turns the intercom function on or off. When intercom is disabled, music and auxiliary inputs are also disabled. Intercom Disabled is the suggested setting when the GTR is being wired to an audio panel. This setting may also affect Sidetone functionality, see Section 3-4 . Using a headset that has a MIC Telephone switch option may disable the intercom function. To restore intercom function, turn the MIC Telephone switch to the Off position, and power cycle the GTR 200/200B.
RECEIVER OUT GAIN	When the intercom is enabled, RECEIVER AUDIO OUT (pin 10) will output everything the pilot hears in the headset ear speakers with the exception of music audio. If RECEIVER AUDIO OUT is used as the source of audio to a recording device then adjust the RCVR OUT GAIN setting for desired audio level at the recording device.
AUX SQ 1 & 2	AUX SQ prevents low level noise from being passed to the headset ear speakers. Adjust the AUX SQ level so the audio background noise is muted. Warning, adjusting the AUX SQ to a high level may squelch the desired audio.
AUX VOL 1 & 2	If AUX1 or AUX2 inputs are used these settings allow adjusting the volume of the AUX inputs.
AUX MUTE (MUSIC) 1 & 2	This setting when enabled, will mute the music input if AUX1 or AUX2 input levels are sufficient to break AUX SQ.
PILOT ON RIGHT SIDE	Select YES or NO to select pilot location. When YES is selected the copilot is positioned to the left of the pilot for 3D audio processing.

3.6.4.4 Softkey Setup Page

The Softkey Setup page (Figure 3-8) allows the installer to configure the operation of Softkey 1 (top) and Softkey 2 (bottom), per the options listed in Table 3-6. Note that both softkeys cannot select the same function (except Disabled).

Refer to [Section 3.6.4](#) to select the Softkey Setup Page. Use the LARGE Knob to scroll through the listed functions, then use the SMALL Knob to adjust the setting of the function. After the setting has been changed, turn the LARGE Knob to move the cursor to another function.



Figure 3-8 Softkey Setup Page

Table 3-6 Softkey Setup Page Selections

Selection	Description
DISABLED	Disables softkey
PILOT PTT*	Radio transmits pilot MIC audio when key pressed
PILOT ISOLATION*	Isolates pilot from copilot and music
MUSIC ON/OFF*	Turns music input on/off
USER LIST	Moves directly to user frequency list menu
TUNE EMERGENCY	Sets active frequency to emergency frequency, 121.500
USR FREQ MEM CYCLE	Allows one of the softkeys to be used to cycle through stored user COM frequencies
MEDIA CONTROLS */**	Moves directly to media control menu
MEDIA PLAY/PAUSE */**	Toggles between media control play and pause
TELEPHONE */**	Moves directly to the telephone menu

*Indicates that function is not available when the intercom is set to off

**Indicates the function is only available on the GTR 200B model

3.6.4.5 Discrete Setup Page

The Discrete Setup page (Figure 3-9) allows the installer to configure the operation of the discrete inputs per the options listed in Table 3-7. It is not necessary to connect the discrete inputs, if a discrete input is used it is normally connected to a momentary contact pushbutton.

Refer to [Section 3.6.4](#) to select the Discrete Setup Page. Use the LARGE Knob to scroll through the listed functions, then use the SMALL Knob to adjust the setting of the function. After the setting has been changed, turn the LARGE Knob to move the cursor to another function. Note that both discrete inputs cannot select the same function (except Disabled). For testing purposes, an “X” will appear in the DISC 1 and/or the DISC 2 checkbox when the input(s) are active (see [Section 3.6.5.5](#)).



Figure 3-9 Discrete Setup Page

Table 3-7 Discrete Setup Page Selections

Selection	Description
DISABLED	Discrete input is disabled.
PILOT ICS KEY	Discrete input activates the pilot ICS function. Auto squelch and manual squelch are overridden when the PILOT ICS KEY is asserted.
COPILOT ICS KEY	Discrete input activates the copilot ICS function. Auto squelch and manual squelch are overridden by COPILOT ICS KEY selection.
FREQ SWAP BTN	Discrete input activates the frequency swap function (a beep tone is sounded). When held active for one second, the active frequency is tuned to the emergency frequency 121.500.
USR FREQ CYCLE BTN	Discrete input activates cycle through stored user COM frequencies.
STBY MONITOR BTN	Discrete input toggles Standby Monitor function.

3.6.4.6 Lighting Setup Page

The Lighting Setup page (Figure 3-10) allows the installer to configure the operation of the bezel keys and display lighting, per the options listed in Table 3-8.

Refer to [Section 3.6.4](#) to select the Lighting Setup Page. Use the LARGE Knob to scroll through the listed functions, then use the SMALL Knob to adjust the setting of the function. After the setting has been changed, turn the LARGE Knob to move the cursor to another function.

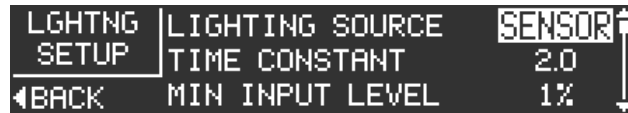

Figure 3-10 Lighting Setup Page

Table 3-8 Lighting Setup Page Selections

Selection	Description
LIGHTING SOURCE	SENSOR - Bezel keys and display lighting is controlled by the light sensor (photocell) on the front panel.
	14V - Configures the lighting bus source voltage to 14V. Bezel keys and display lighting is controlled by the input voltage (0-14 VDC) on pin 3.
	28V - Configures the lighting bus source voltage to 28V. Bezel keys and display lighting is controlled by the input voltage (0-28 VDC) on pin 3.
TIME CONSTANT	Adjusts the speed (in seconds), that the brightness level responds to changes in the input level.
MIN INPUT LEVEL	Sets the lower input level required to turn the backlighting on to the percentage of brightness set by the Min Brightness setting.
MIN BRIGHTNESS	Sets the minimum brightness of the display backlight.
MAX INPUT LEVEL	Sets the upper input level required to turn the backlighting on to the percentage of brightness set by the Max Brightness setting.
MAX BRIGHTNESS	Sets the maximum brightness of the display backlight.
OFF THRESHOLD	Sets the lighting bus off threshold level. At the threshold level, the backlighting is turned on per the Min Brightness setting. Below the threshold level, the backlighting defaults to a Backlight Level of 100%. If the value is set to 0%, the value will be ignored and the display brightness will remain at the Min Brightness level for any input level between 0% and the Min Brightness level. This setting is not available when Lighting Source is set to SENSOR.
OFF HYSTERESIS	Sets the range that the 100% Backlight Level is in effect after the input level rises above the Off Threshold. This setting is not available when Lighting Source is set to SENSOR.
BUTTON OFFSET	Adjusts the bezel backlight to be brighter than display backlight. Bezel lighting appears dimmer than display lighting when set to the same brightness level (default offset is 4%). Bezel backlight can be brightened by raising the BUTTON OFFSET value.
VIEW GRAPH	Press the SMALL Knob to display the Lighting Graph (Figure 3-11).

The Lighting Graph page Figure 3-11 graphically displays the input (voltage or percentage of lighting sensor) and brightness in real time. Brightness level is displayed as the vertical (Y) axis, and input level is displayed as the horizontal (X) axis. The graph changes according to the backlight control settings, and the lighting source input level.

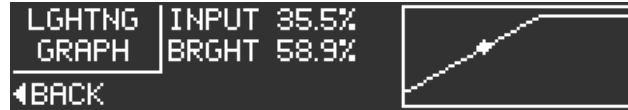

Figure 3-11 Lighting Graph

3.6.4.7 RS-232 Status Page

The RS-232 Status page (Figure 3-12) allows the installer to verify if RS-232 data is being received or transmitted. The indicators next to both 'RX' and 'TX' will blink if data is being transmitted or received. The RS-232 Status page is an information only page, there are no user-selectable settings.



Figure 3-12 RS-232 Status Page

3.6.5 Unit Ground Checks (Configuration Mode)

Refer to [Section 3.6.3](#) to put the GTR 200/200B into configuration mode.

3.6.5.1 Headset Tests Page

The Headset Tests page (Figure 3-13) allows the installer to test the operation of the headset outputs.

Refer to [Section 3.6.4](#) to select the Headset Tests Page.

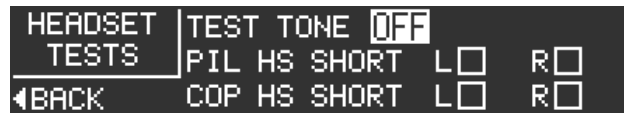

Figure 3-13 Headset Tests Page

Stereo headsets with the stereo setting selected must be used with 3D audio. Stereo headsets are shipped set to mono. Make sure the headsets used for this test are set to the stereo position.

A true mono headset will work correctly with the GTR 200/200B, but only mono audio will be heard and 3D audio will not be available. The GTR 200/200B will detect the mono headset and automatically switch to mono operation. Refer to [Appendix D-1](#) Note 4, MONO PLUG. A mono headset plug can be identified by the absence of the RING. Perform the below procedure to verify proper headset configuration.

1. Connect a stereo headset to the pilot headset position.
2. Move to the HEADSET TEST subpage.
3. Verify that none of the HS SHORT checkboxes are checked.
 - a) If the HS SHORT L checkbox is checked it is likely that there is an installation wiring problem.
 - b) If the HS SHORT R checkbox is checked it is likely that a mono headset is plugged in or there is an installation wiring problem.
 - c) If both the HS SHORT L and R checkboxes are checked it is likely that a stereo headset set to mono is plugged in.
 - d) If any of the HS SHORT checkboxes are checked, and no headset is plugged in, check for an installation wiring problem.
4. Use the SMALL Knob to move through the TEST TONE positions. The positions are:
 - a) PIL LEFT – A tone should be heard in the left ear speaker of the pilot headset.
 - b) PIL RIGHT – A tone should be heard in the right ear speaker of the pilot headset.
 - c) COP LEFT – A tone should be heard in the left ear speaker of the copilot headset.
 - d) COP RIGHT – A tone should be heard in the right ear speaker of the copilot headset.
5. Verify that the test tone is heard in the correct headset ear speaker and the tone is not heard in any other position.
6. Repeat the test for the copilot headset position.

3.6.5.2 COM Tests Page

The COM Tests page (Figure 3-14) allows the installer to test the operation of the COM functions. Refer to [Section 3.6.4](#) to select the COM Tests Page.



Figure 3-14 COM Tests Page

Perform the below procedure to verify proper COM configuration.

1. Connect a headset to the pilot headset jacks.
2. Select the COM TESTS subpage.
3. Verify none of the checkboxes are checked. The checkboxes are:
 - a) TX – Indicates the radio is transmitting.
 - b) RX – Indicates the radio is receiving.
 - c) SQ – Indicates the radio squelch is overridden. Radio squelch can be overridden by pushing the volume knob.
 - d) LO VOLT - Indicates the radio input voltage is low. The radio will reduce TX power or stop transmitting completely depending on the voltage level.
 - e) HI TEMP – Indicates the transmitter temperature is high. If transmitter temperature is high the radio will reduce TX power until the temperature lowers.
 - f) TX AMPS – This is not a checkbox. This indicates how much current (in Amps) is supplied to the transmitter. When the GTR 200/200B is transmitting the current draw will be approximately 3.0 Amps under ideal load conditions. When the GTR 200/200B is not transmitting the current draw will be around 0.01 Amps.
4. If the LO VOLT checkbox is checked this indicates a low battery condition or wiring fault that is preventing the radio from receiving proper voltage. Correct this condition before proceeding with this test.
5. Select a frequency that is transmitting. An ATIS, ASOS, or other continuously transmitting frequency is a good choice. Frequency tuning works differently in configuration mode. The SMALL Knob changes the highlighted frequency field and the LARGE Knob moves the highlighted field.
6. Verify the RX checkbox is checked and the received audio can be heard in the headset.
7. Select a frequency that is safe for transmission. The antenna and coaxial cable must be properly connected to the radio before attempting to transmit.
8. Key the transmitter and verify the TX checkbox is checked while transmitting. If the checkbox does not check there is a wiring fault. If the checkbox is always checked there is a wiring fault.
9. If the radio is tuned to a frequency that is appropriate for a radio check, one can be performed as part of this test.
10. If the copilot position is wired for transmission repeat the test for the copilot position.

3.6.5.3 Audio Tests Page

The Audio Tests page (Figure 3-15) and the following procedure will ensure that the audio level into the GTR 200/200B AUX/Music inputs (listed in Table 3-9) is set to the ideal level for best sound quality and noise rejection. It will also ensure the audio level heard in the pilot headset is at the desired level.

Refer to [Section 3.6.4](#) to select the Audio Tests Page.

The solid bar represents the average signal level and the vertical line represents the peak level. If the AUX levels are not set correctly, alerts connected to the AUX inputs may be partially or completely muted. The AUX SQUELCH (see [Section 3.6.4.3](#)) can be adjusted if the AUX input level cannot be set to the proper range. The AUX SQUELCH will not require adjustment from the 30% setting if the input level is set to the proper range.



Figure 3-15 Audio Tests Page

Table 3-9 Audio Tests Source Selections

Selection	Description
OFF	No audio source selected.
AUX 1 & 2	Auxiliary inputs 1 and 2. These inputs are not muted.
MUSIC LEFT AND RIGHT	Stereo music input. This input can be muted.

1. Turn on the audio source connected to the AUX/Music input(s).
2. Place the GTR 200/200B in CONFIG MODE.
3. Select the AUDIO TESTS subpage.
4. Use the LARGE and SMALL Knobs to select the audio source.
5. With the audio source active adjust the audio source output level so the average level is between the two marks on the level bar.
6. Use the LARGE Knob to move to the VOL selection.
7. While wearing a headset use the SMALL Knob to adjust the headset volume to the desired level.
8. Repeat for any other AUX/Music inputs.

3.6.5.4 Lighting Bus Interface Check

The display and bezel key backlighting on the GTR 200/200B can track an external lighting/dimmer bus input and use it to vary the display and bezel key backlight levels accordingly. This check is only applicable if Lighting Source (on the Lighting Setup Page, [Section 3.6.4.6](#)) is set to 14V or 28V, and verifies that the interface is connected correctly.

1. Refer to [Section 3.6.4](#) to select the Lighting Setup Page.
2. Ensure the lighting bus input is set to its minimum setting.
3. Slowly vary the input lighting bus level. Verify that the display brightness tracks the lighting bus setting. Continue to maximum brightness and verify proper operation.

3.6.5.5 Discrete Input Checkout

If one or both discrete inputs (Table 3-10) are connected, the wiring is checked using the following procedure.

1. Refer to [Section 3.6.4](#) to select the Discrete Setup Page ([Section 3.6.4.5](#)).
2. While the momentary contact pushbutton(s) are not being pressed (inputs are not grounded), verify the DISC 1 and DISC 2 check boxes are not checked. If one or both boxes is checked, the wiring is likely the cause of the failure.
3. Activate the DISC 1 and/or DISC 2 input by pressing the associated momentary contact pushbutton (inputs are grounded). Verify the appropriate checkbox is checked. If the checkbox is not checked the wiring is likely the cause of the failure.

Table 3-10 Discrete Inputs

Pin	Pin Name	Description
2	DISC 1	Configurable discrete active low input 1
22	DISC 2	Configurable discrete active low input 2

3.6.6 Unit Ground Checks (Normal Mode)

3.6.6.1 TX Interlock Checkout

Connect pins 4 and 5 per [Appendix D](#).

Table 3-11 TX Interlock Connections

Pin	Pin Name	Description
4	TX INTERLOCK OUT	Active low output that indicates the GTR 200/200B is transmitting. This output is normally connected to the TX INTERLOCK IN of other COM radios installed in the aircraft.
5	TX INTERLOCK IN	Active Low Input that 'desenses' (protects) the GTR 200/200B receiver when another communications radio is transmitting. This input comes from another communication radio's interlock output or MIC KEY line.

3.6.6.2 Antenna Check

If desired, the antenna VSWR can be checked using an inline wattmeter in the antenna coaxial using frequencies near both ends of the band. The VSWR should be less than 2:1. A VSWR of 2:1 will cause a drop in output power of approximately 12%.

3.6.6.3 Receiver/Transmitter Check

Tune the unit to a local VHF frequency and verify the receiver output produces a clear and understandable audio output. Verify the transmitter functions properly by contacting another station and getting a report of reliable communications.

3.6.6.4 RS-232 Serial Interface Checks

The interfaces to RS-232 equipment such as the G3X sources should be checked as follows:

1. Operate the connected serial remote tune source and the GTR 200/200B in normal mode.
2. Ensure that the remote source, if capable, is able to display data from the GTR 200/200B.
3. Ensure that the remote source, if capable, is able to tune the GTR 200/200B.

3.6.7 Flight Checks

3.6.7.1 COM Flight Check

After the installation is complete, perform the following required flight checks to ensure satisfactory transceiver performance.

Check the communications transceiver at a range of at least 50 nautical miles: (This check verifies unit receiver sensitivity test and transmitter range)

1. Maintain an altitude of 5000 ft AGL.
2. Select the frequency of a ground station facility at a range of at least 50 nautical miles.
3. Verify that communication (RX and TX) can be established with that facility.

Check the communications receiver by receiving transmission from a ground station in close proximity (range of less than 10 nautical miles): (This check verifies that the receiver has a high signal to noise ratio when receiving a strong signal.)

1. Select the frequency of a ground station facility at a range of less than 10 nautical miles.
2. Make sure the received audio from that station is clear (no background electrical noise).
3. If possible, perform the preceding steps 1 and 2 for frequencies in the high (~136.XXX MHz), mid (~127.XXX MHz), and low (~118.XXX MHz) range of the GTR 200/200B.

3.7 Unit Software

3.7.1 Checking Software Version

The GTR 200/200B comes pre-loaded with system software. However, if the software is out of date, it is recommended that current software be loaded from a micro SD card into the GTR 200/200B.

The current software version can be displayed in normal operation mode by pressing the MENU Key, then highlighting SETUP and pressing the SMALL Knob. The serial number, system software version, and boot block software version are displayed.



Figure 3-16 About Page

3.7.2 Software Update

The Software Update page (Figure 3-17) allows the installer to load unit software using a micro SD software loader card. [Section 3.7.3](#) lists instructions on creating the loader card



NOTE

Garmin recommends the use of a Sandisk® brand 4GB micro SD card for updating unit software.



Figure 3-17 Software Update Page

3.7.3 Creating a Software Loader Micro SD Card



NOTE

Note: The application to create a loader card requires Windows 2000, XP, Vista, Windows 7, or Windows 10. There is no Mac support at this time.

1. Go to the GTR 200/200B web page on Garmin’s web site.
2. Download the GTR 200/200B System software to your PC.
3. Ensure that you have a micro SD card (Garmin recommends a Sandisk® brand 4GB micro SD card) connected to the PC in the micro SD card slot or by using an SD card adapter that allows a micro SD card to be used.
4. Run the executable file that was downloaded and follow the prompts on the screen to create the software loader card.
5. After the card has been created, select finish to complete the process.
6. Remove the card from the slot. The loader card is now ready to use.

3.7.4 Loading Software to the GTR 200/200B

To load software to the GTR 200/200B, ensure that the unit is turned off.

1. Insert a micro SD card with pins facing up into the slot on the unit face as shown in Figure 3-18

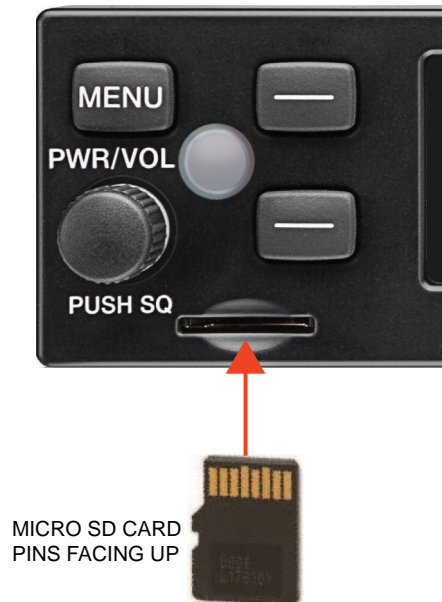

Figure 3-18 Micro SD Insertion

2. Power on the GTR 200/200B.
3. The GTR 200/200B will automatically check the micro SD card for updated software.



Figure 3-19 Software Update Page - Scanning Card

- a) If the software on the SD card matches the software in the GTR 200/200B the display will show “VER X.XX UP TO DATE PLEASE REMOVE CARD”. Note that this screen (Figure 3-20) will also be displayed following a successful software update and reboot.



Figure 3-20 Software Update Page - No Update Found

- b) The micro SD card can be removed or the cancel soft key can be pressed to return the GTR 200/200B to normal operation. If the cancel soft key is used, the same screen will be displayed at the next power cycle.
4. If the micro SD card contains updated software the GTR 200/200B will prompt to load the software.



Figure 3-21 Software Update Page - Update Software?

5. To load software select YES and press the SMALL Knob. The GTR 200/200B will prepare to update the software.



Figure 3-22 Software Update Page - Preparing Update

6. Once preparation is complete the GTR 200/200B will reboot. Reboot will happen automatically after a short time or reboot can be manually initiated by selecting OK and pressing the SMALL Knob.



Figure 3-23 Software Update Page - Unit Will Reboot

7. Do not remove power until the software update has completed. After the reboot the software update process is complete and the unit will display “No Update Found Please Remove Card”. the micro SD card may be removed at this time.



NOTE

If a Bluetooth firmware update is included with the software update, the Bluetooth firmware will be updated automatically after the GTR 200B reboots. While a Bluetooth firmware update is being performed in the GTR 200B, the status on the Bluetooth menu page in normal mode will report UPDATING FIRMWARE. When the Bluetooth update is completed, the Bluetooth functions will return to normal operation.

3.8 Disabling Bluetooth®

To aid in troubleshooting the GTR 200B, Bluetooth function can be disabled. To disable Bluetooth:

1. In normal mode, press the MENU button.
2. Scroll down and select BLUETOOTH (to enter the Bluetooth page).
3. Press and hold the SMALL Knob for 3 seconds.
4. The Bluetooth page should indicate BLUETOOTH DISABLED.

To re-enable Bluetooth without power cycling:

1. Press and hold the SMALL Knob for 3 seconds.
2. The Bluetooth page will indicate BLUETOOTH INITIALIZING and then return to normal operation.



NOTE

Once disabled, the GTR 200B Bluetooth function does not remain disabled after turning the unit off and back on. The GTR 200B Bluetooth function is always enabled following a power cycle.

3.9 Continued Airworthiness

Other than for regulatory checks, maintenance of the GTR 200/200B is 'on condition' only. Periodic maintenance of the GTR 200/200B is not required. Instructions for Continued Airworthiness (ICA) are not required for this product under 14 CFR Part 21 since the GTR 200/200B has received no FAA approval or endorsement.

4 CONNECTOR PINOUT INFORMATION

4.1 Pin Function List

4.1.1 J2001 Connector

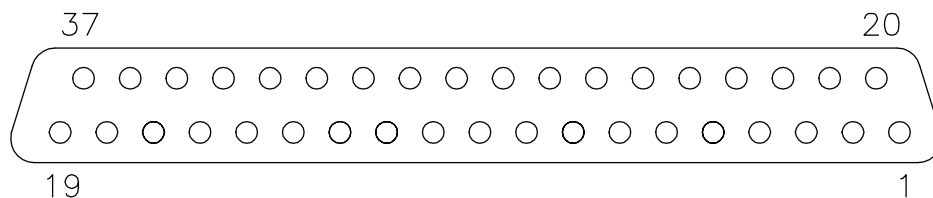

Figure 4-1 J2001 Looking at rear of unit

Table 4-1 J2001 Connector

Pin	Pin Name	I/O
1	AIRCRAFT POWER	In
2	DISC 1*	In
3	LIGHTING BUS IN	In
4	TX INTERLOCK OUT	Out
5	TX INTERLOCK IN*	In
6	CAN BUS LO	--
7	CAN BUS HI	--
8	ID IN	In
9	AUX MONO IN 2	In
10	RECEIVER AUDIO OUT HI	Out
11	COPILOT HS RIGHT	Out
12	COPILOT HS LEFT	Out
13	PILOT HS RIGHT	Out
14	PILOT HS LEFT	Out
15	COPILOT PTT*	In
16	COPILOT MIC IN	In
17	PILOT MIC IN	In
18	MUSIC IN RIGHT	In
19	MUSIC IN LEFT	In
20	AIRCRAFT GROUND	--
21	SPARE	--
22	DISC 2*	In
23	RS232 OUT	Out
24	RS232 IN	In
25	CAN TERM B	--
26	CAN TERM A	--
27	ID LO	--
28	AUX 2 LO	--

*Indicates Active Low

Table 4-1 J2001 Connector

Pin	Pin Name	I/O
29	RECEIVER AUDIO LO	--
30	COPILOT HS LO	--
31	AUX 1 LO	--
32	AUX MONO IN 1	In
33	PILOT HS LO	--
34	COPILOT MIC LO	--
35	PILOT PTT*	In
36	PILOT MIC LO	--
37	MUSIC LO	In

*Indicates Active Low

4.2 Power

Pins 1 & 20 supply power to the GTR 200/200B. Refer to drawings in [Appendix D](#) for power and ground wire gauges.

Pin Name	Pin	I/O
AIRCRAFT POWER	1	In
AIRCRAFT GROUND	20	--

4.3 Lighting Bus

The lighting bus is configurable for either 14 or 28 Vdc input ([Section 3.6.4.6](#)). This pin is an input that uses an external reference voltage to control the brightness of the display and backlight (it is not used to power the lighting). The input impedance is approximately 163 k Ω .



CAUTION

Connecting the lighting bus to an incorrect pin can cause damage to the unit that will require return to the factory for repair. Make sure that the lighting bus is connected to the correct pin and does not short to any adjacent pins prior to applying power to the unit.

Pin Name	Pin	I/O
LIGHTING BUS IN	3	In

4.4 CAN Bus

The CAN bus conforms to the BOSCH standard for Controller Area Network 2.0-B, and complies with ISO 11898. Pins 25 and 26 are used to terminate the CAN bus. The CAN bus on J2001 is used for communications between G3X system LRUs, and is the preferred connection method to G3X systems.

The GTR 200/200B should only be terminated if it is located at the end of the CAN bus. To terminate the CAN bus at the GTR 200/200B, short pins 25 and 26 together, this creates a 120 ohm termination internal to the GTR 200/200B LRU. If installed, the jumper between pins 25 and 26 should be 3" or less, and contained completely within the connector backshell.

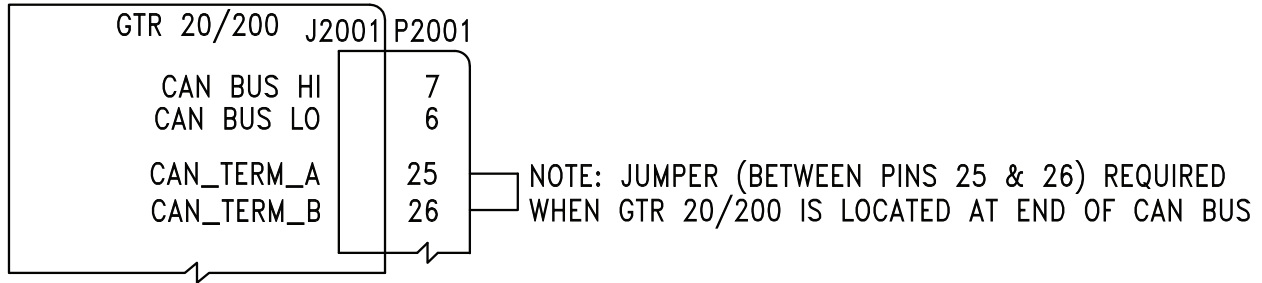

Figure 4-2 CAN Bus Termination for GTR 200/200B

Pin Name	Pin	I/O
CAN BUS LO	6	I/O
CAN BUS HI	7	I/O
CAN TERM B	25	--
CAN TERM A	26	--

4.5 Unit ID

The Unit ID pins are used for setting up the GTR 200/200B to be identified in the G3X system when connected by the CAN bus as either a COM 1 or a COM 2 radio.

For installations with dual GTR 200/200B radios, leave pin 8 open to identify the GTR 200/200B as COM 1. Connect pin 8 to pin 27 on the second GTR 200/200B to identify it as COM 2. If installed, the jumper between pins 8 and 27 should be 3" or less, and contained completely within the connector backshell.

For single installations do not connect pin 8 to pin 27 (leave open) to identify the GTR 200/200B as COM 1.

Refer to drawings in [Appendix D](#) for ID connections.

Pin Name	Pin	I/O
ID IN	8	In
ID LO	27	--

4.6 Serial Data – RS-232

Section 4.6.1.1 details the formats that can be selected for the RS-232 channel.



NOTE

The GTR 200/200B can be installed into the G3X system using an RS-232 or CAN bus (preferred) connection.

Pin Name	Pin	I/O
RS-232 IN	24	In
RS-232 OUT	23	Out

4.6.1 NMEA Format

4.6.1.1 Legacy NMEA Support

The GTR 200/200B maintains backwards compatibility with legacy SL30/SL40 NMEA commands (\$PMMRC and \$PMMRV) as they apply to GTR 200/200B functionality. Refer to [Appendix B](#).

The following legacy SL30/40 input commands are supported as-is:

- Set active COM frequency (SL30 version)
- Set active frequency and transceiver function (SL40 version)
- Set standby COM frequency. (SL30 version)
- Set standby frequency and transceiver function. (SL40 version)
- Squelch Override On/Off
- Remote Ident Input
- Remote Frequency List Input

4.7 MIC Audio

PILOT MIC IN and COPILOT MIC IN are standard carbon or dynamic MIC inputs with integrated preamps providing minimum 20 mVrms into a 150 Ω AC load.

PILOT MIC IN and COPILOT MIC IN are set in the factory so that 150 mVrms modulates the transmitter to 90% nominally at 1000 Hz. The microphone gain adjustment is made through Configuration Mode.

Pin Name	Pin	I/O
PILOT MIC IN	17	In
PILOT MIC LO	36	--
COPILOT MIC IN	16	In
COPILOT MIC LO	34	--

4.8 Aux Mono Audio

Auxiliary audio mono audio inputs have a nominal input impedance of 600 Ω , max. rated input level is 5 Vrms.

Pin Name	Pin	I/O
AUX MONO IN 1	32	In
AUX 1 LO	31	--
AUX MONO IN 2	9	In
AUX 2 LO	28	--

4.9 Headset Audio

Headset audio outputs

Pin Name	Pin	I/O
PILOT HS RIGHT	13	Out
PILOT HS LEFT	14	Out
PILOT HS LO	33	--
COPILOT HS RIGHT	11	Out
COPILOT HS LEFT	12	Out
COPILOT HS LO	30	--

4.10 Music Inputs

The music inputs are noise rejecting and have a nominal input impedance of 600 Ω . The max. rated input level is 1.5 Vrms. The MUSIC LO must be connected to the music source along with MUSIC RIGHT and MUSIC LEFT. If MUSIC LO is not connected, music volume will be low (or inaudible), noisy, and distorted.

Pin Name	Pin	I/O
MUSIC IN RIGHT	18	In
MUSIC IN LEFT	19	In
MUSIC LO	37	--

4.11 Receiver Audio

RECEIVER AUDIO OUT is a 40 mW audio output that is intended to drive a recording device or an audio panel.

RECEIVER AUDIO OUT supplies 40 mW (4.9 Vrms) into a 600Ω load, and is generally connected to the audio panel (if used). This output can also drive a recording device. When driving a recording device the output level will typically need to be reduced. The output level is controlled through configuration mode.

RECEIVER AUDIO OUT is the summation of the receiver audio, COM sidetone audio, intercom audio, and AUX audio.

Pin Name	Pin	I/O
RECEIVER AUDIO OUT HI	10	Out
RECEIVER AUDIO LO	29	--

4.12 Pilot/Copilot PTT Inputs

When pulled low, these inputs allow the audio that is present on the PILOT/COPILOT MIC IN to be transmitted over the radio.

Active-Low discrete inputs are considered active if either the voltage to ground is ≤ 3.5 VDC or the resistance to ground is ≤ 375 Ω.

These inputs are considered inactive if the voltage to ground is 6.5-33 VDC or the resistance to ground is >100 kΩ.

Pin Name	Pin	I/O
PILOT PTT*	35	In
COPILOT PTT*	15	In

*Indicates Active Low

4.13 TX Interlock

TX Interlock Out is an active low output that indicates that this radio's (GTR 200/200B) COM is transmitting. Connect to another COM's TX Interlock input. TX INTERLOCK OUT will sink 20mA of current and will output a voltage of 1V or less.

TX Interlock In is an active low input that desenses (protects) the COM receiver when another COM is transmitting.

TX Interlock In is considered active if either the voltage to ground is ≤ 3.5 VDC or the resistance to ground is ≤ 375 Ω.

TX Interlock In is considered inactive if the voltage to ground is 6.5-33 VDC or the resistance to ground is >100 kΩ.

Pin Name	Pin	I/O
TX INTERLOCK OUT	4	Out
TX INTERLOCK IN*	5	In

*Indicates Active Low

4.14 Discrete Inputs

These discrete inputs are active low and are configurable.

Active-Low discrete inputs are considered active if either the voltage to ground is ≤ 3.5 VDC or the resistance to ground is $\leq 375 \Omega$.

These inputs are considered inactive if the voltage to ground is 6.5-33 VDC or the resistance to ground is >100 k Ω .

Pin Name	Pin	I/O
DISC 1*	2	In
DISC 2*	22	In

*Indicates Active Low

APPENDIX A SHIELD BLOCK CONNECTOR INSTALLATION INSTRUCTIONS

A.1 Shield Block Installation Parts

[Table 2-3](#) and Table A-1 list the parts needed to install a Shield Block. Parts listed in [Table 2-3](#) are supplied in the GTR 200/200B Connector Kit (011-003240-00) and the GTR 200/200B Connector Kit FAA-PMA (011-003240-01). Parts listed in Table A-1 are to be provided by the installer.

Table A-1 Parts not supplied for a Shield Block Installation ([Figure A-1](#))

Figure Ref	Description	GPN or MIL spec
4	Multiple Conductor Shielded Cable (2-conductor shown in Figure A-1)	Parts used depend on method chosen
5	Drain Wire Shield Termination (method optional)	Parts used depend on method chosen
6	Braid, Flat (19-20 AWG equivalent, tinned plated copper strands 36 AWG, Circular Mil Area 1000 -1300)	Parts used depend on method chosen
7	Floating Shield Termination (method optional)	Parts used depend on method chosen
13	Silicon Fusion Tape	-



NOTE

In Figure A-1, "AR" denotes quantity "As Required" for the particular installation.

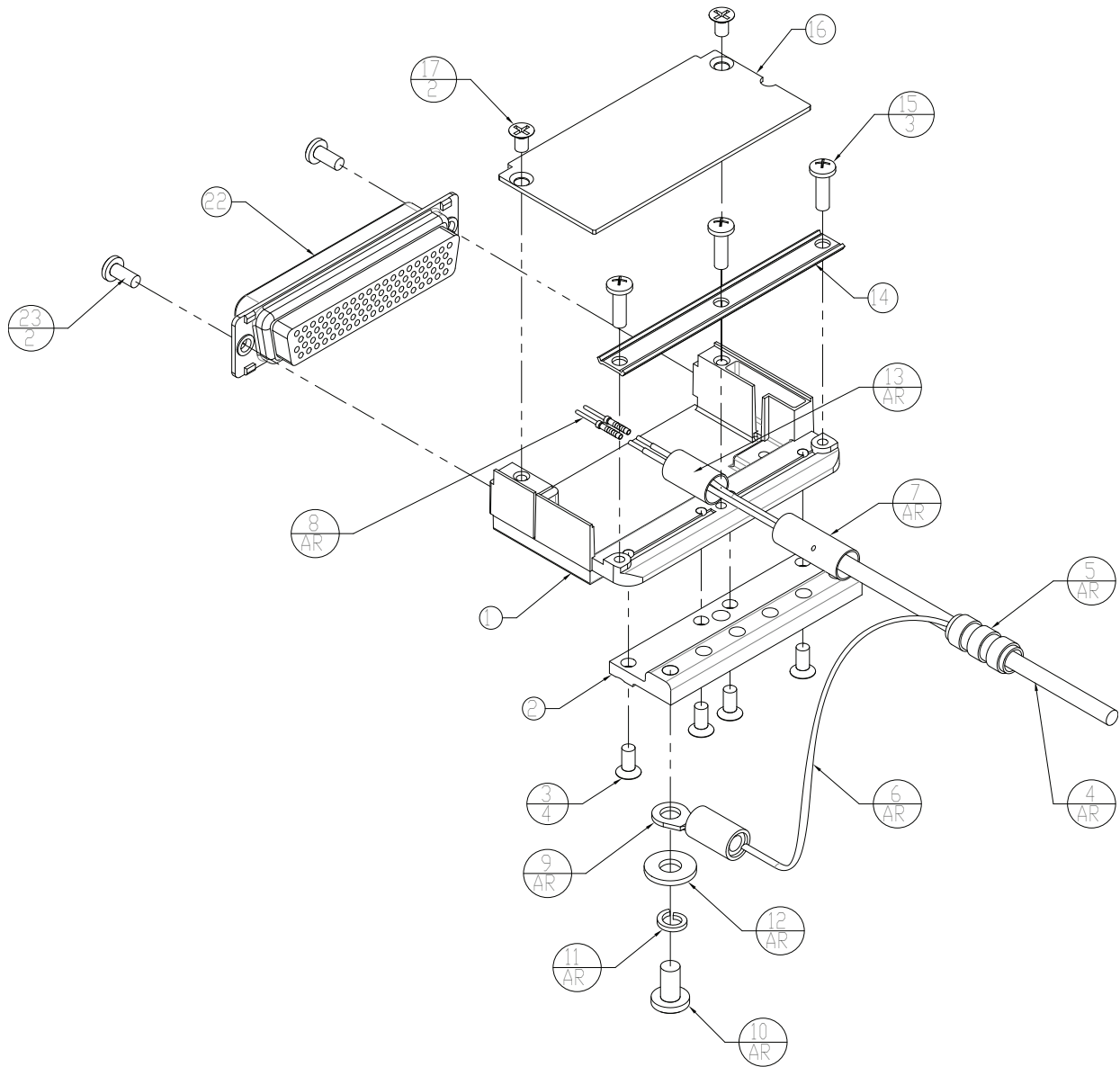

Figure A-1 Shield Block Install onto a Backshell

A.2 Shield Termination Technique – Method A.1 (Standard)

1. The appropriate number of Shield Block Backshells will be included in the particular LRU connector kit.

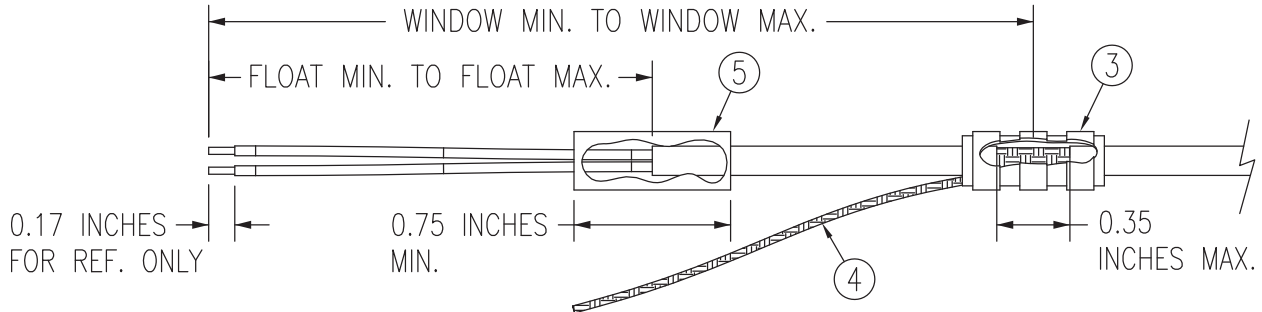

Figure A-2 Method A.1 for Shield Termination

Table A-2 Shielded Cable Preparations for Garmin Connectors

Backshell Size	Number of Pins Std/ HD	Float Min (inches)	Float Max (inches)	Ideal Float (inches)	Window Min (inches)	Window Max (inches)	Ideal Window (inches)
1	9/15	1.25	2.25	1.75	2.75	5.25	4.25
2	15/26	1.5	2.5	2.0	3.0	5.5	4.5
3	25/44	1.5	2.5	2.0	3.0	5.5	4.5
4	37/62	1.5	2.5	2.0	3.0	5.5	4.5
5	50/78	1.5	2.5	2.0	3.0	5.5	4.5

2. At one end of a shielded cable (item 4, [Figure A-1](#)) measure a distance between “Window Min” to “Window Max” (Table A-2) and cut a window (max size 0.35”) in the jacket to expose the shield (item 3, Figure A-2). Use caution when cutting the jacket to avoid damaging the individual braids of the shield. When dealing with a densely populated connector with many cables, it may prove beneficial to stagger the windows throughout the “Window Min” to “Window Max” range. If staggering is not needed the “Ideal Window” length is recommended.

Suggested tools to accomplish the window cut:

- Coaxial Cable Stripper
- Thermal Stripper
- Sharp Razor Blade

3. Connect a Flat Braid (item 4, [Figure A-2](#)) to the shield exposed through the window of the prepared cable assembly from step 2. The Flat Braid should go out the front of the termination towards the connector. It is not permitted to exit the rear of the termination and loop back towards the connector (see [Figure A-2](#)). Make this connection using an approved shield termination technique.



NOTE

FAA AC 43.13-1B Chapter 11, Section 8 (Wiring Installation Inspection Requirements) may be a helpful reference for termination techniques.

Preferred Method:

Slide a solder sleeve (item 3, [Figure A-2](#)) onto the prepared cable assembly and connect the Flat Braid (item 4, [Figure A-2](#)) to the shield using a heat gun approved for use with solder sleeves. It may prove beneficial to use a solder sleeve with a pre-installed Flat Braid versus having to cut a length of Flat Braid to be used. The chosen size of solder sleeve must accommodate both the number of conductors present in the cable and the Flat Braid (item 4, [Figure A-2](#)) to be attached.

Solder Sleeves with pre-installed Flat Braid

A preferred solder sleeve would be the Raychem S03 Series with the thermochromic temperature indicator (S03-02-R-9035-100, S03-03-R-9035-100, S03-04-R-9035-100). These solder sleeves come with a pre-installed braid and effectively take the place of items 3 and 4 shown in [Figure A-2](#). For detailed instructions on product use, reference Raychem installation procedure RCPS 100-70.

Raychem recommended heating tools:

- HL1802E
- AA-400 Super Heater
- CV-1981
- MiniRay
- IR-1759

Individual solder sleeves and Flat Braid

Solder Sleeves:

Reference the following MIL-Specs for solder sleeves.

(M83519/1-1, M83519/1-2, M83519/1-3, M83519/1-4, M83519/1-5)

Flat Braid:

If the preferred Raychem sleeves are not being used, the individual flat braid selected should conform to ASTM B33 for tinned copper and be made up of 36 AWG strands to form an approximately 19-20 AWG equivalent flat braid. A circular mil area range of 1000 to 1300 is required. The number of individual strands in each braid bundle is not specified. (e.g. QQB575F36T062)



NOTE

Flat Braid as opposed to insulated wire is specified in order to allow continuing air worthiness by allowing for visual inspection of the conductor.

Secondary Method:

Solder a Flat Braid (item 4, [Figure A-2](#)) to the shield exposed through the window of the prepared cable assembly. Ensure a solid electrical connection through the use of acceptable soldering practices. Use care to avoid applying excessive heat that burns through the insulation of the center conductors and shorts the shield to the signal wire. Slide a minimum 0.75 inches of Teflon heat shrinkable tubing (item 3, [Figure A-2](#)) onto the prepared wire assembly and shrink using a heat gun. The chosen size of heat shrinkage tubing must accommodate both the number of conductors present in the cable and the Flat Braid (item 4, [Figure A-2](#)) to be attached.

Teflon Heat Shrinkable Tubing:

Reference the following MIL-Spec for Teflon heat shrinkable tubing (M23053/5-X-Y).

4. At the same end of the shielded cable and ahead of the previous shield termination, strip back “Float Min” to “Float Max” ([Table A-2](#)) length of jacket and shield to expose the insulated center conductors ([Figure A-2](#)). The “Ideal Float” length may be best to build optimally.

Preferred Method:

The jacket and shield should be cut off at the same point so no shield is exposed. Slide 0.75 inches minimum of Teflon heat shrinkable tubing (item 5, [Figure A-2](#)) onto the cable and use a heat gun to shrink the tubing. The chosen size of heat shrinkage tubing must accommodate the number of conductors present in the cable.

Secondary Method:

Leave a max 0.35 inches of shield extending past the jacket. Fold this 0.35 inches of shield back over the jacket. Slide a solder sleeve (item 5, [Figure A-2](#)) over the end of the cable and use a heat gun approved for solder sleeves to secure the connection. The chosen size of solder sleeve must accommodate the number of conductors present in the cable.

5. Strip back approximately 0.17 inches of insulation from each wire of the shielded cable (item 2, [Figure A-3](#)) and crimp a contact (item 6, [Figure A-3](#)) to each conductor. It is the responsibility of the installer to determine the proper length of insulation to be removed. Wire must be visible in the inspection hole after crimping and the insulation must be 1/64 – 1/32 inches from the end of the contact as shown in [Figure A-3](#).

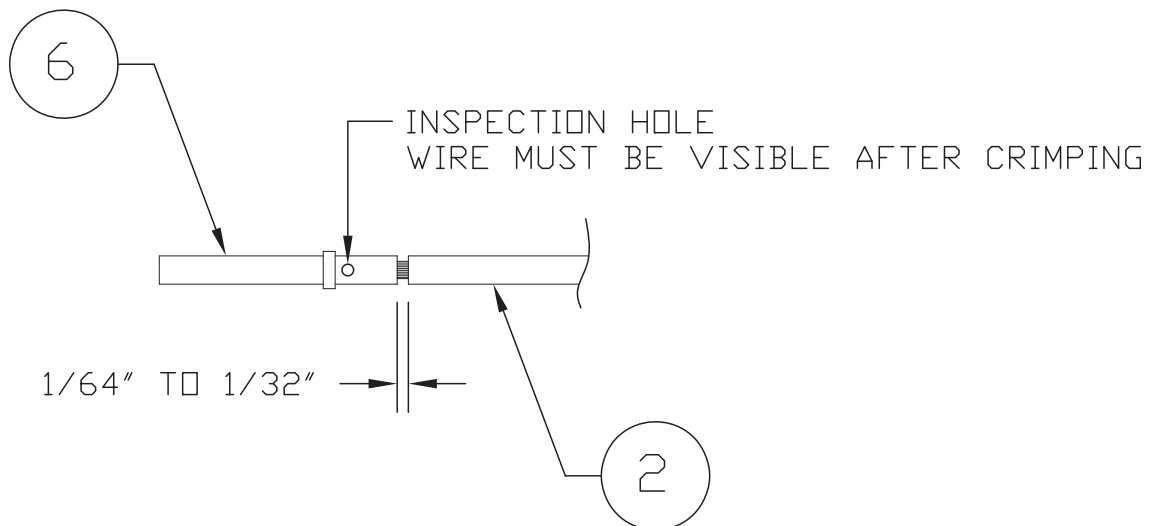

Figure A-3 Insulation/Contact Clearance

**NOTE**

Refer to [Figure A-1](#) for all item numbers in the following steps 6-13.

6. Insert newly crimped pins and wires into the appropriate connector housing location as specified by the installation wiring diagrams.
7. Cut the Flat Braid (item 6) to a length that, with the addition of a ring terminal, will reach one of the tapped holes of the Shield Block backshell (item 1). An appropriate amount of excess length without looping should be given to the Flat Braid (item 6) to allow it to freely move with the wire bundle.

**NOTE**

Position the window splice to accommodate a Flat Braid (item 6) length of no more than 4 inches.

8. Guidelines for terminating the newly cutoff Flat Braid(s) (item 6) with insulated ring terminals (item 9):
 - Each tapped hole on the Ring Terminal Adapter (item 2) may accommodate only two ring terminals (item 9).
 - It is preferred that only two Flat Braid(s) (item 6) be terminated per ring terminal. Two Flat Braids per ring terminal will necessitate the use of a Ring terminal, #8, insulated, 14-16 AWG (MS25036-153).
 - If only a single Flat Braid is left or if only a single Flat Braid is needed for this connector a Ring terminal, #8, insulated, 18-22 AWG (MS25036-149) can accommodate this single Flat Braid.
 - If more braids exist for this connector than two per ring terminal, it is permissible to terminate three braids per ring terminal. This will necessitate the use of a Ring terminal, #8, insulated, 10-12 AWG (MS25036-156).
9. Repeat steps 2 through 8 as needed for the remaining shielded cables.
10. Terminate the ring terminals to the Ring Terminal Adapter (item 2) by placing items on the Pan Head Screw (item 10) in the following order: Split Washer (item 11), Flat Washer (item 12) first Ring Terminal, second Ring Terminal (if needed) before finally inserting the screw into the tapped holes on the Ring Terminal Adapter. Do not violate the guidelines presented in Step 8 regarding ring terminals.
11. It is recommended to wrap the cable bundle with Silicone Fusion Tape (item 13) (GPN: 249-00114-00 or a similar version) at the point where the backshell clamp and cast housing will contact the cable bundle.

**NOTE**

Choosing to use this tape is the discretion of the installer.

12. Place the smooth side of the backshell clamp (item 14) across the cable bundle and secure using the three screws (item 15). Warning: Placing the grooved side of the clamp across the cable bundle may risk damage to wires.
13. Attach the cover (item 16) to the backshell (item 1) using the two screws (item 17).

A.3 Shield Termination Technique - Method A.2 (Daisy Chain)

In rare situations where more braids need to be terminated for a connector than three per ring terminal it is allowable to daisy chain a maximum of two shields together (see Figure A-4) before coming to the ring terminal. All other restrictions and instructions for the shield termination technique set forth for [Method A.1](#) are still applicable.



NOTE

The maximum length of the combined braids should be approximately 4 inches.

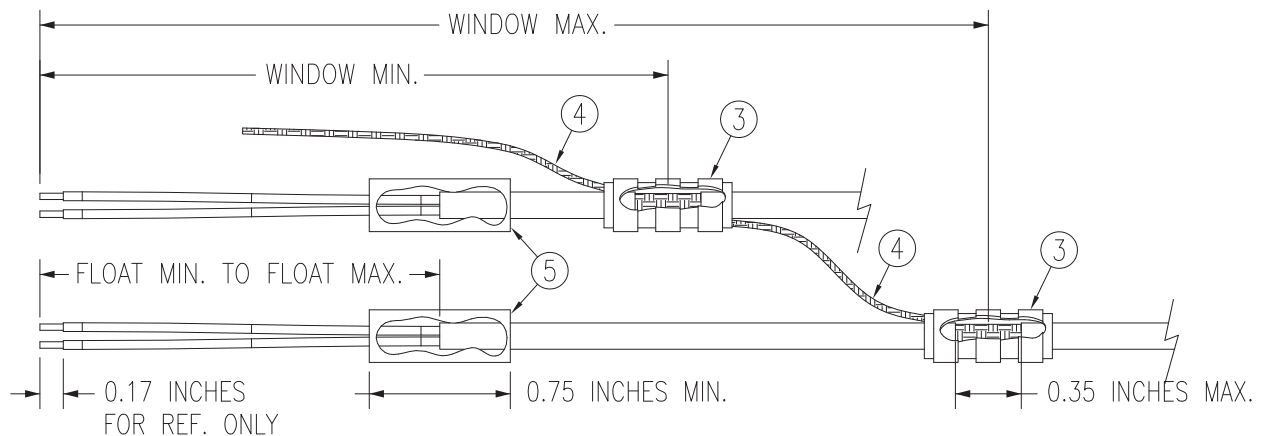

Figure A-4 Method A.2 (Daisy Chain) for Shield Termination

A.4 Shield Termination – Method B.1 (Quick Term)

If desired, the drain wire termination (item 3, Figure A-4) and the floating shield termination (item 5, Figure A-4) can be effectively combined into a “Quick Term”. This method eliminates the float in the cable insulation and moves the placement of the window which was described by the dimensions “Window Min” and “Window Max” from [Method A.1](#). This technique is depicted in [Figure A-5](#).



NOTE

The original purpose for separating the shield drain termination (item 3, Figure A-4) from the float termination (item 5, Figure A-4) in [Method A.1](#) was to allow for a variety of lengths for the drain wires so that the shield drain terminations (item 3, Figure A-4) would not all “bunch up” in the harness and to eliminate loops in the drain wires. If [Method B.1](#) is chosen, as described in this section, care must be taken to ensure that all drain shield terminations can still be inspected. With connectors which require a large number of shield terminations it may be best to use [Method A.1](#). This will allow the drain shield terminations (item 3, Figure A-4) a larger area to be dispersed across.

Using this method, the instructions from [Section A.2](#) (Method A) are followed except that:

1. Step 2 is eliminated
2. Steps 3 and 4 are replaced by the following:
At the end of the shielded cable (item 4, [Figure A-1](#)), strip “Quick Term Min” to “Quick Term Max” (Table A-3) length of the jacket to expose the shield. Next trim the shield so that at most 0.35 inches remains extending beyond the insulating jacket. Fold this remaining shield back over the jacket.

Connect a Flat Braid (item 4, Figure A-5) to the folded back shield of the prepared cable assembly. The flat braid should go out the front of the termination towards the connector. It is not permitted to exit the rear of the termination and loop back towards the connector (Figure A-5). Make this connection using an approved shield termination technique.



NOTE

FAA AC 43.13-1B Chapter 11, Section 8 (Wiring Installation Inspection Requirements) may be a helpful reference for termination techniques.

Preferred Method:

Slide a solder sleeve (item 3, Figure A-5) onto the prepared cable assembly and connect the Flat Braid (item 4, Figure A-5) to the shield using a heat gun approved for use with solder sleeves. It may prove beneficial to use a solder sleeve with a pre-installed Flat Braid versus having to cut a length of Flat Braid to be used. The chosen size of solder sleeve must accommodate both the number of conductors present in the cable and the Flat Braid (item 4, Figure A-5) to be attached.



NOTE

Reference [Section A.2](#) for recommended solder sleeves and flat braid. The same recommendations are applicable to this technique.

Secondary Method:

Solder a Flat Braid (item 4, Figure A-5) to the folded back shield on the prepared cable assembly. Ensure a solid electrical connection through the use of acceptable soldering practices. Use care to avoid applying excessive heat that burns through the insulation of the center conductors and shorts the shield to the signal wire. Slide a minimum of 0.75 inches of Teflon heat shrinkable tubing onto the prepared wire assembly and shrink using a heat gun. The chosen size of heat shrinkage tubing must accommodate both the number of conductors present in the cable as well as the Flat Braid (item 4, Figure A-5) to be attached.

Teflon Heat Shrinkable Tubing:

Reference the following MIL-Spec for general Teflon heat shrinkable tubing (M23053/5-X-Y)

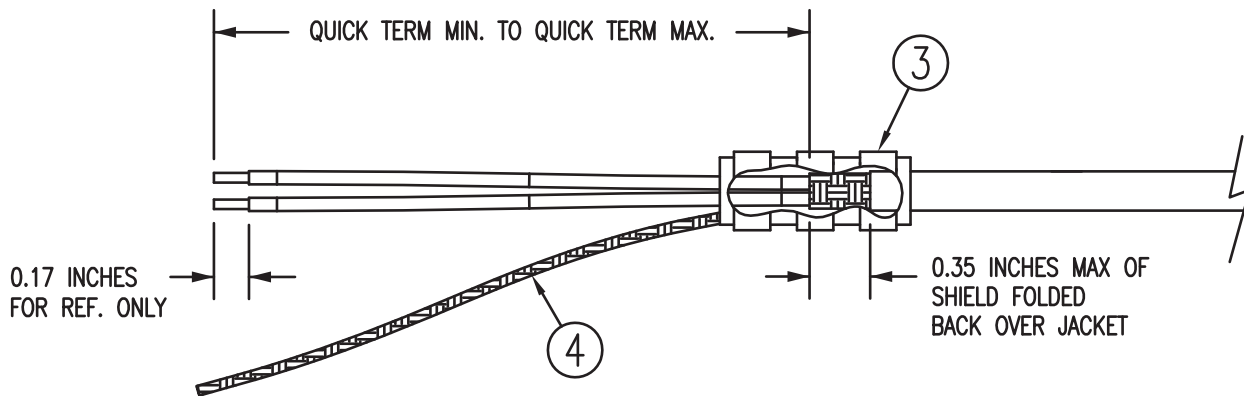

Figure A-5 Method B.1 (Quick Term) for Shield Termination

Table A-3 Shielded Cable Preparations – (Quick Term)

Backshell Size	Number of Pins Std/HD	Quick Term Min (inches)	Quick Term Max (inches)	Quick Term Float (inches)
1	9/15	1.25	2.25	1.75
2	15/26	1.5	2.5	2.0
3	25/44	1.5	2.5	2.0
4	37/62	1.5	2.5	2.0
5	50/78	1.5	2.5	2.0

A.5 Shield Termination-Method B.2 (Daisy Chain-Quick Term)

In rare situations where more braids need to be terminated for a connector than three per ring terminal it is allowable to daisy chain a maximum of two shields together before coming to the ring terminal (Figure A-6). All other restrictions and instructions for the shield termination technique set forth for [Method B.1](#) are still applicable.



NOTE

The maximum length of the combined braids should be approximately 4 inches.

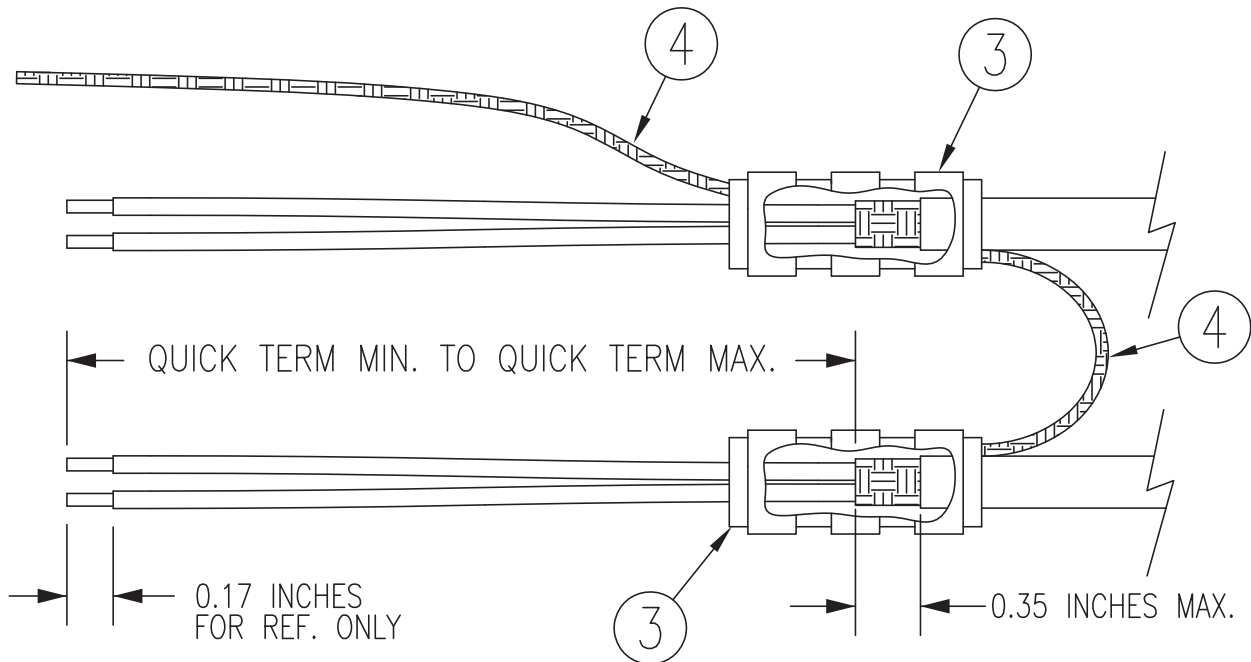

Figure A-6 Method B.2 (Daisy Chain-Quick Term) for Shield Termination

A.6 Daisy Chain between Methods A and B

In rare situations where more braids need to be terminated for a connector than three per ring terminal and a mixture of [Method A.1](#) and [Method B.1](#) have been used, it is allowable to daisy chain a maximum of two shields together from a Method A termination to a Method B (Figure A-7). All other restrictions and instructions for the shield termination technique set forth for Method A and B are still applicable.



NOTE

The maximum length of the combined braids should be approximately 4 inches.

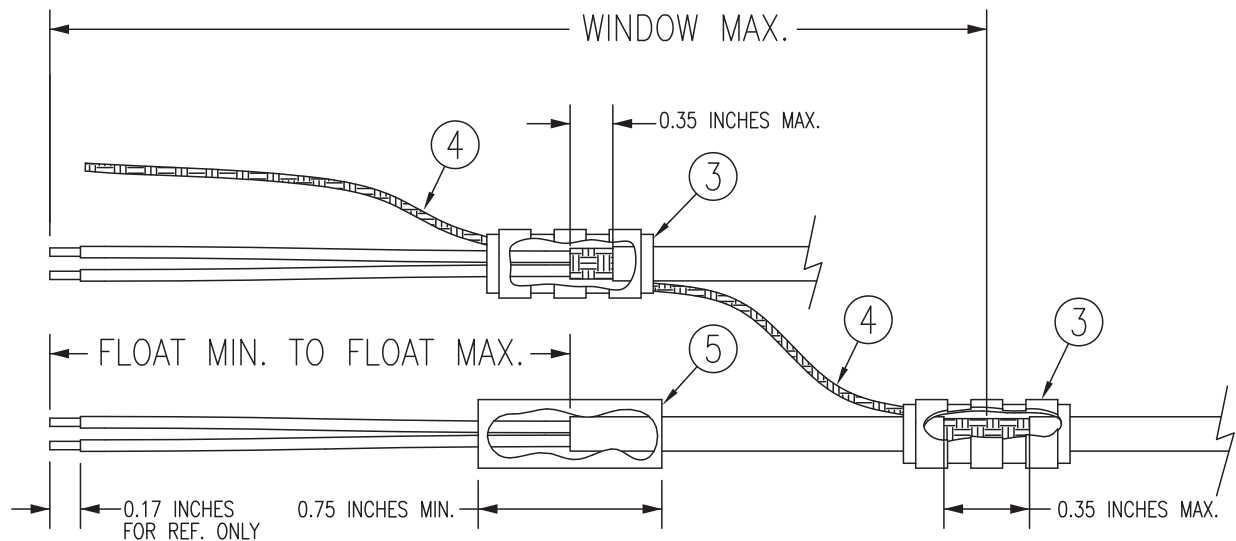

Figure A-7 Daisy Chain between Methods A and B

A.7 Splicing Signal Wires



NOTE

Figure A-8 illustrates that a splice must be made within a 3 inch window from outside the edge of clamp to the end of the 3 inch max mark.



WARNING

Keep the splice out of the backshell for pin extraction, and outside of the strain relief to avoid preloading.

[Figure A-8](#) shows a two wire splice, but a maximum of three wires can be spliced. If a third wire is spliced, it is located out front of splice along with signal wire going to pin.

Splice part numbers:

- Raychem D-436-36/37/38
- MIL Spec MIL-S-81824/1

This technique may be used with shield termination methods: [Method A.1](#), [Method A.2](#), [Method B.1](#), and [Method B.2](#).

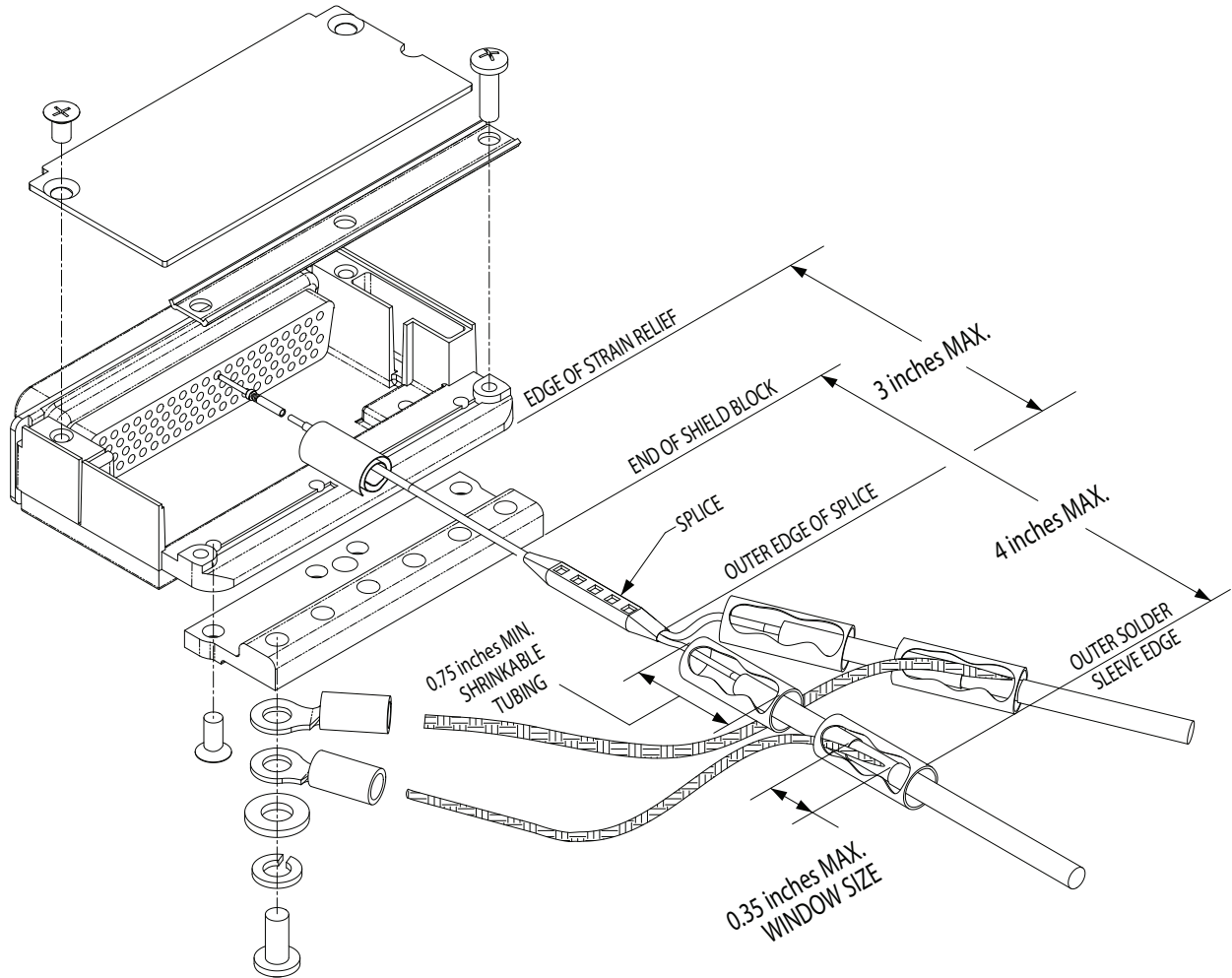

Figure A-8 D-Sub Spliced Signal Wire illustration

APPENDIX B SERIAL INTERFACE SPECIFICATIONS

B.1 Electrical Interface

The I/O signals are compatible with RS-232. Data is generated at 9600 baud with a word length of 8 bits, one stop bit, and no parity.

The data format for the serial communication is:

Baud rate	9600
Data bits	8
Stop bits	1
Parity	None

B.2 Message Formats

All messages conform to the NMEA 0183 proprietary message format as follows. All characters will be standard ASCII characters. No binary data characters are used.

- “\$” Start of message character, ASCII “\$” (024h).
- “P” Proprietary message identifier.
- iii Company identifier.
- c Message class identifier; Identifies a message as either a COMM or NAV message.
- nn Message identifier, two-digit number in ASCII characters.
- d.....d Message data characters defined for each message.
- Chksum Message checksum, including message identifier (nn) through data characters (d.....d). The two-digit checksum is generated by adding all values of valid characters together, ignoring carry (if any). This value is converted into two encoded hex¹ characters (30h-3Fh).
- <CR> ASCII carriage return (0Dh).
- <LF> ASCII line feed (0Ah).

¹Encoded hex: each character consists of 4 bits of data placed in the low order nibble +30h. For example, the 8-bit value 5Fh would be encoded as two characters with values of 35h and 3Fh, which map to the ASCII characters “5” and “?”, respectively.

The maximum message length, including the start of message character (“\$”) and the end of message <CR><LF> sequence, is 29 bytes.

B.2.1 Message Definitions

B.2.1.1 Frequency Types

B.2.1.1.1 Enhanced Frequency Type Enumeration

0	Tower
1	Ground
2	Automatic Terminal Information Service or ATIS
3	Air Traffic Frequency
4	Approach
5	Arrival
6	Automatic Weather Observing Station
7	Clearance/Delivery
8	Common Traffic Advisory Frequency
9	Departure
:	Flight Service Station
;	Remote Flight Service Station
<	Unicom
=	Mandatory Frequency
>	No type specified
?	Undefined
@	Center
A	Automated Surface Observing Station
B	Class B
C	Class C
D	Radio
E	Enroute
F	Enroute Flight Advisory Service or Flight Watch
G	Gate
H	Helicopter
I	Information
J	Weather
K	Terminal
L	Pilot controlled lighting
M	Multicom
N	Radar
O	Operations
P	Ramp
Q	Reserved - Undefined

B.2.1.1.2 Legacy Frequency Type Enumeration

0	Tower
1	Ground
2	Automatic Terminal Information Service or ATIS
3	Air Traffic Frequency
4	Approach
5	Arrival
6	Automatic Weather Observing Station
7	Clearance/Delivery
8	Common Traffic Advisory Frequency
9	Departure
:	Flight Service Station
;	Remote Flight Service Station
<	Unicom
=	Mandatory Frequency
>	No type specified
?	Undefined

B.2.2 Input Messages

B.2.2.1 Set Active Frequency and Transceiver Function

This message is used to set the Active frequency as well as the transceiver function.

Message format (GTR 200/200B):

“GRM”..... Company identifier.
 “C”..... Message class.
 “15”..... Message identifier.
 mk Active frequency: m = MHz, where m = desired MHz frequency - 30h, ranging from 118 to 136 MHz, (i.e. 76h to 88h, A2h); k = (KHz offset / 25KHz) + 30h, ranging from 000 to 975KHz in 25 KHz steps.
 a Transceiver function: N = normal, M = monitor, 0 = unchanged.
 “0”..... 8.33 KHz offset: (ASCII) 0 = 25 KHz frequency (.000)
 iiii..... Identifier string. Note that if the identifier string is less than four characters, left justify the string and insert spaces for empty characters. An empty identifier string (four spaces) is allowed. Identifiers are restricted to using ASCII characters 0-9 and A-Z.
 f..... Frequency type (see Extended Frequency Type Enumeration).

Example message:

```
$PGRMC15W=N0KIXDA<chksm><CR><LF>
```

This example command would set the active COM frequency to 135.325 MHz with an identifier of “KIXD ASOS”, and place the radio in Normal receive mode. This is interpreted by noting that the ASCII ‘W’ corresponds with 57h, +30h = 87h, converted to decimal equals 135 for the MHz portion. The KHz portion converts ASCII ‘=’ to 3Dh, -30h yields Dh, x25KHz steps = 325 KHz, with no 8.33 KHz channel offsets. The identifier string portion is “KIXD” and the frequency type ‘A’ corresponds to “Automated Surface Observing Station” in the extended frequency type enumeration.

Message format (GTR 225/GNC 255):

- “GRM”..... Company identifier.
- “C” Message class.
- “00” Message identifier.
- mk Active frequency: m = MHz, where m = desired MHz frequency - 30h, ranging from 118 to 136 MHz, (i.e. 76h to 88h, A2h); k = (KHz offset / 25KHz) + 30h, ranging from 000 to 975KHz in 25 KHz steps.
- a Transceiver function: N = normal, M = monitor, 0 = unchanged.
- “0” 8.33 KHz offset: (ASCII) 0 = 25 KHz frequency (.000)

Example message:

\$PGRMC00G4N0<chksm><CR><LF>

This example command would set the active COM frequency to 119.100 MHz and place the radio in Normal receive mode. This is interpreted by noting that the ASCII ‘G’ corresponds with 47h, +30h = 77h, converted to decimal equals 119 for the MHz portion. The KHz portion converts ASCII ‘4’ to 34h, -30h yields 4h, x25KHz steps = 100 KHz, with no 8.33 KHz channel offset.

Message format (SL 30):

- “MRR”..... Company identifier.
- “V” Message class.
- “42” Message identifier.
- mk Active frequency: m = MHz, where m = desired MHz frequency - 30h, ranging from 118 to 136 MHz, (i.e. 76h to 88h, A2h); k = (KHz offset / 25KHz) + 30h, ranging from 000 to 975KHz in 25 KHz steps.
- a Transceiver function: N = normal, M = monitor, 0 = unchanged.

Example message:

\$PMRRV42G4N<chksm><CR><LF>

Sets the active frequency to 119.100MHz, normal receive mode. “G” = 119d - 30h = 77h - 30h = 47h, or an ASCII “G”; “4” = 100 kHz/25 kHz + 30h = 4 + 30h = 34h, or an ASCII “4.”

Message format (SL 40):

- “GRM”..... Company identifier.
- “C” Message class.
- “00” Message identifier.
- mk Active frequency: m = MHz, where m = desired MHz frequency - 30h, ranging from 118 to 136 MHz, (i.e. 76h to 88h, A2h); k = (KHz offset / 25KHz) + 30h, ranging from 000 to 975KHz in 25 KHz steps.
- a Transceiver function: N = normal, M = monitor, 0 = unchanged.

Example message:

\$PMRRC00G4N<chksm><CR><LF>

Sets the active frequency to 119.100MHz, normal receive mode. “G” = 119d - 30h = 77h - 30h = 47h, or an ASCII “G”; “4” = 100 kHz/25 kHz + 30h = 4 + 30h = 34h, or an ASCII “4.”



NOTE

Input frequencies will be checked for validity. An RS-232 serial error message output will be generated if the frequency is invalid, or an 8.33 KHz frequency is requested.



NOTE

The GTR will ignore this message while transmitting on the active COM frequency.

B.2.2.2 Set Standby Frequency and Transceiver Function

This message is used to set the Standby frequency as well as the transceiver function.

Message format (GTR 200/200B):

- “GRM”..... Company identifier.
- “C” Message class.
- “16” Message identifier.
- mk Standby frequency: m = MHz, where m = desired MHz frequency - 30h, ranging from 118 to 136 MHz, (i.e. 76h to 88h, A2h); k = (KHz offset / 25KHz) + 30h, ranging from 000 to 975KHz in 25 KHz steps.
- a Transceiver function: N = normal, M = monitor, 0 = unchanged.
- “0” 8.33 KHz offset: (ASCII) 0 = 25 KHz frequency (.000)
- iiii..... Identifier string. Note that if the identifier string is less than four characters, left justify the string and insert spaces for empty characters. An empty identifier string (four spaces) is allowed. Identifiers are restricted to using ASCII characters 0-9 and A-Z.
- f..... Frequency type (see Extended Frequency Type Enumeration).

Example message:

\$PGRMC16G>M0KOJC2<chksm><CR><LF>

This example command would set the standby frequency to 119.350 MHz with an identifier of “KOJC ATIS”, and place the radio in Monitor mode. This is interpreted by noting that the ASCII ‘G’ corresponds with 47h, +30h = 77h, converted to decimal equals 119 for the MHz portion. The KHz portion converts ASCII ‘>’ to 3Eh, -30h yields Eh, x25KHz steps = 350 KHz, with no 8.33 KHz channel offset. The identifier string portion is “KOJC” and the frequency type ‘2’ corresponds to “Automated Terminal Information Station” in the extended frequency type enumeration.

Message format (GTR 225/GNC 255):

- “GRM”..... Company identifier.
- “C” Message class.
- “01” Message identifier.
- mk Standby frequency: m = MHz, where m = desired MHz frequency - 30h, ranging from 118 to 136 MHz, (i.e. 76h to 88h, A2h); k = (KHz offset / 25KHz) + 30h, ranging from 000 to 975KHz in 25 KHz steps.
- a Transceiver function: N = normal, M = monitor, 0 = unchanged.
- “0” 8.33 KHz offset: (ASCII) 0 = 25 KHz frequency (.000)

Example message:

\$PGRMC01KFM0<chksm><CR><LF>

This example command would set the standby frequency to 123.550MHz and place the radio in Monitor mode. This is interpreted by noting that the ASCII ‘K’ corresponds with 4Bh, +30h = 7Bh, converted to decimal equals 123 for the MHz portion. The KHz portion converts ASCII ‘F’ to 46h, -30h yields 16h, x25KHz steps = 550KHz , with no 8.33 KHz channel offset.

Message format (SL30):

- “MRR” Company identifier.
- “V” Message class.
- “29” Message identifier.
- mk Standby frequency: m = MHz, where m = desired MHz frequency - 30h, ranging from 118 to 136 MHz, (i.e. 76h to 88h, A2h); k = (KHz offset / 25KHz) + 30h, ranging from 000 to 975KHz in 25 KHz steps.
- a Transceiver function: N = normal, M = monitor, 0 = unchanged.

Example message:

\$PMRRV29G4N<chksm><CR><LF>

Sets the standby frequency to 119.100MHz, normal receive mode. “G” = 119d - 30h = 77h - 30h = 47h, or an ASCII “G”; “4” = 100 kHz/25 kHz + 30h = 4 + 30h = 34h, or an ASCII “4.”

Message format (SL 40):

- “MRR” Company identifier.
- “C” Message class.
- “01” Message identifier.
- mk Standby frequency: m = MHz, where m = desired MHz frequency - 30h, ranging from 118 to 136 MHz, (i.e. 76h to 88h, A2h); k = (KHz offset / 25KHz) + 30h, ranging from 000 to 975KHz in 25 KHz steps.
- a Transceiver function: N = normal, M = monitor, 0 = unchanged.

Example message:

\$PMRRC01G4N<chksm><CR><LF>

Sets the standby frequency to 119.100MHz, normal receive mode. “G” = 119d - 30h = 77h - 30h = 47h, or an ASCII “G”; “4” = 100 kHz/25 kHz + 30h = 4 + 30h = 34h, or an ASCII “4.”



NOTE

Input frequencies will be checked for validity. An RS-232 serial error message output will be generated if the frequency is invalid, or an 8.33 KHz frequency is requested.

B.2.2.3 Select Squelch Override

This message is used to turn the receiver manual squelch override on and off.

Message format:

“GRM”..... Company identifier.
 “C” Message class.
 “03” Message identifier.
 n Squelch override: (ASCII) 0 = off; 1 = on

Example message:

```
$PGRMC030<chksm><CR><LF>
```

Set the squelch to normal operation.

B.2.2.4 Remote Frequency Lists

The following two messages work together in allowing remotely connected devices to provide frequency lists associated with an airport. The host device should first send the Remote Airport Identifier Name message, followed by a sequence of Remote Frequency Input messages. The list type field is used to tie the two messages together. Up to ten frequency lists are supported, each containing up to twenty entries.

B.2.2.4.1 Remote Airport Identifier Name

This message provides the airport identifier name that is used to identify to the user which airport facility that the list of frequencies is associated with.

Message format (GTR 200/200B):

“GRM”..... Company identifier.
 “C” Message class.
 “04” Message identifier.
 t List type: (ASCII) “0”, “1”,..., “9”
 aaaa Airport Identifier of the frequency list. Note that if the airport is three characters, then the fourth character will be filled with a space. Airport Identifiers are restricted to using ASCII characters 0-9 and A-Z.

Example message:

```
$PGRMC041KOJC<chksm><CR><LF>
```

Airport Identifier to be associated with list #1, Airport Identifier to display is “KOJC”.

Message format (SL 40):

“MRR” Company identifier.
 “C” Message class.
 “04” Message identifier.
 t List type: (ASCII) “0”, “1”,..., “9”
 aaaa Airport Identifier of the frequency list. Note that if the airport is three characters, then the fourth character will be filled with a space. Airport Identifiers are restricted to using ASCII characters 0-9 and A-Z.

Example message:

```
$PMRRC042K81<space><chksm><CR><LF>
```

Airport Identifier to be associated with list #2, Airport Identifier to display is “K81 ”.

B.2.2.4.2 Remote Airport Frequency Input

This message is used to input frequency data for the specified list type.

Message format (GTR 200/200B):

“GRM”..... Company identifier.
 “C”..... Message class.
 “05”..... Message identifier.
 t..... List type: (ASCII) “0”, “1”,..., “9”.
 f..... Frequency type (see Extended Frequency Type Enumeration).
 mk..... Frequency: m = MHz, where m = desired MHz frequency - 30h, ranging from 118 to 136 MHz, (i.e. 76h to 88h, A2h); k = (KHz offset / 25KHz) + 30h, ranging from 000 to 975KHz in 25 KHz steps.
 “0”..... 8.33 KHz offset: (ASCII) 0 = 25 KHz frequency (.000)

Example message:

```
$PGRMC051AG>0<chksm><CR><LF>
```

Airport frequency list “1”, automated surface observing station type, 119.250 MHz.

Message format (SL 40):

“MRR”..... Company identifier.
 “C”..... Message class.
 “05”..... Message identifier.
 t..... List type: (ASCII) “0”, “1”,..., “9”.
 f..... Frequency type (see Legacy Frequency Type Enumeration).
 mk..... Frequency: m = MHz, where m = desired MHz frequency - 30h, ranging from 118 to 136 MHz, (i.e. 76h to 88h, A2h); k = (KHz offset / 25KHz) + 30h, ranging from 000 to 975KHz in 25 KHz steps.

Example message:

```
$PMRRC052<JP<chksm><CR><LF>
```

Airport frequency list “2”, unicom type, 122.800 MHz.

B.2.2.5 Remote Frequency Identifier Lookup Table

The following two messages work together in allowing remotely connected devices to provide frequency identifier lookup information. The host device will send a Set Remote Frequency Table Entry message to add entries to the table, and Delete Remote Frequency Table Entries message to remove entries from the table. The table should be presorted by the host in order of frequency and not have any empty entries between the first and last entry (empty entries at the end are ok). When manually tuning a frequency the table will be checked for a matching frequency, and if found the frequency identifier for the entry will be used. The table can hold at most 255 entries.

B.2.2.5.1 Set Remote Frequency Table Entry

This message is used to add entries to the remote frequency lookup table.

Message format:

“GRM”..... Company identifier.
 “C” Message class.
 “17”..... Message identifier.
 nnn List index (0-254)
 mk Frequency: m = MHz, where m = desired MHz frequency - 30h, ranging from 118 to 136 MHz, (i.e. 76h to 88h, A2h); k = (KHz offset / 25KHz) + 30h, ranging from 000 to 975KHz in 25 KHz steps.
 “0” 8.33 KHz offset: (ASCII) 0 = 25 KHz frequency (.000)
 iiiii..... Identifier string. Note that if the identifier string is less than four characters, left justify the string and insert spaces for empty characters. An empty identifier string (four spaces) is allowed. Identifiers are restricted to using ASCII characters 0-9 and A-Z.
 f..... Frequency type (see Extended Frequency Type Enumeration).

Example message:

```
$PGRMC17025G>0KOJCA<chksm><CR><LF>
```

Add entry 119.250 MHz frequency, KOJC identifier, automated surface observing station type, at table index 25.

B.2.2.5.2 Delete Remote Frequency Table Entries

This message is used to delete entries from the end of the remote frequency lookup table.

Message format:

“GRM”..... Company identifier.
 “C” Message class.
 “18”..... Message identifier.
 nnn Starting list index (0-254)
 sss..... Number of entries to delete, set to “255”. As implemented this parameter is not used. All entries between nnn and the end of the table are deleted.

Example message:

```
$PGRMC18200255<chksm><CR><LF>
```

Delete frequency lookup table entries starting from index 200 to the end of the table.

B.2.2.6 Request Output Data

This message is used to request an output message be sent.

Message format:

“MRR”..... Company identifier.
 “C”..... Message class.
 “06”..... Message identifier.
 ii..... Output identifier of requested message: “03” = software version message.
 dd..... Message data, set to “00”.
 a..... Request type, set to “0”.

Example message:

\$PMRRC0603000<chksm><CR><LF>

Request software version message be sent.

B.2.3 Output Messages

B.2.3.1 Transceiver Status

This message is used to output the current status of the transceiver. This message is sent at a 1Hz rate or whenever the transceiver status changes.

Message format (GTR 200/GTR 225/GNC 255):

“GRM”..... Company identifier.
 “C”..... Message class.
 “01”..... Message identifier.
 mk..... Active frequency: m = MHz, where m = desired MHz frequency - 30h, ranging from 118 to 136 MHz, (i.e. 76h to 88h, A2h); k = (KHz offset / 25KHz) + 30h, ranging from 000 to 975KHz in 25 KHz steps.
 mk..... Standby frequency: m = MHz, where m = desired MHz frequency - 30h, ranging from 118 to 136 MHz, (i.e. 76h to 88h, A2h); k = (KHz offset / 25KHz) + 30h, ranging from 000 to 975KHz in 25 KHz steps.
 a..... Transceiver status:
 I = Intercom (no other status applicable)
 R = Normal receive
 M = Monitor selected
 T = Transmit enable
 S = Stuck mic
 F = Comm failure
 s..... Squelch setting: (ASCII) 0 = automatic; 1 = manual override
 hh..... COM channel spacing: (ASCII) 25 = 25kHz
 o..... Active frequency 8.33 KHz offset: (ASCII) 0 = 25 KHz frequency (.000)
 o..... Standby frequency 8.33 KHz offset: (ASCII) 0 = 25 KHz frequency (.000)

Example Message:

\$PGRMC01G4LFR02500<chksm><CR><LF>

Active frequency is 119.100MHz, the standby frequency is 124.550MHz, unit is receiving, and squelch is automatic.

Message format (SL 40):

- “MRR” Company identifier.
- “C” Message class.
- “01” Message identifier.
- mk Active frequency: m = MHz, where m = desired MHz frequency - 30h, ranging from 118 to 136 MHz, (i.e. 76h to 88h, A2h); k = (KHz offset / 25KHz) + 30h, ranging from 000 to 975KHz in 25 KHz steps.
- mk Standby frequency: m = MHz, where m = desired MHz frequency - 30h, ranging from 118 to 136 MHz, (i.e. 76h to 88h, A2h); k = (KHz offset / 25KHz) + 30h, ranging from 000 to 975KHz in 25 KHz steps.
- a Transceiver status:
 - R = Normal receive
 - M = Monitor receive
 - T = Transmit active
 - S = Stuck mic
- s..... Squelch test setting: (ASCII) 0 = automatic; 1 = test selected

Example message:

\$PMRRC01G4LFR0<chksm><CR><LF>

Active frequency is 119.100MHz, the standby frequency is 124.550MHz, receive function, and squelch is automatic.

Message format (SL 30):

- “MRR” Company identifier.
- “V” Message class.
- “35” Message identifier.
- mk Active frequency: m = MHz, where m = desired MHz frequency - 30h, ranging from 118 to 136 MHz, (i.e. 76h to 88h, A2h); k = (KHz offset / 25KHz) + 30h, ranging from 000 to 975KHz in 25 KHz steps.
- mk Standby frequency: m = MHz, where m = desired MHz frequency - 30h, ranging from 118 to 136 MHz, (i.e. 76h to 88h, A2h); k = (KHz offset / 25KHz) + 30h, ranging from 000 to 975KHz in 25 KHz steps.
- a Transceiver status:
 - R = Normal receive
 - M = Monitor receive
 - T = Transmit active
 - S = Stuck mic
 - F = Comm failure
- s..... Squelch test setting: (ASCII) 0 = automatic; 1 = test selected

Example message:

\$PMRRV35G4LFR0<chksm><CR><LF>

Active frequency is 119.100MHz, the standby frequency is 124.550MHz, receive function, and squelch is automatic.

B.2.3.2 Software Version

This message is used to output the software version string.

Message format:

“MRR”..... Company identifier.
“C”..... Message class.
“03”..... Message identifier.
vvvv Software version in ASCII

Example message:

```
$PMRRC030200<chksm><CR><LF>
```

Software version is 2.00.

B.2.3.3 Communications Error

This message is used to indicate a communications error. When possible, the company identifier and message class will match the company identifier and message class of the offending message.

Message format:

iii..... Company identifier.
c Message class: “05” for COMM messages; “27” for NAV messages.
nn Message identifier.
e Error code: (ASCII)
 0 = input message checksum
 1 = unknown message
 2 = error or mismatch in message data

Example message:

```
$PGRMC051<chksm><CR><LF>
```

Received an unknown message using company ID “GRM” and message class “C”.

APPENDIX C OUTLINE AND INSTALLATION DRAWINGS

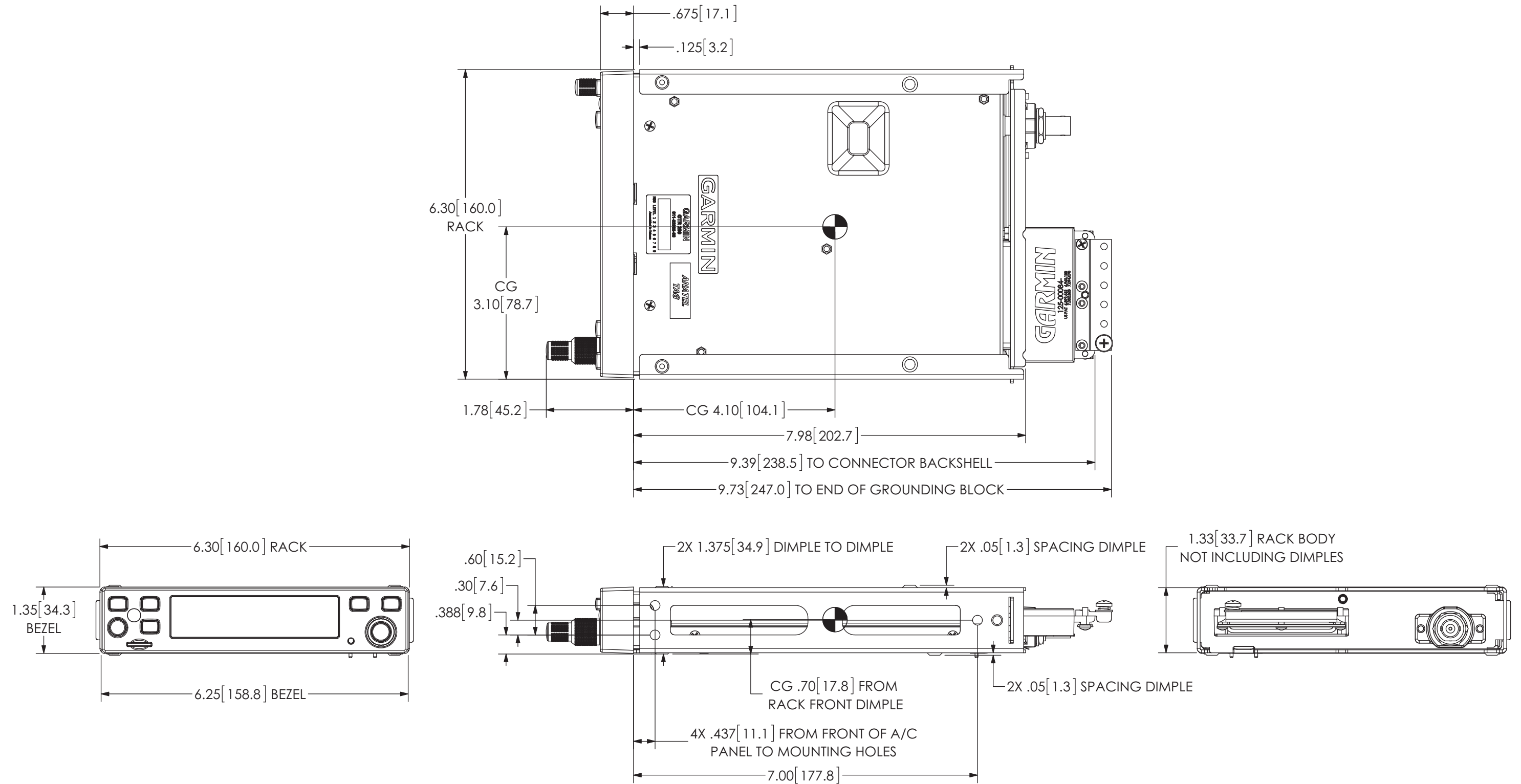

Figure C-1 GTR 200/200B Outline Drawing

APPENDIX C Outline and Installation Drawings

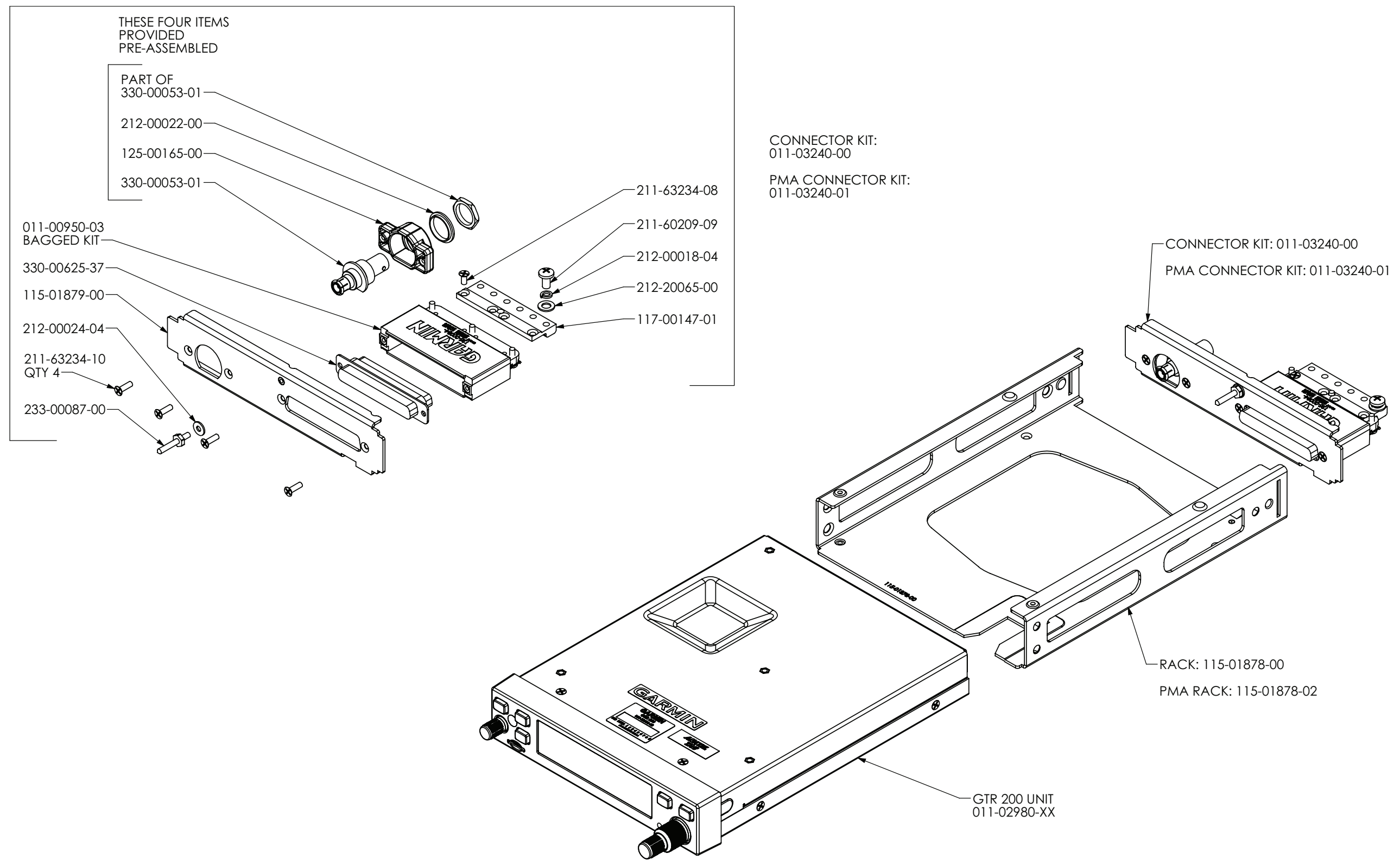

Figure C-2 GTR 200/200B Assembly Drawing

APPENDIX C Outline and Installation Drawings

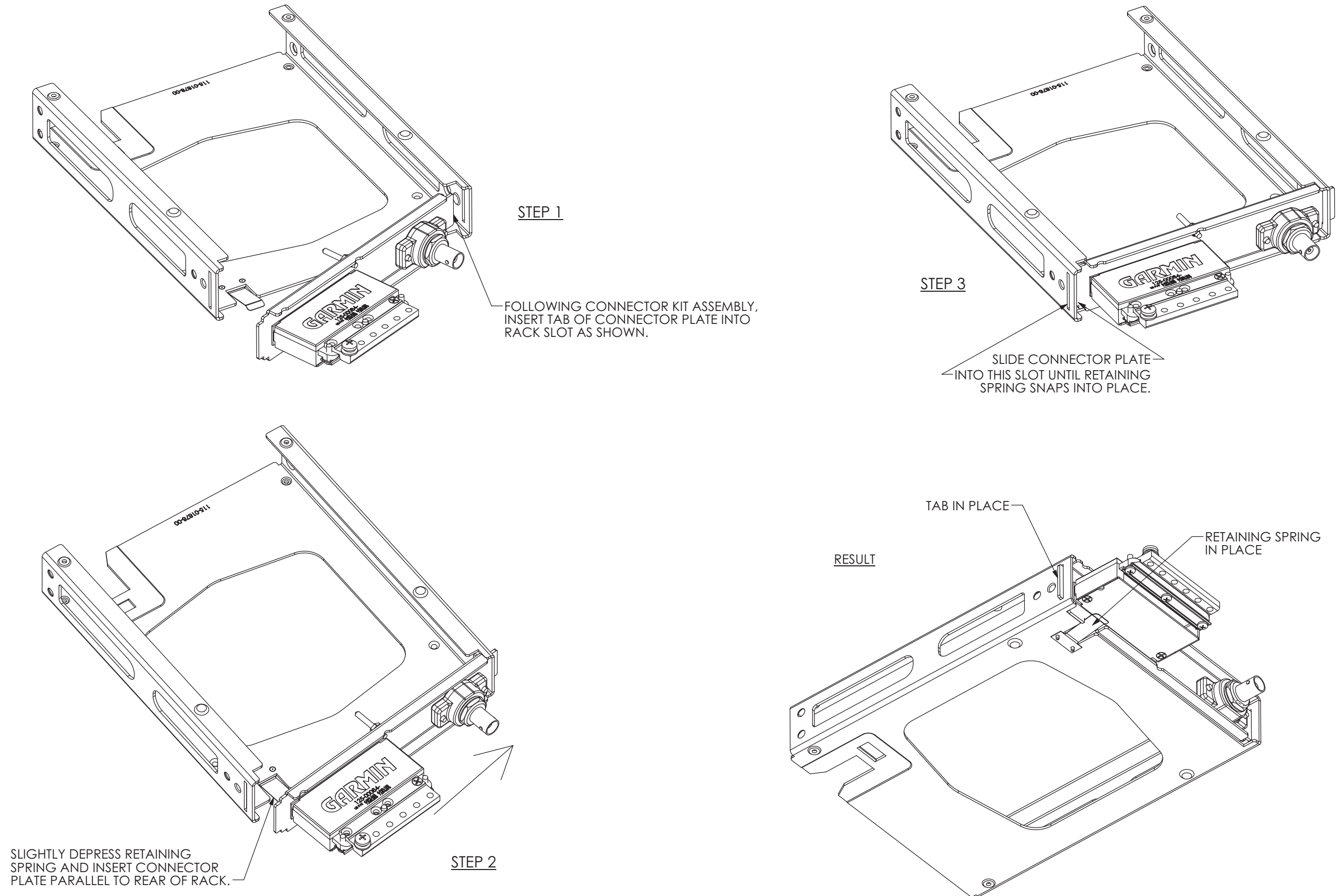

Figure C-3 GTR 200/200B Installation Drawing

APPENDIX C Outline and Installation Drawings

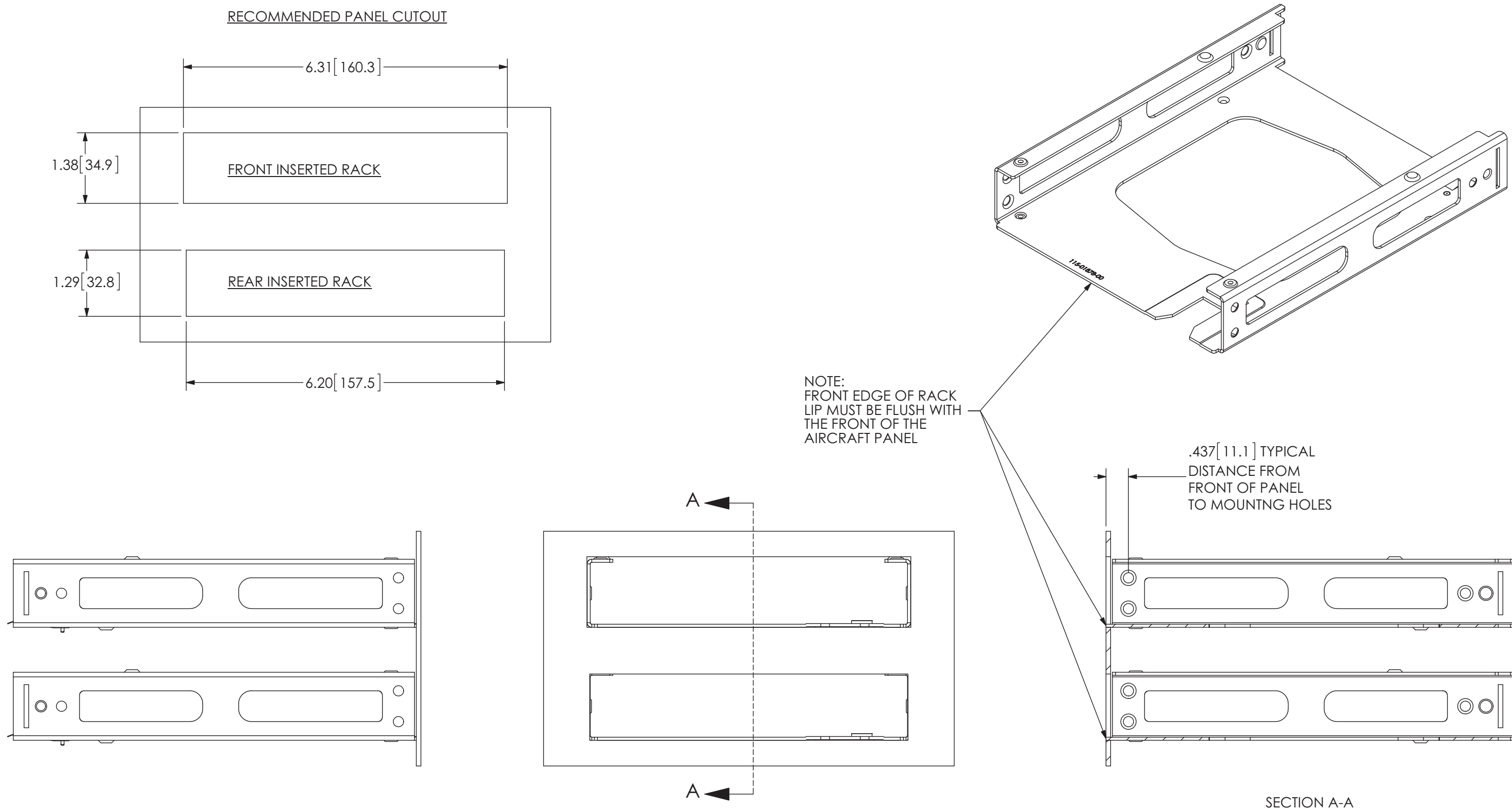
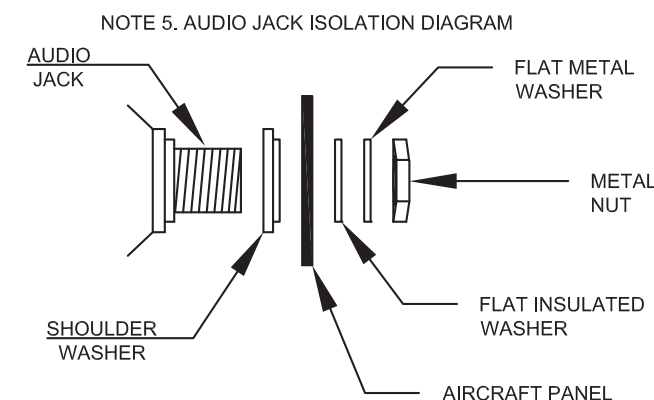
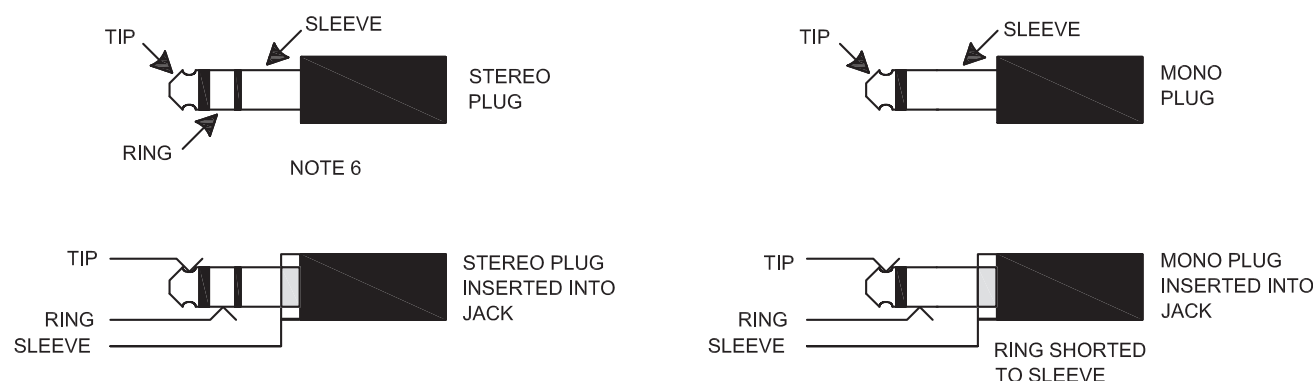
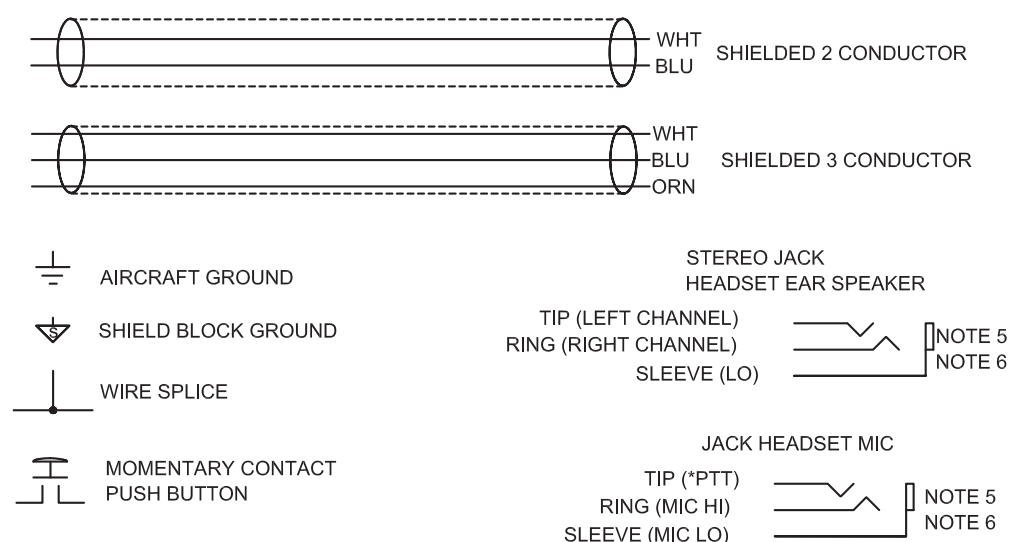

Figure C-4 GTR 200/200B Panel Cutout Drawing

APPENDIX D Interconnect Examples

NOTES:

1. UNLESS OTHERWISE NOTED, ALL STRANDED WIRE MUST CONFORM TO MIL-W-22759/16 OR EQUIVALENT.
2. UNLESS OTHERWISE NOTED, ALL SHIELDED WIRE MUST CONFORM TO MIL-C-27500 OR EQUIVALENT.
3. UNLESS OTHERWISE NOTED, ALL WIRES ARE 22 AWG MINIMUM. POWER AND GROUND WIRES MUST BE 20 AWG
4. SYMBOL DESIGNATIONS AND CONNECTOR GUIDANCE:



5. ISOLATE JACK SLEEVE (MOUNTING NUT AND NUT PLATE) FROM AIRCRAFT CHASSIS.
6. THE HEADSET EAR SPEAKER SLEEVE DIAMETER IS LARGER THAN THE HEADSET MIC SLEEVE DIAMETER.
7. THE CONNECTION BETWEEN PTT AND THE MIC JACK TIP IS REQUIRED IF HAND MICS WILL BE USED. *DENOTES AN ACTIVE LOW SIGNAL.
8. THE FUNCTION OF *DISC1 AND *DISC2 ARE CONFIGURABLE. *DENOTES AN ACTIVE LOW SIGNAL.
9. SPARE AUDIO INPUT.
10. LIGHTING BUS VOLTAGE RANGE IS CONFIGURABLE.
11. IF TWO COM RADIOS ARE INSTALLED THIS INPUT AND OUTPUT CONNECTS TO THE OTHER COM RADIO. *TRANSMIT INTERLOCK IN TO *TRANSMIT INTERLOCK OUT AND *TRANSMIT INTERLOCK OUT TO *TRANSMIT INTERLOCK IN. *DENOTES AN ACTIVE LOW SIGNAL.
12. THIS OUTPUT CAN DRIVE A RECORDING DEVICE IF AN AUDIO PANEL IS NOT CONNECTED. A 3.5 MM JACK IS TYPICALLY USED. ISOLATE JACK SLEEVE (MOUNTING NUT AND NUT PLATE) FROM AIRCRAFT CHASSIS.
13. THE GTR 200 IS CONNECTED AS COM 2. *DENOTES AN ACTIVE LOW SIGNAL.
14. MONO ONLY HEADSET JACK CONNECTION DETAIL.
15. NO NOTE.
16. THE ID STRAP INPUT IS FOR SETTING UP THE GTR 200 TO BE IDENTIFIED IN THE CAN BUS SYSTEM AS EITHER A COM 1 OR A COM 2 RADIO. FOR INSTALLATIONS WITH DUAL GTR 200 RADIOS LEAVE PIN 8 OPEN TO IDENTIFY THE GTR 200 AS COM 1, AND CONNECT PIN 8 TO 27 ON THE SECOND GTR 200 TO IDENTIFY IT AS COM 2 FOR SINGLE INSTALLATIONS DO NOT CONNECT ANYTHING TO PIN 8 (LEAVE OPEN) TO IDENTIFY THE GTR 200 AS COM 1.
17. CONNECTING PINS 25 AND 26 ADDS A 120 OHM TERMINATION TO THE GTR 200 CAN BUS. CONNECT ONLY IF THE GTR 200 IS AT THE END OF THE CAN BUS.

Figure D-1 GTR 200/200B Interconnect Example Notes

APPENDIX D Interconnect Examples

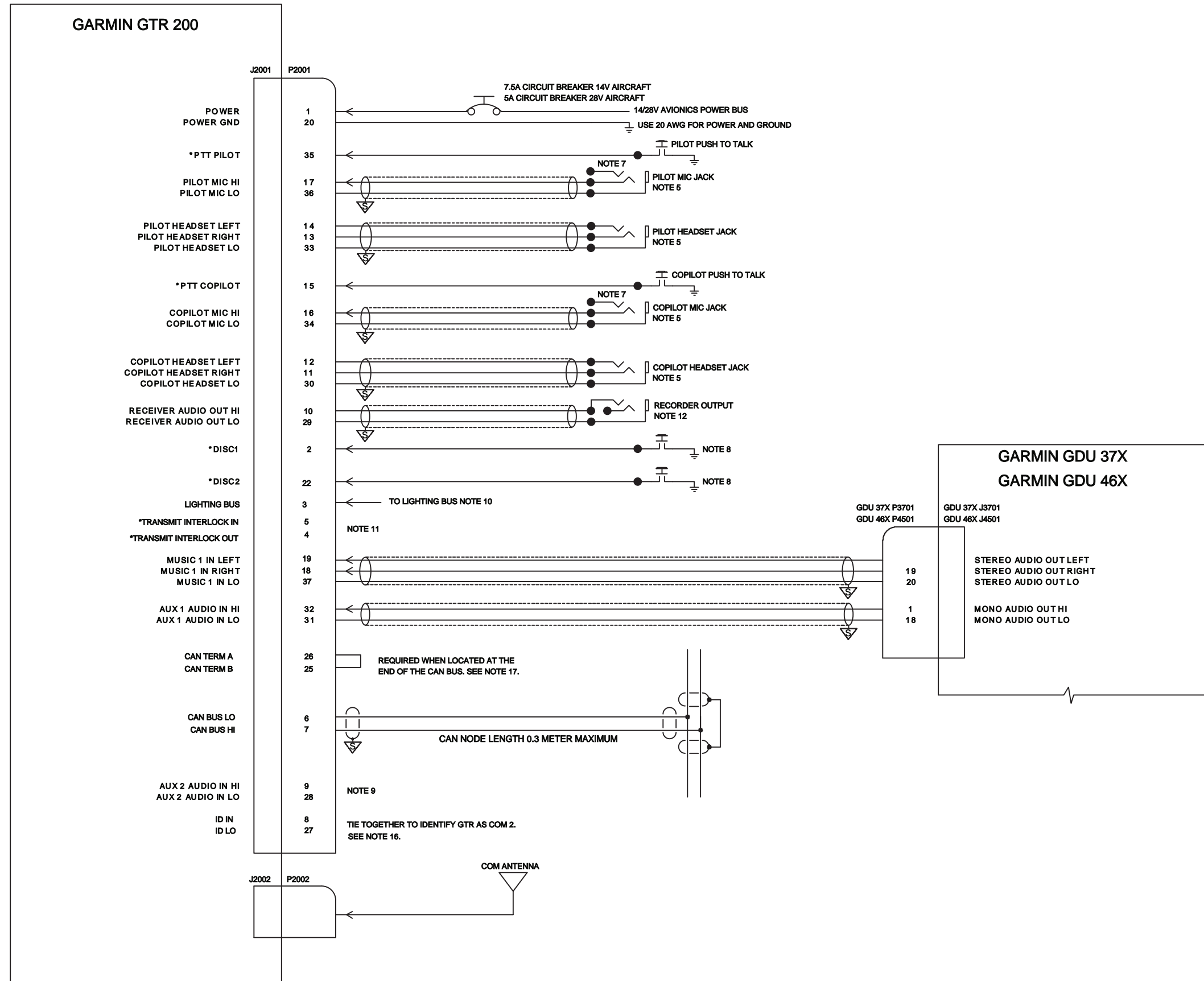

Figure D-2 GTR 200/200B- Power & Ground/Intercom/GDU 37X/46X CAN Bus Interconnect Example

APPENDIX D Interconnect Examples

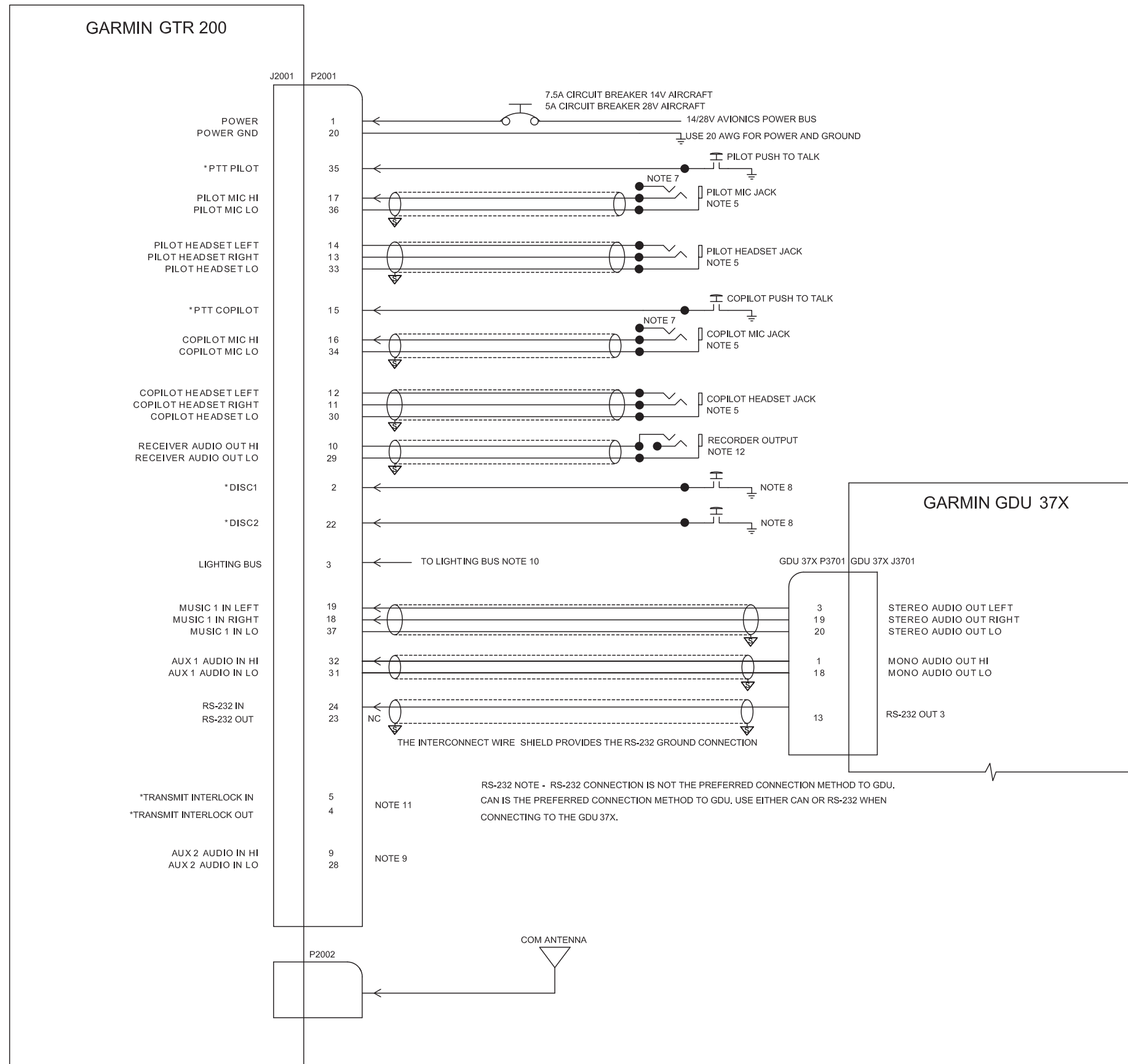

Figure D-3 GTR 200/200B- Power & Ground/Intercom/GDU 37X RS-232 Interconnect Example

APPENDIX D Interconnect Examples

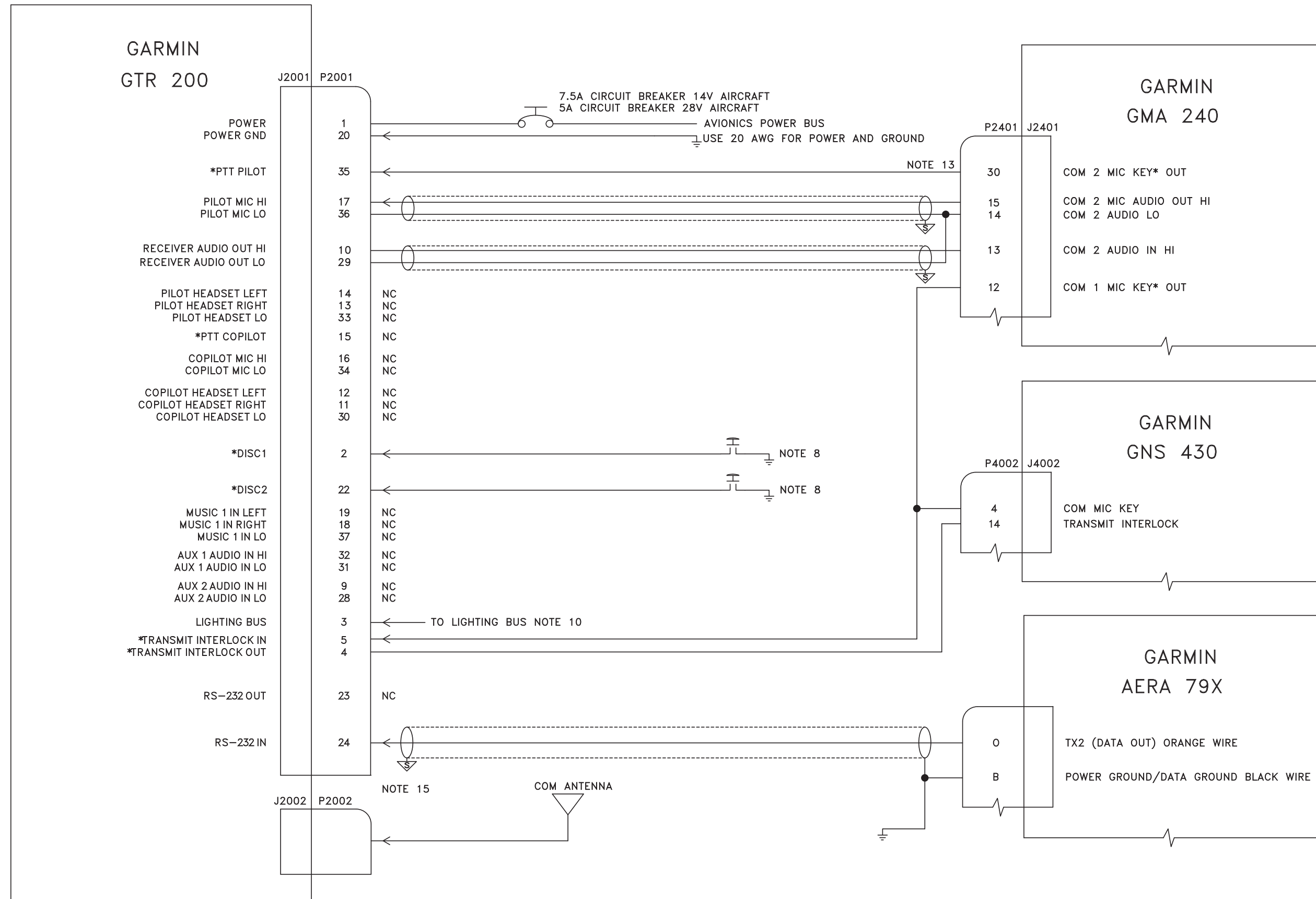

Figure D-4 GTR 200/200B- Power & Ground/GMA 240/GNS 430/aera 79X Interconnect Example

APPENDIX D Interconnect Examples

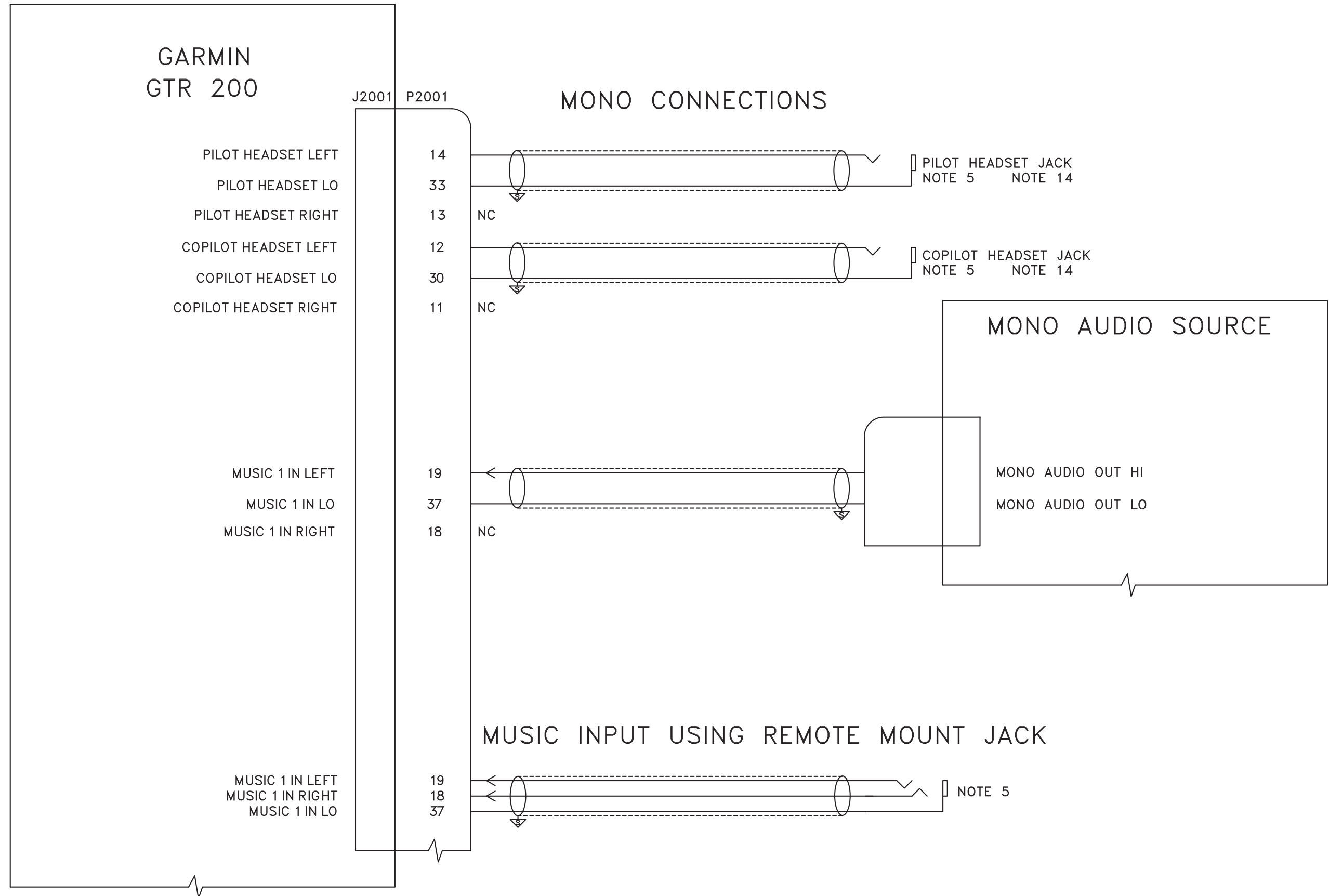

Figure D-5 GTR 200/200B- Mono Audio/Remote Mount Jack Interconnect Example

APPENDIX D Interconnect Examples

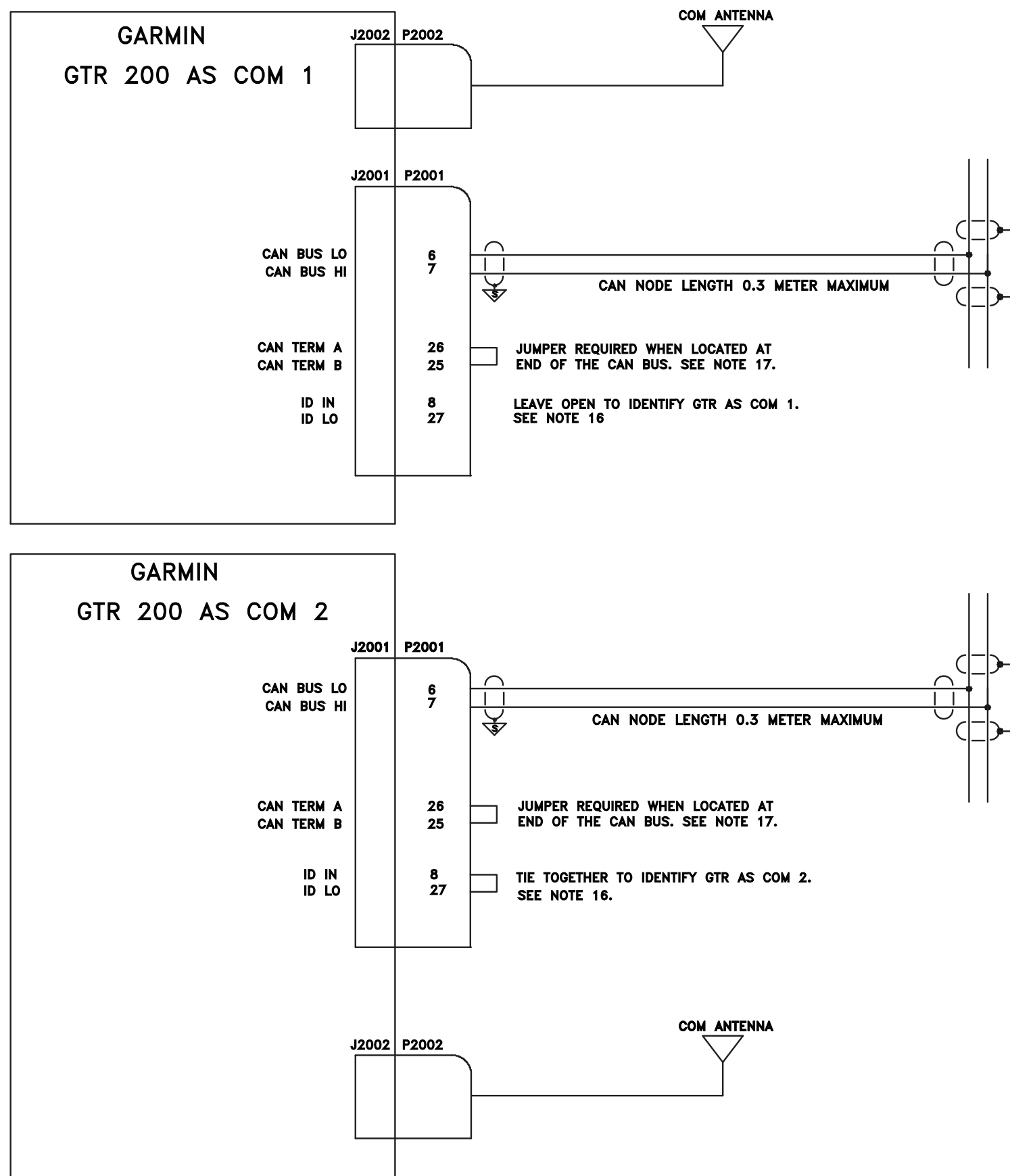

Figure D-6 GTR 200/200B CAN Bus Interconnect Drawing

APPENDIX D Interconnect Examples

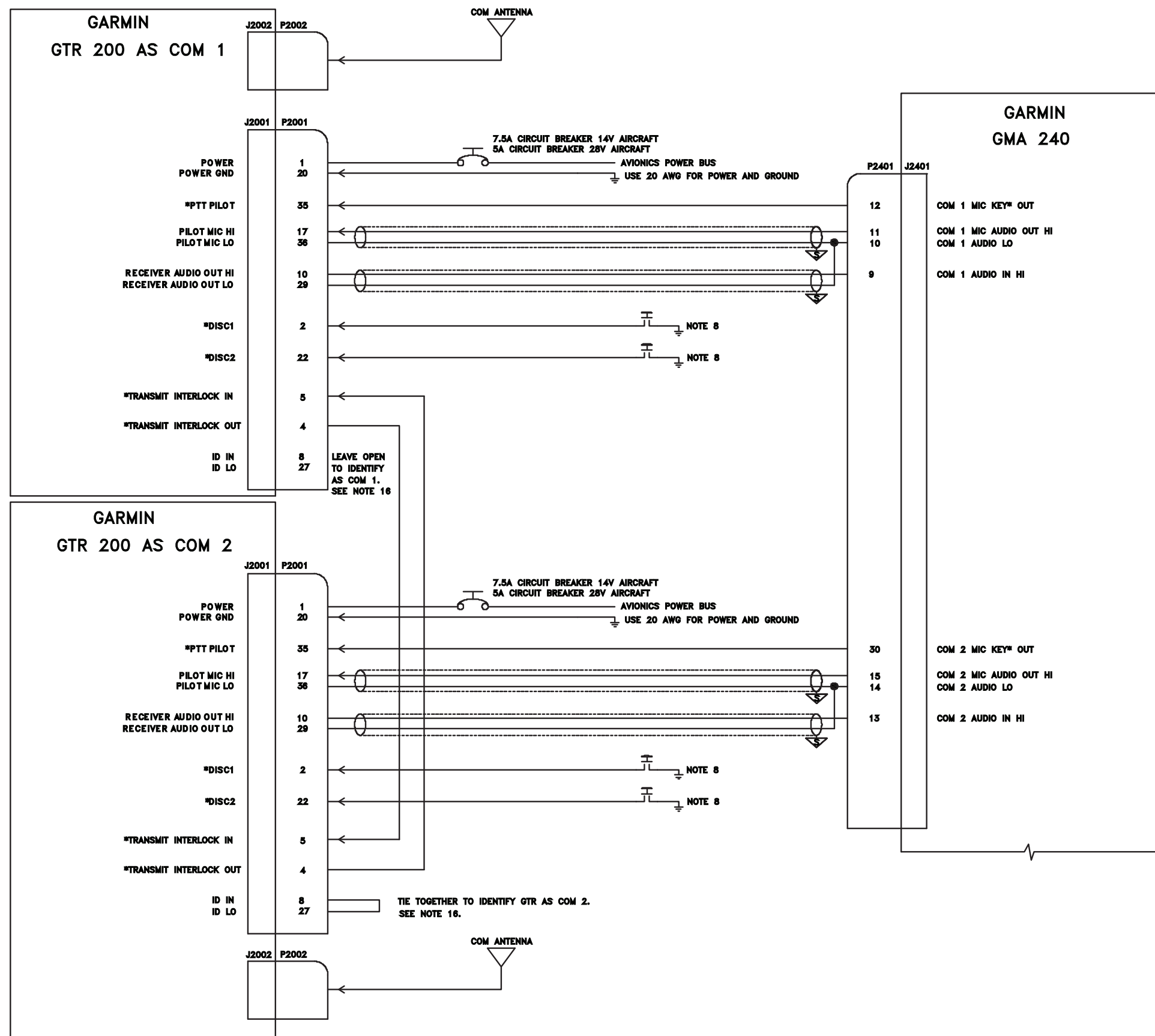

Figure D-7 Dual GTR 200/200B200/200B GMA 240 Interconnect Drawing

APPENDIX D Interconnect Examples

RECOMMENDED LEMO JACK WIRING WHEN USING PREFABRICATED LEMO HARNESS SUCH AS BOSE PART NUMBER 323172-0010

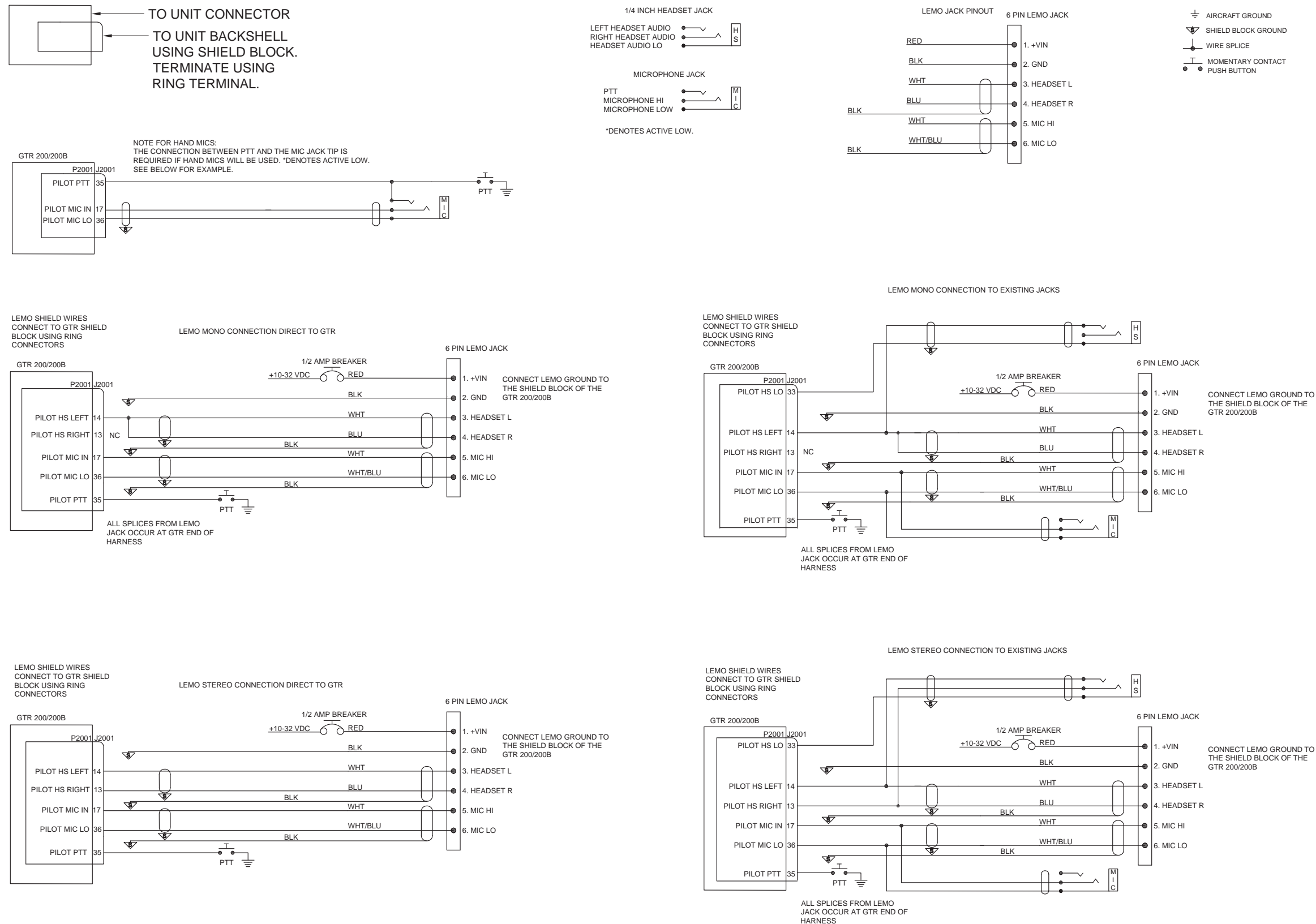

Figure D-8 LEMO Jack Interconnect Drawing

APPENDIX D Interconnect Examples

37	36	35	34	33	32	31	30	29	28	27	26	25	24	23	22	21	20	
MUSIC LO	PILOT MIC LO	PILOT PTT*	COPILOT MIC LO	PILOT HS LO	AUX MONO IN 1	AUX 1 LO	COPILOT HS LO	RECEIVER AUDIO LO	AUX 2 LO	ID LO	CAN TERM A	CAN TERM B	RS232 IN	RS232 OUT	DISC 2*	SPARE	AIRCRAFT GROUND	
19	18	17	16	15	14	13	12	11	10	9	8	7	6	5	4	3	2	1
MUSIC IN LEFT	MUSIC IN RIGHT	PILOT MIC IN	COPILOT MIC IN	COPILOT PTT*	PILOT HS LEFT	PILOT HS RIGHT	COPILOT HS LEFT	COPILOT HS RIGHT	RECEIVER AUDIO OUT HI	AUX MONO IN 2	ID IN	CAN BUS HI	CAN BUS LO	TX INTERLOCK IN*	TX INTERLOCK OUT	LIGHTING BUS IN	DISC 1*	AIRCRAFT POWER

J2001 AS VIEWED LOOKING AT THE REAR OF THE UNIT

Figure D-9 GTR 200/200B - J2001 Connector Layout

GARMIN  **®**