

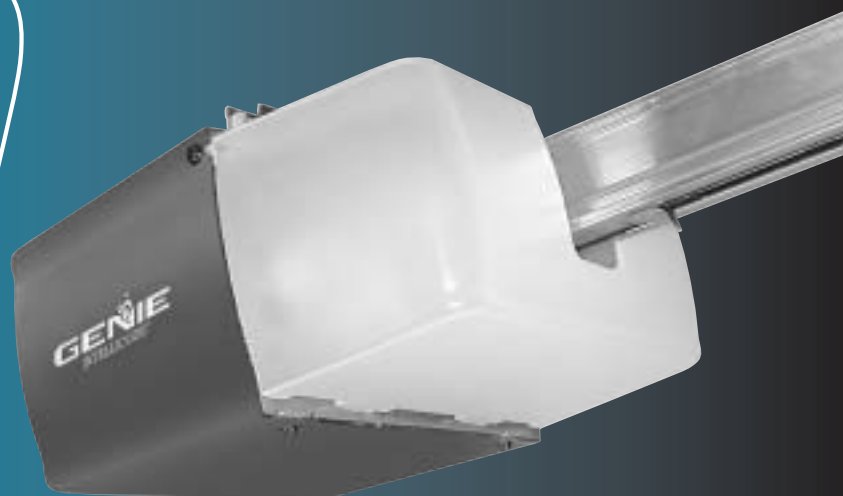

GENIE® SCREW DRIVE



GARAGE DOOR OPENER

Series IS, ISL, IC, H

*Includes INTELICODE® Remote Control
and SERIES II Electronics*

Included Wall Control **MUST** be installed prior to operation of this Garage Door Operator

Safe-T-Beam® Safety Reverse System Must be installed to close door

NOTE: Your Residential Operator comes with a Rail Assembly which is standard for up to a 7 foot 6 inch high door. An extension kit for an 8 foot high door is available.

For Answers and Assistance:

1.800.354.3643

or visit www.geniecompany.com

SAVE THIS MANUAL FOR FUTURE REFERENCE



Things to consider if you are planning to “do-it-yourself.”

Whether you are replacing an existing garage door operator or installing an operator in your garage for the first time, there are some pre-installation issues which need to be addressed.

They are as follows:

The Genie Company recommends that you read and fully understand all information and instructions contained herein before choosing a “do-it-yourself” installation. Any questions should be directed to the Genie Company or an authorized Genie Dealer.

(The issue numbers below refer to the circled numbers in the illustrations on page 3.)

- 1** Check your ceiling where the power head of your new unit will be mounted. Plan how you will be mounting the power head. It is possible that ceiling joists may not be in the exact position needed with respect to the garage door operator. It may be necessary to add an additional bracket and fasteners (not included with your new door operator kit).
- 2** Check the wall directly above the garage door. The door operator’s header bracket must be securely fastened to this wall. Ensure that the structure will provide a strong mounting location.
- 3** Check to see if the mounting location for the Safe-T-Beam® System (STB) is clear from obstruction and has a wood surface available for attaching the STB brackets. The brackets may be attached to concrete if necessary but extra tools and special fasteners (not supplied) will be required.
NOTE: 1-1/2" STB bracket adapters are available through your local Genie Dealer.
- 4** Is your garage door made of light-weight steel, aluminum, fiberglass or glass panels? Additional support bracing must be added to these type doors. If this is the case, please contact the door distributor or manufacturer so that they can furnish you with a “bracing kit.”
- 5** You need a 110-120 Volt power supply available. The outlet should be no more than 3 feet from the power head once it is mounted. (The cord is 4 ft. in length.) SEE WARNING BELOW.
- 6** To avoid damage to your door and/or operator, make sure you disable any door locks prior to installing your operator.
- 7** Ensure that your door is properly balanced and moving freely. SEE WARNING BELOW.
- 8** (NOT SHOWN) If your garage does not have a separate entry door, you should consider an emergency release kit (GER-2) for installation on your garage door. See page C at the center of this manual.

⚠ WARNING

If your door sticks, binds, or is out of balance, have it adjusted by a professional. Door springs, cables, pulleys, brackets and associated hardware are under extreme tension and can cause serious injury or death.

⚠ WARNING

DO NOT USE AN EXTENSION CORD! Extension cords can cause dangerous overheating conditions.
DO NOT USE A PORTABLE GENERATOR! This product is designed to operate on standard house current. Do not use alternate power supplies.



HomeLink® is a universal transceiver (a combined transmitter and receiver), that provides a convenient way to replace up to three hand-held radio-frequency (RF) transmitters used to activate devices such as gate operators, garage door openers, entry door locks, security systems and even home lighting. Additional HomeLink® information can be found at: www.homelink.com or by calling 1.800.355.3515.

TYPICAL SECTIONAL DOOR INSTALLATION

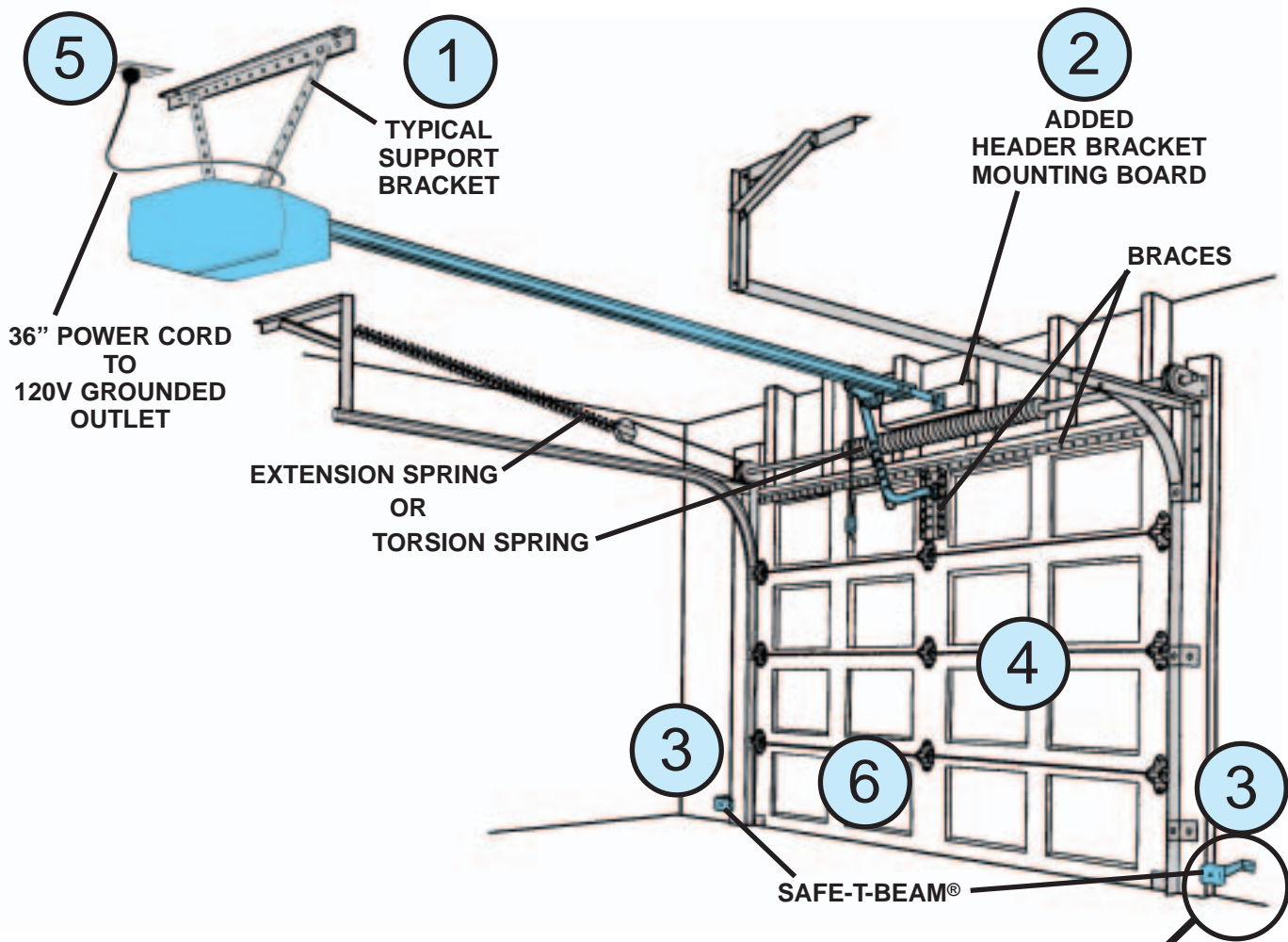

3

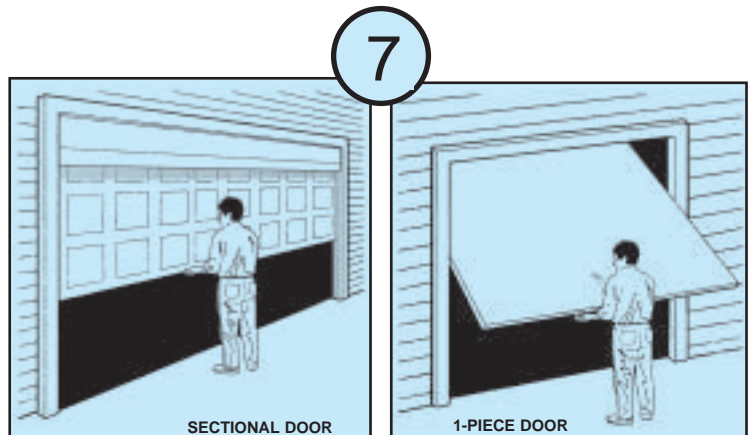
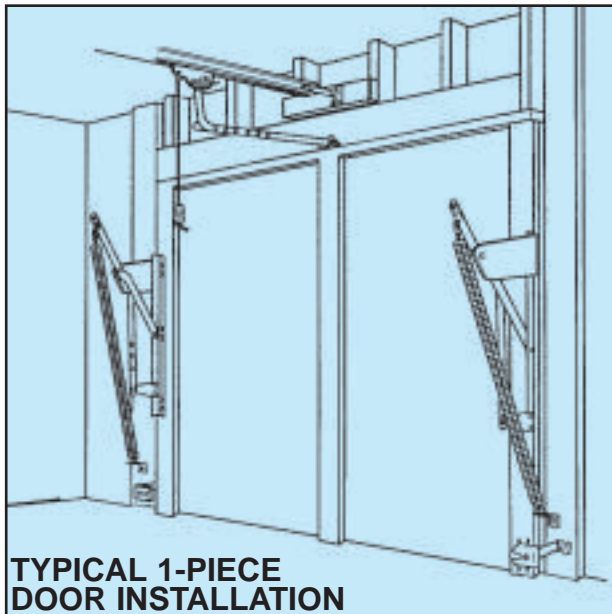
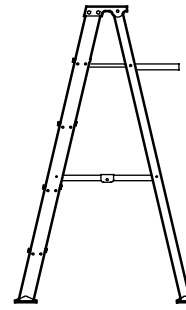

TABLE OF CONTENTS

SECTION	PAGE
PRE-INSTALLATION CHECK LIST	2-3
TOOLS REQUIRED	4
SAFETY FEATURES	4
OPERATIONAL FEATURES	5
PARTS LISTS AND ILLUSTRATIONS	5-8
POWER HEAD	5
ONE-PIECE RAIL	6
THREE-PIECE RAIL	7
FASTENERS AND ACCESSORIES	8
SAFETY INFORMATION	9
PRE-INSTALLATION WARNING	9
1 MAIN ASSEMBLY	10-14
2 INSTALLATION	15-21
3 SAFE-T-BEAM®	22-23
4 WALL CONTROL	24-25
5 LIGHT & LIGHT LENS	25
6 CONNECTING POWER	26
7 SETTINGS	27-28
CONTACT REVERSE	28
8 BATTERY & VISOR CLIP	28
9 PROGRAMMING REMOTE CONTROLS	29
TRANSMITTER COMPLIANCE STATEMENT	30
IMPORTANT SAFETY INSTRUCTIONS	30
10 MAINTENANCE & TROUBLESHOOTING	31-32
11 WIRING DIAGRAM	A
WARRANTY B	
ACCESSORIES ORDER FORM	C

RECOMMENDED TOOLS



Step ladder



Carpenter's level



Adjustable wrench



Pencil



Drill



Wire strippers



5/32" Drill Bit



Ratchet



Phillips screwdriver



7/16" and 9/16" Sockets



Tape measure

SAFETY FEATURES *(varies by model)*

Safe-T-Beam® (STB) Non-Contact Reversing System

Places an invisible beam across door opening that reverses the door during down travel to the fully open position if anything passes through beam.

Safe-T-Reverse® Contact Reversing System

Automatically stops and reverses a closing door within 2 seconds of contact with an object.

Safe-T-Stop® Timed Reversed System

Automatically opens a closing door, if door does not close within 30 seconds.

Force Guard® Control

Used to set the force required for opening and closing door. For maximum safety, set the minimum force required to fully open and close door.

Automatic Lighting System

Two light bulbs up to 60 Watts max. each are used for safer entries and exits. The light turns on when door is activated and automatically turns off 4.5 minutes later.

Manual Emergency Release

Allows the garage door to be opened or closed manually for emergencies or maintenance.

[1] Power Head Assembly

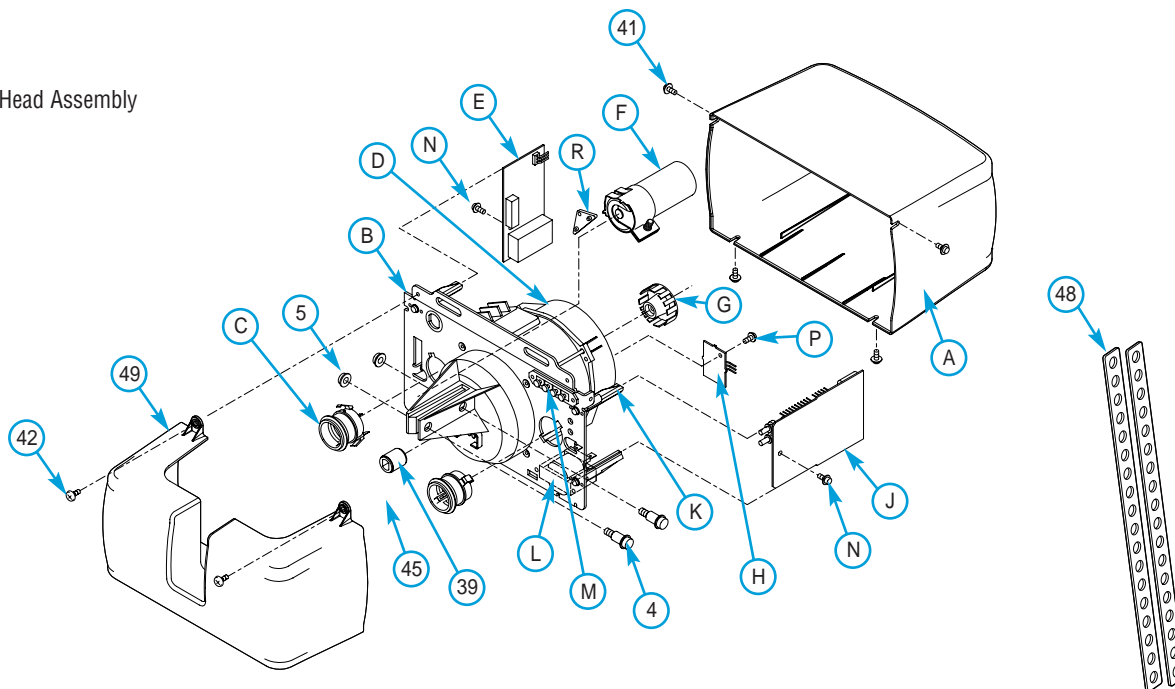

5

POWER HEAD PARTS LIST

Item	Part Name
1	Power Head Assembly
A	Cover (By Series/Model)
B	Front Plate Assembly
C	Light Socket
D	Motor Parts
E	Receiver Assembly
F	Capacitor (By Series/Model)
G	Opto Wheel
H	Opto-Luctor Assembly
J	Sequencer Assembly
K	Circuit Board Bracket
L	Transformer

Item	Part Name
M	Terminal Strip
N	No. 8-32 x 1/2" Hex Washer Head Screw
P	No. 8-32 x 3/8" Slot Hex Washer Head Screw
R	Capacitor Isolator
45	Bumper
4	1/4-20 Shoulder Bolt
5	1/4" Flange Nut
39	Coupler
41	No. 8-32 x 3/8" Phillips Hex Head Screw
42	No. 8-32 x 3/8" Phillips Pan Head Screw
48	Mounting Straps
49	Light Lens

OPERATIONAL FEATURES

INTELLICODE® Access Security System

Improves security of door operator by continuously changing the access code each time the remote control is used. The door operator responds to each new code only once. An access code copied from a working system and tried again will not control the door operator.

INTELLICODE® 1-Button Remote Control

Controls door operator by allowing the garage door to be opened and closed remotely.

INTELLICODE® Multi-Button Remote Control

Operates multiple Intellicode® equipped door operators.

Lighted Wall Button (some models)

Operates door operator from inside garage. DO NOT use with lighted wall console.

Wall Console (some models)

Works like a lighted wall button but includes a Vacation Lock Switch that disables all controls. LED indicator shows whether system is powered, locked or unlocked. Makes console easy to find in dark. Controls door opener from inside garage. Independent light control allows convenient manual control of the Automatic Lighting System. DO NOT use with lighted wall button.

NOTE: All items may not be supplied with your garage door operator.

[2] 1-Piece Rail & Screw Assembly

6

NOTE: The operator will not function properly unless the **Safe-T-Beam®** sensors are installed and the **force controls** adjusted.

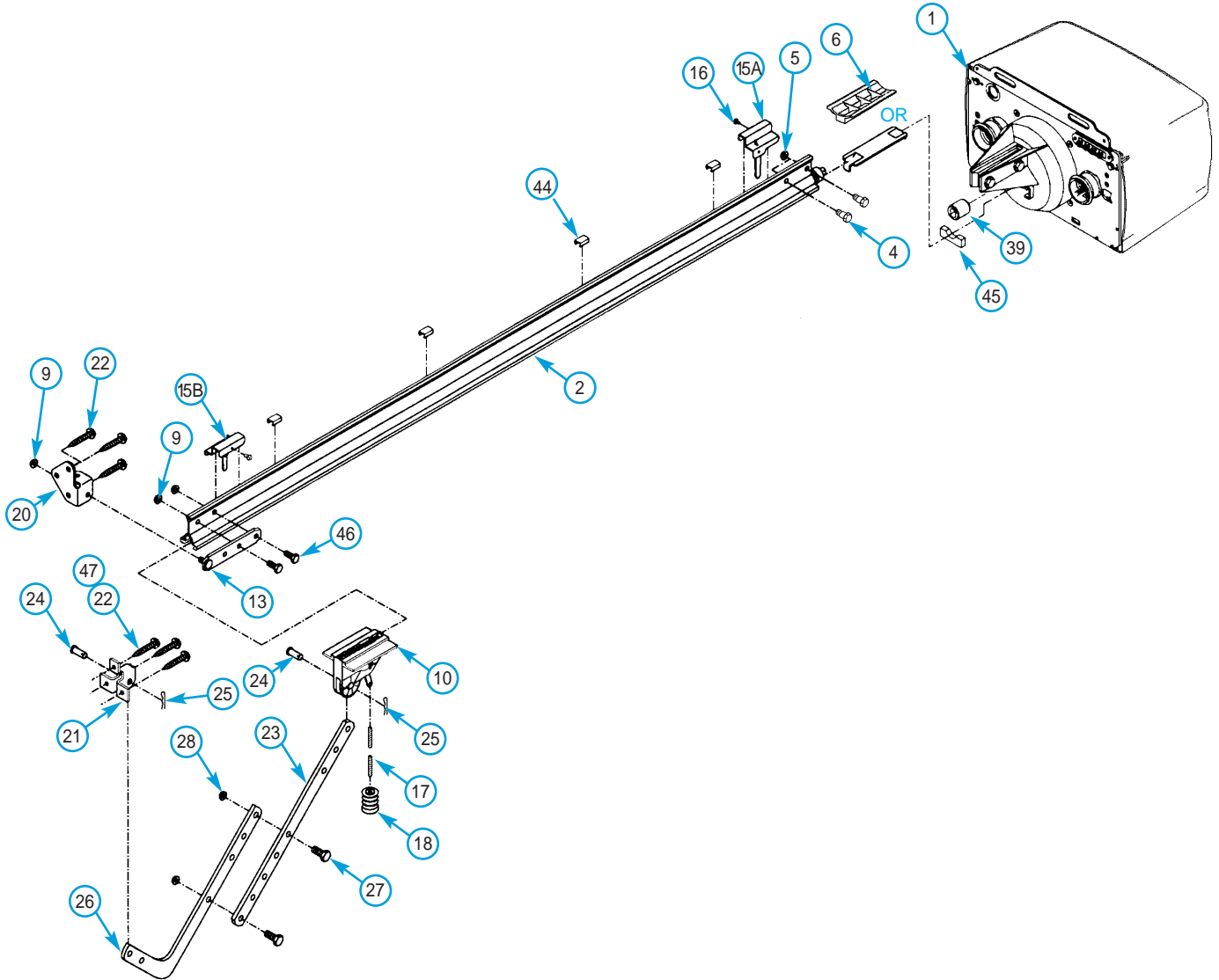

PARTS LIST

Item	Part Name	Parts Required	
		1 Piece	3-Piece
1	Power Head Assembly (See page 5)	1	1
2	Rail Assembly (1 piece)	1	
3	Rail Assembly (3 piece)		1
3A	First Rail Section		1
3B	Middle Rail Section		1
3C	End Rail Section		1
4	1/4-20 Hex Hd Shoulder Bolt	2	2
5	1/4"-20 Hex Flange Nut	2	2
6	Carriage Stop	1	1
7	Rail Clamps		4
8	5/16" Hex Shoulder Bolt		8
9	5/16" Hex Flange Nut	5	13
10	Carriage Assembly	1	1
11	Collar		2
12	Retaining Clip		2
13	Rail Strap	1	1
15A	Open Limit Switch Assembly (Grey)	1	1

PARTS LIST

Item	Part Name	Parts Required	
		1 Piece	3-Piece
15B	Close Limit Switch Assembly (Brown)	1	1
16	No. 8-32 x 3/8" Hex Head Screw	2	2
17	Emergency Release Cord	1	1
18	Emergency Release Knob	1	1
19	Emergency Release Tag	1	1
20	Header Bracket	1	1
21	Door Bracket	1	1
22	1/4" x 2" Lag Screw	8	8
23	Straight Door Arm	1	1
24	Clevis Pin	2	2
25	Cotter Pin	2	2
26	Curved Door Arm	1	1
27	3/8" x 7/8" Hex Head Bolt	2	2
28	3/8" Hex Flange Nut	2	2
29	Wire	≈95ft	≈95ft
30	Insulated Staple	≈30	≈30
31	Wall Button	varies	varies

[3] 3-Piece Rail & Screw Assembly

NOTE: The operator will not function unless the **Safe-T-Beam®** system is installed and the **force controls** are properly set.

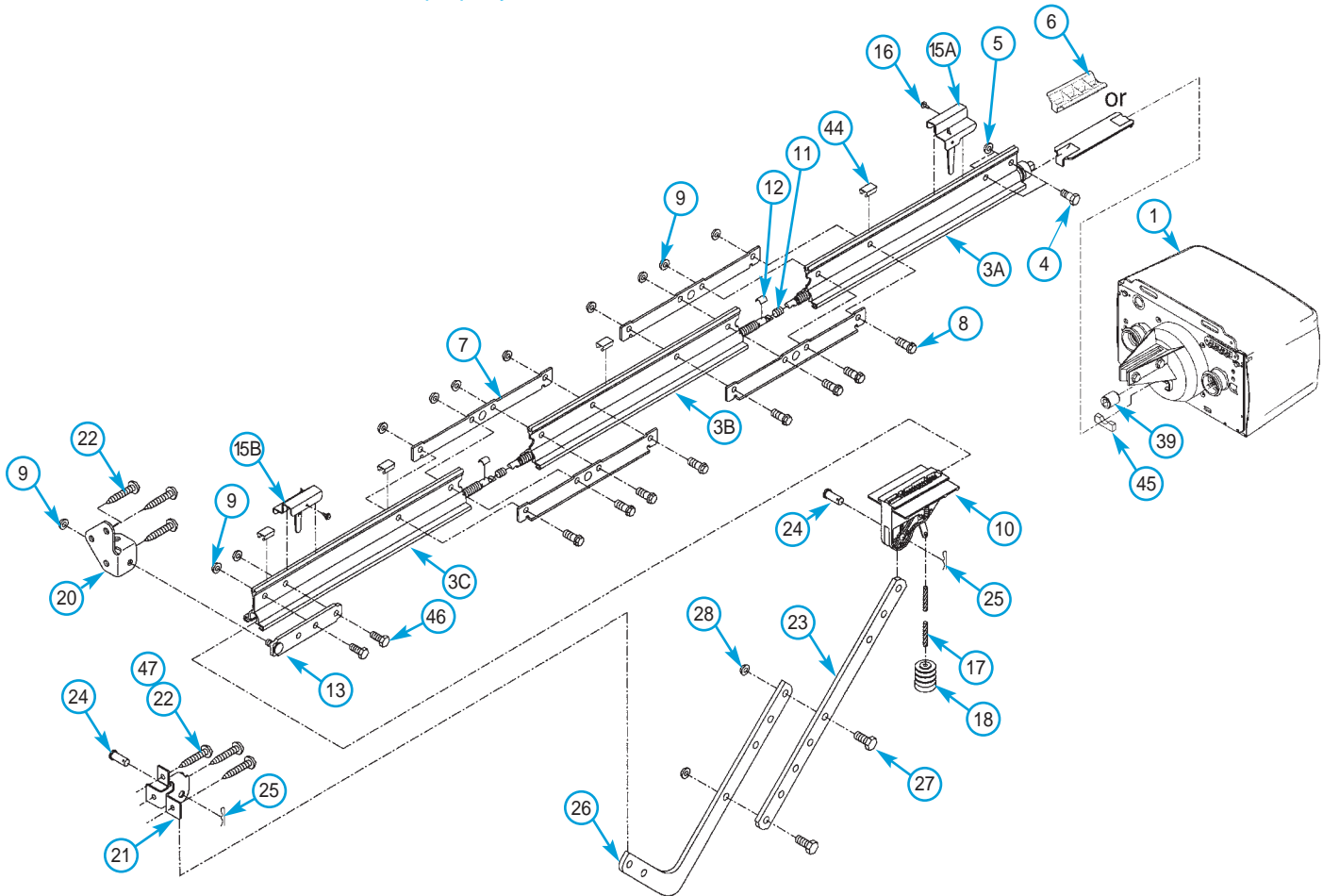

PARTS LIST





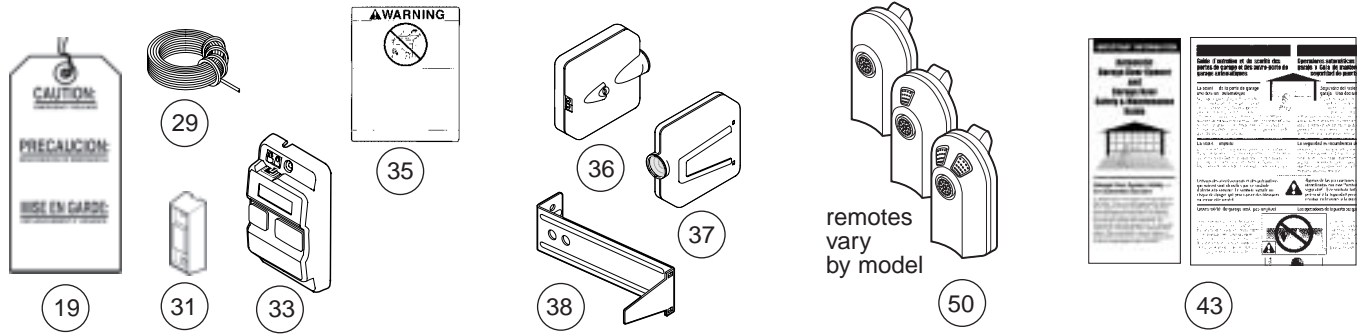



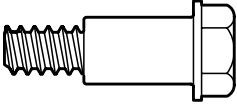
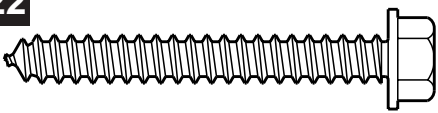
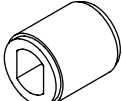

Item	Part Name	Parts Required	
		1 Piece	3-Piece
33	Wall Console	varies	varies
34	#6 x 1-1/4" Pan Head Screw	2	2
35	Entrapment WARNING Label	1	1
36	Safe-T-Beam (STB) System Sensor (Green LED)	1	1
37	Safe-T-Beam (STB) System Source (Red LED)	1	1
38	Safe-T-Beam (STB) System Bracket	2	2
39	Coupler	1	1
40	No. 10 x 1 1/4" Phillips Hex Head Screw	4	4
41	#8 x 3/8" Hex Head Screw	4	4
42	#8 x 3/8" Pan Head Screw	2	2
43	Safety & Maintenance Guide	1	1
44	Wire Clip	4	4
45	Bumper	1	1
46	5/16" x 3/4" Hex Head Bolt	5	5
47	1/4-20 x 3/4" Self-tapping Screw	3	3
48	Mounting Straps		2
49	Light Lens (Shown on page 5)	1	1
50	Remote Control	varies	varies

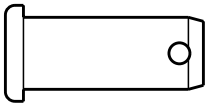
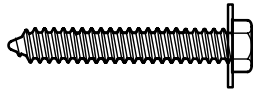
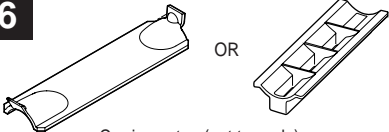
8

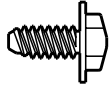
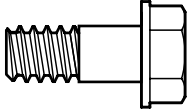
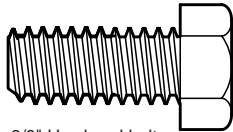
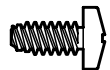
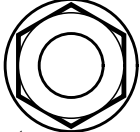
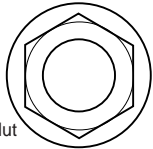
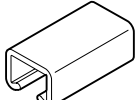

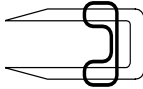
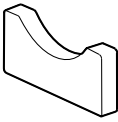
NOTE: Accessories vary by model.

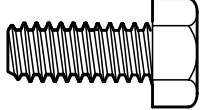
FASTENERS - Shown full size. See Parts List for description.

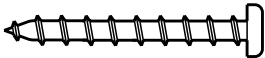
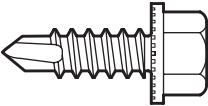
<p>4</p>  <p>1/4" Shoulder bolt w/flange</p>	<p>22</p>  <p>1/4" x 2" Lag screw</p>	<p>39</p>  <p>Coupler</p>
<p>5</p>  <p>1/4" Flange nut</p>	<p>24</p>  <p>Clevis pin</p>	<p>40</p>  <p>#10 x 1-1/4" Phillips hex head screw</p>
<p>6</p>  <p>Carriage stop (not to scale)</p>	<p>25</p>  <p>Cotter pin</p>	<p>41</p>  <p>#8 x 3/8" Hex flange head screw</p>
<p>8</p>  <p>5/16" Shoulder bolt w/flange</p>	<p>27</p>  <p>3/8" Hex head bolt</p>	<p>42</p>  <p>#8 x 3/8" Pan head screw</p>
<p>9</p>  <p>5/16" Flange nut</p>	<p>28</p>  <p>3/8" Nut</p>	<p>44</p>  <p>Wire clip</p>
<p>11</p>  <p>Collar</p>	<p>30</p>  <p>Insulated staple</p>	<p>45</p>  <p>Rubber bumper</p>
<p>12</p>  <p>Clip</p>	<p>32</p>	<p>46</p>  <p>5/16" x 3/4" Hex head bolt</p>
<p>16</p>  <p>#8-32 x 3/8" Hex head screw</p>	<p>34</p>  <p>#6 x 1-1/4" Pan head screw</p>	<p>47</p>  <p>1/4"-20 Self-drilling screw</p>

SAFETY INFORMATION

OVERVIEW OF POTENTIAL HAZARDS

Garage doors are large, heavy objects that move with the help of springs under high tension and electric motors. Since moving objects, springs under tension, and electric motors can cause injuries, your safety and the safety of others depend on you reading the information in this manual. If you have questions or do not understand the information presented, call your nearest service representative.

In this section and those that follow, the words **Danger**, **Warning**, and **Caution** are used to emphasize important safety information.



The word:

▲ DANGER means that severe injury or death will result from failure to follow instructions.

▲ WARNING means that severe injury or death can result from failure to follow instructions.

▲ CAUTION means that property damage or injury can result from failure to follow instruction.

The word **NOTE** is used to indicate important steps to be followed or important considerations.

POTENTIAL HAZARD	EFFECT	PREVENTION
 MOVING DOOR	WARNING: Can Cause Serious Injury or Death	Keep people clear of opening while door is moving. Do Not allow children to play with the door operator. Do Not operate a door that jams or one that has a broken spring.
 ELECTRICAL SHOCK	WARNING: Can Cause Serious Injury or Death	Turn off power before removing operator cover. When replacing cover, make sure wires are not pinched or near moving parts. Operator must be properly grounded.
 HIGH SPRING TENSION	WARNING: Can Cause Serious Injury or Death	Do Not try to remove, repair or adjust springs or anything to which door spring parts are fastened, such as, wood blocks, steel brackets, cables or other like items. Repairs and adjustments must be made by a trained service person using proper tools and instructions.

FILL THIS IN AT TIME OF INSTALLATION FOR YOUR OWN RECORDS, SO THAT IT WILL BE AVAILABLE IF YOU EVER NEED TO CALL US.

Date Purchased MM / DD / YY
WK / YY / PI (See Fig. 1-1)
 Serial Number _____
 Operator Model _____
 Dealer Name _____
 Dealer Address _____
 City _____
 State _____
 Zip _____

NOTE: Please keep original or photocopy of your sales receipt with this manual for future reference should service ever be required.

PRE-INSTALLATION WARNING

IMPORTANT INSTALLATION INSTRUCTIONS

9

▲ WARNING:

To reduce the risk of severe injury or death:

- 1. READ AND FOLLOW ALL SAFETY, INSTALLATION AND OPERATION INSTRUCTIONS.** If you have any questions or do not understand an instruction, call your service representative.
- 2. Do Not install Opener on an improperly balanced door.** An improperly balanced door may cause severe injury. Repairs and adjustments to cables, spring assemblies, and other hardware must be made by a trained service person using proper tools and instructions.
- 3. Remove all handles and ropes, and disable all locks** connected to the door before installing the Opener.
- 4. Install door Opener 7' or more above the floor.** Mount the emergency release knob 6' above the floor.
- 5. Do Not connect the Opener to the power source until instructed to do so.**
- 6. Locate the Wall Control:**
 - Within sight of the garage door.
 - At a minimum height of 5', so small children cannot reach it.
 - Away from all moving parts of the garage door.
- 7. Install the entrapment WARNING label** next to the wall button or console. Install the emergency release tag on the emergency release.
- 8. The operator must reverse** when the door contacts a 1 1/2" high object on the floor at the center of the doorway. This is the size of a 2" x 4" board laid flat.

Visit our website at:
www.geniecompany.com

SAVE THESE INSTRUCTIONS

OPEN BLUE PARTS BAG

NOTE: 3-piece rail assembly is for doors up to and including 7 feet 6 inches high. An extension for 8 feet doors is available.

1. Set power head so that front panel (with end of shaft and rail attachment flange) is facing up. Fig. 1-1.

NOTE: If you have this type Carriage Stop, skip Step 2. DO NOT install Bumper.

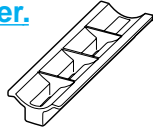

2. Install bumper [45].

- Peel protective paper from glue side of bumper.
- Stick bumper into position as shown. Fig. 1-1.

3. Install coupler [39].

- Place coupler over end of shaft.
- Turn it as needed until it engages with shaft. (It will drop down over end of shaft and will no longer turn freely. Fig. 1-1.

4. Set power head on its bottom. Fig. 1-4.

CAUTION

Drive screws can slide out of rail sections. Keep rail sections level until operator is fully assembled.

5. Attach 1-piece rail or “first” rail section [3A] of 3-piece rail to power head.

- (3-piece only) Select “first” rail section. (It has protective cardboard sleeve over end of screw.) Fig. 1-2.
- (3-piece only) Remove cardboard sleeve.
- Slide end of screw out about 5 inches. Fig. 1-3.
- Place bearing end of screw against coupler. Fig. 1-4.
- Turn screw until it engages with coupler.
- Slide rail section into rail attachment flange until holes in rail match up with holes in flange.
- Secure “first” rail section with 2 bolts [4] and 2 nuts [5], hand tight only. Fig. 1-5.
- For 1-piece rail, skip to step 8.

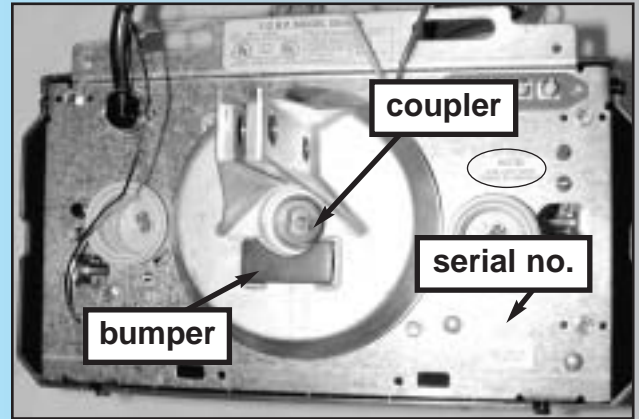
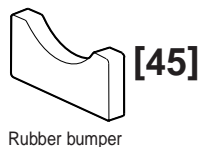
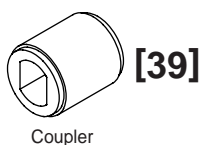

Fig. 1-1



Fig. 1-2

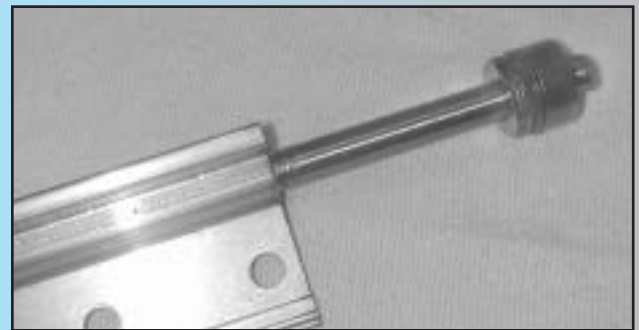

Fig. 1-3



Fig. 1-4

6. Attach “middle” rail section [3B].
- Select “middle” rail section. (This section looks identical on both ends with each set of holes being about 4 inches apart.) **Fig. 1-6.**
 - Find arrows stamped into side of rail. **Fig. 1-7.**
 - Align rail so arrows point away from power head.
 - Slide screw toward power head so it sticks out end of rail section about 2 inches.



Fig. 1-5

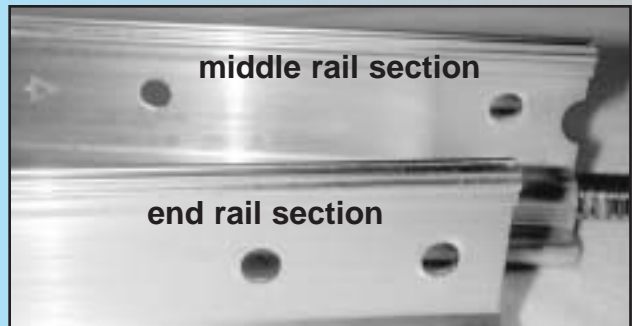
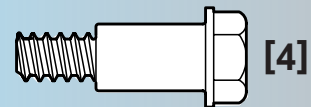

Fig. 1-6



Fig. 1-7



1/4" Shoulder bolt w/flange



1/4" Flange nut

- Slide a collar [11] over exposed end of screw on “middle” rail as far as it will go. **Fig. 1-8.**
- Engage “hook” on “middle” rail with “hook” on “first” rail section. **Fig. 1-9.**
- Slide collar toward power head so that it now covers hooks. **Fig. 1-10.**
- Snap a clip [12] onto screw behind collar to hold collar in place. **Fig. 1-11.**
- Slide middle rail against first rail.
- Place rail clamp [7] on each side of joint where rails meet. Match up holes in clamps with holes in rail. (Edge with lip is bottom of clamp.)
- Secure rail clamps with 4 bolts [8] and 4 nuts [9], hand tight only. **Fig. 1-12.**

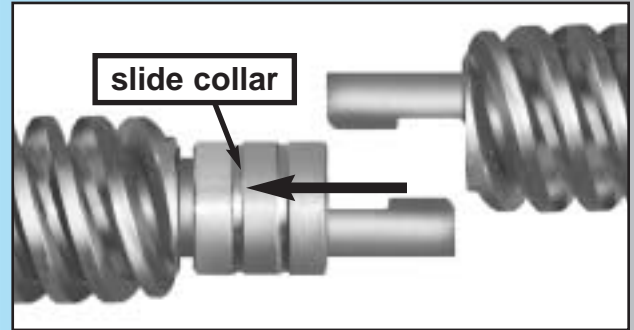
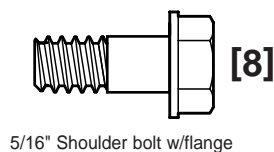

Fig. 1-8



Fig. 1-9

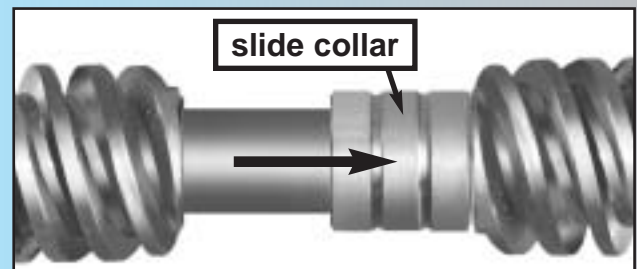

Fig. 1-10

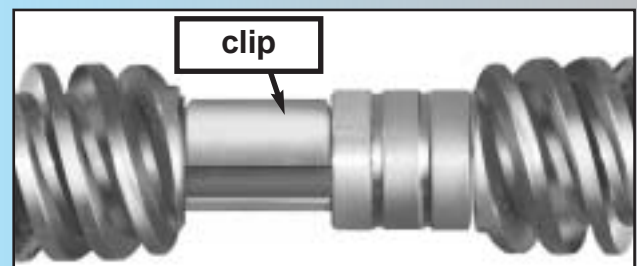

Fig. 1-11

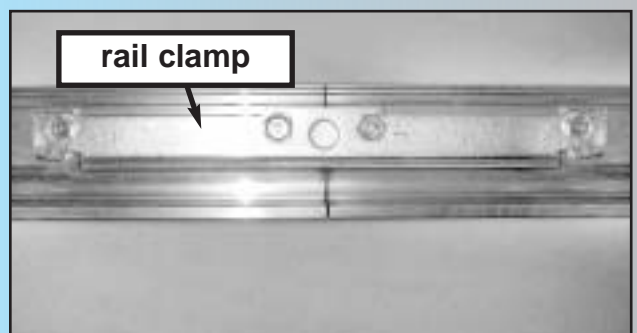

Fig. 1-12

NOTE: If installing an extension kit for an 8 feet high door, refer to the instructions included with the extension kit now.

7. **Attach “end” rail section [3C].**
 - Attach “end” rail in same way as “middle” rail (step 5). (“End” rail section screw has “hook” on one end only.)
8. **Flip power head/rail assembly over** (upside down), so that entire length of screw is visible from above.
9. **Install carriage stop [6].**
 - With bent tabs facing up, slide carriage stop into rail. **Fig. 1-13.**
 - Slide carriage stop along rail until it rests against power head.
10. **Install carriage [10].**
 - Place emergency release lever in released position. **Fig. 1-14.**
 - Make sure arrow on side of carriage (**Fig. 1-14**) is pointing away from power head. (Emergency release lever will be facing power head.)
 - Slide carriage into rail. **Fig. 1-15.**

NOTE: Carriage can be used as a temporary support for the rail while performing the next few steps of assembly. Slide carriage to mid point of rail. Place emergency release lever in engaged position.

11. **Flip assembly right side up.**
(Rail resting on carriage.)
12. **Attach rail strap [13].**
 - Place rail strap against end of rail so that attached stud passes in front of end of rail. **Fig. 1-16.**
 - Line up rail strap holes with rail holes.
 - Secure with 2 bolts [46] and 2 nuts [9].
13. **Make sure rail assembly is resting straight and level.**
 - FULLY TIGHTEN ALL BOLTS AND NUTS IN RAIL ASSEMBLY.



5/16" Flange nut

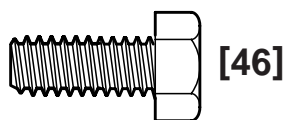

5/16" x 3/4" Hex head bolt

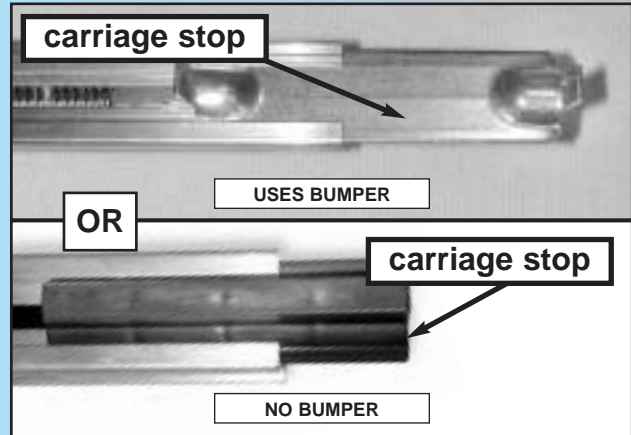

Fig. 1-13

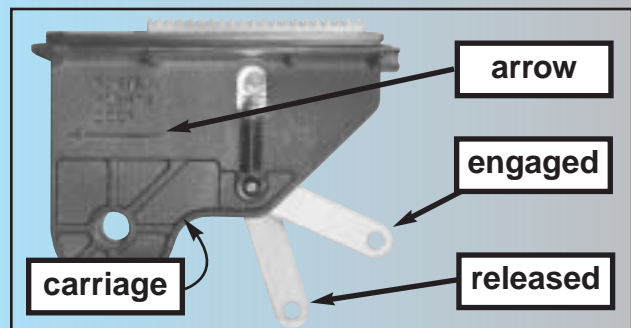

Fig. 1-14

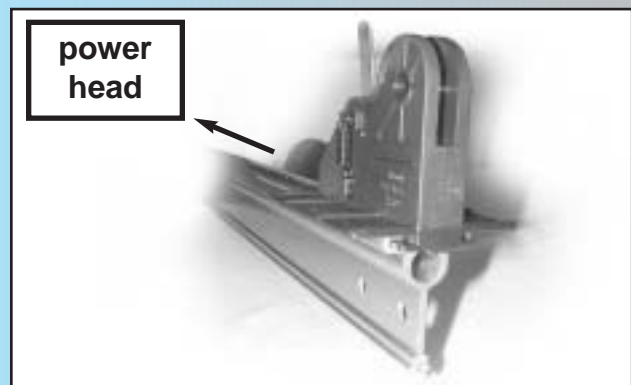

Fig. 1-15

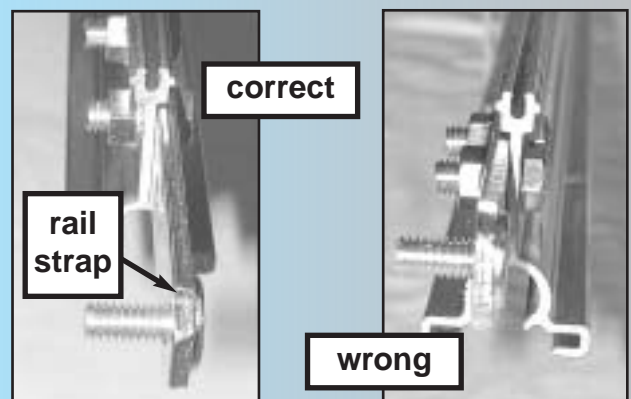

Fig. 1-16

14

OPEN GREEN PARTS BAG
Screws for attaching light cover are included in this bag.
Please set aside for use later.

14. Attach emergency release knob, cord and tag.

- Tie an overhand knot in one end of emergency release cord [17].
 - Slide cord through center of knob [18]. **Fig. 1-17.**
 - Slide cord through hole in emergency release lever (on carriage).
 - Tie a second knot in this end. **Fig. 1-18.**
 - Slip wire of emergency release tag [19] through hole in emergency release lever and twist it around itself.

15. Attach limit switches.

- “CLOSE” limit switch [15B].
(Switches are identical.)
 - Place “CLOSE” limit switch over top of rail about 12 inches from rail strap. **Fig. 1-19.**
 - *Check that white lever is toward power head.*
 - Insert set screw [16] into limit switch hand tight only to temporarily hold switch in place. **Fig. 1-19A.**
- Attach brown wire to switch. **Fig. 1-19B.**
 - Leaving some slack in wire (**Fig. 1-20**), run wire down inside groove in top of rail back to power head.
 - Use wire clip [44] to help maintain slack. **Fig. 1-20.**
- “OPEN” limit switch [15A].
 - Place “OPEN” limit switch over top of rail about 12 inches from power head. **Fig. 1-21.**
 - *Check that white lever is on side away from power head. (This means limit switches hang off opposite sides of rail. Check this to help verify they are installed properly.)*
 - Insert set screw [16] into limit switch hand tight only to temporarily hold switch in place.
 - Attach grey wire to switch. **Fig. 1-21.**
 - Leaving some slack in wire (**Fig. 1-21**), run wire down inside groove in top of rail back to power head.
 - Use wire clip [44] to help maintain slack. **Fig. 1-21.**
- Coil excess wire and tape it to top of power head. **Fig. 1-21A.**

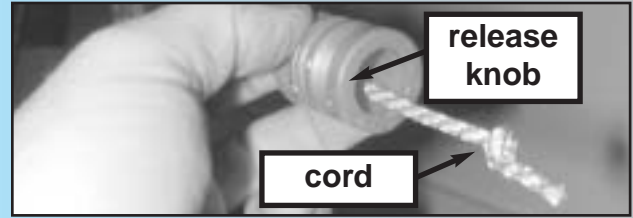

Fig. 1-17

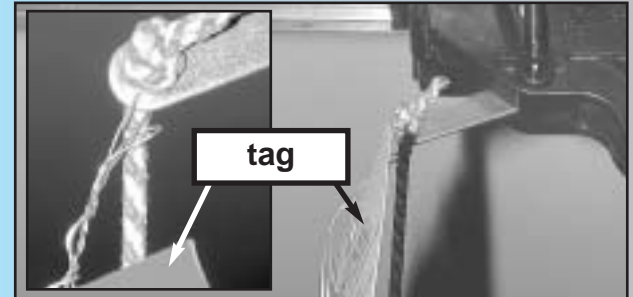

Fig. 1-18

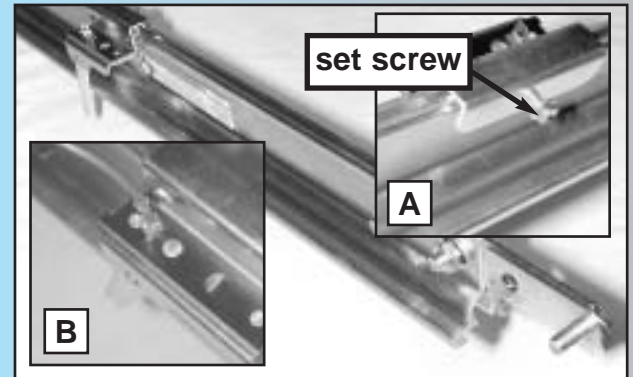

Fig. 1-19

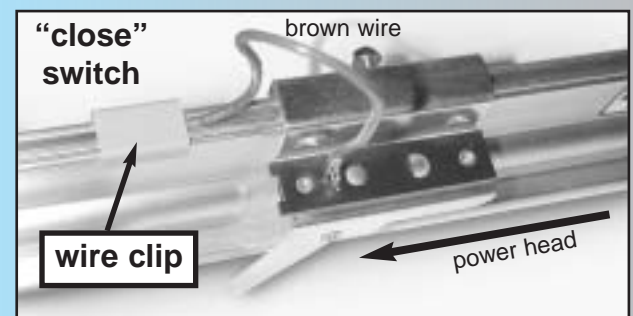

Fig. 1-20

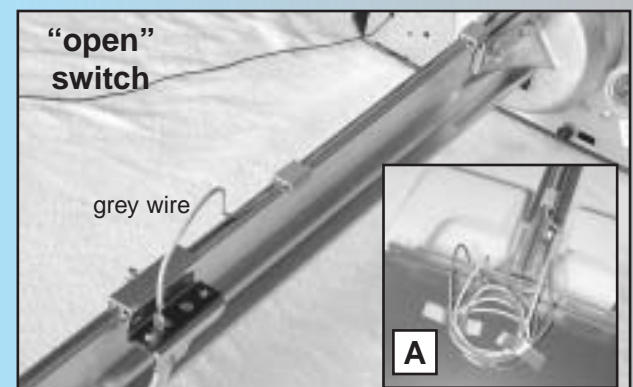

Fig. 1-21



#8-32 x 3/8" Hex head screw



Wire clip

NOTE: There are differences in installations depending on which type of door you have. These differences are explained throughout this section. Please note those steps which are applicable to your particular door.

REFER TO PAGES 2 & 3.

There are two basic types of residential garage doors. They are:

SECTIONAL DOORS—divided into a set of narrow panels (usually four) connected by hinges, so door can “bend” as it rides on a curved track.

1-PIECE DOORS—consist of one large panel and swivel on large spring-loaded hinges on each side of door.

1. Determining header bracket location.

- Find center of door from side to side.
 - Measure overall width of door.
(example: 16 feet)
 - Divide overall width by 2.
(example: $16 \div 2 = 8$ feet)
- Measure this distance from side of door and draw a pencil line vertically from the top of the door down approximately 1 foot. This is the centerline. **Fig. 2-1.**
 - Continue marking centerline on wall above door from top of door up approximately 1 foot. **Fig. 2-1.**

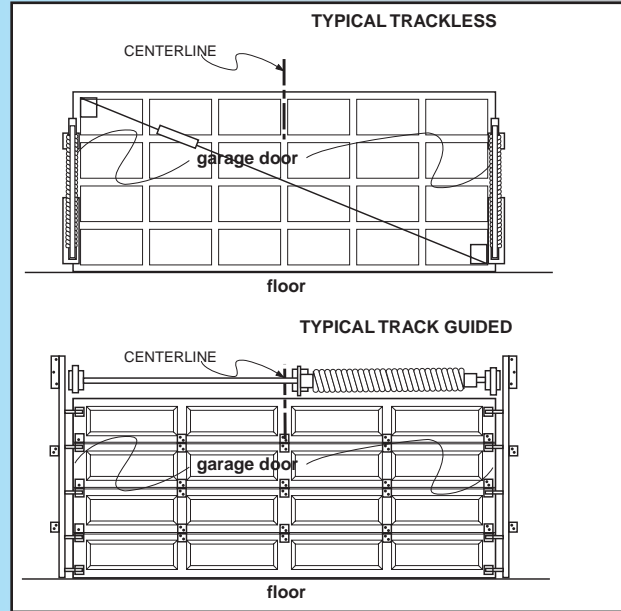

Fig. 2-1

Sectional doors may have one torsion spring (as shown) or two springs (one on each side).

Some older doors may have extension springs.

2. Finding highest point of travel.

- While raising garage door manually, watch top edge of door to see where it reaches its highest point. This is called “highest point of travel.” **Fig. 2-2.**
- A locking pliers can be used to hold the door in position by clamping it onto the rail. (A stool, chair, table or any object that can safely support door will also work.)
 - With door held partly open (at its “highest point”), measure distance from top edge to the floor.
- Remove support and gently lower door.
- Mark “highest point of travel” at centerline on wall above door. **Fig. 2-3.**

NOTE: Following step depends on type of door.

3. Final header bracket mounting location.

- For SECTIONAL DOORS—
add 2-1/2 inches to “highest point of travel” and mark this height on centerline. **Fig. 2-3.**
- For ONE-PIECE DOORS—
add 6 inches to “highest point of travel” and mark this height on centerline. **Fig. 2-4.**

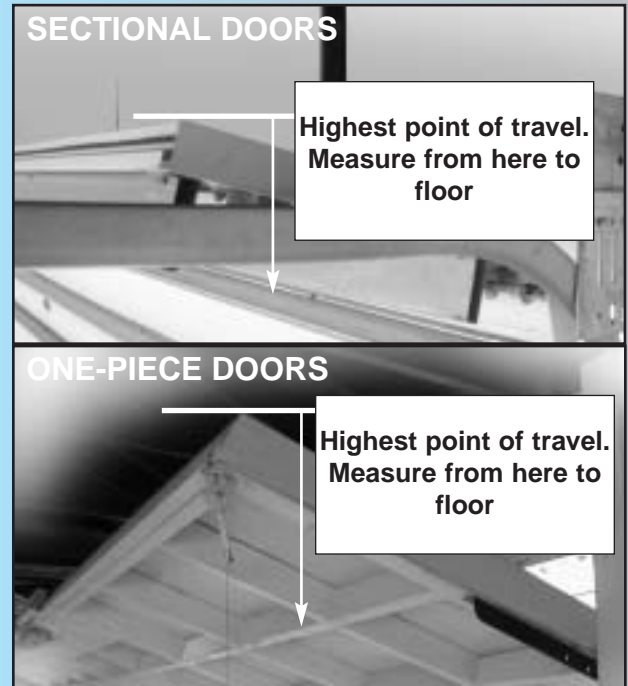

Fig. 2-2

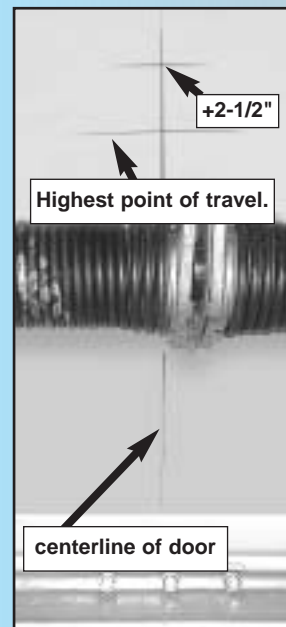

Fig. 2-3

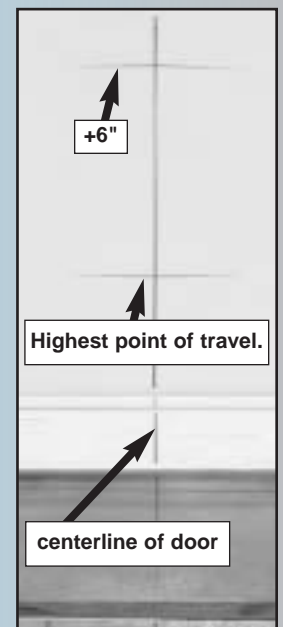

Fig. 2-4

NOTE: If torsion spring interferes with your final location, mark bracket location 2-1/2" or 6" above torsion spring depending on garage door type.

4. Check mounting location for strength. Header bracket must be attached to framework of garage. Fig. 2-5.

- If final header bracket position is on garage door header, continue with step 5.
 - If final header bracket position is above garage door header, a mounting plate must be installed and mounting location must be remarked before continuing with step 5.
- Fig. 2-5.**
- If your garage wall is finished (covered with drywall), continue with step 5.

OPEN ORANGE PARTS BAG

5. Mounting preparation.

- Hold bracket against wall where final header bracket height crosses centerline.
- Make sure flange where rail strap attaches, is on centerline. **Fig. 2-6.**
- Mark screw hole locations.
 - If your wall is finished, take a small “finish nail” and gently tap it through drywall where you have marked screw holes to find out if there is wood behind mounting location. If your marked location is solid, continue with step 6.
 - If your marked mounting location is not solid, a mounting plate must be installed and mounting location remarked before continuing. **Fig. 2-7 and Fig. 2-5.**

6. Mount header bracket [20].

- Drill 5/32 inch pilot holes at marked screw hole locations.
- Fasten header bracket using 3 lag screws [22].

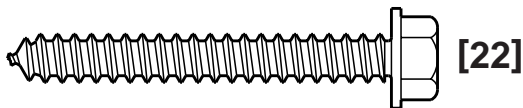

1/4" x 2" Lag screw

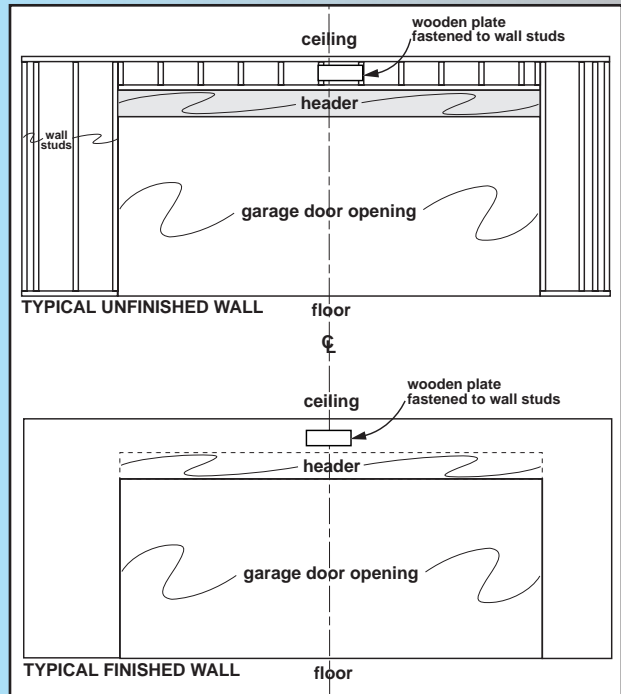

Fig. 2-5

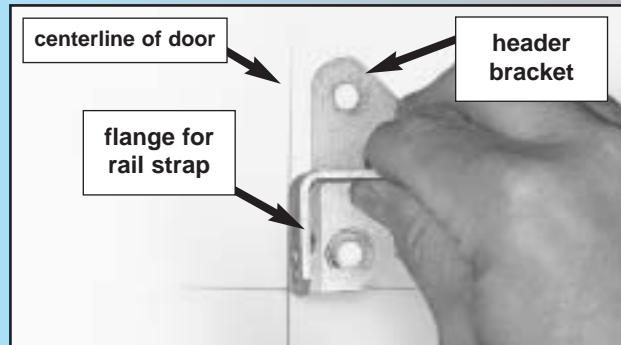

Fig. 2-6

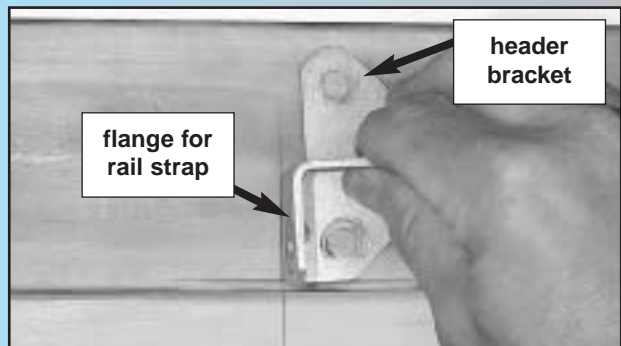

Fig. 2-7

7. Attaching rail to header bracket.

- Gently set power head on garage floor while leaning rail strap against header bracket. (It is recommended that you place a piece of cardboard or similar material between power head and floor to prevent scrapes and scratches to power head.)

NOTE: It may be necessary to support power head above floor. As little as a few inches, or as much as 5 or 6 feet depending on position of torsion spring(s). Be sure to use a stable support device, such as a ladder.

- Slide threaded stud of rail strap through hole in flange of header bracket.
- Fasten with nut [9], finger tight only. **Fig. 2-8.**



Fig. 2-8



5/16" Flange nut

8. Mounting power head.

- Raise power head and support it high enough that you can manually raise garage door fully open.
- Line up power head and rail with center of door. **Fig. 2-9.**
- Keeping power head centered, mount to ceiling:
 - at proper height;
 - a. for sectional doors rail should be level with floor or slightly below level. **Fig. 2-10.**
 - b. for 1-piece doors rail should clear door by about 2 inches. **Fig. 2-10.**



Fig. 2-9

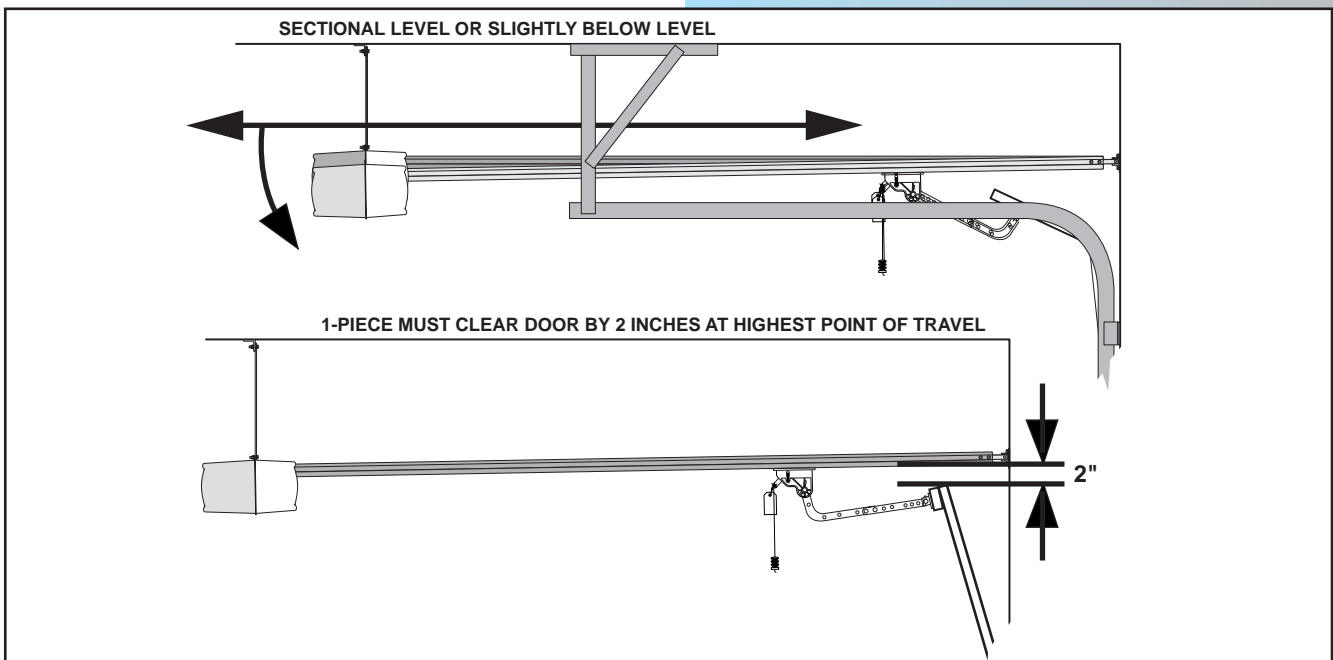

Fig. 2-10

- using one of the preferred methods shown, **Fig. 2-11**, mount power head. (It is possible to use other mounting methods. The critical point to remember is that the mounting assembly must be solidly attached and able to support the weight of the power head.) **DO NOT ATTACH TO DRY WALL OR SUSPENDED CEILING.** It must be anchored to the framework of the garage.

- Fully tighten rail strap nut.

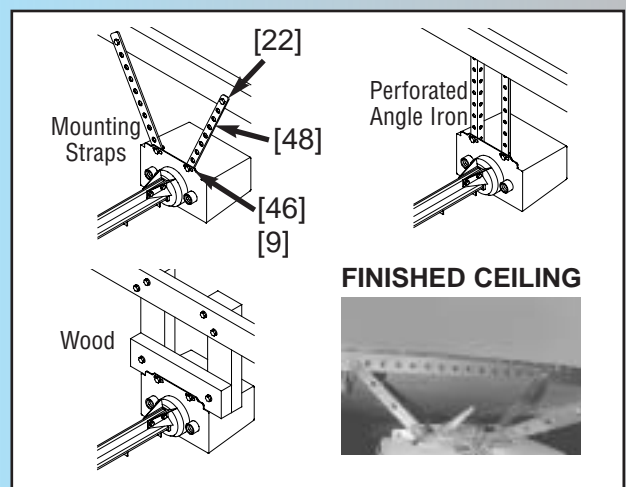

Fig. 2-11

9. Mounting door bracket [21].

- Center of bracket must be on centerline of door and must be mounted as high as possible. **Fig. 2-12A & B.**
- Hold bracket against door at preferred location and mark screw holes.
 - for **wooden doors**, drill 5/32 inch pilot holes.
 - a. Fasten door bracket using 3 lag screws [22].
 - b. Check thickness of door against lag screws. (It may be necessary to mount door bracket on a 2" x 6", etc. attached to inside of door to prevent screws from coming out other side of garage door. **Fig. 2-12A.**

- for light-weight doors

CAUTION: In the case of sectional doors, the door bracket must not be below the highest set of rollers. **Fig. 2-13.**

- there are a wide variety of reinforcements depending on manufacturer and some are equipped with hardware that is intended to be used in place of the door bracket.

Be sure to confirm proper use of this hardware with your door manufacturer. Unauthorized improper use of these attachment systems could void your warranty. WHEREVER POSSIBLE—USE DOOR BRACKET SUPPLIED WITH YOUR GENIE OPERATOR.

- a. Fasten door bracket using 3 self-drilling screws [47].

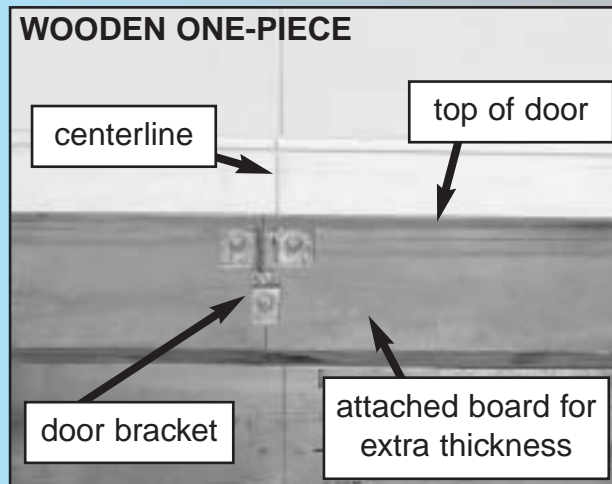

Fig. 2-12A

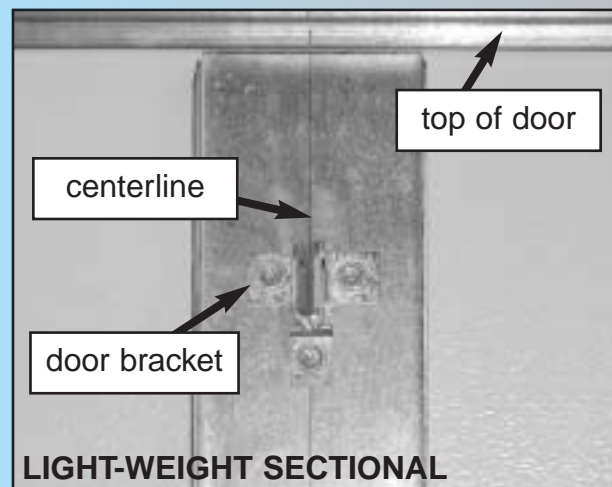

Fig. 2-12B

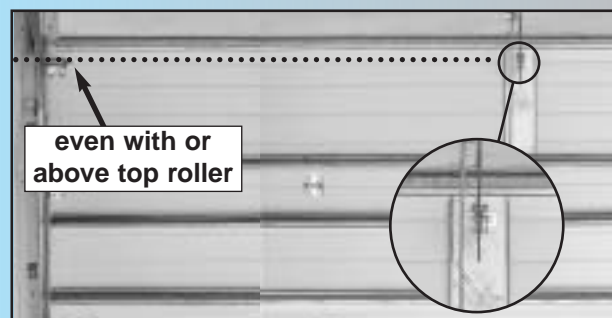
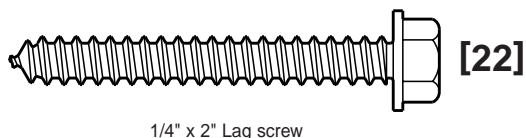
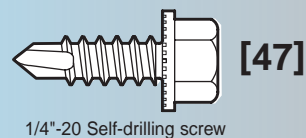

Fig. 2-13



1/4" x 2" Lag screw



1/4"-20 Self-drilling screw

OPEN YELLOW PARTS BAG

10. Attach door arms [23] and [26].

- **For sectional doors.**
 - Connect short leg of curved arm to door bracket. **Fig. 2-14.**
 - Use clevis pin [24] and cotter pin [25]. **Fig. 2-14.**
 - Connect straight arm to carriage.
 - Use clevis pin [24] and cotter pin [25].
 - Overall length of arms together should be **as short as possible**, but must not be so short that they are vertical when the door is fully closed. **Fig. 2-14.**
 - a. Move carriage as necessary to adjust length.
 - b. Place bolts [27] and nuts [28] as far apart as possible. **Fig. 2-14.**
 - c. Tighten bolts and nuts.
- **For 1-piece doors.**
 - Connect short leg of curved arm to carriage. **Fig. 2-14.**
 - Use clevis pin [24] and cotter pin [25]. **Fig. 2-14.**
 - Connect straight arm to door bracket.
 - Use clevis pin [24] and cotter pin [25].
 - Overall length of arms together should be **as long as possible**. **Fig. 2-14.**
 - a. Move carriage as necessary to adjust length.
 - b. Place bolts [27] and nuts [28] as close together as possible. **Fig. 2-14.**
 - c. Tighten bolts and nuts.

11. Adjust emergency release knob height.

- Knob should hang approximately 6 feet from the floor.
 - adjust as necessary to clear vehicles yet maintain height where it can be easily reached.
- Pull cord through lever until knob is at desired height.
- Tie a new knot at the lever.
- Cut off excess cord.

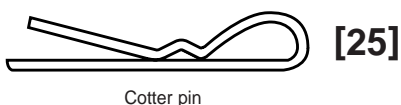
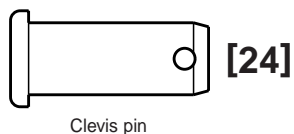

SECTIONAL DOOR

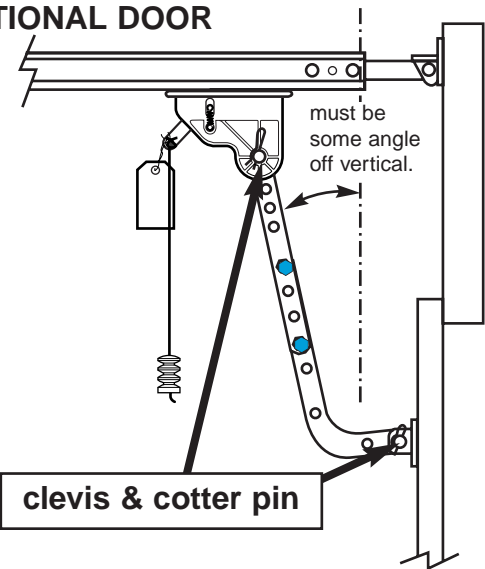

●—bolts/nuts (far apart as possible)

1-PIECE DOOR

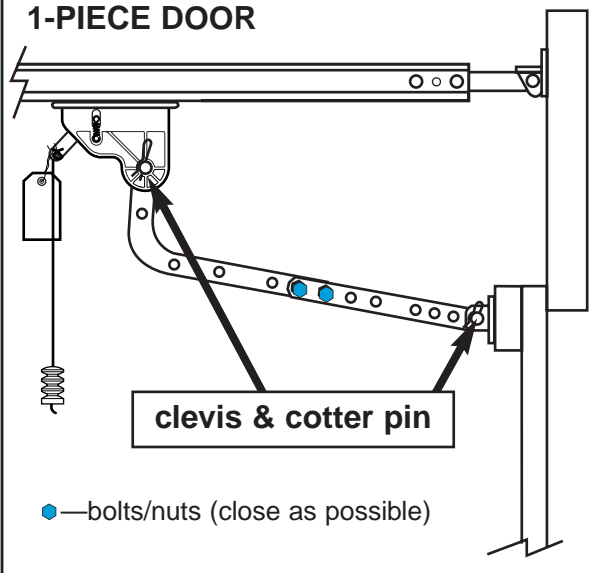

●—bolts/nuts (close as possible)

Fig. 2-14

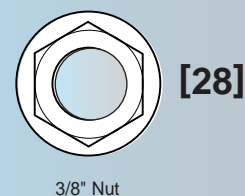
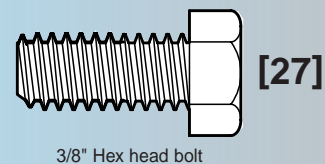

⚠ WARNING

There should be no electrical power to the operator while installing Safe-T-Beam System® wires. If you have plugged in the power cord—UNPLUG IT NOW.

NOTE: Operator will not close door automatically unless the Safe-T-Beam® System is installed.

1. Mounting brackets.

- Mark both sides of garage door frame or wall 5" above floor. **Fig. 3-1.**
- Hold bracket [38] against door frame or wall.
 - Check if brackets extend out from wall far enough, so tongue of bracket is beyond door, tracks or any door hardware.
 - If not:
 - a. STB bracket extensions are available at local dealer.
 - b. Blocks of wood, etc. may be substituted for extensions.
- Center bracket on your mark **Fig. 3-2.**
- Fasten each with 2 screws [40]. **Fig. 3-2.** (Tongues should point toward each other.)

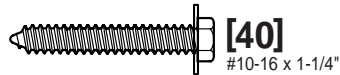

NOTE: Mounting brackets can be attached to brick walls or concrete floor using masonry anchors (not provided).

2. Mounting STB source and sensor.

- If garage has only one garage door.
 - Determine which side of garage receives most direct sunlight **Fig. 3-4**, and place Red LED here whenever possible **Fig. 3-4.**
- For multiple doors.
 - Preventing crossed signals is critical.
 - Place source and sensor modules on adjacent doors facing in opposite directions **Fig. 3-4.**

NOTE: To help prevent interference from sun, STB sensors (Green LED) may be placed further from the door opening where they will spend more time in shadows.

- Slide source/sensor onto tongue of bracket until it clicks into place **Fig. 3-3.**

OPEN RED PARTS BAG

3. Wiring.

- Route wire [29] using either method shown **Fig. 3-5.**
- Securely fasten wires to ceiling and walls as you go using insulated staples [30].
 - Staples should be snug only. Staples which are too tight can cut wires.

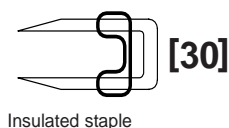

Fig. 3-1

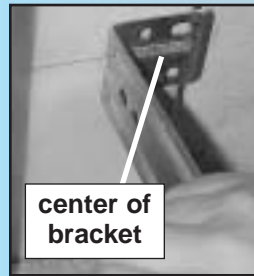

Fig. 3-2

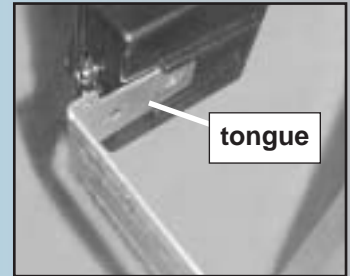

Fig. 3-3

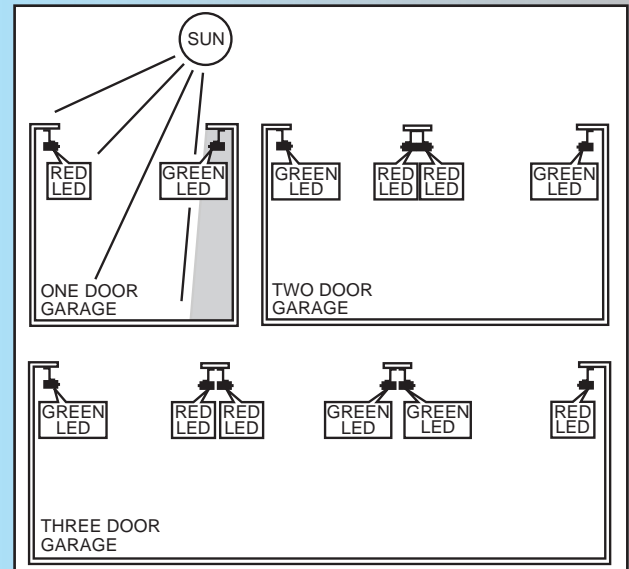

Fig. 3-4

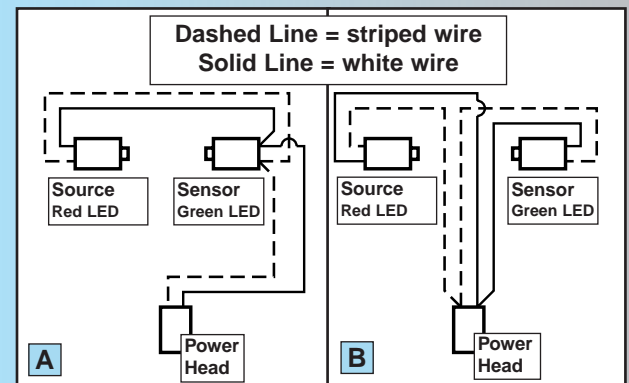

Fig. 3-5

⚠ CAUTION

Staples which are too tight can cut or pinch wires. Cut or pinched wires can cause the STB System to stop working. When using the insulated staples, make sure you fasten them only as tightly as needed to hold the wire snugly.

- Make wire attachments at STBs.
 - Split and strip wire ends to be connected as shown **Fig. 3-6**.
 - Loosen terminal screws.
 - Insert wire under flat plate and tighten screw. It does not matter which wire, white or striped, goes on which terminal **Fig. 3-7**.
 - Make wire attachments at power head.
 - STBs are connected to terminals #3 and #4 on power head **Fig. 3-8**. It does not matter which wire, white or striped, goes on which terminal.
- 4. Check the following.**
- Ensure that no part of door or its hardware is in path between lenses of **source** and **sensor**.
 - Ensure that tops of lenses are between 5"-6" above the floor **Fig. 3-9**. The brackets are flexible, and can be adjusted slightly if needed.

NOTE: Safe-T-Beam® alignment check will be performed following connection to electrical power (see page 26). DO NOT PLUG IN YET!

(See Illustration on page 3 for a full view of Safe-T-Beam® location.)

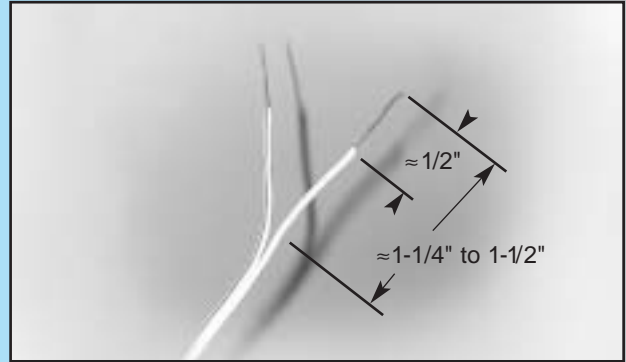

Fig. 3-6



Fig. 3-7



Fig. 3-8

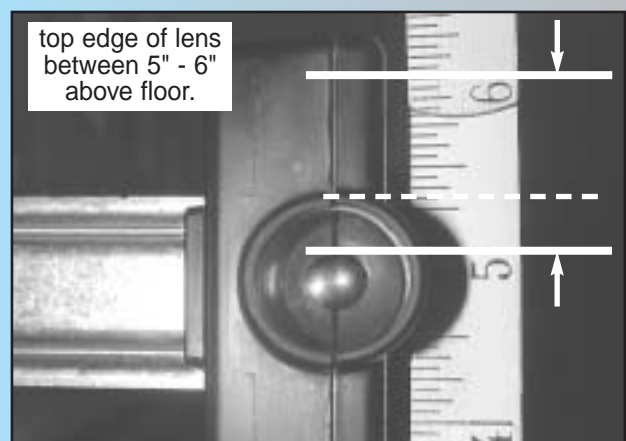

Fig. 3-9

⚠ WARNING

Power must be removed before attaching wires. Be sure ends do not touch each other or other terminals.

⚠ CAUTION

- Use of any other wall control can cause the door to operate unexpectedly and the light not to work.
- Cut or pinched wires can cause door operator to malfunction. Drive staples just tight enough to hold wire.

1. Run wire from power head to wall control

- Find location for wall control:
 - In sight of door and away from moving parts.
 - At least 5 feet from floor, so small children cannot reach it.
- Route wire from wall control to power head.
- Use staples to fasten wire to ceiling and wall.

NOTE: Use only staples included

2. Split wires at ends and remove 1/2 inch of insulation from end of each Wire. Fig. 4-1.

3. Attach wires to terminals. Fig. 4-2, Fig. 4-3.

- Loosen (Do Not Remove) screws from Terminals at power head and wall control
- Connect wires to power head
 - White wire to terminal #1
 - Striped wire to terminal #2
 - Tighten screws
- Connect wires to wall control
 - Striped wire to terminal "B"
 - White wire to terminal "W"
 - Tighten screws

4. Mount wall control. Fig. 4-4.

- For Wall Console or Wall Button.
 - Use pan head screws [34].

5. Mount entrapment warning label. Fig. 4-4.

- Remove protective backing.
- Stick label to wall next to wall control.
 - Tacks or staples may be required on some rough texture surfaces.

NOTE: Additional wall controls are available from your dealer. ONLY ONE OF YOUR WALL CONTROLS MAY BE THE LIGHTED TYPE. If you have a lighted wall control, all your additional controls must be un-lighted. More than one lighted wall control per operator will cause a malfunction.

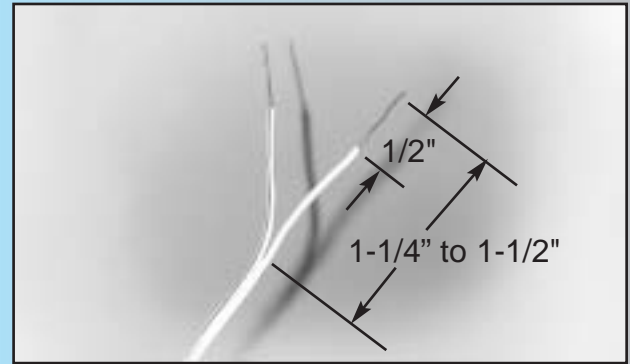

Fig. 4-1

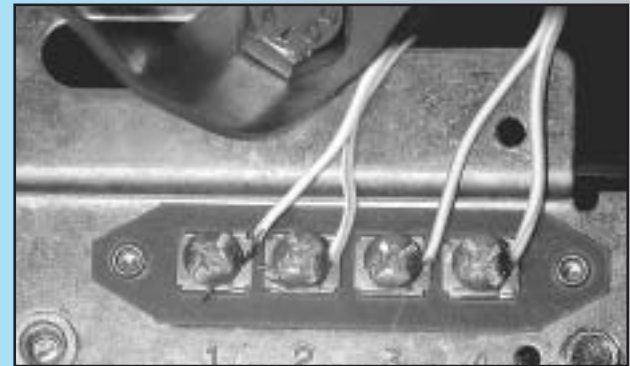

Fig. 4-2

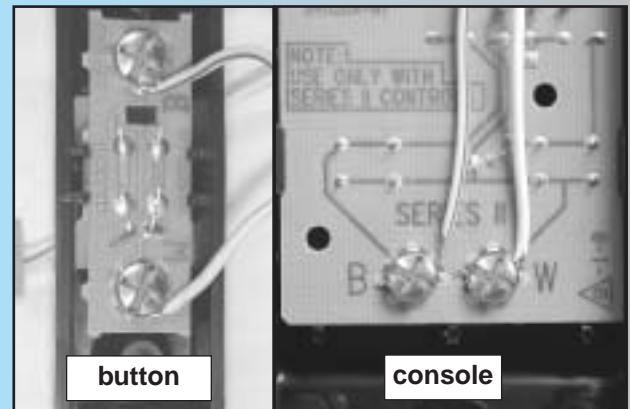
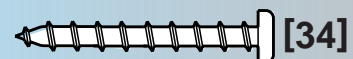

Fig. 4-3



Fig. 4-4



#6 x 1-1/4" Pan head screw

1. Wall console. Fig. 4-5.

A. Vacation locking switch.

- Lock disable all controls after door closes..
- Unlock allows all controls to work normally.

NOTE: Carriage must stay in contact with "CLOSE" limit switch in order for the vacation locking switch to work.

B. Door control button.

- Opens and closes door from inside garage.
- Lights on shows system has power available and vacation switch is not locked.
- Lights out shows either power is not available or vacation locking switch is locked.

C. Independent light control.

- Turns operator lights on and off without moving door.

2. Wall Button

- Operates door from inside garage.

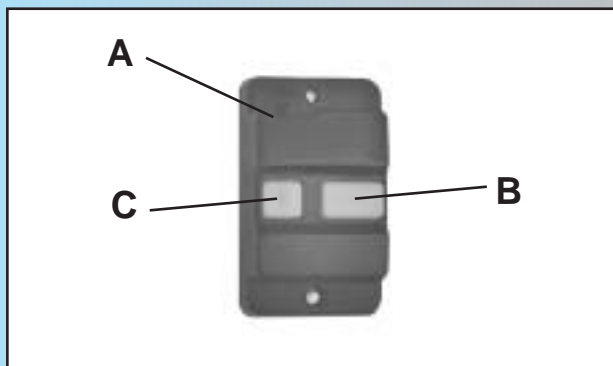

Fig. 4-5

SECT 5—LIGHT & LENS INSTALLATION

1. Install light bulbs.

- 2 bulbs.
 - No more than 60 watts each.
 - **Do Not** use short neck bulbs.
 - Whenever possible, use bulbs rated for:
 - Rough service
 - Vibration
 - Appliances

2. Install lens.

- Hook bottom hinges into slots at bottom of front plate. **Fig. 5-1.**
- Swing lens up over lights. Check for alignment between the screw holes in the Lens and those on the metal front plate.
- Lens will be fastened with 2 pan head screws. ([42] green parts bag). **Fig. 5-2.** DO NOT FASTEN YET! Wait until you have completed programming the Remote Controls.

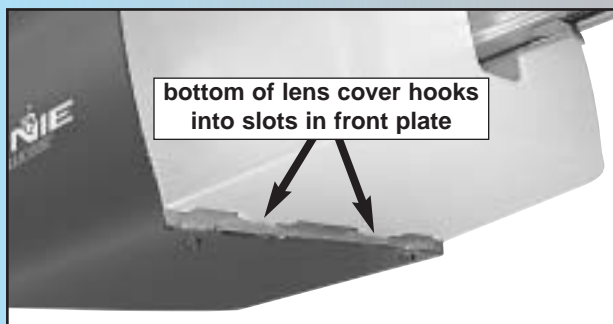

Fig. 5-1



Fig. 5-2



#8 x 3/8" Pan head screw

WITH GROUNDED PLUG:

26

⚠ WARNING

To reduce the risk of electrical shock, this equipment has a grounded type plug that includes a third (grounding) pin. This plug will only fit a grounded type outlet. If you do not have a grounded outlet, contact a qualified electrician to install one. **DO NOT** alter the plug in any way. The door operator must be properly grounded in order to prevent personal injury and damage to the components.

1. Check local building codes.
 - Does building code require permanent wiring?
 - If not, skip to step 9.
 - *If yes, have an electrician perform steps 2 through 8.*

CONNECT POWER WITH PERMANENT WIRING

Instructions for electrician.

2. Remove power from circuit.
 3. Remove motor cover (Fig. 6-1).
 - Remove 4 screws [41] from cover and slide off back of power head.
 4. Remove and discard power cord.
 - Cut off power cord inside power head.
- NOTE: There must be at least 6 inches of black and white wire inside the power head (Between splice and entrance bushing).**
- Remove and throw away power cord, strain relief and knock-out.
5. Install suitable entrance bushing.
 6. Connect permanent wiring to power head wires.
 - Connect white supply line to white wire.
 - Connect black supply line to black wire.
 - Connect ground to green wire (ground).

NOTE: Use only U.L. recognized wire nuts

7. Replace motor cover.
 - Slide motor cover back on.
 - Replace and tighten 4 screws.
8. Reconnect power to circuit.

CONNECT POWER WITH PLUG

9. Plug in door operator.
 - See warning above.
 - Plug door operator into a grounded outlet.
 - Perform STB® alignment check (Fig. 6-2).

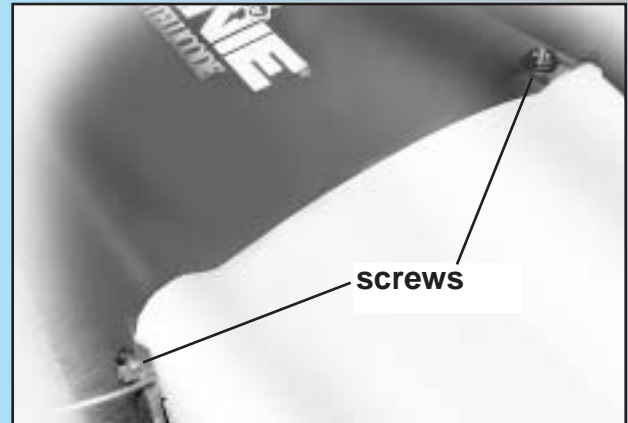

Fig. 6-1

Safe-T-Beam® Alignment Check

After turning the electrical power on, if the STBs are not in proper alignment, the red LED (Source) will blink continuously.

To correct the problem – the brackets are flexible and can be adjusted slightly to bring the system into alignment.

When the STBs are in alignment the red LED will stop blinking and stay on.

Fig. 6-2

⚠ CAUTION

Door opens rapidly

- Keep clear of door and its path.
- Keep ladder to side of power head to prevent being hit by moving parts.

Be sure and set force adjustments at minimum required to operate door.

1. Set limit switch position.

- Check door fully closed.
 - If not, close door manually.
- Check carriage is between limit switches.
 - If not, move “CLOSE” limit switch (brown wire) to new position between door and carriage.
 - Slide “CLOSE” limit switch back toward carriage until lever is fully lifted. **Fig. 7-1.**
 - Tighten limit switch set screw.
- Manually open door to fully open position..
- Check carriage is between limit switches.
 - If not, move “OPEN” limit switch to new position between power head and carriage.
 - Slide “OPEN” limit switch back toward carriage until lever is fully lifted. **Fig. 7-1.**
 - Tighten limit switch set screw.

2. Adjust opening force.

- Engage Carriage by pulling Emergency Release Lever toward Powerhead until Lever snaps into engaged position.
- On front panel of power head—find adjusting screw marked “CLOSE.” **Fig. 7-2.**
- Turn screw gently counterclockwise until it stops.

NOTE: Little force required to move adjusting screws.

- Run operator using wall control.
- Observe door runs to “CLOSE” limit switch.
 - If not, increase closing force by turning “CLOSE” adjusting screw clockwise slightly (about 1/16 turn).
- Repeat until door runs to “CLOSE” limit switch.
- Check door is fully closed.
 - If not, move “CLOSE” limit switch toward door as necessary to achieve fully closed.

3. Adjust closing force.

- On front panel of power head—find adjusting screw marked “OPEN.” **Fig. 7-2.**
- Turn screw gently counterclockwise until it stops.
- Run operator using wall control.
- Observe door runs to “OPEN” limit switch.
 - If not, increase opening force by turning “OPEN” adjusting screw clockwise slightly (about 1/16 turn).
- Repeat until door runs to “OPEN” limit switch.
- Check door is fully open.
 - If not, move “OPEN” limit switch toward power head as necessary to achieve fully open.

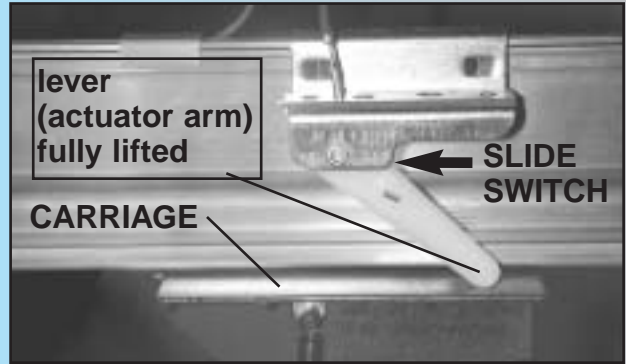

Fig. 7-1

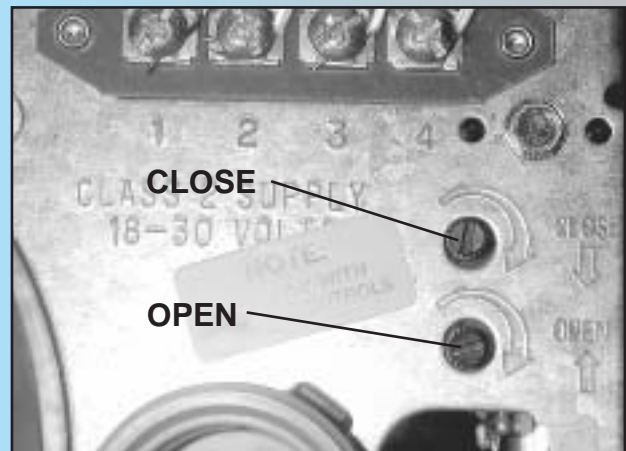

Fig. 7-2

NOTE:

When the garage door is closing and contacts a vehicle or other obstruction, the contact reverse mechanism may not prevent damage to the obstruction, garage door or garage door operator.

Limit switch adjustments must be completed before running contact reverse test.

1. Test contact reverse.

- Open door using wall control.
- Lay 2" x 4" board* on floor in center of garage door opening. **Fig. 7-3.**
- Close door using wall control.
 - Door should stop and reverse within 2 seconds of contacting the board.
 - If door does not reverse properly:
 - a. Decrease closing force a small amount by turning the "CLOSE" force adjustment screw slightly counterclockwise.
 - b. Test contact reverse again.
 - c. Repeat steps a. and b. until contact reverse works properly.

*If you don't have a 2" x 4" board handy, any object 1-1/2 inches high that can withstand being hit by the garage door without sustaining damage is fine.

NOTE: If door is stopping but not reversing, "CLOSE" limit switch must be moved closer to door.



Fig. 7-3

SECT 8—BATTERY & VISOR CLIP

1. Install/replace battery Fig. 8-1.

- Using a pen or similar object, gently push in on tab.
- Cover snaps open. Remove old battery.
- Observe polarity markings (+,-) inside battery compartment.
- Match new battery to polarity markings and instal new **EVEREADY** A23, 12 Volt battery.
- Replace battery cover.

NOTE: Use only EVEREADY A23, 12 Volt battery.

2. Attach visor clip Fig. 6-1.

- Slide clip in slot on back of remote control.
 - Snap in place.

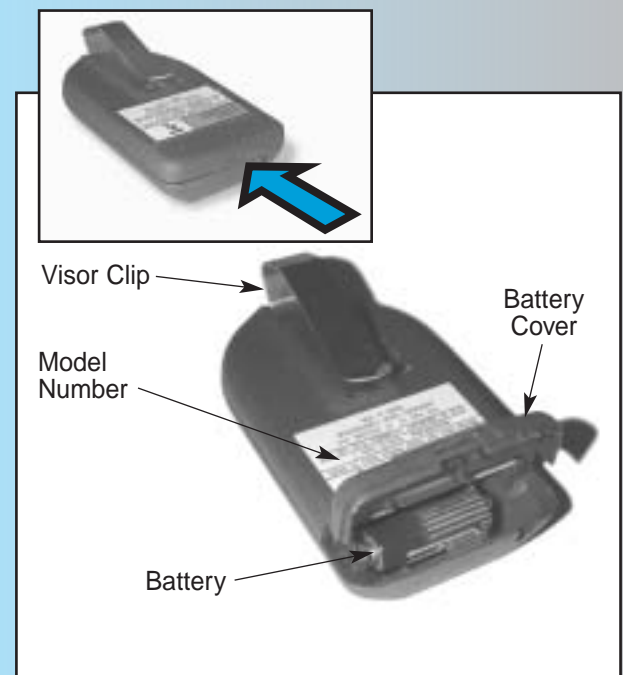

Fig. 8-1

PROGRAMMING REMOTE CONTROLS

NOTE: Each remote device must be programmed separately

⚠ WARNING

Moving door can cause serious injury or death.

- Keep people clear of opening while door is moving.
- Do not allow children to play with remote controls.

If Safety reverse does not work properly:

- Close door and disconnect operator using emergency release.
- Do not use door operator, remote controls, or wireless keypad.
- Refer to door and door operator owner’s manuals before attempting any repairs.

NOTE: Remote controls will not close door if Safe-T-Beam® malfunctions.

NOTE: When programming remote control, it must be at least 24 inches from the antenna.

1. Program one button remote.

- Lower lens cover.
- Locate learn code button and learn indicator on power head **Fig. 9-1**.
- Press and release learn code button.
 - Red learn indicator blinks 2 times per second.
- Press remote control button once within 30 seconds.
 - Red learn indicator stays lit.
- Press remote control button again.
 - Red indicator goes out and memory is stored.

NOTE: If red indicator blinks approximately 4 times per second, programming has stopped. If programming stops, repeat above steps.

2. Program multi-button remote.

- Repeat step 1 above “Program one-button remote” for each button and operator.

NOTE: Each button on a multi-button remote control is for a different operator. You cannot use more than one button on a multi-button remote for a single door.

3. Operating remote.

- Press button once:
 - If door is at up or down limit, door will move away from that limit.
 - If door is stopped between limits, it will move toward the limit where it was last stopped.
 - If door is moving, it will stop.

NOTE: Door automatically stops at end of open or close cycle.

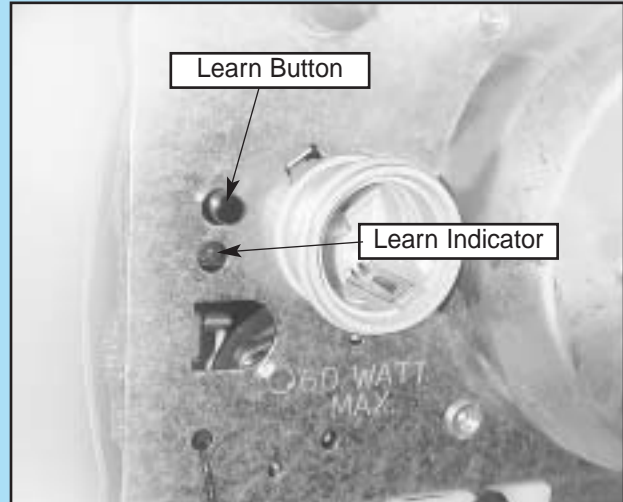

Fig. 9-1

To erase all receiver memory, such as following loss of remote, home sale or tenant turn-over.

- Press and hold learn code button for 10 seconds or until learn code indicator goes out—memory is erased.
- Program remotes as before.

FCC and IC CERTIFIED

This device complies with FCC Part 15 and RSS 210 of Industry Canada. This equipment has been tested and found to comply with the limits for a Class B digital device, pursuant to Part 15 of the FCC Rules. These limits are designed to provide reasonable protection against harmful interference in a residential installation. This equipment generates, uses and can radiate radio frequency energy and, if not installed and used in accordance with the instructions, may cause harmful interference to radio communications. However, there is no guarantee that interference will not occur in a particular installation. If this equipment does cause harmful interference to radio or television reception, which can be determined by turning the equipment off and on, the user is encouraged to try to correct the interference by one or more of the following measures:

- Re-orient or relocate the receiver antenna.
- Increase the separation between the operator and receiver.
- Connect the operator into an outlet on a circuit different from that to which the appliance is connected.
- Consult the dealer.

TRANSMITTER COMPLIANCE STATEMENT

Transmitters comply with all United States and Canadian legal requirements as of the date of manufacture. No warranty is made that they comply with all legal requirements of any other jurisdiction. If transmitters are to be used in another country, the importer must determine compliance with any local laws and regulations which may differ from United States and Canadian requirements prior to use.

Los transmisores cumplen con todas las reglamentaciones legales de los Estados Unidos y del Canadá, en la fecha de fabricación. Ninguna garantía se da que cumplan con todas las reglamentaciones legales de ninguna otra jurisdicción. Si los transmisores se van a utilizar en otro país, el importador debe determinar si cumplen con las reglamentaciones y leyes locales que puedan ser diferentes a las reglamentaciones de los Estados Unidos y del Canadá, antes de usar los mismos.

Les metteurs sont conformes à la réglementation américaine et canadienne comptant de leur date de fabrication. Aucune garantie n'est stipulée indiquant qu'ils sont conformes à toutes les prescriptions juridiques d'autres autorités. Si les metteurs sont utilisés dans d'autres pays, il incombe à l'importateur d'en déterminer leur conformité aux lois et règlements locaux pouvant différer de celles des États-Unis et du Canada avant toute utilisation desdits metteurs.

Sendeger te entsprechen allen gesetzlichen Bestimmungen in den USA und Kanada zum Zeitpunkt der Herstellung. Wir übernehmen keine Gewährleistung für die Einhaltung aller gesetzlichen Bestimmungen in anderen Ländern. Sollen Sendeger te in anderen Ländern eingesetzt werden, so muss der Importeur vor dem Gebrauch sicherstellen, dass die Sendeger te auch solchen lokalen Bestimmungen entsprechen, welche von den Bestimmungen der USA und Kanadas abweichen.

截止于制造日期, 传动装置符合美国和加拿大的所有法律要求。不提供传动装置符合任何其他司法地区所有法律要求之担保。如果传动装置需在任何其他国家使用, 进口商必须在使用之前确定装置符合与美国和加拿大要求不同之所有地方法规条例。

トランスミッターは、製造日付けのアメリカ合衆国及びカナダの法的条件に準拠します。しかしながら、トランスミッターがアメリカ合衆国及びカナダ以外の国の法的条件に準拠するか否かは一切保証できません。トランスミッターがアメリカ合衆国及びカナダ以外の国で使用される場合、同製品の使用に先立つ法規制がこれらの国々と異なることがあるため、輸入者は同製品が輸入国の法規制に準拠することを確認しなければなりません。

트랜스미터들은 미국과 캐나다 전역에서 제조 날짜를 명기해야 하는 요구사항에 따라야 합니다. 기타 다른 관할권의 모든 법적인 요구 사항에 따라야 하는 책임은 없습니다. 만일 트랜스미터들이 기타 다른 지역에서 사용될 경우 수입업자는 사용하기에 앞서 미국과 캐나다와의 요구사항과는 다를지도 모르는 그 지역의 법과 조례에 따라야 할지의 여부를 결정해야 합니다.

IMPORTANT SAFETY INSTRUCTIONS

⚠ WARNING

To reduce the risk of severe injury or death:

- 1 READ AND FOLLOW ALL INSTRUCTIONS.
- 2 Never let children operate or play with the Door Controls. Keep the Remote Control away from children.
- 3 Always keep the moving door in sight and away from people and objects until the door is completely closed. **NO ONE SHOULD CROSS THE PATH OF THE MOVING DOOR.**
- 4 NEVER GO UNDER A STOPPED, PARTIALLY OPEN DOOR.
- 5 Test Opener monthly. The door **MUST** reverse on contact with a 1-1/2" high object (or a 2" x 4" board laid flat) at the center of the doorway on the floor. After adjusting either the Force or the Limit of travel, retest the Door Opener. Failure to adjust the Opener properly may cause severe injury or death.
- 6 When possible use the Emergency Release only when the door is closed. Use caution when using this Release with the door open. Weak or broken springs are capable of increasing the rate of door closure and increasing the risk of severe injury or death.
- 7 KEEP GARAGE DOORS PROPERLY BALANCED. See Owner's Manual. An improperly balanced door increases the risk of severe injury or death. Have a Genie Factory Authorized Dealer make repairs to cables, spring assemblies, and other hardware.
- 8 **SAVE THESE INSTRUCTIONS.**

SECT 10—MAINTENANCE & TROUBLESHOOTING

MONTHLY MAINTENANCE

Door springs and hardware.

- Oil door rollers, bearings, and hinges.
 - Use silicone lubricant or light oil.

NOTE: Do not operate door automatically or manually if springs are broken. CONTACT A PROFESSIONAL FOR SERVICE.

Balance door.

- Close door.
 - Pull emergency release knob down.
- Raise door manually about 3 feet.
 - Door should stay in that position.

NOTE: If door moves, HAVE DOOR SERVICED BY A PROFESSIONAL.

- Reattach carriage to rail assembly.
 - Pull emergency release knob toward power head.
- Close door

Contact reverse.

- Lay 2" x 4" board flat on the floor in the center of garage doorway (See page 28).
- Close door using wall button or remote control.

NOTE: If door fails to reverse on contact with board. See page 28, CONTACT REVERSE. If operator still fails, replace operator or HAVE THE OPERATOR SERVICED BY A PROFESSIONAL.

YEARLY MAINTENANCE

Drive Screw

- Lubricate drive screw.
 - Use GENIE GLU3 lubricant.

CAUTION

Use only GENIE GLU3 lubricant, because other lubricants may damage operator.

MAINTENANCE CHECK-OFF

YEAR

1	2	3	4	5	6	7	8	9	10	11	12	13	14	15	16	17	18	19	20
---	---	---	---	---	---	---	---	---	----	----	----	----	----	----	----	----	----	----	----

MONTH

J	J	J	J	J	J	J	J	J	J	J	J	J	J	J	J	J	J	J	J	J
F	F	F	F	F	F	F	F	F	F	F	F	F	F	F	F	F	F	F	F	F
M	M	M	M	M	M	M	M	M	M	M	M	M	M	M	M	M	M	M	M	M
A	A	A	A	A	A	A	A	A	A	A	A	A	A	A	A	A	A	A	A	A
M	M	M	M	M	M	M	M	M	M	M	M	M	M	M	M	M	M	M	M	M
J	J	J	J	J	J	J	J	J	J	J	J	J	J	J	J	J	J	J	J	J
J	J	J	J	J	J	J	J	J	J	J	J	J	J	J	J	J	J	J	J	J
A	A	A	A	A	A	A	A	A	A	A	A	A	A	A	A	A	A	A	A	A
S	S	S	S	S	S	S	S	S	S	S	S	S	S	S	S	S	S	S	S	S
O	O	O	O	O	O	O	O	O	O	O	O	O	O	O	O	O	O	O	O	O
N	N	N	N	N	N	N	N	N	N	N	N	N	N	N	N	N	N	N	N	N
D	D	D	D	D	D	D	D	D	D	D	D	D	D	D	D	D	D	D	D	D

Just mark the appropriate box each time you perform routine maintenance.

One less thing you will have to try and remember on your busy schedule is whether or not you did the maintenance last month.

TROUBLESHOOTING

FOR HELP-1.800.354.3643 OR GENIECOMPANY.COM

STB SELF-DIAGNOSTIC TROUBLESHOOTING

SOURCE (RED LED)	SENSOR (GREEN LED)	INDICATED CONDITION	REQUIRED ACTION
● ON	● ON	NORMAL OPERATION	NONE REQUIRED
○ OFF	○ OFF	1. POWER HEAD NOT POWERED 2. WIRING FROM POWER HEAD BAD	1. CHECK BREAKERS, FUSES, PLUGS 2. CHECK WIRING FOR OBVIOUS SHORTS
○ OFF	● ON	1. WIRING TO SOURCE MISSING OR BAD 2. POWER HAS BEEN INTERRUPTED	1. CHECK WIRING 2. REMOVE POWER AND REAPPLY
2 BLINKS, PAUSE (REPEAT)	● ON	1. BEAM NOT ALIGNED 2. BEAM OBSTRUCTED 3. SENSOR DEFECTIVE	1. CHECK ALIGNMENT 2. CHECK FOR OBSTRUCTION 3. CALL CUSTOMER SERVICE
2 BLINKS, PAUSE (REPEAT)	○ OFF	1. WIRE TO SENSOR MISSING OR BAD 2. SENSOR DEFECTIVE	1. CHECK WIRING 2. CALL CUSTOMER SERVICE
3 BLINKS, PAUSE (REPEAT)	● ON	1. SENSOR RECEIVING INTERFERENCE	1. ATTEMPT TO DETERMINE SOURCE OF INTERFERENCE 2. CALL CUSTOMER SERVICE
4 BLINKS, PAUSE (REPEAT)	● ON	1. SOURCE NOT SENDING PULSES 2. SOURCE DEFECTIVE	1. CALL CUSTOMER SERVICE 2. CALL CUSTOMER SERVICE

NOTE: IF OPERATING PROBLEM EXISTS, THE DOOR CAN BE CLOSED IF YOU: 1. DISCONNECT THE STB SYSTEM FROM THE OPERATOR AND 2. HOLD WALL CONTROL BUTTON DOWN UNTIL DOOR IS CLOSED. (REMOTE CONTROL & WIRELESS KEYPAD WILL NOT WORK WITHOUT STB)

CUSTOMER SERVICE: 1.800.354.3643 or www.geniecompany.com

MAINTENANCE & TROUBLESHOOTING

Use this guide to correct problems with your door operator. If these solutions **do not** work, call Customer Service.

32

⚠ CAUTION

Use only with included **SERIES II** wall control
Use of any other wall control can cause the door to operate unexpectedly and the light not to work.

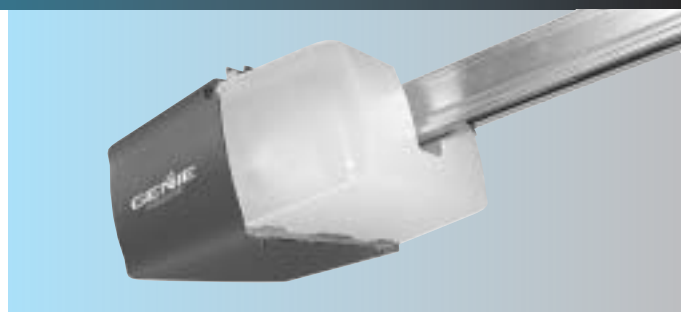

PROBLEM	SOLUTIONS
Operator does not run from wall control.	<p>Check lock switch on wall console (See section 4). Check the power source.</p> <ul style="list-style-type: none"> • Plug a lamp into outlet used for power head. If lamp works, power source is OK. If not, check fuse or circuit breaker. • If power is OK: <ul style="list-style-type: none"> - Check connections at power head terminals. - Check connections at wall control. - Motor protector may be open. Wait about 20 minutes for protector to reset.
Door starts for no reason.	<p>Check staples on wire from power head to wall control. If they cut into insulation, they can short wires. If wire is cut, replace it. Was a remote control lost or stolen? Erase all remote control codes from receiver memory and reprogram. Wall control button sticking. Check operation of buttons.</p>
Door starts down, then stops before it's closed.	<p>Check CLOSE limit switch setting (See Section 7) Check for shorted wires</p>
Door starts down, then stops and goes back up.	<p>Check force adjustment (See Section 7). Check CONTACT REVERSE (See Section 7). Check for light beam obstruction or misalignment of Safe-T-Beam® (See Section 3). Check STB self-diagnostic code.</p>
Door will only run closed.	<p>Check OPEN limit switch for short and proper wiring. Check force adjustment (See section 7). Check for broken door spring.</p>
Door will only run open.	<p>Check Safe-T-Beam® System (See section 3). Check CLOSE limit switch for short and proper wiring. Check force adjustment (See Section 7).</p>
Remote control has less than 25 feet operating range.	<p>Relocate remote control inside car. Point remote control at door. Replace battery. Do Not attempt to retune remote controls.</p>
Door starts up, but stops before it's completely open.	<p>Be sure door is in good repair, properly lubricated and balanced. Check OPEN limit switch setting (See section 7). Check force adjustment (See section 7). Check for broken door spring.</p>
Operator runs, but door does not move.	<p>Make sure carriage is engaged. Check force adjustment (See Section 7).</p>
Operator works from wall control, but not from remote control.	<p>Program remote control code into receiver memory (See section 9). If one remote control works and another does not, check battery, remote control type (Series II) and frequency of non-working unit (See section 9).</p>
Noisy operation.	<p>Be sure all fasteners are tight. Be sure door is in good repair, properly lubricated and balanced (See Monthly Maintenance section).</p>
STB System malfunction.	<p>Use self-diagnostic STB System troubleshooting information to maintain safe operation (See section 3).</p>
Lights will not go out.	<p>Check wiring. Disconnect & reconnect wires on wall control. Non-compatible wall control.</p>

The Genie Company Professional Access Systems LIMITED WARRANTY

What is covered: Any defect in material and workmanship from personal, normal household use in accordance with the Owner's Manual.

For how long:

H4000A-2 Series . . . Motor 10 years and all other parts 2 years.
H6000A-2K Series . . . Motor 15 years and all other parts 3 years.
IS525 Series Motor 2 years and all other parts 2 years.
IS550-1 Series Motor 7 years and all other parts 2 years.
IS550-2 Series Motor 10 years and all other parts 2 years.
IS550-2X Series Motor 12 years and all other parts 2 years.
IS850-2M Series Motor Lifetime* and all other parts 3 years.
IS900-1 Series Motor 10 years and all other parts 2 years.
IS900-2 Series Motor Lifetime* and all other parts 2 years.
IS920 Series Motor Lifetime* and all other parts 2 years.
ISL950 Series Motor Lifetime* and all other parts 3 years.
ISL980 Series Motor and all other parts Lifetime*.
CM7600 Series Motor 10 years and all other parts 3 years.
CM8600 Series Motor Lifetime* and all other parts 5 years.
PRO 95 Series Motor and all other parts Lifetime*.

*Lifetime warranty - warranted for as long as you own your home.

Who Gets the Warranty: The warranty is limited to the consumer who originally purchased the product.

Geographic Scope: This warranty applies only to Genie products purchased in the United States and Canada.

What we will do: If your Genie product is defective, we will send replacement parts or, at our option, replace it at no charge to you. If we send replacement parts for your Genie product, we may use new or reconditioned replacement parts. If we choose to replace your Genie product, we may replace it with a new or reconditioned one of the same or similar design.

Limitations: IMPLIED WARRANTIES, INCLUDING THOSE OF FITNESS FOR A PARTICULAR PURPOSE AND MERCHANTABILITY (AN UNWRITTEN WARRANTY THAT THE PRODUCT IS FIT FOR ORDINARY USE) ARE LIMITED TO ONE YEAR FROM DATE OF PURCHASE. GENIE WILL NOT PAY FOR; LOSS OF USE OF YOUR GENIE PRODUCT OR PROPERTY DAMAGE CAUSED BY YOUR GENIE PRODUCT OR ITS FAILURE TO WORK; ANY SPECIAL, INCIDENTAL OR CONSEQUENTIAL DAMAGES; ANY DAMAGES RESULTING FROM MISUSE OR MODIFICATION OF YOUR GENIE PRODUCT.

Some states and provinces do not allow limitations on how long an implied warranty lasts or the exclusion of incidental or consequential damages, so the above exclusions may not apply.

How to get Warranty Service: To get warranty service for your Genie product, you must provide proof of date, and place of purchase of the product.

1. Do-It-Yourself-Service: Call Genie Consumer Connection toll free at 1-800-354-3643. Trained Genie representatives will assist in diagnosing the problem and will arrange to supply you with required parts for do-it-yourself repairs. Trained service representatives are available Monday-Friday, 8:00 AM - 11:00 PM, and on Saturday, 11:00 AM - 8:00 PM Eastern Time (subject to holidays.)

2. Service From Authorized Dealers: You can obtain the name of a Genie authorized dealer by calling the Genie Consumer Connection at 1-800-654-3643. If an authorized dealer provides warranty service, Genie will not reimburse you or otherwise be responsible for those charges.

Your choice of any one of the above described service options is your remedy under this warranty.

What This Warranty Does Not Cover: This warranty does not cover batteries (which are considered replaceable parts,) installation, commercial use, defects resulting from accidents, damage while in transit to our service location or damage resulting from alterations, misuse or abuse, lack of proper maintenance, unauthorized repair or modifications of the product, affixing of any attachment not provided with the product, programming of the Remote Control Devices, Safe-T-Beam® adjustment/cleaning, staples through wiring, pinched or broken wires, Carriage disengaged, Force Control adjustments, door out of balance, broken springs or cables, power outages, use of extension cords, missing or damaged parts on discounted, clearance, final sale or taped cartons, phantom operations (labor is not covered if Opener is functioning properly while technician is in garage), fire, flood, acts of God, or failure to follow the Owner's Manual.

This warranty is the only one we will give on your Genie product, and it sets forth all our responsibilities regarding your Genie product. There are no other express warranties. **State and Province Rights:** This warranty gives you specific legal rights, and you may also have other rights that vary from state to state and province to province.

Visit Our Website at:
www.geniecompany.com

Sistemas de acceso profesional de Genie Company GARANTÍA LIMITADA

Lo que está cubierto: todo defecto en materiales y mano de obra en el uso doméstico personal y normal de acuerdo con el Manual del Propietario.

Duración:

Serie H4000A-2 . . . Motor 10 años y todas las demás piezas 2 años.
Serie H6000A-2K . . . Motor 15 años y todas las demás piezas 3 años.
Serie IS525 Motor 2 años y todas las demás piezas 2 años.
Serie IS550-1 Motor 7 años y todas las demás piezas 2 años.
Serie IS550-2 Motor 10 años y todas las demás piezas 2 años.
Serie IS550-2X Motor 12 años y todas las demás piezas 2 años.
Serie IS850-2M Motor Lifetime* y todas las demás piezas 3 años.
Serie IS900-1 Motor 10 años y todas las demás piezas 2 años.
Serie IS900-2 Motor Vitalicia* y todas las demás piezas 2 años.
Serie IS920 Motor Vitalicia* y todas las demás piezas 2 años.
Serie ISL950 Motor Vitalicia* y todas las demás piezas 3 años.
Serie ISL980 Motor y todas las demás piezas Vitalicia*.
Serie CM7600 Motor 10 años y todas las demás piezas 3 años.
Serie CM8600 Motor Vitalicia* y todas las demás piezas 5 años.
Serie PRO 95 Motor y todas las demás piezas Vitalicia*.

*Garantía Vitalicia - se garantiza mientras usted sea el propietario de su casa.

¿Quién obtiene la garantía? La garantía está limitada al consumidor que compró originalmente el producto.

Alcance geográfico: Esta garantía se aplica sólo a los productos Genie comprados en los Estados Unidos y Canadá.

Lo que haremos: Si su producto Genie es defectuoso, mandaremos el reemplazo los partes o, a opción nuestra, lo reemplazaremos sin cargo alguno para usted. Si mandamos el reemplazo las partes su producto Genie, podemos usar piezas de reemplazo nuevas o reacondicionadas. Si optamos por cambiar su producto Genie, podemos cambiarlo por uno nuevo o reacondicionado del mismo diseño o similar.

Limitaciones: LAS GARANTÍAS IMPLÍCITAS, INCLUYENDO AQUELLAS DE CONVENIENCIA PARA UN PROPOSITO PARTICULAR Y COMERCIALIZACIÓN (UNA GARANTÍA NO ESCRITA QUE EL PRODUCTO ES APROPIADO PARA USO ORDINARIO) ESTÁN LIMITADAS A UN AÑO A PARTIR DE LA FECHA DE COMPRA. GENIE NO PAGARÁ POR PÉRDIDA DEL USO DE SU PRODUCTO GENIE O POR DAÑOS DE PROPIEDAD CAUSADOS POR SU PRODUCTO GENIE O POR LA FALTA DE TRABAJAR; POR DAÑOS CUALESQUIERA ESPECIALES, INCIDENTALES O EMERGENTES; POR DAÑOS RESULTANTES DEL MAL USO O LA MODIFICACIÓN DE SU PRODUCTO GENIE.

Algunos estados y provincias no permiten limitaciones del tiempo que dura la garantía implícita o la exclusión de daños incidentales o circunstanciales, entonces puede que las limitaciones de arriba no se apliquen.

Cómo obtener servicio de garantía: Para obtener servicio de garantía para su producto Genie, usted debe proporcionar prueba de la fecha y lugar de la compra del producto.

1. Servicio de bricolaje: Llamar sin cargo a la conexión del consumidor de Genie, marcando el 1-800-354-3643. Representantes entrenados de Genie le asistirán en diagnosticar el problema y harán arreglos para suministrarle las piezas necesarias para las reparaciones de bricolaje o sea que usted mismo haga. Los representantes de servicio entrenados están disponibles de lunes a viernes, de 8:00 a.m. a 11:00 p.m. y los sábados de 11:00 a.m. a 8:00 p.m. hora del Este (sujeto a feriados).

2. Servicio de distribuidores autorizados: Usted puede obtener el nombre del distribuidor autorizado de Genie llamando a la conexión del consumidor de Genie, marcando el 1-800-654-3643. Si un distribuidor autorizado extiende una garantía de servicio, Genie no le reembolsará a usted ni será responsable por esos cargos.

Su elección de cualesquiera de las opciones de los servicios descritos arriba es el recurso que tiene bajo esta garantía.

Qué Esta Garantía no Cubre: Esta garantía no cubre baterías (que considera las partes reemplazables,) la instalación, el uso de la propaganda, los defectos resultando de accidentes, el daño mientras en tránsito a nuestra ubicación del servicio o resultar de daño de modificaciones, el maltrato o el abuso, la falta de la conservación apropiada, la reparación o las modificaciones no autorizadas del producto, poner de ninguna fijación no proporcionó con el producto, programar de los Dispositivos del Mando a distancia, de T de Rayo Segura® el ajuste/limpieza. Los alambres pellicados o rotos, el Coche soltó, los ajustes del Control de la Fuerza, la puerta fuera de equilibrio, los primavera o los cables rotos, las fallas del poder, el uso de cuerdas de extensión, perdiendo o las partes dañadas en descuento, clearance, la venta final o los cartones grabados, las operaciones fantasmales (el trabajo no se cubre si el Abrelatas funciona apropiadamente mientras técnico está en el garaje), el fuego, la inundación, los actos de la naturaleza, o el fra.

Esta garantía es la única que daremos a su producto Genie, y estipula todas nuestras responsabilidades con respecto a su producto Genie. No hay otras garantías expresas.

Derechos de estados y provincias: Esta garantía le otorga derechos legales específicos y puede que usted tenga también otros derechos que varían de estado a estado y de provincia a provincia.

Visitar "Website" nuestro en:
www.geniecompany.com

LA GARANTIE DE LA Systèmes d'accès Professionnels The Genie Company

Ce qu'elle couvre: toute défectuosité de matériau et tout défaut de fabrication constatés pendant l'utilisation normale du produit par un individu à son domicile en conformité avec le Manuel de l'utilisateur.

Pendant combien de temps:

Série H4000A-2 . . . Moteur 10 ans et toutes les autres pièces 2 ans.
Série H6000A-2K . . . Moteur 15 ans et toutes les autres pièces 3 ans.
Série IS525 Moteur 2 ans et toutes les autres pièces 2 ans.
Série IS550-1 Moteur 7 ans et toutes les autres pièces 2 ans.
Série IS550-2 Moteur 10 ans et toutes les autres pièces 2 ans.
Série IS550-2X Moteur 12 ans et toutes les autres pièces 2 ans.
Série IS850-2M Moteur à vie* et toutes les autres pièces 3 ans.
Série IS900-1 Moteur 10 ans et toutes les autres pièces 2 ans.
Série IS900-2 Moteur à vie* et toutes les autres pièces 2 ans.
Série IS920 Moteur à vie* et toutes les autres pièces 2 ans.
Série ISL950 Moteur à vie* et toutes les autres pièces 3 ans.
Série ISL980 Moteur et toutes les autres pièces à vie*.
Série CM7600 Moteur 10 ans et toutes les autres pièces 3 ans.
Série CM8600 Moteur à vie* et toutes les autres pièces 5 ans.
Série PRO 95 Moteur et toutes les autres pièces à vie*.

*Garantie à vie - Garanti tant que vous restez propriétaire de votre habitation.

Bénéficiaire de la garantie: La garantie est limitée au client qui a acheté initialement le produit.

Pays couverts: Cette garantie s'applique seulement aux produits Genie achetés aux états-Unis et Canada.

Nos conditions: Si le produit Genie est défectueux, nous enverrons les parties de remplacement ou, selon notre choix, de le remplacer sans frais de votre part. Si nous envoyons les parties de remplacement du produit, il est possible que nous utilisions des pièces de remplacement neuves ou reconditionnées. Si nous décidons de remplacer le produit Genie, il est possible que nous le remplaçons avec un produit neuf ou reconditionné de conception semblable.

Limites: LES GARANTIES IMPLÍCITES, Y COMPRIS LES GARANTIES D'A-DAP-TATION À UN USA-GE PAR-TI-CU-LIER ET LA GA-RAM-TIE DE VALIDITÉ MAR-CHAN-DE (UNE GARANTIE TACITE QUE LE PRODUIT EST ADAPTÉ À L'USAGE) SONT LIMITÉES À UN AN À COMPTER DE LA DATE D'ACHAT. GENIE DÉCLINE TOUTE RESPONSABILITÉ EN CAS DE PERTE D'UTILISATION DU PRODUIT OU DE DOMMAGES MATÉRIELS CAUSÉS PAR LE PRODUIT GENIE OU PAR UN FONCTIONNEMENT DÉFECTUEUX ; DE DOMMAGES ACCIDENTELS OU INDIRECTS ; DE DOMMAGES ISSUS DE L'UTILISATION INCORRECTE OU DE LA MODIFICATION DU PRODUIT GENIE.

Certains états et provinces n'autorisent pas les limites de durée des garanties implicites ou l'exclusion des dommages accidentels ou indirects. Dans ce cas, les exclusions ci-dessus ne s'appliquent pas.

Comment bénéficier du service offert par la garantie: Pour pouvoir en bénéficier, il vous faut fournir une justification de la date et du lieu de l'achat.

1. Service pour effectuer les réparations soi-même: Appeler le numéro sans frais du service à la clientèle Genie 1-800-354-3643. Des agents Genie spécialisés vous aideront à diagnostiquer le problème et prendront les dispositions nécessaires pour vous fournir les pièces requises afin que vous puissiez effectuer les réparations par vous-même. Vous pouvez joindre ce service du lundi au vendredi, de 8 h à 23 h et le samedi, de 11 h à 20 h, heure de l'Est (sauf jours fériés)

2. Service effectué par des techniciens agréés: Appeler le service à la clientèle Genie au 1-800-654-3643 qui vous communiquera le nom d'un technicien agréé. Si le technicien agréé offre un service de garantie, les frais encourus ne seront pas remboursés par Genie et Genie ne sera pas tenu responsable du règlement des frais.

Le choix de l'une des options de service décrite ci-dessus est le recours dont vous disposez sous cette garantie.

Que Cette Garantie Pas Couverture: Cette garantie pas piles couverture (qui sont-ils considéré des parties remplaçables,) installation, usage *, défauts Rayon résulter de accidents, dommages * dans traversée à notre emplacement service ou pas dommages qui résulte de changements, * ou abus, manque d'entretien propre, réparation ou modifications inautorisée du produit, aposant d'attachement ont fourni avec le produit, programant de H, de T de Rayon Sûr® ajustement nettoyage, fils pincés ou cassés, l'Attelage a déclenché, les ajustements de Contrôle de Force, la porte d'équilibre, les ressort ou les câbles cassés, les coupures de courant, l'usage de rallonges, manquant ou a endommagé des parties sur escompté, clearance, la vente finale ou a enregistré des boîtes, les opérations fantômes (la main-d'oeuvre n'est pas couverte si l'Ouvre-boîte fonctionne convenablement pendant que le technicien est dans le garage), le feu, l'inondation, les désastres naturels, ou l'échec pour suivre le Manuel du Propriétaire.

Cette garantie est la seule garantie fournie pour le produit et fait valoir toutes les responsabilités qui vous incombent concernant le produit Genie. Il n'y a pas d'autres garanties expresas.













Droits pour les états et les provinces: Cette garantie vous donne des droits juridiques spécifiques; les autres droits peuvent varier d'un état à l'autre et d'une province à l'autre.

Visite "Website" notre en:
www.geniecompany.com

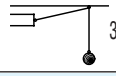
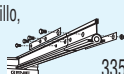

Garage Door Operator Accessories Order Form
Formulario de pedido de accesorios para abridores de puertas de garaje
Formulaire de commande des accessoires pour ouvre-porte de garage

AVAILABLE AT YOUR LOCAL DISTRIBUTOR—DISPONIBLE POR SU DISTRIBUIDOR LOCAL—DISPONIBLE AUPRÈS DE VOTRE DISTRIBUTEUR LOCAL

MODEL MODELO MODÈLE	DESCRIPTION / PRODUCT CODE DESCRIPCIÓN / CÓDIGO DESCRIPTION / CODE DU PRODUIT	PRICE (US\$)* PRECIO* PRIX (\$ US)*	QTY. CANTIDAD QTÉ	SUBTOTAL SUBTOTAL SOUS-TOTAL
GIT-1	Deluxe Remote Control with Intellicode®. Allows remote operation of garage door. Controlador remoto de lujo con Intellicode®- Proporcionar operación remoto de la puerta del garaje. Télécommande de luxe avec Intellicode®- Permettre opération éloigné de porte de garage.	 33069R	\$34.95	
GIT-2	2-Button Remote Control with Intellicode®. Allows remote operation of 2 garage doors. Controlador remoto de 2 funciones con Intellicode®- Proporcionar operación remoto de dos las puertas del garaje. Télécommande à 2 fonctions avec Intellicode®- Permettre opération éloigné deux portes de garage.	 33069S	\$44.95	
GIT-3	3-Button Remote Control with Intellicode®. Allows remote operation of 3 garage doors. Controlador remoto de 3 funciones con Intellicode®- Proporcionar operación remoto de tres las puertas del garaje. Télécommande à 3 fonctions avec Intellicode®- Permettre opération éloigné trois portes de garage.	 33069T	\$49.95	
GPWC-2WLB	Lighted Wall Console - Operates Garage Door. Independent light control. Security vacation lock. Consola de pared de 3 funciones - Acciona la puerta del garaje. Control de luz independiente. Cerradura de seguridad para vacaciones. Console murale à trois fonctions - Actionne la porte de garage. Commande d'éclairage indépendante. Interrupteur de verrouillage de sécurité.	 34292R	\$34.95	
GMI-3	3-Button Mini Remote Control with Intellicode® - Fits easily into pocket or purse. Minicontrolador remoto de 3 funciones con Intellicode® - Cave fácilmente en el bolsillo o cartera. Mini télécommande à 3 fonctions avec Intellicode® - se glisse dans la poche de veston ou le sac à main.	 34909R	\$39.95	
GWKP	Wireless Keypad Entry System - Operates Intellicode® Garage Door Operators without Remote Control or key. Sistema de entrada por teclado numérico inalámbrico - Acciona los abridores de puertas de garaje Intellicode® sin control remoto o llave. Système d'ouvre-porte de garage à clavier sans fil - Actionne les ouvre-porte de garage avec Intellicode® sans télécommande ni clé.	 35282R	\$49.95	
GLU-3	(3) 1/4 oz. tubes Screw Grease - Ensures proper equipment wear protection. (3) 1/4 ounce lubricante de tornillo accionar - Asegura componente correcto protección por deterioro. La onza 1/4 lubricant de la vis (3)- Garantir component exact par système défense vers user.	 35164R	\$1.95	
GWB	Universal Wall Button - Provides additional convenient inside operation of Door. Botón de pared universal - Proporciona operación conveniente de la puerta desde el interior. Bouton mural universel - Actionne l'ouvre-porte de l'intérieur du garage.	 34960R	\$ 4.95	
GPS-5	Perfect Stop® - Ensures perfect parking. Stop Perfecto® - Asegura el estacionamiento perfecto. Butoir Perfect Stop® - Permet de stationner à la perfection dans le garage.	 34964R	\$ 4.95	
GSX-8	Screw Drive Extension Kit - Eighteen inch Extension to increase travel of Screw Drive Operator to accommodate eight foot door. Juego de extensión deslizante de Screw Drive - Una extensión de 18 pulgadas para aumentar la carrera de un abridor deslizante de tornillo, para acomodar una puerta de 8 pies (2,43 m.). Nécessaire de rallonge du Screw Drive - Rallonge de 30 dm (18 po) prolongeant la course de l'ouvre-porte Screw Drive pour une porte de 2,4 m (8 pi) de hauteur.	 33523R	\$34.95	
GIRU-1T	Universal Conversion Kit - Converts any Garage Door Operator to a secure radio signal system. Kit includes a Remote Control, Receiver and Transformer. Juego de conversión universal - Convierte cualquier abridor de puerta de garaje a un sistema de señal de radio seguro. El juego incluye un control remoto de abridor de puerta de garaje, receptor y transformador. Nécessaire de conversion universel - Transforme tout ouvre-porte de garage en système de sécurité à signal radio. Comprend une télécommande d'ouvre-porte de garage, un récepteur et un transformateur.	 33154R	\$49.95	
LIGHTBULB	60 WATT Enhanced/Rough Service Light Bulb - Ensures proper equipment compatibility. Bombilla de 60 Vatios - Asegura componente correcto de sistema. Éclairage de 60 WATT - Garantir component exact par système.	 26210A.S	\$2.95	
GER-2	Emergency Release Kit - Provides access to garage from outside in the event of an electrical power failure. Juego de pica-porte de pestillo - Permitir entrada desde por fuera de garaje porque corte de eléctrico. Nécessaires de Déclenchement de secours - Le nécessaire de déclenchement de secours est conçu pour vous permettre d'accéder à votre garage depuis l'extérieur en cas de panne de courant et lorsqu'il.	 34963R	\$29.95	
ADAPTER BRACKET	STB Adapter Brackets (2) - Used in conjunction with standard STB mounting brackets, they provide additional clearance along with mounting options. Bras adaptador por STB(2) - Usado con bras normal por STB, proveer espacio adicional. Supports raccord du STB (2) - Se servir en compagnie de supports normal du STB, assurer espace supplémentaire.	 34439R.S	\$4.95	

No C.O.D. shipments. Please include check or money order, do not send cash. Allow 3-4 weeks for delivery. We accept Visa or Mastercard phone orders. 1.800.354.3643. Please have part number and credit card ready

No se aceptan pedidos de pago contra entrega (COD). Sirvase incluir su cheque o giro postal; no envíe dinero en efectivo. Concedáanos 3 a 4 semanas para la entrega. Aceptamos pedidos telefónicos de Visa o Mastercard. 1.800.354.3643. Sirvase tener listos los números del modelo y de la tarjeta de crédito.

Pas d'expédition contre remboursement. Veuillez inclure un chèque ou un mandat bancaire. N'envoyez pas d'argent comptant. Accordez de 3 à 4 semaines pour la livraison. Nous acceptons les commandes par téléphone avec paiement par carte de crédit Visa ou Mastercard. 1.800.354.3643. Ayez sous la main le numéro de la pièce et celui de la carte de crédit.

TOTAL ORDER / TOTAL DEL PEDIDO / COMMANDE TOTALE	\$
SHIPPING & HANDLING / FLETE Y MANEJO / MANUTENTION ET EXPÉDITION	\$ 5.00
STATE SALES TAX / IMPUESTO DE VENTAS ESTATAL / TAXE DE VENTE	\$
GRAND TOTAL / GRAN TOTAL / TOTAL GLOBAL	\$

Please add local sales tax if you reside in one of the states listed.

- | | | | | |
|-------------|----------|---------------|-----------|-----------|
| California | Georgia | Maryland | New York | Virginia |
| Connecticut | Illinois | Massachusetts | Ohio | Wisconsin |
| Florida | Indiana | New Jersey | Tennessee | |

MAIL ORDER FORM TO:
 ENVIAR HACER UN PEDIDO DE MERCANCIA A:
 METTRE À LA POSTE LE ARRANGEMENT À:

SHIP ORDER TO: / ENVIAR MERCANCIA CON: / EXPÉDIER MARCHANDISE POUR:

NAME / NOMBRE / NOM			
ADDRESS / DIRECCIÓN / ADRESSE			
CITY / CIUDAD / VILLE	STATE / ESTADO / ÉTAT	ZIP / CÓDIGO POSTAL / CODE POSTAL	

The Genie Company
 22790 Lake Park Blvd.
 Alliance, Ohio 44601

