



HP **DesignJet 1050C/1055CM** **Large-Format Printers**



Service Manual

For HP Internal Use Only

©Copyright Hewlett-Packard Company 1999

This document contains proprietary information that is protected by copyright. All rights are reserved. No part of this document may be photocopied, reproduced, or translated to another language without the prior written consent of Hewlett-Packard Company.

First Edition, March 1999

Warranty

The information contained in this document is subject to change without notice.

Hewlett-Packard makes no warranty of any kind with regard to this material, including, but not limited to, the implied warranties of merchantability and fitness for a particular purpose.

Hewlett-Packard shall not be liable for errors contained herein or for incidental or consequential damages in connection with the furnishing, performance, or use of this material.

WARNING

The procedures described in this manual are to be performed by HP-qualified service personnel only.

Electrical Shock Hazard

Serious shock hazard leading to death or injury may result if you do not take the following precautions:

- Ensure that the ac power outlet (mains) has a protective earth (ground) terminal.
- Disconnect the Printer from the power source prior to performing any maintenance.
- Prevent water or any other liquids from running onto electrical components or circuits, or through openings in the enclosure.

Electrostatic Discharge

Refer to the beginning of Chapter 8 of this manual, for precautions you should take to prevent damage to the Printer circuits from electrostatic discharge.

Safety Symbols

General definitions of safety symbols are given immediately after the table of contents.

WARNING

The Warning symbol calls attention to a procedure, practice, or the like, which, if not correctly performed or adhered to, could result in personal injury. Do not proceed beyond a Warning symbol until the indicated conditions are fully understood and met.

CAUTION

The Caution symbol calls attention to an operating procedure, practice, or the like, which, if not correctly performed or adhered to, could result in damage to or destruction of part or all of the product. Do not proceed beyond a Caution symbol until the indicated conditions are fully understood and met.

Technical Marketing,
Barcelona Division,
Hewlett-Packard Espanola, S.A.
Avda. Graells, 501
08190 Sant Cugat del Valles
Spain

HP

DesignJet 1050C/1055CM

Large-Format Printers



Service Manual

Using this Manual

Purpose

This Service Manual contains information necessary to test, calibrate and service:

- HP DesignJet 1050C Printer (Model C6074A)
- HP DesignJet 1055CM Printer (Model C6075A)

For information about using these printers, refer to the corresponding User and Quick Reference Guides.

Readership

The procedures described in this Service Manual are to be performed by HP Certified service personnel only.

Part Numbers

Part Numbers for Printer options, accessories and service parts are located in Chapter 7.

Conventions

A small arrow \Rightarrow is used to indicate other parts of the Service Manual where you can find information related to the topic you are consulting.

Table of Contents

Troubleshooting 1-1

Introduction	1-2
Troubleshooting System Error Codes	1-2
Performing a Service Test on a Failed Assembly	1-3
Performing the Necessary Service Calibrations	1-3
Solving Image Quality Problems	1-3
Front-Panel LEDs Flash Briefly at Power ON & Nothing Else Happens	1-4
The Printer does not Power ON	1-5
ALL the Front-Panel LEDs are Lit but Nothing Else Happens	1-5
One of the Print Quality LEDs on the Front Panel is Lit (and nothing else) and the "SELF TEST..." Message Remains on the Front Panel	1-5
The Printer Continuously Rejects Printheads	1-6
Cover Sensors are not Working	1-6
The Line Sensor has Problems Detecting Media	1-6
Troubleshooting Media Jams/Printhead Crashes	1-7
Troubleshooting Shutdowns	1-7
Problems with the Vacuum Fan	1-9
Vacuum suction much lower at high altitudes	1-9
Bin marks on prints done on HP High Gloss media	1-9
Printhead Crashes/Smears on High Density Prints Using Coated Media	1-10
Color changes when stacking prints done on HP High Gloss Media	1-10
HP-GL/2 color differences in different HP DesignJet Printers	1-11
Scratches on prints done on NTP, Vellum and HP High Gloss media	1-11
Banding at variable extreme environmental conditions	1-12
Banding due to Ink Cartridge replacement while printing	1-12
Long term bleed and hue shift on HP High Gloss media	1-12
Lower image gloss directly after printing on HP High Gloss Photo Paper	1-13
34" Rice Paper not supported	1-13
Cut Sheet rice paper loading failure	1-13
Worm marks on HP Coated media with light area fills	1-13
Solving Media-Handling Problems	1-14
How to Navigate through the Front-Panel Menu	1-15
Service Configuration Print	1-19

System Error Codes 2-1

Introduction 2-2

Continuable and Non-Continuable Error Codes 2-2

System Error Codes During Initialization 2-18

HP No.80 Ink Supplies Troubleshooting 3-1

What are HP No.80 Supplies? 3-2

Ink Cartridges 3-2

Printheads and Printhead Cleaners 3-2

Identifying the Components 3-3

General Information About HP No.80 Supplies 3-4

Some General Precautions When Handling HP No.80 Supplies 3-5

Priming the Ink System 3-6

When Should You Replace the HP No.80 Supplies? 3-6

The Front Panel Display 3-7

Obtaining Ink Cartridge Information 3-8

Obtaining Printhead Information 3-9

Ink Cartridge Status Messages 3-11

Ink Cartridge Status While Printing 3-11

Ink Cartridge Status While Replacing 3-12

Printhead Status Messages While Printing 3-13

Printhead Status Messages While Replacing 3-15

Summary of Solving HP No.80 Supplies Problems 3-17

Carriage Interconnect Wiper 3-18

Service Tests and Utilities 4-1

Service Tests (Diagnostics) 4-3

Entering the Service Tests Menu 4-4

1. Electronic Systems 4-5
2. EIO Card 4-10
3. Hard Disk Drive 4-12
4. Ink Pressure System 4-14
5. Scan Axis 4-17
6. Paper Axis 4-20
7. Drop Detector 4-22

Service Utilities 4-25

Entering the Service Utilities Menu 4-26

1. Tubes Purge 4-28
2. Release Info 4-32
3. Set Asian PS Fonts 4-33
4. Printer Model Type 4-35
5. Overdrive Cleaning 4-37
6. EEROM Utilities 4-38
7. Printhead Check 4-41
8. Mon. Mode Baud Sel. 4-42

Service Calibrations 5-1

Service Calibrations 5-2

Entering the Service Calibrations Menu 5-4

1. Accuracy Calibration 5-6
2. Line Sensor 5-9
3. Service Station 5-11
4. Roller Mark Position 5-13
5. Pen to Paper Spacing 5-15
6. Color to Color calibration 5-16
7. Calibrations Backup 5-19
8. Pen Alignment 5-22

Carriage Height Calibration 5-24

Print Quality 6-1

Print Quality Troubleshooting Checklist	6-2
Print Modes	6-3
How to Use the Print Quality Test	6-4
What is the Print Quality Test?	6-4
Considerations for Printing the Print Quality Test.	6-4
Printing the Print Quality Test	6-4
Nozzle Print Test	6-6
How to fix the Nozzle Defects	6-7
Color Alignment Print Test	6-7
Solving the Color Alignment Problem	6-8
Overall Print Quality Test in BEST mode	6-9
What is Banding?	6-9
Solving the Banding Problem	6-10
Aligning the Printheads	6-12
Service Accuracy Calibration	6-12
Troubleshooting Print Quality Problems	6-13
Problems with Stepped Lines	6-13
Problems with printing lines	6-14
Problems with Color-to-Color Alignment	6-15
Problems with Horizontal Lines (Banding)	6-17
No Printing Defects Found in the Print Quality Test	6-21
Solving Color Accuracy problems	6-22
Color Consistency problems	6-22
Long Term Color Bleeding (Glossy Papers)	6-22
Color Accuracy Configuration	6-23
Media	6-24
There are Smears or Scratching on the Printed Media	6-24

Parts and Diagrams 7-1

Printer Support	7-2
Rear Covers	7-4
Electronics Module	7-6
Right Hand Cover	7-8
Left Hand Cover and Window	7-10
Right Hand Assemblies	7-12
ISS and APS Assembly	7-14
Clutch Assembly	7-16
Carriage Assembly	7-18
Scan-Axis Assemblies	7-20
Drive Roller and ARSS Miscellaneous Parts	7-22
Paper Path Assemblies	7-24
Pinch Assembly	7-26
Drive Roller Assemblies	7-28
Center Guide and Media Sensor	7-30
Tubes Guide Assemblies	7-32
Ordering Accessories	7-34

Removal and Installation 8-1

Introduction	8-2
Safety Precautions	8-2
Electrostatic Discharge (ESD) Precautions	8-3
Required Tools	8-3
Right Hand Cover	8-4
Front Panel Assembly	8-6
Right Hand Trim and Window Switch	8-7
Service Station Assembly	8-8
Drop Detector Assembly	8-10
Vacuum Fan	8-11
Paper-axis Motor Assembly	8-12
Left Hand Cover	8-13
Left Hand Trim Assembly	8-18
Ink Supply Station Assembly (ISS)	8-19
Air Pressurization System (APS)	8-20
Clutch Assembly and left hand miscellaneous parts	8-21
Tail Deflectors and Rear Platen	8-23
Left and Right Rear Covers	8-24

- Electronics Module 8-25
- Media Sensor 8-29
- Window 8-30
- Top Cover 8-31
- Back Cover 8-32
- Scan-axis Motor Assembly 8-33
- Encoder Strip 8-34
- Tensioner 8-37
- Trailing Cable 8-39
- Cutter Assembly 8-42
- Carriage Assembly and Belt 8-44
- Tubes System Assembly 8-53
- Ink Leak Detector Assembly 8-60
- Front Platen Assembly 8-62
- Platen Assembly 8-63
- Paper Entry Assembly 8-64
- Roller Guide 8-66
- Media Holder Strip 8-69
- Drive Roller 8-70
- Center Guide 8-71
- Pinch-Wheel Assembly and Cam 8-73

Preventive Maintenance 9-1

- Moisture on the Printer 9-2
- Noisy Carriage Bushing 9-2
- Belt Swelling 9-2
- Cleaning the Printer 9-2
- General Cleaning 9-2
- Cleaning the Overdrive 9-3
- Scheduled Maintenance 9-3
- Level of Printer Usage 9-3
- Scan-axis Maintenance 9-4

Functional Overview 10-1

Introduction	10-2
HP DesignJet 1050C Printer	10-2
HP DesignJet 1055CM printer	10-2
Electrical System	10-2
Power Supply Unit (PSU)	10-3
Soft Power-Off Switch	10-4
Front Panel	10-4
Ink Delivery System (IDS)	10-5
Ink Supply Station (ISS)	10-5
Tubes System	10-6
Air Pressurization System (APS)	10-7
Ink Level Sense (ILS)	10-7
Leak Detect System (LDS)	10-8
Service Station	10-9
Print Head Cleaner (PHC)	10-9
Printer Specifications	10-12
Printable Area	10-16
Interface Specifications	10-17
Regulatory Notices	10-18
To Obtain a Material Safety Data Sheet (MSDS)	10-18
Sound	10-18
Electro-Magnetic Compatibility (EMC)	10-18
VCCI Class A and Class B (Japan)	10-21
Declaration of Conformity	10-22
www.designjet-online.hp.com	10-23

Glossary

Index

Table of Contents

Troubleshooting

1

Introduction	1-2
Troubleshooting System Error Codes	1-2
Performing a Service Test on a Failed Assembly	1-3
Performing the Necessary Service Calibrations	1-3
Solving Image Quality Problems	1-3
Front-Panel LEDs Flash Briefly at Power ON & Nothing Else Happens	1-4
The Printer does not Power ON	1-5
ALL the Front-Panel LEDs are Lit but Nothing Else Happens	1-5
One of the Print Quality LEDs on the Front Panel is Lit (and nothing else) and the "SELF TEST..." Message Remains on the Front Panel	1-5
The Printer Continuously Rejects Printheads	1-6
Cover Sensors are not Working	1-6
The Line Sensor has Problems Detecting Media	1-6
Troubleshooting Media Jams/Printhead Crashes	1-7
Troubleshooting Shutdowns	1-7
Problems with the Vacuum Fan	1-9
Vacuum suction much lower at high altitudes	1-9
Bin marks on prints done on HP High Gloss media	1-9
Printhead Crashes/Smears on High Density Prints Using Coated Media	1-10
Color changes when stacking prints done on HP High Gloss Media	1-10
HP-GL/2 color differences in different HP DesignJet Printers	1-11
Scratches on prints done on NTP, Vellum and HP High Gloss media	1-11
Banding at variable extreme environmental conditions	1-12
Banding due to Ink Cartridge replacement while printing	1-12
Long term bleed and hue shift on HP High Gloss media	1-12
Lower image gloss directly after printing on HP High Gloss Photo Paper	1-13
Cut Sheet rice paper loading failure	1-13
34" Rice Paper not supported	1-13
Worm marks on HP Coated media with light area fills	1-13
Solving Media-Handling Problems	1-14
How to Navigate through the Front-Panel Menu	1-15
Service Configuration Print	1-19

Guide to Troubleshooting the Printer

Introduction

This chapter will guide you through the relevant steps to take when troubleshooting the printer.

Troubleshooting System Error Codes

Chapter 2 - *System Error Codes* contains a list of system error codes and their respective descriptions and recommended corrective actions. Only try one recommended action at a time and check if the error code has disappeared.

If you have an error code which is not documented in this Service Manual or you have an error which you cannot resolve, then report the error to the HP Response Center or the nearest HP Support Office. When reporting the error, have the following information ready:

- Model and Serial Number of the printer.
- Which firmware revision the printer is using (See Note below).
Check firmware in *Utilities / Statistics / Code rev.*
- The complete error number (See Note below).
- The Service Configuration Print ⇒ Page 1-19
- The Current configuration sheet.
- Which software application the customer is using (name, version, etc.).

NOTE

When reporting the System Error Code, make sure that you supply the full Error Code (including the last 8 numbers where applicable) and the firmware version. Without this information, HP Support Personnel cannot help you.

Performing a Service Test on a Failed Assembly

If possible, always perform a Service Test on the component/assembly that you are about to replace, just to make sure that is the component/assembly that has failed.

NOTE

If the test on that component/assembly passes, you should NOT replace it.

For information on the Service Tests and how to use them see Chapter 4 - *Service Tests and Utilities*.

Performing the Necessary Service Calibrations

Is the printer calibrated correctly after replacing a component? Refer to the table on Page 5-2 to determine when a calibration is required.

NOTE

Remember that certain Calibrations are required even if an Assembly has been disassembled to gain access to another Assembly or Component.

For information on the Service Calibrations and how to use them see Chapter 5 - *Service Calibrations*.

Solving Image Quality Problems

Whenever an Image Quality problem appears, it is advisable to print the Image Quality Print to help diagnose the problem. The Image Quality Print will help you differentiate between possible printhead errors and other problems such as incorrect front-panel selection, driver or RIP configuration or mechanical problems. For information on solving Image Quality problems see Chapter 6 - *Print Quality*.

Front-Panel LEDs Flash Briefly at Power ON & Nothing Else Happens

The Power Supply detects a Short and shuts down the Power.

- 1 The Hard Disk Drive or the Network Card could be faulty. Troubleshoot the problem as follows:
 - a If the Printer has a Hard Disk Drive and/or a Network card installed, switch the Printer OFF from the back of the Printer, and remove them both.
 - b Switch the Printer ON again.
 - c If the Printer functions correctly now, switch the Printer OFF again and reinstall the Network Card correctly, making sure that the two installation screws are completely tightened.

NOTE

If the Printer DOES NOT function correctly with the Hard Disk Drive and the Network Card removed, then you must replace the Electronics Module.

- d Switch the Printer ON again
- e If the Printer functions correctly with the Network Card installed, switch the Printer OFF again.

NOTE

If the Printer DOES NOT function correctly with the Network Card installed, then you must replace it.

- f Reinstall the Hard Disk Drive correctly, making sure that the two installation screws are completely tightened.
- g Switch the Printer ON again
- h Check if the Printer functions correctly with the Hard Disk Drive installed.

NOTE

If the Printer DOES NOT function correctly with the Hard Disk Drive installed, then you must replace it.

- 2 Make sure that **none** of the cables connected to the Electronics Module have been pinched between the cover and the sideplate.

The Printer does not Power ON

- 1 Check that the power cord is connected correctly to the Printer and to the Power Socket.
- 2 Check that the Firmware DIMM is installed correctly in the correct slot (the first slot from the right) at the back of the Printer.
- 3 Check that the Power Switch on the BACK of the Printer is in the ON position.
- 4 Check that the Front-Panel Cable is correctly connected to the Electronics Module. Also make sure that the Front-Panel cable is not damaged.

ALL the Front-Panel LEDs are Lit but Nothing Else Happens

The Firmware DIMM is NOT correctly installed.

- 1 Power OFF the Printer from the back and disconnect the power cord. Reseat the Firmware DIMM (the first slot from the right) making sure that it is installed correctly.

One of the Print Quality LEDs on the Front Panel is Lit (and nothing else) and the "SELF TEST.." Message Remains on the Front Panel

One of the DRAM DIMMs is NOT correctly installed or Faulty.

- 1 Power OFF the Printer from the back and disconnect the power cord. Reseat both Firmware DIMMs (the first two slots from the left) making sure that they are installed correctly. If reseating the DRAM DIMMs does not solve the problem, replace them instead.

The Printer Continuously Rejects Printheads

- 1 Clean the flex contacts on the Printhead and in the Carriage Assembly using the Carriage Interconnect Wiper (Refer to Chapter 3) and try again.
- 2 If ALL the Printheads are rejected (the status message on the Front Panel does NOT show "OK" for all the Printheads) then perform the Electronic Systems Test ⇒ Page 4-5.

Cover Sensors are not Working

- 1 Check if the faulty sensor is installed correctly.
- 2 Check if the cable for the faulty sensor is connected correctly.
- 3 Replace the faulty Sensor.

The Line Sensor has Problems Detecting Media

- 1 Check the type of media that is being used since the Line sensor may have problems detecting transparent media or some types of Non-HP media. Try loading white HP media in to the Printer and check if the Line sensor detects it.
- 2 Excessive ink deposits on the Platen surface can fool the sensor by reflecting the light. Clean the Platen.
- 3 The Line Sensor is not calibrated correctly. Perform the Line Sensor calibration ⇒ Page 5-9.
- 4 The Line Sensor is damaged or faulty. Replace the Carriage Assembly ⇒ Page 8-44.

Troubleshooting Media Jams/Printhead Crashes

NOTE

If using HP Coated Media when problem occurred, please also refer to *Page 1-10, Printhead Crashes/Smears on High Density Prints Using Coated Media.*

The failure modes "media jam" and "head crash" are grouped together because in many cases a media jam causes the media to lift up into the carriage path and cause a head crash, thus causing many media jam failures to be reported as head crashes.

- 1 Did the media jam occur when loading media?
 - If the client has had media jams, it is common for pieces of media to get stuck in the media path. Clear the media path.

NOTE

When clearing a media jam, sometimes media is stuck in the paper path. To clear this, you must lift the media load handles and insert thicker media into the paper path to push out the media that is still stuck there.

- 2 Is the customer using non-HP media?
 - The use of non-HP media can easily be the cause of media jams and head crashes (especially head crashes because HP media is specially formulated to avoid cockle, one of the primary causes of head crashes). If the media is not HP approved, advise the customer to use HP media and check to see if the problem is now solved.
- 3 The Carriage is at the incorrect height in relation to the Center Platen. Adjust the carriage to the correct height ⇒ Page 5-24 and try to load the media again.
- 4 Check that the Vacuum Fan works correctly - **Refer to *Page 1-9, Problems with the Vacuum Fan.***

Troubleshooting Shutdowns

If a shutdown occurs, you will get the message "Switch Power Off" followed by:

- Check Printhead Cleaner Path.
- Check Paper Path.
- Check Printhead Path (followed by (1), (2) or (3)).

A shutdown in each path will require different steps to resolve the

problem as explained as follows.

WARNING

In each case, make sure that you power OFF the printer before attempting any procedures to resolve the problem.

Printhead Cleaner Path

- 1 Open the right door of the printer and check for any visible obstacles restricting the movement of the Service Station. Manually move the Service Station, checking for smooth and free movement.

Paper Path

- 1 Open the Window and check for any visible obstacles restricting the movement of the Drive Roller. If there is a wrinkled mass of media inside the paper path, lift the Pinch wheels (using the Media Load Handles) and clear the obstruction. If you cannot reach the media, remove the Electronics Module (⇒ Page 8-25) and the Roller Guide (⇒ Page 8-66) from the Rear of the Printer to gain better access.
- 2 If this shutdown happens at the end of a Roll of Media, it could be because the media is stuck firmly to the Roll. Lift the Pinch wheels (using the Media Load Handles) and pull the media clear.
- 3 Replace media spindle if broken.
- 4 Replace the Paper-Axis Motor ⇒ Page 8-12.

Printhead Path

When a shutdown occurs in the Printhead path, you will get the message "Switch Power Off / Check Printhead Path (*). The (*) will be a number, which will give an indication on where the failure occurred:

PWM Shutdown (1) and Energy Shutdown (3)

- 1 Clean Slider Rods and Apply Oil along the complete axis of the Slider Rods. After applying the Oil, perform the Scan-Axis Test ⇒ Page 4-17 and check that the values are within the given limits.
- 2 Replace the Scan-Axis Motor ⇒ Page 8-33.

Velocity Shutdown (2)

- 1 Open the Window and check for any visible obstacles restricting the movement of the Carriage Assembly. Try and move the Carriage Assembly manually, checking for smooth and free movement.
- 2 Check that the Encoder Strip is clean. If necessary, clean Encoder Strip using a damp cloth.

Problems with the Vacuum Fan

If you have problems loading either Roll or Sheet Media, then there could be a problem with the Vacuum Fan. To verify if there really is a problem with the Vacuum Fan, try the following:

- 1 With the Printer ON, open the Window of the Printer and place a sheet of HP High Gloss Photo Paper (must be D-Size), aligned with the blue lines on the Center Platen. If the Vacuum Fan holds the sheet in place, and then loads it correctly, then the Vacuum Fan functions correctly. If the Vacuum Fan does not hold the sheet in place (no suction), then try the following:
 - Check that the holes in the Center Platen are NOT blocked.
 - Check that the Vacuum Fan is installed correctly.
 - Replace the Vacuum Fan ⇒ Page 8-11.
- 2 If the Vacuum Fan held the sheet in place, but couldn't correctly load it, then there could be a problem with the Overdrive. In this case, replace the Platen Assembly ⇒ Page 8-63.

Vacuum suction much lower at high altitudes

At altitudes above 3,000 meters, the vacuum force holding down the media will be lower, therefore the media will not be held in place properly causing:

- Ink Smearing on the Media.
- Printhead crashes against the Media.
- Cut Sheet loading problems (high probability).
- Roll Media loading problems (low probability).

PRINTER LIMITATION - NO SOLUTION AVAILABLE.

Bin marks on prints done on HP High Gloss media

Prints done on HP High Gloss media are sensitive to scratches when they fall into the media bin. To solve the problem, try the following:

- Advise the customer to install the Media Bin cover, that was included with the Printer, to avoid this problem.
- If possible, advise the customer to hold the prints and prevent them from falling in to the bin.

Printhead Crashes/Smears on High Density Prints Using Coated Media

High density prints can cause cockle mainly on HP Coated Media. This causes two main problems:

1. Cockling in the borders - Because the printer places too much ink on the Coated Media, the borders of the print become raised, causing the Printhead to crash against the media. To solve the problem, try the following:
 - Check in the Front Panel if **Ink Limiting** is ON or OFF. If Ink Limiting is OFF, turn it ON.
 - Change the paper margins to 15mm, either in the Front Panel or in the Driver. If the customer is printing PostScript images, send them a PPD file containing the extended margins of 15mm.
2. Cockling within the print - If the Printer places too much ink within the print, the media starts to ripple, causing the Printhead to smear against the media. To solve the problem, try the following:
 - Check in the Front Panel if **Ink Limiting** is ON or OFF. If Ink Limiting is OFF, turn it ON.
 - Never use HP Coated Media for High Density prints. As a substitute use HP Heavy Coated Media.

Color changes when stacking prints done on HP High Gloss Media

Color differences can be seen between the covered and uncovered part of a print done on HP High Gloss Media. This is because the part of the print exposed to the air is always lighter than the covered one. The ink on the covered part of the print cannot evaporate therefore the ink continues to diffuse creating larger ink dots. To solve the problem, try the following:

- Allow the print to absolute drying completion before stacking. Depending on the ink percentage, this can take from 10 minutes up to 3 hours.
- Creating dryer environmental conditions helps reduce the problem. To find the environmental conditions, print the Service Configuration Print (*Printer Setup Menu / Utilities / Test prints / Service config*)

HP-GL/2 color differences in different HP DesignJet Printers

Color differences between one image printed on the HP DesignJet 1000 Series and the rest of the DesignJet platforms are due to the different chemistry of the 1000 series inks compared with the rest of the inks for other printers. This color variability among different HP DesignJet Series Printers has been always present. To solve the problem, try the following:

- Perform the color calibration from the driver at the time of printing. However, that calibration is not very accurate but it may help in the most severe cases.
- Some applications have color controls for the user to modify the image in order to obtain the desired colors.
- Printing with PostScript reduces the problem significantly.
- Avoid very long exposures to extreme environmental conditions after printing with glossy media (more than 12 hours at 80% humidity may result in severe changes in color).

Scratches on prints done on NTP, Vellum and HP High Gloss media

Normally at the end of a roll, the curl on the media is high and the printed area can touch the media load handles or the media roll, transferring ink to the "still-not-printed" media or damaging the actual print. This problem mainly affects Natural Tracing Paper (NTP), Vellum and HP High Gloss Media. To solve the problem, try the following:

- Increase the Dry Time using the Front Panel (Refer to the User's Guide - **Chapter 3 Working with Paper**).
- Install a new roll of media.

Banding at variable extreme environmental conditions

Since the Accuracy Calibration has been done at normal environmental conditions, printing in extreme environmental conditions will cause banding because the advance of the Drive Roller does not correspond to the same conditions that the calibration was done in. To solve the problem, try the following:

- Perform the Accuracy Calibration in the new environmental conditions (Refer to the User's Guide - **Chapter 8 Reconfiguring your Printer**).

Banding due to Ink Cartridge replacement while printing

A user has removed the Ink Cartridge while the printer was printing, which has caused the printer to stop. If the user does not replace the Ink Cartridge immediately, when the printer starts to print again, a band will appear in the position where the printing restarted. This is because the wet ink interacts with the dried ink on the media causing the band to appear. To solve the problem, try the following:

- Do NOT remove the Ink Cartridge while the Printer is Printing. Only replace/remove Ink Cartridges in between Prints.
- If the Ink Cartridge was replaced due to the "Empty" status on the Front Panel, then advise the customer to replace the Ink Cartridge when the "Very Low" status is showing on the Front Panel.

Long term bleed and hue shift on HP High Gloss media

Under high humidity conditions (approx. >65%) the water trapped in the air can easily be absorbed by the highly hydrophilic media coating polymers. That allows the dye to migrate through the coating and causes bleeding. This problem is especially noticeable with the colors that require Magenta. To solve the problem, try the following:

- Reduce the level of humidity (<65%) that the Printer is working in. To find the humidity level, print the Service Configuration Print (*Printer Setup Menu / Utilities / Test prints / Service config*).

Lower image gloss directly after printing on HP High Gloss Photo Paper

Lower gloss appearance of the print when the media is drying which gradually disappears to get the final gloss level (between 10 and 60 minutes depending on the ink density). Try the following:

- Wait at least 60 minutes to achieve the high gloss appearance.

34" Rice Paper not supported

Roll length is 34" (Non-standard) and the pinch wheels can't control edge of media causing ink smears and Printhead crashes in middle of prints with or without area fills.

PRINTER LIMITATION - NO SOLUTION AVAILABLE.

Cut Sheet rice paper loading failure

Thin rice paper is sucked into the Center Platen grooves and Linear Blade Ridge. This implies that the friction between the Center Platen and the rice paper becomes higher than between the Overdrive wheels and the paper. This effect make it almost impossible to load the rice paper correctly because the Vacuum is too high.

PRINTER LIMITATION - NO SOLUTION AVAILABLE.

Worm marks on HP Coated media with light area fills

Light bands (S-shaped) in Paper axis direction where light area fills are printed, causing unacceptable Image Quality defect.

- Print the Service Configuration Print (⇒ Page 1-19) and check if the level of Humidity is very low (below 30%). Increasing humidity may help in reducing the severity of the problem.

NOTE

The media is causing the problem and NOT the Printer. Do not attempt to try and replace Printer parts to solve this problem.

Solving Media-Handling Problems

The Front Panel Keeps Indicating that Media Is Misaligned or Incorrectly Positioned

Roll media

- The roll may be loaded the wrong way. The paper should load over the roll toward you.
- The paper may be loaded at an angle. The right-hand edge must be parallel to the white line on the paper entry roller.

WARNING

Ensure that the paper is wrapped tightly on the roll. This is a very important step to remember because if this is not done, the media may be loaded at an angle, causing the media to be rejected.

- Perform the manual alignment procedure (Refer to the User's Guide).
- Check that the paper is correctly loaded onto the spindle.

Sheet media

- It must be loaded with the right-hand edge against the blue perforated line on the printer.
- The media may be crumpled or warped or may have irregular edges.
- If you are using hand-cut media, the edges may not form a right-angle or they may be rough. Do not use hand-cut media. Use only purchased sheet media.
- If the media you are trying to load is very slippery, hold the media with both hands, and gently push the media into the printer until it buckles upwards in the middle, this will help the printer to load it.
- If the overdrive is covered in dust, it will have problems picking up the sheet media during the load process. Clean the Overdrive using the Overdrive Cleaning Service Utility ⇒ Page 4-37.

How to Navigate through the Front-Panel Menu

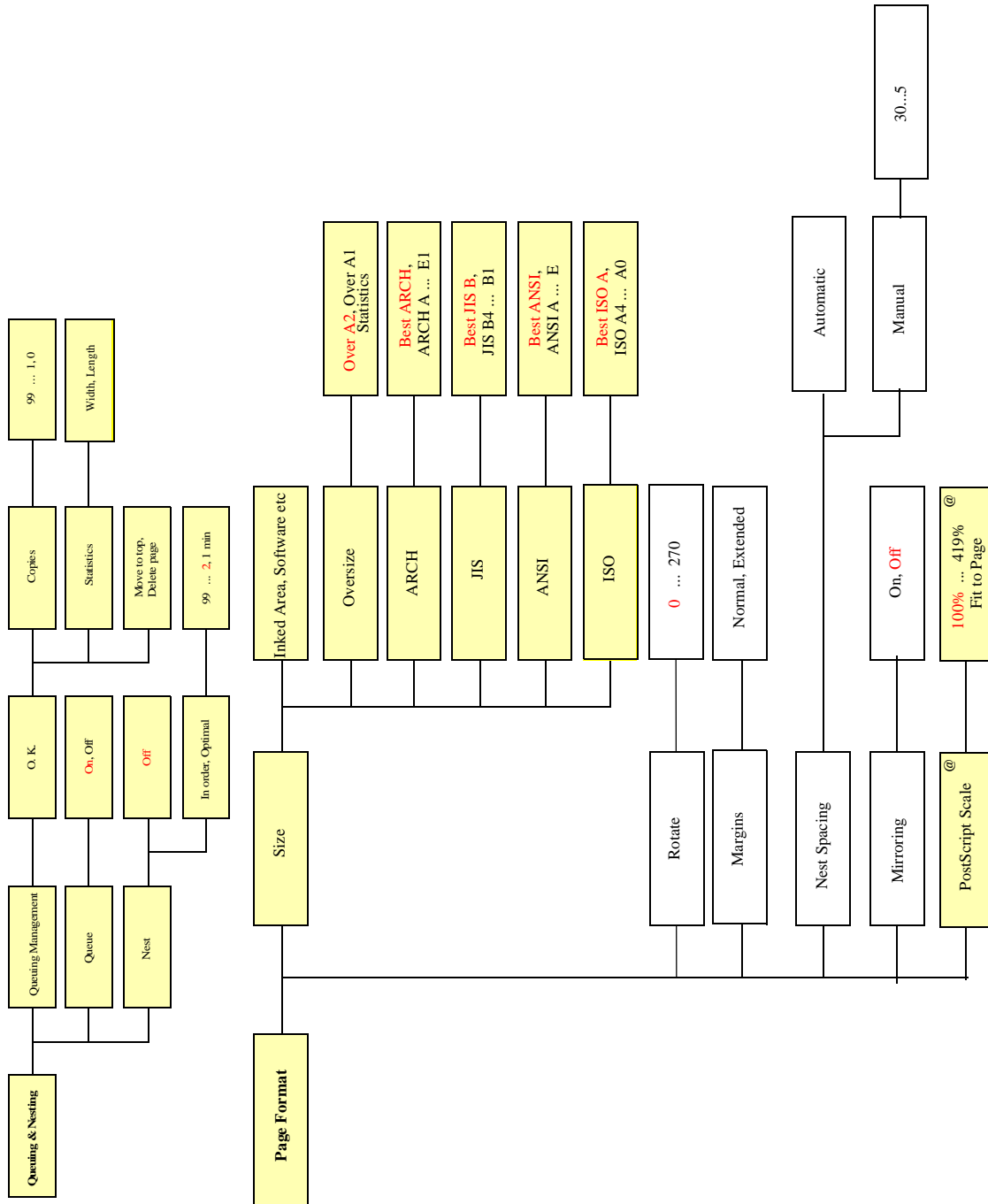

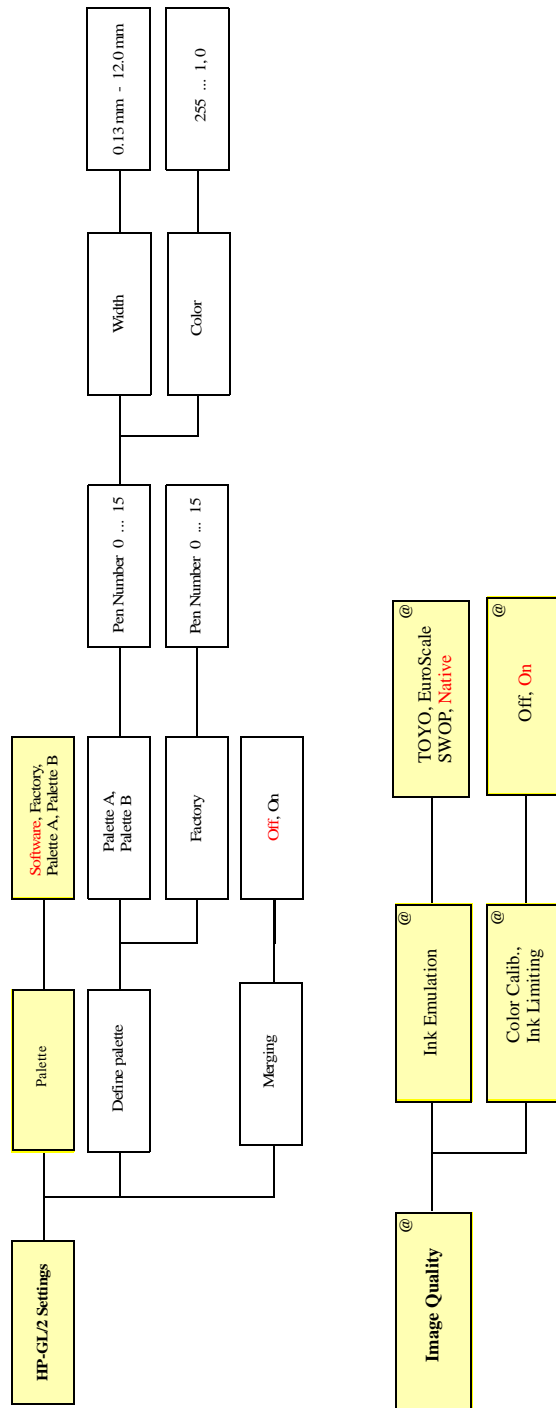

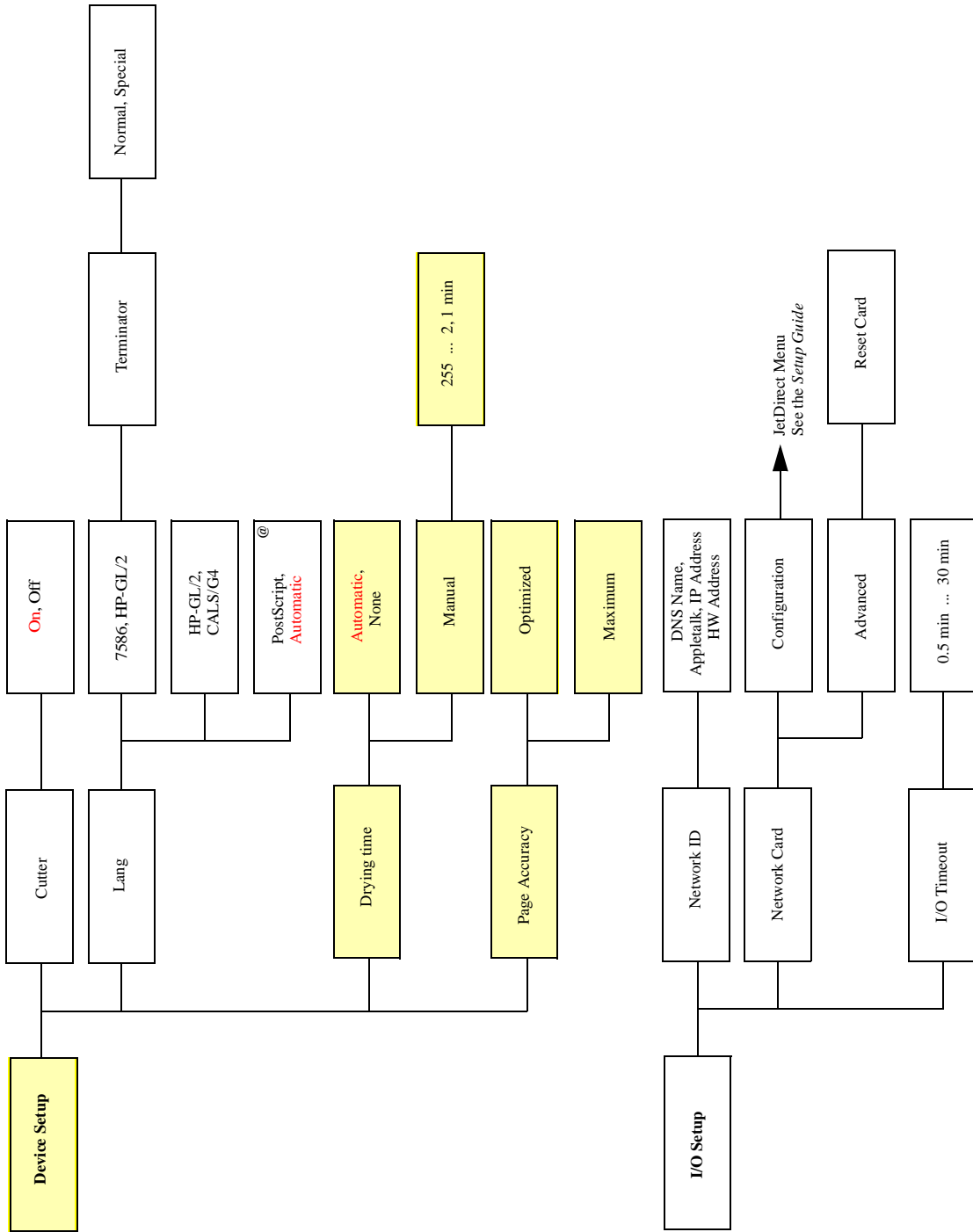

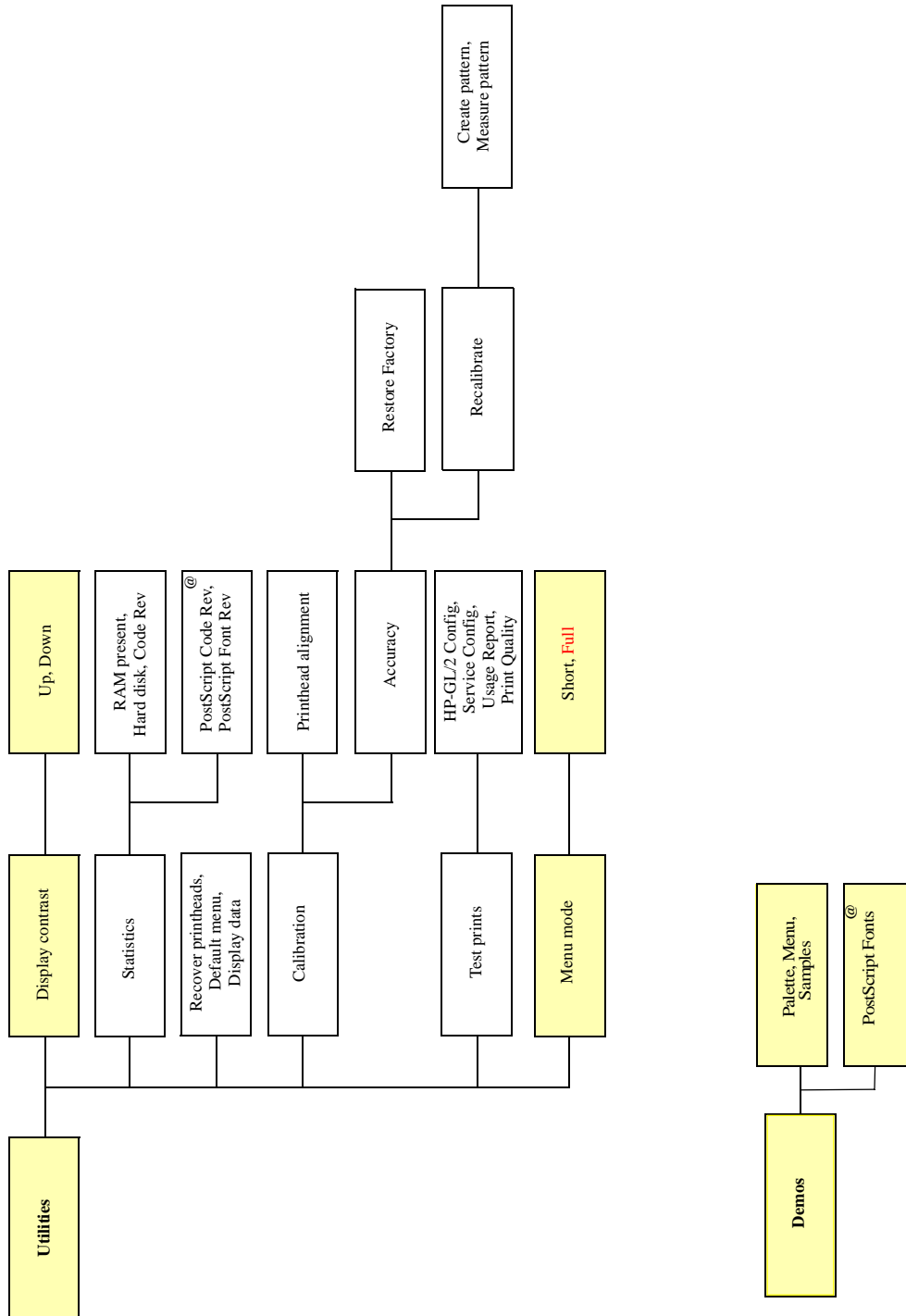

Service Configuration Print

The Service Configuration Print is a useful tool for troubleshooting the Printer. The Service Configuration Print contains the following information about the Printer:

- General Configuration
- Printhead Info.
- Cartridge Info.
- Operating Conditions.
- Calibrations.
- Maintenance.
- IIO Configuration.

How to Print the Service Configuration Print

- 1 Load media (Roll media or at least an A4 Sheet) into the Printer.
- 2 Once the message "Ready" is displayed on the front-panel, scroll to the "Printer Setup Options" icon and press the **Enter** key.

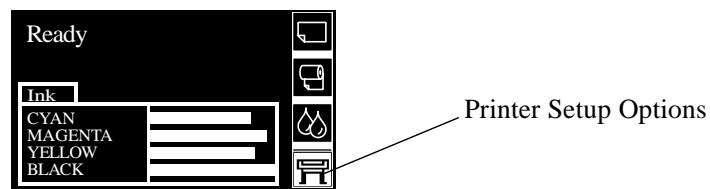

- 3 Once inside the "Printer Setup Options" menu, use the **Arrow** keys to scroll to the "Utilities" menu display and press the **Enter** key.

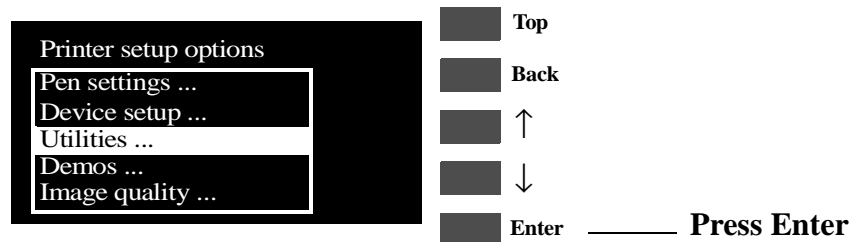

- 4 Once inside the "Utilities" menu, use the **Arrow** keys to scroll to the "Test Prints" menu display and press the **Enter** key.

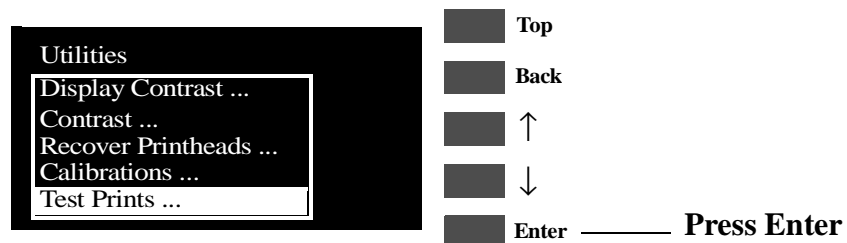

- 5 Use the **Arrow** keys to scroll to "Service Config." and press the **Enter** key to print the Service Configuration Print.

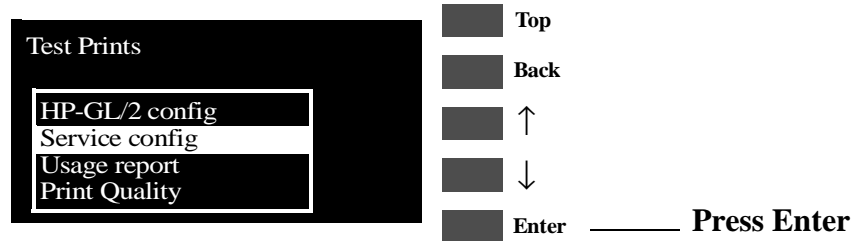

How to Use the Service Configuration Print

The Service Configuration Print is divided into 7 different areas where you can find information to troubleshoot the Printer.

- **General Configuration** - In this area you can find information regarding the general configuration of the Printer, for example, the firmware version, amount of memory installed or the capacity of the Hard Disk Drive.
- **Printhead Info** - In this area you can find all the information regarding the Printheads, for example, the part number, the manufacturing date or the number of times a certain Printhead has been inserted in the carriage. This information is useful for troubleshooting Printhead problems and even knowing if the Printheads have been used with Non-HP Cartridges.
- **Cartridge Info** - In this area you can find all the information regarding the Cartridges, for example, the part number, the manufacturing date or the ink level. This area also shows you if the customer is using Non-HP Cartridges.
- **Operating Conditions** - In this area you can find the level of humidity and the temperature that the Printer is working in.
- **Calibrations** - In this area you can find information on certain calibrations that have been performed on the Printer. It will also tell you if a required calibration was performed or not.
- **Maintenance** - In this area you can find information relating to maintenance, for example, the number times the Printer has been powered ON, the number of Carriage cycles or the last System Error Code that was triggered.
- **IIO Configuration** - In this area you can find information on the configuration of the JetDirect Card.

System Error Codes

2

System Error Codes	2-2
0000D8 XXXXXXXX (Non-Continuable)	2-3
01002D (Non-Continuable)	2-3
010020 (Non-Continuable)	2-3
010021 (Non-Continuable)	2-4
010023 (Non-Continuable)	2-4
010040	2-5
010041	2-5
010042	2-6
010050 XXXXXXXX (Non-Continuable)	2-6
01009X (Continuable)	2-7
02xxxx (Non-Continuable)	2-7
04Cxxx	2-8
048xxx	2-8
060301	2-9
060305 0000000X	2-9
060309	2-10
06030A (Continuable)	2-10
06030B	2-11
070100 XXXXXXXX (Non-Continuable)	2-11
080001 (Non-Continuable)	2-12
09xxxx (Non-Continuable)	2-12
0A0000	2-13
0A0010	2-13
0A0020	2-14
0A0030	2-14
0A0040	2-14
0A0050 (Non-Continuable)	2-15
0A0060 (Non-Continuable)	2-15
0A0070 (Continuable)	2-16
0C0030	2-16
0C0032 (Continuable)	2-17
0C1000	2-17
0C1001	2-17
System Error Codes During Initialization	2-18

System Error Codes

Introduction

System error codes are hexa-decimal based numbers generally caused by internal system errors. The following pages contain a list of system error codes and their respective descriptions and recommended corrective actions. Only try one recommended action at a time and check if the error code has disappeared.

If you have an error code which is not documented in this Service Manual or you have an error which you cannot resolve, then report the error to the HP Response Center or the nearest HP Support Office. When reporting the error, have the following information ready:

- Model and Serial Number of the printer.
- Which firmware revision the printer is using (See Note below). Check firmware in *Utilities / Statistics / Code rev.*
- The complete error number (See Note below).
- The Service Configuration Print ⇒ Page 1-19.
- The Current configuration sheet.
- Which software application the customer is using (name, version, etc.).

NOTE

When reporting the System Error Code, make sure that you supply the full Error Code (including the last 8 numbers where applicable) and the firmware version. Without this information, HP Support Personnel cannot help you.

Continuable and Non-Continuable Error Codes

Some of the Error Codes are continuable, which means you can press **Enter** on the front-panel and continue working with the Printer. Non-Continuable Error Codes do not allow you to continue working with the Printer, in this case power the Printer OFF and ON again and see if the System Error disappears. If the Error Code reappears, then the Printer requires an on-site visit in order to resolve the problem.

NOTE

Even though the customer can continue working with a Continuable Error Code, an on-site visit should still be planned to troubleshoot the problem.

System Error: 0000D8 XXXXXXXX (**Non-Continuable**)

Problem Description: External Library Error.

Corrective Action: Refer to System Error Code 070100.

System Error: 01002D (**Non-Continuable**)

Problem Description: The Main PCA cannot communicate with the Carriage.

Corrective Action: Perform the Electronic Systems Test ⇒ Page 4-5.

System Error: 010020 (**Non-Continuable**)

Problem Description: Firmware DIMM Test failure.

Corrective Action: Try the following:

- Switch the Power OFF from the back of the Printer and disconnect the Power cord. Reseat the Firmware DIMM, reconnect the power cord and power On the Printer.
- If the Error Code appears again, switch the Power OFF from the back of the Printer, disconnect the power cord and Replace the Firmware DIMM. Reconnect the power cord and power On the Printer and check if the Error Code has been resolved.
- If the System Error continues, replace the Electronics Module ⇒ Page 8-25.

WARNING

Only replace one component at a time and check if the error has gone before replacing another component. Using this procedure you will be able to determine exactly which component failed.

System Error: 010021 (**Non-Continuable**)

Problem Description: Memory DRAM DIMM Test failure.

Corrective Action: Try the following:

- Switch the Power OFF from the back of the Printer and disconnect the Power cord. Reseat the DRAM DIMMs (Memory Modules), reconnect the power cord and power On the Printer.
- If the Error Code appears again, switch the Power OFF, disconnect the power cord and Replace the Flash DIMMs (Memory Modules). Reconnect the power cord and power On the Printer and check if the Error Code has been resolved.
- If the Error Code continues, replace the Electronics Module ⇒ Page 8-25.

WARNING

Only replace one component at a time and check if the error has gone before replacing another component. Using this procedure you will be able to determine exactly which component failed.

System Error: 010023 (**Non-Continuable**)

Problem Description: EEROM Test failure.

Corrective Action: Try the following:

- Clear the EEROM (⇒ Page 4-38) and turn the Printer OFF and ON again from the back of the Printer. If after clearing the EEROM, the Error Code disappears, make sure you perform the Calibrations Backup ⇒ Page 5-19.

NOTE

Make sure that you select "Electronics Module Replaced" when performing the Calibrations Backup.

- If the Error Code continues, replace the Electronics Module ⇒ Page 8-25.

System Error:	010040
Problem Description:	Error in Paper-axis Encoder quadrature.
Corrective Action:	Try the following: <ul style="list-style-type: none">■ Check that the Paper-Axis Motor cable is NOT broken or damaged.■ Check that the Paper-Axis Motor cable is correctly connected.■ Replace the Paper-Axis Motor ⇒ Page 8-12.■ If the Error Code continues, replace the Electronics Module ⇒ Page 8-25.

WARNING Only replace one component at a time and check if the error has gone before replacing another component. Using this procedure you will be able to determine exactly which component failed.

System Error:	010041
Problem Description:	Error in Scan-axis Encoder quadrature.
Corrective Action:	Try the following: <ul style="list-style-type: none">■ Check that the Encoder Strip is NOT broken or damaged.■ Replace the Encoder Strip ⇒ Page 8-34.■ Replace the Carriage Assembly ⇒ Page 8-44.■ If the Error Code continues, replace the Electronics Module ⇒ Page 8-25.

WARNING Only replace one component at a time and check if the error has gone before replacing another component. Using this procedure you will be able to determine exactly which component failed.

System Error:	010042
Problem Description:	Error in Service Station-axis Encoder quadrature.
Corrective Action:	Try the following: <ul style="list-style-type: none">■ Check that the Service Station Encoder-Cable is NOT broken or damaged.■ Check that the Service Station Encoder-Cable is correctly connected.■ Replace the Service Station ⇒ Page 8-8.■ If the Error Code continues, replace the Electronics Module ⇒ Page 8-25.

WARNING Only replace one component at a time and check if the error has gone before replacing another component. Using this procedure you will be able to determine exactly which component failed.

System Error:	010050 XXXXXXXXX (Non-Continuable)
Problem Description:	PostScript Processing Error.
Corrective Action:	Power the Printer OFF and ON again to see if the System Error disappears. Try sending the print again. <p>If the Error Code reappears after sending the print again, then report the error to the HP response Center or the nearest HP Support Office, stating the following information.</p> <ul style="list-style-type: none">■ Model and Serial Number of the printer.■ Which firmware revision the printer is using (See Note below). Check firmware in <i>Utilities / Statistics / Code rev.</i>■ The complete error number (See Note below).■ The Service Configuration Print ⇒ Page 1-19.■ The Current configuration sheet.■ Which software application the customer is using (name, version, etc.).

NOTE When reporting the System Error Code, make sure that you supply the full Error Code (including the last 8 numbers where applicable) and the firmware version. Without this information, HP Support Personnel cannot help you.

System Error:	01009X (Continuable)
Problem Description:	Error in Paper-axis Motor Encoder
Corrective Action:	Try the following: <ul style="list-style-type: none">■ Check that the Paper-Axis Motor cable is NOT broken or damaged.■ Check that the Paper-Axis Motor cable is correctly connected.■ Replace the Paper-Axis Motor ⇒ Page 8-12.■ If the Error Code continues, replace the Electronics Module ⇒ Page 8-25.

WARNING Only replace one component at a time and check if the error has gone before replacing another component. Using this procedure you will be able to determine exactly which component failed.

System Error:	02xxxx (Non-Continuable)
Problem Description:	PostScript/Firmware Error.
Corrective Action:	Power the Printer OFF and ON again to see if the System Error disappears. If the Error Code reappears, then report the error to the HP response Center or the nearest HP Support Office, stating the following information. <ul style="list-style-type: none">■ Model and Serial Number of the printer.■ Which firmware revision the printer is using (See Note below). Check firmware in <i>Utilities / Statistics / Code rev.</i>■ The complete error number (See Note below).■ The Service Configuration Print ⇒ Page 1-19.■ The Current configuration sheet.■ Which software application the customer is using (name, version, etc.).

NOTE When reporting the System Error Code, make sure that you supply the full Error Code (including the last 8 numbers where applicable) and the firmware version. Without this information, HP Support Personnel cannot help you.

System Error:	04Cxxx
Problem Description:	EIO Accessories (EIO Card/Hard Disk Drive) Error.
Corrective Action:	Try the following: <ul style="list-style-type: none">■ Press ENTER and switch the printer OFF. Remove the Hard Disk Drive (if installed) and make sure that the EIO card is installed correctly by pushing it firmly inwards and checking that the two installation screws are completely tightened. Switch the printer ON again. If this error code continues to appear then replace the EIO card.■ If this Error Code disappeared after removing the Hard Disk Drive, then switch the Printer OFF and reinstall the Hard Disk Drive, making sure that the two installation screws are completely tightened. Switch the Printer ON again. If this Error Code reappears, then the Hard Disk Drive could be faulty. Replace the Hard Disk Drive.■ If this system error continues to appear after replacing the EIO card or the Hard Disk Drive, then replace the Electronics Module ⇒ Page 8-25.

System Error:	048xxx
Problem Description:	The EIO card is from a third party vendor and may not be fully compliant with the IIO Protocol specification 2.0 OR the EIO Card firmware is not updated.
Corrective Action:	Try the following: <ul style="list-style-type: none">■ Check with the third party vendor. If the EIO card is not compliant with the IIO Protocol specification 2.0 then you must install a new EIO card which is compliant.■ Update the EIO Card firmware.

System Error:	060301
Problem Description:	One of the Printheads has an Internal Electrical Problem.
Corrective Action:	Try the following: <ul style="list-style-type: none">■ Remove all the Printheads and clean the flex contacts on the Printheads and in the Carriage Assembly (Refer to Chapter 2).■ Perform the Electronic Systems Test ⇒ Page 4-5.■ Make sure that the Trailing Cable is connected correctly.■ Replace the Trailing Cable ⇒ Page 8-39.■ Replace the Carriage Assembly ⇒ Page 8-44.■ If the error code continues, replace the Electronics Module ⇒ Page 8-25.
WARNING	Only replace one component at a time and check if the error has gone before replacing another component. Using this procedure you will be able to determine exactly which component failed.

System Error:	060305 0000000X
Problem Description:	Thermal Shutdown error (one of the Printheads has gone above the maximum Temperature).
	Error Data: <ul style="list-style-type: none">00000000 → Cyan Printhead Failed.00000001 → Magenta Printhead Failed.00000002 → Yellow Printhead Failed.00000003 → Black Printhead Failed.
Corrective Action:	Try the following: <ul style="list-style-type: none">■ Replace the failing Printhead.■ If the problem remains after replacing the failing Printhead then check if the customer is using a 3rd Party RIP. If a 3rd Party RIP is being used, check the Print Settings in the RIP or try printing one of the Internal Demo Prints to see if the problem is solved without the RIP.

System Error: 060309

Problem Description: Problem with setting the Voltage of the Printheads.

Corrective Action: Try the following:

- Remove ALL the Printheads and clean the flex contacts on the Printheads and in the Carriage Assembly (Refer to Chapter 2).
- Perform the Electronic Systems Test ⇒ Page 4-5.
- Replace ALL the Printheads.
- Replace the Trailing Cable ⇒ Page 8-39.
- Replace the Carriage Assembly ⇒ Page 8-44.
- If the Error Code continues, replace the Electronics Module ⇒ Page 8-25.

WARNING

Only replace one component at a time and check if the error has gone before replacing another component. Using this procedure you will be able to determine exactly which component failed.

System Error: 06030A (**Continuable**)

Problem Description: Error in finding the Mark Encoder.

Corrective Action: Try the following:

- Clean the Mark Encoder if necessary (use the Overdrive Cleaning Utility to position the Mark Encoder ⇒ Page 4-37).
- Clean the Line Sensor (located on the Carriage Assembly).
- Perform the Line Sensor Calibration ⇒ Page 5-9.
- Perform the Mark Encoder Calibration ⇒ Page 5-13.
- Replace the Trailing Cable ⇒ Page 8-39.
- Replace the Carriage Assembly ⇒ Page 8-44.
- If the Error Code continues, replace the Electronics Module ⇒ Page 8-25.

WARNING

Only replace one component at a time and check if the error has gone before replacing another component. Using this procedure you will be able to determine exactly which component failed.

System Error:	06030B
Problem Description:	The Ambient Temperature measured is out of the normal range.
Corrective Action:	Try the following: <ul style="list-style-type: none">■ Make sure that the Ambient temperature is within the allowed range (between 0 and 55 Degrees Centigrade).■ Replace the Electronics Module ⇒ Page 8-25.

System Error:	070100 XXXXXXXX (Non-Continuable)
Problem Description:	Firmware Error.
Corrective Action:	Power the Printer OFF and ON again to see if the System Error disappears. If the Error Code reappears, then report the error to the HP response Center or the nearest HP Support Office, stating the following information. <ul style="list-style-type: none">■ Model and Serial Number of the printer.■ Which firmware revision the printer is using (See Note below). Check firmware in <i>Utilities / Statistics / Code rev.</i>■ The complete error number (See Note below).■ The Service Configuration Print ⇒ Page 1-19.■ The Current configuration sheet.■ Which software application the customer is using (name, version, etc.).

NOTE	When reporting the System Error Code, make sure that you supply the full Error Code (including the last 8 numbers where applicable) and the firmware version. Without this information, HP Support Personnel cannot help you.
-------------	--

System Error: 080001 (**Non-Continuable**)
Problem Description: PostScript Error.
Corrective Action: Refer to System Error Code 070100.

System Error: 09xxxx (**Non-Continuable**)
Problem Description: EIO Accessories (EIO Card/Hard Disk Drive) Error.

Corrective Action: Try the following:

- Switch the Printer OFF and ON again and wait for the initialization.
- If the Error code continues to appear, switch the Printer OFF. Remove the EIO Card (if installed) and make sure that the Hard Disk Drive is installed correctly by pushing it firmly inwards and checking that the two installation screws are completely tightened. Switch the Printer ON again. If the error codes 09Axxx or 09Bxxx appear then replace the Hard Disk Drive.
- If the Error Code disappeared after removing the EIO Card, then switch the Printer OFF and reinstall the EIO Card, making sure that the two installation screws are completely tightened. Switch the Printer ON again. If the Error Code reappears, then the EIO Card could be faulty. Replace the EIO Card.
- If Error Code 09Cxxx appears after initialization, then replace the Electronics Module ⇒ Page 8-25.
- Once the Error Code has been solved, print an Internal Demo Print to make sure that the Hard Disk Drive is functioning correctly. If the Error Code reappears, then use the above information to troubleshoot the problem.

System Error:	0A0000
Problem Description:	The Air Pressure is below the minimum requirement.
Corrective Action:	Try the following: <ul style="list-style-type: none">■ Check all the cables of the APS and make sure they are correctly connected and are NOT damaged.■ Check all the tubes of the APS and Tubes System and make sure they are correctly connected and are NOT pinched or damaged.■ Check that the Air Tube from the APS is correctly connected to the Tubes System.■ Faulty APS Sensor, APS Valve or APS Pump. Replace the complete APS ⇒ Page 8-20.■ Replace ONE Ink Cartridge at a time, checking if the error code disappears.

WARNING

Only replace one component at a time and check if the error has gone before replacing another component. Using this procedure you will be able to determine exactly which component failed.

System Error:	0A0010
Problem Description:	Problem in Pressurizing the Air System.
Corrective Action:	Try the following: <ul style="list-style-type: none">■ Replace ONE Ink Cartridge at a time, checking if the error code disappears.■ Check all the cables of the APS and make sure they are correctly connected and are NOT damaged.■ Check all the tubes of the APS and Tubes System and make sure they are correctly connected and are NOT pinched or damaged.■ Faulty APS Sensor, APS Valve or APS Pump. Replace the complete APS ⇒ Page 8-20.

WARNING

Only replace one component at a time and check if the error has gone before replacing another component. Using this procedure you will be able to determine exactly which component failed.

System Error: 0A0020

Problem Description: Error in Calibrating the APS Sensor.

Corrective Action: Try the following:

- Check all the cables of the APS and make sure they are correctly connected and are NOT damaged.
- Check all the tubes of the APS and Tubes System and make sure they are correctly connected and are NOT pinched or damaged.
- Faulty APS Sensor or APS Valve. Replace the complete APS ⇒ Page 8-20.

System Error: 0A0030

Problem Description: Problem in Depressurizing Air System.

Corrective Action: Try the following:

- Check the APS for any signs of Ink. Also inspect ALL Ink Cartridges for any signs of leaking (the bottom valve of the Ink Cartridge will contain ink).
- If there is Ink Leakage, replace ALL Ink Cartridges, the APS (⇒ Page 8-20) and the Tubes System (⇒ Page 8-53).

System Error: 0A0040

Problem Description: Ink Tubes Initialization Failure Due to Low Air Pressure.

Corrective Action: Try the following:

- Check all the cables of the APS and make sure they are correctly connected and are NOT damaged.
- Check all the tubes of the APS and Tubes System and make sure they are correctly connected and are NOT pinched or damaged.
- Replace ONE Ink Cartridge at a time, checking if the error code disappears.
- Faulty APS Sensor or APS Pump. Replace the complete APS ⇒ Page 8-20.

System Error:	0A0050 (Non-Continuable)
Problem Description:	The Printer has detected a leak in the Tubes System before the life of the System.
Corrective Action:	Try the following: <ul style="list-style-type: none">■ The leak detector could have been triggered due to condensation in the Printer. Power OFF the Printer and allow the Printer to dry for 15 minutes. Power ON the Printer and check if the error code has disappeared.■ If the Error Code reappears, replace the complete Tubes System (SRK) ⇒ Page 8-53.
WARNING	Only replace one component at a time and check if the error has gone before replacing another component. Using this procedure you will be able to determine exactly which component failed.

System Error:	0A0060 (Non-Continuable)
Problem Description:	The Printer has detected a leak in the Tubes System after the life of the System.
Corrective Action:	Try the following: <ul style="list-style-type: none">■ The leak detector could have been triggered due to condensation in the Printer. Power OFF the Printer and allow the Printer to dry for 15 minutes. Power ON the Printer and check if the error code has disappeared.■ If the error code reappears, replace the complete Tubes System (SRK) ⇒ Page 8-53.
WARNING	Only replace one component at a time and check if the error has gone before replacing another component. Using this procedure you will be able to determine exactly which component failed.

System Error: 0A0070 (**Continuable**)

Problem Description: The Backup EEROM contents stored in the Tubes System are not consistent with the ones required by the firmware.

Corrective Action: Try the following:

- Perform the Calibrations Backup ⇒ Page 5-19.

NOTE **Make sure that you select "Tubes Replaced" when performing the Calibrations Backup.**

System Error: 0C0030

Problem Description: Bad Drop Detector.

Corrective Action: Try the following:

- Check that the Drop Detector Cable is NOT broken or damaged.
- Check that the Drop Detector cable is correctly connected to the Service Station Cable.
- Remove the Drop Detector and make sure that there are no obstacles inside which are blocking the sensor.
- Replace the Drop Detector Assembly ⇒ Page 8-10.
- If the Error Code continues, replace the Electronics Module ⇒ Page 8-25.

WARNING **Only replace one component at a time and check if the error has gone before replacing another component. Using this procedure you will be able to determine exactly which component failed.**

System Error:	0C0032 (Continuable)
Problem Description:	Drop Detector not Calibrated for all Printheads.
Corrective Action:	Try the following: <ul style="list-style-type: none">■ Perform the Service Station Calibration ⇒ Page 5-11.■ Replace the Drop Detector Assembly ⇒ Page 8-10.■ If the Error Code continues, replace the Electronics Module ⇒ Page 8-25.
WARNING	Only replace one component at a time and check if the error has gone before replacing another component. Using this procedure you will be able to determine exactly which component failed.

System Error:	0C1000
Problem Description:	Primer not Calibrated.
Corrective Action:	Try the following: <ul style="list-style-type: none">■ Perform the Service Station Calibration ⇒ Page 5-11.■ Make sure that the Primer Arm is not damaged. If the Primer Arm is damaged, replace the Service Station ⇒ Page 8-8.■ Replace the Electronics Module ⇒ Page 8-25.

System Error:	0C1001
Problem Description:	Primer Shutdown Error.
Corrective Action:	Try the following: <ul style="list-style-type: none">■ Check that the Primer Stepper-Motor Cable is NOT broken or damaged and that the Primer arm moves freely from side to side.■ Replace the Service Station ⇒ Page 8-8.■ If the Error Code continues, replace the Electronics Module ⇒ Page 8-25.

WARNING	Only replace one component at a time and check if the error has gone before replacing another component. Using this procedure you will be able to determine exactly which component failed.
----------------	--

System Error Codes During Initialization

The following System Error Codes will only appear during the Initialization process when you power ON the Printer.

System Error: 0B0000

Problem Description: Bad Ambient Temperature measured.

Corrective Action: Try the following:

- Make sure that the Ambient temperature is within the allowed range (between 0 and 55 Degrees Centigrade).
- Replace the Electronics Module ⇒ Page 8-25.

System Error: 0B0001

Problem Description: Bad Humidity read.

Corrective Action: Replace the Electronics Module ⇒ Page 8-25.

System Error: 0B0002

Problem Description: Bad IDS pressure read.

Corrective Action: Try the following:

- Check that the cable from the Ink Supply Station (ISS) PCA to the Ink Supply Station is correctly connected.
- Check that the Air Pressurization System Sensor Cable is correctly connected and is NOT damaged.
- Check all the tubes of the APS and make sure they are NOT pinched or damaged.
- Faulty APS Sensor. Replace the complete APS ⇒ Page 8-20.
- If the error code continues, replace the Electronics Module ⇒ Page 8-25.

WARNING Only replace one component at a time and check if the error has gone before replacing another component. Using this procedure you will be able to determine exactly which component failed.

System Error: 0B0003
Problem Description: ADC0 Internal channels check Failure.
Corrective Action: Replace the Electronics Module ⇒ Page 8-25.

System Error: 0B0004
Problem Description: Unable to detect Pump.
Corrective Action: Try the following:

- Check that the cable from the Ink Supply Station (ISS) PCA to the Ink Supply Station is correctly connected.
- Faulty APS Pump. Replace the complete APS ⇒ Page 8-20.
- If the error code continues, replace the Electronics Module ⇒ Page 8-25.

WARNING Only replace one component at a time and check if the error has gone before replacing another component. Using this procedure you will be able to determine exactly which component failed.

System Error: 0B0005
Problem Description: Unable to detect Valve.
Corrective Action: Try the following:

- Check that the cable from the Ink Supply Station (ISS) PCA to the Ink Supply Station is correctly connected.
- Faulty APS Valve. Replace the complete APS ⇒ Page 8-20.
- If the error code continues, replace the Electronics Module ⇒ Page 8-25.

WARNING Only replace one component at a time and check if the error has gone before replacing another component. Using this procedure you will be able to determine exactly which component failed.

System Error:	0B0006
Problem Description:	The Trailing Cable has been incorrectly connected OR the fuse in the Electronics Module has been burned.
Corrective Action:	Turn the Printer OFF and disconnect the trailing cable. Check that the ends of the Trailing Cable are flat and are not damaged or bent. Reconnect the Trailing Cable correctly, making sure it is pushed in firmly (Refer to the instructions on Page 8-39). Power ON the Printer and check if the Error Code disappears. If the Error Code continues, replace the Electronics Module (Refer to the instructions on Page 8-25), making sure you take care when you reconnect the Trailing Cable.

WARNING PLEASE TAKE CARE WHEN CONNECTING THE TRAILING CABLE TO THE ELECTRONICS MODULE. INCORRECT INSTALLATION WILL BURN THE FUSE IN THE ELECTRONICS MODULE, CAUSING THE COMPLETE REPLACEMENT OF THE ELECTRONICS MODULE.

System Error:	0B0007
Problem Description:	Unable to detect Vacuum Fan.
Corrective Action:	Try the following: <ul style="list-style-type: none">■ Make sure that the Vacuum Fan is connected correctly to the Electronics Module.■ Turn the Printer OFF and disconnect the Vacuum Fan from the Electronics Module. Connect a New Vacuum Fan to the Electronics Module and power ON the Printer. If the New Vacuum Fan functions correctly without any Error Codes then remove the Old Vacuum Fan from the Printer and install the New one.■ If the New Vacuum Fan does not function correctly either, then replace the Electronics Module ⇒ Page 8-25.

System Error:	0B0008
Problem Description:	Unable to detect Cooling Fan.
Corrective Action:	Replace the Electronics Module ⇒ Page 8-25.

System Error:	0B0009
Problem Description:	Unable to detect Aerosol Fan (Included on the Right Cover).
Corrective Action:	Try the following: <ul style="list-style-type: none">■ Make sure that the Aerosol Fan is connected correctly to the Electronics Module.■ Turn the Printer OFF and disconnect the Aerosol Fan from the Electronics Module. Connect a New Aerosol Fan (comes with the new Right Cover) to the Electronics Module and power ON the Printer. If the New Aerosol Fan functions correctly without any Error Codes then remove the Old Aerosol Fan from the Printer and install the New one.■ If the New Aerosol Fan does not function correctly either, then replace the Electronics Module ⇒ Page 8-25.

System Error:	0B000A
Problem Description:	Primer Shutdown Error.
Corrective Action:	Try the following: <ul style="list-style-type: none">■ Check that the Primer Stepper-Motor Cable is NOT broken or damaged and that the Primer arm moves freely from side to side.■ Replace the Service Station ⇒ Page 8-8.■ If the Error Code continues, replace the Electronics Module ⇒ Page 8-25.

WARNING Only replace one component at a time and check if the error has gone before replacing another component. Using this procedure you will be able to determine exactly which component failed.

System Error:	0B000B
Problem Description:	Pump or Pressure Sensor not working.
Corrective Action:	Try the following: <ul style="list-style-type: none">■ Check that the cable from the Ink Supply Station (ISS) PCA to the Ink Supply Station is correctly connected.■ Check that the Air Pressurization System Sensor Cable is correctly connected and is NOT damaged.■ Check all the tubes of the APS and make sure they are NOT pinched or damaged.■ Faulty APS Sensor, APS Valve or APS Motor. Replace the complete APS ⇒ Page 8-20.■ If the error code continues, replace the Electronics Module ⇒ Page 8-25.

WARNING Only replace one component at a time and check if the error has gone before replacing another component. Using this procedure you will be able to determine exactly which component failed.

System Error:	0B000C
Problem Description:	Serial Device ADC test failure.
Corrective Action:	Replace the Electronics Module ⇒ Page 8-25.

System Error:	0B000D
Problem Description:	24 V source test failure.
Corrective Action:	Replace the Electronics Module ⇒ Page 8-25.

HP No.80 Ink Supplies Troubleshooting

3

What are HP No.80 Supplies?	3-2
Ink Cartridges	3-2
Printheads and Printhead Cleaners	3-2
Identifying the Components	3-3
General Information About HP No.80 Supplies	3-4
Some General Precautions When Handling HP No.80 Supplies	3-5
Priming the Ink System	3-6
When Should You Replace the HP No.80 Supplies?	3-6
The Front Panel Display	3-7
Obtaining Ink Cartridge Information	3-8
Obtaining Printhead Information	3-9
Ink Cartridge Status Messages	3-11
Ink Cartridge Status While Printing	3-11
Ink Cartridge Status While Replacing	3-12
Printhead Status Messages While Printing	3-13
Printhead Status Messages While Replacing	3-15
Summary of Solving HP No.80 Supplies Problems	3-17
Carriage Interconnect Wiper	3-18

What are HP No.80 Supplies?

For each of the four ink colors used in the printer, there are three separate components. The printhead and the printhead cleaner are supplied together, and the ink cartridge is supplied separately. All of these components are called the HP No.80 Supplies. They are coded with an HP No.80 selection number to identify the correct replacement supplies.



Ink Cartridges

The HP No.80 ink cartridges for the HP DesignJet 1050C and 1055CM printers require no maintenance or cleaning. As long as each ink cartridge is inserted correctly into its slot, the ink will flow to the printheads.

The front panel displays the status of the Ink Cartridge. With the front panel, detailed information can be checked on the Ink Cartridges.

Printheads and Printhead Cleaners

The HP No.80 printheads are extremely durable and do not need to be replaced every time an ink cartridge is replaced. They are independent of the ink cartridges and will continue giving excellent image quality results even if the ink cartridges are low on ink. See page 3-6, *When Should You Replace the HP No.80 Supplies?*

If you notice a decline in print quality such as lines or dots missing from text / graphics, go to page 6-13, *Troubleshooting Print Quality Problems*.

The HP No.80 printhead cleaners keep the printheads in good condition and they prevent them from being damaged when the printer is not active. They service the printhead, making sure it's always ready to be used.

Identifying the Components

The following illustration will help you identify the components of the HP No.80 supplies.

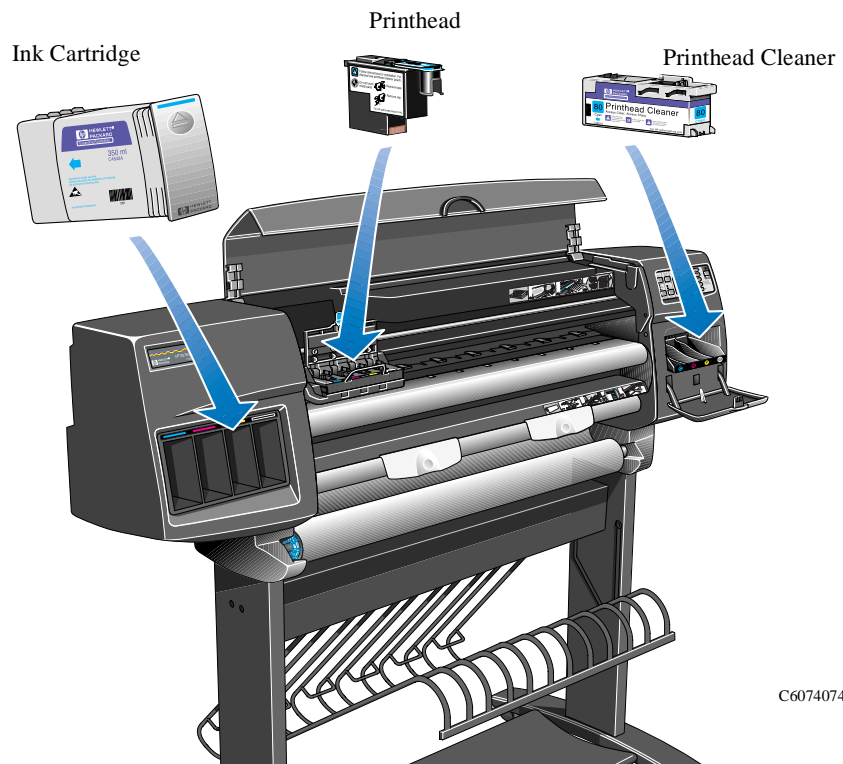

C6074074

General Information About HP No.80 Supplies

For optimum results from the printer and modular ink delivery system always follow these guidelines when handling the HP No.80 supplies:

- Always install the ink cartridges, printheads and printhead cleaners before the expire date, which is on the packaging.
- Install a new printhead cleaner every time you change a printhead.
- Allow the printer and printhead cleaners to automatically clean the printheads.
- Install ink cartridges, printheads and printhead cleaners in their color-coded slots.
- Follow the instructions on the front panel of the printer during installation.
- Avoid unnecessary removal of the ink cartridges and printheads.
- When turning off the printer always use the power Off button on the front panel. The printheads are then stored correctly which prevents them from drying out.
- The ink cartridges should never be removed while the printer is printing. They should only be removed when the printer is ready for you to replace them. The front panel will guide you through the removal and installation procedure. See page 3-6, *When Should You Replace the HP No.80 Supplies?*

Some General Precautions When Handling HP No.80 Supplies

CAUTION



Do not touch, wipe or attempt to clean the printhead nozzles. This can damage the printhead.

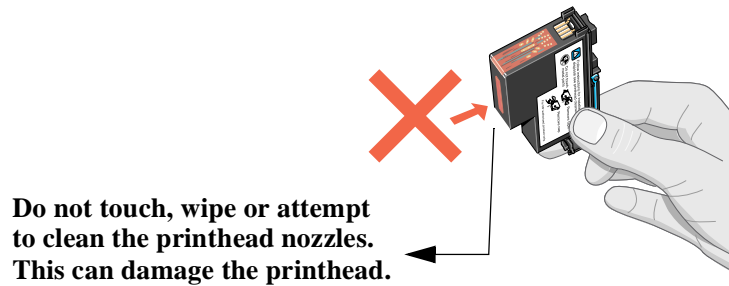

C6074297a

Handle the HP No.80 supplies with care. In particular the printhead, which is a high precision device and must be handled carefully.

- Do not touch the printhead nozzles.
- Do not put the printhead down on the nozzles.
- Do not be rough when handling the printheads. Always set them down gently.
- Do not drop the printheads.
- Proper handling will assure optimum performance throughout the printhead life.
- The printhead cleaner should always be handled and stored upright to avoid a potential spillage of ink.
- Do not touch the end of the ink cartridge which is inserted into the printer as there may be a small amount of ink on the connection.
- Avoid storing partially used ink cartridges on their ends.

Priming the Ink System

When the customer first receives the printer, it is supplied with a set of four setup printheads pre-installed in the printhead carriage. These setup printheads are used for the priming of the tubes in the modular ink delivery system. The customer must not remove the setup printheads from the carriage without following the procedures in the *Setup Guide*.

When the Printer is powered ON for the first time, the printer will automatically perform the priming process. Without the priming process, the customer will NOT be able to use the printer.

Why does the Printer require priming:

- The Tubes System is empty when the customer receives the Printer.
- The Tubes System has to be pressurized and filled with ink, ejecting any air bubbles.

CAUTION

If the Printing Printheads are installed in the carriage during the priming process, they will be rejected and the front panel will show the "Wrong Model" message.

When Should You Replace the HP No.80 Supplies?

When to change the HP No.80 supplies is mostly determined by you with guidance from the front panel. In conjunction with the messages displayed in the front panel and the message explanations in this chapter, you will be able to choose for yourself when is the right time to change the HP No.80 supplies.

The printer will also display the ink level and will tell you when the ink supply is low, very low or empty. This means you have constantly updated information about the HP No.80 supplies.

Printhead life is anticipated to be 700ml or twelve months in the printer, whichever occurs first, provided that the printhead is used under normal operating conditions (using HP Ink Cartridges only) and its “install before date” has not lapsed. However results vary depending on the print quality setting being used.

The Front Panel Display

The front panel display has a dedicated area to report the status of your HP No.80 supplies. There are two different screens:

- One screen displays information on the ink cartridges:

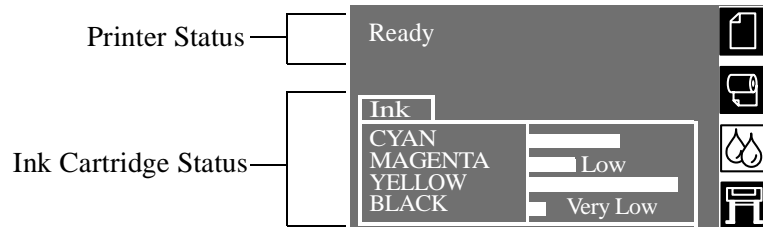

- The other screen displays information on the printheads and the printhead cleaners.

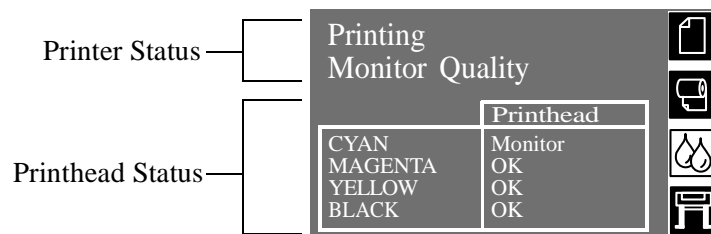

- During normal operation the front panel displays the ink levels, however if there is a printhead status message such as: **monitor** for example see page 3-13, *Printhead Status Messages While Printing*, the printhead message will take precedence. This is the case until you replace the printhead. If you need to see the ink levels when they are not being displayed you can use the ink systems menu to check them.

Obtaining Ink Cartridge Information

- 1 To get information on the ink cartridges press the **Top** key on the front panel to go to the main menu.



- 2 Press the \uparrow or \downarrow key until the front panel displays the ink system menu. Press **Enter**.



- 3 Press the \uparrow or \downarrow key until the front panel highlights “Ink Cartridge info”. Press the **Enter** key.

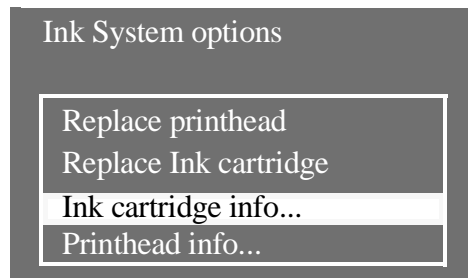

- 4 Press the \uparrow or \downarrow key until the front panel highlights the color that you want to see information on. Press the **Enter** key.

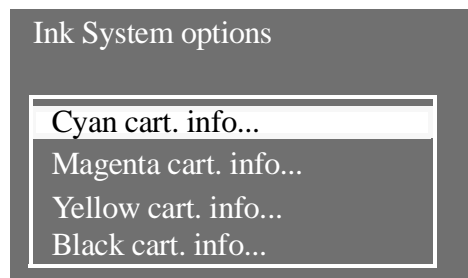

- The front panel displays information on the selected ink cartridge.

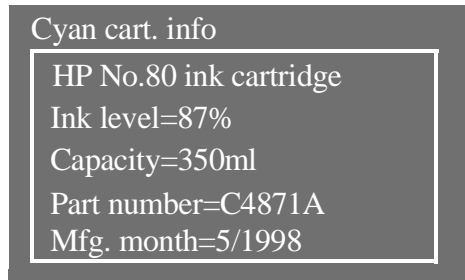

The information supplied is:

- The make of the ink cartridge (HP No.80 are recommended).
- The percentage of how much ink is remaining.
- Original capacity of the ink cartridge in milliliters.
- Re-order part number of the ink cartridge.
- The month and year that the ink cartridge was manufactured.

Obtaining Printhead Information

- To get information on your printheads, press the **Top** key on the front panel to go to the main menu.



- Press the \uparrow or \downarrow key until the front panel displays the ink system menu. Press **Enter**.

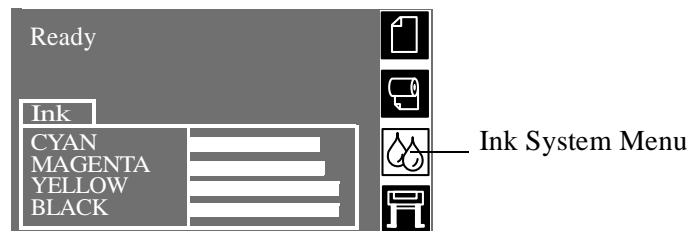

- 3 Press the ↑ or ↓ key until the front panel highlights “Printhead info”. Press the **Enter** key.

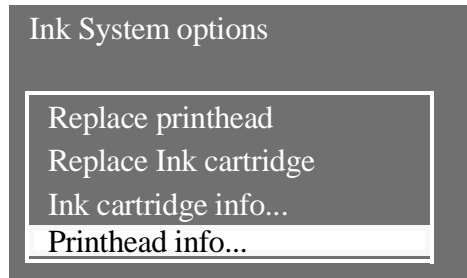

- 4 Press the ↑ or ↓ key until the front panel highlights the color that you want to see information on. Press the **Enter** key.

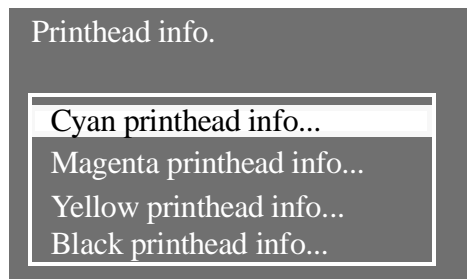

- 5 The front panel displays information on the selected printhead.

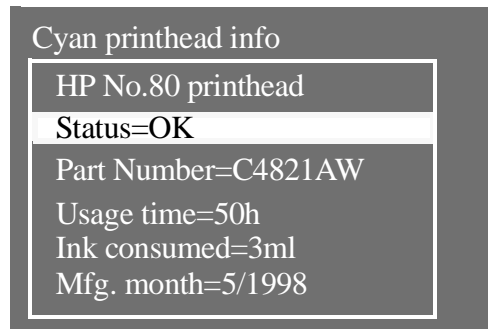

The information supplied is:

- The make of the printheads (HP No.80 are recommended).
- The current status of the printhead.
- Re-order part number of the printhead.
- The time that the printhead has been operating in the printer.
- How much ink has been consumed by the printhead. **Note:** It is possible for a printhead to consume more than one ink cartridge.
- The year and the month that the printhead was manufactured.

Ink Cartridge Status Messages

Status Bars

The front panel displays four horizontal bars. These bars represent how much ink is remaining in the ink cartridges: as ink is used up the bars get shorter in length. To see how much ink you have remaining, go to the 'Ink Cartridge Info' menu. See page 3-8, *Obtaining Ink Cartridge Information*

Ink Cartridge Status While Printing

Low

The **Low** message is an early warning sign and it is advisable that new supplies should be obtained of that particular color. The amount of ink remaining in the Ink Cartridge depends on its capacity:

- Approx. 43.8 ml remaining in a 175 ml Ink Cartridge.
- Approx. 63.8 ml remaining in a 350 ml Ink Cartridge.

To check how much ink is remaining, refer to page 3-8, *Obtaining Ink Cartridge Information*.

Very Low

When the **Very Low** message is displayed, overnight printing should not be attempted. Changing the Ink Cartridge is strongly recommended to prevent the printer from stopping halfway through a print. The amount of ink remaining in the Ink Cartridge will be approx. 25 ml.

To check how much ink is remaining, refer to page 3-8, *Obtaining Ink Cartridge Information*.

Empty

The printer will stop and will not be able to continue printing until a new ink cartridge has been installed. If this occurs halfway through printing an image, you should check the quality of this image, as stopping mid-plot can affect the print.

Ink Cartridge Status While Replacing

The printer can report the following status messages while the Ink Cartridge is being replaced:

Faulty	The ink cartridge is faulty and must be replaced, before you can continue printing.
Reseat	The ink cartridge is having continuity problems. Try reseating the Ink Cartridge.
Wrong Model	The ink cartridge is not recognized by the printer and needs to be replaced before the printer can continue.
Unknown	The ink cartridge installed is not approved and must be replaced by a genuine HP No.80 Ink Cartridge.

NOTE

The main actions for all 4 status messages is as follows:

- 1** Reseat the Ink Cartridge.
- 2** If reseating does not resolve the status message, replace the Ink Cartridge.
- 3** If the Status messages continue to appear, even after replacing the Ink Cartridge, replace the complete Tubes System ⇒ Page 8-53.

Printhead Status Messages While Printing

Detailed below are the printhead status messages that may be displayed while printing.

OK The printhead is operating correctly and will provide an acceptable level of print quality. To find more information on the printheads, refer to page 3-9, *Obtaining Printhead Information*.

Ready/Replace The front panel displays Ready and the printhead status is REPLACE. The printer is giving an early warning that there may be a degradation of print quality. The Printer has detected more than 4 black nozzles or 7 color nozzles out in 5 out of every 8 servicing procedures.

A new printhead should be bought. Depending on the print mode you are using (best, normal or draft) you may still be able to print with an acceptable print quality, there may be however, a slight loss in speed. Refer to the table below for more details.

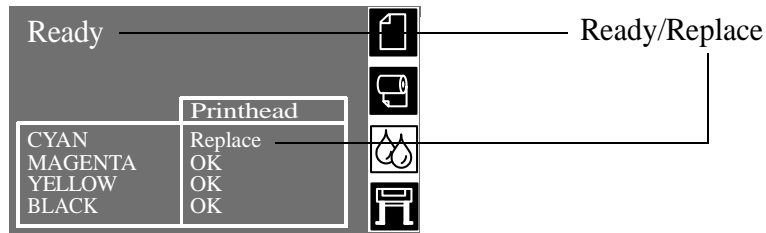

The printer can still operate with a printhead that needs replacing. The front panel will display:

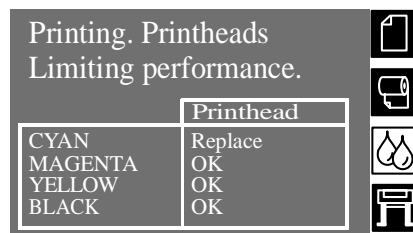

Front panel displays Ready/Replace		
Draft	Normal	Best
Print Quality is Affected	Print Quality is maintained but the printer changes the printing process to compensate for an ageing printhead. Subsequently the printer will print slower.	Printer will try to compensate for an ageing printhead
Speed not affected	Speed is affected	Speed not affected

Replace Printhead The front panel displays a warning, meaning that the printhead has quite a few nozzles operating incorrectly. There is a risk that media could be wasted. The printer will stop at the beginning of every print job and the front panel will display:

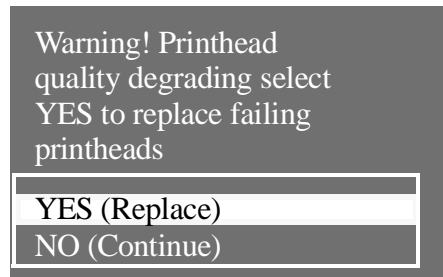

Press the ↓ or ↑ down key to select YES or NO. Press the **Enter** key. If you select **YES** the print job will be cancelled and a replacement will be started. If you say **NO**, the printer will continue printing. Next time you print, the same message will appear until you select YES (Replace).

Failed This message generally indicates that the printhead must be replaced. This situation must be corrected before the printer will operate. However, this problem may be corrected as follows:

- 1 Reseat the printhead.
- 2 Clean the Carriage and Printhead flex circuits using the Carriage Interconnect Wiper ⇒ Page 3-18.
- 3 If after reseating and cleaning the printhead, the failed message disappears but then reappears later, replace the printhead.

NOTE **If all 4 Printheads have the Status "Failed", it is possible that the Carriage Assembly is faulty.**

Monitor	<p>When this message is displayed it means that the printhead has reached its life expectancy.</p> <p>To find out how to see the amount of ink consumed by the printhead and the usage time, go to page 3-9, <i>Obtaining Printhead Information</i>.</p> <p>Printhead life is anticipated to be 700ml or twelve months (9,000 hours) in the printer, whichever occurs first, provided that the printhead is used under normal operating conditions (using HP ink cartridges only) and its “install before date” has not lapsed. However results vary depending on the print quality setting used. The printer will attempt to warn the user when this stage is reached with the monitor message.</p> <p>Even with the monitor message being displayed good image quality can still be obtained, but it could start degrading. The customer will have to check the images being printed and decide if they are of an acceptable print quality. If the customer wants to ensure optimum print quality with maximum unattendedness, they should consider buying a new printhead and replacing the old printhead with a new one.</p>
----------------	--

Printhead Status Messages While Replacing

The following are the printhead status messages that may be displayed while replacing the Printheads.

Setup	The Printer has detected that a Setup Printhead is installed.
Used	The Printer has detected that a USED Setup Printhead is installed.
Insert	<p>No Printhead has been detected in that Carriage stall. If a Printhead is installed in the Carriage stall when this status message is shown:</p> <ol style="list-style-type: none"> 1 Reseat the Printhead, making sure it is installed correctly. 2 Clean the Carriage and Printhead flex circuits using the Carriage Interconnect Wiper ⇒ Page 3-18. 3 Replace the Printhead. 4 Perform the Electronic Systems Test ⇒ Page 4-5.

NOTE If all 4 Printheads are installed but have the Status message "Insert", it is possible that the Carriage Assembly is faulty.

Reseat The printhead has moved slightly and is not making good electrical contact with the carriage assembly. Reseat the printhead into the correct position. This situation must be corrected before the printer will operate.

- 1 Reseat the Printhead in the correct position.
- 2 Clean the Carriage and Printhead flex circuits using the Carriage Interconnect Wiper ⇒ Page 3-18.
- 3 Replace the Printhead.
- 4 Perform the Electronic Systems Test ⇒ Page 4-5.

NOTE **If all 4 Printheads have the Status "Reseat", it is possible that the Carriage Assembly is faulty.**

Faulty The smartchip on the printhead is not correct or the digital communications between the Carriage and the Printhead is incorrect. This situation must be corrected before the printer will operate.

- 1 Reseat the Printhead.
- 2 Clean the Carriage and Printhead flex circuits using the Carriage Interconnect Wiper ⇒ Page 3-18.
- 3 Replace the Printhead.
- 4 Perform the Electronic Systems Test ⇒ Page 4-5.

NOTE **If all 4 Printheads have the Status "Faulty", it is possible that the Carriage Assembly is faulty.**

Wrong Model The printer does not recognize the printhead or printhead cleaner that you have inserted into the printer. You will have to remove it before the printer can continue.

CAUTION **If the Printing Printheads are installed in the carriage during the priming process, they will be rejected and the front panel will show the "Wrong Model" message.**

Unknown The Printhead installed is not approved and must be replaced by a genuine HP No.80 Printhead.

Summary of Solving HP No.80 Supplies Problems

Most of the problems that you could encounter when working with the HP No.80 supplies are solved with guidance from the front panel. A full list of front messages are supplied in the Users Guide.

Problems reseating the printhead

If you have inserted the printhead into the printhead carriage assembly and the printer does not “BEEP” try the following steps.

NOTE

Check that during the priming process, the Setup Printheads are installed in the Carriage. If the printing Printheads are installed in the carriage during the priming process, they will be rejected and the front panel will show the "Wrong Model" message.

- Check that you have removed the protective tape from the printhead.
- Insert the printhead into the carriage assembly but this time close the cover using the latch.
- Clean the electrical contacts on both the printheads and the printhead carriage assembly using the carriage interconnect wiper
⇒ Page 3-18
- Replace the printhead with a new one.

You Cannot Insert the Ink Cartridge Into the Printer

- 1 Ensure that you have the correct HP No.80 ink cartridge.
- 2 Ensure that the Ink Cartridge is the correct color for that slot.
- 3 Ensure that the Ink Cartridge is the correct orientation, with the color coded label at the top.

CAUTION

Never clean inside the ink cartridge slots.

You Cannot Insert the Printhead Into the Printer

- 1 Ensure that you have the correct HP No.80 printhead.
- 2 Ensure that the printhead is the correct color for that slot.
- 3 Ensure that the printhead is the correct orientation.
- 4 Ensure that the protective cap is removed from the Printhead.

You Cannot Insert the Printhead Cleaner Into the Printer

- 1 Ensure that you have the correct HP No.80 printhead cleaner.
- 2 Ensure that the printhead cleaner is the correct color for that slot.
- 3 Ensure that the printhead cleaner is the correct orientation.

Carriage Interconnect Wiper

NOTE

When you order the Carriage Assembly, the Carriage Interconnect Wiper will come with it. All the instructions needed to use the Carriage Interconnect Wiper will be packaged with the part.

Whenever you replace the printhead, check the empty slots to see if they need cleaning. In extreme circumstances, when a printhead is inserted, it is possible that the printer will not recognize it due to the build-up of ink on the electrical connection between the printhead and the printhead carriage.

Included with the HP DesignJet Printer, is a Carriage Interconnect Wiper. This tool is provided in a separate package. It also contains replacement sponges and an instruction sheet. This tool should be used for cleaning the electrical interconnects of both the printhead carriage and the printhead.

If the front panel displays the message “Reset” or possibly “Failed” next to the offending printhead, try cleaning the flex circuits of the carriage and the Printheads.



NOTE

Do not touch, wipe or attempt to clean the printhead nozzles. This can damage the printhead and reduce print quality.

Service Tests and Utilities

4

- Introduction 4-2
 - Diagnostics - Self Test 4-2
- Service Tests (Diagnostics) 4-3
 - Entering the Service Tests Menu 4-4
 - 1. Electronic Systems 4-5
 - 2. EIO Card 4-10
 - 3. Hard Disk Drive 4-12
 - 4. Ink Pressure System 4-14
 - 5. Scan Axis 4-17
 - 6. Paper Axis 4-20
 - 7. Drop Detector 4-22
- Service Utilities 4-25
 - Entering the Service Utilities Menu 4-26
 - 1. Tubes Purge 4-28
 - 2. Release Info 4-32
 - 3. Set Asian PS Fonts 4-33
 - 4. Printer Model Type 4-35
 - 5. Overdrive Cleaning 4-37
 - 6. EEROM Utilities 4-38
 - 7. Printhead Check 4-41
 - 8. Mon. Mode Baud Sel. 4-42

Introduction

This chapter explains how to use the built-in Service Tests and Service Utilities and what to do if any of the Service Tests fail. If possible, always perform a Service Test on the component that you are about to replace, just to make sure that is the component that has failed. If the test on that component passes, there is no need to replace it.

Diagnostics - Self Test

Initialization Sequences

Whenever the Printer is switched ON, it automatically performs a series of internal self tests and mechanical initialization sequences. If any of the parts fail, a system error will appear and you should consult Chapter 2 - *System Error Codes*.

Service Tests (Diagnostics)

The following is a list of all internal Service Tests available in the Printer. Instructions for entering the Service Tests menu are given on Page 4-4.

WARNING

The Service Tests work in a special Mode which does NOT require the full Initialization of the Printer. Therefore it is important that once you have finished with the Service Tests, you MUST power OFF the Printer and Power ON again before trying to print.

1 Electronics System ⇒ Page 4-5

The purpose of this test is to verify the operation of the:

- Electronics Module.
- DRAM.
- Trailing Cable.
- Carriage Assembly.

2 EIO Card ⇒ Page 4-10

The purpose of this test is to verify the operation of the EIO Card.

3 Hard Disk Drive ⇒ Page 4-12

The purpose of this test is to verify the operation of the Hard Disk Drive.

4 Ink Pressure System ⇒ Page 4-14

The purpose of this test is to verify the operation of the:

- Service Replaceable Kit (SRK).
- Air Pressurization System (APS).

5 Scan Axis ⇒ Page 4-17

The purpose of this test is to verify the operation of the Scan-Axis.

6 Paper Axis ⇒ Page 4-20

The purpose of this test is to verify the operation of the Paper-Axis.

7 Drop Detector ⇒ Page 4-22

The purpose of this test is to verify the operation of the Drop Detector.

Entering the Service Tests Menu

NOTE

In order to enter the Service Utility Menu, please refer to the instructions on Page 4-26.

- 1 Make sure the printer is switched OFF from the power switch on the front of the printer and **NOT** from the power switch on the back of the printer.
- 2 Hold the COLOR key down and switch the printer **ON** using the front power switch. Wait until the message "Initializing" is displayed on the front-panel before releasing the COLOR key.
- 3 Once inside the Service Tests Menu use the **Arrow** keys to scroll through the "Service Tests" selections.

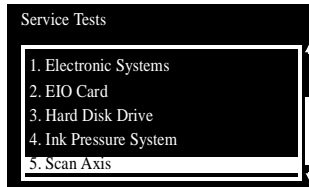

- 4 Press the **Enter** key to begin a specific test when the required Service Test is highlighted.

NOTE

If the printer is not used for 3 minutes, the printer hangs and you must repeat the above steps to enter the Service Mode again.

NOTE

In some cases a quick press of a button may not be recognized by the Printer. When pressing a button, be sure to press it deliberately and all the way to the bottom of its travel.

NOTE

If the Printer hangs up during a test, switch the Printer OFF and restart from step 1.

1. Electronic Systems

The purpose of this test is to verify the operation of the:

- Electronics Module.
- DRAM.
- Trailing Cable.
- Carriage Assembly.

NOTE

This test does not test the EIO Card or the Hard Disk Drive.

NOTE

The Service Tests work in a special Mode which does NOT require the full Initialization of the Printer. Therefore it is important that once you have finished with the Service Test, you MUST power OFF the Printer and Power ON again before trying to print.

WARNING

IF POSSIBLE ALWAYS PERFORM THIS TEST BEFORE REPLACING THE ELECTRONICS MODULE, TRAILING CABLE OR THE CARRIAGE ASSEMBLY. IF THIS TEST PASSES, DO NOT REPLACE THE ELECTRONICS MODULE, TRAILING CABLE OR THE CARRIAGE ASSEMBLY.

Tip for Repair

This test can be performed with just the Front Panel, Trailing Cable, Carriage, Electronics Module and the Power Cord connected together to isolate problems.

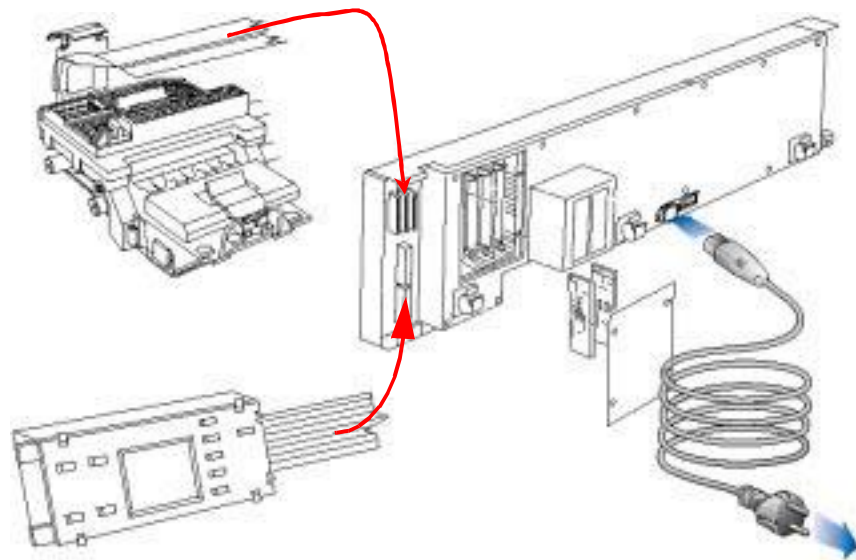

Perform the Electronic Systems test as follows:

- 1 In the Service Tests submenu, scroll to "1. Electronic Systems" and press **Enter**.

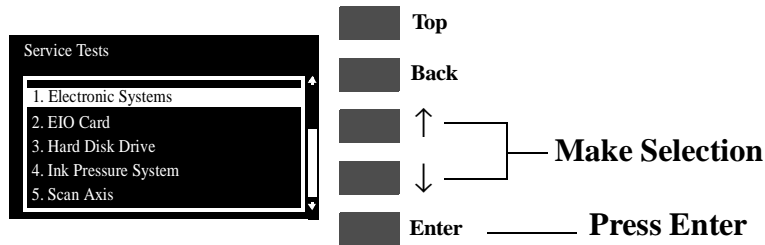

- 2 The test will start and the following sequence of messages will appear on the front panel:

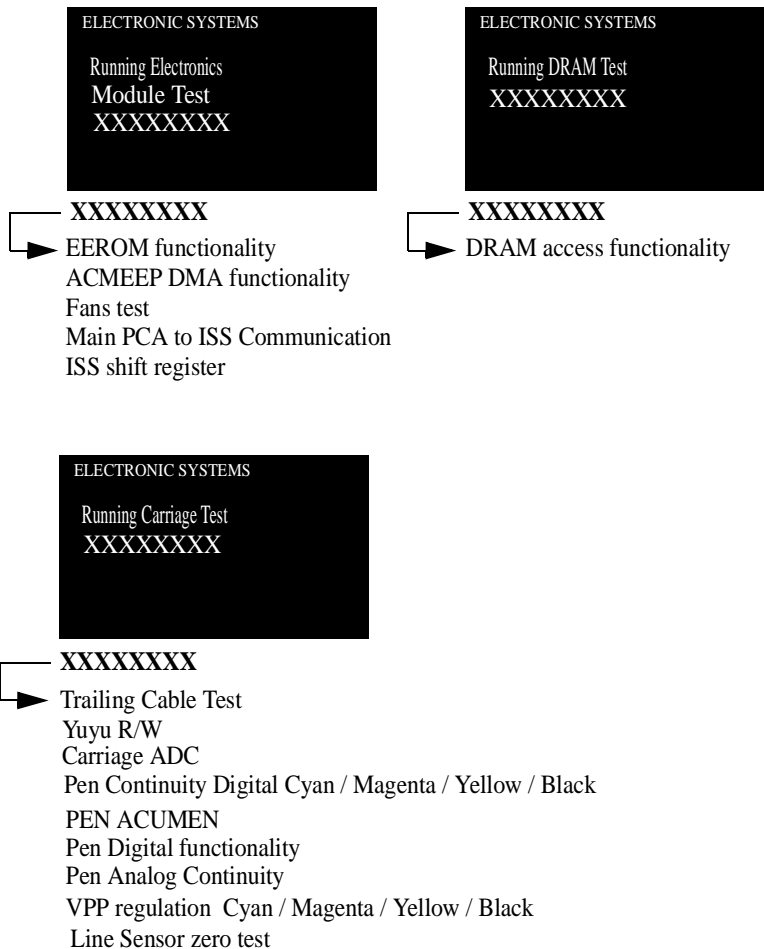

- 3 If the test passes, then the following message will appear on the front panel:

```

ELECTRONIC SYSTEMS

Tests passed
FW: A.00.13
PS: 6.0A77R
DIMM1: EDO 32MB 60ns
DIMM2: EDO 16 MB 60ns

```

WARNING

IF THIS TEST PASSES, DO NOT REPLACE THE ELECTRONICS MODULE, TRAILING CABLE OR THE CARRIAGE ASSEMBLY.

- 4 If the test fails.

Electronics Failure

If there is a problem with the components within the Electronics module then the following message will appear on the front panel:

```

ELECTRONIC SYSTEMS

Possible Failure on:
1. Electronics Module

Code: 00XXXX:0000XX

```

In this case, Replace the Electronics Module ⇒ Page 8-25.

DRAM Test Failure

If there is a problem with the DRAM then the following message will appear on the front panel:

```

ELECTRONIC SYSTEMS

Possible Failure on:
1. DRAM DIMMs
2. Electronics Module

Code: 00XXXX:0000XX

```

In this case, try one of the following:

- 1 *Switch the Power OFF from the back of the Printer and disconnect the Power cord. Reseat the DRAM DIMMs (Memory Modules), reconnect the power cord and power On the Printer. Perform the Electronic Systems Test again.*

- If the Test fails again, switch the Power OFF, disconnect the power cord and Replace the DRAM DIMMs (Memory Modules). Reconnect the power cord and power On the Printer and perform the test again.*
- Replace the Electronics Module ⇒ Page 8-25.*

WARNING

Only replace one component at a time and try the Service Test again before replacing another component. Using this procedure you will be able to determine exactly which component failed.

Trailing Cable Failure

If there is a problem with the Trailing Cable then the following message will appear on the front panel:

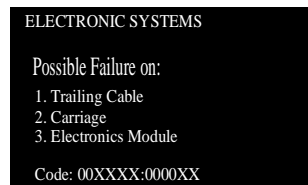

In this case, try one of the following:

- Make sure that the Trailing Cable is connected correctly.*
- Power OFF the Printer and connect a new Trailing Cable to the Carriage and the Electronics Module (without removing the old Trailing Cable from the Printer). Perform this test again and if the test FAILS, then DO NOT replace the trailing cable. If the test PASSES, replace the Trailing Cable ⇒ Page 8-39.*
- Power OFF the Printer and connect a new Carriage Assembly to the Trailing Cable (without removing the old Carriage Assembly from the Printer). Perform this test again and if the test FAILS, then DO NOT replace the Carriage Assembly. If the test PASSES, replace the Carriage Assembly ⇒ Page 8-44.*
- Power OFF the Printer and connect a new Electronics Module to the Trailing Cable (without removing the old Electronics Module from the Printer). Perform this test again and if the test FAILS, then DO NOT replace the Electronics Module. If the test PASSES, replace the Electronics Module ⇒ Page 8-25.*

WARNING

Only replace one component at a time and try the Service Test again before replacing another component. Using this procedure you will be able to determine exactly which component failed.

Carriage Test Failure

If there is a problem with the Carriage and any related parts then the following message will appear on the front panel:

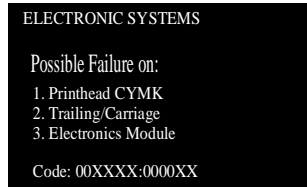

In this case, try one of the following:

- 1 *Remove the Printheads and clean the Carriage and Printhead flex circuits using the Carriage Interconnect Wiper ⇒ Page 3-18. Reinstall the Printheads and try the test again.*
- 2 *If the test fails again, replace the Printheads.*
- 3 *Make sure that the Trailing Cable is connected correctly to the Carriage Assembly and to the Electronics Module.*
- 4 *Power OFF the Printer and connect a new Trailing Cable to the Carriage and the Electronics Module (without removing the old Trailing Cable from the Printer). Perform this test again and if the test FAILS, then DO NOT replace the trailing cable. If the test PASSES, replace the Trailing Cable ⇒ Page 8-39.*
- 5 *Power OFF the Printer and connect a new Carriage Assembly to the Trailing Cable (without removing the old Carriage Assembly from the Printer). Perform this test again and if the test FAILS, then DO NOT replace the Carriage Assembly. If the test PASSES, replace the Carriage Assembly ⇒ Page 8-44.*
- 6 *Power OFF the Printer and connect a new Electronics Module to the Trailing Cable (without removing the old Electronics Module from the Printer). Perform this test again and if the test FAILS, then DO NOT replace the Electronics Module. If the test PASSES, replace the Electronics Module ⇒ Page 8-25.*

WARNING

Only replace one component at a time and try the Service Test again before replacing another component. Using this procedure you will be able to determine exactly which component failed.

2. EIO Card

The purpose of this test is to verify the operation of the EIO Card.

WARNING

IF POSSIBLE ALWAYS PERFORM THIS TEST BEFORE REPLACING THE EIO CARD. IF THIS TEST PASSES, DO NOT REPLACE THE EIO CARD.

NOTE

The Service Tests work in a special Mode which does NOT require the full Initialization of the Printer. Therefore it is important that once you have finished with the Service Test, you MUST power OFF the Printer and Power ON again before trying to print.

Perform the EIO Card test as follows:

- 1 In the Service Tests submenu, scroll to "2. EIO Card" and press **Enter**.

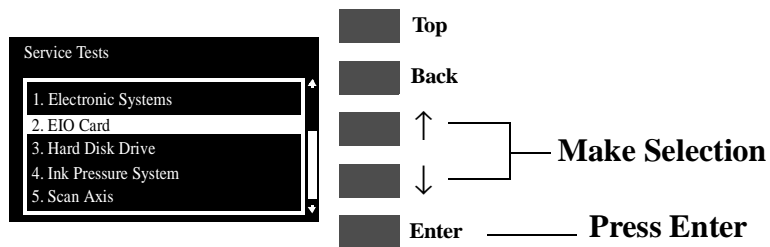

- 2 The test will start and the following message will appear on the front panel:

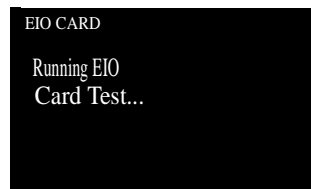

- 3 If the test passes, then the following message will appear on the front panel:

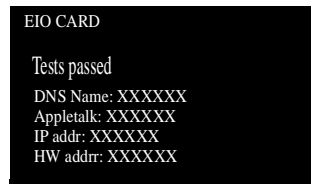

WARNING**IF THIS TEST PASSES, DO NOT REPLACE THE EIO CARD.**

If there is a problem with the EIO Card then the test will fail and the following message will appear on the front panel:

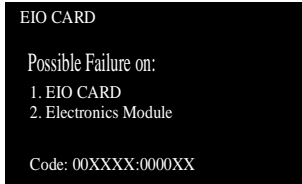
**NOTE**

Check that the EIO Card is actually installed before starting to troubleshoot. If the EIO Card is NOT installed, the test will of course always fail.

In this case, to resolve the problem, try the following:

- 1 Switch the printer OFF. Remove the Hard Disk Drive (if installed) and reinstall the EIO Card making sure it installed correctly by pushing it firmly inwards and checking that the two installation screws are completely tightened. Switch the printer ON again and repeat the EIO Card Test. If the EIO Card Test fails again then replace the EIO card.*
- 2 If the EIO Card Test **passed** after removing the Hard Disk Drive, then switch the Printer OFF and reinstall the Hard Disk Drive, making sure that the two installation screws are completely tightened. Switch the Printer ON again and repeat the EIO Card Test. If the EIO Card Test fails, then the Hard Disk Drive could be faulty. Replace the Hard Disk Drive.*
- 3 If the EIO Card Test continues to fail after replacing the EIO card or the Hard Disk Drive, then replace the Electronics Module ⇒ Page 8-25.*

WARNING

Only replace one component at a time and try the Service Test again before replacing another component. Using this procedure you will be able to determine exactly which component failed.

3. Hard Disk Drive

The purpose of this test is to verify the operation of the Hard Disk Drive.

WARNING

IF POSSIBLE ALWAYS PERFORM THIS TEST BEFORE REPLACING THE HARD DISK DRIVE. IF THIS TEST PASSES, DO NOT REPLACE THE HARD DISK DRIVE.

NOTE

The Service Tests work in a special Mode which does NOT require the full Initialization of the Printer. Therefore it is important that once you have finished with the Service Test, you MUST power OFF the Printer and Power ON again before trying to print.

Perform the Hard Disk Drive test as follows:

- 1 In the Service Tests submenu, scroll to "3. Hard Disk Drive" and press **Enter**.

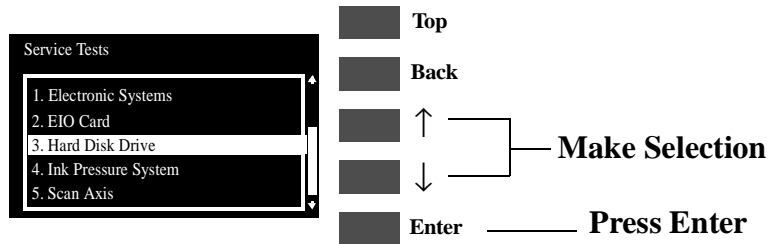

- 2 The test will start and the following message will appear on the front panel:



- 3 If the test passes, then the following message will appear on the front panel:



WARNING

IF THIS TEST PASSES, DO NOT REPLACE THE HARD DISK DRIVE.

If there is a problem with the Hard Disk Drive then the test will fail and the following message will appear on the front panel:



NOTE

Check that the Hard Disk Drive is actually installed before starting to troubleshoot. If the Hard Disk Drive is NOT installed, the test will of course always fail.

In this case, to resolve the problem, try the following:

- 1 Switch the printer OFF. Remove the EIO Card (if installed) and reinstall the Hard Disk Drive making sure it installed correctly by pushing it firmly inwards and checking that the two installation screws are completely tightened. Switch the printer ON again and repeat the Hard Disk Drive Test. If the Hard Disk Drive Test fails again then replace the Hard Disk Drive.*
- 2 If the Hard Disk Drive Test **passed** after removing the EIO Card, then switch the Printer OFF and reinstall the EIO Card, making sure that the two installation screws are completely tightened. Switch the Printer ON again and repeat the Hard Disk Drive Test. If the Hard Disk Drive Test fails, then the EIO Card could be faulty. Replace the EIO Card.*
- 3 If the Hard Disk Drive Test continues to fail after replacing the EIO card or the Hard Disk Drive, then replace the Electronics Module ⇒ Page 8-25.*

WARNING

Only replace one component at a time and try the Service Test again before replacing another component. Using this procedure you will be able to determine exactly which component failed.

4. Ink Pressure System

The purpose of this test is to verify the operation of the:

- Tubes System.
- Air Pressurization System (APS).

WARNING

IF POSSIBLE ALWAYS PERFORM THIS TEST BEFORE REPLACING THE TUBES SYSTEM OR THE APS. IF THIS TEST PASSES, DO NOT REPLACE THE TUBES SYSTEM OR THE APS.

NOTE

The Service Tests work in a special Mode which does NOT require the full Initialization of the Printer. Therefore it is important that once you have finished with the Service Test, you MUST power OFF the Printer and Power ON again before trying to print.

Perform the Ink Pressure System test as follows:

- 1 In the Service Tests submenu, scroll to "4. Ink Pressure System" and press **Enter**.

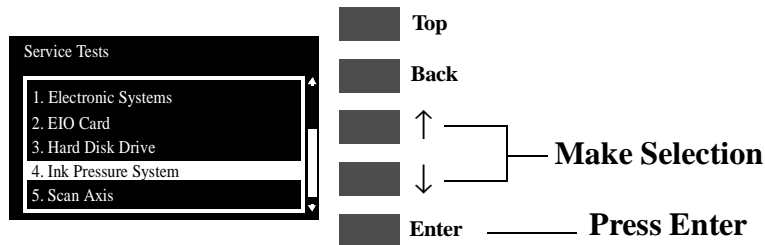

- 2 The test will start and the following sequence of messages will appear on the front panel:

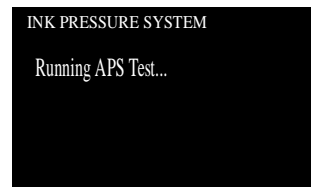
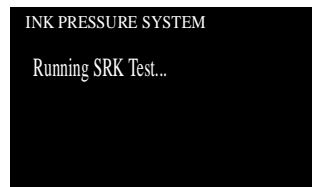

- 3 If the test passes, then the following message will appear on the front panel:

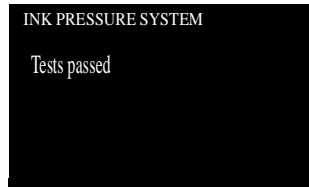

WARNING

IF THIS TEST PASSES, DO NOT REPLACE THE TUBES SYSTEM OR THE APS.

- 4 If the test fails.

Tubes System Failure

If there is a problem with the Tubes System then the following message will appear on the front panel:

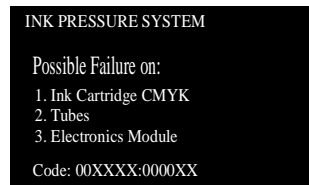

In this case, try one of the following:

- 1 *Replace ALL the Ink Cartridges.*
- 2 *Replace the complete Tubes System ⇒ Page 8-53.*
- 3 *Replace the Electronics Module ⇒ Page 8-25.*

WARNING

Only replace one component at a time and try the Service Test again before replacing another component. Using this procedure you will be able to determine exactly which component failed.

APS Test Failure

If there is a problem with the APS then the following message will

appear on the front panel:

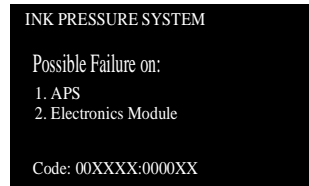

In this case, try one of the following:

- 1** *Check all the cables of the APS and make sure they are correctly connected and are NOT damaged.*
- 2** *Check all the tubes of the APS and make sure they are NOT pinched or damaged.*
- 3** *Replace ALL the Ink Cartridges.*
- 4** *Replace the complete APS ⇒ Page 8-20.*
- 5** *Replace the Electronics Module ⇒ Page 8-25.*

WARNING

Only replace one component at a time and try the Service Test again before replacing another component. Using this procedure you will be able to determine exactly which component failed.

5. Scan Axis

The purpose of this test is to verify the operation of the Scan Axis Motor.

You must perform the Scan-Axis Test after:

- Scan-Axis Assemblies are disassembled or replaced.
- Carriage is disassembled or replaced.
- Electronics Module is replaced.
- Tubes System is disassembled or replaced.

WARNING

ALL THE COVER SENSORS ARE DISABLED WHEN IN THE SERVICE TESTS MENU. IF THE CARRIAGE IS MOVING IT WILL NOT STOP IF THE WINDOW IS OPENED, SO BE VERY CAREFUL NOT TO PUT YOUR HANDS INSIDE.

WARNING

IF POSSIBLE ALWAYS PERFORM THIS TEST BEFORE REPLACING THE SCAN AXIS MOTOR. IF THIS TEST PASSES, DO NOT REPLACE THE SCAN AXIS MOTOR.

NOTE

The Service Tests work in a special Mode which does NOT require the full Initialization of the Printer. Therefore it is important that once you have finished with the Service Test, you MUST power OFF the Printer and Power ON again before trying to print.

Perform the Scan Axis test as follows:

NOTE

Perform this test with the Printheads and the Tubes System installed in order to get values that can be compared correctly.

- 1** In the Service Tests submenu, scroll to "5. Scan Axis" and press **Enter**.

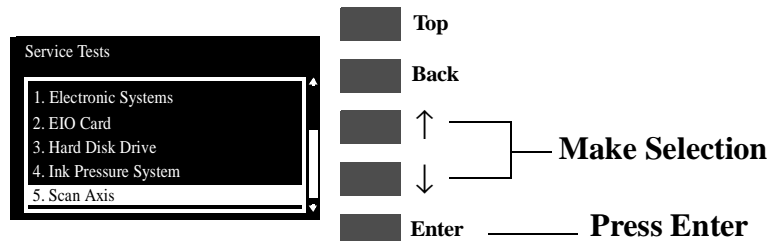

- The test will start and the following message will appear on the front panel:

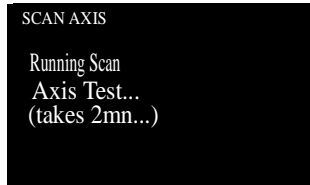

- Once the test is completed, the following message will appear on the front panel:



- Press **Enter** and the following message will appear on the front panel:

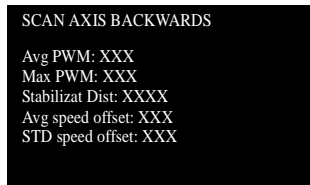

To check if the values displayed after the test are within the limits, refer to the following table:

	Scan-Axis Forward		Scan-Axis Backwards	
	Normal	Maximum	Normal	Maximum
Avg. PWM	165	185	-165	-185
Max. PWM	220	240	220	240
Stabilize Dist.	1800	2400	1800	2400
Avg. Speed offset	2.4	10	2.4	10
STD Speed offset	4.4	10	4.4	10

*If the values obtained in the test are **less** than the Maximum values in the previous table, then the test has **passed**.*

*If the values obtained in the test are **greater** than the Maximum values in the previous table, then the test has **failed**. To resolve the problem, try the following:*

- 1** *Clean the Slider Rods and Apply Oil along the complete axis of the Slider Rods. After applying the Oil, perform the test again.*
- 2** *Check that the Encoder Strip is clean. If necessary, clean Encoder Strip using a damp cloth.*
- 3** *Check that the Tubes System is installed correctly.*
- 4** *Check that the Carriage Belt and pulleys are installed correctly.*
- 5** *Replace the Scan-Axis Motor ⇒ Page 8-33.*

6. Paper Axis

The purpose of this test is to verify the operation of the Paper Axis Motor.

WARNING

IF POSSIBLE ALWAYS PERFORM THIS TEST BEFORE REPLACING THE PAPER AXIS MOTOR. IF THIS TEST PASSES, DO NOT REPLACE THE PAPER AXIS MOTOR.

NOTE

The Service Tests work in a special Mode which does NOT require the full Initialization of the Printer. Therefore it is important that once you have finished with the Service Test, you MUST power OFF the Printer and Power ON again before trying to print.

NOTE

Make sure you perform this test with NO media loaded.

Perform the Paper Axis test as follows:

- 1 In the Service Tests submenu, scroll to "6. Paper Axis" and press **Enter**.

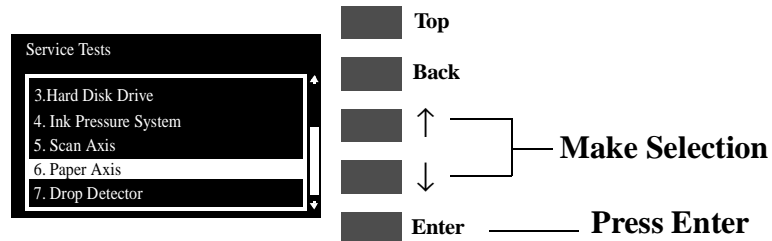

- 2 The test will start and the following messages will appear on the front panel:

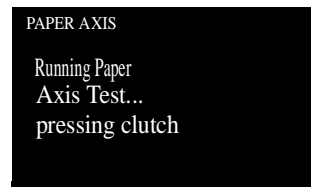
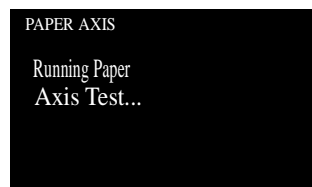

- 3 Once the test is completed, the following message will appear on the front panel:

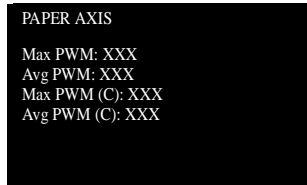

```
PAPER AXIS
Max PWM: XXX
Avg PWM: XXX
Max PWM (C): XXX
Avg PWM (C): XXX
```

If the values of the Max. PWM is less than 95 and the Avg. PWM is less than 85, then the test has passed.

*If the values of the Max. PWM is **more** than 95 and the Avg. PWM is **more** than 85, then the test has failed. To resolve the problem, try the following:*

- 1 *Open the Window and check for any visible obstacles restricting the movement of the Drive Roller or the Overdrive Assembly.*
- 2 *Replace the Paper-Axis Motor ⇒ Page 8-12.*

*If the values of the Max. PWM is **less** than 95 and the Avg. PWM is **less** than 85, but the values of the Max. PWM(C) is **more** than 100 and the Avg. PWM(C) is **more** than 90 then the test has failed. To resolve the problem, try the following:*

- 1 *Replace the Overdrive Assembly ⇒ Page 8-64.*

7. Drop Detector

The purpose of this test is to verify the operation of the Drop Detector.

WARNING

IF POSSIBLE ALWAYS PERFORM THIS TEST BEFORE REPLACING THE DROP DETECTOR. IF THIS TEST PASSES, DO NOT REPLACE THE DROP DETECTOR.

NOTE

The Service Tests work in a special Mode which does NOT require the full Initialization of the Printer. Therefore it is important that once you have finished with the Service Test, you MUST power OFF the Printer and Power ON again before trying to print.

Perform the Drop Detector test as follows:

- 1 In the Service Tests submenu, scroll to "7. Drop Detector" and press **Enter**.

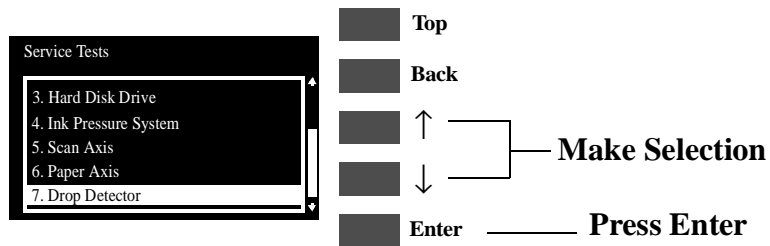

- 2 The test will start to initialize and the following message will appear on the front panel:

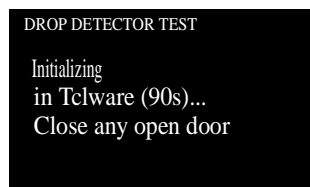

- 3 After initialization, the test will start and the following message will appear on the front panel:

DROP DETECTOR TEST
Running Drop
Detector Test...

WARNING

In the following step, make sure you do not drop the piece of paper inside the Drop Detector.

- 4 When the following message appears, open the Window and insert a thin piece of paper inside the Drop Detector in order to block it. Press any Front Panel key once the Drop Detector is blocked.

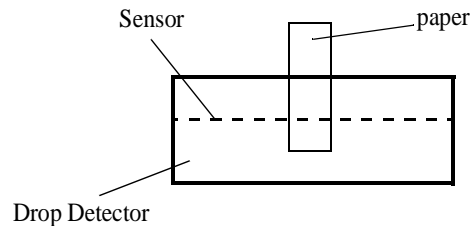

Block the Drop Detector
and press a FP key
when it is blocked

- 5 When the following message appears, remove the piece of paper from inside the Drop Detector and close the Window. Press any Front Panel key once the Window is closed.

Unblock Drop Detector
close the window
and press a FP key
to continue

- 6 The Printer will test the Drop Detector and the following message will appear on the front panel:

DROP DETECTOR TEST
Running Drop
Detector Test, ghost d

- 7 If the test passes, then the following message will appear on the front panel:

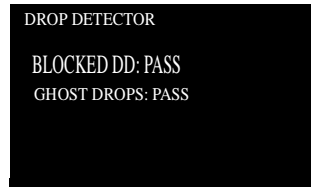

DROP DETECTOR
BLOCKED DD: PASS
GHOST DROPS: PASS

WARNING

IF THIS TEST PASSES, DO NOT REPLACE THE DROP DETECTOR.

If there is a problem with the Drop Detector then the following message will appear on the front panel:



DROP DETECTOR
Blocked DD: Fail
Code: 00XXXX:000XX

In this case, to resolve the problem, try the following:

- 1 *Check that the Drop Detector Cable is NOT broken or damaged.*
- 2 *Check that the Drop Detector cable is correctly connected to the Service Station Cable.*
- 3 *Check that the Service Station Cable is NOT broken or damaged.*
- 4 *Remove the Drop Detector and make sure that there are no obstacles inside which are blocking the sensor.*
- 5 *Replace the Drop Detector Assembly ⇒ Page 8-10.*
- 6 *If the test continues to fail, replace the Electronics Module ⇒ Page 8-25.*

WARNING

Only replace one component at a time and try the Service Test again before replacing another component. Using this procedure you will be able to determine exactly which component failed.

Service Utilities

The following is a list of all internal Service Utilities available in the Printers. Instructions for entering the Service Utilities menu are given on Page 4-26.

1 Tubes Purge ⇒ Page 4-28

The purpose of this Service Utility is to Prime the Tubes when a new Tubes System has been installed.

2 Release Info ⇒ Page 4-32

This Service Utility provides information on the current Firmware version.

3 Set Asian PS Font ⇒ Page 4-33

The purpose of this Service Utility is to set the Asian Fonts after replacing the Hard Disk Drive.

4 Printer Model Type ⇒ Page 4-35

The purpose of this Service Utility is to set the correct Printer Model.

5 Overdrive Cleaning ⇒ Page 4-37

The purpose of this Service Utility is to rotate the Overdrive in order to clean it.

6 EEROM Utilities ⇒ Page 4-38

The purpose of this Service Utility is to either clear the EEROM or to test it.

7 Printhead Check ⇒ Page 4-41

This Service Utility allows you to have the Printhead checking facility ON or OFF.

8 Mon. Mode Baud Sel. ⇒ Page 4-42

This Service Utility allows you to change the Baudrate of the Serial Port.

Entering the Service Utilities Menu

- 1 Once the message "Ready" is displayed on the front-panel, scroll to the "Printer Setup Options" icon and press the **Enter** key.

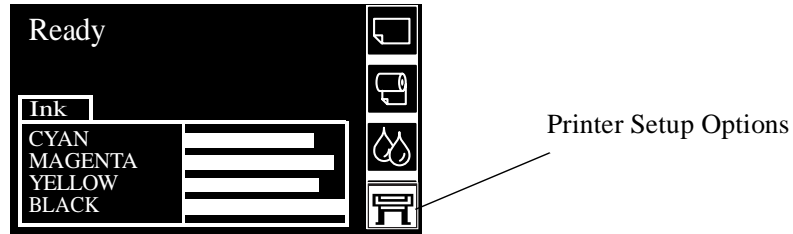

- 2 Once inside the "Printer Setup Options" menu, use the **Arrow** keys to scroll to the "Utilities" menu display and press the **Enter** key.

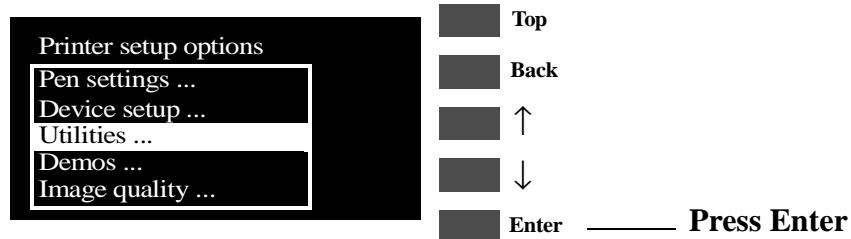

NOTE

Make sure that you are in the Full menu mode (Utilities / Menu / Full) because otherwise you will not be able to access the "Service Tools" submenu.

- 3 Once inside the "Utilities" menu, press the **UP** and **Enter** keys together. You are now in the **Service Tools** Menu.

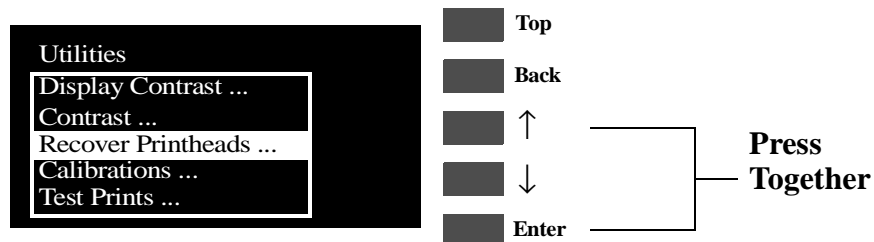

- 4 Use the **Arrow** keys to scroll to the "Service Utilities" menu and press the **Enter** key.

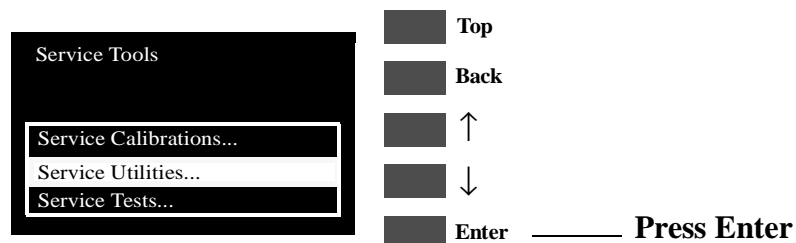

-
- 5 Use the **Arrow** keys to scroll through the "Service Utilities" selections.

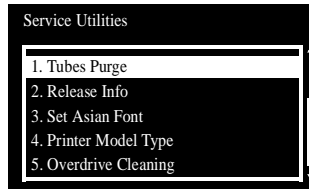

- 6 Press the **Enter** key to begin a specific operation when the required Service Utility is highlighted.

NOTE

If the printer is not used for 3 minutes, the printer exits out of the Service Utilities Menu and you must repeat the above steps to enter Service Utilities again.

NOTE

In some cases a quick press of a button may not be recognized by the Printer. When pressing a button, be sure to press it deliberately and all the way to the bottom of its travel.

NOTE

If the Printer hangs up during an operation, switch the Printer OFF and restart from step 1.

1. Tubes Purge

The purpose of this Service Utility is to Prime the Tubes when a new Tubes System has been installed.

WARNING

ALWAYS PERFORM THE TUBES PURGE AFTER REPLACING THE TUBES SYSTEM.

NOTE

Make sure that there is enough ink remaining in the Ink Cartridges before starting to prime the tubes. If there is not enough ink remaining, you will get a warning message.

Perform the Tubes Purge as follows:

- 1 In the Service Utilities submenu, scroll to "1. Tubes Purge" and press **Enter**.

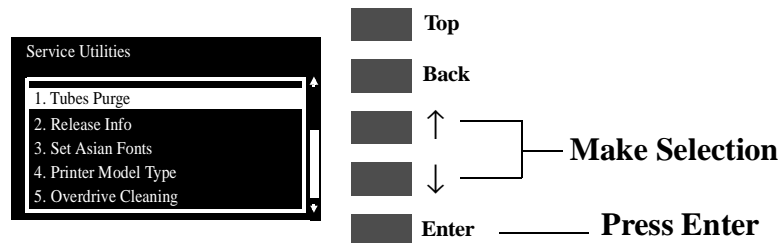

- 2 The Printer will begin to startup and in order to continue, press **Enter**.

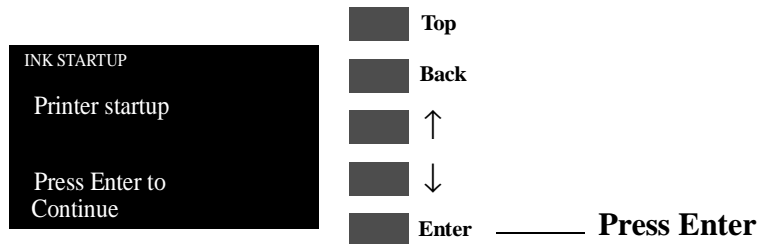

- 3 The following message will be displayed on the front panel while the printer accesses the printheads.



- 4 When the following message is displayed, lift the window and remove ALL the Printheads from the carriage. Install the Setup Printheads into the carriage.



INK STARTUP
Lift window to
install SETUP
printheads

- 5 Once all the Setup Printheads are installed, the following message will appear on the front panel. Close the carriage cover and close the window.



INK STARTUP
All SETUP printheads
are OK. Close cover
and window to
continue

- 6 The following messages will be displayed on the front panel while the printer accesses and then stores the printheads.



INK STARTUP
Accessing Printheads



INK STARTUP
Storing Printheads

- 7 The printer will then begin to purge the tubes system.



INK STARTUP
Initializing printer
Please wait. xx sec

- 8** Once the tubes system is purged, the following message will be displayed. Lift the window and remove ALL the Setup Printheads from the carriage and install the previously removed printing Printheads into the carriage.

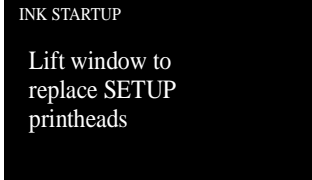

INK STARTUP
Lift window to
replace SETUP
printheads

- 9** Once all the Printheads are installed, the following message will appear on the front panel. Close the carriage cover and close the window.



INK STARTUP
All printheads
are OK. Close cover
and window to
continue

- 10** Open the right cover and make sure the Printhead Cleaners are installed in the Service Station.



INK STARTUP
Open right cover
and install printhead
cleaners

- 11** If media is not loaded, the following message appears on the front panel and you must load media into the Printer.



INK STARTUP
Load paper for
calibration

- 12 The Printer will start to print the Printhead Alignment Pattern and the following message will be displayed on the front panel:



- 13 Once the Printhead Alignment is completed, the following message will be displayed on the front panel:

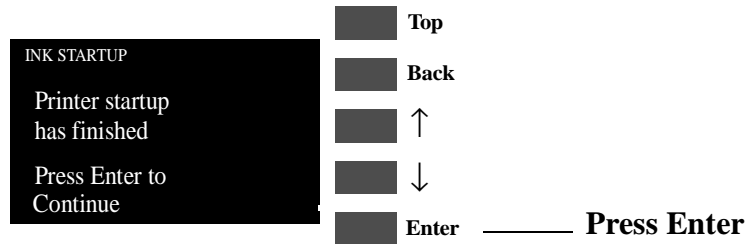

WARNING

Since you have replaced the Tubes System, make sure that you perform the **Calibrations Backup** (⇒ Page 5-19) in order to backup the EEROM Data from the Electronics Module. Make sure you select "Tubes Replaced" when performing the **Calibrations Backup**.

2. Release Info

This Service Utility provides information on the current Firmware version.

Check the Release Info as follows:

- 1 In the Service Utilities submenu, scroll to "2. Release Info" and press **Enter**.

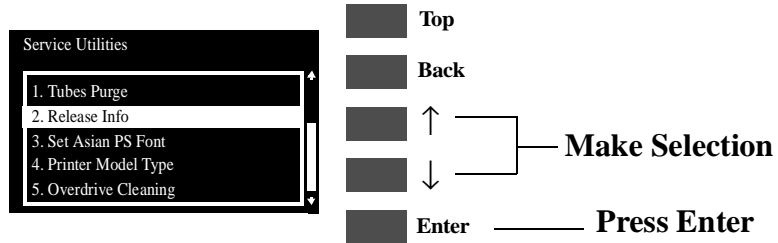

- 2 The Printer will display the Firmware information. An example is shown below.

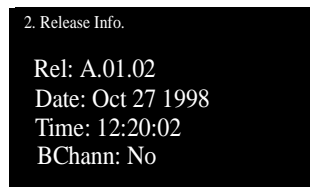

3. Set Asian PS Fonts

The purpose of this Service Utility is to select the Asian Fonts after replacing the Electronics Module.

WARNING ALWAYS SET THE ASIAN FONTS AFTER REPLACING THE ELECTRONICS MODULE.

NOTE If the customer is not using any internal Asian PS Fonts, then this Service Utility is not necessary.

Set the Asian PS Font as follows:

- 1 In the Service Utilities submenu, scroll to "3. Set Asian PS Font" and press **Enter**.

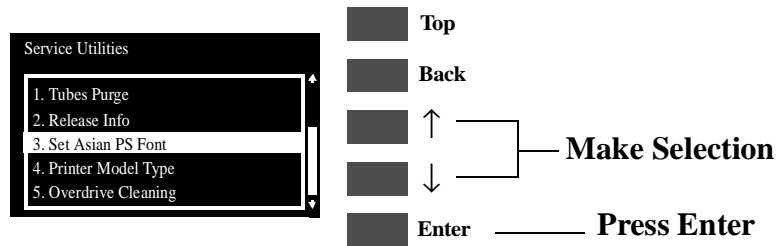

WARNING Make sure you select the correct Asian PS font. Once the first PostScript file has been received by the Printer, the rest of the Asian PS fonts will be deleted from the Electronics Module and there will be no way to recover them.

- 2 A list of ALL the Asian PS Fonts will be displayed and you must select the font that you require. Use the **Up** and **Down** arrow keys and press **Enter** once the selection has been made.

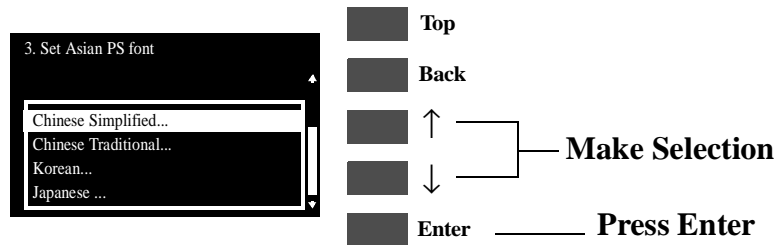

- 3 The following message will be displayed on the front panel asking you to confirm the selection. Select **ACCEPT** if you want to continue with your selection, or select **CANCEL** if you want to cancel it. Press **Enter** once the selection has been made.

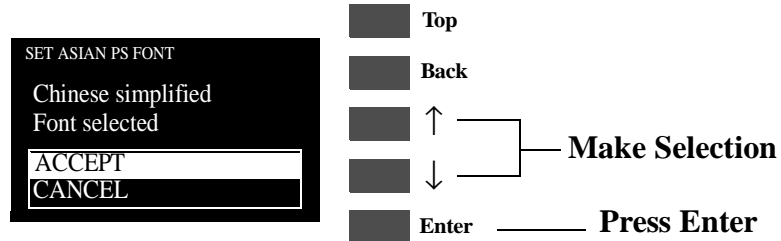

- 4 Once the Font selection has been made, the following message will be displayed on the front panel:

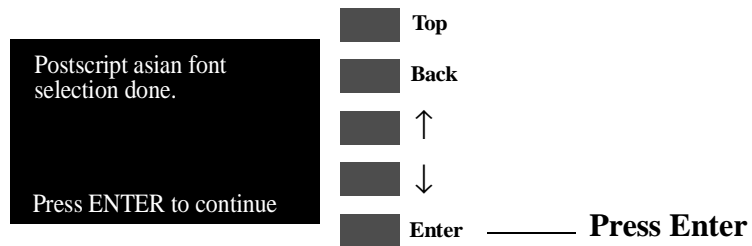

4. Printer Model Type

The purpose of this Service Utility is to set the correct Printer Model.

NOTE

The Printer Model Type only needs to be set when both the Tubes System and the Electronics Module have been replaced at the same time.

Set the Printer Model Type as follows:

- 1 In the Service Utilities submenu, scroll to "4. Printer Model Type" and press **Enter**.

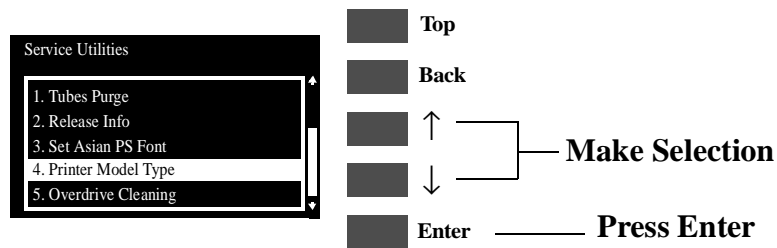

- 2 When the following message appears on the front panel, you must select which Printer Model you would like to set. Select either the HP DJ 1050C or the HP DJ 1055CM and press **Enter**.

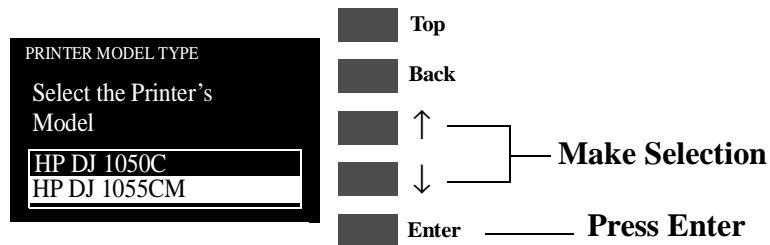

- 3 The following message will appear asking you to confirm the selection. Select **ACCEPT** if you want to set the Printer Model (selected in the previous step), or select **CANCEL** if you want to cancel the selection. Press **Enter** once the selection has been made.

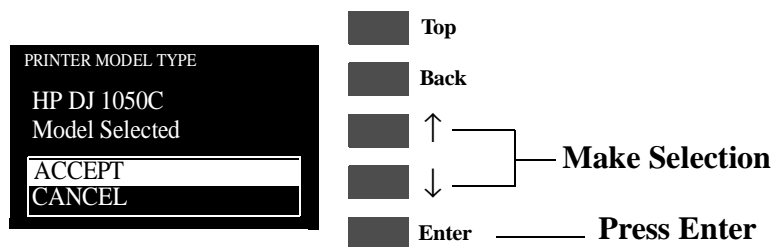

- 4 Once the Model Type selection has been made, the following message will be displayed on the front panel:

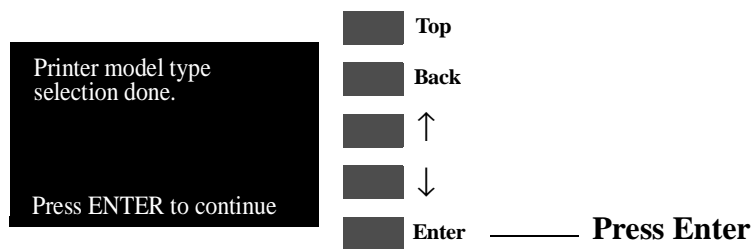

- 5 Print the Service Configuration Print (⇒ Page 1-19) and check if the Printer Model Type has been set correctly.

5. Overdrive Cleaning

The purpose of this Service Utility is to rotate the Overdrive, Drive Roller and Roller Mark in order to clean them.

NOTE

REMOVE THE MEDIA BEFORE PERFORMING THIS OPERATION.

WARNING

OPEN THE WINDOW OF THE PRINTER AND ACTIVATE THE WINDOW SENSOR (USING A PIECE OF PAPER) BEFORE PERFORMING THIS SERVICE UTILITY.

Perform the Overdrive Cleaning utility as follows:

- 1 In the Service Utilities submenu, scroll to "5. Overdrive Cleaning" and press **Enter**.

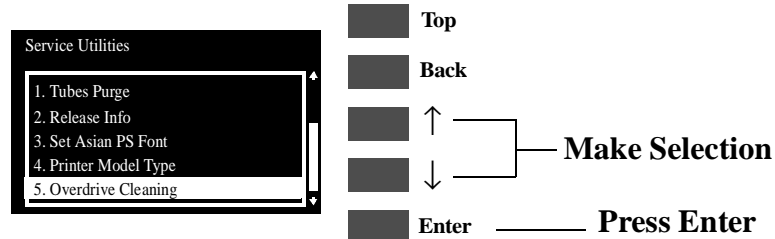

- 2 When the following message appears on the front panel, use the **Up** and **Down** arrow keys to select either to increase or decrease the speed. Press **ENTER** when the selection has been made and the speed will either increase or decrease depending on your selection.

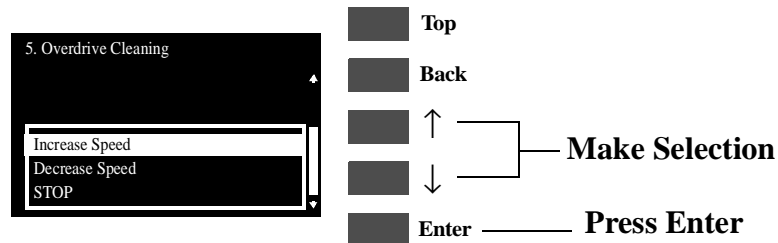

- 3 Refer to the Cleaning Instructions on Page 9-3.
- 4 To stop the Overdrive, select "STOP" and press **ENTER**.

6. EEROM Utilities

The purpose of this Service Utility is to either clear the EEROM in the Electronics Module or to test it.

Perform the Clear/Test EEROM utility as follows:

- 1 In the Service Utilities submenu, scroll to "6. EEROM Utilities" and press **Enter**.

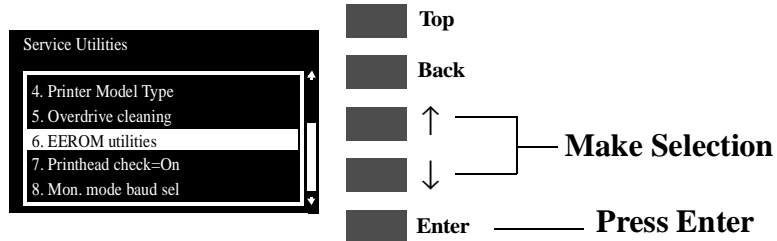

- 2 When the following message appears on the front panel, you must select whether you would like to either test the EEROM or clear it. Press **ENTER** once you have made your selection.

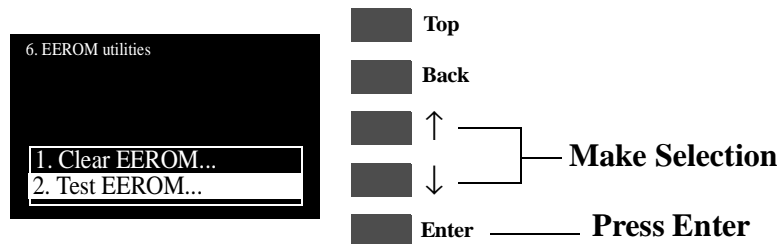

If you want to Test the EEROM

- a If you want to test the EEROM, then you should select "Test EEROM" and press ENTER. The following message will appear asking you to confirm the selection. Select **ACCEPT** if you want to continue, or select **CANCEL** if you want to cancel the test. Press **Enter** once the selection has been made.

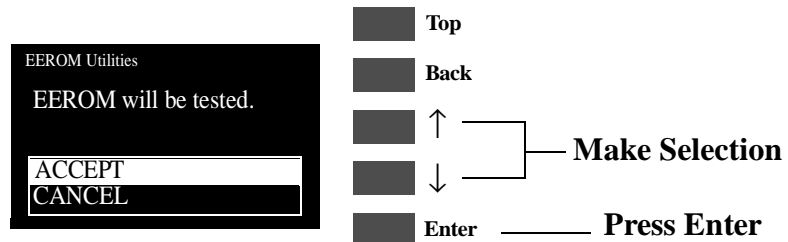

- b If you decided to continue with the test then the following message will appear on the front panel and you should wait until the test has been performed.

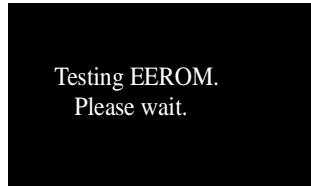

WARNING

DO NOT POWER OFF THE PRINTER WHILE THE TEST IS BEING PERFORMED BECAUSE THIS COULD DAMAGE THE ELECTRONICS MODULE.

- c Once the test has been completed, the following message will be displayed on the front panel.

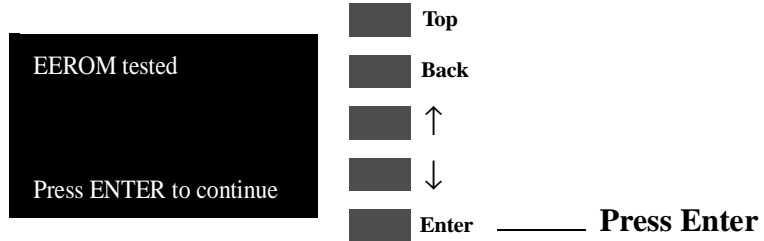

If you want to Clear the EEROM

- a If you want to clear the EEROM, then you should select "Clear EEROM" and press ENTER. The following message will appear asking you to confirm the selection. Select **ACCEPT** if you want to continue, or select **CANCEL** if you want to cancel the operation. Press **Enter** once the selection has been made.

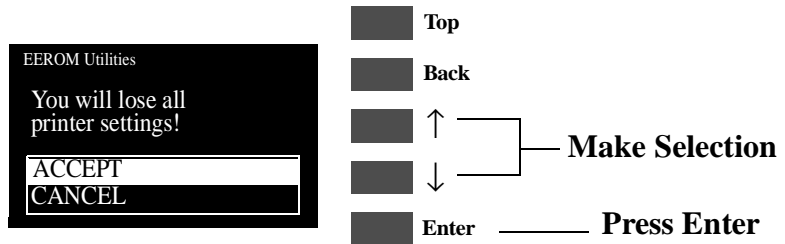

- b If you decided to continue with clearing the EEROM, then the following message will appear on the front panel and you should wait until the EEROM has been cleared.

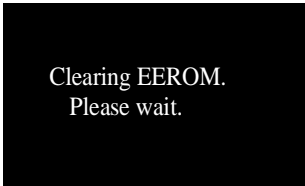

WARNING

DO NOT POWER OFF THE PRINTER WHILE THE EEROM IS BEING CLEARED BECAUSE THIS COULD DAMAGE THE ELECTRONICS MODULE.

- c Once the EEROM has been cleared, the following message will be displayed on the front panel.

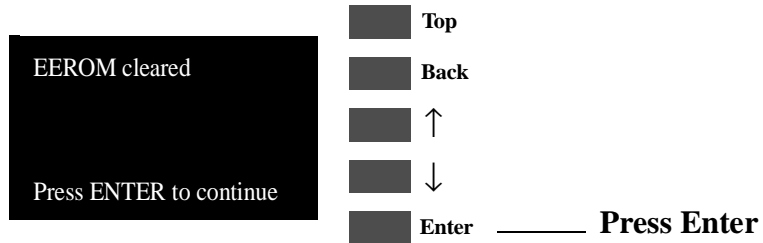

- d In order to recover the calibrations information, perform the Calibrations Backup (⇒ Page 5-19).
- e Also, if necessary, set the Asian PS Fonts (⇒ Page 4-33), selecting the Asian PS font that was set before clearing the EEROM.

7. Printhead Check

This Service Utility allows you to have the Printhead checking facility ON or OFF.

WARNING

ALWAYS HAVE PRINTHEAD CHECK ON. IF PRINTHEAD CHECK IS TURNED OFF, AUTOMATIC PRINTHEAD CLEANING PROCEDURES WILL NOT WORK PROPERLY, SHORTENING PRINTHEAD LIFE. ALSO BY TURNING OFF PRINTHEAD CHECK, PRINT QUALITY MAY BE LOWER BECAUSE THE PRINTER WILL NOT USE THE ERROR HIDING CAPABILITIES.

Turn the Printhead Check ON or OFF as follows:

- 1 In the Service Utilities submenu, scroll to "7. Printhead Check" and press **Enter**.

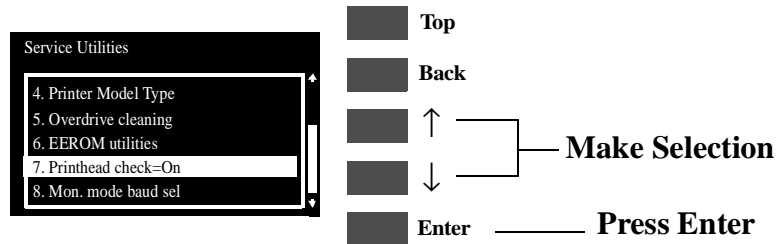

- 2 When the following message appears on the front panel, you must select whether you would like to turn the Printhead Check ON or OFF. Press **ENTER** once you have made your selection and a little symbol will be displayed next to your selection.

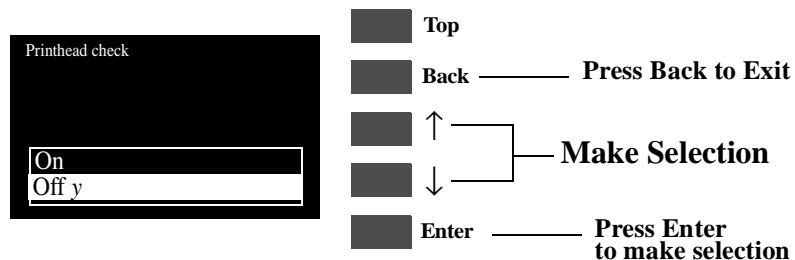

8. Mon. Mode Baud Sel.

This Service Utility allows you to change the Baudrate of the Serial Port.

NOTE The default Baudrate for serial communication is 14200.

Change the Baudrate as follows:

- 1 In the Service Utilities submenu, scroll to "8. Mon. Mode Baud Sel." and press **Enter**.

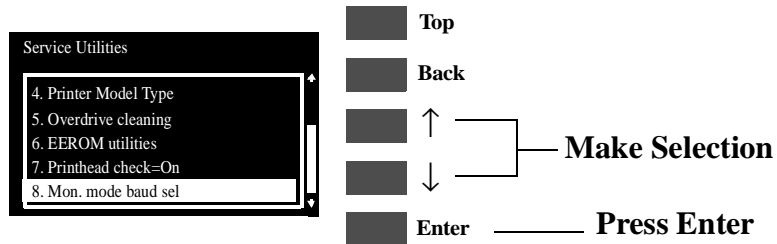

- 2 When the following message appears on the front panel, you must select the Baudrate setting using the **Up** and **Down** arrow keys. Press **ENTER** once you have made your selection.

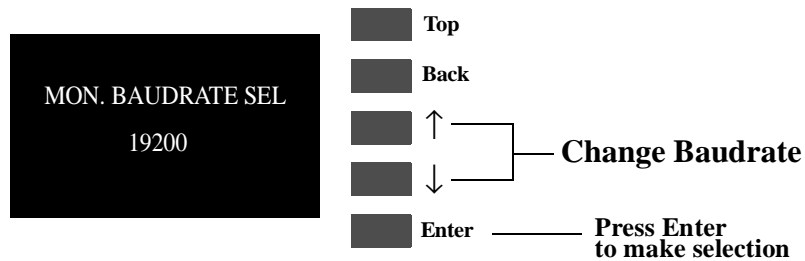

Service Calibrations

5

- Service Calibrations 5-2
- Entering the Service Calibrations Menu 5-4
- 1. Accuracy Calibration 5-6
- 2. Line Sensor 5-9
- 3. Service Station 5-11
- 4. Roller Mark Position 5-13
- 5. Pen to Paper Spacing 5-15
- 6. Color to Color calibration 5-16
- 7. Calibrations Backup 5-19
- 8. Pen Alignment 5-22
- Carriage Height Calibration 5-24

Service Calibrations

The Printer has several calibration procedures that must be performed under certain conditions. Refer to the table below to determine when calibrations are required.

WARNING

REMEMBER THAT CERTAIN CALIBRATIONS ARE REQUIRED EVEN IF AN ASSEMBLY HAS BEEN DISASSEMBLED TO GAIN ACCESS TO ANOTHER ASSEMBLY OR COMPONENT.

Done	Which Calibrations Need To Be									
	When Required	1	2	3	4	5	6	7	8	◆
	Carriage is disassembled or replaced	No	Yes	Yes	Yes	No	Yes	No	Yes	Yes
	Electronics Module is replaced	No	No	No	No	No	No	Yes	Yes	No
	Paper-Axis is disassembled or replaced	Yes	No	No	No	No	Yes	No	No	No
	Platen Assembly is disassembled or replaced	No	No	Yes	No	No	Yes	No	No	Yes
	Service Station is disassembled or replaced	No	No	Yes	No	No	Yes	No	No	No
	Drive Roller is disassembled or replaced	Yes	No	No	No	No	Yes	No	No	No
	Tubes System (SRK) is disassembled or replaced	No	No	No	No	No	No	Yes	Yes	No
	Banding Problem	Yes	Yes	No	No	No	No	No	Yes	No
	Misalignment between Colors	No	Yes	No	No	No	Yes	No	Yes	No
	Color Accuracy Problem	No	No	No	No	No	No	No	No	No
	Edge Detect Problems	No	Yes	No	No	No	No	No	No	No

NOTE

Refer to the following page for the relevant Calibration.

Service Calibrations

The following is a list of all internal service calibrations available in the Printers. Instructions for entering the service calibrations menu are given on Page 5-4.

1 Accuracy Calibration ⇒ Page 5-6

The purpose of this Service Calibration is to calibrate the nominal advance of the media. This calibration is necessary to control the exact movement of the media in order to avoid print quality problems like banding.

2 Line Sensor ⇒ Page 5-9

The purpose of this Service Calibration is to calibrate the intensity of the line sensor in the Carriage PCA. An incorrect calibration can result in edge-detection failures during media loading and incorrect reading of prints that are used for alignment or calibration.

3 Service Station ⇒ Page 5-11

The purpose of this Service Calibration is to calibrate the Service Station in relation to the Carriage Assembly.

4 Roller Mark Position ⇒ Page 5-13

The purpose of this Service Calibration is to calibrate the Mark Encoder which is located on the Drive Roller.

5 Pen to Paper Spacing ⇒ Page 5-15

THIS CALIBRATION IS NO LONGER REQUIRED.

6 Color to Color Calibration ⇒ Page 5-16

The purpose of this Service Calibration is to correct the alignment between the Printheads and the rest of the Printer. This calibration is necessary in order to prevent color misalignment.

7 Calibrations Backup ⇒ Page 5-19

The purpose of this Service Calibration is to allow the EEROM contents to be saved when the Electronics Module or the Tubes System is replaced.

8 Pen Alignment ⇒ Page 5-22

The purpose of this Service Calibration is to correct the alignment between the Printheads. This calibration is necessary in order to prevent color misalignment and print quality defects like banding.

◆ **Carriage Height Calibration** ⇒ Page 5-24

The purpose of this Service Calibration is to adjust the distance between the Carriage and the Center Platen. This calibration is necessary in order to prevent problems like Printhead crashes.

Entering the Service Calibrations Menu

- 1 Once the message "Ready" is displayed on the front-panel, scroll to the "Printer Setup Options" icon and press the **Enter** key.

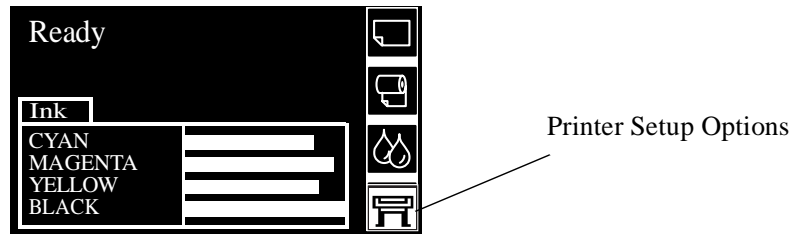

- 2 Once inside the "Printer Setup Options" menu, use the **Arrow** keys to scroll to the "Utilities" menu display and press the **Enter** key.

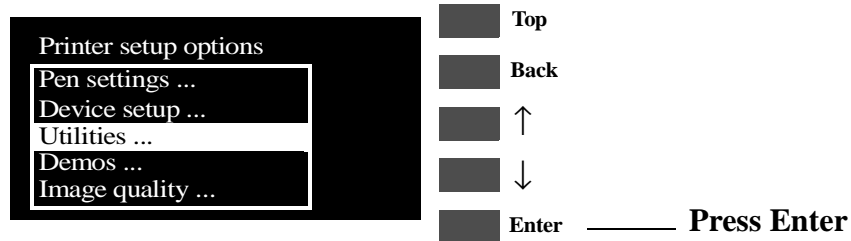

NOTE

Make sure that you are in the Full menu mode because otherwise you will not be able to access the "Service Tools" submenu.

- 3 Once inside the "Utilities" menu, press the **UP** and **Enter** keys together. You are now in the **Service Tools** Menu.

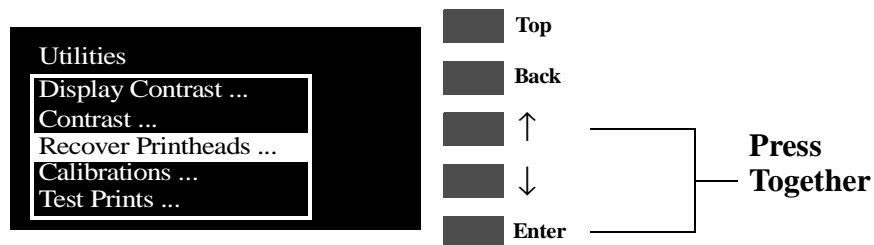

- 4 Use the **Arrow** keys to scroll to the "Service Calibrations" menu and press the **Enter** key.

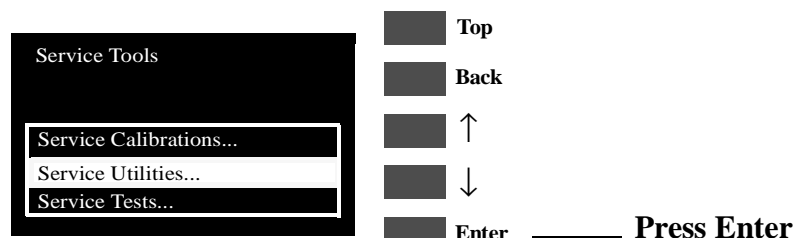

- 5 Use the **Arrow** keys to scroll through the "Service Calibrations" selections.

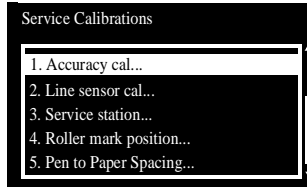

- 6 Press the **Enter** key to begin a specific calibration when the required Service Calibration is highlighted.

NOTE

If the printer is not used for 3 minutes, the printer exits out of the Service Calibrations Menu and you must repeat the above steps to enter Service Calibrations again.

NOTE

In some cases a quick press of a button may not be recognized by the Printer. When pressing a button, be sure to press it deliberately and all the way to the bottom of its travel.

NOTE

If the Printer hangs up during an operation, switch the Printer OFF and restart from step 1.

1. Accuracy Calibration

The purpose of this Service Calibration is to calibrate the nominal advance of the media. This calibration is necessary to control the exact movement of the media in order to avoid print quality problems like banding.

Perform the Service Accuracy Calibration whenever:

- Banding is detected in prints.
- Drive Roller is disassembled or replaced.
- Paper-axis Assembly is disassembled or replaced.

Perform the Accuracy Calibration as follows:

NOTE

Make sure you load HP High Gloss Photo Paper in to the Printer before performing this calibration. Do NOT use any other type of media apart from HP High Gloss Photo Paper.

- 1 In the Service Calibrations submenu, scroll to "1. Accuracy cal" and press **Enter**.

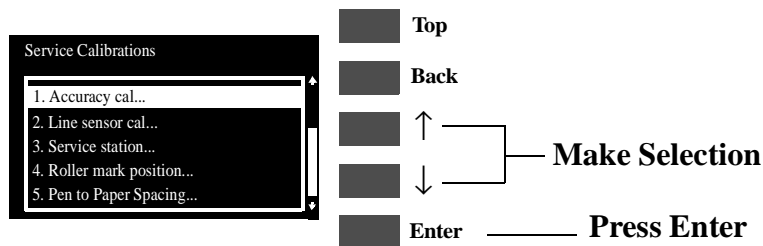

- 2 When the following message appears on the front panel, select "Create Pattern" and press **Enter**.

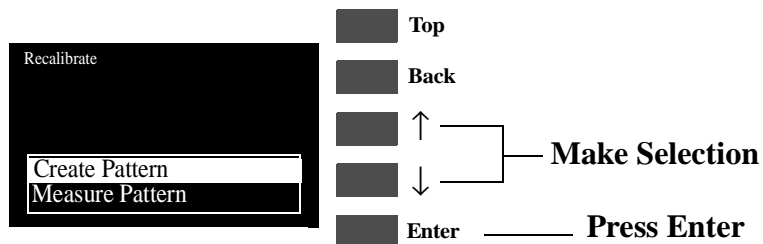

- 3 If media is not loaded, the following message appears on the front panel and you must load media into the Printer.

NOTE

Do NOT use any other type of media apart from HP High Gloss Photo Paper.

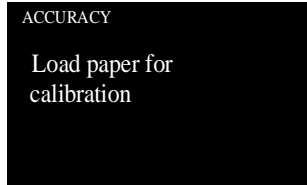

- 4 The Printer will start to print the Accuracy Calibration Pattern and the following message will be displayed on the front panel:



- 5 Once the Accuracy Calibration Pattern is completed, the following message will be displayed. Remove the pattern from the media and select "Measure Pattern" and press **Enter**.

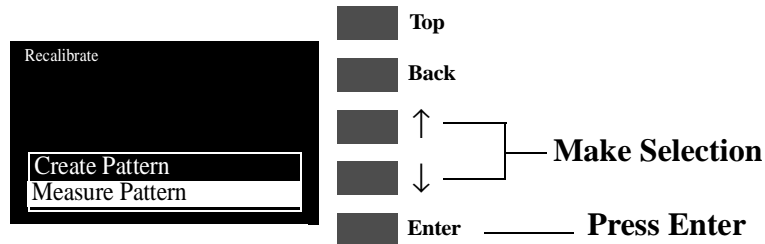

- 6 Rotate the pattern so that the edge with the arrows points to the leading edge, and then reload the pattern with the arrow edge print facing down.
- 7 The Printer will load the pattern and then measure the alignment marks using the line sensor on the Carriage Assembly. The

following message will be displayed while the Printer measures the pattern:

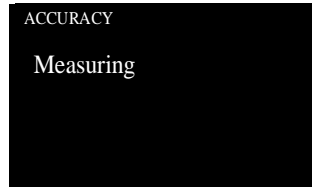

- 8 Once the calibration is completed, the following message will be displayed:

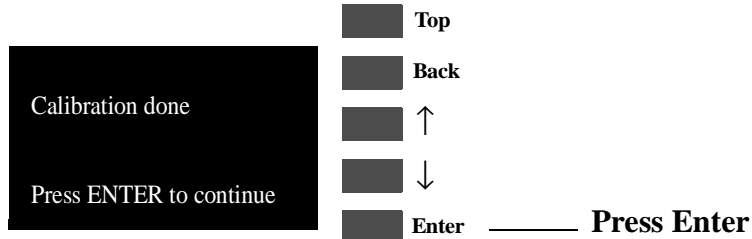

- 9 To check if the Calibration was completed correctly, print the Service Configuration Print (see Page 1-19) and check that the values given for the Accuracy Calibration are NOT ALL zero.

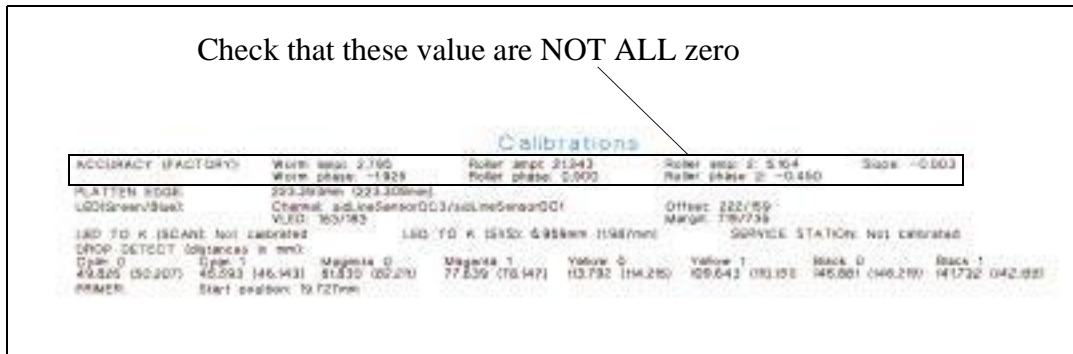

- 10 If the calibration fails *Perform the Electronic Systems Test* ⇒ Page 4-5.

2. Line Sensor

The purpose of this Service Calibration is to calibrate the intensity of the line sensor in the Carriage PCA. An incorrect calibration can result in edge-detection failures during media loading and incorrect reading of prints that are used for alignment or calibration.

Perform the Line Sensor Calibration whenever:

- Edge detect procedure fails during media loading.
- Carriage is disassembled or replaced.
- Banding is detected in prints.
- Misalignment between colors is detected.

Perform the Line Sensor Calibration as follows:

NOTE

Make sure you load HP Coated media in to the Printer before performing this calibration.

- 1 In the Service Calibrations submenu, scroll to "2. Line Sensor cal" and press **Enter**.

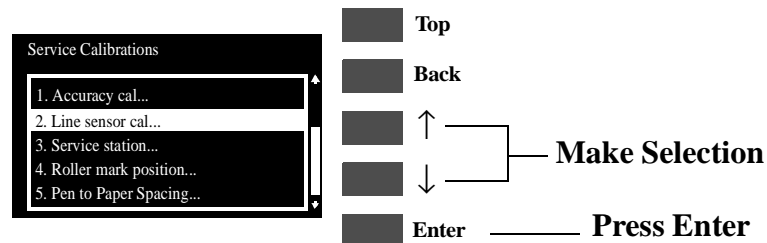

- 2 The following message will appear asking you to confirm the operation. Select **ACCEPT** if you want to continue the Line Sensor Calibration, or select **CANCEL** if you want to cancel the it. Press **Enter** once the selection has been made.

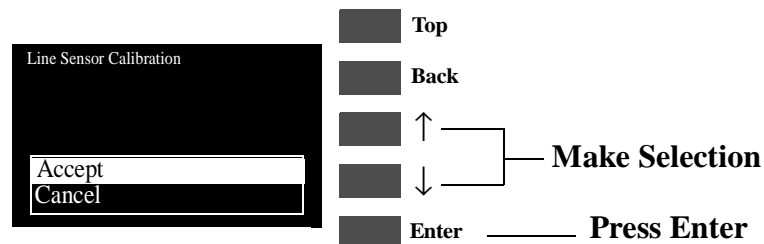

- If you selected to continue, then the following message appears on the front panel if media is not loaded. You must load Media in to the Printer to continue.

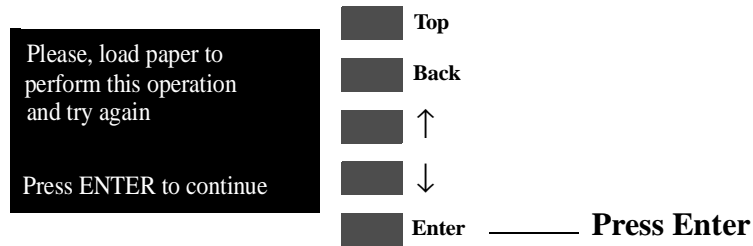

- The Printer will start to print the Line Sensor Pattern and the following message will be displayed on the front panel:

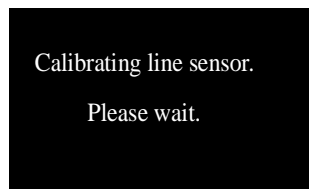

- Once the line sensor calibration is completed, the following message will be displayed on the front panel:

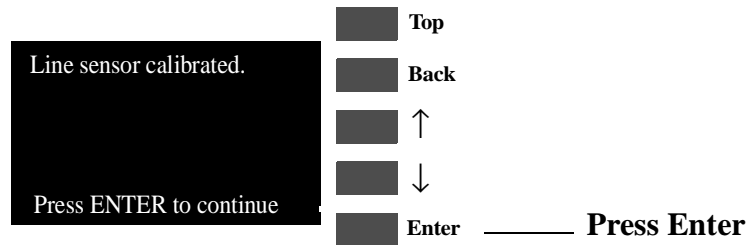

- To check if the Calibration was completed correctly, print the Service Configuration Print (see Page 1-19) and check that the values given for the LED (Green/Blue) are NOT zero.

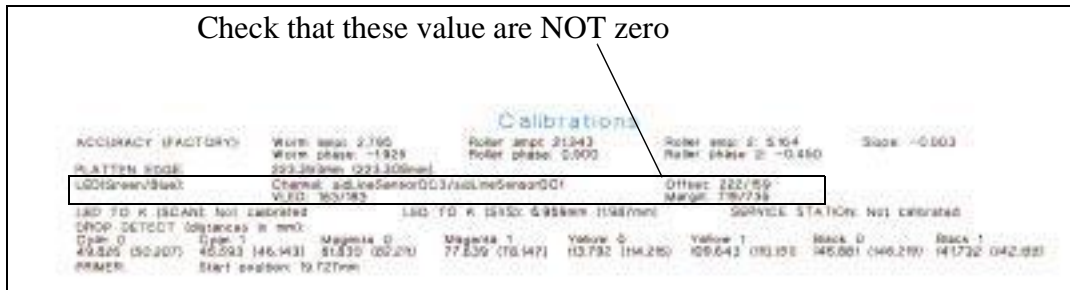

3. Service Station

The purpose of this Service Calibration is to calibrate the Service Station in relation to the Carriage Assembly.

Perform the Service Station Calibration whenever:

- Carriage Assembly is disassembled or replaced.
- Platen Assembly is disassembled or replaced.
- Service Station is disassembled or replaced.

Perform the Service Station Calibration as follows:

NOTE

Make sure you load media bigger than A4 in to the Printer before performing this calibration. Do NOT use any other type of media apart from HP Coated or HP High Gloss Photo Paper.

- 1 In the Service Calibrations submenu, scroll to "3. Service Station" and press **Enter**.

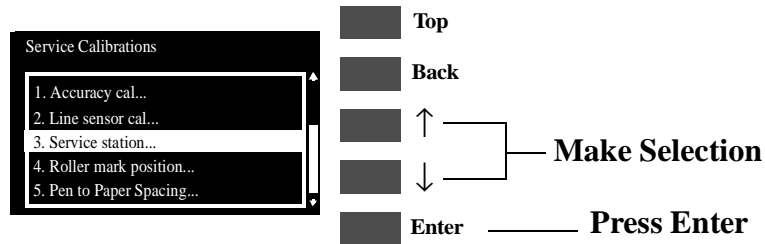

- 2 The following message will appear asking you to confirm the operation. Select **ACCEPT** if you want to continue the Service Station Calibration, or select **CANCEL** if you want to cancel the it. Press **Enter** once the selection has been made.

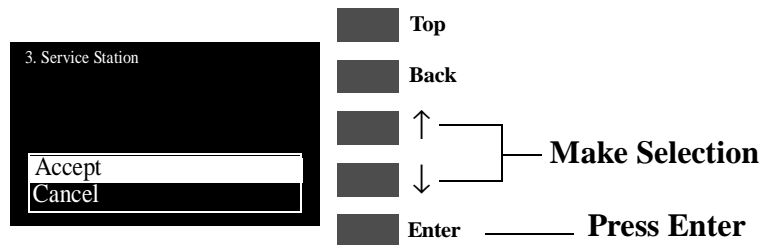

- If you selected to continue, then the following message appears on the front panel if media is not loaded. You must load Media in to the Printer to continue.

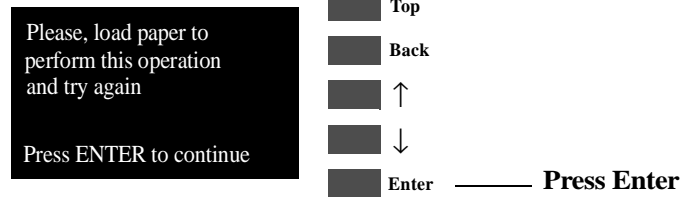

- The Printer will start to print the calibration pattern and the following messages will be displayed on the front panel:

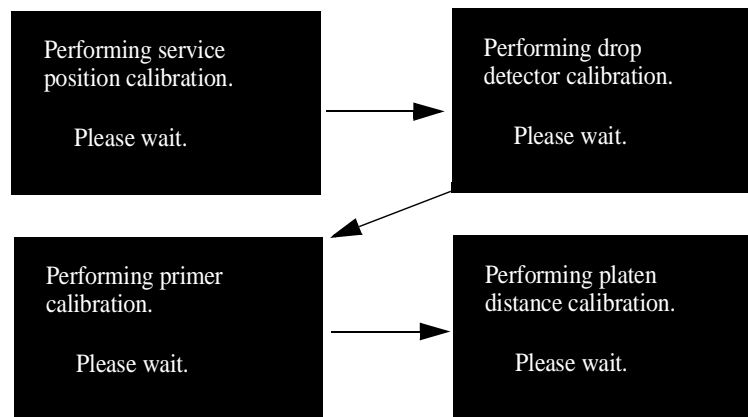

- Once the service station calibration is completed, the following message will be displayed on the front panel:

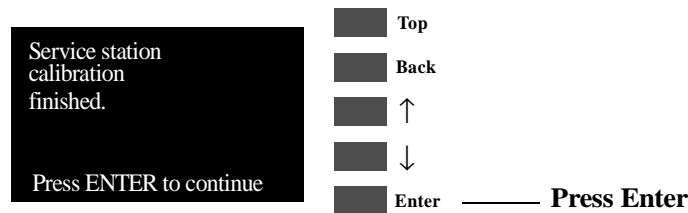

- To check if the Calibration was completed correctly, print the Service Configuration Print (see Page 1-19) and check that the calibrations are done and are within the stated limits.

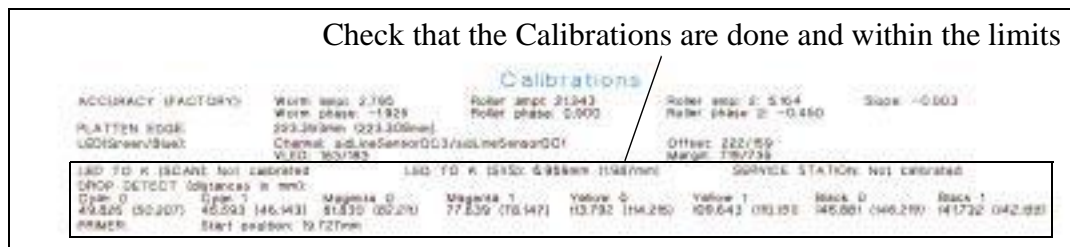

4. Roller Mark Position

The purpose of this Service Calibration is to calibrate the Mark Encoder which is located on the Drive Roller.

Perform the Roller Mark Position Calibration whenever:

- Carriage is disassembled or replaced.

Perform the Roller Mark Position Calibration as follows:

NOTE

Make sure that you unload the media from the Printer before performing this calibration.

- 1 In the Service Calibrations submenu, scroll to "4. Roller mark position" and press **Enter**.

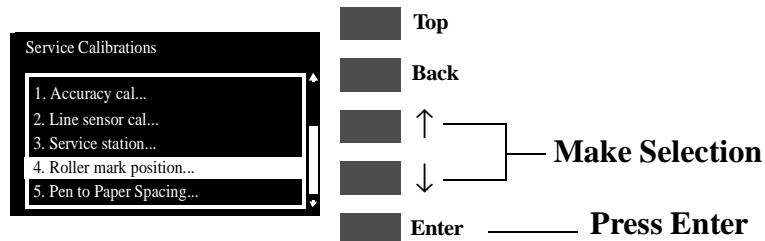

- 2 The following message will appear asking you to confirm the operation. Select **ACCEPT** if you want to continue the Roller Mark Position Calibration, or select **CANCEL** if you want to cancel the it. Press **Enter** once the selection has been made.

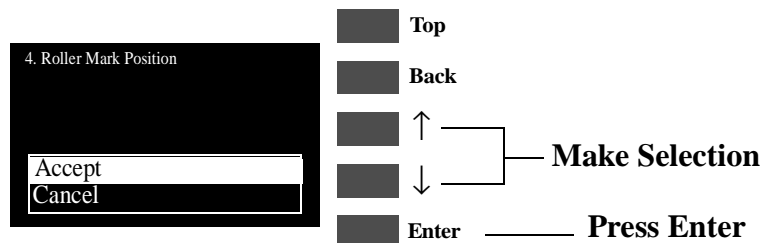

- 3 If you selected to continue, the calibration will start and the following message will appear on the front panel:

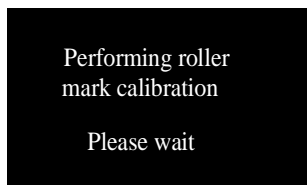

- 4 Once the roller mark position calibration is completed, the following message will be displayed on the front panel:

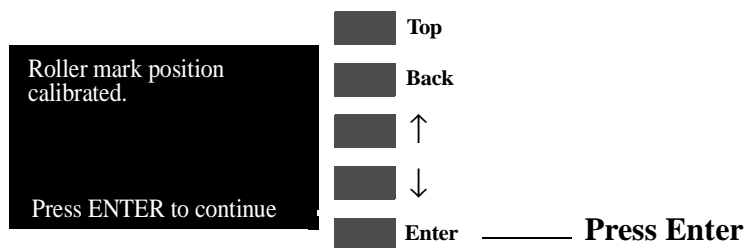

5. Pen to Paper Spacing

WARNING

THIS CALIBRATION IS NO LONGER REQUIRED AND SHOULD NEVER BE PERFORMED.

6. Color to Color calibration

The purpose of this Service Calibration is to correct the alignment between the Printheads and the rest of the Printer. This calibration is necessary in order to prevent color misalignment.

Perform the Color to Color Calibration whenever:

- Carriage is disassembled or replaced.
- Drive Roller is disassembled or replaced.
- Problems with color misalignment.
- Paper-Axis is disassembled or replaced.
- Platen Assembly is disassembled or replaced.
- Service Station is disassembled or replaced.

Perform the Color to Color Calibration as follows:

NOTE

Make sure that you load E/A0 size HP High Gloss Photo Paper or HP Coated media before performing this calibration. Do NOT use any other type of media apart from HP Coated or HP High Gloss Photo Paper.

- 1 In the Service Calibrations submenu, scroll to "6. Color to Color cal" and press **Enter**.

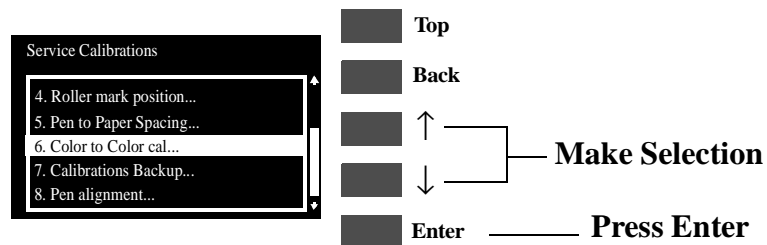

- 2 The following message will appear asking you to confirm the operation. Select **ACCEPT** if you want to continue the Calibration, or select **CANCEL** if you want to cancel the it. Press **Enter** once the selection has been made.

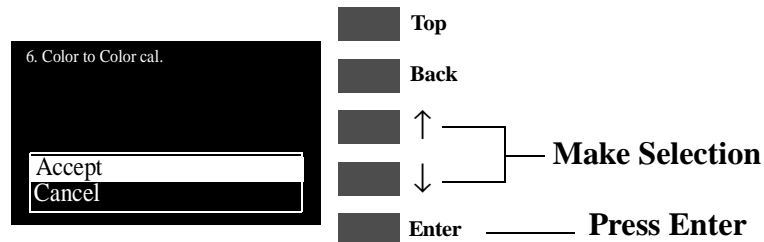

- If you selected to continue, then the following message appears on the front panel if media is not loaded.

NOTE

Make sure that you load E/A0 size HP High Gloss Photo Paper or HP Coated media. Do NOT use any other type of media apart from HP Coated or HP High Gloss Photo Paper.

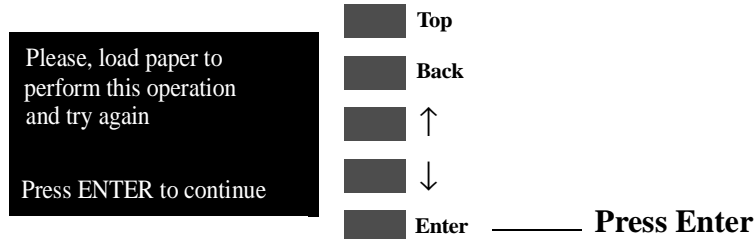

- The Printer will start to print the calibration pattern and the following message will be displayed on the front panel:

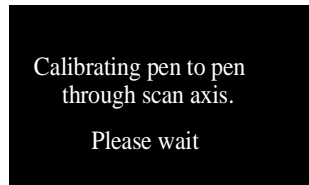

- Once the pen to paper spacing calibration is completed, the following message will be displayed on the front panel:

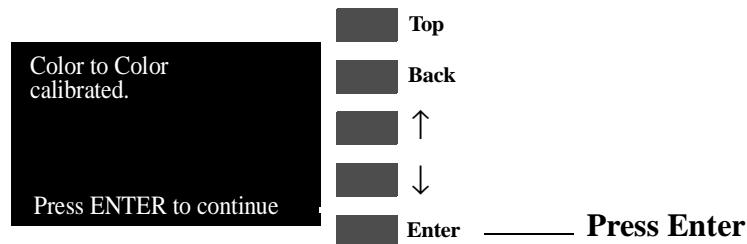

NOTE

Make sure that you press Form Feed and Cut when you have finished the calibration to trim the calibration pattern from the media roll.

If the calibration fails, then the following message will appear on

the front panel:

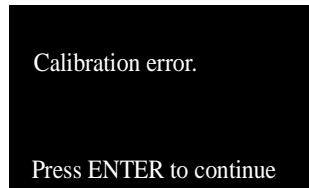

In this case, to resolve the problem, try the following:

- 1 *If the calibration pattern is bad:*
 - Try recovering the Printheads using the front-panel menu and try the calibration again.
 - If the calibration pattern is bad again, then replace the Printhead of the color that is bad.
- 2 *Perform the Electronics System test ⇒ Page 4-5.*

7. Calibrations Backup

The purpose of this Service Calibration is to allow the EEROM contents to be saved when the Electronics Module or the Tubes System has been replaced.

WARNING

ALWAYS PERFORM THE CALIBRATIONS BACKUP AFTER REPLACING THE ELECTRONICS MODULE OR THE TUBES SYSTEM.

Perform the Calibrations Backup as follows:

- 1 In the Service Utilities submenu, scroll to "7. Calibrations Backup" and press **Enter**.

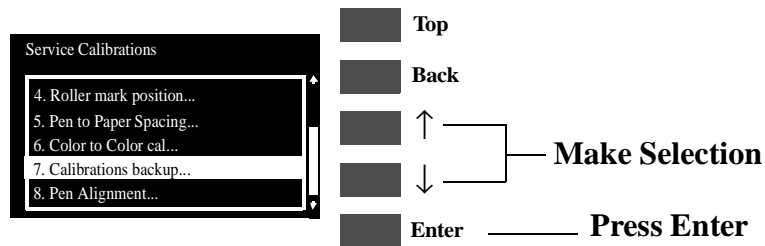

- 2 When the following message appears on the front panel, you must select which component you have replaced. Select either the Electronics Module or Tubes System and press **Enter**.

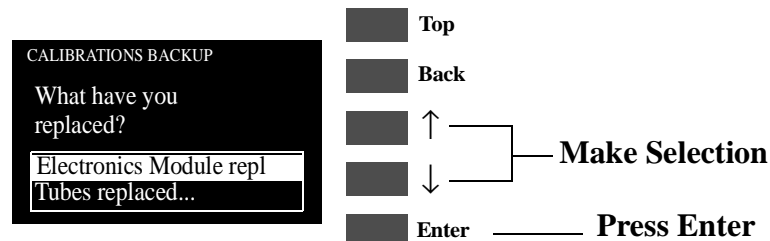

If the Electronics Module was replaced

- a If the Electronics Module was replaced, then select Electronics Module and press **Enter**.

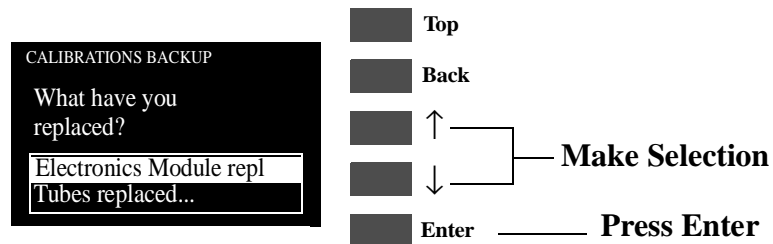

- b The following message will appear asking you to confirm the operation. Select **ACCEPT** if you want to continue the Calibrations Backup, or select

CANCEL if you want to cancel the Calibrations Backup. Press **Enter** once the selection has been made.

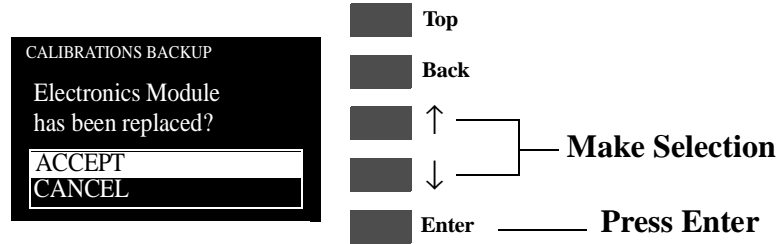

- c If you selected to continue, the Calibrations Backup will start to update the calibrations and the following message will be displayed on the front panel:

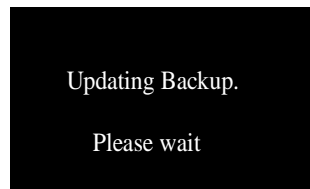

- d Once the Calibrations Backup has been completed the following message will appear on the front panel:

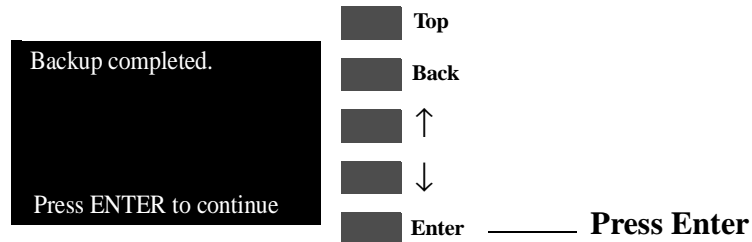

If the Tubes System was replaced

- a If the Tubes System was replaced, then select Tubes System and press **Enter**.

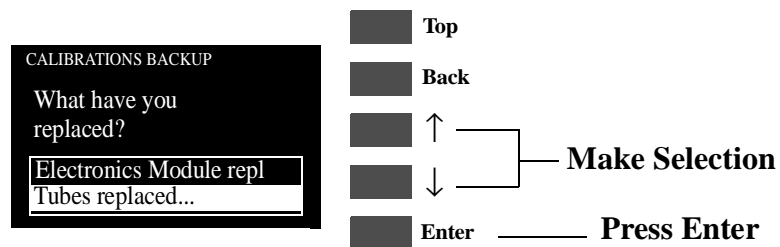

- b The following message will appear asking you to confirm the operation. Select **ACCEPT** if you want to continue the Calibrations Backup, or select

CANCEL if you want to cancel the Calibrations Backup. Press **Enter** once the selection has been made.

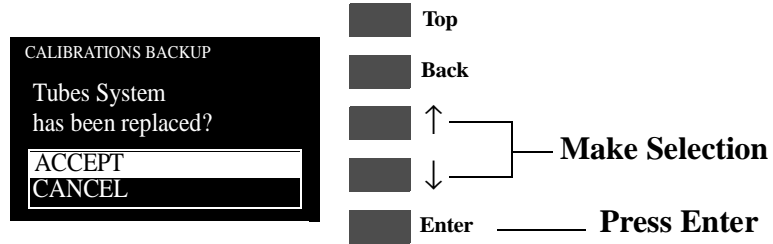

- c If you selected to continue, the Calibrations Backup will start to update the calibrations and the following message will be displayed on the front panel:



- d Once the Calibrations Backup has been completed the following message will appear on the front panel:

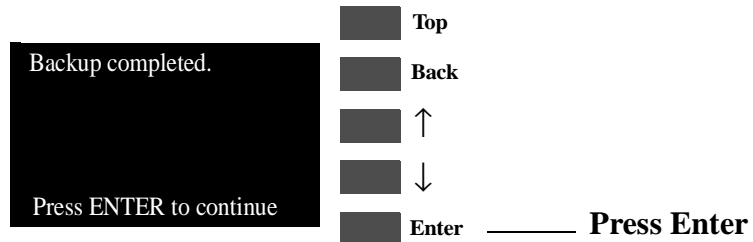

8. Pen Alignment

The purpose of this Service Calibration is to correct the alignment between the Printheads. This calibration is necessary in order to prevent color misalignment and print quality defects like banding.

Perform the Printhead Alignment Calibration whenever:

- Carriage is disassembled or replaced.
- Tubes System is disassembled or replaced.
- Banding is detected in prints.
- Misalignment between colors is detected
- Electronics Module is replaced.

Perform the Pen Alignment Calibration as follows:

NOTE

Make sure you load media before performing this calibration.

WARNING

Do NOT use Clear Film, Vellum or Natural Tracing Paper.

- 1 In the Service Calibrations submenu, scroll to "8. Pen Alignment" and press **Enter**.

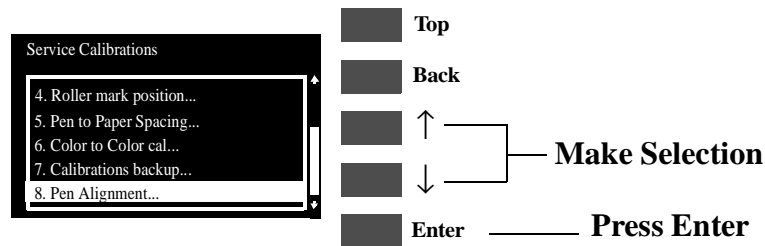

- 2 The following message will appear asking you to confirm the operation. Select **ACCEPT** if you want to continue the Calibration, or select **CANCEL** if you want to cancel the it. Press **Enter** once the selection has been made.

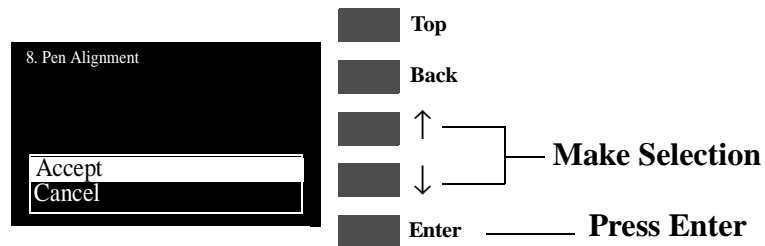

- 3 If you selected to continue, then the following message appears on the front panel if media is not loaded. You must load Media in to the Printer to continue.

WARNING

Do NOT use Clear Film, Vellum or Natural Tracing Paper.

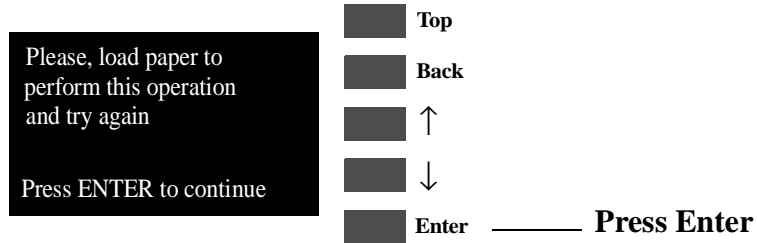

- 4 The Printer will start to print the Alignment Pattern and the following message will be displayed on the front panel:

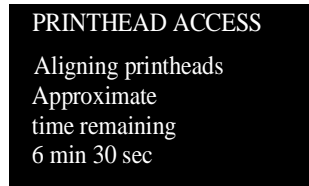

- 5 Once the Pen Alignment calibration is completed, the following message will be displayed on the front panel:

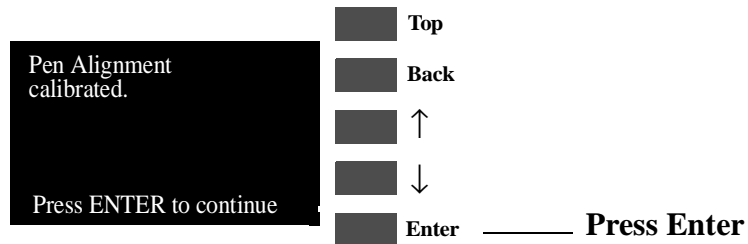

- 6 If the calibration fails *Perform the Electronic Systems Test* ⇒ Page 4-5.

Carriage Height Calibration

The purpose of this Service Calibration is to adjust the distance between the Carriage Assembly and the Center Platen. This calibration is necessary in order to prevent problems like Printhead crashes.

Perform the Carriage Height Calibration whenever:

- Carriage is disassembled or replaced.
- Center Platen is disassembled or replaced.
- Continuous Printhead Crashes.

Perform the Carriage Height Calibration as follows:

NOTE

The procedure should be carried out using the Carriage Height Tool (See Figure 1 below) that came with the new Carriage Assembly or Center Platen Assembly.

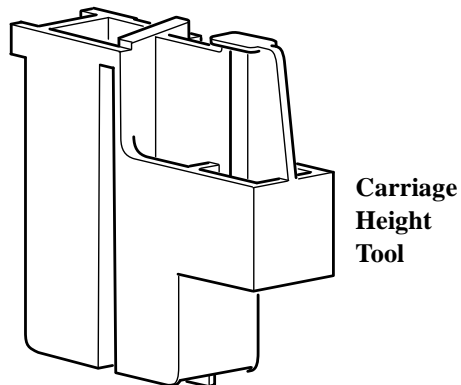
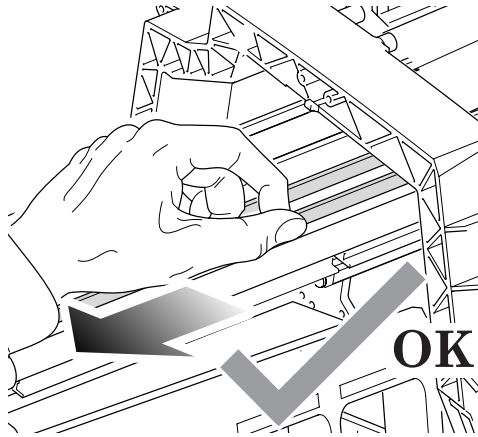

Figure 1

NOTE

During the Carriage Height Calibration procedure the Carriage Assembly has to be moved along the length of the printer for correct calibration. Make sure that the Carriage Assembly is only ever moved by pulling the belt and never by direct contact with the carriage itself (See Figure 2 below).



Correct: move using the belt.

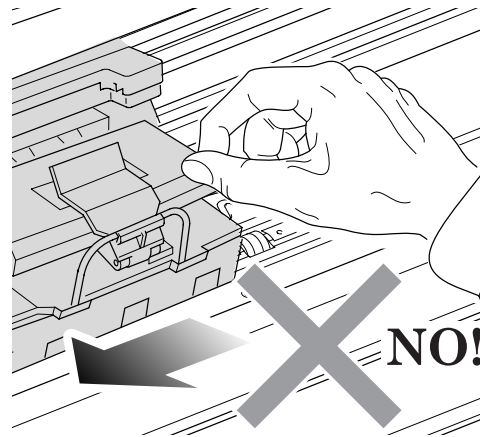

Incorrect: never move using Carriage Assembly.

Figure 2

- 1 Disconnect the Ink Leak Detector Cable Connector from the back of the printer.

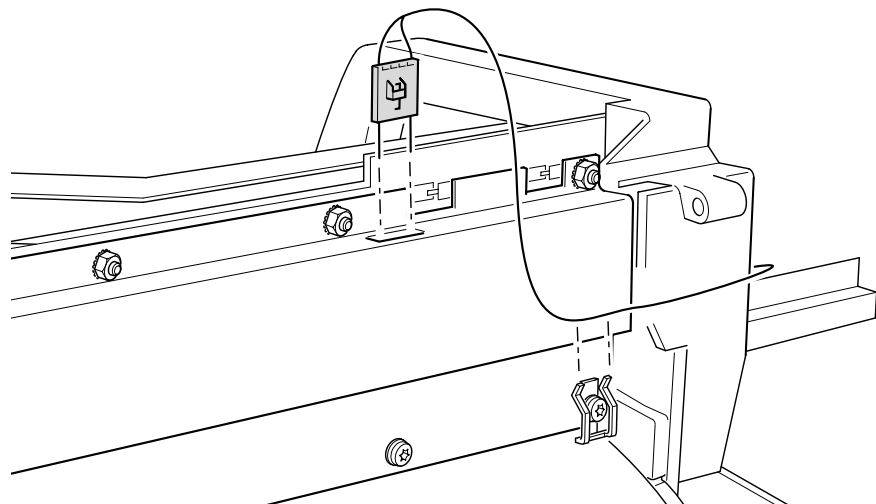

- 2 Remove the EMC Cover on the left hand side of the printing area.

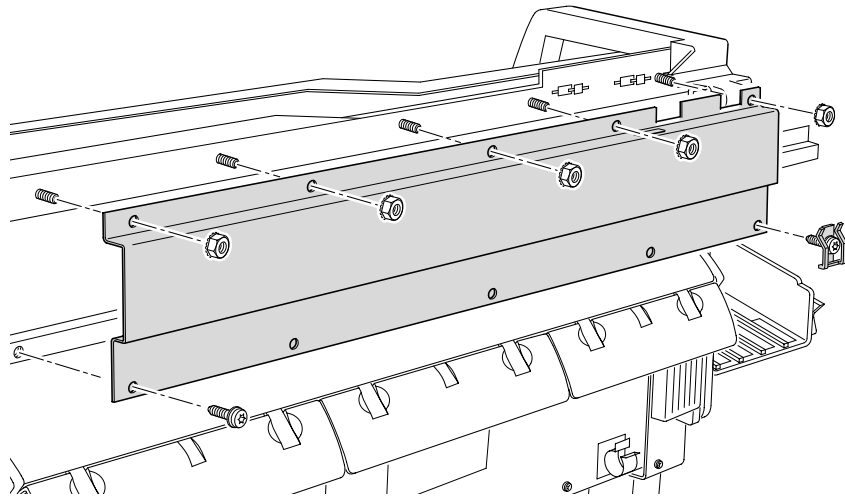

- 3 Open the Carriage Cover on the left hand side of the printing area.

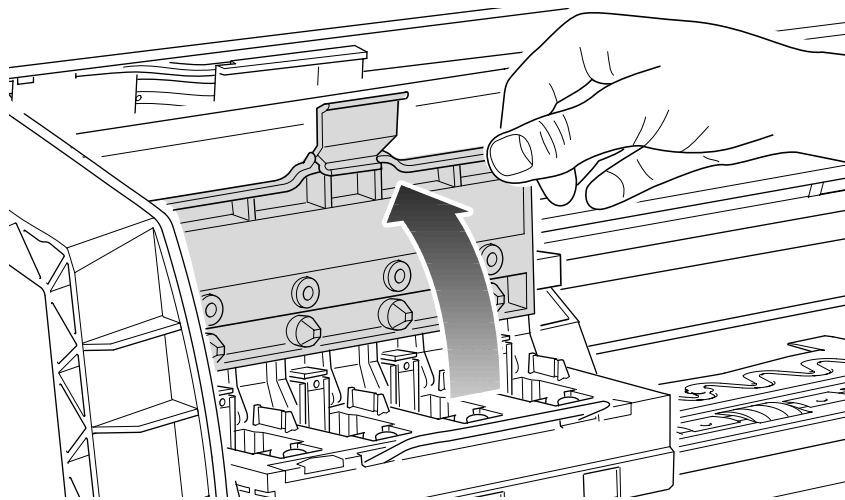

- 4** Insert the Carriage Height Tool into the black cartridge slot.

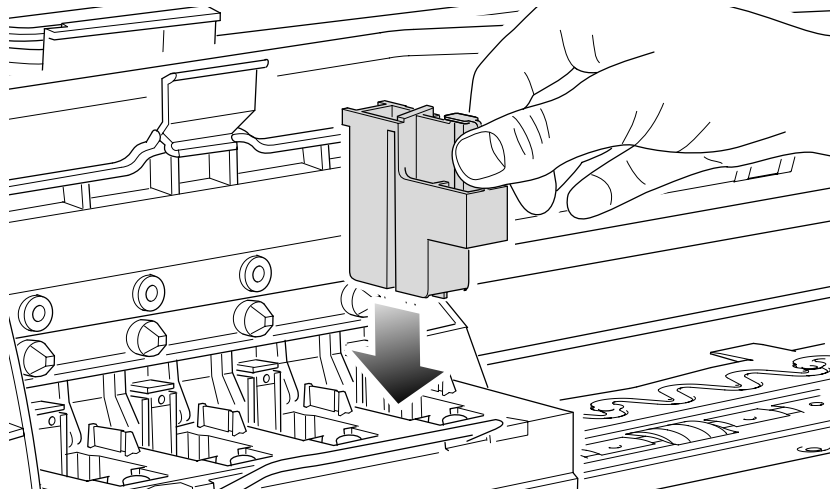

- 5** Close the Carriage Cover

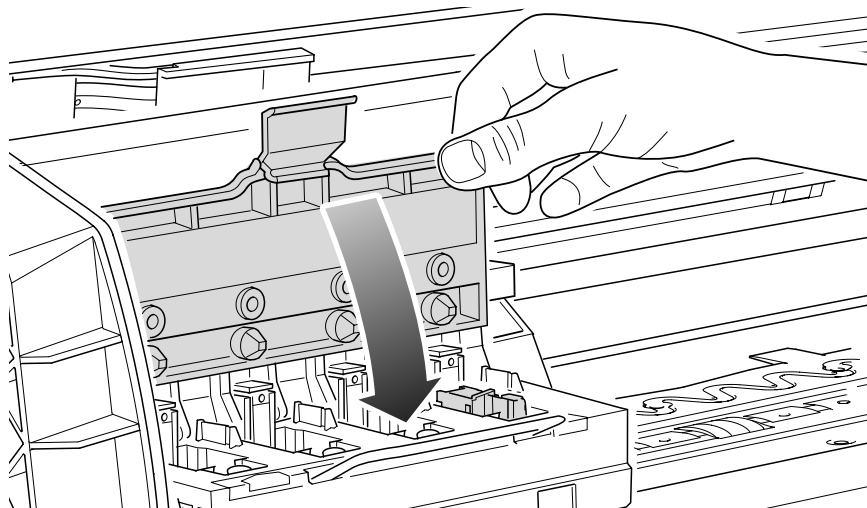

- 6 Loosen the two T10 screws at the back of the Carriage Assembly.

NOTE

NOTE: The screws should not be removed.

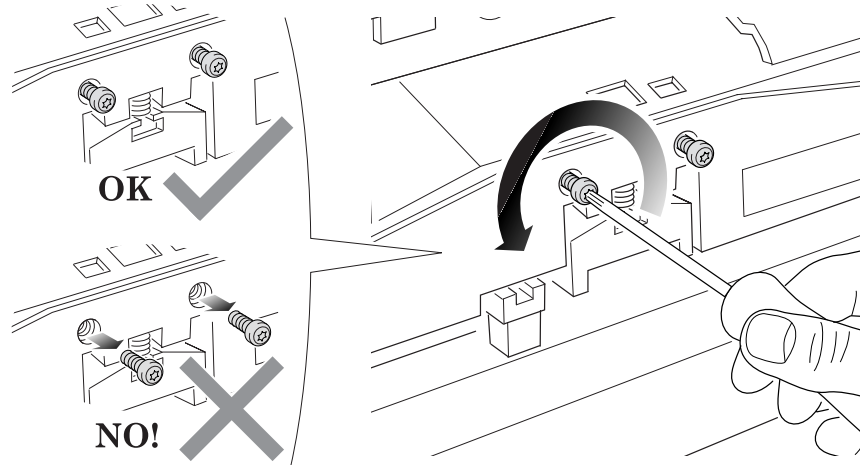

- 7 Using the belt, and beginning to the left hand side of the starting position (where the left hand edge of the paper is positioned when printing), move the Carriage Assembly back and forth along the length of the printer, **you are listening for a scraping sound**: if you hear a sound already you may proceed directly with step 9, if not you must lower the Carriage Assembly (step 8), and try again until a scraping sound is heard.

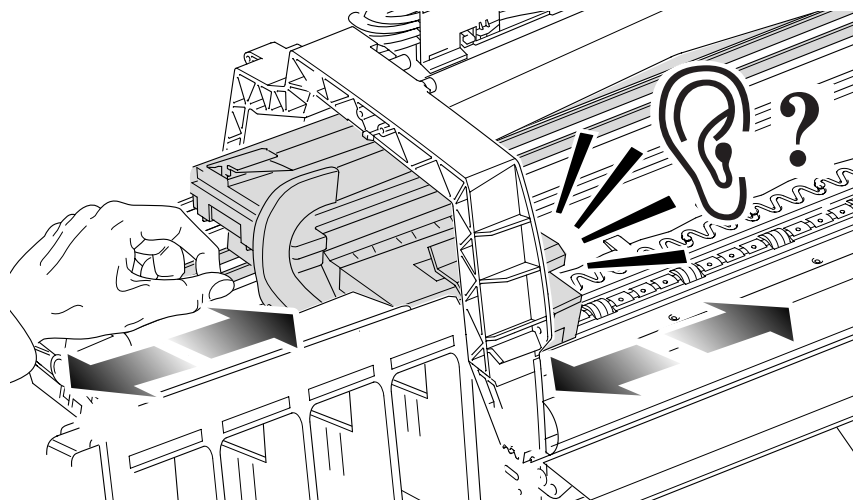

- 8** Lower the Carriage Assembly slightly, by turning the T9 screw shown below anti-clockwise and then check for a scraping sound again as shown previously in step 7.

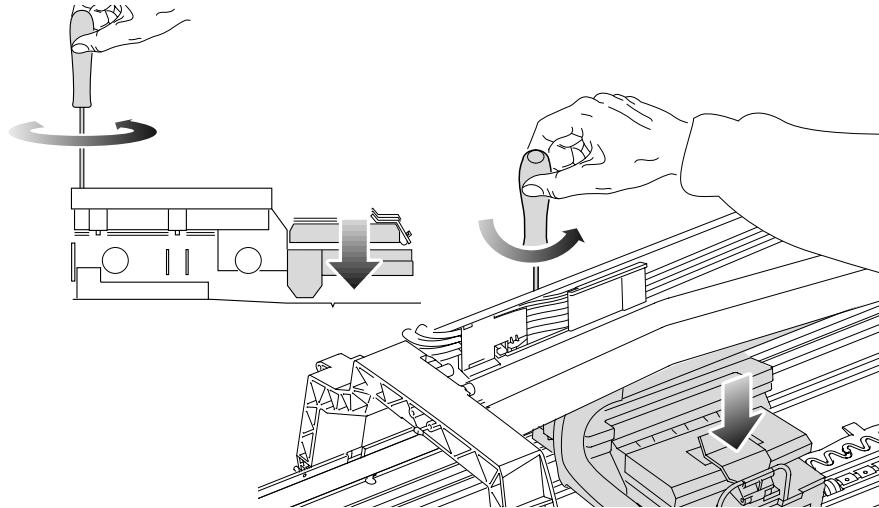

- 9** On moving the Carriage Assembly along the length of the printer you should now hear a scraping sound: this sound indicates that you need to raise the Carriage Assembly (if there is no sound repeat step 8).

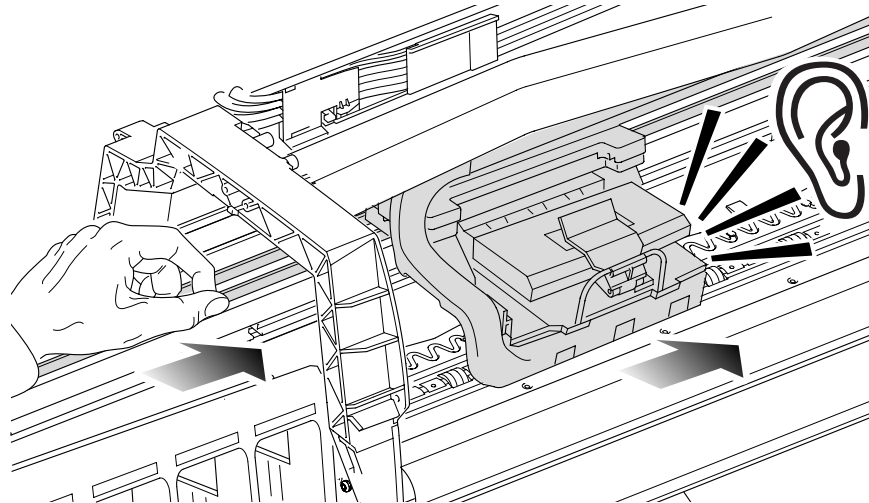

- 10** Raise the Carriage Assembly slightly, by turning the T9 screw (shown below) clockwise

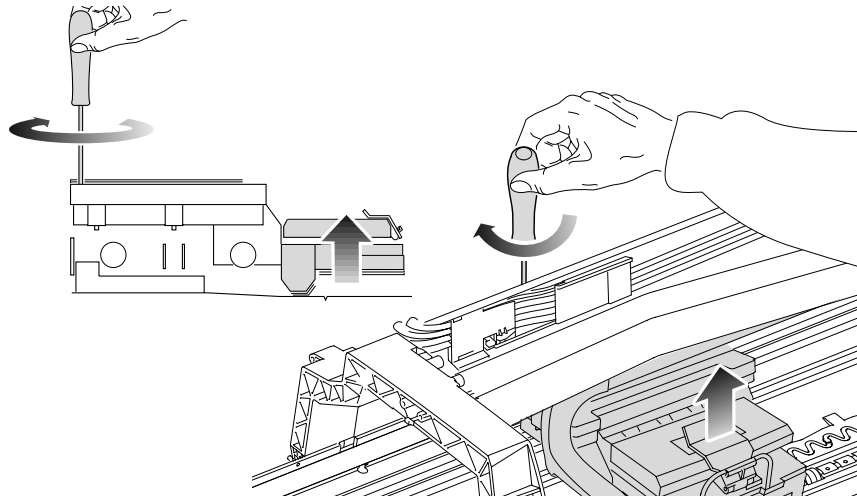

- 11** Check that there is no longer a scraping sound.

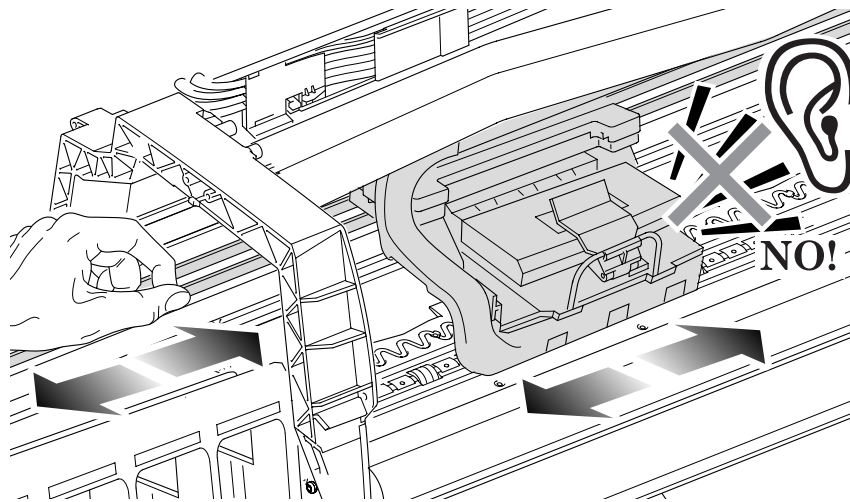

- 12** When the scraping has been eliminated it is important to leave the Carriage Assembly as close as possible to the Center Platen: move the Carriage Assembly back and forth across the area where the scraping sound was, gently lowering and raising the Carriage Assembly until you are sure that it is as close as it possibly can be to the Center Platen without touching.

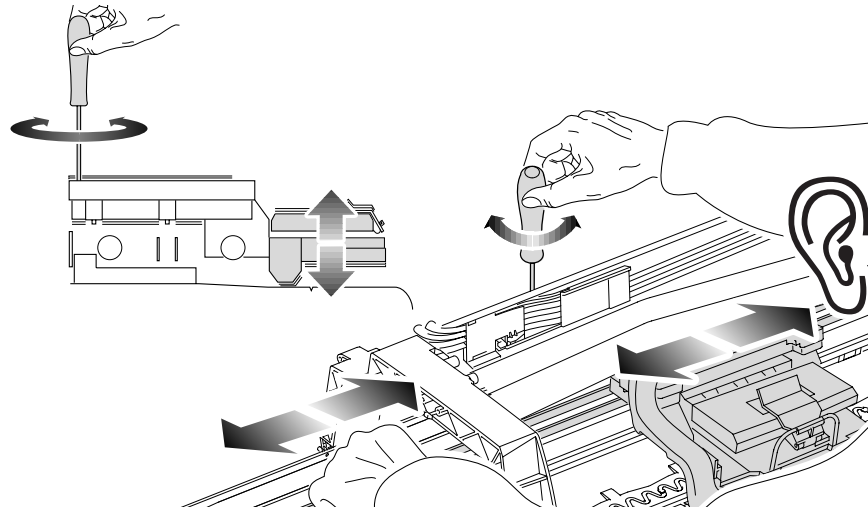

- 13** Continue checking the full length of the printer until you arrive at the blue line used to load the cut sheet paper, repeating steps 10, 11 and 12 whenever a scraping sound is heard.

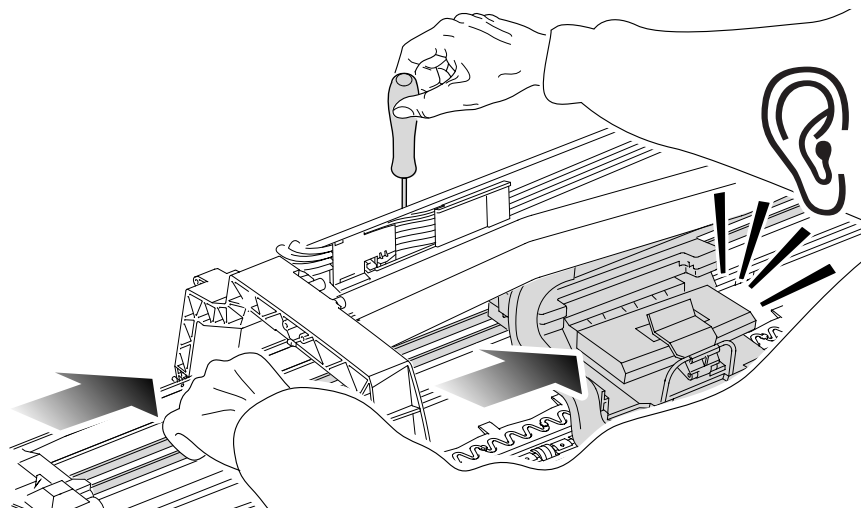

- 14** When the complete length of the printer is calibrated (clear of any scraping sound), tighten the two T10 screws at the back of the Carriage Assembly to secure the current position.

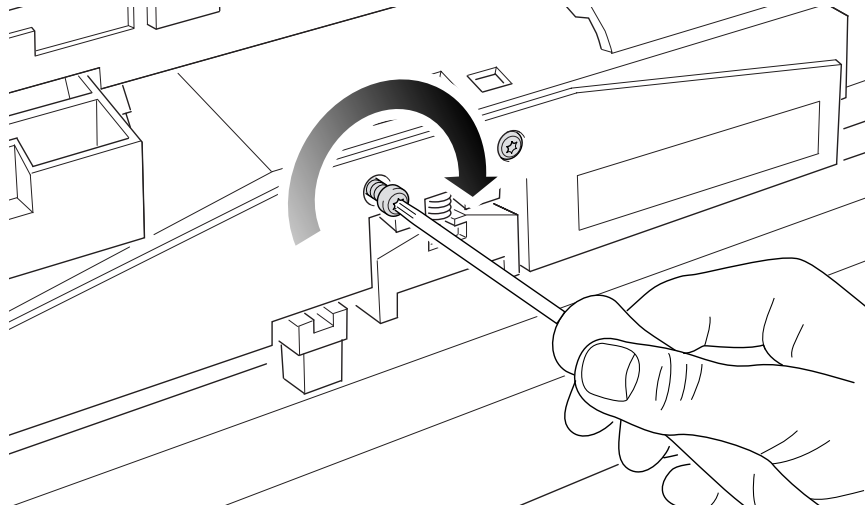

- 15** Remove the Carriage Height Tool.

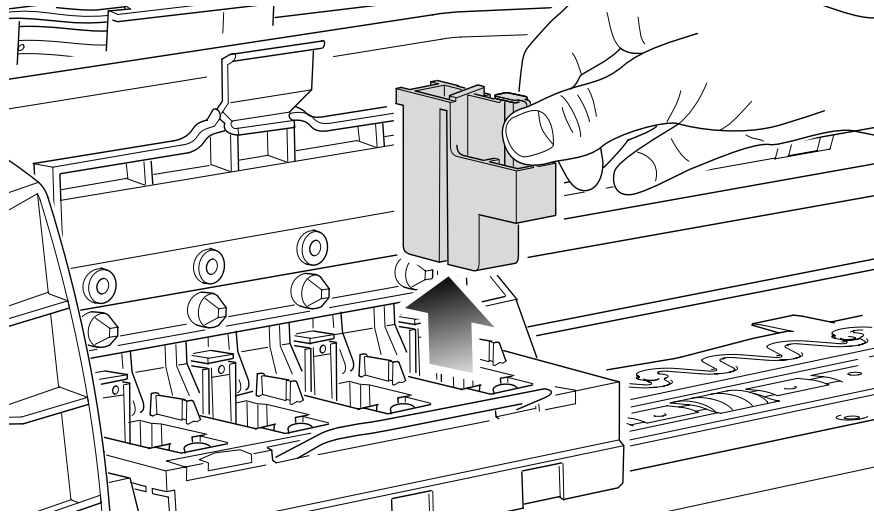

Print Quality

6

- Print Quality 6-2
 - Print Quality Troubleshooting Checklist 6-2
 - Print Modes 6-3
- How to Use the Print Quality Test 6-4
 - What is the Print Quality Test? 6-4
 - Printing the Print Quality Test 6-4
 - Nozzle Print Test 6-6
 - Color Alignment Print Test 6-7
 - What is Banding? 6-9
 - Aligning the Printheads 6-12
- Troubleshooting Print Quality Problems 6-13
 - Problems with Stepped Lines 6-13
 - Long Term Color Bleeding (Glossy Papers) 6-22
 - Color Consistency problems 6-22
 - Color Accuracy Configuration 6-23
 - There are Smears or Scratching on the Printed Media 6-24

Print Quality

Print Quality Troubleshooting Checklist

When faced with an Print Quality problem, use the following checklist as a guide in troubleshooting the problem:

- 1 Problem reproduction**
 - Reproduce the problem that the customer is seeing using their original settings.
- 2 Printer configuration:**
 - Print Mode: Set to "Best" (in the printer and in the drivers).
 - Dry time: Set to "Automatic".
 - Select the correct media setting when loading the media.
- 3 Hardware check list**

Firmware Revision

 - Check if the latest version of the firmware is installed. If not Install the latest firmware revision. Refer to Chapter 7 for the part number of the Flash SIMM.
- 4 Printheads**

Printhead Troubleshooting Process:

 - If you don't have any samples yet, reproduce the original problem with the correct printer settings.
 - Print the Print Quality Test using the exact settings and Media that the Customer used when faced with the Print Quality problem

Printhead Alignment and Check:

 - Perform the Printhead Alignment using HP High-Gloss Photo Paper. If not available, use Coated media if required.
- 5 Media**
 - Make sure that you use HP or HP-approved media.
 - Select the correct media type through the front-panel when loading it.
- 6 Driver print quality configuration:**

To clarify if the reason of the problem is related with the print mode defined with the Non-HP Driver try the following:

 - Print the same sample using the Non-HP driver and their normal media.

-
- Print one of the internal demos or print the Print Quality Test using HP Media and configuring the printer as indicated previously.
 - If the output obtained using the HP Solution is good and the one obtained through the 3rd party solution is bad, HP support organization should:
 - Communicate to the customer that the problem is not in the printer and that he should address it through the 3rd party vendor support structure.
- 7 Service Accuracy Calibration
- Perform "Service Accuracy calibration" using HP High-Gloss Photo Paper.

WARNING

Do NOT use any other type of media apart from HP High Gloss Photo Paper when performing the Accuracy Calibration.

Print Modes

The Printers have a large number of print modes. A print mode specifies how to interpret and put on media a set of bitmap planes, each of which consists of a sequence of rows. Each mode corresponds to a unique combination of the following parameters:

- Print resolution (300 dpi, 600 dpi, 1200 x 600 addressable).
- Number of passes per advance.
- Number of advances per swath.
- Print direction (bidirectional).
- Carriage speed.
- Smart Area Fill (SAF).
- Print masks.
- Servicing states.
- Multiple dotting (K).

User input to print mode selection consists of the following:

- Choice of media type.
- Choice of print-quality setting (fast, normal, best).
- The language in which the file is received.
- The model of printer used.
- The type of driver (HP or Non-HP).

How to Use the Print Quality Test

What is the Print Quality Test?

The Printer contains an internal Print Quality Test which helps you to diagnose the possible source of any print quality defects. The Print Quality Test is divided into three parts:

- a Nozzle print test, designed to check if the printhead nozzles print correctly.
- b Color alignment test, designed to check any color-to-color misalignment the printer may have.
- c Overall print quality in **BEST** mode, specifically designed to diagnose banding problems in high density areas.

Considerations for Printing the Print Quality Test.

- 1 The Print Quality Test prints in A3 and B sizes so you must have media loaded (roll or sheet) that is this size or larger.
- 2 Use the same type of media that the customer was using when they found the print quality problem.
- 3 If the customer is using non-HP media and after the Print Quality Test you still have the same print quality problems, change to genuine HP media and repeat the Print Quality Test.
- 4 If you do not see any problems with the Print Quality Test, then the problem may not be with the printer itself. The problem may be with the RIP or the driver for example.

However if you do see problems with the Print Quality Test then continue with the following procedures which will help you to diagnose the problem.

Printing the Print Quality Test

- 1 Go to the printer submenu and press **Enter**.



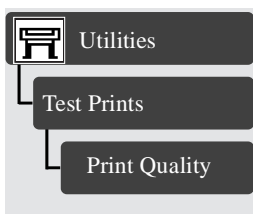

- 2 Select Print Quality from the Utilities/Test Prints menu, then press **Enter** to print the test.

The printer will print out a series of patterns (shown below):

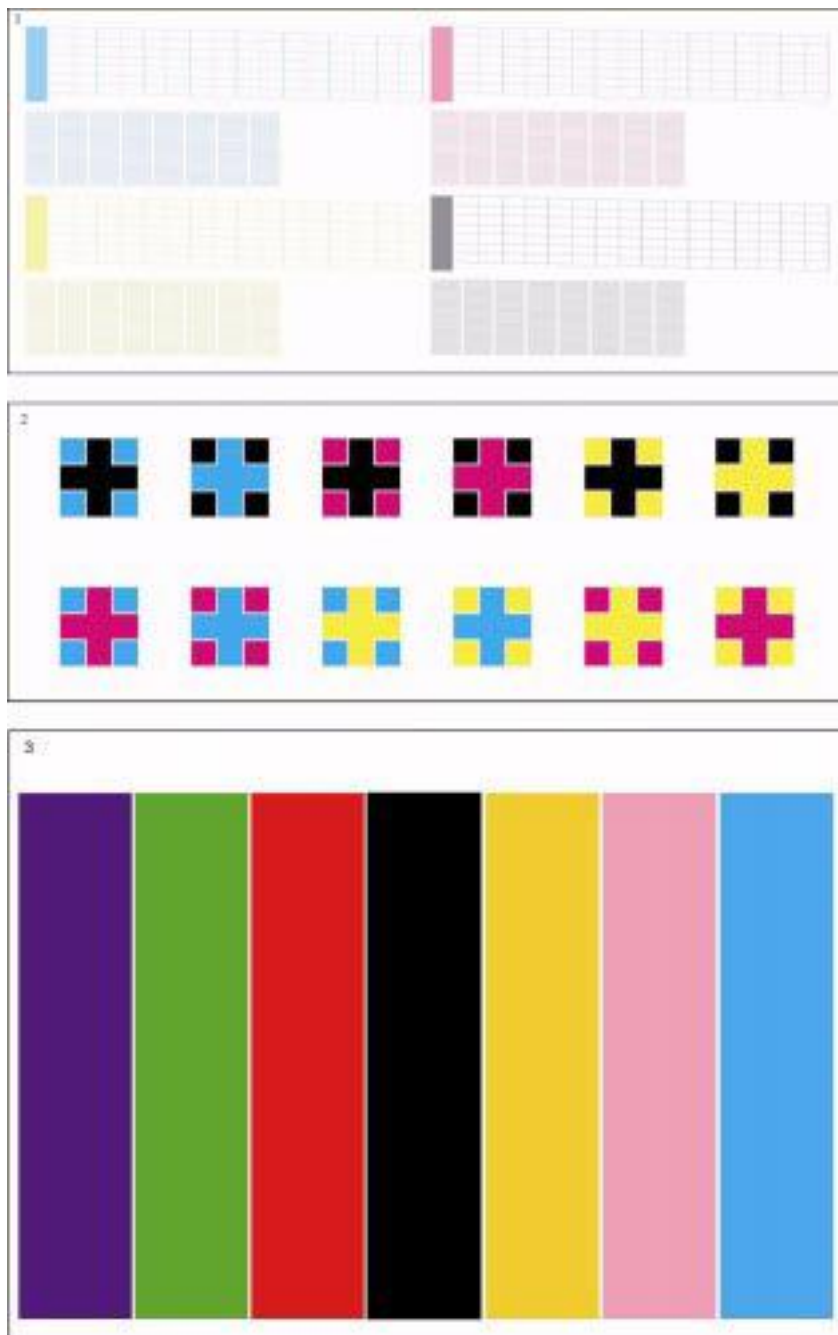

Nozzle Print Test



The nozzle print test is located on the Print Quality Test in the top section. In this test the 512 nozzles that each printhead uses to print with are tested.

This is what you would see if there are nozzles not printing correctly:

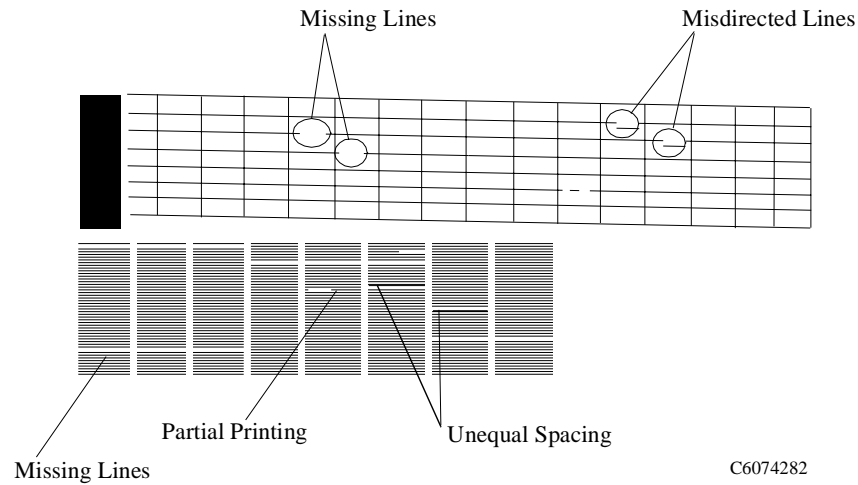

- 1 In the top pattern of the Print Quality Test, there is a series of stepped diagonal lines. If one or more of the nozzles are malfunctioning or mis-positioned, you will see that the stepped lines are broken or misdirected in one or more places.
- 2 Below the top pattern on the Print Quality Test, there is a series of horizontal straight lines. If one or more nozzles are misdirected there will be unequal spaces between the corresponding lines.

How to fix the Nozzle Defects

NOTE

If your printer has nozzle defects, it does not mean that you will not get perfect print quality results. The printer has automatic procedures to hide many nozzle defects. This type of problem affects mostly Normal and Draft modes.

- 1 Go to the Printer submenu and press **Enter**.

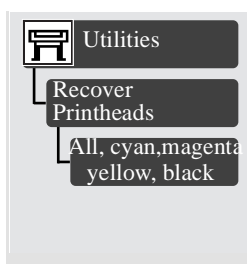

- 2 Go to the Utilities/Recover Printheads.
- 3 Select the printhead color that is responsible for the problem. The printer will try to 'Recover' the defective printhead. If you are not sure which printhead color is giving you the problem select all of the printheads. Please wait as the process of recovery takes a few minutes.
- 4 Reprint the Print Quality Test to check that the defective nozzles have been corrected.
- 5 If the error is still present, replace the worst printheads.

Color Alignment Print Test

This part of the Print Quality Test is designed to check the color alignment. It produces twelve patterns each with two different primary colors. In each pattern you will see a cross surrounded by another color. If there is misalignment between the colors there will be inconsistent spacing between the cross and the other color.

There are two types of misalignment:

- Horizontal - when the misalignment is in the horizontal axis.
- Vertical - when the misalignment is in the vertical axis.

Below are shown two examples of alignment and misalignment:



correct



Incorrect

C6074276

Solving the Color Alignment Problem

- 1 Make sure you have media loaded (not clear film, vellum or tracing paper).
- 2 Go to the printer submenu and press **Enter**.

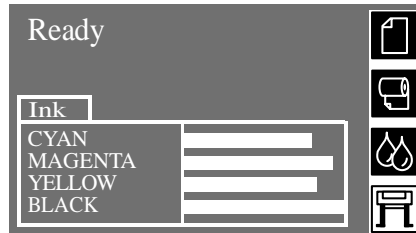

Printer submenu

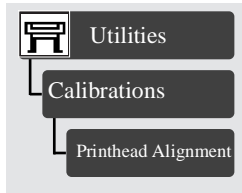

- 3 Perform the Printhead Alignment Calibration by going to Utilities/Calibration/Printhead Alignment. Please wait as the process of aligning the printheads takes a few minutes.
- 4 Reprint the image you were attempting to print before (in the same mode) to see if the problem still exists.
- 5 Perform the Color to Color Calibration ⇒ Page 5-16.

Overall Print Quality Test in BEST mode

Blue, Green, Red, Black, Yellow, Magenta, Cyan Test

This test pattern checks performance for banding in **Best** mode only for the media you are using.

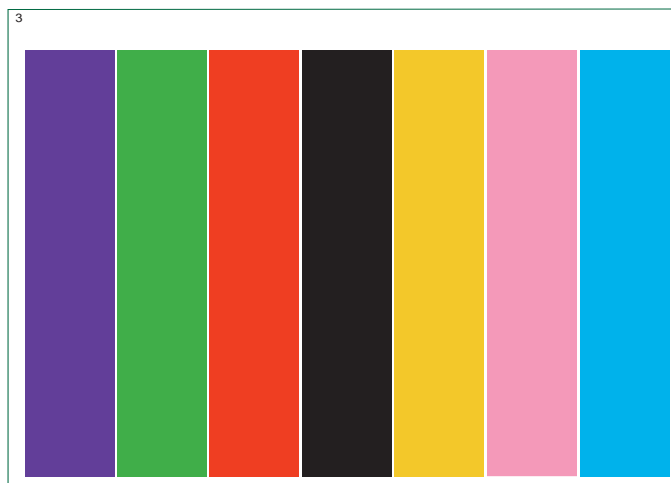

C6074279

What is Banding?

Banding is when you see repetitive horizontal bands within your printed image (these may appear as light or dark bands).

The test pattern is printed with four primary colors; black, cyan, magenta and yellow. The three secondary colors printed are red, blue and green and they are formed by mixing the primary colors as shown in the table below:

Secondary Color	Primary Color Components
Red (R)	Magenta (M) and Yellow (Y)
Blue (B)	Magenta (M) and Cyan (C)
Green (G)	Cyan (C) and Yellow (Y)

Solving the Banding Problem

There main causes of banding:

- Printhead problems (*see below*).
- Use of Non-HP media
- Incorrect media type selected in the front panel.
- Media advance problems.

Banding Caused by Printhead Problems

In this case you will see banding in only a few colors.

If the test pattern has clear or dark horizontal bands in one or more of the primary color columns, then several of the secondary color columns will also have the same type of bands in the same position (but perhaps with less intensity).

In the following example, several nozzles in the magenta printhead are not printing. There will be clear repetitive bands (perhaps white) in the magenta column. Consequently, you will see lower intensity bands in the same print position in the red (which is Magenta + Yellow) and blue (which is Magenta + Cyan) of the secondary color columns.

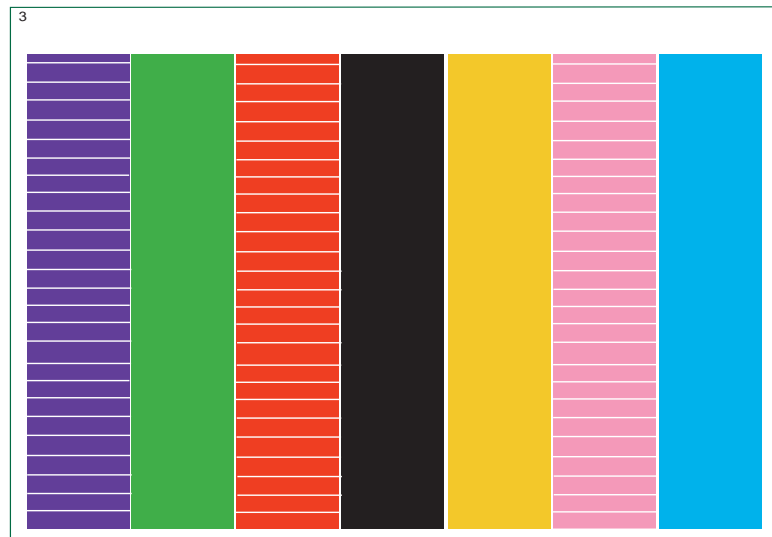

C60742

- 1 The bands could be caused by the nozzles not printing correctly. You can check the health of the nozzles by performing the Nozzle Print Test.

- 2 The light or dark horizontal lines could also be caused by permanently damaged printheads. The possible combinations with this problem are:
- Banding in **cyan, blue** and **green** columns only, but more evident in cyan. This means that the cyan printhead could be permanently damaged.
 - Banding in **magenta, red** and **blue** columns only, but more evident in magenta. This means that the magenta printhead could be permanently damaged.
 - Banding in **yellow, red** and **green** columns only, but more evident in yellow. This means that the yellow printhead could be permanently damaged.
 - Banding in **black** column only. This means that the black printhead could be permanently damaged.

If you want the best high quality image from your printer, replace the damaged printhead with a new one.

NOTE

However, your printer can still produce good quality line prints.

Banding Caused by Media Advance Problems

Another type of banding is caused by an inaccurate media advance in this case there will be banding (horizontal repetitive bands along the test pattern) in **all** the primary and secondary color columns.

The bands can appear as dark bands, due to a shorter advance of the roller which causes an overlap, or lighter bands due to a longer advance causing spaces.



C6074281

Banding in all of the colors

- 1 Make sure that the media selection made in the front panel is the same as the media that you have loaded.
- 2 It is possible that the banding was caused because the customer was using non-HP media. If the customer still wants to use non-HP media, recalibrate the paper accuracy by performing the accuracy calibration. Performing this will overwrite the default setting for **only** the paper that you have selected.

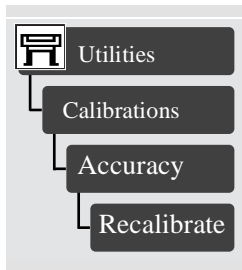

NOTE: If the customer wants to use HP certified paper at a later stage, they can restore the optimal setting to what it was by going to Utilities/Calibration/Accuracy/Restore Factory.

- 3 Perform the printheads alignment procedure.

Aligning the Printheads

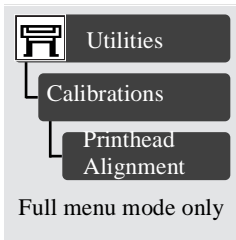

The printhead alignment selection causes the printer to align the printheads immediately, or if an image is being printed, as soon as the current print job is finished. The alignment procedure requires a minimum paper size of A2 or C-size.

The printer will automatically perform an alignment when printheads are replaced. You can use this feature if the Print Quality Print indicates an alignment error.

NOTE

You should not attempt to align the printheads with tracing paper, vellum or clear film.

Service Accuracy Calibration

If the banding problem remains after using HP Media and trying the above steps to resolve the problem, perform the Service Accuracy Calibration ⇒ Page 5-6.

Troubleshooting Print Quality Problems

Problems with Stepped Lines

Description of problem

When you look at the image you have printed there are ‘**stepped lines**’ in the borders of arrows and diagonal lines. The lines should be straight with no stepping.

Shown below is an example of what you might see if you have problems with Stepped Lines.

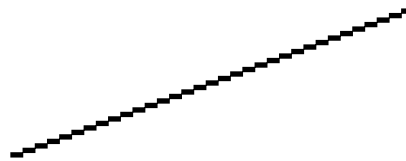

C6074283

How to solve the problem

- 1 Increase the dpi setting by changing the print quality to best in the front panel and driver software.
- 2 The problems may be inherent in the image you are trying to print. Try to improve the image with the **application** that generated the file.

Problems with printing lines

Description of problem

When you look at the image you have printed there are:

- Missing or faint lines
- Printed text having missing parts to them.

Shown below are examples of what you might see if you have problems with printing lines.

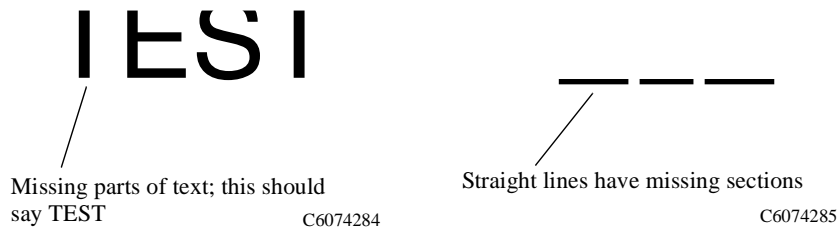

How to solve the problem

- 1 Go to the printer submenu and press **Enter**.

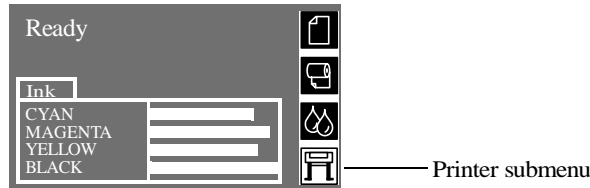

- 2 Go to Utilities/Recover Printheads.
- 3 Select the printhead color which has the problem. The printer will try to 'Recover' the defective printhead. If you are not sure which printhead color is giving you the problem, select all of the printheads. Please wait while printer tries to recover the printheads.
- 4 **Reprint** the image you were attempting to print before (in the same mode) to see if the problem still exists.
- 5 If the problem continue, reprint the image using **Best** mode.
- 6 If printing in Best mode is not acceptable, replace the offending printheads. If you're not sure which printhead is giving you the problem, print out the Print Quality Test. This will help you find the faulty printhead.

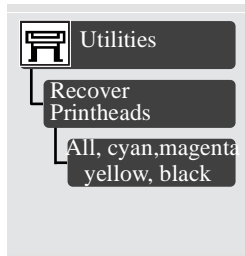

Problems with Color-to-Color Alignment

Description of problem

When you look at the image you have printed:

- The colored lines are printing double and they are the wrong colors,

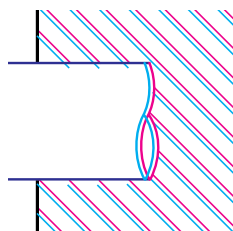

C6074286

- The borders of colored blocks are overlapped and the overlapping areas have different colors in them.



C6074287

- Vertical lines are mis-aligned or fuzzy (not smooth)

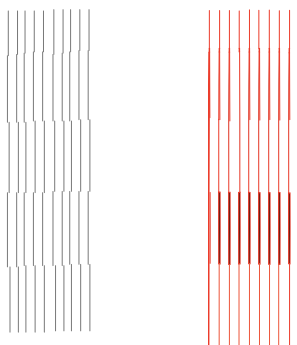

C6074304

How to solve the problem

- 1 Make sure you have paper loaded (not clear film, tracing paper or vellum).

- 2 Go to the Printer submenu and press **Enter**.

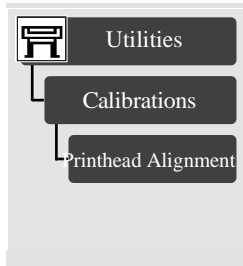
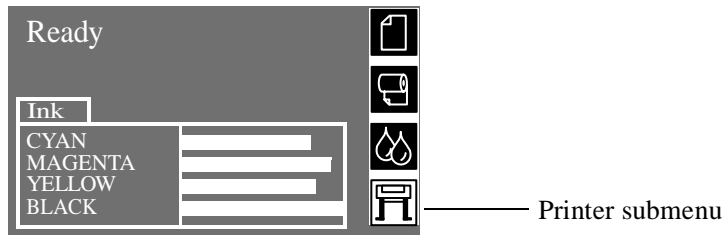

- 3 Perform the Printhead Alignment Calibration by going to Utilities/Calibration/Printhead Alignment. Please wait as the process of aligning the printheads takes a few minutes.
- 4 Reprint the image you were attempting to print before (in the same mode) to see if the problem still exists.

Problems with Horizontal Lines (Banding)

Description of problem

When you look at the image you have printed there are light or dark lines on the image, these are particularly highlighted in high density ink areas. This problem is known as banding.

IMPORTANT

Banding can occur to a certain degree in draft and normal mode when printing high density prints. To obtain the best image always print in Best Mode.

Shown below is an example of what you might see if you have problems with banding.

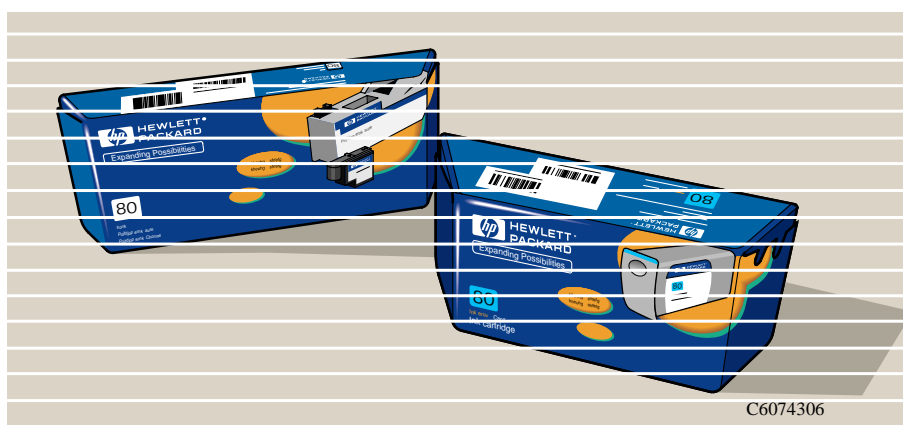

How to solve the problem

NOTE

While performing the next procedure, duplicate the condition the printer was in when you discovered the problem: use the same media and the same print mode.

- 1 Ensure that the paper you have selected in the front panel is the same paper that you have loaded.
- 2 Perform the Printhead Alignment Calibration.
- 3 Reprint your image.
- 4 If you have printed your image in Normal or Draft mode and it is not acceptable to you, re-print it in Best mode. Check the front panel and driver selection to make sure that Best mode is selected.

- 5 Go to the printer submenu and press **Enter**.

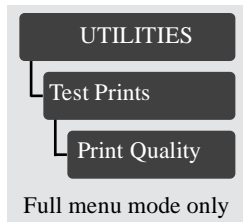
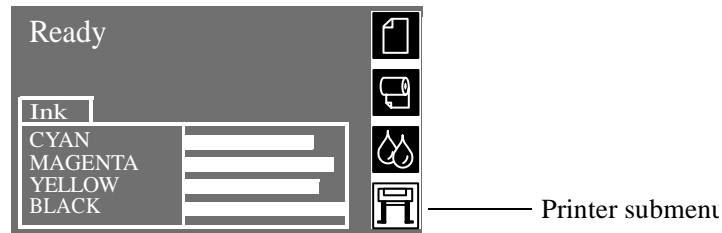

- 6 Go to Utilities/Test Prints/Print Quality and press **Enter**.
- 7 The printer will print a diagnostic test print. This will help you find the source of the banding problem. Please wait as the process of printing the Print Quality Test print takes a few minutes.
- 8 Look in the **top** section of your Print Quality Test. Check to see if there are any of the following examples of defects in the print.

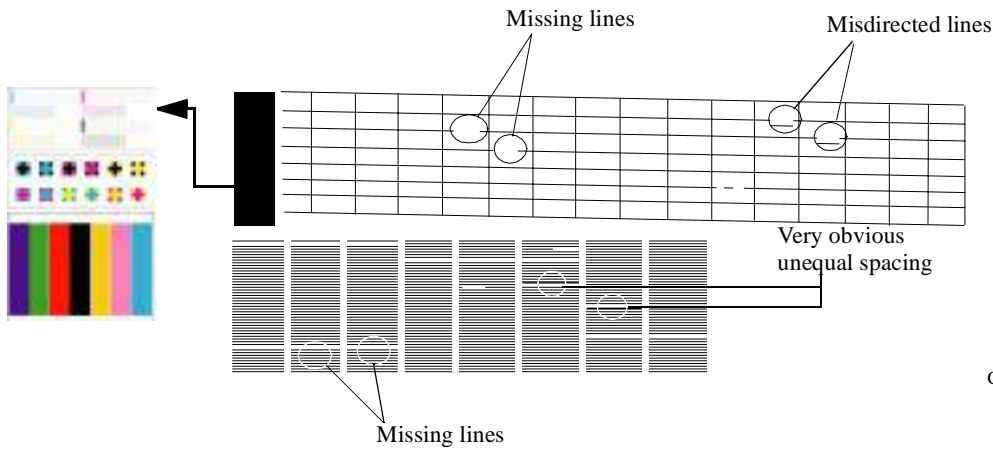

C607482

- 9 If there are any of the above defects visible in the test print, continue with step 9a. If there are no defects in the top part of the print test, go to directly to step 10.

- a Go to the printer submenu and press **Enter**.

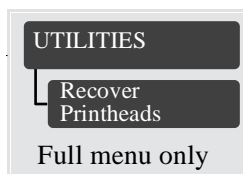

- b Go to the Utilities/Recover Printheads and press **Enter**
- c Select the printhead color that displayed the defects in the Print Quality Test. If you are not sure which printhead color is giving you the problem select all of the printheads.

- d Perform the printhead alignment procedure.
 - e Reprint the image you were attempting to print before (in the same mode) to see if the problem still exists.
 - f If there is no improvement in the quality of your image, print the Print Quality Test again and continue to the next step.
- 10** Check the **bottom** section of the Print Quality Test. If there is banding in **all** colors, continue with step 10a. If there is banding in only a few colors go directly to step 11.

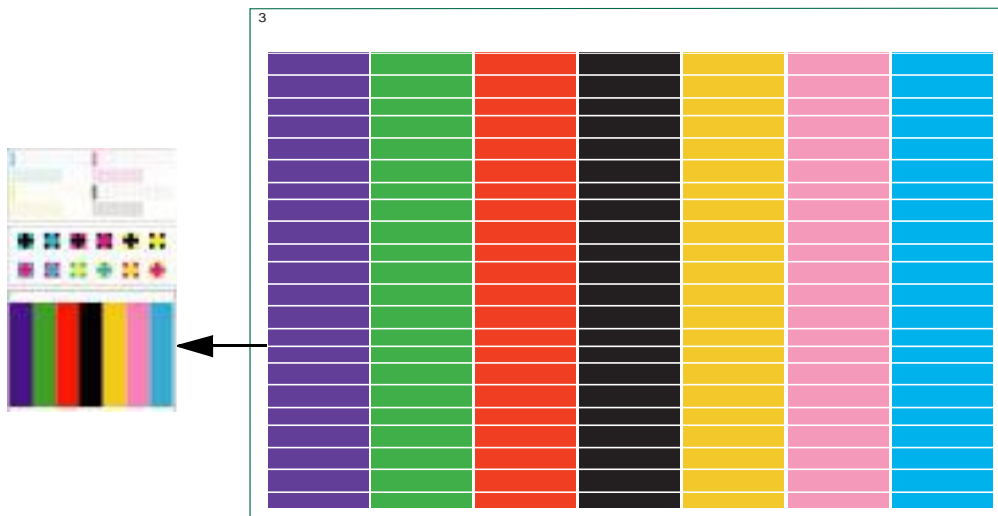

C6074281

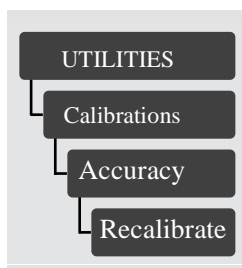

- a It is possible that the banding was caused because the customer was using non-HP media. If the customer still wants to use non-HP media, recalibrate the paper accuracy by performing the accuracy calibration. Performing this will overwrite the default setting for **only** the paper that you have selected.

NOTE: If the customer wants to use HP certified paper at a later stage, they can restore the optimal setting to what it was by going to Utilities/Calibration/Accuracy/Restore Factory.

- 11** When you look at the image you have printed there is banding on the image, but only in a **few** colors, similar to the example shown below.

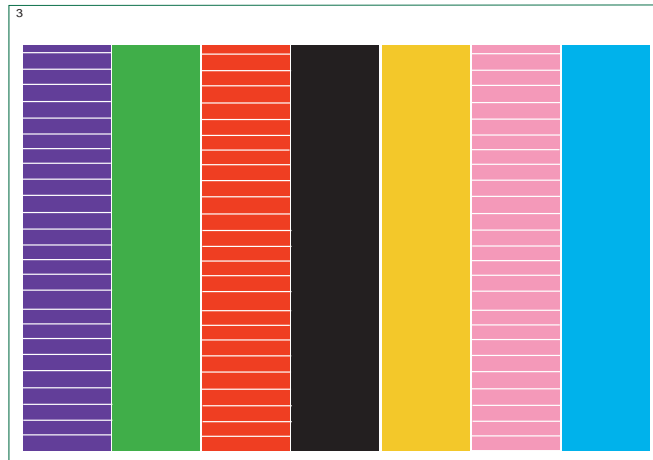

- a** The possible combinations with this problem are:
- Banding in **cyan, blue** and **green** columns only, but more evident in cyan. This means that the cyan printhead could be permanently damaged.
 - Banding in **magenta, red** and **blue** columns only, but more evident in magenta. This means that the magenta printhead could be permanently damaged.
 - Banding in **yellow, red** and **green** columns only, but more evident in yellow. This means that the yellow printhead could be permanently damaged.
 - Banding in **black** column only. This means that the black printhead could be permanently damaged.
- b** If you want optimal print quality from your printer, replace the damaged printhead with a new one.

NOTE

However, the printer can still produce good quality line prints.

No Printing Defects Found in the Print Quality Test

If all the test patterns from the Print Quality Test are correct and you still experience print quality problems, here are some of the more likely causes to check:

- The print mode used in your printer is not right for the image you are printing (this is defined by the printer's front-panel menu selections)
- Non-HP driver
- The RIP (If you are using one)
- The software applications you are using.

Use the following table to configure your system correctly.

What to Configure	Configuration Setting	Optimal Setting
Printer Front-Panel Menu	Media	Unload the current media and load it again after changing the media type in the front panel.
	Dry time	Set to Automatic.
HP driver (Windows, AutoCAD or Mac) (HP DesignJet 2500CP)	Print mode setting	Set to Best.
Non-HP drivers (Software RIPs)	The settings available depend on the driver. The most typical settings are: <ul style="list-style-type: none"> ■ Print Quality Settings ■ Half Tone ■ Media selection See the user's guide for your application for more information about its print quality settings.	In the software application: <ul style="list-style-type: none"> ■ Set Print Quality to Best ■ Use no Half Tone (or printer default.) ■ Make sure that the media setting matches the media loaded in the printer.

Solving Color Accuracy problems

These are two areas you should review when troubleshooting a color accuracy problem:

Configuration (PostScript option only)

Check that you are using the correct driver setting and CRD information for the software. Check which ink emulation mode has been selected in the front panel.

Media

Make sure that the media loaded is genuine HP media and that the correct media type has been selected on the front panel and in the driver.

Color Consistency problems

- If color consistency is important for the customer, it is recommended that they do not use HP-GL/2 to print with.
- Some media may discolor or change with age. Check that the media is fresh and has been stored correctly.
- If the environmental conditions that the customer is printing in change rapidly, you may see changes in the color consistency. By reducing the time the print stays in extreme environmental conditions after being printed (especially very high humidity) you can reduce the color consistency problems.
- If you notice that there are color changes between different printers i.e. between the 750C and this printer. It is normal. There will be color differences between HP DesignJet printers because the other printers use a different type of ink.

Long Term Color Bleeding (Glossy Papers)

If you see the colors are bleeding into the paper i.e. the color is soaking into the paper making the lines fuzzy and bleary. This will be because of the humidity conditions that the printer is working under:

- Ask the customer to change the paper that they are printing with.
or
- Remove the printer from the high humidity conditions.

Color Accuracy Configuration

The configurations of the printer, the driver, and the software RIPS define how ink is applied to each type of media. Use the information in the following table to configure the printer and software for best color accuracy.

Location of Setting	Setting Description	Selection
Printer Front-Panel Menu	Media	■ Set to match the media type loaded in the printer.
	Ink Emulation (PS only)	■ Set the type of CMYK inks that your software generates. If you use HP drivers use “Native”.
	Ink Limiting (PS only)	■ Set to ON.
	Color Calibration (PS only)	■ Set to ON.
HP Drivers	Media	■ Set to match the media type loaded in the printer.
Non-HP drivers (Software RIPS)	Media or equivalent setting	■ Set to match the media type loaded in the printer. See the documentation that came with your software for information.
	Color correction option or equivalent	■ Do the color correction calibration if one is available.

Media

Always make sure that the customer is using the appropriate media for the required image and that it is consistent with the software application being used. To ensure color accuracy and print-quality performance of the printer, only media types that have been certified for the printer should be used. Use of non-HP media or HP media not certified for the printer may significantly reduce the color and print quality of the required images. For details of HP media, refer to the **User's Guide** or the **Media Guide for the HP Designjet Printers**.

NOTE

To have accurate colors, the media settings must match the type of media loaded in the printer.

If the customer is using non-HP media with HP drivers, the colors in the required print may not be accurate. Advise the customer to use HP media if they want to improve the accuracy of the colors.

There are Smears or Scratching on the Printed Media

This problem can appear on paper-based coated media if a lot of ink printed quickly. The media cannot absorb the ink quickly enough and becomes distorted. As the printheads move over the media, the printheads and the media come into contact with each other and the printed image is smeared.

- 1 Press the **Cancel** key on the front panel; if you continue to print, the paper may damage the printheads.
- 2 Cancel the print job from your computer application.

In order to obtain better results perform the following:

- Use HP recommended media. If the image you are printing has intense color, use HP Heavy Coated Paper
- Use extended margins, or try to increase the print margins by relocating the image on the page from the software application.
- If the customer is using 'Media Saving Options' from the advanced section of the HP- GL/2 Driver, try disabling one or both of the options 'auto rotate' and 'inked area'.

If the above fails to solve the problem of smears and scratching, change the media that the customer is using to a non-paper based media such as HP High Gloss Photo Paper.

Parts and Diagrams

7

Printer Support	7-2
Rear Covers	7-4
Electronics Module	7-6
Right Hand Cover	7-8
Left Hand Cover and Window	7-10
Right Hand Assemblies	7-12
ISS and APS Assembly	7-14
Clutch Assembly	7-16
Carriage Assembly	7-18
Scan-Axis Assemblies	7-20
Drive Roller and ARSS Miscellaneous Parts	7-22
Paper Path Assemblies	7-24
Pinch Assembly	7-26
Drive Roller Assemblies	7-28
Center Guide and Media Sensor	7-30
Tubes Guide Assemblies	7-32
Ordering Accessories	7-34

Printer Support

Printer Support			
Reference on Drawing	HP Part Number	Quantity	Description/Comments
1	C6072-60183	1	Tray Assembly
2	C6071-60182	2	Foot Assembly
3	C6072-60184	2	Legs Assembly
4	C6071-60181	1	Bin Assembly
5	C6072-60185	1	X-Brace Assembly
-	C6071-60180	1	Hardware Kit (Includes Screw Drivers)
-	C6072-60017	1	Bin Cover Assembly

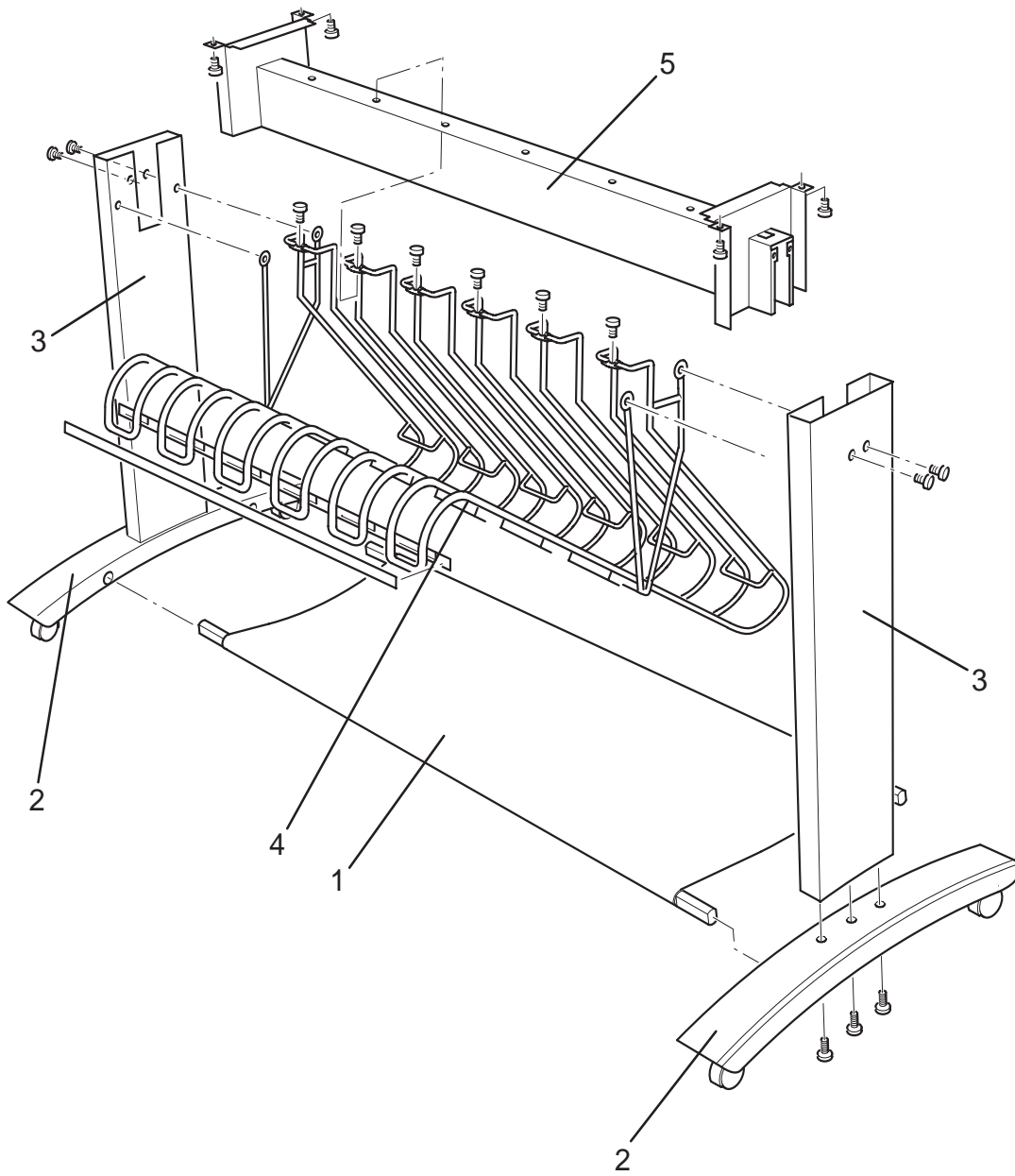

Figure 3: Printer Support

Rear Covers

Printer Support			
Reference on Drawing	HP Part Number	Quantity	Description/Comments
1	C6072-60168	1	Top Cover
2	0515-0382	5	Screw
3	0515-4228	1	Screw
4	C6072-60169	1	Back Cover (Includes Blank Serial Number Label)
5	C2847-20017	3	Screw
6	2190-0760	3	Washer
7	C6072-60186	1	Rear Platen
8	0624-0771	2	Screw
9	C6071-60148	3	Tail Deflectors
10	C6072-60170	1	Back EMC Cover
11	0535-0043	5	Nut
12	0515-2278	2	Screw
13	C6072-60188	1	Mount Bracket (Includes Left and Right Mount Bracket)
14	0624-0771	4	Screw

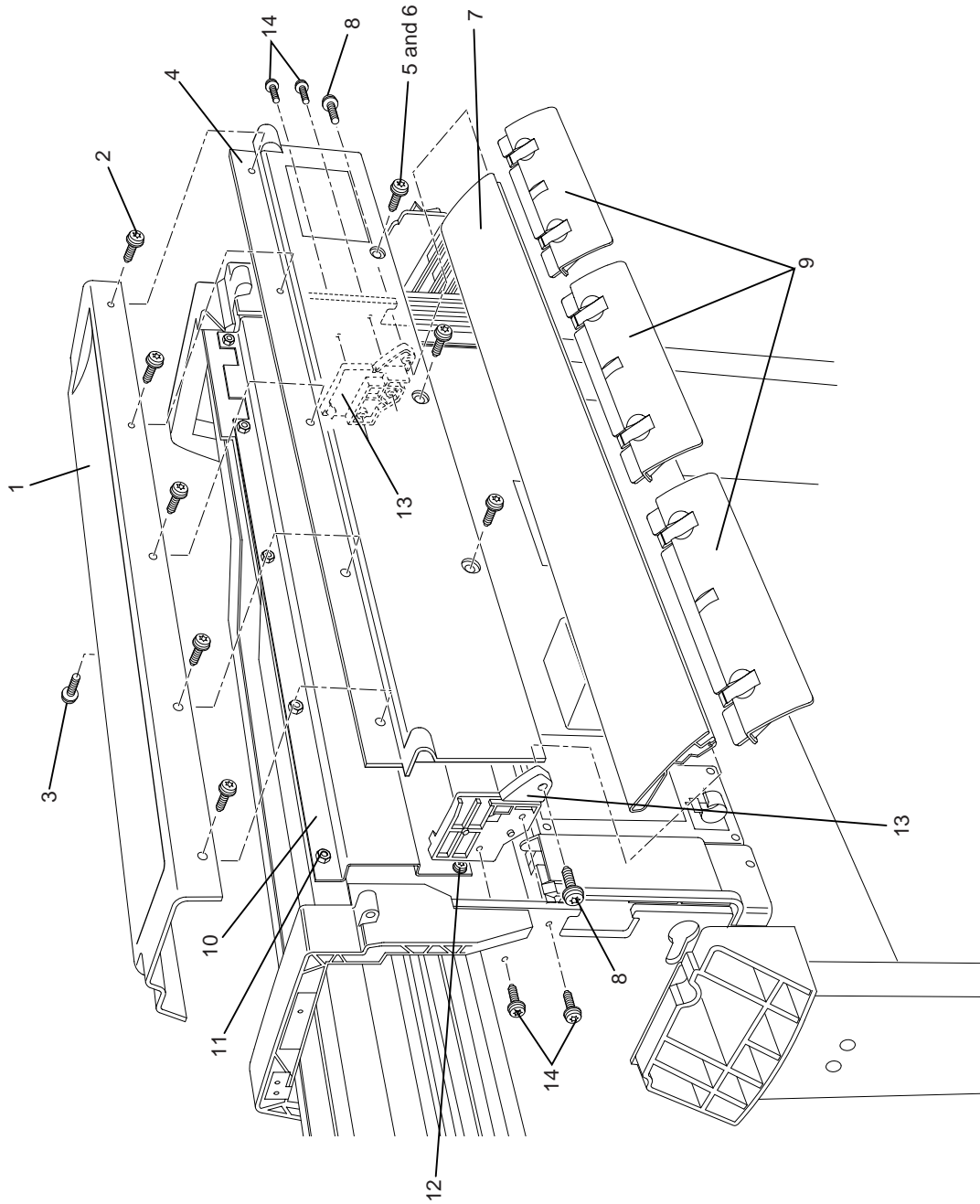

Figure 4: Rear Covers

Electronics Module

Printer Support			
Reference on Drawing	HP Part Number	Quantity	Description/Comments
1	J3113-61001	1	EIO Card
2	C6075-60005	1	Hard Disk Drive
3	C6072-60176	1	DIMM Cover
4	0515-2246	4	Screw
5	C6074-60003	1	DRAM DIMM 16MB
	C6074-60004	1	DRAM DIMM 32MB
	C6074-60005	1	DRAM DIMM 64MB
6	C6074-60009	1	Firmware DIMM (HP DesignJet 1050C)
	C6075-60009	1	Firmware DIMM (HP DesignJet 1055CM)
7	C6072-60171	1	Left Rear Cover (Includes Ferrite and Clip)
8	0515-2282	1	Screw
9	C6072-60172	1	Right Rear Cover
10	0515-2282	1	Screw
11	C6072-60146	1	Electronics Module
12	0515-0382	4	Screw (for Electronics Module)
-	C6072-60177	1	EIO Card Cover

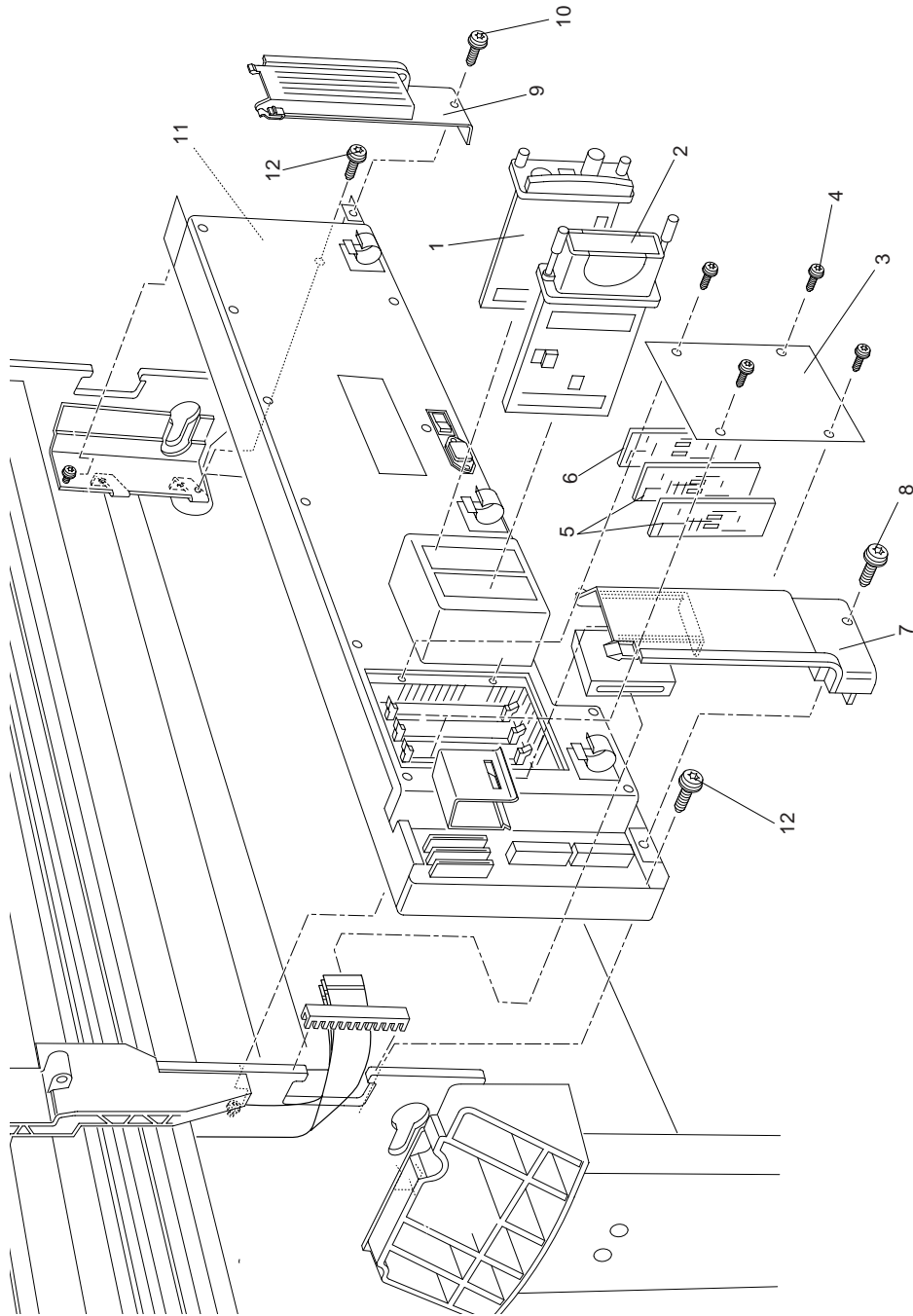

Figure 5: Electronics Module

Right Hand Cover

Printer Support			
Reference on Drawing	HP Part Number	Quantity	Description/Comments
1	C6072-60165	1	Right Hand Cover (Includes Front Panel Cable)
2	0624-0771	4	Screw
3	C6072-60174	1	Right Hand Trim (Includes Window Sensor)
4	0515-2248	1	Screw
5	0624-0771	1	Screw
6	C6072-60175	1	Front Panel Assembly (Includes Front Panel Cable)
-	C6071-60154	1	Quick Reference Guide Holder

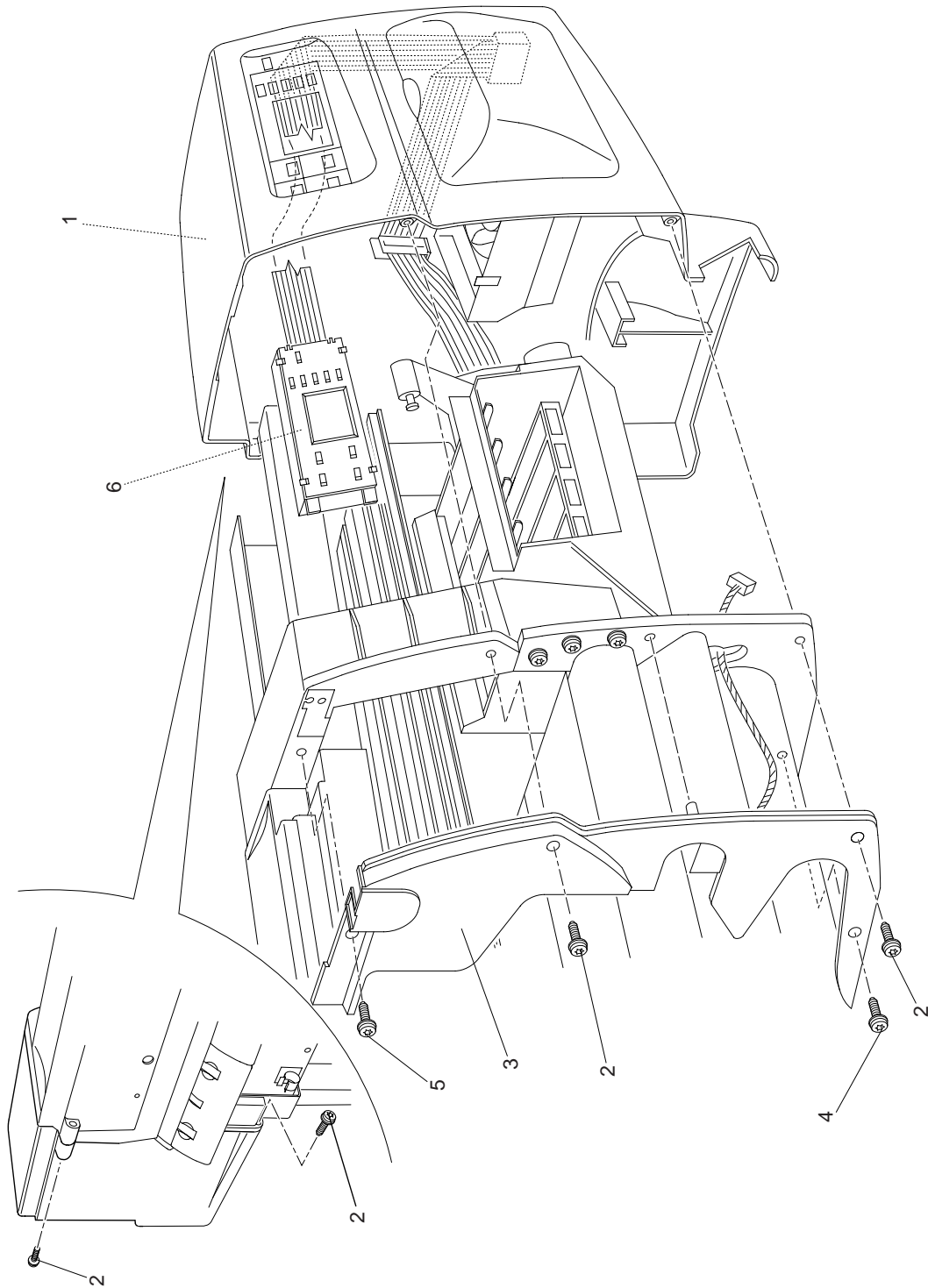

Figure 6: Right Hand Cover

Left Hand Cover and Window

Printer Support			
Reference on Drawing	HP Part Number	Quantity	Description/Comments
1	C6072-60167	1	Left Hand Cover
2	0624-0771	4	Screw
3	C6072-60173	1	Left Hand Trim
4	0515-2248	1	Screw
5	0624-0771	1	Screw
6	C6072-60164	1	Window
-	0624-0704	2	Screw (for rear door to access the Ink Tubes System)
7	C6072-60145	1	Ink Tubes System (Includes Setup Printheads, Ink Collector, Carrier Clip, Nye Oil and ISS Housing Foam)
8	C6072-00002	1	Nameplate (HP DesignJet 1050C)
	C6075-00001	1	Nameplate (HP DesignJet 1055CM)
9	C4704-00119	1	Adobe Logo Label (Only for HP DesignJet 1055CM)
-	C6071-60167	1	Setup Printheads

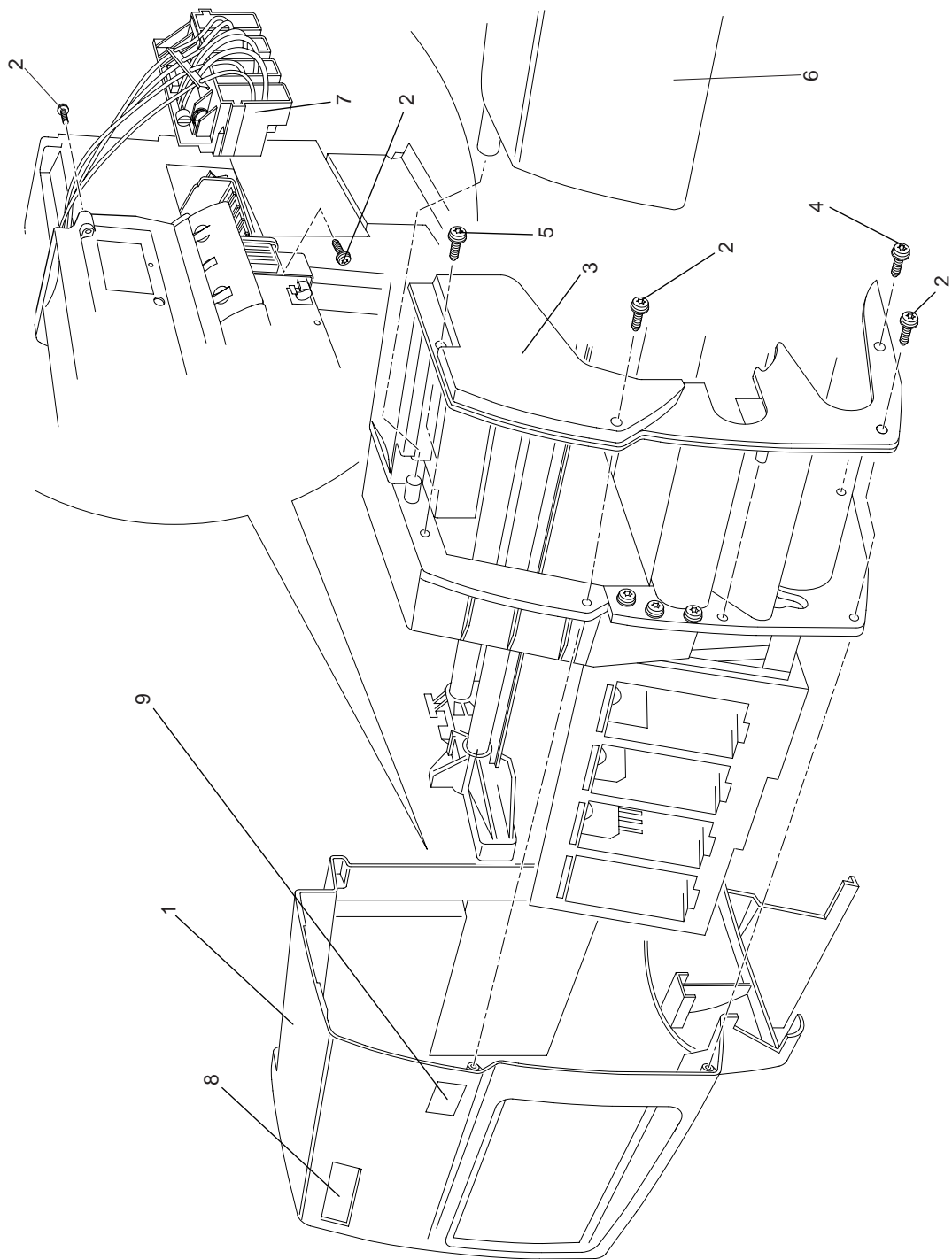

Figure 7: Left Hand Cover and Window

Right Hand Assemblies

Printer Support			
Reference on Drawing	HP Part Number	Quantity	Description/Comments
1	C6072-60178	1	Service Station Assembly (Includes Drop Detector and Primer Assembly)
2	0624-0771	2	Screw
3	0515-2248	1	Screw (for Service Station)
4	C6072-60159	1	Vacuum Fan
5	0515-2248	4	Screw
6	0515-1349	2	Screw
7	C6072-60160	1	Paper-Axis Motor Assembly (includes Helical Gear and Grease)
8	0515-2248	4	Screw
9	C6072-60179	1	Drop Detector Assembly (Includes Spittoon Foam)

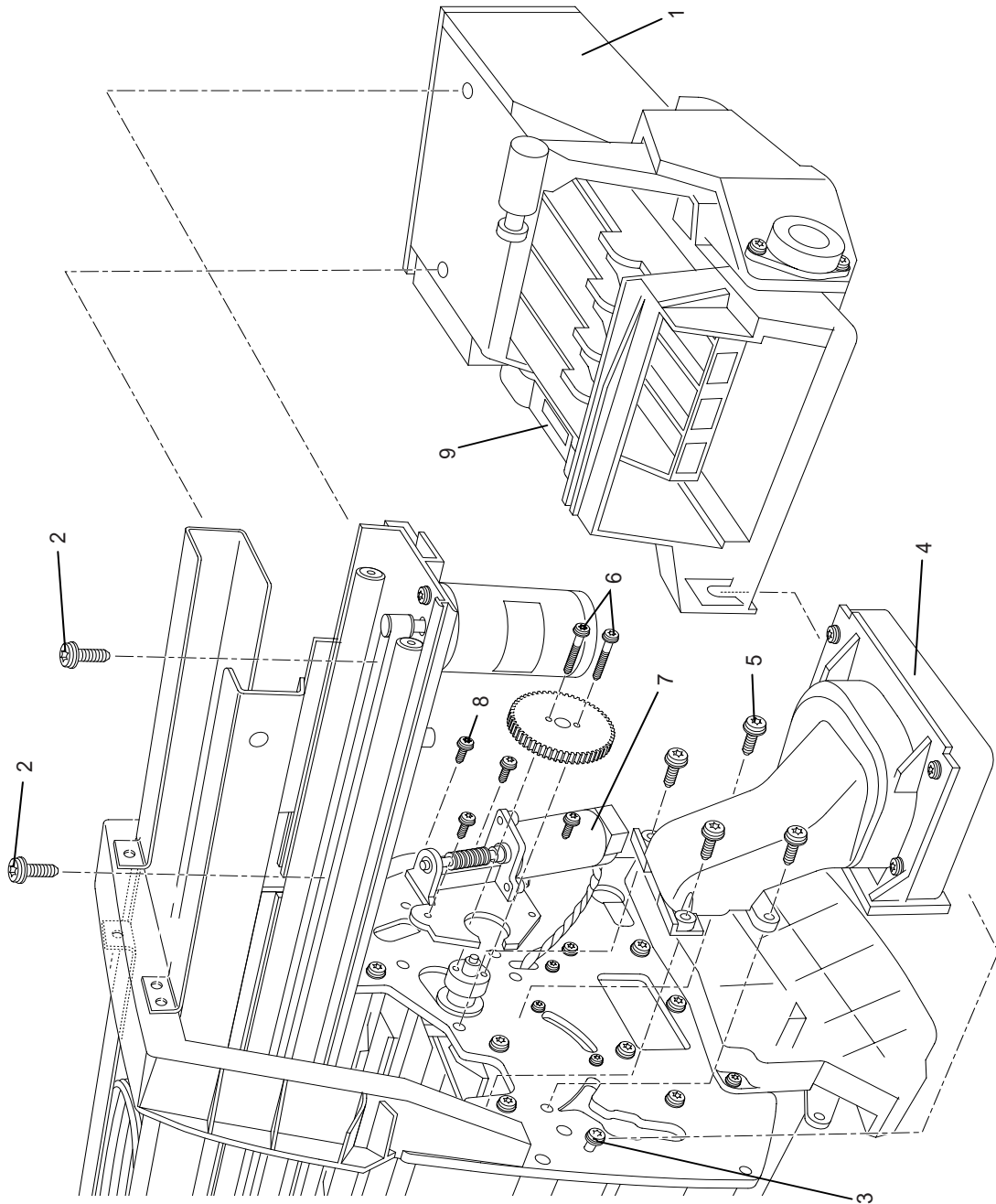

Figure 8: Right Hand Assembly

ISS and APS Assembly

Printer Support			
Reference on Drawing	HP Part Number	Quantity	Description/Comments
1	C6072-60015	1	Ink Supply Station (ISS)
2	C6072-60016	1	Air Pressurization System (APS)
-	C6071-60168	1	Ink Leak Detector (Includes Ink Collector, Leak Sense Cable and Leak Sense Cable Cip)

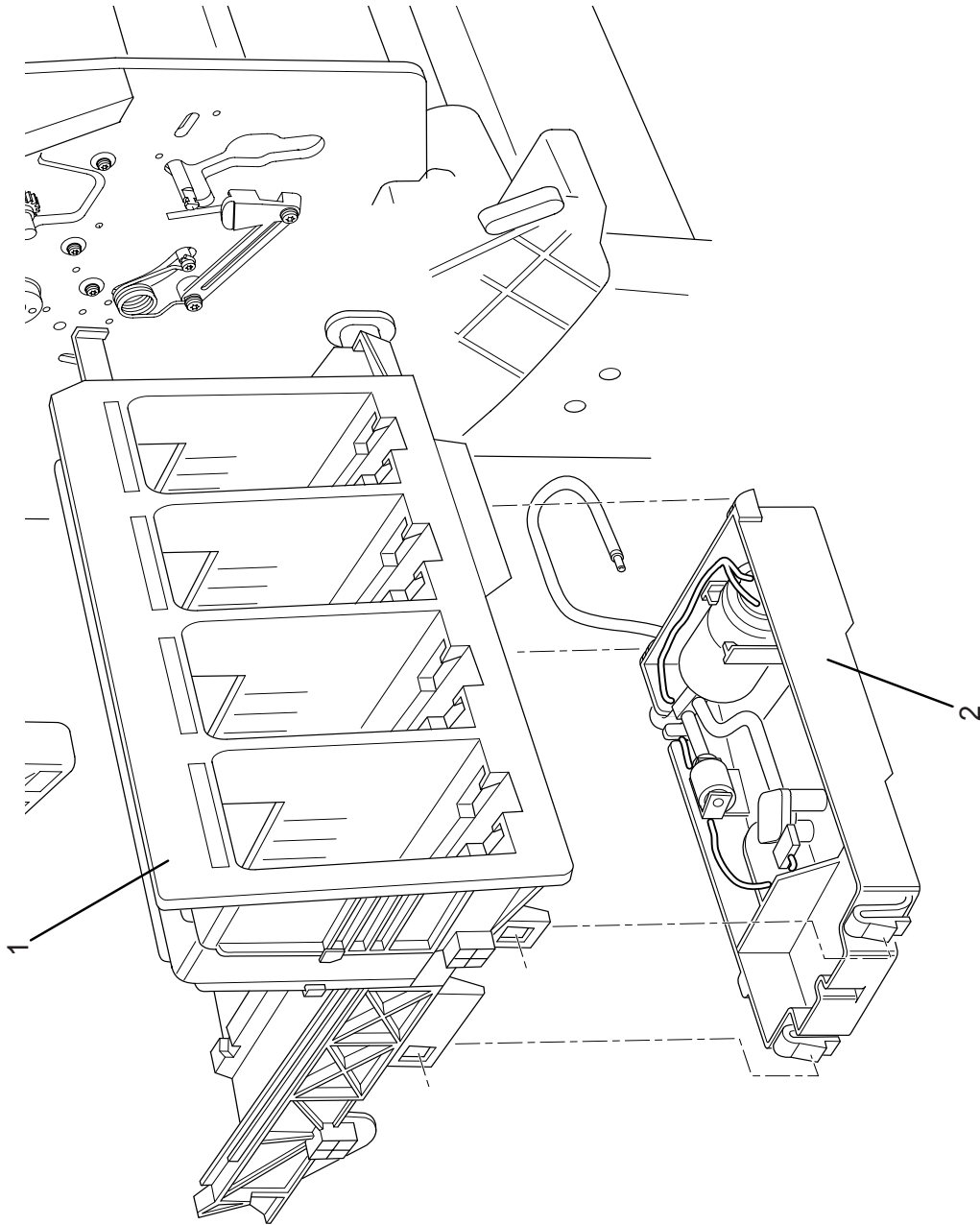

Figure 9: Ink Supply Station

Clutch Assembly

Printer Support			
Reference on Drawing	HP Part Number	Quantity	Description/Comments
1	C6072-60151	1	Clutch Assembly
2	0515-2278	2	Screw

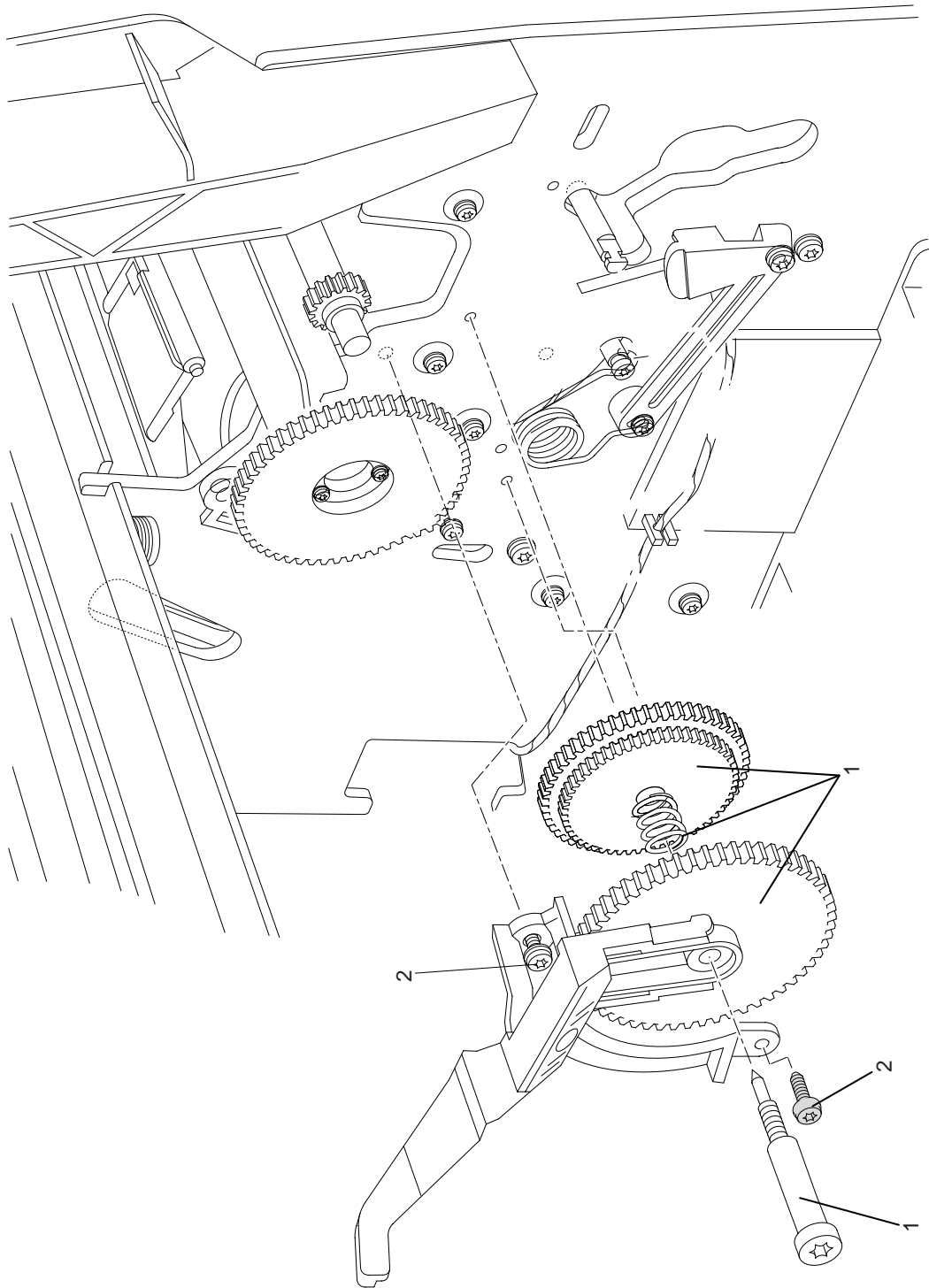

Figure 10: Clutch Assembly

Carriage Assembly

Printer Support			
Reference on Drawing	HP Part Number	Quantity	Description/Comments
1	C6072-60147	1	Carriage Assembly (Includes Carriage Height Tool, Cutter Assembly and Line Sensor)
2	C6072-60200	1	Cutter Assembly (Includes Screw and Washer)
3	0624-0737	1	Screw
4	3050-1982	1	Washer
5	C6072-60196	1	Trailing Cable (Includes Nye Oil, Trailing Cable Clip, Cover Cap, Trailing Ferrite and Ferrite Pincer)
-	C6071-60166	1	Carriage Height Tool (Also Included with the Carriage Assembly)

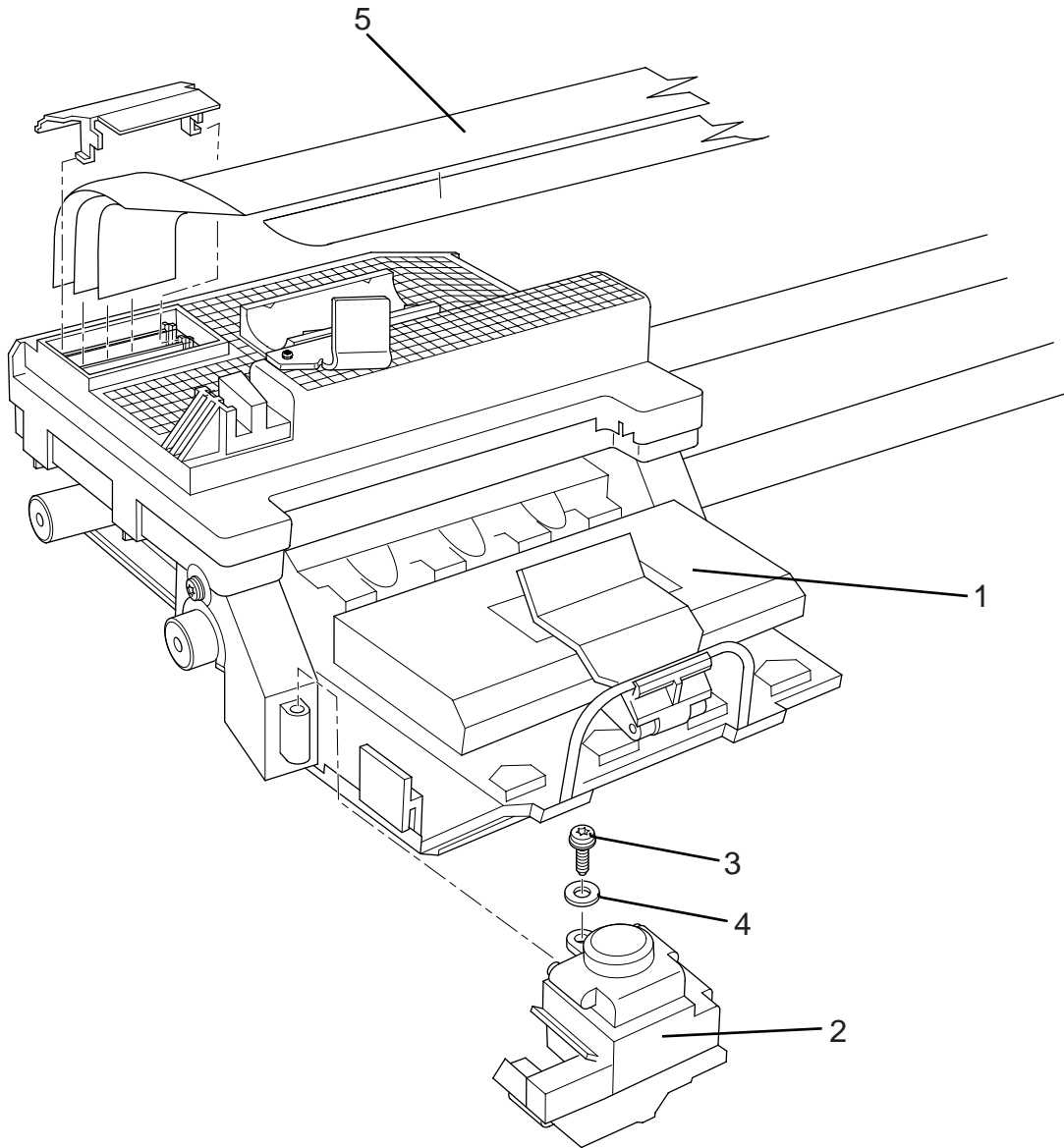

Figure 11: Carriage Assembly

Scan-Axis Assemblies

Printer Support			
Reference on Drawing	HP Part Number	Quantity	Description/Comments
1	C6072-60148	1	Scan-Axis Motor
2	0515-0382	2	Screw
3	C6072-60149	1	Tensioner Assembly (Includes Pulley Assembly, Pulley Spring, Wedge and Actuator Arm)
4	0515-0382	2	Screw
5	C6072-60199	1	Cutter Actuator Arm ((also included with item 3)
6	C6072-60198	1	Belt (Includes Oil)
7	C6072-60197	1	Encoder Strip
8	0535-0031	2	Nut
9	3050-0026	2	Washer
10	C6072-60158	1	Left Rollfeed Module
11	C6072-60155	1	Right Rollfeed Module
12	C6072-60156	1	Right Rollfeed Brake
13	0624-0704	1	Screw (for item 12)
14		1	Washer (for item 12)
15	C6072-60157	1	Left Rollfeed Brake
16	0624-0704	1	Screw (for item 15)
17		1	Washer (for item 15)
18		2	Screw (for item 15)

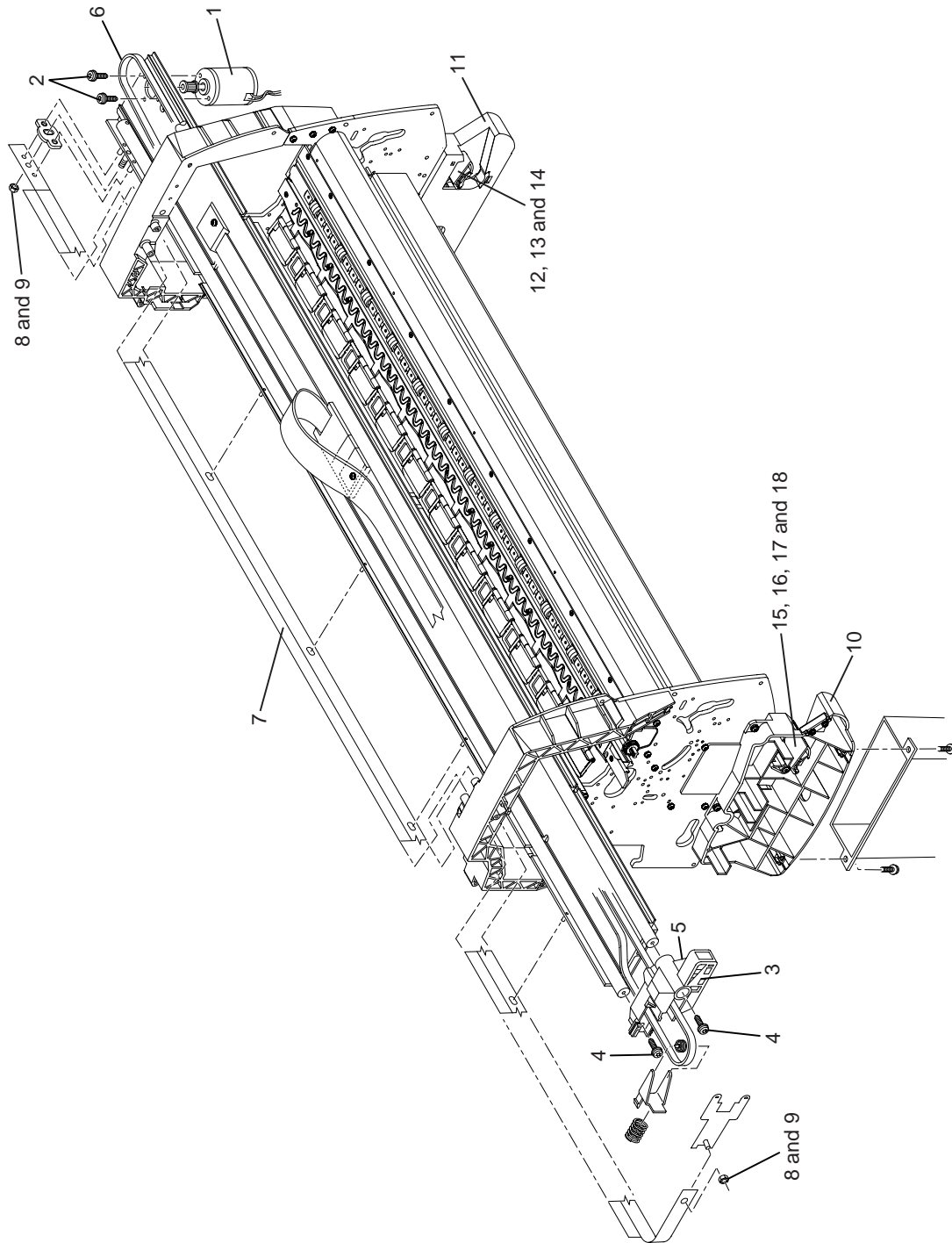

Figure 12: Scan-Axis Assemblies

Drive Roller and ARSS Miscellaneous Parts

Printer Support			
Reference on Drawing	HP Part Number	Quantity	Description/Comments
1	C6071-40017	1	Drive Roller Gear (See Note Below)
2	0515-2200	2	Screw
3	C6071-40016	1	Drive Roller Bracket (See Note Below)
4	0515-2282	2	Screw
5	C6071-60155	1	ARSS Miscellaneous Parts
6	0515-1743	1	Screw
7	C2847-20018	1	Screw

NOTE

Items 1 and 3 are not orderable separately. These parts are included when you order the Drive Roller Assembly on Page 7-28.

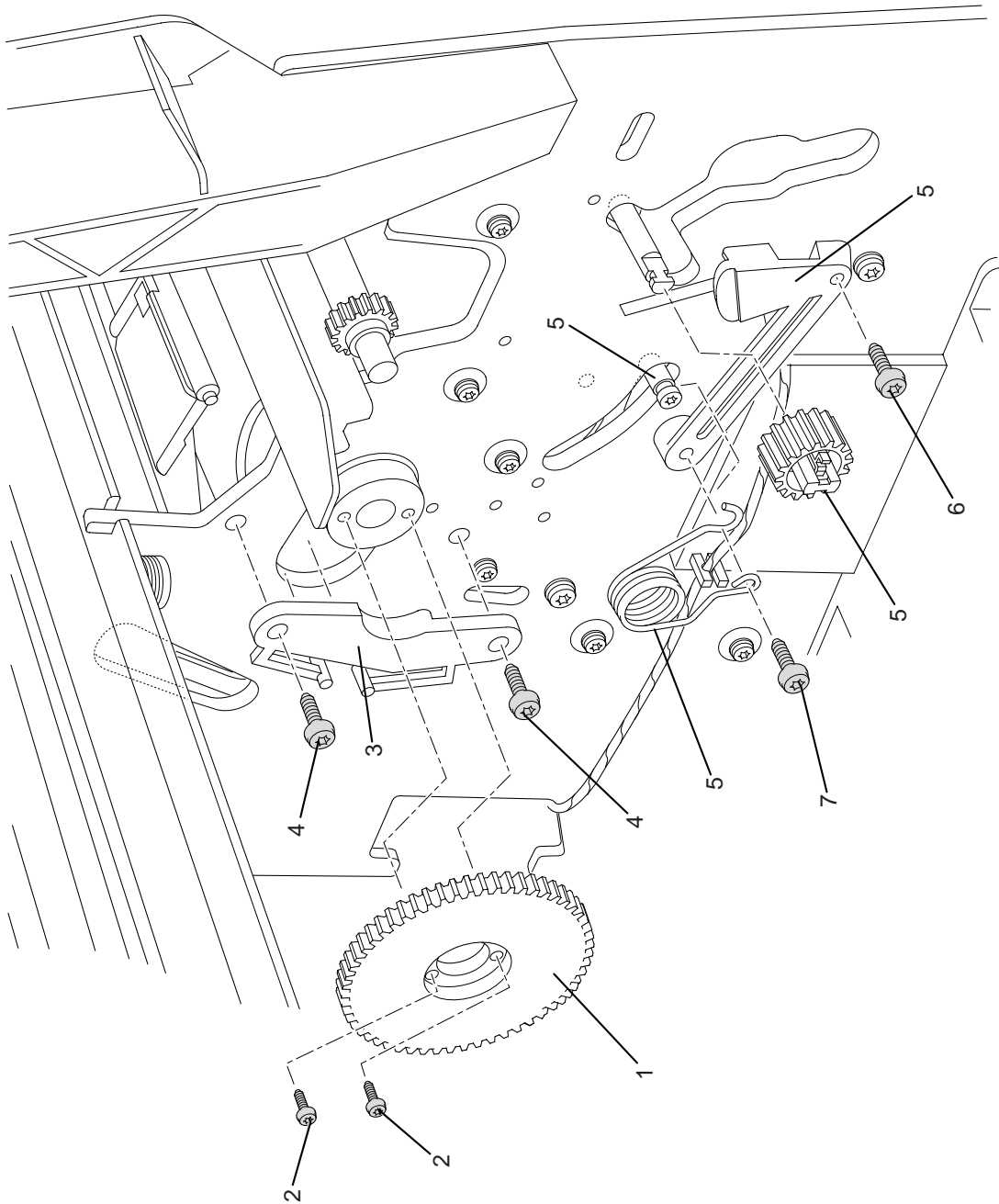

Figure 13: Drive Roller and ARSS Miscellaneous Parts

Paper Path Assemblies

Printer Support			
Reference on Drawing	HP Part Number	Quantity	Description/Comments
1	C6072-60153	1	Spindle
2	C6072-60154	1	Entry Roller
3	0515-2986	2	Screw
4	C6072-60150	1	ARSS Assembly
5	C6072-60152	1	ARSS Assembly Handles
6	0515-2250	8	Screw
7	C6072-60162	1	Front Platen Assembly (including screws)
8	C6072-60161	1	Centre Platen Assembly (including screws)

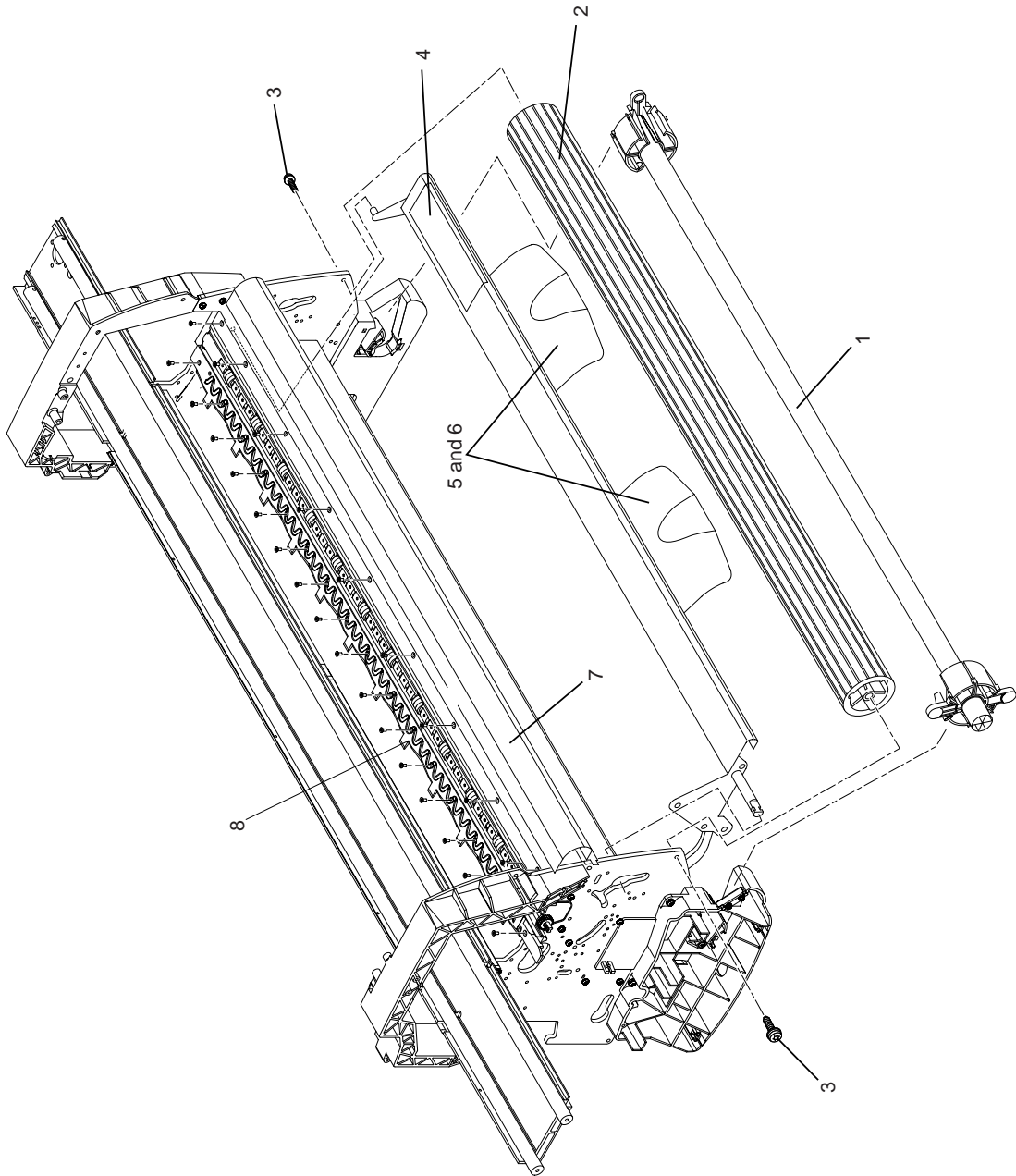

Figure 14: Paper Path Assemblies

Pinch Assembly

Printer Support			
Reference on Drawing	HP Part Number	Quantity	Description/Comments
1	C6072-60009	1	Pinch Assembly
2	0515-2981	1	Cam Lever Screw

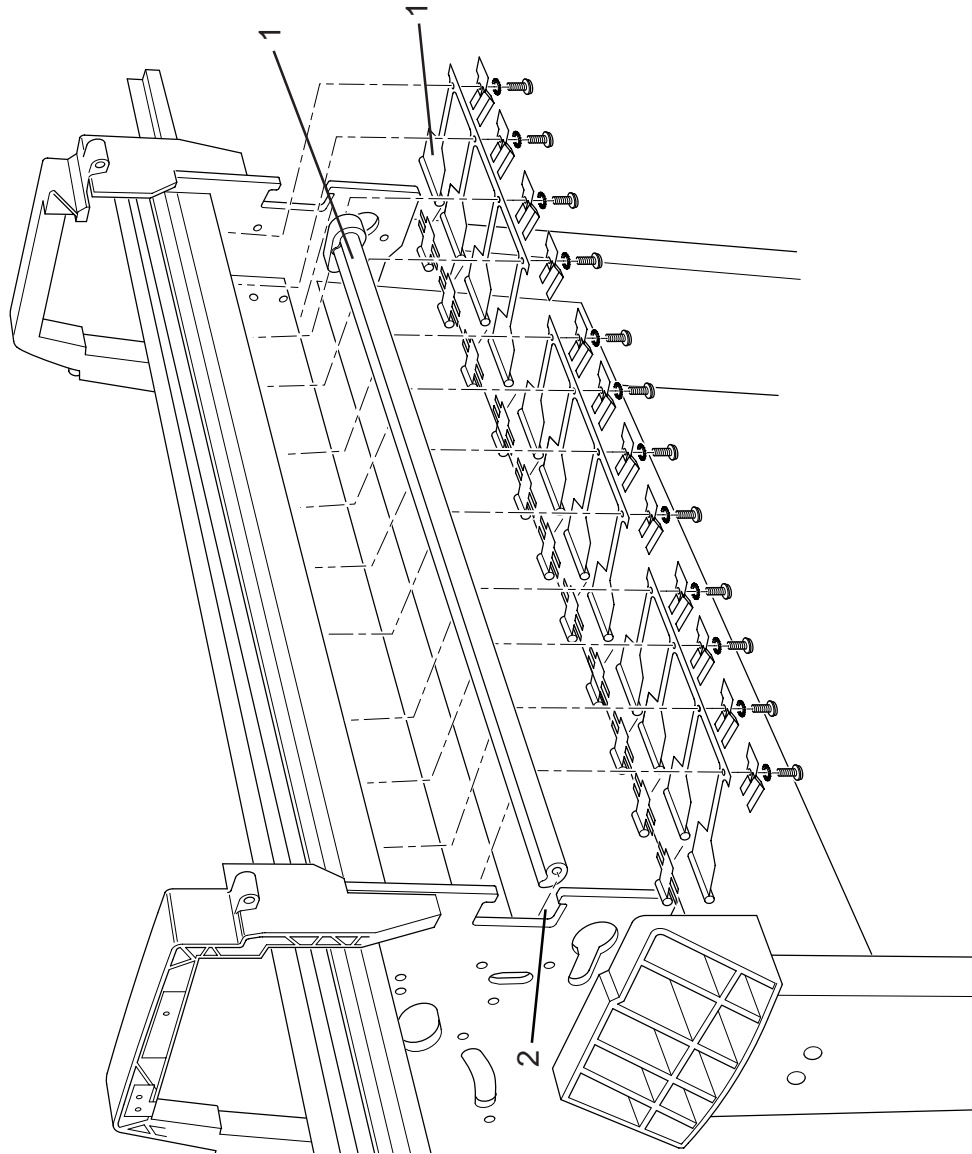

Figure 15: Pinch Assembly

Drive Roller Assemblies

Printer Support			
Reference on Drawing	HP Part Number	Quantity	Description/Comments
1	C6072-60191	1	Drive Roller Assembly
2	C6072-60163	1	Drive Roller Guide (Includes Item 4)
3	0515-2982	3	Screw (for Right Hand attachment of Drive Roller Guide)
	0515-2986	3	Screw (for Left Hand Attachment of Drive Roller Guide)
4	C6072-60011	1	Media Guide Strip
5	0624-0704	3	Screw

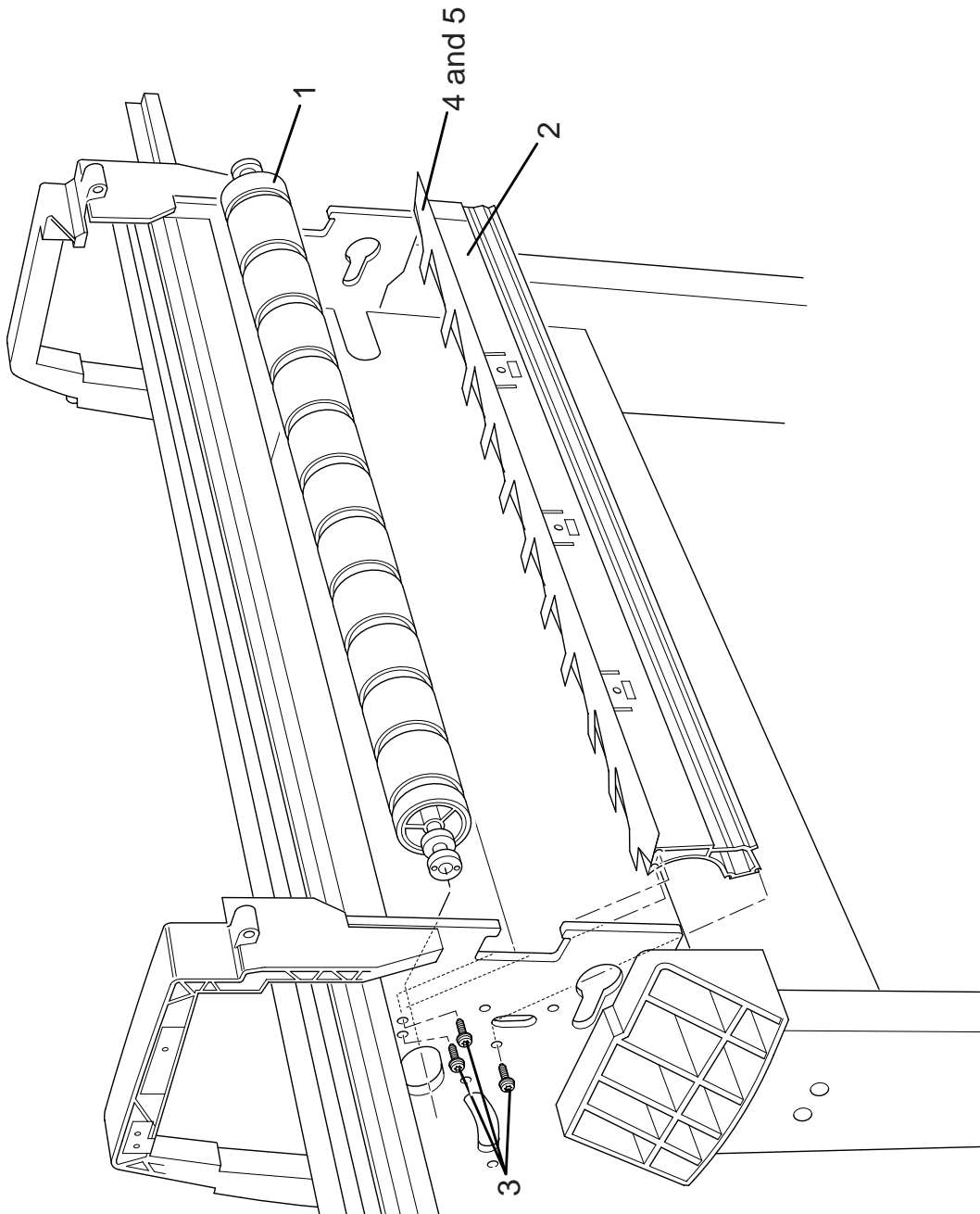

Figure 16: Drive Roller Assemblies

Center Guide and Media Sensor

Printer Support			
Reference on Drawing	HP Part Number	Quantity	Description/Comments
1	C6072-60189	1	Center Guide (Includes Item 3)
2	0515-2986	4	Screw
3	C6072-60190	1	Media Sensor

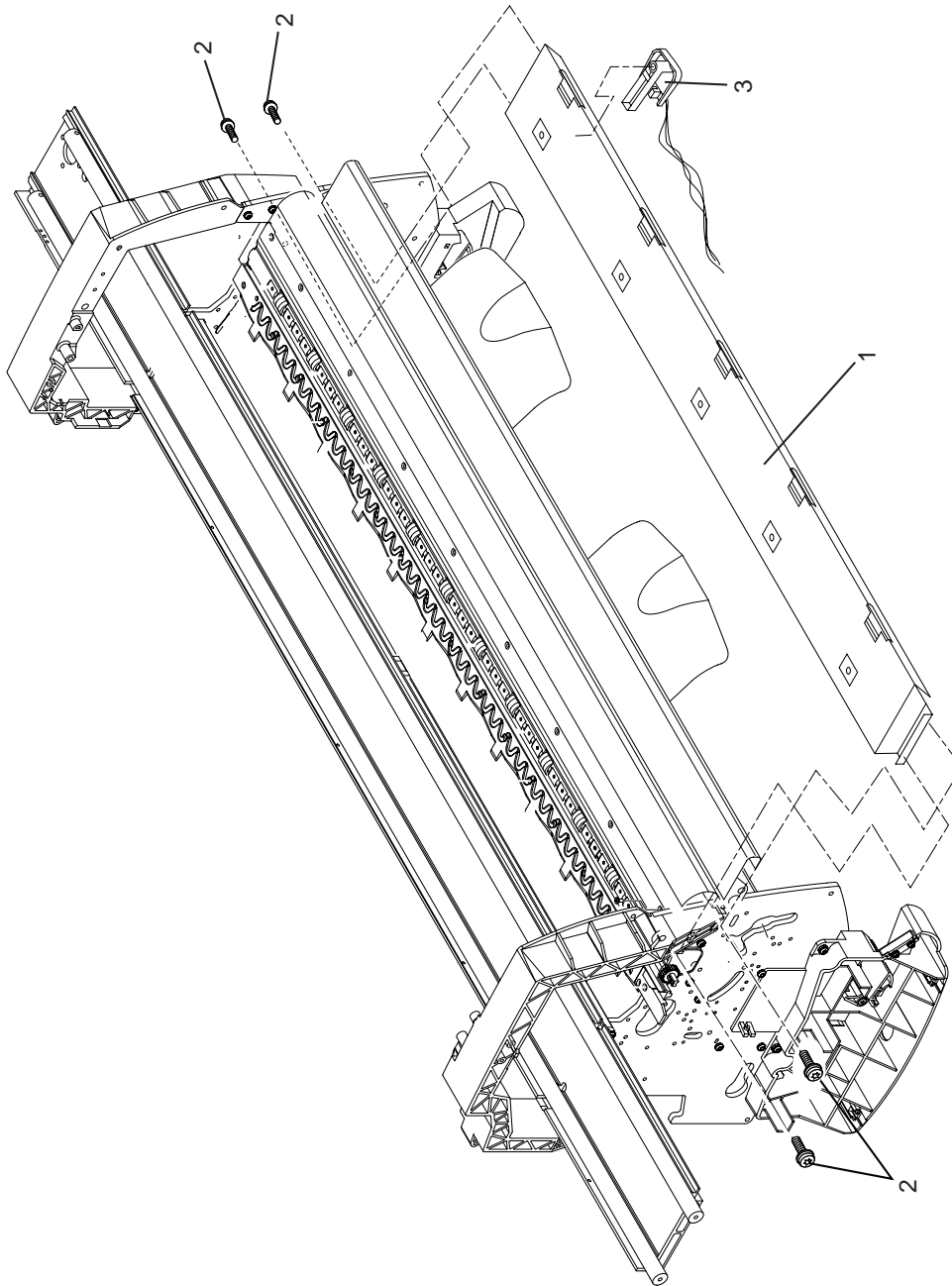

Figure 17: Center Guide and Media Sensor

Tubes Guide Assemblies

Printer Support			
Reference on Drawing	HP Part Number	Quantity	Description/Comments
1	C6072-60195	1	Tube Guide Assembly
2	C6072-60194	1	Front Guide Assembly
3	C6072-60193	1	Right Arc Assembly
4	0624-0771	8	Screw
5	C6072-60192	1	Left Arc Assembly

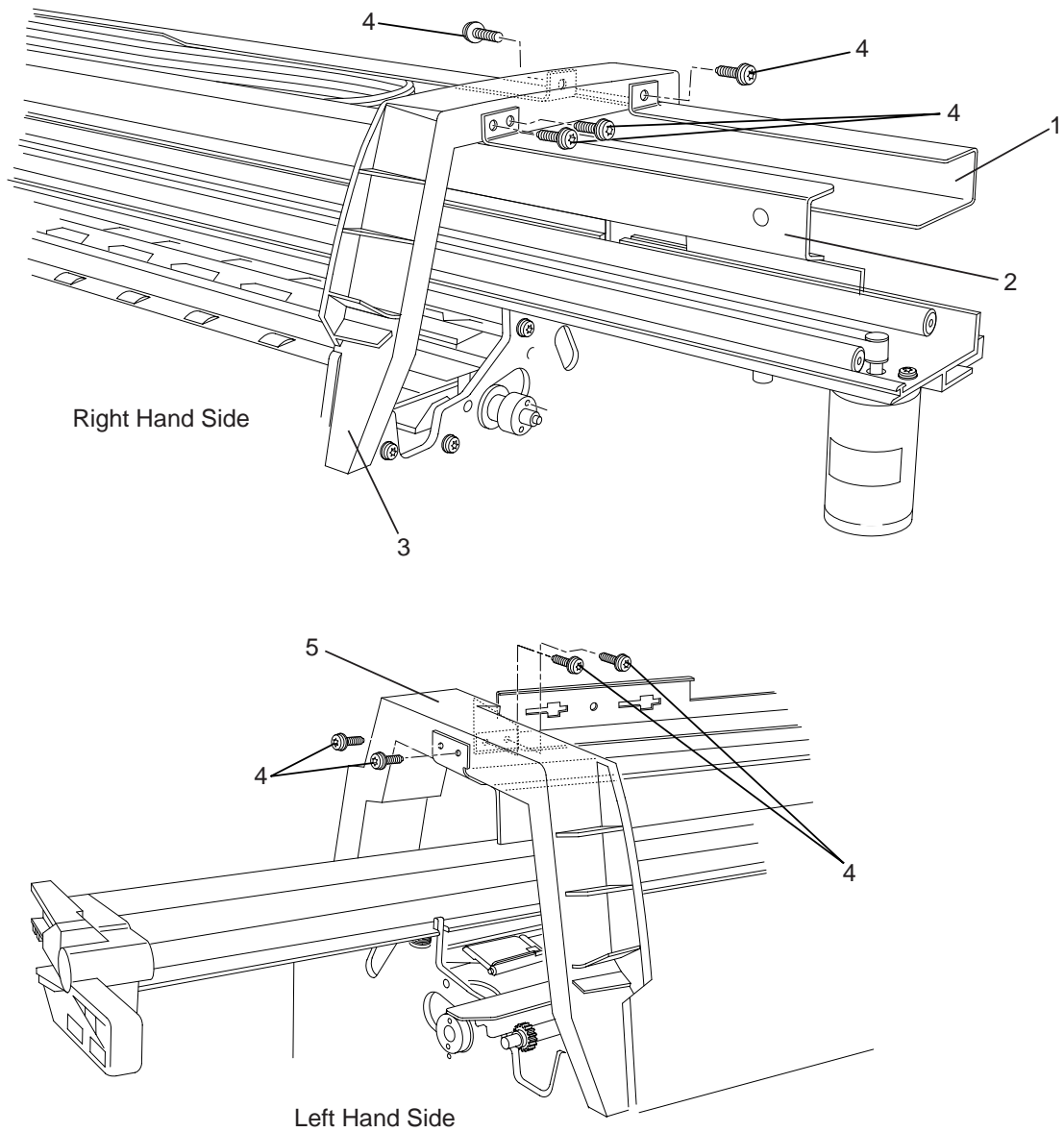

Figure 18: SRK Tubes Guide Assemblies

Ordering Accessories

Item		HP Part Number	
HP DesignJet 1050C and 1055CM Quick Reference Guide	English		C6071-90241
	Korean		C6071-90242
	Taiwanese		C6071-90243
	German		C6071-90244
	French		C6071-90245
	Spanish		C6071-90246
	Italian		C6071-90247
	Japanese		C6071-90248
	Portuguese		C6071-90249
	Chinese		C6071-90250
HP DesignJet 1050C and 1055CM User's Guide	English		C6071-90101
	Korean		C6071-90102
	Taiwanese		C6071-90103
	German		C6071-90104
	French		C6071-90105
	Spanish		C6071-90106
	Italian		C6071-90107
	Japanese		C6071-90108
	Portuguese		C6071-90109
	Chinese		C6071-90110
	Czech		C6071-90111
	Greek		C6071-90112
	Hungarian		C6071-90113
	Polish		C6071-90114
Russian		C6071-90115	
Thai		C6071-90116	
Turkish		C6071-90117	
Software Application Notes	English		C6074-90021
The HP-GL/2 and HP RTL Reference Guide	English		5961-3526
The Product Comparison Guide for HP-GL/2 and HP RTL Peripherals	English		5959-9734
PJL Technical Reference Manual	English		5021-0328
PostScript Upgrade Kit			C6076A
Hard Disk			C2985B
Memory Modules	All memory expansion modules are: 16, 32 or 64-MB DIMM 168pin x 64 EDO 50 nanoseconds, 3.3V	16 MB	C6251A
		32 MB	C6252A
		64 MB	C6258A
JetDirect EIO Network Cards	10Base-T		J3110A
	10 Base2, 10-T, LocalTalk		J3111A
	Token Ring		J3112A
	10/100Base-TX		J3113A

Item	HP Part Number		
<p>Drivers</p> <p>Latest versions of the following were shipped with the 1055CM: HP DesignJet PostScript Driver for Power Macintosh and Macintosh HP DesignJet PostScript Driver for Microsoft Windows HP-GL/2 Windows Driver HP DesignJet HP-GL/2 and HP RTL AutoCAD driver.</p> <p>NOTE: For details of the latest version available, please visit the Hewlett Packard web site at: http://www.hp.com/go/designjet or consult your HP dealer or sales representative.</p>			
<p>Paper Supplies</p> <p>This item is updated regularly. Please visit the Hewlett Packard web site at: http://www.hp.com/go/designjet or consult your HP dealer or sales representative.</p>			
	Color	175ml	350ml
Ink Cartridges	Black Cyan Yellow Magenta	N/A C4872A C4873A C4874A	C4871A C4846A C4848A C4847A
Value Pack (Printhead, Printhead Cleaner, 350ml Ink Cartridge)	Black Cyan Yellow Magenta	N/A N/A N/A N/A	C4890A C4891A C4893A C4892A
Item	Color		
Printheads and Printhead Cleaners		Black Cyan Yellow Magenta	C4820A C4821A C4822A C4823A
Spindle E Assembly	C6078A		

Removal and Installation

8

Right Hand Cover	8-4
Front Panel Assembly	8-6
Right Hand Trim and Window Switch	8-7
Service Station Assembly	8-8
Drop Detector Assembly	8-10
Vacuum Fan	8-11
Paper-axis Motor Assembly	8-12
Left Hand Cover	8-13
Left Hand Trim Assembly	8-18
Ink Supply Station Assembly (ISS)	8-19
Air Pressurization System (APS)	8-20
Clutch Assembly and left hand miscellaneous parts	8-21
Tail Deflectors and Rear Platen	8-23
Left and Right Rear Covers	8-24
Electronics Module	8-25
Media Sensor	8-29
Window	8-30
Top Cover	8-31
Back Cover	8-32
Scan-axis Motor Assembly	8-33
Encoder Strip	8-34
Tensioner	8-37
Trailing Cable	8-39
Cutter Assembly	8-42
Carriage Assembly and Belt	8-44
Tubes System Assembly	8-53
Ink Leak Detector Assembly	8-60
Front Platen Assembly	8-62
Platen Assembly	8-63
Paper Entry Assembly	8-64
Roller Guide	8-66
Media Holder Strip	8-69
Drive Roller	8-70
Center Guide	8-71
Pinch-Wheel Assembly and Cam	8-73

Introduction

This chapter is a step by step guide to the removal and installation of the key components in the printer. You may find it useful to tick off the steps as they are performed. Use the illustration at each procedure to identify the parts referred to in the text.

The procedures appear in order of removal. So the whole machine can be stripped down by starting at the beginning of this chapter and working through the subsequent procedures.

NOTE

Before using this chapter to remove and install a new component, always make sure that you have performed the relevant service test from Chapter 4. If the test passes you will not need to replace the component.

Safety Precautions

(Safety symbols - Immediately after the table of contents.)

Review WARNING and CAUTION symbols and instructions before you service the printer. Follow these warnings and cautions for your protection and to avoid damaging the printer.

WARNING

Serious shock hazard leading to death or injury may result if you do not take the following precautions:

Ensure that the ac power outlet (mains) has a protective earth (ground) terminal.

Switch the plotter off, and disconnect it from the power source prior to performing any maintenance.

Prevent water or other liquids from running onto electrical components or circuits, or through openings in the module.

Electrostatic Discharge (ESD) Precautions

To prevent damage to the Printer circuits from high-voltage electrostatic discharge (ESD):

1. Do not wear clothing that is subject to static build-up.
2. Do not handle integrated circuits (ICs) in carpeted areas.
3. Do not remove an IC or a printed circuit assembly (PCA) from its conductive foam pad or conductive packaging until you are ready to install it.
4. Ground (earth) your body while disassembling and working on the Printer.
5. After removing a cover from the Printer, attach an earthing (ground) lead between the PCA common and earth ground. Touch all tools to earth ground to remove static charges before using them on the Printer.
6. After removing any PCA from the Printer, place it on a conductive foam pad or into its conductive packaging to prevent ESD damage to any ICs on the PCA.

Required Tools

The following tools are required to disassemble and repair the Printer.

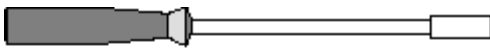
 Long Torx Screwdriver with the indicated attachments

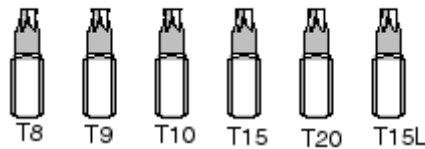

 Nut driver with the indicated attachments

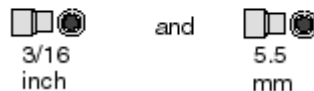

 Small flat-blade screwdriver

Right Hand Cover

Refer to Figure 1

Removal

1. Remove the Printhead Cleaners (Refer to the User Guide).

NOTE

Make sure that the Service Station Carriage is pushed to the back before trying to remove the Right Cover.

WARNING

Switch off the printer and remove the power cable.

1. Remove the following:

1. "Electronics Module Left Rear Cover" see page 8-24.

NOTE

Make sure you take care when removing the ferrite which is attached to the sideplate with a cable tie.

2. Disconnect the front panel cable from position **P16 FRONT PANEL** on the electronics module.

3. Disconnect the aerosol fan cable from position **P7 AEROSOL FAN** on the electronics module.

4. Remove two T-15 screws (item 1) from the right hand trim (item 2).

NOTE

Be careful not to drop the cover (item 3) once the securing fasteners have been removed. Support the cover throughout the next step.

5. Remove two T-15 screws (item 4) from the rear of the right hand cover which are securing the cover to the right hand side chassis.

6. Remove the right hand cover (item 3) by making sure you:

a carefully pull the front panel cable and the aerosol fan cable from a hole in the right hand side chassis.

b disconnect the service station door sensor cable, which hangs down from the service station cable.

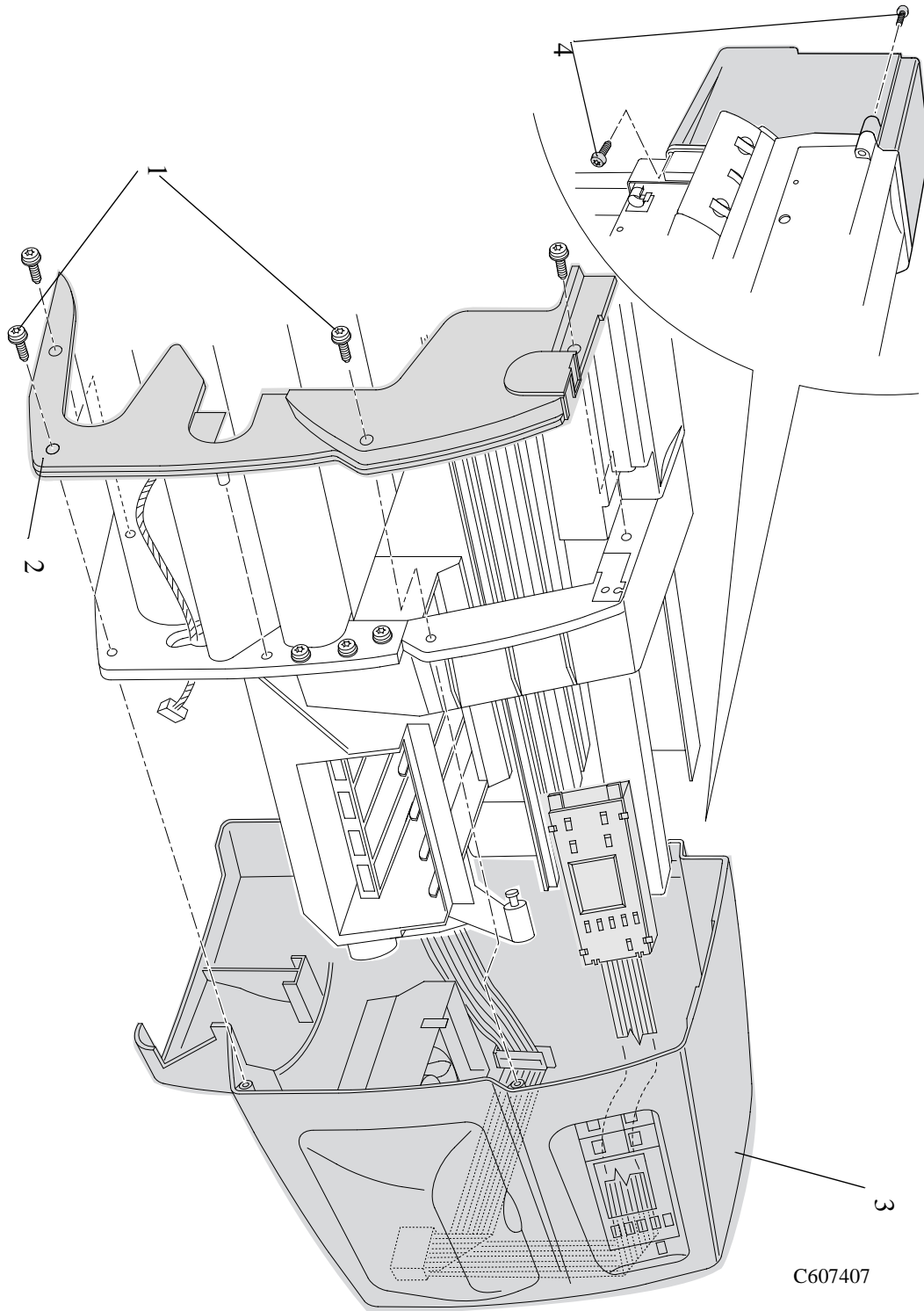

Figure 1: Right Cover

Installation of the Right Hand Cover

NOTE Ensure the front panel cable and the aerosol fan cables are secured inside the right hand cover with cable clamps and retaining clips.

NOTE At the rear of the right hand side chassis is a hole for the cables to go through. If the cables are not through this hole when the cover is in place on the printer the cover cannot be properly installed.

Front Panel Assembly

Removal

1. Remove the Printhead Cleaners (Refer to the User Guide).

WARNING Switch off the printer and remove the power cable.

1. Remove the following:
 1. "Right Hand Cover" see page 8-4.
2. The Front Panel Assembly and the Front-Panel Assembly Cable can be removed by releasing them from the retaining clips (item 1) and cable clamps (item 2) inside the Right Hand Cover (item 3) (Refer to Figure 2).

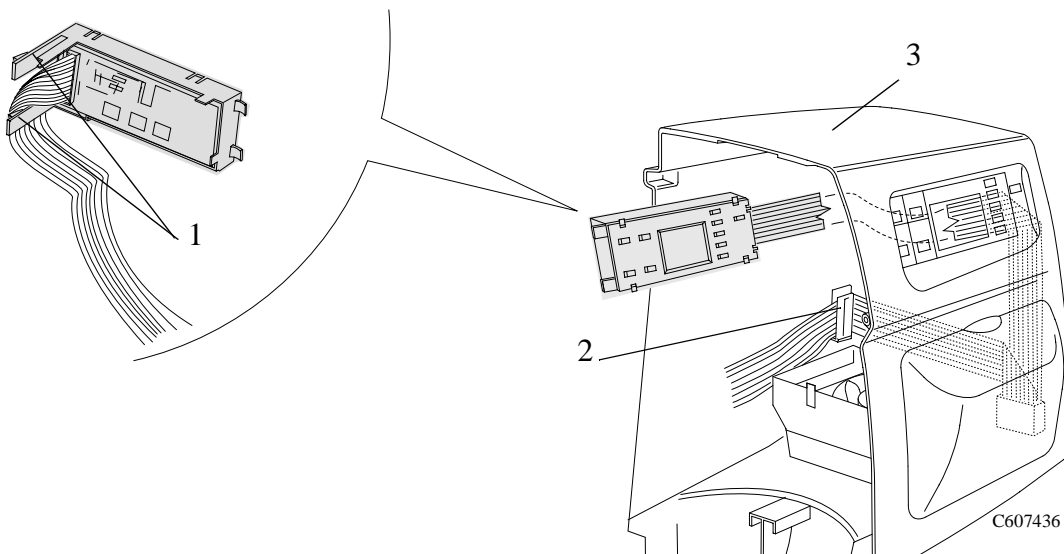

Figure 2: Front Panel

Right Hand Trim and Window Switch

Refer to Figure 3.

Removal

WARNING

Switch off the printer and remove the power cable.

1. Remove the following:
 1. "Right Hand Cover" see page 8-4.
2. Disconnect the Window Switch cable from the Service Station cable.
3. Remove 2 screws (Item 1) that attach the Right Hand Trim (Item 2) to the Printer.
4. Remove the Right Hand Trim (Item 2) from the Printer.

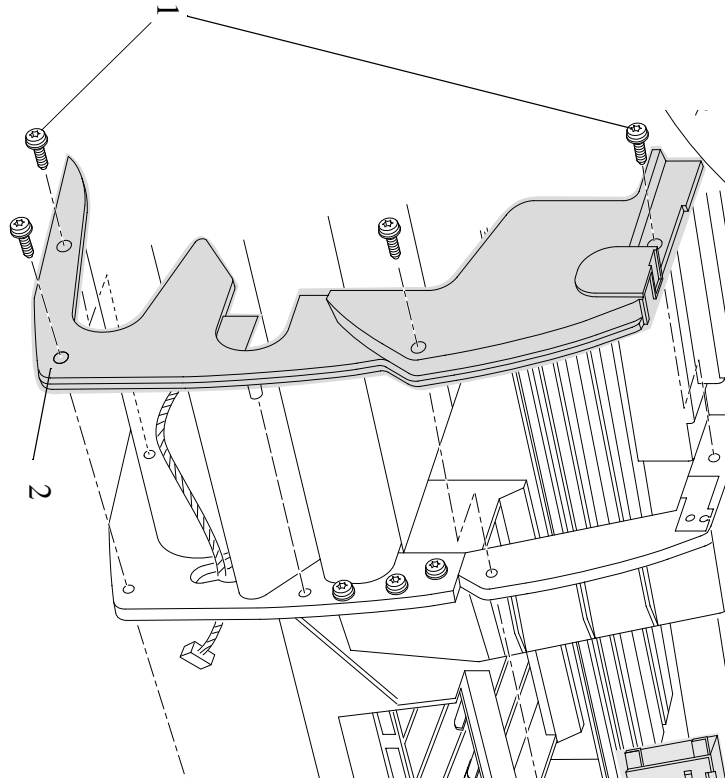

Figure 3: Right Hand Trim

Service Station Assembly

Refer to Figure 4.

Removal

WARNING

Switch off the printer and remove the power cord.

1. Remove the Printhead Cleaners (Refer to the User Guide).
2. Remove the following
 1. "Right Hand Cover" see page 8-4.
3. Disconnect the service station cable from the electronics module out of position **SERVICE STATION**.
4. Disconnect the window switch and right door switch cables from the service station cable.
5. Unclip the Scan-Axis Motor cable from the Service Station.
6. Manually slide the carriage assembly to the middle of the printer.

NOTE

Be careful not to drop the service station (item 2) once the securing fasteners have been removed. Support the service station throughout the following steps.

7. Between the carriage assembly slider rods there are two holes. These holes give you access to two T-15 screws (item 3). Remove the two T-15 screws.
8. Loosen the T-15 screw (item 1) securing the service station to the side of the printer. This screw is long and does NOT need to be fully loosened.

NOTE

When removing the Service Station, make sure that you release the Paper-axis Motor cable from the clip that is located on the Service Station.

9. Lift the service station (item 2) off the loosened screw (item 1) and standing in front of the printer, slide the assembly towards you.

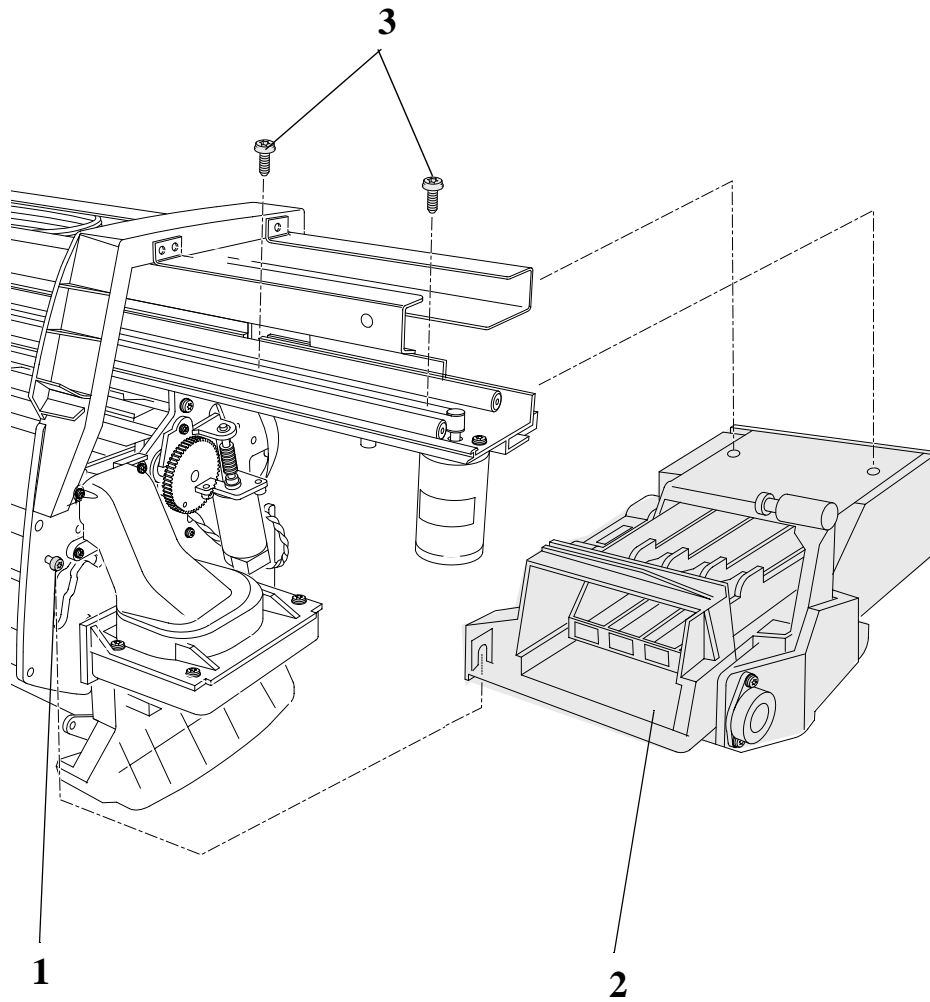

Figure 4: Service Station Assembly

NOTE

You must perform the following Service Calibrations after the installation of the Service Station Assembly.

- Service Station ⇒ Page 5-11.
- Color to Color Calibration ⇒ Page 5-16.

Drop Detector Assembly

Refer to Figure 5.

Removal

WARNING

Switch off the printer and remove the power cord.

1. Remove the Printhead Cleaners (Refer to the User Guide).
2. Remove the following
 1. "Right Hand Cover" see page 8-4.
 2. "Service Station Assembly" see page 8-8.
3. Disconnect the Drop Detector cable from the Service Station Cable.
4. Remove the screw (item 1) that attaches the Drop Detector Assembly (item 2) to the Service Station (item 3).
5. Remove the Drop Detector from the Service Station.

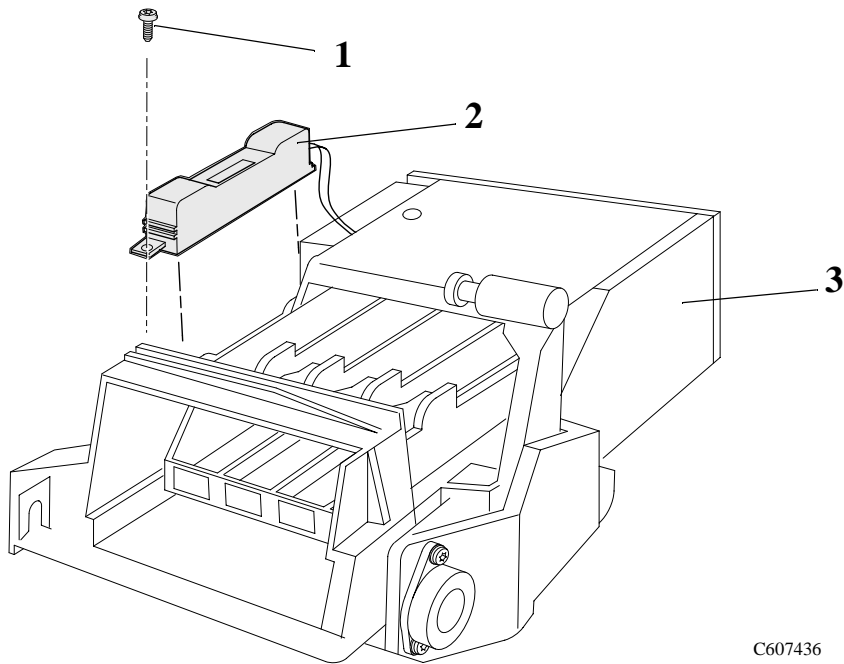

C607436

Figure 5: Drop Detector Assembly

Vacuum Fan

Refer to Figure 6.

Removal

WARNING

Switch off the printer and remove the power cord.

1. Remove the following:
 1. "Right Hand Cover" see page 8-4.
 2. "Service Station Assembly" see page 8-8.
2. Disconnect the vacuum fan cable from position **P7 VACUUM FAN** on the electronics module.
3. Remove the four T-15 screws (item 1) securing the vacuum fan assembly (item 2) to the right hand side chassis and remove the assembly.

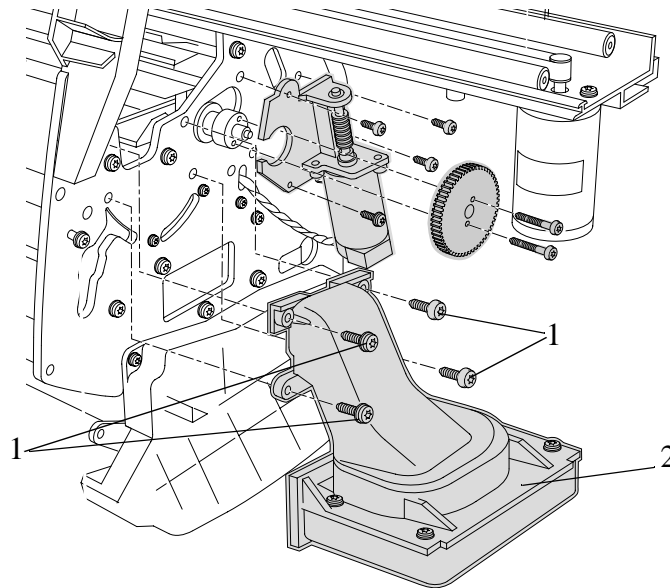

C607421

Figure 6: Vacuum Fan

Paper-axis Motor Assembly

Refer to Figure 7.

Removal

WARNING

Switch off the printer and remove the power cord.

1. Remove the following:
 1. "Right Hand Cover" see page 8-4.
 2. "Service Station Assembly" see page 8-8.
2. Disconnect the Paper-axis Motor cable from position **P3 PAPER MOTOR** on the electronics module.
3. Disconnect the Paper-axis encoder cable from position **P1 PAPER ENCODER** on the electronics module.
4. Remove the two T-10 screws (item 1) securing the gear (item 2) to the right side of the roller and remove the gear.
5. Remove the four T-20 screws (item 3) securing the Paper-axis Motor Assembly (item 4) to the right hand chassis. Remove the Paper-axis Motor Assembly.

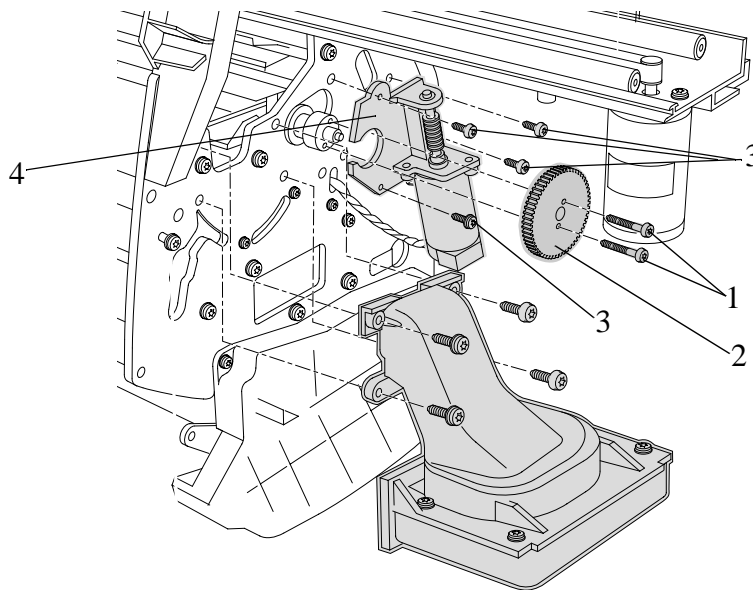

C607421

Figure 7: Paper-axis Motor Assembly

NOTE

You must perform the Accuracy Calibration (⇒ Page 5-6) after the installation of the Paper-Axis Motor Assembly.

Left Hand Cover

Refer to Figure 8 to Figure 15.

Removal

1. Remove the Ink Cartridges (Refer to the User Guide).

WARNING

Switch off the printer and remove the power cord.

NOTE

Working from the rear of the printer.

1. Open the door at the back of the left hand cover by removing the two T-15 screws (item 1) (refer to Figure 8).

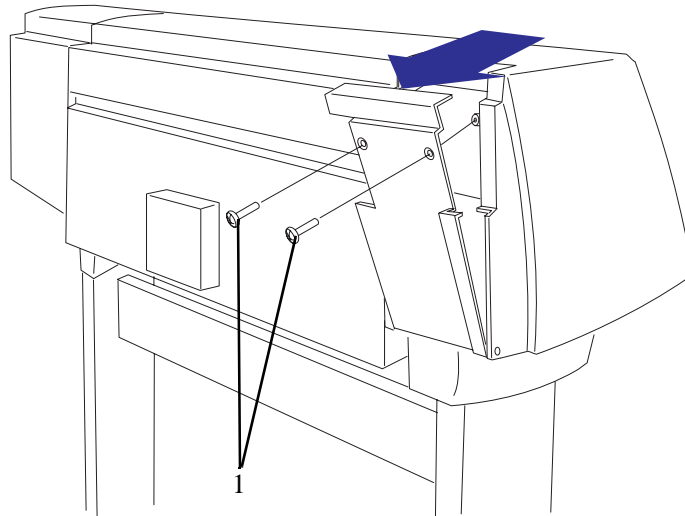

Figure 8: Left Hand Cover

2. Release the tube holder (item 1) from the rear of the left hand cover by pushing it up and out (refer to Figure 9).

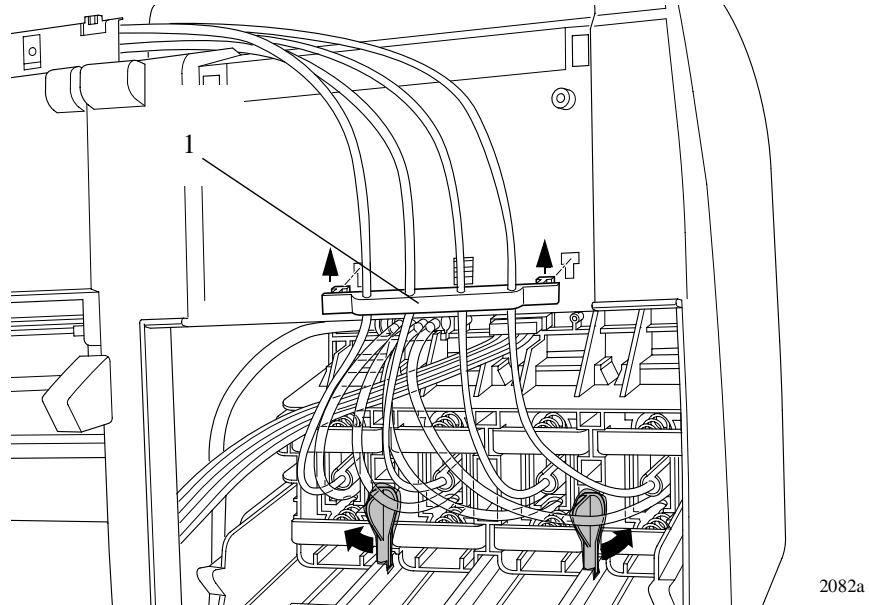

Figure 9: Tube Grip

3. Twist the two latches at the rear of the ink cartridge tube connector outwards (refer to Figure 10). This will release the complete assembly.

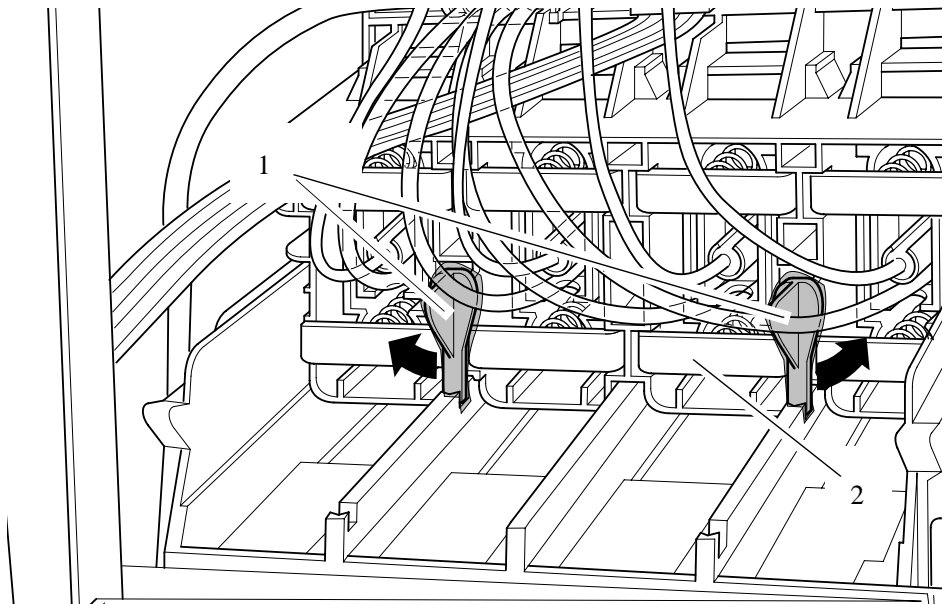

Figure 10: Latches

- Slide the ink cartridge tube connector assembly towards you (refer to Figure 11).

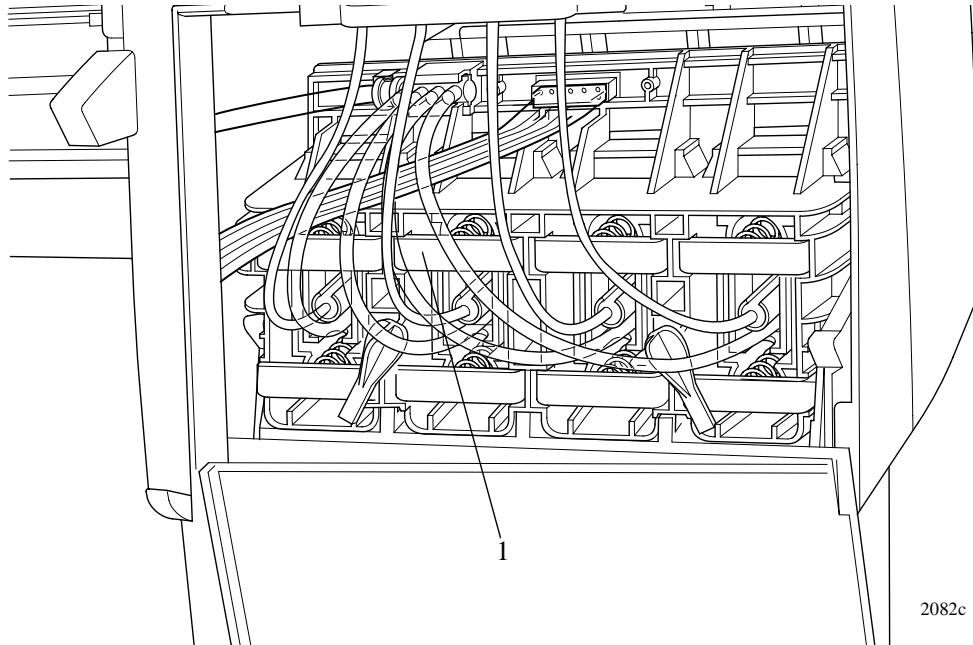

Figure 11: Ink Cartridge Tube Connector (pulled back)

- Disconnect the ink cartridge tube connector cable (refer to Figure 12).

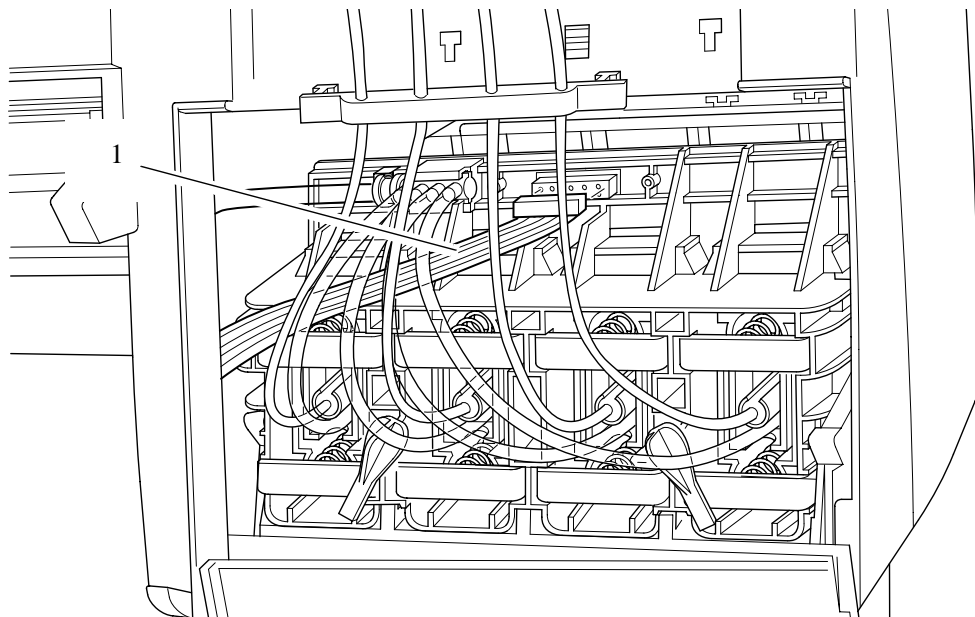

Figure 12: Ink Cartridge Tube Connector Cable

6. Disconnect the air tube (refer to Figure 13).

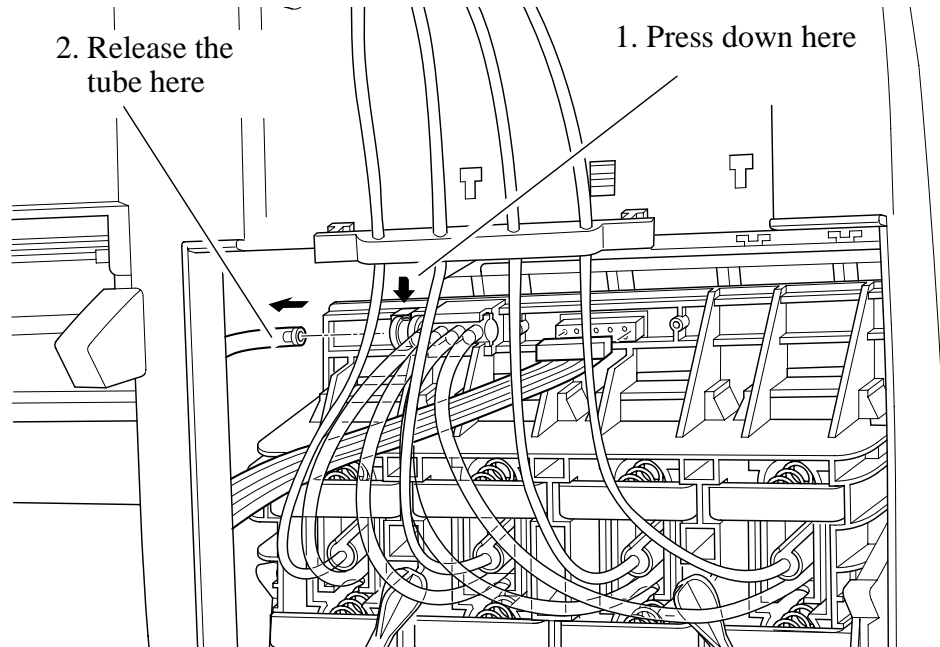

Figure 13: Air Tube

7. Remove the ink cartridge tube connector (item 1) from the rear of the left hand cover (item 2) and store it safely on top of the Printer (refer to Figure 14).

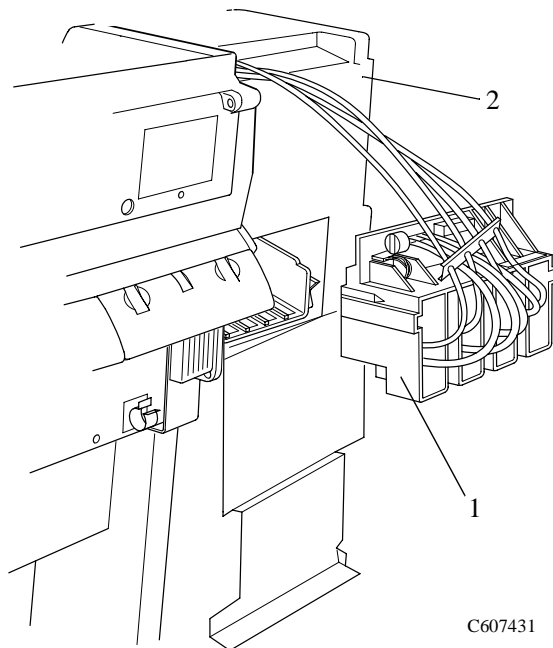

Figure 14: Ink Cartridge Tube Connector (pulled out)

NOTE

In the following steps, refer to Figure 15.

8. Remove two T-15 screws (item 1) from the left hand trim.
9. Remove two T-15 screws (item 2) from the rear of the left hand cover which are securing the cover to the left hand side chassis.

NOTE

Be careful not to drop the cover once the securing fasteners have been removed.

10. Remove the left hand cover (item 3) from the printer.

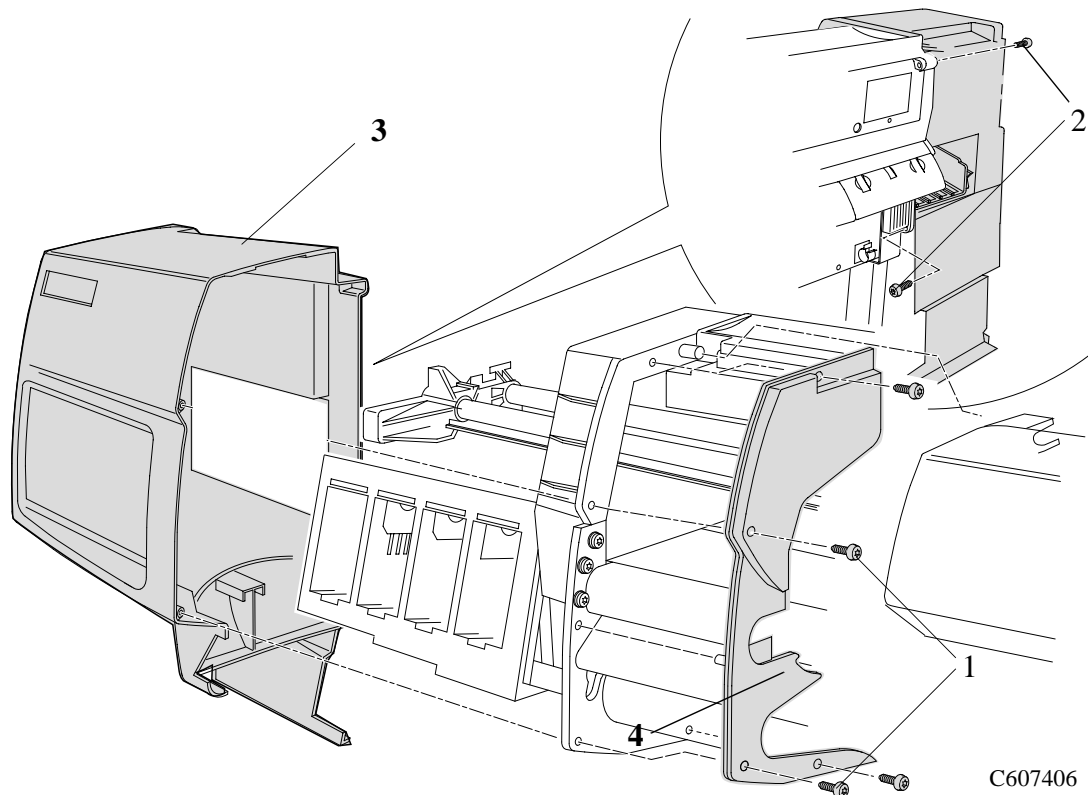

Figure 15: Left Hand Cover

Left Hand Trim Assembly

Refer to Figure 16.

Removal

1. Remove 4 screws (Item 1) that attach the Left Hand Trim (Item 2) to the Printer.
2. Remove the Left Hand Trim (Item 2) from the Printer.

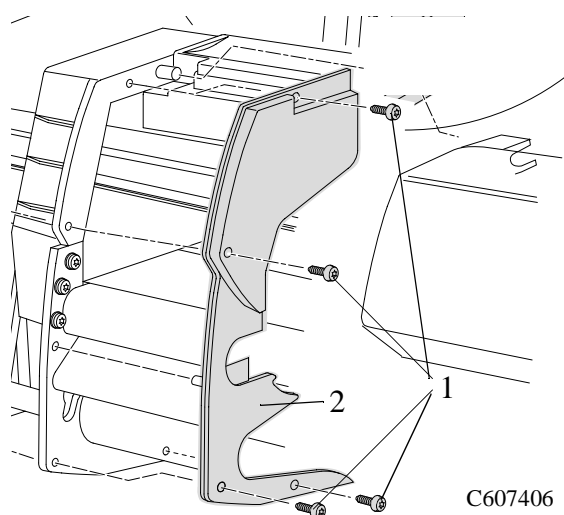

Figure 16: Left Hand Trim

Ink Supply Station Assembly (ISS)

Refer to Figure 17.

Removal

WARNING

Switch off the printer and remove the power cord.

1. Remove the Ink Cartridges (Refer to the User Guide).
2. Remove the following:
 1. "Left Hand Cover" see page 8-13.
 2. "Left Rear Cover" see page 8-24.

NOTE

Working from the rear of the printer.

3. Disconnect all the cables from the right hand side of the electronics module.

NOTE

Working from the front of the printer.

4. Unclip the latch and lift up the front of the assembly to release the front support of the ISS from a hole in the side chassis.
5. Push the ISS away from you to release the back support of the ISS from a second hole in the side chassis.
6. Move the ISS to the left to remove completely.

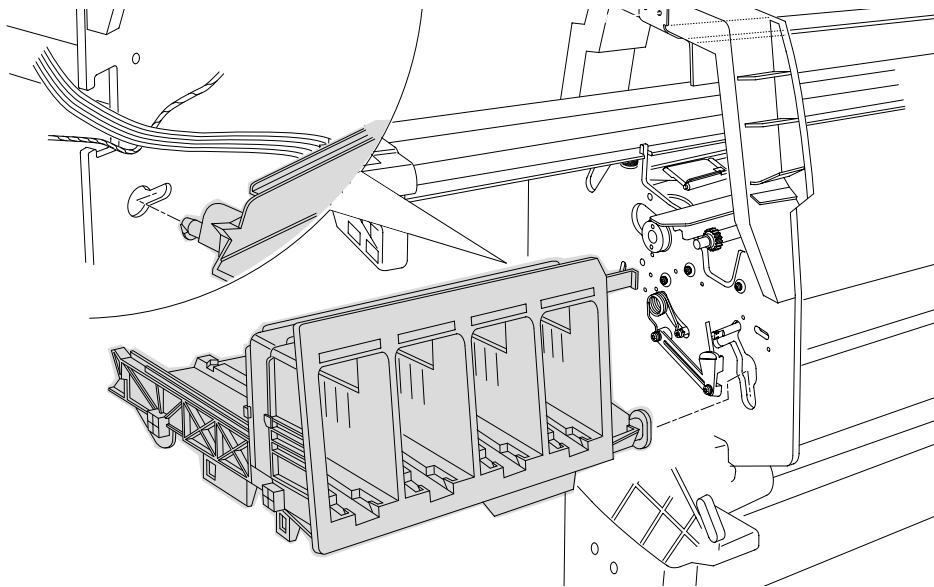

Figure 17: Ink Supply System

Air Pressurization System (APS)

Removal

WARNING

Switch off the printer and remove the power cord.

1. Remove the Ink Cartridges (Refer to the User Guide).
2. Remove the following:
 1. "Left Hand Cover" see page 8-13.
 2. "Ink Supply System" see page 8-19.

NOTE

When removing the APS from the ISS, take care with the tube and cables attached to the ISS.

3. Release the APS from the retaining clips underneath the ISS as shown in Figure 18.

NOTE

If ink in the air system is suspected (Ink Cartridge leakage or depressurization System Error), be very careful when removing the APS because there could be ink in the APS.

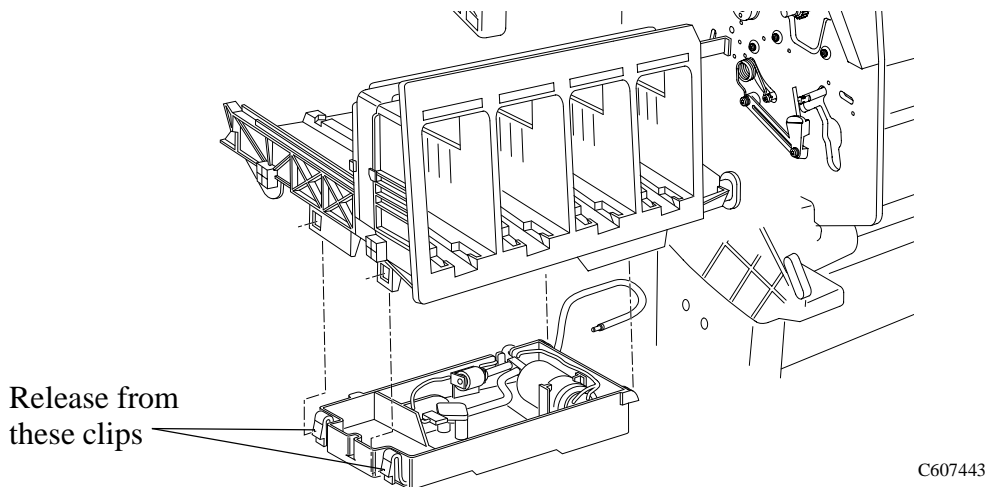

Figure 18: Air Pressurization System

Installation of the Air Pressurization System (APS)

When assembling the APS, make sure that the air tube is correctly routed and not pinched.

NOTE

Perform the Ink Pressure System Test (⇒ Page 4-14) after reinstalling the APS to make sure that it functions correctly.

Clutch Assembly and left hand miscellaneous parts

Refer to Figure 19 and Figure 20.

Removal

WARNING Switch off the printer and remove the power cord.

1. Remove the following:
 1. "Left Hand Cover" see page 8-13.
 2. "Ink Supply System Assembly" see page 8-19.

NOTE From steps 2 to 5, refer to Figure 19.

2. Pull apart the two tabs on the Paper Entry gear (item 1) and remove the gear.
3. Using a long screwdriver remove two T-15 screws (item 5) securing the clutch bracket (item 6) to the side chassis.
4. Remove the special T-20 screw (item 2).

NOTE In the next step the assembly is spring loaded and when the retaining screw is removed it may help to hold the assembly with one hand to avoid losing parts.

5. Remove the gears (item 3) and the spring (item 4) in the clutch assembly. Refer to the note above.

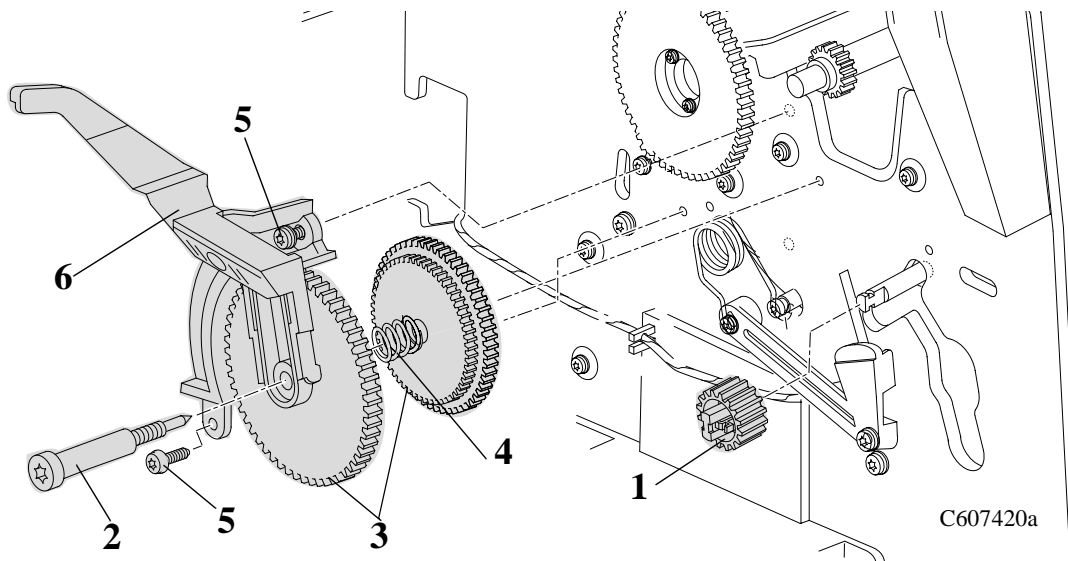

Figure 19: Clutch Assembly

NOTE

For the following steps, refer to Figure 20.

6. Remove the two T-10 screws (item 1) from the left roller gear (item 2) attached to the left side of the roller.
7. Remove the two T-20 screws (item 3) from the roller support (item 4) and remove the support.
8. Release the tension from the torsion spring (item 5) by removing the arm of the spring (item 6) off the spring hook (item 6).
9. Remove the two T-15 screws (item 7) from the pinch sensor bracket (item 8) and remove the bracket with the sensor attached. Release the sensor cable from retaining clips to remove completely.
10. Remove the spring hook (T-15) (item 6).

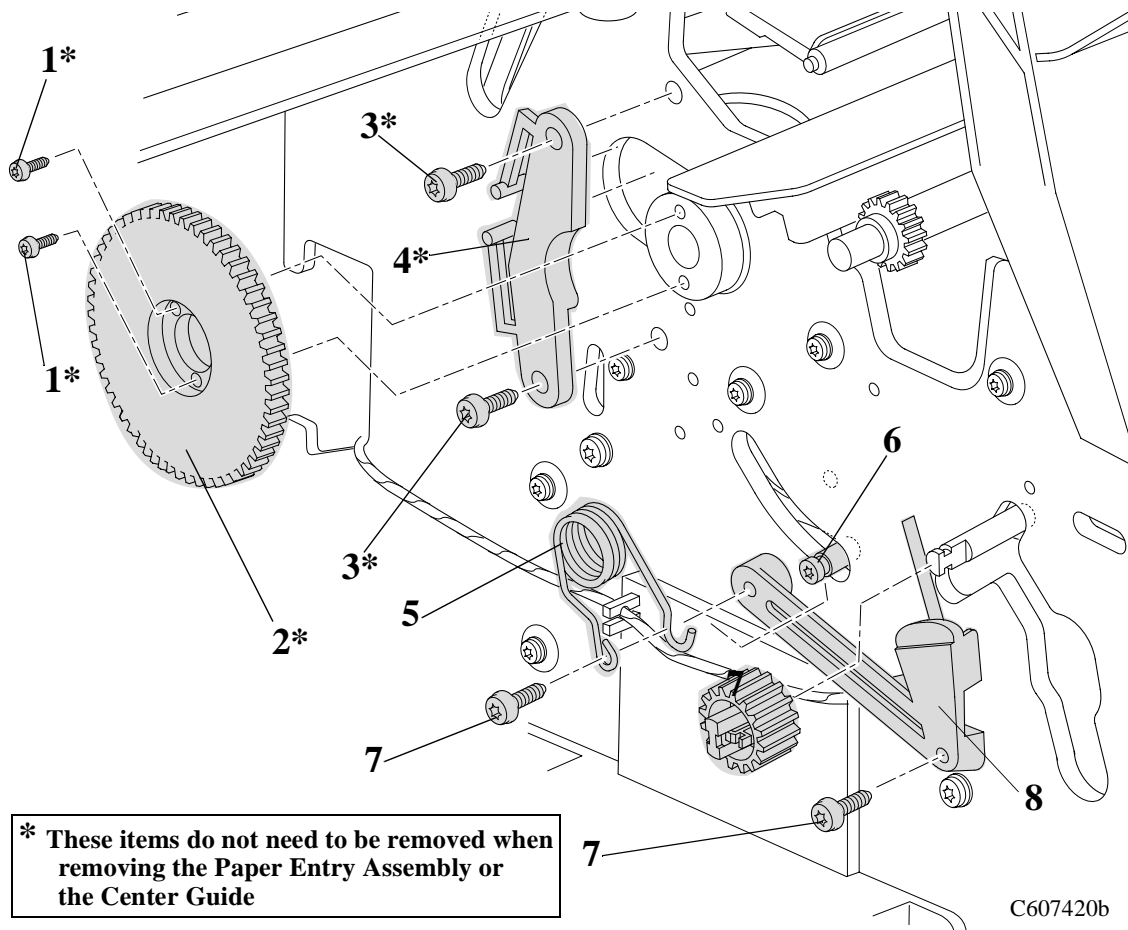

Figure 20: Miscellaneous Parts

Tail Deflectors and Rear Platen

Refer to Figure 21.

Removal

WARNING

Switch off the printer and remove the power cord.

1. Remove the three Deflectors (item 1) by unclipping them from the Rear Platen (Item 3).
2. Remove two T-10 screws (item 2) on the left and right of the Rear Platen (item 3) and remove the platen.

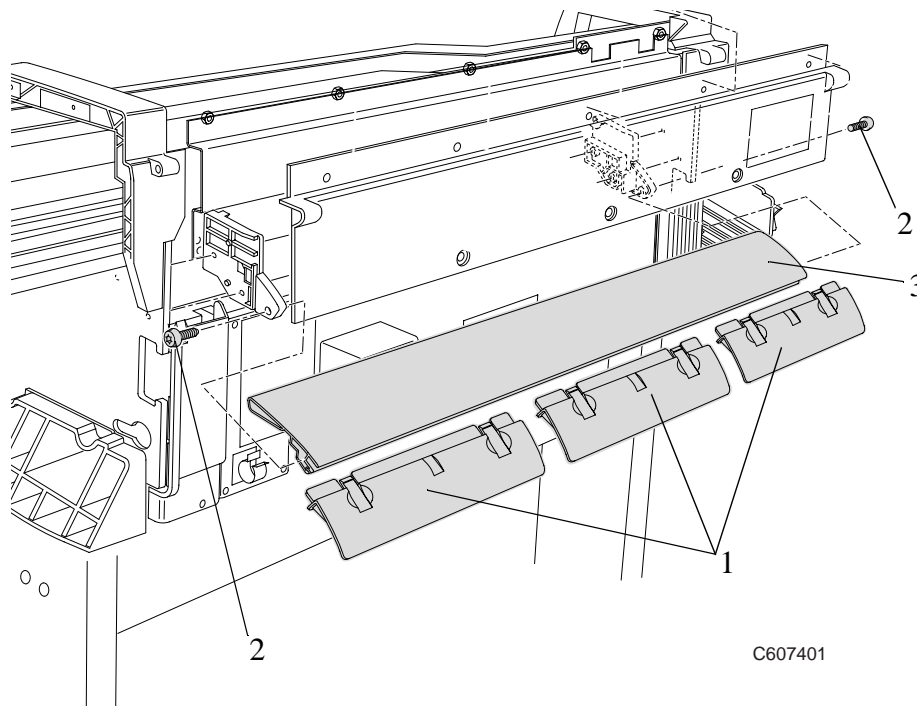

Figure 21: Tail Deflectors and Rear Platen

Left and Right Rear Covers

Refer to Figure 22.

Removal

WARNING

Switch off the printer and remove the power cord.

NOTE

Working from the rear of the Printer.

1. Remove the T-10 Screw (Item 1) that attaches the left hand rear cover (Item 2) to the Printer.
2. Release the left hand rear cover (Item 2) from the retaining clip (item 3) that attaches the ferrite (item 4) to the rear cover.
3. Remove the T-10 Screw (Item 5) that attaches the right hand rear cover (Item 6) to the Printer.
4. Release the right hand rear cover (Item 6) from the retaining clip.

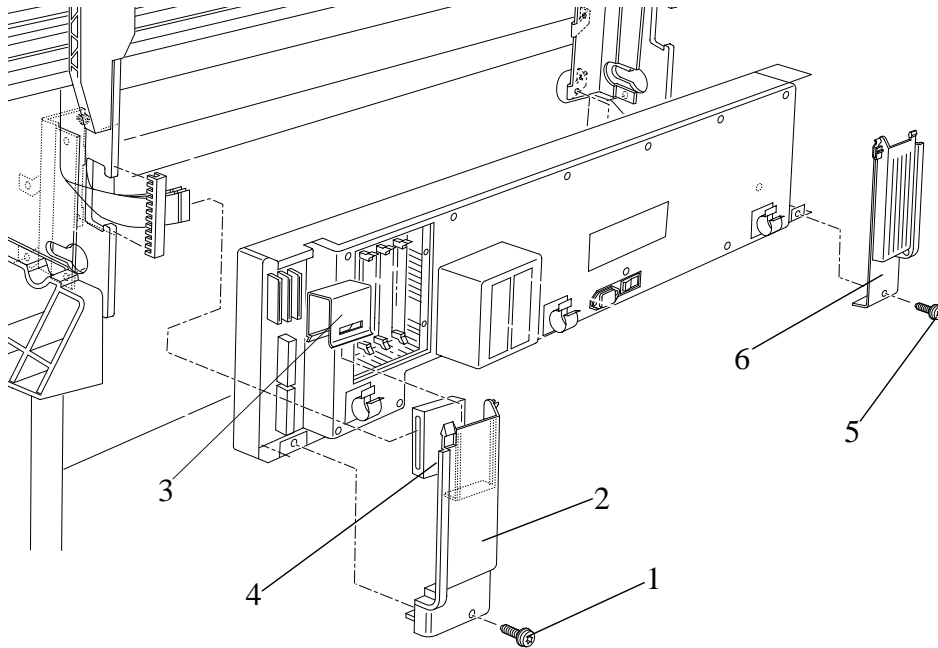

Figure 22: Left and Right Rear Covers

Electronics Module

Refer to Figure 23 and Figure 24.

Removal

WARNING

Switch off the printer and remove the power cord.

NOTE

Working from the rear of the Printer.

1. Remove the following:
 1. "Left and Right Hand Rear Covers" see page 8-24.
 2. "Tail Deflectors and Rear Platen" see page 8-23.

NOTE

For steps 2 to 7, refer to Figure 23.

2. Locate the four T-10 screws (item 1) that secure the DIMM cover (item 2) to the Electronics Module. Remove the four screws and the DIMM cover.

Note the position of the DIMMs. From left to right:

- The DRAM DIMM(s) are held in the 1st and 2nd slot (item 3).
 - The Firmware/Postscript Code DIMM (Flash DIMM) are held in the 3rd slot (Item 4).
3. Remove the DIMMs by releasing the retaining clips at the top and bottom of each one, holding the outer non-metallic edge and gently pulling towards you. Store these parts in a safe place.
 4. With a flat end screwdriver, unscrew the two screws that attach the EIO card (item 5) to the Electronics Module. Remove the EIO card and store in a safe place.
 5. With a flat end screwdriver, unscrew the two screws that attach the Hard Disk Drive (item 6) to the Electronics Module. Remove the Hard Disk Drive and store in a safe place.

WARNING

Be very careful when disconnecting the Trailing Cable from the Electronics Module. Incorrect handling will damage the Trailing Cable and then it will need replacing.

6. Disconnect the Trailing Cable by releasing it from retaining clips in the socket and carefully pulling it towards you.
7. Carefully disconnect all the cables from the left and right side of the electronics module.

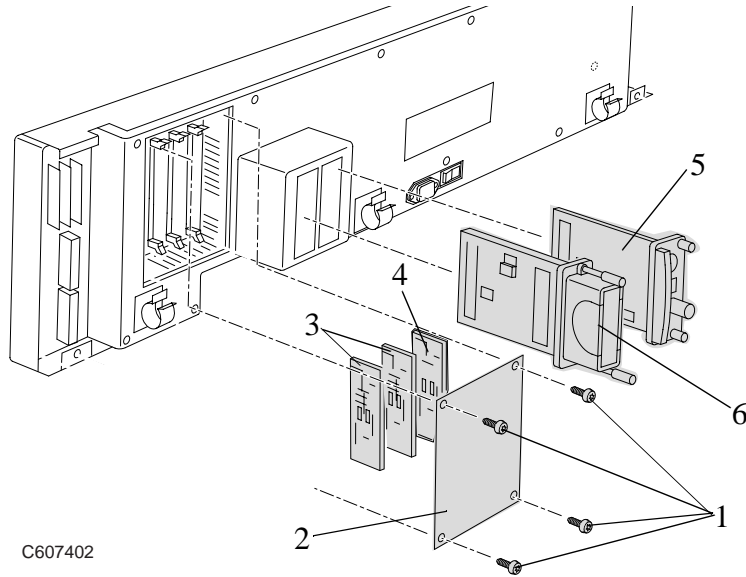

C607402

Figure 23: Electronics Module

NOTE

For the following steps, refer to Figure 24.

8. Remove two T-20 screws (item 1) which can be found at both ends of the electronics module at the bottom.
9. Loosen (do not remove) the two remaining T-20 screws (item 2) and carefully remove the whole electronics module (item 3) by sliding it up and pulling towards you.

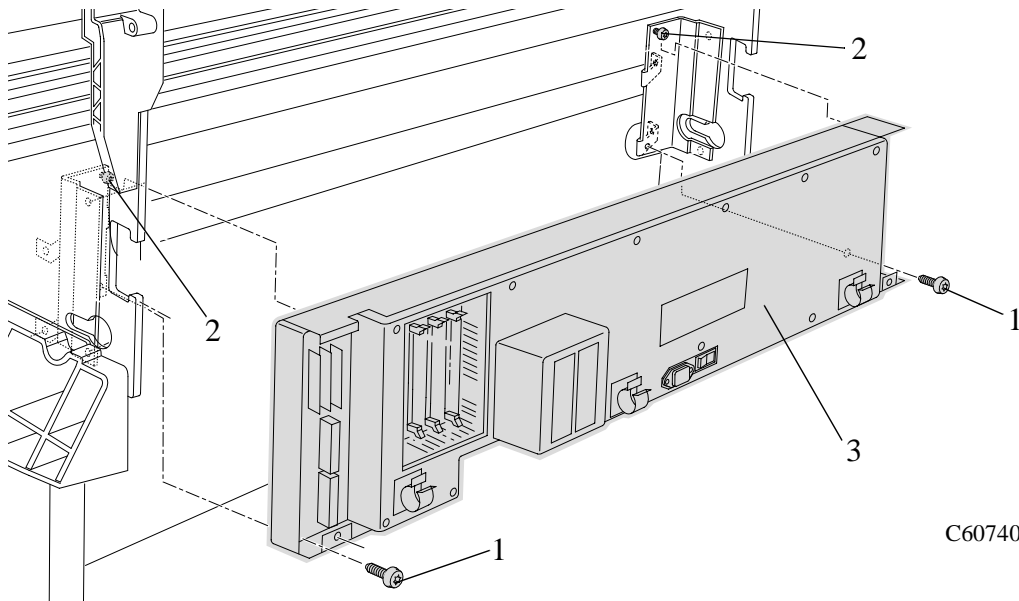

C607403

Figure 24: Electronics Module

Installation of the Electronics Module

WARNING

When reconnecting the Trailing Cable to the Electronics Module, make sure you connect it correctly as follows:

1. Start reconnecting the Trailing Cable from left to right (the longest strip will be connected to the 1st clip from the right).
2. Make sure you push the Trailing Cable in straight and not bent. Once the Trailing Cable is inserted, you should hear an audible click.
3. When the Trailing Cable is inserted correctly, the shaded part (as shown below) will **not** be visible.
4. Before powering ON the Printer, check the continuity (using a tester) between the two points (as shown below).
 - If there is **continuity** between the two points, then the Trailing Cable is installed **incorrectly**. Do **NOT** power ON the Printer because you will burn an internal Electronics Module fuse. Disconnect the Trailing Cable and reconnect again using the above steps.
 - If there is **no continuity** between the two points, then it is possible to power ON the Printer without burning the internal Electronics Module fuse, but there is a possibility that you may still get the System Error Code 0B0006, in which case you have to reconnect the Trailing Cable using the above steps.

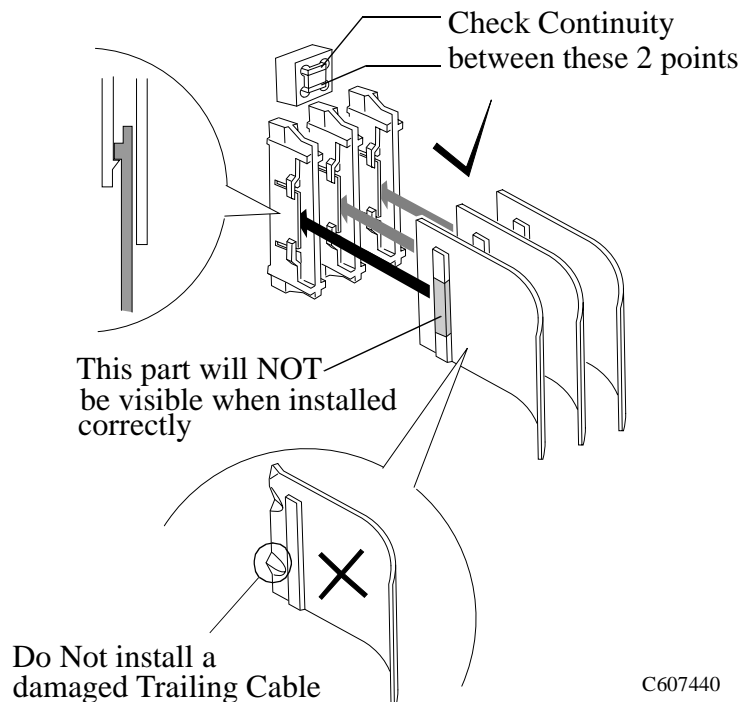

NOTE

You must perform the following Service Calibration and Utility after the installation of the Electronics Module.

- Set Asian PS Fonts (only in Asia) ⇒ Page 4-33.
- Calibrations Backup ⇒ Page 5-19 & Pen Alignment ⇒ Page 5-22.

Media Sensor

Removal

WARNING

Switch off the printer and remove the power cord.

1. Remove the following:
 1. "Center Guide" see page 8-71.
2. Carefully remove the media sensor (item 2) from underneath the center guide (item 1) (refer to Figure 25).

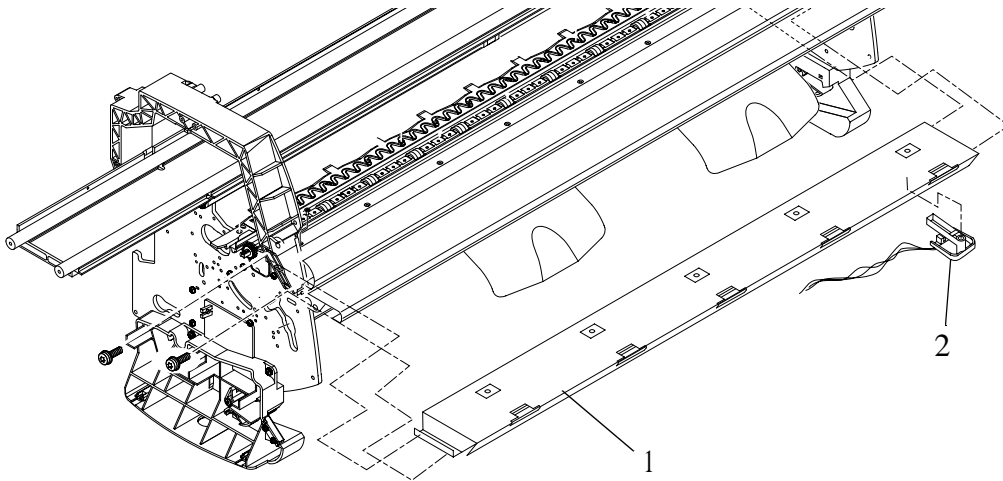

Figure 25: Media Sensor

NOTE

You may also be able to remove the Media Sensor as follows:

1. Remove the following:
 1. "Electronics Module" see page 8-25.
2. Reach underneath the Center Guide and carefully remove the media sensor by pulling it gently down.

Window

Refer to Figure 26.

Removal

WARNING

Switch off the printer and remove the power cord.

1. Open the window and holding both sides pull up to remove.

NOTE

The Window hinges must be vertical when pulling up.

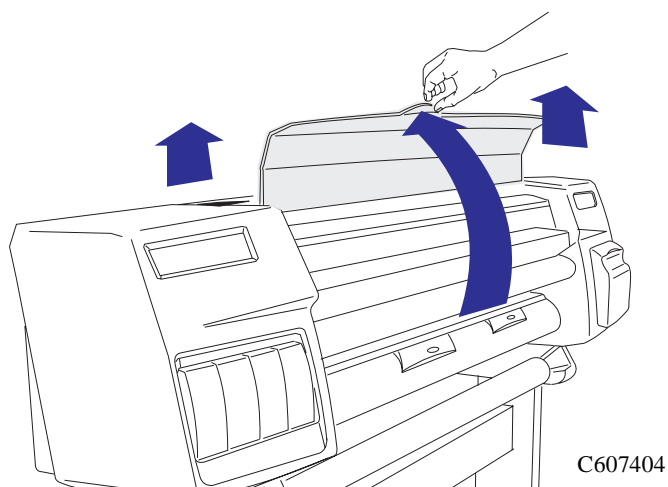

Figure 26: Window

Top Cover

Refer to Figure 27.

Removal

WARNING Switch off the printer and remove the power cord.

1. Remove one T-15 screw (Item 1) from the front of the top cover (item 2).
2. Remove five T-15 screws (item 3) from the rear of the top cover.
3. The top cover (Item 2) can now be released from retaining clips and then removed.

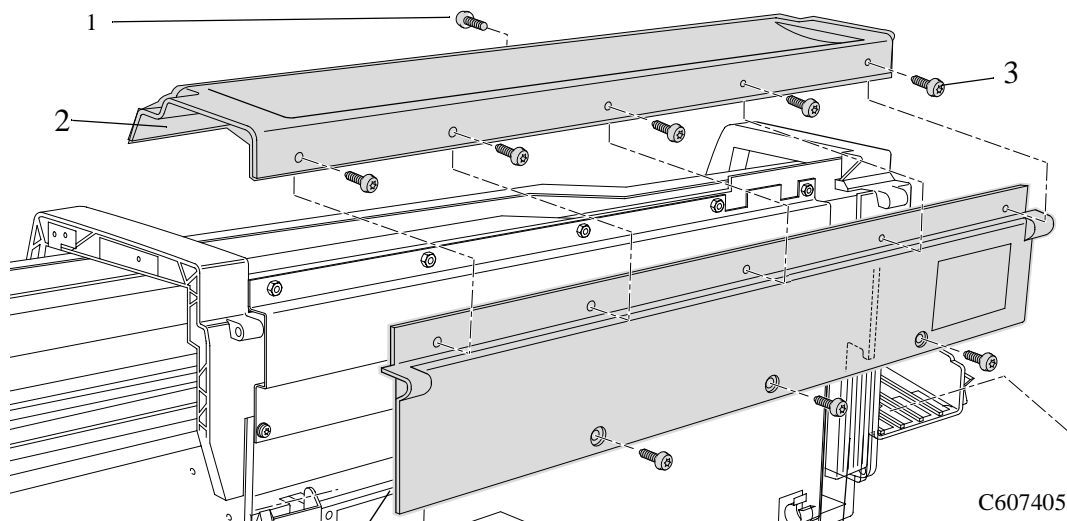

Figure 27: Top Cover

Back Cover

Refer to Figure 28.

Removal

WARNING

Switch off the printer and remove the power cord.

1. Remove the following:
 1. "Top Cover" see page 8-31.
2. Remove three T-15 screws (item 1) from the bottom of the back cover (item 2). Lift the back cover up and remove.

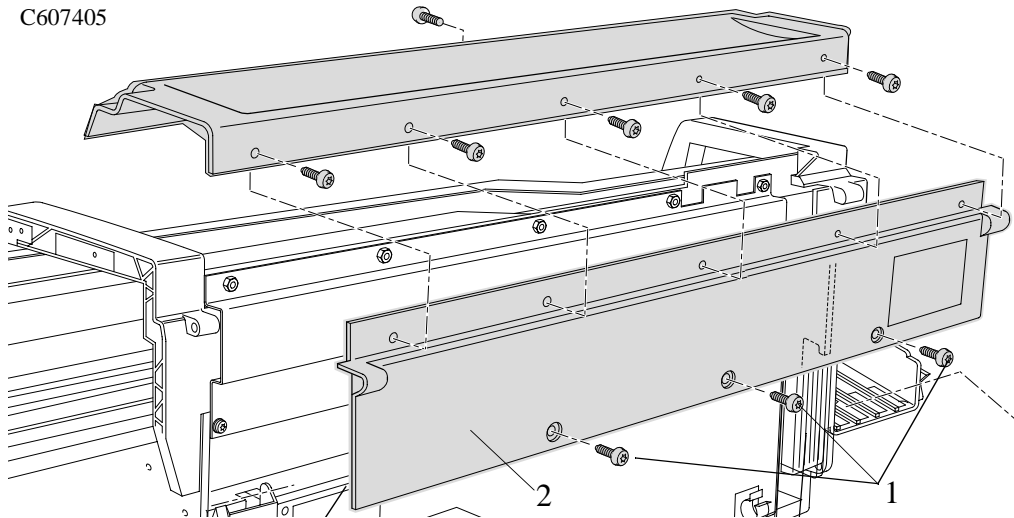

Figure 28: Back Cover

Scan-axis Motor Assembly

Refer to Figure 29.

Removal

WARNING

Switch off the printer and remove the power cord.

1. Remove the following:
 1. "Right Hand Cover" see page 8-4.
 2. "Left Rear Cover" see page 8-24.
2. Disconnect the scan motor cable from position **P3 SCAN MOTOR** in the electronics module.
3. Remove the two T-15 screws (item 1) that attach the Scan-axis motor (item 2) to the Chassis.
4. Hold the Scan-axis motor at an angle, just enough so that the belt (item 3) can be taken off.
5. Remove the Scan-axis Motor from the printer.

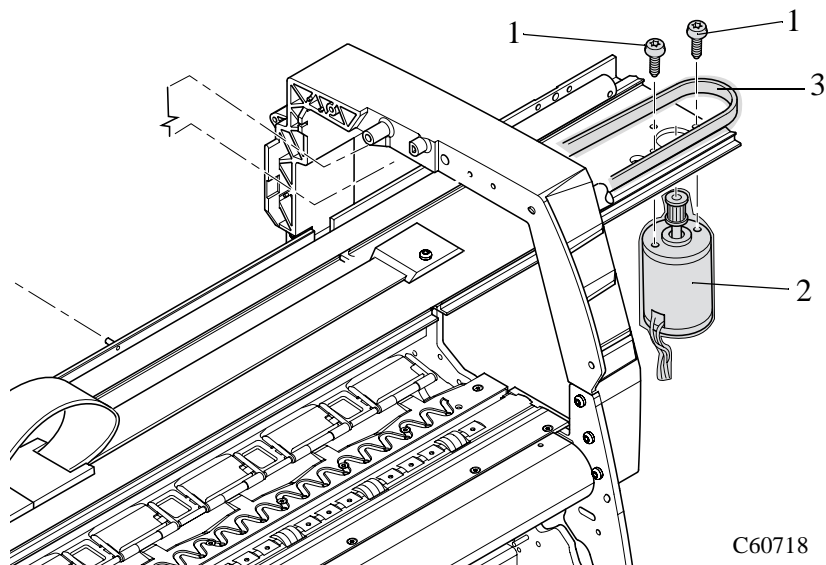

Figure 29: Scan-axis Motor Assembly

Encoder Strip

Refer to Figure 30 to Figure 32.

Removal

WARNING Switch off the printer and remove the power cord.

1. Remove the following
 1. "Left Hand Cover" see page 8-13.
 2. "Right Hand Cover" see page 8-4.
 3. "Back Cover" see page 8-32.

CAUTION To prevent damage to the encoder strip, hold it at the ends only.

NOTE Working from the rear of the printer.

NOTE For steps 2 and 3, refer to Figure 30.

2. Remove five 7mm nuts (item 1) from the EMC Cover (item 2).
3. Remove two T-15 screws (item 3) from the EMC Cover and remove the plate.

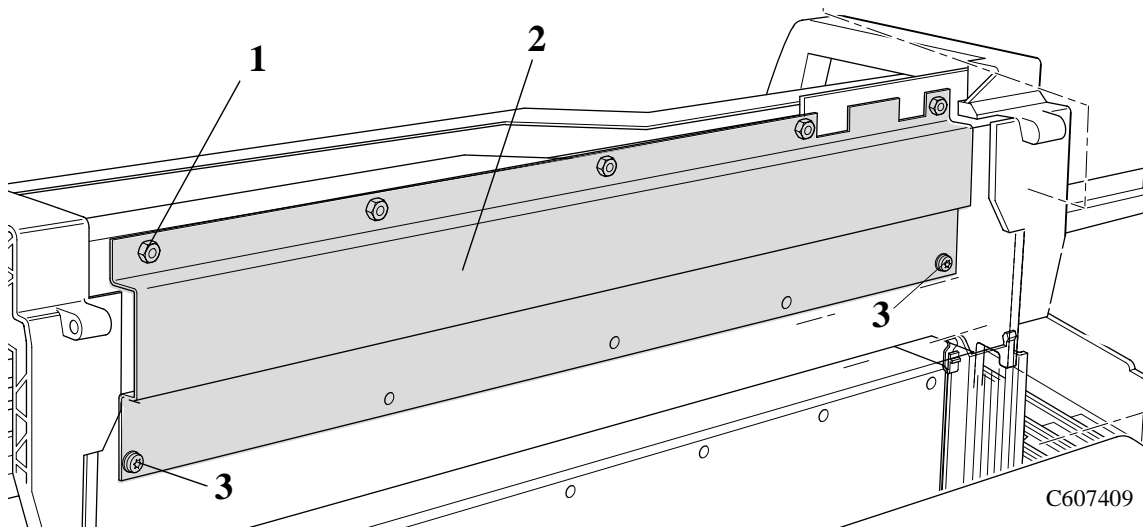

Figure 30: Encoder Strip

NOTE

For steps 4 and 5, refer to Figure 31.

4. Remove the 5.5mm nut (item 1) from the left side of the Printer that attaches the Encoder Strip (item 3) to Spring Clip (item 2).

NOTE

To perform the next step use a screw driver to press the spring clip (item 2) in towards the middle of the printer.

5. Release the Encoder Strip (item 3) from the retaining pin (item 4) on the Spring Clip (item 2).

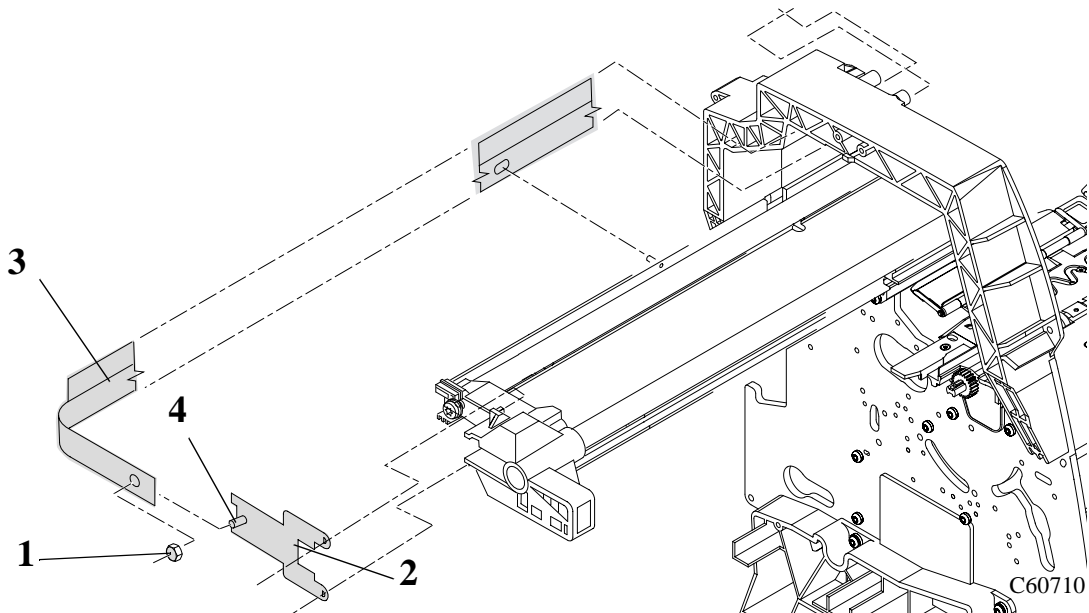

Figure 31: Encoder Strip

NOTE

For the following steps, refer to Figure 32.

6. Remove the 5.5mm nut (item 1) from the right side of the printer securing the encoder strip (item 2).
7. Remove the encoder strip from retaining pins (item 3) on the right side of the Printer Chassis.
8. Remove the encoder strip spacer (item 4).
9. Release the encoder strip from the carriage assembly.
10. Release the encoder strip from all the retaining pins (item 5) along the back of the printer.
11. The encoder strip can now be removed from the printer.

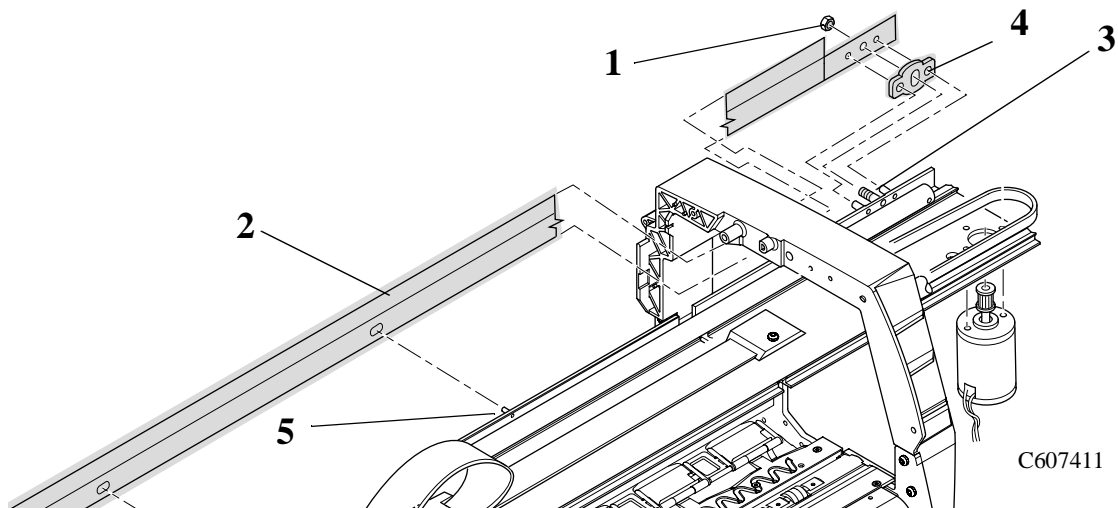

Figure 32: Encoder Strip

Tensioner

Refer to Figure 33 to Figure 35.

Removal

WARNING

Switch off the printer and remove the power cord.

1. Remove the following
 1. "Left Hand Cover" see page 8-13.
2. To release the tension on the belt (item 1) from the left hand side of the Printer, squeeze the spring (item 2) using the tensioner wedge clip (item 3) until you hear it click into place (refer to Figure 33).

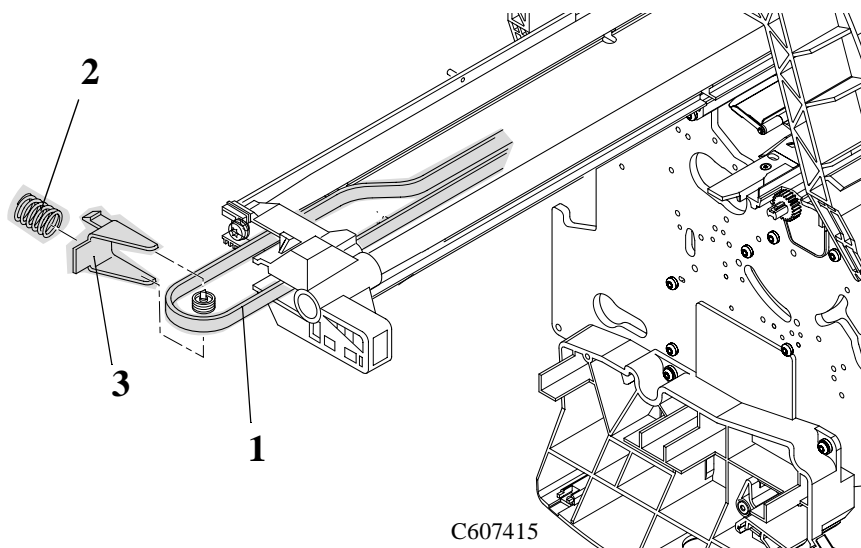

Figure 33: Tensioner Assembly

3. Remove the belt (item 1) from the belt motor pulley (item 2) on the right hand side of the Printer (refer to Figure 34)

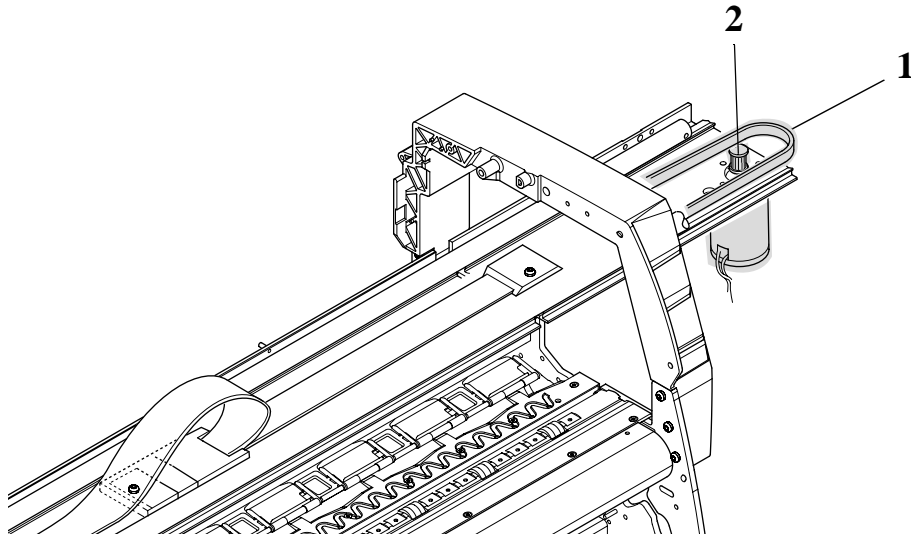

Figure 34: Tensioner Assembly

NOTE

For steps 4 to 6, refer to Figure 35.

4. Remove the tensioner pulley (item 1) from the belt (item 2) which is located in the tensioner assembly (item 3).
5. Remove the two T-15 screws (item 4) securing the tensioner assembly to the slider rods (item 5).
6. Remove the tensioner assembly (item 3).

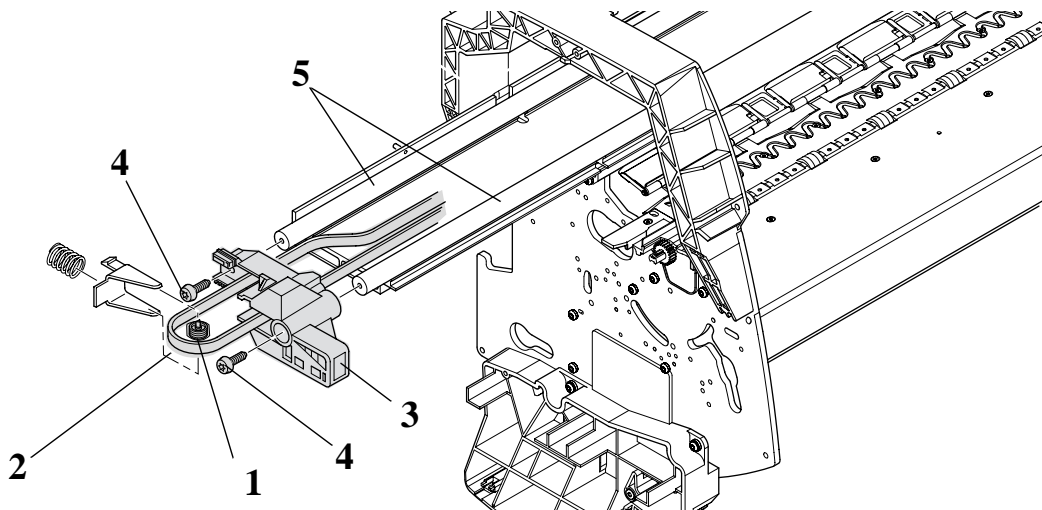

Figure 35: Tensioner Assembly

Trailing Cable

Refer to Figure 36 and Figure 37.

Removal

WARNING

Switch off the printer and remove the power cord.

1. Remove the following:
 1. "Right Hand Cover" see page 8-4.
 2. "Left Hand Cover" see page 8-13.
 3. "Left Rear Cover" see page 8-24.

NOTE

For steps 2 to 5, refer to Figure 36.

2. Manually slide the carriage (item 1) to the left side of the printer.
3. Unclip and remove the trailing cable restraining clip (item 2).
4. Carefully disconnect the trailing cable (item 3) from connectors in the Carriage PCA (item 4).
5. Remove the trailing cable from the trailing cable holder (item 5).

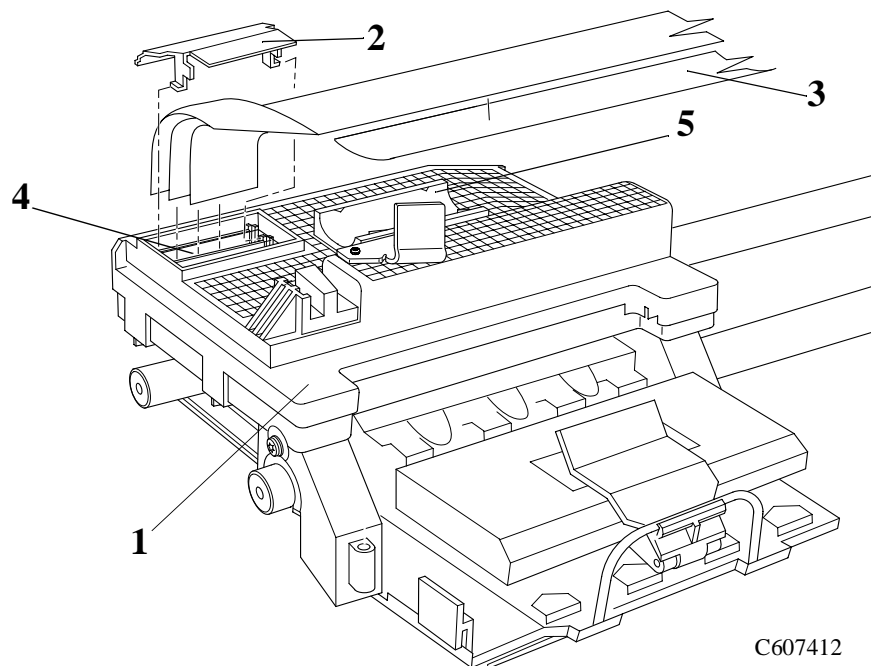

C607412

Figure 36: Trailing Cable

NOTE

For the following steps, refer to Figure 37.

6. Remove the T-15 screw (item 1) from the trailing cable holder (item 2) and remove.
7. Remove two T-10 screws (item 3) from the trailing cable clamp (item 4). Remove the trailing cable clamp (item 4).

WARNING

Be very careful when disconnecting the Trailing Cable from the Electronics Module. Incorrect handling will damage the Trailing Cable and then it will need replacing.

8. Carefully disconnect the trailing cable from the electronics module and pull the trailing cable away from the printer.

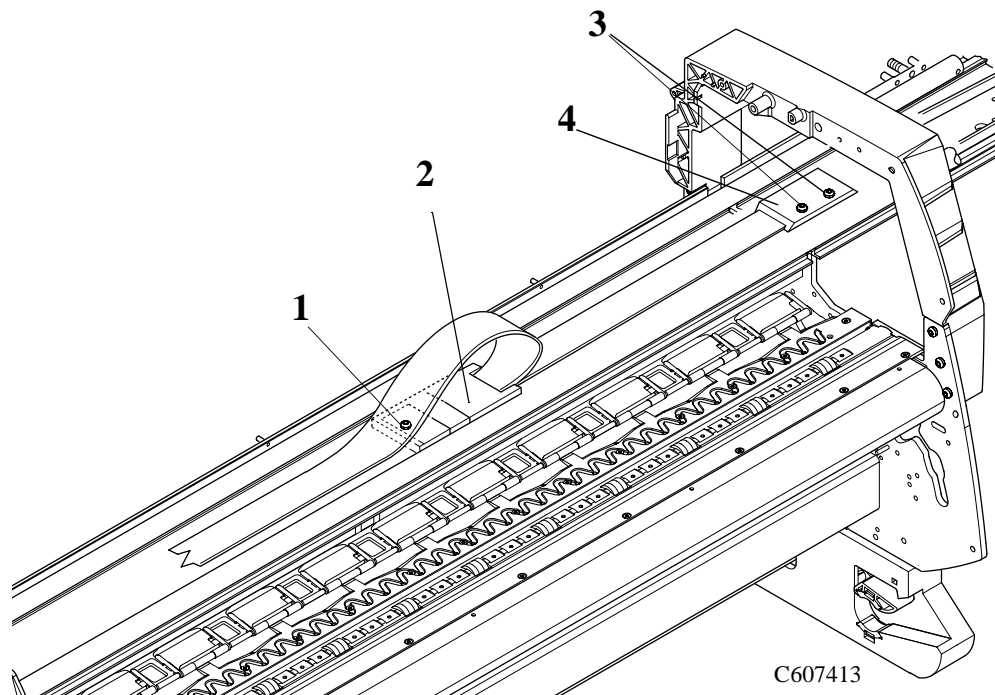

Figure 37: Trailing Cable

Installation of the Trailing Cable

WARNING

When reconnecting the Trailing Cable to the Electronics Module, make sure you connect it correctly as follows:

1. Start reconnecting the Trailing Cable from left to right (the longest strip will be connected to the 1st clip from the right).
2. Make sure you push the Trailing Cable in straight and not bent. Once the Trailing Cable is inserted, you should hear an audible click.

3. When the Trailing Cable is inserted correctly, the shaded part (as shown below) will **not** be visible.
4. Before powering ON the Printer, check the continuity (using a tester) between the two points (as shown below).
 - If there is **continuity** between the two points, then the Trailing Cable is installed **incorrectly**. Do **NOT** power ON the Printer because you will burn an internal Electronics Module fuse. Disconnect the Trailing Cable and reconnect again using the above steps.
 - If there is **no continuity** between the two points, then it is possible to power ON the Printer without burning the internal Electronics Module fuse, but there is a possibility that you may still get the System Error Code 0B0006, in which case you have to reconnect the Trailing Cable using the above steps.

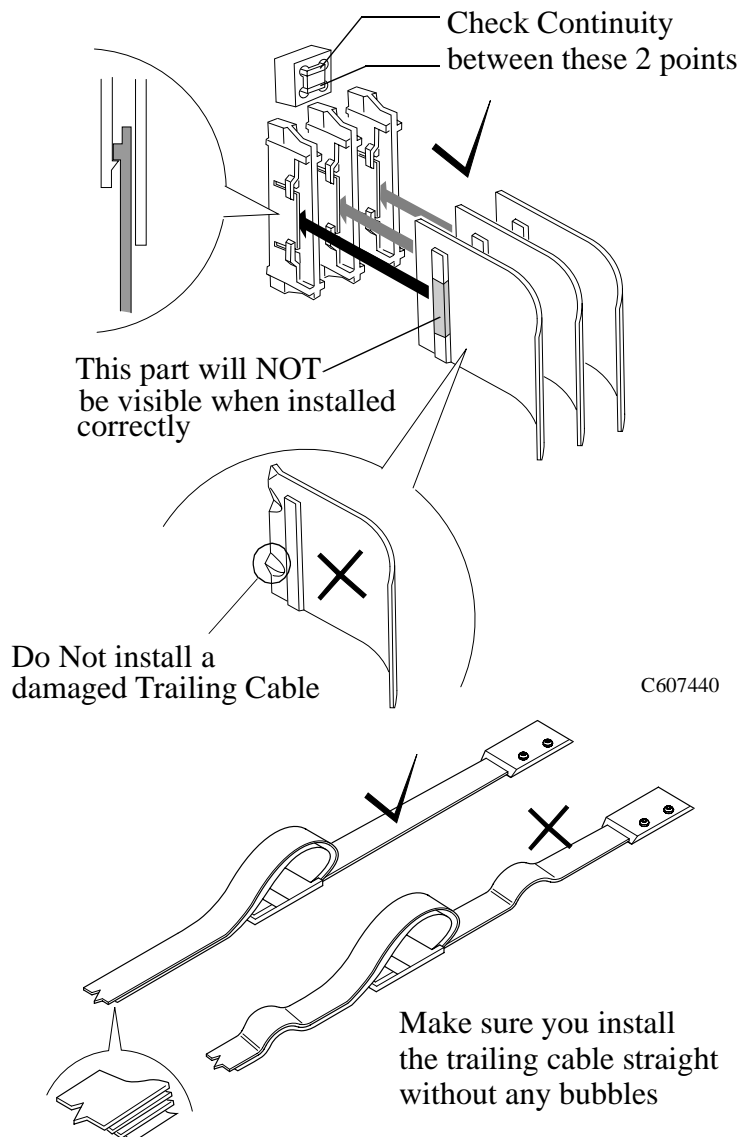

Cutter Assembly

Refer to Figure 38 to Figure 40.

Removal

WARNING Switch off the printer and remove the power cord.

1. Remove the following:
 1. "Top Cover" see page 8-31.
2. Move the carriage to a position where you can access the printhead tube connector (refer to Figure 38).

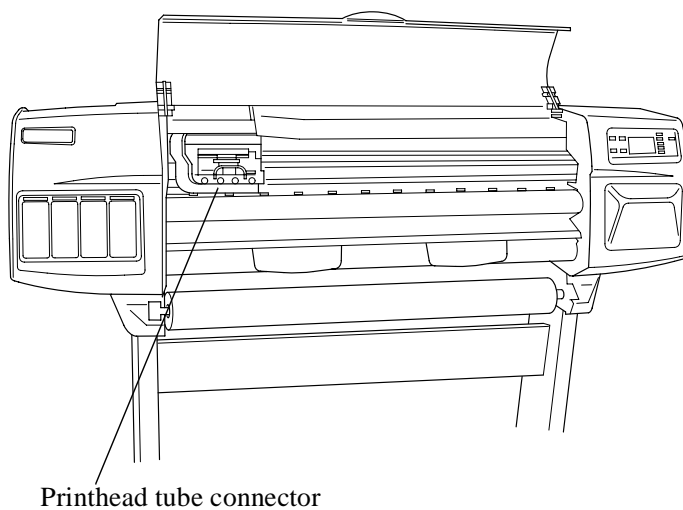

Figure 38: Cutter Assembly

NOTE

For steps 3 and 4, refer to Figure 39

3. Loosen the retaining screw T-9 at the back of the printhead tube connector.
4. Remove the printhead tube connector (refer to Figure 39).

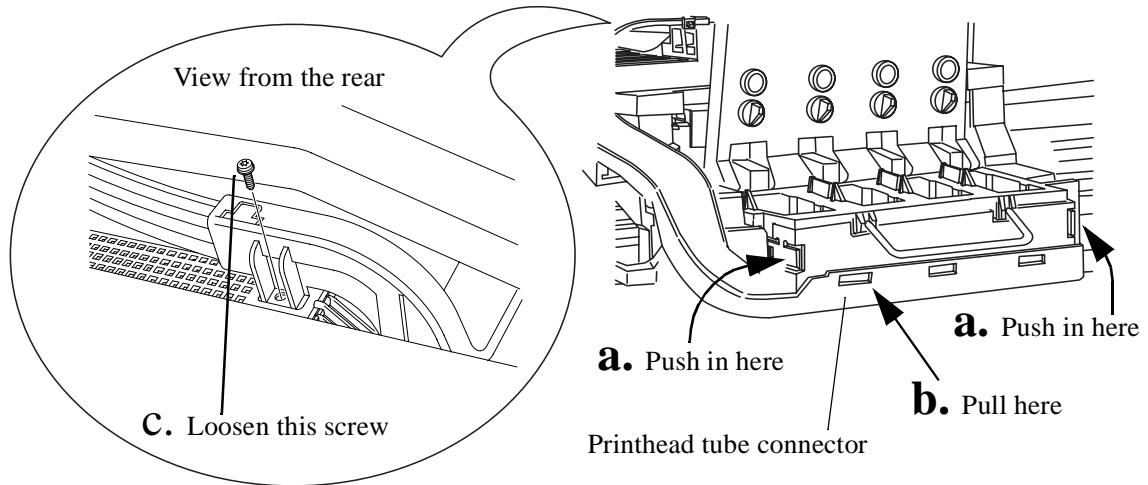

Figure 39: Cutter Assembly

5. Move the Printhead tube connector to a safe position.

NOTE

For the following steps, refer to Figure 40.

6. Remove one screw (item 1) and washer (item 2) that attaches the Cutter Assembly (item 3) to the Carriage Assembly (item 4).
7. Slide the Cutter Assembly (item 3) towards you and remove from the Printer.

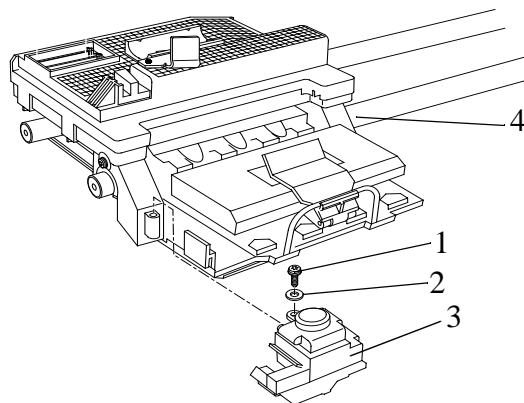

C607417a

Figure 40: Cutter Assembly

Carriage Assembly and Belt

Refer to Figure 41 to Figure 51.

Removal

WARNING

Switch off the printer and remove the power cord.

1. Remove the following:
 1. "Top Cover" see page 8-31.
 2. "Right Hand Cover" see page 8-4.
 3. "Left Hand Cover" see page 8-13.
2. Move the carriage to a position where you can access the printhead tube connector (refer to Figure 41).

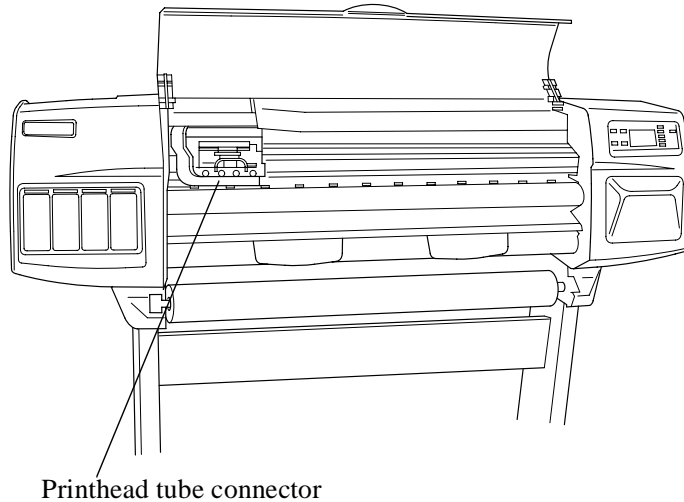
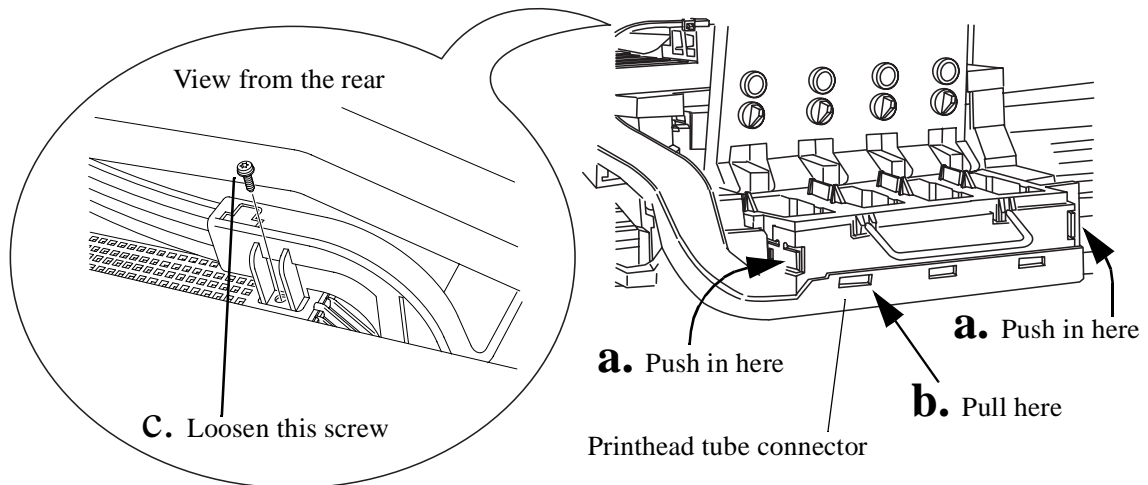

Figure 41: Carriage Assembly and Belt

NOTE**For steps 3 and 4, refer to Figure 42.**

3. Loosen the retaining screw T-9 at the back of the printhead tube connector.
4. Remove the printhead tube connector (refer to Figure 42).

**Figure 42: Carriage Assembly and Belt**

5. Move the Printhead tube connector to a safe position.

NOTE

For steps 6 to 8, refer to Figure 43.

6. Unclip and remove the trailing cable restraining clip (item 2) from the Carriage Assembly (item 1).
7. Carefully disconnect the trailing cable (item 3) from connectors in the Carriage PCA (item 4).
8. Remove the trailing cable (item 3) from the trailing cable holder (item 5).

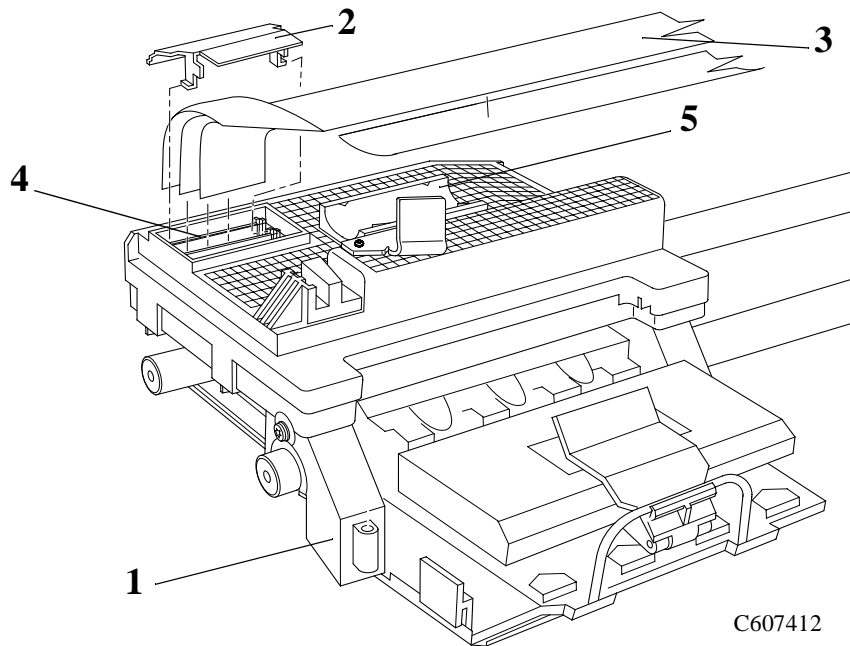

Figure 43: Carriage Assembly and Belt

9. To release the tension on the belt (item 1) from the left hand side of the Printer, squeeze the spring (item 2) using the tensioner wedge clip (item 3) until you hear it click into place (refer to Figure 44).

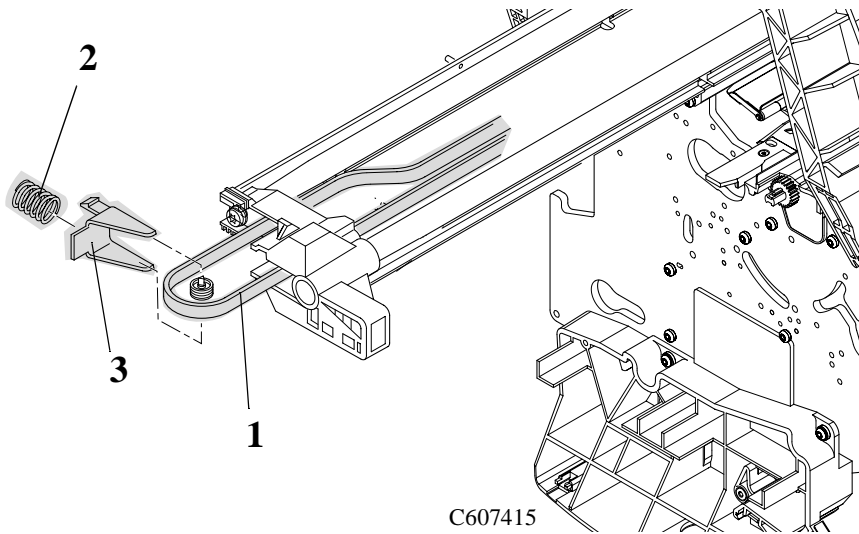

Figure 44: Carriage Assembly and Belt

10. Remove the belt (item 1) from the belt motor pulley (item 2) on the right hand side of the Printer (refer to Figure 45)

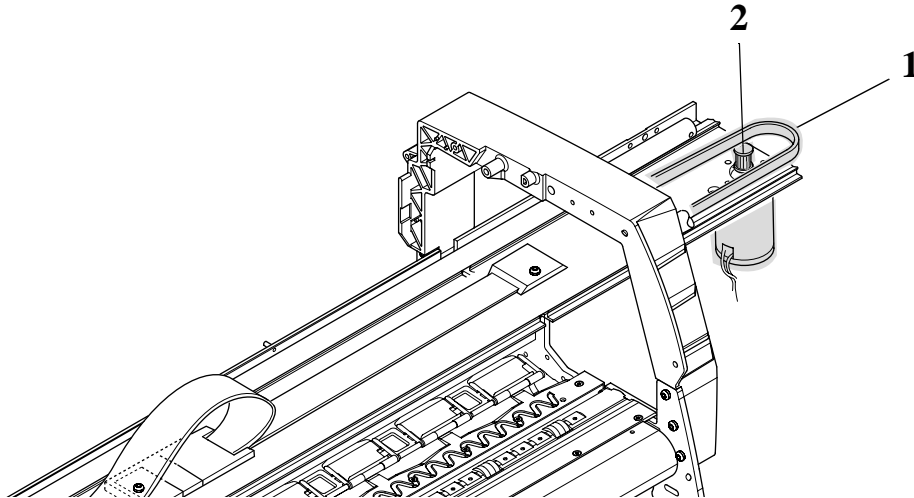

Figure 45: Carriage Assembly and Belt

NOTE

For steps 11 and 12, refer to Figure 46.

11. Remove the 5.5mm nut (item 1) from the left side of the Printer that attaches the Encoder Strip (item 3) to Spring Clip (item 2).

NOTE

To perform the next step use a screw driver to press the spring clip (item 2) in towards the middle of the printer.

12. Release the Encoder Strip (item 3) from the retaining pin (item 4) on the Spring Clip (item 2).

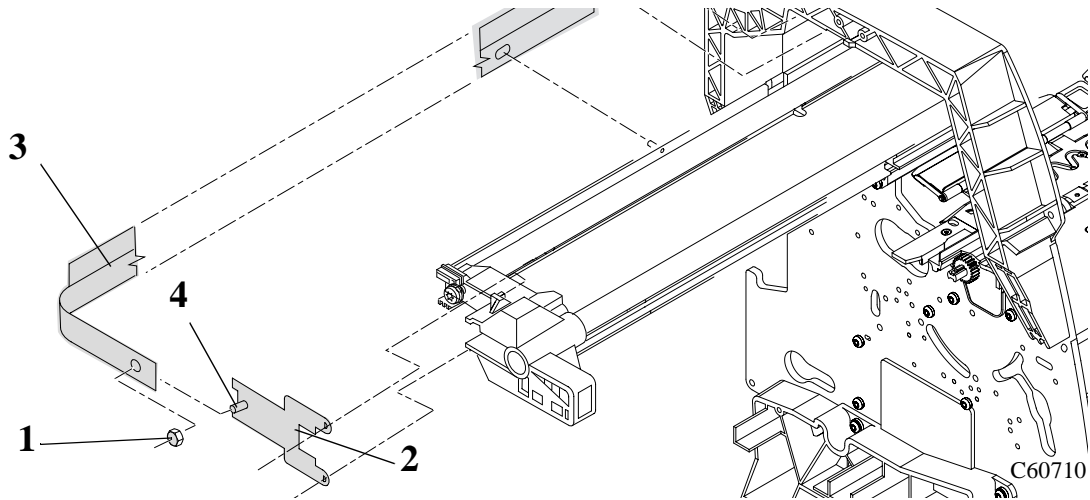

Figure 46: Encoder Strip

NOTE

For steps 13 to 15, refer to Figure 47.

13. Remove the tensioner pulley (item 1) from the belt (item 2) which is located in the tensioner assembly (item 3).
14. Remove the two T-15 screws (item 4) securing the tensioner assembly to the slider rods (item 5).
15. Remove the tensioner assembly (item 3).

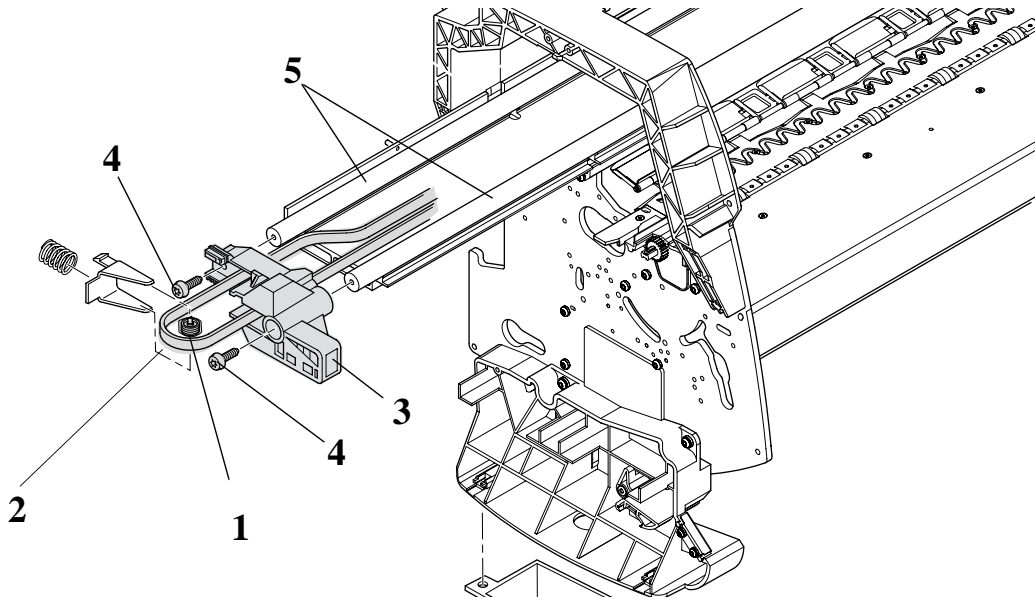

Figure 47: Carriage Assembly and Belt

NOTE

For the following steps, refer to Figure 48.

CAUTION

The rear bushing (item 1) on the carriage assembly is tensioned with a spring (item 2). When removing the carriage assembly (item 3) hold the rear bushing on the carriage assembly.

16. Remove the carriage assembly (item 3) by sliding it off the slider rods.
17. Remove the belt (item 4) from the carriage assembly by releasing it from retaining clips (item 5) underneath the carriage assembly.

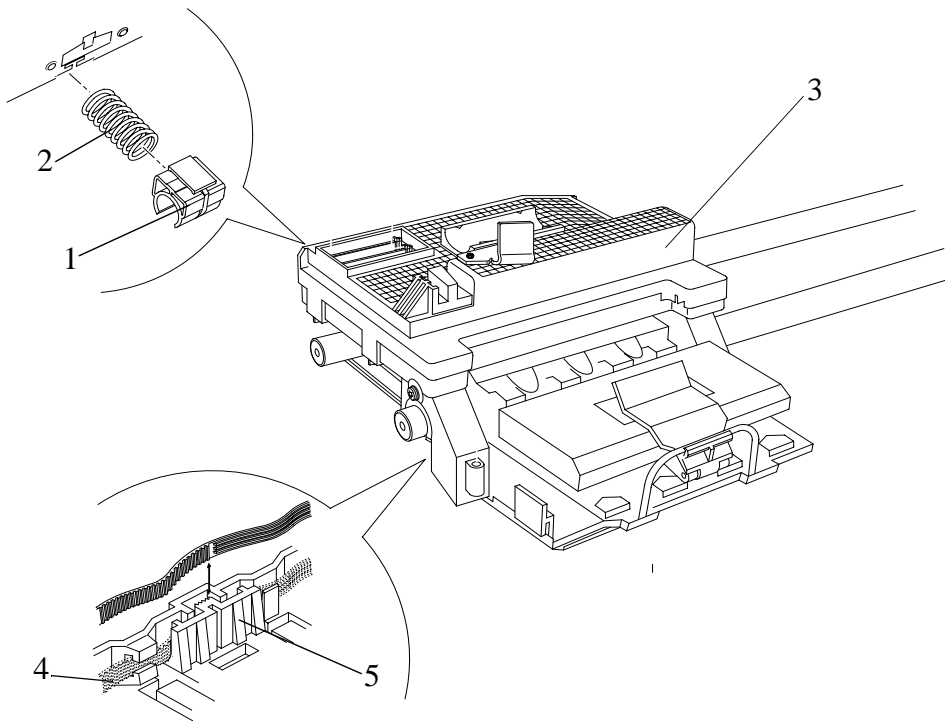

Figure 48: Carriage Assembly and Belt

Installation of the Carriage Assembly

NOTE

Please take note of the following steps when installing the Carriage Assembly.

1. Make sure that the trailing cable is seated correctly and that the trailing cable support is straight and has NO bubbles as shown in Figure 49.

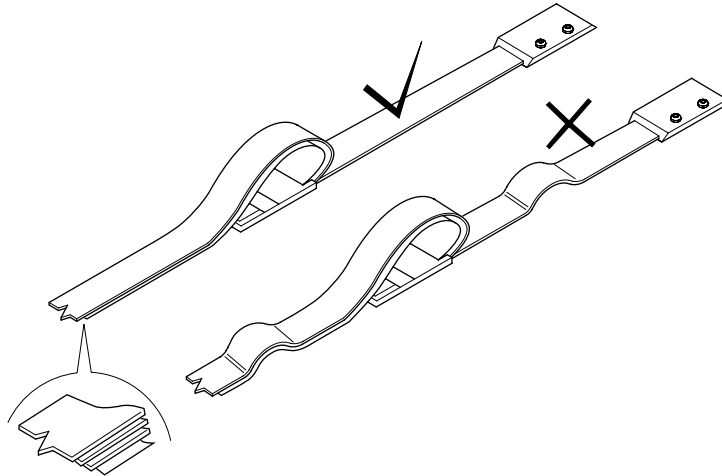

C607441

Figure 49: Trailing Cable Installation

2. When installing the Carriage, engage the Clutch Arm as shown in Figure 50.

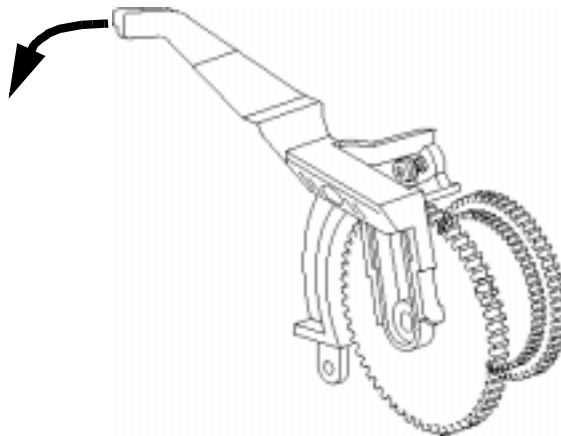

C607420d

Figure 50: Clutch Assembly

3. When installing the belt, make sure it is not twisted and is installed in the correct orientation as shown in Figure 51.

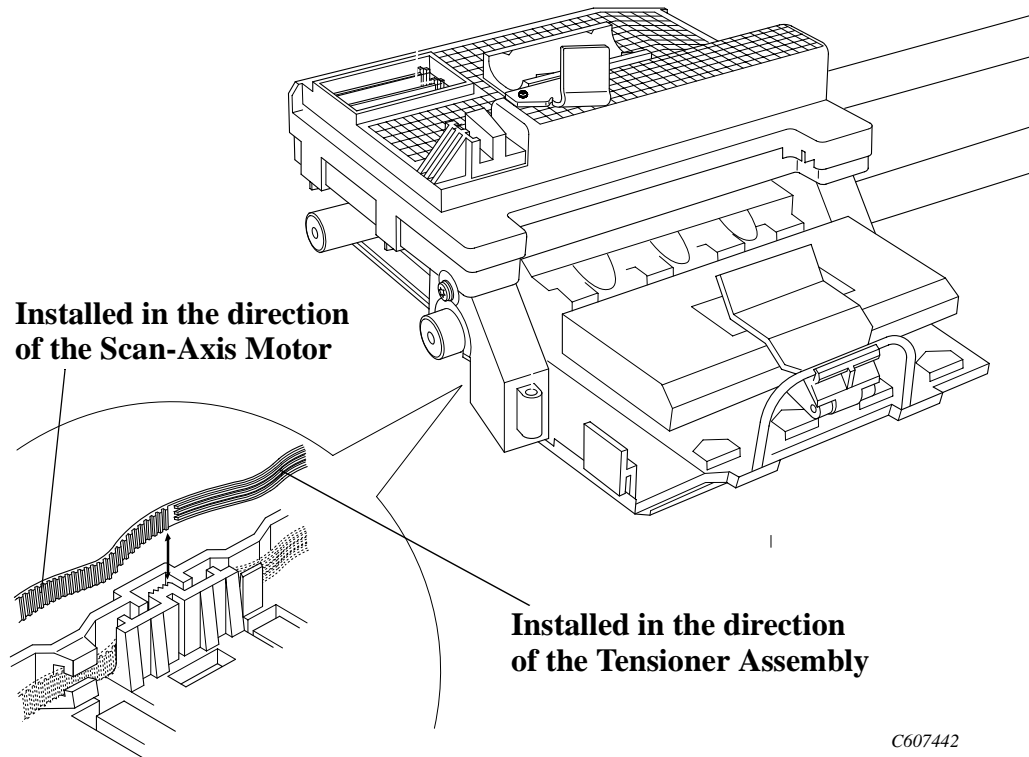

Figure 51: Belt Installation

NOTE

You must perform the following Service Calibrations after the installation of the Carriage Assembly.

- Carriage Height Calibration ⇒ Page 5-24.
- Line Sensor ⇒ Page 5-9.
- Service Station ⇒ Page 5-11.
- Roller Mark Position ⇒ Page 5-13.
- Color to Color Calibration ⇒ Page 5-16.
- Pen Alignment ⇒ Page 5-22.

Tubes System Assembly

Refer to Figure 52 to Figure 63.

Removal

1. Remove the Printheads, Ink Cartridges and the Printhead cleaners.
(Refer to the User's Guide for details)

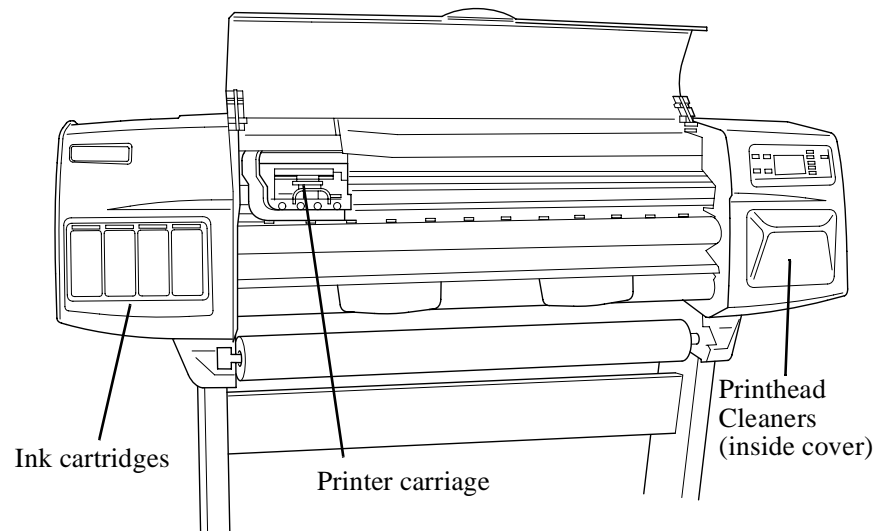

Figure 52: Printer Carriage Location

WARNING

Now turn off the printer with the main power switch at the rear of the printer.

2. Move the carriage to a position where you can access the printhead tube connector (Refer to Figure 53).

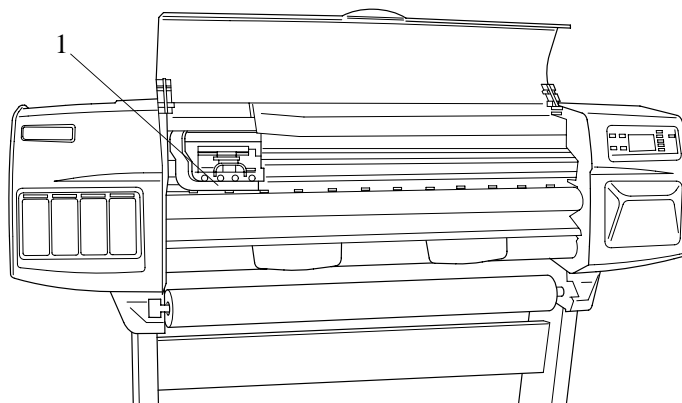

Figure 53: Printhead Tube Connector

3. Remove the following:
 1. "Window" see page 8-30.
 2. "Top Cover" see page 8-31.

NOTE

For the following steps, refer to Figure 54.

4. Loosen the retaining screw T-9 at the back of the printhead tube connector.
5. Remove the printhead tube connector.

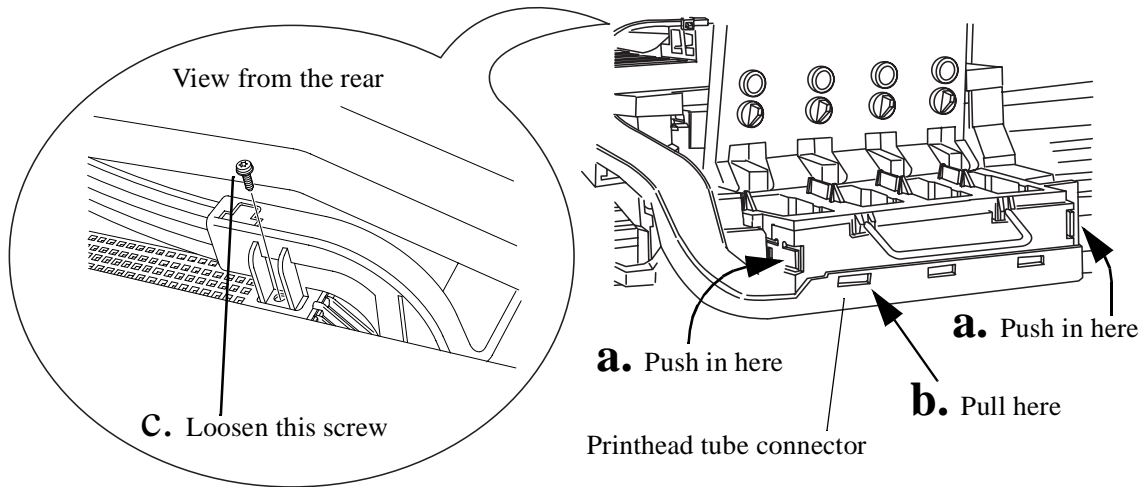

Figure 54: Printhead Tube Connector Removal

6. Remove the tube retaining clip (item 1) from the back of the printer (refer to Figure 55).

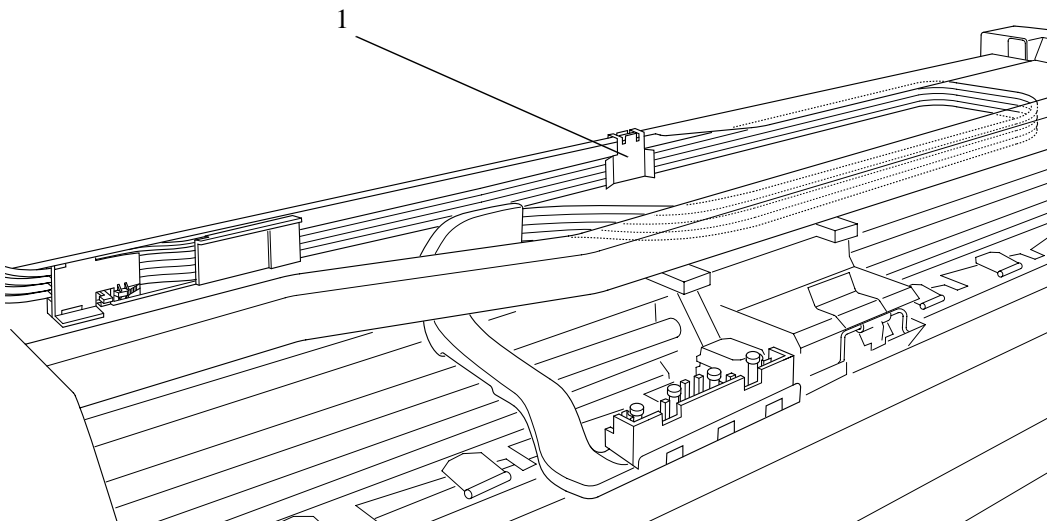
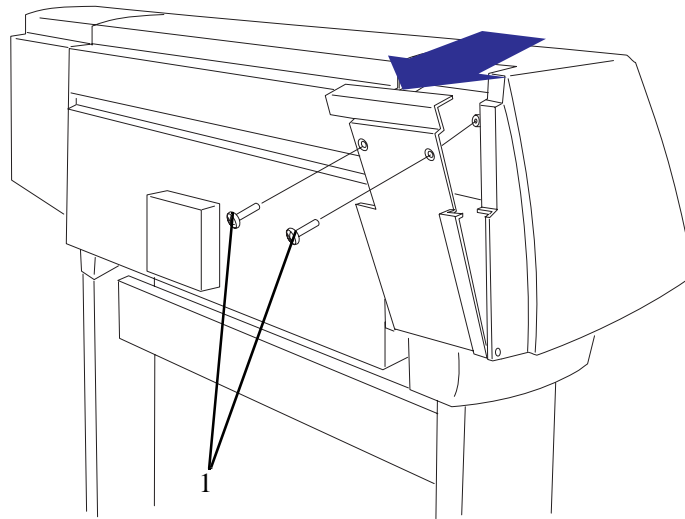

Figure 55: Tube Retaining Clip

NOTE**Working from the rear of the printer.**

7. Open the door at the back of the left hand cover by removing two T15 screws (item 1) (refer to Figure 56).

**Figure 56: Rear Left Hand Cover**

8. Release the tube holder (item 1) from the rear of the left hand cover by pushing it up and out (refer to Figure 57).

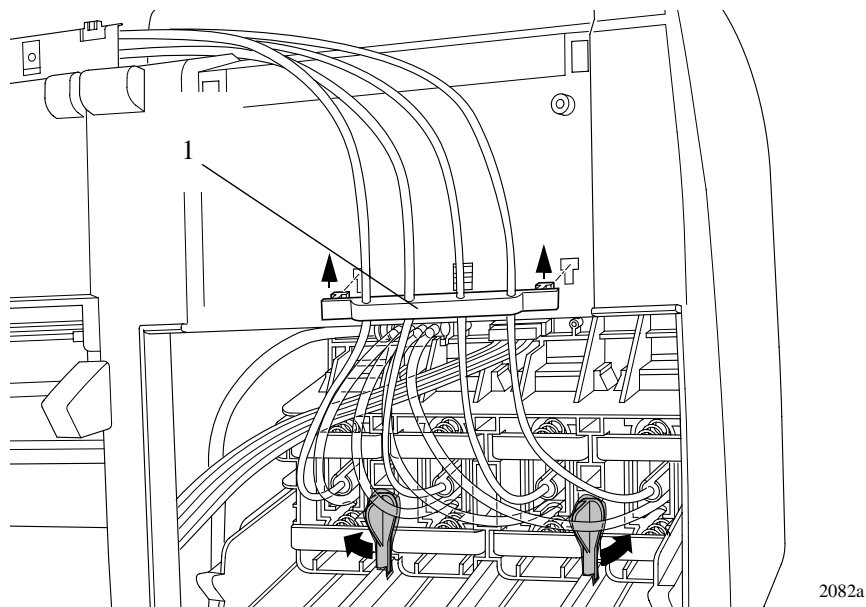
**Figure 57: Rear Tube Grip**

9. Twist the two latches (item 1) at the rear of the ink cartridge tube connector (item 2) to the outwards. This will release the complete assembly (refer to Figure 58).

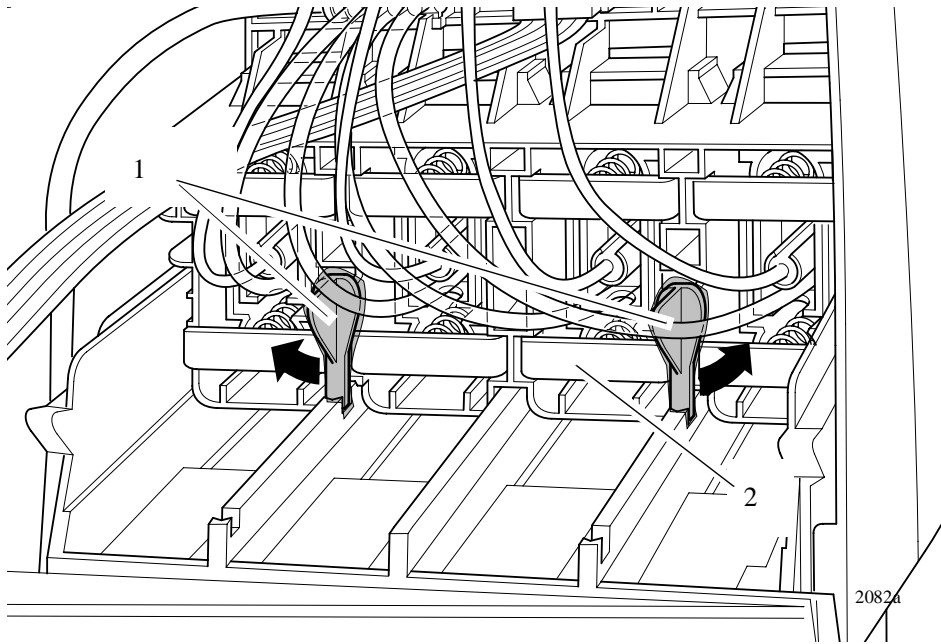

Figure 58: Latches

10. Slide the ink cartridge tube connector assembly (item 1) towards you (refer to Figure 59).

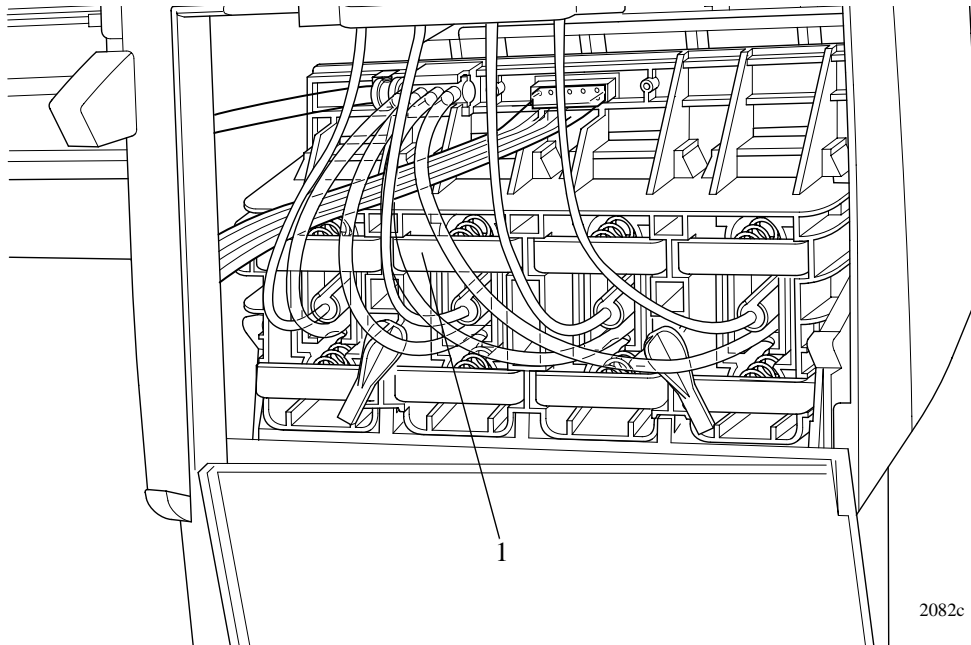

Figure 59: Ink Cartridge Tube Connector (pulled back)

11. Disconnect the ink cartridge tube connector cable (item 1) (refer to Figure 60).

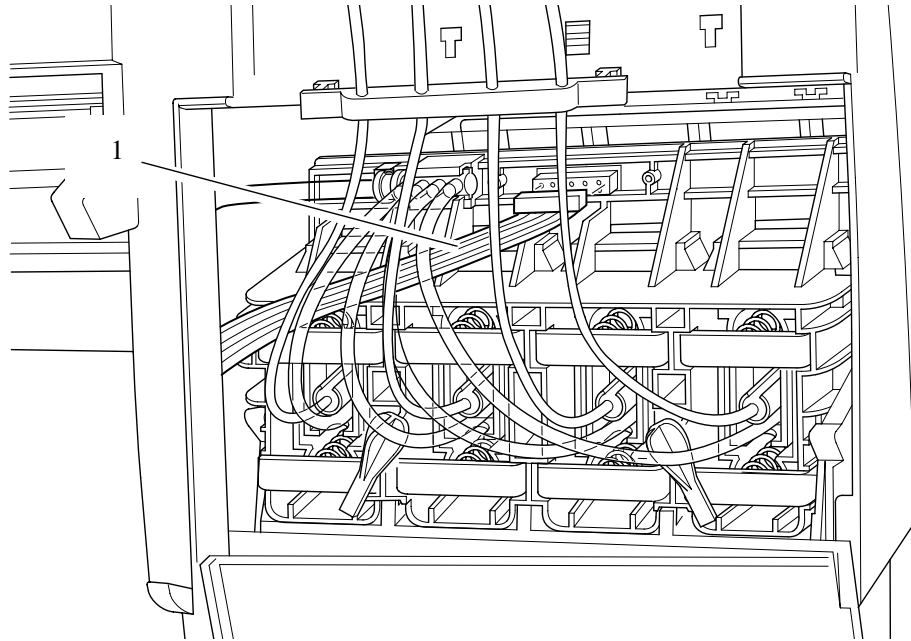

Figure 60: Ink Cartridge Tube Connector Cable

12. Disconnect the air tube (refer to Figure 61).

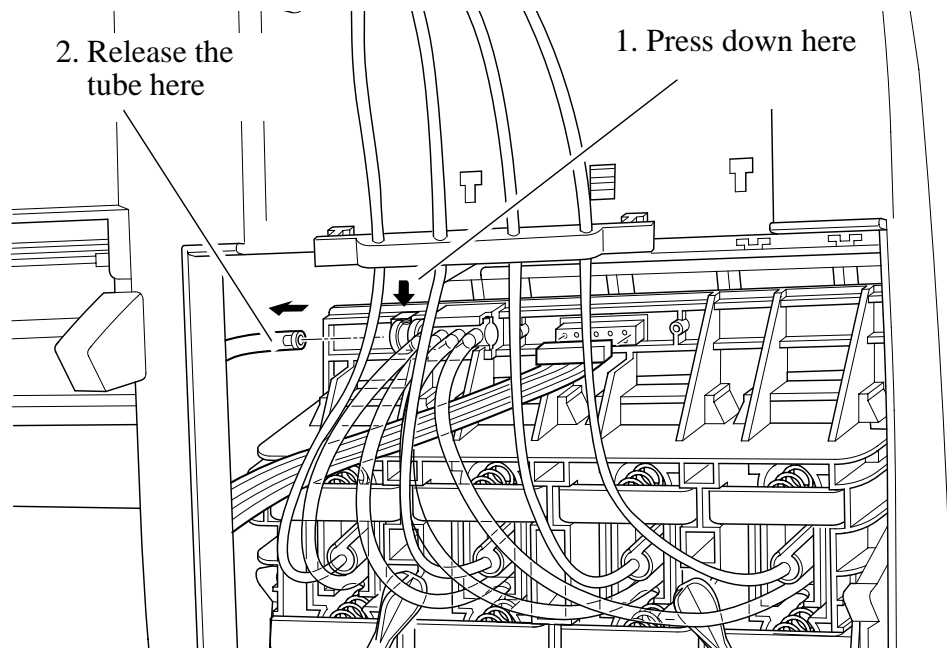

Figure 61: Air Tube

13. Remove the ink cartridge tube connector (item 1) from the rear of the left hand cover (item 2), rest the assembly on the left hand cover (refer to Figure 62).

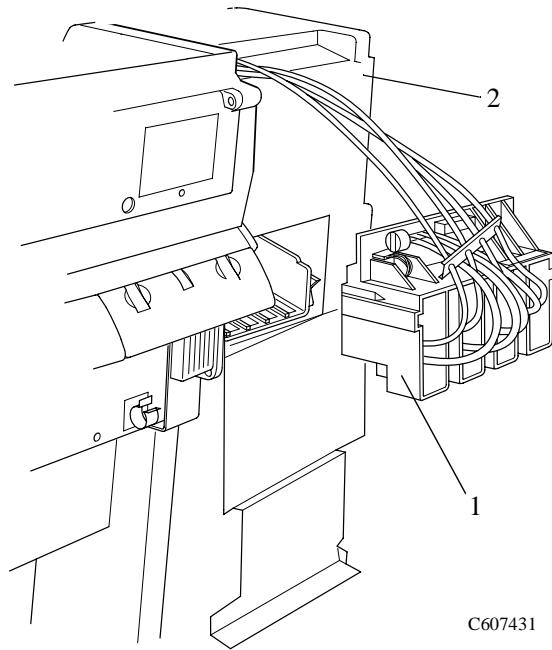

Figure 62: Ink Cartridge Tube Connector (pulled out)

14. Push the tab (item 1) towards you and then push the complete tube retaining clip (item 2) to the right and then pull towards you (refer to Figure 63)

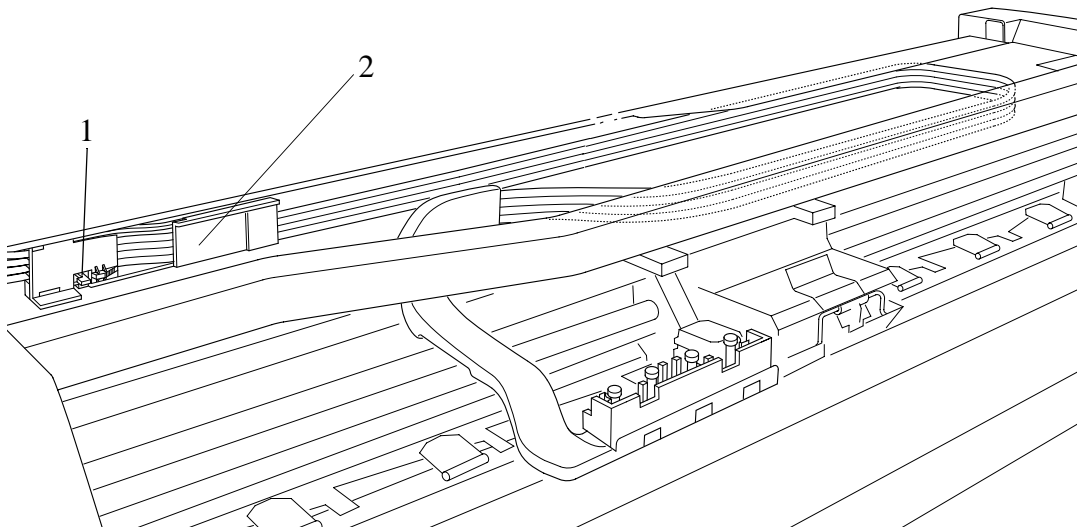

Figure 63: Tube Retaining Clip

CAUTION

The complete ink tube system is full of ink.

15. Now you can remove the complete Tubes System from the printer by sliding the tubes from between the tube guides.

Restarting the printer

- 1 Turn the printer ON from the main power switch at the rear of the printer and from the power switch on the front panel.
2. The front panel displays:



System Startup
Press Enter to Continue

C4704034

3. Press the **Enter** button.
4. Lift up the window and install four setup printheads into the Printhead carriage. (Refer to the User's Guide for details).
5. Install the Ink Cartridges. (Refer to the User's Guide for details).
6. The front panel displays:



Initializing printer
Wait

C4704034

7. Wait for about 30 seconds.
8. Remove the setup printheads from the printer carriage.
9. Install the Printheads and the Printhead Cleaners (Refer to the User's Guide for details).

NOTE

You must perform the following Service Calibrations after the installation of the Tubes System.

- Calibrations Backup ⇒ Page 5-19.
- Pen Alignment ⇒ Page 5-22.

Ink Leak Detector Assembly

Refer to Figure 64 to Figure 66.

Removal

WARNING

Switch off the printer and remove the power cord.

1. Remove the following:
 1. "Window" see page 8-30.
 2. "Top Cover" see page 8-31.
 3. "Back Cover" See Page 8-32.
 4. "Right Rear Cover" See Page 8-24.

NOTE

Working from the rear of the printer.

2. Open the door at the back of the left hand cover by removing two T15 screws (item 1) (refer to Figure 64).

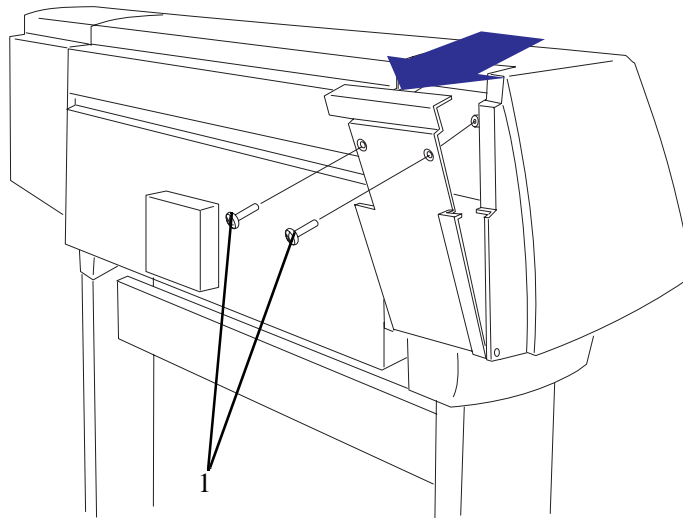

Figure 64: Rear Left Hand Cover

3. Disconnect the Leak Detector Cable from position **P4 INK LEAK DETECTOR** on the Electronics Module.
4. Locate the clip that attaches the Leak Detector Cable to the side plate. Remove the screw that attaches the clip to the side plate.

5. Remove the screw and clip (item 2) from the back of the Printer and disconnect the Ink Leak Detector Cable Connector (item 1) as shown in Figure 65. The Ink Leak Detector Cable can now be removed completely

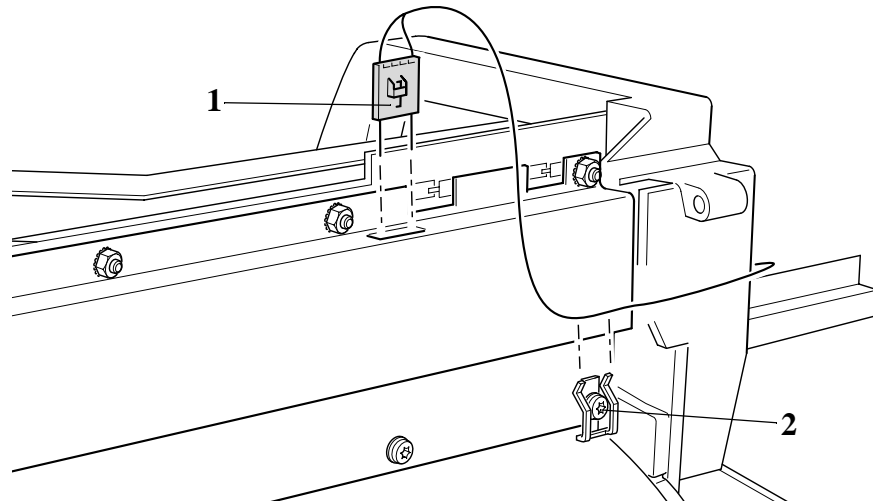

Figure 65: Leak Detector Cable

6. Unclip the Leak Detector from the Printer and remove as shown in Figure 66.

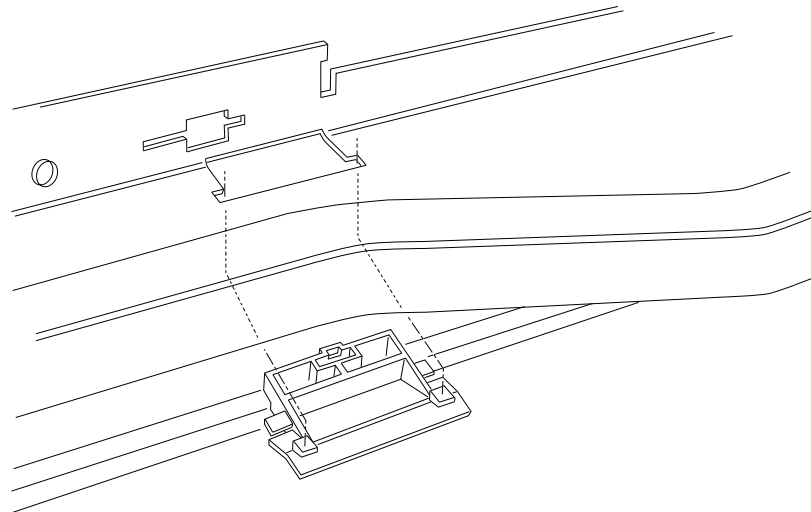

Figure 66: Leak Detector

Front Platen Assembly

Refer to Figure 67.

Removal

WARNING Switch off the printer and remove the power cord.

1. Open the window.

NOTE In the following steps, please treat the screws with great care as they can easily be damaged.

2. Remove the nine T-10 screws (item 1) from the front platen assembly (item 2) and remove the front platen.

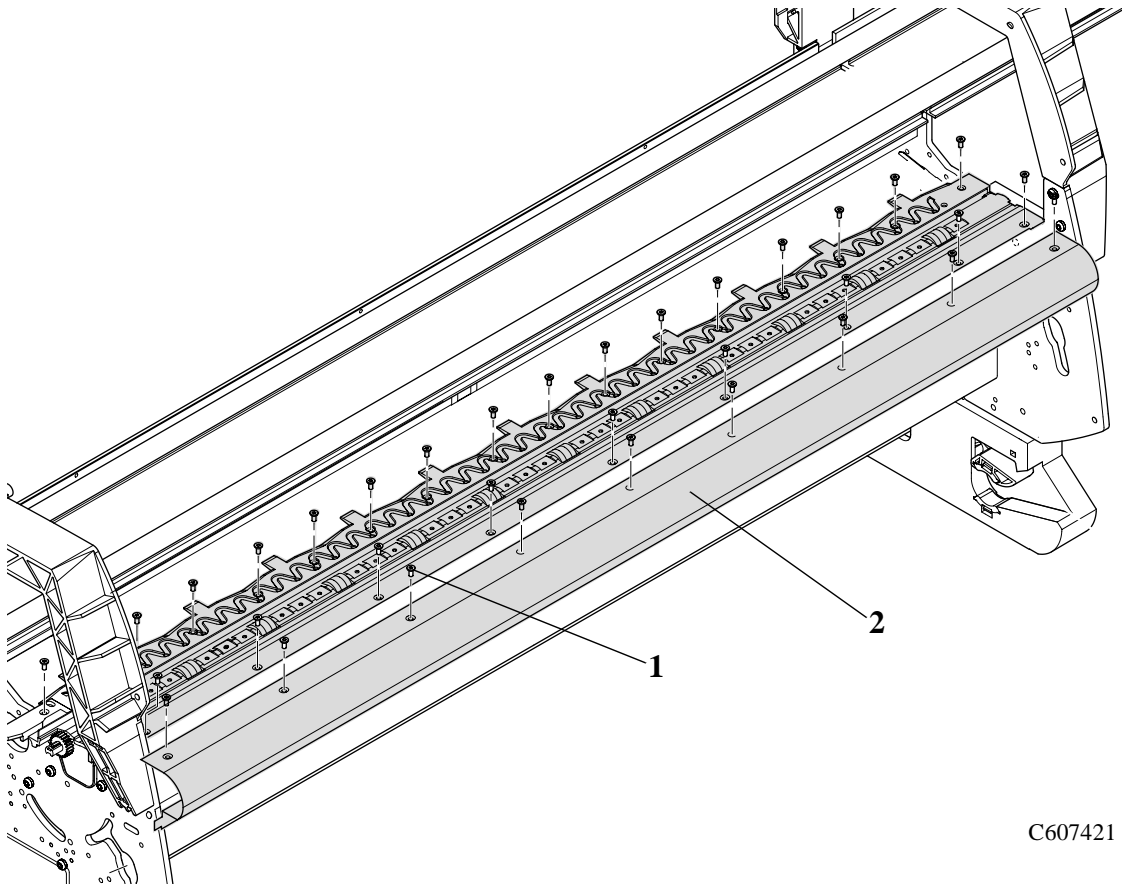

C607421

Figure 67: Front Platen Assembly

Platen Assembly

Removal

WARNING

Switch off the printer and remove the power cord.

1. Open the window.

NOTE

In the following steps, please treat the screws with great care as they can easily be damaged.

2. Remove twenty-nine screws T-10 screws (item 1) from the platen assembly (item 2) and remove the platen assembly (see Figure 68).

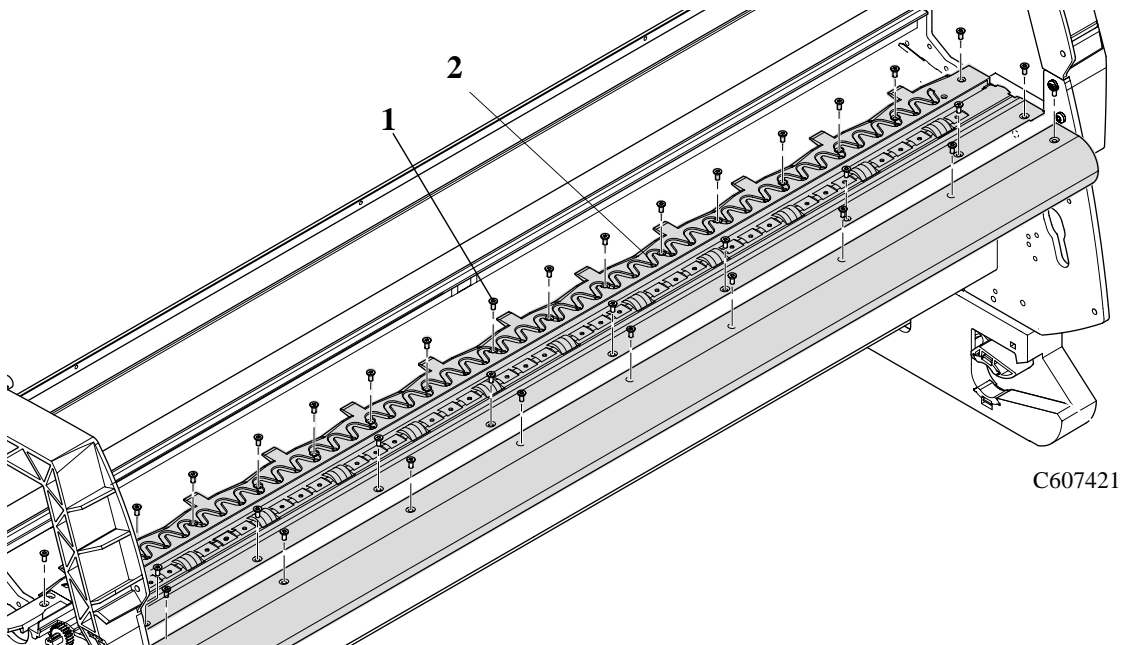

Figure 68: Platen Assembly

Installation of the Platen Assembly

CAUTION

When installing the Platen Assembly, make sure the screws are installed properly so that the heads of the screws do not interfere with the media path when the printer is in use. Do not exceed a torque of 10 psi on the screws.

NOTE

You must perform the following Service Calibrations after the installation of the Platen Assembly.

- Carriage Height Calibration ⇒ Page 5-24.
- Service Station ⇒ Page 5-11.
- Color to Color Calibration ⇒ Page 5-16.

Paper Entry Assembly

Refer to Figure 69 to Figure 71.

Removal

WARNING

Switch off the printer and remove the power cord.

1. Remove the following:
 1. "Left Hand Cover" see page 8-13.
 2. "Left Hand Trim" see page 8-18.
 3. "Ink Supply System Assembly" see page 8-19.
 4. "Clutch Assembly and Miscellaneous Parts" see page 8-21.
2. Remove the T-15 screws (item 2) securing the entry roller (item 1) to the left hand chassis (refer to Figure 69). Pull out the left side of the entry roller first and then remove completely.

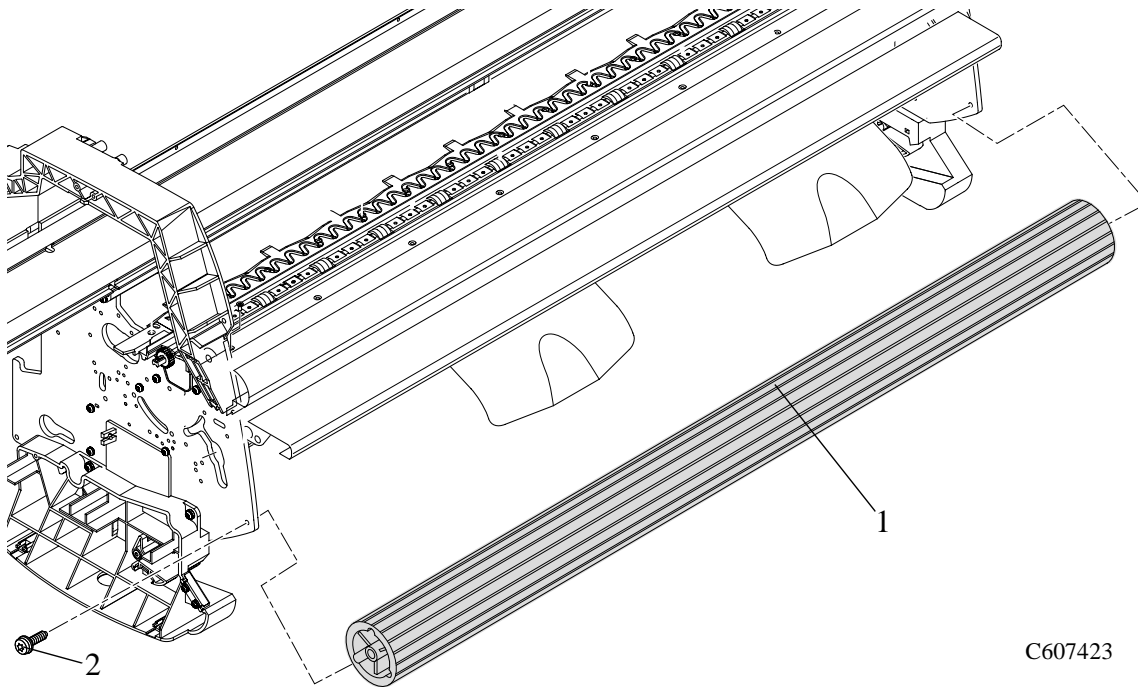
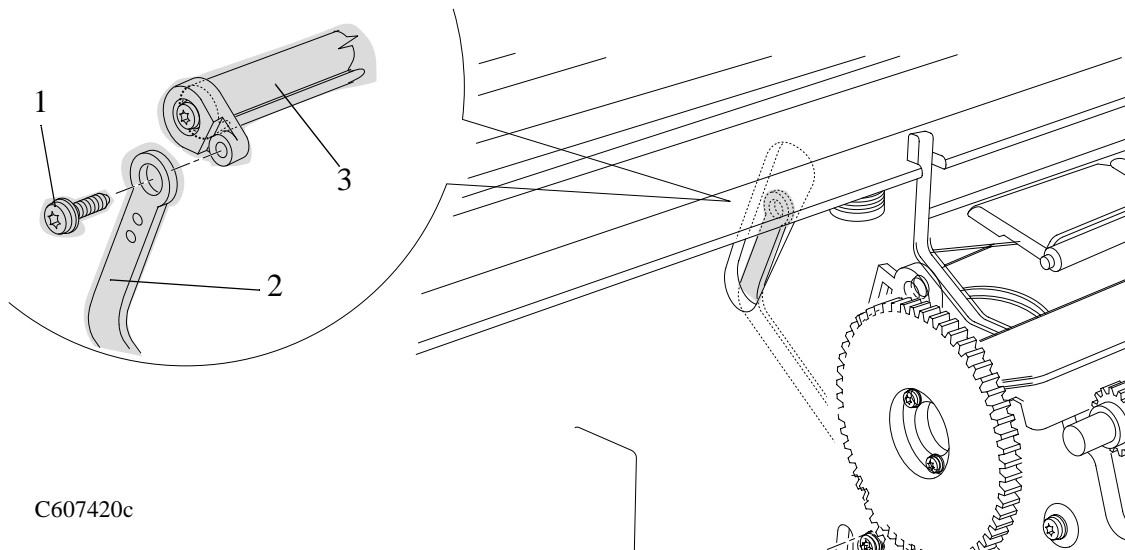

Figure 69: Entry Roller

3. Remove the T-10 screw (item 1) from the linkage rod (item 2) and the pinch-wheel cam (item 3) (refer to Figure 70).



C607420c

Figure 70: Linkage Rod

NOTE

For steps 4 and 5, refer to Figure 71.

4. Release the right side of the paper entry assembly (item 1) from a retaining hole in the right hand side chassis.
5. Remove the right side of the paper entry assembly (item 1) first and then the left side.

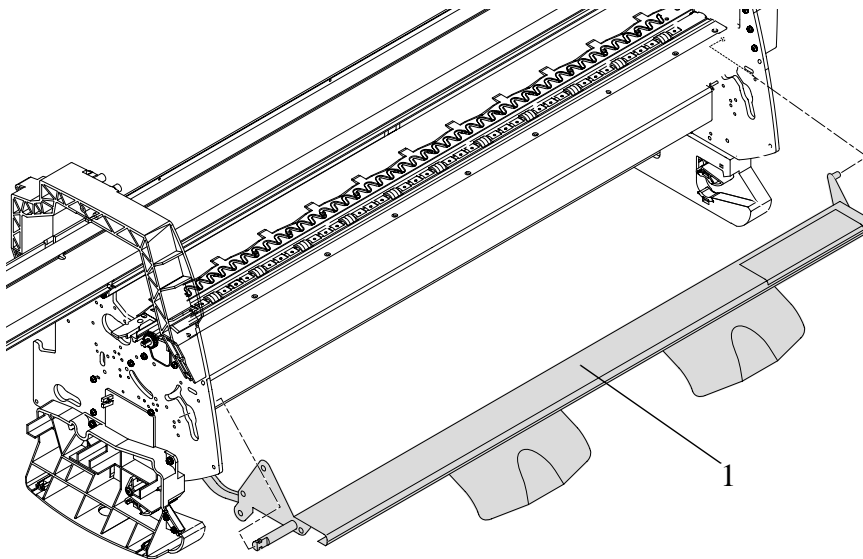

C607424

Figure 71: Paper Entry Assembly

Roller Guide

Refer to Figure 72 to Figure 75.

Removal

WARNING

Switch off the printer and remove the power cord.

1. Remove the following:
 1. "Left Hand Cover" see page 8-13.
 2. "Right Hand Cover" see page 8-4.
 3. "Electronics Module" see page 8-25.
 4. "Ink Supply System Assembly" see page 8-19.
 5. "Service Station Assembly" see page 8-8.
 6. "Paper-axis Motor Assembly" see page 8-12.

NOTE

Working from the rear of the printer.

2. Remove the two T-15 screws (item 1) securing the left hand rear platen mount (item 2) (refer to Figure 72)
3. Remove the two T-15 screws (item 3) securing the right hand rear platen mount (item 4) (refer to Figure 72).

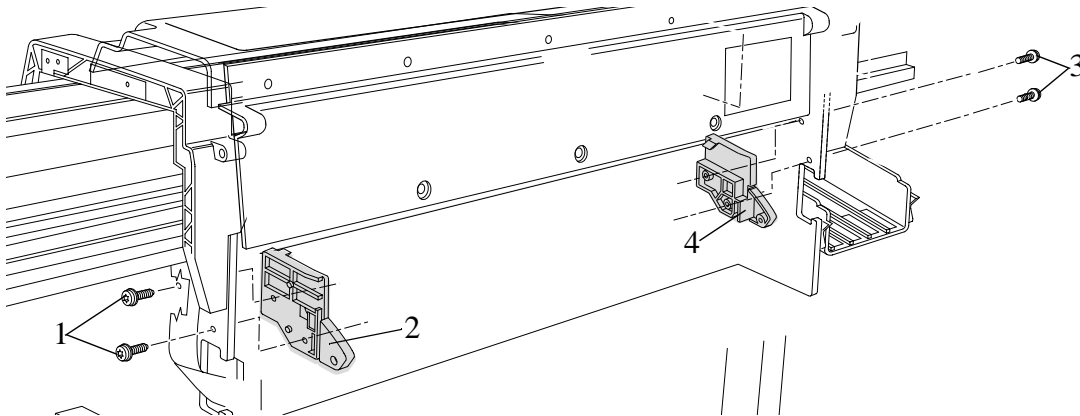

Figure 72: Platen Mounts

4. Remove the four T-15 screws (item 1) securing the left hand electronic module mount (item 2) to the left hand side chassis (refer to Figure 73).

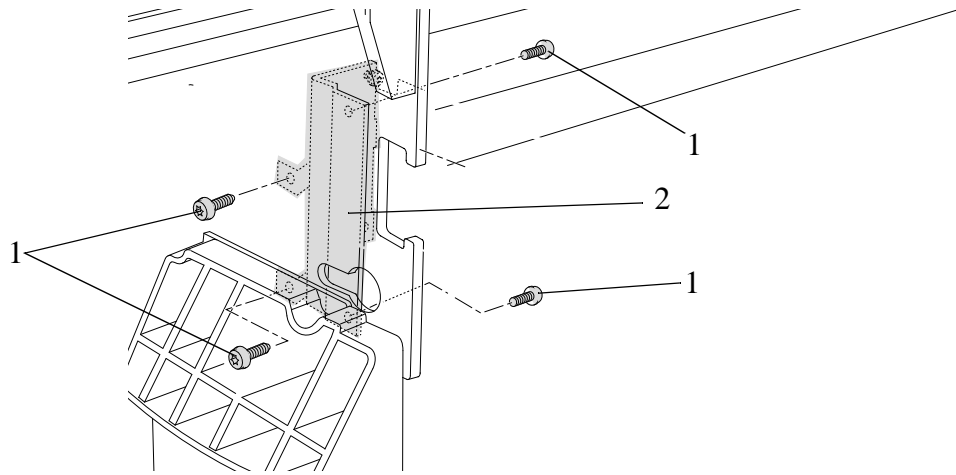

Figure 73: Left Electronic Module Mount

5. Remove the four T-15 screws (item 1) securing the right hand electronic module mount (item 2) to the right hand side chassis (refer to Figure 74).

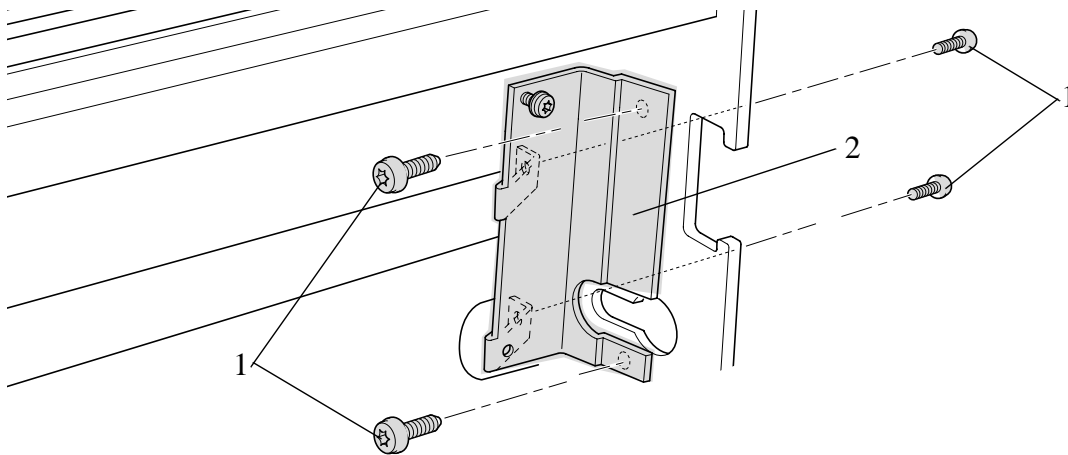

Figure 74: Right Electronic Module Mount

NOTE

For the following steps refer to Figure 75.

6. Remove the three T-15 screws from the right side of the roller guide assembly (item 2).

NOTE

Be careful not to drop the roller guide once the securing fasteners have been removed.

7. Remove the three T-15 screws (item 1) from the left side of the roller guide assembly and remove.

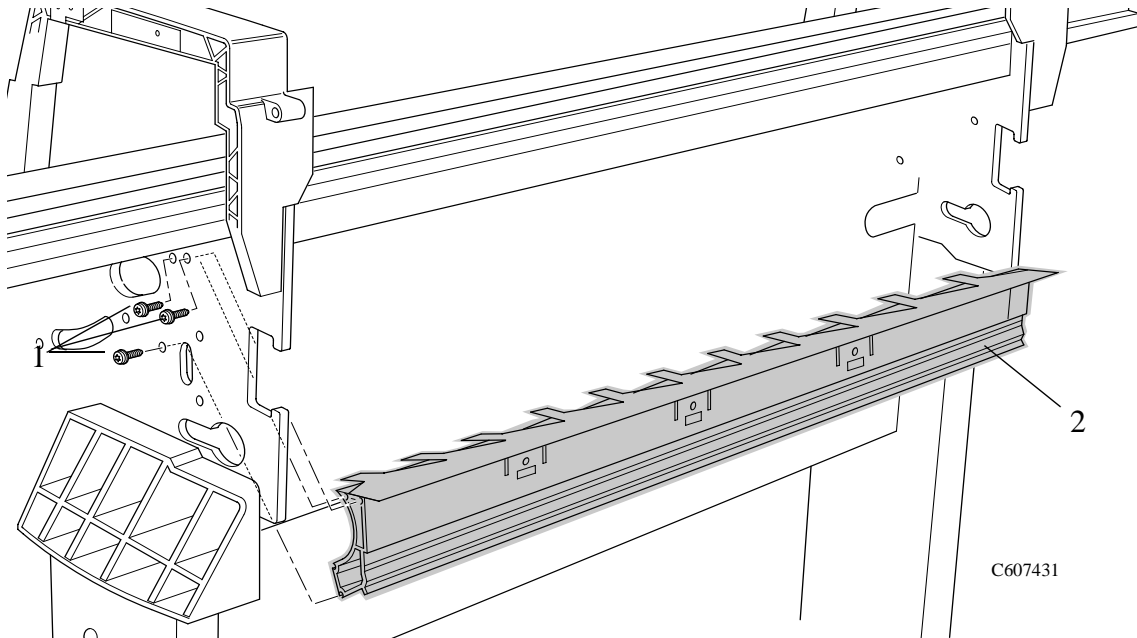

Figure 75: Roller Guide

Media Holder Strip

Refer to Figure 76.

Removal

WARNING Switch off the printer and remove the power cord.

1. Remove the following:
 1. "Electronics Module" see page 8-25.

NOTE Working from the rear of the printer.

2. Remove the three T-15 screws (item 1) securing the Media Holder Strip (item 2) to the Roller Guide (refer to Figure 76)

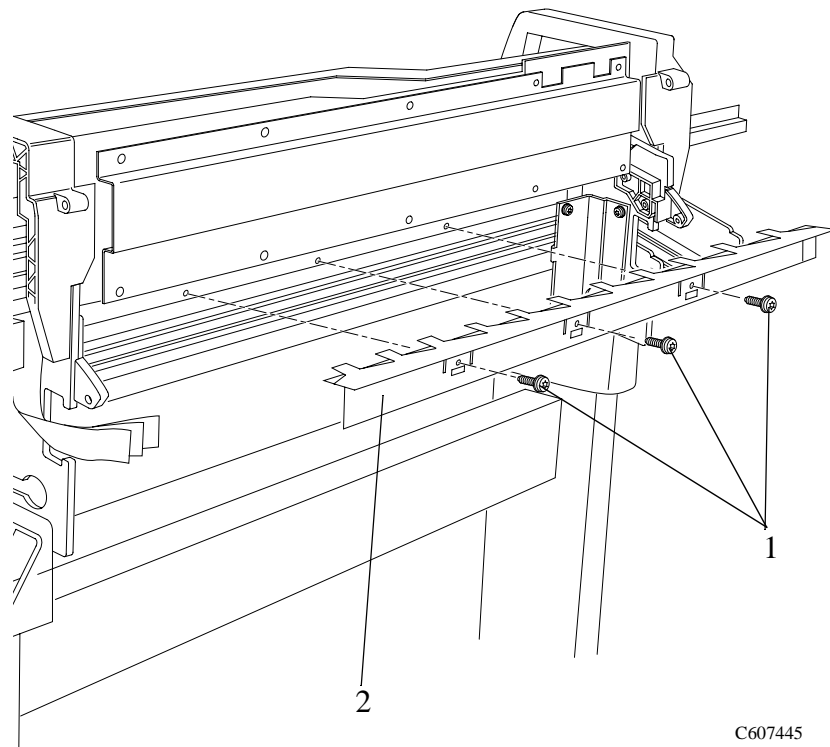

Figure 76: Media Holder Strip

Drive Roller

Refer to the Figure 77.

Removal

WARNING

Switch off the printer and remove the power cord.

1. Remove the following:
 1. "Clutch Assembly" see page 8-21.
 2. "Roller Guide" see page 8-66.

NOTE

Working from the rear of the printer.

2. Remove the roller (item 1) as follows:
 - a Pull the left side of the roller towards you and then pull the right side of the roller towards you
 - b Move the complete roller to the left.
 - c Remove the right side of the roller first and then the left side.

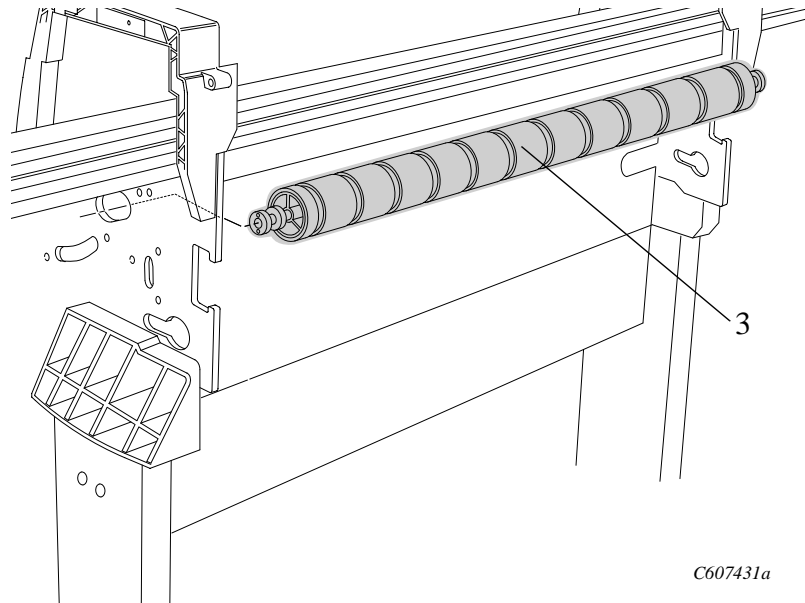

Figure 77: Drive Roller

NOTE

You must perform the following Service Calibrations after the installation of the Drive Roller.

- Accuracy Calibration ⇒ Page 5-6.
- Color to Color Calibration ⇒ Page 5-16.

Center Guide

Refer to Figure 78 to Figure 80.

Removal

WARNING Switch off the printer and remove the power cord.

1. Remove the following:
 1. "Left Hand Cover" see page 8-13.
 2. "Right Hand Cover" see page 8-4.
 3. "Electronics module" see page 8-25.
 4. "Ink Supply System Assembly" see page 8-19.
 5. "Clutch assembly" see page 8-21.
 6. "Service Station" see page 8-8.
 7. "Vacuum Fan" see page 8-11.
2. Lift up the paper entry assembly.
3. Remove the two T-15 screws from the left hand side plate securing the left side of the center guide (refer to Figure 78).

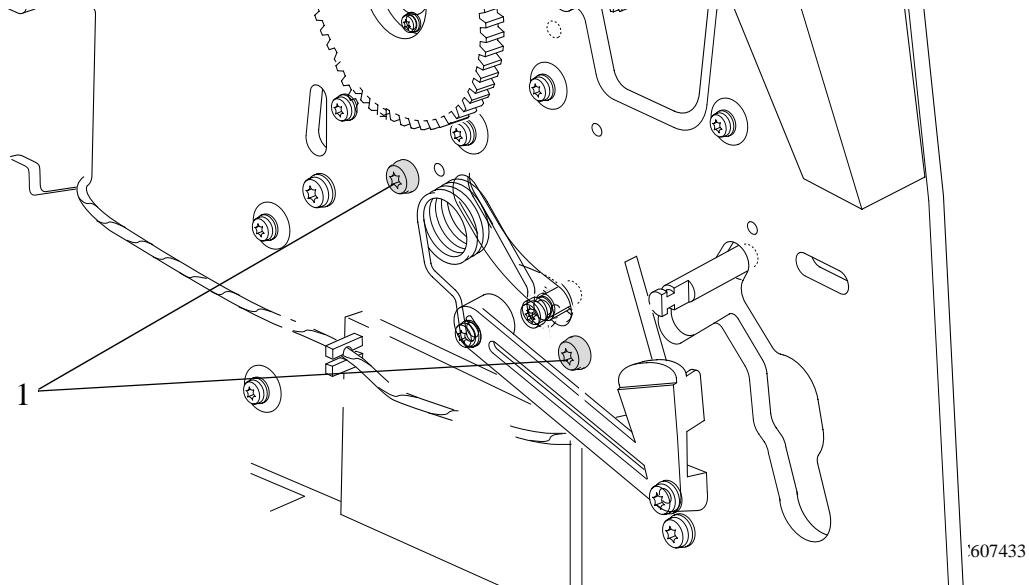
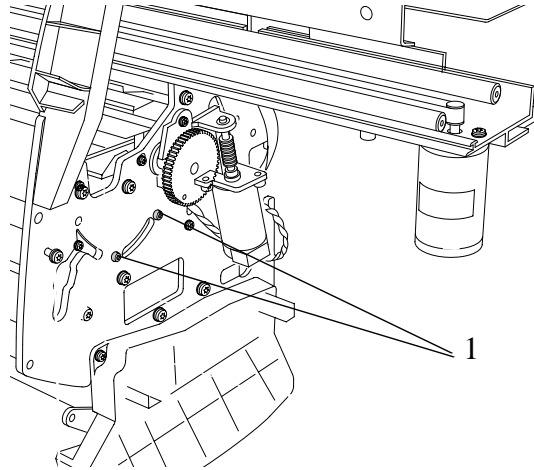

Figure 78: Left Hand Center Guide Screws

4. Remove the two T-15 screws from the right hand side plate securing the right side of the center guide (refer to Figure 79).



C607432

Figure 79: Right Hand Center Guide Screws

NOTE For re-installation purposes, note the position of the pins supporting the center guide in place.

NOTE Working from the front of the printer

5. Remove the center guide (item 1) (refer to Figure 80):
 - a Lift up the front of the center guide
 - b Pull the complete assembly towards you and remove.

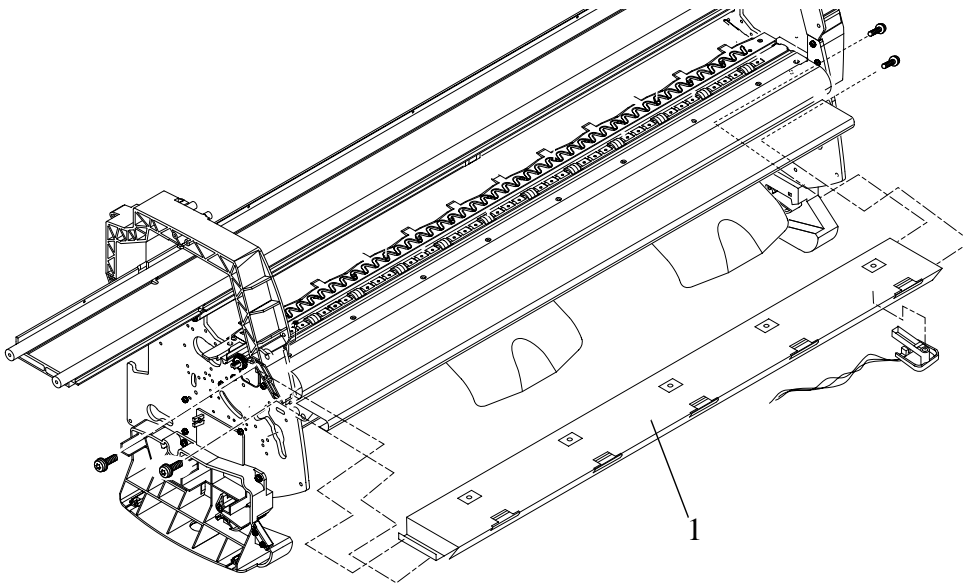

Figure 80: Center Guide

Pinch-Wheel Assembly and Cam

Refer to Figure 81 and Figure 82.

Removal

WARNING Switch off the printer and remove the power cord.

1. Remove the following:
 1. "Left Hand Cover" see page 8-13.
 2. "Right Hand Cover" see page 8-4.
 3. "Electronics Module" see page 8-25.
 4. "Ink Supply System Assembly" see page 8-19.
 5. "Clutch assembly" see page 8-21.
 6. "Roller Guide" see page 8-66.
2. Remove the T-10 screw (item 1) which secures the linkage rod (item 2) to the pinch-wheel cam (item 3)(refer to Figure 81).

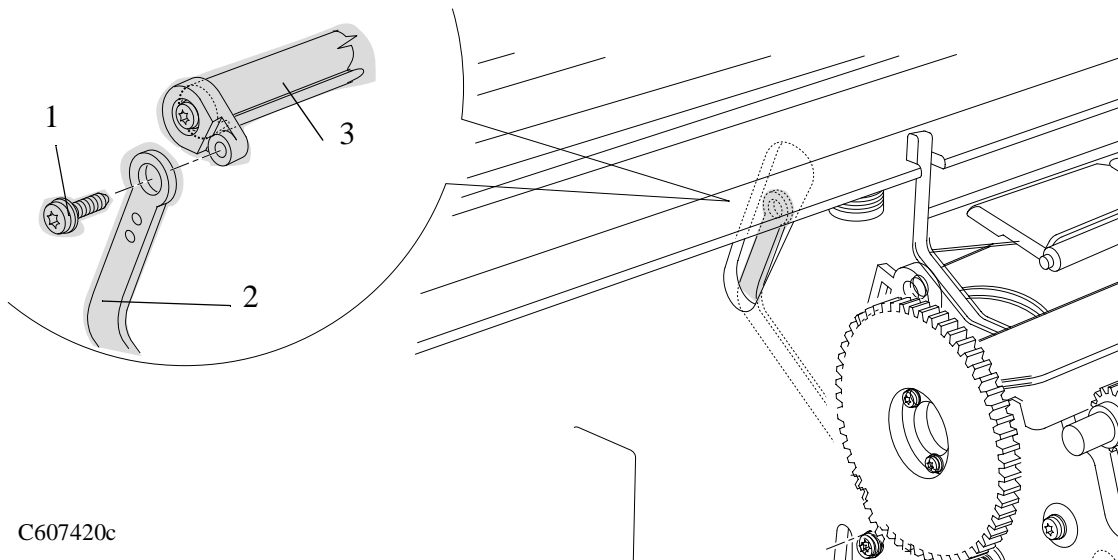

Figure 81: Pinch Wheel Cam

NOTE Working from the rear of the printer

NOTE For steps 3 and 4 refer to Figure 82.

3. Remove the twelve T-15 screws (item 1) securing the pinch-arm assemblies (item 2) to the underneath of the scan axis.

NOTE The screws also secure the pinch-wheel cam to the printer. Support the cam as the last of these screws are removed.

4. Remove the cam (item 3) from underneath the scan axis.

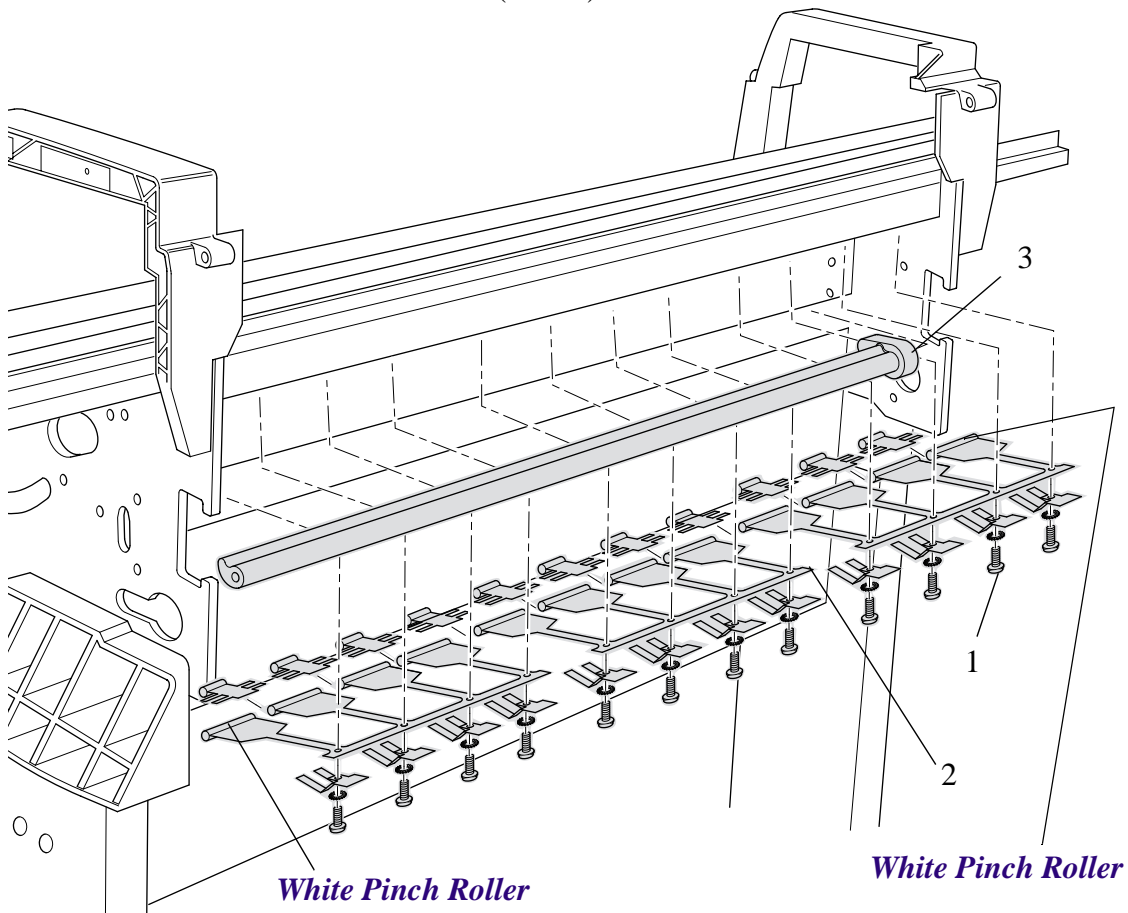

Figure 82: Pinch-arm Assemblies and Cam

NOTE During installation, make sure you install the Pinch Assembly with the White Pinch Rollers at each end.

Preventive Maintenance

9

Moisture on the Printer 9-2
Noisy Carriage Bushing 9-2
Belt Swelling 9-2
Cleaning the Printer 9-2
General Cleaning 9-2
Cleaning the Overdrive 9-3
Scheduled Maintenance 9-3
Level of Printer Usage 9-3
Scan-axis Maintenance 9-4

Preventive Maintenance

Moisture on the Printer

Users should use the Printer in an environment between 20% and 80% relative humidity. To recover from moisture condensation, turn the Printer Off, and, using the main roller as a reference, wait until the Printer is completely dry before using it again.

Noisy Carriage Bushing

To prevent noisy movement of the carriage, remove aluminum or dust particles from the bushing at the back of the carriage, and from the slider path along which the bushing moves.

Belt Swelling

To prevent new belts from swelling incorrectly, keep them in their bags with dessicant until you need to install them.

Cleaning the Printer

To maintain the Printer in good operating condition, keep it free of dust accumulation, ink, and other contamination. Cleaning intervals are determined by the Printer environment and by the types of Printer supplies used.

General Cleaning

Proper general cleaning should include the following:

- 1 Blow away dust accumulation with compressed air if available.
- 2 Clean the outer surface of the Printer with a damp sponge or cloth. Use a mild soap and water solution if necessary. Do not use abrasive cleaners.
- 3 Wipe the Printer dry with a soft lint-free cloth.

Cleaning the Overdrive

NOTE

If ink is spilled on the Overdrive, remove the ink. Due to the ink's reflectance, ink on the Overdrive can disrupt the Printer's edge-sensing function. To remove any ink from the Overdrive, perform the following procedure:

WARNING

Prevent water or other liquids from running onto electrical components or circuits, or through openings in the module.

- 1 Perform the Overdrive Cleaning Utility ⇒ Page 4-37.
- 2 Open the window and apply any common household cleaning solution (water based only) to a soft, lint-free rag and apply it to the Overdrive surface while it is rotating. Thoroughly clean the Overdrive surface. Also make sure that you clean the mark encoder on the left side of the driver roller.
- 3 Press **Enter** when you have completed the cleaning procedure.
- 4 Allow the Overdrive to dry before loading media in the Printer.

Scheduled Maintenance

In some segments of the printer market, the customer tends to print more than the maximum number of prints that the throughput allows, exceeding by far the limit of the design. When this happens the customer runs into print quality problems and continuous Printer failures.

The purpose of scheduled preventive maintenance is to avoid these failures - ensuring a good performance during all the product life.

Level of Printer Usage

Normal printer use means 7,000,000 Carriage Cycles. Under normal usage conditions, it will be approximately 5 years before the printer needs maintenance. If the printer is used more than the normal usage conditions, then it will need maintenance service much more frequently.

One of the EEROM counters is assigned to counting the number of carriage cycles. When the printer exceeds this amount, the front

panel displays the following message:

"Maintenance Advised"

The Service Configuration Print also conveys the usage information, and it is accessible by the user.

Once the maintenance advised message is displayed, the preventive maintenance kit must be used to replace the most worn parts of the printer. Use the Removal and Installation Chapter of this Service Manual as a guide to replace the necessary parts.

Preventive Maintenance Kit - Part Number C6072-60143

Scan-axis Maintenance

In addition to the wearing of the Scan-axis motor, the friction in this area can increase due to the accumulation of ink particles and dust from the media or the atmosphere in the vicinity of the slider rods.

Scan-axis maintenance requires the cleaning of the slider rods properly, and a lubricant to apply onto the rods.

NOTE

The most important parts to keep clean are the upper and internal sides of the rods.

Functional Overview

10

Introduction	10-2
HP DesignJet 1050C Printer	10-2
HP DesignJet 1055CM printer	10-2
Electrical System	10-2
Power Supply Unit (PSU)	10-3
Soft Power-Off Switch	10-4
Front Panel	10-4
Ink Delivery System (IDS)	10-5
Ink Supply Station (ISS)	10-5
Tubes System	10-6
Air Pressurization System (APS)	10-7
Ink Level Sense (ILS)	10-7
Leak Detect System (LDS)	10-8
Service Station	10-9
Print Head Cleaner (PHC)	10-9
Cap	10-10
Wiper	10-10
Spittoon	10-10
Snout Wiper	10-11
Handle and Printable Label	10-11
Printer Specifications	10-12
Printable Area	10-16
Interface Specifications	10-17
Regulatory Notices	10-18
Declaration of Conformity	10-22

Introduction

This Chapter contains a simplified description of the HP DesignJet 1050C/1055CM Printer circuits and mechanical functions. Mechanical and printed Circuit Assembly (PCA) overviews present a functional description of how the Printer operates.

HP DesignJet 1050C Printer

The HP DesignJet 1050C will have a network interface, 16 MB of memory but will NOT include the Hard Disk Drive.

HP DesignJet 1055CM printer

The HP DesignJet 1055CM will have a network interface, 32 MB of memory and a 2.1 Gbytes Hard Disk Drive. It will also be Postscript ready.

Electrical System

The electrical system of the Printer consists of six major blocks and their associated cabling:

- **Power Supply Unit:** Connected to the mains supply of whichever country this block provides 24V, 5V, 3.3V and -15V to the rest of the electrical system. It has a soft power switching feature allowing the firmware to control when power is removed from the system, and eliminates the need for high tension cables to the front panel.
- **Main Electronics:** This block contains the I/O, central processing units and controls most of the motors and sensors in the printer. The motors and sensors themselves are located throughout the printer and are connected to the main electronics via cables.
- **Carriage:** Connected to the printheads, this block supplies power to them, as well as monitoring and protecting them from damage. It also has the ability to control warming and to perform continuity checking, as well as controlling the line sensor. The carriage encoder is also located in this block.
- **Ink supply station:** The Ink Supply Station is connected to the Ink Cartridge supplies, and controls air pressure (pump, sensor and valve), as well as monitoring ink levels and the supply latch

sensor.

- Service station: Contains the electronics needed to perform drop detection, a DC motor/encoder for capping, wiping and spitting and a stepper motor for priming.
- Front Panel: is the user interface. It consists of an LCD display, a key panel and six LEDs.

Power Supply Unit (PSU)

The PSU is used to supply the power required by the product in any condition. The PSU provides +5 V, +3.3 V, -15 V and +24 V to the main board with the following maximum output currents:

Voltage	Maximum Output Current (A)	Systems
+3.3	12.0	Microprocessor, Memory and digital Logic
+5.0	3.0	Digital and Analog Logic
+24.0	13.5	Analog power systems and Carriage Voltage Supply
-15.0	0.1	Front Panel Auxiliary Voltage

The PSU is housed in the electronics enclosure and there are two connections with the main board: voltage supply connection and auxiliary output connection. The voltage supply connection is implemented via a 15 pin connector with 14 wires, this connector supply the +3.3V, +5 V and +24 V voltages and the ground lines to the electronics. The auxiliary output connector provides the -15V voltage, the PSU preset signal and the soft power off signal. PSU preset signal is a logic signal generated by the PSU, when the PSU is in on state this line is in open condition, when the unit is to switch off the signal is grounded at least 3 ms before the +3.3V and +5V outputs are out of regulation. The power off signal is a signal generated by the main electronics and is used to turn off the power supply. When the signal is not actuated the PSU is in on state, when it is grounded by the main electronics then the PSU is switched off.

There is an input connector to the supply implemented with a hard switch to provide the input voltage which is in the range 80-264 V.

Soft Power-Off Switch

There is a power-off switch on the front panel to switch OFF the product in a controlled way.

When the switch is actuated the firmware turns off several subsystems and stores information about the product in the EEROM, then it grounds the soft power off signal to the PSU to switch off the product. The main goal of the soft power off switch is to improve the reliability of the product powering off the systems and putting the product in a known state before the power off condition.

Front Panel

The user can interact with the printer in two ways: from the host via the I/O channels or directly via the front panel. The front panel is used to display messages (like the status of the machine or warnings), to configure the printer (like setting the print quality or defining the palette) and to send commands to it (cancel the job or print a demo for example). It is important to recognize that the configuration settings that can be sent with the header of one plot will apply just to that plot and won't override the front panel settings for subsequent plots.

The front panel module has an LCD display, 10 keys, 6 leds and one beeper.

The front panel display is a 128 x 64 pixel graphic LCD. Every pixel can be activated individually and the controller present on the front panel board allows us to have both text and graphics at the same time on the display. The display has an LED backlight to improve its viewing characteristics. The backlight can be turned ON and OFF by the software. The contrast of the LCD can also be adjusted.

The keys are distributed in four groups:

- 2 keys at the bottom left corner are used to select the **Print Quality** (Best, Normal or Fast) and Color/Grayscale printing. The LEDs on top of the keys show the selected option.
- 2 keys at the top left part are used to send commands directly to the printer: **Cancel** and **Form Feed and Cut**.
- 5 keys to the right of the display are used to navigate through the

menus: **Back**, **Enter**, **Up**, **Down** and **Menu**. (You can print a demo plot called Menu to get the complete menu tree).

- 1 key on the upper right corner is used to switch the power ON and OFF. This key is called soft power ON/OFF in contrast to the hard power ON/OFF switch located at the back of the printer. The beeper is used to provide audible feedback to the user.

Ink Delivery System (IDS)

The Ink Delivery System (IDS) delivers ink under pressure from the large capacity off-axis ink cartridges via permanently connected tubes to the high throughput printheads for the HP DesignJet 1050C and 1055CM Printers

The IDS consists of five major subsystems:

- The Ink Supply Station (ISS).
- The Tubes System.
- The Air Pressurization System (APS).
- The Ink Level Sensing (ILS).
- The Leak Detect System (LDS).

Ink Supply Station (ISS)

In the Printer, the ink cartridges reside inside the ink supply station (ISS). This module is situated on the left side of the machine. The ISS includes the plastic housing that surrounds the supplies, the latch mechanism, and the fluid and electrical connections to the Ink Cartridges. It also supports the Air Pressure System (APS), with an air pump and associated tubing, an air relief valve, and a pressure sensor. The APS forms a replaceable module clipped under the ISS.

These are the key functions of the ISS:

- Ink Cartridges support and location.
- Limit creep of cartridge side walls.
- Avoid incorrect insertion of colors and inks.
- Contain ink from leaks.
- Support the Air Pressurization System (APS).

Tubes System

The Tubes System is the assembly that performs these functions:

- Conduct the ink pumped from the Ink Cartridge to the Printhead.
- Conduct the air from the pump into the Ink Cartridge.
- Keep the ink in good condition until it is delivered to the printhead.
- Avoid leaks and minimize ink on customer.

The main functional groups of the Tubes System assembly are the tube routing, the tubes and the printhead fluid interconnect.

The tubes move back and forth inside the volume defined by the tube guides. The Tube guides are a pair of sheet metal parts with opposing U-shaped profiles. The tubes are constrained inside them, which helps avoid kinks. The main functions of the tube guides are:

- Support the tubes in both directions: horizontal and vertical.
- Provide an adequate sliding surface for the tube carrier.
- Allow easy access to the tubes in the event of replacement.

Due to fatigue stress limitations, the space between the tubes and the guides is a compromise between stress on the tubes and space available.

The tubes are routed in a horizontal loop and go over the carriage. The tubes are threaded inside a protective extrusion called the Tube Carrier. The tube carrier is a co-extruded part with two different materials that have two different functions:

- Base material. This material provides the structure of the part. It is rubber-like to avoid contributing too much in forces over the carriage. The material is cheap and fatigue resistant, but its high coefficient of friction and low wear resistance makes it inappropriate for use in the Tube Guides.
- Protection ribs. The Tube carrier profile outer parts that are susceptible to rubbing need to be protected. These ribs are made from a hard plastic with exceptional wear properties and a very low coefficient of friction.

The main functions of the tube carrier is to:

- Protect the tubes from wear and to keep them in order.
- Keep a low friction coefficient.
- Avoid push-pull forces being transmitted to the tubes.

Air Pressurization System (APS)

The APS is the system that provides and controls the pressurization of the ink in the Ink Cartridges. The key “mission” of this system is to ensure the minimum required ink pressure at the inlet to each Printhead respectively at the required print rates. Note that only a minimum pressure needs to be controlled since the purpose of this pressure is simply to refill the Printhead fast enough to maintain the Printhead’s internal pressure within its limits needed for drop-weight control. The APS is also used to provide pressure for tube purge and as part of the blow prime system operation.

The mechanism used is a low-pressure pneumatic system with feedback control of the air pressure.

The air circuit includes the Ink Cartridges, flexible air tubing, manifold connectors for the tubing, a DC motor driven air pump, a 2-way solenoid valve, and an analogue pressure sensor. Connection is made to each Ink Cartridge respectively by the same needle / septum system used for the ink; there is also a “quick connect” between the tubing and manifold that remains attached to the Tubes System and the APS Module.

The APS module is a service replaceable module that houses the pump, valve and sensor in one chassis which also doubles as an ink catcher: this assembly clips under the ISS Housing.

The APS pressurizes the ink in the cartridge bags by pressurizing the air around them. The printer controls the pressure of this air using the pump with feedback from the sensor; when required the valve is opened to de-pressurize the air circuit. This air pressure thereby controls the ink pressure at the inlet to the printheads. The system pressure for printing is set to ensure the defined Printhead inlet pressure for the highest possible flow rate.

Ink Level Sense (ILS)

The Printer includes a subsystem to monitor the amount of ink left in an off-axis ink supply, called Ink Level Sensing (ILS). The ink supplies used in the Printer consist of a collapsible ink bag inside a pressure shell. Two coils are attached to the external side of the bag and aligned with each other so that they form a variable transformer. The coupling coefficient of the transformer is a function of the distance between both coils, that is, it depends on the amount of

remaining ink. These two coils are part of a flex PCB that also includes the connection pads and the ink leak detection pads.

The ISS board includes the electronics required to measure the level of ink using this variable transformer. The circuit generates the excitation signal applied to the primary coil and reads both the current flowing through the primary coil and the voltage induced at the secondary coil. The secondary voltage vs. primary current ratio gives a measure of the coupling coefficient.

The measured ratio increases with decrease in ink remaining, but the relationship is not linear. Due to the complexity of the bag collapse process an empirical relationship has been developed using characterization data obtained in an experimental way. The ratio vs. remaining ink curves are different for each one of the available supply sizes (175 cc and 350 cc).

The ISS board also includes the circuitry needed to monitor the status of the reservoirs. It is possible to check the electrical continuity of both the primary and the secondary coils and also to detect if the bag has an ink leak. This last function is performed by measuring the current flow between the two ink leak detection pads located in the flex PCB.

Leak Detect System (LDS)

The purpose of the Leak Detect System (LDS) is to detect the breakage of any of the tubes that deliver ink from the Ink Cartridges to the Printheads.

With the tube routing, the tubes are continuously stressed in flexure. When the Carriage moves back and forth, the section of the tube that is stressed also moves causing fatigue cycling.

When a tube breaks, a small crack appears. As the system is pressurized, the ink flows through the crack and gets between the tube and the tube carrier, filling it.

The Carriage end of the tube carrier is sealed with an O-ring that has been overmolded to the tube carrier. This joint prevents the ink from going to the carriage. As one end of the tube carriage is plugged, the ink is forced to go to the other end, which is fixed to the Printer. At that point, below the end of the tube carrier there is an ink collector that retains the ink that drops from the tube carrier by gravity.

At the ink collector there are two metallic pins between which the resistance is checked. When there is no leakage, there will be air present and the resistance measured will be high. In case of leakage, the collector will contain ink and there will be a potential short circuit between both electrodes through the ink, and the ink leak will be detected.

The LDS measures the resistance in the collector: if this resistance is below the threshold value, then the system will assume there is ink in the collector and the Printer will be stopped.

Service Station

The Service Station consists of a linear motion mechanism with a chassis containing one PrintHead Cleaner (PHC) for each printhead. Each PHC consists of one spittoon and reservoir, sled-type cap nozzle wiper and pen snout wiper. Attached to the Service Station chassis, one optical drop detector provides nozzle check functionality.

Wipers are located symmetrically on the PHC. This, together with the Scan-axis Printhead to Printhead distance (32 mm) enables separate color / black wipe.

A positive pressure priming system is implemented that injects air into the printhead regulator bagafam to induce a controlled drooling. Airflow channels are integrated into the latching system springbeam, which deliver air to the bagafam ports. The priming pump is integrated into an articulating lever mounted on the right side of the service station. The priming process occurs with each printhead over its respective spittoon to handle waste ink and facilitate post-priming servicing routines.

Print Head Cleaner (PHC)

The PHC case is the main structural part of the replacement module. It is the part that the customer handles and contains the other sub-components:

- Wiper.
- Spittoon.
- Cleaning fluid.
- Cap sled assembly.

Cap

The purpose of the caps is to prevent the nozzles from drying out while the printer is idle. The caps seal off the printhead, forming a closed, high humidity chamber with small volume that is vented to ambient through a long and narrow passage. The caps self-align to the printheads by referencing features on each printhead.

Wiper

The function of wiping is to remove ink residue and external debris from the printhead so that good drop ejection and nozzle performance is maintained throughout the life of the printhead. Linear wiper motion will occur in the direction of the nozzle rows (orthogonal to direction of carriage motion) at 0.2 to 6.0 ips programmable speed. The maximum wiping force is 2N.

Spittoon

Spitting is the act of firing all the print head nozzles into a container (spittoon). Spitting into the spittoon is done routinely to clear the nozzles of viscous plugs and to clear any loose debris from the nozzles. PHC Spittoon is designed to hold 50 cc of spat ink (which has almost no water content due to evaporation).

In order to avoid ink spills when replacing PHC, color spittoons have foam that will keep the ink escaping due to capillary effect.

Black ink does not have foam. The Black ink is pigmented, and it has been proven that pigmented inks build up over any surface when spat, including foams, creating stalagmites that may hit the Printhead and cause some nozzles out.

Fortunately, black ink dries very fast, creating a solid block of ink that will not fall out off the spittoon when tilted. For most users, the probability of seeing enough liquid ink in the spittoon to create a spills problem is very low.

To prevent the growth of tall and narrow stalagmites that may reduce spittoon life, the Printhead spits in four different locations (Scan-axis), randomly.

Snout Wiper

Snout wiper is used to clean the ink accumulation that happens on the snout of the pen (vertical corner on the interconnect side) because of wiping operation. This is done to avoid spreading this ink over the interconnect when replacing the pen and generating ink shorts between interconnect pads.

Handle and Printable Label

The handle is used to remove and install the PHC. Also, the printer uses the handle top surface to print and scan some patterns in order to recognize if:

- PHC is present or not.
- PHC is new or has been used previously.

In addition, there is a built-in mark on the handle (a vertical hole) to calibrate the service station (Scan-axis) if there is a problem and the EEROM is erased.

Printer Specifications

Functional Specifications				
HP No.80 Supplies	Four colors: cyan, magenta, yellow and black.			
	Printheads:	600 dpi,	12.0 kHz (Cyan, Magenta, Yellow). 12.0 kHz (Black).	
	Printhead Cleaners:	Cyan, magenta, yellow and black.		
	Ink Cartridges:	Cyan, magenta, yellow, each containing 175cc or 350cc of ink Black contains 350cc of ink.		
Paper sizes	Width (carriage axis)		Length (paper axis)	
	Minimum	Maximum	Minimum	Maximum
Roll	610mm	917 mm	600 mm	The maximum length depends on the amount of memory the printer has.
Sheet	210 mm A/A4	E/A0	210 mm A/A4	1.6m
Paper types	Plain Paper HP Translucent bond HP Bright White Inkjet paper HP Vellum HP Coated paper HP Heavy coated paper HP High-gloss photo paper HP Matte film HP Clear film HP Natural tracing paper Thin natural tracing paper (greater than 70 g/m ²)			
From time to time, new paper types may become available. For up-to-date information, please contact your HP dealer or our web site www.designjet-online.hp.com . Also see the <i>Supplies Source</i> catalog and (in Europe and USA) <i>HP Paper Guide</i> . For alternative names, HP commercial names and physical characteristics of these paper types, see chapter 3.				
Print resolution by mode setting	Draft Normal Best	300 x 300 dpi. 600 x 600 dpi. 600 x 600 dpi. (Color prints) Addressable 1200 x 600 dpi. (Grayscale prints in Best)		

Functional Specifications				
	Roll (normal)	Sheet (normal)	Roll (extended)	Sheet (extended)
Margins	Side Margins 5mm Leading edge Margin 10mm Trailing Edge Margin 5mm	Side Margins 5mm Leading edge Margin 10mm Trailing Edge Margin 15mm	Side Margins 15mm Leading edge Margin 10mm Trailing Edge Margin 5mm	Side Margins 15mm Leading edge Margin 10mm Trailing Edge Margin 15mm
Programming languages supported	CALS G4 (Type I) HP-GL HP-GL/2 (with Kanji Level 1 and 2 character sets) HP-RTL (with color extensions) PJI, PML Adobe PostScript 3 (supports Asian languages) VareWare			
Accuracy	0.2% of the specified vector length at 23°C (73°F), 50-60% Relative Humidity, on HP special polyester film.			

Physical Specifications				
Type	Weight	Length	Depth	Height
E size printer	59 kg without stand 81 kg with stand	1566mm	675mm	1290mm

Memory Specifications		
Memory	Up to 128 Mbyte DRAM (2 x 64 Mb DIMMs)	2.0 Gb Hard Disk (As standard in the 1055CM)

Printer Power Specifications	
Source	100-240 V ac ±10% autoranging
Frequency	50-60 Hz
Current	3 amp maximum.
Consumption	200 watts maximum.
Energy Star rating (USA)	Maximum power in idle state: 45 watts.

Ecological Specifications	
Energy efficiency	Compliant with Energy Star Program EPA (US).
Manufacturing process	Free of ozone-depleting chemicals (Montreal Protocol).
Plastics	Free of brominated flame retardants (PBB and PBDE). All housing parts made of the same material: ABS. Parts marked according to ISO 11469 standard.
Metals	Enclosures made of electro-galvanized steel sheet.
Packaging	Cardboard (non-chlorine-bleached) and foam are 100% recyclable. Inks used for printing do not contain heavy metals.
User Documentation	Majority can be recycled, not bleached with chlorine and printed with inks that do not contain heavy metals. For specification of this <i>User's Guide</i> see the back cover.
Batteries	Not used.
Recyclability	Modular construction, connecting elements snap-type can be re-used, screws easy to find and disassembly done using universal tools.

Environmental Specifications		
Operating Range	Printing:	15°C to 35°C (59° F to 95° F) RH 20% to 80%.
	Optimal print quality:	22°C to 26°C (72° F to 79° F) RH 30% to 60%.
	Acceptable print quality:	15°C to 30°C (59° F to 86° F) RH 20% to 80%.
Non Operating Ranges	Printer:	-40°C to 70°C (-40° F to 158° F)
	Packed consumables and system:	-40°C to 60°C (-40° F to 140° F)

NOTE If the printer temperature falls below its minimum operating temperature it may stop to protect its ink systems.

NOTE At 3000m altitude the printer may have operational problems.

Acoustic Specifications	
Operating sound pressure	54 dB (From a one-meter bystander position)
Idle sound pressure	<30dB (A) (From a one-meter bystander position)
Operating sound power	6.5 Bels (A)
Idle sound power	<4.3 Bels (A)

EMC (ElectroMagnetic Compatibility) Specifications	
Canada	Canadian Department of Communications, Radio Interference Regulations Class B ¹ compliant.
European Union	89/336/EEC EMC Directive compliant. Meets EN 55022 Class B ¹ emission limits, prEN 55024-2 ESD, prEN55024-3 Radiated Immunity, prEN 55024-4 Fast Transients.
Japan	Registered VCCI Class B ¹ .
Korea	RRL certified.
South Africa	SABS licensed.
USA	Federal Communications Commission. Class B ¹ computing device. CFR 47 Part 15
Australia New Zealand	Meets AS/NZS 3548
Taiwan	BCIQ certified

¹ Product exhibits Class A operation when connected to LAN cables using Print Server accessories

Printer Safety Specifications	
Information Technology Equipment (ITE), Movable, Class I, Plugable Type A, Installation Category II, Pollution Degree 2, For indoor controlled office environments use.	
Canada	Canadian Standards Association “Certified” ITE, CSA C22.2 No.950
European Union	73/23/EEC Low Voltage Directive compliant. Meets EN 60950
Mexico	DGN, NOM019-SCFI-1994 certified
Norway	NEMKO approved, EN 60950, EMKO TSE(74)DK207/94
USA	Underwriters' Laboratories “Listed” ITE, UL 1950
China	CCIB certified GB 4943-90 1st Ed.
Czech Republic	EZU, IEC950 certified.
Singapore	PSB, SS337 certified.
Poland	PCBC certified.
Russia	GOST certified.

Printable Area

Printing Area (= Paper Size Minus Margins)						
	Paper Size (and Orientation of Paper)		Printing Area (Width x Height) by Orientation of Image			
			inches		millimeters	
			landscape	portrait	landscape	portrait
ANSI paper	A	(portrait)	9.5 x 7.2	7.2 x 9.5	243 x 185	185 x 243
	A	(landscape)	9.8 x 7.0	7.0 x 9.8	249 x 180	180 x 249
	B	(portrait)	15.5 x 9.8	9.8 x 15.5	395 x 249	249 x 395
	B	(landscape)	15.7 x 9.5	9.5 x 15.7	401 x 243	243 x 401
	C	(portrait)	20.5 x 15.7	15.7 x 20.5	522 x 401	401 x 522
	C	(landscape)	20.8 x 15.5	15.5 x 20.8	529 x 396	396 x 529
	D	(portrait)	32.5 x 20.7	20.7 x 32.5	827 x 528	528 x 827
	D	(landscape)	32.8 x 20.5	20.5 x 32.8	834 x 523	523 x 834
	E	(portrait)	42.6 x 32.8	32.8 x 42.6	1082 x 834	834 x 1082
Architectural paper	A	(portrait)	10.5 x 7.8	7.8 x 10.5	268 x 119	199 x 268
	A	(landscape)	10.8 x 7.6	7.6 x 10.8	275 x 193	193 x 275
	B	(portrait)	16.5 x 10.8	10.8 x 16.5	421 x 275	275 x 421
	B	(landscape)	16.8 x 10.5	10.5 x 16.8	427 x 269	269 x 427
	C	(portrait)	22.6 x 16.8	16.8 x 22.6	574 x 427	427 x 574
	C	(landscape)	22.8 x 16.5	16.5 x 22.8	580 x 421	421 x 580
	D	(portrait)	34.5 x 22.8	22.8 x 34.5	878 x 580	580 x 878
	D	(landscape)	34.8 x 22.6	22.6 x 34.8	884 x 574	574 x 884
	E1	(portrait)	40.5 x 28.8	28.8 x 40.5	1031 x 732	732 x 1031
E	(portrait)	46.5 x 34.8	34.8 x 46.5	1183 x 884	884 x 1183	
ISO paper	A4	(portrait)	10.2 x 7.0	7.0 x 10.2	261 x 180	180 x 261
	A4	(landscape)	10.1 x 6.8	6.8 x 10.1	257 x 174	174 x 257
	A3	(portrait)	15.1 x 10.5	10.5 x 15.1	384 x 267	267 x 384
	A3	(landscape)	14.9 x 10.2	10.2 x 14.9	380 x 261	261 x 380
	A2	(portrait)	21.9 x 14.9	14.9 x 21.9	558 x 380	380 x 558
	A2	(landscape)	22.2 x 15.1	15.1 x 22.2	564 x 384	384 x 564
	A1	(portrait)	31.6 x 21.8	21.8 x 31.6	805 x 554	554 x 805
	A1	(landscape)	31.5 x 20.6	20.6 x 31.5	801 x 524	524 x 801
	A0	(portrait)	45.3 x 31.5	31.5 x 45.3	1153 x 801	801 x 1153

For margins, see page 5-9. This table is calculated using normal margins.

Interface Specifications

Below are the parallel interface specifications.

For specifications of the HP JetDirect Print Server (Network Interface), see the JetDirect Print Server documentation supplied with the Print Server Interface or consult your dealer.

Parallel (IEEE-1284 compatible/Centronics) Interface			
<p>The connector on the printer is 36-pin female.</p> <p>Most existing parallel cables support IEEE-1284 compatible communication, but for use with this printer, the cable must meet the specification in this table.</p>	Pin	Wire/Signal Name	Source
	1	Strobe	computer
	2 ... 9	D0 ... D7 (data lines)	both
	10	Ack	printer
	11	Busy	printer
	12	PError	printer
	13	Select (SelectOut)	printer
	14	AutoFd	computer
	16	GND	
	19 ... 30	GND	
	31	Init	computer
	32	Fault	printer
36	SelectIn	computer	

The following cable is recommended for optimum performance and electromagnetic compatibility:

Recommended Cable for PCs and Unix Systems			
Interface type (Computer)	HP part number	Cable length	Connector type at computer end of cable
IEEE compatible/Centronics Interface (All)	C2951A	3.0 m	25-pin male

NOTE

There is a small serial port at the rear of the printer, this is there for manufacturing purposes only and cannot be used to print.

Regulatory Notices

To Obtain a Material Safety Data Sheet (MSDS)

You can obtain current Material Safety Data Sheets for the ink systems used in the printer by mailing a request to this address: **Hewlett-Packard Customer Information Center**, 19310 Pruneridge Avenue, Dept. MSDS, Cupertino, CA 95014, U.S.A. There is also a web page: <http://www.hp.com/abouthp/envrnmnt/contents/envfacts/hpmsds.htm>

Sound

**Geräuschemission
(Germany)**

LpA < 70 dB, am Arbeitsplatz, im Normalbetrieb, nach DIN 45635 T. 19.

Electro-Magnetic Compatibility (EMC)

**FCC Statements
(U.S.A.)**

The U.S. Federal Communications Commission (in 47 cfr 15.105) has specified that the following notices be brought to the attention of users of this product.

Product Identification Numbers:

Printer	DesignJet 1050C	DesignJet 1055CM
Model	C6074A	C6075A

This device complies with part 15 of the FCC rules. Operation is subject to the following two conditions: (1) This device may not cause harmful interference, and (2) this device must accept any interference received, including interference that may cause undesired operation.

Shielded cables

Use of a shielded data cables is required to comply with the Class B limits of Part 15 of the FCC Rules.

CAUTION

Pursuant to Part 15.21 of the FCC Rules, any changes or modifications to this equipment not expressly approved by the Hewlett-Packard Company, may cause harmful interference and void the FCC authorization to operate this equipment.

NOTE: This equipment has been tested and found to comply with the limits for a Class B digital device, pursuant to part 15 of the FCC Rules. These limits are designed to provide reasonable protection against harmful interference in a residential installation. This equipment generates, uses and can radiate radio frequency energy and, if not installed and used in accordance with the instructions, may cause harmful interference to radio communications. However, there is no guarantee that interference will not occur in a particular installation. If this equipment does cause harmful interference to radio or television reception, which can be determined by turning the equipment off and on, the user is encouraged to try and correct the interferences by one or more of the following measures:

- a** Reorient the receiving antenna
- b** Increase the separation between the equipment and the receiver
- c** Connect the equipment into an outlet on a circuit different from that to which the receiver is connected
- d** Consult the dealer or an experienced radio/TV technician for help

The user may find useful the following booklet prepared by the FCC: *“How to Identify and Resolve Radio-TV Interference Problems”*. This booklet is available from the US Government Printing Office, Washington, DC 20402, Stock No. 004-000-00345-4.

When connected to LAN cables using print server accessories...

This equipment has been tested and found to comply with the limits for a Class A digital device, pursuant to part 15 of the FCC Rules. These limits are designed to provide reasonable protection against harmful interference in a commercial environment. This equipment generates, uses and can radiate radio frequency energy and, if not installed and used in accordance with the instructions, may cause harmful interference to radio communications. Operation of this equipment in a residential area is likely to cause harmful interference in which case the user will be required to correct the interference at their own expense.

Normes de sécurité (Canada)

Le présent appareil numérique n'émet pas de bruits radioélectriques dépassant les limites applicables aux appareils numériques de Classe B prescrites dans le règlement sur le brouillage radioélectrique édicté par le Ministère des Communications du Canada.

Connecté à un réseau par des accessoires de serveur, l'appareil n'émet pas de bruits radioélectriques dépassant les limites applicables aux appareils numériques de Classe A prescrites dans le règlement sur le brouillage radioélectrique édicté par le Ministère des Communications du Canada.

DOC statement (Canada)

This digital apparatus does not exceed the Class B limits for radio noise emissions from digital apparatus set out in the Radio Interference Regulations of the Canadian Department of Communications.

When connected to LAN cables using print server accessories, this digital apparatus does not exceed the Class A limits for radio noise emissions from digital apparatus set out in the Radio Interference Regulations of the Canadian Department of Communications.

VCCI Class A and Class B (Japan)

この装置は、情報処理装置等電波障害自主規制協議会（VCCI）の基準に基づく第二種情報技術装置です。この装置は、家庭環境で使用することを目的としていますが、この装置がラジオやテレビジョン受信機に近接して使用されると、受信障害を引き起こすことがあります。

取り扱い説明書に従って正しい取り扱いをして下さい。

注意

IEEE802.3 もしくは Ethernet に接続されている場合、この装置は、情報処理装置等電波障害自主規制協議会（VCCI）の基準に基づく第一種情報技術装置です。この装置を家庭環境で使用すると電波妨害を引き起こすことがあります。この場合には使用者が適切な対策を講ずるよう要求されることがあります。

Korean EMI statement

이 기기는 업무용으로 전자파장애검정을 받은 기기이오니 판매자 또는 사용자는 이점을 주의하시기 바라며 만약 잘못 구입하였을 때에는 구입한 곳에서 비업무용으로 교환하시기 바랍니다

Taiwanese EMI statement**警告使用者：**

這是甲類的資訊產品，在居住的環境中使用時，可能會造成射頻干擾，在這種情況下，使用者會被要求採取某些適當的對策。

Tele-communications General Approval (UK)**Telecommunications Statement**

The HP DesignJet 1050C and 1055CM printers, models C6074 and C6075, are approved under Approval Number NS/G/1234/5/100003 for indirect connection to public telecommunication systems within the United Kingdom.

Address

Hewlett-Packard Company
 Manager of Corporate Product regulations
 3000 Hanover Street
 Palo Alto, CA 94304
 415/857-1501

Declaration of Conformity

DECLARATION OF CONFORMITY	
according to ISO/IEC Guide 22 and EN 45014	
Manufacturer's Name:	Hewlett-Packard Española S.A. Hewlett-Packard Singapore (PTE) Ltd.
Manufacturer's Address:	Barcelona Division Asia Hardcopy Manufacturing Operation Avenida Graells, 501 20 Gul Way 08190 Sant Cugat del Valles Singapore 629196 Barcelona, Spain
Declares that the product	
Product Name:	HP DesignJet 1050C and 1055CM Inkjet Printers
Model Number(s):	HP C6074X, HP C6075X
Product Accessory:	All
Conforms to the following Product Specification:	
Safety:	IEC 950 (1991)+A1,A2, A3, A4/ EN 60950 (1992)+A1,A2,A3,A4 CSA C22.2 No 950 (1995) UL 1950 (1995) NOM-019-SCFI-1994 EMKO-TSE (74) DK 207/94 GB 4943 (1995) IEC 825-1 (1993)/EN 60825-1 (1994) Class 1 for LED
EMC:	CISPR 22:1993 / EN 55022 (1994): Class B ⁽¹⁾⁽²⁾ EN 50082-1 (1992) IEC 801-2:1991/prEN 55024-2 (1992): 4KV CD, 8KV AD IEC 801-3:1984/prEN 55024-3 (1991): 3V/m IEC 801-4:1988/prEN 55024-4 (1993): 1KV Power Lines, 0.5KV Signal Lines IEC 1000-3-2:1995/EN 61000-3-2 (1995) IEC 1000-3-3:1994/EN 61000-3-3 (1995) FCC Part 15 - Class B/DOC-B/VCCI-B/RRL-A/BCIQ-A AS/NZS 3548 ⁽¹⁾ /GB9254:1988
Supplementary Information:	
The product herewith complies with the requirements of the Low-Voltage Directive 73/23/EEC and the EMC Directive 89/336/EEC and carries the CE marking accordingly.	
(1) Product exhibits class A operation when connected to LAN cables using print server accessories.	
(2) The product was tested in a typical system with a Hewlett Packard Personal Computer and second peripheral. An Apple Macintosh was used for Local Talk.	
Sant Cugat del Valles (Barcelona), September 30th 1998 Jordi Balderas, Quality Engineering Manager	Singapore, September 30th 1998 Kum Yew Chan, Quality Manager
European Contact: Your local Hewlett-Packard Sales and Service Office or Hewlett-Packard GmbH, Department HQ - 1 KE, Herrenberger Strasse 130, D-71034 Boeblingen, Germany (FAX: +49 7031 143143)	

www.designjet-online.hp.com



Direct access to HP and the information you want, when you need it. Register now!

HP DesignJet Online is a free, web-based “user club” exclusive to HP DesignJet users. Having registered, the user has unrestricted access to a range of useful services, the emphasis being on “useful”, as this is definitely *not* a sales-oriented site.

Communication from HP to users includes:

- a quarterly newsletter focussing on usage tips, technical briefings and examples of HP DesignJet applications around the world;
- full information on worldwide HP Customer Care contacts;
- an on-line *HP DesignJet Diagnosis* troubleshooting tool;
- a calendar of HP DesignJet-related events and programs;
- on-line access to training videos and selected user documents;
- and immediate information on new products.

Communication from the users to HP includes:

- feedback on HP DesignJet features;
- automatic contact with HP Customer Care from the troubleshooting tool, for HP to follow up;
- and the chance to ask technical questions on large-format printing to industry experts.

And finally, communication from user to user includes the chance to win prizes by submitting HP DesignJet success stories, as well as a user-to-user discussion forum where users can share best practices and ask for advice from their fellow professionals.

HP DesignJet Online is available in English, German, French, Italian, Spanish and Portuguese.

Glossary

ac

Alternating current.

ANSI size

An American standard media size; e.g. D, E

application

The software you use to create your drawings.

APS

Air Pressurization System

Centronics

A standard for the parallel interface between computer and device.

clipping

Losing part of a drawing at the edges.

CMYK

Cyan, magenta, yellow and black. The colors of the printer's four inks, and also a standard color model.

coated paper

Paper coated on one side for inkjet printing.

default

A value or condition that is assumed if no other value or condition is specified.

device

An external item connected to the computer: printer, plotter, tape drive, etc. Your HP DesignJet is a device.

dpi

Dots per inch, a measure of print resolution.

driver

The software that controls the communication between a computer and a device.

front panel

The control panel on the right of the printer.

front-panel menus

The structure of options in the front-panel display.

graphics language

A programming language telling a print device how to output graphic data.

grayscale

Shades of gray to represent colors.

high-gloss film

A glossy, opaque, polyester media type.

high-gloss photo

A glossy, opaque photographic paper.

Glossary

HP-GL/2

One of Hewlett-Packard's standard graphics languages for plotters and printers. Produces vector data. Newer than HP-GL.

IDS

Ink Delivery System.

I/O Input/output

The transmission of data between a computer and a device.

inked area

The smallest rectangle that contains all the content of the drawing, while maintaining its relative dimensions.

ISO size

An international standard media size; e.g. A1, A2, etc.

ISS

Ink Supply Station

JIS size

A Japanese standard media size.

LAN

Local area network.

LDS

Leak Detect System

long-axis printing

Printing a page whose X-axis (the axis vertical to the printer as you look at it from the front) is longer than a standard page size.

margin

The space around the page added by the printer to separate one page from another and to avoid printing right to the edge of the media.

matte

Not glossy.

media

The material, usually paper, onto which the printer prints.

nesting

Placing two or more pages side-by-side on roll media to avoid waste.

palette

A set of logical pens defined by color and width.

Paper-axis

The vertical axis, as you look at the printer from the front.

PJL

Printer Job Language. A programming language that controls jobs going to a printer.

PML

Printer Management Language.

parallel interface

A type of interface between computer and device. Generally faster than a serial interface.

PANTONE

The PANTONE MATCHING SYSTEM® is an international standard for color communication in the graphics art industry.

pen

Even though the plotter has no physical pens, the lines it draws match the attributes of a pen.

platen

The exterior part of the printer on which the media rests before going into the media-entry slot.

printing area

Page size minus margins.

PostScript

A standard page-markup language, commonly used by graphics and desktop publishing software applications.

PSU

Power Supply Unit.

queueing

Placing each print received by the device into memory for processing with other prints.

raster

A method for defining an image, in terms of dots rather than lines. Raster data typically needs more memory than vector data.

RGB

Red, green and blue. A standard color model.

RIP

Raster Image Processor.

RTL (Raster Transfer Language)

One of Hewlett-Packard's standard graphics languages for plotters and printers. Produces raster data.

ROM DIMM

A physical module containing read-only data, that can be installed in the back of the printer to provide upgrades.

Scan-axis

The horizontal axis, as you look at the printer from the front.

semi-gloss photo

A semi glossy, opaque photographic paper.

spindle

The rod which holds the roll of media.

Glossary

Index

A

Accessories 7-34
Accuracy Calibration 5-6
Acoustic Specifications 10-14
Air Pressurization System 8-20, 10-7
APS Assembly 7-14

B

Back Cover 8-32
Banding 1-12, 6-9
Baudrate Selection 4-42
Belt 8-44
Belt Swelling 9-2

C

Calibrations Backup 5-19
Cam 8-73
Cap 10-10
Carriage Assembly 7-18, 8-44
Carriage Height Calibration 5-24
Carriage Interconnect Wiper 3-18
Center Guide 7-30, 8-71
Cleaning
 General 9-2
 Overdrive 9-3
 Printer 9-2
Clutch Assembly 7-16, 8-21
Color Accuracy Configuration 6-23
Color changes when stacking 1-10

Color differences 1-11
Color to Color calibration 5-16
Cut Sheet 1-13
Cutter Assembly 8-42

D

Declaration of Conformity 10-22
Drive Roller 7-28, 8-70
Drop Detector 8-10
Drop Detector Service Test 4-22

E

Ecological Specifications 10-14
EEROM Utilities 4-38
EIO Card Service Test 4-10
Electrical System 10-2
Electro-Magnetic Compatibility 10-18
Electronic Systems Service Test 4-5
Electronics Module 7-6, 8-25
EMC Specifications 10-15
Encoder Strip 8-34
Environmental Specifications 10-14

F

Front Panel 8-6, 10-4
Front Panel Display 3-7
Front Platen Assembly 8-62
Front-Panel Menu 1-15

Index

Functional Overview

- Air Pressurization System 10-7
- Electrical System 10-2
- Ink Level Sense 10-7
- Ink Supply Station 10-5
- Leak Detect System 10-8
- Power Supply Unit 10-3
- Print Head Cleaner 10-9
- Service Station 10-9
- Soft Power-Off Switch 10-4
- Tubes System 10-6

Functional Specifications 10-12

H

- Hard Disk Drive Service Test 4-12
- HP DesignJet Online 10-23
- HP No.80 Supplies 3-2
 - General Information 3-4
 - HP No.80 Supplies 3-5
 - replacing 3-6
 - solving problems 3-17
- Hue shift 1-12

I

- Ink Cartridge Status Messages
 - Empty 3-11
 - Faulty 3-12
 - Low 3-11
 - Reseat 3-12
 - Status bars 3-11
 - Unknown 3-12
 - Very Low 3-11
 - Wrong Model 3-12
- Ink Cartridges 3-2
 - obtaining information 3-8
- Ink Delivery System 10-5
- Ink Leak Detector 8-60
- Ink Level Sense 10-7
- Ink Pressure System Service Test 4-14
- Ink Supply Station 8-19, 10-5

Installing

- Air Pressurization System 8-20
- Carriage Assembly 8-51
- Electronics Module 8-27
- Platen Assembly 8-63
- Right Hand Cover 8-6
- Trailing Cable 8-40
- Interface Specifications 10-17
- ISS Assembly 7-14

L

- Leak Detect System 10-8
- Left Hand Cover 7-10, 8-13
- Left Hand Trim 8-18
- Left Rear Cover 8-24
- Level of Printer Usage 9-3
- Line Sensor Calibration 5-9
- Long term bleed 1-12
- Lower image gloss 1-13

M

- Media 6-24
- Media Holder Strip 8-69
- Media Jams 1-7
- Media Sensor 7-30, 8-29
- Memory Specifications 10-13
- Moisture on the Printer 9-2

N

- No Printing Defects 6-21
- Noisy Carriage Bushing 9-2
- Nozzle Defects 6-7
- Nozzle Print Test 6-6

O

- Overdrive Cleaning 4-37

P

Paper Axis Service Test 4-20
 Paper Entry Assembly 8-64
 Paper Path 7-24
 Paper-axis Motor 8-12
 Parts List

- APS Assembly 7-14
- ARSS Miscellaneous Parts 7-22
- Carriage Assembly 7-18
- Center Guide 7-30
- Clutch Assembly 7-16
- Drive Roller Assemblies 7-28
- Electronics Module 7-6
- Ink Supply Station 7-14
- Left Hand Cover 7-10
- Media Sensor 7-30
- Paper Path Assemblies 7-24
- Pinch Assembly 7-26
- Printer Support 7-2
- Rear Covers 7-4
- Right Hand Assemblies 7-12
- Right Hand Cover 7-8
- Scan-Axis Assemblies 7-20
- Tubes Guide Assemblies 7-32
- Window 7-10

 Pen Alignment 5-22
 Physical Specifications 10-13
 Pinch Assembly 7-26
 Pinch-Wheel Assembly 8-73
 Platen Assembly 8-63
 Power Supply Unit 10-3
 Preventive Maintenance Kit 9-4
 Priming the Ink System 3-6
 Print Head Cleaner 10-9
 Print Modes 6-3
 Print Quality

- Troubleshooting 6-13
- Troubleshooting Checklist 6-2

 Print Quality Test 6-4
 Printable Area 10-16
 Printer doesn't power ON 1-5
 Printer Model Type 4-35
 Printer Power Specifications 10-13
 Printer Safety Specifications 10-15

Printer Specifications 10-12
 Printer Support 7-2
 Printhead Check 4-41
 Printhead Cleaners 3-2
 Printhead Crashes 1-7, 1-10
 Printhead rejection 1-6
 Printhead Smears 1-10
 Printhead Status Messages

- Failed 3-14
- Faulty 3-16
- Insert 3-15
- Monitor 3-15
- OK 3-13
- Replace 3-13
- Reseat 3-16
- Setup 3-15
- Unknown 3-16
- Used 3-15
- Wrong Model 3-16

 Printheads 3-2

- obtaining information 3-9

 Problems

- Color Accuracy 6-22
- Color Alignment 6-8
- Color Consistency 6-22
- Color-to-Color Alignment 6-15
- Cover Sensors 1-6
- Horizontal Lines 6-17
- Line Sensor 1-6
- Long Term Color Bleeding 6-22
- Media-handling 1-14
- Printing lines 6-14
- Stepped lines 6-13
- Vacuum Fan 1-9
- Vacuum suction 1-9

R

Rear Covers 7-4
 Rear Platen 8-23
 Regulatory Notices 10-18
 Release Info 4-32

Index

Removing

- Air Pressurization System 8-20
- Back Cover 8-32
- Belt 8-44
- Carriage Assembly 8-44
- Center Guide 8-71
- Clutch Assembly 8-21
- Cutter Assembly 8-42
- Drive Roller 8-70
- Drop Detector Assembly 8-10
- Electronics Module 8-25
- Encoder Strip 8-34
- Front Panel Assembly 8-6
- Front Platen Assembly 8-62
- Ink Leak Detector Assembly 8-60
- Ink Supply Station Assembly 8-19
- Left Hand Cover 8-13
- Left Hand Trim Assembly 8-18
- Left Rear Cover 8-24
- Media Holder Strip 8-69
- Media Sensor 8-29
- Paper Entry Assembly 8-64
- Paper-axis Motor Assembly 8-12
- Pinch-Wheel Assembly and Cam 8-73
- Platen Assembly 8-63
- Rear Platen 8-23
- Right Hand Cover 8-4
- Right Hand Trim 8-7
- Right Rear Cover 8-24
- Roller Guide 8-66
- Scan-axis Motor Assembly 8-33
- Service Station Assembly 8-8
- Tail Deflectors 8-23
- Tensioner 8-37
- Top Cover 8-31
- Trailing Cable 8-39
- Tubes System Assembly 8-53
- Vacuum Fan 8-11
- Window 8-30
- Window Switch 8-7

Required Tools 8-3

Rice Paper 1-13

Right Hand Assemblies 7-12

Right Hand Cover 7-8, 8-4

Right Hand Trim 8-7

- Right Rear Cover 8-24
- Roller Guide 8-66
- Roller Mark Position Calibration 5-13

S

- Scan Axis Service Test 4-17
- Scan-Axis Assemblies 7-20
- Scan-axis Maintenance 9-4
- Scan-axis Motor 8-33
- Scheduled Maintenance 9-3
- Scratches on prints 1-11
- Scratching 6-24
- Service Calibrations 1-3
 - Accuracy Calibration 5-6
 - Calibrations Backup 5-19
 - Carriage Height Calibration 5-24
 - Color to Color calibration 5-16
 - Entering 5-4
 - Line Sensor 5-9
 - Pen Alignment 5-22
 - Pen to Paper Spacing 5-15
 - Roller Mark Position 5-13
 - Service Station 5-11
- Service Configuration Print 1-19
- Service Station 8-8, 10-9
- Service Station Calibration 5-11
- Service Tests 1-3
 - Drop Detector 4-22
 - EIO Card 4-10
 - Electronic Systems 4-5
 - Entering 4-4
 - Hard Disk Drive 4-12
 - Ink Pressure System 4-14
 - Paper Axis 4-20
 - Scan Axis 4-17
- Service Utilities
 - EEROM Utilities 4-38
 - Entering 4-26
 - Mon. Mode Baud Sel. 4-42
 - Overdrive Cleaning 4-37
 - Printer Model Type 4-35
 - Printhead Check 4-41
 - Release Info 4-32

- Set Asian PS Fonts 4-33
 - Tubes Purge 4-28
 - Set Asian PS Fonts 4-33
 - Shielded cables 10-18
 - Smears 6-24
 - Snout Wiper 10-11
 - Soft Power-Off Switch 10-4
 - Solving
 - Image Quality Problems 1-3
 - Sound 10-18
 - Spittoon 10-10
 - System Error Codes 2-2
 - 0000D8 2-3
 - 010020 2-3
 - 010021 2-4
 - 010023 2-4
 - 01002D 2-3
 - 010040 2-5
 - 010041 2-5
 - 010042 2-6
 - 010050 2-6
 - 01009X 2-7
 - 02xxxx 2-7
 - 048xxx 2-8
 - 04Cxxx 2-8
 - 060301 2-9
 - 060305 2-9
 - 060309 2-10
 - 06030A 2-10
 - 06030B 2-11
 - 070100 2-11
 - 080001 2-12
 - 09xxxx 2-12
 - 0A0000 2-13
 - 0A0010 2-13
 - 0A0020 2-14
 - 0A0030 2-14
 - 0A0040 2-14
 - 0A0050 2-15
 - 0A0060 2-15
 - 0A0070 2-16
 - 0B0000 2-18
 - 0B0001 2-18
 - 0B0002 2-18
 - 0B0003 2-19
 - 0B0004 2-19
 - 0B0005 2-19
 - 0B0006 2-20
 - 0B0007 2-20
 - 0B0008 2-20
 - 0B0009 2-21
 - 0B000A 2-21
 - 0B000B 2-22
 - 0B000C 2-22
 - 0B000D 2-22
 - 0C0030 2-16
 - 0C0032 2-17
 - 0C1000 2-17
 - 0C1001 2-17
 - Continuable 2-2
 - Non-Continuable 2-2
- ## T
- Tail Deflectors 8-23
 - Tensioner 8-37
 - Top Cover 8-31
 - Trailing Cable 8-39
 - Troubleshooting
 - Shutdowns 1-7
 - System Error Codes 1-2
 - Tubes Guide Assemblies 7-32
 - Tubes Purge 4-28
 - Tubes System 8-53, 10-6
- ## V
- Vacuum Fan 8-11
- ## W
- Window 7-10, 8-30
 - Window Switch 8-7
 - Wiper 10-10
 - Worm marks 1-13

About this Edition

This is the 1st edition of this Service Manual

1st edition, titled

HP C6074A/C6075A DesignJet 1050C and 1055CM Service Manual



What's in this Service Manual

This manual contains information necessary to test, calibrate and service:

- HP DesignJet 1050C (model C6074A)
- HP DesignJet 1055CM (model C6075A)

For information about using these printers, refer to the corresponding User and Quick Reference Guides.

The procedures described in this manual are to be performed by HP-qualified Service Personnel only.

HP

DesignJet 1050C/1055CM

Large-Format Printers