

# Universal Eight Zone Remote Point Module Installation Instructions

**FEATURES**

The ADEMCO 4208U Remote Point Module (RPM) is an 8-zone expander which allows use of the available expansion zones provided by ADEMCO controls that support polling loop devices. Characteristics of this device include:

- Can be optionally powered from an external DC power supply to reduce current draw from the polling loop
- Uniquely identifies 8 EOLR supervised zones (all zones use 10k resistors, supplied)
- DIP Switches can be used to set zone numbers or serial numbers
- When used in the serial number mode, each serial number in the selected group can be assigned to any zone number.
- Loops A&B can be programmed for fast (10 msec) response
- Tamper protected

**MOUNTING**

	<ol style="list-style-type: none"> <li>1. Power should be disconnected before proceeding.</li> <li>2. Be sure to mount the 4208U before making any wiring connections.</li> </ol>
--	---

When mounted inside the cabinet with the control, the 4208U should be mounted horizontally and does not need to be tamper protected. Insert two screws into the raised metal tabs leaving the heads app. 1/8" exposed, then hang the 4208U using the two slots on the back. When mounted in the cabinet, the 4208U does not need to be tamper protected or have the cover on, except in UL installations.

When mounted remotely, the 4208U can be mounted horizontally or vertically. Tamper protection should be enabled via the DIP switches and the cover put on. If tamper protection is required, be sure to enable the expansion zone tamper option at the control (program field \*24=0). Tamper protection is provided by a magnet on the cover and a reed switch mounted on the device. If the cover is opened, a trouble will be sent to the control for every active zone on the 4208U module.

<b>UL</b>	<ol style="list-style-type: none"> <li>1. For UL Listed Commercial Burglary, the 4208U must be tamper protected or mounted in a tamper protected cabinet.</li> <li>2. For all UL installations, the cover must be on the unit, even if the unit is mounted in the control's cabinet.</li> </ol>
-----------	---

**WIRING**

Polling loop and protection loop wires can be brought in either through the back or front of the unit by removing the knockouts. Use 22 gauge twisted pair wire for polling loop connections. All protection loops use 10k EOL resistors (included). A maximum resistance of 300 ohms

is allowed on protection loops (excluding EOLR). See Figure 2 for all connections. Keep in mind that connections to the polling loop are always required, while power supply connections are optional.

**DIP SWITCH SETTINGS**

Zone Assignment Mode:

In the zone assignment mode, the DIP Switches on the 4208U are used to assign the unit to a group of 8 consecutive zones. These zone numbers, once designated for the 4208U, cannot be used for anything else, even if you don't use all 8. Follow the steps below using Table 1 for DIP Switch settings:

Serial Number Mode:

In the serial number mode, the DIP Switches on the 4208U are used to assign the unit to a group of 8 serial numbers. You can assign any serial number to any zone number (except hardwire zone numbers on the control), and you do not lose zone numbers if you don't use all eight loops on the 4208U. Follow the steps below using Table 2 for DIP Switch settings:

Set the DIP Switches on the 4208U as instructed below (see Figure 1):

1. Select fast/slow response for loops A and B using DIP Switch 1: Fast = OFF (10msec); Slow = ON (400msec).
2. Select mode of operation (serial number or zone assignment mode) using DIP Switch 6: Serial Number mode = ON; Zone Assignment mode = OFF.

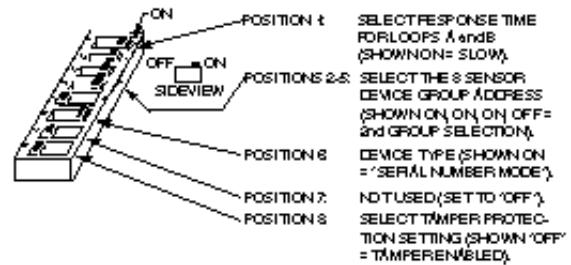

Figure 1: DIP Switch Settings

3. Select the group setting using Dip switches 2,3,4,and 5. See Table 1 for zone assignments or Table 2 for serial number assignments. If using more than one 4208U, be sure to set each one to a different group setting.
4. DIP Switch 7: Not Used, set to OFF.
5. Select the 4208U Tamper Protection setting using DIP Switch 8: Tamper Disabled = ON; Tamper Enabled = OFF. Tamper will report for every active zone on the 4208U module.

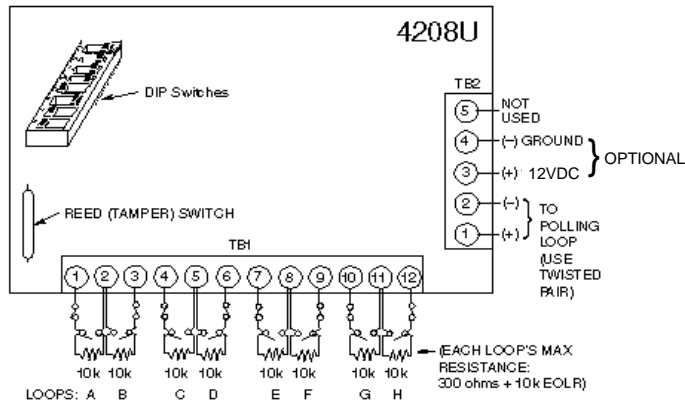

Figure 2: Summary of Connections

**For "Zone Assignment" mode, DIP Switch position 6 must be Off.**

When using this mode, program each zone's "Input Type" as "DIP Switch Polling Loop Device" (DP), where applicable.

THIS SWITCH SETTING PRESETS THE LOOPS TO THESE ZONE NUMBERS					Loop Designation								
DIP Switch Position ("—" means "off")					A	B	C	D	E	F	G	H	
2	3	4	5	6	1	2	3	4	5	6	7	8	*
on	on	on	on	—	9	10	11	12	13	14	15	16	**
on	on	—	on	—	17	18	19	20	21	22	23	24	
on	on	—	—	—	25	26	27	28	29	30	31	32	
on	—	on	on	—	33	34	35	36	37	38	39	40	
on	—	on	—	—	41	42	43	44	45	46	47	48	
on	—	—	on	—	49	50	51	52	53	54	55	56	
on	—	—	—	—	57	58	59	60	61	62	63	64	
—	on	on	on	—	65	66	67	68	69	70	71	72	
—	on	on	—	—	73	74	75	76	77	78	79	80	
—	on	—	on	—	81	82	83	84	85	86	87	88	
—	on	—	—	—	89	90	91	92	93	94	95	96	
—	—	on	on	—	97	98	99	100	101	102	103	104	
—	—	on	—	—	105	106	107	108	109	110	111	112	
—	—	—	on	—	113	114	115	116	117	118	119	120	
—	—	—	—	—	121	122	123	124	125	126	127	N/A	***

Zone Number

\*Do not select 1-8 for VISTA controls.

\*\*If 9-16 is selected for controls that have 9 hardwire zones, Loop A (Zone 9) will be inactive.

\*\*\*Accommodates option "ONE 4208 IN USE" if referred to in control programming.

NOTE: Consult the Control Panel Instructions to determine the valid zone numbers for that control panel.

Table 1: 4208U Zone Assignments

**For "Serial Number" mode, Dip Switch position 6 must be On.**

THIS SWITCH SETTING PRESETS THE LOOPS TO THESE SERIAL NUMBERS					Loop Serial Number							
Dip Switch position ("—" means "off")					(Each serial number in the selected group can be assigned to any zone number.)							
2	3	4	5	6	LOOP A	LOOP B	LOOP C	LOOP D	LOOP E	LOOP F	LOOP G	LOOP H
ON	ON	ON	ON	ON	000-0004	000-0005	000-0006	000-0007	000-0012	000-0013	000-0014	000-0015
ON	ON	ON	—	ON	005-9908	005-9909	005-9910	005-9911	005-9916	005-9917	005-9918	005-9919
ON	ON	—	ON	ON	013-9912	013-9913	013-9914	013-9915	013-9920	013-9921	013-9922	013-9923
ON	ON	—	—	ON	020-9716	020-9717	020-9719	020-9719	020-9724	020-9725	020-9726	020-9727
ON	—	ON	ON	ON	027-9620	027-9621	027-9622	027-9623	027-9628	027-9629	027-9630	027-9631
ON	—	ON	—	ON	034-9624	034-9625	034-9626	034-9627	034-9632	034-9633	034-9634	034-9635
ON	—	—	ON	ON	041-9428	041-9429	041-9430	041-9431	041-9436	041-9437	041-9438	041-9439
ON	—	—	—	ON	048-9332	048-9333	048-9334	048-9335	048-9340	048-9341	048-9342	048-9343
—	ON	ON	ON	ON	055-9236	055-9237	055-9238	055-9239	055-9244	055-9245	055-9246	055-9247
—	ON	ON	—	ON	062-9140	062-9141	062-9142	062-9143	062-9146	062-9149	062-9150	062-9151
—	ON	—	ON	ON	069-9044	069-9045	069-9046	069-9047	069-9052	069-9053	069-9054	069-9055
—	ON	—	—	ON	076-8946	076-8949	076-8950	076-8951	076-8956	076-8957	076-8958	076-8959
—	—	ON	ON	ON	083-8852	083-8853	083-8854	083-8855	083-8860	083-8861	083-8862	083-8863
—	—	ON	—	ON	090-8756	090-8757	090-8758	090-8759	090-8764	090-8765	090-8766	090-8767
—	—	—	ON	ON	097-8660	097-8661	097-8662	097-8663	097-8668	097-8669	097-8670	097-8671
—	—	—	—	ON	104-9564	104-9565	104-9566	104-9567	104-9572	104-9573	104-9574	104-9575

Table 2: 4208U Serial Number Assignments

**PROGRAMMING**

When setting the 4208U to a group of zone numbers , each zone must be programmed as follows:

On 4140XMP and earlier controls, these zones must be programmed as Left Loop Polling Loop zones.

On Vista-40 and later controls, these zones must be programmed in the #93 Menu Mode Zone Programming as INPUT TYPE "7"--DIP Switch type polling loop device (DP).

When setting the 4208U to a group of serial numbers , each zone must be programmed as INPUT TYPE "6"--SL (Serial Number Polling Loop Device). Loops can be learned in any order and assigned to any legitimate zone number.

When prompted to Learn the serial number for a particular zone, you may either enter it manually through the keypad or through V-Link, or "learn" it in by momentarily faulting (shorting) the terminals of that zone as required by the control. If entering a serial number manually through the keypad, enter it and press "\*" to advance to the next prompt, which will ask you for the loop number. Enter a "1" for each serial number entered.

If learning or entering a serial number, and the message

"Duplicate of Zone XX" is displayed, another device with that same serial number is already in the system. In that case, use a different serial number group setting on the 4208U.

	If learning a serial number by faulting its associated loop, be sure that other polling loop devices are not activated, as they may interfere with the device being learned.
---	--

**VERIFICATION OF PROGRAMMING**

To verify proper programming, the following test should be performed:

1. Be sure to enable expansion zone tamper protection at the control (program field \*24 = 0).
2. Set DIP Switch 8 to OFF (tamper enabled).
3. Replace the 4208U cover and clear the keypad of any faulted zones.
4. Remove the 4208U's cover and verify (on the keypad) that only the zones you designated for this 4208U are indicating a check (or trouble) condition.

Power Input Source (Input Voltage: 11 - 14VDC)	Current Draw (all zones shorted)	
	From Polling Loop	From External Power
Polling Loop Only	27.3 mA	
Polling Loop and External Power Input	0.6 mA	28 mA

Table 3: Current Draw Calculations

**SPECIFICATIONS**

Physical:

Width: 6-7/6" (163mm)

Height: 4-1/4" (108mm)

Depth: 1-1/4" (32mm)

Electrical:

Polling loop input: 7.3 - 14VDC

Current draw: 28.6mA max. external power and polling loop (see Table 3)

External Power Input (optional):

12VDC @28mA (from control panel's auxiliary power)

Sensor Loop Response:

Slow: 400msec (all loops)

Fast: 10msec (option for loops A and B)

Sensor Loop Current:

(@ polling loop input= 11VDC, no external power input):

0.52mA (normal)

1.3mA (shorted)

Sensor Loop Max. Resistance:

Up to 300 ohms of wire resistance + 10k EOLR.

<p>For UL Listed Commercial Fire Usage: Use N.O. contacts. Style B supervise these loops using Model #EOL100 fire listed 10k EOLRs (purchased separately).</p> <p>For UL Listed Commercial Burglary Usage: Use: N.O. or N.C. contacts. Supervise using EOLRs supplied.</p>
--

## ADEMCO Limited Warranty

Alarm Device Manufacturing Company, a Division of Pittway Corporation, and its divisions, subsidiaries and affiliates ("Seller"), 165 Eileen Way, Syosset, New York 11791, warrants its products to be in conformance with its own plans and specifications and to be free from defects in materials and workmanship under normal use and service for 24 months from the date stamp control on the product or, for products not having an Ademco date stamp, for 12 months from date of original purchase unless the installation instructions or catalog sets forth a shorter period, in which case the shorter period shall apply. Seller's obligation shall be limited to repairing or replacing, at its option, free of charge for materials or labor, any product which is proved not in compliance with Seller's specifications or proves defective in materials or workmanship under normal use and service. Seller shall have no obligation under this Limited Warranty or otherwise if the product is altered or improperly repaired or serviced by anyone other than Ademco factory service. For warranty service, return product transportation prepaid, to Ademco Factory Service, 165 Eileen Way, Syosset, New York 11791.

THERE ARE NO WARRANTIES, EXPRESS OR IMPLIED, OF MERCHANTABILITY, OR FITNESS FOR A PARTICULAR PURPOSE OR OTHERWISE, WHICH EXTEND BEYOND THE DESCRIPTION ON THE FACE HEREOF. IN NO CASE SHALL SELLER BE LIABLE TO ANYONE FOR ANY CONSEQUENTIAL OR INCIDENTAL DAMAGES FOR BREACH OF THIS OR ANY OTHER WARRANTY, EXPRESS OR IMPLIED, OR UPON ANY OTHER BASIS OF LIABILITY WHATSOEVER, EVEN IF THE LOSS OR DAMAGE IS CAUSED BY THE SELLER'S OWN NEGLIGENCE OR FAULT.

Seller does not represent that the products it sells may not be compromised or circumvented; that the products will prevent any personal injury or property loss by burglary, robbery, fire or otherwise; or that the products will in all cases provide adequate warning or protection. Customer understands that a properly installed and maintained alarm may only reduce the risk of a burglary, robbery, fire or other events occurring without providing an alarm, but it is not insurance or a guarantee that such will not occur or that there will be no personal injury or property loss as a result. CONSEQUENTLY, SELLER SHALL HAVE NO LIABILITY FOR ANY PERSONAL INJURY, PROPERTY DAMAGE OR OTHER LOSS BASED ON A CLAIM THE PRODUCT FAILED TO GIVE WARNING. HOWEVER, IF SELLER IS HELD LIABLE, WHETHER DIRECTLY OR INDIRECTLY, FOR ANY LOSS OR DAMAGE ARISING UNDER THIS LIMITED WARRANTY OR OTHERWISE, REGARDLESS OF CAUSE OR ORIGIN, SELLER'S MAXIMUM LIABILITY SHALL NOT IN ANY CASE EXCEED THE PURCHASE PRICE OF THE PRODUCT, WHICH SHALL BE THE COMPLETE AND EXCLUSIVE REMEDY AGAINST SELLER. This warranty replaces any previous warranties and is the only warranty made by Seller on this product. No increase or alteration, written or verbal, of the obligations of this Limited Warranty is authorized.

### FEDERAL COMMUNICATIONS COMMISSION (FCC) Part 15 STATEMENT

This equipment has been tested to FCC requirements and has been found acceptable for use. The FCC requires the following statement for your information:

This equipment generates and uses radio frequency energy and if not installed and used properly, that is, in strict accordance with the manufacturer's instructions, may cause interference to radio and television reception. It has been type tested and found to comply with the limits for a Class B computing device in accordance with the specifications in Part 15 of FCC Rules, which are designed to provide reasonable protection against such interference in a residential installation. However, there is no guarantee that interference will not occur in a particular installation. If this equipment does cause interference to radio or television reception, which can be determined by turning the equipment off and on, the user is encouraged to try to correct the interference by one or more of the following measures:

- If using an indoor antenna, have a quality outdoor antenna installed.
- Reorient the receiving antenna until interference is reduced or eliminated.
- Move the radio or television receiver away from the receiver/control.
- Move the antenna leads away from any wire runs to the receiver/control.
- Plug the receiver/control into a different outlet so that it and the radio or television receiver are on different branch circuits.

If necessary, the user should consult the dealer or an experienced radio/television technician for additional suggestions. The user or master may find the following booklet prepared by the Federal Communications Commission helpful:

"Interference Handbook"

This booklet is available from the U.S. Government Printing Office, Washington, DC 20402.

*The user shall not make any changes or modifications to the equipment unless authorized by the Installation Instructions or User's Manual. Unauthorized changes or modifications could void the user's authority to operate the equipment.*

SEE THE CONTROL PANEL'S INSTALLATION INSTRUCTIONS FOR COMPLETE INFORMATION REGARDING THE LIMITATIONS OF THE ENTIRE SECURITY SYSTEM.



165 Eileen Way, Syosset, New York 11791

Copyright © 1997 PITTWAY CORPORATION