

S9200U1000 Universal Hot Surface Ignition Integrated Furnace Control

INSTALLATION INSTRUCTIONS

APPLICATION

The S9200U1000 Universal Integrated Furnace Control is a combustion control used in single stage gas heating and cooling appliances. Keyed wire harnesses allow the S9200U1000 to replace most furnace controls and to be applied to most heating and cooling single stage appliances.

The S9200U1000 can be used with conventional thermostats as well as the EnviraCOM™ enabled VisionPRO IAQ and FocusPRO. The S9200U1000 Universal Integrated Furnace Control is intended for residential natural or liquid propane fueled furnaces only.

The S9200U1000 EnviraCOM™ communications capability allows its use in twinning applications and enables communication with local and remote diagnostic devices such as the QuickLook hand held device (QuickLook™ 72), EnviraLNK® web-based application and the W8735D Telephone Access Module (TAM).

FEATURES

The S9200U1000 provides:

- **Main burner ignition using a 120V hot surface igniter.**
- **Flame rectification circuit to monitor flame presence.**
- **Monitoring of system pressure switch, high temperature limit, and rollout functions.**
- **Appliance operation/safety requirements controlled via microprocessor.**
- **Control of a standard induction-type circulating fan motor (based on appliance requirements), in response to a conventional low voltage or EnviraCOM™ thermostat.**
- **LED system status, performance and diagnostic indication.**
- **Wire harnesses provided for simple replacement of most IFCs and integration with most heating and cooling appliances.**
- **Twinning capability.**
- **EnviraCOM™ communication capability to enable local and/or remote system status, diagnostics, troubleshooting, and HVAC system control.**

SPECIFICATIONS

Line Voltage: Line 120V (97-132 Vac), 60 Hz

Low Voltage: Line 24V (19-30 Vac), 60 Hz

Current Draw: 0.5A Input Current @24 Vac, plus valve load @ 24 Vac plus cooling contactor

Igniter Current: 5.0A resistive @ 132 Vac output

Thermostat Anticipator Setting: (Stage 1 only) 100mA

Prepurge: 30 seconds

HSI Warm-up: 17/27 or 30/30 seconds (1st/next trial) depending on DIP switch S2 setting

Trial for Ignition: 4, 6, or 8 seconds depending on DIP switch S2 setting

Postpurge: 15 seconds

Inter-trial Purge: 60 seconds

Auto Restart Delay: 60 minutes (after Soft Lockout)

Ignition Trials: Three; two retries if flame is not sensed on the first trial

Flame Failure Response Time: 2 seconds maximum @ 1µA

LEDs: Three LEDs provide the following:

- A red LED provides system status and faults
- An amber LED provides flame status information
- A green LED provides information about the EnviraCOM™ traffic

Wire harnesses:

- 12 pin, 3 x 4 connector, 7 inches; main harness
- 4-pin, 4 x 1 connector, 7 inches; igniter/inducer harness

Fan Delays:

Heat Fan ON Delay: 30 or 60 seconds depending on DIP switch S1 setting

Heat Fan OFF Delay: 60, 90, 120, or 180 seconds depending on Dip Switch S1 setting

Cool Fan ON Delay: 5 seconds

Cool Fan OFF Delay: 0 or 60 seconds (depending on DIP Switch S1 setting)

Gas Control: Any 24 Vac redundant, direct ignition gas control rated at 1.5A or less; Honeywell VR88345M4320 recommended

Cooling Contactor:

Any 24 Vac contactor rated at 1.0A or less

Induced Draft Blower:

2.2FLA/3.5LRA maximum @ 120 Vac

Circulator Load: 14.5FLA/25LRA maximum @ 120 Vac

Line Voltage Humidifier:

1A resistive load maximum @ 120 Vac

Electronic Air Cleaner:

1A resistive load maximum @ 120 Vac

Replaceable Fuse: 3.0 Amp, Automotive type

Operating Temperature: -40°F to 175°F (-40°C to 79°C)

Relative humidity: 0% to 95% non-condensing

Dimensions: See Fig. 1 on page 6



INSTALLATION AND CONFIGURATION OVERVIEW

- Configure the field settings and safety timings. See "Safety Timings, Field Settings, and Fixed Parameters" beginning on page 11.

The following is an overview of the steps required to install and configure the S9200U1000 Integrated Furnace Control:

- Identify cross reference target using Table 1.
- Remove old device and carefully identify and mark any wiring. See "Replacement" on page 6.
- Mount the S9200U1000 Integrated Furnace Control. See "Replacement" on page 6.
- Connect the wiring harnesses and make the wiring connections. See "Wiring" on page 7.

CROSS REFERENCE

IMPORTANT

Only use the S9200U1000 on 120 Vac applications.

See Table 1 for the replacement details for other manufacturers' controls.

Table 1. S9200U1000 Replaces These Integrated Furnace Controls.
[Only use the S9200U1000 on 120 Vac applications.]

SKU	Harness	Field Settings Recommendation - DIP Switch S1 (See Table 8 on page 11)	Safety Timing Settings - DIP Switch S2 (See Table 9 on page 12)
United Technologies	50024568 Main Connector	SW1: ON SW2: OFF SW3 & SW4: 60/90/120/180	SW1: ON SW2: ON
1012-925A			
1012-925B			
1012-925C			
Rheem/ Robert Shaw			
62-24268-01			
62-24268-02			
62-24268-03			
695-200	50024566 Inducer & HSI Connector	SW1: ON SW2: OFF SW3 & SW4: 60/90/120/180	SW1: ON SW2: ON
Nordyne			
624557			
6245570			
624557-0			
624564			
6245640			
624591			
624591A			
624591-A			
624591-B			
624591-C			
624591-D			
624628			
624628-0			
6246310			
624631-0			
624631A			
624631-A			
624631-B			
710128A			
902378			
902696			
903106			
CAR903106			

**Table 1. S9200U1000 Replaces These Integrated Furnace Controls.
[Only use the S9200U1000 on 120 Vac applications.] (Continued)**

SKU	Harness	Field Settings Recommendation - DIP Switch S1 (See Table 8 on page 11)	Safety Timing Settings - DIP Switch S2 (See Table 9 on page 12)
United Technologies	50024568		
1012-955A	Main Connector	SW1: ON SW2: OFF	SW1: ON SW2: OFF
1012955A	50024565	SW3 & SW4: 60/90/120/180	
	Inducer & HSI Connector		
Texas Instruments			
6DT-1			
6DT-2			
61F3			
York			
03100662000			
031-00662-000			
031-00662-700			
031-01140-000			
031-01140-001			
031011140002			
031-01140-002			
031-01140-701			
031-01140-702			
031.01234.000			
031-01234-700			
031-01235-000			
031-01235-700			
031-01250-000			
031-01266-000			
031-01267-00	Main Connector not required.		
031-01267-000	50024561	SW1: ON SW2: OFF SW3 & SW4: 60/90/120/180	SW1: OFF SW2: ON
031-01267-001	Inducer & HSI Connector		
031-01267-001A			
031-01284-000			
031-01933-000			
031-01972-000			
031-01973-000			
031-02166-000			
031-09166-000			
031-09167-000			
331-01933-000			
331-01972-200			
331-09167-000			
43101972100			
431-01972-100			
CAR33101972200			
CAR03101973000			
CAR50A55843			
G951ADB1401			
G951ADB1401C			
G951ADB-1401C			
G951ADB1402			

Table 1. S9200U1000 Replaces These Integrated Furnace Controls.
[Only use the S9200U1000 on 120 Vac applications.] (Continued)

SKU	Harness	Field Settings Recommendation - DIP Switch S1 (See Table 8 on page 11)	Safety Timing Settings - DIP Switch S2 (See Table 9 on page 12)
York (continued)	Main Connector not required. 50024561 Inducer & HSI Connector	SW1: ON SW2: OFF SW3 & SW4: 60/90/120/180	SW1: OFF SW2: ON
G951ADB-1402			
G951AEB-1403			
P03101267001			
P031-01267-001			
PTH031011400-00			
United Technologies			
1012-83-9651B			
White Rodgers			
50A50-209			
50A50-230			
50A55-241			
Goodman	50026393 Main Connector 50026446 Inducer & HSI Connector	SW1: ON SW2: OFF SW3 & SW4: 60/90/120/180	SW1: OFF SW2: ON
1809913			
18099-13S			
B180996			
B1809906			
B18099-6			
B18099-06			
B1809908			
B18099-08			
B1809910			
B18099-10			
B18009910			
B180099-10			
B1809913			
B18099-13			
B1809913S			
B18099-13S			
B18009913			
B180099-13			
CARB1809913S			
United Technologies			
1012-930			
1012933D			
1012-933D			
1012-83-9336AHSC1			
1012-83-9337A			
Texas Instruments			
41F-5			
White Rodgers			
50T35730			
50T35-730			
50T35743			
50T35-743			

Table 1. S9200U1000 Replaces These Integrated Furnace Controls.
[Only use the S9200U1000 on 120 Vac applications.] (Continued)

SKU	Harness	Field Settings Recommendation - DIP Switch S1 (See Table 8 on page 11)	Safety Timing Settings - DIP Switch S2 (See Table 9 on page 12)
ICM280	50026393 Main Connector 50026446 Inducer & HSI Connector	SW1-SW4: Check control Field Settings before setting.	SW1-SW2: Check control Safety Timings before setting.
White Rodgers			
50A55-843 - Universal	50024561 Inducer & HSI Connector	SW1: Check Settings SW2: Check Settings SW3 & SW4: 60/90/120/180	SW1: OFF SW2: OFF
50A55-120		SW1: OFF SW2: OFF SW3 & SW4: 60/90/120/180	SW1: OFF SW2: OFF
50A55-286		SW1: ON SW2: OFF SW3 & SW4: 60/90/120/180	SW1: OFF SW2: ON
50A55-438		SW1: Check Settings SW2: OFF SW3 & SW4: 60/90/120/180	SW1: OFF SW2: OFF
50A55-474		SW1: Check Settings SW2: OFF SW3 & SW4: 60/90/120/180	SW1: OFF SW2: OFF
50A55-571		SW1: Check Settings SW2: OFF SW3 & SW4: 60/90/120/180	SW1: OFF SW2: OFF
50A50-143		SW1: ON SW2: Check Settings SW3 & SW4: 60/90/120/180	SW1: OFF SW2: ON
50A50-286		SW1: ON SW2: OFF SW3 & SW4: 60/90/120/180	SW1: OFF SW2: ON
50A50-438		SW1: Check Settings SW2: ON SW3 & SW4: 60/90/120/180	SW1: OFF SW2: ON

INSTALLATION

When Installing This Product...

1. Read these instructions carefully. Failure to follow them could damage the product or cause a hazardous condition.
2. Check the ratings given in these instructions to make sure the integrated furnace control is suitable for your application.
3. Installer must be a trained, experienced service technician.
4. After installation is complete, check out operation as provided in these instructions.

WARNING

Fire or Explosion Hazard.

Can cause severe injury, property damage, or death.

1. The integrated furnace control can malfunction if it gets wet, leading to accumulation of explosive gas.
 - Never install where water can flood, drip or condense on the control.
 - Never try to use an integrated furnace control that has been wet—replace it.
2. Liquefied petroleum (LP) gas is heavier than air and will not naturally vent upward.
 - Do not operate electric switches, lights, or appliances until you are sure the appliance area is free of gas.

⚠️ WARNING

Electrical Shock Hazard.
Can cause severe injury, property damage, or death.

1. Make sure to turn power off to the furnace.
 Failure to do this may result in electrical shock or equipment damage
2. Disconnect power supply before beginning wiring or making wiring connections to prevent electrical shock or equipment damage.

⚠️ CAUTION

Equipment Damage Hazard.
Water can cause equipment damage or malfunction.

If furnace control must be mounted near water or moisture, provide suitable waterproof enclosure.

7. From Table 1 on page 2, identify the wiring harness(es) required for the quick installation of the S9200U1000. The provided wiring harness adapters are intended to connect to the existing wiring harness. See Table 2 on page 7 and Table 3 on page 8 for pin-out information for the provided wiring harnesses.
8. Connect the appropriate end of the wiring harness to the 12-pin plug on the S9200U1000 (if required) and the other end to the existing wiring plug (previously removed from the existing furnace control). Connect the appropriate igniter/inducer harness (if required) to the 4 pin plug and the other end to either the existing plug or spade connectors (previously removed from the existing furnace control).

IMPORTANT

The provided wiring harnesses are keyed. Do not force the connection if the plug on the harness and receptacle on the S9200U1000 do not easily snap closed.

9. Connect the quick-connect cables to the appropriate contacts on the S9200U1000
10. Set the Safety timings as required using switch S2. Refer to Table 9 on page 12 for switch setting information.
11. Set the field selectable timings as required using switch S1. Refer to Table 8 on page 11 for setting information.
12. Review the connections to insure no wiring is loose and there is a proper earth ground to the appliance chassis.
13. Turn power ON to the appliance. See "Checkout" on page 13 and the control sequence diagrams, Fig. 9- Fig. 11 beginning on page 17.

Replacing An Existing Furnace Control

Location

In most cases the integrated furnace control is mounted on a panel within the circulator compartment of the furnace. The location must provide:

- Access to the field wiring terminals.
- Operating ambient temperatures between -40°F and 175°F (-40°C and 79°C).
- Relative humidity below 95% non-condensing.
- Protection from water, steam or corrosive chemicals that are used to clean the appliance.
- Protection from dripping water, such as from an overfilled humidifier or from condensation.
- Protection from dust or grease accumulation.

IMPORTANT

Be sure to identify the safety timings on the existing furnace control before any wires are disconnected. If this information is unavailable, check with the furnace manufacturer for recommended settings.

Replacement

To replace the existing furnace control:

1. Remove the access panel to gain access to the furnace control.
2. Unclip the wiring harness from the furnace control and identify/mark all wires not connected to a wiring plug.
3. Once the furnace control is free from all wiring, either unclip or unscrew the furnace control from the base plate.
4. Select the location within the appliance most suitable so that all existing cables or required harnesses will reach without straining either the cables or the plugs. We recommend mounting the S9200U1000 in the same location as the old furnace control, if possible. Ambient temperature at the S9200U1000 must be within the control specifications.
5. The S9200U1000 can be mounted vertically in any orientation. See Fig. 4 on page 9 for typical mounting orientation.
6. Secure the board to the mounting panel base plate with the two sheet metal screws inserted through the eyelets located on the edges of the board. See Fig. 1 on page 6.

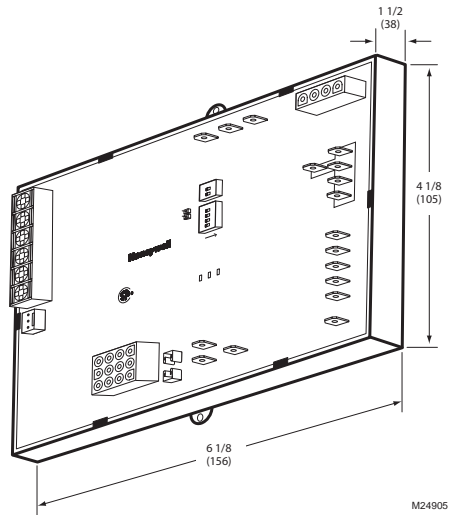

Fig. 1. S9200U1000 dimensions in inches and (mm).

Wiring

! WARNING

Fire or Explosion Hazard.
Can cause severe injury, property damage, or death.

Make sure the proper wiring harness is used. Check the cross reference tables (Table 1 on page 2) and review the appliance wiring schematic.

The S9200U1000 is intended to connect to the appliance with the aid of wiring harnesses. Carefully review the wiring harness selection table for the correct wiring harnesses. See Table 1 on page 2.

Check the wiring diagram (Fig. 4 on page 9) and the diagram furnished by the appliance manufacturer for all terminal designations. Table 4 and Table 5 beginning on page 8 describe the wiring connections for Class 2 and Class 1 installations.

Typical wiring connections are shown in Fig. 5 on page 10.

Check the wiring diagrams furnished by the appliance manufacturer, if available, for circuits that differ from the general hookup shown. Carefully follow any special instructions affecting the general procedures outlined below.

All wiring must comply with local codes and ordinances.

See "Wiring Harnesses" for the main and igniter/inducer harness plug connections and details.

See "Wiring Connections" on page 8 for wiring connections, but also refer to furnace manufacturer instructions, if available.

NOTE: The Safety Timing jumper is described in Table 6 on page 11.

IMPORTANT

The common ground required for the S9200U1000 and the main burner must be supplied through the plug connected to the Main Harness (12-pin connector) receptacle on the board.

Wiring Harnesses

The following describes the main and igniter/inducer harness connections.

MAIN HARNESS PLUG CONNECTIONS

The following describes the harness plug connectors for the main harness. See Table 2 and Fig. 2.

IMPORTANT

The common ground required for the S9200U1000 and the main burner must be supplied through the plug connected to the Main Harness (12-pin connector) receptacle on the board.

Table 2. Main Harness Plug Connector 12-pin (Class 2, Low Voltage).

Pin #	Function
1	High Limit Out
2	Flame Sense - Flame Signal Input (90 Vac, current limited)
3	24 Vac Hot
4	Not Used
5	Rollout Switch Out
6	24 Vac Common
7	High Limit In + Pressure Switch Out
8	Chassis Ground
9	Main Valve Common
10	Pressure Switch In
11	Rollout Switch In
12	Main Valve

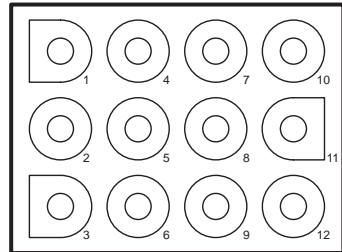

M24906

Fig. 2. S9200U1000 Main harness plug configuration.

IGNITER/INDUCER HARNESS PLUG CONNECTIONS

The following describes the harness plug connectors for the igniter/inducer. See Table 3 and Fig. 3.

Table 3. Igniter/Inducer Harness Plug Connector 4-pin (Class 1, Line Voltage).

Pin #	Reference Lettering	Function
1	IND-HOT	Inducer 120 Vac
2	IGN-HOT	Igniter 120 Vac
3	IND-NEUTRAL	Inducer Neutral
4	IGN-NEUTRAL	Igniter Neutral

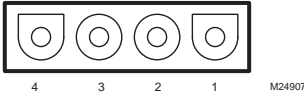

Fig. 3. S9200U1000 Igniter/Inducer harness plug configuration.

Wiring Connections

Table 4 describes the wiring connections for Class 2 voltages.

Table 5 describes the wiring connections for Class 1 voltages.

See Fig. 5 on page 10 for wiring connection locations on the board.

Table 5. Wiring Connections (Class 1, Line Voltage).

Terminal Type	Connection (see Fig. 4 on page 9)	Connects S9200U1000 to:
4-pin connector (male terminals)	Igniter-Inducer Harness Connector	See Table 3
Straight Spade Quick-connect	COOL	Circulator cool speed output
	EAC	Electronic Air Cleaner 120 Vac output
	HEAT	Circulator heat speed output
	CONT	Continuous circulation
	XFMR	Transformer 120 Vac output
	L1	Line 120 Vac hot power supply
	HUM	Humidifier 120 Vac output
	PARK	Circulator Motor Park 120 Vac input
Straight Spade Quick-connect	Neutrals	Any neutral connector can be used for: <ul style="list-style-type: none"> • 120 Vac Input neutral • Transformer neutral • Electronic air cleaner neutral • Circulator neutral • Humidifier neutral
	Flame	Flame Sense - Signal input (90 Vac, current limited)

Table 4. Wiring Connections (Class 2, Low Voltage).

Terminal Type	Connection (see Fig. 4 on page 9)	Connects S9200U1000 to:
6-position screw terminal (#5 screw)	D/1 (optional)	EnviraCOM™ data connection (if used)
	C/3	24 volt ground
	R/2	24 volt hot - Thermostat
	W	Thermostat heat input
	G	Thermostat continuous fan input
	Y	Thermostat cool input / cooling contactor output for EnviraCOM™ thermostats
Polarized 3-pin connector	E-COM	EnviraCOM™ diagnostic or communications device
12-pin connector	Main Harness Connector	See Table 2 on page 7
Straight Spade Quick-connect	24 Vac	Transformer - 24 Vac
	COM	Transformer - Common
Fuse Block	Fuse	Fuse - Automotive Type - 3.0 Amps

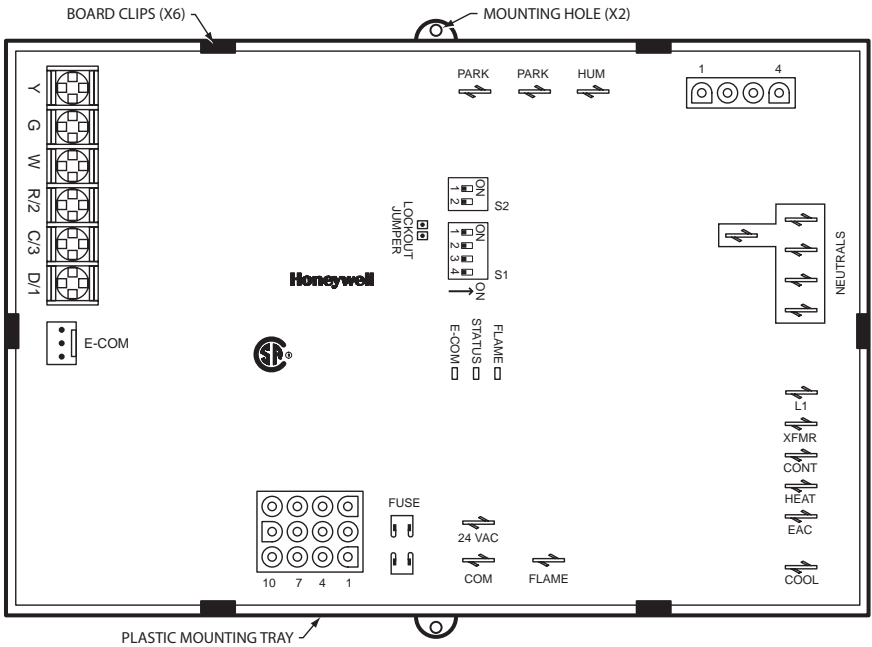

M24908A

Fig. 4. Typical mounting orientation showing wiring connections and components of the S9200U1000 Universal Integrated Furnace Control.

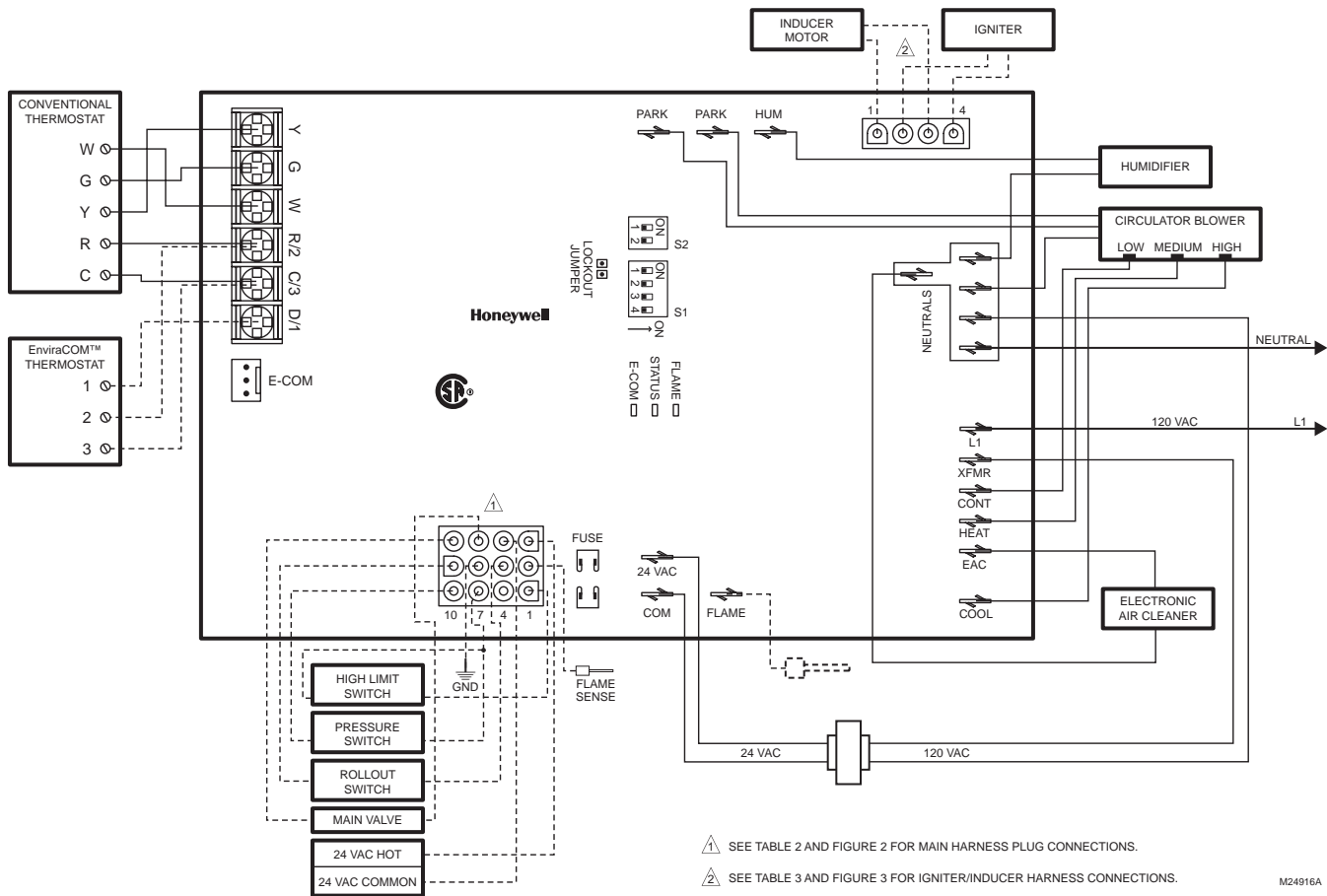

Fig. 5. Typical wiring connections for S9200U1000 Universal Integrated Furnace Control.

M24916A

SAFETY TIMINGS, FIELD SETTINGS, AND FIXED PARAMETERS

⚠ WARNING

Fire or Explosion Hazard.
Can cause severe injury, property damage, or death.

Field Settings and Safety timings must comply with OEM specifications. Do not extend Safety timings beyond those recommended. Failure to follow recommended safety timings may result in equipment damage, bodily injury, or death!

IMPORTANT

Extending the Safety timing beyond that recommended by the appliance OEM may result in unburned gas accumulation in the appliance which can cause an explosion!

Safety Timing Lockout Jumper

The S9200U1000 is equipped with a Safety Timing Lockout Jumper intended to make safety timings permanent once they are selected. To insure that resetting the Safety Timing DIP switches (Table 9 on page 12) can not cause a hazardous condition, remove the Safety Timing Lockout Jumper once the Safety Timing DIP switch position selection is made.

In case the S9200U1000 Safety Timing Lockout Jumper (see Table 6) is not removed after the DIP switch selection is made, the DIP switch settings will be permanently stored in the control's non-volatile memory after the 10th full cycle each time the DIP switch is set. Once permanently stored, the Safety Timings can not be changed.

See See "DIP Switch S2 - Safety Timings" on page 12.

Table 6. Safety Timing Lockout Jumper.

Jumper (see Fig. 4 on page 9)	Remove jumper to enable
Lockout	After setting the Safety Timing DIP switch (S2), remove the jumper to permanently store the settings into the non-volatile memory of the S9200U1000.

Field Settings

The field settings can be changed whenever necessary. The change takes effect for the next situations which are being influenced by that change. If for example a particular delay is in progress and settings are changed, the current delay setting is not influenced by that change. The field settings are not considered safety critical therefore, changes to these parameters can be made at any time during and after installation.

See "DIP Switch S1 - Field Settings" on this page.

Fixed Parameters

Fixed parameters are those settings which may not be adjusted at any time.

Table 7 describes the S9200U1000 Fixed parameters.

Table 7. Fixed Parameters.

Fixed Parameter	Setting
Pre-Purge	30 seconds
Inter-trial Purge	60 seconds
Postpurge	15 seconds
Cool Fan ON Delay	5 seconds
Ignition Retries	2 retries (3 retries total)
Ignition Recycles	3 recycles (4 cycles total)
Auto Restart Delay	1 hour
Flame Failure Response Time	2 seconds (maximum)
Fault De-bouncing Time	2 seconds
Compressor Short Cycle Delay	5 minutes
False Flame Recognition Period	20 seconds
Heat Cycles to Safety Timings Selection Lock	10 cycles

DIP Switch (S1 and S2) settings

The following field and safety parameters may be set using DIP switches S1 and S2. Refer to Fig. 4 on page 9 for the location of the two DIP switch blocks.

DIP Switch S1 - Field Settings

Table 8 and Fig. 6 describe the S2 DIP switch settings. The default factory settings are all OFF and are shown in **bold**.

Table 8. DIP Switch (S1) Settings - Field Settings.

DIP Switch S1 Descriptions	Individual Switches			
	SW1	SW2	SW3	SW4
Cool Fan OFF Delay - 0 seconds	OFF			
Cool Fan OFF Delay - 60 seconds	ON			
Heat Fan ON Delay - 30 seconds		OFF		
Heat Fan ON Delay - 60 seconds		ON		
Heat Fan OFF Delay - 120 seconds			OFF	OFF
Heat Fan OFF Delay - 180 seconds			OFF	ON
Heat Fan OFF Delay - 90 seconds			ON	OFF
Heat Fan OFF Delay - 60 seconds			ON	ON

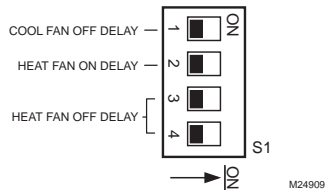

Fig. 6. DIP Switch (S1) shown with factory default settings; all OFF.

COOL FAN OFF DELAY TIMING

The Cool Fan Off Delay is the time period after the call for cooling has ended and before the deactivation of the blower motor at the cool speed. The timing is factory-set

to zero (0) seconds. To change it, first disconnect the power, then set SW1 on DIP switch S1 according to Table 8 on page 11.

HEAT FAN ON DELAY TIMING

The Heat Fan Off Delay is the period between entering the Trial for Ignition period and the activation of the blower motor at the heat speed (if the Trial for Ignition is successful). The default factory setting is 30 seconds. To change it, first disconnect the power, then set SW2 on DIP switch S1 according to Table 8 on page 11.

HEAT FAN OFF DELAY TIMING

The Heat Fan Off Delay is the period between the loss of supervised main burner flame after the call for heat has ended and the deactivation of the blower motor at the low heat speed. The timing is factory-set to 120 seconds. To change it, first disconnect the power, then set SW3 and SW4 on DIP switch S1 according to Table 8 on page 11.

DIP Switch S2 - Safety Timings

Table 9 and Fig. 7 describe the S1 DIP switch settings. The default factory settings are all OFF and are shown in bold.

Table 9. DIP Switch (S2) Settings - Safety Timings.

DIP Switch S2 Descriptions	Individual Switches	
	SW1	SW2
HSI Igniter Warm-up Time = 17/27 ^a seconds Trial For Ignition = 4 seconds: – Ignition Activation Period = 1 second – Flame Recognition Period = 3 seconds This is the default setting.	OFF	OFF
HSI Igniter Warm-up Time = 17/27 ^a seconds Trial For Ignition = 6 seconds: – Ignition Activation Period = 3 seconds – Flame Recognition Period = 3 seconds	OFF	ON
HSI Igniter Warm-up Time = 30/30 seconds Trial For Ignition = 6 seconds: – Ignition Activation Period = 3 seconds – Flame Recognition Period = 3 seconds	ON	OFF
HSI Igniter Warm-up Time = 30/30 seconds Trial For Ignition = 8 seconds: – Ignition Activation Period = 5 seconds – Flame Recognition Period = 3 seconds	ON	ON

^a The shorter of the two periods listed (17 seconds) applies to the first trial only, while the longer period (27 seconds) applies to the subsequent trials during the same call for heat.

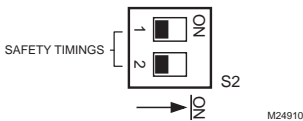

Fig. 7. DIP Switch (S2) shown with factory default settings; all OFF.

THERMOSTAT TYPE

The S9200U1000 will accept either a conventional 24 Vac, 1-Stage Heat, 1-Stage Cool thermostat or the VisionPRO or FocusPRO EnviraCOM™ enabled thermostats.

NOTE: When using a conventional 24 Vac thermostat, set the Heat Anticipator to 0.1 A.

TWINNING

EnviraCOM™ communication between two S9200U1000 controls permits the controls' use in Twinning applications. When a second S9200U1000 is sensed on the EnviraCOM™ Bus, each S9200U1000 control proceeds into Twinning Mode. If one of the two S9200U1000 controls is removed from a Twinning application, the remaining control reverts back to standard operation only after power to the control is cycled.

For twinning applications, Honeywell recommends that DIP switch S1 be set to the same positions on each device so that the heat/cool fan on/off delay times are equal for both devices. Otherwise, the shorter Fan On delay and the longer Fan Off Delay times are used for both devices.

See Fig. 8 for typical wiring connections.

IMPORTANT

1. For Twinning applications, two S9200U1000 controls must be used.
2. Always power down appliances when wiring the controls in Twinning applications. Failure to do so may result in delays in the control's registration on the EnviraCOM™ Bus.
3. Fan timing changes may be detected when two appliances are Twinned.

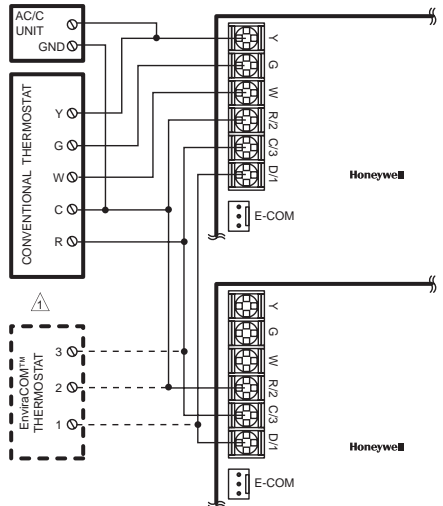

⚠ USE ONLY ONE THERMOSTAT WITHIN THE SYSTEM.

M24917A

Fig. 8. Typical wiring for Twinning application.

CHECKOUT

Check out the control system:

- At initial installation of the appliance.
- As part of regular maintenance procedures.
- As the first step in troubleshooting.
- Any time work is done on the system.

LED Indicators

The S9200U1000 provides three indicating LEDs; see Fig. 4 on page 9 for location on board:

- **Flame - Amber:** indicates flame status
- **Status - Red:** indicates general system status and error codes.
- **E-COM - Green:** indicates EnviraCOM™ bus activity

See “Troubleshooting” on page 19 for information about specific flash codes as referenced in the checkout procedures.

Use the following procedures only for the integrated furnace control; see individual component instructions for additional checkout procedures.

I. CHECK NORMAL OPERATION

Check Conventional 24 Vac Thermostat

1. Turn on power to the appliance.
2. After power is switched on, the furnace control can accept a W request after approximately 20 seconds, and Y and G requests after approximately 10 seconds.
3. Set the thermostat to call for heat. Make sure the S9200U1000 control sequences the system as indicated in Fig. 9 on page 17.
4. Set the thermostat below the room temperature to end the call for heat. The burner should go out; the induced draft fan should provide Postpurge time (15 seconds); and after the delay time, the indoor fan should stop.

There are three modes of operation. They are discussed in this next section in the following order:

1. Normal Heat Mode
2. Normal Cooling Mode – see page 14
3. Fan Mode – see page 14

Normal Heat Mode

Refer to Fig. 9 on page 17 for the Heat Mode control sequence diagram. The following describes the operation during a call for heat and the heat cycle.

Call for Heat

A call for heat is signaled by the thermostat closing the contacts between R/2 and W or an EnviraCOM™ heat demand. Requests for heat are ignored if there is a call for cooling at the Y terminal.

Upon a call for heat:

- The S9200U1000 conducts a safe start check that consists of an internal hardware/software self-check and verification there is no main burner flame present.
- The S9200U1000 verifies the Limit and Rollout switch circuits are closed.

- The S9200U1000 verifies the pressure switch circuit is open.
- The S9200U1000 energizes the inducer.
- After the Pressure Switch closes, Prepurge begins.
- After the completion of Prepurge, the HSI is energized for the Igniter Warm-up Period.
- When the Igniter Warm-up Period expires, the gas valve is energized and the Trial for Ignition begins.
- During the Ignition Activation Period, both the HSI element and the gas valve remain energized.
- After Ignition Activation, the HSI is de-energized and the gas valve remains energized for the Flame Recognition Period.
- The Heat Fan On Delay is started upon entering Trial for Ignition.
- When flame is sensed during Trial for Ignition, the S9200U1000 de-energizes the HSI and proceeds to normal run mode operation.
- Once the Heat Fan On Delay has expired, the circulator is energized on heat speed.

Call for Heat Satisfied

When the call for heat has ended:

- The gas valve is de-energized.
- The Postpurge and circulator fan off delay timings begin when the loss of flame is detected.
- The inducer is de-energized when the Postpurge Period is completed.
- The circulator is de-energized when the circulator fan off delay has expired.

Ignition Retry

When flame is not sensed during the Trial for Ignition or is lost less than 10 seconds after exiting Trial for Ignition:

- The gas valve is de-energized.
- The inducer remains energized during the Interpurge Period.
- When the Interpurge Period expires, a new Trial for Ignition is started again for up to a maximum of two additional trials.
- After the third Trial for Ignition has failed to light the burner, the S9200U1000 proceeds to the Interpurge Period followed by the Soft Lockout, where it remains for the Auto Restart Delay before beginning another set of ignition sequences.
- The retry count is cleared if flame is sensed for longer than 10 seconds after exiting Trial for Ignition.

Ignition Recycle

When flame is established during Trial for Ignition, maintained for at least 10 seconds, and then lost:

- The gas valve is de-energized.
- The inducer remains energized during the Interpurge Period.
- A new Trial for Ignition is started when the Interpurge Period expires.
- A maximum of three recycles are allowed on a single call for heat before the control proceeds to Soft Lockout. The recycle count is not cleared until the current demand for heat is satisfied or the S9200U1000 has just exited Soft Lockout or the S9200U1000 is in run mode continuously for one hour.

Rollout Circuit Operation (during Heat cycle)

If the rollout circuit opens during a heating cycle:

- The gas valve is immediately de-energized.
- The inducer is energized.

- The circulator is energized at heat speed.
- An LED error code is flashed, which indicates the rollout circuit has opened. See Table 11 on page 20.
- An EnviraCOM™ alarm is active and sent on the bus. See Table 13 on page 22.
- Thermostat requests for heat are ignored.

The S9200U1000 remains in this state until the rollout circuit closes.

Once the rollout circuit has closed:

- The inducer is de-energized after the Postpurge Period.
- The circulator is de-energized after the selected heat off delay.
- The LED continues to flash the rollout switch error code.
- Thermostat requests for heat are still ignored.

The S9200U1000 remains in this state until power is cycled, at which time the S9200U1000 resumes normal operation.

Limit Switch Circuit Operation (during Heat cycle)

If the limit circuit opens during a heating cycle:

- The gas valve is immediately de-energized and the inducer is de-energized after the Postpurge Period.
- The LED flashes an error code, indicating the limit circuit is open. See Table 11 on page 20.
- An EnviraCOM™ alarm is active and sent on the bus. See Table 13 on page 22.
- The circulator is immediately energized or remains energized at the heat speed.
- If the limit switch opens during the Trial for Ignition period, the trial is treated as a failed one (next trial is retry).
- If the limit switch opens in run mode, the sequence is treated as a failed one (next trial is recycle).

The S9200U1000 remains in this state until the limit circuit closes. Once the limit circuit closes:

- If the limit circuit was open for less than three minutes, a new ignition sequence is started and the circulator will remain energized for the selected fan off delay. If the burner is lit before expiration of the selected fan off delay, the fan off timing is stopped and the circulator remains energized.
- If the limit circuit was open for longer than three minutes, the circulator will remain energized at heat speed for the selected heat fan off delay, and the S9200U1000 will proceed to Soft Lockout, where it will remain for the Auto Restart Delay or until a thermostat reset is detected.

Pressure Switch Operation (during Heat cycle)

- If a call for heat is initiated and the pressure switch is closed before the ignition sequence has begun, the S9200U1000 will wait five seconds and flash an LED error code, which indicates the pressure switch is stuck closed. An EnviraCOM™ alarm is active and sent on the bus (see Table 13 on page 22). As soon as the pressure switch opens the error code clears and the ignition sequence proceeds as normal.
- If the ignition sequence has begun and the pressure switch fails to close within 150 seconds of energizing the inducer, the S9200U1000 de-energizes the inducer, starts flashing the

“Pressure Switch Failed Open” error code and returns to Idle Mode for five minutes before beginning the ignition sequence again (see Table 11 on page 20). An EnviraCOM™ alarm is active and sent on the bus (see Table 13 on page 22).

- This process continues indefinitely and an error code indicating a failed pressure switch flashes until the pressure switch finally closes or the call for heat ends.
- If the pressure switch opens during Prepurge or Igniter Warm-up, the S9200U1000 will de-energize the igniter and leave the inducer energized for a maximum of 60 seconds to try and re-close the switch. If the switch closes, the ignition cycle will resume from the beginning of Prepurge again. If the switch does not re-close, the S9200U1000 behaves as if the pressure switch had not closed after the inducer turned on.
- If the pressure switch opens for longer than two seconds during Trial for Ignition or opens for longer than 50 milliseconds during normal fire operation and flame is lost, the S9200U1000 proceeds to Interpurge before attempting the ignition sequence again.
An error code indicating the pressure switch failed open flashes until the burner is lit again or the heat demand is removed (see Table 11 on page 20). An EnviraCOM™ alarm is active and sent on the bus (see Table 13 on page 22.)
- If the pressure switch opens for longer than two seconds during Interpurge, the S9200U1000 proceeds to the “Wait for Pressure Switch to Close” state.

Hot Surface Igniter (HSI) Control

The Hot Surface Igniter is directly powered by line voltage input. The HSI warm-up time is shorter for the first ignition trial when using the 17/27 second warm-up time setting and longer for subsequent trials. See Table 9 on page 12.

Normal Cooling Mode

A call for cooling is signaled by:

- The shorting of R/2 to Y.
- The shorting of R/2 to Y and G simultaneously.
- An EnviraCOM™ cool demand of any stage.

Refer to Fig. 10 on page 18 for the control sequence diagram.

Fan Mode

In fan mode operation:

- If the S9200U1000 is not currently servicing another circulator request, the circulator energizes at the heat speed when R/2 is shorted to G and de-energizes when the request is removed. G functionality can also be received as an EnviraCOM™ message.
- If the S9200U1000 is servicing a fan request and a call for cool occurs, the circulator switches to the cool speed after the Cool Fan On Delay.
- If the S9200U1000 is servicing a fan request and a call for heat occurs, the circulator remains energized at the heat speed.

Refer to Fig. 11 on page 18 for the control sequence diagram.

Humidity Control

The line voltage humidifier output energizes anytime the inducer energizes.

Electronic Air Cleaner

The line voltage EAC output energizes anytime the circulator is energized.

II. CHECK SAFETY SHUTOFF OPERATION

1. Shut off the gas supply at the manual gas valve ahead of the appliance.
2. Set the thermostat to call for heat. System should operate as indicated in Fig. 9 on page 17.
3. Following lockout, open the manual gas valve and make sure no gas is flowing to the burner.

Error Conditions

The following section lists the S9200U1000 operating sequence for the stated error conditions.

Main Valve Sensing

The S9200U1000 monitors the valve output during the following conditions:

- Idle Mode
- Non-fault related states of Ignition sequence
- States related to the pressure switch fault
- When limit switch is open and inducer is no longer running, up to 180 seconds following the limit switch opening

In other conditions/states, main valve feedback is not monitored.

MAIN VALVE FEEDBACK PROCESSING

If the inducer is off or on while the pressure switch is still open, and voltage is detected on the valve for longer than the fault debouncing time (miswire):

- All outputs are turned off except for the inducer, which is kept energized.
- The circulator energizes at the heat speed.
- If a call for cool occurs, the control energizes the circulator at cool speed after the appropriate delay.
- An error code flashes indicating there is a hardware malfunction. See Table 11 on page 20.
- An EnviraCOM™ alarm is active and sent on the bus. See Table 13 on page 22.

If voltage is no longer detected on the valve for more than the fault debouncing time:

- If the number of detected gas valve welded/ miswire conditions have not reached 5 (since last power-up), the S9200U1000 proceeds to Soft Lockout. The S9200U1000 remains in Soft Lockout for the Auto Restart Delay.
- If the number of detected gas valve welded/ miswire conditions have reached 5 (since last power-up), the S9200U1000 enters Hard Lockout, where it remains until power reset. An EnviraCOM™ alarm indicating that manual reset is needed is active and sent on the bus. See Table 13 on page 22.

If the inducer is energized or the pressure switch is closed and the inducer is not energized (pressure switch is stuck closed) and the main valve relay contacts are sensed closed even though the relay is not energized (welded contacts):

- An error code flashes indicating there is a hardware malfunction. See Table 11 on page 20.
- An EnviraCOM™ alarm is active and sent on the bus. See Table 13 on page 22.
- The inducer immediately switches off in an attempt to open the pressure switch. If, after 5 seconds, flame is sensed or voltage is still sensed on the main valve, the S9200U1000 energizes the inducer and circulator on heat speed.

If flame is not sensed and voltage on the main valve is no longer detected:

- The S9200U1000 proceeds to Soft Lockout if the number of detected gas valve welded/ miss-wire conditions have not reached 5 (since last power-up). The S9200U1000 remains in Soft Lockout for the Auto Restart Delay period. Otherwise, the S9200U1000 will enter Hard Lockout where it will remain until power is reset.

If voltage is not detected on the valve for longer than the fault debouncing time during a period when the valve is to be energized (contacts failed to make):

- the S9200U1000 proceeds as if flame is not sensed. If Soft Lockout is entered due to this condition:
 - An error code flashes indicating failed hardware. See Table 11 on page 20.
 - An EnviraCOM™ alarm is active and sent on the bus. See Table 13 on page 22.

Flame Out of Sequence

The S9200U1000 does not take action on flame sensed in Idle Mode when there is no call for heat present.

If the S9200U1000 is servicing a call for heat and flame is sensed when it is not expected to be present, the ignition and fan sequences are not allowed to progress and the S9200U1000 stays in its current state. The exception is Igniter Warm-up, where the S9200U1000 proceeds to Prepurge.

If the sensed flame goes away before the False Flame Recognition Period, the ignition sequence proceeds as normal.

If however the sensed flame lasts longer than the False Flame Recognition Period:

- The igniter de-energizes, the inducer energizes, and the circulator energizes at heat speed.
- An error code flashes indicating flame is sensed out of sequence. See Table 11 on page 20.
- An EnviraCOM™ alarm is active and sent on the bus. See Table 13 on page 22.
- When the sensed flame goes away, the S9200U1000 proceeds to Postpurge, followed by Idle Mode at which time the error code is cleared.

Line Voltage and Earth Ground Sensing

The line voltage circuitry is monitored for reversed polarity in Idle Mode in all non-fault related states except from HSI warm-up.

- If reversed polarity is detected for longer than the fault debouncing time, all requests for heat are ignored.
- An error code flashes indicating line voltage polarity is reversed. See Table 11 on page 20.
- An EnviraCOM™ alarm is active and sent on the bus. See Table 13 on page 22.
- Fan and cool requests process as normal.

Line voltage sensing requires a 120 Vac (nominal) earth ground referenced supply with an electrical connection between the transformer secondary and earth ground. Typical installations connect one side of the secondary to the appliance chassis and the appliance chassis to earth ground.

- If either the secondary to chassis connection, or the chassis to earth ground connection are missing or providing poor electrical contact, the S9200U1000 proceeds to "Self Check Lockout."
- An error code flashes indicating there is no line voltage ground present. See Table 11 on page 20.
- An EnviraCOM™ alarm is active and sent on the bus. See Table 13 on page 22.
- Fan and cool requests process as normal.

These two faults (Line Voltage and Earth Ground Sensing) are combined into one detectable fault.

Weak Flame Sensing

The S9200U1000 flashes an error code if, after a successful Trial for Ignition and while operating in normal fire mode, the S9200U1000 senses a weak flame signal for longer than five seconds.

- When the flame is weak, the Flame (amber) LED flashes indicating there is a poor flame signal. See Table 11 on page 20.
- An EnviraCOM™ alarm is active and sent on the bus. See Table 13 on page 22.

To clear the error code, a strong flame must be sensed for longer than five seconds or the heat demand must be removed.

Low 24 Vac Input Sensing

If low voltage on 24 Vac input is detected, the S9200U1000 turns off all relays, ignore all requests, and wait until the voltage recovers.

- The S9200U1000 flashes an error code indicating low 24 Vac. See Table 11 on page 20.
- An EnviraCOM™ alarm is active and sent on the bus. See Table 13 on page 22. The alarm may not be received due to low line voltage, but will be stored in the alarm history.

When the voltage recovers, the S9200U1000 returns to normal operation five seconds after the fault clears.

Bad Fuse

Once a bad fuse is detected, the S9200U1000 behaves in following manner:

- Thermostat requests that are in progress become inactive and are finished as if they were removed.
- All new thermostat requests are ignored.
- The S9200U1000 flashes an error code indicating a bad fuse. See Table 11 on page 20.
- An EnviraCOM™ alarm is active and sent on the bus. See Table 13 on page 22. The alarm may not be received due to low line voltage, but will be stored in the alarm history.

Once a good fuse is detected, the S9200U1000 returns back to normal operation through a micro reset.

Soft Lockout

Soft Lockout is intended to prevent initiation of a new heating cycle for a certain time after the fault related to the heating sequence occurs. Behavior in Soft Lockout is defined as follows:

- Thermostat heat requests are ignored.
- Thermostat cool requests are served as normal.
- Fan requests are served as normal.
- The S9200U1000 flashes a fault code identifying the fault that caused transition to the Soft Lockout. See Table 11 on page 20.
- An EnviraCOM™ alarm indicating the fault is active and sent on the bus. See Table 13 on page 22.

The S9200U1000 is reset from Soft Lockout by any one of the following three ways:

- Cycling power: Removing power for longer than 10 seconds.
- Thermostat Reset: Removing the call for heat for longer than five seconds but less than 20 seconds.
- Auto Restart: The S9200U1000 automatically exits Soft Lockout after the Auto Restart Delay expires if the cause of the Soft Lockout has cleared.

Hard Lockout

Hard Lockout is intended to prevent initiation of a new heating cycle after a serious fault related to heating (e.g. rollout switch opening). Behavior in Hard Lockout is defined as follows:

- Thermostat heat requests are ignored.
- Thermostat cool requests are served as normal.
- Fan requests are served as normal.
- The S9200U1000 flashes a fault code identifying the fault that caused transition to the Hard Lockout. See Table 11 on page 20.
- An EnviraCOM™ alarm indicating that manual reset is needed is active and sent on the bus. See Table 13 on page 22.

The S9200U1000 remains in this state until manual power reset.

Self Check Lockout

Self Check Lockout is intended to prevent initiation of a new heating cycle after the self check mechanism has detected a hardware fault. The S9200U1000 functionality during a Self Check Lockout is defined as follows:

- Thermostat heat requests are ignored.
- Thermostat cool requests are served as normal.
- Fan requests are served as normal.
- The S9200U1000 flashes a fault code identifying the fault that caused transition to the Self Check Lockout. See Table 11 on page 20.
- An EnviraCOM™ alarm indicating the fault is active and sent on the bus. See Table 13 on page 22.
- The S9200U1000 remains in this state until the fault disappears.

For the S9200U1000 to return back to normal operation, no fault must be present for the Self Check Lockout Return Delay, which is five minutes.

Operating Sequences

Fig. 9–11 beginning on page 17 describe the operations of the S9200U1000 control.

1. CALL FOR HEAT

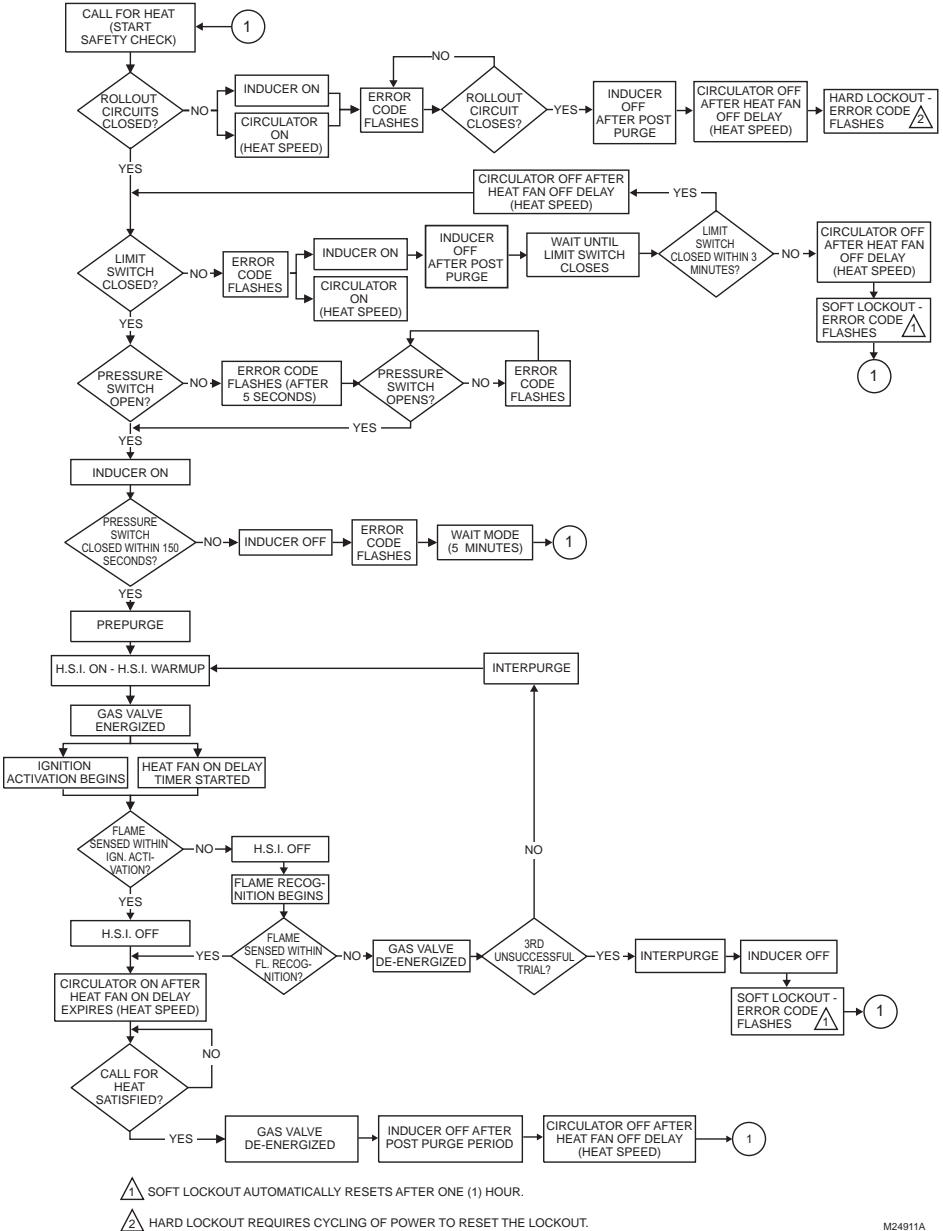
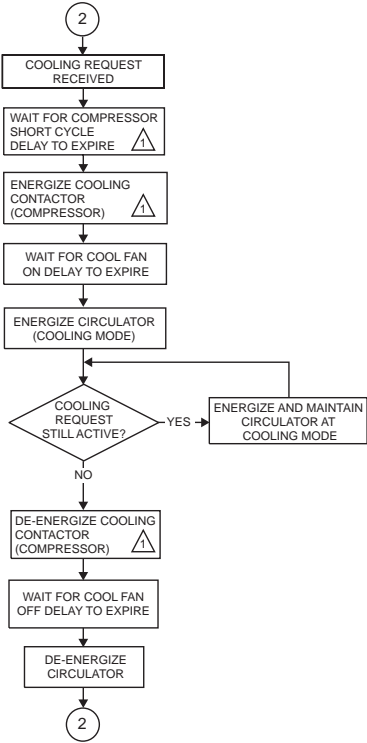

Fig. 9. S9200U1000 sequence - Call for Heat cycle.

M24911A

2. CALL FOR COOLING



⚠ THE OPERATION IN THE BLOCK IS SKIPPED WHEN A SYSTEM WITH A CONVENTIONAL THERMOSTAT IS USED. THE OPERATION IS PERFORMED IN SYSTEMS WITH AN ENVIRACOM™ THERMOSTAT ONLY.

M24912A

Fig. 10. S9200U1000 sequence - Cooling Mode cycle.

3. CALL FOR FAN

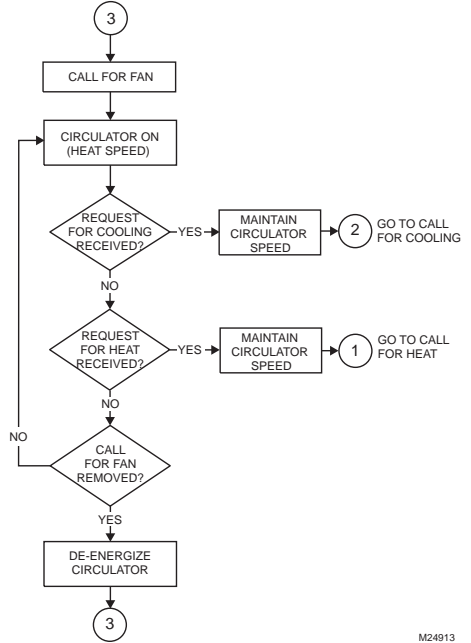

M24913

Fig. 11. S9200U1000 sequence - Fan Mode cycle.

TROUBLESHOOTING

WARNING

Fire, Explosion, or Electrical Shock Hazard.
Can cause severe injury, property damage, or death.
 Do not attempt to modify the physical or electrical characteristics of this device in any way. Replace it if troubleshooting indicates a malfunction.

IMPORTANT

1. *The status codes outlined in Table 10, Table 11, and Table 12 beginning on page 20 are a general guide. Follow appliance manufacturer service instructions when available.*
2. *Take all meter readings within the Trial for Ignition period. After the ignition period ends, before continuing, reset the system by turning down the thermostat for at least five seconds but for less than 20 seconds.*
3. *If any component does not function properly, make sure it is correctly installed and wired before replacing it.*
4. *Static discharge can damage the integrated furnace control. Touch an appliance metal surface to discharge static electricity before touching the furnace control.*
5. *The S9200U1000 cannot be repaired. If it malfunctions, replace it.*
6. *Only trained, experienced service technicians should service integrated furnace control systems. Perform the checkout steps listed in "Checkout" on page 13 before beginning any troubleshooting procedure. After troubleshooting, check out the system again to be sure it is operating normally.*

LED Indicators

The S9200U1000 has three LEDs. The three LEDs from left to right as shown in Fig. 4 on page 9 are:

- **Flame – Amber LED**
 The Amber LED Indicates flame status such as weak or no flame. The Flame status codes are mapped in Table 10 on page 20.
- **STATUS – Red LED**
 The Red LED indicates general system status, such as the presence of a call for heat and various error codes. The Status LED Status codes are mapped in Table 11 on page 20.
- **E-COM – Green LED**
 This Green LED indicates EnviraCOM™ transmission is underway. The LED is directly linked to communication on the EnviraCOM™ bus. The E-COM LED Status codes are mapped in Table 12 on page 21.
 - A typical transmitted message appears as a rapid flashing of the green LED.
 - A typical received message appears as single blink, indicating the S9200U1000 has acknowledged the message.

NOTE: The E-COM LED is active even if a conventional thermostat is controlling the appliance.

Flash Code Descriptions

The LEDs flash codes at various intervals. Each pulse type indicates a specific functionality/ message type.

- **Periodic Blink (Normal):** 0.5 second on, 0.5 second off.
- **Pulse:** A 0.25 second flash followed by 3.75 seconds of off time.
- **Heartbeat:** Constant 0.5 second bright, 0.5 second dim cycles.
- **Standard LED Fault Pattern (Single X Flash):** LED flashes X times at 2Hz, then off for 3 seconds.
- **Advanced LED Fault Pattern (X + Y Flash):** LED flashes X times at 2Hz, remains off for one second, flashes Y times at 2Hz, remains off for three seconds, and then repeats.

Table 10. Flame Status Codes (Amber LED).

Flash Code ^a	Amber LED Status Code and Error Description	Check / Repair
OFF	Control powered - No flame	Not Applicable (normal operation)
Heartbeat	Control powered - Call for heat - Flame present	Not Applicable (normal operation)
Periodic Blink ^b	Call for heat - Low flame current	Check: Flame rod for contamination or loose wiring; low gas pressure.
Heartbeat	Call for heat - Flame sense out of sequence - Flame still present	Check/Repair: Flame at burners, if present replace gas valve.
OFF	All other conditions	Not Applicable

^a Flash Code Descriptions:

- Pulse: A 0.25 second flash followed by 3.75 seconds of off time.
- Heartbeat: Constant 0.5 second bright 0.5 second dim cycles.
- Periodic Blink: 0.5 second on, 0.5 second off. During local history recall, this fault is flashed as a 1 + 2 pattern.

^b During local history recall, this fault is flashed as a 1 + 2 pattern.

Table 11. Control Status Codes (Red LED).

Flash Code ^a	Red LED Status Code and Error Description	Check / Repair
Pulse	Control powered (Standby; No Call for Heat)	Not Applicable
Heartbeat	Call for Heat - Normal operation	Not Applicable (normal operation)
Pressure Switch Codes		
2	Pressure Switch failed Open	Check: If inducer is running, inducer could be broken or disconnected, or inducer relay K4 may have failed. Check/Repair: Low line voltage; Pressure switch wiring loose; hose disconnected or leaking; water in hose; venting blocked or obstructed.
3	Pressure Switch failed Closed	Check: If inducer is off, inducer relay (K4) could be welded. Check/Repair: Terminal wiring (shorted); pressure switch contacts (closed when should be open); pressure switch hoses have water build-up or obstruction.
4	Pressure Switch opened during Trial For Ignition or Run Mode	Check: See if inducer is running. Check/Repair: Restricted venting; low input voltage; water in horizontal vent length.
Limit Code		
5	Limit switch open	Check: Wiring; restricted airflow through heat exchanger; clogged filters; slow circulator fan speed. Repair: Remove restrictions. Increase airflow through furnace (increase motor speed, open more ducts, add more returns).
Flame Code		
6	Unexpected flame - Waiting for flame to be off after the 20 second delay	Check/Repair: Gas valve leakage.
Soft Lockout Codes		
2 + 1	Soft Lockout - Exceed maximum number of retries	Check/Repair: Gas supply (pressure, supply, shut-off valves, gas valve); ignition (HSI element not properly positioned and glowing); flame sensing (lead-wire broken or grounded, flame rod not properly positioned, or flame rod contamination); low line voltage.
2 + 3	Soft Lockout - Exceeded maximum number of recycles or retries where the last recycle/retry was due to the pressure switch opening	Check/Repair: Pressure switch wiring; slow inducer; restricted, excessive, or obstructed venting; unstable line voltage.
2 + 4	Soft Lockout - Exceeded maximum number of recycles where the last recycle was due to a flame failure	Check/Repair: Gas supply; flame sensor wiring.
2 + 5	Soft Lockout - Exceeded maximum number of recycles where the last recycle was due to the limit circuit opening or the limit remained open longer than three minutes	Check: Wiring; restricted airflow through heat exchanger; clogged filters; slow circulator fan speed. Repair: Remove restrictions. Increase airflow through furnace (increase motor speed, open more ducts, add more returns).
2 + 6	Soft Lockout - Gas Valve Failed to Make	Check/Repair: Gas valve, Gas valve wiring. Replace S9200U1000 if problem persists.

Table 11. Control Status Codes (Red LED). (Continued)

Flash Code ^a	Red LED Status Code and Error Description	Check / Repair
Other Codes		
3 + 1	Low 24V (Control restarts if the error recovers)	Check/Repair: Low voltage transformer and circuit. Voltage should be nominally 24 Vac with 120 Vac on incoming line voltage. Verify low voltage under all thermostat request modes to insure there are no issues with other low voltage loads such as the outdoor unit 24 Vac contactor.
3 + 2	Bad Fuse	Check: Wiring (limit, rollout, pressure switch shorted to chassis; EnviraCOM™ bus); gas valve could be shorted. Turn off the power and replace the fuse with a fuse of the same type. Cycle power to appliance and run heating sequence. If this failure repeats, replace the control.
3 + 4	Gas valve error - Miswire or welded (Control restarts if the error recovers and it has not been detected five times yet)	Check/Repair: Gas valve wiring. Cycle power to appliance and run heating sequence. If this failure repeats, replace the control.
3 + 5	Control failed Self Check, internal error, or failed hardware (Control restarts if the error recovers.) This covers hardware errors like flame sense circuit faults, pin shorts, etc.	Cycle power to appliance and run heating sequence. If this failure repeats, replace the control.
3 + 6	Reversed Line Voltage Polarity or Poor Earth Ground (Control restarts if the error recovers within 5 minutes after the fault has cleared.)	Check: 1. Line voltage input wiring. Assure line voltage hot lead is attached to L1. 2. Ground wire from control to appliance and appliance earth ground. 3. Voltage between line volt Neutral and appliance chassis. If over 10 volts, repair the wiring or move the furnace to another circuit with a good earth ground. Repair: Reverse line voltage inputs if line volt hot lead is not attached to the L1 input.
Hard Lockout Codes		
4 + 1	Hard Lockout - Rollout circuit open or previously opened.	Check/Repair: Flue restrictions; heat exchanger restricted Check burner. Check Rollout Switch including switch cables. Reset rollout if necessary. Do not operate until repairs are made. Cycle power to appliance and run heating sequence. If this failure repeats, replace the control.
4 + 2	Hard Lockout - Gas valve welded relay detected for five times	Check/Repair: Gas valve wiring. Cycle power to appliance and run heating sequence. If this failure repeats, replace the control.

^a Flash Code Descriptions:

- Pulse: A 0.25 second flash followed by 3.75 seconds of off time.
- Heartbeat: Constant 0.5 second bright, 0.5 second dim cycles.
- During start-up the STATUS LED blinks fast for approximately 2 seconds. If the S9200U1000 continues blinking fast (8 pulses/second), the control has failed and must be replaced.
- Standard LED Fault Pattern (Single X Flash): LED flashes X times at 2Hz, then off for 3 seconds.
- Advanced LED Fault Pattern (X + Y Flash): LED flashes X times at 2Hz, remains off for one second, flashes Y times at 2Hz, remains off for three seconds, and then repeats.

Table 12. E-COM Status Codes (Green LED).

Flash Code	Green LED Status Code and Description ^a	Check / Repair
Rapid Flashing	Bus Activity - Message being transmitted	Not Applicable (normal operation)
Single Blink	Bus Activity - Received message acknowledgment	Not Applicable (normal operation)
Off	No Bus Activity	Check/Repair: Disconnect the S9200U1000 from the external bus wiring, cycle power and check the bus activity. If there is activity, repair external bus wiring/devices before reconnecting the S9200U1000. If there is still no activity, replace the control.

^a This LED is active even if a conventional thermostat is controlling the appliance.

Status Codes History

The S9200U1000 stores the ten (10) most recent error codes. These codes can be recalled for viewing during troubleshooting and cleared if necessary.

Recalling the Status Code History

You may perform the following procedure multiple times to confirm that you have viewed all the currently stored error codes.

To recall the error code history and display it via the red status LED, perform the following:

1. Jumper the thermostat screw-terminal R/2 to screw-terminal D/1.
 - Within 0.5 seconds, the red status LED stops normal operation and turns on solid to indicate that the jumper is sensed.
2. Keep the thermostat screw-terminals R/2 to D/1 jumpered.
 - After a 5 second time-out, the red status LED turns off, indicating that error code recall is pending.
3. Within 10 seconds of the red status LED turning off, remove the jumper from thermostat screw-terminals R/2 to D/1.
 - This activates the error code recall.

IMPORTANT

If the R/2 to D/1 terminal jumper is not removed within the 10 seconds, the history is erased.

4. Each saved error code blinks once on the red status LED, starting with the most recently stored error code.

NOTE: If there are no error codes to display, the red status LED immediately returns to normal operation.

5. After last error code displays, the red status LED returns to normal operation.

Clearing the Status Code History

This procedure erases the entire history of fault (error) codes.

IMPORTANT

Once this procedure is performed, it cannot be undone.

To clear the current error code history, perform the following:

1. Jumper the thermostat screw-terminal R/2 to terminal D/1.
 - Within 0.5 seconds the red status LED stops normal operation and turns on solid to indicate that the jumper is sensed.
2. Keep the thermostat screw-terminal R/2 to D/1 jumpered.
 - After a 5 second time-out, the red status LED turns off.
 - After a 10 second time-out, the red status LED turns on solid to indicate that the error history is being cleared.
3. When the error history is cleared, the red status LED returns to normal operation.
4. Remove the thermostat screw-terminal R/2 to terminal D/1 jumper.

EnviraCOM™ Communication

EnviraCOM™ communication is a standard feature on the S9200U1000. EnviraCOM™ can be used to control system operation by way of an EnviraCOM™ enabled thermostat and perform advanced diagnostics when connected to EnviraCOM™ enabled diagnostic tools such as the web based EnviraLNK® remote diagnostics application, the OnWatch QuickLook™ 72 and the W8735D Telephone Access Module (TAM). In addition to alarms, key information such as state and flame current can be sent over the EnviraCOM™ bus. See Table 13.

Table 13. S9200U1000 EnviraCOM™ Alarms.

Alarm Description	Alarm Number	Comment
This device has no alarms	0	Not Applicable
Pressure switch failed to close in the ignition sequence	1	Display/Diagnostics
Pressure switch failed to open in the ignition sequence	3	Display/Diagnostics
Flame current caution level while running	4	Display/Diagnostics
Soft lockout due to flame current	5	Display/Diagnostics
The maximum number of flame loss incidents has been exceeded	22	Display/Diagnostics
Limit switch open	26	Display/Diagnostics
Flame detected out of sequence	34	Display/Diagnostics
Soft Lockout due to recycle; last recycle was from pressure switch open	85	Display/Diagnostics
Soft Lockout due to recycle; last recycle was from limit switch open	86	Display/Diagnostics
The pressure switch opened in run or trial for more than the allowable time	98	Display/Diagnostics
Gas valve failed to energize	17	Display/Diagnostics/EnviraLNK®/TAM
Electronics down	18	Display/Diagnostics/EnviraLNK®/TAM
Reversed line polarity	33	Display/Diagnostics/EnviraLNK®/TAM
A manual reset is required due to Rollout Limit	87	Display/Diagnostics/EnviraLNK®/TAM

Table 13. S9200U1000 EnviraCOM™ Alarms. (Continued)

Alarm Description	Alarm Number	Comment
Earth ground problem	88	Display/Diagnostics/EnviraLNK®/TAM
A bad fuse has been detected (NOTE: This alarm is stored in the Status Code History)	92	Display/Diagnostics/EnviraLNK®/TAM
The gas valve relay was sensed as closed when it should be open	100	Display/Diagnostics/EnviraLNK®/TAM
A manual reset is required due to gas valve welded condition being detected more times than allowed maximum	124	Display/Diagnostics/EnviraLNK®/TAM
Low voltage is detected on 24 Vac input	125	Display/Diagnostics/EnviraLNK®/TAM

Test Mode

The S9200U1000 is equipped with a Test Mode feature which allows the control to test and verify several critical parameters. During Test Mode, the S9200U1000 alters the selected Safety Timings as described in Table 14.

Table 14. Test Mode Parameters.

Test Mode Parameter	Modified Timing
Pre-Purge	5 seconds
HSI Warm-up	17 seconds
Ignition Activation	3 seconds
Flame Recognition	1 second
Trial for Ignition	4 seconds
Heat Fan ON Delay	15 seconds
Heat Fan OFF Delay	0 seconds
Post-Purge	5 seconds
Cool Fan ON Delay	2 seconds
Cool Fan OFF Delay	0 seconds

Test Mode can be accessed several ways:

- Thermostat inputs:
 - Apply a Y + G request within 3 seconds after power-up for 2 seconds.
 - Next, remove the Y + G request and apply W request within 10 seconds.
- EnviraCOM™ command
- The G signal enables the circulator in Test Mode. If a G request is present, the circulator is controlled as required by the heating or cooling sequence. If the G request is removed, the circulator turns off during the heating or cooling sequence. If there is no other thermostat request present, a G request causes the circulator to be energized. The circulator energizes during a heating cycle if the limit switch opens, regardless of the G signal.

If there is a failure during Test Mode:

- An error code flashes indicating the failure. See Table 11 on page 20.
- An EnviraCOM™ alarm is active and sent on the bus. See Table 13 on page 22.

Test Mode is exited after any of the following conditions:

- Three minutes of operation
- Receipt of an EnviraCOM™ command instructing the S9200U1000 to exit Test Mode
- The cycling of power

QuickLook™ 72 is a trademark of OnWatch Electronics Inc.

EnviraCom™ is a trademark of Honeywell.

EnviraLNK® is a registered trademark of Honeywell.

Automation and Control Solutions

Honeywell International Inc.
1985 Douglas Drive North
Golden Valley, MN 55422
customer.honeywell.com

Honeywell Limited-Honeywell Limitée
35 Dynamic Drive
Toronto, Ontario M1V 4Z9

Honeywell

