

V4043, V4044 Valves; V8043, V8044 Zone Valves

INSTALLATION INSTRUCTIONS

APPLICATION

These valves consist of an actuator motor and valve assembly for controlling the flow of hot and/or cold water. The V4043 and V8043 provide two-position, straight-through control of supply water. The V4044 and V8044 provide two-position, diverting control of supply water. The valves are designed for use with fan coil and other units requiring quiet, compact water valves. The V8043E and F also control supply water for baseboard radiators and convectors. The V4043E and V8043J provide straight-through control of steam only. Models are available with 125 or 300 psi operating pressure.

INSTALLATION

When Installing this Product...

1. Read these instructions carefully. Failure to follow them could damage the product or cause a hazardous condition.
2. Check the ratings given in the instructions and on the product to make sure the product is suitable for your application.
3. Installer must be a trained, experienced service technician.
4. After installation is complete, check out product operation as provided in these instructions

CAUTION

1. Disconnect power supply before connecting wiring to prevent electrical shock of equipment damage.
2. Normally it is not necessary to remove the powerhead from the valve body during installation. If the valve must be disassembled, be certain that it is reassembled with the water

- flow in the direction of the arrow. Reversal of the powerhead will result in damage to the gear train.
3. On 24V systems, never jumper the valve coil terminals even temporarily. This may burn out the heat anticipator in the thermostat.

IMPORTANT

Use this valve in hydronic heating systems which do not contain dissolved oxygen in the system water. The dissolved oxygen, which is found in systems that have a frequent source of makeup water, causes the rubber plug inside the valve to deteriorate and eventually fail.

LOCATION

Install the valve in an area with adequate clearance to:

- Move the manual opening lever on the side of the powerhead.
- Remove the powerhead cover.
- Wire the powerhead.
- Replace the powerhead motor.

The valve location should be in an area where the temperature does not exceed the maximum valve operating temperature as shown in Fig. 1. The maximum valve operating temperature depends on the maximum ambient temperature at the valve location and the maximum fluid temperature. Using the graph in Fig. 1, the maximum valve operating temperature can be found as follows:

1. Measure ambient temperature at valve and locate this temperature on the ambient temperature scale on the graph.
2. Draw a line from this ambient temperature, parallel with the fluid temperature scale, to the maximum fluid temperature line.
3. Draw a line from this point down to the fluid temperature scale to find maximum operating temperature. (Note the example, shown by the dashed line in Fig. 1).



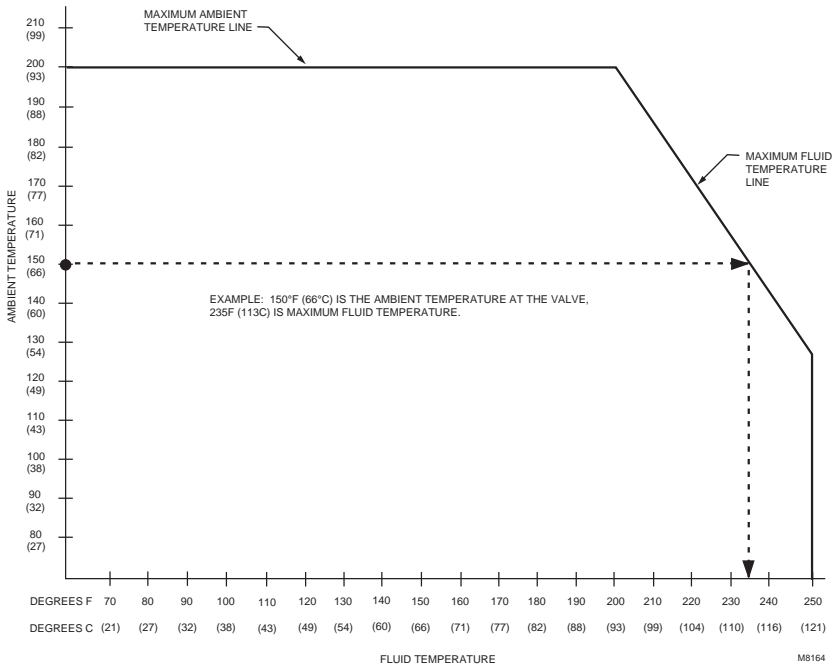

Fig. 1. Maximum temperature characteristics of valves.

MOUNTING

The valve can be mounted in any position on a vertical line. If the valve is mounted horizontally; the powerhead must be even with or above the center line of the piping. Make sure that enough room is provided above the powerhead to remove the cover for servicing.

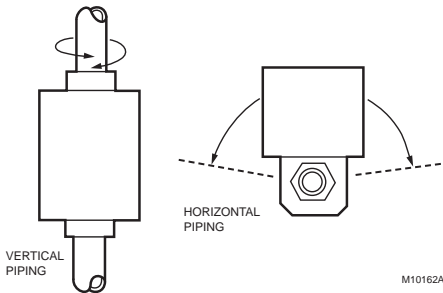

Fig. 2. Mounting positions.

Mount the valve directly in the tube or pipe. Make sure that the flow through the valve is in the direction indicated by the arrow stamped on the valve body.

On diverting valves, the three fittings or ports are labeled on the bottom of the valve body casting. See Fig. 3. Port AB is the inlet port and is open at all times. Port A is closed when the valve is de-energized; port B is open

when the valve is de-energized. Refer to the equipment manufacturer's instructions to determine which port (A or B) should be connected to the coil bypass.

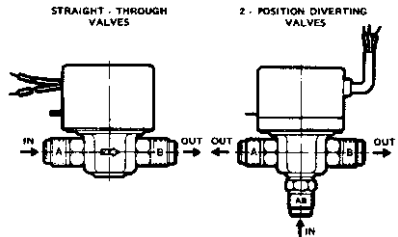

Fig. 3. Inlet and outlet ports on straight-through and diverting valves.

FLARE FITTING MODELS

Use new, properly reamed pipe, free from chips. The valve body is threaded for standard 5/8 in. OD copper, 45 degree SAE flare fitting nuts. These nuts are not furnished with the valve and must be obtained separately.

SWEAT COPPER MODELS

1. Use new, properly reamed pipe, free from dents or corrosion.
2. Place the valve onto the pipe. Set the manual opening lever to MAN. OPEN position before applying heat. This protects the plug inside the valve by removing it from the seat.

3. **IMPORTANT:** Take care not to burn the plastic portion of the composite adapter plate when soldering.
4. Sweat the joints, keeping the outer surface free from solder. DO NOT use silver solder because of the high melting temperature required.

To Install Replacement Powerhead

SYSTEMS WITH OLD STYLE VALVE BODIES (SERIES 1-5)

To install a replacement powerhead in a system with an old style body (series 1-5), the valve body must be converted to accept the new powerhead using Part No. 40003918 Conversion Kit. The kit includes a metal plate with a driveshaft and rubber plug, O-ring, and four screws.

IMPORTANT

Converting the valve body for use with the new powerhead does not require removal of the valve body from the pipeline. However, it is necessary to drain the water from the system before beginning the conversion.

1. Disconnect the power supply before connecting the wiring to prevent electrical shock or equipment damage.
2. Disconnect the leadwires to the powerhead at the terminal block or conduit connection. Remove the conduit or cable connector if fitted. Label each wire for rewiring later.
3. Drain the water from the system.
4. Remove the old powerhead from the valve body (Fig. 4)
 - a. Place the manual opening lever (normally closed models only) on the old powerhead in the MAN. OPEN position (see Fig. 4A).
 - b. Remove the cover (Fig. 4B).
 - c. With the cover off, remove the four screws securing the powerhead to the valve body.
 - d. Lift the powerhead off the valve body (Fig. 4C).
 - e. Remove the O-ring from the top of the valve body.

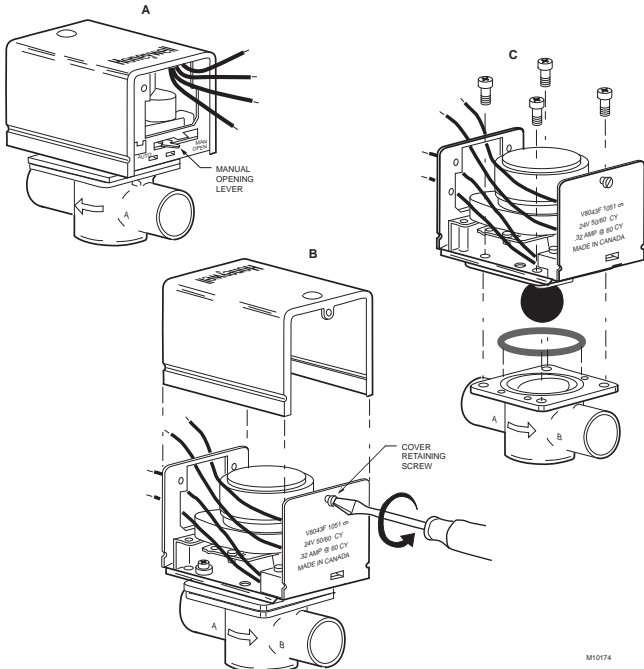

Fig. 4. Remove old powerhead from systems using old style valve bodies

5. Install 40003918 Conversion Kit (Fig. 5)
 - a. Insert the new O-ring in the valve body.
 - b. Place metal plate with the rubber plug on top of the valve body. Make sure the guide pins on the underside of the metal plate fit into the recesses on the valve body.
 - c. Secure the metal plate to the valve body with the four screws (two sets) provided. One set of screws has heads with recessed threads to

insert screws for mounting the new powerhead; insert this set into the larger screw openings. The other set has domed heads; insert this set into the smaller screw openings. Each set of screws must be inserted in opposite corners of the metal plate so the screws sit flat on the plate. Make sure the guide pins on the plate fit into the recesses on the valve body.

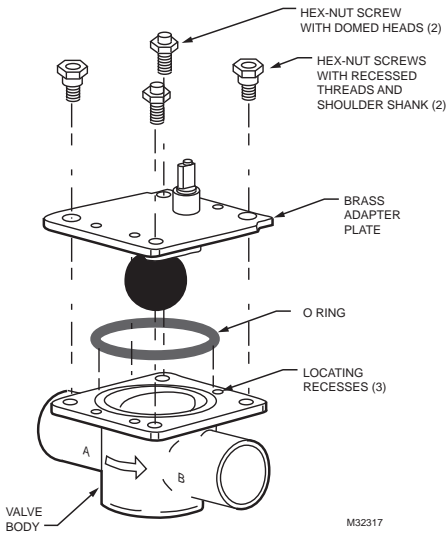

Fig. 5a. Install 40003918 conversion kit with brass adapter plate.

- c. Secure the powerhead to the valve body with the two screws provided.
 - d. If fitted, reconnect the conduit or cable. Reconnect the leadwires at the powerhead.
 - e. Replace the powerhead cover.
7. Turn on power.

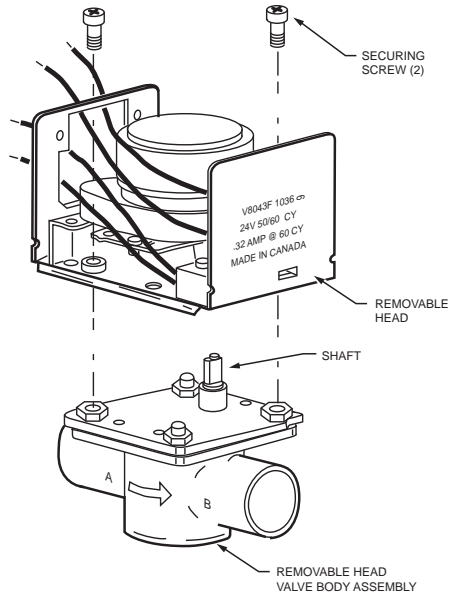

Fig. 6. Install new powerhead.

SYSTEMS WITH NEW STYLE VALVE BODIES (SERIES 6)

IMPORTANT

On a new style valve body that has been converted to accept the new powerhead, it is not necessary to drain the system if the valve body remains in the pipeline.

1. Disconnect the power supply before connecting the wiring to prevent electrical shock or equipment damage.
2. Disconnect the leadwires to the powerhead at the terminal block or conduit connection. Remove the conduit or cable connector, if fitted. Label each wire for rewiring later.
3. Remove the old powerhead (see Fig. 7):
 - a. Place the manual opening lever (normally closed models only) on the old powerhead in the MAN. OPEN position (Fig. 7A).
 - b. Remove the screw securing the cover to the powerhead (Fig. 7B).
 - c. Lift off the cover from the powerhead.
 - d. Remove the two screws securing the powerhead to the valve body (Fig. 6).
 - e. Lift the powerhead off the valve body.

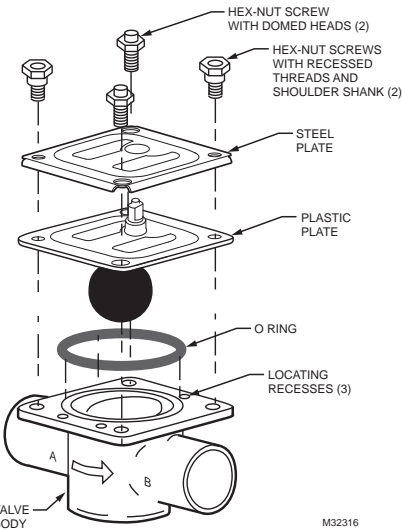

Fig. 5b. Install conversion kit with composite (steel & plastic) adapter plate.

6. Install new powerhead (see Fig. 6)
 - a. Place the manual opening lever (normally closed models only) on the new powerhead in the MAN. OPEN position.
 - b. Fit the powerhead onto the valve body, ensuring that the shaft seats correctly. The powerhead should be aligned so that the manual opening lever or slot for lever is at the port A end of the valve body.

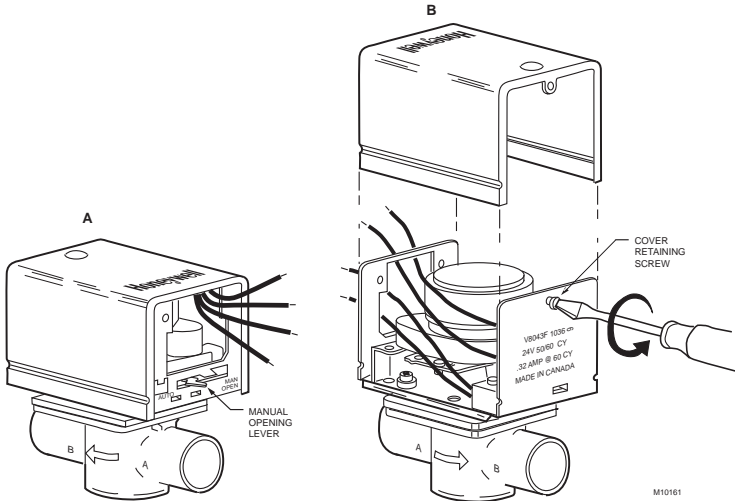

Fig. 7. Remove old powerhead cover from systems using new style valve bodies.

4. Install the new powerhead (see Fig. 6):
 - a. Place the manual opening lever (normally closed models only) on the new powerhead in the MAN. OPEN position.
 - b. Fit the powerhead onto the valve body, ensuring that the shaft seats correctly. The powerhead should be aligned so that the manual opening lever or slot for lever is at the port A end of the valve body.
 - c. Secure the powerhead to the valve body with the two screws provided.
 - d. If fitted, reconnect the conduit or cable. Reconnect the leadwires to the powerhead.
 - e. Replace the powerhead cover.
5. Turn on the power.

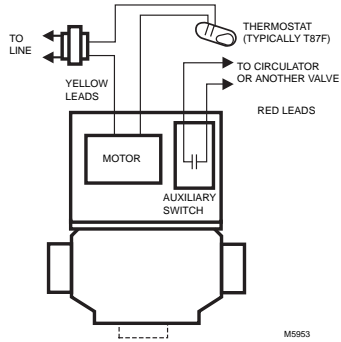

Fig. 8. Typical wiring for V8043E, V8044E.

WIRING

Disconnect the power supply before connecting wiring to prevent electrical shock or equipment damage.

All wiring must comply with local codes and ordinances. Connections to the individual valves are shown in Fig. 8-9. See Fig. 10 through 16 for typical hookups.

If replacing a Taco, Dole, Flair or White Rodgers 3-wire valve with a 2-wire V8043E or F, see Fig. 17 through 29. Check that the pressure rating of the new valve is appropriate for the application.

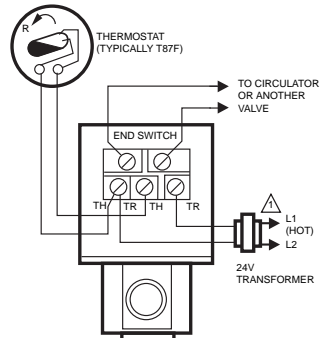

⚠ POWER SUPPLY. PROVIDE DISCONNECT MEANS AND OVERLOAD PROTECTION AS REQUIRED.

M5952

Fig. 9. Typical wiring for V8043F.

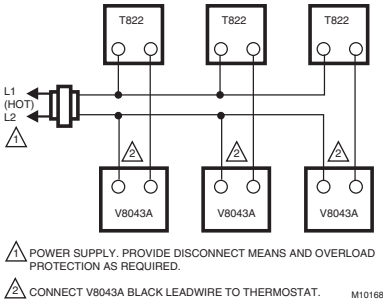

Fig. 10. T822 thermostat, V8043A valve hookup.

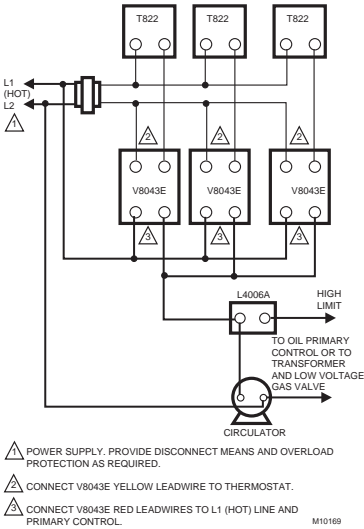

Fig. 11. T822, V8043E zone hookup for gas or oil. No domestic hot water.

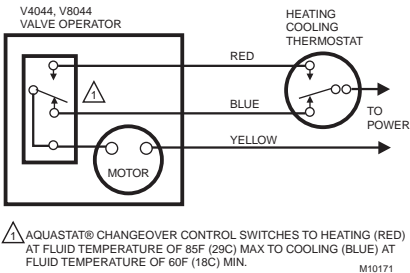

Fig. 12. Wiring diagram for V4044 and V8044 with Aquastat changeover control.

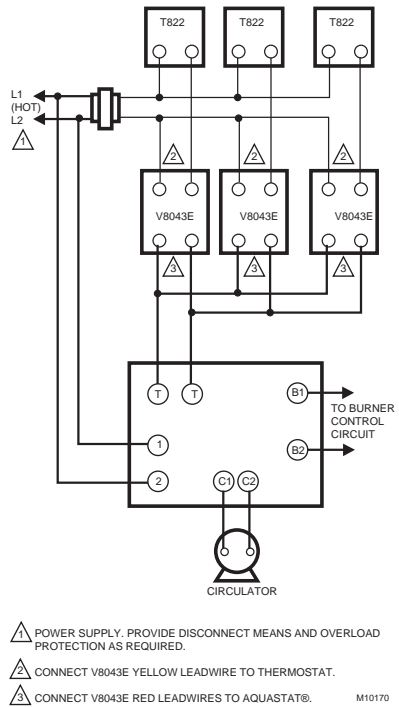

Fig. 13. T822, V8043E zone hookup for gas or oil with or without domestic hot water. Without domestic hot water, use L8148J for gas, L8148A for oil. With domestic hot water, use L8124E for gas, L8124A or C for oil.

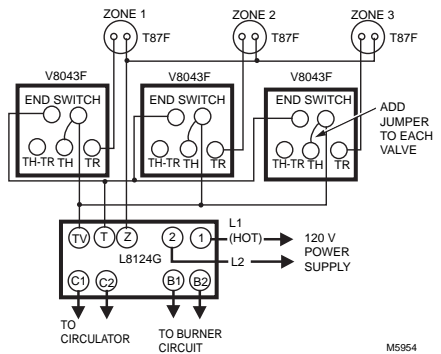

Fig. 14. Typical 3-zone system. Use an AT87A transformer to power up to 5 more zone valves.

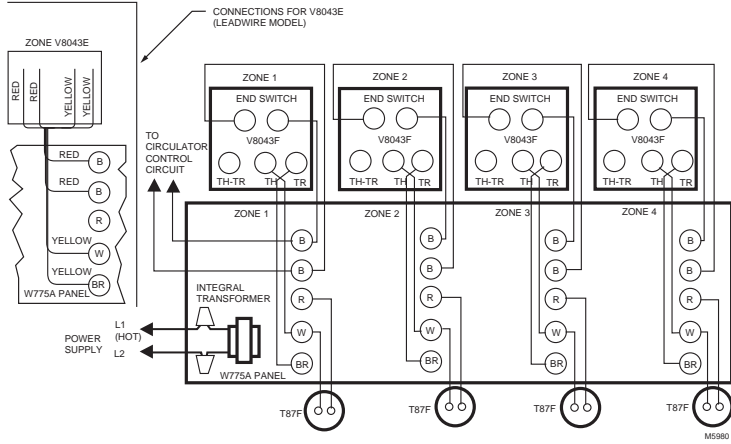

Fig. 15. Typical 4-zone system. Use an additional W775A to power up to 4 more zone valves.

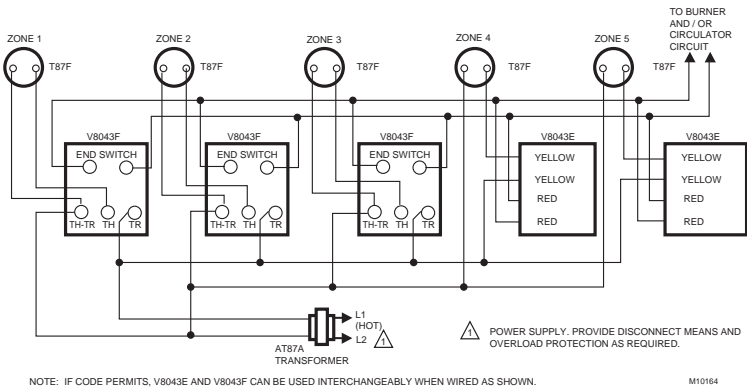

Fig. 16. Typical 5-zone system. Use an AT87A transformer to power up to 5 more zone valves.

How to Replace a Taco 3-Wire Valve with a Honeywell 2-Wire Valve

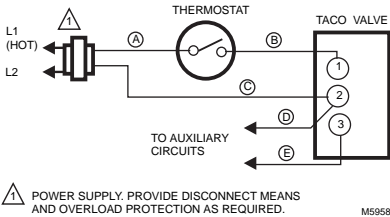

Fig. 17. Existing Taco System. (Wires are identified by letters for easy correspondence to wires on Figs. 18 & 19.)

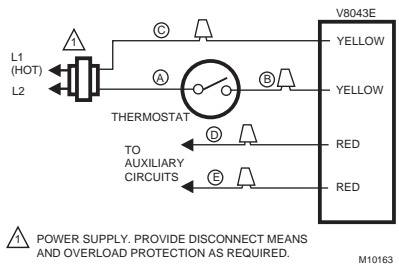
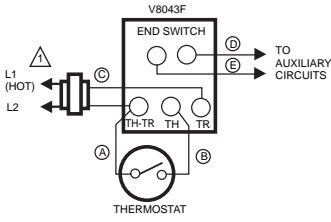

Fig. 18. Wiring a Honeywell V8043E to a Taco System. (Wires are identified by letters for easy correspondence to wires on Fig. 17.)



⚠ POWER SUPPLY. PROVIDE DISCONNECT MEANS AND OVERLOAD PROTECTION AS REQUIRED.

M5960

Fig. 19. Wiring a Honeywell V8043F to a Taco System (2 options). (Wires are identified by letters for easy correspondence to wires on Fig. 17.)

How to Replace a Dole 3-Wire Valve with a Honeywell 2-Wire Valve

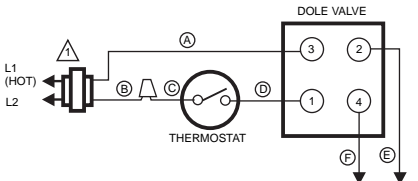

⚠ POWER SUPPLY. PROVIDE DISCONNECT MEANS AND OVERLOAD PROTECTION AS REQUIRED.

M5977

Fig. 20. Existing Dole System. (Wires are identified by letters for easy correspondence to wires on Figs. 21 & 22.)

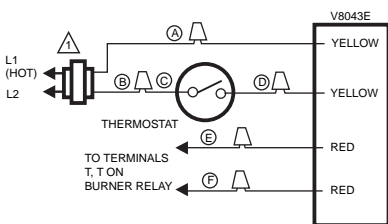

⚠ POWER SUPPLY. PROVIDE DISCONNECT MEANS AND OVERLOAD PROTECTION AS REQUIRED.

M5965

Fig. 21. Wiring a Honeywell V8043E to a Dole System. (Wires are identified by letters for easy correspondence to wires on Fig. 20.)

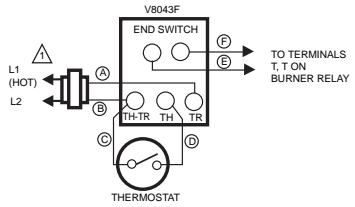

⚠ POWER SUPPLY. PROVIDE DISCONNECT MEANS AND OVERLOAD PROTECTION AS REQUIRED.

M5966

Fig. 22. Wiring a Honeywell V8043F to a Dole system (2 options). (Wires are identified by letters for easy correspondence to wires on Fig. 20.)

How to Replace a Flair 3-Wire Valve with a Honeywell 2-Wire Valve

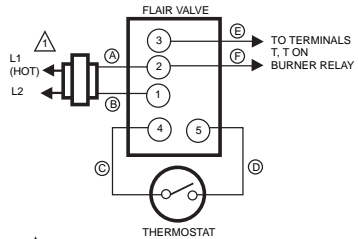

⚠ POWER SUPPLY. PROVIDE DISCONNECT MEANS AND OVERLOAD PROTECTION AS REQUIRED.

M5978

Fig. 23. Existing Flair System. (Wires are identified by letters for easy correspondence to wires on Figs. 23 & 24.)

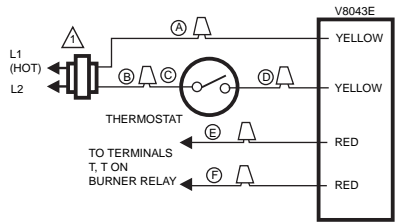

⚠ POWER SUPPLY. PROVIDE DISCONNECT MEANS AND OVERLOAD PROTECTION AS REQUIRED.

M5965

Fig. 24. Wiring a Honeywell V8043E to a Flair System. (Wires are identified by letters for easy correspondence to wires on Fig. 23.)

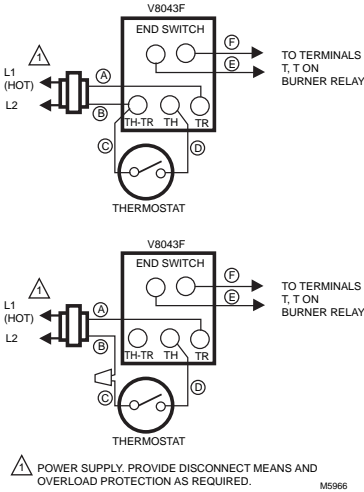

Fig. 25. Wiring a Honeywell V8043F to a Flair System (2 options). (Wires are identified by letters for easy correspondence to wires on Fig. 23.)

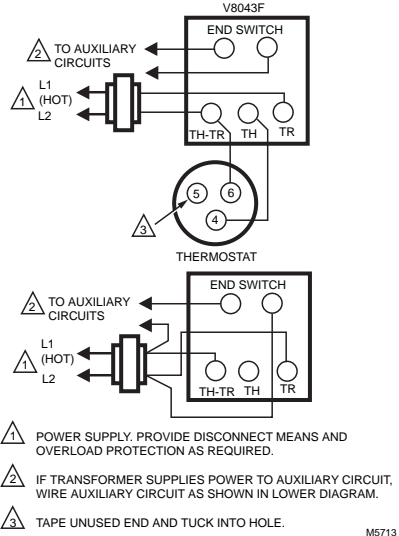

Fig. 28. Wiring a Honeywell V8043F to a White-Rodgers System (one option).

How to Replace a White-Rodgers 3-Wire Valve with a Honeywell 2-Wire Valve

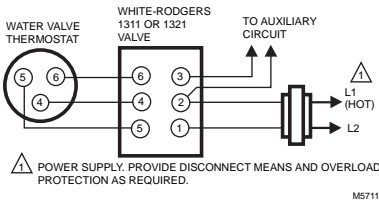

Fig. 26. Existing White-Rodgers System.

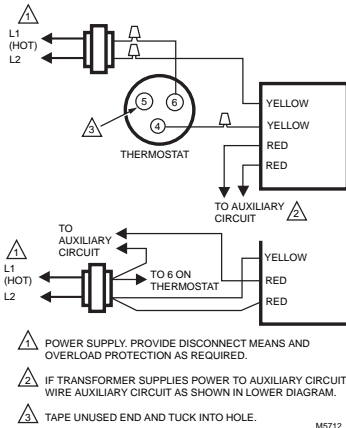

Fig. 27. Wiring a Honeywell V8043E to a White-Rodgers System.

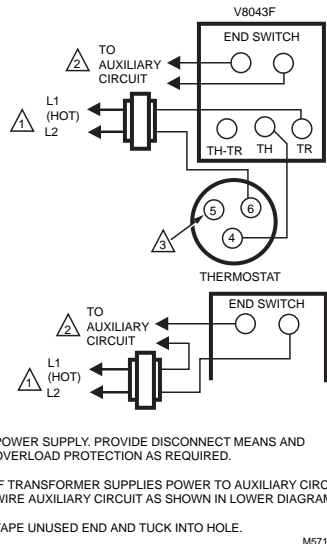

Fig. 29. Wiring a Honeywell V8043F to a White-Rodgers System (alternate option).

OPERATION AND CHECKOUT

CAUTION

On 24 V systems, never jumper the valve coil terminals even temporarily. This may burn out the heat anticipator in the thermostat.

NORMALLY CLOSED MODELS

With the manual opener set to AUTO and the powerhead energized, the valve is opened as shown in Fig. 30A. When the powerhead is de-energized, a spring-return mechanism drives the valve to the closed position as shown in Fig. 30B. The valve can also be opened with no electrical power by moving the manual opening lever over the stop and pushing slowly and firmly to the MAN. OPEN position. The stop permits the valve to be locked in the open position. The valve will return to the automatic position when the valve is energized.

Auxiliary switch is not energized when the valve is manually opened.

NORMALLY OPEN MODELS

When the powerhead is de-energized, a spring-return mechanism drives the valve to the open position (Fig. 30A). When energized, the valve is closed as shown in Fig. 30B. A reverse-acting thermostat is required to control a normally open valve.

NOTE: Inlet Port is stamped "A", Outlet Port is stamped "B" on the valve body.

Checkout

1. Raise the setpoint on the zone thermostat above the room temperature to initiate a call for heat.
2. Observe all control devices—the valve should open and the auxiliary switch should make the circuit to the circulator or other valve at the end of the opening stroke.
3. Lower the setpoint on the zone thermostat below the room temperature.
4. Observe the control devices. The valve should close and the auxiliary equipment should stop.

Service

This valve should be serviced by a trained, experienced service technician.

1. If the valve is leaking, drain the system and check to see if the O-ring needs replacing.
2. If the gear train is damaged, replace the entire powerhead assembly. See the Installation section. If the motor is burned out, replace the motor. See Replacement Parts list in the TRADELINE® Catalog.

NOTE: Honeywell zone valves are designed and tested for silent operation in properly designed and installed systems. However, water noises may occur as a result of excessive water velocity or piping noises may occur in high temperature (over 212° F [100° C]) systems with insufficient water pressure.

NOTE: These hydronic valves are not suitable for use in open loop systems where there is air exposure.

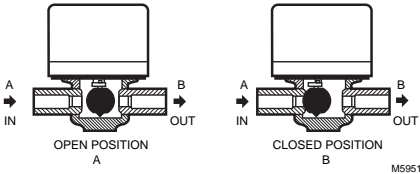

Fig. 30. V8043 operation for normally closed valve.

V4043, V4044 VALVES; V8043, V8044 ZONE VALVES

Automation and Control Solutions

Honeywell International Inc.
1985 Douglas Drive North
Golden Valley, MN 55422
customer.honeywell.com

© U.S. Registered Trademark
© 2010 Honeywell International Inc.
95-6983—11 T.D. Rev. 09-10
Printed in U.S.A.

Honeywell