

For Husqvarna Parts Call 606-678-9623 or 606-561-4983

**Rider 850, Rider 970,  
Rider 850 HST, Rider 970 HST,  
Rider 1030 Bioclip, Rider 1200**

**Workshop Manual**

101 89 11-26

**Workshop manual**  
**Rider 850, Rider 970,**  
**Rider 850 HST, Rider 970 HST,**  
**Rider 1030 Bioclip, Rider 1200**  
**Contents**

<b>Safety regulations</b> .....	2	Removal of swing axle .....	24
General instructions .....	2	Installation of swing axle .....	24
Special instructions .....	2	Removal/installation of gear box .....	25
<b>Special tools</b> .....	3	Removal/installation of hydrostatic transmission	
<b>Technical data</b> .....	4	Rider 850 HST/970 HST .....	26
Dimensions .....	4	Removal/installation of hydrostatic transmission	
Engine .....	4	Rider 1030/1200 .....	27
Gear box .....	4	Replacing hydrostat. trans. axle seals .....	29
Transmission .....	4	Ingoing axle .....	29
Control points .....	4	Outgoing axles .....	30
Play .....	4	Hydrostatic transmission brake .....	31
Tightening moments .....	4	Removal of brake .....	31
<b>Delivery measures</b> .....	5	Installation of brake .....	31
Measures before delivery .....	5	Adjustment of brake .....	32
Fastening steering wheel .....	5	Bleeding hydrostatic transmission oil system	33
Fastening seat .....	5	Adjustment of transmission neutral position ..	33
Fastening support wheels .....	6	Transmission maintenance .....	34
Fastening safety guard .....	6	Oil change .....	34
Refilling battery acid .....	6	Ineffective brake power .....	34
<b>Design and function</b> .....	7	Checking and adjusting cutting unit ground .....	
General .....	7	pressure Rider 970/1030 Bioclip/1200 .....	35
Engine .....	8	Checking and adjusting parallelism of the .....	
Steering .....	9	mowing deck .....	35
Driving .....	10	Adjusting Rider 1030 Bioclip/1200 .....	35
Mowing deck .....	11	Adjusting Rider 850 .....	36
<b>Reparation instructions</b> .....	12	Adjusting Rider 970 .....	36
Removing engine .....	12	Adjusting cutting height area .....	36
Replacing engine .....	14	Removal of mowing deck Rider 1030	
Checking and adjusting steering wires .....	17	and Rider 1200 .....	37
Replacing steering wires .....	18	Removal of mowing deck Rider 970 .....	37
Removal/installation of steering axle .....	18	Removal of mowing deck Rider 850 .....	38
Removal/installation of wire wheel .....	19	Replacing cutting unit belts .....	38
Checking and adjusting brake wire .....	20	Belt replacement on bioclip-unit .....	38
Checking and adjusting Rider 850/970 .....	20	Belt replacement on mowing deck with side-	
Checking and adjusting Rider		or rear discharge .....	39
1030 Bioclip/1200 .....	20	Removal of blades with bearings .....	40
Checking and adjusting gear control		Grinding and balancing of blades .....	41
Rider 850/970 .....	21	<b>Electrical system</b> .....	42
Checking and adjusting throttle control		Circuit diagram Rider 850 .....	42
Rider 1030 Bioclip/1200 .....	21	Circuit diagram Rider 970 .....	43
Checking and adjusting freewheel clutch		Circuit diagram Rider 850/970 HST .....	44
Rider 850/970 .....	22	Circuit diagram Rider 1030 Bioclip/1200 .....	45
Replacing articulated steering bearing .....	22		

## **Safety regulations**

### **General instructions**

The workshop handbook is written for personnel who are assumed to have general ride-on mower repair and service know-how.

The workshop where the ride-on mower is repaired should be equipped with safety devices in accordance with local regulations.

No-one should attempt to repair the ride-on mower without having first read and understood the contents of this handbook.

The machine is tested for safety and approved only for equipment supplied or recommended by the manufacturer.

The below-mentioned boxes are included in this workshop handbook, as is appropriate.



**WARNING!**  
The warning box indicates a risk of injury to persons if the instructions are not followed.

### **IMPORTANT INFORMATION**

This box indicates a risk of damage to the material if the instructions are not followed.

### **Special instructions**

The fuel used in the ride-on mower has the following hazardous characteristics:

- Toxic fluid and fumes
- Can cause eye and skin complaints
- Can cause breathing difficulties
- Highly flammable

When using compressed air, do not direct the compressed air stream towards your, or anybody else's, body. Air can be forced into the blood stream, thereby constituting a danger to life .

Use hearing protectors when test driving.

After test driving, do not touch the silencer before it has cooled down. Risk of burn injuries. This especially applies if the ride-on mower is equipped with a catalytic converter. If consumed, the lining on and in the catalytic converter element is dangerous to health. Use protective gloves when working with the catalytic converter/silencer.

The blades are sharp and can cause cutting injuries. Always use protective gloves when you are handling the blades.

Use protective glasses when working with the mowing deck. If the belt's tension spring comes off and flies upwards, this can cause injury to persons.

Be extra careful when handling battery acid. Spilling acid on the skin can cause severe burn injuries. If acid is spilt on the skin, rinse immediately with water. If acid gets into the eyes, this can cause blindness. Contact a doctor.

Be careful with the maintenance of the battery. Explosive gas is formed in the battery. Never handle the battery when smoking or in the vicinity of naked flames or sparks. Otherwise, the battery can explode and cause severe injuries.

## Special tools

The following special tools are used when working on the ride-on mower.

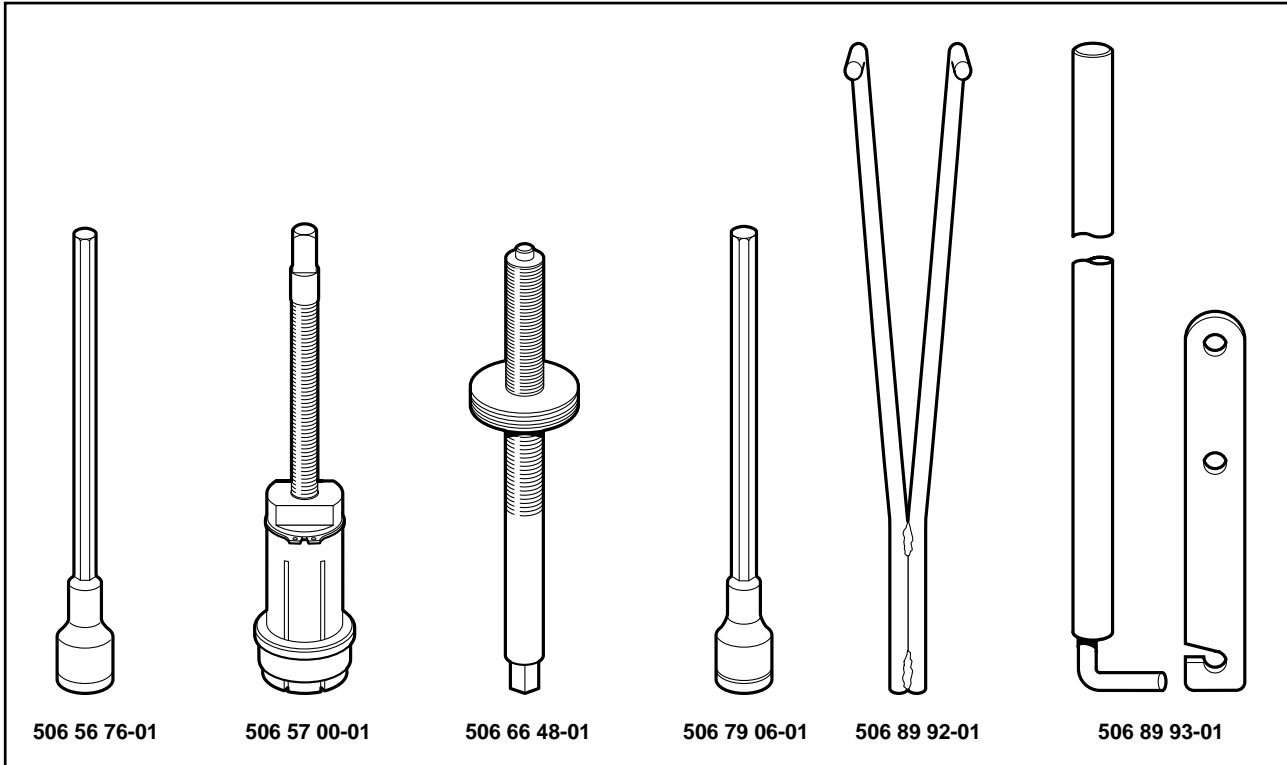

- |              |   |
|--------------|---|
| 506 56 76-01 | Ball-ended Allen key 5/16" to unscrew the engine pulley socket head cap screw (Kawazaki).         |
| 506 57 00-01 | Wheel puller for Rider 850 and Rider 970.   |
| 506 66 48-01 | Puller for engine pulley.   |
| 506 79 06-01 | Ball-ended Allen key 3/8" to unscrew the engine pulley socket head cap screw (Briggs & Stratton). |
| 506 89 92-01 | Holder-on for engine pulley removal.  |
| 506 89 93-01 | Tool for removing steer return spring.  |

## Technical data

### Dimensions

	Rider 850/850 HST	Rider 970/970 HST
Length	2000 mm	2145 mm
Width	960 mm	1050 mm (970) 1260 mm (970 S) 1120 mm (970-Bioclip)
Height	1060 mm	1060 mm
Unladen weight	225 kg	240 kg
Wheel base	820 mm	855 mm
Track	610 mm	Front: 715 mm Rear: 610 mm
		Front: 710 mm (970-Bioclip) Rear: 620 mm (970-Bioclip)
Tyre size	16x6, 50x8	16x6, 50x8

	Rider 1030 Bioclip	Rider 1200
Length	2300 mm	2300 mm
Width	1120 mm	1280 mm
Height	1085 mm	1085 mm
Unladen weight	300 kg	300 kg
Wheel base	855 mm	855 mm
Track	710 mm	710 mm
Tyre size	18x7, 50x8	18x7, 50x8

### Engine

	Rider 850	Rider 850 HST
Manufacture	Briggs & Stratton 28B707, type 0139, trim 01	Briggs & Stratton 286707, type 0184, trim 01
Power	7.7/10.5 kW/hp	9.2/12.5 kW/hp
Displacement	362 cm <sup>3</sup>	465 cm <sup>3</sup>
Oil volume	1.2 litres	1.2 litres

	Rider 970/970 HST	Rider 1030/1200
Manufacture	Briggs & Stratton 28N707, type 0189, trim 01	Briggs & Stratton V-Twin, 350777 type 1123, trim A1
Power	11.4/15.5 kW/hp	13.7/18 kW/hp
Displacement	465 cm <sup>3</sup>	570 cm <sup>3</sup>
Oil volume	1.2 litre	1.3 litre

### Gear box

	Rider 850	Rider 970
Manufacture		
Europe	Peerless MST 205-531A	Peerless MST 205-531A
USA	Peerless MST 205-530A	Peerless MST 205-530A
Gears, forwards	5	5
Gears, reverse	1	1

### Transmission

	Rider 850 HST	Rider 970 HST
Manufacture	Kanzaki K55 hydrostatic	Kanzaki K55 hydrostatic

	Rider 1030 Bioclip	Rider 1200
Manufacture	Kanzaki K61 hydrostatic	Kanzaki K61 hydrostatic

### Control points

Mowing deck parallelism with cutting height in pos. 1:	$\pm 2$ mm
Cutting height control in pos. 1:	850 = $37 \pm 2$ mm Bioclip = $45 \pm 2$ mm Other = $40 \pm 2$ mm
Synchronous transmission belt tension	
Bioclip at 10 N force, impression:	7 mm
Dist. between support plate and drive belt:	3–6 mm
Distance belt tensioner control lever and belt guide, disengaged unit:	$17 \pm 5$ mm

### Play

Clutch wire:	8–10 mm
Brake control lever against stop bolt:	0–1 mm
Brake control lever:	7–9 mm
Brake wire hydrostatic transmission:	0 mm

### Tightening moments

Carrier steering	5–10 Nm
Pulley steering wire	20–30 Nm
Belt wheel	35–40 Nm
Blades	45–50 Nm
Blade bearings	20–25 Nm
Belt tensioner wheel	15–25 Nm
Holder screws, engine	20–25 Nm
Holder screws, gear box	20–25 Nm
Brake drum bolts hydrostatic transmission	27 Nm
Engine pulley	70–80 Nm
Wheel axle nut	100–150 Nm

## Delivery measures

### Measures before delivery

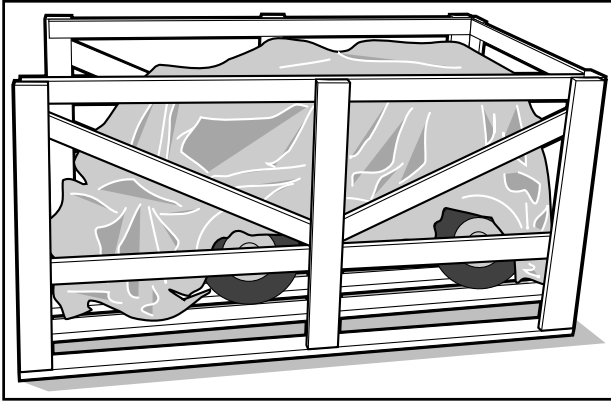

A Husqvarna Rider is delivered from the factory on a pallet and wrapped in plastic. For reasons of space, certain measures must be carried out on the ride-on mower before it can be delivered to the customer.

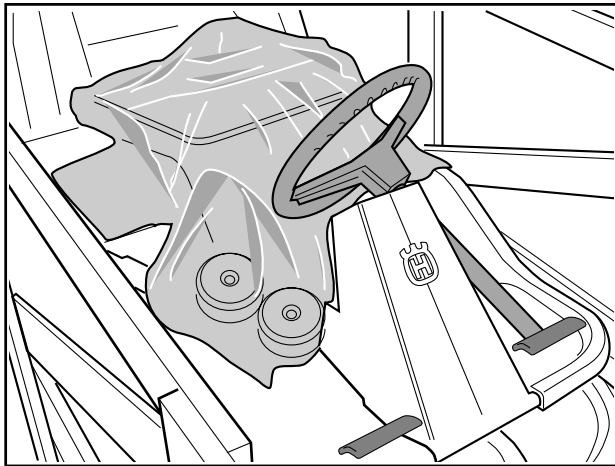

The following must be carried out by the dealer before delivery:

- The steering wheel must be fastened.
- The seat must be fastened.
- On Rider 850, the support wheels are to be fastened on the mowing deck.
- Safety guard is to be fastened on Rider 1030 Bioclip and Rider 1200.
- The battery must be filled with battery acid before it is used.

### Fastening steering wheel

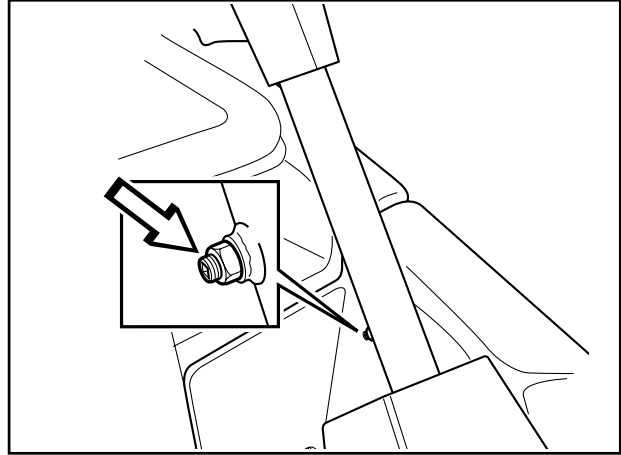

- Fasten the steering wheel with steering column on the steering shaft.
- Tighten the socket head cap screw, make sure that it sits in its groove on the steering shaft.
- Securely lock the socket head cap screw with the locking nut.

### Fastening seat

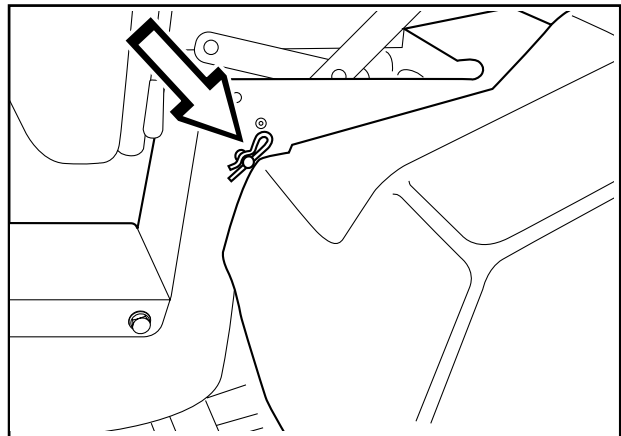

Insert the seat pin through the hole in the frame and seat attachment and fasten spring pin.

### IMPORTANT INFORMATION

**On Rider 1030 Bioclip and Rider 1200 the safety system contact is to be assembled under the seat. Check the correct functioning of the contact after delivery measures have been carried out. The machine should not function if there is no-one sitting in the driver's seat.**

Before delivery

## Fastening support wheels

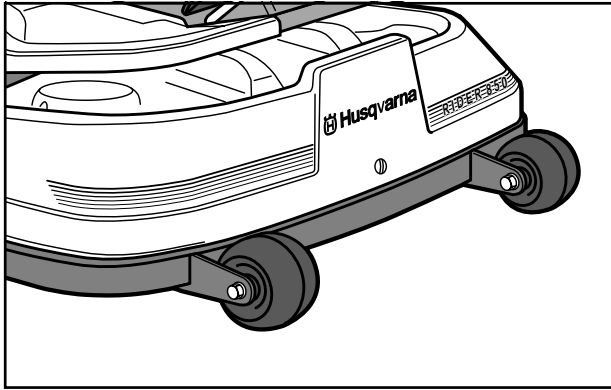

Fasten the support wheels with axles, spacers and nuts in the support wheels holder.

## Fastening safety guard

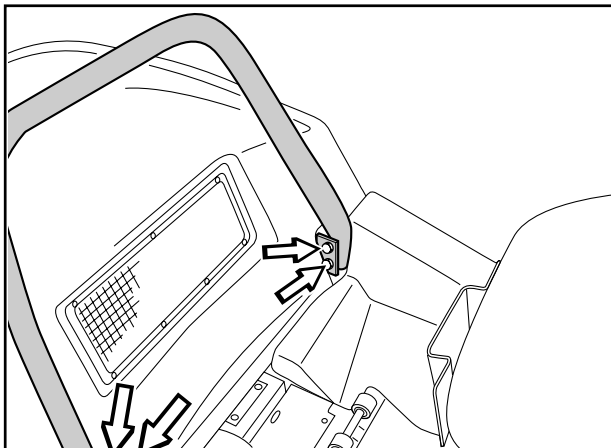

On Rider 1030 Bioclip and Rider 1200, a safety guard is to be assembled.

Screw the four accompanying screws into the engine guard holder.

## Refilling battery acid

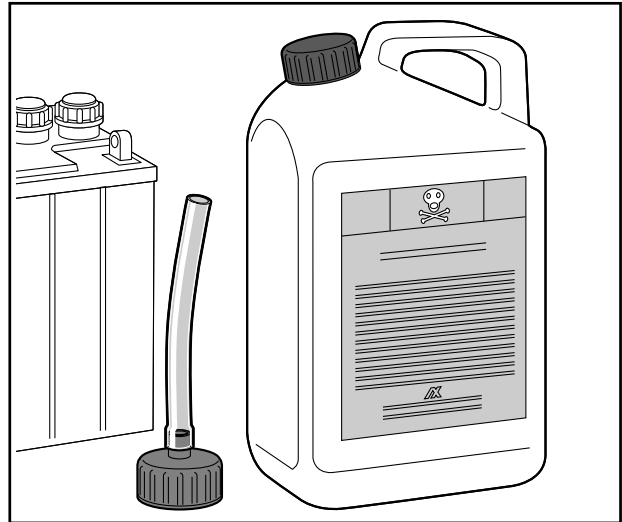

The battery is delivered dry from the factory.

- Slowly fill the battery acid up to the mark on the battery.
- Wait 20 minutes and fill, as is required, with more battery acid.
- Charge the battery (12V, 6A) for one hour.
- Check the level of acid and fill, as is required, with distilled water up to the correct level.



### WARNING!

The battery acid is highly corrosive. Use rubber gloves and protective glasses. Avoid breathing in the acid fumes.

#### Measures for contact with acid

**External:** Rinse thoroughly with water.

**Internal:** Drink large quantities of water or milk. Contact a doctor as soon as possible.

**Eyes:** Rinse thoroughly with water. Contact a doctor as soon as possible.

The battery gives off explosive gas. Sparks, naked flames and cigarettes must absolutely not be in the near vicinity of the battery.

## Design and function

### General

Husqvarna Riders is a series of ride-on mowers with a large capacity. There are four sizes, from the smallest Rider 850 to the largest Rider 1200 (the figures indicate the cutting width in mm).

All Riders have articulated steering in order to easily cut around trees and other obstacles. Moreover, they all have front-mounted mowing decks for controlled cutting and for best possible cutting results.

Husqvarna Riders can, moreover, be equipped with various accessories such as moss rake and dozer blade which make them flexible working tools throughout the year.

Rider 850 and Rider 970 can be delivered with a manual gear box or with hydrostatic transmission. Rider 1030 and Rider 1200 are only available with hydrostatic transmission.

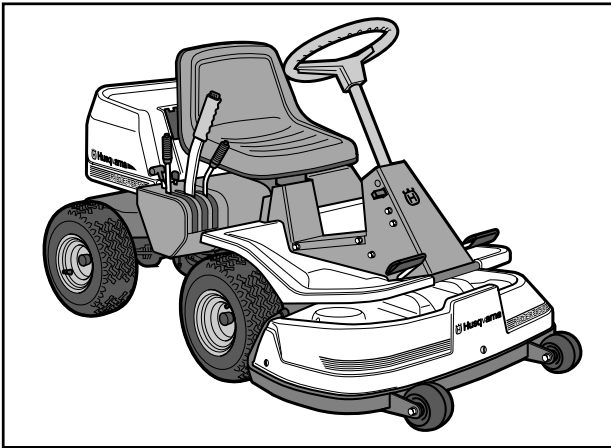

Rider 850 has a mowing deck with rear ejection.

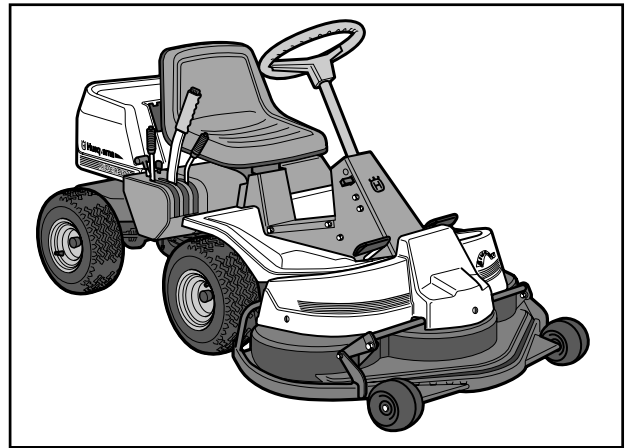

Rider 970 can be delivered with three different mowing decks; with rear ejection, side ejection or, as the picture shows, with a bioclip-deck.

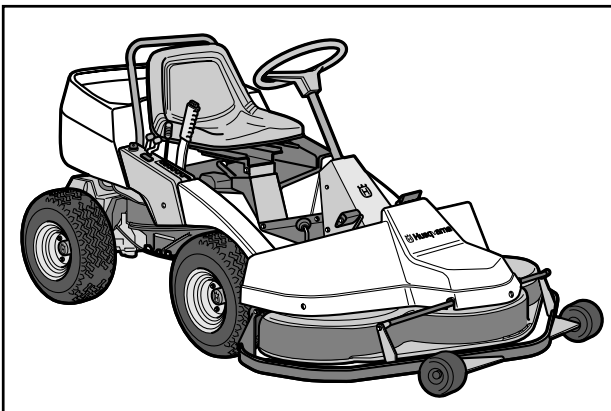

Rider 1030 Bioclip. This is the larger Rider model. It is technically similar to the Rider 1200, apart from the fact that it has a bioclip-deck.

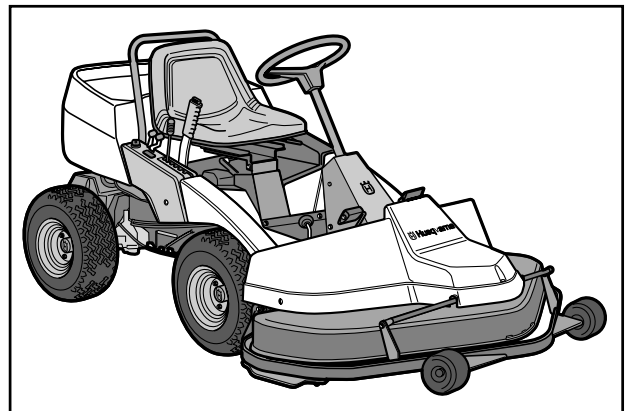

Rider 1200 has a mowing deck with rear ejection.



## Engine

All Husqvarna Riders have engines from Briggs & Stratton. Rider 850 and Rider 970 have single-cylinder engines whilst Rider 1030 Bioclip and Rider 1200 have two-cylinder engines. Both the single and two-cylinder engines are air cooled.

More intricate engine repairs are not described in this workshop handbook, these can instead be read in Briggs & Stratton's own handbooks which contain detailed information about adjusting and repairing the engines. The handbooks can be ordered from an authorized service workshop.

The order numbers for the respective handbooks are found in the table below:

Model	B & S art. no.
Rider 850	270962
Rider 970	270962
Rider 1030	805845
Rider 1200	805845

It is important that only original spare parts are used when repairing the engines. If other parts are used, the guarantee shall no longer be valid.

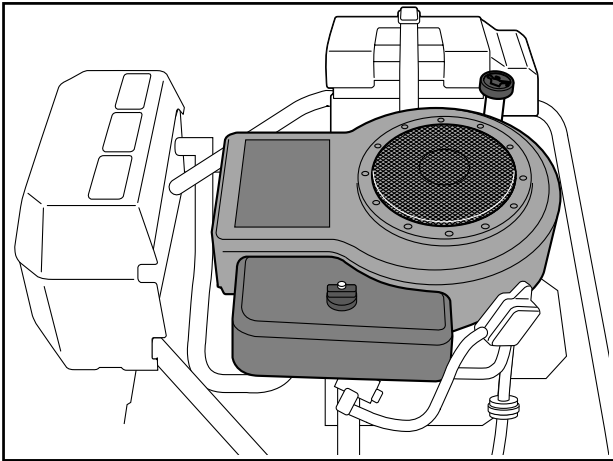

Rider 850 has a 10.5 or 12.5 hp single-cylinder side valved engine with spray lubrication.

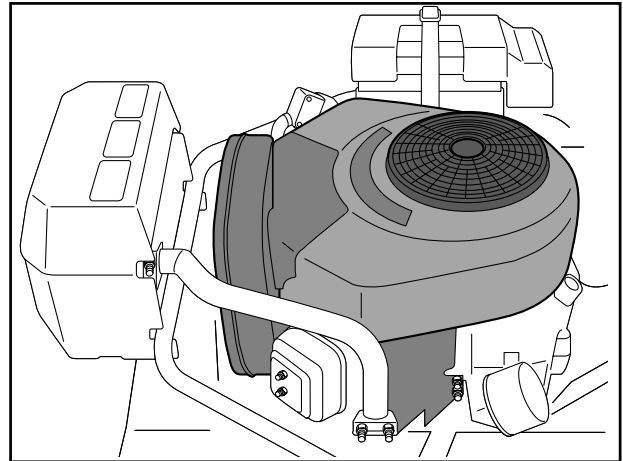

Rider 1030 Bioclip and Rider 1200 have 18 hp two-cylinder top valved engines with pressure lubrication and a separate oil filter. These engines can also be equipped with catalytic converters which reduce hydrocarbon and nitrogen oxide emissions by up to 65% and carbon monoxide emissions by 45%.

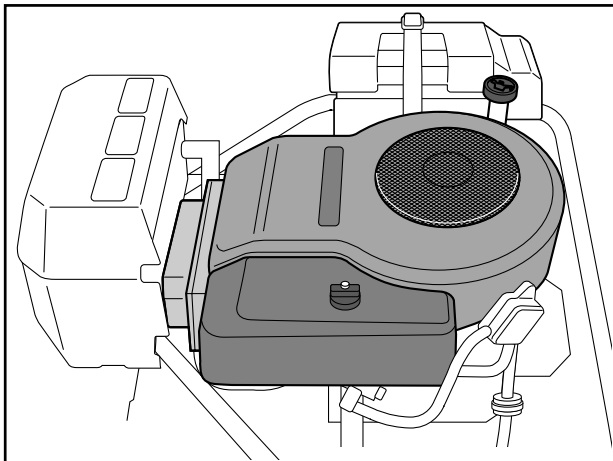

Rider 970 has a 15.5 hp single-cylinder, top valved engine with spray lubrication.

## Steering

All the ride-on mowers in Husqvarna's Rider-series have articulated steering. The steering force from the steering wheel is transferred to the rear section via wires and a chain. This ensures that the ride-on mower is easy to manoeuvre, as well as having high-precision steering. A Rider easily cuts around all obstacles that may be found on the lawn.

Thanks to the articulated steering, the turning radius is extremely small, the uncut circle when the steering wheel is fully turned is just 20 cm for the Rider 850.

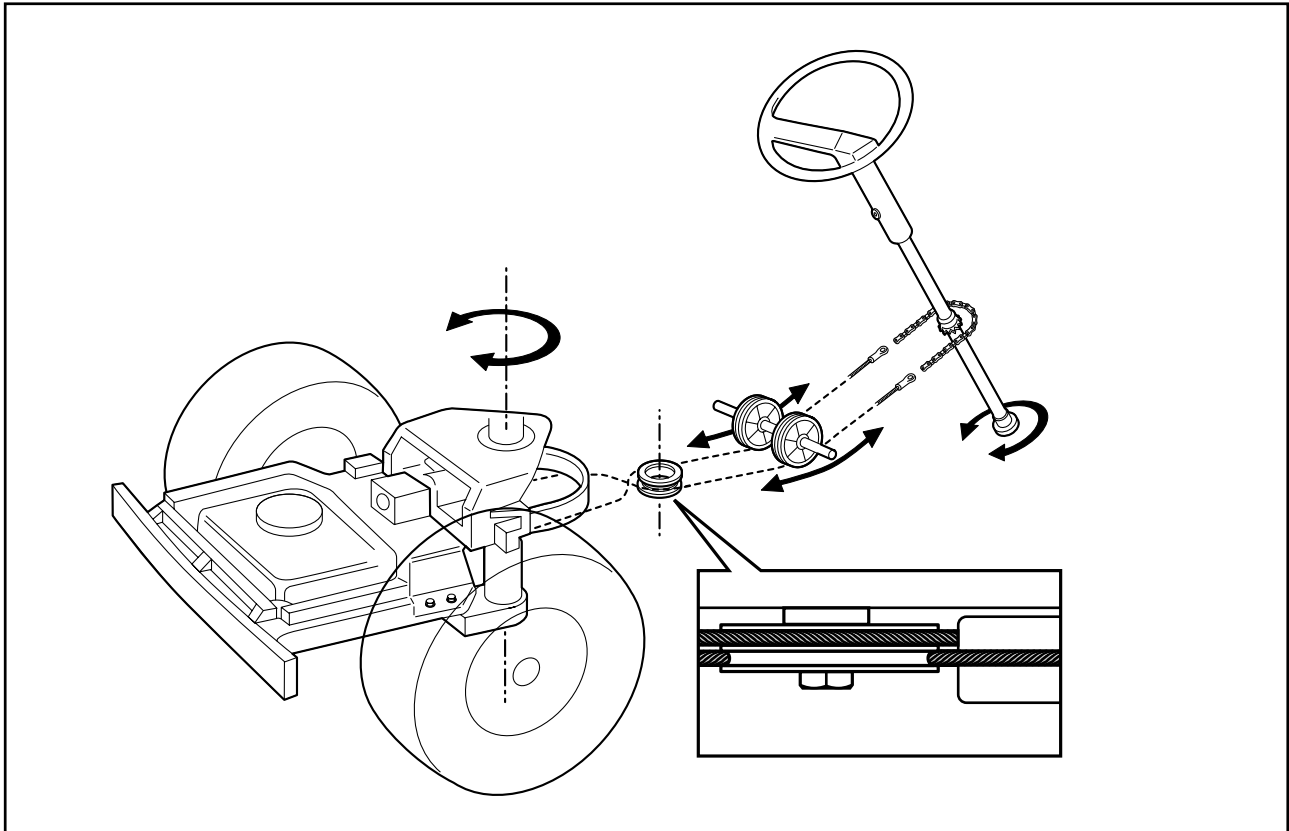

Outline diagram of the articulated steering function.

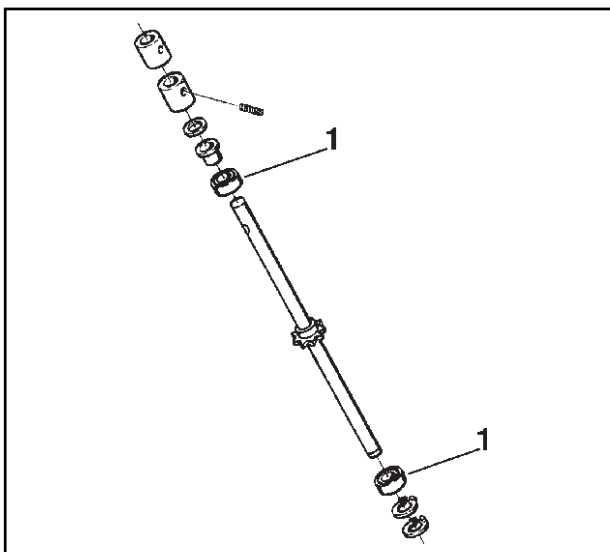

Rider 850 HST, Rider 970, Rider 970 HST, Rider 1030 Bioclip and Rider 1200 have a roller bearing (1) steering column.

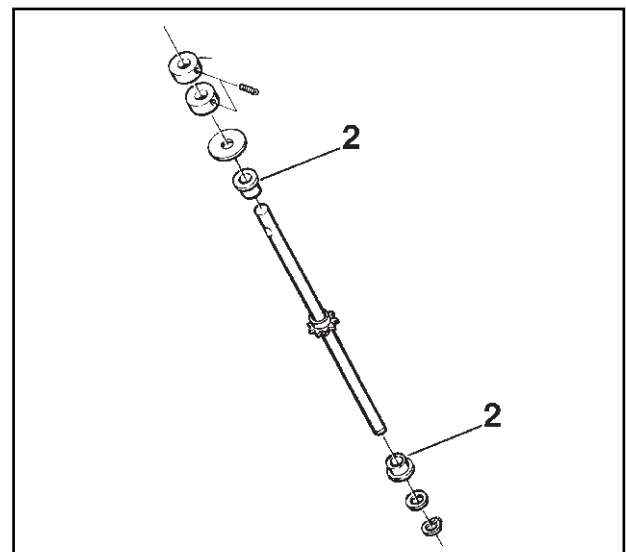

Rider 850 has a sliding bearing (2) steering column.

## Driving

Rider 850 HST, Rider 970 HST, Rider 1030 Bioclip and Rider 1200 are equipped with hydrostatic transmission which provides the driver complete control. Continuously variable speed control, forwards and reverse, is by means of a foot pedal.

Rider 850 and Rider 970 have a manual gear box with five forward gears, neutral and one reverse gear. This gear box is an "inline" type, which means that you can change from neutral to fifth gear without having to go through all the other gears.

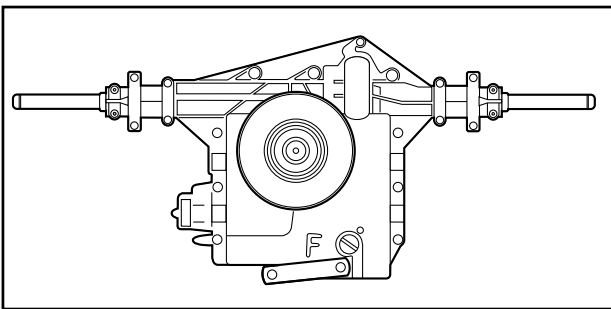
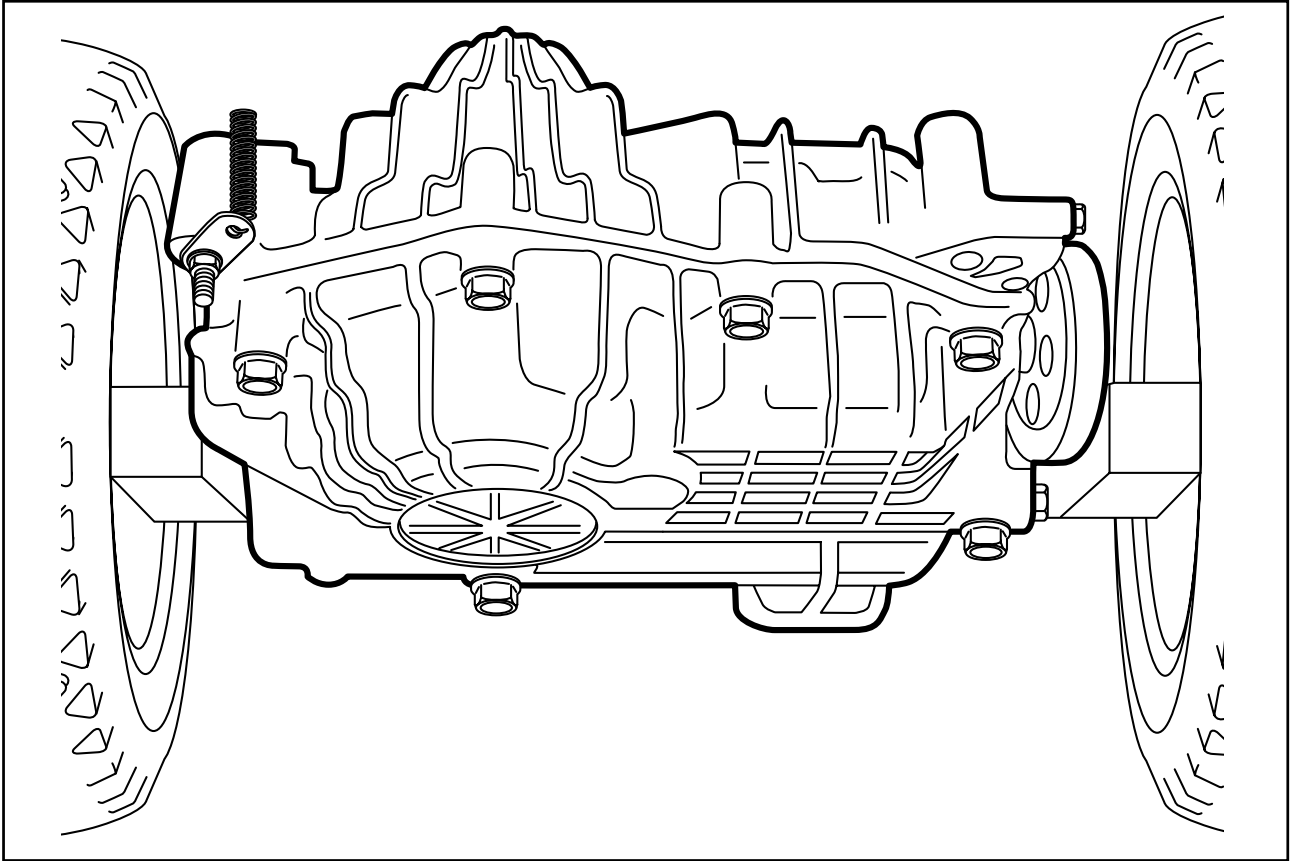

Manual gear box on Rider 850 and Rider 970.

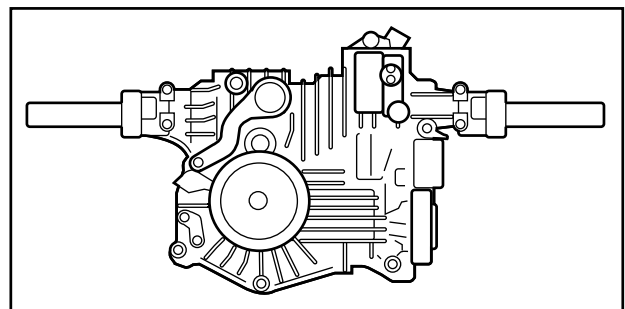

Hydrostatic transmission on Rider 1030 and Rider 1200.

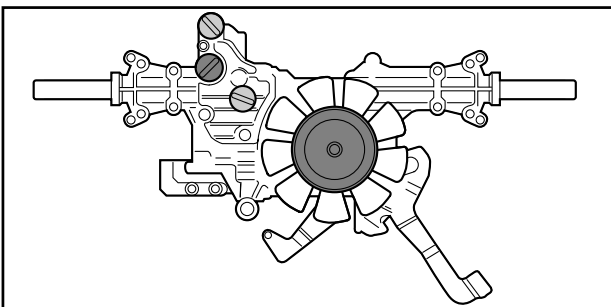

Hydrostatic transmission on Rider 850 HST and Rider 970 HST.

## Mowing deck

The entire Rider-series is equipped with front-mounted, floating three-blade mowing decks for effective cutting of uneven surfaces.

Rider 850 has a mowing deck with rear discharge and a cutting width of 850 mm.

Rider 970 can be delivered with different types of mowing deck: rear discharge, side discharge or with a bioclip-deck. Rider 970 has a cutting width of 965 mm, although the bioclip-version has a cutting width of 1030 mm.

Rider 1030 Bioclip has a bioclip-deck and a cutting width of 1030 mm.

Rider 1200 has a mowing deck with rear discharge and a cutting width of 1200 mm.

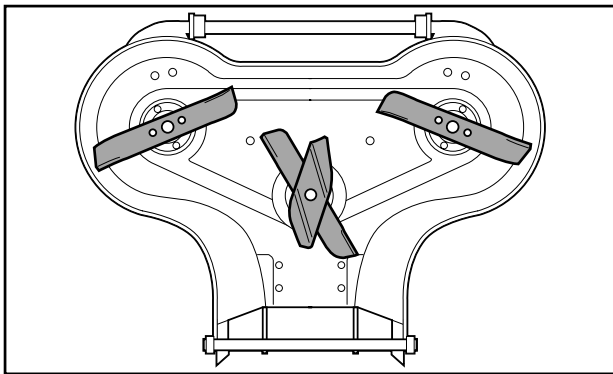

Mowing deck on a Rider 850 (rear discharge).

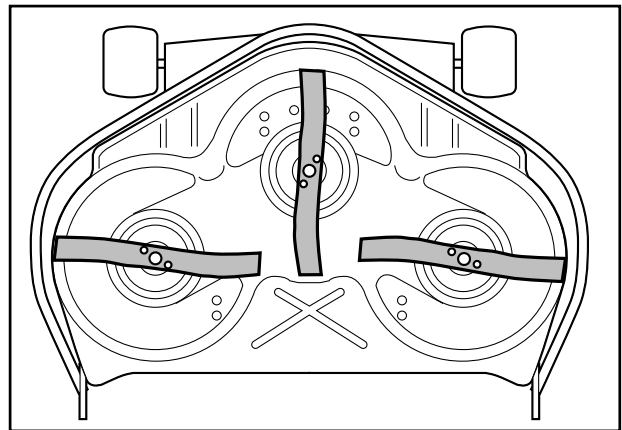

Mowing deck on a Rider 1030 Bioclip (also used on Rider 970 Bioclip).

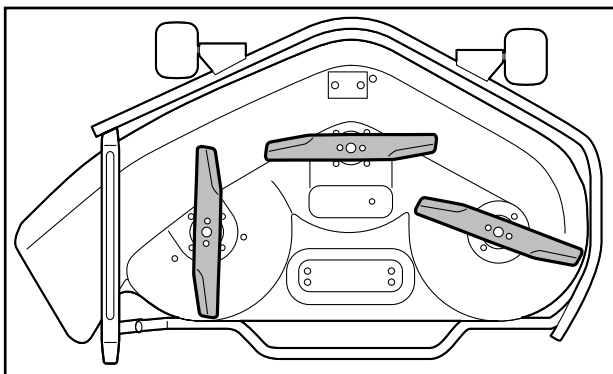

Mowing deck on a Rider 970 S (side discharge).

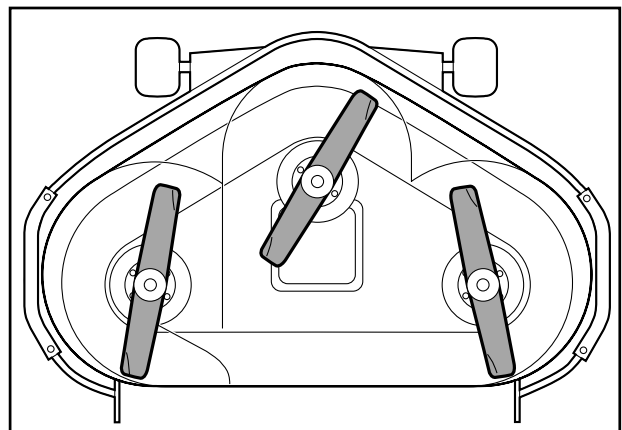

Mowing deck on a Rider 1200 (rear discharge).

## Reparation instructions

### Removing engine

1

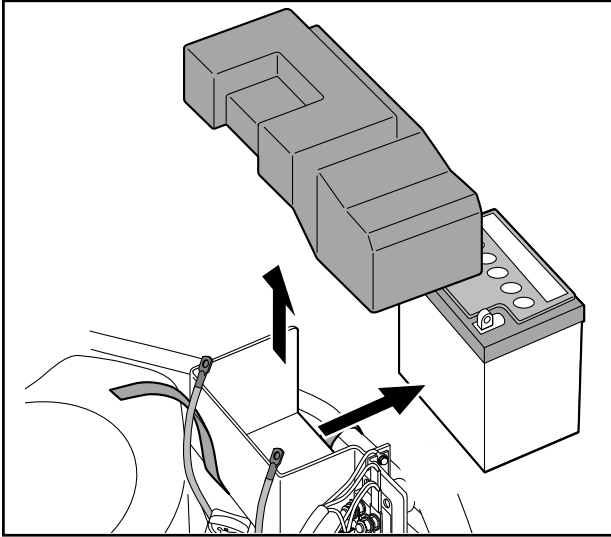

Remove the battery's fixing belt. Remove the safety guard and remove the cable connections. Then, lift out the battery.

3

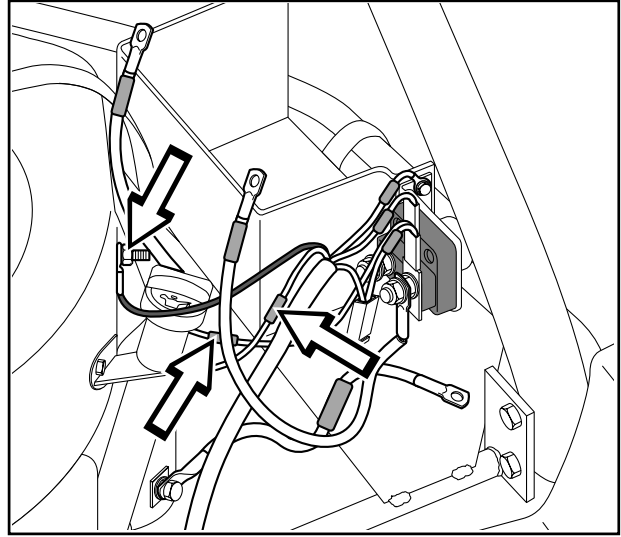

Mark up and remove the engine's electrical connections.

2

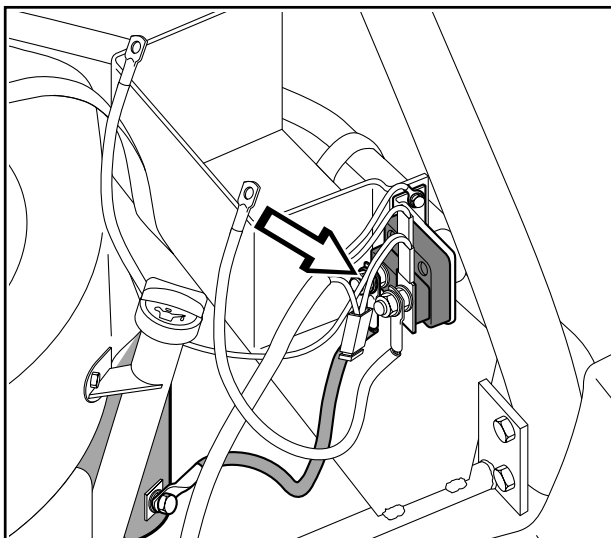

Remove the cable which leads from the starter relay to the start motor.

4

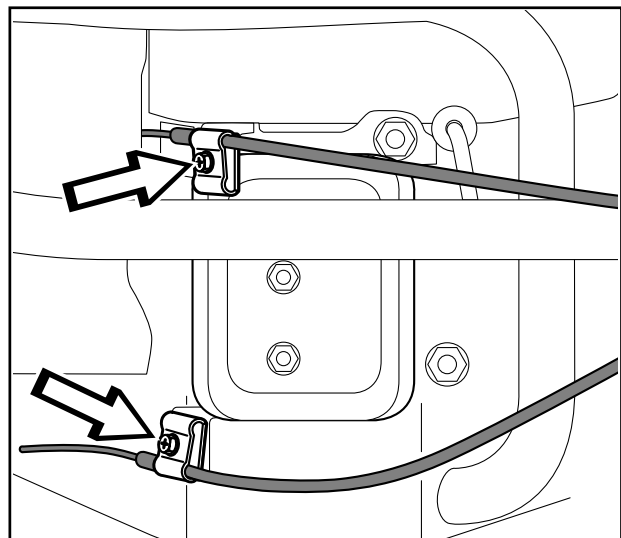

Remove the clamps which hold the throttle and choke wires. Unhook the wires from their attachment in the carburettor.

**Rider 850/970 have just one wire which controls both the throttle and the choke.**

5

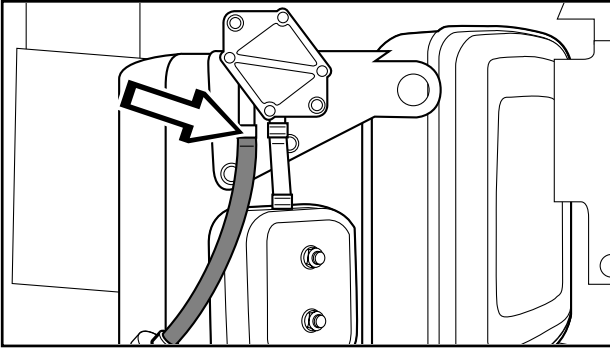

Remove the fuel line hose clamp from the fuel pump and pull the fuel line downwards.

7

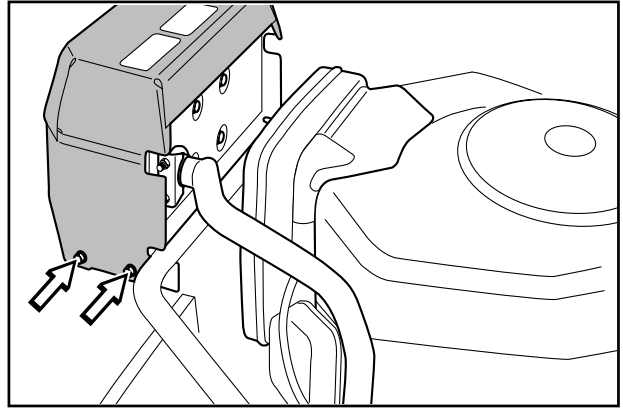

Remove the cover plate over the silencer (two screws on either side of the silencer) and lift out the plate.

6

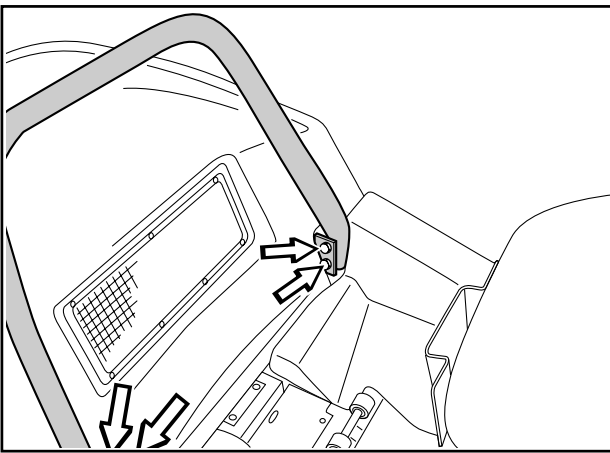

Unscrew the safety guard attachments, (two screws on each side) and lift out the safety guard.  
**Rider 850/970 do not have a safety guard.**

8

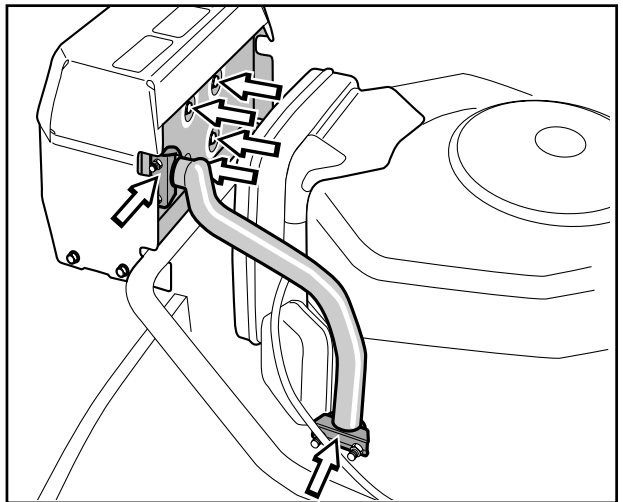

Remove the exhaust pipe clamps and the silencer's four holder screws. Then remove the silencer and the exhaust pipe.

**On Rider 850/970, the exhaust pipe is removed without removing the silencer.**

9

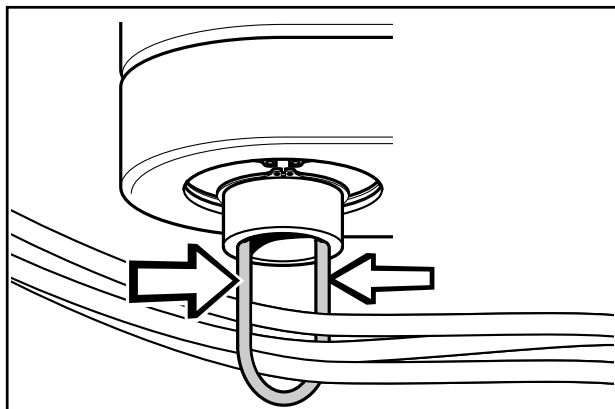

Clamp together the wire holder under the engine pulley with a pair of flat pliers and pull the wire holder downwards.

11

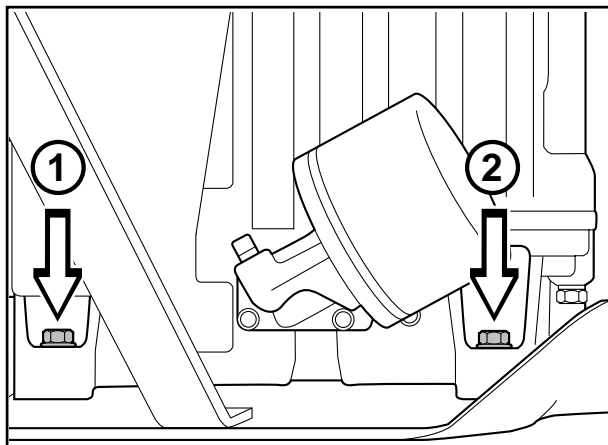

Remove the engine attachments, two on each side of the engine, and remove the engine from the mower.

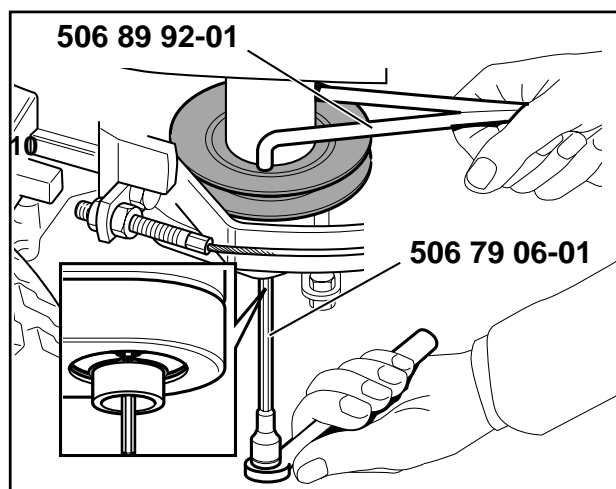

Insert tool no. 506 79 06-01 into the centre of the engine pulley. Unscrew and remove the socket head cap screw which holds the pulley and the engine axle together. Use tool no. 506 89 92-01 as a holder-on. Remove the pulley from the engine axle.

## Replacing engine

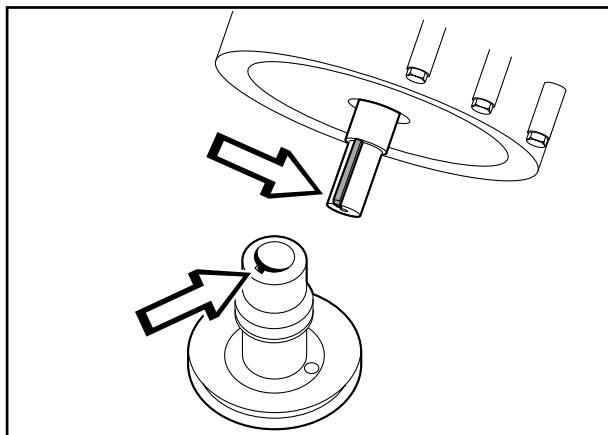

### IMPORTANT INFORMATION

When installing the engine, it is important that the pulley groove (1) is in a position so the outgoing axle key (2) fits into the groove (see diagram). Also check that both spacing collars (3) and the key (2) are firmly attached on the engine axle. Grease the engine axle.

1

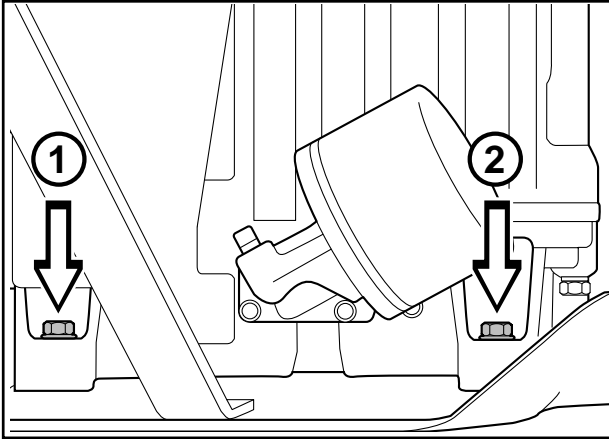

Lower the engine and tighten the engine attachments (two on each side of the engine) with moment (25 Nm).

3

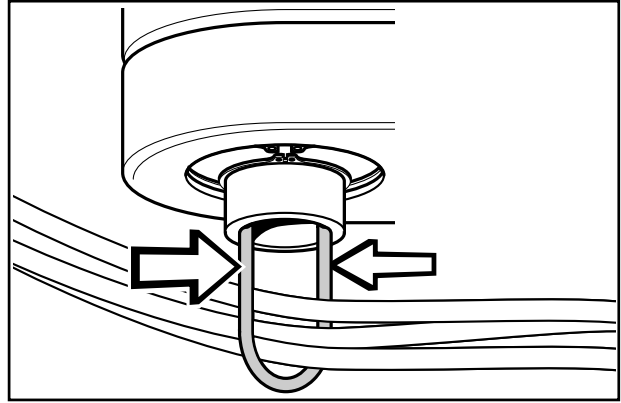

Position the wires in the wire holder, clamp the holder together and, from below, lead it up through the centre of the belt tensioner until it hooks over the tensioner's upper edge.

2

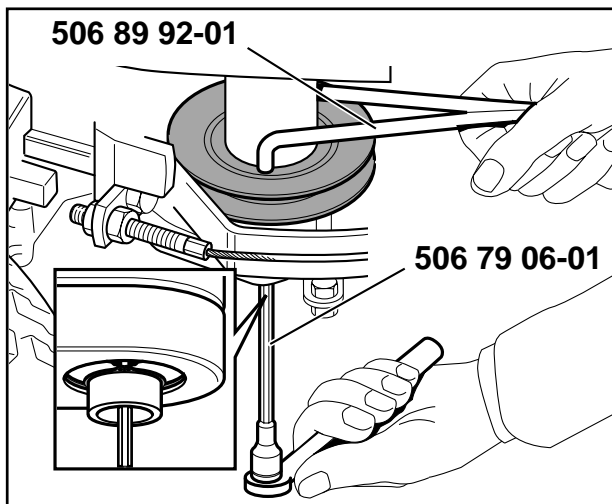

Position the pulley with tool no. 506 79 06-01 and tighten it with moment (80 Nm). Use tool no. 506 89 92-01 as a holder-on.

4

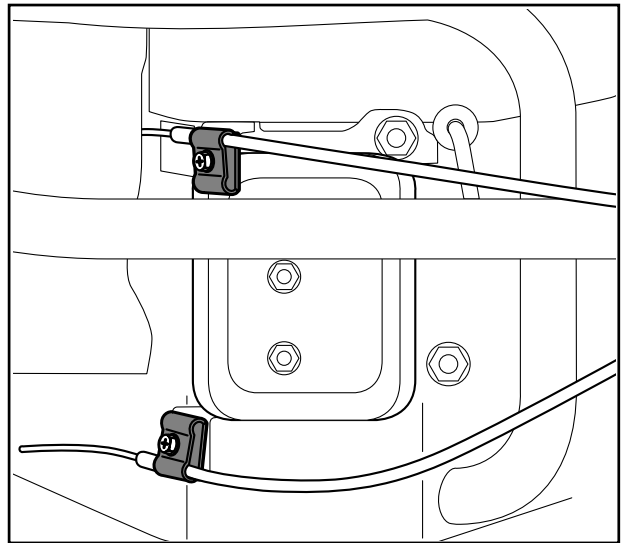

Attach the throttle and choke wires to the carburettor and position the wire clamps without tightening them.



5

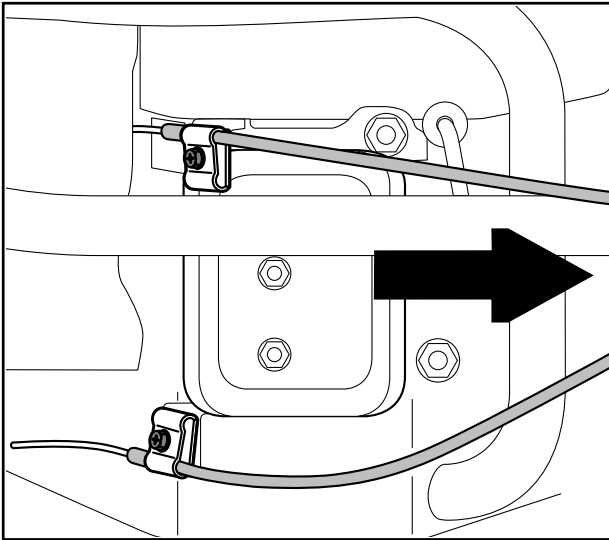

Set the throttle control to full throttle and the choke control to full choke. Pull the wires' outer cover as far as possible to the right and tighten the clamp screws.

**Rider 850/970** have *one* wire to the gas/choke control.

6

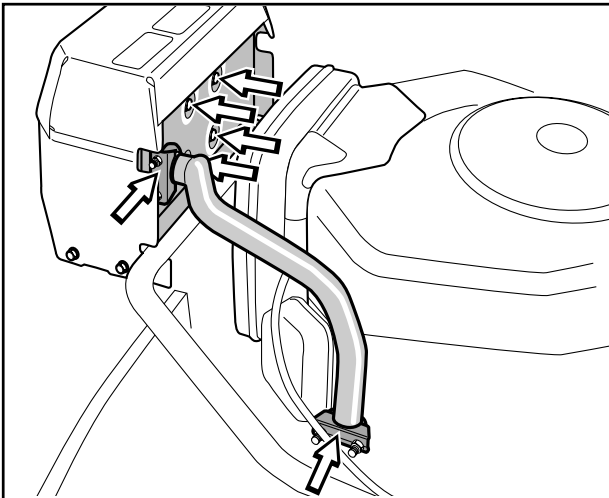

Attach the silencer and exhaust pipe and tighten the holder screws and pipe clamps.

**Rider 850/970:** *only* exhaust pipe.

7

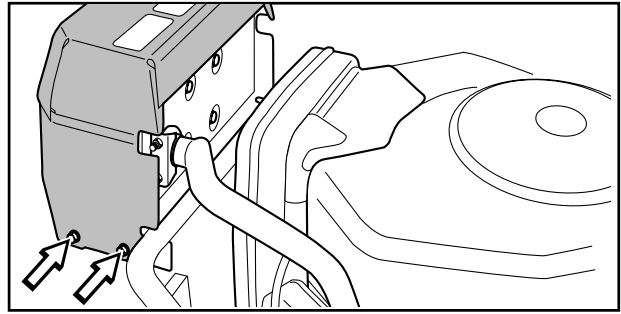

Securely fasten the protective plate over the silencer, two screws on each side of the silencer.  
**Only Rider 1030/1200.**

8

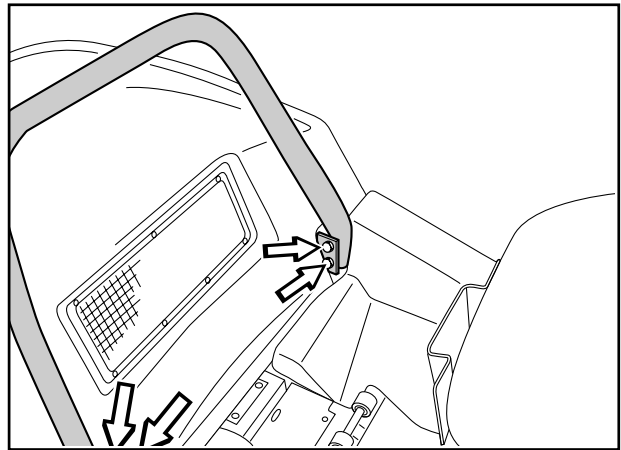

Attach the safety guard.  
**Only Rider 1030/1200.**

9

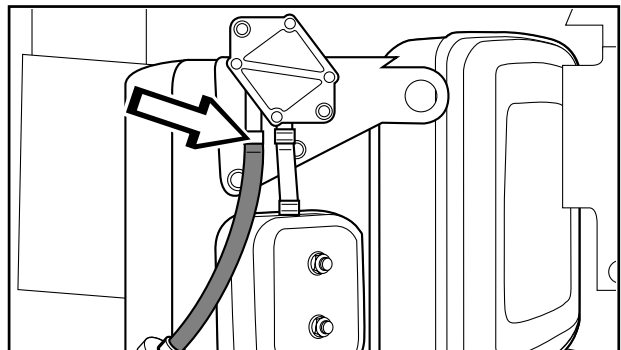

Firmly press the fuel line against the fuel pump and tightly screw the pump's upper hose clamp.

10

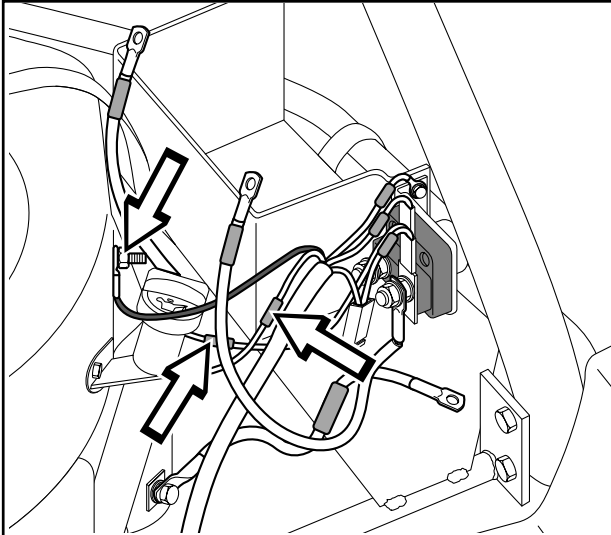

Attach the engine's electrical connections.

11

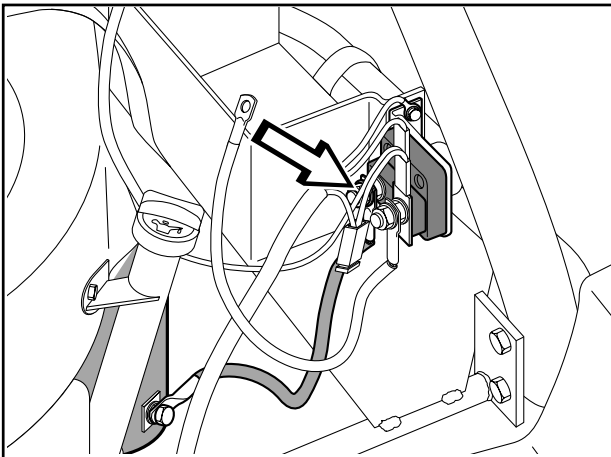

Tightly screw the cable from the start motor to the starter relay.

12

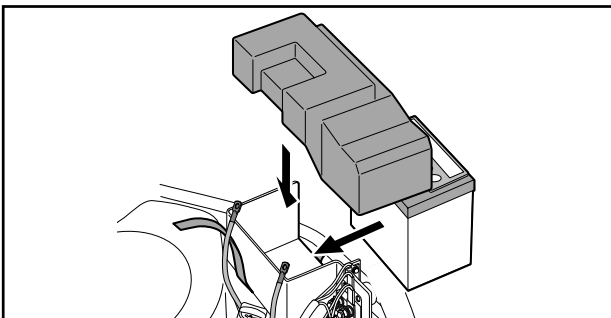

Lift the battery into place and fasten the cable connections and safety guard. Tighten the catching belt.

## Checking and adjusting steering wires

1

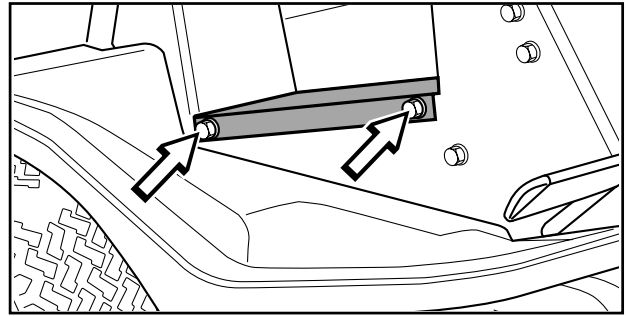

Remove the frame plate by releasing the screws (two on either side).

2

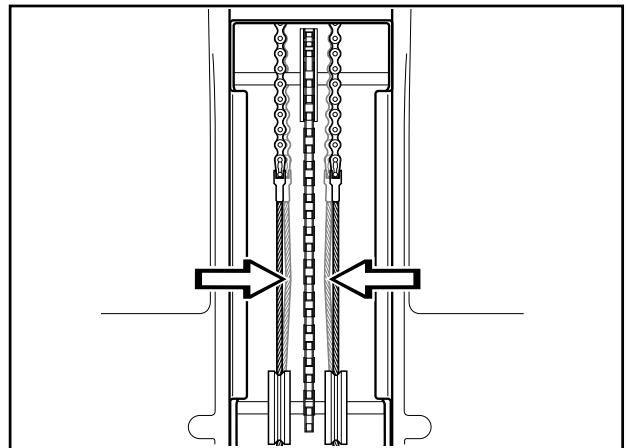

The tension is checked by squeezing together the wires (as shown in the diagram). Without having to apply too much force, the wires should be able to be squeezed to half the distance between them.

3

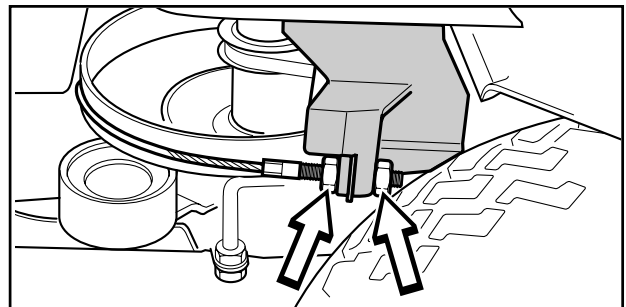

Stretch the wires by tightening the adjuster nuts (one wire on each side of the ride-on mower). Do not overtension them, they should only be tightened up to the steering rim. Stretch both wires equally so that the steering wheel position is not changed. Check the wire tension after adjustments have been made, in accordance with point 2.

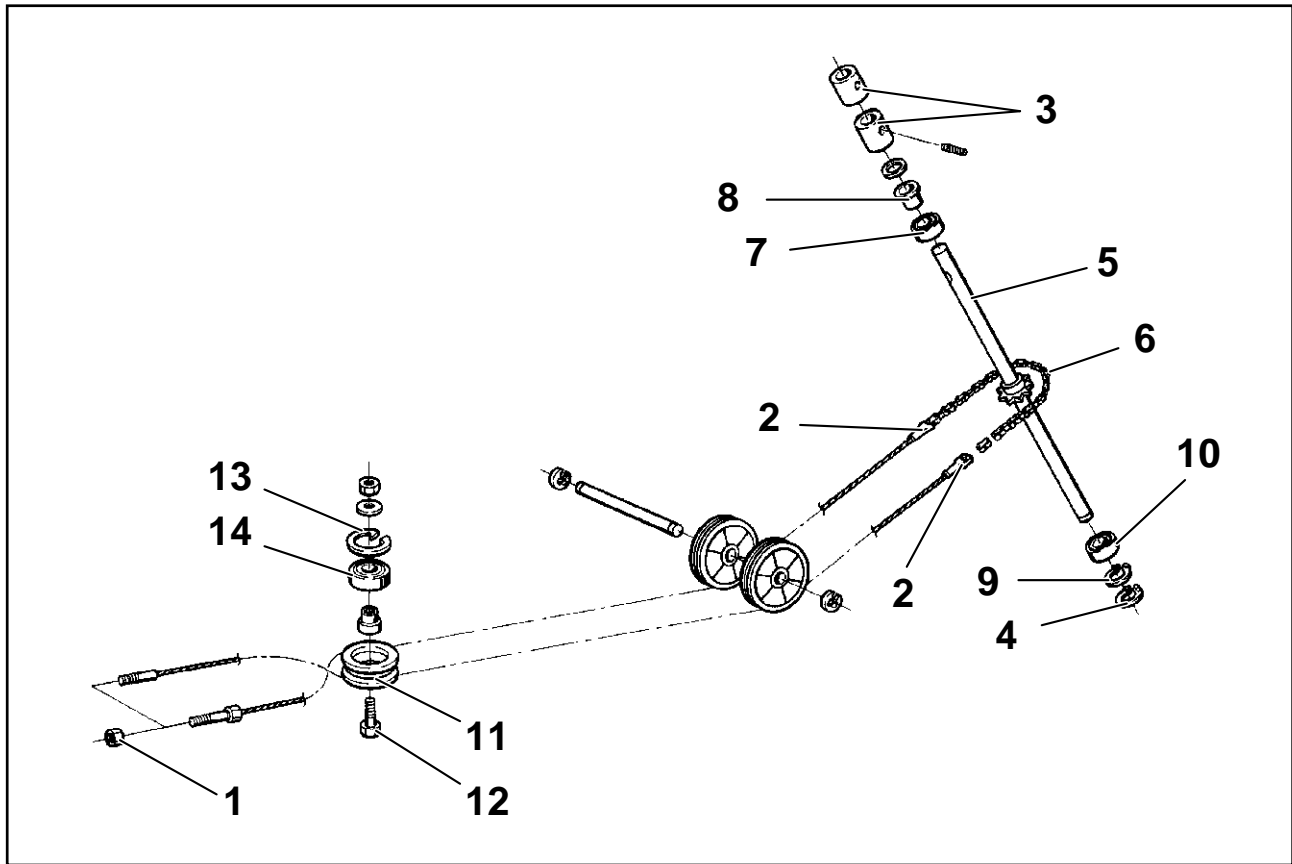

## Replacing steering wires

- 1**  
Release the steering wires' rear attachment (1).
- 2**  
Release the steering wires' front attachment (2) at the steering transmission chain (6) and pull the steering wires out through the frame.  
**Note.** If the old wires are still complete, the new wires can be attached to the old ones when they are pulled out through the frame, the new wires will then come automatically into place.
- 3**  
Attach the new wires.  
Once the new wires are in place, check the wire tension (see page 17).

## Removal/installation of steering axle

- 1**  
Release the steering wires' rear attachment (1).  
Remove the frame plate (see page 17).
- 2**  
Remove the steering wheel and steering column by releasing the lock nut and unscrewing the locking screw, lift the steering wheel and steering column upwards.
- 3**  
Remove the two steering wheel rod carriers (3).
- 4**  
Remove the steering wheel rod circlip (4).
- 5**  
Pull the steering axle (5) upwards and move the lower part of the axle backwards to remove the steering transmission chain (6).
- 6**  
Move the upper bearing (7) upwards until it goes free from the steering axle (5). If the bearing is to be replaced, the bushing (8) must be knocked out of the bearing.

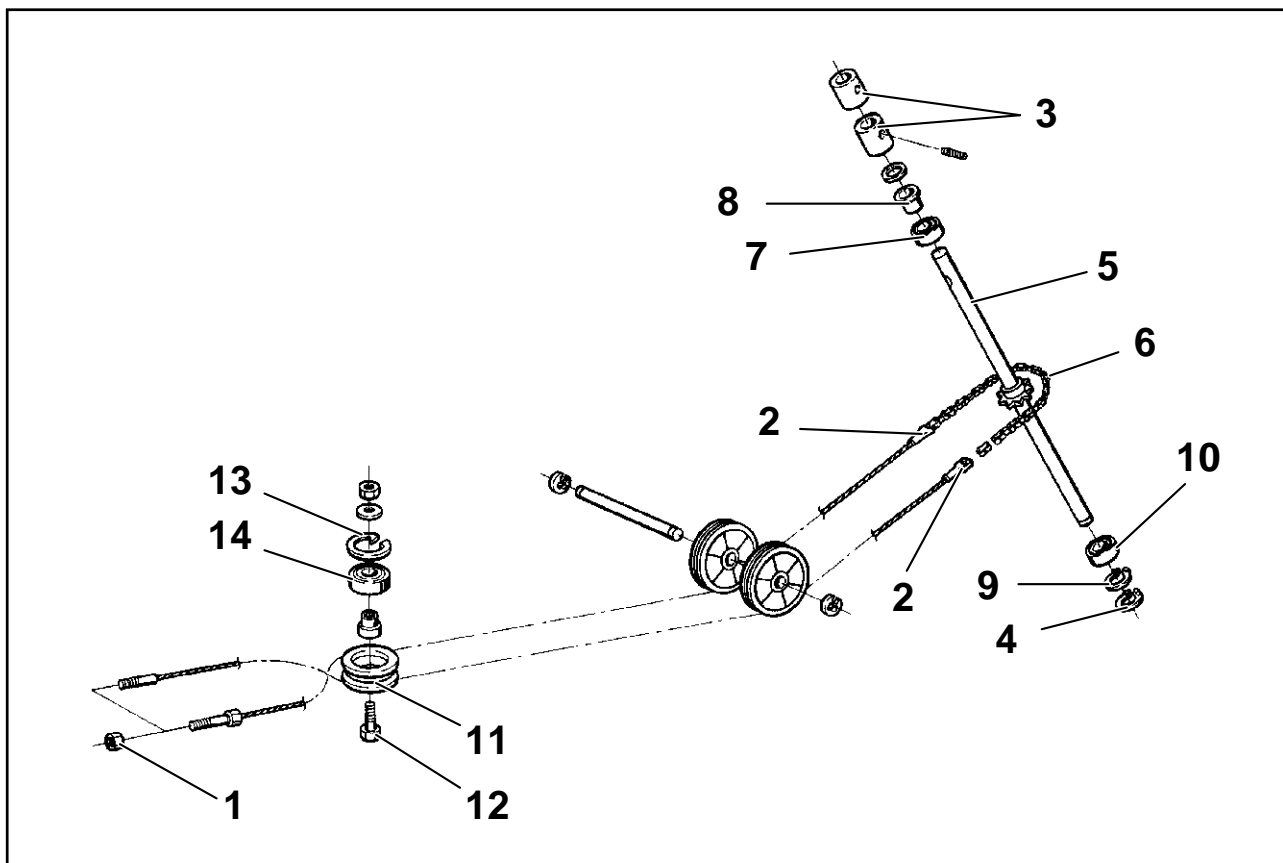

**7**  
Remove the lower bearing's circlip (9) and take the bearing (10) out downwards.

**8**  
Take the steering axle out (5) downwards.

**9**  
To assemble the steering axle, the reverse order is applied. For assembly purposes, the two steering wheel rod carriers (3), are tightened with moment (5–10 Nm).

### Removal/installation of wire wheel

**1**  
Detach the steering wires' rear attachment (1) .

**2**  
Remove the screw (12) and detach the wire wheel (11).

**3**  
Remove the bearing's circlip (13) and knock out the bearing (14).

**4**  
To install the wire wheel, the reverse order is applied.

After installation, check the wire tension (see page 17).

For Rider 1030 Bioclip and Rider 1200, there is a complete set (attachment, wire wheel, bushing, bearing) to assemble, article no. 506 50 09-01. For Rider 850 and Rider 970, the parts are ordered separately.

## Checking and adjusting brake wire

### Checking and adjusting Rider 850/970

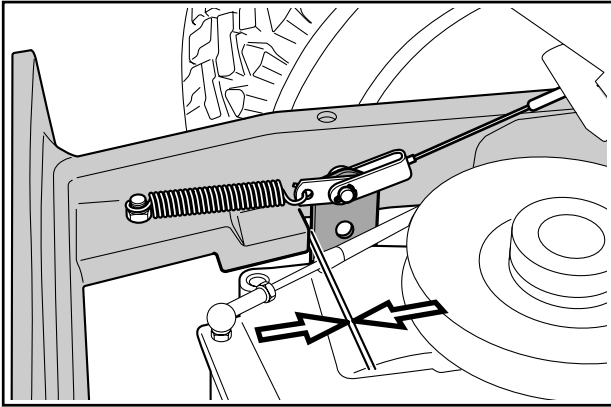

Check that the brake is correctly adjusted by measuring the distance between the brake lever and the front edge of the recess on the chassis. The distance should be 0–1 mm when the brake is not applied.

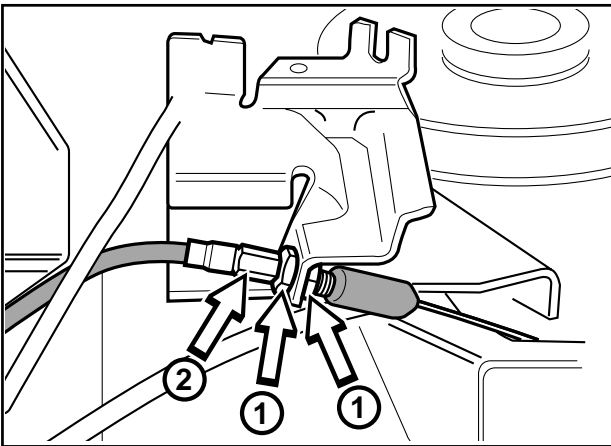

**1**  
Remove the lock nuts (1).

**2**  
Stretch the wire with the adjuster screw (2) so that the distance between the brake lever and the front edge of the recess on the chassis is 1 mm.

**3**  
Tighten the lock nuts (1) after adjustment.

When the brake wire has been adjusted, check that the brake lever does not have too much movement. If the lever's free movement exceeds 9 mm, this should be adjusted by tightening the nut on the brake lever.

## Checking and adjusting Rider 1030 Bioclip/1200

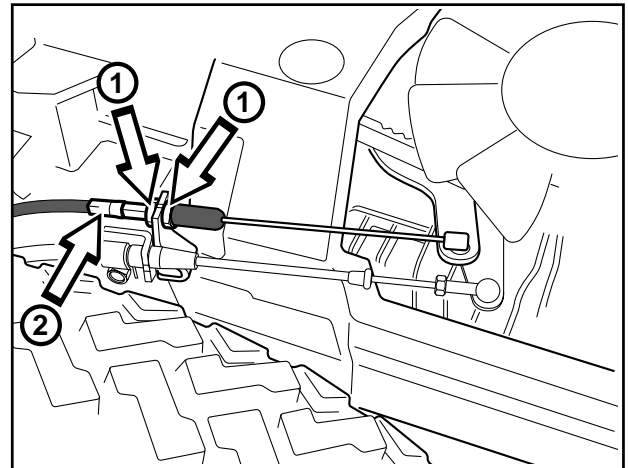

Check that the brake is correctly adjusted by positioning the ride-on mower on a gentle slope and applying the brake. If the ride-on mower does not stand still, the brake needs to be adjusted.

The brake is adjusted in the following way:

- 1**  
Release the lock nuts (1).
- 2**  
Stretch the wire with the adjuster screw (2) until all the play in the wire disappears.
- 3**  
Tighten the lock nuts (1) and finally check that the brake is correctly adjusted.



### **WARNING!**

**A badly adjusted brake can lead to reduced braking capacity.**

## Checking and adjusting gear control Rider 850/970

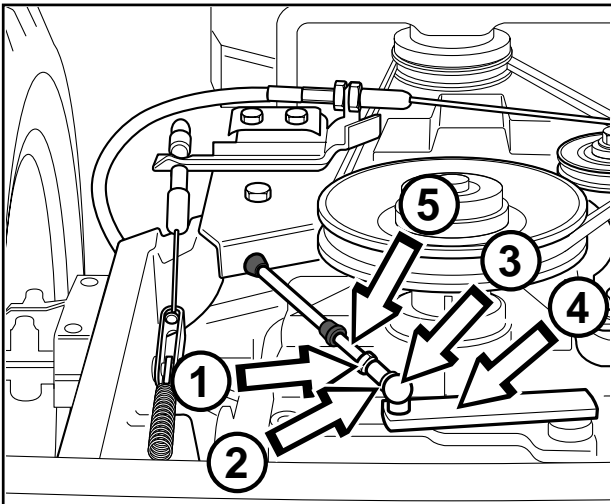

Check the gear control adjustment by setting the gear change lever to the "N" position. When the lever (4) goes easily into the neutral position, the control is correctly adjusted. In other cases, the control is adjusted in the following way:

- 1 Detach the lock nut (1) on the ball joint.
- 2 Press the locking spring (2) backwards so that the spherical socket (3) can be lifted away from the pivot on the lever (4).
- 3 Adjust the spherical socket (3) position on the connecting rod (5) until the right adjustment is obtained.
- 4 Lock the setting with the lock nut (1) and press the locking spring (2) into position.

## Checking and adjusting throttle control Rider 1030/1200

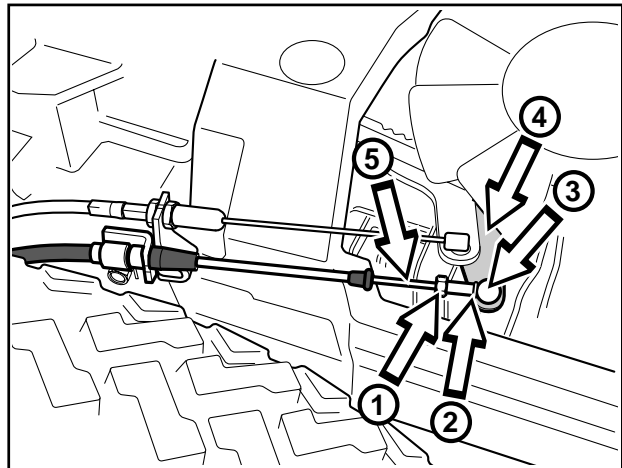

- 1 Detach the locking nut (1) on the ball joint.
- 2 Press the locking spring (2) backwards so that the spherical socket (3) can be lifted away from the pivot on the lever (4).
- 3 Press the throttle pedal to the bottom and move the lever (4) forwards as far as it goes using a screwdriver.
- 4 Adjust the spherical socket (3) position on the connecting rod (5) so that it just passes over the pivot on the lever.
- 5 Lock the setting with the lock nut (1) and press the locking spring (2) into position.

### IMPORTANT INFORMATION

Check that the locking spring goes through the hole in the spherical socket.

## Checking and adjusting freewheel clutch Rider 850/970

1

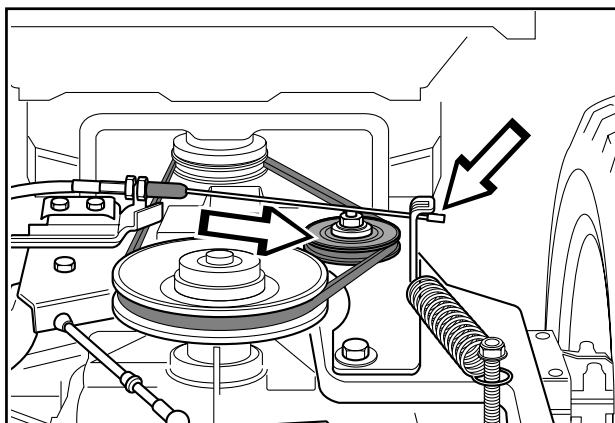

The freewheel clutch is correctly adjusted when the tensioning wheel's outward movement is stopped by the belt and not by the wire.

2

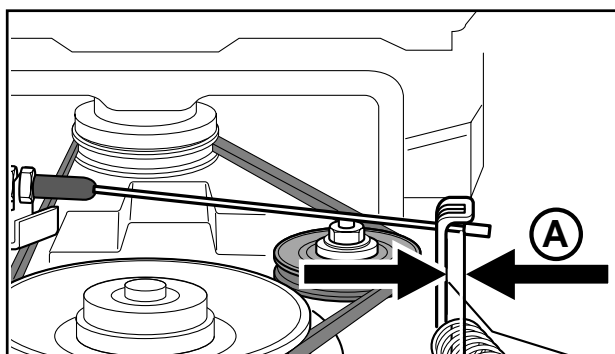

There should be a play (A) of 8-10 mm between the wire nipple and the lever.

3

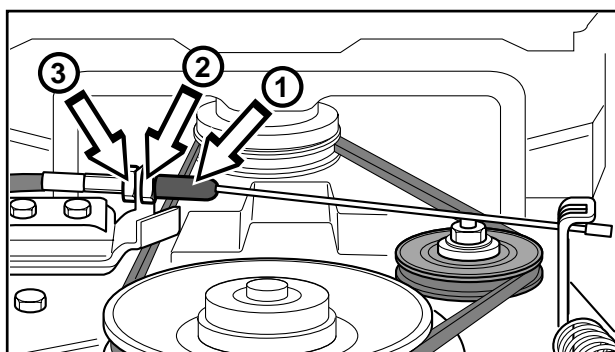

Adjust the freewheel clutch wire as follows:

- Pull off the rubber sleeve (1). Loosen the nuts (2) and stretch the wire with the adjuster screw (3).
- Tighten the lock nuts (2) after adjustment.

## Replacing articulated steering bearing

1

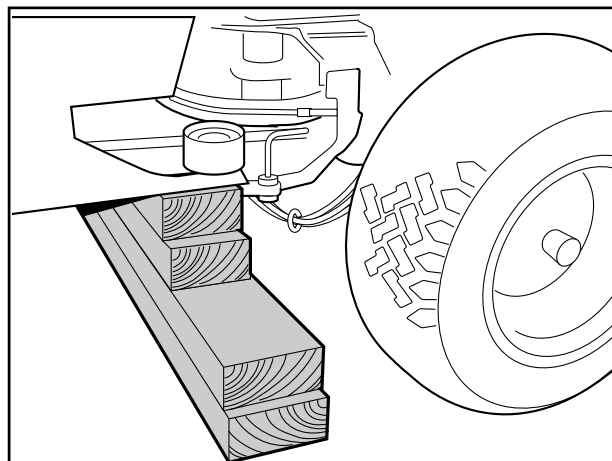

- Remove the engine according to the earlier description (see page 12).
- Block up the ride-on mower in front of the articulated steering.

2

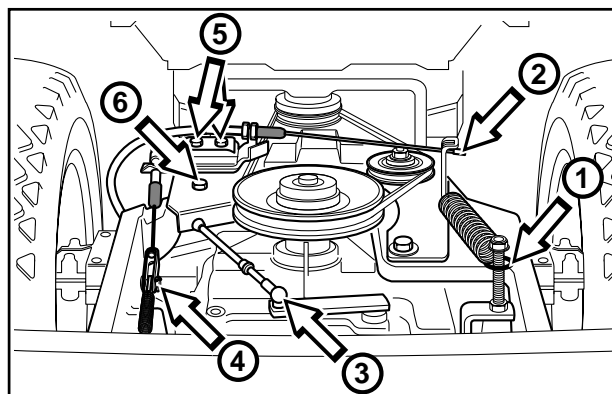

- Release the tensioning wheel spring (1).
- Release the clutch, gear and brake wire (2, 3 and 4) and remove the wires' holder plates (5 and 6).

3

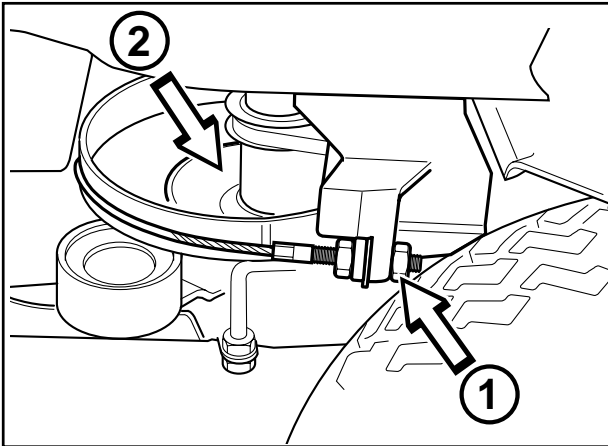

- Loosen the steering wires (1) and remove the steering rim.
- Remove the pulley (2). Move the lower part forwards, the upper part backwards and detach the pulley.

5

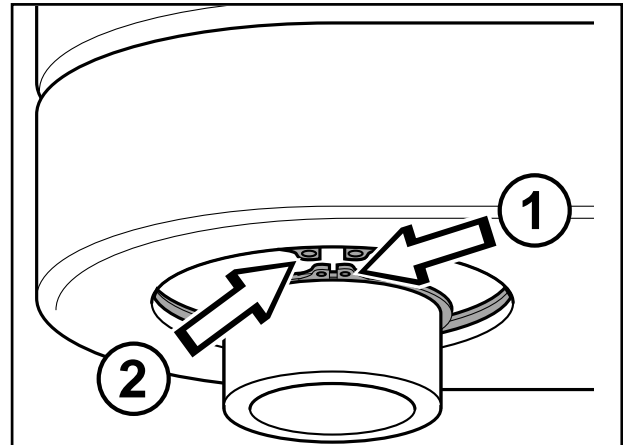

Remove the inner circlip (1) from the lower bearing (see diagram). The rear section is now loose and can be moved. Then detach the outer circlip (2) and take the bearing out downwards.

4

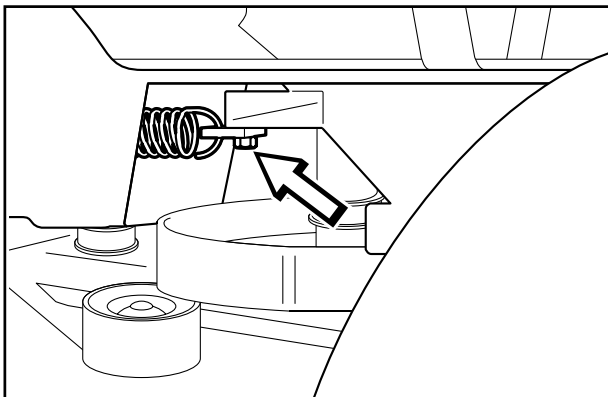

Detach the articulation spring. This spring is strongly tensioned and should be secured with tool no. 506 89 93-01 before the nut is removed.



**WARNING!**  
The articulation spring is strongly tensioned and can cause injury if it flies off. Wear safety glasses and gloves when removing/attaching the spring.

6

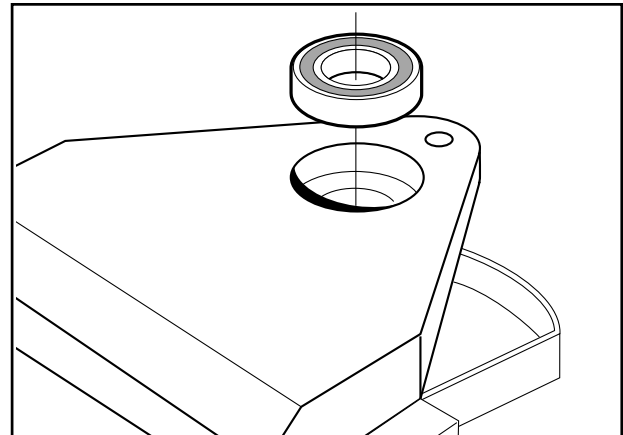

- Take the upper bearing out upwards, if it does not come out easily, it should be knocked out from below.
- Insert the new bearings and assemble the articulated steering in the reverse removal order.
- After re-assembly, the wire tension should be checked (see page 17). Also check that the controls and wires are correctly adjusted (see pp. 20–22).



## Removal of swing axle

1

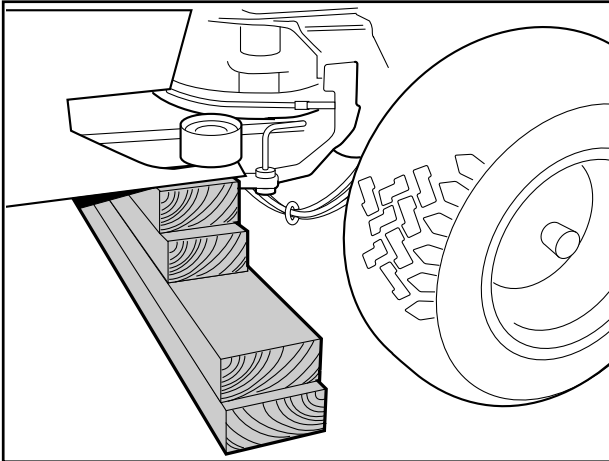

- Block-up the machine in front of the rear frame.
- Remove the transmission/gear box cover.

3

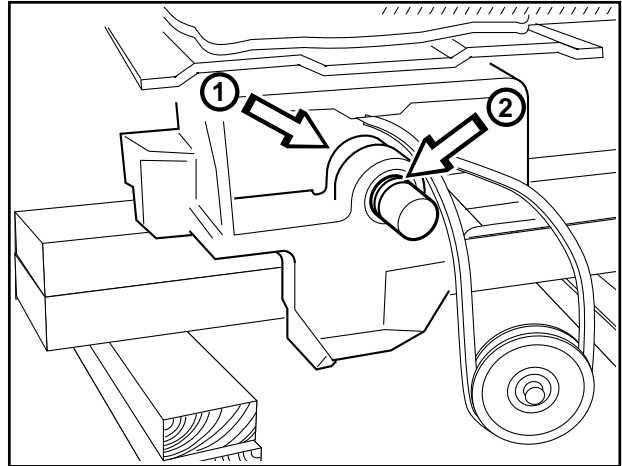

Remove the circlip and washer from the swing axle's inner holder (1) and pull the swing axle out backwards.

If the dust protection (2) is damaged, this should be replaced by a new one.

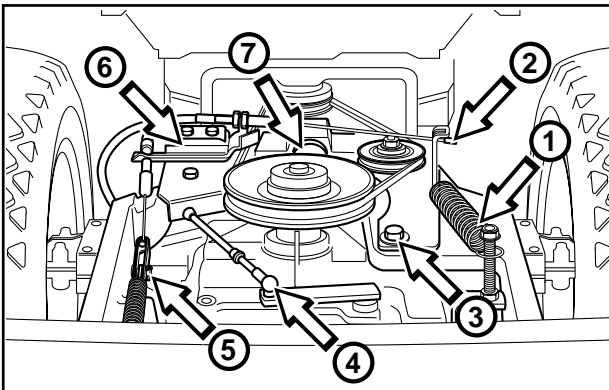

- Detach the tensioning wheel spring (1) and the clutch wire (2).
- Disconnect the tensioning wheel arm (3) from the rear frame, and detach the belt from the gear box pulley.
- Detach the gear and brake wires (4 and 5) and remove the wires' holding plates (6).
- Remove the circlip and washer from the swing axle (7) and pull the rear frame out backwards.

## Installation of swing axle

1

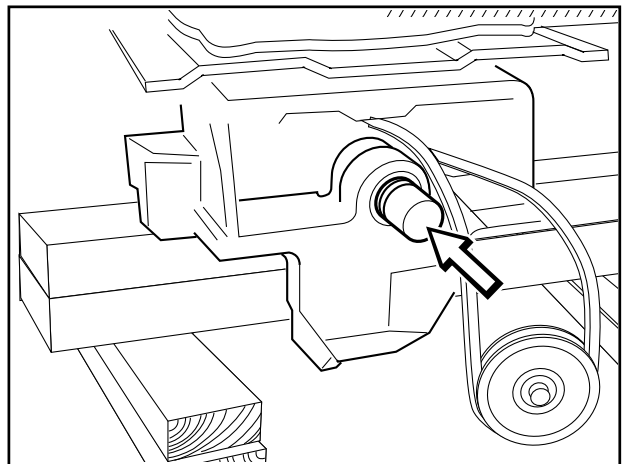

- Grease half of the axle (the half without turn down) and press it from the back into the steering spindle (see diagram).
- Attach the washer and circlip on the swing axle's inner holder.
- Fix the dust guard (with a thin lip behind) approx. 2/3 of the way in on the axle and lubricate the axle on both sides of the dust guard.

2

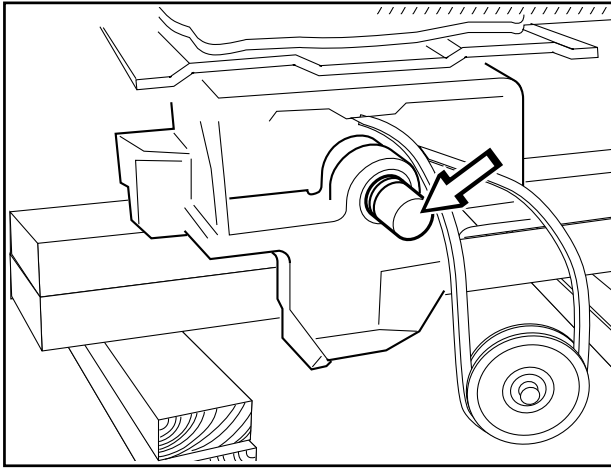

Roll the rear frame forwards and press it in on the swing axle.

4

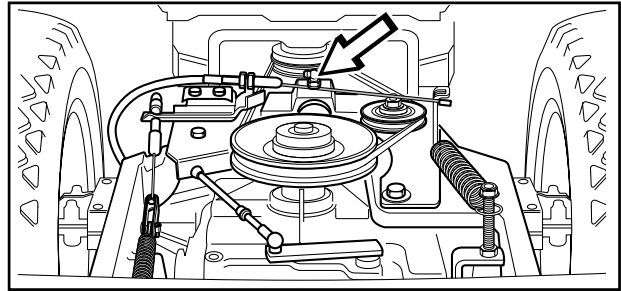

After installation of the swing axle, lubricate the lubricating area above the swing axle housing with molybdenum disulphide grease. Also check that the wires and controls are correctly adjusted justerade (see page 20–22). Finally, attach the transmission/gear box cover.

3

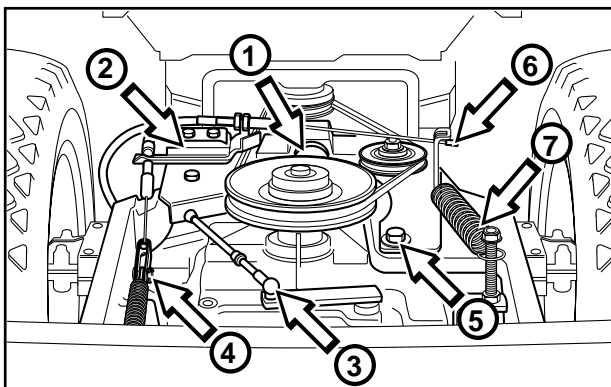

- Attach a washer and circlip onto the swing axle (1).
- Firmly secure the wires' holder plates (2), as well as the gear and brake wires (3 and 4).
- Connect the belt onto the pulley and tightly screw the tensioning wheel arm (5) onto the rear frame.
- Attach the clutch wire (6) and the tensioning wheel spring (7).

## Removal/installation of gear box

1

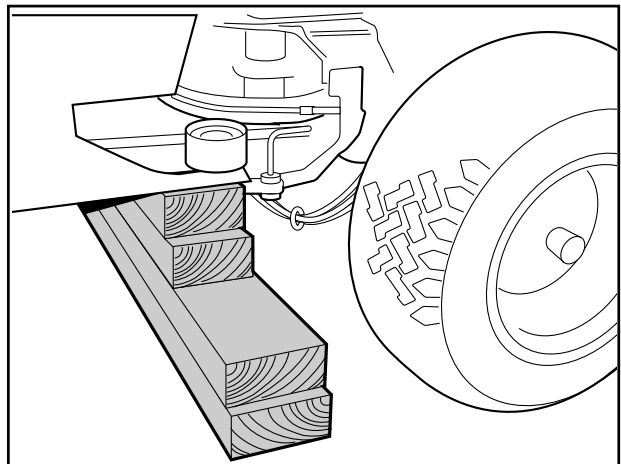

- Block-up the machine in front of the rear frame and dismantle the rear wheels.
- Remove the cover from over the gear box.

2

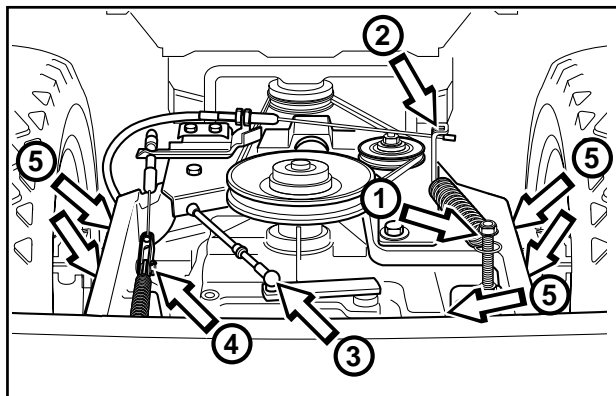

- Release the tensioning wheel spring (1).
- Unfasten the clutch wire (2), and detach the belt from the gear box pulley.
- Detach the gear and brake wires (3 and 4).
- Insert a garage jack under the gear box and unscrew the gear box's five holder screws (5).

3

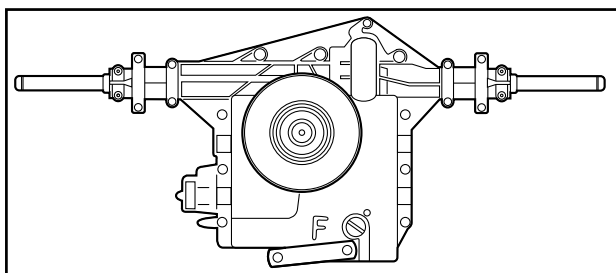

- Lower the garage jack and pull out the gear box.
- Installation of the gear box is carried out in the reverse removing gear box order
- After installation, check that the clutch, brake and gear wires are correctly adjusted (see pp. 20–22).

## Removing/installation of hydrostatic transmission Rider 850 HST, Rider 970 HST

1

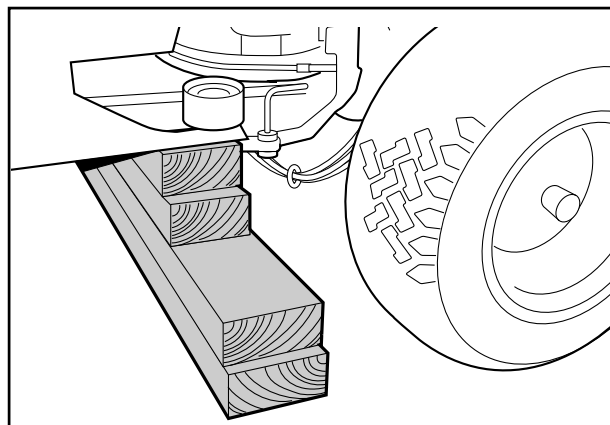

- Block-up the machine in front of the rear frame and remove the back wheels.
- Remove the transmission cover.

2

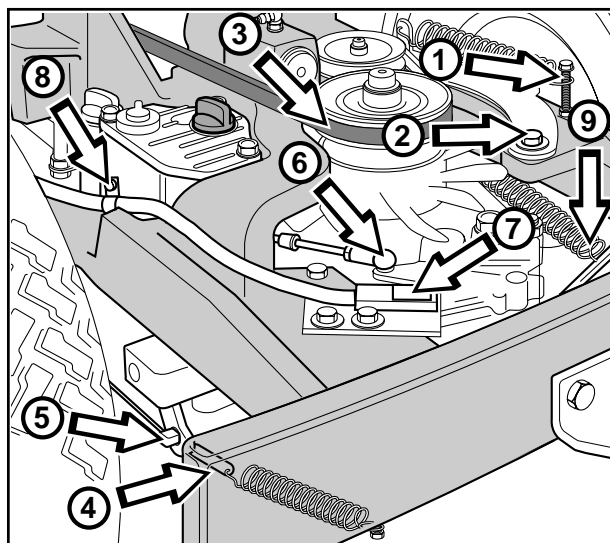

- Release the tensioning wheel spring (1) and remove the tensioning wheel arm (2).
- Detatch the drive belt (3).
- Release the brake wire spring (4) and remove the brake wire from the brake lever (5).
- Dismantle the throttle control (6) and disconnect the hydrostatic transmission breaker cable (7).
- Release the clamp which holds the throttle wire and the cable (8) and lay the wire and cable to one side.
- Release the disengaged clutch control spring (9).

3

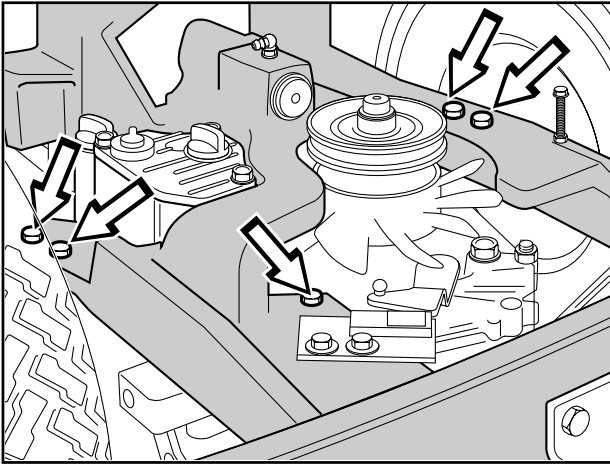

Insert a garage jack under the hydrostatic transmission and loosen its five holder screws.

## Removing/installation of hydrostatic transmission Rider 1030, Rider 1200

1

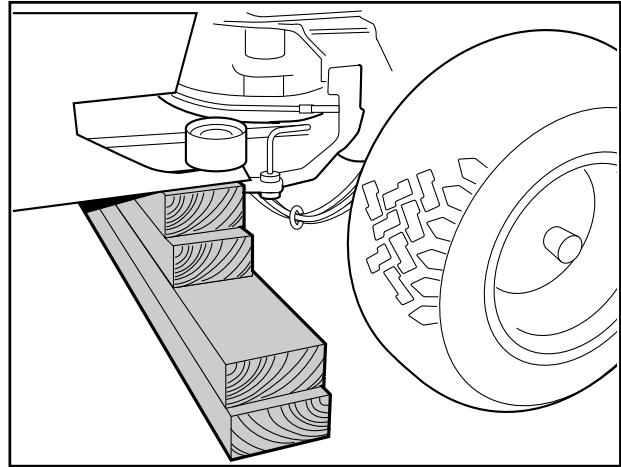

- Block-up the machine in front of the rear frame and remove the back wheels.
- Remove the transmission cover.

4

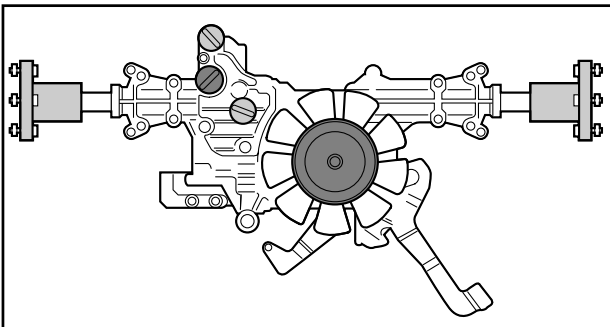

- Lower the garage jack and pull out the hydrostatic transmission.
- Installation of the hydrostatic transmission is carried out in the reverse hydrostatic transmission removing order
- After installation, check that the brake wire and throttle control are correctly adjusted (see pp. 20–22). Also check the oil level in the hydrostatic transmission and refill as is necessary.

2

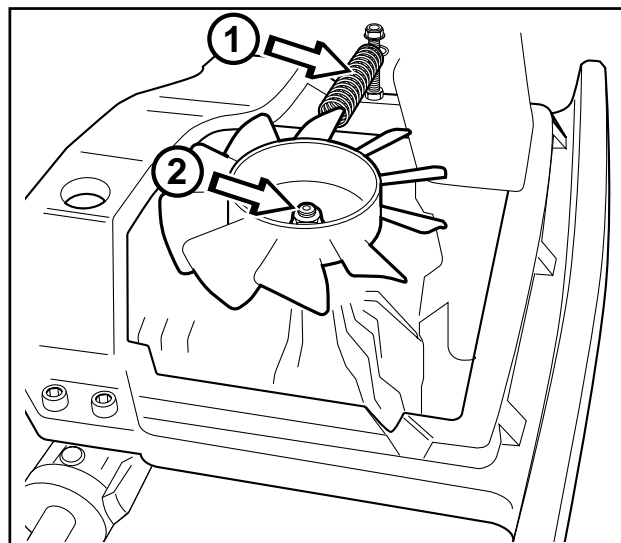

- Release the tensioning wheel spring (1).
- Remove the circlip (2), lift away the washer and fan from the ingoing axle.

3

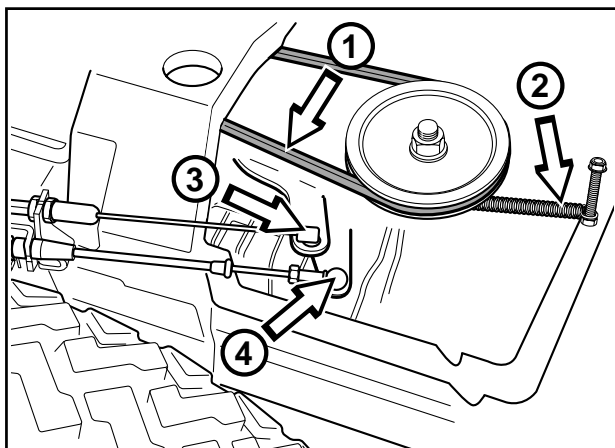

- Detach the drive belt (1) and release the brake wire spring (2).
- Disconnect the brake wire (3) and dismantle the throttle control (4).
- Remove the spring (5) and the disengaged clutch control (6).

5

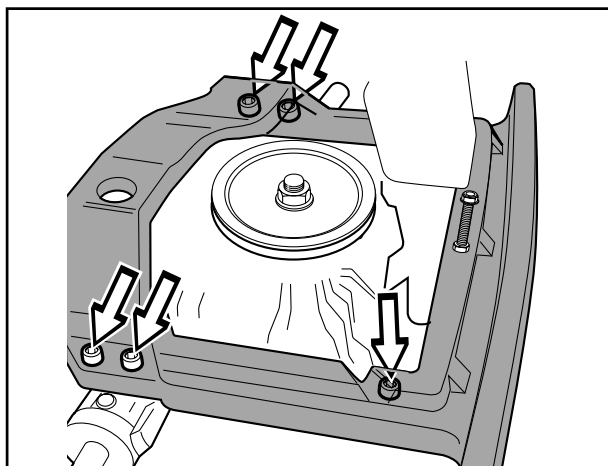

Insert a garage jack under the hydrostatic transmission and loosen its five holder screws.

4

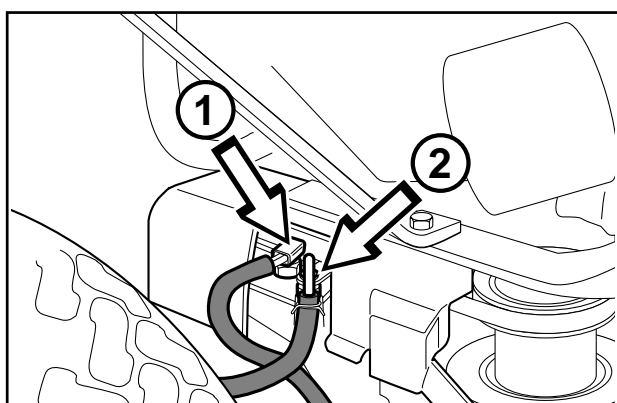

Disconnect the contact (1) and take off the hose (2). Ensure that the oil does not run out, e.g. tie up the hose higher than the oil level in the container.

6

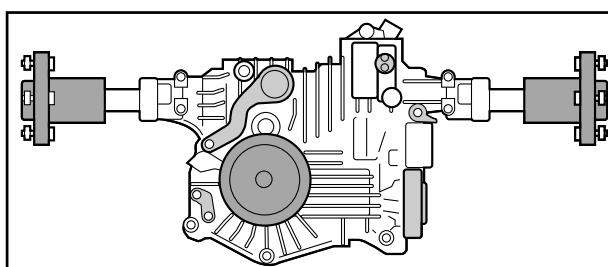

- Lower the garage jack and pull out the hydrostatic transmission.
- Installation of the hydrostatic transmission is carried out in the reverse hydrostatic transmission removing order
- After installation, check that the brake wire and throttle control are correctly adjusted (see pp. 20–22). Also check the oil level in the container and refill as is necessary.

## Replacing hydrostatic transmission axle sealing collars

1

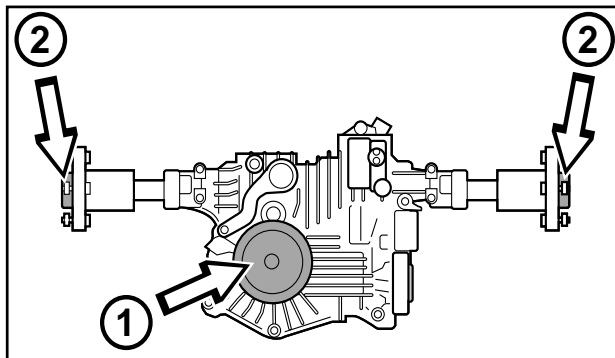

Take the hydrostatic transmission out of the ride-on mower, as indicated in previous description (see page 26).

Remove the pulley (1) from the ingoing axle by pulling it upwards. Then dismantle the circlip under the pulley.

2

Dismantle the circlips which hold the wheel hubs (2) at the axles and remove the hubs by pulling them outwards. Do not lose the key which sits between the hub and the axle.

### Sealing collar replacement - ingoing axle

1

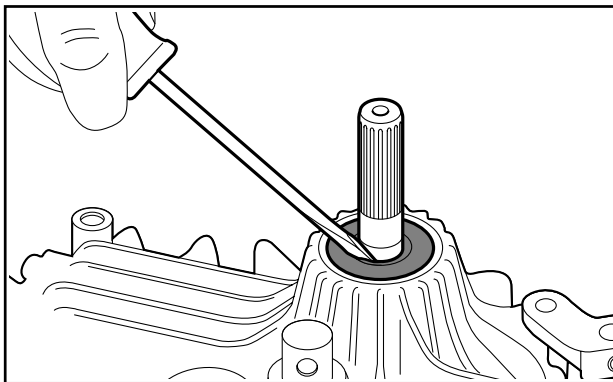

- Clean the ingoing axle and the area around the sealing collar of all dirt and rust.
- Insert a screwdriver between the sealing collar and the axle and bend the sealing collar out of the axle housing with a twisting motion.

#### IMPORTANT INFORMATION

The area around the sealing collar must be absolutely clean! If the hydrostatic oil is contaminated with dirt, this can lead to a shorter hydrostatic transmission operational life.

2

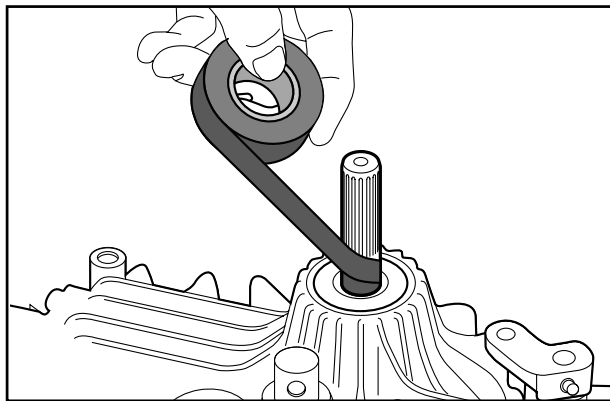

- Wrap insulation tape around the ingoing axle to protect the new sealing collar from damage to splines and grooves. Start by wrapping from the bottom and continue upwards over the axle until the entire axle is wrapped in tape.
- Lubricate the axle and the inside of the new sealing collar with grease so that the collar can slide easily.

3

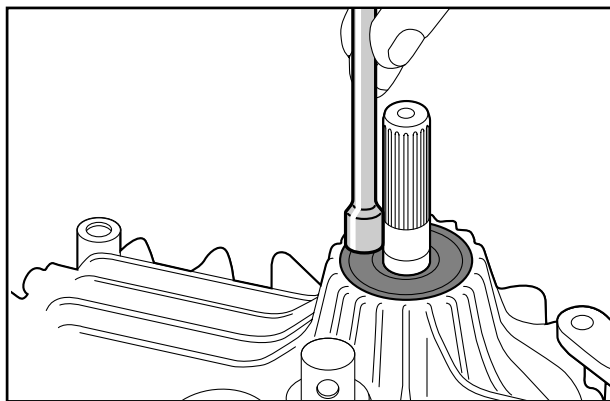

- Place the sealing collar on the axle with the smooth side upwards, and *carefully* press it downwards.
- Use the thick end of a 1/4" extender to *carefully* knock down the sealing collar until the upside of the collar is level with the axle housing's upper edge. Move the extender in a circle around the sealing collar so that it is evenly pressed down, all the way around.
- Remove the insulation tape from the axle and assemble the lower circlip and the pulley with the hexagonal hub facing upwards.
- Fasten the fan and the washer and assemble the upper circlip.
- Install the hydrostatic transmission in the ride-on mower as indicated in the previous description (see page 26).

## Sealing collar replacement - outgoing axles

1

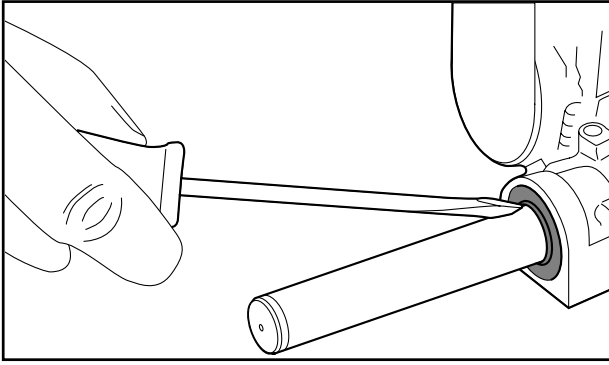

- Clean the outgoing axle and the area around the sealing collar of all dirt and rust.
- Insert a screwdriver between the sealing collar and the axle and bend the sealing collar out of the axle housing with a twisting motion.

### IMPORTANT INFORMATION

Dirt must not be allowed to get into the transmission as this can shorten its operational life.

2

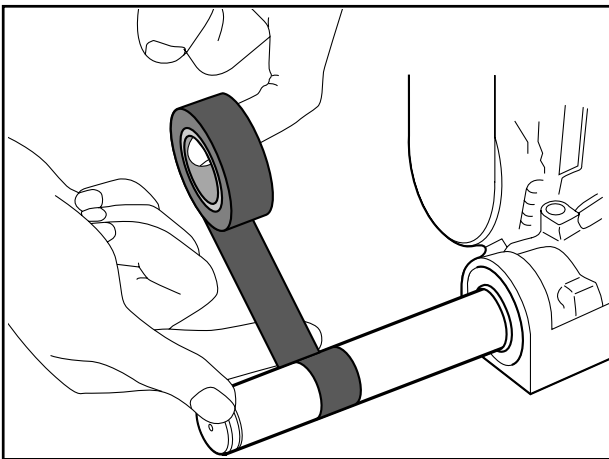

- Wrap insulation tape around the outgoing axle from the start of the key-way and outwards until even the circlip's groove is covered with tape. This is done to protect the new sealing collar from damage.
- Lubricate the axle and the inside of the new sealing collar with grease so that the collar can slide easily.

3

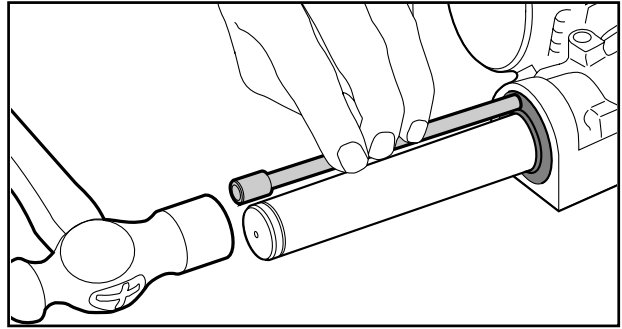

- Place the sealing collar on the axle, with the metal spring inwards, and press it in *carefully*.

### IMPORTANT INFORMATION

Before the sealing collar is completely installed, check that the sealing collar's metal spring reinforcement sits on the side of the sealing collar which leads inwards towards the transmission.

- Use the narrow end of a 1/4" extender to *carefully* knock in the sealing collar until it reaches the bottom of the axle housing. Only knock on the steel cover. Move the extender in a circle around the sealing collar so that it is pressed in evenly all the way around and tight against the axle.
- Remove the insulation tape from the axle and repeat, as is necessary, the entire procedure for the second axle.
- Install the hydrostatic transmission in the ride-on mower as indicated in the previous description (see page 26).

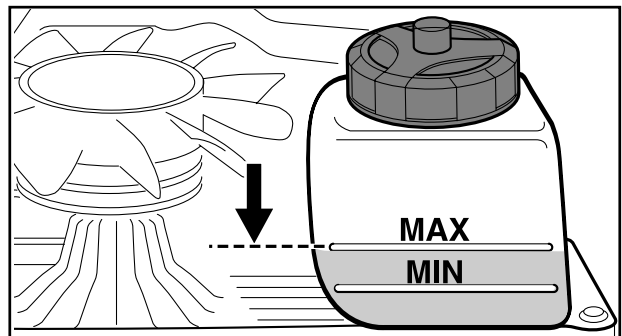

- Fill the transmission's oil container with SAE 10W30 oil until the oil level reaches the "MAX"-marking.
- Operate the ride-on mower and then check that there is no oil leaking from the new axle sealing collars.

## Hydrostatic transmission brake

### Removal of brake

1

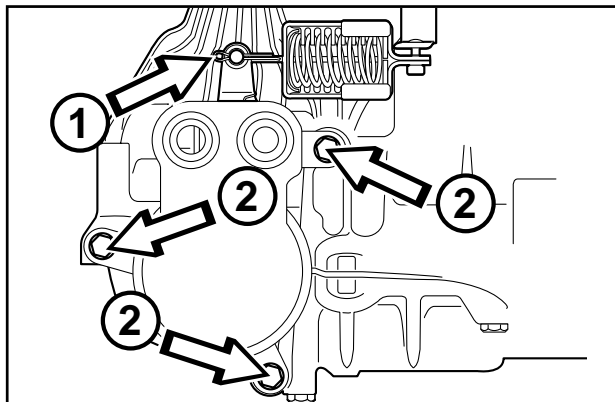

- Place blocks in front of and behind the wheels so that the ride-on mower can not roll. Then, release the parking brake.
- Remove the split pin and the washer from the brake's connecting rod (1).
- Remove the three bolts and washers (2) from the transmission and detach the brake lining packet.

2

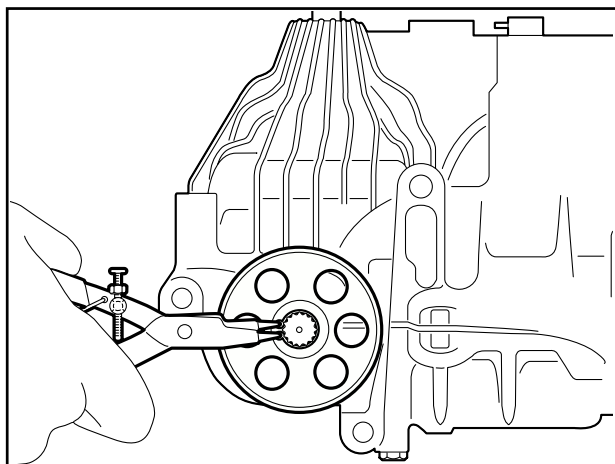

Remove the brake drum by removing the circlip and pulling the drum outwards.

#### IMPORTANT INFORMATION

It is seldom necessary to remove the brake drum. If, however, it needs to be removed, a puller and/or penetrating oil is needed to get it off.

### Installation of brake

1

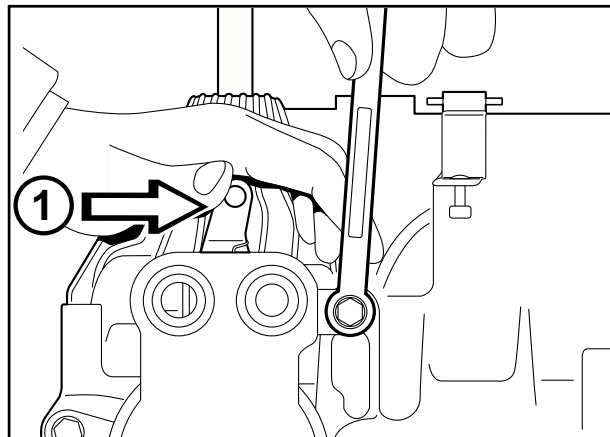

- Put the brake drum on the axle and attach the circlip.
- Assemble the brake lining packet on the transmission and tighten the three bolts and washers *by hand*.
- Press the brake lever (1) backwards so that the brake lining locks the drum, and draw the three bolts with moment to 27 Nm (20 ft. lbs.), whilst the drum is locked.

2

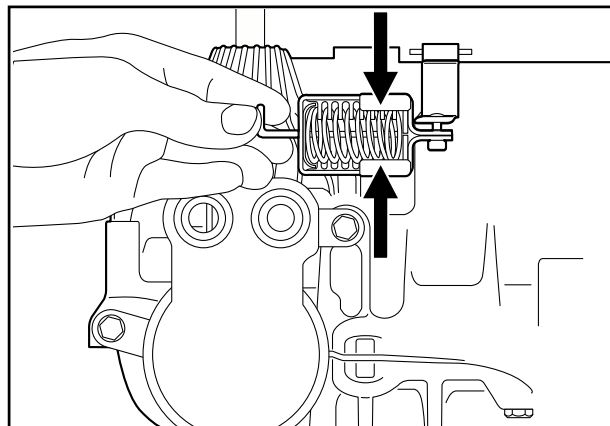

Install the brake spring with holder on the gold-coloured brake arm by passing the recesses into the holder with metal tabs on the brake arm. Then, turn the holder in towards the transmission.

#### IMPORTANT INFORMATION

Firmly fix the spring holder so that the holder's metal tabs (shown by the arrows) point away from the transmission.



3

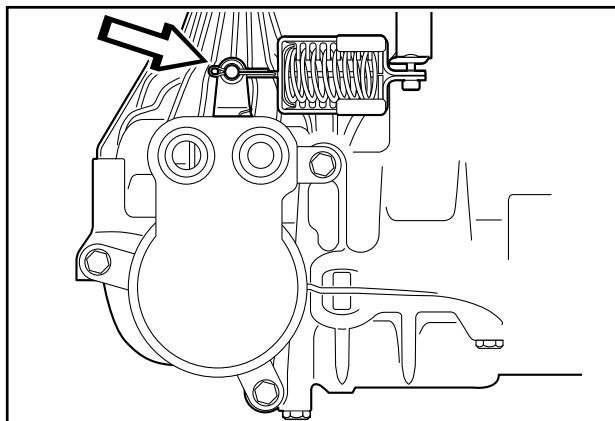

- Firmly attach the brake's connecting rod in the hole on the brake lever and assemble the washer and spring clip.
- Remove the blocks in front of and behind the wheels and continue with "Adjusting brake".

2

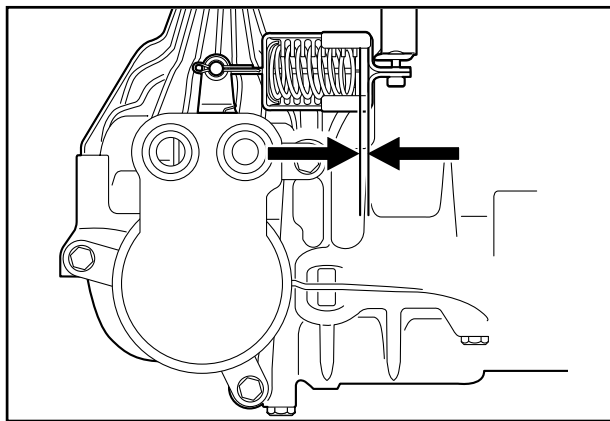

When the parking brake is fully applied, the gap between the spring and the spring holder attachment (see diagram) should be 4–8 mm.

### IMPORTANT INFORMATION

Firmly attach the connecting rod so that the washer and the spring clip are on the outside of the brake lever (see diagram).

### Adjustment of brake

1

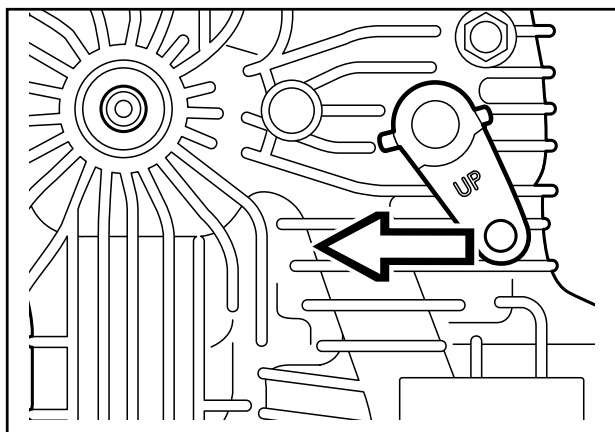

Apply the parking brake and check that the transmission's brake arm is pulled as far forwards as possible (see diagram). Adjust this with the brake wire tensioning screw.

3

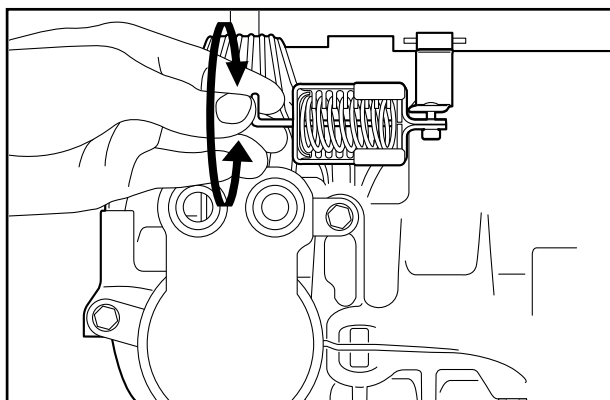

Adjust the gap by:

- Releasing the parking brake.
- Loosening the connecting rod by removing the spring clip and the washer.
- Turning the connecting rod in or out of the spring (see diagram) to adjust the gap.
- Firmly attach the brake's connecting rod in the hole on the brake lever and assemble the washer and spring clip. Make sure that the washer and spring clip are on the outside of the brake lever.
- Apply the parking brake and check the gap once again.
- Repeat the adjustment procedure until the correct gap is obtained.

## Bleeding the hydrostatic transmission oil system

1

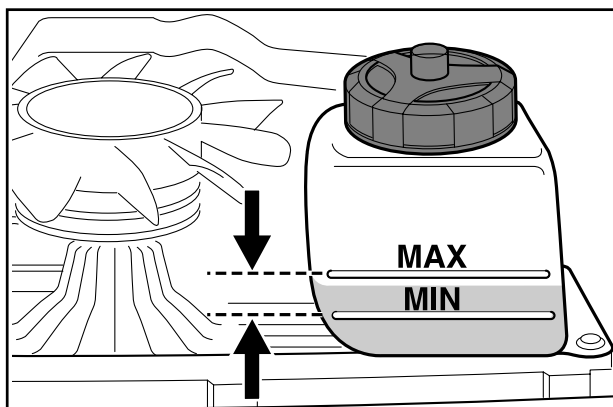

- Check the hydrostatic transmission oil level.
- Start the engine and set the throttle control to low idle.

2

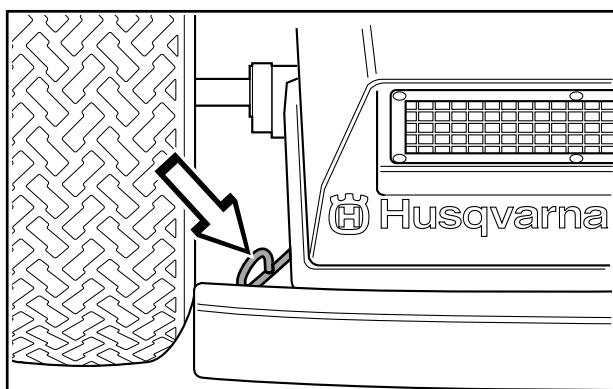

- Repeat opening and closing the disengaged clutch control whilst the front respective rear pedals are alternately pressed down.
- When the ride-on mower starts to move, the governor control lever should be increased to high idle.

3

- Repeat quick starts and emergency stops until the transmission responds as it should.
- Finally, check the hydrostatic transmission oil level and fill as is required.

4

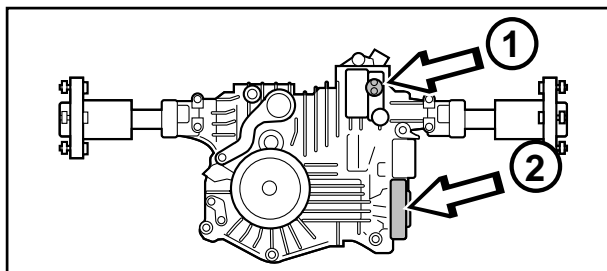

For immediate bleeding of the oil system, fill new oil directly into the transmission (1) and, at the same time, pull the pump round by hand with the brake drum (2).

## Adjustment of transmission neutral position

1

Bleed the hydrostatic transmission oil system.

2

Lift the back of the ride-on mower up so that the wheels are off the ground and place blocks under the machine.

3

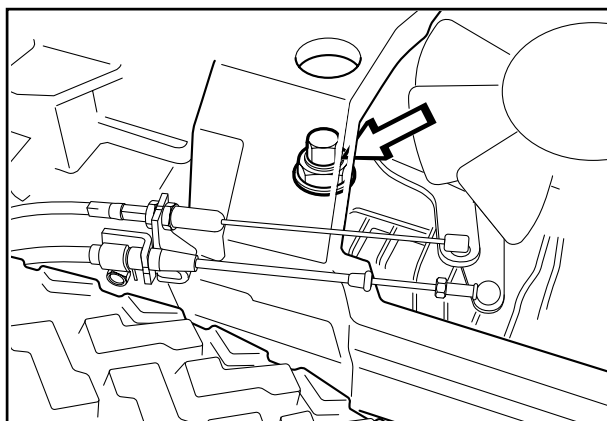

- The neutral position is adjusted by turning the hexagonal axle on the transmission (see diagram).
- Start the engine and set the throttle control to full throttle.
- Unscrew the hexagonal axle lock nut and turn the axle clockwise until the drive shafts start to rotate backwards.
- Make a mark on the top of the axle.

4

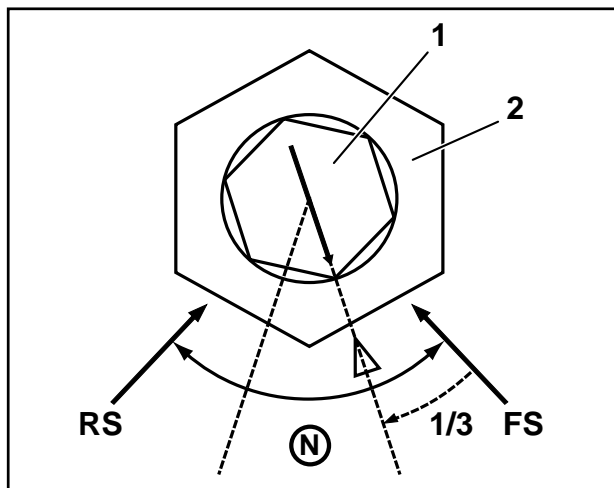

1 = Axle  
2 = Lock nut

- Slowly turn the axle anti-clockwise until the drive shafts stop rotating backwards and make a mark on the transmission housing (RS).
- Slowly turn the axle anti-clockwise until the drive shafts start to rotate forwards.
- Slowly turn the axle clockwise until the drive shafts stop rotating forwards and make a mark on the transmission housing (FS).
- Turn the axle clockwise 1/3 of the distance between the marked stop points.
- Hold the axle (M8) firmly and tighten the lock nut (M17).
- Check that the drive shafts do not rotate in the neutral position by slowly transferring the steering arm to the neutral position from the forwards and reverse positions.

5

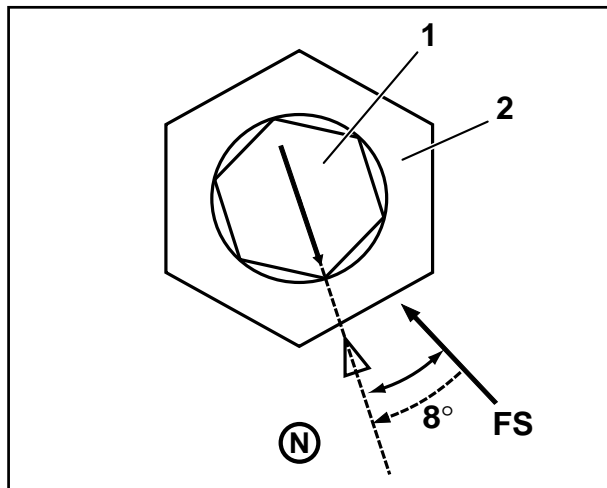

1 = Axle  
2 = Lock nut

If the drive shafts do not rotate backwards despite the hexagonal axle having rotated a full turn, the neutral position is to be adjusted in the following way:

- Slowly turn the axle anti-clockwise until the drive shafts start to rotate forwards.
- Slowly turn the axle clockwise until the drive shafts stop rotating forwards and make a mark on the transmission housing (FS) and the axle.
- Turn the axle clockwise 8° from the mark on the transmission housing.
- Hold the axle (M8) firmly and tighten the lock nut (M17).

## Transmission maintenance

### Oil change

Most garden owners do not have tools for or experience of changing transmission oil. The transmission probably has a longer operational life than other ride-on mower components, this makes transmission oil changes less important for most customers. However, the transmission's operational life is increased if oil changes are made.

If the ride-on mower is used *professionally*, it is recommended to change the oil firstly after 50 hours use and every 200 hours use thereafter.

The oil filter only needs to be changed if the transmission is opened for repairs to be made.

The transmission holds 3.3 litres SAE10W/30 engine oil, class CD-SF.

### Ineffective brake power

As the brake is only used as a parking brake, wear is negligible. If the brake power is nevertheless ineffective, this can be adjusted:

- Release the three bolts (N12) which hold the brake lining packet.
- Press on the brake lever so that the brake lining centres itself around the brake drum and tighten the three bolts with moment (27 Nm).

## Checking and adjusting mower deck ground pressure Rider 970/1030 Bioclip/1200

1

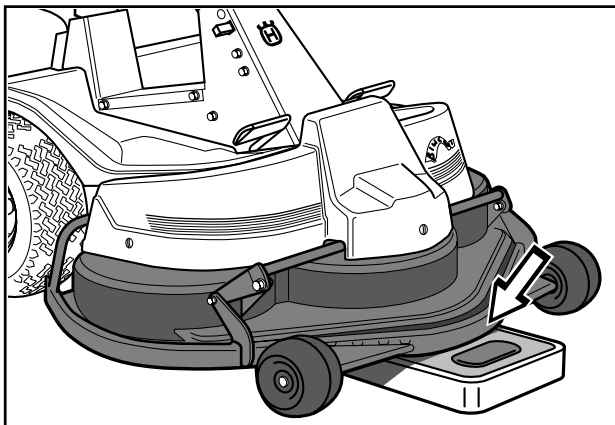

Place a set of bathroom scales under the mower deck's frame (front edge) so that the deck rests on the scales.

2

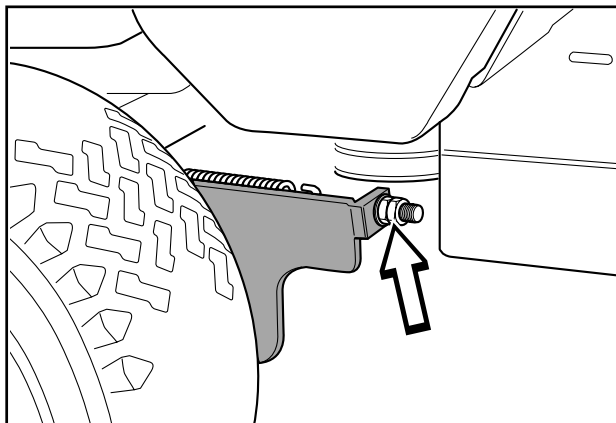

Adjust the mowing deck's ground pressure with the adjuster nuts placed behind the front wheels on both sides of the ride-on mower. The ground pressure should be between 12 and 15 kg.

## Checking and adjusting mower deck parallelism

1

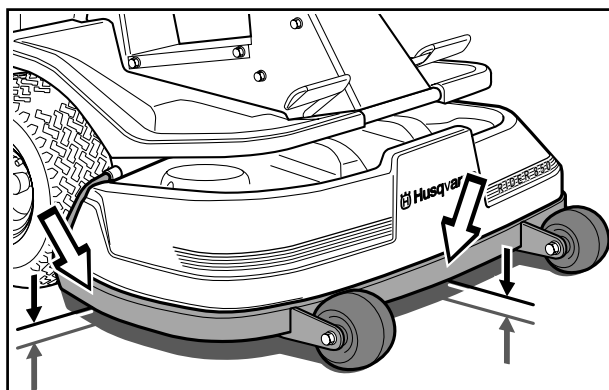

Place the ride-on mower on an even surface and measure the distance between the ground and the edge of the deck, at the front and rear of the cover. If the values correspond, the deck is parallel.

2

### Adjusting Rider 1030 Bioclip/1200

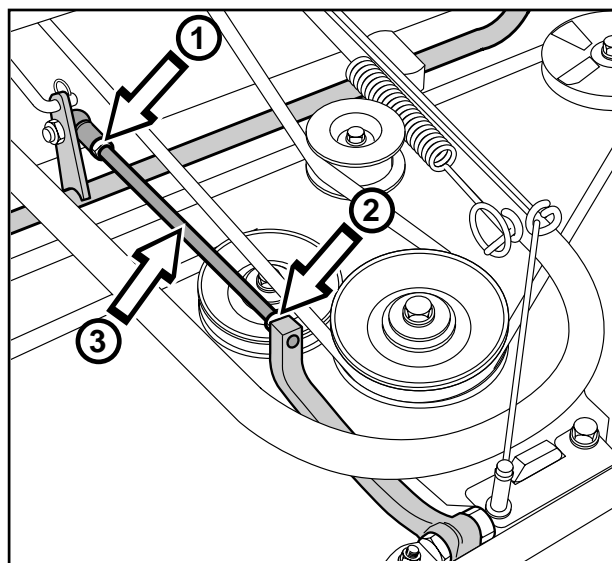

- Remove the front cover, as well as the right and left fenders.
- Unscrew the lock nuts (1) and (2). Note that the ends of the strut are right respective left-handed.
- Place a key over the chamfering (3) in the middle of the strut and screw the strut forwards or backwards to raise or lower the front edge of the cover.
- Tighten the lock nuts after adjustment.
- After adjustment, the deck's parallelism is to be checked. Thereafter, re-attach the front cover as well as the right and left fenders.

2

### Adjusting Rider 850

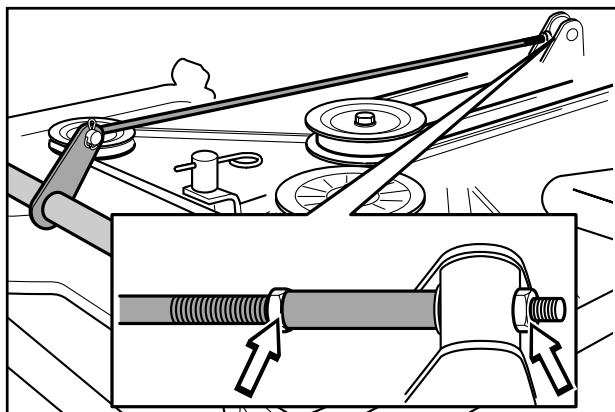

- Remove the front cover and the right-hand fender.
- Vertical adjustment of the mowing deck is made with the adjuster nuts on the back edge of the lift-strut.
- Raise the mowing deck at the front edge by shortening the lift-strut. Lower the mowing deck at the front edge by lengthening the lift-strut.
- Tighten the nuts against each other after the adjustment.
- On completion of the adjustment, the deck's parallelism should be re-checked. Fit the right-hand fender and the front cover.

2

### Adjusting Rider 970

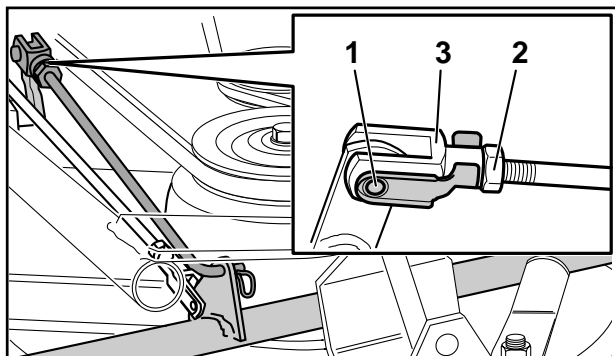

Rider 970 and older versions of Rider 1000, 1030 and 1200 are adjusted by screwing a fork on the parallel strut.

- Remove the front cover and the left and right-hand fenders.
- Release the strut by pulling out the rear pin (1). Lift the rear edge of the cover to relieve the parallel strut.
- Release the lock nut (2).

- Screw out the fork (3) to raise, or screw in the fork (3) to lower, the rear edge of the cover.
- Tighten the lock nut after adjustment (2).
- On completion of the adjustment, the deck's parallelism should be re-checked. Fit the right and left-hand fender, as well as the front cover.

### Adjusting cutting height area

1

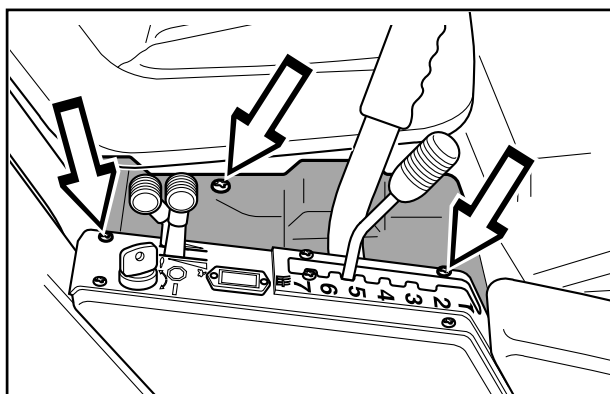

- On Rider 1030 Bioclip and Rider 1200, firstly remove the plastic cover on the right-hand side under the seat.
- On Rider 970 and Rider 850, firstly remove the right-hand fender.

2

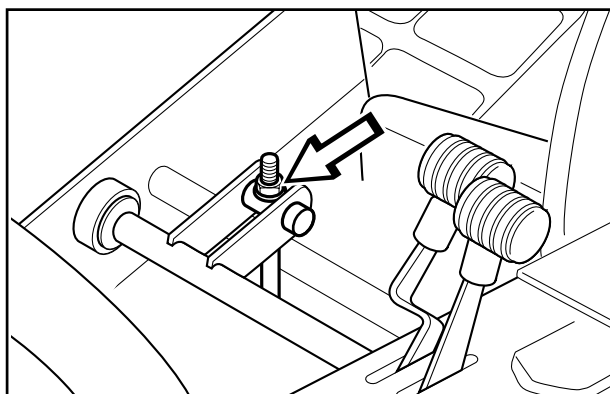

Raise or lower the entire mowing deck by screwing the nuts up or down. If, for example, the highest cutting height is raised by 5 mm, the other fixed cutting heights will also be raised by the same amount.

## Removal of mowing deck Rider 1030 and Rider 1200

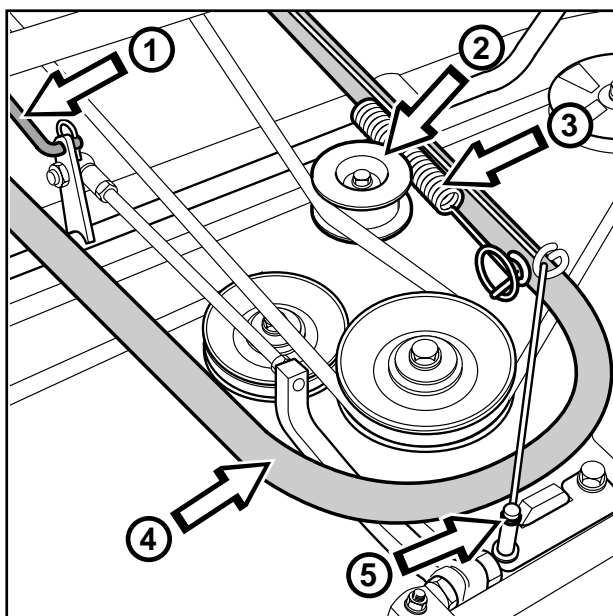

- 1 Remove the front cover. Set the cutting height to the lowest position.
- 2 Relieve the connecting rod (1). A breaking bar may be used, when the hair-needle spring is removed, to *carefully* bend the connecting rod out of its holder.
- 3 Release the tensioning wheel (2) by disconnecting the spring (3).
- 4 Bend the locking plate (5) forwards and press down the deck's front edge so that it is released from the deck frame (4).
- 5 Press the deck backwards and twist off the drive belt. Then pull the deck forwards so that the back end is released from the deck frame.
- 6 Installing the mowing deck takes place in the reverse order to removal.

## Removal of mowing deck Rider 970

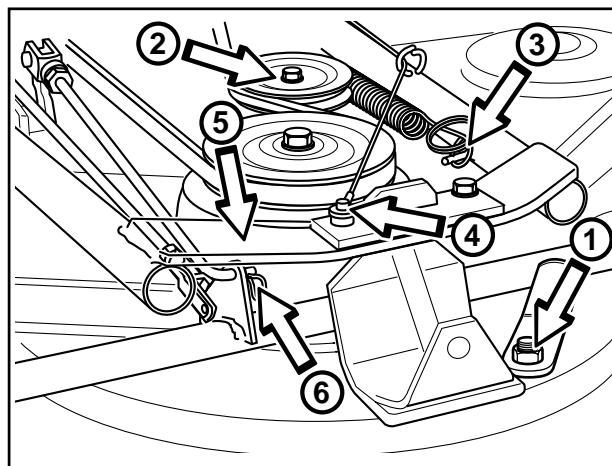

- 1 Remove the front cover.
- 2 Set the cutting height to the highest position. Push the stop (1) in against the crossbar and then set the cutting height to the lowest position. The mowing deck is now locked vertically.
- 3 Relieve the tensioning roller (2) by disconnecting the spring (3).
- 4 Bend the locking plate (5) forwards and press down the deck's front edge so that it is released from the deck frame (4).
- 5 Press the deck backwards and twist off the drive belt.
- 6 Remove the hair-needle spring and release the crossbar (6) from the height adjustment.
- 7 The deck can now be pulled forward until it releases from the rear suspension.
- 8 Installing the mowing deck takes place in the reverse order.



### WARNING!

When working on the mowing deck, wear protective glasses and gloves.

## Removal of mowing deck Rider 850

1

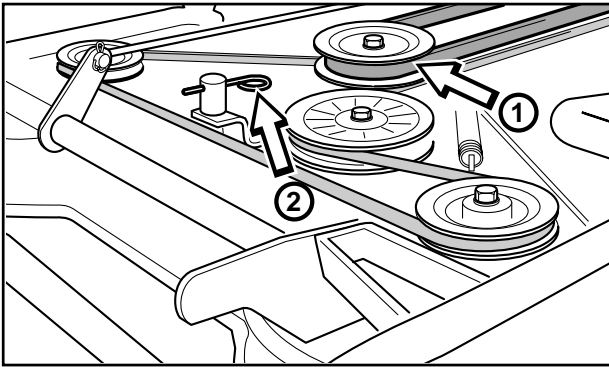

- Remove the front cover as well as the left and right-handed fender.
- Raise the mowing deck by pulling the lift lever backwards to the transport position.
- Dismantle the drive belt (1).
- Lower the mowing deck by pressing in the lift lever lock button and moving the lever to the cutting position.
- Set the lowest cutting height with the cutting height lever.
- Take the hair-needle spring (2) out of the chain retainer.

2

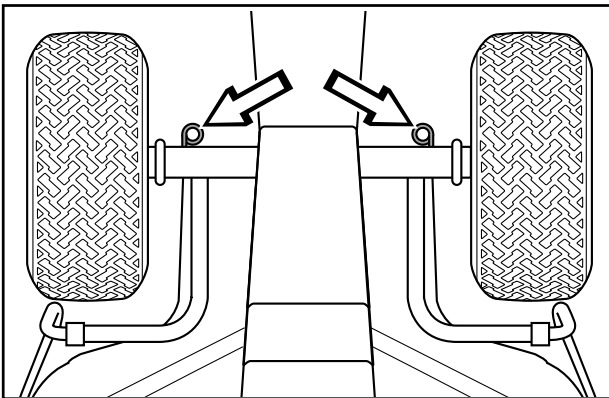

- Remove the lock pins (one on each side) on the rear edge of the unit.
- Installation of the mowing deck takes place in the reverse order.



### WARNING!

When the lock pins are removed, the deck will drop to the ground. Make sure to keep your hands or fingers away from under the deck during the removal.

## Replacing mowing deck belts

### Belt replacement on bioclip-deck

A bioclip-deck is driven by two synchronous transmission belts which synchronise the rotation of the blades. The belts are situated under a cover on the mowing deck. Replace the belts in the following way:

1

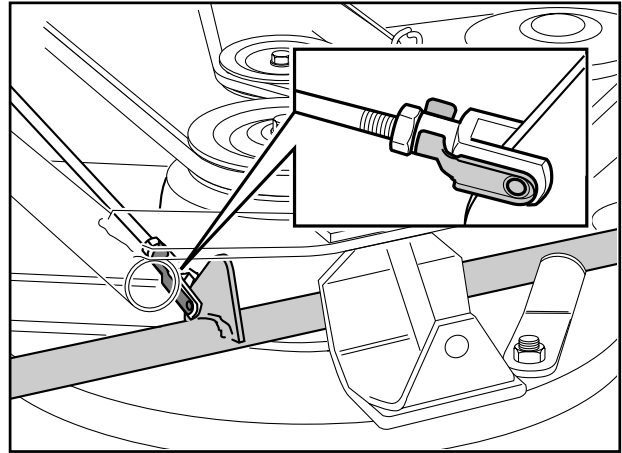

Release the parallel strut's front pin and bend the strut backwards.

2

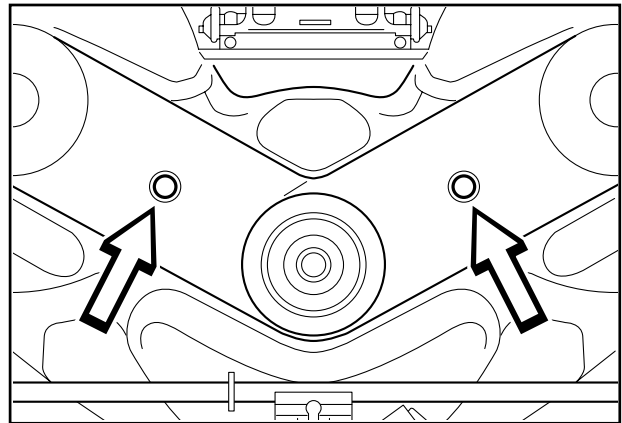

Unscrew the two screws which hold the safety guard and lift off the guard.

3

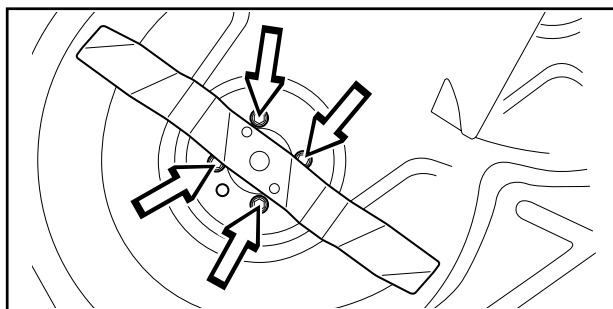

- Loosen the eccentric plate nut and twist it off.
- Loosen the four nuts (see diagram), which hold the outer blade bearing, so much so that the bearing can be moved.
- Press the blade bearing inwards towards the middle bearing and twist off the upper belt.
- Repeat the procedure with the lower belt.

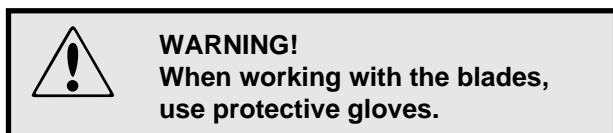

4

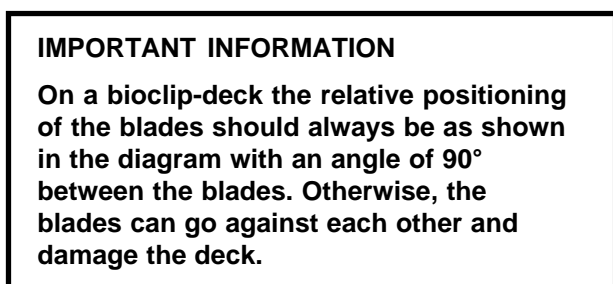
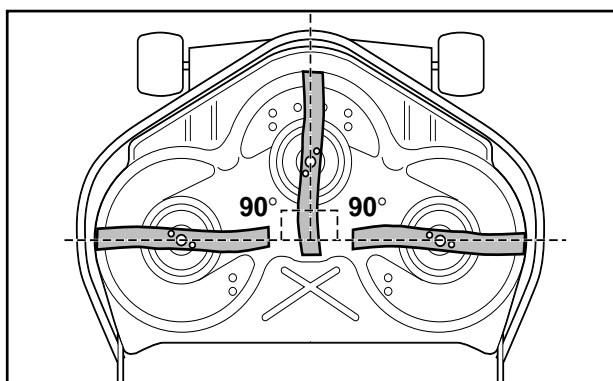

Fit the new belts in the following way:

- First, twist on the lower belt and then the upper one.
- Check that the blades are positioned in accordance with the diagram with 90° between them, otherwise the belts should be adjusted. When the blade bearing is loose, the belt can be slipped over to the next gear.
- Tighten the nuts so that the bearings lie close to the cutting cover, but so that they can be displaced.

5

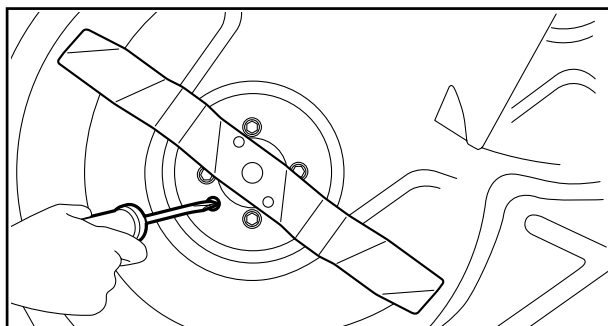

- Tension the belts by twisting in the eccentric tensioning device on the upper side of the mowing cover. Tighten the nut.
- Tighten all the nuts holding the blade bearings.

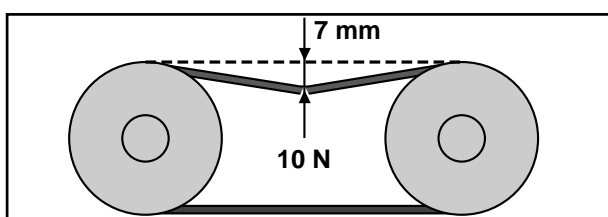

- When the belt moves 7 mm inwards at a force of 10N, the belt tension is correct.
- Fit the safety guard over the belts and attach the parallel strut.

### Belt replacement on mowing deck with side or rear discharge

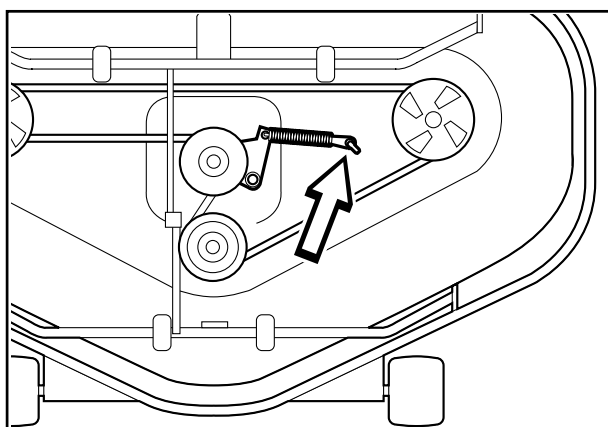

On mowing decks with side or rear discharge the blades are driven by a *single* V-belt. Replace the V-belt in the following way:

- Release the spring which tensions the V-belt and twist off the belt.
- Installing the new belt is carried out in the reverse order.



## Removal of blades with bearings

1

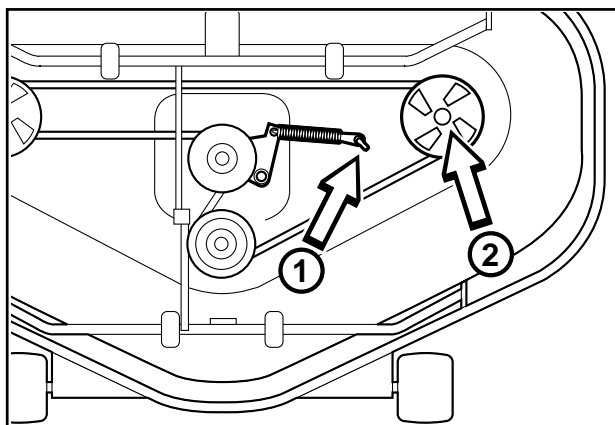

**WARNING!**  
When working with the mowing deck, use protective glasses and gloves.

- Release the spring which tensions the V-belt and twist off the belt.
- Unscrew the screw which holds the pulley (2) and detach the pulley, a puller may be needed for this. Do not lose the key which is found between the pulley and the axle.

2

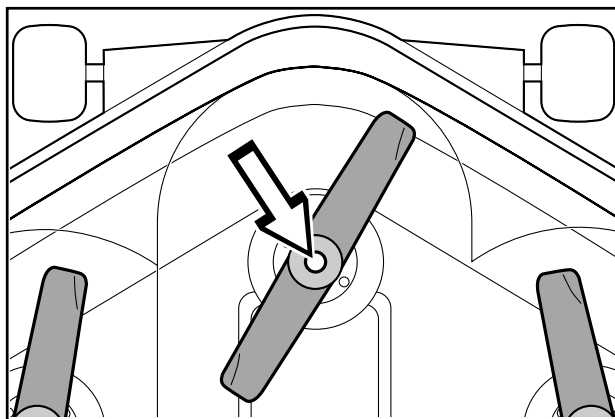

Unscrew the screw which holds the blade and remove the screw, washer and blade.

3

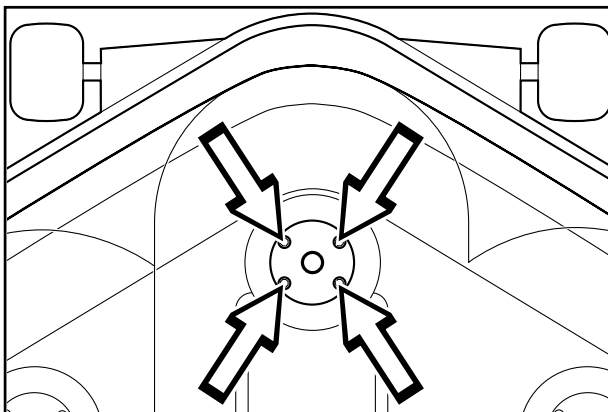

Unscrew the four screws which hold the blade bearing and remove the entire bearing packet from the mowing deck.

4

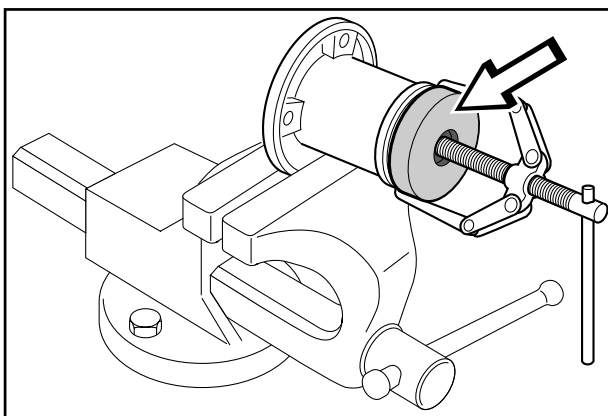

Remove the hub using a puller. Do not lose the key which is found between the pulley and the axle.

5

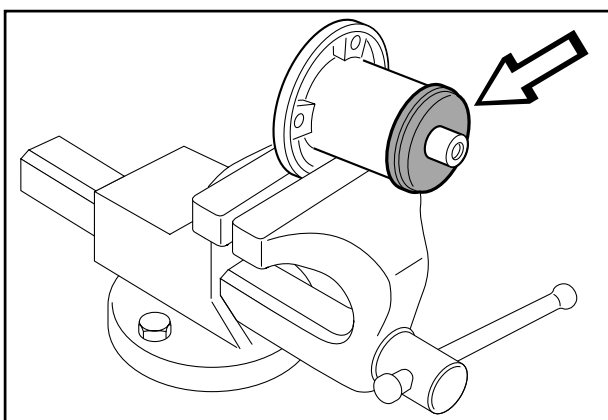

Remove the sheet metal safety washer.

6

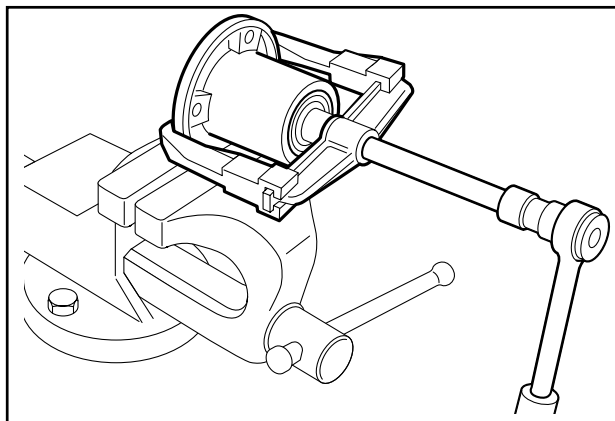

- Press out the axle with a puller.
- Knock out the bearings and remove the spacer.

7

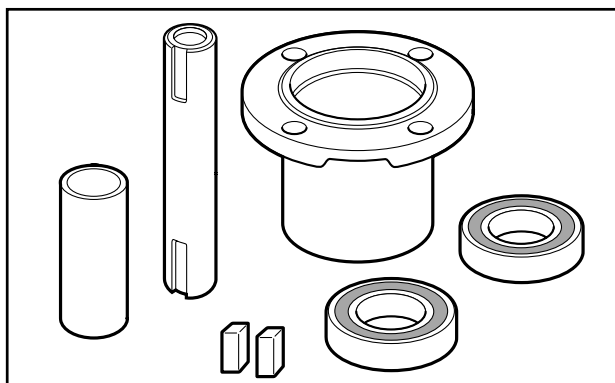

The entire packet can be bought as a complete set with axle housing, axle, spacer and bearing. The Rider 1200 set does not include an axle.

Model	Outer bearing	Middle bearing
Rider 850	506 53 34-01	506 53 34-02
Rider 970	506 75 11-01	506 75 11-04
Rider 970 Bioclip	506 75 11-05	506 75 11-04
Rider 1030 Bioclip	506 75 11-05	506 75 11-04
Rider 1200	506 75 11-01	506 75 11-03

Installation is carried out in the reverse removing order. Ensure that the axle is fixed in the same direction as it was removed, if not the keys will not fit into the key-way.

### IMPORTANT INFORMATION

**When screwing on the blade axle screws, the transmission side should always be screwed first and then the blade screws.**

## Grinding and balancing of blades

1

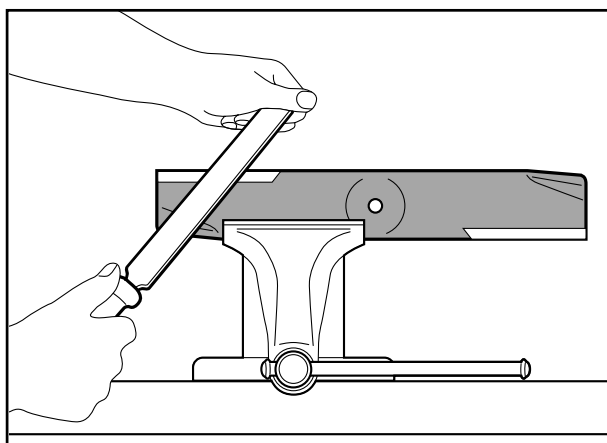

**WARNING!**  
When working with the blades, use protective gloves.

- Remove the blades according to the description in the previous section.
- Clamp the blade in a screw vice and file it so that it becomes sharp.

2

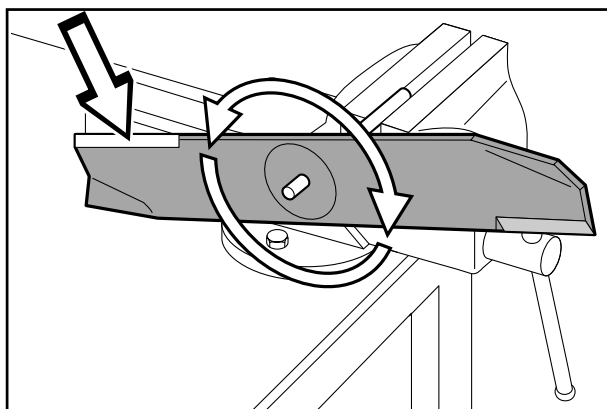

Balance the blade as follows:

- Fix, for example, a mandrel horizontally in a screw vice according to the diagram.
- Push the blade onto the mandrel via the hole in the centre of the blade and check that the blade balances evenly. The diagram shows a blade which needs to be adjusted, it must be ground further to obtain the correct balance (at the arrow).
- Installation is carried out in the reverse removing order.

## Electrical system

Circuit diagram Rider 850

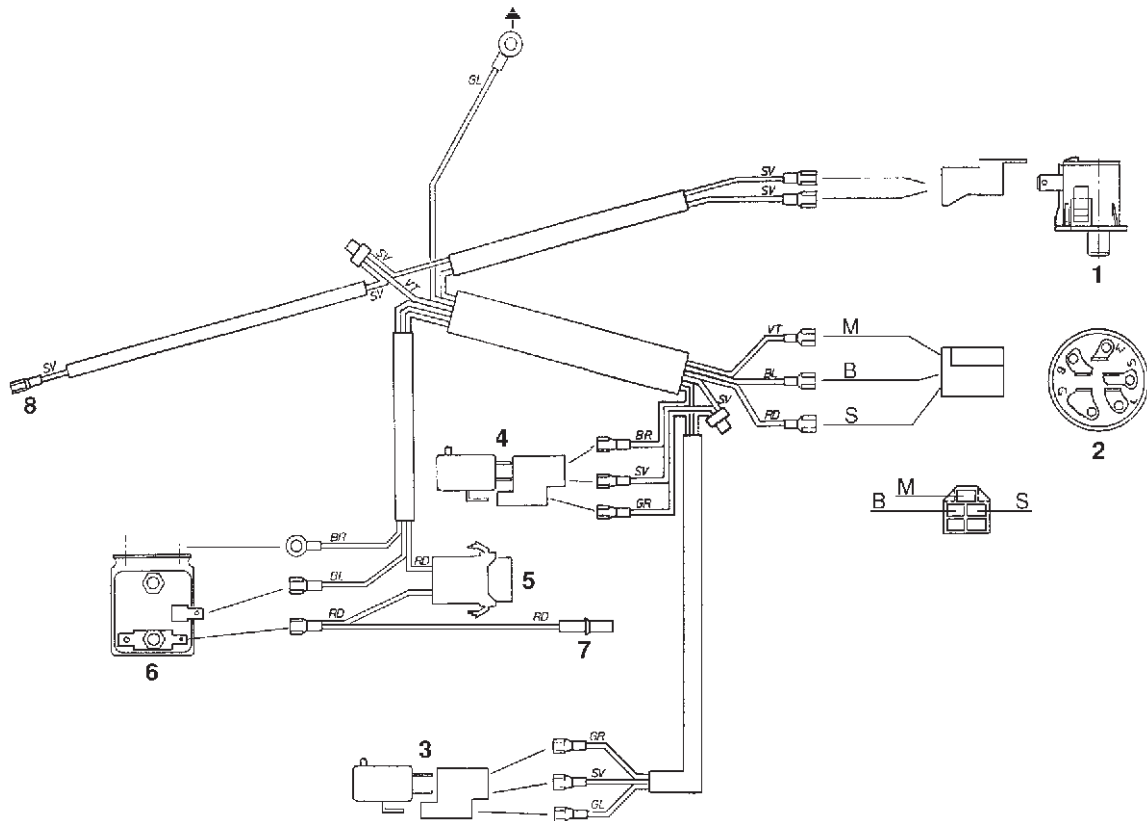
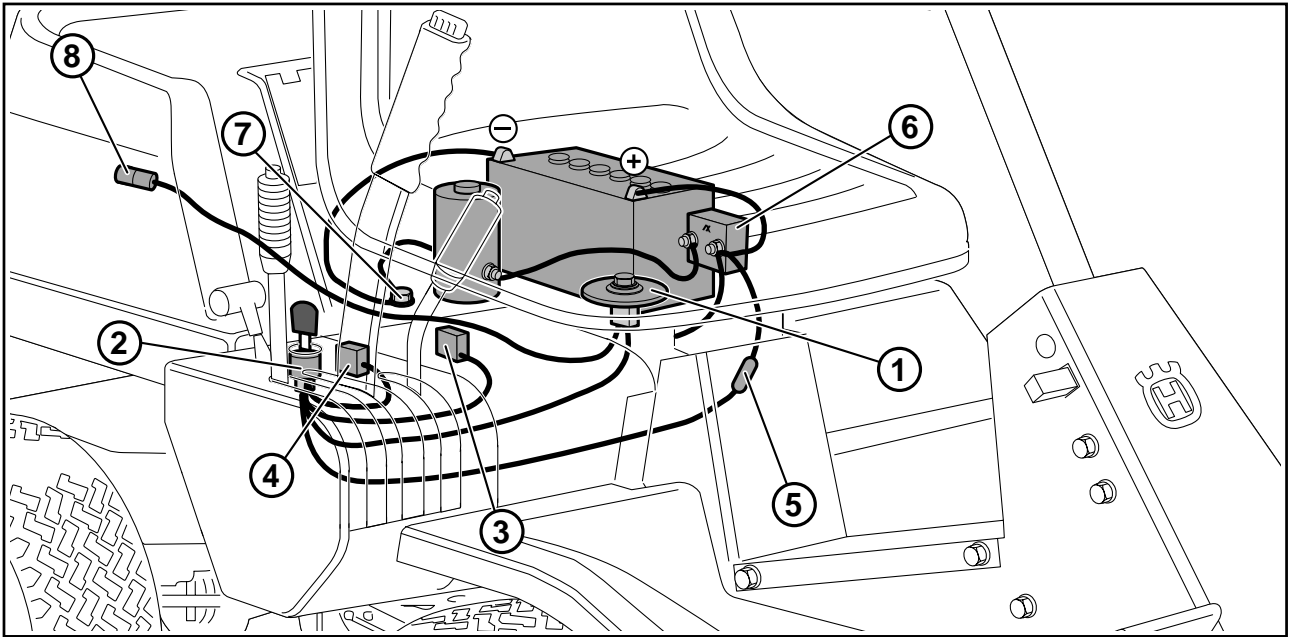

1. Microswitch, seat
2. Ignition lock
3. Microswitch, lifting lever
4. Microswitch, gear position
5. Fuse 15A
6. Starter relay
7. Engine/charging
8. Engine/stop

Key to colour abbreviations in the electrical system

- SV = Black
- RD = Red
- BR = Brown
- BL = Blue
- VT = White
- GL = Yellow
- GR = Green

## Circuit diagram Rider 970

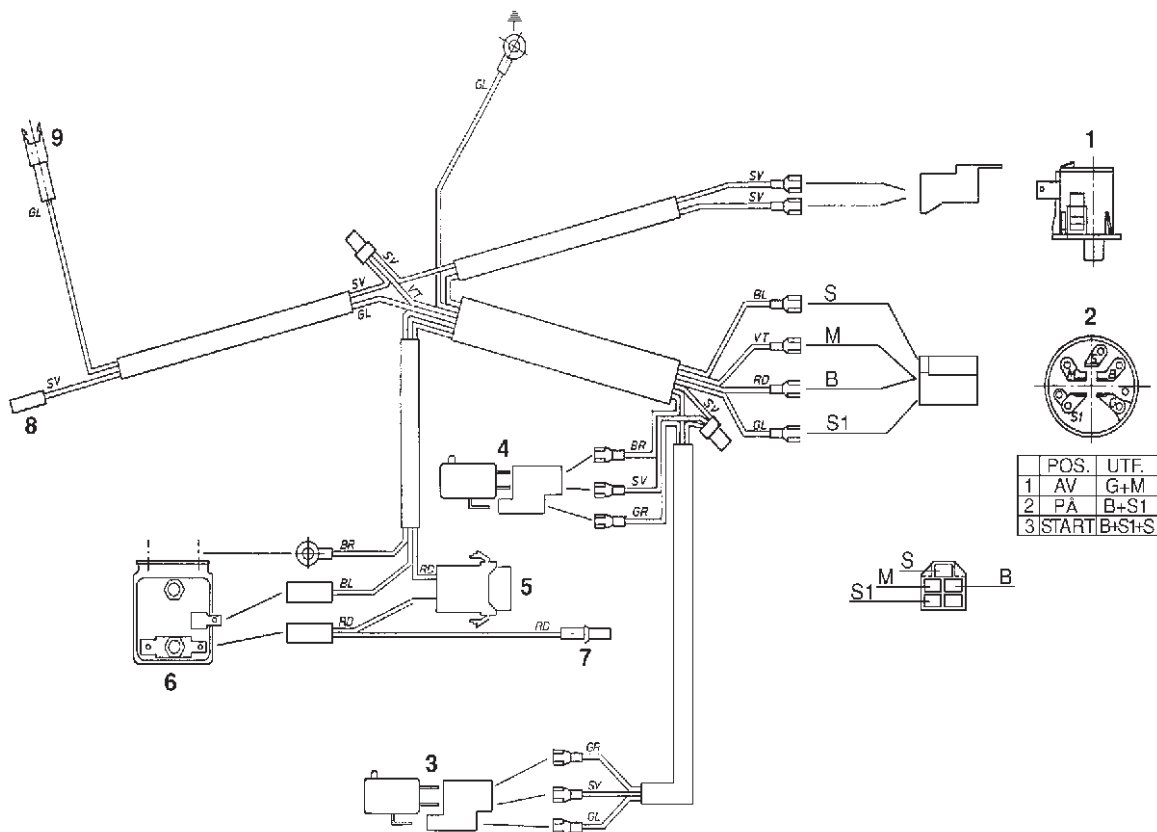
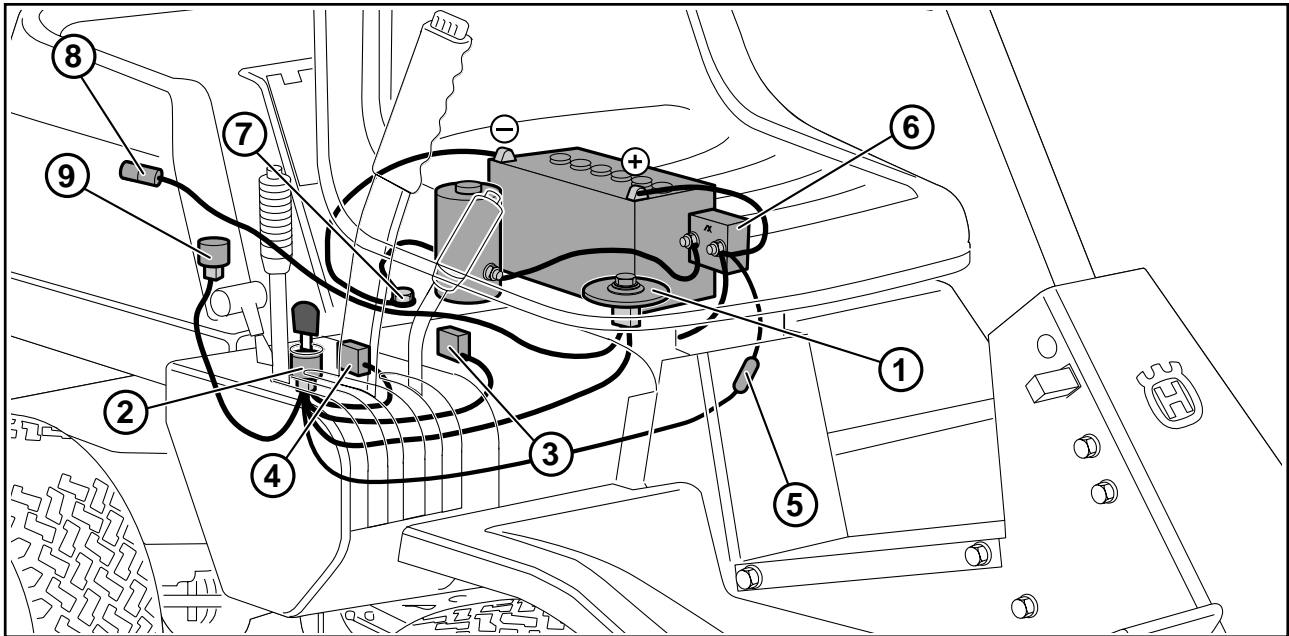

1. Microswitch, seat
2. Ignition lock
3. Microswitch, lifting lever
4. Microswitch, gear position
5. Fuse 15A
6. Starter relay
7. Engine/charging
8. Engine/stop
9. Engine/fuel valve

- Key to colour abbreviations in the electrical system
- SV = Black
  - RD = Red
  - BR = Brown
  - BL = Blue
  - VT = White
  - GL = Yellow
  - GR = Green

## Circuit diagram Rider 850/970 HST

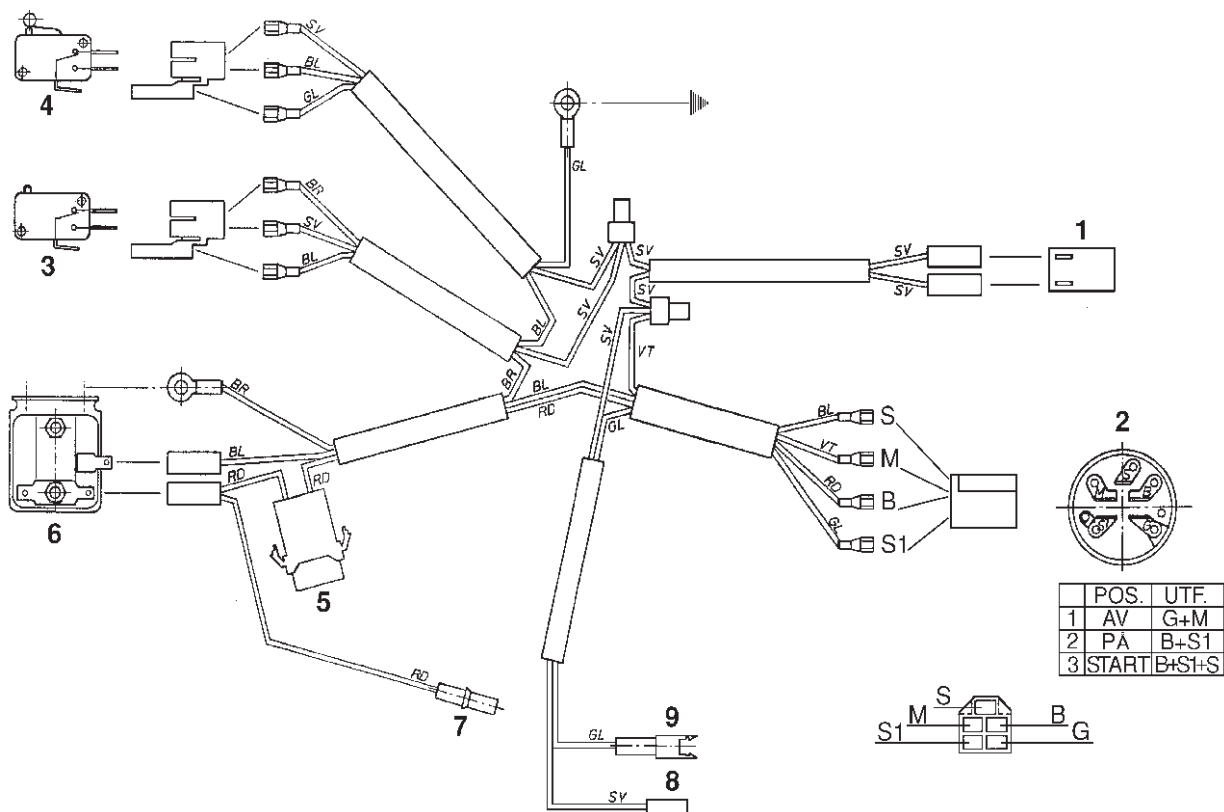
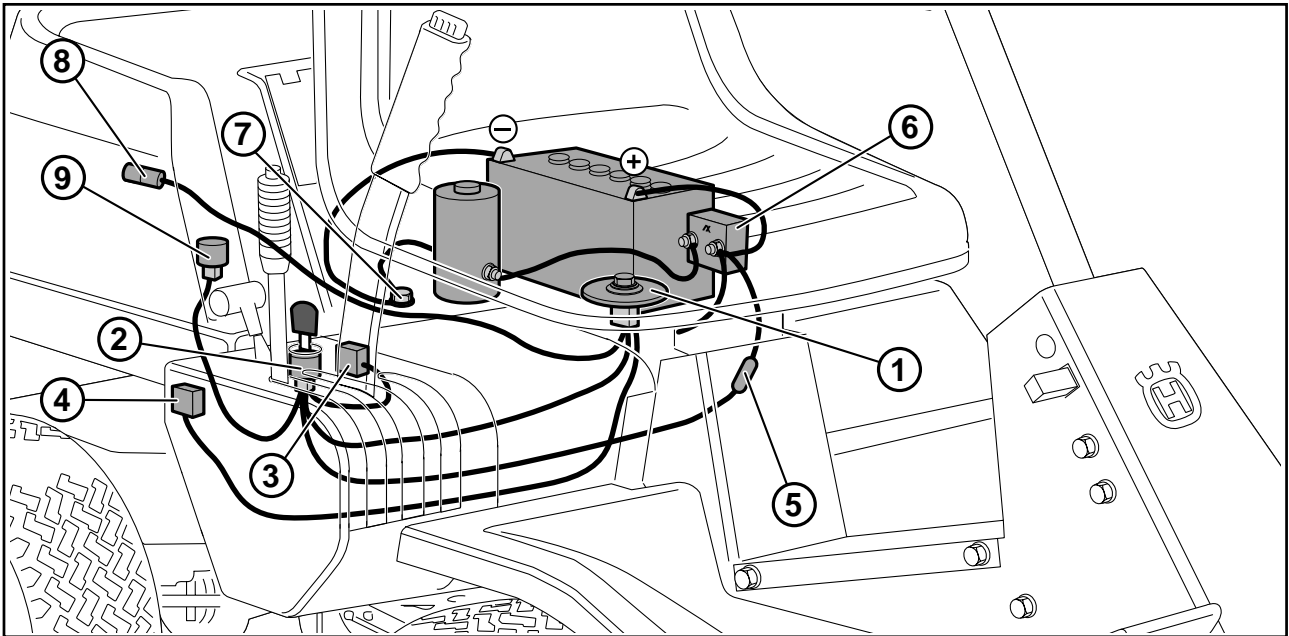

1. Microswitch, seat
2. Ignition lock
3. Microswitch, lifting lever
4. Microswitch, hydrostatic transmission
5. Fuse 15A
6. Starter relay
7. Engine/charging
8. Engine/stop
9. Engine/fuel valve

Key to colour abbreviations in the electrical system

- SV = Black
- RD = Red
- BR = Brown
- BL = Blue
- VT = White
- GL = Yellow

## Circuit diagram Rider 1030 Bioclip/1200

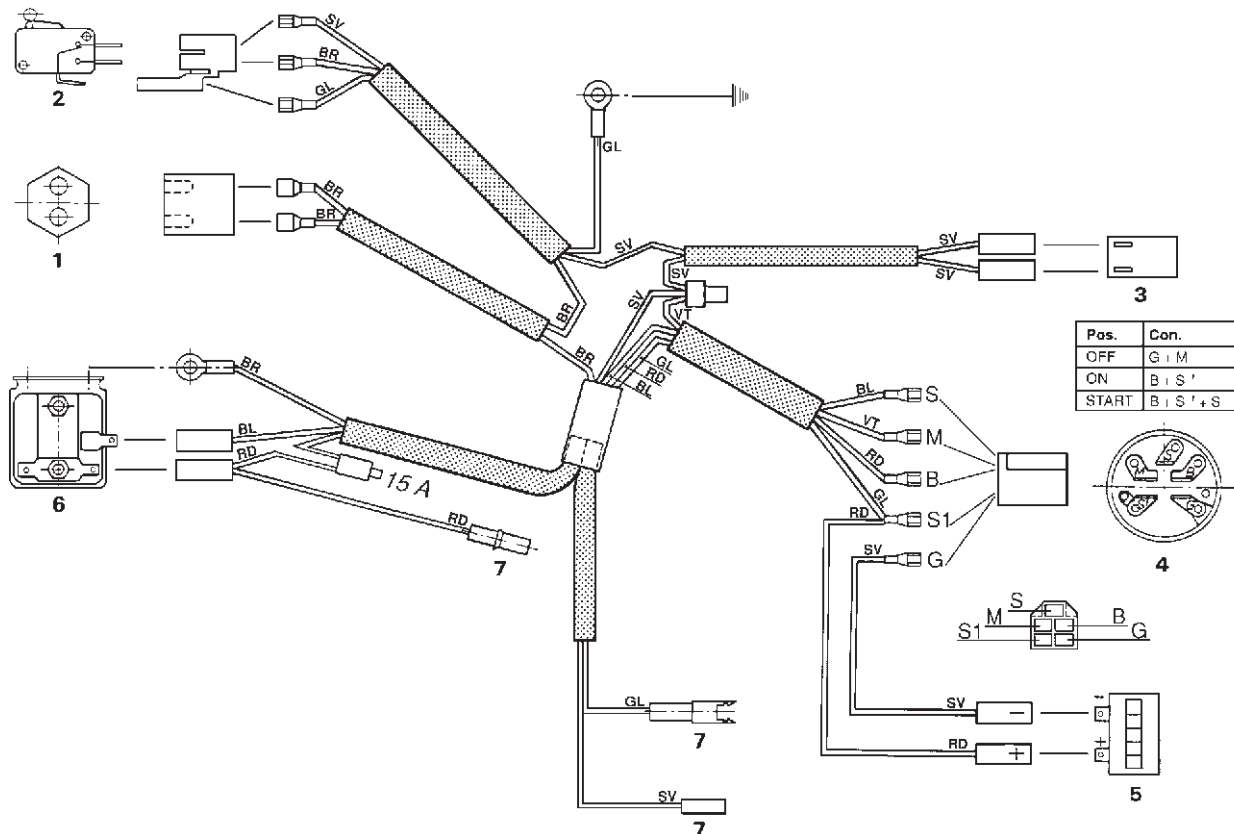
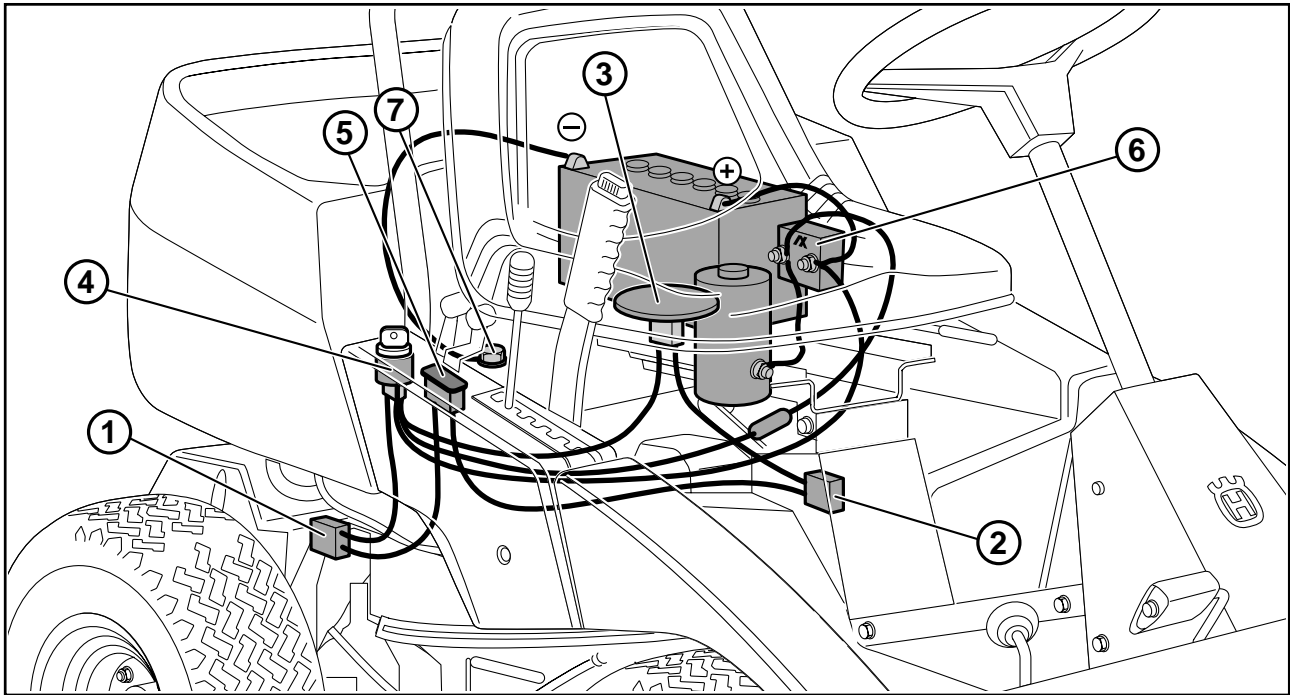

1. Brake switch, hydrostatic transmission
2. Microswitch, mowing deck
3. Microswitch, seat
4. Ignition lock
5. Timing unit
6. Starter relay
7. Engine

Key to colour abbreviations in the electrical system

- RD = Red
- BL = Blue
- VT = White
- SV = Black
- GL = Tellow
- BR = Brown



For Husqvarna Parts Call 606-678-9623 or 606-561-4983

Husqvarna  
Printed in U.S.A.

[www.mymowerparts.com](http://www.mymowerparts.com)