

F510 and F525 Residential Front Mowers

**John Deere Horicon Works
TM1475 (23OCT95)**

LITHO IN U.S.A.
ENGLISH

**F510 and F525 Residential
Front Mowers**

TM1475 (23OCT95)



Introduction

FOREWORD

This manual is written for an experienced technician. Essential tools required in performing certain service work are identified in this manual and are recommended for use.

Live with safety: Read the safety messages in the introduction of this manual and the cautions presented throughout the text of the manual.



This is the safety-alert symbol. When you see this symbol on the machine or in this manual, be alert to the potential for personal injury.

Technical manuals are divided in two parts: repair and operation and tests. Repair sections tell how to repair the components. Operation and tests sections help you identify the majority of routine failures quickly.

Information is organized in groups for the various components requiring service instruction. At the beginning of each group are summary listings of all applicable essential tools, service equipment and tools, other materials needed to do the job, service parts kits, specifications, wear tolerances, and torque values.

Technical Manuals are concise guides for specific machines. They are on-the-job guides containing only the vital information needed for diagnosis, analysis, testing, and repair.

Fundamental service information is available from other sources covering basic theory of operation, fundamentals of troubleshooting, general maintenance, and basic type of failures and their causes.

JOHN DEERE DEALERS

This is a complete revision for TM1475—F510 and F525 Residential Front Mowers.

Discard TM1475 dated (01MAY92) and replace with this manual.

New information added to this manual includes:

1. Updated engine repair procedures and specifications.
2. New engine adjustment procedures.
3. New electrical wiring harness diagrams.
4. New electrical schematics and diagnostic diagrams.
5. Updated electrical tests.
6. New mower deck repair procedures.
7. New lift linkage repair procedures.
8. New snowthrower repair information.
9. New snowthrower diagnostic information.
10. New snowthrower adjustment procedures.
11. New Power Flow™ repair information.
12. New Power Flow™ diagnostic information.

Contents

SECTION 10—GENERAL INFORMATION

- Group 05—Safety
- Group 10—General Specifications
- Group 15—Repair Specifications
- Group 20—Fuel and Lubricants
- Group 25—Serial Number Location

SECTION 20—ENGINE REPAIR

- Group 05—Remove and Install Engine
- Group 10—Blower Housing and Flywheel
- Group 15—Cylinder Head and Valves
- Group 20—Cylinder Block and Internal Components

SECTION 30—FUEL AND AIR SYSTEM REPAIR

- Group 05—Fuel Tank
- Group 10—Fuel Pump
- Group 15—Air Cleaner
- Group 20—Carburetor

SECTION 40—ELECTRICAL REPAIR

- Group 05—Electric PTO Clutch
- Group 10—Starter
- Group 15—Ignition and Charging System

SECTION 50—POWER TRAIN REPAIR

- Group 10—Hydrostatic Transmission and Differential

SECTION 60—STEERING REPAIR

- Group 05—Steering Shaft and Gears
- Group 10—Wheels

SECTION 65—BRAKE REPAIR

- Group 05—Brake Repair

SECTION 80—MISCELLANEOUS

- Group 05—Mower Deck Repair
- Group 10—Blade Drive Belt
- Group 15—38-Inch Snowthrower
- Group 20—Power Flow™ Blower Assembly
- Group 25—Engine Shroud and Fenders
- Group 30—Weight Transfer System

SECTION 210—SPECIFICATIONS/OPERATIONAL CHECKOUT PROCEDURE

- Group 05—Operational Checkout Procedure
- Group 10—Test and Adjustment Specifications

SECTION 220—ENGINE OPERATION, TESTS, AND

- Group 05—Engine Component Location
- Group 10—Theory of Operation
- Group 15—Diagnosis, Tests, and Adjustments

SECTION 230—FUEL/AIR OPERATION, TESTS, AND ADJUSTMENTS

- Group 05—Component Location
- Group 10—Theory of Operation
- Group 15—Diagnosis, Tests, and Adjustments

SECTION 240—ELECTRICAL SYSTEM OPERATION, TESTS, AND ADJUSTMENTS

- Group 05—Component Location
- Group 10—Theory of Operation
- Group 15—Diagnosis, Tests, and Adjustments
- Group 20—Wiring Schematic and Harness Diagram

SECTION 250—POWER TRAIN OPERATION, TESTS, AND ADJUSTMENTS

- Group 05—Power Train Component Location
- Group 10—Theory of Operation
- Group 15—Power Train Diagnosis

SECTION 260—STEERING OPERATION, TESTS, AND ADJUSTMENTS

- Group 05—Component Location
- Group 10—Theory of Operation
- Group 15—Diagnostics
- Group 20—Adjustments

SECTION 265—BRAKE OPERATION, TESTS, AND ADJUSTMENTS

- Group 05—Component Location
- Group 10—Theory of Operation

Continued on next page

All information, illustrations and specifications in this manual are based on the latest information available at the time of publication. The right is reserved to make changes at any time without notice.

TM1475-19-23OCT95

COPYRIGHT© 1995
DEERE & COMPANY
Moline, Illinois
All rights reserved
A John Deere ILLUSTRATION™ Manual
Previous Editions
Copyright 1992, 1989 Deere & Company

Group 15—Diagnostics
Group 20—Adjustments

10

**SECTION 280—MISCELLANEOUS OPERATION,
TESTS, AND ADJUSTMENTS**

Group 05—Component Location
Group 10—Theory of Operation
Group 15—Diagnosis and
Adjustments—Snowthrower
Group 20—Diagnosis—Power Flow™ Blower
Assembly

20

30

Index

40

50

60

65

80

210

220

230

240

250

260

265

280

INDX

230

240

250

260

265

280

INDX

Section 10 GENERAL INFORMATION

Contents

Page

Group 05—Safety 10-05-1

Group 10—General Specifications

Machine Specifications 10-10-1

Group 15—Repair Specifications

Engine Configuration Chart 10-15-1

Repair Specifications 10-15-2

Tune-Up Adjustments 10-15-13

Metric Cap Screw Torque Values 10-15-14

Inch Cap Screw Torque Values 10-15-15

Group 20 —Fuel and Lubricants

Group 25—Serial Number Location

Serial Number Information 10-25-1

Product Identification Number 10-25-1

Engine Serial Number 10-25-1

RECOGNIZE SAFETY INFORMATION

This is the safety-alert symbol. When you see this symbol on your machine or in this manual, be alert to the potential for personal injury.

Follow recommended precautions and safe operating practices.

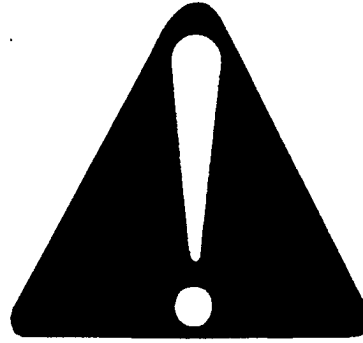

DX,ALERT -19-03MAR93

10
05
1
-UN-07DEC88
T81389

UNDERSTAND SIGNAL WORDS

A signal word—DANGER, WARNING, or CAUTION—is used with the safety-alert symbol. DANGER identifies the most serious hazards.

DANGER or WARNING safety signs are located near specific hazards. General precautions are listed on CAUTION safety signs. CAUTION also calls attention to safety messages in this manual.



DX,SIGNAL -19-03MAR93

-19-30SEP88
TS187

FOLLOW SAFETY INSTRUCTIONS

Carefully read all safety messages in this manual and on your machine safety signs. Keep safety signs in good condition. Replace missing or damaged safety signs. Be sure new equipment components and repair parts include the current safety signs. Replacement safety signs are available from your John Deere dealer.

Learn how to operate the machine and how to use controls properly. Do not let anyone operate without instruction.

Keep your machine in proper working condition. Unauthorized modifications to the machine may impair the function and/or safety and affect machine life.

If you do not understand any part of this manual and need assistance, contact your John Deere dealer.



DX,READ -19-03MAR93

-UN-23AUG88
TS201

HANDLE FLUIDS SAFELY—AVOID FIRES

When you work around fuel, do not smoke or work near heaters or other fire hazards.

Store flammable fluids away from fire hazards. Do not incinerate or puncture pressurized containers.

Make sure machine is clean of trash, grease, and debris.

Do not store oily rags; they can ignite and burn spontaneously.



DX,FLAME -19-04JUN90

-UN-23AUG88
TS227

PREVENT BATTERY EXPLOSIONS

Keep sparks, lighted matches, and open flame away from the top of battery. Battery gas can explode.

Never check battery charge by placing a metal object across the posts. Use a volt-meter or hydrometer.

Do not charge a frozen battery; it may explode. Warm battery to 16°C (60°F).



DX,SPARKS -19-03MAR93

-UN-23AUG88
TS204

PREPARE FOR EMERGENCIES

Be prepared if a fire starts.

Keep a first aid kit and fire extinguisher handy.

Keep emergency numbers for doctors, ambulance service, hospital, and fire department near your telephone.

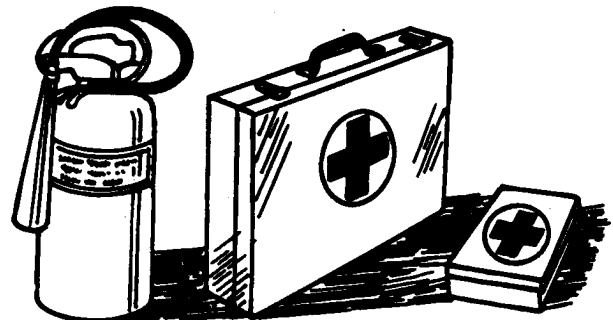

DX,FIRE2 -19-03MAR93

-UN-23AUG88
TS291

PREVENT ACID BURNS

Sulfuric acid in battery electrolyte is poisonous. It is strong enough to burn skin, eat holes in clothing, and cause blindness if splashed into eyes.

Avoid the hazard by:

1. Filling batteries in a well-ventilated area.
2. Wearing eye protection and rubber gloves.
3. Avoiding breathing fumes when electrolyte is added.
4. Avoiding spilling or dripping electrolyte.
5. Use proper jump start procedure.

If you spill acid on yourself:

1. Flush your skin with water.
2. Apply baking soda or lime to help neutralize the acid.
3. Flush your eyes with water for 15—30 minutes. Get medical attention immediately.

If acid is swallowed:

1. Do not induce vomiting.
2. Drink large amounts of water or milk, but do not exceed 2 L (2 quarts).
3. Get medical attention immediately.

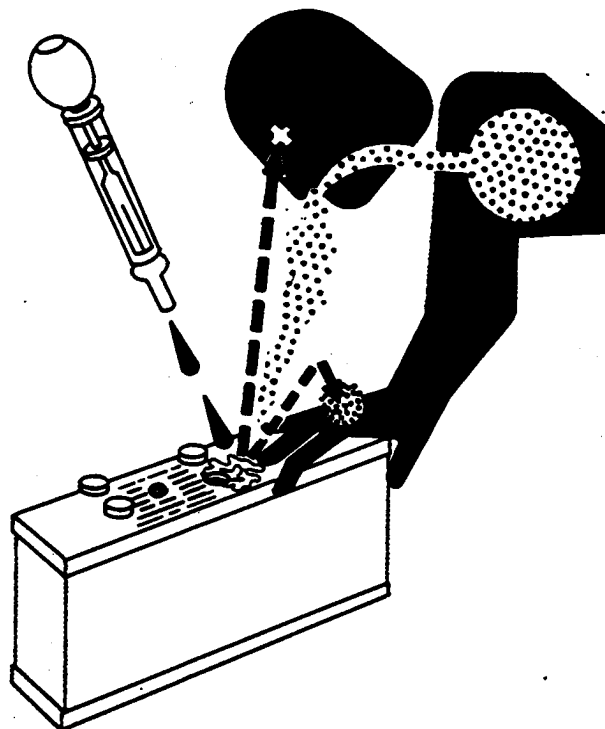

DX,POISON -19-21APR93

TSS203 -UN-23AUG88

HANDLE CHEMICAL PRODUCTS SAFELY

Direct exposure to chemical products can cause severe skin irritation and injury. Hazardous fumes can be generated when handling the chemicals.

Wear close fitting clothing and a face mask when handling chemicals. Dispose of chemical waste and packaging material properly.

A Material Safety Data Sheet provides specific details on chemical products and physical dangers, safety procedures, and emergency response techniques. User awareness and training is required under U.S. workplace and environmental laws. See your John Deere dealer for information on chemical products used with John Deere equipment.



DX,MSDS -19-28SEP90

TSS272 -UN-23AUG88

10
05
4

AVOID HIGH-PRESSURE FLUIDS

Escaping fluid under pressure can penetrate the skin causing serious injury.

Avoid the hazard by relieving pressure before disconnecting hydraulic or other lines. Tighten all connections before applying pressure.

Search for leaks with a piece of cardboard. Protect hands and body from high pressure fluids.

If an accident occurs, see a doctor immediately. Any fluid injected into the skin must be surgically removed within a few hours or gangrene may result. Doctors unfamiliar with this type of injury should reference a knowledgeable medical source. Such information is available from Deere & Company Medical Department in Moline, Illinois, U.S.A.

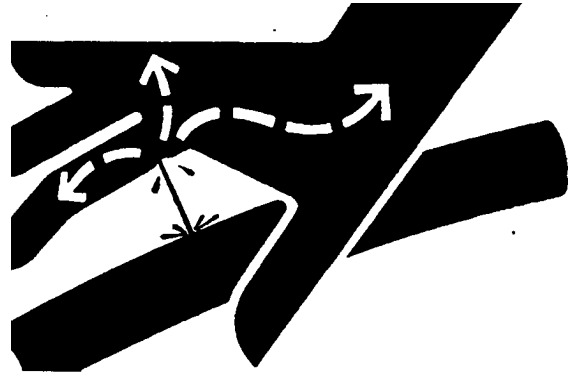

-UN-23AUG88

X9811

DX,FLUID -19-03MAR93

PARK MACHINE SAFELY

Before working on the machine:

- Lower all equipment to the ground.
- Stop the engine and remove the key.
- Disconnect the battery ground strap.
- Hang a "DO NOT OPERATE" tag in operator station.

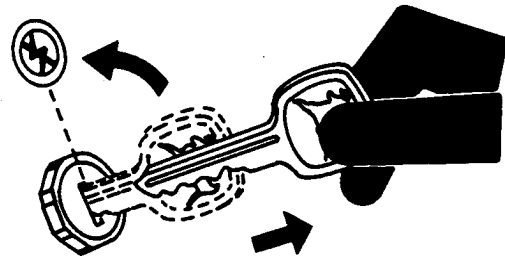

-UN-24MAY89

TS230

DX,PARK -19-04JUN90

SUPPORT MACHINE PROPERLY

Always lower the attachment or implement to the ground before you work on the machine. If you must work on a lifted machine or attachment, securely support the machine or attachment.

Do not support the machine on cinder blocks, hollow tiles, or props that may crumble under continuous load. Do not work under a machine that is supported solely by a jack. Follow recommended procedures in this manual.

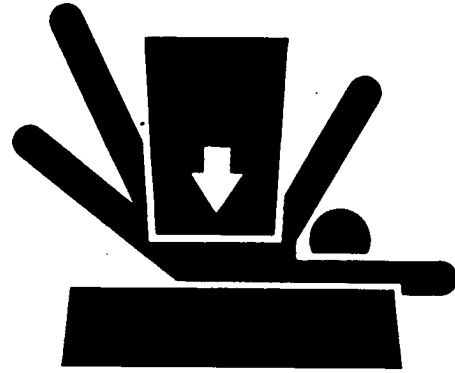

DX,LOWER -19-04JUN90

51910
-UN-23AUG88
TS229

WEAR PROTECTIVE CLOTHING

Wear close fitting clothing and safety equipment appropriate to the job.

Prolonged exposure to loud noise can cause impairment or loss of hearing.

Wear a suitable hearing protective device such as earmuffs or earplugs to protect against objectionable or uncomfortable loud noises.

Operating equipment safely requires the full attention of the operator. Do not wear radio or music headphones while operating machine.

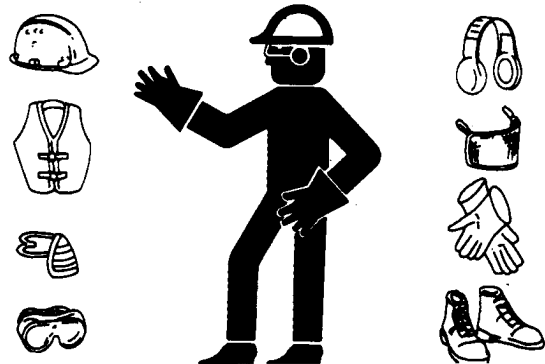

DX,WEAR -19-10SEP90

-UN-23AUG88
TS206

SERVICE MACHINES SAFELY

Tie long hair behind your head. Do not wear a necktie, scarf, loose clothing, or necklace when you work near machine tools or moving parts. If these items were to get caught, severe injury could result.

Remove rings and other jewelry to prevent electrical shorts and entanglement in moving parts.

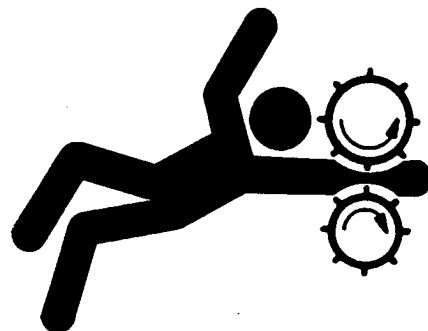

DX,LOOSE -19-04JUN90

-UN-23AUG88
TS228

WORK IN VENTILATED AREA

Engine exhaust fumes can cause sickness or death. If it is necessary to run an engine in an enclosed area, remove the exhaust fumes from the area with an exhaust pipe extension.

If you do not have an exhaust pipe extension, open the doors and get outside air into the area.

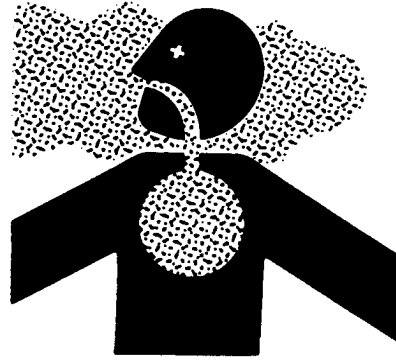

DX,AIR -19-04JUN90

TS220 -UN-23AUG88

WORK IN CLEAN AREA

Before starting a job:

- Clean work area and machine.
- Make sure you have all necessary tools to do your job.
- Have the right parts on hand.
- Read all instructions thoroughly; do not attempt shortcuts.

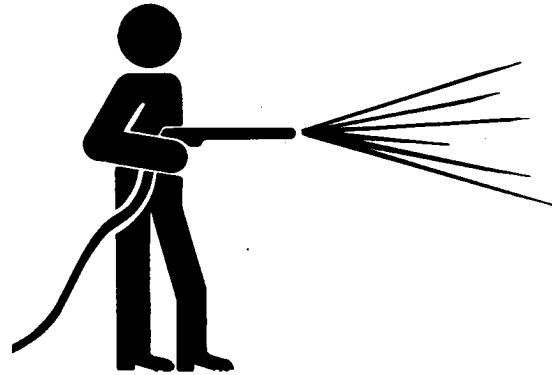

DX,CLEAN -19-04JUN90

T6642EJ -UN-18OCT88

REMOVE PAINT BEFORE WELDING OR HEATING

Avoid potentially toxic fumes and dust.

Hazardous fumes can be generated when paint is heated by welding, soldering, or using a torch.

Do all work outside or in a well ventilated area. Dispose of paint and solvent properly.

Remove paint before welding or heating:

- If you sand or grind paint, avoid breathing the dust. Wear an approved respirator.
- If you use solvent or paint stripper, remove stripper with soap and water before welding. Remove solvent or paint stripper containers and other flammable material from area. Allow fumes to disperse at least 15 minutes before welding or heating.

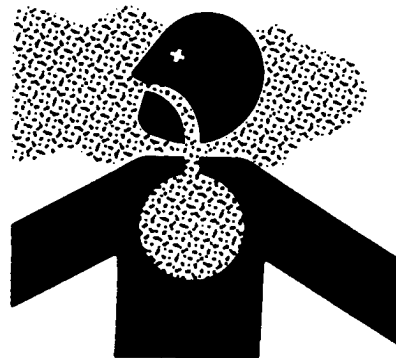

DX,PAINT -19-03MAR93

TS220 -UN-23AUG88

AVOID HEATING NEAR PRESSURIZED FLUID LINES

Flammable spray can be generated by heating near pressurized fluid lines, resulting in severe burns to yourself and bystanders. Do not heat by welding, soldering, or using a torch near pressurized fluid lines or other flammable materials. Pressurized lines can be accidentally cut when heat goes beyond the immediate flame area.



DX,TORCH -19-03MAR93

7510
-UN-15MAY90
TS953

ILLUMINATE WORK AREA SAFELY

Illuminate your work area adequately but safely. Use a portable safety light for working inside or under the machine. Make sure the bulb is enclosed by a wire cage. The hot filament of an accidentally broken bulb can ignite spilled fuel or oil.

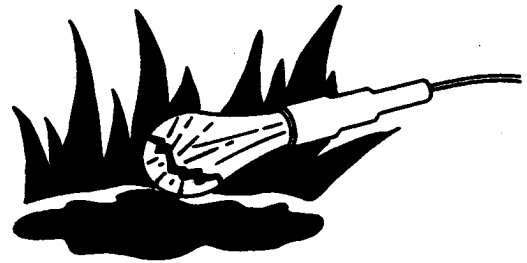

DX,LIGHT -19-04JUN90

-UN-23AUG88
TS223

REPLACE SAFETY SIGNS

Replace missing or damaged safety signs. See the machine operator's manual for correct safety sign placement.



DX,SIGNS1 -19-04JUN90

-UN-23AUG88
TS201

USE PROPER LIFTING EQUIPMENT

Lifting heavy components incorrectly can cause severe injury or machine damage.

Follow recommended procedure for removal and installation of components in the manual.

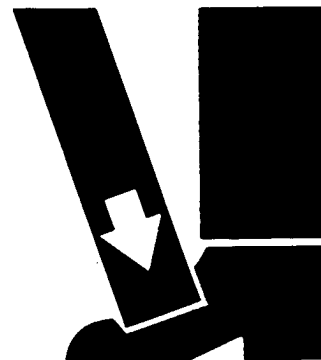

DX,LIFT -19-04JUN90

-UN-23AUG88
TS226

10
05
8

SERVICE TIRES SAFELY

Explosive separation of a tire and rim parts can cause serious injury or death.

Do not attempt to mount a tire unless you have the proper equipment and experience to perform the job.

Always maintain the correct tire pressure. Do not inflate the tires above the recommended pressure. Never weld or heat a wheel and tire assembly. The heat can cause an increase in air pressure resulting in a tire explosion. Welding can structurally weaken or deform the wheel.

When inflating tires, use a clip-on chuck and extension hose long enough to allow you to stand to one side and NOT in front of or over the tire assembly. Use a safety cage if available.

Check wheels for low pressure, cuts, bubbles, damaged rims or missing lug bolts and nuts.

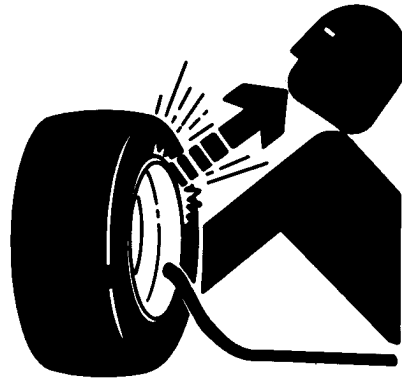

TS952 -UN-12APR90

DX,TIRECP -19-24AUG90

AVOID HARMFUL ASBESTOS DUST

Avoid breathing dust that may be generated when handling components containing asbestos fibers. Inhaled asbestos fibers may cause lung cancer.

Components in products that may contain asbestos fibers are brake pads, brake band and lining assemblies, clutch plates, and some gaskets. The asbestos used in these components is usually found in a resin or sealed in some way. Normal handling is not hazardous as long as airborne dust containing asbestos is not generated.

Avoid creating dust. Never use compressed air for cleaning. Avoid brushing or grinding material containing asbestos. When servicing, wear an approved respirator. A special vacuum cleaner is recommended to clean asbestos. If not available, apply a mist of oil or water on the material containing asbestos.

Keep bystanders away from the area.

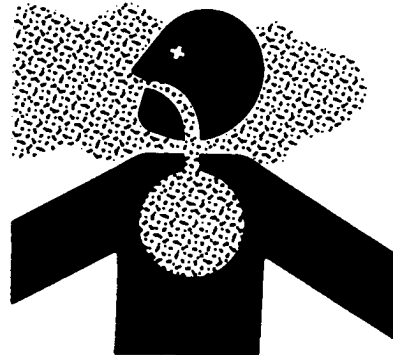

TS220 -UN-23AUG88

DX,DUST -19-15MAR91

PRACTICE SAFE MAINTENANCE

Understand service procedure before doing work. Keep area clean and dry.

Never lubricate, service, or adjust machine while it is moving. Keep hands, feet, and clothing from power-driven parts. Disengage all power and operate controls to relieve pressure. Lower equipment to the ground. Stop the engine. Remove the key. Allow machine to cool.

Securely support any machine elements that must be raised for service work.

Keep all parts in good condition and properly installed. Fix damage immediately. Replace worn or broken parts. Remove any buildup of grease, oil, or debris.

Disconnect battery ground cable (-) before making adjustments on electrical systems or welding on machine.



DX,SERV -19-03MAR93

TS218 -UN-23AUG88

USE PROPER TOOLS

Use tools appropriate to the work. Makeshift tools and procedures can create safety hazards.

Use power tools only to loosen threaded parts and fasteners.

For loosening and tightening hardware, use the correct size tools. DO NOT use U.S. measurement tools on metric fasteners. Avoid bodily injury caused by slipping wrenches.

Use only service parts meeting John Deere specifications.



DX,REPAIR -19-04JUN90

TS779 -UN-08NOV89

10
05
10

DISPOSE OF WASTE PROPERLY

Improperly disposing of waste can threaten the environment and ecology. Potentially harmful waste used with John Deere equipment include such items as oil, fuel, coolant, brake fluid, filters, and batteries.

Use leakproof containers when draining fluids. Do not use food or beverage containers that may mislead someone into drinking from them.

Do not pour waste onto the ground, down a drain, or into any water source.

Air conditioning refrigerants escaping into the air can damage the Earth's atmosphere. Government regulations may require a certified air conditioning service center to recover and recycle used air conditioning refrigerants.

Inquire on the proper way to recycle or dispose of waste from your local environmental or recycling center, or from your John Deere dealer.

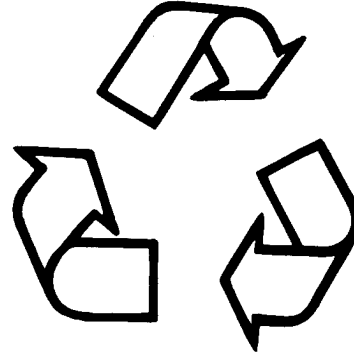

TS1133 -JUN-26NOV90

DX,DRAIN -19-03MAR93

LIVE WITH SAFETY

Before returning machine to customer, make sure machine is functioning properly, especially the safety systems. Install all guards and shields.



TS231 -19-07OCT88

DX,LIVE -19-25SEP92

MACHINE SPECIFICATIONS

	F510	F525
ENGINE	PA420A	PA540A
Manufacturer	KHI	KHI
Cycle	4	4
Output	10.4 kW (14 hp)	12.7 kW (17 hp)
Displacement	423 cc (25.8 cu. in.)	535 cc (32.64 cu. in.)
Cylinders	1	1
Crankshaft Alignment	Vertical	Vertical
Bore	89 mm (3.5 in.)	89 mm (3.5 in.)
Stroke	68 mm (2.68 in.)	86 mm (3.38 in.)
Speed, fast (no load)	3250 ±50 rpm	3250 ±50 rpm
Speed, idle (no load)	1450 rpm	1450 rpm
Ignition	Solid state	Solid state
Starter	Electric	Electric
Cooling	Air	Air
Unitized Eng/Trans		
Oil Reservoir Capacity:		
Without filter	2.4 L (2.5 qt)	2.6 L (2.7 qt)
With filter	2.6 L (2.7 qt)	2.8 L (2.9 qt)
Total system	3.4 L (3.5 qt)	3.9 L (4.1 qt)
Air Cleaner	Dry Replaceable w/foam precleaner	Dry Replaceable w/foam precleaner
POWER TAKE-OFF	Electric	Electric
CONSTRUCTION		
Block	Aluminum	Aluminum
Cylinder Liner	Cast iron	Cast iron
Cylinder Head	Aluminum	Aluminum
ELECTRICAL SYSTEM		
Charging System	Flywheel Alternator; 13 AMP, Regulated	Flywheel Alternator; 15 AMP, Regulated
Battery Voltage	12	12
Reserve Capacity @ 25 Amp	35 minutes	35 minutes
Cold Cranking Amp @ -18°C (0°F)	255	255
Spark Plug	RN11YC or NGK-BPR5ES	RN11YC or NGK-BPR5ES
Plug Gap	0.7-0.8 mm (0.28-0.031 in.)	0.7-0.8 mm (0.28-0.31 in.)
FUEL SYSTEM		
Fuel Tank Location	Left side	Left side
Capacity	10.4 L (2.75 U.S. gal)	10.4 L (2.75 U.S. gal)
Fuel Type	Unleaded Gasoline	Unleaded Gasoline
DRIVE TRAIN		
Transmission Type	Hydrostatic	Hydrostatic
Manufacturer	KHI	KHI
No. of Speeds	Infinite	Infinite
Travel Speeds		
Forward (Max)	8 km/h (5 MPH)	8 km/h (5 MPH)
Reverse (Max)	4 km/h (2.5 MPH)	4 km/h (2.5 MPH)

MX,1010CL,A1 -19-23OCT95

MACHINE SPECIFICATIONS (CONTINUED)

	F510	F525
DRIVE TRAIN-CONTINUED		
Differential	Bevel gear	Bevel gear
Gear Ratio	25:1	25:1
Speed & Direction Control	2 Pedal foot control	2 Pedal foot control
DIMENSIONS		
Height to Top of Steering Wheel	1067 mm (42 in.)	1067 mm (42 in.)
Height to Top of Hood	572 mm (22.5 in.)	572 mm (22.5 in.)
Width		
With 38 in. Mower	1300 mm (50 in.)	
With 46 in. Mower		1448 mm (57 in.)
With 48 in. Mower		1500 mm (59 in.)
Length		
Without Mower	1648 mm (65 in.)	1648 mm (64 in.)
With 38 in. Mower	2100 mm (82 in.)	
With 46 in. Mower		2010 mm (79 in.)
With 48 in. Mower		2000 mm (80 in.)
Ground Clearance	89 mm (3.5 in.)	89 mm (3.5 in.)
Wheelbase	885 mm (35 in.)	885 mm (35 in.)
Min. Turn Radius		
Left Hand	191 mm (7.5 in.)	191 mm (7.5 in.)
TIRES		
Type		
Drive	Soft Track Turf	Soft Track Turf
Steering	Rib	Rib
Size		
Drive	18x8.50-8	18x8.50-8
Steering	13x6.50-6	13x6.50-6
Inflation Pressure		
Drive	96 kPa (14 psi)	96 kPa (14 psi)
Steering	96 kPa (14 psi)	96 kPa (14 psi)
STEERING		
Type	Manual - Rear Wheel	Manual - Rear Wheel
BRAKES		
Type	Internal Wet Band	Internal Wet Band
Location	Internal to Drive	Internal to Drive
FRAME		
	Welded steel	Welded steel
MOWER DECK		
Cutting Width	965 mm (38 in.)	1212 mm (48 in.) or 1168 (46 in.)
Cutting Height	25-89 mm (1-3.5 in.)	25-89 mm (1-3.5 in.)
WEIGHT (APPROX)		
	314 kg (692 lbs)	316 kg (696 lbs) with 46 in. deck 336 kg (740 lbs) with 48 in. deck

(Specifications and design subject to change without notice.)

MX,1010CL,A2 -19-23OCT95

ENGINE CONFIGURATION CHART

The PA420A and PA540A engines have an engine configuration number following the engine model number to help separate engine changes. Use the engine configuration number to determine the proper service specifications and procedures to follow in this technical manual.

ENGINE CONFIGURATION CHART

F510 (Engine S.N. -3887)	PA420A-AS00
(Engine S.N. 3888-4898)	PA420A-BS00
(Engine S.N. 4899-7322)	PA420A-AS01
(Engine S.N. 7323-)	PA420A-AS02
F525 (Engine S.N. -7891)	PA540A-AS00
(Engine S.N. 7892-11999)	PA540A-BS00
(Engine S.N. 12000-21944)	PA540A-AS01
(Engine S.N. 21945-)	PA540A-AS02

MX,1015CL,1 -19-23OCT95

REPAIR SPECIFICATIONS

SECTION 20—ENGINE REPAIR—PA420A

Group 10—Blower Housing and Flywheel

Item	Specification
Flywheel Nut Torque	137 N·m (101 lb-ft)
Minimum Flywheel Screen Gap	1.50 mm (0.059 in.)

Group 15—Cylinder Head and Valves

Item	Specification
Valve Clearance	0.15 mm (0.006 in.)
Breather Air Gap	1—2 mm (0.040—0.080 in.)
Rocker Arm	
Minimum Shaft O.D.	12.94 mm (0.509 in.)
Maximum Bearing I.D.	13.07 mm (0.515 in.)
Push Rod	
Maximum Bend	0.30 mm (0.012 in.)
Valves and Springs	
Minimum Spring Free Length	
PA420A-AS00	37.50 mm (1.476 in.)
PA420A-BS00, AS01 and AS02	35.50 mm (1.398 in.)
Minimum Valve Stem O.D.	
Intake Valve	6.930 mm (0.2728 in.)
Exhaust Valve	6.915 mm (0.2722 in.)
Valve Stem O.D.-New Parts	
Intake Valve	6.972-6.987 mm (0.2745-0.2751 in.)
Exhaust Valve	6.965-6.980 mm (0.2742-0.2748 in.)
Valve Stem to Guide Clearance-New Parts	
Intake Valve	0.013-0.043 mm (0.0005-0.0017 in.)
Exhaust Valve	0.020-0.050 mm (0.0008-0.0020 in.)
Maximum Valve Guide I.D.	7.07 mm (0.278 in.)
Valve Guide I.D.-New Parts	7.000-7.015 mm (0.2756-0.2762 in.)
Valve Stem to Guide Clearance-New Parts	
Intake Valve	0.013-0.043 mm (0.0005-0.0017 in.)
Exhaust Valve	0.020-0.050 mm (0.0008-0.0020 in.)
Valve Guide Bushing Height	
PA420A-BS00, AS01 and AS02	12 mm (0.472 in.)
Valve Guide Bushing Finished I.D.	7.0-7.02 mm (0.275-0.276 in.)
Maximum Valve Stem Bend	0.03 mm (0.001 in.)

Continued on next page

MX,1015CL,1A -19-23OCT95

Group 15—Cylinder Head and Valves—Continued

Item	Specification
Valve Seating Surface	1.10—1.46 mm (0.043—0.057 in.)
Valve Seat and Face Angle	45°
Minimum Valve Margin	0.60 mm (0.020 in.)
Valve Narrowing Angle	30°
Cylinder Head	
Cylinder Head Distortion (Maximum)	0.05 mm
Studs Torque	36 N·m (27 lb-ft)
Cap Screw Torque In Sequence (Lubricated)	
Initial Torque	32 N·m (24 lb-ft)
Final Torque	52 N·m (38 lb-ft)
Spark Plug Torque	20 N·m (177 lb-in.)

Group 20—Cylinder Block and Internal Components

Item	Specification
Crankcase Cover	
Oil Capacity	
Without Filter	2.4 L (2.5 qt)
With Filter	2.6 L (2.7 qt)
Total System	3.4 L (3.5 qt)
Cap Screw Torque PA420A-BS00, AS00 and AS01	23 N·m (204 lb-in.)
Cap Screw Torque PA420A-AS02	29 N·m (257 lb-in.)
Hydrostatic Pump Cover Torque	25 N·m (226 lb-in.)
Oil Drain Plug	24 N·m (217 lb-in.)
Magnet Cap Screw Torque	6 N·m (53 lb-in.)
Camshaft	
Minimum End Journal O.D.	
PTO Side	20.91 mm (0.823 in.)
Flywheel Side	19.91 mm (0.784 in.)
Minimum Lobe Height	36.75 mm (1.447 in.)
Maximum Bearing I.D.	
Crankcase	20.08 mm (0.790 in.)
Crankcase Cover	21.08 mm (0.830 in.)
Reciprocating Balancer	
Link Rod	
Minimum Journal O.D.	53.95 mm (2.124 in.)
Maximum Small End I.D.	12.06 mm (0.475 in.)
Maximum Large End I.D.	54.12 mm (2.131 in.)
Bushing Depth	1.00 mm (0.040 in.)
Balancer Weight	
Maximum Bearing I.D.	26.10 mm (1.027 in.)
Bushing Depth	0.50 mm (0.020 in.)

Continued on next page

MX,1015CL,2 -19-23OCT95

10
15
4

Group 20—Cylinder Block and Internal Components—Continued

Item	Specification
Support Shaft	
Minimum Shaft O.D.	25.93 mm (1.021 in.)
Nuts Torque	7.3 N·m (65 lb-in.)
Piston	
Maximum Ring Groove Clearance	
Top Ring	0.17 mm (0.007 in.)
Second Ring	0.15 mm (0.006 in.)
Oil Ring	0.20 mm (0.008 in.)
Minimum Ring End Gap	0.18 mm (0.007 in.)
Maximum Ring End Gap	
Compression Rings	0.90 mm (0.035 in.)
Oil Ring Side Rails	1.30 mm (0.051 in.)
Minimum Pin O.D.	21.98 mm (0.865 in.)
Maximum Pin Bore I.D.	22.04 mm (0.868 in.)
Maximum Piston-to-Piston Pin Clearance	0.06 mm (0.002 in.)
Piston O.D.	88.83—88.85 mm (3.4885—3.498 in.)
Piston-to-Cylinder Bore Clearance	0.13—0.17 mm (0.005—0.0067 in.)
Connecting Rod	
Maximum Crankshaft Bearing I.D.	41.07 mm (1.617 in.)
Maximum Piston Pin Bearing I.D.	22.06 mm (0.868 in.)
Maximum Connecting Rod-to-Piston Pin Clearance	0.08 mm (0.003 in.)
Maximum Connecting Rod-to-Crankpin Clearance	0.14 mm (0.006 in.)
End-Cap Screw Torque	20 N·m (177 lb-in.)
Crankshaft	
Minimum PTO Side Journal O.D.	34.92 mm (1.375 in.)
Minimum Flywheel Side Journal O.D.	34.95 mm (1.376 in.)
Minimum Connecting Rod Journal O.D.	40.93 mm (1.611 in.)
Maximum Crankcase Cover Plain Bearing I.D.	35.07 mm (1.381 in.)
Ball Bearing O.D.-New Part	79.98-80.00 mm (3.149-3.150 in.)
Maximum T.I.R.	0.05 mm (0.002 in.)
End Play	0.09—0.22 mm (0.004—0.009 in.)
Cylinder Bore	
Standard Cylinder Bore I.D.	88.98—89.00 mm (3.503—3.504 in.)
Maximum Cylinder Bore I.D.	89.08 mm (3.507 in.)
Piston-to-Cylinder Bore Clearance	0.13—0.17 mm (0.005—0.0067 in.)

Continued on next page

MX,1015CL,3 -19-23OCT95

Group 20—Cylinder Block and Internal Components—Continued

Item	Specification
Rebore Cylinder	
Oversize Diameter	
0.50 mm	89.48—89.50 mm (3.523—3.524 in.)
Oil Pump	
Minimum Rotor Shaft O.D.	
Large O.D.	12.63 mm (0.497 in.)
Small O.D.	7.94 mm (0.313 in.)
Maximum Rotor Shaft Bearing I.D.	
Oil Pump Cover	12.76 mm (0.502 in.)
Crankcase Cover	8.07 mm (0.318 in.)
Outer Rotor	
Minimum Thickness	11.92 mm (0.470 in.)
Minimum O.D.	28.95 mm (1.140 in.)
Outer Rotor Bearing	
Maximum Depth	12.14 mm (0.478 in.)
Maximum I.D.	29.20 mm (1.149 in.)
Minimum Valve Spring Free Length	19.00 mm (0.750 in.)
Governor	
Shaft Height	32.2-32.8 mm (1.267-1.291 in.)
Lever Nut Torque	7 N·m (62 lb-in.)

MX,1015CL,3A -19-04MAY92

10
15
5

SECTION 20—ENGINE REPAIR—PA540A

Group 10—Blower Housing and Flywheel

Item	Specification
Flywheel Nut Torque	172 N·m (127 lb-ft)
Minimum Flywheel Screen Gap	1.50 mm (0.059 in.)

Group 15—Cylinder Head and Valves

Item	Specification
Valve Clearance	0.15 mm (0.006 in.)
Breather Air Gap	1—2 mm (0.040—0.080 in.)
Rocker Arm	
Minimum Shaft O.D.	12.94 mm (0.509 in.)
Maximum Bearing I.D.	13.07 mm (0.515 in.)
Push Rod	
Maximum Bend	0.30 mm (0.012 in.)
Valves and Springs	
Minimum Spring Free Length	
PA540A-AS00	37.50 mm (1.476 in.)
PA540A-BS00, AS01 and AS02	35.50 mm (1.398 in.)
Minimum Valve Stem O.D.	
Intake Valve	6.930 mm (0.2728 in.)
Exhaust Valve	6.915 mm (0.2722 in.)
Valve Stem O.D.-New Parts	
Intake Valve	6.972-6.987 mm (0.2745-0.2751 in.)
Exhaust Valve	6.965-6.980 mm (0.2742-0.2748 in.)
Valve Stem to Guide Clearance-New Parts	
Intake Valve	0.013-0.043 mm (0.0005-0.0017 in.)
Exhaust Valve	0.020-0.050 mm (0.0008-0.0020 in.)
Maximum Valve Guide I.D.	7.07 mm (0.278 in.)
Valve Guide I.D.-New Parts	7.000-7.015 mm (0.2756-0.2762 in.)
Valve Stem to Guide Clearance-New Parts	
Intake Valve	0.013-0.043 mm (0.0005-0.0017 in.)
Exhaust Valve	0.020-0.050 mm (0.0008-0.0020 in.)
Valve Guide Bushing Height	
PA540A-BS00, AS01 and AS02	9.5 mm (0.372 in.)
Valve Guide Bushing Finished I.D.	7.0-7.02 mm (0.275-0.276 in.)
Maximum Valve Stem Bend	0.03 mm (0.001 in.)

Continued on next page

MX,1015CL,4 -19-23OCT95

Group 15—Cylinder Head and Valves—Continued

Item	Specification
Valve Seating Surface	1.10—1.46 mm (0.043—0.057 in.)
Valve Seat and Face Angle	45°
Minimum Valve Margin	0.60 mm (0.020 in.)
Valve Narrowing Angle	30°
Cylinder Head	
Cylinder Head Flatness	0.05 mm (0.002 in.)
Studs Torque	36 N·m (27 lb-ft)
Cap Screw Torque In Sequence (Lubricated)	
Initial Torque	32 N·m (24 lb-ft)
Final Torque	52 N·m (38 lb-ft)
Spark Plug Torque	20 N·m (177 lb-in.)

Group 20—Cylinder Block and Internal Components

Item	Specification
Crankcase Cover	
Oil Capacity	
Without Filter	2.6 L (2.7 qt)
With Filter	2.8 L (2.9 qt)
Total System	3.9 L (4.1 qt)
Cap Screw Torque PA540A-BS00, AS00 and AS01	23 N·m (204 lb-in.)
Cap Screw Torque PA540A-AS02	27 N·m (239 lb-in.)
Hydrostatic Pump Cover Torque	25 N·m (226 lb-in.)
Oil Drain Plug	24 N·m (217 lb-in.)
Magnet Cap Screw Torque	6 N·m (53 lb-in.)
Camshaft	
Minimum End Journal O.D.	
PTO Side	20.91 mm (0.823 in.)
Flywheel Side	20.91 mm (0.823 in.)
Minimum Lobe Height	37.10 mm (1.461 in.)
Maximum Bearing I.D.	
Crankcase	21.08 mm (0.830 in.)
Crankcase Cover	21.08 mm (0.830 in.)
Reciprocating Balancer	
Link Rod	
Minimum Journal O.D.	57.94 mm (2.281 in.)
Maximum Small End I.D.	12.06 mm (0.475 in.)
Maximum Large End I.D.	58.15 mm (2.289 in.)
Bushing Depth	1.00 mm (0.040 in.)
Balancer Weight	
Maximum Bearing I.D.	26.10 mm (1.027 in.)
Bushing Depth	0.50 mm (0.020 in.)

Continued on next page

MX,1015CL,5 -19-23OCT95

Group 20—Cylinder Block and Internal Components—Continued

Item	Specification
Support Shaft	
Minimum Shaft O.D.	25.93 mm (1.021 in.)
Nuts Torque	7.3 N·m (65 lb-in.)
Piston	
Maximum Ring Groove Clearance	
Top Ring	0.17 mm (0.007 in.)
Second Ring	0.15 mm (0.006 in.)
Oil Ring	0.20 mm (0.008 in.)
Minimum Ring End Gap	0.18 mm (0.007 in.)
Maximum Ring End Gap	
Compression Rings	0.90 mm (0.035 in.)
Oil Ring Side Rails	1.30 mm (0.051 in.)
Minimum Pin O.D.	21.98 mm (0.865 in.)
Maximum Pin Bore I.D.	22.04 mm (0.868 in.)
Maximum Piston-to-Piston Pin Clearance	0.06 mm (0.002 in.)
Piston O.D.	88.83—88.86 mm (3.4885—3.498 in.)
Piston-to-Cylinder Bore Clearance	0.11—0.15 mm (0.0043—0.0059 in.)
Connecting Rod	
Maximum Crankshaft Bearing I.D.	41.07 mm (1.617 in.)
Maximum Piston Pin Bearing I.D.	22.06 mm (0.868 in.)
Maximum Connecting Rod-to-Piston Pin Clearance	0.08 mm (0.003 in.)
Maximum Connecting Rod-to-Crankpin Clearance	0.14 mm (0.006 in.)
End-Cap Screw Torque	20 N·m (177 lb-in.)
Crankshaft	
Minimum PTO Side Journal O.D.	37.90 mm (1.492 in.)
Minimum Flywheel Side Journal O.D.	34.95 mm (1.376 in.)
Minimum Connecting Rod Journal O.D.	40.93 mm (1.611 in.)
Maximum Crankcase Cover Plain Bearing I.D.	38.06 mm (1.498 in.)
Ball Bearing O.D.-New Part	79.98-80.00 mm (3.149-3.150 in.)
Maximum T.I.R.	0.05 mm (0.002 in.)
End Play	0.09—0.22 mm (0.004—0.009 in.)
Oil Seal Depth	0.50 mm (0.020 in.)
Cylinder Bore	
Standard Cylinder Bore I.D.	88.98—89.00 mm (3.503—3.504 in.)
Maximum Cylinder Bore I.D.	89.08 mm (3.507 in.)
Piston-to-Cylinder Bore Clearance	0.11—0.15 mm (0.0043—0.0059 in.)

Continued on next page

MX,1015CL,6 -19-23OCT95

Group 20—Cylinder Block and Internal Components—Continued

Item	Specification
Rebore Cylinder	
Oversize Diameter	
0.50 mm (0.020 in.)	89.46—89.48 mm (3.522—3.523 in.)
Oil Pump	
Minimum Rotor Shaft O.D.	12.63 mm (0.497 in.)
Maximum Rotor Shaft Bearing I.D.	12.76 mm (0.502 in.)
Outer Rotor	
Minimum Thickness	9.92 mm (0.391 in.)
Minimum O.D.	40.47 mm (1.596 in.)
Outer Rotor Bearing	
Maximum Depth	10.17 mm (0.401 in.)
Maximum I.D.	40.77 mm (1.605 in.)
Minimum Valve Spring Free Length	19.00 mm (0.750 in.)
Governor	
Shaft Height	32.2-32.8 mm (1.267-1.291 in.)
Lever Nut Torque	7 N·m (62 lb-in.)

MX,1015CL,6A -19-23OCT95

SECTION 30—FUEL AND AIR REPAIR

Item	Specification
Breather	
Air Gap	1—2 mm (0.040—0.080 in.)

MX,1015CL,6B -19-23OCT95

SECTION 40—ELECTRICAL

Item	Specification
PTO Clutch Clearance	0.46 mm (0.018 in.)
PTO Mounting Cap Screw Torque	
Ogura	56 N·m (45 lb-ft)
Warner	75 N·m (55 lb-ft)
Starter Brush Length (Minimum)	
PA420A	6 mm (0.240 in.)
PA540A	10.5 mm (0.413 in.)
Ignition Coil Air Gap	0.30 mm (0.012 in.)

MX,1015CL,7 -19-23OCT95

SECTION 50—POWER TRAIN

10
15
10

Item	Specification
Variable Displacement Pump	
Outer Rotor O.D. (Minimum)	40.45 mm (1.593 in.)
Outer Rotor Thickness (Minimum)	12.95 mm (0.510 in.)
Pump Housing I.D. (Maximum)	40.80 mm (1.606 in.)
Pump Housing Depth (Maximum)	13.15 mm (0.518 in.)
Pump Cover Torque	
Initial	18. N·m (159 lb-in.)
Final	25.5 N·m (225 lb-in.)
Short Cap Screw Torque-PA420A/PA540A-AS01 and AS02	20 N·m (177 lb-in.)
Oil Line, Joint Fitting	100 N·m (74 lb-ft)
Oil Line, Joint Nut	79 N·m (58 lb-ft)
Relief Valve Spring Free Length (Minimum)	32 mm (1.26 in.)
Check Valve Spring Free Length (Minimum)	14 mm (0.55 in.)
Relief Valve Screw Torque	24.5 N·m (217 lb-in.)
Check Valve Plug	20 N·m (177 lb-in.)
Check Valve Screw	20 N·m (177 lb-in.)
Swashplate Bearing Cap Screw Torque-PA420A/PA540A-AS01 and AS02	1.6 N·m (12 lb-in.)
Fixed Displacement Pump Cylinder	
Piston O.D. (Minimum)	19.98 mm (0.787 in.)
Piston Ring-to-Groove Clearance (Maximum)	0.60 mm (0.024 in.)
Piston Spring Free Length (Minimum)	27 mm (1.063 in.)
Cylinder Bore I.D. (Maximum)	20.05 mm (0.789 in.)
Cylinder Spring Free Length (Minimum)	34.5 mm (1.36 in.)
Cylinder Spring Free Length (NEW)	
PA420A/PA540A-AS00 and BS00	45.6 mm (1.80 in.)
PA420A/PA540A-AS01 and AS02	44.7 mm (1.76 in.)
Shaft Journal O.D. (Minimum)	11.90 mm (0.46 in.)
Control Shaft Cap Screws	24.5 N·m (217 lb-in.)
Axle Assemblies	
Axle Housing Seal Depth	2 mm (0.079 in.)
Transmission Axle	
Run-out (Maximum)	1.6 mm (0.06 in.)
Oil Seal Journal O.D. (Minimum)	25 mm (0.984 in.)
Needle Bearing Journal O.D. (Minimum)	24.9 mm (0.982 in.)
Differential Axle	
Run-out (Maximum)	0.6 mm (0.024 in.)
Axle Housing Cap Screw	
Initial Torque	30 N·m (22 lb-ft)
Final Torque	42 N·m (31 lb-ft)
Isolator Mount Cap Screw Torque	25.5 N·m (255 lb-in.)

MX,1015CL,7A -19-23OCT95

SECTION 50—POWER TRAIN

Item	Specification
Transmission	
Input Shaft	
Large Journal (Minimum)	39.97 mm (1.573 in.)
Small Journal (Minimum)	31.94 mm (1.258 in.)
Fixed Displacement Motor Cylinder	
Piston O.D. (Minimum)	19.98 mm (0.787 in.)
Piston Ring-to-Groove Clearance (Maximum)	0.60 mm (0.024 in.)
Piston Spring Free Length (Minimum)	27 mm (1.063 in.)
Cylinder Bore I.D. (Maximum)	20.05 mm (0.789 in.)
Retaining Spring Free Length (Minimum)-PA420A/PA540A-AS00 and BS00	42 mm (1.65 in.)
Motor Housing Plug Torque	17.5 N·m (155 lb-in.)
Pipe Joint Torque	100 N·m (74 lb-ft)
Free-Wheeling Valve	
Push Rod Movement	8 mm (0.31 in.)
Sleeve Torque	41 N·m (30 lb-ft)
Sleeve Bolt Torque	31 N·m (23 lb-ft)
Differential	
Shaft O.D. (Minimum)	13.70 mm (0.539 in.)
Bevel Gear Journal O.D. (Minimum)	29.91 mm (1.178 in.)
Pinion Gear I.D. (Maximum)	14.35 mm (0.565 in.)
Case, Bevel Gear Bore I.D. (Maximum)	30.08 mm (1.184 in.)
Case, Ball Bearing Journal O.D. (Minimum)	55.93 mm (2.202 in.)
Case, Cap Screw Torque	25.5 N·m (225 lb-in.)

MX,1015CL,7B -19-23OCT95

SECTION 60—STEERING

Item	Specification
Draglink Rod Ball Joint Nut Torque	34 N·m (25 lb-ft)
Steering Arm Ball Joint Nut Torque	37 N·m (27 lb-ft)
Front Wheel Cap Screw Torque	50 N·m (37 lb-ft)

MX,1015CL,8 -19-23OCT95

SECTION 80—MISCELLANEOUS

Item	Specification
38-Inch Mower Deck	
Spindle Mounting Nut Torque	25 N·m (221 lb-in.)
Blade Cap Screw Torque	75 N·m (55 lb-ft)
Spindle Sheave Nut	140 N·m (103 lb-ft)
46-Inch Mower Deck	
Spindle Mounting Nut Torque	25 N·m (221 lb-in.)
Blade Cap Screw Torque	75 N·m (55 lb-ft)
Spindle Rolling Drag Torque (Maximum)	0.07 N·m (0.6 lb-in.)
48-Inch Mower Deck	
Spindle Mounting Nut Torque	26 N·m (19 lb-ft)
Blade Cap Screw Torque	68 N·m (50 lb-ft)
Spindle Sheave Nut	163 N·m (120 lb-ft)
Lower Seal Depth	7.8 mm (0.31 in.)
Jack Sheave Nut Torque	136 N·m (100 lb-ft)
Tensioning Idle Sheave Nut Torque	27 N·m (20 lb-ft)

MX,1015CL,8A -19-23OCT95

TUNE-UP SPECIFICATIONS

	F510, PA420A ENGINE	F525, PA540A ENGINE
Spark Plug Type	Champion RN11YC, NGK-BPR5ES, John Deere M802138	Champion RN11YC, NGK-BPR5ES, John Deere M802138
Spark Plug Gap	0.75 mm (0.030 in.)	0.75 mm (0.030 in.)
Spark Plug Torque	20 N·m (177 lb-in.)	20 N·m (177 lb-in.)
Slow Idle Speed	1450 RPM	1450 RPM
Fast Idle Speed	3250 ±50 RPM	3250 ±50 RPM

MX,1015CL,9 -19-23OCT95

TUNE-UP ADJUSTMENTS

1. Clean engine cooling fins.
2. Clean or replace air filter.
3. Replace fuel filter.
4. Check electrolyte level.
5. Clean, regap or replace spark plug.
6. Check charging system output.
7. Check engine compression.
8. Adjust carburetor and throttle linkage.
9. Adjust governor.
10. Check and clean crankcase breather.
11. Check crankcase vacuum.
12. Adjust brake.
13. Check transaxle and steering linkage.
14. Check tire pressure.

MX,1015CL,10 -19-23OCT95

10
15
13

METRIC BOLT AND CAP SCREW TORQUE VALUES

10
15
14

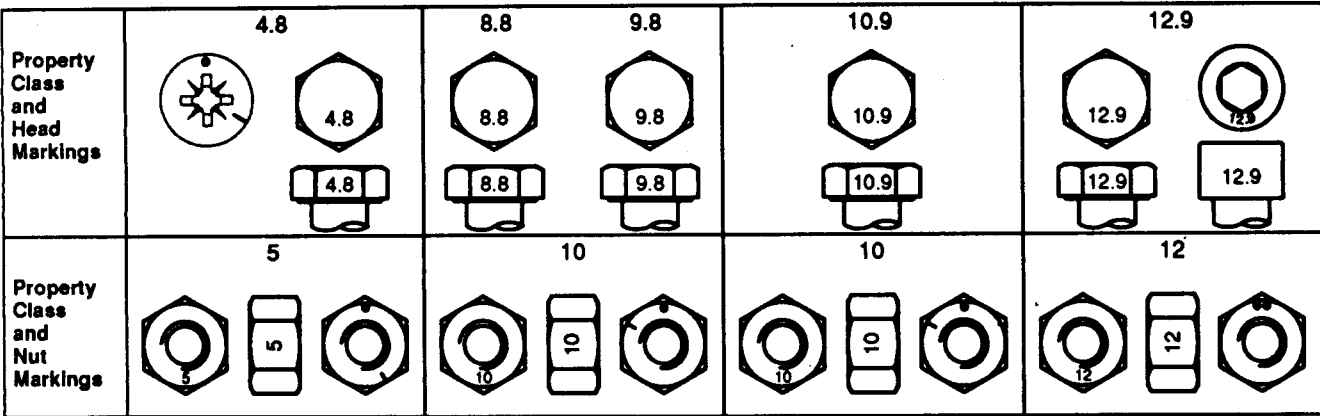

TS1163 -19-04/MAR91

Size	Class 4.8				Class 8.8 or 9.8				Class 10.9				Class 12.9			
	Lubricated ^a		Dry ^a		Lubricated ^a		Dry ^a		Lubricated ^a		Dry ^a		Lubricated ^a		Dry ^a	
	N-m	lb-ft	N-m	lb-ft	N-m	lb-ft	N-m	lb-ft	N-m	lb-ft	N-m	lb-ft	N-m	lb-ft	N-m	lb-ft
M6	4.8	3.5	6	4.5	9	6.5	11	8.5	13	9.5	17	12	15	11.5	19	14.5
M8	12	8.5	15	11	22	16	28	20	32	24	40	30	37	28	47	35
M10	23	17	29	21	43	32	55	40	63	47	80	60	75	55	95	70
M12	40	29	50	37	75	55	95	70	110	80	140	105	130	95	165	120
M14	63	47	80	60	120	88	150	110	175	130	225	165	205	150	260	190
M16	100	73	125	92	190	140	240	175	275	200	350	255	320	240	400	300
M18	135	100	175	125	260	195	330	250	375	275	475	350	440	325	560	410
M20	190	140	240	180	375	275	475	350	530	400	675	500	625	460	800	580
M22	260	190	330	250	510	375	650	475	725	540	925	675	850	625	1075	800
M24	330	250	425	310	650	475	825	600	925	675	1150	850	1075	800	1350	1000
M27	490	360	625	450	950	700	1200	875	1350	1000	1700	1250	1600	1150	2000	1500
M30	675	490	850	625	1300	950	1650	1200	1850	1350	2300	1700	2150	1600	2700	2000
M33	900	675	1150	850	1750	1300	2200	1650	2500	1850	3150	2350	2900	2150	3700	2750
M36	1150	850	1450	1075	2250	1650	2850	2100	3200	2350	4050	3000	3750	2750	4750	3500

DO NOT use these values if a different torque value or tightening procedure is given for a specific application. Torque values listed are for general use only. Check tightness of fasteners periodically.

Shear bolts are designed to fail under predetermined loads. Always replace shear bolts with identical property class.

Fasteners should be replaced with the same or higher property class. If higher property class fasteners are used, these should only be tightened to the strength of the original.

^a "Lubricated" means coated with a lubricant such as engine oil, or fasteners with phosphate and oil coatings. "Dry" means plain or zinc plated without any lubrication.

Make sure fasteners threads are clean and that you properly start thread engagement. This will prevent them from failing when tightening.

Tighten plastic insert or crimped steel-type lock nuts to approximately 50 percent of the dry torque shown in the chart, applied to the nut, not to the bolt head. Tighten toothed or serrated-type lock nuts to the full torque value.

UNIFIED INCH BOLT AND CAP SCREW TORQUE VALUES

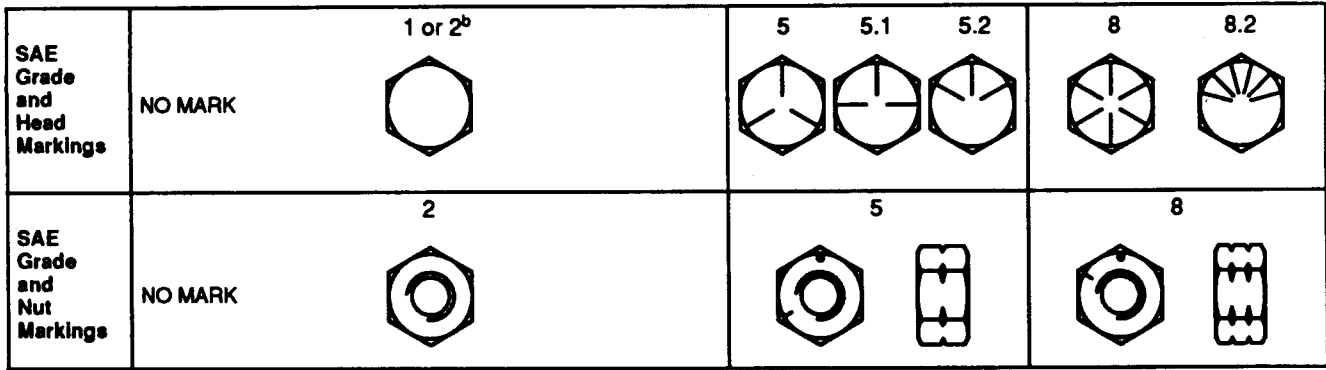

Size	Grade 1				Grade 2 ^b				Grade 5, 5.1, or 5.2				Grade 8 or 8.2			
	Lubricated ^a		Dry ^a		Lubricated ^a		Dry ^a		Lubricated ^a		Dry ^a		Lubricated ^a		Dry ^a	
	N-m	lb-ft	N-m	lb-ft	N-m	lb-ft	N-m	lb-ft	N-m	lb-ft	N-m	lb-ft	N-m	lb-ft	N-m	lb-ft
1/4	3.7	2.8	4.7	3.5	6	4.5	7.5	5.5	9.5	7	12	9	13.5	10	17	12.5
5/16	7.7	5.5	10	7	12	9	15	11	20	15	25	18	28	21	35	26
3/8	14	10	17	13	22	16	27	20	35	26	44	33	50	36	63	46
7/16	22	16	28	20	35	26	44	32	55	41	70	52	80	58	100	75
1/2	33	25	42	31	53	39	67	50	85	63	110	80	120	90	150	115
9/16	48	36	60	45	75	56	95	70	125	90	155	115	175	130	225	160
5/8	67	50	85	62	105	78	135	100	170	125	215	160	240	175	300	225
3/4	120	87	150	110	190	140	240	175	300	225	375	280	425	310	550	400
7/8	190	140	240	175	190	140	240	175	490	360	625	450	700	500	875	650
1	290	210	360	270	290	210	360	270	725	540	925	675	1050	750	1300	975
1-1/8	400	300	510	375	400	300	510	375	900	675	1150	850	1450	1075	1850	1350
1-1/4	570	425	725	530	570	425	725	530	1300	950	1650	1200	2050	1500	2600	1950
1-3/8	750	550	950	700	750	550	950	700	1700	1250	2150	1550	2700	2000	3400	2550
1-1/2	1000	725	1250	925	990	725	1250	930	2250	1650	2850	2100	3600	2650	4550	3350

DO NOT use these values if a different torque value or tightening procedure is given for a specific application. Torque values listed are for general use only. Check tightness of fasteners periodically.

Shear bolts are designed to fail under predetermined loads. Always replace shear bolts with identical grade.

^a "Lubricated" means coated with a lubricant such as engine oil, or fasteners with phosphate and oil coatings. "Dry" means plain or zinc plated without any lubrication.

^b Grade 2 applies for hex cap screws (not hex bolts) up to 152 mm (6-in.) long. Grade 1 applies for hex cap screws over 152 mm (6-in.) long, and for all other types of bolts and screws of any length.

Fasteners should be replaced with the same or higher grade. If higher grade fasteners are used, these should only be tightened to the strength of the original.

Make sure fasteners threads are clean and that you properly start thread engagement. This will prevent them from failing when tightening.

Tighten plastic insert or crimped steel-type lock nuts to approximately 50 percent of the dry torque shown in the chart, applied to the nut, not to the bolt head. Tighten toothed or serrated-type lock nuts to the full torque value.

GASOLINE



TS227 -UN-23AUG88

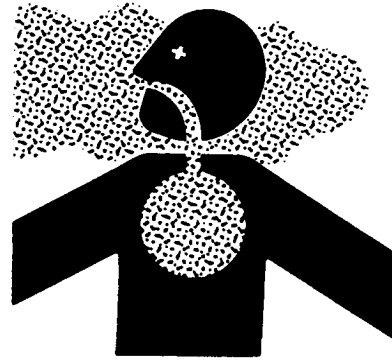

TS220 -UN-23AUG88

 **CAUTION:** Gasoline is **HIGHLY FLAMMABLE**, handle it with care.

DO NOT refuel machine while:

- indoors, always fill gas tank outdoors;
- machine is near an open flame or sparks;
- engine is running, **STOP** engine;
- engine is hot, allow it to cool sufficiently first;
- smoking.

Help prevent fires:

- fill gas tank to bottom of filler neck only;
- be sure fill cap is tight after fueling;
- clean up any gas spills **IMMEDIATELY**;
- keep machine clean and in good repair—free of excess grease, oil, debris, and faulty or damaged parts;
- any storage of machines with gas left in tank should be in an area that is well ventilated to prevent possible igniting of fumes by an open flame or spark, this includes any appliance with a pilot light.

To prevent fire or explosion caused by **STATIC ELECTRIC DISCHARGE** during fueling:

- **ONLY** use a clean, approved **POLYETHYLENE PLASTIC** fuel container and funnel **WITHOUT** any metal screen or filter.

To avoid engine damage:

- **DO NOT** mix oil with gasoline;
- **ONLY** use fresh, clean gasoline;
- fill gas tank at the end of each day's operation to help prevent condensation from forming inside a partially filled tank;
- keep up with specified service intervals.

GASOLINE SPECIFICATIONS:

Unleaded gasoline with a minimum octane rating (anti-knock index) of 87 is recommended because it burns cleaner and leaves less unburned deposits in the engine combustion chamber.

Use of alternative oxygenated, gasohol blended, unleaded gasoline is acceptable as long as:

- the ethyl or grain alcohol blends **DO NOT** exceed 10% by volume or
- methyl tertiary butyl ether (MTBE) blends **DO NOT** exceed 15% by volume.

IMPORTANT: DO NOT use **METHANOL** gasolines because **METHANOL** is harmful to the environment and to your health.

MX,1020CL,1A -19-23OCT95

GASOLINE STORAGE

10
20
2

IMPORTANT: Keep all dirt, scale, water or other foreign material out of gasoline.

Keep gasoline in a safe, protected area and in a clean, properly marked "UNLEADED GASOLINE" container. DO NOT use de-icers to attempt to remove water from gasoline. DO NOT depend on fuel filters to remove water from gasoline. It is recommended that a water separator be installed in the storage tank outlet.

BE SURE to properly discard unstable or contaminated gasoline.

Whether the unit is either stored or used during the winter, it is recommended that you add John Deere Gasoline Conditioner and Stabilizer (TY15977) or an equivalent to the gasoline. BE SURE to follow directions on container and properly discard empty container.

It is recommended that gasoline be stored ONLY in an approved POLYETHYLENE PLASTIC container WITHOUT any metal screen or filter. This will help prevent any accidental sparks from occurring.

MX,1020CL,2 -19-23OCT95

4-CYCLE GASOLINE ENGINE AND HYDROSTATIC TRANSMISSION OIL—NORTH AMERICA

NOTE: The F510 and F525 Residential Front Mowers are unique machines in that the engine and hydrostatic transmission are a unitized concept that share the same oil reservoir.

Use appropriate oil viscosity based on the expected air temperature range during the period between recommended oil changes.

The following John Deere oil is **PREFERRED**:

- **TORQ—GARD® SUPREME—SAE 5W-30.**

Other oils may be used if above John Deere oil is not available, provided they meet one of the following specifications:

- **SAE 5W-30—API Service Classifications SH and SG.**

IMPORTANT: Arctic oils (such as SAE 0W-30 or Military Specification MIL-L-46167B) may be used if temperatures fall below -30°C (-22°), but reduce the service interval by 50%. For prolonged operation under heavy load in temperatures above 40° (104°) reduce service interval by 50%.

John Deere Dealers: You may want to cross-reference the following publications to recommend the proper oil for your customers:

- Module DX,ENOIL2 in JDS-G135;
- Section 530, Lubricants & Hydraulics, of the John Deere Merchandise Sales Guide;
- Lubrication Sales Manual PI7032;
- Lawn & Grounds Care Tune-Up Guide PI672.

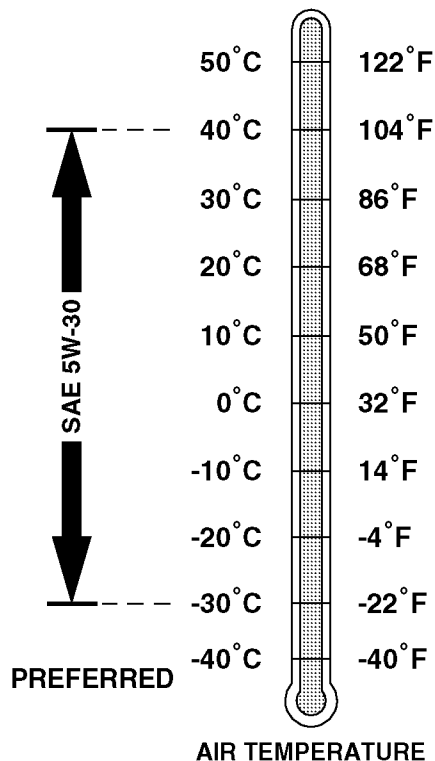

10
20
3

M83052 -19-18OCT95

MX,1020CL,3 -19-23OCT95

4-CYCLE GASOLINE ENGINE AND HYDROSTATIC TRANSMISSION OIL—EUROPE

NOTE: The F510 and F525 Residential Front Mowers are unique machines in that the engine and hydrostatic transmission are a unitized concept that share the same oil reservoir.

Use appropriate oil viscosity based on the expected air temperature range during the period between recommended oil changes.

The following John Deere oils are **PREFERRED**:

- **TORQ-GARD® SUPREME—SAE 5W-30;**
- **UNI-GARD™—SAE 5W-30.**

Other oils may be used if above John Deere oils are not available, provided they meet one of the following specifications:

- **CCMC Specification G5 and G4.**

IMPORTANT: Arctic oils (such as SAE 0W-30 or Military Specification MIL—L—46167B) may be used if temperatures fall below -30°C (-22°F), but reduce the service interval by 50%. For prolonged operation under heavy load in temperatures above 40°C (104°F) reduce service interval by 50%.

John Deere Dealers: You may want to cross-reference the following publications to recommend the proper oil for your customers:

- Module DX,ENOIL2 in JDS—G135;
- Section 530, Lubricants & Hydraulics, of the John Deere Merchandise Sales Guide.

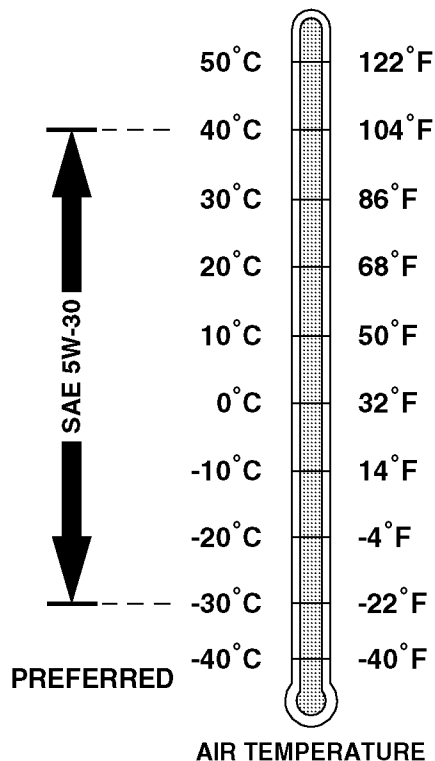

M83052 -19-18OCT95

MX,1020CL,4 -19-23OCT95

BREAK-IN OIL—NORTH AMERICA

IMPORTANT: ONLY use this specified break-in oil in rebuilt or remanufactured engines for the first 5 hours maximum. DO NOT use oils with heavier viscosity weights than SAE 5W-30 or oils meeting specifications API SG or SH, these oils will not allow rebuilt or remanufactured engines to break-in properly.

The following John Deere oil is **PREFERRED**:

- **BREAK-IN ENGINE OIL.**

John Deere BREAK-IN ENGINE OIL is formulated with special additives for aluminum and cast iron type engines to allow the power cylinder components (pistons, rings, and liners as well) to “wear-in” while protecting other engine components, valve train and gears, from abnormal wear.

Engine rebuild instructions should be followed closely to determine if special requirements are necessary.

John Deere BREAK-IN ENGINE OIL is also recommended for non-John Deere engines, both aluminum and cast iron types.

If this preferred John Deere Oil is not available, use a break-in engine oil meeting one of the following specifications during the first 5 hours of operation:

- **API Service Classification SE.**

After the break-in period, use the **PREFERRED** John Deere oil as recommended for the appropriate type engine.

John Deere Dealers: You may want to cross-reference the following publications to recommend the proper oil for your customers:

- Module DX, ENOIL4 in JDS-G135;
- Section 530, Lubricants & Hydraulics, of the John Deere Merchandise Sales Guide;
- Lubrication Sales Manual PI7032.

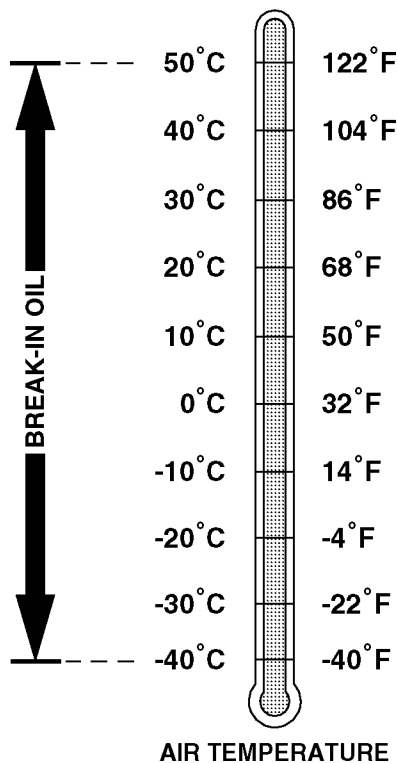

M83053 -19-18OCT95

10
20
5

BREAK-IN OIL—EUROPE

IMPORTANT: ONLY use this specified break-in oil in rebuilt or remanufactured engines for the first 5 hours maximum. DO NOT use oils with viscosity weights than SAE 5W-30 or oils meeting CCMC specifications G5—these oils will not allow rebuilt or remanufactured engines to break-in properly.

The following John Deere oil is **PREFERRED**:

- **BREAK-IN ENGINE OIL.**

John Deere BREAK-IN ENGINE OIL is formulated with special additives for aluminum and cast iron type engines to allow the power cylinder components (pistons, rings, and liners as well) to “wear-in” while protecting other engine components, valve train and gears, from abnormal wear.

Engine rebuild instructions should be followed closely to determine if special requirements are necessary.

John Deere BREAK-IN ENGINE OIL is also recommended for non-John Deere engines, both aluminum and cast iron types.

If above preferred John Deere break-in engine oil is not available, use a break-in engine oil meeting one of the following specifications during the first 5 hours of operation:

- **CCMC Specification G4.**

After the break-in period, use the **PREFERRED** John Deere oil as recommended for the appropriate type engine.

John Deere Dealers: You may want to cross-reference the following publications to recommend the proper oil for your customers:

- Module DX, ENOIL4 in JDS-G135;
- Section 530, Lubricants & Hydraulics, of the John Deere Merchandise Sales Guide.

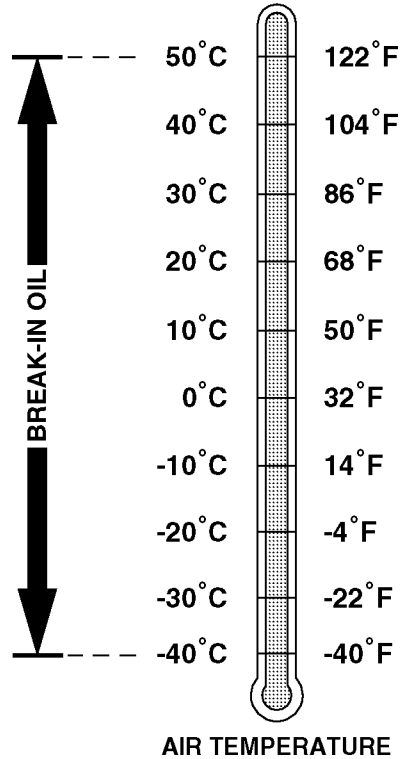

M83053 -19-18OCT95

GREASE—NORTH AMERICA

IMPORTANT: ONLY use the specified greases in this application. DO NOT mix any other greases in this application. DO NOT use any BIO-GREASE in this application.

The following John Deere greases are **PREFERRED**:

- **MOLY HIGH-TEMPERATURE EP GREASE—NLGI Grade 2, JDM J25C.**

The following John Deere grease is also recommended if the above preferred grease is not available:

- **HIGH-TEMPERATURE EP GREASE—NLGI Grade 2 JDM J13E4.**

Other greases may be used if above preferred John Deere greases are not available, provided they meet one of the following specifications:

- **NLGI Grade 2, JDM J25C (preferred);**
- **NLGI Grade 2, JDM J13E4.**

IMPORTANT: If minimum temperature should fall below -30°C (-22°F), the transmission grease must be heated to at least five degrees above the lower limit before start-up or transmission may be damaged. For prolonged operation under heavy load in temperatures above 40°C (104°F) reduce service interval by 50%.

John Deere Dealers: You may want to cross-reference the following publications to recommend the proper grease for your customers:

- Module DX,GREA1 in JDS-G135;
- Section 530, Lubricants & Hydraulics, of the John Deere Merchandise Sales Guide;
- the Lubrication Sales Manual PI7032 (1-95);
- the Lawn & Grounds Care Tune-Up Guide PI672 (1-95).

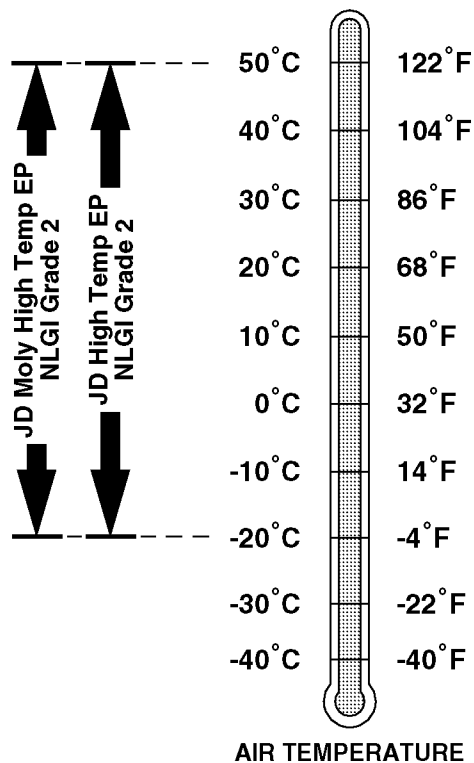

AIR TEMPERATURE

M83054 -19-18OCT95

10
20
7

GREASE—EUROPE

IMPORTANT: ONLY use a quality NLGI Grade 2 gear grease in this application. DO NOT mix any other greases in this application. DO NOT use any BIO-GREASE in this application.

The following John Deere gear grease is **PREFERRED**:

- **GREASE-GARD—JDM J25C.**

Other gear greases may be used if above recommended John Deere gear greases are not available, provided they meet the following specification:

- **NLGI Grade 2, JDM J25C.**

IMPORTANT: If minimum temperature should fall below -30°C (-22°F), the transmission grease must be heated to at least five degrees above the lower limit before start-up or transmission may be damaged. For prolonged operation under heavy load in temperatures above 50°C (122°F) reduce service interval by 50%.

John Deere Dealers: You may want to cross-reference the following publications to recommend the proper grease for your customers:

- Module DX,GREA1 in JDS-G135;
- Section 530, Lubricants & Hydraulics, of the John Deere Merchandise Sales Guide.

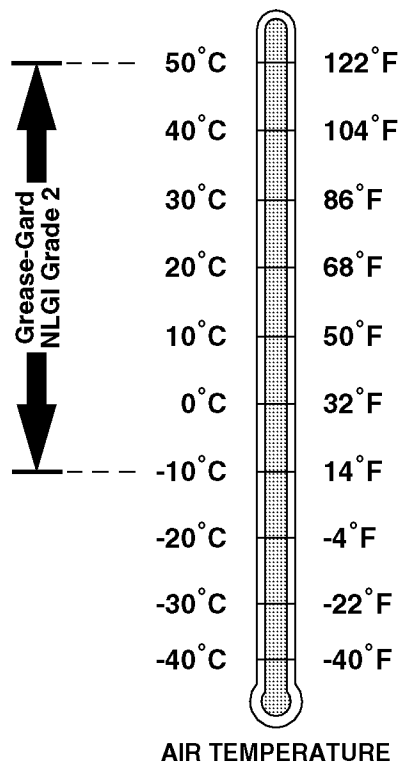

M83055 -19-18OCT95

MX,1020CL,8 -19-23OCT95

ALTERNATIVE LUBRICANTS

Conditions in certain geographical areas outside the United States and Canada may require different lubricant recommendations than the ones printed in this technical manual or the operator's manual. Consult with your John Deere Dealer, or Sales Branch, to obtain the alternative lubricant recommendations.

IMPORTANT: Use of alternative lubricants could cause reduced life of the component. If alternative lubricants are to be used, it is recommended that the factory fill be thoroughly removed before switching to any alternative lubricant.

MX,1020CL,9 -19-23OCT95

SYNTHETIC LUBRICANTS

Synthetic lubricants may be used in John Deere equipment if they meet the applicable performance requirements (industry classification and/or military specification) as shown in this manual.

The recommended temperature limits and service or lubricant change intervals should be maintained as shown in the operator's manual, unless otherwise stated on lubricant label.

Avoid mixing different brands, grades, or types of oil. Oil manufacturers blend additives in their oils to meet certain specifications and performance requirements. Mixing different oils can interfere with the proper functioning of these additives and degrade lubricant performance.

MX,1020CL,10 -19-23OCT95

LUBRICANT STORAGE

All machines operate at top efficiency only when clean lubricants are used. Use clean storage containers to handle all lubricants. Store them in an area protected from dust, moisture, and other contamination. Store drums on their sides. Make sure all containers are properly marked as to their contents. Dispose of all old, used containers and their contents properly.

MX,1020CL,11 -19-23OCT95

MIXING OF LUBRICANTS

In general, avoid mixing different brands or types of lubricants. Manufacturers blend additives in their lubricants to meet certain specifications and performance requirements. Mixing different lubricants can interfere with the proper functioning of these additives and lubricant properties which will downgrade their intended specified performance.

MX,1020CL,12 -19-23OCT95

OIL FILTERS

IMPORTANT: Filtration of oils is critical to proper lubrication performance. Always change filters regularly.

The following John Deere oil filters are **PREFERRED**:

- **AUTOMOTIVE AND LIGHT TRUCK ENGINE OIL FILTERS.**

Most John Deere filters contain pressure relief and anti-drainback valves for better engine protection. Other oil filters may be used if above recommended John Deere oil filters are not available, provided they meet the following specification:

- **ASTB Tested In Accordance With SAE J806.**

John Deere Dealers: You may want to cross-reference the following publications to recommend the proper oil filter for your customers:

- Module DX,FILT in JDS-G135;
- Section 540, Lubricants & Hydraulics, of the John Deere Merchandise Sales Guide;
- Lawn & Grounds Care Tune-Up Guide PI672.

MX,1020CL,13 -19-23OCT95

SERIAL NUMBER INFORMATION

When working on machines or components that are covered by warranty, it is IMPORTANT that you include the machine's Product Identification Number and the Component Serial Number on the warranty claim form.

The location of Component Serial Number plates are shown below.

MX,1025CL,1 -19-23OCT95

RECORD PRODUCT IDENTIFICATION NUMBER

The mower's 13 digit product identification number is located on the left-hand rear corner of the frame.



M61965
-UN-15MAR89

MX,1025CL,2 -19-04MAY92

RECORD ENGINE SERIAL NUMBER

The engine serial number (A) is located on the left side of the blower housing.



M62297
-UN-15MAR89

MX,1025CL,3 -19-04MAY92

Section 20 ENGINE REPAIR

Contents

	Page		Page
Group 05—Remove and Install Engine			
Remove Engine	20-05-1	Remove and Install Crankcase Cover . . .	20-20-3
Repair Isolators	20-05-3	Crankcase Cover Magnet	20-20-4
Install Engine	20-05-4	Camshaft	
		Remove and Install	20-20-4
		Inspect	20-20-5
		Inspect Bearings	20-20-6
		Inspect Automatic Compression Release .	20-20-7
		Remove/Inspect/Install Tappets	20-20-7
		Reciprocating Balancer	
		Remove and Install	20-20-8
		Disassemble and Assemble	20-20-9
		Inspect	20-20-10
		Replace Bushings	20-20-11
		Piston and Connecting Rod	
		Remove and Install	20-20-12
		Disassemble, Inspect and Assemble . . .	20-20-13
		Piston Rings	
		Remove and Install	20-20-13
		Check End Gap	20-20-14
		Inspect	
		Piston	20-20-14
		Analyze	
		Piston Ring Wear	20-20-16
		Piston Wear	20-20-18
		Connecting Rod	20-20-20
		Crankshaft and Connecting Rod Wear . . .	20-20-21
		Crankshaft	
		Remove, Inspect and Install	20-20-22
		Regrind	20-20-23
		Inspect Plain Bearing	20-20-24
		Inspect Ball Bearing	20-20-24
		Check Alignment (TIR)	20-20-25
		Measure End Play	20-20-25
		Adjust End Play	20-20-26
		Inspect	
		Oil Seals	20-20-27
		Cylinder Block	20-20-28
		Deglaze Cylinder Bore	20-20-29
		Rebore Cylinder Block	20-20-30
		Oil Pump—PA420A	
		Disassemble and Assemble	20-20-31
		Inspect	20-20-32
Group 10—Blower Housing and Flywheel			
Engine Configuration Chart	20-10-1		
Service Parts Kits	20-10-1		
Remove and Install Blower Housing	20-10-2		
Flywheel Screen Adjustment	20-10-2		
Remove and Install Flywheel	20-10-3		
Group 15—Cylinder Head and Valves			
Engine Configuration Chart	20-15-1		
Essential Tools	20-15-1		
Service Equipment and Tools	20-15-1		
Other Materials	20-15-2		
Service Parts Kits	20-15-2		
Rocker Arm Assembly—PA420A/PA540A			
Remove and Install	20-15-3		
Inspect	20-15-3		
Cylinder Head Assembly			
Remove and Install	20-15-4		
Valves and Springs			
Remove and Install	20-15-6		
Inspect and Replace Stem Seals	20-15-6		
Inspect			
Valve Springs	20-15-7		
Cylinder Head	20-15-7		
Replace Cylinder Head Studs	20-15-7		
Valves			
Inspect	20-15-8		
Analyze	20-15-9		
Valve Guides	20-15-11		
Replace Valve Guide Bushings	20-15-11		
Recondition Valve Seats	20-15-13		
Lap	20-15-14		
Check Valve Clearance	20-15-14		
Group 20—Cylinder Block and Internal Components			
Engine Configuration Chart	20-20-1		
Other Materials	20-20-1		
Service Parts Kits	20-20-2		

Continued on next page

Page

Oil Pump—PA540A
 Disassemble and Assemble 20-20-34
 Inspect 20-20-35
Remove, Inspect and Install Oil Filter
 Manifold 20-20-38
Inspect and Replace
 Governor 20-20-38
 Governor Arm 20-20-39

20

REMOVE ENGINE

1. Disconnect battery cables. (Disconnect negative cable at engine first.)

2. Remove mower deck.

NOTE: Oil reservoir capacity is approximately 3.4 L (3.5 qt).

3. Remove drain plug (A) and drain oil reservoir.

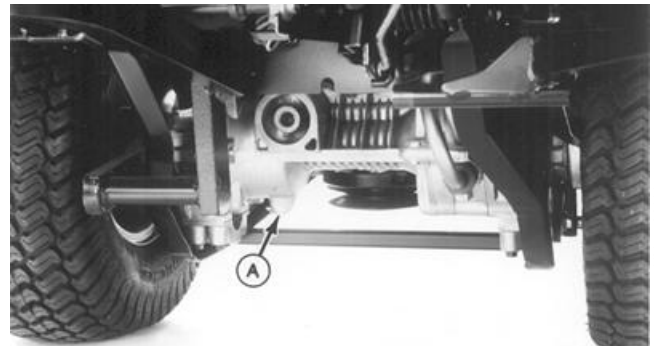

MX,2005CL,A1 -19-23OCT95

M81636 -JUN-23MAY95

20-05-1

4. Remove front wheels. (See Remove and Install Wheels in Section 60, Group 10.)

5. Remove snap ring (A). Remove mower deck arms.

6. Remove seat platform (B). (See Remove and Install Seat Platform in Section 80, Group 15.)

7. Remove fenders. (See Right Fender—Service Removal and Left Fender Replacement in Section 80, Group 15.)

8. Close fuel shut-off valve (C).



MX,2005CL,A1A -19-23OCT95

M53037 -JUN-13APR89

Remove and Install Engine/Remove Engine

9. Disconnect wires (C) and (D).
10. Disconnect harness (A).
11. Disconnect linkages (B) and (E).
12. Remove shield, cap screws (F) and muffler.
13. Remove braces (I).
14. Remove bracket (H).
15. Disconnect and drain fuel inlet line at fuel pump.
16. Remove cap screws (G).
17. Remove engine.

- A—Engine Harness
- B—Brake Linkage
- C—Purple Wire (Solenoid)
- D—Red Wires (Battery Cable and Pigtail)
- E—Shift Linkage
- F—Muffler Cap Screws
- G—Engine Mount Cap Screws (3)
- H—Fender Bracket
- I—Frame Braces (2)

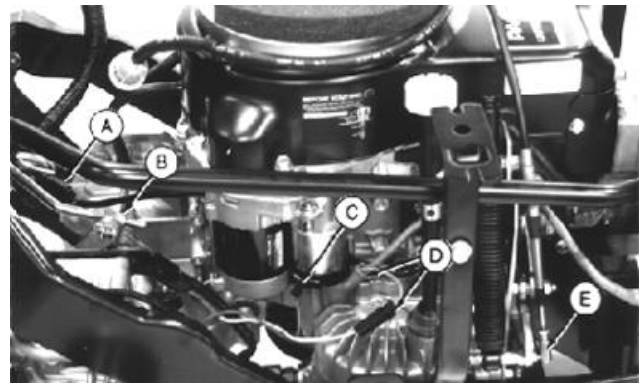

M81620 -JUN-29APR95

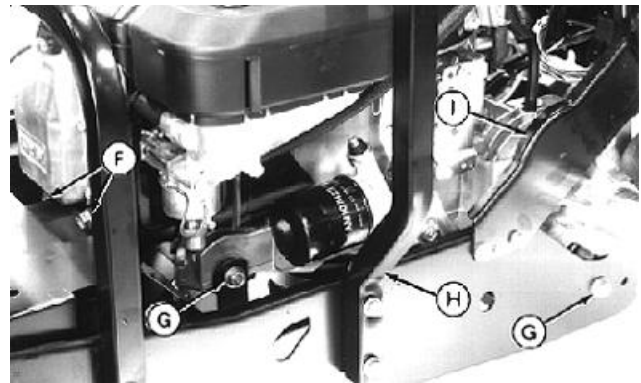

M81621 -JUN-29APR95

MX,2005CL,A2 -19-23OCT95

REPAIR ISOLATORS

1. Inspect isolators for wear, oil contamination, and damage. Replace isolators as needed.

IMPORTANT: Misalignment or oil applied to the isolators will reduce the dampening of the isolators. Be careful to install the isolators correctly.

2. Push PTO clutch isolator into crankcase cover until surface (A) is even with outer flange (B) of the seat.

3. Install the engine mount isolator with the letters "UP" (C) away from the mounting bracket (D). Also the molded rubber projection (E) must be centered between the marks (F), if equipped, or centered on the mounting bracket. Tighten mounting bracket cap screws.

4. Install the axle mount isolators with the letters "UP" (G) aligned with the axle housing rib (H). Push the isolator into the housing until seated against the housing shoulder (I). Tighten mounting bracket cap screws.

- A—PTO Clutch Isolator Surface
- B—Seat Outer Flange
- C—Letters "UP"
- D—Mounting Bracket
- E—Molded Rubber Projection
- F—Mounting Bracket Marks
- G—Letters "UP"
- H—Axle Housing Rib
- I—Housing Shoulder

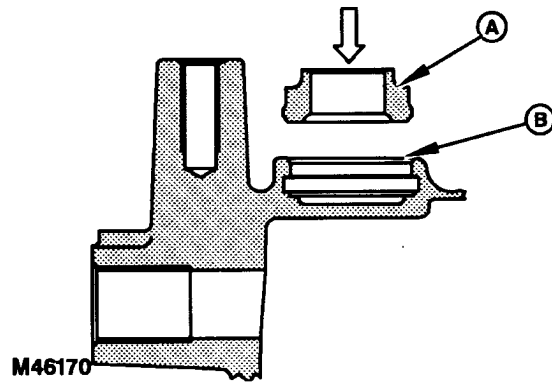

PTO Clutch Isolator

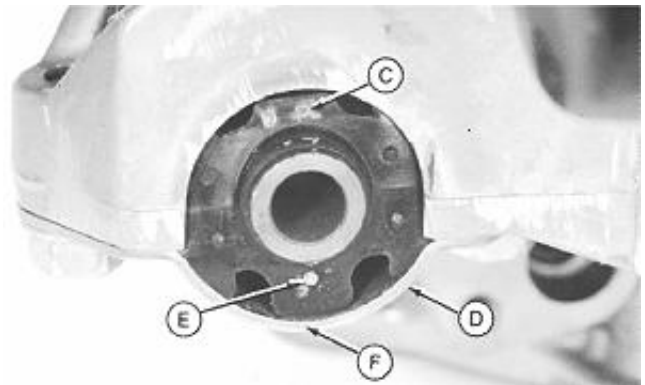

Engine Mount Isolator

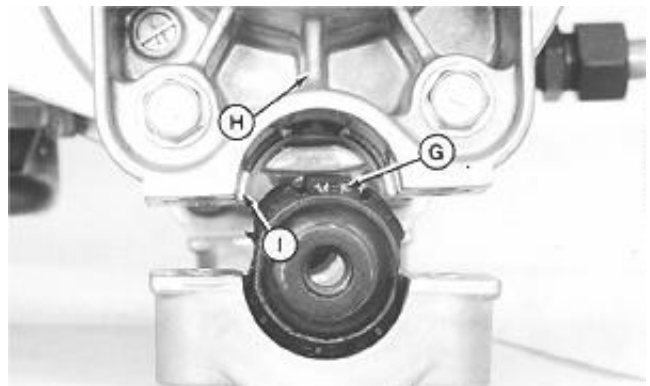

Axle Mount Isolator

MX,2005CL,5 -19-04MAY92

M46170 -UN-22APR92

M46171 -UN-22APR92

M46172 -UN-22APR92

M46172

33920

INSTALL ENGINE

1. Lower engine into frame. Connect cap screws (G).
2. Connect fuel line.
3. Install bracket (H).
4. Install braces (I).
5. Install muffler using cap screws (F). Install muffler shield.
6. Connect linkages (B) and (E).
7. Connect harness (A).
8. Connect wires (C) and (D).

A—Engine Harness
B—Brake Linkage
C—Purple Wire (Solenoid)
D—Red Wires (Battery Cable and Pigtail)
E—Shift Linkage
F—Muffler Cap Screws
G—Engine Mount Cap Screws (3)
H—Fender Bracket
I—Frame Braces (2)

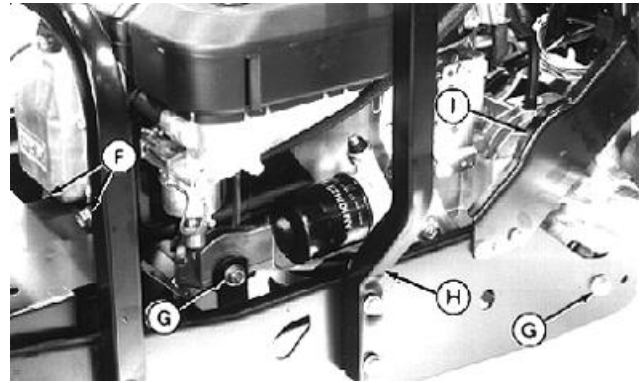
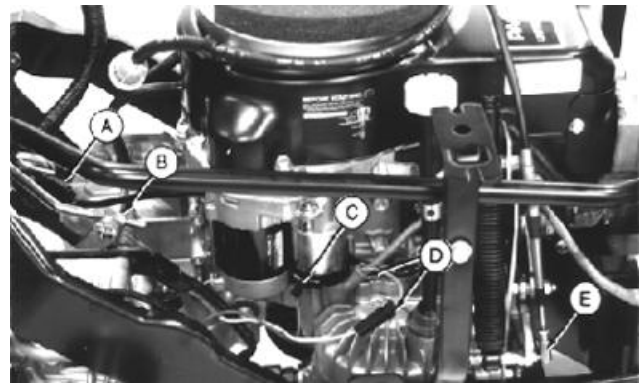

MX,2005CL,A3 -19-23OCT95

9. Install seat platform (B) and fenders. (See Remove and Install Seat Platform in Section 80, Group 15.)

NOTE: Inspect O-rings and nylon bushings before installing mower deck arms. Replace damaged parts. Lubricate O-rings and bushings before installing mower deck arms.

10. Install mower deck arms. Install snap ring (A).

11. Install wheels. (See Remove and Install Wheels in Section 60, Group 10.)

12. Install mower deck.

13. Fill crankcase to correct level with proper oil. (See Engine Oil in Section 10, Group 20.)

14. Connect battery cables.

15. Open fuel shut-off valve (C).

16. Adjust throttle. (See Throttle Cable Adjustment in Section 220, Group 15.)

17. Adjust shift linkage. (See Direction Pedal Travel Adjustment and Direction Pedal Neutral Adjustment in Section 250, Group 15.)

18. Adjust brake pedal travel (See Brake Travel Adjustment in Section 265, Group 20.)



M53037 -UN-13APR89

20
5

ENGINE CONFIGURATION CHART

The PA420A and PA540A engines have an engine configuration number following the engine model number to help separate engine changes. Use the engine configuration number to determine the proper service specifications and procedures to follow in this technical manual.

ENGINE CONFIGURATION CHART

F510 (Engine S.N. -3887)	PA420A-AS00
(Engine S.N. 3888-4898)	PA420A-BS00
(Engine S.N. 4899-7322)	PA420A-AS01
(Engine S.N. 7323-)	PA420A-AS02
F525 (Engine S.N. -7891)	PA540A-AS00
(Engine S.N. 7892-11999)	PA540A-BS00
(Engine S.N. 12000-21944)	PA540A-AS01
(Engine S.N. 21945-)	PA540A-AS02

MX,1015CL,1 -19-23OCT95

SERVICE PARTS KITS

The following kits are available through your parts catalog:

- Blower Housing Engine Cover Kit
- Decal Kit
- Flywheel Screen and Spacer Kit
- Dipstick Tube Kit

MX,2010CL,A0 -19-04MAY92

REMOVE AND INSTALL BLOWER HOUSING

1. Disconnect spark plug cap.
2. Remove air cleaner assembly.
3. Remove fuel pump. (See Remove and Install Fuel Pump in Section 30, Group 10.)
4. Remove cover (A).
5. Remove dipstick tube.
6. Remove protector and screen (D).
7. Remove blower housing (C).
8. Install blower housing, screen and protector.
9. Adjust flywheel screen. (See Flywheel Screen Adjustment in this group.)
10. Install cylinder head cover and dipstick tube.
11. Install fuel pump.
12. Install air cleaner assembly.

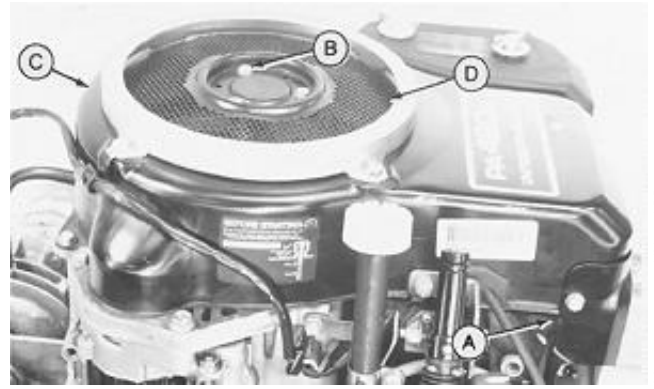

A—Cylinder Head Cover
 B—Flywheel Screen Screws
 C—Blower Housing
 D—Flywheel Screen

MX,2010CL,A2 -19-23OCT95

FLYWHEEL SCREEN ADJUSTMENT

Adjust gap (C) between the blades under screen (A) and blower housing (B) to specifications using spacers from Flywheel Screen and Spacer Kit.

SPECIFICATIONS

Minimum Gap 1.5 mm (0.059 in.)

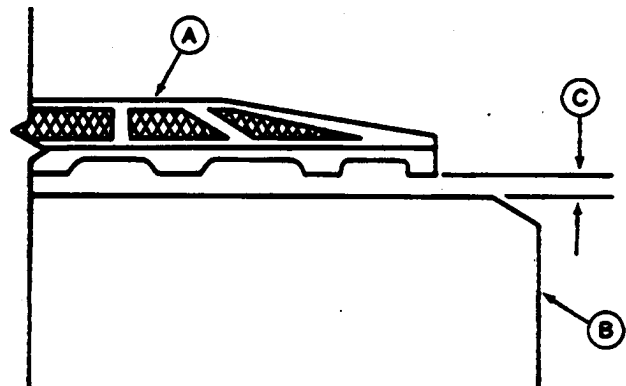

MX,2010CL,A2A -19-23OCT95

20
10
2

M53040 -UN-13APR89

M38037 -UN-29AUG88

REMOVE AND INSTALL FLYWHEEL

1. Remove ignition coil. (See Remove and Install Armature With Coil in Section 40, Group 15.)
2. Hold flywheel and remove nut.
3. Remove bracket (A).
4. Remove flywheel using a flywheel puller.
5. Install flywheel and bracket.
6. Install nut. Tighten nut to specifications.
7. Install and adjust ignition coil.

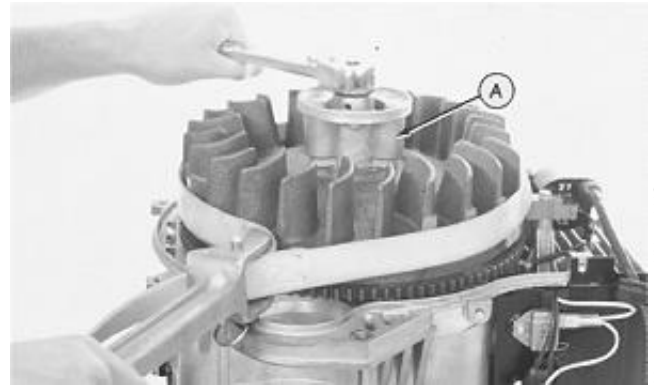

M50051 -UN-31AUG88

20
10
3

FLYWHEEL NUT TORQUE SPECIFICATIONS

PA420A	137 N·m (101 lb-ft)
PA540A	172 N·m (127 lb-ft)

MX,2010CL,A3A -19-23OCT95

ENGINE CONFIGURATION CHART

The PA420A and PA540A engines have an engine configuration number following the engine model number to help separate engine changes. Use the engine configuration number to determine the proper service specifications and procedures to follow in this technical manual.

ENGINE CONFIGURATION CHART

F510 (Engine S.N. -3887)	PA420A-AS00
(Engine S.N. 3888-4898)	PA420A-BS00
(Engine S.N. 4899-7322)	PA420A-AS01
(Engine S.N. 7323-)	PA420A-AS02
F525 (Engine S.N. -7891)	PA540A-AS00
(Engine S.N. 7892-11999)	PA540A-BS00
(Engine S.N. 12000-21944)	PA540A-AS01
(Engine S.N. 21945-)	PA540A-AS02

MX,1015CL,1 -19-23OCT95

ESSENTIAL TOOLS

NOTE: Order tools from the U.S. SERVICEGARD™ Catalog or from the European Microfiche Tool Catalog (MTC). Some tools may be available from a local supplier.

Number	Name	Use
JDG504	Valve Guide Driver	Replace valve guide bushings

MX,2015CL,1 -19-04MAY92

SERVICE EQUIPMENT AND TOOLS

NOTE: Order tools from the U.S. SERVICEGARD™ Catalog or from the European Microfiche Tool Catalog (MTC). Some tools may be available from a local supplier.

Name	Use
JTO7096—Valve Guide Service Kit	Finish ream valve guides
D-20020WI—7 mm Valve Guide Reamer (Included in JTO7096)	Finish ream valve guides
JDM52A—Valve Seat Service Set	Recondition valve seats
NEW 128—30° x 45° Cutter Head (Included in JDM52A)	Recondition valve seats
NEW 100-7.0—7 mm Pilot (Included in JDM52A)	Recondition valve seats

MX,2015CL,1A -19-23OCT95

OTHER MATERIAL

Number	Name	Use
	SCOTCH-BRITE® Abrasive Sheets/Pads	Clean Cylinder Head
	Valve Guide Cleaner	Clean Valve Guides
	Stanisol (or Kerosene)	Finish Ream Valve Guide
	Prussian Blue Compound	Check Valve Seat Contact

SCOTCH-BRITE is a trade mark of the 3M Company.

MX,4015A1,A1 -19-21OCT92

SERVICE PARTS KITS

The following kits are available through your parts catalog:

Rocker Arm and Shaft Kit

Intake Valve Kit

Exhaust Valve Kit

MX,4015A1,A1A -19-21OCT92

REMOVE AND INSTALL ROCKER ARM ASSEMBLY

1. Remove rocker arm cover.
2. Turn crankshaft until piston is at highest position in compression stroke.
3. Remove rocker shaft and arms (A).

IMPORTANT: Mark push rods for reassembly in original locations.

4. Remove push rods (B).

IMPORTANT: Align rocker arms over push rods during assembly.

5. Install push rods and rocker arm assemblies.
6. Check valve clearance. (See Valve Clearance Adjustment in Section 220, Group 15.)

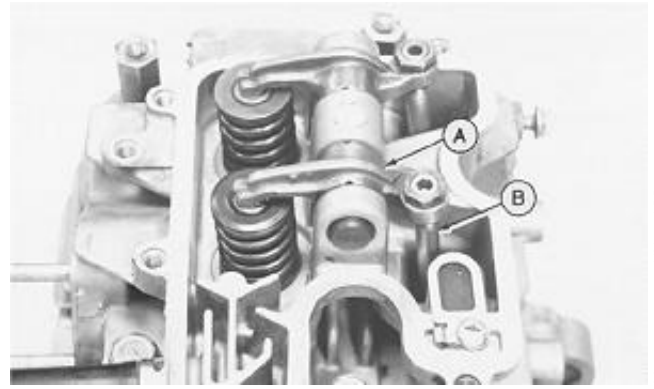

M52967 -UN-05APR89

20
15
3

MX,2015CL,A2 -19-23OCT95

INSPECT ROCKER ARM ASSEMBLY

1. Measure outside diameter of rocker shaft. Replace shaft if O.D. is less than **12.94 mm (0.509 in.)**.
2. Measure inside diameter of rocker arm bearing. Replace rocker arm if I.D. is greater than **13.07 mm (0.515 in.)**.



M50028 -UN-31AUG88



M50029 -UN-31AUG88

MX,2015CL,A3 -19-23OCT95

INSPECT PUSH ROD

Inspect push rod for bend using V-blocks and a dial indicator. Turn rod slowly and read variation on indicator. Replace if variation is greater than **0.30 mm (0.012 in.)**.

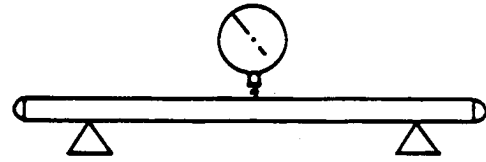

MX,2015CL,A3A -19-23OCT95

M50044
-UN-31AUG88

REMOVE AND INSTALL CYLINDER HEAD ASSEMBLY

1. Remove blower housing. (See Remove and Install Blower Housing in Group 10.)
2. Remove carburetor. (See Remove and Install Carburetor in Section 30, Group 20.)
3. Remove rocker arm assembly. (See Remove and Install Rocker Arm Assembly in this group.)
4. Remove shields.
5. Remove spark plug.
6. Remove cap screws, nuts, spacers (A), and washers (B) to remove cylinder head assembly.
7. Make repairs as necessary. (See procedures in this group.)

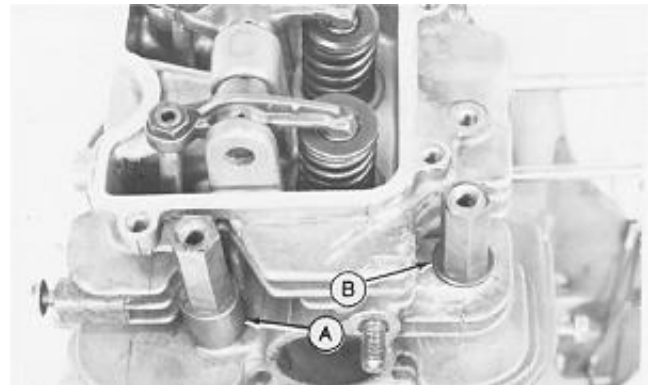

PA420A

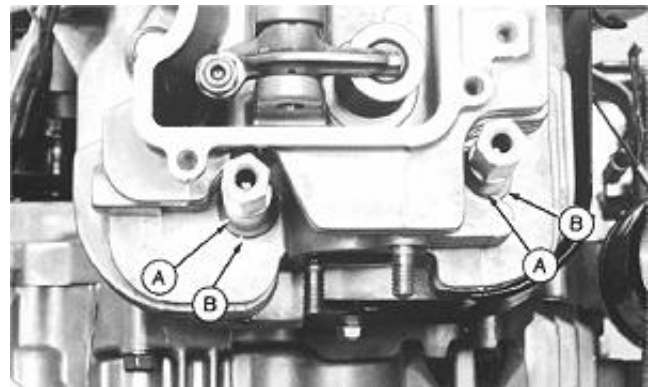

PA540A

MX,2015CL,A4 -19-23OCT95

M52968
-UN-05APR89

M46166
-UN-22APR92

IMPORTANT: Gasket surfaces are coated with sealant. Do not damage surfaces or gasket during installation.

8. Install cylinder head assembly with new gasket. Install cap screws, spacers, washers, and nuts and tighten finger tight.

9. Tighten cap screws and nuts if equipped, in sequence shown. Tighten to initial torque of **32 N·m (24 lb-ft)**.

10. Continue in sequence, **7 N·m (62 lb-in.)** at a time, to final torque of **52 N·m (38 lb-ft)**.

11. Install spark plug and tighten to **20 N·m (177 lb-in.)**.

12. Install shields.

13. Check valve clearance. (See Valve Clearance Adjustment in Section 220, Group 15.)

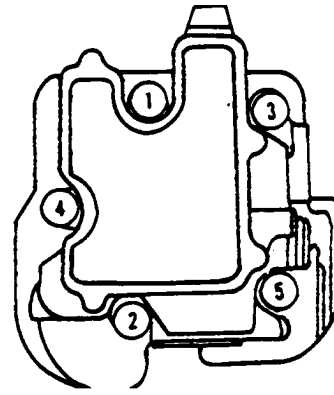

REMOVE AND INSTALL VALVES AND SPRINGS

1. Remove cylinder head. (See Remove and Install Cylinder Head Assembly in this group.)
2. Compress intake valve spring with JDM70 Valve Spring Compressor and remove collet halves (A).
3. Remove spring retainer (B) and spring (C).
4. Remove exhaust valve rotator with a magnet.
5. Support exhaust valve from below and press down on spring retainer.
6. Remove retainer, spring and valves.
7. Inspect and replace stem seals as necessary. (See Inspect and Replace Stem Seals in this group.)
8. Inspect and analyze valves. (See Inspect Valves in this group.)
9. Inspect springs, valves, guides and seats. (See procedures in this group.)
10. Install valves, springs, and retainers.

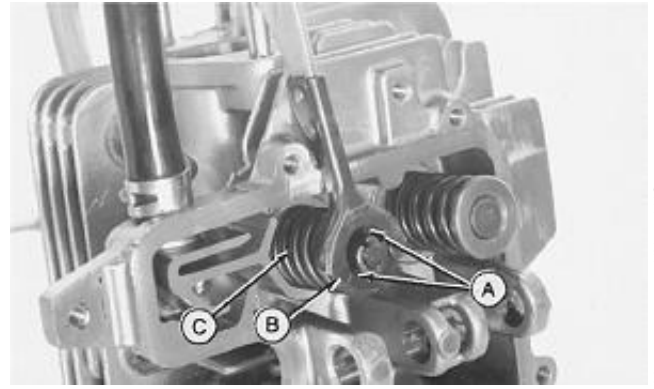

M50033 -UN-31AUG88

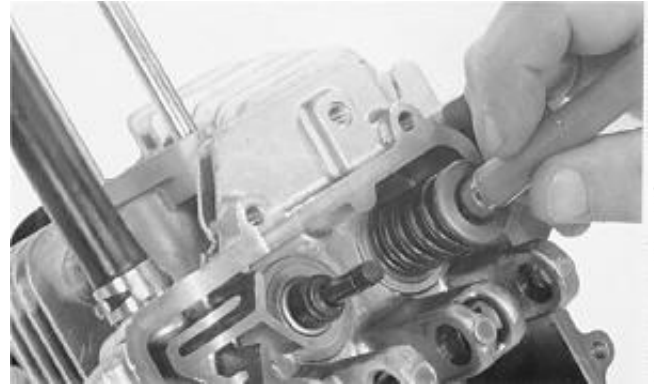

M50034 -UN-31AUG88

MX,2015CL,A6 -19-23OCT95

INSPECT AND REPLACE STEM SEALS

Remove valves and springs. (See Remove and Install Valve and Springs in this group.)

IMPORTANT: Inspect seal. If seal is not damaged, DO NOT remove it. Bottom spring retainer can only be removed with valve stem seal. Removal of retainer or seal damages stem seal. If necessary to replace stem seal, remove with screwdriver.



M50111 -UN-31AUG88

MX,2015CL,A7 -19-23OCT95

INSPECT SPRINGS

Inspect spring free length. Replace if damaged or if less than specifications.

FREE LENGTH SPECIFICATIONS (MINIMUM)

PA420A/PA540A-AS00	37.50 mm (1.476 in.)
PA420A/PA540A-BS00, AS01 and AS02	35.50 mm (1.398 in.)

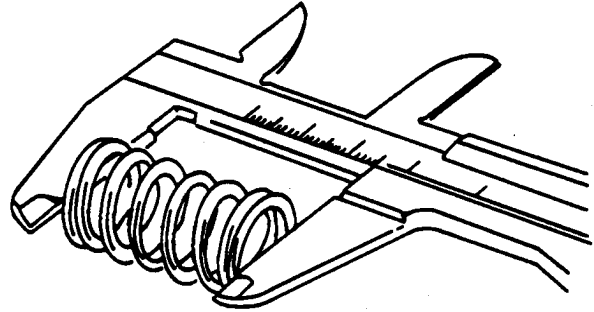

M50036
-JUN-31AUG88

MX,2015CL,A8 -19-23OCT95

INSPECT CYLINDER HEAD

1. Remove carbon deposits from combustion chamber and gasket surface using SCOTCH-BRITE abrasive pads or an equivalent.
2. Clean head with solvent.
3. Inspect for cracks or broken cooling fins.
4. Inspect gasket surface for burrs and nicks.
5. Inspect head gasket for burns and traces of gas leakage. Replace if necessary.
6. Check that oil drainback passages are not plugged.
7. Put cylinder head on a flat surface plate. Check for distortion at several points around the head using a feeler gauge. Replace head if distortion is more than **0.05 mm (0.002 in.)**.



M50032
-JUN-31AUG88

MX,2015CL,A9 -19-23OCT95

REPLACE CYLINDER HEAD STUDS

Inspect studs for cracks or wear.

Install two nuts on stud and tighten together. Remove stud.

Put thread lock and sealer (medium strength) on threads of stud and install in block. Tighten to **36 N·m (27 lb-ft)**.

MX,2010CL,A10 -19-23OCT95

INSPECT VALVES

1. Remove carbon from valve head, face and stem with a power-operated wire brush. Be sure carbon is removed, not merely burnished.
2. Check valve faces, heads and stems for defects.
3. Replace warped valves (A) or valves with less than 0.6 mm (0.02 in.) margin (B). Valve stem ends (C) should be ground square before you check valve-to-tappet clearance.
4. Measure valve stem outside diameter. Replace valve if outside diameter is less than wear limit specifications.

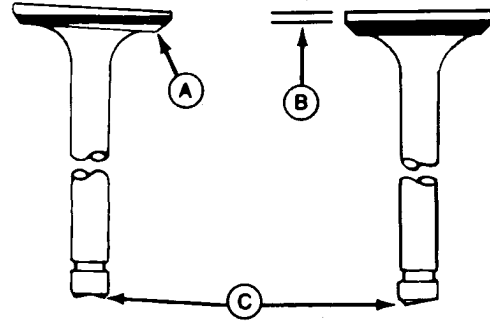

VALVE STEM O.D. SPECIFICATIONS—WEAR LIMIT

Intake valve	6.930 mm (0.2728 in.)
Exhaust valve	6.915 mm (0.2722 in.)

VALVE STEM O.D. SPECIFICATIONS—NEW PARTS

Intake valve (Minimum)	6.972 mm (0.2745 in.)
(Maximum)	6.987 mm (0.2751 in.)
Intake valve to guide clearance (Minimum)	0.013 mm (0.0005 in.)
(Maximum)	0.043 mm (0.0017 in.)
Exhaust valve (Minimum)	6.965 mm (0.2742 in.)
(Maximum)	6.980 mm (0.2748 in.)
Exhaust valve to guide clearance (Minimum)	0.020 mm (0.0008 in.)
(Maximum)	0.050 mm (0.0020 in.)

MX,2015CL,10 -19-23OCT95

5. Inspect valve stem for bend using V-blocks and a dial indicator. Turn valve slowly and read variation on indicator. Replace if variation is greater than **0.03 mm (0.001 in.)**.

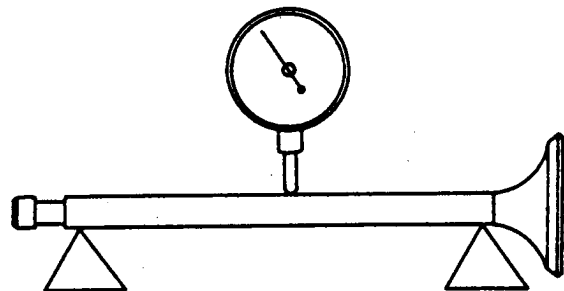

M98,2015A,A18 -19-23OCT95

ANALYZE VALVES

Lead deposits on the intake valve are caused by exhaust gas leakage past the valve. This indicates that the valve is not seating properly.

IMPORTANT: Do not grind the exhaust valve or valve life will be shortened.

Grind intake valve and reface the seat to correct this condition.

NOTE: Be sure to reset valve-to-tappet clearance after grinding valves.



M29934 -UN-06SEP88

20
15
9

MX,10005A1,A2 -19-21OCT92

Valve stem corrosion is caused by moisture in the engine. Moisture in the fuel-air-mixture can condense inside the engine when the engine is stopped and cools down.

Valve corrosion can also occur during storage. Fogging or pouring oil in the combustion chamber before storing helps prevent valve corrosion.

Corroded or pitted valves collect deposits and may cause sticking valves. Replace badly corroded or pitted valves.



M5563 -UN-31AUG88

M21,2415G,37 -19-04MAY92

Exhaust valves are designed to function in temperatures exceeding (2760°C) 5000°F. However, when operating at high temperatures for long periods of time, valve burning may occur. Valves running too hot will show a dark discoloration of the valve stem into the area protected by the valve guide. Another indication is distortion of the valve margin (A) and valve face (B). Valve inserts may also begin to burn away.

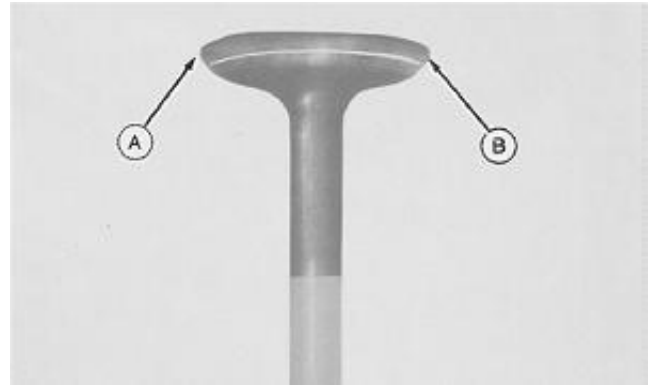

M30024 -UN-06SEP88

IMPORTANT: DO NOT run the engine with blower housing removed.

Poor engine cooling due to dirt or obstructions is a common cause for overheating an engine and the valves. Remove blower housing and clean the engine cooling fins.

Other causes for valves running hot are worn valve guides or valve springs, incorrect valve clearance, lean fuel-air mixture and incorrect or overheated spark plug.

M21,2415G,38 -19-23OCT95

Using old or stale gasoline is a common cause for sticky valves (A).

This gummy deposit can be seen on the valve. When this condition exists, the carburetor may also contain gum deposits and will require a complete cleaning.

Always use fresh gasoline and drain fuel tank, lines, and carburetor before storing tractor.



M29936 -UN-06SEP88

M21,2415G,39 -19-04MAY92

INSPECT VALVE GUIDES

1. Clean inside of valve guides with valve guide cleaner.
2. Measure inside diameter of valve guides or bushings. Replace bushing if inside diameter is greater than specifications. (See Replace Valve Guide Bushings in this group.)

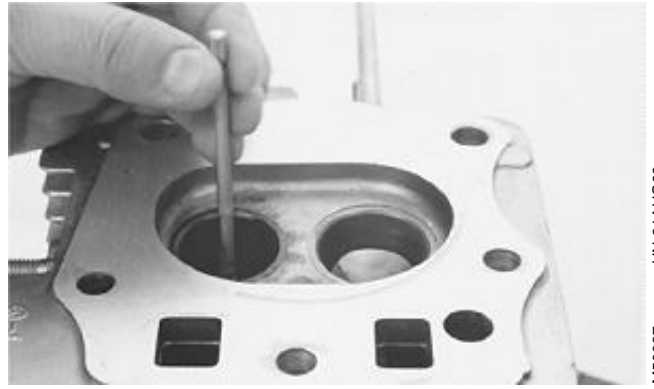

M50037 -UN-31AUG88

201511

VALVE GUIDE I.D. SPECIFICATIONS

Item	New Parts	Wear Limit
Intake and Exhaust	7.000-7.015 mm (0.2756-0.2762 in.)	7.07 mm (0.278 in.)
Intake valve to guide clearance	0.013-0.043 mm (0.0005-0.0017 in.)	
Exhaust valve to guide clearance	0.020-0.050 mm (0.0008-0.0020 in.)	

MX,2015CL,11 -19-23OCT95

REPLACE VALVE GUIDE BUSHINGS

1. Drive valve guide bushing (A) into valve chamber (B) using JDG-504 Valve Guide Driver.

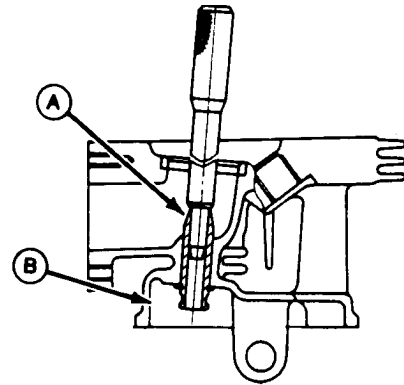

M50038 -UN-06APR91

MX,2015CL,12 -19-04MAY92

2. Clean carbon deposits from valve guide port.
3. Install new bushing with valve guide driver.
4. For PA420A/PA540A-AS00, install bushing from valve chamber side until snap ring (A) just seats on head.

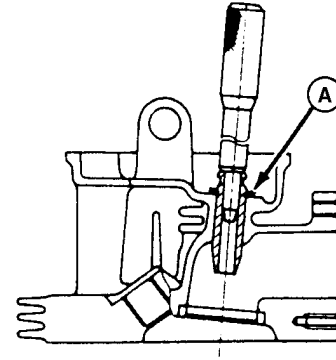

PA420A/PA540A-AS00

For PA420A/PA540A-BS00, AS01 and AS02, install bushing from valve chamber side until top of bushing (B) is specified distance above machined surface of cylinder head.

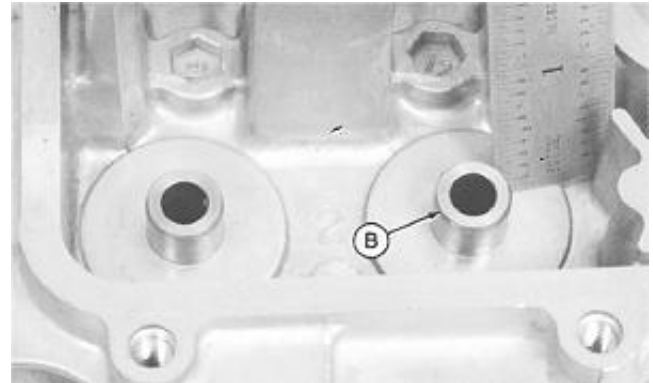

PA420A/PA540A-BS00, AS01 and AS02

MX,2015CL,13 -19-23OCT95

VALVE GUIDE BUSHING HEIGHT SPECIFICATIONS

PA420A	12 mm (0.472 in.)
PA540A	9.5 mm (0.372 in.)

20
15
12

M81637 -UN-19JUN95

M46167 -UN-22APR92

5. Finish reaming valve guide bushings with stanisol or kerosene lubricant and D-20020WI—7 mm Valve Guide Reamer from JT07096 Valve Guide Service Kit. Turn reamer clockwise.
6. Thoroughly clean valve area before assembly.

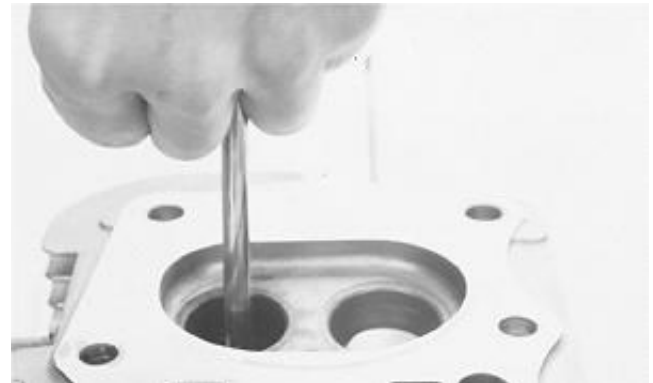

BUSHING FINISHED I.D. SPECIFICATION

Valve Guide	7—7.02 mm (0.275—0.276 in.)
-------------	-------	-----------------------------

MX,2015CL,14 -19-23OCT95

M50040 -UN-31AUG88

RECONDITION VALVE SEATS

1. Inspect valve seats for damage. If seats are loose, warped or distorted beyond reconditioning, replace cylinder head. Pitted or worn seats can be refaced using NEW 128—30° x 45° Cutter Head and NEW 100-7.0—7 mm Pilot from JDM52A Valve Seat Service Set.

2. To recondition valve seat, cut at 45° angle (B) to clean up seat. Cut narrowing angle (E) at 30°. Finish cut at 45° (B) to establish seating surface width (A).

3. Cut valve seating surface (A) as close as possible to specifications.

4. Lap valves to seats after refacing. (See Lap Valves in this group.)

SPECIFICATIONS

A—Valve Seating Surface	1.10—1.46 mm (0.043—0.057 in.)
B—Valve Seat Angle	45°
C—Valve Face Angle	45°
D—Valve Margin	0.60 mm (0.020 in.)
E—Valve Narrowing Angle	30°

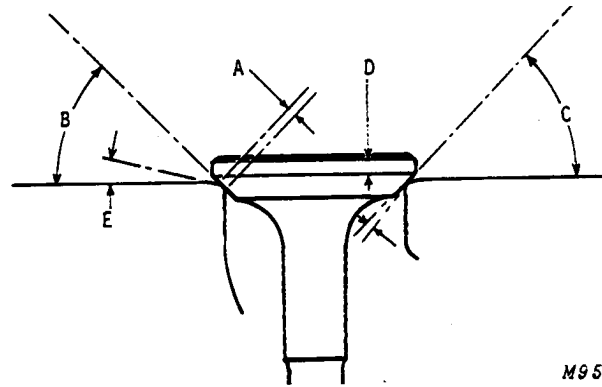
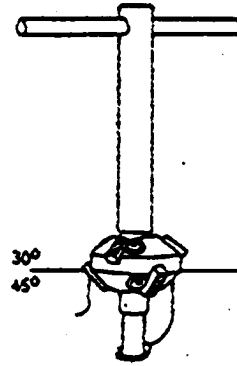

M955

MX,2015CL,15A -19-23OCT95

5. Center valve seat on the valve face:

- (A) correct position.
- (B) incorrect positions.

6. Check seat for good contact using Prussion Blue Compound.

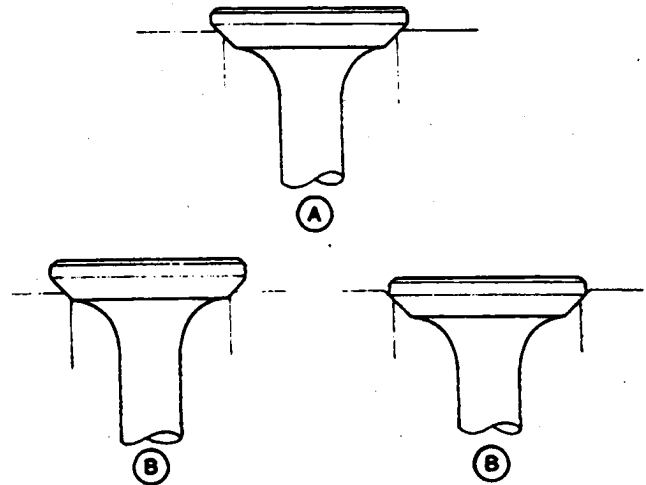

M18615 -JUN-07SEP88

MX,2015CL,16 -19-23OCT95

LAP VALVES

1. If seat does not make proper contact, lap the valve into the seat.
2. Apply small amount of fine lapping compound to face of valve.
3. Grip top of valve with a vacuum cup tool. Turn valve to lap valve to seat.
4. Lift valve from seat every 8 to 10 strokes. Lap until a uniform ring appears around the surface of the valve face.
5. Wash all parts in solvent to remove lapping compound. Dry parts.
6. Check position of lap mark on valve face. Lap mark must be on or near center of valve face.



M50041
-UN-31AUG88

MX,10005A1,A3 -19-04MAY92

CHECK VALVE CLEARANCE

NOTE: Valve repair changes valve clearance. Only check and adjust valve clearance when engine is cold.

1. Turn crankshaft until piston is at highest position in compression stroke, top dead center (TDC).
2. Measure clearance.



M50048
-UN-31AUG88

MX,2015CL,17 -19-23OCT95

3. If necessary, adjust clearance to **0.15 mm (0.006 in.)**.



M50049
-UN-31AUG88

MX,2015CL,18 -19-23OCT95

ENGINE CONFIGURATION CHART

The PA420A and PA540A engines have an engine configuration number following the engine model number to help separate engine changes. Use the engine configuration number to determine the proper service specifications and procedures to follow in this technical manual.

ENGINE CONFIGURATION CHART

F510 (Engine S.N. -3887)	PA420A-AS00
(Engine S.N. 3888-4898)	PA420A-BS00
(Engine S.N. 4899-7322)	PA420A-AS01
(Engine S.N. 7323-)	PA420A-AS02
F525 (Engine S.N. -7891)	PA540A-AS00
(Engine S.N. 7892-11999)	PA540A-BS00
(Engine S.N. 12000-21944)	PA540A-AS01
(Engine S.N. 21945-)	PA540A-AS02

MX,1015CL,1 -19-23OCT95

OTHER MATERIAL

Number	Name	Use
	Zinc Oxide/Wood Alcohol	Check block for cracks.

MX,4020A1,A1A -19-23OCT95

20
20
1

SERVICE PARTS KITS

The following kits are available through your parts catalogue.

Camshaft and Tappet Kit

20
20
2 Camshaft Axial Play Shim Kit

2 Piston Ring Kit

Oversized Piston

Oversized Piston Rings

Undersized Connecting Rod

Crankshaft End Play Shim Kit

Cylinder Block

Overhaul Gasket Kit

Short Block Kit

Oil Pump Kit

Governor and Shaft Kit

MX,2020CL,A2 -19-04MAY92

REMOVE AND INSTALL CRANKCASE COVER

CRANKCASE OIL CAPACITY

Item	PA420A	PA540A
Without Filter	2.4 L (2.5 qt)	2.6 L (2.7 qt)
With Filter	2.6 L (2.7 qt)	2.8 L (2.9 qt)
Total System	3.4 L (3.5 qt)	3.9 L (4.1 qt)

1. Remove drain plug (G) and drain crankcase.
2. Disconnect hose (A).
3. Remove dipstick tube (B), cam (C) and bracket (D).
4. For PA540A, remove oil lines (H), hydrostatic pump cover (E), housing (F), rotating cylinder, and swash plate. Remove two crankcase cover cap screws with washers (I) from inside hydrostatic pump.

For PA420A, remove starter to provide clearance for removing mounting cap screw. Remove two crankcase cover cap screws (2 and 9) from top of crankcase.

5. Remove remaining cap screws from bottom side of crankcase cover. Carefully remove crankcase cover and gasket.

6. Clean crankcase, hydrostatic pump, and crankcase cover gasket surfaces.

NOTE: DO NOT force cover. Gears must mesh for proper positioning.

7. Install gaskets and covers. Tighten cap screws using the sequence shown to specification.

TORQUE SPECIFICATIONS

Crankcase cover	
PA420A/PA540A-AS00, BS00 and AS01	23 N·m (204 lb-in.)
PA420A/PA540A-AS02	29 N·m (257 lb-in.)
Hydrostatic pump cover long bolts	25 N·m (226 lb-in.)
Hydrostatic pump cover short bolt	20 N·m (177 lb-in.)
Oil Drain Plug	24 N·m (217 lb-in.)

- A—Vent Hose
- B—Dipstick Tube
- C—Linkage Bracket
- D—Directional Cam
- E—Hydrostatic Pump Cover
- F—Housing
- G—Drain Plug
- H—Oil Lines
- I—Crankcase Cover Cap Screws (2)

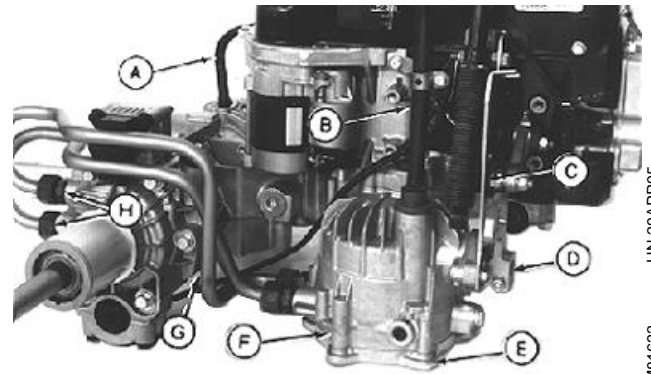

PA540A

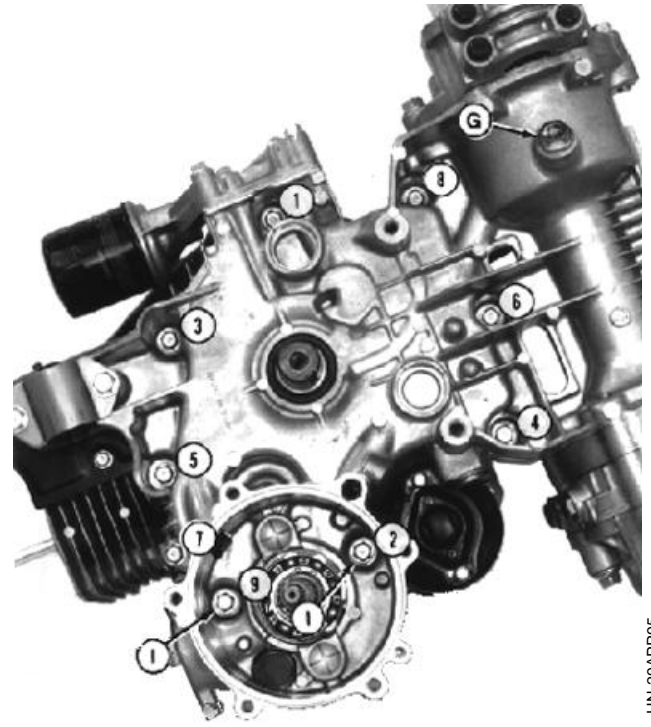

PA540A

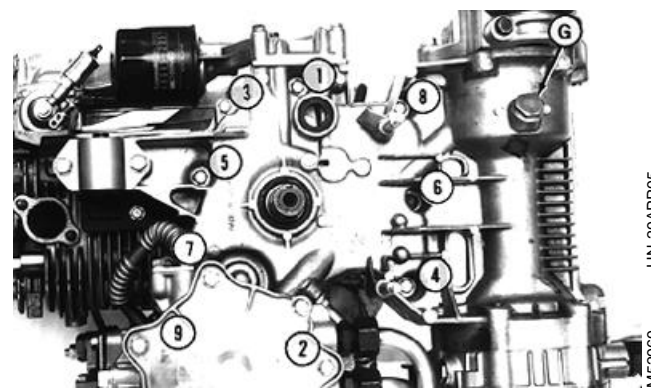

PA420A

REMOVE AND INSTALL CRANKCASE COVER MAGNET

1. Remove cap screws (A).
2. Remove magnet (B) from holder.

IMPORTANT: Large amounts of metal particles attached to magnet may indicate serious engine wear. Repair or replace severely worn parts to avoid engine damage.

3. Clean magnet. Replace if cracked.
4. Install magnet assembly. Tighten cap screws to **6 N-m (53 lb-in.)**.

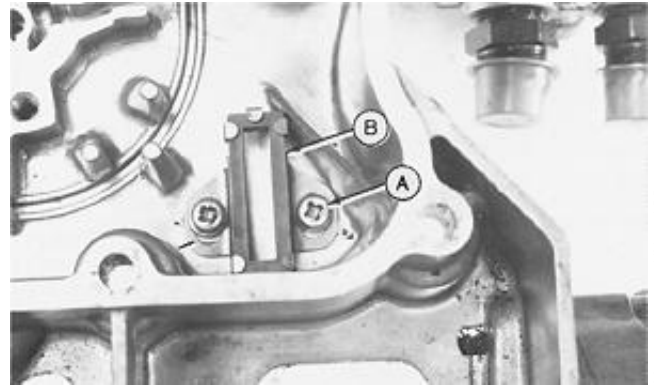

M53027 -UN-05APR89

MX,2020CL,A1A -19-23OCT95

REMOVE AND INSTALL CAMSHAFT

1. Remove crankcase cover. (See Remove and Install Crankcase Cover in this group.)

IMPORTANT: Align timing marks to prevent damage to tappets when removing camshaft.

2. Remove crankshaft shim, if equipped, covering timing mark.
3. Rotate crankshaft until timing marks (A) align.
4. Remove camshaft (B).
5. Inspect camshaft. (See Inspect Camshaft in this group.)
6. Apply clean engine oil to camshaft lobes and journals.
7. Align timing marks and install camshaft.
8. Install crankcase cover. (See Remove and Install Crankcase Cover in this group.)



M46182 -UN-27APR92

MX,2020CL,A4 -19-23OCT95

INSPECT CAMSHAFT

Inspect camshaft for worn or broken teeth.

NOTE: Camshaft and tappets are a matched set.
Replace both camshaft and tappets if necessary.

Measure PTO side journal (A), flywheel side journal (B), and lobes (C). Replace camshaft and tappets if less than specifications.

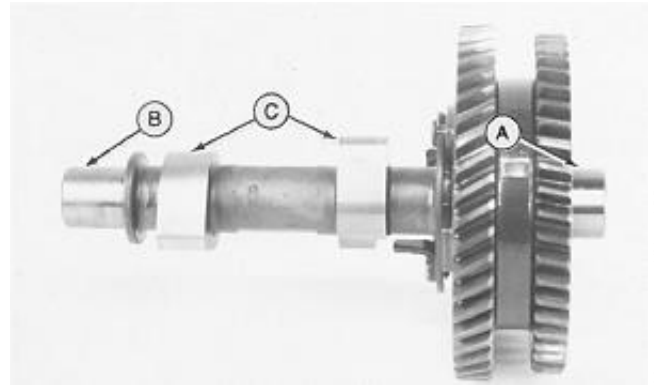

M52971 -UN-05APR89

SPECIFICATIONS (MINIMUM)

	PTO Side Journal	Flywheel Side Journal	Cam Lobes
PA420A	20.91 mm (0.823 in.)	19.91 mm (0.784 in.)	36.75 mm (1.447 in.)
PA540A	20.91 mm (0.823 in.)	20.91 mm (0.823 in.)	37.10 mm (1.461 in.)

MX,2020CL,A5 -19-23OCT95

INSPECT CAMSHAFT BEARINGS

1. Remove camshaft. (See Remove and Install Camshaft in this group.)

2. Measure camshaft bearing bore in cylinder block. Replace block if diameter is greater than specification.

CAMSHAFT BEARING I.D. SPECIFICATIONS (MAXIMUM)

PA420A 20.08 mm (0.790 in.)

PA540A 21.08 mm (0.830 in.)

3. Thoroughly clean ball bearing (C) in crankcase cover with solvent. Coat bearing with light weight oil.

4. Spin bearing by hand and check for axial (A) and radial (B) free play.

5. Replace bearing if it has excessive free play or is noisy.

6. Install camshaft. (See Remove and Install Camshaft in this group.)

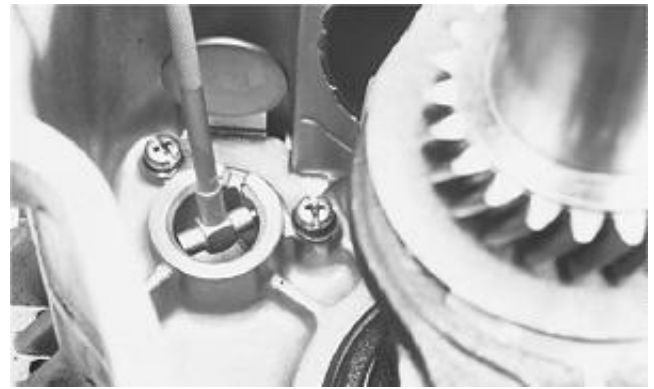

Cylinder Block

M52972 -UN-05APR89

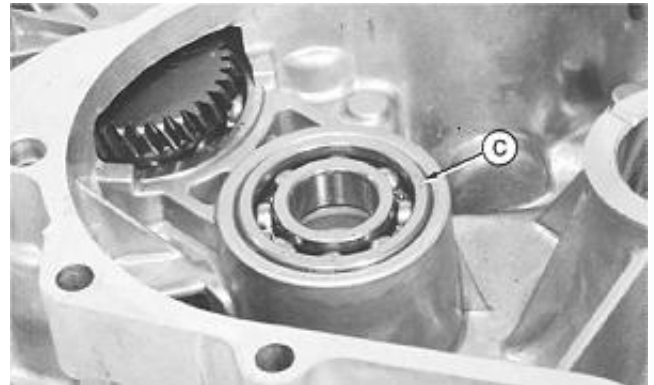

Crankcase Cover

M46174 -UN-22APR92

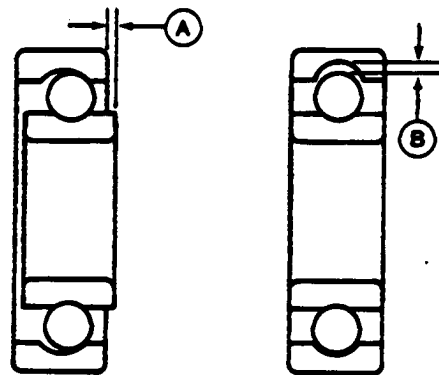

M38073 -UN-29AUG88

MX,2020CL,A6 -19-23OCT95

20
20
6

INSPECT AUTOMATIC COMPRESSION RELEASE (ACR)

1. Remove camshaft. (See Remove and Install Camshaft in this group.)
2. Inspect automatic compression release (ACR) for damage.
3. Inspect spring (A). Replace if worn or damaged.
4. Move weight(s) (B) by hand to check for proper operation. If tab is bent or weights do not move freely, replace camshaft.
5. Check that tab (C) sits slightly above cam lobe when weights are released. Tab should drop below cam when weights are operated.

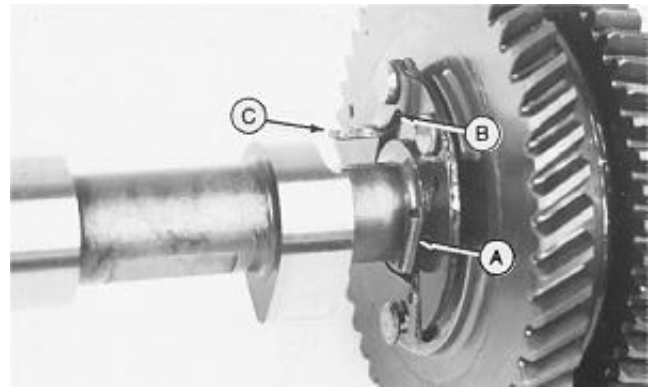

M52974 -UN-05APR89

MX,2020CL,A7 -19-23OCT95

REMOVE, INSPECT AND INSTALL TAPPETS

1. Remove camshaft. (See Remove and Install Camshaft in this group.)

NOTE: Mark tappets so they can be installed in their original bores during assembly.

2. Remove tappets (A).

NOTE: Camshaft and tappets are a matched set. Replace both camshaft and tappets if necessary.

3. Inspect tappets for wear or damage. Replace if necessary.
4. Apply clean engine oil to tappets and bores.
5. Install tappets in original bores.
6. Install camshaft. (See Remove and Install Camshaft in this group.)

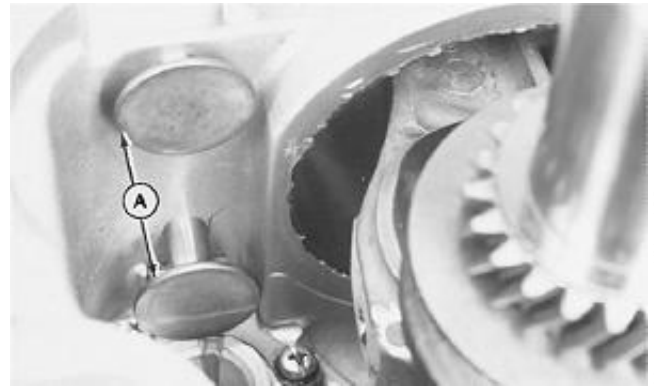

M52973 -UN-05APR89

MX,2020CL,A9 -19-23OCT95

REMOVE AND INSTALL RECIPROCATING BALANCER

1. Remove flywheel. (See Group 10—Remove and Install Flywheel.)
2. Remove camshaft. (See Remove and Install Camshaft in this group.)
3. Remove piston. (See Remove and Install Piston and Connecting Rod in this group.)
4. Remove support shaft (A).
5. Remove crankshaft with balancer assembly (B).
6. Make repairs as necessary. (See procedures in this group.)

NOTE: DO NOT remove oil seal (C) unless it is to be replaced. Removal will damage seal.

7. Inspect oil seals. (See Inspect Oil Seals in this group.)
8. Cover keyway on flywheel end of crankshaft with tape to prevent damage to seal (C) when installing assembly.
9. Put light film of oil on crankshaft bearing surfaces.
10. Install balancer assembly with crankshaft into crankcase (D).
11. Align balancer weight in crankcase and install support shaft. Tighten support shaft nuts to **7.3 N·m (65 lb-in.)**.
12. Adjust crankshaft end play. (See Adjust Crankshaft End Play in this group.)

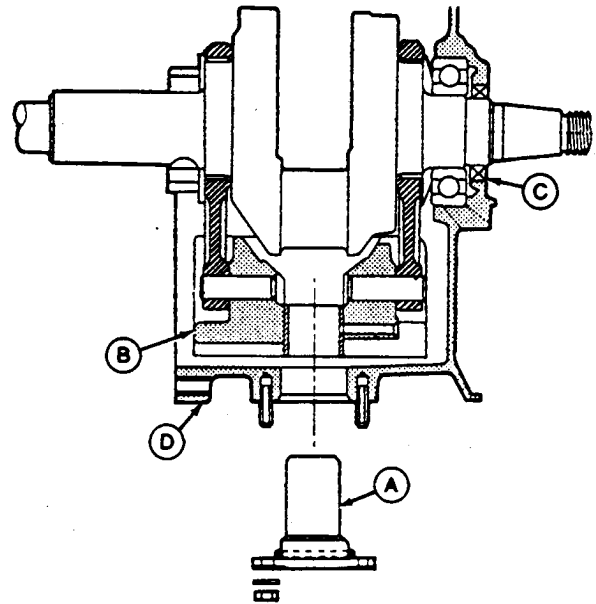

A—Support Shaft
 B—Balancer Assembly
 C—Seal (Replace if removed)
 D—Crankcase

MX,2020CL,A11 -19-23OCT95

20
20
8

-JUN-07SEP88

M51758

DISASSEMBLE AND ASSEMBLE RECIPROCATING BALANCER

1. Remove collar (A), gear (G), key (F), and spacer (H).
2. Remove rods (B) and crankshaft (I).
3. Inspect crankshaft. (See Remove, Inspect and Install Crankshaft in this group.)
4. Inspect balancer assembly. (See Inspect Balancer Assembly in this group.)
5. Put a light film of oil on bearing surfaces.

NOTE: Oil grooves of link rods (B) must face away from crankwebs.

6. Install balance weight to crankshaft with balancer bushing oil passage (E), facing flywheel side (upward).
7. Install collar (A).
8. Install spacer (H) with chamfered I.D. face toward link rod.
9. Install key and crank gear.

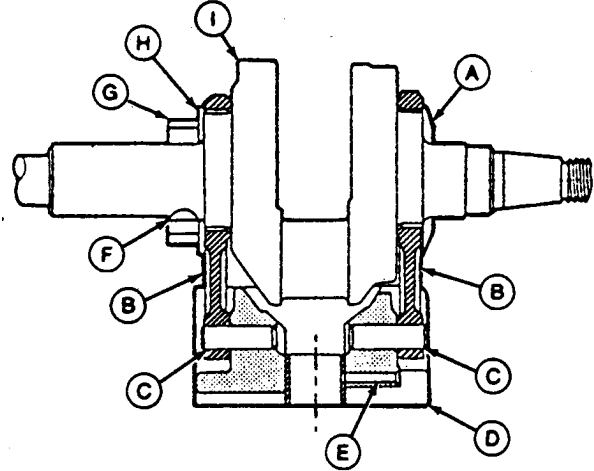

- A—Collar
- B—Link Rod
- C—Wrist Pin
- D—Balance Weight
- E—Oil Passage
- F—Woodruff Key
- G—Crank Gear
- H—Spacer
- I—Crankshaft

MX,2020CL,A12 -19-23OCT95

20
20
9

-JUN-07SEP88

M51759

INSPECT BALANCER ASSEMBLY

1. Clean and inspect all parts for wear or damage. Replace parts, if necessary.
2. Measure crankshaft link rod journals (A). Replace crankshaft if diameter is less than specifications.
3. Measure inside diameter of bearings (B). Replace link rod if small end is greater than specifications. Replace bushing if large end is greater than specifications. (See Replace Balancer Bushing in this group.)
4. Measure inside diameter of support shaft bearing (C). If bearing is greater than specifications, replace bushing. (See Replace Balancer Bushing in this group.)
5. Measure support shaft diameter (D). Replace shaft if diameter is less than specification.
6. Inspect wrist pins (E) for any damage. If necessary, replace weight.

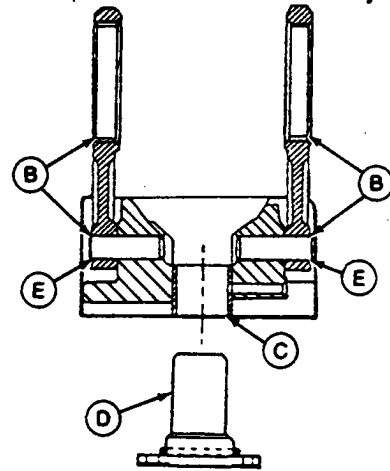
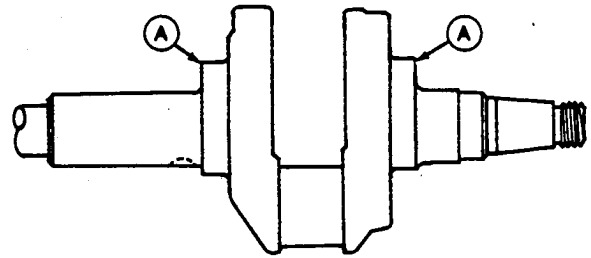

DIAMETER SPECIFICATIONS

Crankshaft Link Rod Journal O.D. (Minimum) (A)	
PA420A	53.95 mm (2.124 in.)
PA540A	57.94 mm (2.281 in.)
Link Rod Small End I.D. (Maximum)	
All	12.06 mm (0.475 in.)
Link Rod Large End I.D. (Maximum)	
PA420A	54.12 mm (2.131 in.)
PA540A	58.15 mm (2.289 in.)
Support Shaft O.D. (Minimum)	
All	25.93 mm (1.021 in.)
Support Shaft Bearing I.D. (Maximum)	
All	26.10 mm (1.027 in.)

- A—Link Rod Journals
- B—Link Rod Bearings
- C—Shaft Bearing
- D—Support Shaft
- E—Wrist Pins

MX,2020CL,A13 -19-23OCT95

M51760 -JUN-07SEP88

**REPLACE BALANCER
BUSHINGS-PA420A/PA540A-AS00, BS00,
AS01 AND AS02**

NOTE: Remove bushings with a bearing driver or a press.

Remove link rod bushings with oil groove side facing up.

1. Remove bushings.
2. Install link rod bushings with seam (A) at a 90° angle to centerline (C).

NOTE: Install bushing from opposite side of oil grooves (B).

3. Install bushing below surface to a depth of **1.00 mm (0.040 in.) (D)**.

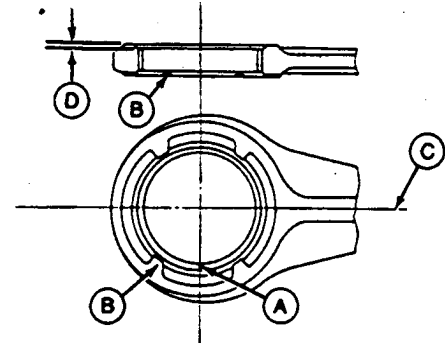

A—Bushing Seam
B—Oil Grooves
C—Link Rod Centerline
D—Measurement

MX,2020CL,A14 -19-23OCT95

4. Align oil passage (A) in bushing and oil passage (B) in weight. Install bushing.

5. Install bushing below surface to a depth of **0.50 mm (0.020 in.) (C)**.

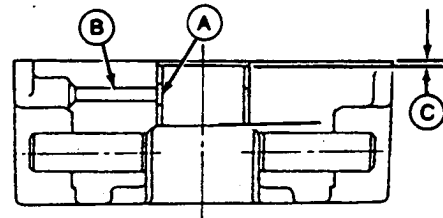

MX,2020CL,14B -19-23OCT95

M51681 -UN-31AUG88

20
20
11

M51725 -UN-07SEP88

REMOVE AND INSTALL PISTON AND CONNECTING ROD

1. Remove cylinder head. (See Remove and Install Cylinder Head Assembly in Group 15.)
2. Remove crankcase cover. (See Remove and Install Crankcase Cover in this group.)
3. Remove carbon and varnish from top of cylinder bore with a ridge reamer.
4. Remove cap screws and connecting rod cap (A).
5. Push piston and connecting rod from cylinder bore.
6. Make repairs as necessary.

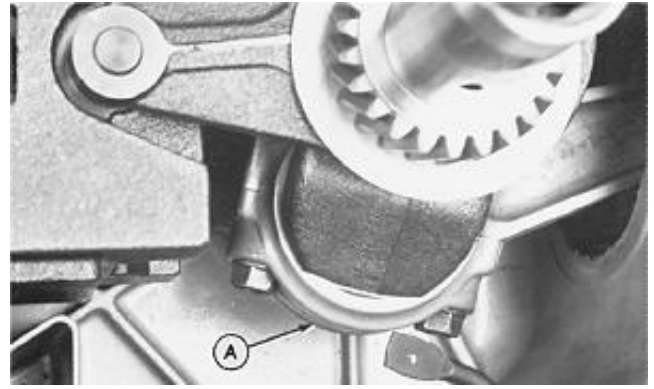

M52984
-UN-05APR89

MX,2020CL,A15 -19-23OCT95

7. Deglaze cylinder bore. (See Deglaze Cylinder Bore in this group.)
8. Stagger piston ring end gaps 180° apart, but do not align with oil ring side rail end gaps.
9. Apply a light film of oil to piston and rings. Compress rings with a ring compressor.
10. Apply a light film of oil to cylinder bore, connecting rod bearing surface and cap screws.
11. Install piston assembly in cylinder bore with engraved match mark/arrow on piston head facing flywheel side of engine.
12. Install connecting rod cap and cap screws. Tighten cap screws to **20 N·m (177 lb-in.)**.



M50074
-UN-31AUG88

MX,2020CL,A16 -19-23OCT95

DISASSEMBLE, INSPECT AND ASSEMBLE PISTON AND CONNECTING ROD

1. Remove circlip, piston pin (A) and connecting rod (B).
2. Inspect all parts for wear or damage. Replace as necessary. (See procedures in this group.)
3. Apply a light film of oil to piston pin and connecting rod bearing.



MX,2020CL,A17 -19-04MAY92

M50063 -UN-31AUG88

20
20
13

4. Align arrow match mark (A) on piston head with MADE IN JAPAN (B) on connecting rod, or if piston is marked with R and L align the R on the piston with the Japanese characters on the connecting rod.
5. Install piston pin and circlip.

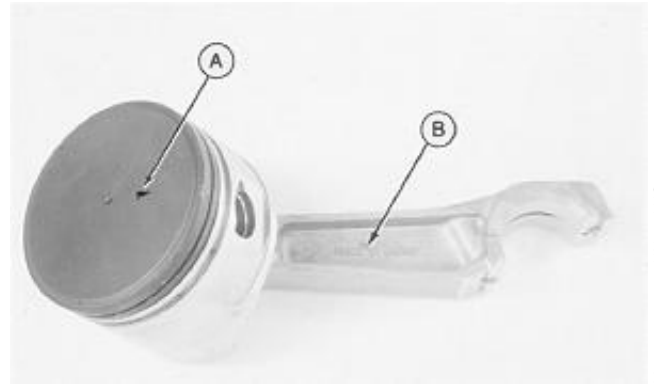

MX,2020CL,A18 -19-04MAY92

M38111 -UN-29AUG88

REMOVE AND INSTALL PISTON RINGS

1. Remove piston rings with a piston ring expander.
2. Inspect piston. Clean piston ring grooves. (See Inspect Piston in this group.)
3. Check piston ring end gap. (See Check Piston Ring End Gap in this group.)
4. Install top ring (A) and second ring (B) with R or NPR mark facing up. Rings should turn freely in grooves.
5. Oil ring is an assembly. Install spacer (C), then side rails (D). Put side rail end gaps 180° apart.

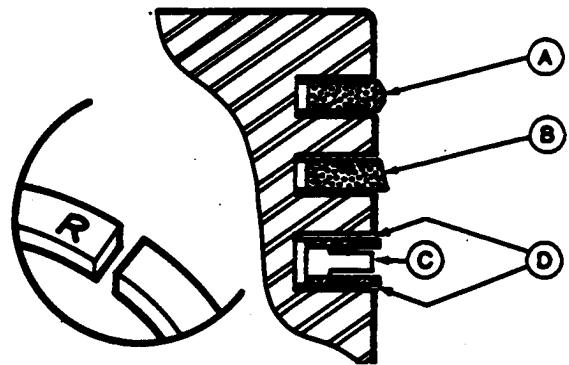

A—Top Ring
B—Second Ring
C—Spacer
D—Side Rails

MX,2020CL,A23 -19-23OCT95

M38074 -UN-29AUG88

CHECK PISTON RING END GAP

1. Before installing rings on piston, check end gap in cylinder bore.
2. Install each ring squarely in bore approximately 25.4 mm (1.0 in.) down from top of cylinder.
3. Check end gap. Replace ring if end gap is more than specifications.

END GAP SPECIFICATIONS

Minimum End Gap	0.18 mm (0.007 in.)
Maximum End Gap	
Compression Rings	
PA420A/PA540A-AS00/BS00/	
AS01/AS02	0.90 mm (0.035 in.)
Oil Ring Side Rails	
PA420A, PA540A	1.30 mm (0.051 in.)



M50073 -UN-31AUG88

MX,2020CL,A24 -19-23OCT95

INSPECT PISTON

1. Analyze piston and piston ring wear. (See Analyze Piston Ring Wear in this group.)
2. Remove piston rings. (See Remove and Install Piston Rings in this group.)

IMPORTANT: DO NOT use a caustic cleaning solution or a wire brush to clean piston.

3. Remove all deposits from the piston.
4. Clean carbon from piston ring grooves with a ring groove cleaner (A). If cleaning tool is not available, break an old ring and use it carefully to clean groove.
5. Check that oil return passages in grooves are open.

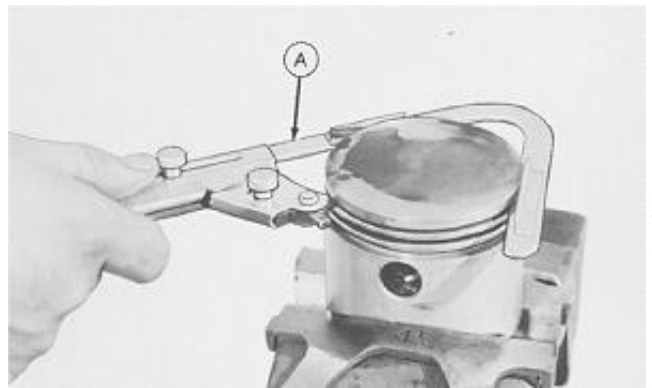

M29946 -UN-06SEP88

MX,2020CL,A19 -19-23OCT95

6. Inspect piston for scoring or fractures. Replace piston if damaged.

NOTE: Inspect clearance visually. Replace piston if clearance appears excessive.

7. Check ring grooves for wear at several points around piston. Replace piston if clearance is greater than specification.



M38102 -UN-29AUG88

20
20
15

CLEARANCE SPECIFICATION (MAXIMUM)

	Top Ring	Second Ring	Oil Control Ring
PA420A,	0.17 mm	0.15 mm	0.20 mm
PA540A	(0.007 in.)	(0.006 in.)	(0.008 in.)

MX,2020CL,A20 -19-23OCT95

8. Measure piston pin outer diameter. Replace if less than specification.

9. Measure piston pin bore. Replace piston if measurement is greater than specification.

SPECIFICATIONS

	Piston Pin O.D. (Minimum)	Piston Bore I.D. (Maximum)
PA420A-AS00/BS00/ AS01/AS02	21.98 mm (0.865 in.)	22.04 mm (0.868 in.)
PA540A-AS00/BS00/ AS01/AS02		



M50064 -UN-31AUG88

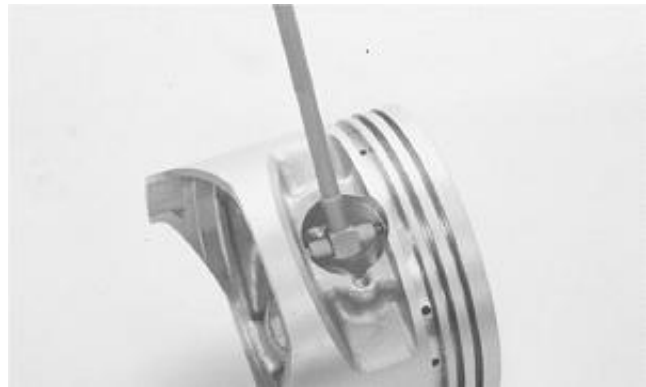

M50065 -UN-31AUG88

MX,2020CL,A21 -19-23OCT95

10. Measure piston O.D. (A) perpendicular to piston pin bore.

11. Measure cylinder bore. (See Inspect Cylinder Block in this group.)

12. Subtract piston O.D. measurement (A) from cylinder bore measurement to determine piston-to-cylinder bore clearance.

13. Replace piston and/or rebore cylinder block if not within specifications. (See Rebore Cylinder Block in this group.)

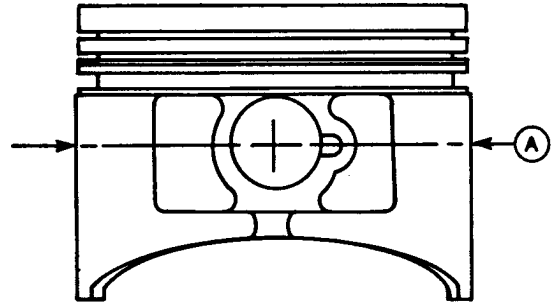

M80398 -UN-06APR91

SPECIFICATIONS

Piston O.D. (A)

PA420A	88.83—88.85 mm (3.4885—3.498 in.)
PA540A	88.83—88.864 mm (3.4885—3.4984 in.)

Piston-to-Cylinder Bore Clearance

PA540A	0.110—0.151 mm (0.0043—0.0059 in.)
PA420A	0.13—0.17 mm (0.005—0.0067 in.)

MX.2020CL,A21A -19-23OCT95

ANALYZE PISTON RING WEAR

Rings of the wrong size or rings having improper end gap will not conform to the shape of the cylinder. This results in high oil consumption and excessive blow-by.

Ring end gaps should be staggered on the piston during installation. End gaps in alignment can also cause oil consumption and blow-by.

Light scuffing or scoring (A) of both rings and piston occurs when unusually high friction and combustion temperatures approach the melting point of the piston material.

When this condition exists, it is due to one or more of the following probable causes:

- Dirty cooling shroud and cylinder head.
- Lack of cylinder lubrication.
- Improper combustion.
- Wrong bearing or piston clearance.
- Too much oil in crankcase causing fluid friction.



M29943 -UN-06SEP88

MX.10010A1,A1A -19-23OCT95

The engine operating at abnormally high temperatures may cause varnish, lacquer or carbon deposits (A) to form in the piston grooves making the rings stick. When this happens, excessive oil consumption and blow-by will occur.

Engine overheating and ring sticking is usually caused by one or more of the following:

- Overloading engine.
- Incorrect ignition timing.
- Lean fuel mixture.
- Dirty cooling fins.
- Incorrect oil.
- Low oil supply.
- Stale fuel.



M29944 -UN-06SEP88

20
20
17

MX,2110BV,49 -19-01OCT92

Vertical scratches (A) across the piston rings are due to an abrasive in the engine. Abrasives may be airborne, may have been left in the engine during overhaul or may be loose lead and carbon deposits.

When this condition exists, check for one or more of the following:

- Damaged, collapsed or improperly installed air filter.
- Loose connection or damaged gasket between air cleaner and carburetor.
- Air leak around carburetor-to-cylinder block gasket.
- Air leakage around throttle shaft.
- Failure to properly clean cylinder bore after reconditioning engine.



M29945 -UN-06SEP88

MX,2110BV,50 -19-01OCT92

Abrasive particles in engine oil cause scratches on side rails (A) of oil control ring. Inner spacer (B) wear or distortion may cause:

- High oil consumption.
- Increased deposits in combustion chamber.
- Sticking compression rings.

Increased oil consumption may be caused by:

- Worn side rails with low tension.
- Worn or distorted inner spacer.

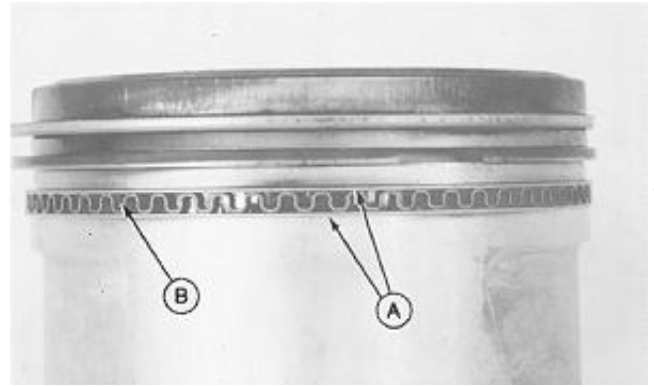

M38101 -UN-29AUG88

MX,2110BV,51 -19-01OCT92

ANALYZE PISTON WEAR

Detonation, is abnormal combustion causing excessive temperature and pressure in the combustion chamber. Commonly called carbon knock, spark knock or timing knock, detonation occurs as the compressed fuel-air mixture ignites spontaneously to interrupt the normal ignition.

The following is a list of possible causes for detonation:

- Lean fuel mixture.
- Low octane fuel.
- Advanced ignition timing.
- Engine lugging.
- Build-up of carbon deposits on piston or cylinder head, causing excessive compression.
- Wrong cylinder head or milling of head increasing compression ratio.



M29947 -UN-06SEP88

MX,10010A1,A2A -19-23OCT95

Pre-ignition is the igniting of the fuel-air mixture prior to regular ignition spark. Pre-ignition causes internal shock, resulting in pings, vibration, detonation and power loss. Severe damage to piston (A), rings and valves results from pre-ignition.

Check the following for causes of pre-ignition:

- Internal carbon deposits.
- Incorrect spark plug (high heat range).
- Broken ceramic in spark plug.
- Sharp edges on valves.



M30039 -UN-06SEP88

20
20
19

MX,2110BV,53 -19-01OCT92

Check rod and piston alignment when piston shows a diagonal wear pattern (A) extending across the skirt of the piston. Contact with the cylinder wall shows on bottom of skirt at left and ring lands on the right.

A cylinder bored at an angle to the crankshaft can also cause improper ring contact with the cylinder.

This condition causes:

- Rapid piston wear.
- Uneven piston wear.
- Excessive oil consumption.



M29948 -UN-06SEP88

MX,2110BV,54 -19-01OCT92

A broken spring clip caused the damage (A) shown.

Spring clips loosen or break due to:

- Rod misalignment.
- Excessive crankshaft end play.
- Crankshaft journal taper.
- Weak spring clips.
- Incorrectly installed spring clips.

Inertia can cause a broken spring clip to gouge out the piston and cylinder, causing extensive damage.



M29949 -UN-06SEP88

MX,2110BV,55 -19-01OCT92

INSPECT CONNECTING ROD

1. Clean and inspect rod. Replace if scored.
2. Analyze crankshaft and connecting rod wear. (See Analyze Crankshaft and Connecting Rod Wear in this group.)
3. Install connecting rod cap. Apply a light film of oil to connecting rod cap screws. Tighten to **20 N·m (177 lb-in.)**.
4. Measure connecting rod crankshaft bearing and piston bearing (A). Replace connecting rod if either measurement is greater than specifications.

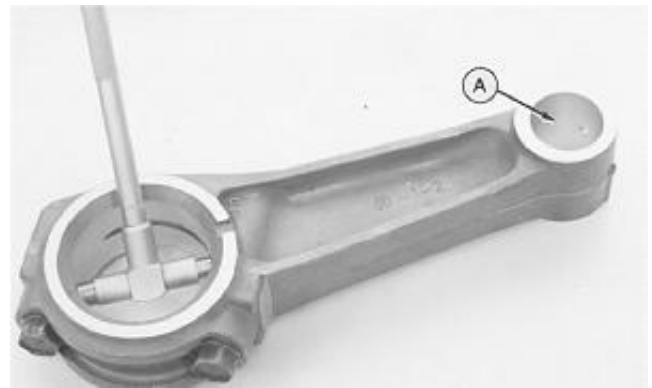

M50066 -UN-31AUG88

BEARING I.D. SPECIFICATIONS (MAXIMUM)

	Crankshaft Bearing	Piston Bearing
PA420A-AS00/BS00/ AS01/AS02		
PA540A-AS00/BS00/ AS01/AS02	41.07 mm (1.617 in.)	22.06 mm (0.868 in.)

MX,2020CL,A22 -19-23OCT95

ANALYZE CRANKSHAFT AND CONNECTING ROD WEAR

Check connecting rod and cap for damage or unusual wear patterns.

Lack of lubrication or improper lubrication can cause the connecting rod and cap to seize the crankshaft.

When the rod and cap seize to the crankshaft, the connecting rod and piston may both break causing other internal damage. Inspect block carefully before rebuilding engine.

Crankshaft and connecting rod damage can result from:

- Engine run low on oil or without oil.
- Oil not changed regularly.
- Bearing cap installed incorrectly.

MX.10010A1,A3 -19-23OCT95

20
20
21

REMOVE, INSPECT AND INSTALL CRANKSHAFT

1. Remove camshaft. (See Remove and Install Camshaft in this group.)
2. Remove piston and connecting rod. (See Remove and Install Piston and Connecting Rod in this group.)
3. Remove balancer. (See Remove and Install Reciprocating Balancer in this group.)
4. Remove crankshaft.

IMPORTANT: A bent crankshaft must be replaced; it cannot be straightened.

5. Check crankshaft alignment (TIR). (See Check Crankshaft Alignment (TIR) in this group.)
6. Clean and inspect crankshaft. Replace if parts are scratched or damaged.
7. Analyze crankshaft and connecting rod wear. (See Analyze Crankshaft and Connecting Rod Wear in this group.)
8. Measure crankshaft main bearing journals and connecting rod journal. Replace crankshaft if measurements are less than specifications.

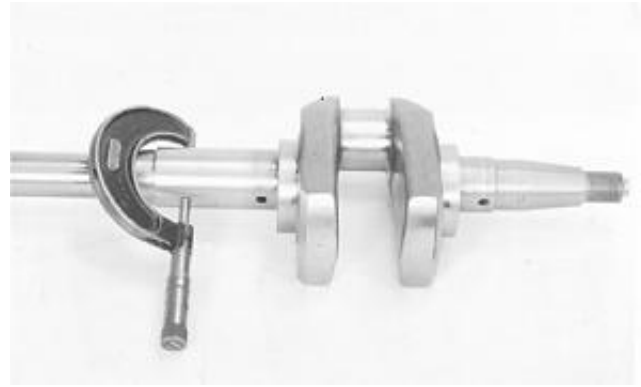

M54495 -UN-09JAN91

JOURNAL SPECIFICATIONS (MINIMUM)

	Main Bearing Journal		Connecting Rod Journal
	PTO Side	Flywheel Side	
PA420A	34.92 mm (1.375 in.)	34.95 mm (1.376 in.)	40.93 mm (1.611 in.)
PA540A	37.90 mm (1.492 in.)	34.95 mm (1.376 in.)	40.93 mm (1.611 in.)

MX,2020CL,A25 -19-23OCT95

NOTE: An under-sized connecting rod is available through the parts catalog, if necessary.

9. Connecting rod journal (A) can be resized to accept under-sized rod. Have grinding done by a reliable repair shop. Before sending crankshaft for grinding, inspect journal radii (B) for cracks.
10. Cover keyway on flywheel end of crankshaft with tape to prevent seal damage when installing crankshaft.
11. Put a light film of oil on crankshaft bearing surfaces.
12. Apply a light coat of engine oil to oil seals and install crankshaft.

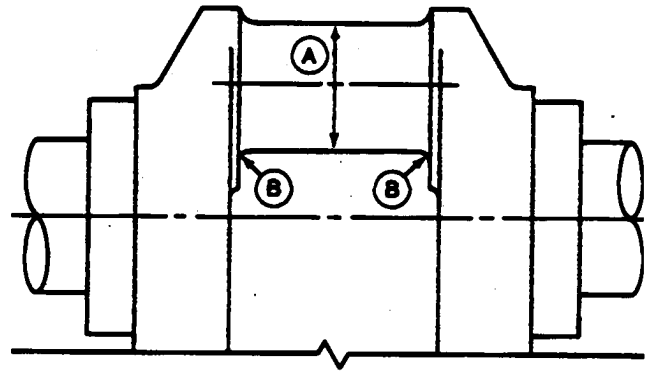

M38036
-UN-29AUG88

20
20
23

MX,2020CL,A25A -19-23OCT95

REGRIND CRANKSHAFT

IMPORTANT: If crank pin is re-ground, under-size connecting rod must be used to keep specified clearance. Severe engine damage could result if incorrectly sized connecting rod is used.

NOTE: Crank pin must be concentric and parallel within 0.005 mm (0.002 in.) full indicator reading, and surface must be finished very smooth with super fine finishing stone.

1. Regrind crank pin to specified under-size.

SPECIFICATIONS

PA420A

- A—33.950 - 34.000 mm (1.3366 - 1.3386 in.)
- B—40.467 - 40.480 mm (1.5932 - 1.5937 in.)
- C—3.30 - 3.70 mm (0.130 - 0.146 in.)
- D—32.5 mm (1.28 in.) MAXIMUM

PA540A

- A—42.950 - 43.000 mm (1.6909 - 1.6929 in.)
- B—40.467 - 40.480 mm (1.5932 - 1.5937 in.)
- C—3.30 - 3.70 mm (0.130 - 0.146 in.)
- D—32.5 mm (1.28 in.) MAXIMUM

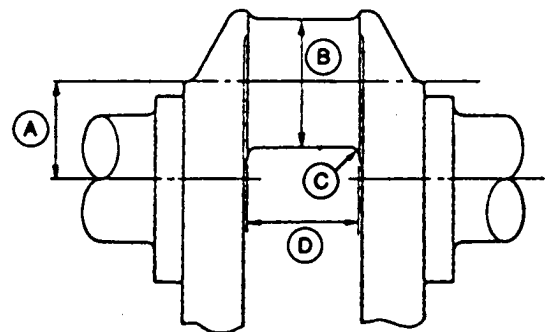

M53094
-UN-21AUG89

MX,2030CL,A15 -19-23OCT95

INSPECT CRANKSHAFT PLAIN BEARING

1. Remove crankshaft. (See Remove and Install Crankshaft in this group.)
2. Measure crankshaft bearing in crankcase cover. Replace cover if diameter is greater than specifications.
3. Install crankshaft.

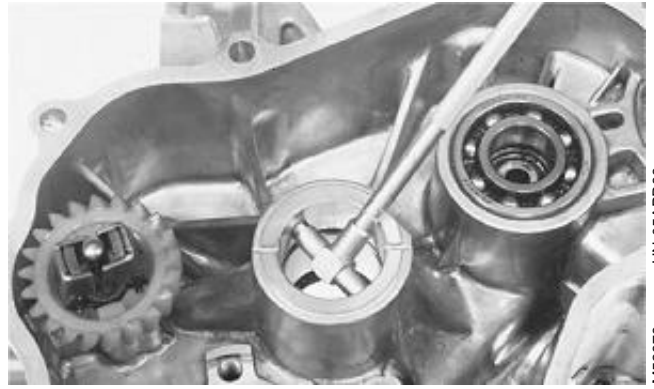

M52979 -UN-05APR89

BEARING I.D. SPECIFICATIONS (MAXIMUM)

PA420A	35.07 mm (1.381 in.)
PA540A	38.06 mm (1.498 in.)

MX,2020CL,A26 -19-23OCT95

20
20
24

INSPECT CRANKSHAFT BALL BEARING

1. Remove flywheel and oil seal. (See Inspect Oil Seals in this group.)
2. Remove crankshaft bearing using a bearing, bushing and seal driver set.
3. Thoroughly clean bearing in solvent. Dip bearing in light weight oil.
4. Spin the bearing by hand and check for axial (A) and radial (B) free play.
5. Replace the bearing if it is noisy or has too much play. The bearing is a press fit into crankcase. Check crankcase bore for damage from spun bearing. Replace crankcase if necessary.
6. Install bearing flush to inside of crankcase using a bearing, bushing and seal driver set.
7. Install oil seal.

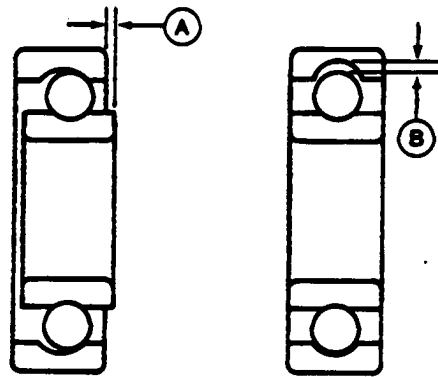

M38073 -UN-29AUG88

BALL BEARING O.D. SPECIFICATION

New Part	79.98-80.00 mm (3.149-3.150 in.)
--------------------	----------------------------------

MX,2020CL,A28 -19-23OCT95

CHECK CRANKSHAFT ALIGNMENT (TIR)

Place crankshaft into an alignment jig and rotate crankshaft slowly. Use dial indicators (A) to measure maximum total indicated runout (TIR). If runout exceeds **0.05 mm (0.002 in.)**, replace crankshaft.

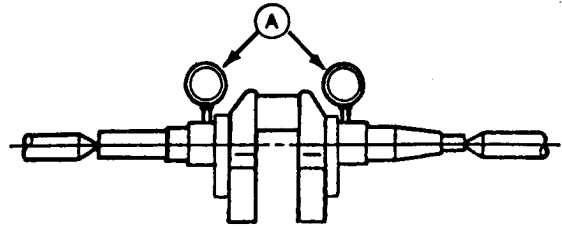

MX,2020CL,A29 -19-23OCT95

M80432 -UN-08MAY91

20
20
25

MEASURE CRANKSHAFT END PLAY

1. Measure end play using dial indicator (A). Record this measurement.
2. Move crankshaft in and out. Remove crankcase cover and adjust end play if not within **0.09—0.22 mm (0.004—0.009 in.)**. (See Adjust Crankshaft End Play in this group.)

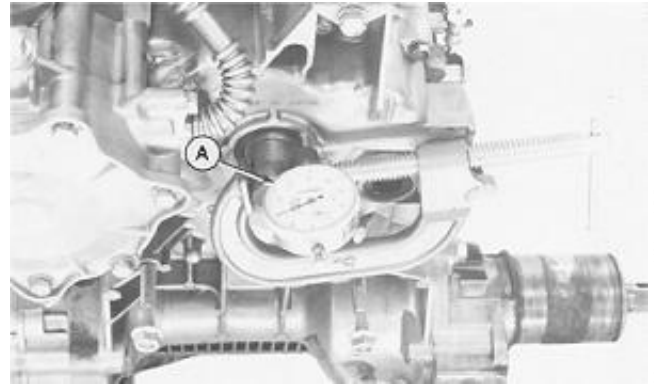

MX,2020CL,A30 -19-23OCT95

M53042 -JUN-13APR89

ADJUST CRANKSHAFT END PLAY

1. With gasket (A) installed on crankcase, measure from gasket surface to crankshaft gear surface (B). Record measurement (C).
2. Measure from crankcase cover mounting face (D) to PTO bearing end (E). Record measurement (F).
3. Locate measurements on appropriate table. Follow lines to where recorded measurements intersect. Choose the next smaller shim from the table.
4. Install shim on PTO shaft.
5. Install crankcase cover. (See Remove and Install Crankcase Cover in this group.)

- A—Gasket
- B—Crank Gear Surface
- C—Measurement
- D—Crankcase Cover Mounting Face
- E—PTO Bearing End
- F—Measurement

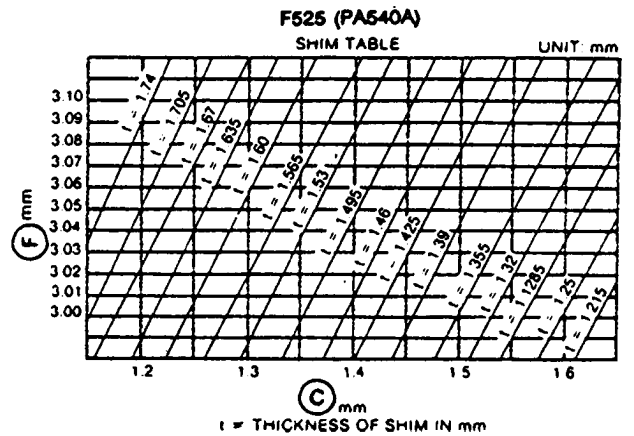
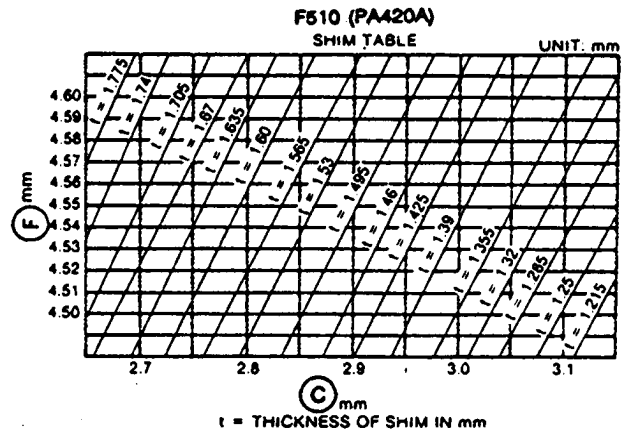
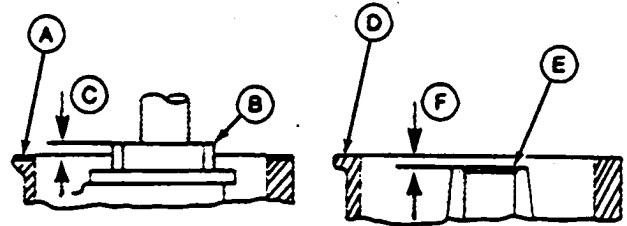

MX,2020CL,A31 -19-23OCT95

20
20
26

-UN-31AUG88

M51545

-19-27APR89

M53081

-19-27APR89

M53082

INSPECT OIL SEALS

NOTE: Pack lithium base grease in new or used seals.

1. Remove flywheel. (See Remove and Install Flywheel in Group 10.)
2. Inspect oil seals (A and B) at flywheel end and PTO end. Replace if necessary.
3. Remove crankshaft. (See Remove, Inspect and Install Crankshaft in this group.)
4. Remove worn or damaged seals with a screwdriver.
5. Install seals with lip to inside of engine using a bearing, bushing and seal driver set. Press seals in until flush with hub.

On PA540A engine, press in seal on PTO side to a depth of **0.50 mm (0.020 in.) below crankcase cover flange surface.**

6. Install crankshaft.

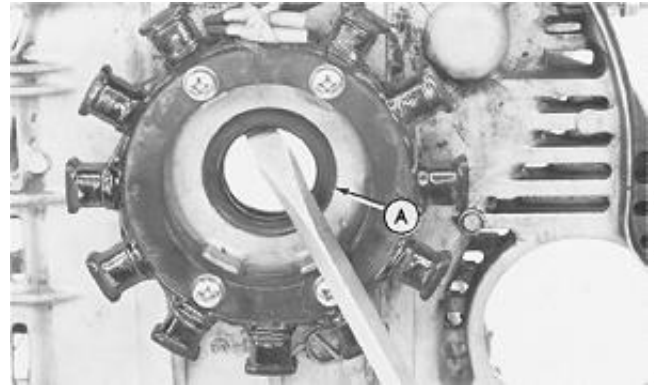

Flywheel End

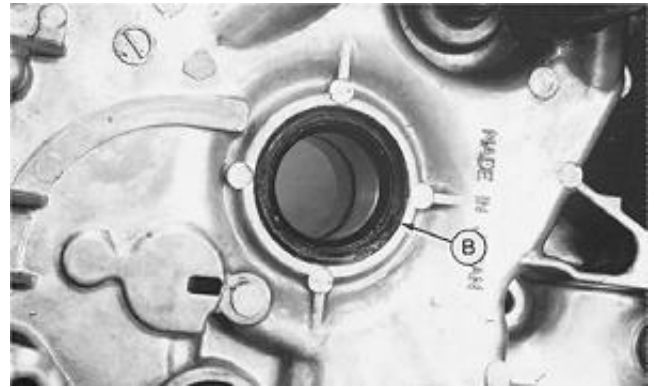

PTO End

MX,2020CL,A32 -19-23OCT95

M52980 -UN-05APR89

20
20
27

M52981 -UN-05APR89

20
20
28

INSPECT CYLINDER BLOCK

1. Remove crankshaft.
2. Clean and check block for cracks.
3. Cracks not visible to the eye may be detected by coating the suspected area with a mixture of 25 percent kerosene and 75 percent light engine oil.
4. Wipe area dry and immediately apply coating of zinc oxide dissolved in wood alcohol. If crack is present, coating becomes discolored at the defective area. Replace block if any cracks are found.

MX,2020CL,A33 -19-23OCT95

NOTE: A bare block is available for service.

5. Measure cylinder bore parallel with crankshaft and right angles to crankshaft at top and bottom of ring travel.
6. If cylinder bore exceeds wear limit, replace cylinder block or rebore cylinder. (See Rebore Cylinder Block in this group.)

NOTE: If cylinder is rebored, oversize piston and rings must be installed.

7. Install crankshaft.

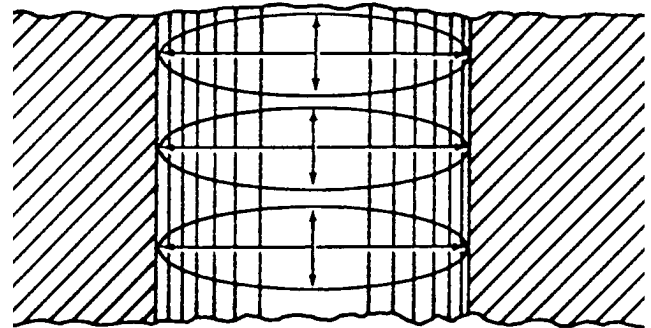

M51745 -UN-23FEB89

CYLINDER BORE SPECIFICATIONS

	Standard	Wear Limit
PA420A	88.98—89.00 mm (3.503—3.504 in.)	89.08 mm (3.507 in.)
PA540A	88.98—89.00 mm (3.503—3.504 in.)	89.08 mm (3.507 in.)

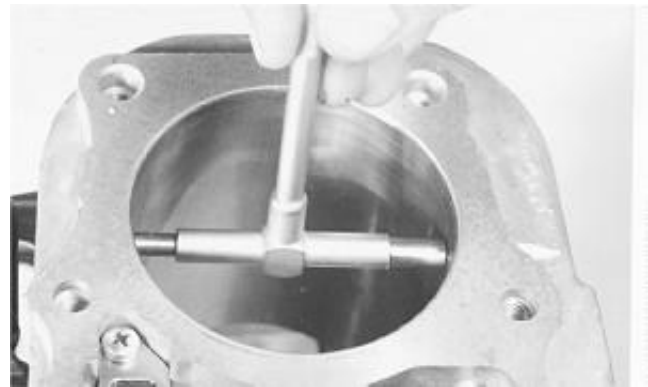

M54496 -UN-09JAN91

MX,2020CL,A34 -19-23OCT95

DEGLAZE CYLINDER BORE

1. Deglaze cylinder bore using a rigid hone with a 220 to 300 grit stone.

NOTE: A cutaway of a cylinder bore is shown for clarity.

2. Use hone as instructed by manufacturer to obtain 45° crosshatch pattern as shown.

IMPORTANT: DO NOT use gasoline, kerosene, or commercial solvent to clean cylinder bores. Solvents will not remove all abrasives from cylinder walls.

3. Clean cylinder walls using clean white rags and water. Continue to clean cylinder until white rags show no discoloration.

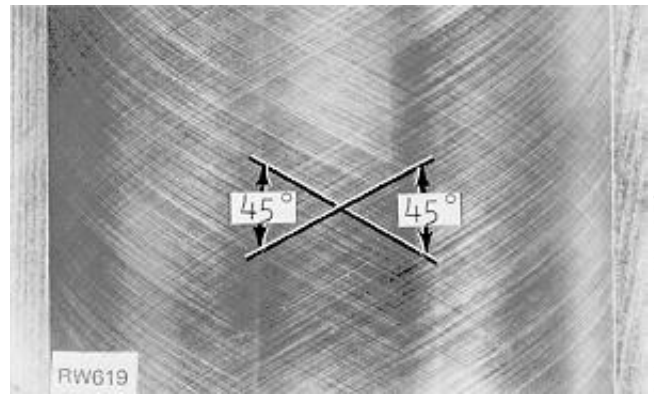

RW619
-UN-02DEC88

20
20
29

MX,10015A1,A1 -19-23OCT95

REBORE CYLINDER BLOCK

NOTE: The cylinder block can be rebored to use 0.50 mm (0.020 in.) oversize piston and rings. Have a reliable repair shop rebore the block, or use the drill press and honing tool.

IMPORTANT: The 0.25 or 0.75 mm (0.010 or 0.030 in.) oversize pistons and rings are NOT available as service parts.

1. Rebore cylinder with a honing tool to initial and final bore specifications.
2. Align center of bore to press center. Set the press to operate from 200—250 rpm.
3. Lower and raise hone until ends extend 20—25 mm (0.75—1.0 in.) past ends of cylinder.
4. Turn adjusting nut on one hone until stones contact cylinder wall at narrowest point.
5. Coat inside of cylinder with honing oil. Turn hone by hand. If you cannot turn it, hone is too tight.
6. Start drill press. Move hone up and down in cylinder approximately 20 times per minute.
7. Check cylinder diameter regularly during honing. Stop press before measuring. Remove hone from cylinder.

NOTE: Finish should not be smooth, but have a 40—60° cross-hatch pattern.

IMPORTANT: Check stone for wear or damage. Use correct stone for the job.

CYLINDER INITIAL BORE SPECIFICATIONS

Piston Oversize:
0.50 mm
(0.020 in.)

PA420A	89.48—89.50 mm (3.523—3.524 in.)
PA540A	89.46—89.48 mm (3.522—3.523 in.)

SPECIFICATIONS

Piston-to-Cylinder Bore Clearance

PA540A	0.110—0.151 mm (0.0043—0.0059 in.)
PA420A	0.13—0.17 mm (0.005—0.0067 in.)

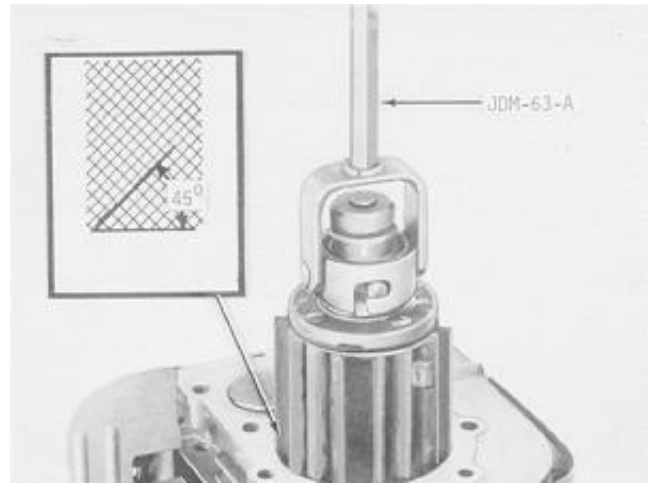

M24711 -UN-25AUG88

20
20
30

8. Hone the cylinder an additional 0.028—0.030 mm (0.0011—0.0012 in.) for final bore specifications. This allows for 0.020 mm (0.0008 in.) shrinkage when cylinder cools.

IMPORTANT: DO NOT use gasoline or commercial solvents to clean cylinder bores. Solvents will not remove metal particles produced during honing.

9. Clean the cylinder thoroughly using soap, warm water and clean rags. Continue to clean cylinder until white rags show no discoloration.

10. Dry the cylinder. Apply engine oil to cylinder wall.

M98,2040A,A9 -19-23OCT95

DISASSEMBLE AND ASSEMBLE OIL PUMP—PA420A

1. Remove crankcase cover. (See Remove and Install Crankcase Cover in this group.)

2. Remove oil pump gear (A).

IMPORTANT: Remove rotor shaft and oil pump cover together to avoid damaging governor.

3. Remove oil pump assembly (B).

4. Remove relief spring and ball (C).

5. Inspect all parts. (See Inspect Oil Pump—PA420A in this group.)

NOTE: Install gear (A) with recess facing away from crankcase cover.

6. Install oil pump assembly.

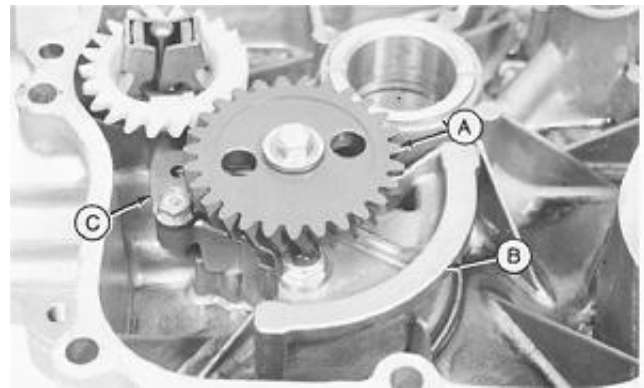

20
20
31

M80018
-UN-09JAN91

MX,2020CL,A38 -19-23OCT95

INSPECT OIL PUMP—PA420A

1. Inspect all parts for wear or damage. Replace as necessary.

- A—Plate
- B—Spring
- C—Ball
- D—Gear
- E—Cover
- F—Screen
- G—Outer Rotor
- H—Rotor Shaft With Gear

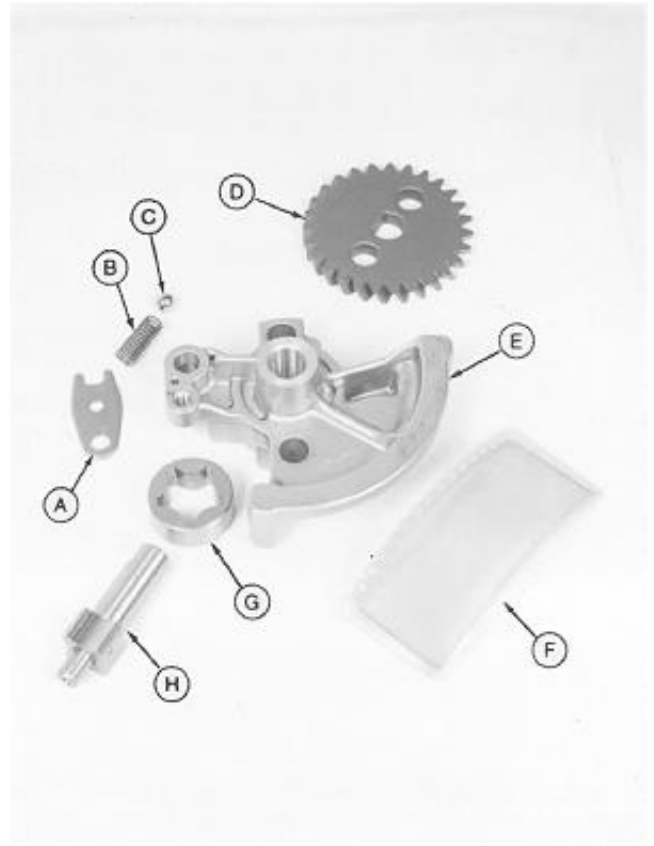

MX,2020CL,A39 -19-23OCT95

M80019 -JUN-09JAN91

2. Measure outside diameters of shaft. Replace both shaft and outer rotor if less than specification.

SPECIFICATIONS

Minimum Shaft O.D.	
Large O.D.	12.63 mm (0.497 in.)
Small O.D.	7.94 mm (0.313 in.)



MX,2020CL,A40 -19-04MAY92

M80150 -JUN-09JAN91

3. Measure rotor shaft bearings. Replace oil pump cover or crankcase cover if greater than specifications.

SPECIFICATIONS

Maximum Rotor Shaft Bearing I.D.	
Oil Pump Cover	12.76 mm (0.502 in.)
Crankcase Cover	8.07 mm (0.318 in.)

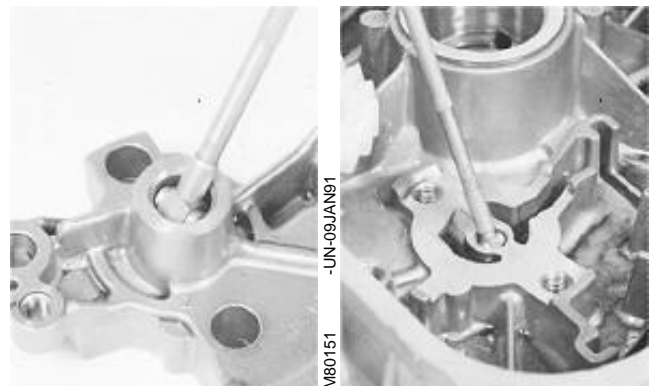

MX,2020CL,A41 -19-04MAY92

M80151 -JUN-09JAN91

M80152 -JUN-09JAN91

4. Measure thickness of outer rotor. Replace both outer rotor and shaft if less than **11.92 mm (0.470 in.)**.

5. Measure outer rotor bearing depth (A). Replace oil pump cover if greater than **12.14 mm (0.478 in.)**.

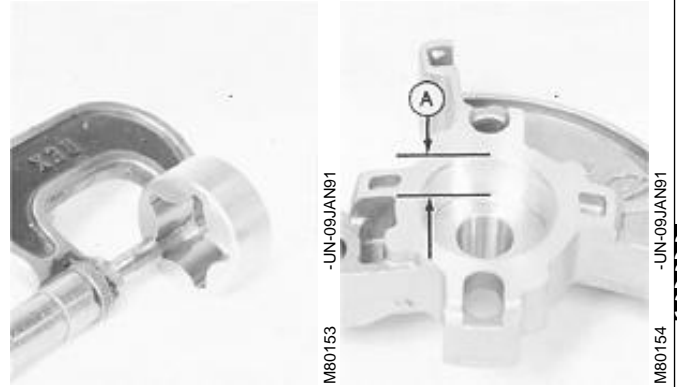

MX,2020CL,A42 -19-23OCT95

6. Measure inside diameter of rotor bearing. Replace oil pump cover if greater than **29.20 mm (1.149 in.)**.

7. Measure outside diameter of rotor. Replace both rotor and shaft if less than **28.95 mm (1.140 in.)**.

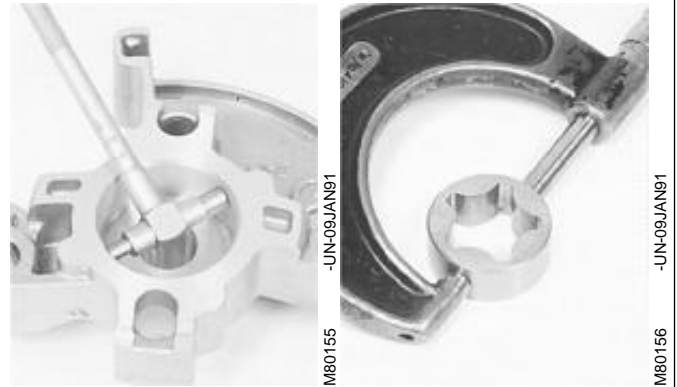

MX,2020CL,A43 -19-23OCT95

8. Measure relief valve spring. Replace if free length is less than **19.00 mm (0.750 in.)**.



MX,2020CL,A44 -19-23OCT95

DISASSEMBLE AND ASSEMBLE OIL PUMP—PA540A

1. Remove crankcase cover. (See Remove and Install Crankcase Cover in this group.)
2. Remove oil pump gear (A).

IMPORTANT: Remove rotor shaft and oil pump cover together to avoid damaging governor.

3. Remove oil pump assembly (B).
4. Remove relief spring and ball (C).
5. Inspect all parts. (See Inspect Oil Pump—PA540A in this group.)

IMPORTANT: Install outer rotor with dimple (D) facing away from crankcase cover, to avoid oil pump damage.

NOTE: Install gear (A) with recess facing away from crankcase cover.

6. Install oil pump assembly.

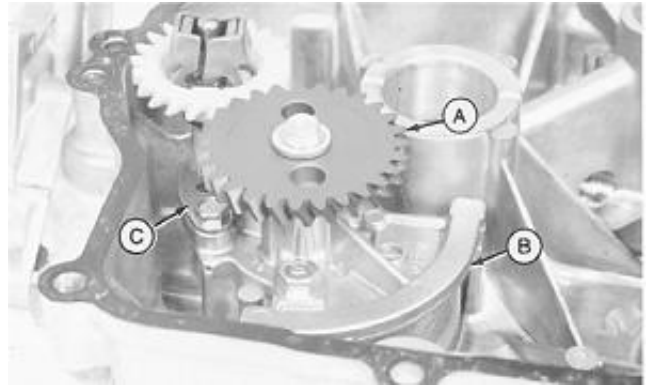

M80011
-UN-09JAN91



M80012
-UN-09JAN91

- A—Oil Pump Gear
- B—Oil Pump Assembly
- C—Relief Spring and Ball
- D—Dimple

MX,2020CL,A45 -19-23OCT95

INSPECT OIL PUMP—PA540A

1. Inspect all parts for wear or damage. Replace as necessary.

- A—Plate
- B—Spring
- C—Ball
- D—Gear
- E—Cover
- F—Screen
- G—Rotor Shaft With Gear
- H—Outer Rotor

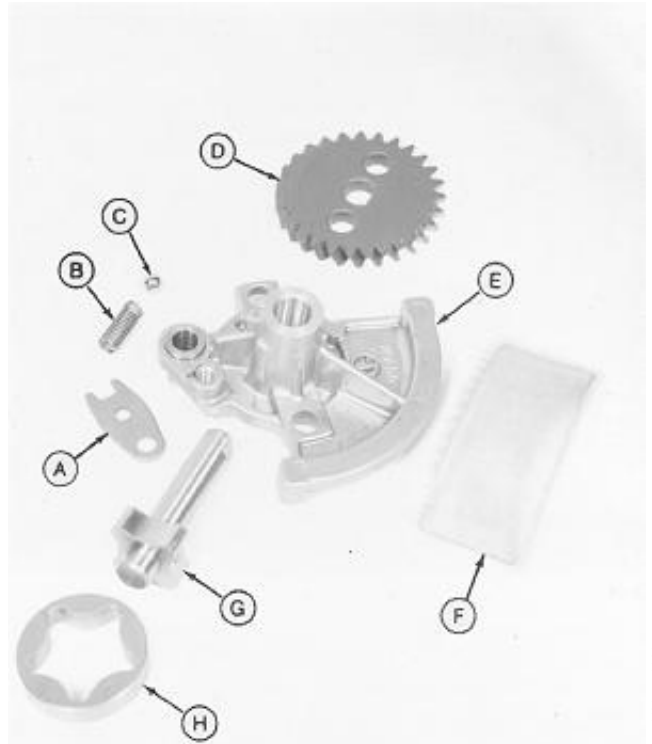

MX,2020CL,A46 -19-23OCT95

M80013 -JUN-09/JAN91

2. Measure outside diameters of shaft. Replace both shaft and outer rotor if less than **12.63 mm (0.497 in.)**.



MX,2020CL,A47 -19-23OCT95

M50084 -JUN-31/AUG88

3. Measure rotor shaft bearings. Replace oil pump cover or crankcase cover if greater than **12.76 mm (0.502 in.)**.



M50089 -UN-31AUG88



M80014 -UN-09JAN91

MX,2020CL,A48 -19-23OCT95

4. Measure thickness of outer rotor. Replace both outer rotor and shaft if less than **9.92 mm (0.391 in.)**.

5. Measure outer rotor bearing depth (A). Replace crankcase cover if greater than **10.17 mm (0.401 in.)**.



M80015 -UN-22JAN91

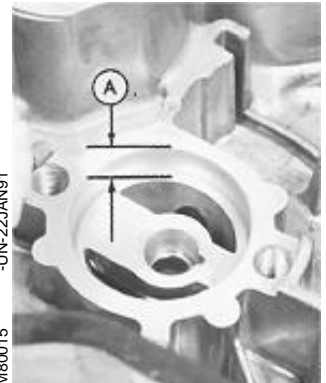

M80016 -UN-09JAN91

MX,2020CL,A49 -19-23OCT95

6. Measure inside diameter of rotor bearing. Replace crankcase cover if greater than **40.77 mm (1.605 in.)**.

7. Measure outside diameter of rotor. Replace both rotor and shaft if less than **40.47 mm (1.596 in.)**.

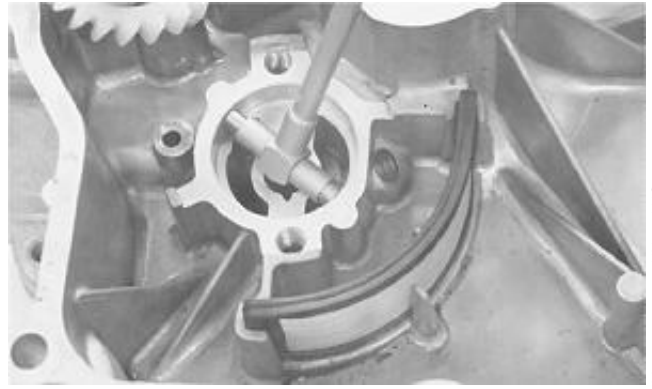

M50090 -UN-31AUG88



M80017 -UN-09JAN91

MX,2020CL,A50 -19-23OCT95

8. Measure relief valve spring. Replace if free length is less than **19.00 mm (0.750 in.)**.



M50083 -UN-31AUG88

MX,2020CL,A44 -19-23OCT95

REMOVE, INSPECT AND INSTALL OIL FILTER MANIFOLD

1. Remove oil filter and manifold.
2. Inspect oil filter. Replace if excessively contaminated or damaged.
3. Inspect oil passages for clogs. Clean if needed.
4. Replace rubber gaskets everytime manifold is removed.
5. Install filter and manifold.



M50077 -UN-31AUG88

MX,2020CL,A51 -19-23OCT95

INSPECT AND REPLACE GOVERNOR

IMPORTANT: DO NOT remove governor assembly unless worn or damaged. Removal damages the assembly.

1. Remove crankcase cover. (See Remove and Install Crankcase Cover in this group.)
2. Check governor gear, sleeve, and flyweights for binding. If necessary to replace, remove with screwdriver.
3. If removed, press shaft (C) back into block until it protrudes **32.2—32.8 mm (1.267—1.291 in.)**.

NOTE: Assemble sleeve and gear before installing assembly on shaft.

4. Install sleeve (A) inside flyweights of governor gear (B).
5. Install governor assembly onto shaft (C). Push down on assembly until it snaps into place. Check sleeve for free movement.

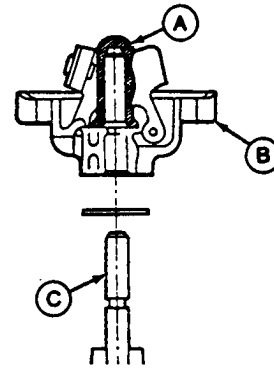

M51762 -UN-07SEP88

MX,2020CL,A52 -19-23OCT95

INSPECT AND REPLACE GOVERNOR ARM

NOTE: It is not necessary to remove governor shaft unless damaged.

1. Remove crankcase cover. (See Remove and Install Crankcase Cover in this group.)
2. Inspect arm (A). Replace if damaged.
3. To replace shaft, loosen nut (B) on lever (C).
4. Remove retaining pin (D), governor shaft and washer (E).
5. Install washer, shaft and retaining pin. Tighten nut to **7 N·m (62 lb-in.)**.

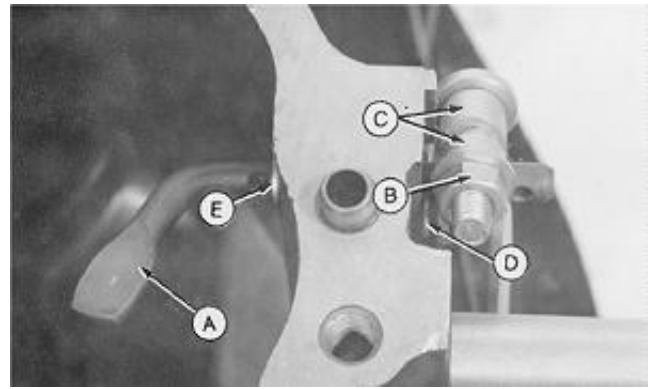

A—Governor Arm
B—Nut
C—Governor Lever
D—Retaining Pin
E—Washer

MX,2020CL,A53 -19-23OCT95

M50094 -UN-31AUG88

20
20
39

20
20
40

Section 30

FUEL AND AIR SYSTEM REPAIR

Contents

Page

Group 05—Fuel Tank

Remove and Install Fuel Tank	30-05-1
Repair Fuel Tank	30-05-2

Group 10—Fuel Pump 30-10-1

Group 15—Air Cleaner

Service Air Cleaner	30-15-1
-------------------------------	---------

Group 20—Carburetor

Engine Configuration Chart	30-20-1
Service Parts Kits	30-20-1
Remove and Install Carburetor	
PA420A	30-20-2
PA540A	30-20-4
Disassemble, Clean Inspect and Assemble Carburetor—PA420A	
Disassemble, Clean Inspect and Assemble Carburetor—PA540A	
Adjust Float	30-20-10
Service Breather	30-20-11

30

OTHER MATERIAL

Number	Name	Use
	PERMATEX® High Tack Adhesive Sealant	Seal Fuel Tank Fitting

PERMATEX is a trademark of the Loctite Corp.

MX,3005CL,A2 -19-04MAY92

REMOVE AND INSTALL FUEL TANK

⚠ CAUTION: Gasoline is explosive. DO NOT expose to spark or flame. Serious personal injury may result. Wipe-up any spilled fuel IMMEDIATELY. Allow engine to cool completely before working on exhaust or fuel system.

NOTE: Fender removed for photo clarity only.

1. Turn fuel shutoff valve (B) to **OFF** position.
2. Disconnect fuel hose (C). Drain fuel into a suitable container.
3. Disconnect sensor (A).
4. Remove fuel tank cap.
5. Remove nuts and washers (D) and (E).
6. Remove fuel tank.
7. Install fuel tank and cap.
8. Install nuts and washers.
9. Connect fuel hose.
10. Connect sensor.
11. Turn fuel shutoff valve to open position.

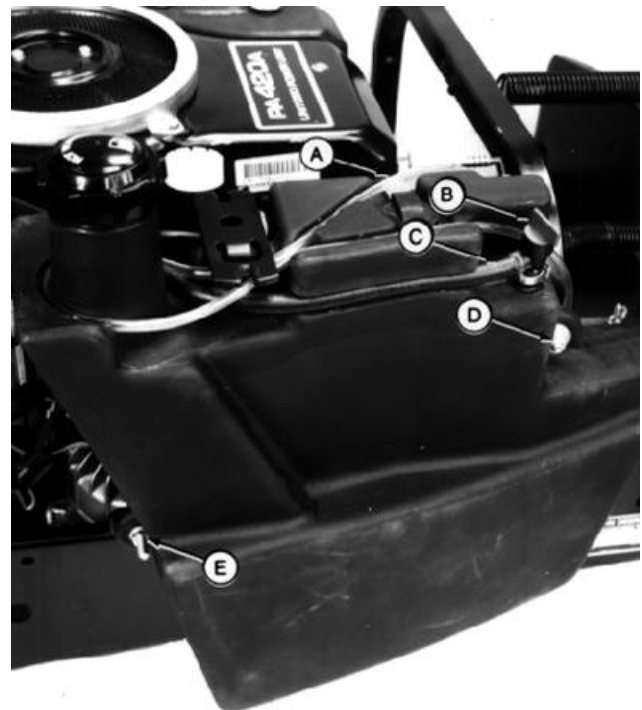

A—Low Fuel Sensor
 B—Fuel Shutoff
 C—Fuel Hose
 D—Lock Nut, Washer and Cap Screw
 E—Flange Nut and Carriage Bolt

-JUN-29APR95

M63043

MX,3005CL,A1 -19-23OCT95

REPAIR FUEL TANK

1. Pry sensor (A) from fuel tank.
2. Inspect bushing (B). Replace if damaged.
3. Remove fitting (C) and valve (D) if necessary.
4. Install sensor (A), fitting (C) and valve (D) using PERMATEX® High Tack sealant.

A—Low Fuel Sensor
B—Bushing
C—Elbow Fitting
D—Fuel Shut-Off Valve

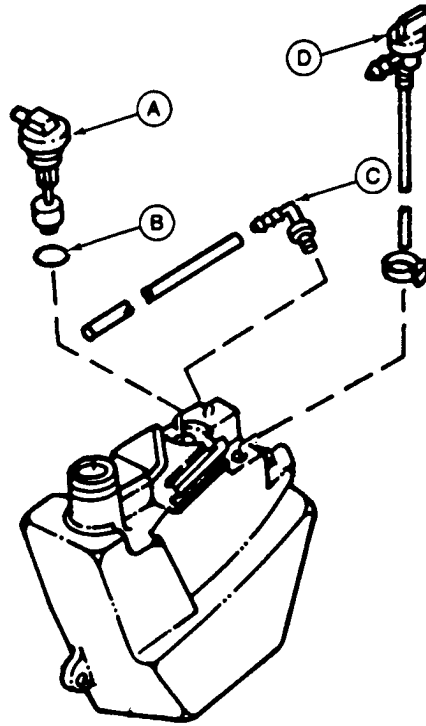

MX,3005CL,A3 -19-04MAY92

M53091 -JUN-20APR89

REMOVE AND INSTALL FUEL PUMP

⚠ CAUTION: Gasoline is dangerous. Avoid fires due to smoking or careless maintenance practices.

NOTE: Fender removed for clarity.

1. Turn fuel shutoff valve to **OFF** position.
2. Disconnect vacuum line (A) and fuel lines (B). Close all openings with caps or plugs.
3. Remove fuel pump.

NOTE: The fuel pump does not have any internal serviceable parts. Replace fuel pump as an assembly.

4. Inspect pump for cracks or damage.
5. Install fuel pump. Be sure fiber washers (C), if equipped, are installed on each side of flange.
6. Connect vacuum and fuel lines and turn fuel shutoff valve to **ON** position.

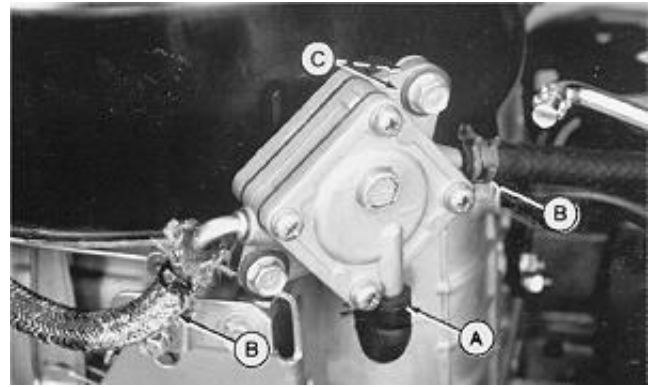

M53044 -UN-13APR89

30
10
1

MX,3010CL,A1 -19-23OCT95

Fuel Pump

30
10
2

SERVICE AIR CLEANER

NOTE: Replace elements yearly or every 25 hours as required.

1. Remove and disassemble air cleaner.

IMPORTANT: Do not clean elements with solvent or compressed air.

2. Wash foam element (A) in detergent and water. Dry element.

3. Put 12-15 drops of engine oil on foam element (A). Squeeze out excess oil.

4. Gently tap paper element (B) to remove dust:

- Element is still usable if you can see light through element and paper appears clean.
- Install new element if element is oily, dirty, bent, torn, crushed, or obstructed in any way.

5. Inspect body (C), and gasket (D), and base (E) for damage. Replace if necessary.

IMPORTANT: Any time air cleaner base is removed, check for free choke operation during reassembly.

6. Assemble and install air cleaner.

7. Check breather hose for hardness, splits and holes. Replace if necessary.

8. Apply silicone sealant on outside diameter of breather hose at end that fits into base to prevent entry of dirt. Install breather hose.

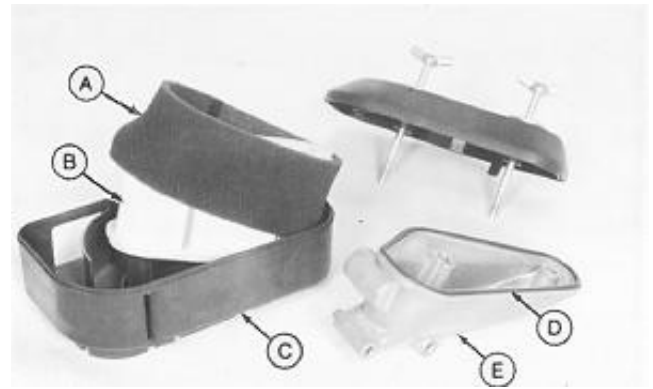

A—Foam Element
B—Paper Element
C—Body
D—Gasket
E—Base

M80157 -UN-09JAN91

30
15
1

MX,3015CL,A1 -19-23OCT95

30
15
2

ENGINE CONFIGURATION CHART

The PA420A and PA540A engines have an engine configuration number following the engine model number to help separate engine changes. Use the engine configuration number to determine the proper service specifications and procedures to follow in this technical manual.

ENGINE CONFIGURATION CHART

F510 (Engine S.N. -3887)	PA420A-AS00
(Engine S.N. 3888-4898)	PA420A-BS00
(Engine S.N. 4899-7322)	PA420A-AS01
(Engine S.N. 7323-)	PA420A-AS02
F525 (Engine S.N. -7891)	PA540A-AS00
(Engine S.N. 7892-11999)	PA540A-BS00
(Engine S.N. 12000-21944)	PA540A-AS01
(Engine S.N. 21945-)	PA540A-AS02

MX,1015CL,1 -19-23OCT95

SERVICE PARTS KITS

The following kits are available through your parts catalog:

Carburetor:

- Gasket Kit
- Needle Valve
- Float Kit
- Choke Shaft Kit
- Throttle Shaft Kit
- Breather Valve Kit
- Air Cleaner Assembly
- Main Jet High Altitude Kit

MX,3020CL,1 -19-23OCT95

30
20
1

REMOVE AND INSTALL CARBURETOR—PA420A

⚠ CAUTION: Gasoline is explosive. **DO NOT** expose to spark or flame. Serious personal injury may result. Wipe-up any spilled fuel **IMMEDIATELY**. Allow engine to cool completely before working on exhaust or fuel system.

NOTE: Early model shown. Other models similar.

1. Turn fuel shutoff valve to **OFF** position.
2. Disconnect fuel hose (C).
3. Remove two nuts (D) and washer (B).
4. Disconnect wiring lead (E) and fuel shutoff solenoid lead.
5. Remove air cleaner assembly (A).

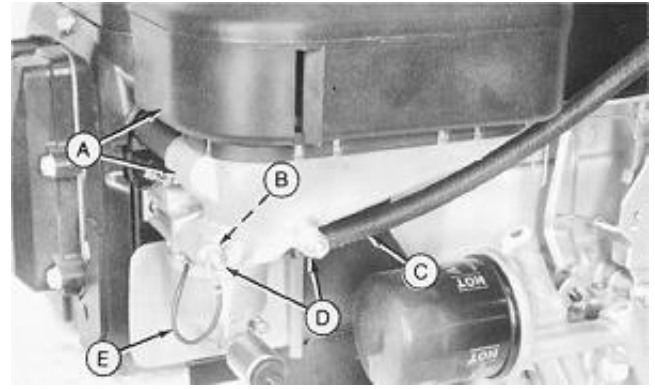

M80003 -UN-09JAN91

A—Air Cleaner Assembly
B—Washer
C—Fuel Hose
D—Nuts
E—Ground Wiring Lead

MX,3020CL,2 -19-23OCT95

6. Separate carburetor from heat shield (C). Remove carburetor.
 7. Disconnect choke linkage (B) and throttle control linkage (A).
 8. Remove heat shield (C) and gaskets (D, E and F).
 9. Make repairs as necessary. (See Disassemble, Clean, Inspect and Assemble Carburetor—PA420A in this group.)
 10. Install new gaskets and original heat shield, if not damaged.
 11. Connect throttle and choke linkages and install carburetor.
- NOTE: Install gasket (E) with hole (G) pointing toward fuel inlet side of carburetor and tab (H) pointing up.*
12. Install gasket (E) and air cleaner assembly.
 13. Connect wiring lead.
 14. Install washer and two nuts.
 15. Connect fuel hose.
 16. Turn fuel shutoff valve to **ON** position.

- A—Throttle Control Linkage
- B—Choke Linkage
- C—Heat Shield
- D—Outside Gasket (between heat shield and carburetor)
- E—Gasket
- F—Inside Gasket (between engine and heat shield)
- G—Hole
- H—Tab

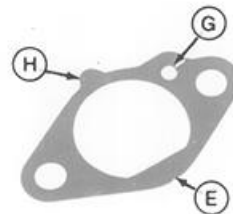
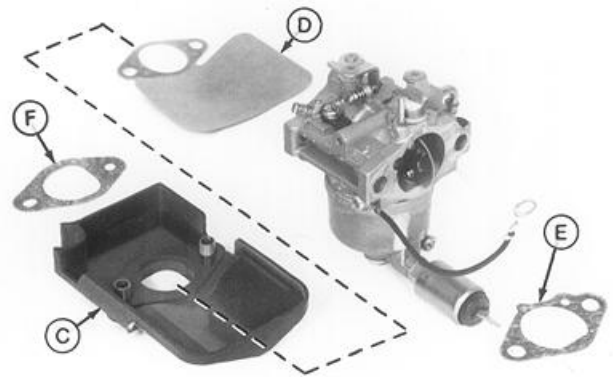
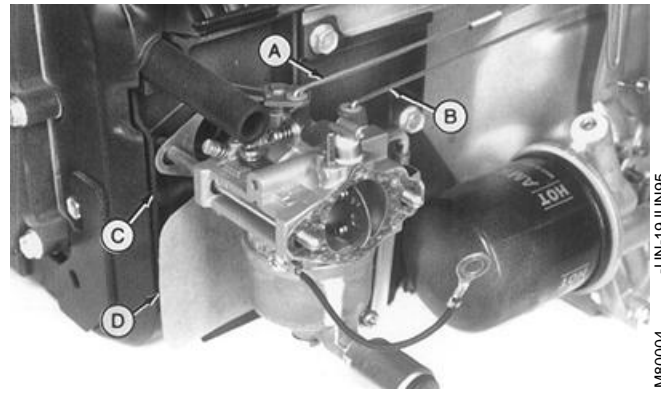

M80004 -UN-19JUN95

M80005 -UN-19JUN95

M80006 -UN-19JUN95

REMOVE AND INSTALL CARBURETOR—PA540A

⚠ CAUTION: Gasoline is explosive. **DO NOT** expose to spark or flame. Serious personal injury may result. Wipe-up any spilled fuel **IMMEDIATELY**. Allow engine to cool completely before working on exhaust or fuel system.

NOTE: Early model shown. Other models similar.

1. Turn fuel shutoff valve to **OFF** position.
2. Disconnect fuel hose (C).
3. Remove two nuts (D) and washer (B).
4. Disconnect wiring lead (E) and fuel shutoff solenoid lead.
5. Remove air cleaner assembly (A).

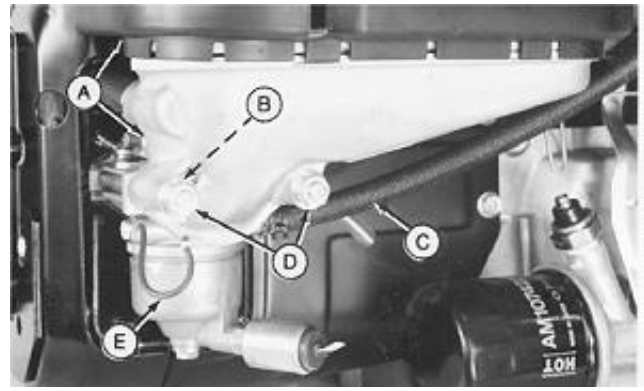

M54484 -UN-09JAN91

A—Air Cleaner Assembly
B—Washer
C—Fuel Hose
D—Nuts
E—Ground Wiring Lead

MX,3020CL,4 -19-23OCT95

6. Separate carburetor from heat shield (C). Remove carburetor.
7. Disconnect choke linkage (B) and throttle control linkage (A).
8. Remove heat shield (C) and gaskets (D, E and F).
9. Make repairs as necessary. (See Disassemble, Clean, Inspect and Assemble Carburetor—PA540A.)
10. Install new gaskets and original heat shield, if not damaged.
11. Connect throttle and choke linkages and install carburetor.
12. Install air cleaner assembly.
13. Connect wiring lead.
14. Install washer and two nuts.
15. Connect fuel hose.
16. Turn fuel shutoff valve to **ON** position.

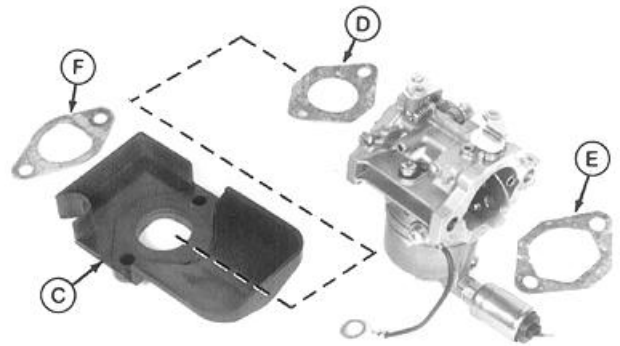
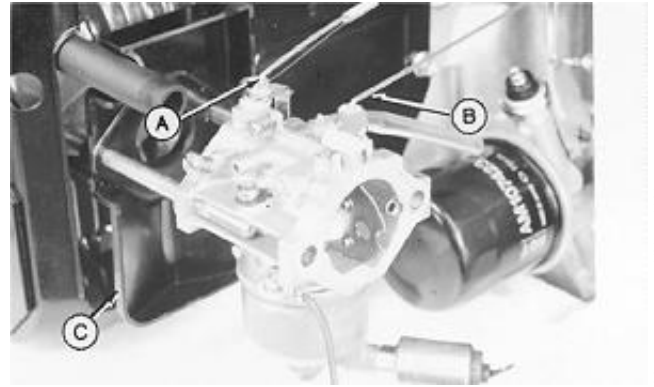

- A—Throttle Linkage
- B—Choke Linkage
- C—Heat Shield
- D—Outside Gasket (between heat shield and carburetor)
- E—Gasket
- F—Inside Gasket (between engine and heat shield)

DISASSEMBLE, CLEAN, INSPECT AND ASSEMBLE CARBURETOR—PA420A

1—Collar	14—Spring	27—Main Jet (AS00, BS00 and AS01)*	36—Fuel Shutoff Solenoid (AS00, BS00 and AS01)*
2—Seal	15—Idle Screw	28—Float	37—Washer
3—Spring	16—Throttle Shaft	29—Gasket	38—Float Pin
4—Collar	17—Throttle Plate	30—Float Chamber	39—Clip
5—Choke Plate	18—Screw (2 used)	31—O-Ring (AS00, BS00 and AS01)*	40—Needle Valve
6—Screw (2 used)	19—Ring	32—Washer (AS00, BS00 and AS01)*	41—Main Air Jet
7—Choke Shaft	20—Spring	33—Plug (AS00, BS00 and AS01)*	42—Pilot Air Jet
8—O-Ring	21—Seal	34—Spring	43—Main Air Jet (AS02)*
9—Pilot Jet-60	22—Carburetor Body	35—Drain Screw	44—Valve Seat (AS02)*
10—Plate	23—Clamp		45—Fuel Shutoff Solenoid (AS02)*
11—Screw	24—Hose		
12—Pilot Screw	25—Main Nozzle		
13—Spring	26—Bleed Pipe		

PA420A

* Engine Designation Number

MX,3020CL,6 -19-23OCT95

Carburetor/Remove and Install Carburetor

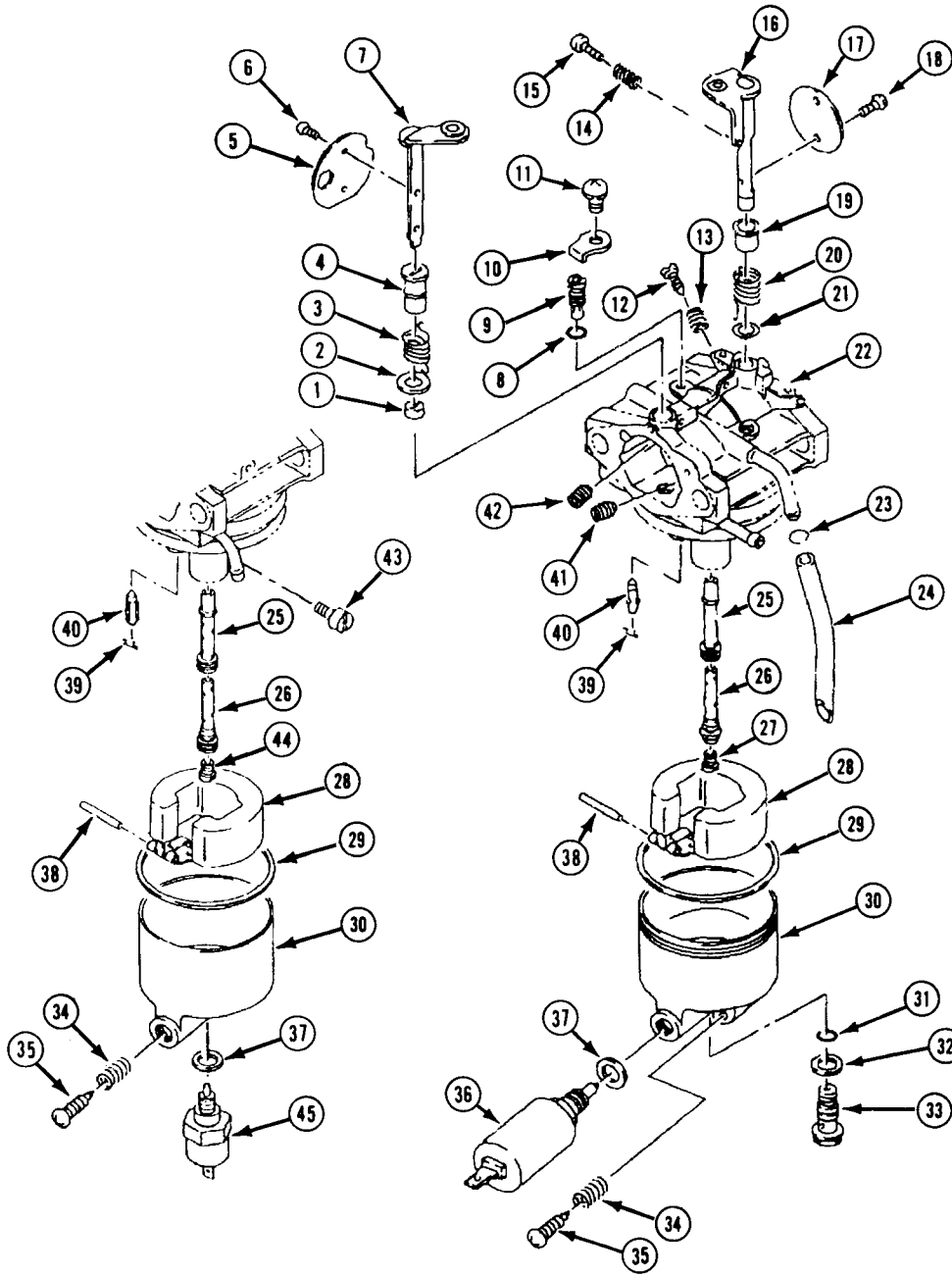

PA420A-AS02

PA420A-AS00, BS00 and AS01

MX,3020CL,6A -19-23OCT95

30
20

MB1623 -JUN-21/JUN95

DISASSEMBLE, CLEAN, INSPECT AND ASSEMBLE CARBURETOR—PA540A

1—Collar	14—Plate	27—Bleed Pipe	36—Drain Screw
2—Spring	15—Pilot Jet-75	28—Main Jet (AS00, BS00 and AS01)*	37—Fuel Shutoff Solenoid (AS00, BS00 and AS01)*
3—Collar	16—O-Ring	29—Float	38—Washer
4—Seal	17—Throttle Shaft	30—Gasket	39—Float Pin
5—Plate	18—Throttle Plate	31—Float Chamber	40—Clip
6—Choke Plate	19—Screw (2 used)	32—O-Ring (AS00, BS00 and AS01)*	41—Needle Valve
7—Screw (2 used)	20—Ring	33—Washer (AS00, BS00 and AS01)*	43—Main Air Jet
8—Choke Shaft	21—Spring	34—Plug (AS00, BS00 and AS01)*	43—Pilot Air Jet
9—Spring	22—Seal	35—Spring	44—Main Jet (AS02)*
10—Idle Screw	23—Carburetor Body		45—Valve Seat (AS02)*
11—Pilot Screw	24—Clamp		46—Fuel Shutoff Solenoid (AS02)*
12—Spring	25—Hose		
13—Screw	26—Main Nozzle		

PA540A

* Engine Designation Number

MX,3020CL,7 -19-23OCT95

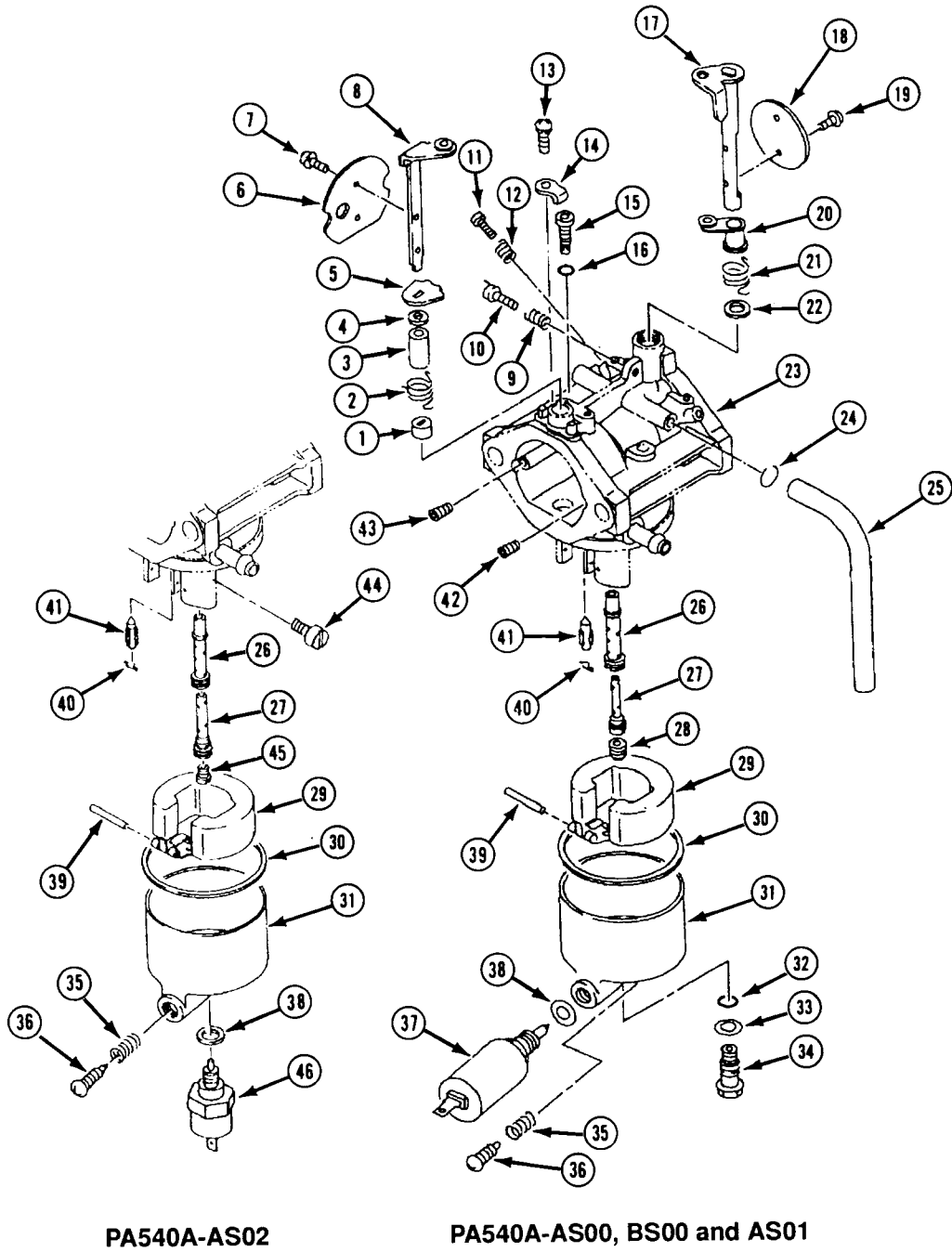

PA540A-AS02

PA540A-AS00, BS00 and AS01

MX,3020CL,7A -19-23OCT95

30
20
9

MB1624 -JUN-21-JUN95

ADJUST FLOAT

NOTE: PA540A engines with engine tag number BS00, pilot jet is pressed in.

IMPORTANT: To remove float, use a needle nosed pliers on end of pin. DO NOT strike opposite end of pin. Damage to pin holder may result.

DO NOT clean holes or passages with small drill bits or wire.

1. Soak carburetor body and all parts, except gaskets (discard), float and plastic rings, in carburetor cleaning solvent for 1/2 hour maximum.

2. Spray all passages with a carburetor cleaning spray to verify that all internal passages are open.

IMPORTANT: Rinse carburetor body in warm water to neutralize corrosive action of cleaner on aluminum.

3. Rinse carburetor with warm water and dry with compressed air. DO NOT use rags or paper to dry parts—lint may plug holes or passages.

4. Inspect all parts for wear or damage, replace as necessary.

NOTE: Main jet high altitude kits are available. For carburetors with black float, adjust float level. For carburetors with the white plastic float, float level CANNOT be adjusted. Replace if necessary.

30
20
10

MX,3020CL,8 -19-23OCT95

IMPORTANT: DO NOT push on float or nozzle jet when adjusting float level.

5. With carburetor upside down, float surface must be parallel (A) to carburetor body. Bend tang (B) to adjust float surface angle.

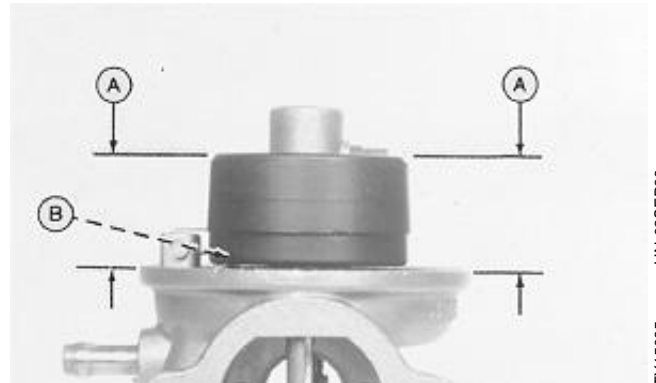

TY15085 -UN-02SEP88

MX,3020CL,9 -19-23OCT95

SERVICE BREATHER

NOTE: Breather valve assembly is located in cylinder heads of PA420A and PA540A engines.

1. Remove rocker arm cover.
2. Measure air gap between reed valve (A) and valve seat (B) at valve tip. Replace reed valve if gap exceeds **1—2 mm (0.040—0.080 in.)**.
3. Remove breather valve assembly (C).
4. Inspect breather for sticking, binding, cracks or distortion. Replace breather if worn or damaged.
5. Inspect valve seating surface. Surface must be free of nicks or burrs.
6. Install breather assembly.
7. Check that drain back hole in cylinder head and block is open.

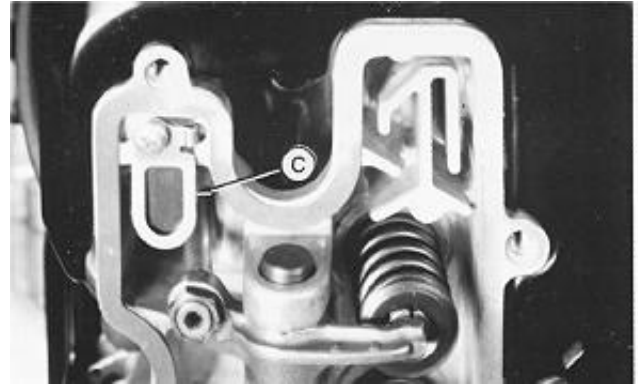
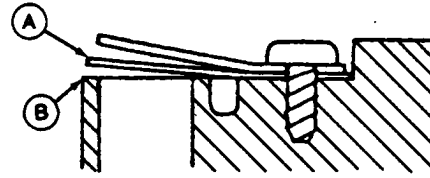

PA420A/PA540A

MX,2030CL,10 -19-23OCT95

M51757 -UN-07SEP88

M51757

M54486 -UN-09JAN91

M54486

30
20
11

30
20
12

Section 40 ELECTRICAL REPAIR

Contents

Page

Group 05—Electric PTO Clutch

Other Material	40-05-1
Remove/Install Electric PTO Clutch	40-05-2
Repair Warner PTO Clutch	40-05-3

Group 10—Starter

Other Materials	40-10-1
Service Parts Kits	40-10-1
Analyze Electric Starter Condition	40-10-1
Bench Test	
Solenoid Drive Starter	40-10-2
Solenoid	40-10-3
Test Electric Starter Armature Rotation	40-10-3
Inspect Electric Starter	
PA420A	40-10-4
PA540A	40-10-5
Test Armature	40-10-6
Test Field Coil and Brushes	40-10-7
Test Brush Holder	40-10-7

Group 15—Ignition and Charging System

Remove and Install	
Stator	40-15-1
Armature with Coil	40-15-1
Adjust Armature Air Gap	40-15-2

OTHER MATERIAL

Number	Name	Use
M79292	MPG-2 [®] Polymer Multipurpose Grease	Apply to engine crankshaft.

MPG-2[®] is a registered trademark of DuBois, a division of Chemed Corp.

MX,4005CL,A1A -19-23OCT95

40
05
1

REMOVE AND INSTALL ELECTRIC PTO CLUTCH

1. Remove drive belt.
2. Disconnect wire connector (A).
3. Remove cap screw and washer (B).
4. For Ogura clutch, remove clutch, spacer, and key from crankshaft. For Warner clutch, remove clutch, washer if equipped, and spacer.
5. Make repairs as necessary.
6. Apply MPG-2® Polymer Multipurpose Grease to crankshaft.

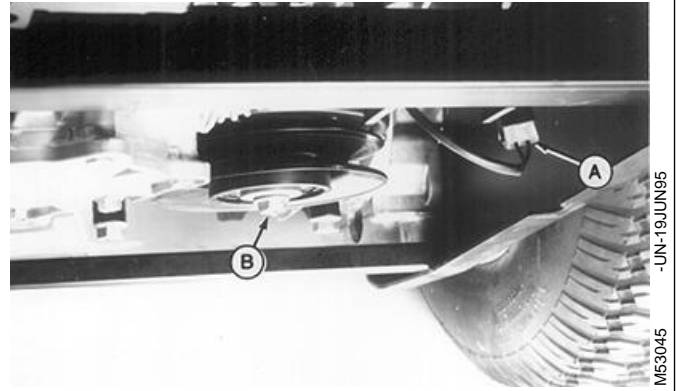

M53045
-UN-19JUN95

NOTE: *Inspect rubber damper in hole in crankcase.*

Make sure anti-rotation pin fits in rubber damper and clutch sit level to crankshaft.

7. For Ogura clutch, install spacer, PTO clutch and key on crankshaft. For Warner clutch, install spacer, washer if equipped, and PTO clutch on crankshaft.

IMPORTANT: Install washer with concave side toward PTO clutch.

8. Install cap screw and washer (B). Tighten cap screw to **56 N·m (45 lb-ft)** for Ogura clutch or **75 N·m (55 lb-ft)** for Warner clutch.
9. Connect wire connector (A).
10. Adjust PTO clutch (See PTO Clutch Adjustment in Section 240, Group 15).

MX,4005CL,A1 -19-23OCT95

40
05
2

DISASSEMBLE, INSPECT AND ASSEMBLE ELECTRIC PTO CLUTCH

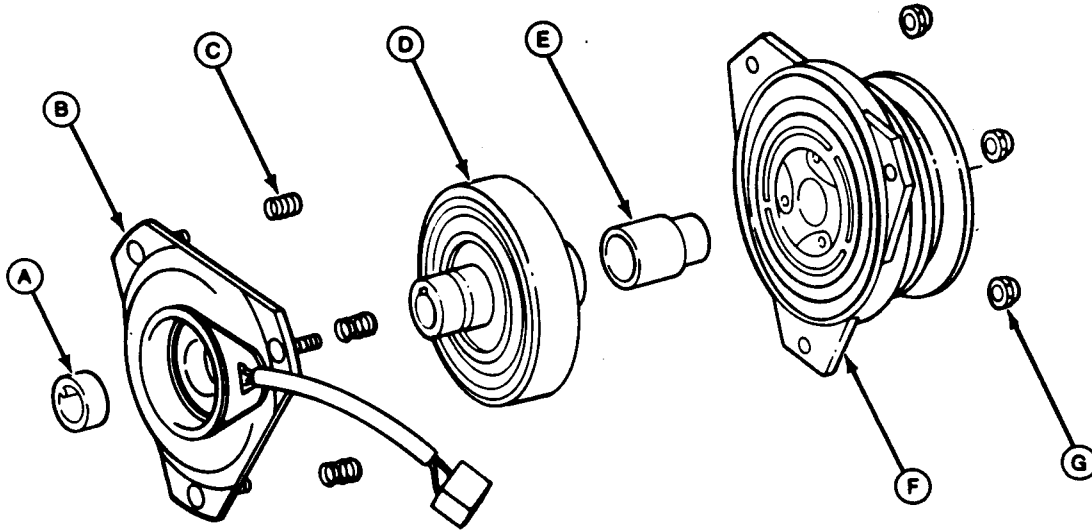

A—Spacer/Retainer
B—Electric Coil

C—Spring (3 used)
D—Rotor

E—Spacer
F—Armature

G—Lock Nut (3 used)

1. Remove nuts (G).
2. Remove parts (C, E and F).
3. Press rotor (D) from parts (A and B).

NOTE: PTO clutch is serviced as an assembly. If components other than parts (C and G) are damaged, the entire PTO clutch must be replaced.

Key inside rotor (D) is a machined feature of rotor, not a separate component.

4. Inspect parts (A—G) for wear or damage. Check operation of bearings in parts (B and F). Replace clutch if necessary.

NOTE: Install, but DO NOT tighten lock nuts (G).

5. Assemble parts (A—G).
6. Install PTO clutch. (See Remove and Install Electric PTO Clutch in this group.)
7. Adjust PTO clutch. (See PTO Clutch Adjustment in Section 240, Group 15.)

MX,4010FS,A3 -19-23OCT95

M54649 JUN-27SEP90

40-05-3

40
05
4

OTHER MATERIAL

Number	Name	Use
	Mineral Spirits	Clean Armature
	Multipurpose Grease	Grease Starter Parts

M98,2030A,ZB -19-21OCT92

SERVICE PARTS KITS

The following kits are available through your parts catalog:

Electric Starter:

- Brush Kit
- Clutch Kit
- Complete Starter
- Complete Solenoid—PA420A and PA540A

MX,4010CL,1 -19-23OCT95

ANALYZE ELECTRIC STARTER CONDITION

1. The starter overheats because of:

- Long cranking.
- Armature binding.

2. The starter operates poorly because of:

- Armature binding.
- Dirty or damaged starter drive.
- Badly worn brushes or weak brush springs.
- Excessive voltage drop in cranking system.
- Battery or wiring defective.
- Shorts, opens, or grounds in armature.

NOTE: Starter repair is limited to brushes, end caps, and starter drive. Fields in starter are permanent magnets and are not serviceable. If housing or armature is damaged, replace starter.

MX,4010CL,A6 -19-23OCT95

40
10
1

BENCH TEST SOLENOID DRIVE STARTER

NOTE: Perform bench test before disassembling starter motor to determine cause of problem.

IMPORTANT: Never operate motor longer than 20 seconds. Allow at least two minutes for cooling and battery recovery before operating again. Overheating, caused by excessive operation, will seriously damage starting motor.

1. Disconnect battery leads from battery, negative (—) lead first.
2. Remove starter from engine.
3. Connect 12-volt battery (A) to starter battery terminal (B) and starter frame (C) using heavy duty cables.
4. Connect remote start switch (D) between switch terminal (E) and battery terminal (B).

NOTE: A short piece of wire with a small alligator clip on the ends will allow a more positive connection at the switch terminal.

5. Activate remote start switch, starter should engage and run.

IF SOLENOID CHATTERS; hold-in winding is open-circuited.

IF NOTHING HAPPENS; either the solenoid pull-in winding is open-circuited or mechanical parts are sticking.

IF SOLENOID ENGAGES, BUT MOTOR DOES NOT RUN; check solenoid switch continuity, brushes, armature and field windings.

NOTE: Solenoid cannot be repaired, if faulty it must be replaced.

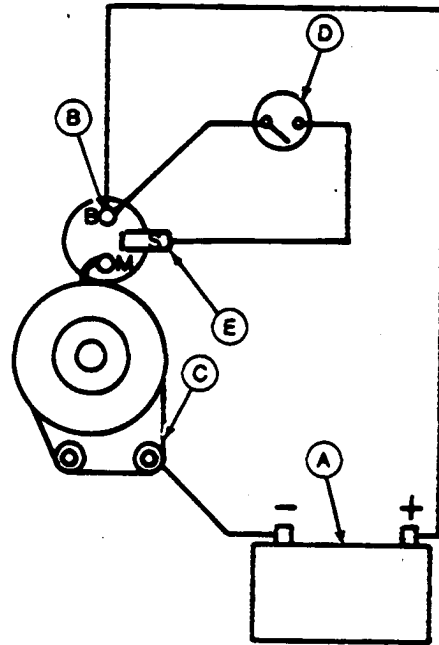

A—12-Volt Battery
 B—Battery Terminal
 C—Starter Frame
 D—Remote Start Switch
 E—Switch Terminal

40
10
2

-JUN-29AUG88

M37149

MX,4010CL,A7 -19-23OCT95

SOLENOID TEST

NOTE: If bench test indicated solenoid problems, use an ohmmeter or test light to check solenoid.

1. Test solenoid terminals (A and B) for continuity. There should be **NO CONTINUITY**.
2. Depress switch arm (C). There **SHOULD BE CONTINUITY** when arm is fully depressed.
3. Test for open circuits between terminal (B) and tang (D). There **SHOULD BE CONTINUITY**.
4. Test for open circuits between tang (D) and body (E). There **SHOULD BE CONTINUITY**.
5. If solenoid fails any test, it is defective and **MUST BE REPLACED**.

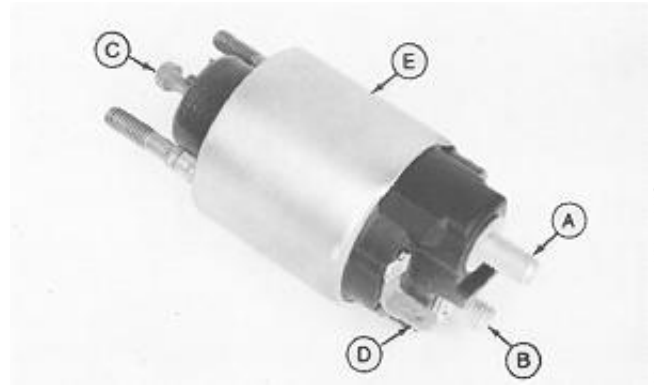

A—Terminal
B—Terminal
C—Switch Arm
D—Tang
E—Solenoid Body

M51705 -UN-31AUG88

40
10
3

MX,4010CL,A8 -19-23OCT95

CHECK STARTER ARMATURE ROTATION

1. Remove starter.
2. Rotate armature (A).

IF ARMATURE DOES NOT ROTATE FREELY; armature may be bent or bearings may be worn. Disassemble, inspect and clean starter. (See procedures in this group.)



PA420A/PA540A

M53972 -UN-18APR90

MX,4010CL,A9 -19-23OCT95

INSPECT STARTER—PA420A/PA540A-AS02

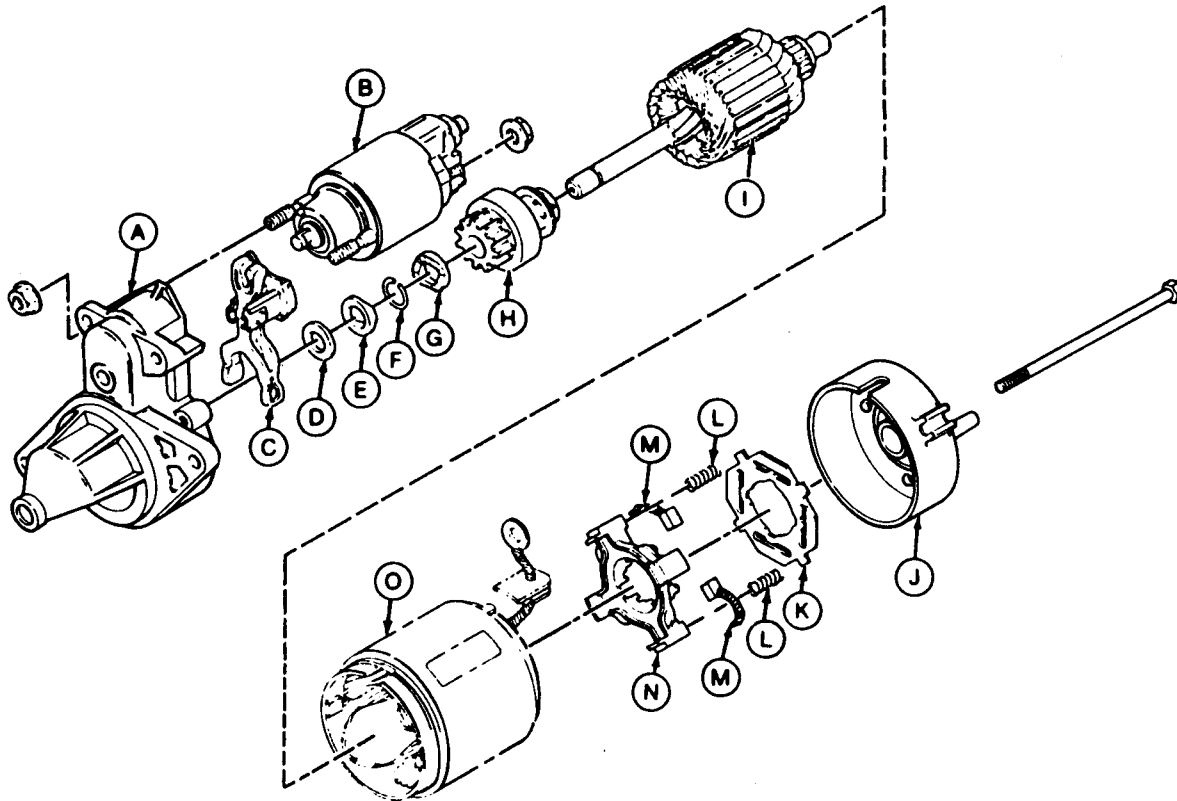

A—Front Cover
B—Solenoid
C—Shift Lever
D—Washer

E—Pinion Stopper Half
F—Retaining Clip
G—Pinion Stopper Half
H—Pinion

I—Armature
J—End Cover
K—Insulator
L—Brush Spring

M—Brush
N—Brush Holder
O—Body

1. Before disassembly, mark body and covers for correct alignment during reassembly.
2. Separate pinion stopper halves (E and G) to remove retaining clip (F).
3. Inspect parts for wear or damage.
4. Measure brushes (M). Replace brushes as a set if length of any one is less than **6 mm (0.240 in.)**.

5. Test starter armature and brushes. (See procedures in this group.)
6. Apply a thin coat of multipurpose grease to:
 - sliding surfaces of armature and solenoid shift lever.
 - armature shaft spline.
 - points where shaft contacts cover.
7. Assemble starter, using alignment marks.

MX,4010CL,A11 -19-23OCT95

INSPECT STARTER—PA540A-AS00, BS00 AND AS01

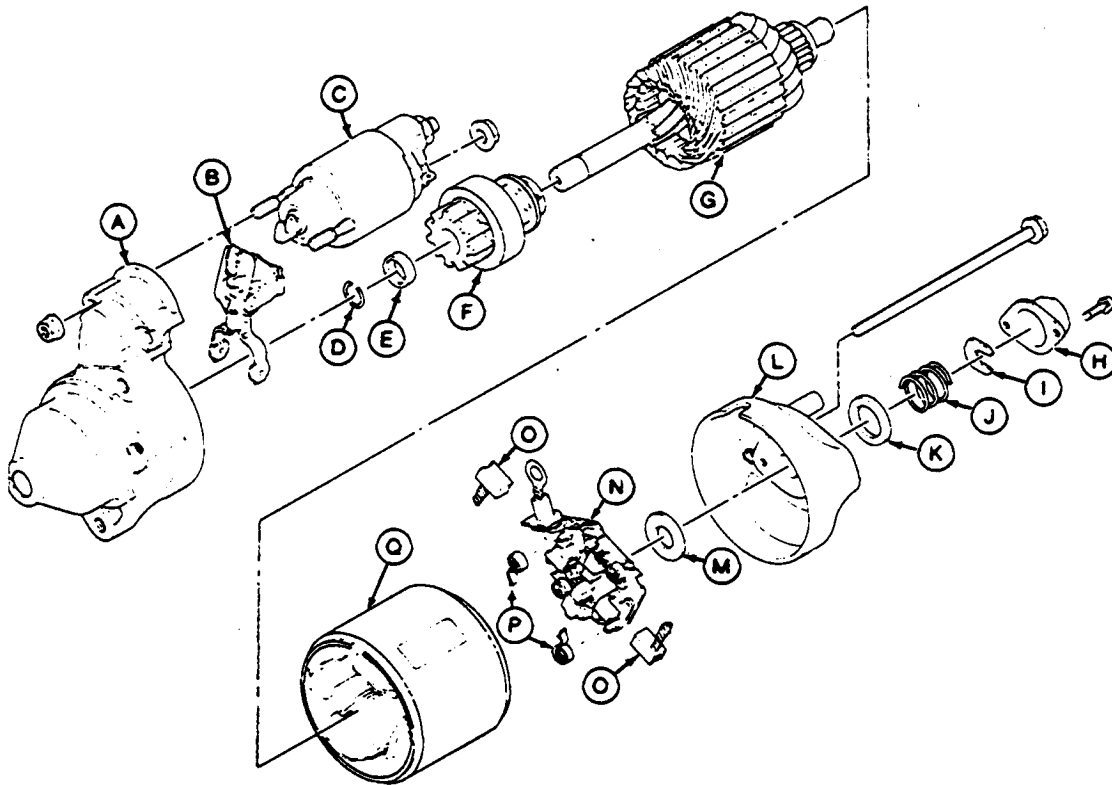

A—Front Cover
 B—Shift Lever
 C—Solenoid
 D—Retaining Clip
 E—Pinion Stopper

F—Pinion
 G—Armature
 H—Dust Cap
 I—Clip

J—Spring
 K—Washer
 L—End Cover
 M—Washer

N—Brush Holder
 O—Brush
 P—Brush Spring
 Q—Body

1. Before disassembly, mark body and covers for correct alignment during reassembly.
2. Push pinion stopper (E) toward pinion (F) to remove retaining clip (D).
3. Inspect parts for wear or damage.
4. Measure brushes (O). Replace brushes as a set if length of any one is less than **10.5 mm (0.413 in.)**.

5. Test starter armature and brushes. (See procedures in this group.)
6. Apply a thin coat of multipurpose grease to:
 - sliding surfaces of armature and solenoid shift lever.
 - armature shaft spline.
 - points where shaft contacts cover.
7. Assemble starter, using alignment marks.

M50120 -JUN-31AUG88

40
10

TEST STARTER ARMATURE

IMPORTANT: DO NOT clean armature with solvent. Solvent can damage insulation on windings. Use only mineral spirits and a brush.

1. Locate short circuits by rotating armature on a growler while holding a hacksaw blade or steel strip on armature. The hacksaw blade will vibrate in area of short circuit.

2. Shorts between bars are sometimes caused by dirt or copper between bars. Inspect for this condition.

IF TEST INDICATES SHORT CIRCUITED WINDINGS; clean the commutator of dust and fillings. Check armature again.

IF TEST STILL INDICATES SHORT CIRCUIT; replace armature.

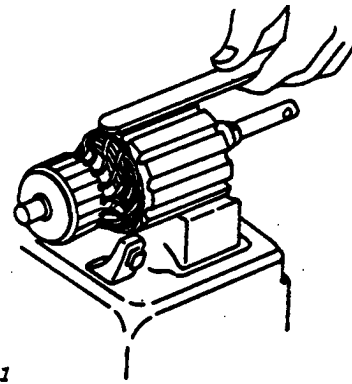

M24861

M24861 -UN-25AUG88

40
10
6

M98,2030A,K -19-23OCT95

3. Test for grounded windings using an ohmmeter or test light.

NOTE: Armature windings are connected in parallel, so each commutator bar needs to be checked.

IF TEST SHOWS CONTINUITY; a winding is grounded and the armature **must be replaced**.

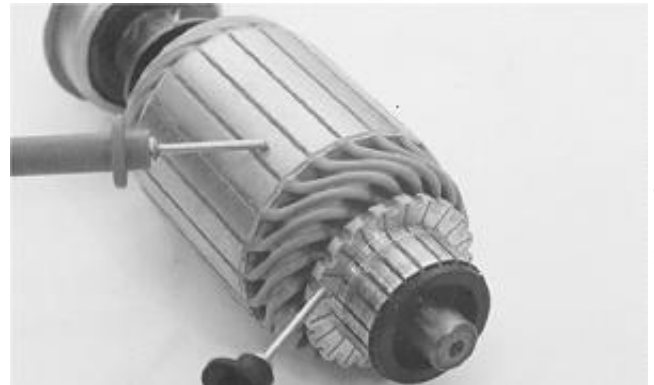

M98,2030A,AH -19-23OCT95

M50112 -UN-31AUG88

4. Test for open circuited windings using an ohmmeter or test light.

IF TEST SHOWS NO CONTINUITY; there is an open circuit and armature **must be replaced**.



M98,2030A,M -19-23OCT95

M50113 -UN-31AUG88

TEST FIELD COIL AND BRUSHES

1. Check for open or grounded coils and brushes using an ohmmeter.
2. Replace field coil if not according to specifications.
3. Coil frame is the tie point for the separate field coils. It may be difficult to detect one bad coil.

IF RPM WAS SLOW AND ARMATURE TESTS ARE NORMAL; replace field coil assembly.

CONTINUITY TEST

- Negative Brush to Negative Brush (A) Continuity
- Negative Brush (A) to Housing (B) Continuity
- Positive Brush to Positive Brush (C) Continuity
- Positive Brush (C) to Housing (B) No Continuity

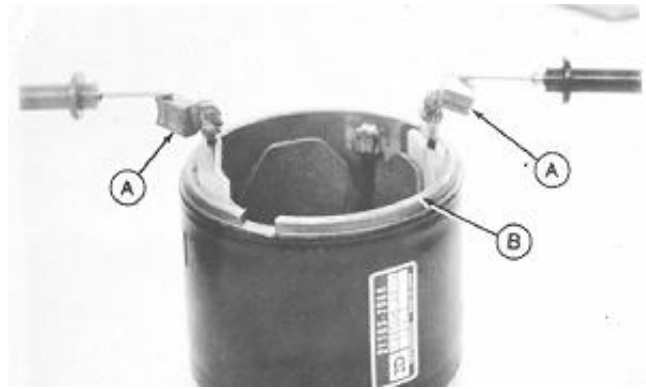

PA540A



PA420A/PA540A-AS02

MX,4010CL,A13 -19-23OCT95

-UN-22APR92
M46176

40
10
7
-UN-22APR92

M46177

TEST BRUSH HOLDER

1. Check for open or grounded brushes using an ohmmeter.
2. Replace brush holder if not according to specifications.

CONTINUITY TEST

- Positive Brush to Positive Brush (A) Continuity
- Negative Brush (B) to Brush Plate (C) No Continuity

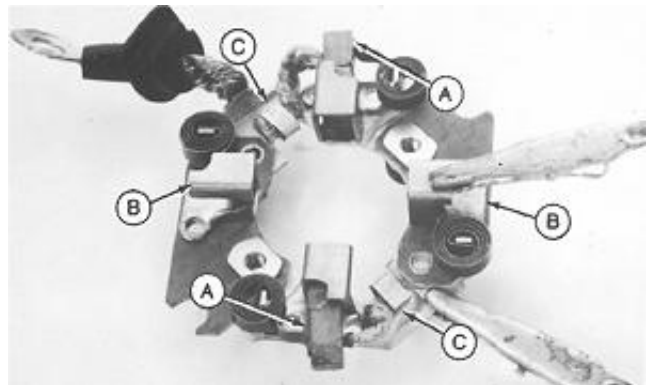

PA540A-AS00, BS00 and AS01

MX,4010CL,A14 -19-23OCT95

-UN-22APR92

M46178

REMOVE AND INSTALL STATOR

1. Remove flywheel. (See Remove and Install Flywheel in Section 20, Group 10.)
2. Loosen baffle (A). Disconnect stator lead (B).
3. Remove screws and stator (C).
4. Install stator.
5. Connect stator lead.
6. Install flywheel. (See Remove and Install Flywheel in Section 20, Group 10.)



M53048 -UN-13APR89

MX,4015CL,A1 -19-23OCT95

REMOVE AND INSTALL ARMATURE WITH COIL

1. Remove blower housing. (See Remove and Install Blower Housing in Section 20, Group 10.)
2. Disconnect wiring lead (A).
3. Remove cap screws (B) and armature with coil (C).
4. Loosely install armature with coil.
5. Connect wiring lead.
6. Adjust armature air gap. (See Adjust Armature Air Gap in this group.)
7. Install blower housing. (See Remove and Install Blower Housing in Section 20, Group 10.)

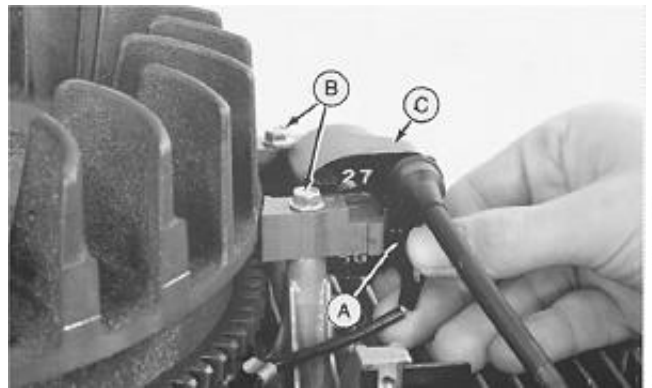

M50147 -UN-23FEB89

MX,4015CL,A2 -19-23OCT95

ADJUST ARMATURE AIR GAP

1. Turn flywheel magnet away from armature.
2. Insert **0.30 mm (0.012 in.)** feeler gauge, between flywheel and armature.
3. Push armature against flywheel and tighten screws (A) to **3 N·m (30 lb-in.)**.
4. Turn flywheel to remove feeler gauge.

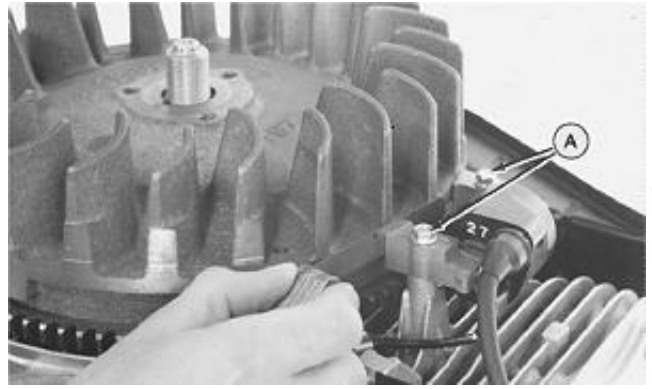

MX,4015CL,A3 -19-23OCT95

M50148 -UN-31AUG88

Section 50 POWER TRAIN REPAIR

Contents

Page

Group 10—Hydrostatic Transmission and Differential

Engine Configuration Chart	50-10-1
Variable Displacement Pump	
Disassemble	50-10-2
Inspect Oil Screen	50-10-3
Inspect Charge Pump	50-10-4
Inspect Pump Shaft Bearing	50-10-5
Assemble Variable Displacement Pump . .	50-10-6
Disassemble/Inspect Charge Relief & Anti-Cavitation Valves	50-10-8
Assemble Charge Relief Valves	50-10-9
Remove and Disassemble Swash Plate . .	50-10-9
Inspect Swash Plate Assembly	50-10-10
Inspect Pump Drive Shaft Assembly	50-10-11
Inspect Pump Cylinder—Assembly	50-10-12
Inspect Control Lever Shaft	50-10-12
Assemble Swash Plate	50-10-13
Remove and Install Axle Assemblies	50-10-14
Inspect Axle Assembly	50-10-14
Disassemble Reduction Gear Assembly . .	50-10-15
Inspect Rotating Group	50-10-17
Assemble Rotating Group	50-10-18
Disassemble Fixed Displacement Motor . .	50-10-19
Inspect Fixed Displacement Motor	
Housing	50-10-20
Inspect Input Shaft Assembly	50-10-21
Inspect Motor Cylinder Assembly	50-10-22
Inspect Axle Housing	50-10-23
Assemble Fixed Displacement Motor	50-10-24
Disassemble and Assemble	
Free-Wheeling Valve	50-10-26
Inspect Free-Wheeling Valve	50-10-26
Disassemble Differential	50-10-26
Inspect Differential	50-10-27
Assemble Differential	50-10-29
Inspect Directional Pedals	50-10-30

50

ENGINE CONFIGURATION CHART

The PA420A and PA540A engines have an engine configuration number following the engine model number to help separate engine changes. Use the engine configuration number to determine the proper service specifications and procedures to follow in this technical manual.

ENGINE CONFIGURATION CHART

F510 (Engine S.N. -3887)	PA420A-AS00
(Engine S.N. 3888-4898)	PA420A-BS00
(Engine S.N. 4899-7322)	PA420A-AS01
(Engine S.N. 7323-)	PA420A-AS02
F525 (Engine S.N. -7891)	PA540A-AS00
(Engine S.N. 7892-11999)	PA540A-BS00
(Engine S.N. 12000-21944)	PA540A-AS01
(Engine S.N. 21945-)	PA540A-AS02

MX,1015CL,1 -19-23OCT95

REMOVE AND INSTALL HYDROSTATIC TRANSMISSION AND DIFFERENTIAL

See Remove Engine and Install Engine in Section 20, Group 05.

NOTE: It is not necessary to remove engine/transaxle to service variable displacement pump.

MX,5010CL,A1A -19-23OCT95

50
10
1

DISASSEMBLE VARIABLE DISPLACEMENT PUMP

NOTE: Removal of crankcase is not required to disassemble variable displacement pump or hydrostatic transaxle. Crankcase is shown removed in this section only for clarity.

NOTE: Variable Displacement pump can be serviced while installed in front mower. If service is to be performed while the hydrostatic transaxle is installed in the front mower, remove the drain plug from the crankcase and drain oil before beginning procedure. Some oil will remain in the hydrostatic transmission after the crankcase has been drained.

1. Remove oil lines (A) and for PA420A/PA540A-AS00 and BS00, remove oil line (B). Oil line (B) has been replaced with an internal oil passage for PA420A/PA540A-AS01 and AS02 engines.

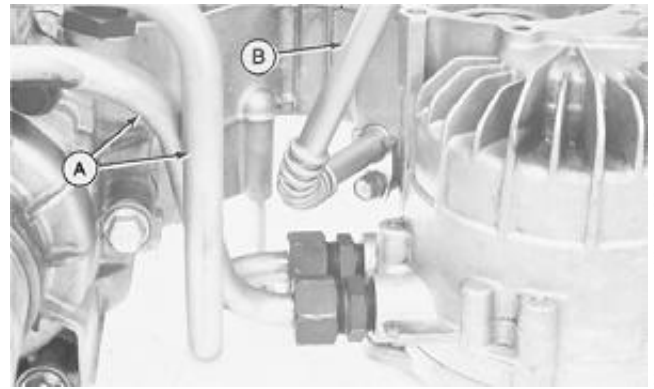

M53011 -UN-05APR89

MX,5010CL,A35 -19-23OCT95

2. Remove cover (A) before removing charge pump housing (B).
3. Remove plate (C).
4. Remove inner (D) and outer (E) rotors.

A—Pump Cover
 B—Charge Pump Housing
 C—Pump Plate
 D—Inner Rotor
 E—Outer Rotor

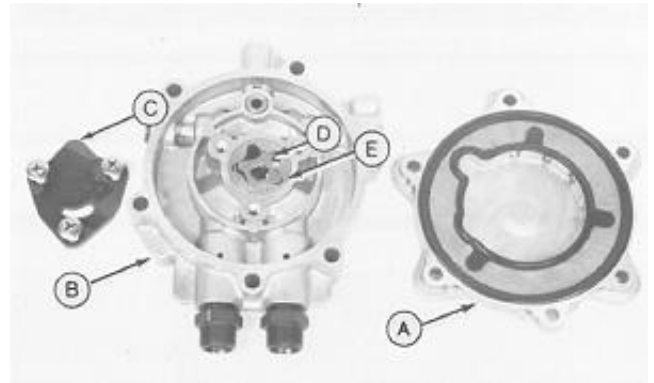

PA420A/PA540A-AS00 and BS00

M53012 -UN-05APR89

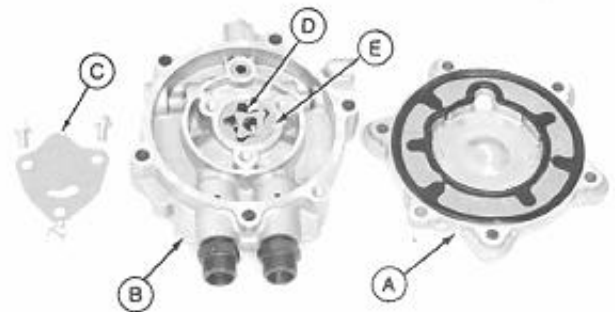

PA420A/PA540A-AS01

M46179 -UN-22APR92

MX,5010CL,A36 -19-23OCT95

IMPORTANT: Remove cylinder assembly (B) carefully so pistons do not fall from the cylinder bores.

5. Push cylinder assembly (B) inward to compress spring (C) and remove circlip (A).
6. Remove spring (C).
7. Remove O-ring (D).
8. For PA420A/PA540A-AS01 and AS02, remove O-ring (E).

A—Circlip
B—Cylinder Assembly
C—Cylinder Spring
D—O-Ring
E—O-Ring

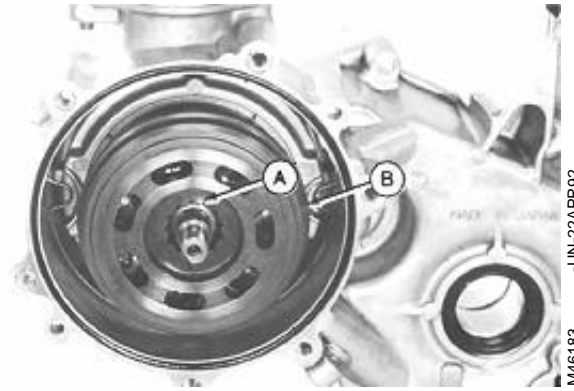

M46183
-UN-22APR92



M46184
-UN-22APR92

MX,5010CL,A37 -19-23OCT95

INSPECT OIL SCREEN

1. Remove screen (A) and clean in solvent.
2. Check screen and replace if damaged or if sealing surface (B) is cracked, dented or hardened.

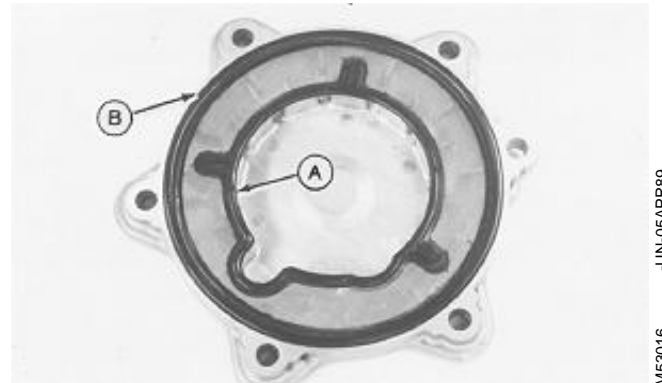

M53016
-UN-05APR89

MX,5010CL,A40 -19-23OCT95

INSPECT CHARGE PUMP

1. Inspect inner (A) and outer (B) rotors and pump housing for wear or damage.
2. Measure outside diameter of outer rotor.
3. Measure thickness of outer rotor.

NOTE: Replace rotors as a set if not within specifications.

4. Measure inside diameter (C) of pump housing.
5. Measure depth of pump housing.

Replace housing if not within specifications.

SPECIFICATIONS

Outer Rotor O.D. (Minimum)	40.45 mm (1.593 in.)
Outer Rotor Thickness (Minimum)	12.95 mm (0.510 in.)
Pump Housing I.D. (Maximum)	40.80 mm (1.606 in.)
Pump Housing Depth (MAX)	13.15 mm (0.518 in.)

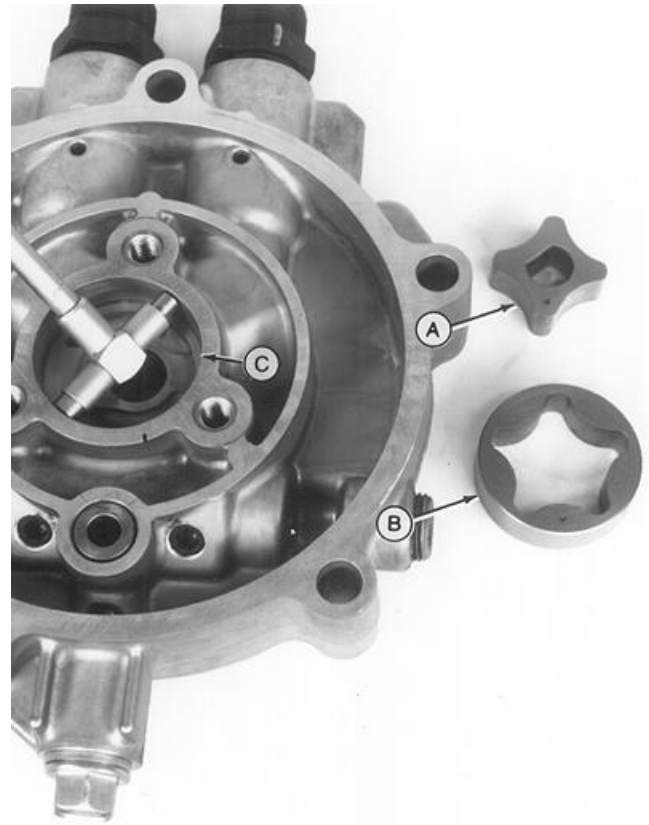

M53014 -UN-19JUN95

MX,5010CL,A38 -19-23OCT95

50
10
4

INSPECT PUMP SHAFT BEARING

IMPORTANT: Dry parts with compressed air. Lint from cloth rags can damage transmission.

1. Clean bearing (A) in solvent and dry with compressed air **while keeping the bearing from spinning**.
2. Coat bearing with light weight oil and check for smooth operation.

CAUTION: DO NOT heat oil over 182°C (360°F). Oil fumes or oil can ignite above 193°C (380°F). Use a thermometer. Do not allow a flame or heating element to come in direct contact with the oil. Heat the oil in a well-ventilated area. Plan a safe handling procedure to avoid burns.

3. To replace bearing, remove snap ring (B) and heat pump housing in an oil bath at 165°C (327°F). Remove bearing using a slide hammer.
4. Place housing on surface plate, snap ring side up, to press bearing in.
5. Install snap ring.

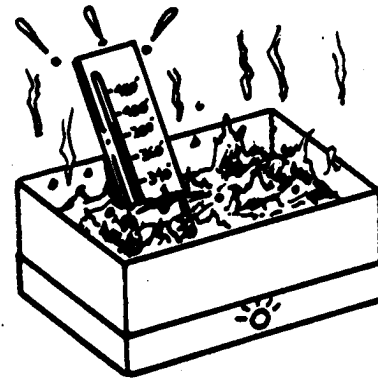
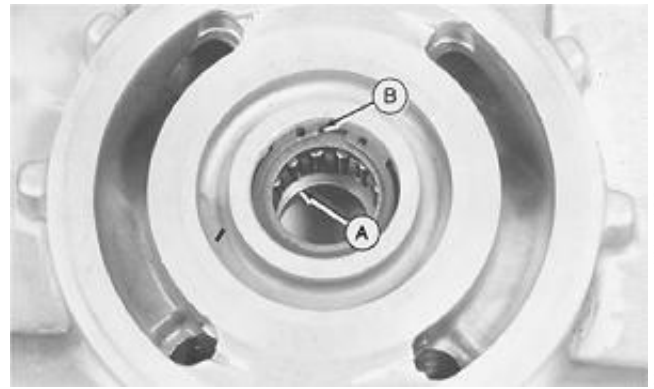

M53015 -UN-05APR89

-UN-23FEB89

T81191

50
10

MX,5010CL,A39 -19-23OCT95

ASSEMBLE VARIABLE DISPLACEMENT PUMP

1. For PA420A/PA540A-AS01 and AS02, install O-ring (E).
2. Install O-ring (D).
3. Install spring (C).

IMPORTANT: When installing cylinder assembly, hold pistons to prevent them from falling from pump housing. Damage to pistons may result.

4. Install cylinder assembly (B) and circlip (A).

A—Circlip
B—Cylinder Assembly
C—Cylinder Spring
D—O-Ring
E—O-Ring

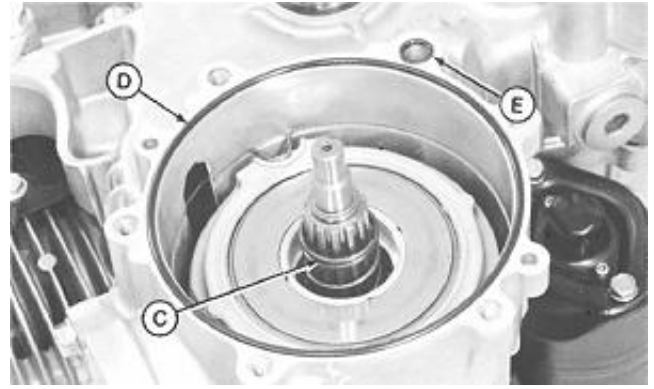

M46184
-UN-22APR92

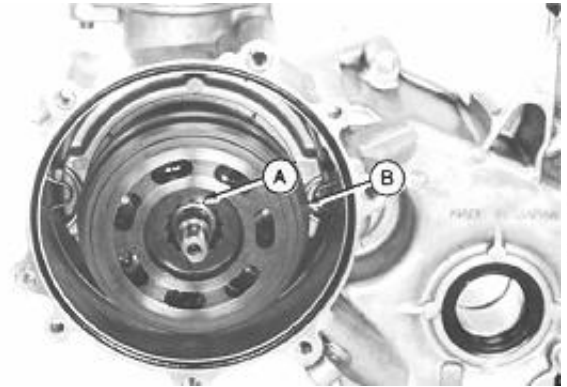

M46183
-UN-22APR92

MX,5010CL,A41 -19-23OCT95

5. Install charge pump housing (B).
6. Install outer (E) and inner (D) rotors with rotor dots (F) towards cover.
7. Install plate (C).
8. Install cover (A). Tighten in sequence shown to initial torque of **18 N·m (159 lb-in.)**. The continue in sequence in **3 N·m (26.6 lb-in.)** increments to final torque specifications.

SPECIFICATIONS

Final Cover Torque 25.5 N·m (225 lb-in.)
 Short Cap Screw Torque 20 N·m (177 lb-in.)

- A—Pump Cover
- B—Charge Pump Housing
- C—Pump Plate
- D—Inner Rotor
- E—Outer Rotor
- F—Rotor Dots

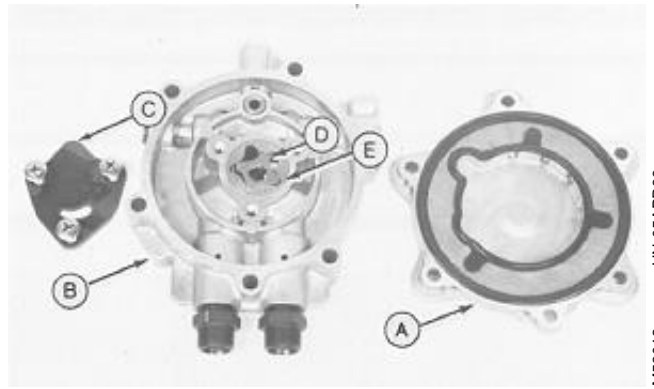

PA420A/PA540A-AS00 and BS00

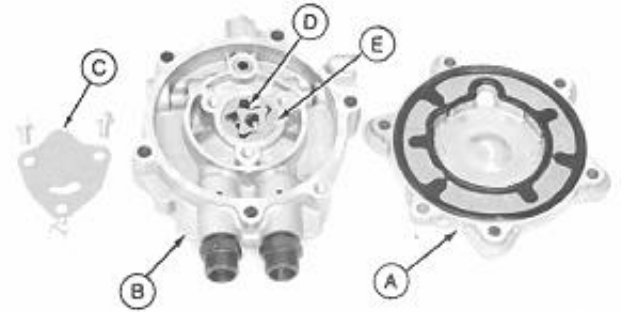

PA420A/PA540A-AS01 and AS02

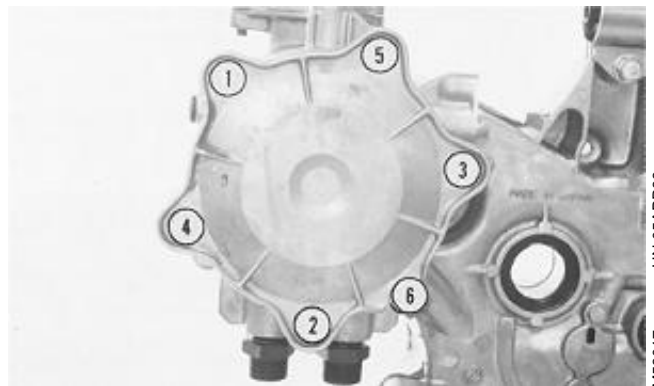
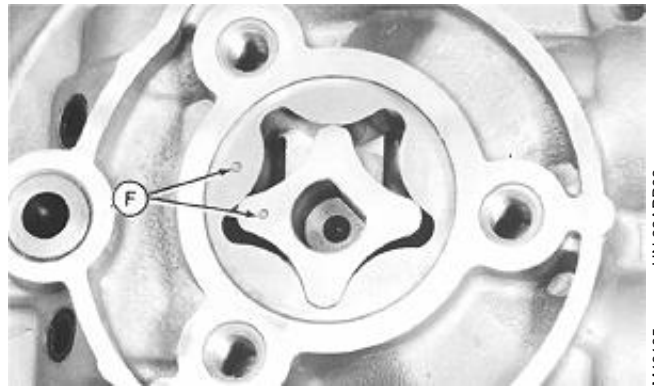

M53012 -UN-05APR89

-UN-22APR92

M46179

-UN-22APR92

M46185

-UN-05APR89

M53017

9. Install oil lines (A) and for PA420A/PA540A-AS00 and BS00, install oil line (B). Tighten to specifications.

SPECIFICATIONS

Oil Lines (A) Nut 79 N·m (58 lb-ft)
 Oil Line (B) Cap Screw 20 N·m (177 lb-in.)

Early Model Shown

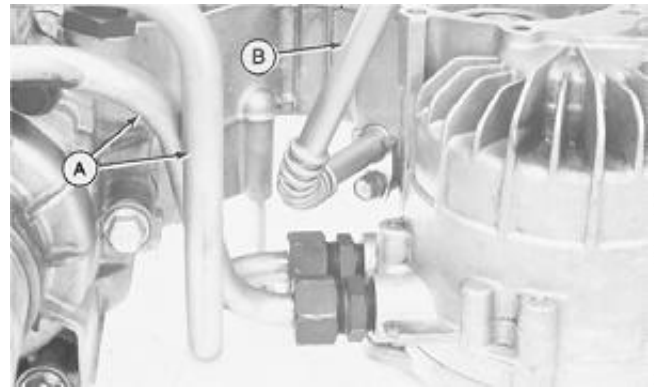

M53011
-UN-05APR89

MX,5010CL,A43 -19-23OCT95

DISASSEMBLE AND INSPECT CHARGE RELIEF AND ANTI-CAVITATION VALVES

IMPORTANT: Dry parts with compressed air. Lint from cloth rags can damage transmission.

1. Clean housing in solvent and dry with compressed air.
2. Remove relief valve plug (E), gasket (J), spring (I) and ball (H). Replace damaged parts. Replace spring if free length is **less than 32 mm (1.26 in.)**.

IMPORTANT: Check valve screws (A) and plug(s) (D) are secured with thread locking compound. Used caution when removing to prevent damage to housing.

3. Remove plug(s) (D).
4. Remove check valve screws (A), springs (F) and balls (G). Replace damaged parts. Replace spring if free length is **less than 14 mm (0.55 in.)**.
5. Shake housing. Remove valve seat (C) if ball (B) does not rattle.

NOTE: Replace valve seat and ball as a set.

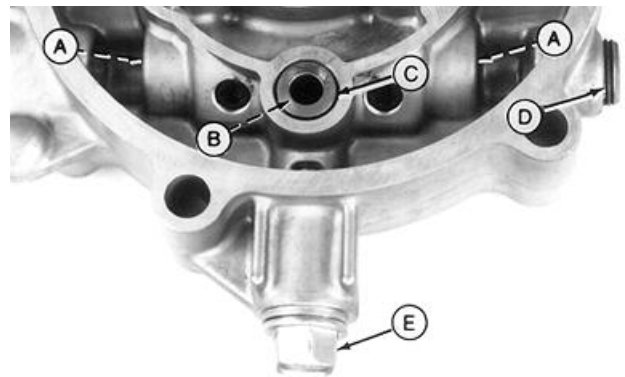

M53018
-UN-23JUN95

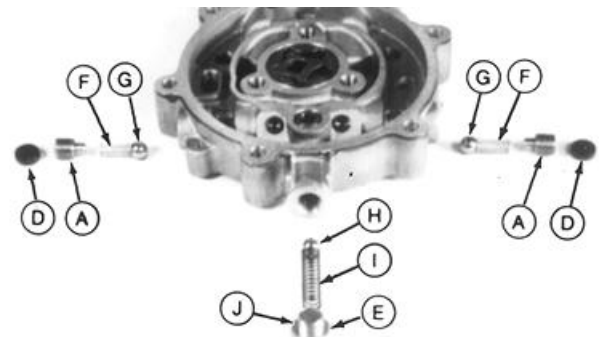

M53095
-UN-23JUN95

- A—Check Valve Screws
- B—Check Valve Ball
- C—Anti-Cavitation Valve Seat
- D—Plug (2 used for PA420A/PA540A-AS01 and AS02)
- E—Charge Relief Valve Plug
- F—Spring
- G—Anti-Cavitation Ball (2 used)
- H—Relief Valve Ball (2 used)
- I—Spring
- J—Gasket

MX,5010CL,A44 -19-23OCT95

ASSEMBLE CHARGE RELIEF VALVES

1. Install balls (G) and (H). Balls may be tapped onto their seats to promote proper seal.
2. Install springs (F) and (I).
3. Install cap screws (A) and charge relief valve plug (E). Tighten to **20 N·m (177 lb-in.)**.
4. If removed, install ball (B) and press in valve seat (C) flush with housing.
5. Install plugs (D). Tighten to **20 N·m (177 lb-in.)**.

- A—Allen Head Cap Screws
- B—Check Valve Ball
- C—Anti-Cavitation Valve Seat
- D—Plug (2 used for PA420A/PA540A-AS01 and AS02)
- E—Charge Relief Valve Plug
- F—Spring
- G—Anti-Cavitation Ball (2 used)
- H—Relief Valve Ball (2 used)
- I—Spring
- J—Gasket

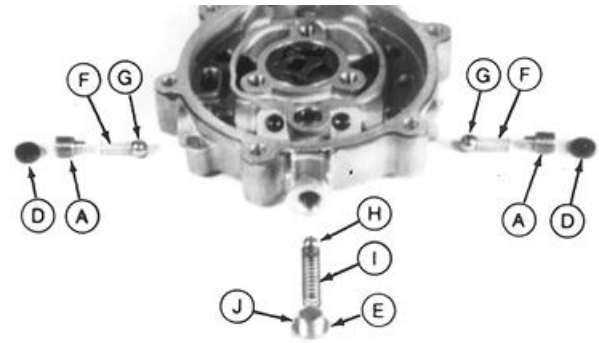
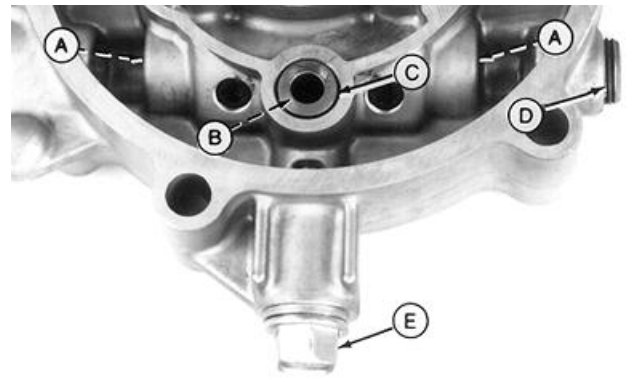

MX,5010CL,A45 -19-23OCT95

-JUN-23JUN95

M53018

-JUN-23JUN95

M53095

50
10

REMOVE AND DISASSEMBLE SWASH PLATE

1. Remove variable displacement pump (See Disassemble Variable Displacement Pump in this group.)
2. Remove control shaft assembly (A).
3. Remove snap ring (B).
4. Remove swash plate (C).

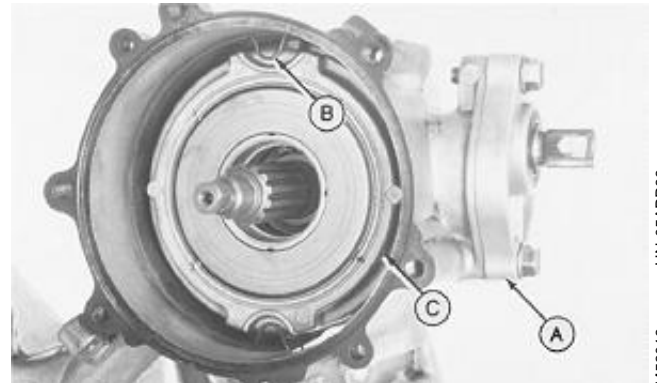

MX,5010CL,A46 -19-23OCT95

-JUN-05APR99

M53019

5. Remove balls (B) and wear cups (C).
6. Remove snap ring (D).
7. Remove pump drive shaft assembly (A).

- A—Pump Drive Shaft
- B—Balls
- C—Wear Cups
- D—Snap Ring

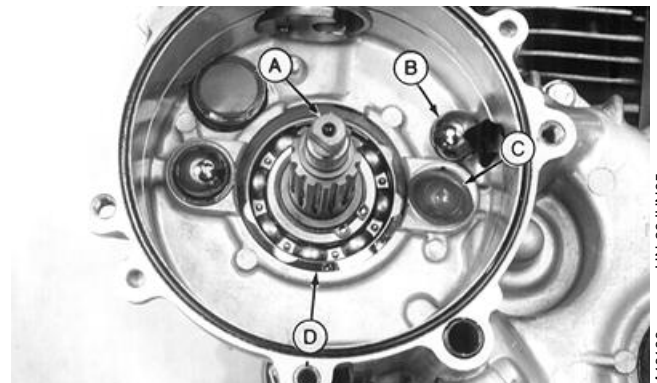

MX,5010CL,A47 -19-23OCT95

-JUN-23JUN95

M46186

INSPECT SWASH PLATE ASSEMBLY

IMPORTANT: Dry parts with compressed air. Lint from cloth rags can damage pump.

1. Clean swash plate assembly with solvent and dry with compressed air.
2. Lubricate needle bearing (A) with light weight oil and check for smooth operation.
3. For PA420A/PA540A-AS01 and AS02, remove cap screws (D) to remove needle bearing (A).
4. Check balls and ball seats (B) for scoring or wear.

NOTE: Pin (C) can not be removed without damaging swash plate assembly. If pin must be replaced, a new swash plate must also be used.

5. Check pin (C) for wear or damage.
6. Tighten cap screws (D) to **1.6 N-m (12 lb-in.)**. Be sure bearing turns freely after tightening cap screws.



PA420A/PA540A-AS00 and BS00

M53021 -UN-05APR89

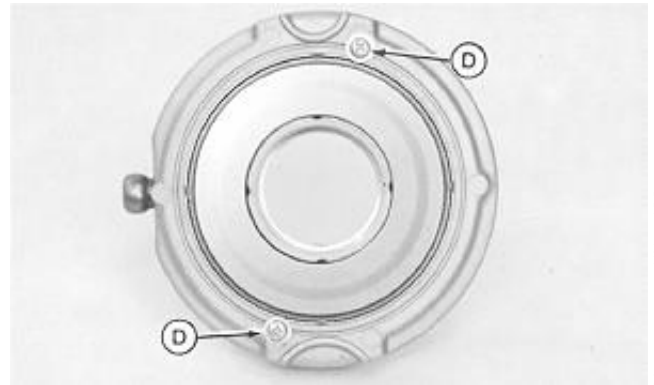

PA420A/PA540A-AS01 and AS02

M46180 -UN-22APR92



M53022 -UN-28APR89

MX,5010CL,A48 -19-23OCT95

50
10
10

INSPECT PUMP DRIVE SHAFT ASSEMBLY

IMPORTANT: Dry parts with compressed air. Lint from cloth rags can damage pump.

CAUTION: DO NOT allow compressed air to spin dry ball bearing. Bearing can shatter causing injury.

1. Clean bearing (C) and dry with compressed air, **while keeping bearing from spinning.**
2. Coat bearing with light weight oil and check for smooth operation.
3. Check for axial (A) and radial (B) play. If rough operation or excessive play is noted, remove snap ring (D) and replace bearing using a bearing driver.
4. Inspect gear teeth and spline for nicks and improper tooth contact.
5. Measure outside diameter of journal (E). Replace shaft if damaged or if journal O.D. is **less than 11.90 mm (0.46 in.)**.

A—Axial Play Distance
B—Radial Play Distance
C—Drive Shaft Bearing
D—Snap Ring
E—Drive shaft Journal

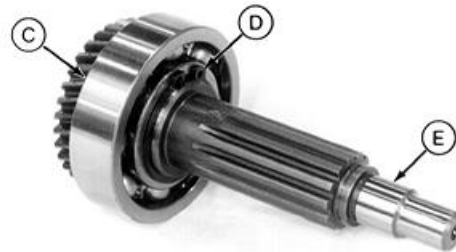
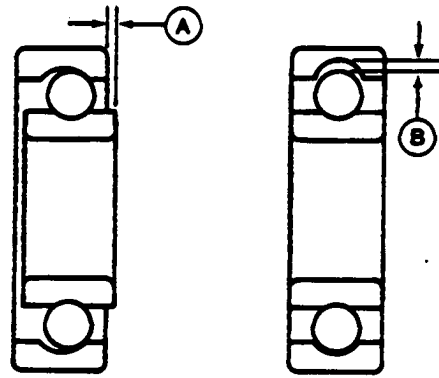

M38073 -UN-29AUG88

-UN-23JUN95

M53023

50
10
11

MX,5010CL,A49 -19-23OCT95

INSPECT PUMP CYLINDER—ASSEMBLY

NOTE: Pump cylinder assembly does not use piston springs.

1. Clean and inspect pump cylinder block assembly (A). (See Inspect Motor Cylinder Assembly in this group.)
2. Measure cylinder spring (B). Replace if cracked or free length is less than specifications.

SPECIFICATIONS

Piston O.D. (Minimum)	19.98 mm (0.787 in.)
Piston Ring to Groove Clearance (Maximum)	0.60 mm (0.024 in.)
Cylinder Spring Free Length (Minimum)	34.5 mm (1.36 in.)
Cylinder Spring Free Length (NEW)	
PA420A/PA540A-AS00 and BS00	45.6 mm (1.80 in.)
PA420A/PA540A-AS01 and AS02	44.7 mm (1.76 in.)
Cylinder Bore I.D. (Maximum)	20.05 mm (0.789 in.)

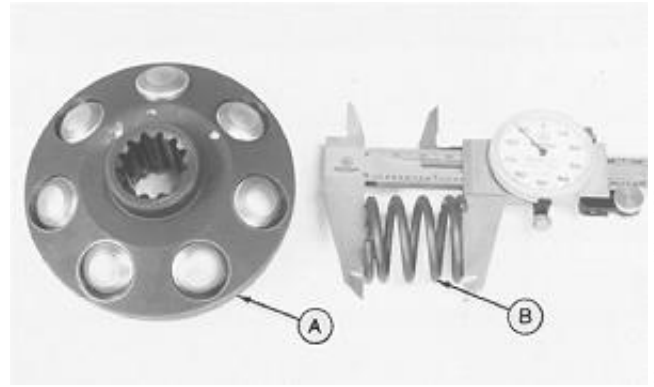

M53024 -UN-05APR89

MX,5010CL,A50 -19-23OCT95

50
10
12

INSPECT CONTROL LEVER SHAFT

1. Inspect O-ring (A).
2. Drive spring pin (B) out from side shown.
3. Remove shaft.
4. Inspect seal (C).
5. Replace damaged parts as necessary.

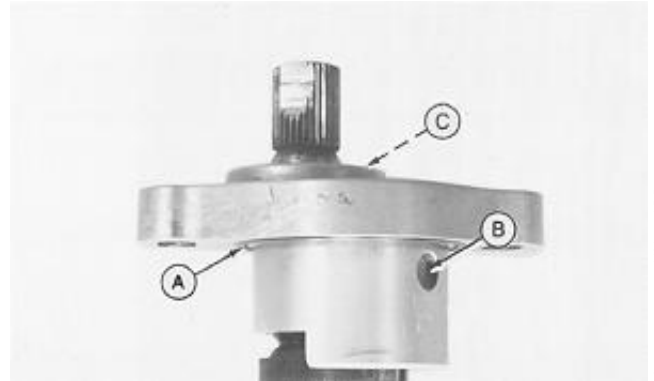

M53025 -UN-05APR89

MX,5010CL,A51 -19-23OCT95

ASSEMBLE SWASH PLATE

IMPORTANT: Lubricate parts with clean engine oil to prevent damage when operated.

1. Install pump drive shaft assembly (D).
2. Install snap ring (C).
3. Install wear cups (B) and balls (A).

A—Balls
B—Wear Cups
C—Snap Ring
D—Pump Drive Shaft

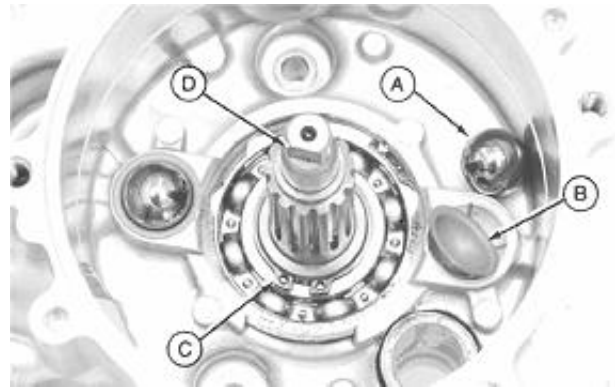

M46186
-UN-22APR92

MX,5010CL,A52 -19-04MAY92

4. Install swash plate (C).
5. Install snap ring (B).
6. Install assembly (A). Align index mark (D) on shaft with centers of holes (E). Tighten cap screws to **24.5 N·m (217 lb-in.)**. Adjust when machine is running. (See Control Valve Adjustment in Section 250, Group 15.)

A—Control Shaft Assembly
B—Snap Ring
C—Swash Plate
D—Index Mark
E—Elongated Holes

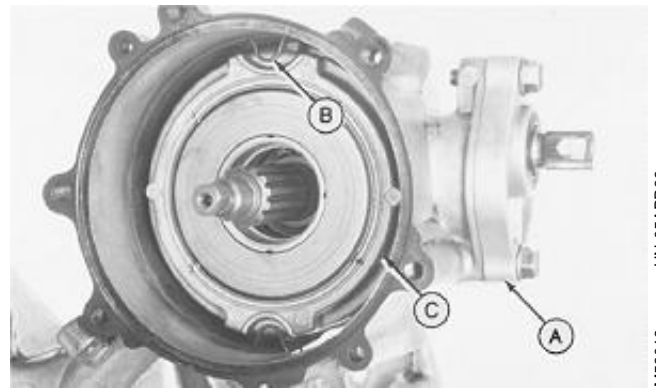

M53019
-UN-05APR89

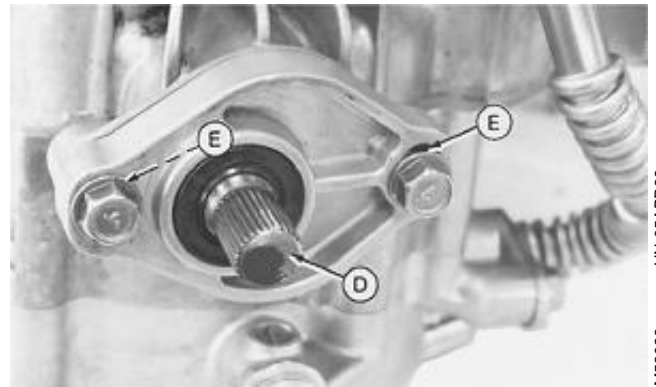

M53026
-UN-05APR89

MX,5010CL,A53 -19-23OCT95

REMOVE AND INSTALL AXLE ASSEMBLIES

NOTE: Axle assemblies can be removed without disassembling transaxle.

1. Remove snap ring (A).
2. Install puller in threaded axle hole (B). Remove axle/bearing assembly carefully to avoid seal damage.

NOTE: Seal removal from right side of differential housing requires differential disassembly. (See Disassemble Differential in this group.)

3. Remove seal (C), if necessary.
4. Install seal **2 mm (0.079 in.) below ball bearing shoulder**. Flat side of seal faces out.
5. Install axle/bearing assembly until bearing bottoms in housing.
6. Install snap ring.

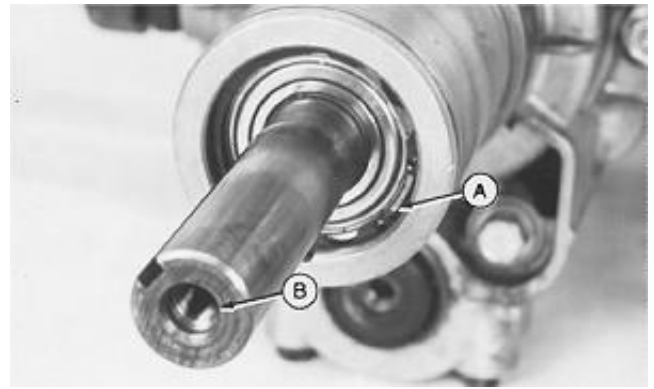

M52985 -UN-05APR89



M52986 -UN-05APR89

MX,5010CL,A1 -19-23OCT95

50
10
14

INSPECT AXLE ASSEMBLY

IMPORTANT: Dry parts with compressed air. Lint from cloth rags can damage transmission.

CAUTION: Do not allow compressed air to spin dry bearings. Bearing can shatter causing injury.

1. Clean ball bearing with solvent and dry with compressed air, **while keeping the bearing from spinning**.
2. Check ball bearing for axial (A) and radial (B) free play. Rotate bearing slowly. Replace if free play is excessive or bearing does not operate smoothly.

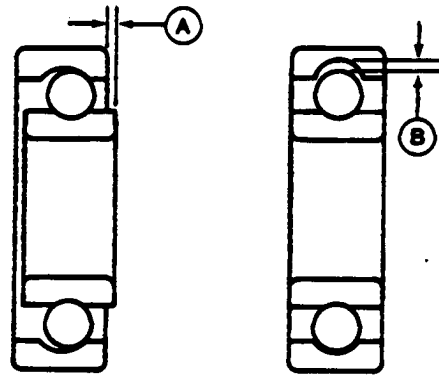

M38073 -UN-29AUG88

MX,5010CL,A2 -19-23OCT95

3. Check axle run-out using V-blocks and dial indicator.
Replace axle if not within specifications.

4. Measure outside diameter of journals (A) and (C).
Replace axle if not within specifications.

5. Inspect journal (B) and spline (D) for nicks, scoring or damage. Blend spline nicks using fine grade oil stone.
Replace axle if necessary.

SPECIFICATIONS

	Transmission Axle	Differential Axle
Run-Out (MAX)	1.6 mm (0.06 in.)	0.6 mm (0.024 in.)
Journal (B) O.D. (MIN)	25 mm (0.984 in.)	
Journal (C) O.D. (MIN)	24.9 mm (0.982 in.)	

- A—Ball Bearing Journal
- B—Oil Seal Journal
- C—Needle Bearing Journal
- D—Spline

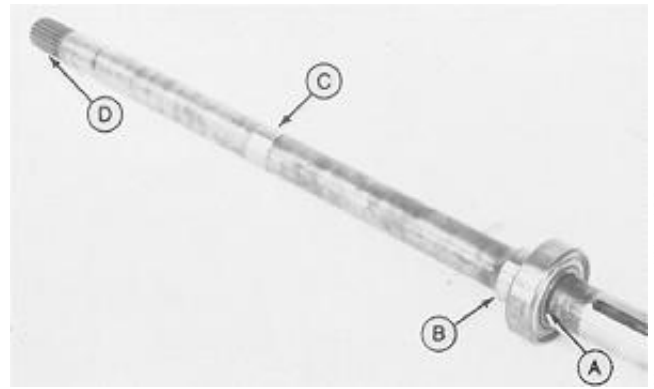

M52987 -UN-05APR89

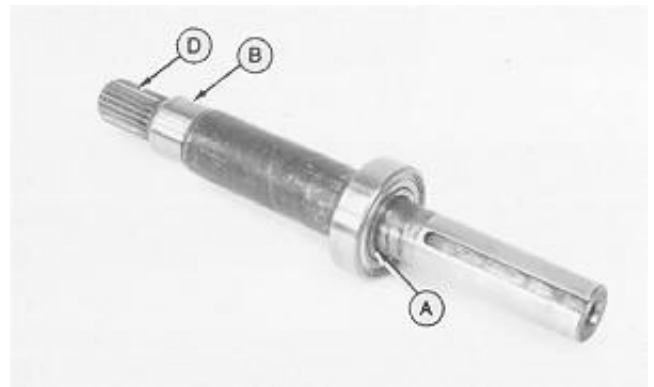

M52988 -UN-05APR89

MX.5010CL.A3 -19-04MAY92

50
10
15

DISASSEMBLE REDUCTION GEAR ASSEMBLY

1. Remove oil lines (A).

NOTE: DO NOT remove cap screws (B).

2. Remove transmission assembly (C) carefully to avoid dropping loose parts.

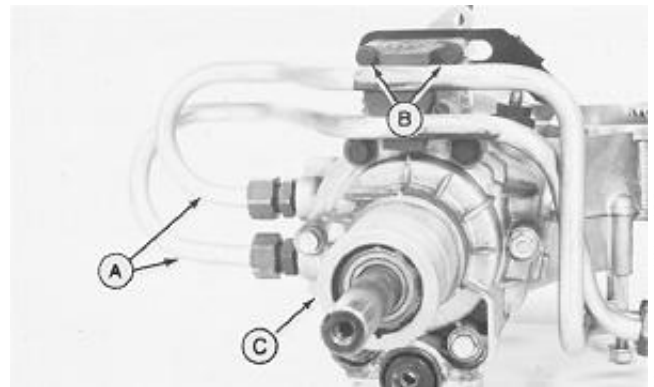

M52989 -UN-05APR89

MX.5010CL.A4 -19-23OCT95

3. Remove shaft (A).

4. Remove spacer (B).

NOTE: When case is removed, 26 rollers will be loose.

5. Remove case (C) and rollers (D).

6. Remove gear (E).

A—Output Shaft
B—Spacer
C—Case
D—Rollers
E—Cycloid Gear

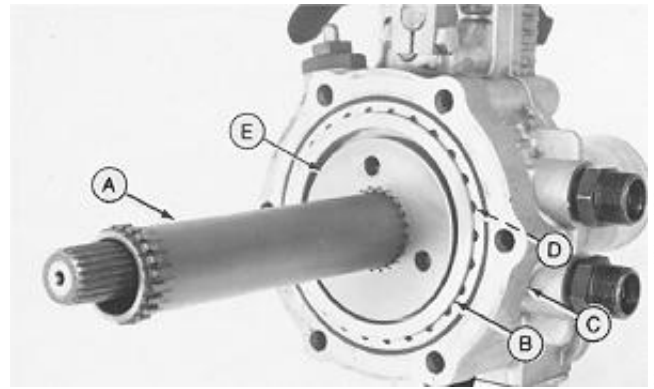

M52990
-UN-05APR89

MX,5010CL,A5 -19-04MAY92

INSPECT ROTATING GROUP

IMPORTANT: Clean parts with solvent and dry parts with compressed air. Lint from cloth rags can damage transmission.

1. Inspect splines on shaft (A) for burrs, nicks and wear. Blend sharp edges with fine oil stone.
2. Inspect gear (B) and spacer (C) for nicks, pitting and wear. Replace if necessary.
3. Inspect rollers (D) and detents (E) for scoring, cracks and overheating. Replace if necessary.
4. Replace O-rings (F) on each side of case if cut or damaged.
5. Inspect wear surface (G). Replace housing if damaged. (See Inspect Fixed Displacement Motor in this group.)
6. For PA420A/PA540A-AS01 and AS02, the roller (H) diameter was changed from **6 mm (0.236 in.)** to **7 mm (0.275 in.)**

*NOTE: The roller case, cycloid gear, and input shaft must be replaced as a set to match the specific roller diameter. An identification groove on the cycloid gear (I) and input shaft (J) indicates that these parts are used with the **7 mm (0.275 in.)** roller.*

- A—Output Shaft
- B—Cycloid Gear
- C—Spacer
- D—6 mm (0.236 in.) Roller
- E—Roller Detent
- F—O-Ring
- G—Gear Wear Surface
- H—7 mm (0.275 in.) Roller
- PA420A/PA540A-AS01 and AS02
- I—Cycloid Gear Identification Groove
- PA420A/PA540A-AS01 and AS02
- J—Input Shaft Identification Groove
- PA420A/PA540A-AS01 and AS02

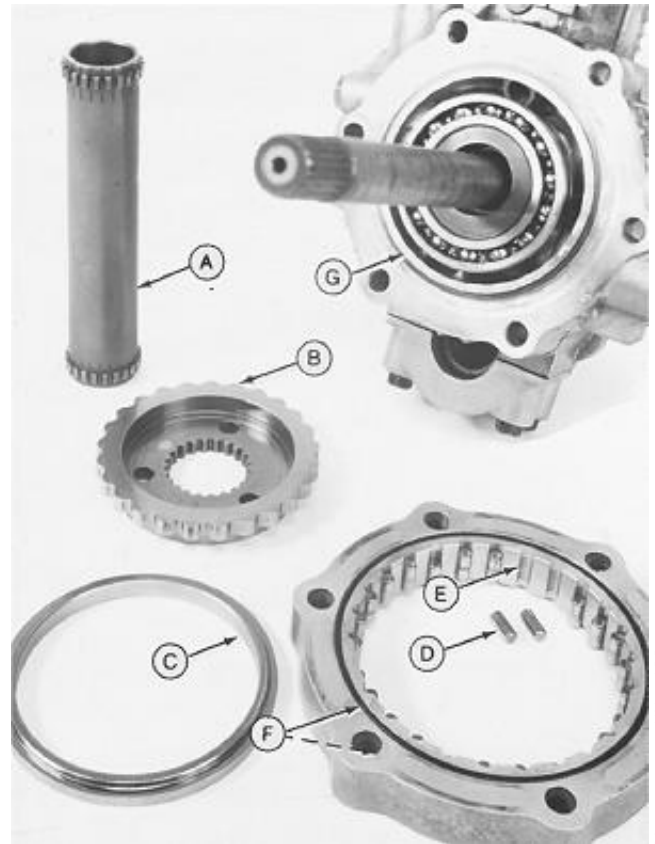

PA420A/PA540A-AS01 Shown

MX.5010CL.A6 -19-23OCT95

ASSEMBLE ROTATING GROUP

IMPORTANT: Coat parts with clean engine oil before assembly to prevent damage during start-up.

1. Install spacer (F), if equipped, and gear (E).
2. Install case (C) and O-rings.
3. Install (26) rollers (D).
4. Install spacer (B).
5. Install shaft (A).

A—Output Shaft
B—Spacer
C—Case
D—Rollers
E—Cycloid Gear
F—Spacer

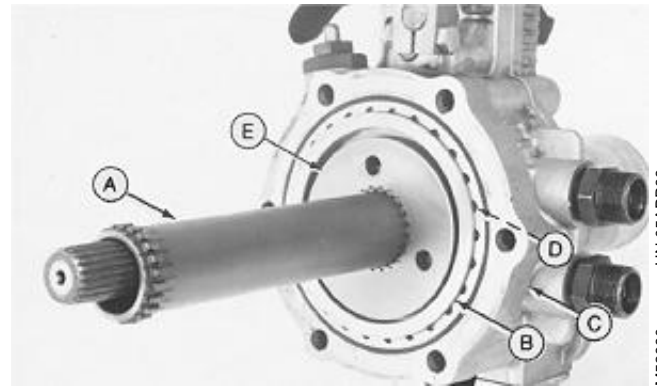
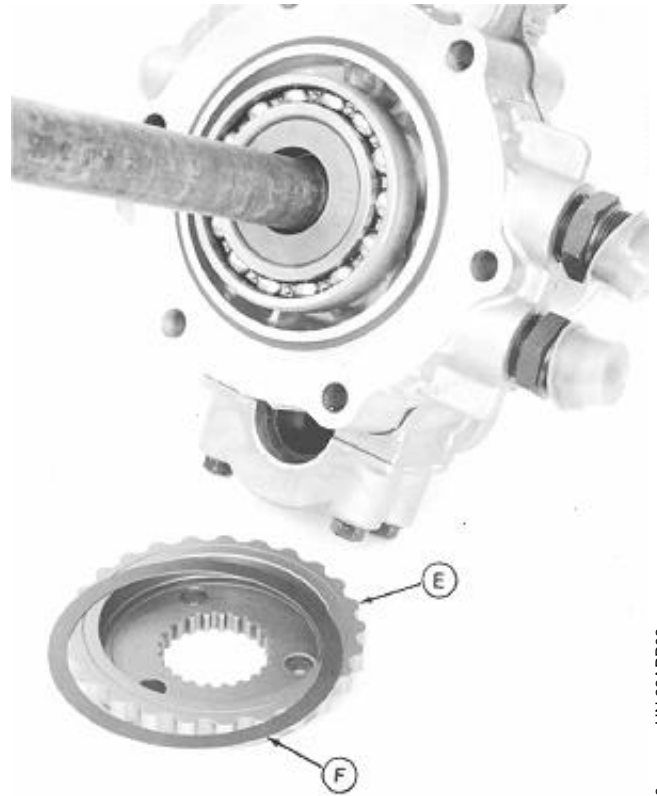

-JUN-22APR92

M46188

-JUN-05APR89

M52990

MX,5010CL,A7 -19-23OCT95

6. Install transmission assembly (C). Tighten axle housing cap screws, in sequence show, to initial torque of **30 N·m (22 lb-ft)**. Then in **5 N·m (44 lb-in.)** increments to final torque of **42 N·m (31 lb-ft)**.

7. Check torque of cap screws (B). Torque should be **25.5 N·m (225 lb-in.)**.

8. Install oil lines (A). Tighten nuts to **79 N·m (58 lb-ft)**.

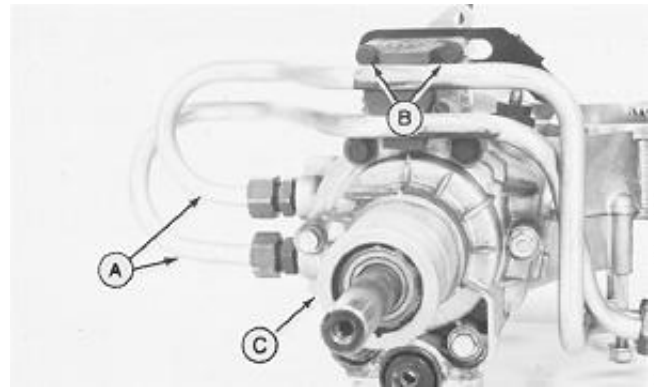

M52989 -UN-05APR89

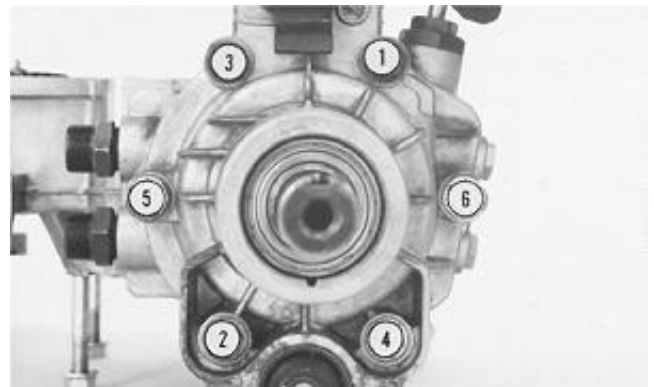

M52992 -UN-05APR89

MX,5010CL,A7A -19-23OCT95

DISASSEMBLE FIXED DISPLACEMENT MOTOR

1. Remove axle assembly. (See Remove and Install Axle Assemblies in this group.)

2. Remove rotating group. (See Disassemble Reduction Gear Assembly in this group.)

3. Remove nuts, spacers, and bracket (A).

4. Remove cap screws (B).



M52993 -UN-05APR89

MX,5010CL,A9 -19-23OCT95

5. Place motor on bench with axle extension upwards. Tap housing with soft mallet to separate housings. Remove eye (A) from pin in axle housing.

NOTE: Spring (B) not used in PA420A/PA540A-AS01 and AS02 motors.

6. Remove spring (B) if equipped, cylinder block assembly (C) and shaft assembly (D) from housing.

7. Remove and discard gasket (E).

8. Remove plugs (F) and pipe joints (G) only if they show signs of leakage.

9. DO NOT disassemble Free-wheeling valve (H) unless it shows signs of leakage. (See Inspect Free-Wheeling Valve in this group.)

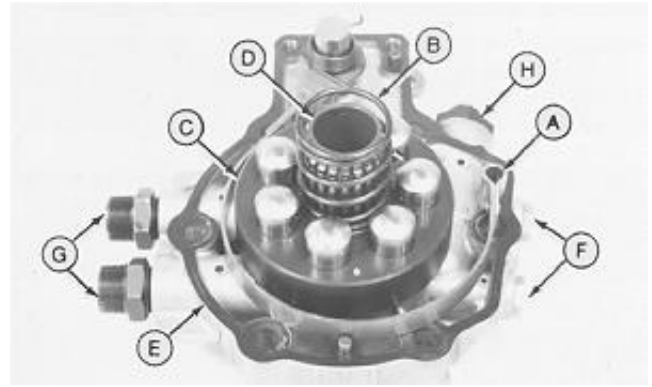

- A—Brake Band Eye
- B—Spring (PA420A/PA540A-AS00 and BS00 only)
- C—Cylinder Assembly
- D—Input Shaft
- E—Gasket
- F—Plug
- G—Pipe Joint
- H—Free-wheeling Valve

M52994 -UN-05APR89

MX,5010CL,A10 -19-23OCT95

50
10
20

INSPECT FIXED DISPLACEMENT MOTOR HOUSING

1. Clean in solvent and dry with compressed air. Be sure all oil passages are clear.

2. Put light weight oil on needle bearing (A). Rotate bearing and check for smooth operation.

CAUTION: DO NOT heat oil over 182°C (360°F). Oil fumes or oil can ignite above 193°C (380°F). Use a thermometer. DO NOT allow a flame or heating element to come in direct contact with the oil. Heat the oil in a well-ventilated area. Plan a safe handling procedure to avoid burns.

3. If necessary, remove snap ring (B) to remove bearing. Heat housing in oil bath at about 165°C (327°F). Press bearing out towards snap ring side of housing.

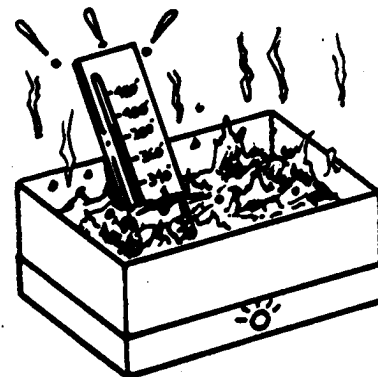
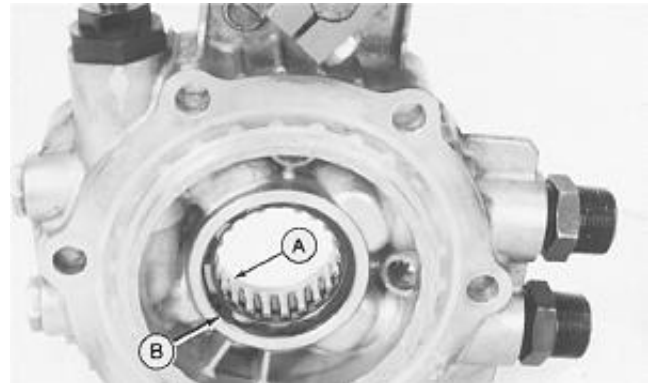

M52995 -UN-05APR89

T81191 -UN-23FEB89

MX,5010CL,A11 -19-23OCT95

4. Inspect cylinder sealing surface (A). Reface if necessary, with a fine grade oil stone.

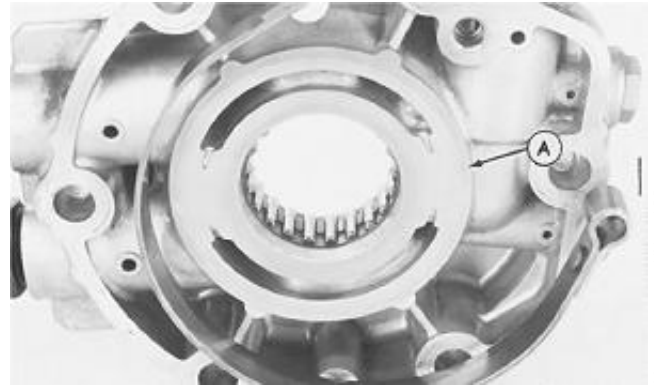

MX,5010CL,A12 -19-04MAY92

M52996 -UN-05APR89

INSPECT INPUT SHAFT ASSEMBLY

CAUTION: DO NOT allow compressed air to spin dry bearing. Bearing can shatter causing injury.

NOTE: Needle bearing (D) is not used in PA420A/PA540A-AS01 and AS02 motors.

1. Clean bearings (C) and (D) in solvent and dry with compressed air, **while keeping the bearing from spinning.**
2. Coat bearings with light oil and check for smooth operation.
3. Check ball bearing for excessive axial (A) and radial (B) play. Replace bearings if necessary.
4. Measure outside diameters of journals (E) and (F). Replace shaft if not within specifications.
5. Inspect spline for damage. Blend nicks with fine grade oil stone. Replace shaft if cracked.

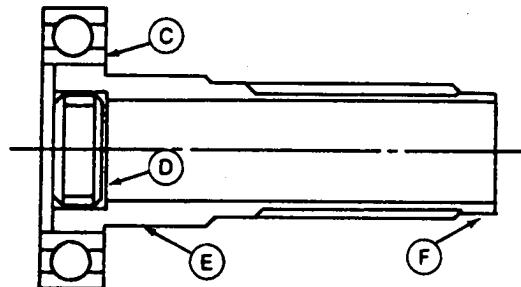
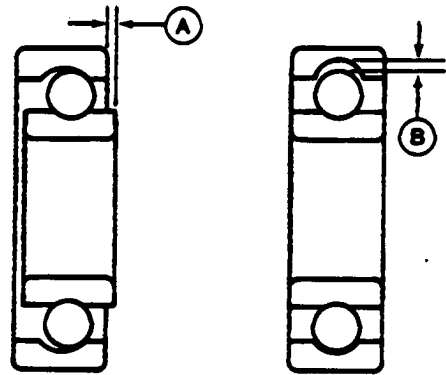

SPECIFICATIONS

Journal (E) (Minimum)	39.97 mm (1.573 in.)
Journal (F) (Minimum)	31.94 mm (1.258 in.)

- A—Axial Play
- B—Radial Play
- C—Ball Bearing
- D—Needle Bearing
(PA420A/PA540A-AS00 and BS00)
- E—Journal
- F—Journal

MX,5010CL,A13 -19-23OCT95

M38073 -UN-29AUG88

50
10
21

M52997 -UN-05APR89

INSPECT MOTOR CYLINDER ASSEMBLY

NOTE: Pistons can be installed in any cylinder bore.

1. Measure outside diameter of piston (A). Replace piston if **less than 19.98 mm (0.787 in.)**.
2. Check groove (D) for wear. Install new ring and measure clearance between ring and groove. Replace if piston if clearance is **less than 0.60 mm (0.024 in.)**.
3. Inspect pistons for scoring or ring land fractures.
4. Measure free length of spring (B). Replace if **less than 27 mm (1.063 in.)**.
5. Measure inside diameter of bore (C). Replace cylinder if **greater than 20.05 mm (0.789 in.)**.

Replace cracked or damaged parts.

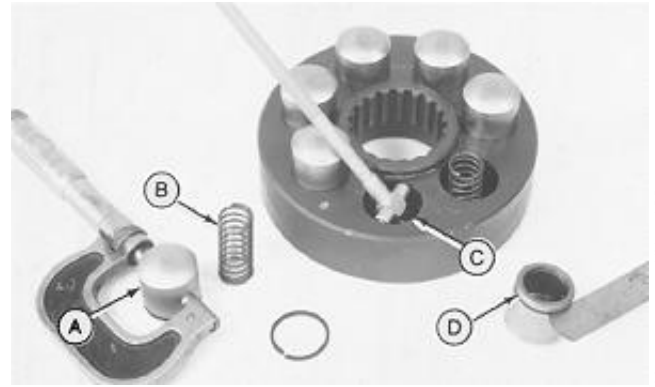

A—Piston
B—Piston Spring
C—Cylinder Bore
D—Piston Ring Groove

M52998 -UN-05APR89

MX,5010CL,A14 -19-23OCT95

50
10
22

NOTE: Retaining spring is not used in PA420A/PA540A-AS01 and AS02 motors.

6. For PA420A/PA540A-AS00 and BS00 motors, replace retaining spring if cracked, damaged or free length is **less than 42 mm (1.65 in.)**.
7. Check spline (A) for damage. Blend nicks with fine grade oil stone.
8. Smooth seating surface (B), if necessary, with fine grade oil stone.

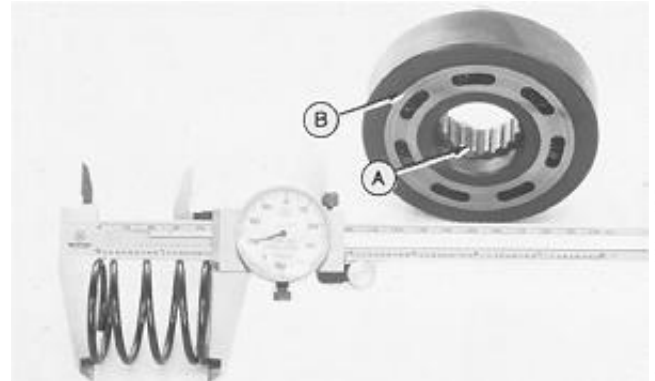

M52999 -UN-05APR89

MX,5010CL,A15 -19-23OCT95

INSPECT AXLE HOUSING

IMPORTANT: Dry parts with compressed air. Lint from cloth rags can damage transmission.

CAUTION: DO NOT allow compressed air to spin dry bearing. Bearing can shatter causing injury.

1. Clean needle bearing (A), thrust plate (B), and ball bearing (C) with solvent and dry with compressed air, **while keeping the bearing from spinning.**
2. Coat bearings with light weight oil. Check for smooth operation. Replace if noisy or rough.
3. Check thrust plate for cracks or burrs. Replace if damaged.



M53000 -UN-05APR89

MX,5010CL,A16 -19-23OCT95

4. Check ball bearing for axial (A) and radial (B) play. Replace if excessive.
5. Remove thrust plate assembly, if necessary. Use an inside puller.
6. Remove ball bearing, if damaged.

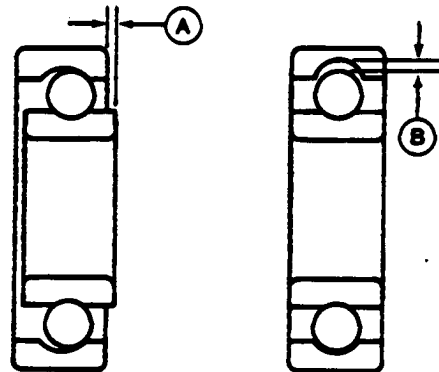

M38073 -UN-29AUG88

MX,5010CL,A17 -19-04MAY92

7. Press ball bearing (C) into housing until it **bottoms on shoulder.**
8. Press thrust plate (B) and needle bearing (A) assembly into housing.



M53000 -UN-05APR89

MX,5010CL,A18 -19-23OCT95

ASSEMBLE FIXED DISPLACEMENT MOTOR

1. If new needle bearing is being installed, place housing on surface plate with sealing surface (A) **face down**. Press bearing in and install snap ring.

2. Install ball bearing **flush** with inside face (B) of eccentric.

NOTE: Needle bearing is not used in PA420A/PA540A-AS01 and AS02 motors.

3. For PA420A/PA540A-AS00 and BS00 motors, install needle bearing **flush** with outside face (C) of eccentric.

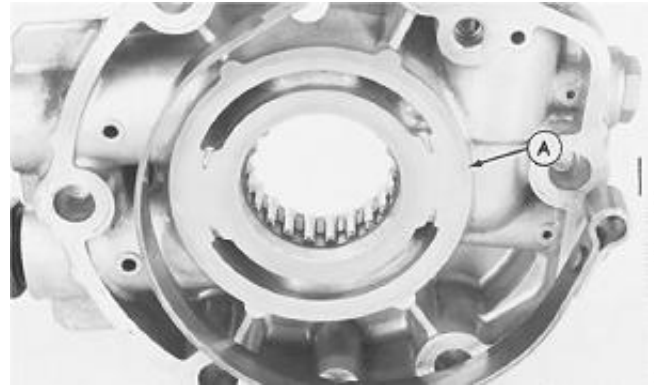

M52996 -UN-05APR89

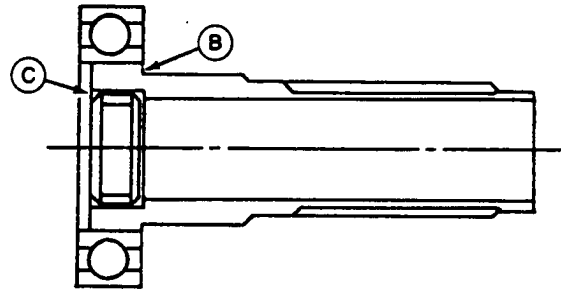

M53001 -UN-05APR89

50
10
24

MX,5010CL,A19 -19-23OCT95

4. Install new gasket (E).

NOTE: Spring (B) is not used in PA420A/PA540A-AS01 and AS02 motors.

5. Install shaft assembly (D), cylinder assembly (C) and spring (B) in housing.

6. Install axle housing on motor housing. Be sure eye (A) is on pin in axle housing.

7. Install plugs (F) and pipe joints (G) if necessary. Lubricate O-rings with petroleum jelly. Tighten to specifications.

8. If necessary, install free-wheeling valve. (See Disassemble and Assemble Free-Wheeling Valve in this group.)

9. Check free movement of push rod (H). Push rod should depress **8 mm (0.31 in.)** and return to original position. (If not, see Inspect Free-Wheeling Valve in this group.)

SPECIFICATIONS

Plug	17.5 N·m (155 lb-in.)
Pipe Joint	100 N·m (74 lb-ft).

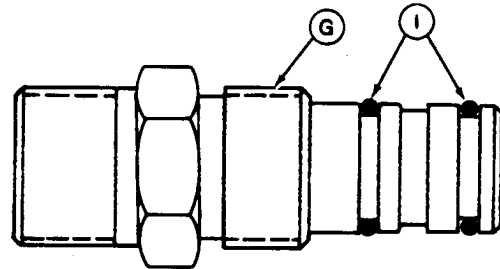
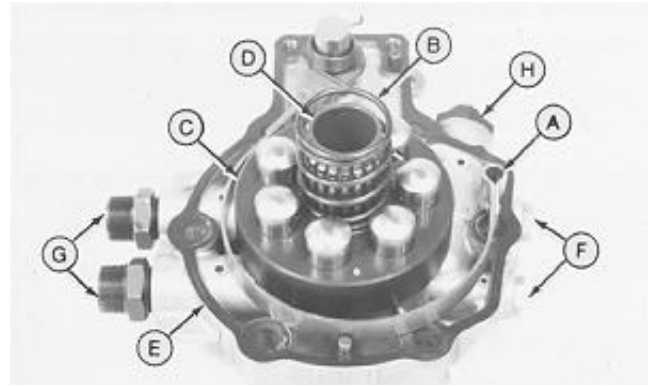

- A—Brake Band Eye
- B—Spring (PA420A/PA540A-AS00 and BS00)
- C—Cylinder Block Assembly
- D—Input Shaft
- E—Gasket
- F—Plug
- G—Pipe Joint
- H—Free-wheeling Valve Push Rod
- I—O-ring

MX,5010CL,A20 -19-23OCT95

10. Install cap screws (B). Tighten to **25.5 N·m (225 lb-in.)**.

11. Install nuts, spacers and bracket (A).

12. Install rotating group. (See Assemble Rotating Group in this group.)

13. Install axle assembly. (See Remove and Install Axle Assemblies in this group.)



MX,5010CL,A21 -19-23OCT95

DISASSEMBLE AND ASSEMBLE FREE-WHEELING VALVE

1. Remove sleeve bolt (A).
2. Remove sleeve (B).
3. Inspect parts. (See Inspect Free-Wheeling Valve in this group.)
4. Lubricate O-rings and install sleeve. Tighten to **41 N·m (30 lb-ft)**.
5. Lubricate and install internal parts. Tighten sleeve bolt to **31 N·m (23 lb-ft)**.

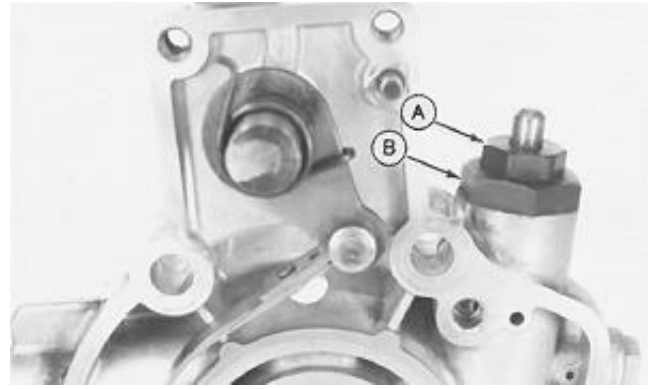

M53002 -UN-05APR89

MX,5010CL,A22 -19-23OCT95

INSPECT FREE-WHEELING VALVE

IMPORTANT: Dry parts with compressed air. Lint from cloth rags can damage unloader valve.

1. Clean parts in solvent and dry with compressed air.
2. Inspect poppet (A) and push rod (B) for scoring or nicks.
3. Inspect for hardened or cracked O-rings (C).
4. Inspect spring (D) for cracks and minimum free length of **16 mm (0.63 in.)**.
5. Replace parts that are damaged or not within specifications.

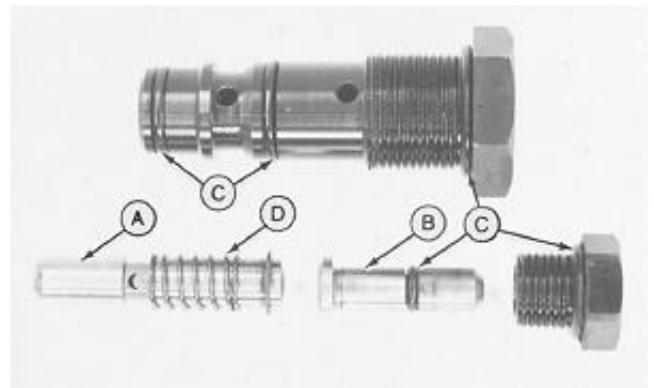

A—Poppet
B—Push Rod
C—O-Ring
D—Spring

M53003 -UN-05APR89

MX,5010CL,A23 -19-23OCT95

DISASSEMBLE DIFFERENTIAL

NOTE: For PA420A/PA540A-AS01, BS00 and AS02, the differential is serviced as an assembly only.

1. Remove axle housing (A).

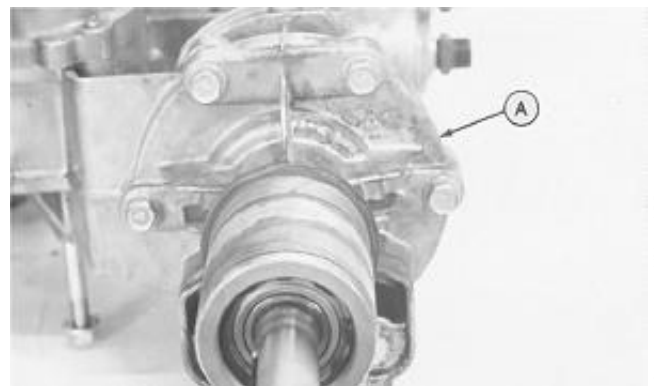

M53050 -UN-13APR89

MX,5010CL,A24 -19-23OCT95

2. Remove differential case (A) from housing.
3. Remove cover (B) from case.
4. Remove washer (C) and gear (D).
5. If seal (E) must be replaced, remove axle assembly.
(See Remove and Install Axle Assemblies in this group.)

A—Differential Case
 B—Differential Cover
 C—Thrust Washer
 D—Bevel Gear
 E—Seal

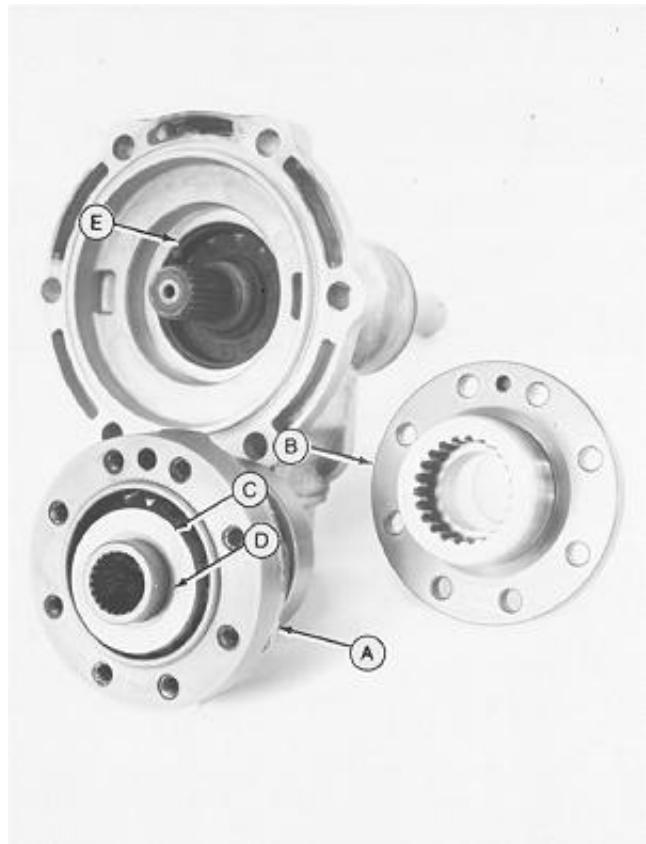

MX,5010CL,A25 -19-23OCT95

M53004 -UN-05APR89

50
10
27

6. Remove shaft (A).
7. Remove pinion gears (B) and bevel gear (C).

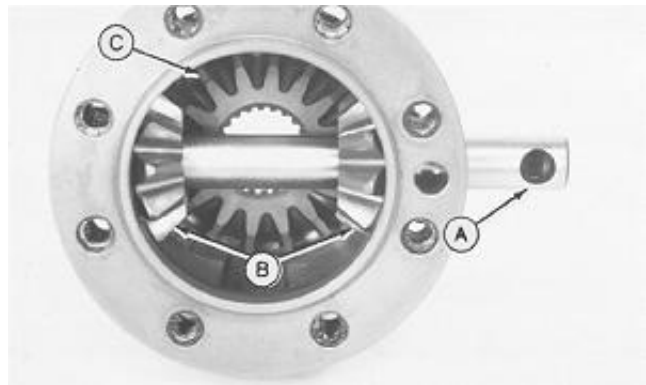

MX,5010CL,A26 -19-04MAY92

M53005 -UN-05APR89

M53005

INSPECT DIFFERENTIAL

1. Inspect seal (A). Replace if damaged.
2. Press seal into housing with spring loaded lip towards differential gears.
3. Press seal in until **2 mm (0.08 in.) below ball bearing shoulder (B)**.
4. Replace O-ring if cracked or damaged.



MX,5010CL,A27 -19-23OCT95

M53006 -UN-05APR89

M53006

5. Measure outside diameter of shaft at areas which contact pinion gear bore. Replace shaft if **less than 13.70 mm (0.539 in.)**.

6. Measure outside diameter of bevel gear journal (A). Replace shaft if **less than 29.91 mm (1.178 in.)**.

7. Measure inside diameter of pinion gear bore. Replace pinion gear if **greater than 14.35 mm (0.565 in.)**.

8. Inspect thrust surface (B) of pinion gear.

9. Inspect gear teeth and spline for cracks, burrs or improper tooth contact.

10. Blend nicks or burrs using a fine grade oil stone. Replace damaged parts.

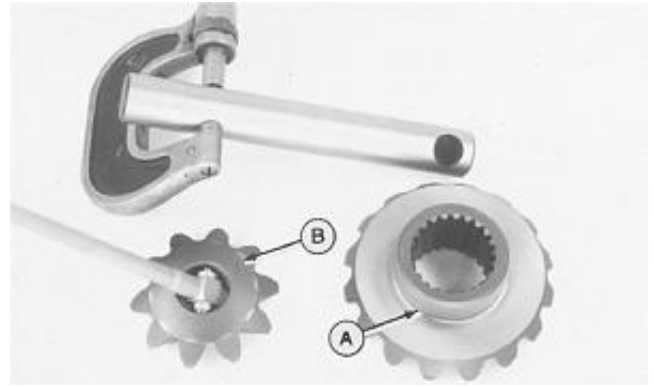

M53007 -UN-05APR89

MX,5010CL,A28 -19-23OCT95

11. Inspect pinion gear seating surfaces (A). Polish scuffs or scratches with crocus cloth and oil.

12. Measure inside diameters (B) of case and cover. Replace if **greater than 30.08 mm (1.184 in.)**.

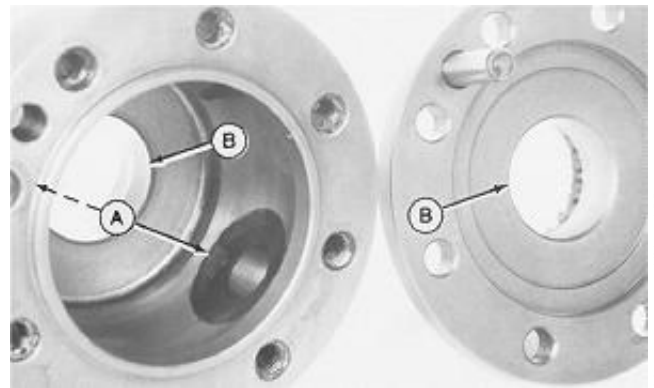

M53008 -UN-05APR89

MX,5010CL,A29 -19-23OCT95

IMPORTANT: Dry parts with compressed air. Link from cloth rags can damaged transmission.

CAUTION: Do not allow compressed air to spin dry bearing. Bearing can shatter causing injury.

13. Clean ball bearing in solvent and dry with compressed air, **while keeping the bearing from spinning**.

14. Coat ball bearing with light oil and check for smooth operation. Replace if rough or if axial (A) or radial (B) play is excessive.

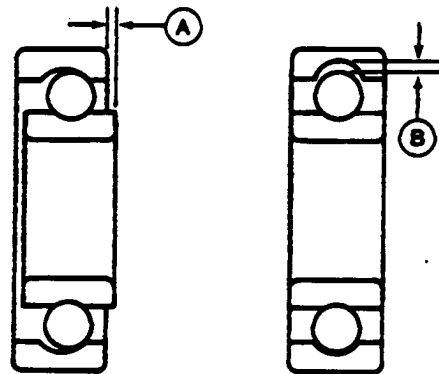

M38073 -UN-29AUG88

MX,5010CL,A30 -19-23OCT95

15. If bearing has been removed, measure outside diameter of case journal (A). Replace case if journal O.D. is **less than 55.93 mm (2.202 in.)**.

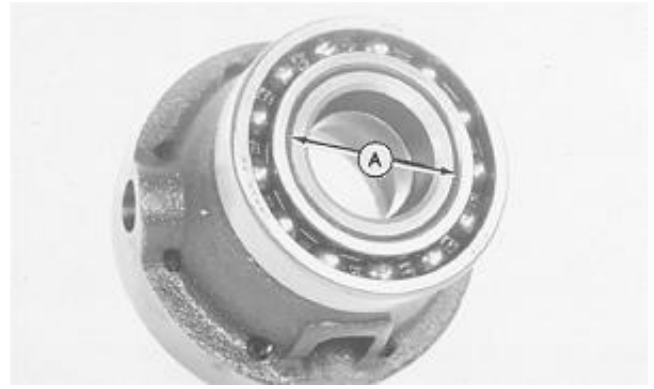

MX,5010CL,A31 -19-23OCT95

M53009 -UN-05APR89

ASSEMBLE DIFFERENTIAL

IMPORTANT: Coat parts with fresh engine oil to prevent damage upon operation.

1. Install bevel gear (C) and pinion gears (B).
2. Install shaft as shown so hole (A) in shaft aligns with locating hole in case.

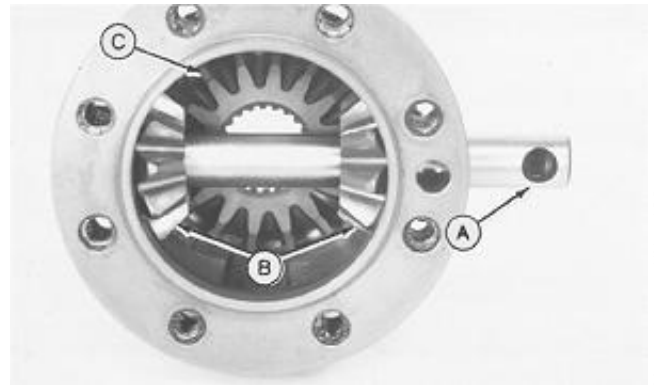

MX,5010CL,A32 -19-04MAY92

M53005 -UN-05APR89

3. Oil lip of seal (E) and check that spring is in place.
4. Install gear (D) and washer (C).
5. Install cover. Tighten cap screws in staggered sequence to **25.5 N·m (225 lb-in.)**.
6. Install differential case (A) into housing.

A—Differential Case
B—Differential Cover
C—Thrust Washer
D—Bevel Gear
E—Seal

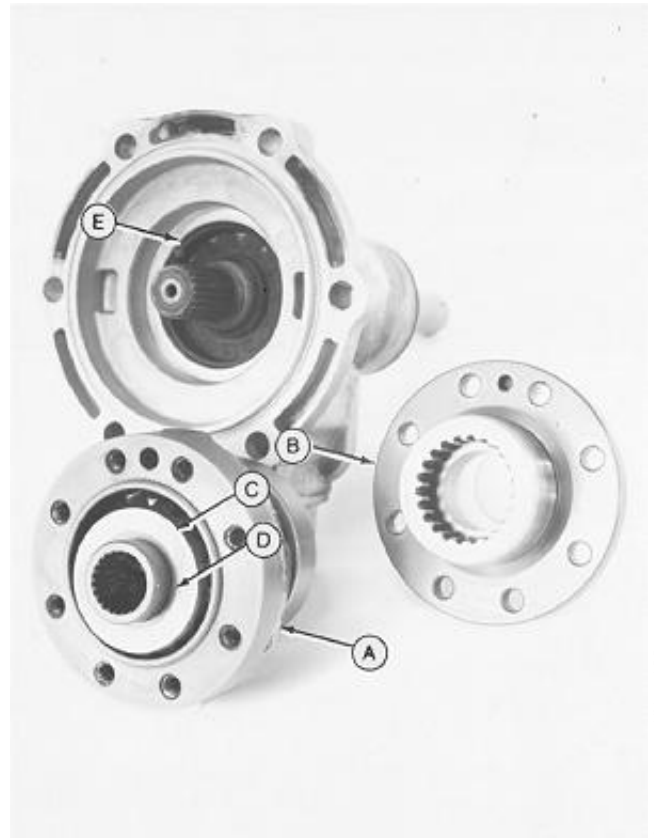

MX,5010CL,A33 -19-23OCT95

M53004 -UN-05APR89

7. Install axle housing/differential assembly (A) and O-ring. Tighten cap screws in sequence shown to initial torque of **30 N·m (22 lb-ft)**. Then in **5 N·m (44 lb-in.)** increments to final torque of **42 N·m (31 lb-ft)**.

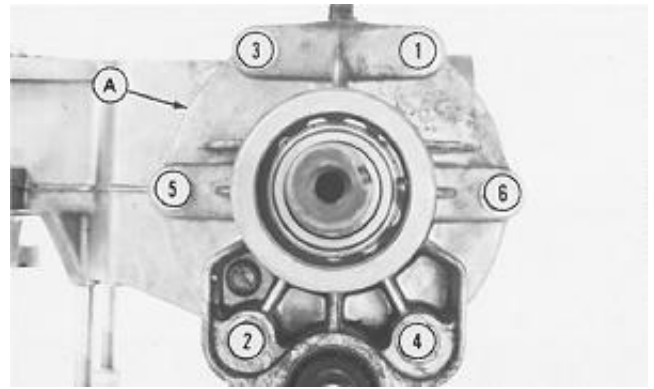

MX,5010CL,A34 -19-23OCT95

M53010 -UN-05APR89

INSPECT DIRECTIONAL PEDALS

1. Check condition of bushings/bearing (A).

(S.N. —100000) Inspect ball bearing in Forward Pedal. Replace if bearing does not turn freely.

Inspect bushing in Reverse pedal. Replace bushing if worn.

(S.N. 100001—) Inspect bushings. Replace if worn.

2. Replace any bent or damaged components.

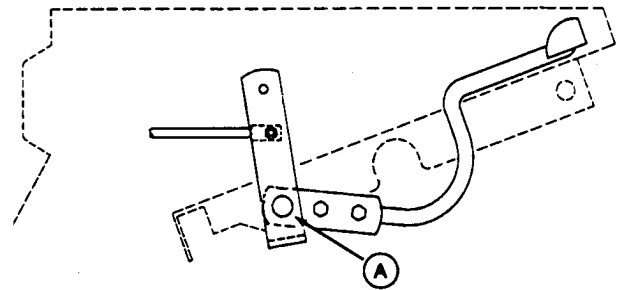

Forward Pedal

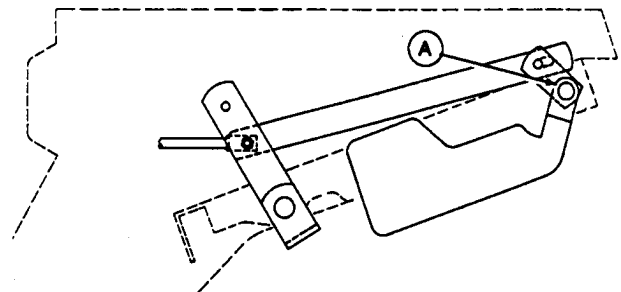

Reverse Pedal

MX,5010CL,A54 -19-23OCT95

-UN-21AUG89

M53156

-UN-21AUG89

M53157

50
10
30

Section 60 STEERING REPAIR

Contents

Page

Group 05—Steering Shaft and Gears

Steering Shaft and Gears

Remove	60-05-1
Inspect	60-05-2
Install	60-05-3

Group 10—Wheels

Remove and Install Wheels	60-10-1
Repair Rear Wheel	60-10-1

REMOVE STEERING SHAFT AND GEARS

1. Disconnect battery negative (—) cable.
2. Remove steering wheel.
3. Remove indicator panel (A).
4. Disconnect indicator lights (B).
5. Remove pedestal (C).

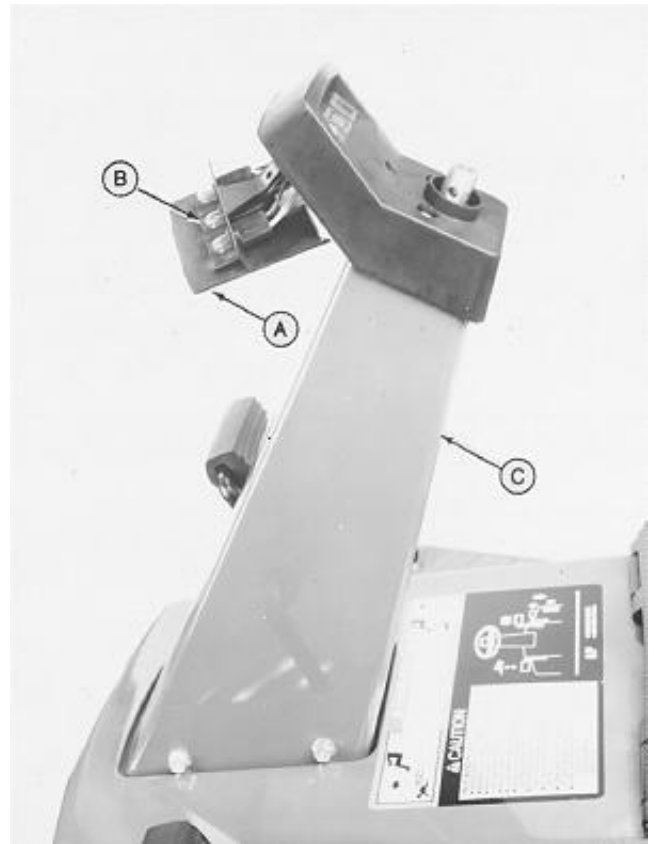

MX,6005CL,A2 -19-23OCT95

M53051 -JUN-13APR89

6. Remove cotter pin (A) and washers.
7. Remove shaft assembly.

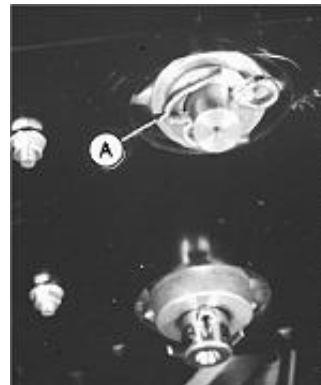

MX,6005CL,A3 -19-04MAY92

M53052 -JUN-13APR89

60-05-1

8. Remove cotter pin, washers and bushing (A).
9. Disconnect drag link (B) from lever.
10. Remove cap screws attaching foot rest (C) to frame.
11. Loosen spring by backing out cap screw (D).
12. Remove cap screws attaching bracket (E) to frame.
13. Remove gear assembly.
14. Disassemble arm (F), gear (G) and bushing (H).

- A—Bushing
- B—Drag Link
- C—Foot Rest
- D—Cap Screw
- E—Bracket
- F—Steering Arm
- G—Sector Gear
- H—Bushing

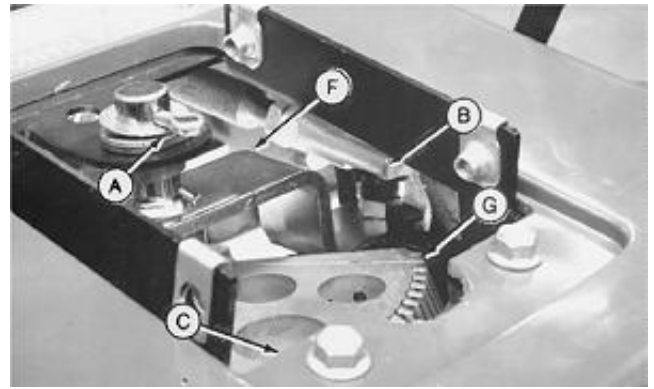

M53084 -UN-13APR89

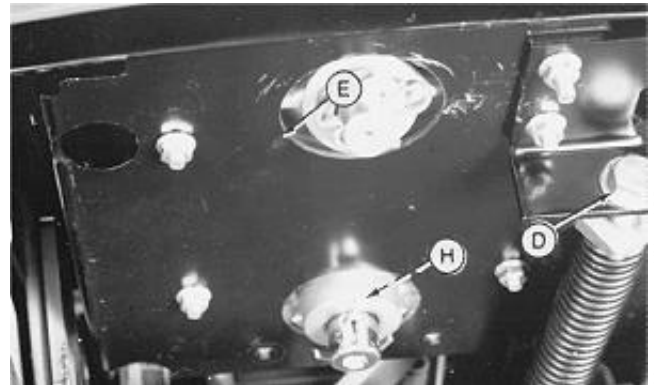

M53085 -UN-13APR89

MX,6005CL,A5 -19-04MAY92

INSPECT STEERING SHAFT AND GEARS

1. Inspect bushings (A) for wear.
2. Inspect gears (B) and (C) for cracks, damage or wear.
3. Inspect arm (D) spline for damage.
4. Inspect plate (E) for cracks or damage.
5. Replace any worn or damaged parts.
6. Tighten draglink rod to ball joint nut to **34 N·m (25 lb-ft)**.

- A—Bushing
- B—Sector Gear
- C—Pinion Gear
- D—Steering Arm
- E—Gear Plate

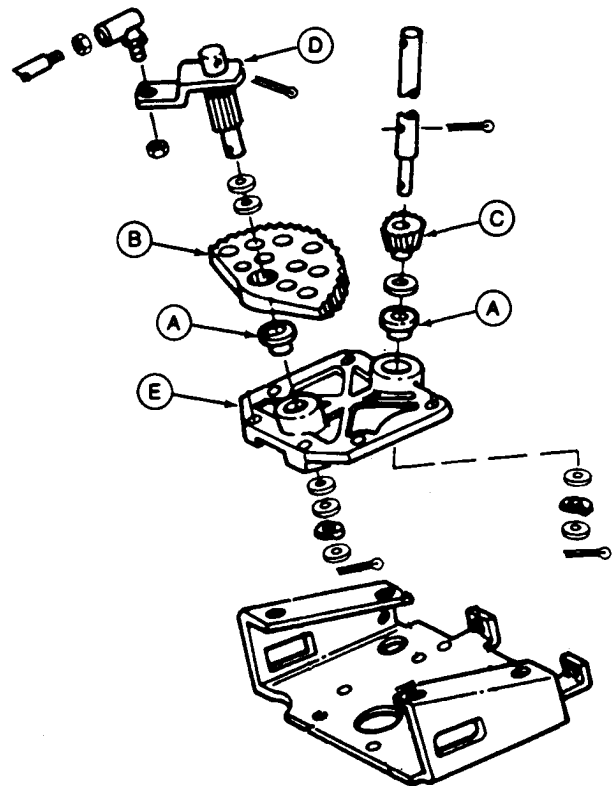

M53092 -UN-20APR89

MX,6005CL,A5A -19-23OCT95

INSTALL STEERING SHAFT AND GEARS

1. Install gear assembly.
2. Install bracket (E) on frame.
3. Adjust cap screw (D) for proper spring tension.
4. Attach foot rest (C).
5. Connect drag link (B). Tighten ball joint to steering arm nut to **37 N·m (27 lb-ft)**.
6. Install bushing (A) and cotter pin.

A—Bushing
 B—Drag Link
 C—Foot Rest
 D—Cap Screw
 E—Bracket
 F—Steering Arm
 G—Sector Gear
 H—Bushing

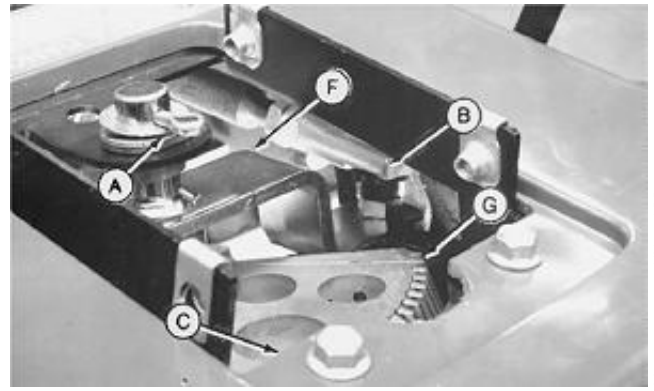

M53084 -UN-13APR89

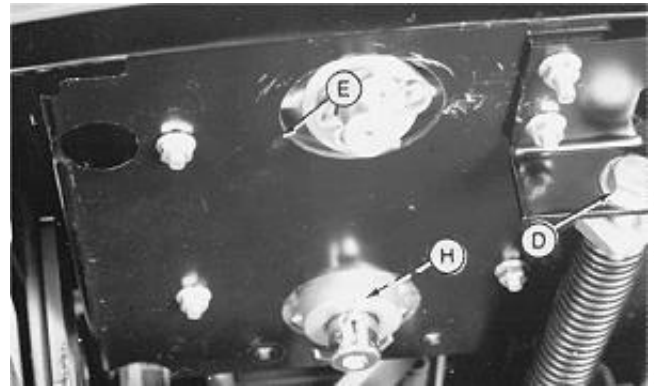

M53085 -UN-13APR89

MX,6005CL,A6 -19-23OCT95

7. Install shaft assembly. Align marks (B) on gears. With marks aligned, sector shaft arm should be at 90° left.
8. Install washers and cotter pin (A).

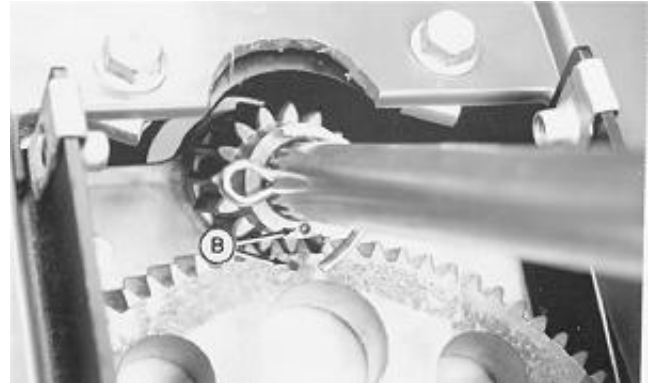

M53054 -UN-13APR89

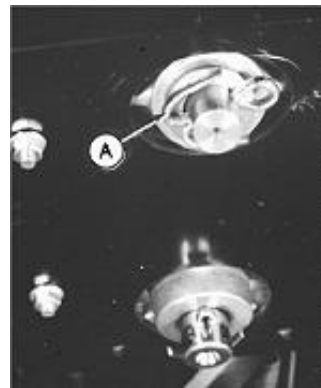

M53052 -UN-13APR89

MX,6005CL,A7 -19-04MAY92

9. Install pedestal (C).
10. Connect indicator lights (B) and panel (A).
11. Install steering wheel.
12. Connect battery negative cable.

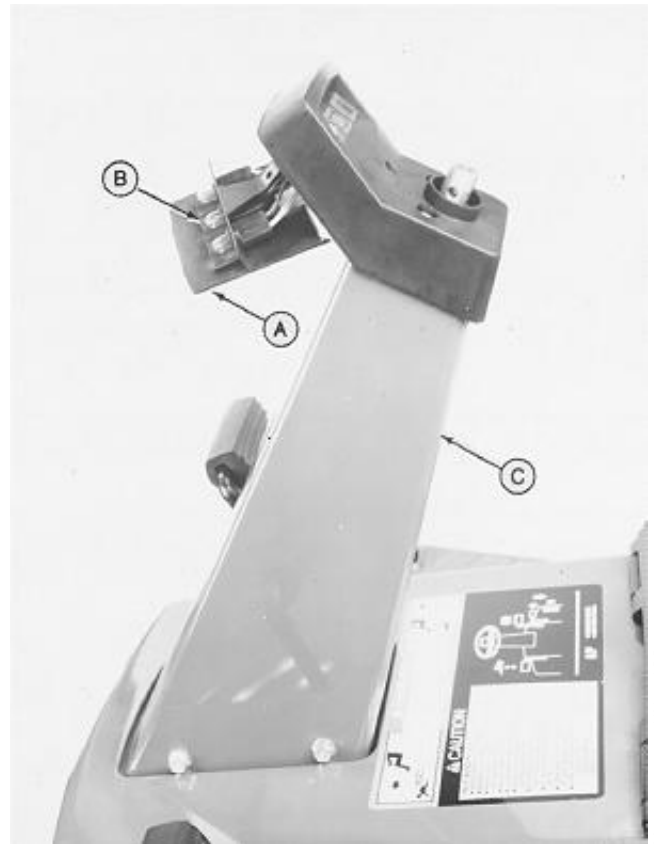

MX,6005CL,A8 -19-04MAY92

M53051 -JUN-13APR89

REMOVE AND INSTALL WHEELS

IMPORTANT: Do not attempt to raise mower with jack under fender. Fenders will be damaged.

1. Remove front wheels:
 - Raise mower at location (B).
 - Remove cap screw (A).
2. Remove rear wheel:
 - Raise mower at location (C).
 - Remove cap screw (D).
3. Install wheel(s).

Tighten front wheel cap screw to **50 N·m (37 lb-ft)**.

A—Cap Screw
B—Lift Point
C—Lift Point
D—Cap Screw

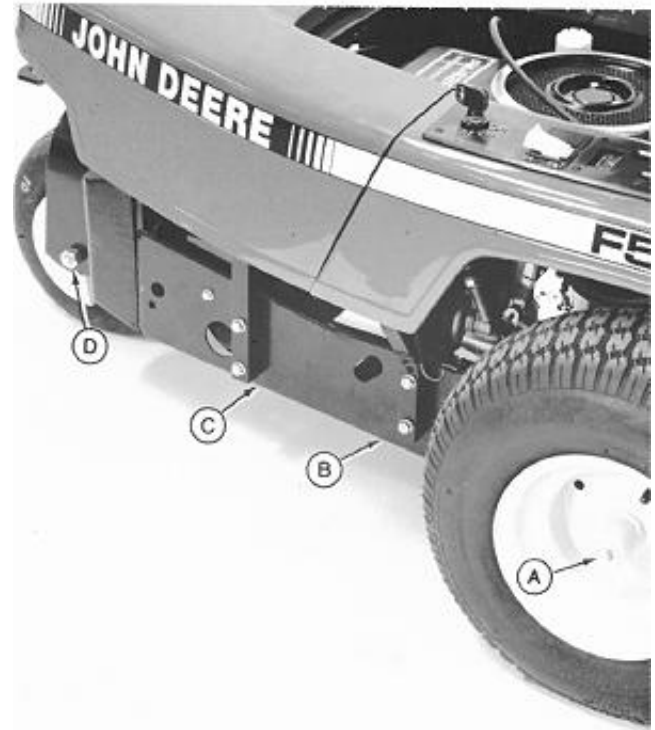

M61961 -JUN-15MAR89

MX.6010CL.A1 -19-23OCT95

REPAIR REAR WHEEL

1. Remove cap screws (A).
2. Remove weights (B). Replace if cracked.
3. Remove sleeve (C).
4. Remove bearing (D) if damaged, using an inside puller.
5. Press in new bearing.
6. Install sleeve and weights.

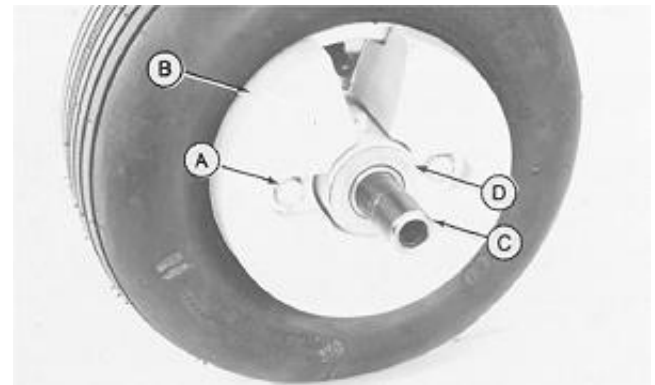

A—Cap Screws
B—Wheel Weight
C—Sleeve
D—Bearing

M53055 -JUN-13APR89

MX.6010CL.A2 -19-04MAY92

60
10
2

Section 65 BRAKE REPAIR

Contents

Page

Group 05—Brake Repair

Remove and Install Brake Band	
Remove and Install Brake Band	65-05-1

REMOVE AND INSTALL BRAKE BAND

1. Remove transmission. (See Remove and Install Engine in Section 20, Group 05.)
2. Remove left axle housing. (See Remove and Install Axle Assemblies in Section 50, Group 10.)
3. Disassemble rotating group. (See Disassemble Reduction Gear Assembly in Section 50, Group 10.)
4. Remove lever (A).
5. Remove shaft (C) and assembly from housing.
6. Replace spring (B) if cracked or weak.
7. Remove band (D) if worn or damaged by removing rivet (E) from band eye.
8. Install band using new rivet.
9. Replace O-ring (F) if hard or damaged.
10. Install shaft assembly and lever.
11. Assemble rotating group. (See Assemble Rotating Group in Section 50, Group 10.)

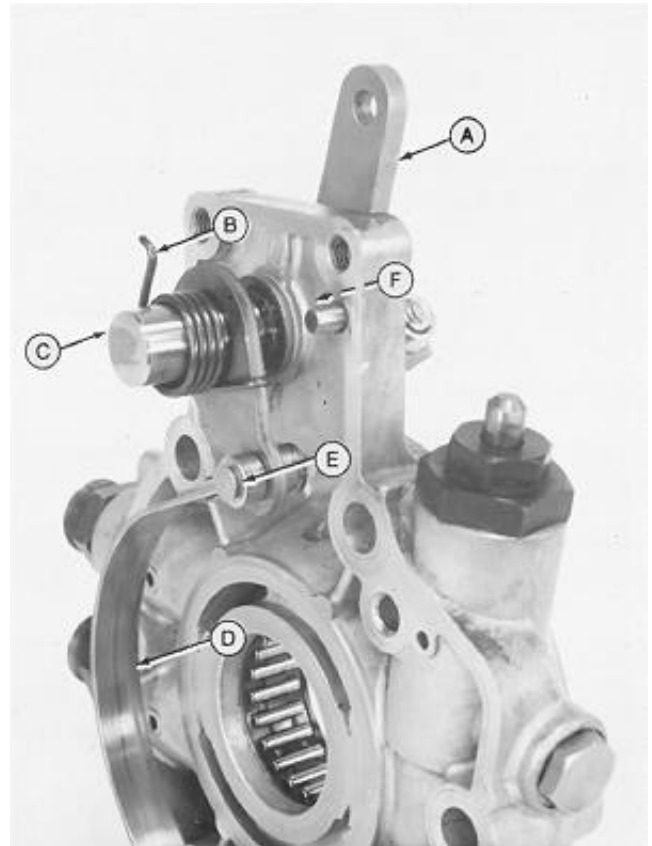

A—Brake Lever
B—Return Spring
C—Brake Shaft
D—Brake Band
E—Rivet
F—O-ring

M53028 -UN-05APR89

MX,5015CL,A2 -19-23OCT95

Brake Repair/Remove and Install Brake Band

65
05
2

Section 80 MISCELLANEOUS

Contents

	Page	Page
Group 05—Mower Deck Repair		
Spindles		
Other Material	80-05-1	
Remove and Install	80-05-1	
Disassemble and Assemble 38-Inch Mower	80-05-2	
Disassemble and Assemble 46-Inch Mower	80-05-3	
Disassemble and Assemble 48-Inch Mower	80-05-4	
Spindles	80-05-5	
Spindles	80-05-6	
Deck Lift Linkage		
F510	80-05-8	
F525	80-05-9	
Pivoting Jacksheave Assembly		
F510	80-05-10	
F525	80-05-11	
Group 10—Blade Drive Belt		
Remove and Install Belts	80-10-1	
Group 15—38-Inch Snowthrower		
Other Material	80-15-1	
Snowthrower Lift Linkage	80-15-2	
Snowthrower Lift Assembly	80-15-3	
Snowthrower Drive Shaft Assembly	80-15-4	
Snowthrower Housing Assembly	80-15-6	
Snowthrower Chute Assembly	80-15-8	
Optional Electric Spout Rotation Kit	80-15-9	
Group 20—Power Flow™ Blower Assembly		
Rotor		
Repair (46-Inch Mower Deck)	80-20-1	
Repair (46-Inch Mower Deck)	80-20-2	
Jacksheave, Idlers and Belt		
Repair (46-Inch Mower Deck)	80-20-3	
Repair (48-Inch Mower Deck)	80-20-4	
Blower Housing		
Repair (46-Inch Mower Deck)	80-20-6	
Repair (48-Inch Mower Deck)	80-20-8	
Hopper Top and Mounting Bracket		
Repair	80-20-10	
Group 25—Engine Shroud and Fenders		
Remove and Install Rear Shroud	80-25-1	
Remove and Install Seat Platform	80-25-1	
Remove and Install Fenders	80-25-3	
Group 30—Weight Transfer System		
Weight Transfer System	80-30-1	

OTHER MATERIAL

Number	Name	Use
M79292	MPG-2® Polymer Multipurpose Grease	Lubricate spindles.

MPG-2® is a registered trademark of DuBois, a division of Chemed Corp.

MX,8005CL,A -19-23OCT95

REMOVE AND INSTALL SPINDLES ASSEMBLIES

NOTE: Early model F510 (38-Inch) Mower shown. Other models similar.

1. Remove mower deck.
2. Disconnect lever (A).
3. Remove cover (B).

⚠ CAUTION: Wear gloves when handling blade to avoid injury.

4. Remove blade.
5. Remove spindle assembly (C).
6. Install spindle assembly. Tighten nuts to **25 N·m (221 lb-in.)**.

⚠ CAUTION: Wear gloves when handling blade to avoid injury.

7. Install blade with concave side of washer facing blade. Tighten cap screw to specifications.
8. Install cover.
9. Connect lever.

SPECIFICATIONS

38-Inch Deck Blade Cap Screw Torque	75 N·m (55 lb-ft)
46-Inch Deck Blade Cap Screw Torque	75 N·m (55 lb-ft)
48-Inch Deck Blade Cap Screw Torque	68 N·m (50 lb-ft)



-JUN-13APR89
M53056

-JUN-13APR89
M53057

80-05-1

DISASSEMBLE AND ASSEMBLE 38-INCH MOWER SPINDLE ASSEMBLY

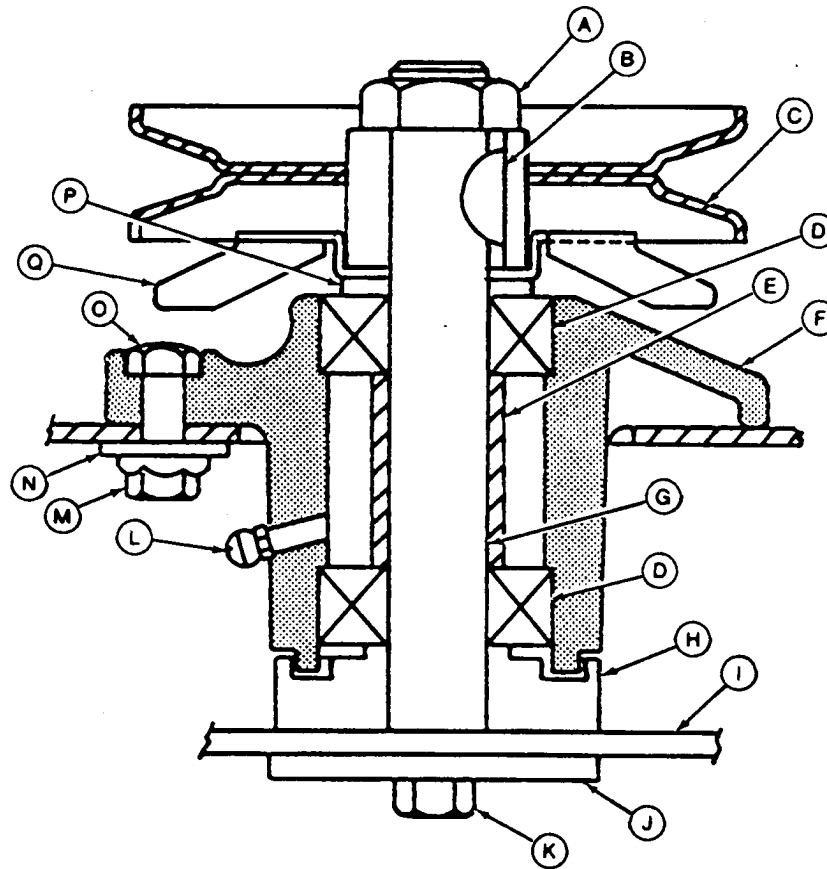

M53090
-UN-20APR89

A—Lock Nut	F—Housing	J—Washer	N—Washer (4 used)
B—Key	G—Spindle Shaft	K—Cap Screw	O—Cap Screw (4 used)
C—Sheave Assembly	H—Hub	L—Grease Fitting	P—Washer
D—Bearing (2 used)	I—Blade	M—Nut (4 used)	Q—Fan
E—Spacer			

NOTE: There are two spindles on the 38-Inch mower.

1. Remove nut (A) and spindle sheave (C).
2. Press spindle shaft (G) down through housing (F).
3. Remove bearings (D) and spacer (E) from housing.
4. Inspect bearings, shaft, spacer and hub for wear or damage. Replace parts if necessary.

IMPORTANT: Support both the inner and outer bearing races when pressing in bearings or shaft.

5. Press top bearing (D) into housing until seated against shoulder.

6. Install spacer (E).
7. Support both inner and outer upper bearing races and install remaining bearing (D) to bottom of bore in housing. Press until bearing is seated against spacer.
8. Align spacer (E) and press shaft (G) into housing.
9. Install key (B), sheave (C) and lock nut (A). Tighten lock nut to **140 N·m (103 lb-ft)**.
10. Fill spindle housing completely with MPG-2® Polymer Multipurpose Grease or equivalent.

MX.7005CL.A2 -19-23OCT95

DISASSEMBLE AND ASSEMBLE 46-INCH MOWER SPINDLE ASSEMBLY

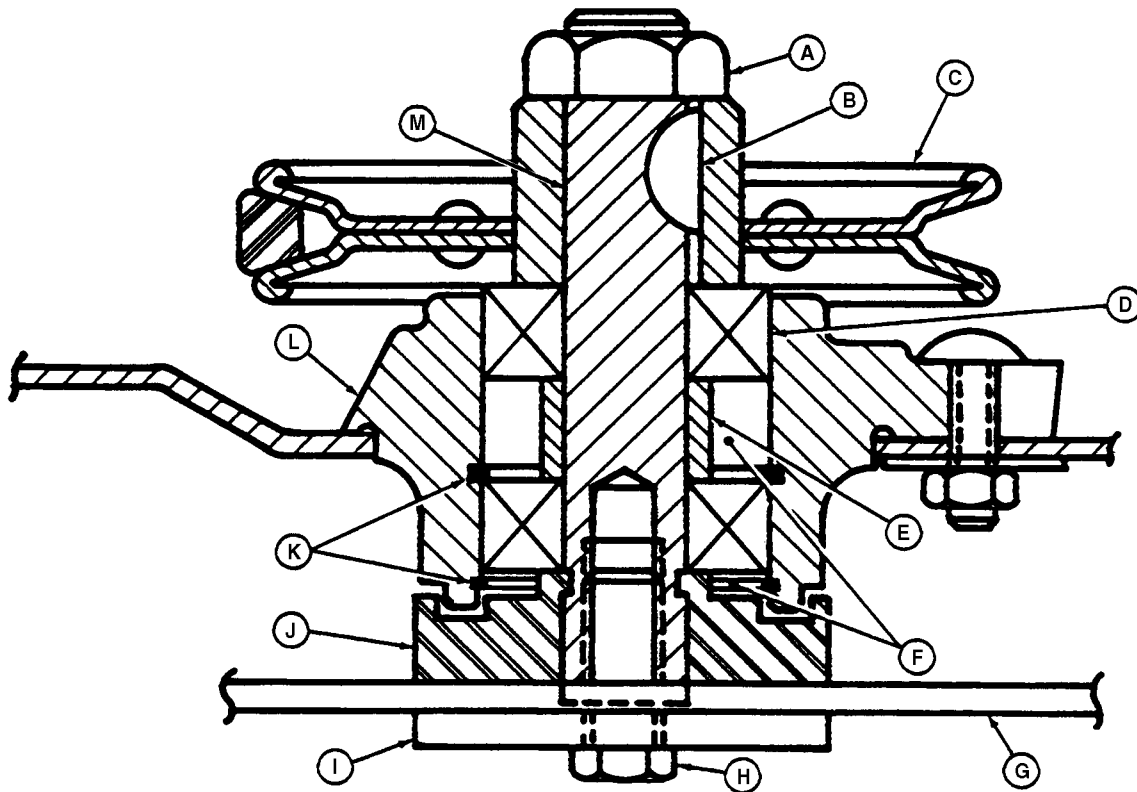

A—Nut	E—Spacer	H—Cap Screw	K—Snap Ring (2 used)
B—Key	F—Grease Areas	I—Washer	L—Housing
C—Sheave	G—Blade	J—Hub	M—Spindle Shaft
D—Ball Bearing (2 used)			

NOTE: There are three spindles on the 46-inch mower.

1. Remove nut (A), sheave (C) and key (B).
2. Press spindle shaft (M) down through housing (L).
3. Remove lower snap ring (K). Press on inner and outer races of upper bearing (D), remove lower bearing and spacer (E).
4. Turn hub over and press upper bearing (D) out.
5. Inspect bearings, shaft, spacer and hub for wear or damage. Replace parts if necessary.
6. Position lower bearing in hub. Make sure land riding seal of bearing is away from hub. Press bearing against upper snap ring.
7. Install spacer (E). Fill area (F) with MPG-2[®] Polymer Multipurpose Grease or equivalent.
8. Support inner and outer races of lower bearing and press upper bearing against against spacer (E), keeping spacer in alignment. Make sure land riding seal of bearing is away from hub.
9. Install lower snap ring (K). Fill area (F) around snap ring with MPG-2[®] Polymer Multipurpose Grease or equivalent.
10. Support inner and outer upper bearing races and press spindle shaft (M) into hub.
11. Check rolling torque of spindle. Maximum allowable torque is **0.07 N·m (0.6 lb-in.)**.

IMPORTANT: Support both the inner and outer bearing races when pressing in bearings or shaft.

M83014 -JUN-11-JUL-95

80
05
3

DISASSEMBLE AND INSPECT SPINDLE

IMPORTANT: DO NOT install hexagon end of spindle shaft in a vise to remove spindle sheave nut. The hexagon end of spindle shaft will be damaged resulting in improper blade operation.

1. Install blade (K), washer (L), and cap screw (M) on spindle shaft. Make sure that the hexagon shaped hole in washer is in alignment with hexagon portion of spindle. If only the nut (A) or spindle sheave (B) need to be replaced, and the spindle is still in the deck, use a block of wood to prevent the blade from turning. If spindle is not in the deck, put blade in a soft jaw vice. Tighten cap screw (M) to **122 N·m (90 lb-ft)**.

2. Hold the blade with a vise or block of wood. Remove nut (A), spindle sheave (B), and lubrication fitting (I).

3. Remove cap screw, washer and blade.

4. Press spindle shaft (J) out of spindle hub (F).

5. Remove seal rings (C) noting location of notched side.

NOTE: Remove bearings only if replacement is necessary.

6. The bearings are seated against the hub shoulder (H) and cannot be removed with a press. Remove seals (D) and bearings (E) using a punch.

7. Remove spacer (G).

8. Inspect parts for wear or damage. Replace as necessary.

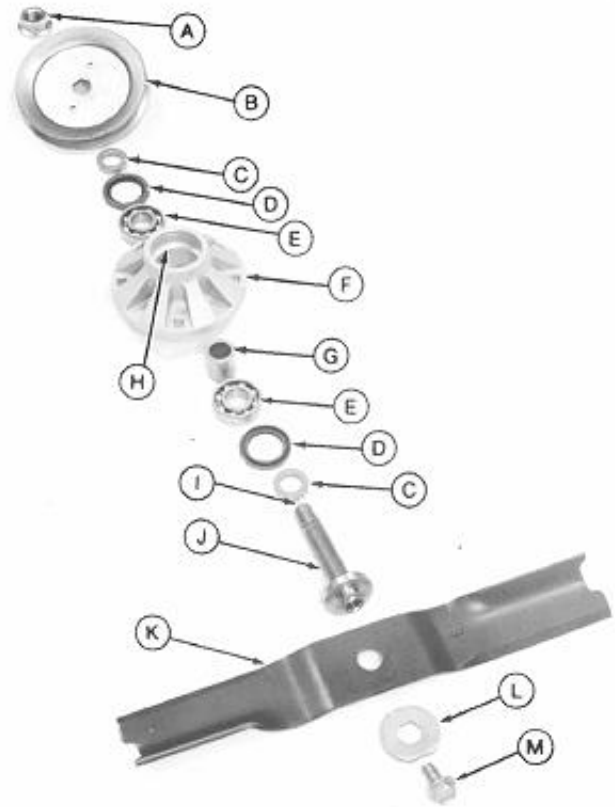

- A—Nut
- B—Spindle Sheave
- C—Seal Ring (2 used)
- D—Seal (2 used)
- E—Bearing (2 used)
- F—Spindle Hub
- G—Spacer
- H—Spindle Hub Shoulder
- I—Lubrication Fitting
- J—Spindle Shaft
- K—Blade
- L—Washer
- M—Cap Screw

M44948 -JUN-20AUG91

80
05
4

MX,8010FS,A7 -19-23OCT95

48-INCH SPINDLE CROSS SECTION

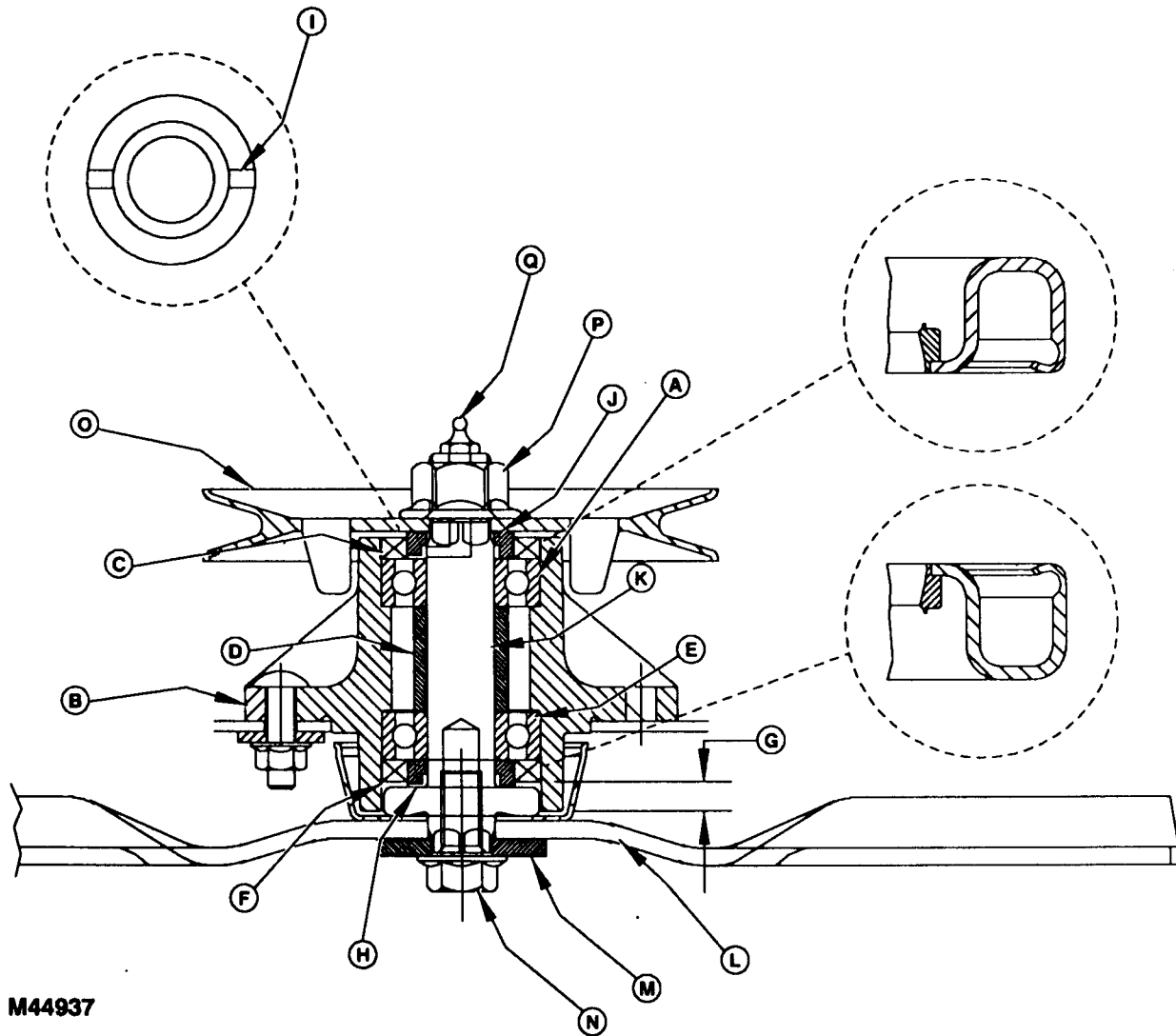

M44937

A—Upper Bearing
 B—Hub
 C—Upper Seal
 D—Spacer
 E—Lower Bearing

F—Lower Seal
 G—Seal Depth—7.8 mm (0.31 in.)
 H—Lower Seal Ring
 I—Grease Notch

J—Upper Seal Ring
 K—Spindle Shaft
 L—Blade
 M—Washer

N—Cap Screw
 O—Spindle Sheave
 P—Nut
 Q—Lubrication Fitting

-JUN-01/AUG91

M44937
80-05-5

MX,8010FS,A7G -19-23OCT95

ASSEMBLE 48-INCH SPINDLE

1. Press upper bearing (A) tight against spindle hub shoulder (B) using a 1-13/16 disk.
2. Press upper seal (C) with lip towards bearing, tight against bearing using a 1-13/16 disk.
3. Install upper seal ring (D), with grease notch (E) towards bearing, inside seal lip.

A—Upper Bearing
 B—Spindle Hub Shoulder
 C—Upper Seal
 D—Upper Seal Ring
 E—Grease Notch



MX,8010FS,A7B -19-23OCT95

-UN-20AUG91
 M44949

-UN-20AUG91
 M44950

4. Install spacer (B).

IMPORTANT: Support both the inner and outer bearing races when pressing in bearings or shaft.

DO NOT press lower bearing (C) tight against hub shoulder (A). The bearing and seal must be installed to a specific dimension for proper sealing of spindle.

5. Press lower bearing (C) in hub using a 1-13/16 disk.

6. Press lower seal (D) with lip towards bearing using a 1-13/16 disk until seal is **7.8 mm (0.31 in.) below hub flange (F)**.

7. Install lower seal ring (E), with grease notch away from bearing, inside seal lip.

A—Spindle Hub Shoulder
 B—Spacer
 C—Lower Bearing
 D—Lower Seal
 E—Lower Seal Ring
 F—Hub Flange

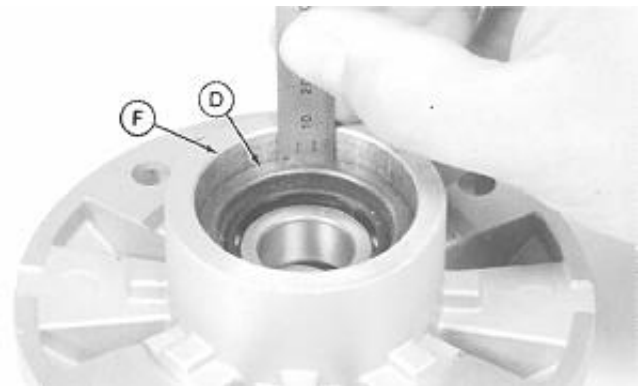
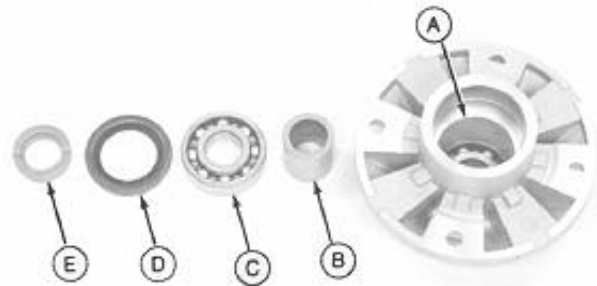

MX,8010FS,A7C -19-23OCT95

-UN-20AUG91
 M44951

-UN-20AUG91
 M44952

62510

8. Align spacer (G) and press spindle shaft (J) into hub assembly.

IMPORTANT: On early model decks **DO NOT** install hexagon end of spindle shaft in a vise to install spindle sheave nut. The hexagon end of spindle shaft will be damaged resulting in improper blade operation.

9. Install blade (K), washer (L), and cap screw (M) on spindle shaft. On early model decks, make sure that the hexagon shaped hole in washer is in alignment with hexagon portion of spindle. Tighten cap screw to **122 N·m (90 lb-ft)**.

IMPORTANT: Make sure that the hexagon shaped hole in spindle sheave is in alignment with hexagon portion of spindle shaft.

10. Hold blade with a soft jaw vise or if spindle is in deck, with a block of wood. Install spindle sheave (B), nut (A), and lubrication fitting (I). Tighten nut to **163 N·m (120 lb-ft)**.

11. Remove cap screw, washer and blade.

12. Lubricate spindle with MPG-2® Polymer Multipurpose Grease or equivalent at lubrication fitting.

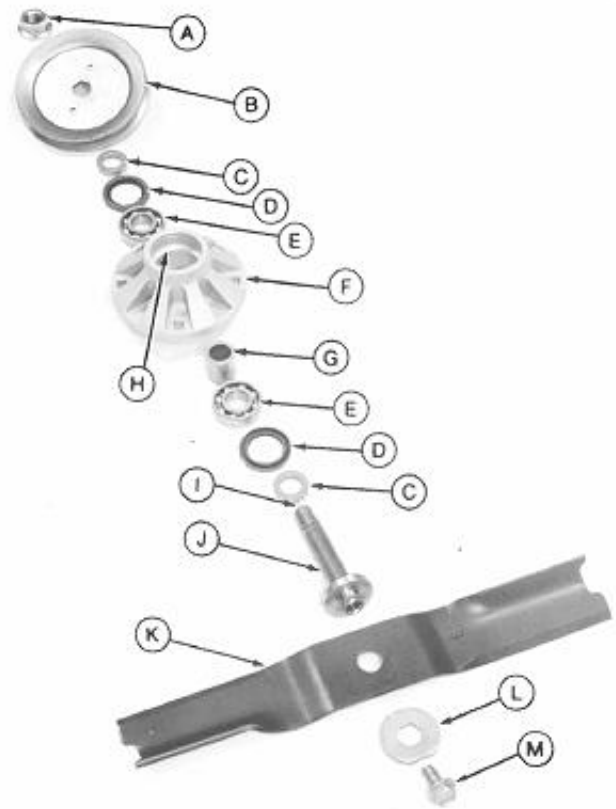

- A—Nut
- B—Spindle Sheave
- C—Seal Ring (2 used)
- D—Seal (2 used)
- E—Bearing (2 used)
- F—Spindle Hub
- G—Spacer
- H—Spindle Hub Shoulder
- I—Lubrication Fitting
- J—Spindle Shaft
- K—Blade
- L—Washer
- M—Cap Screw

MX,8010FS,A7D -19-23OCT95

M44948 -JUN-20AUG91

80
05
7

REPAIR DECK LIFT LINKAGE—F510

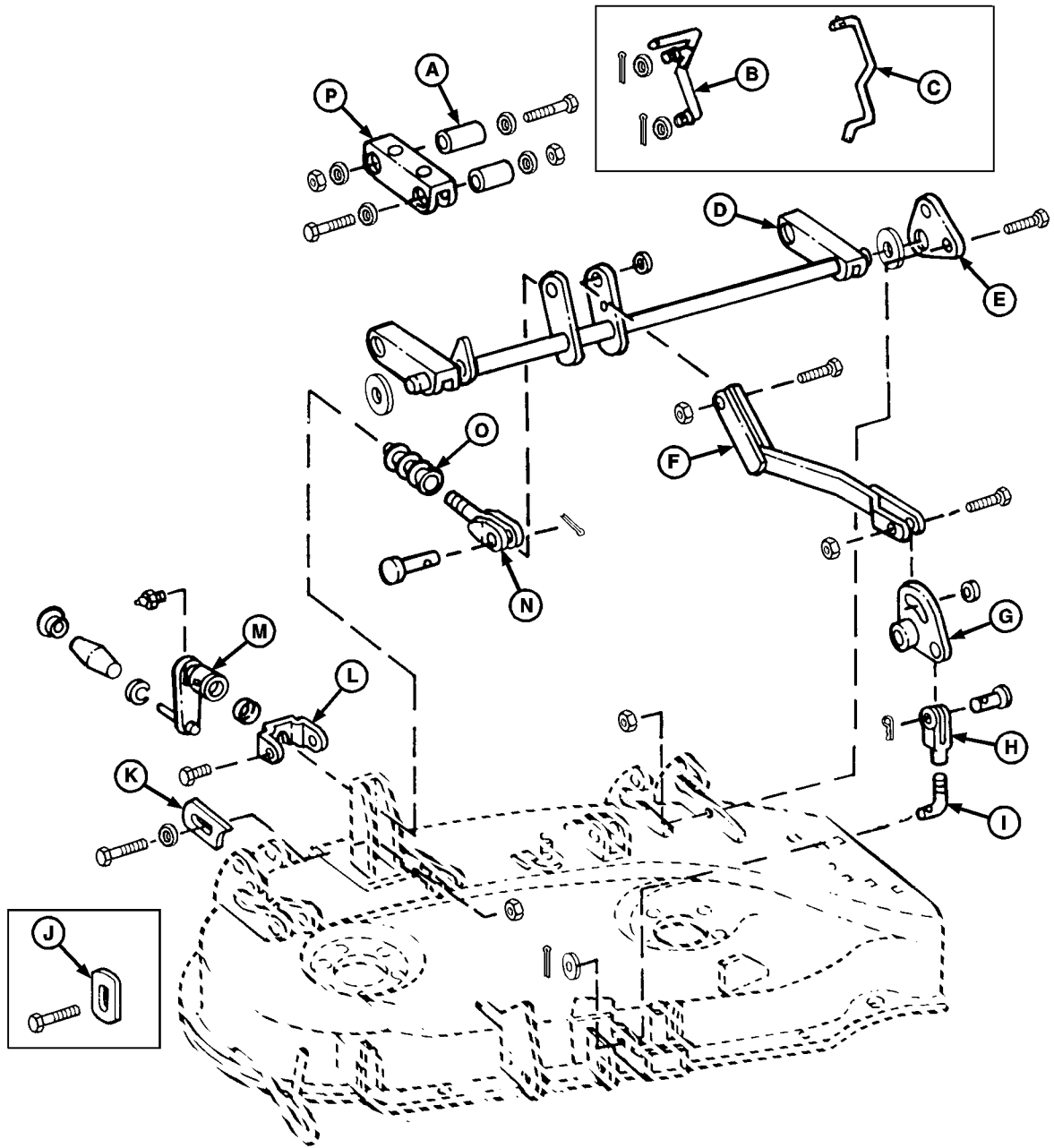

- | | | | |
|-----------------------------------|------------|-----------------------|-----------------------|
| A—Bushing | E—Retainer | I—Hook Bolt | M—Handle |
| B—Indicator (Early Models) | F—Strap | J—Stop (Early Models) | N—Yoke |
| C—Indicator (Intermediate Models) | G—Plate | K—Stop | O—Boot (S.N. —140000) |
| D—Shaft | H—Yoke | L—Retainer | P—Lift Arm |

Replace worn bushings (A) or torn boot (O), if equipped. Replace damaged parts.

REPAIR DECK LIFT LINKAGE—F525

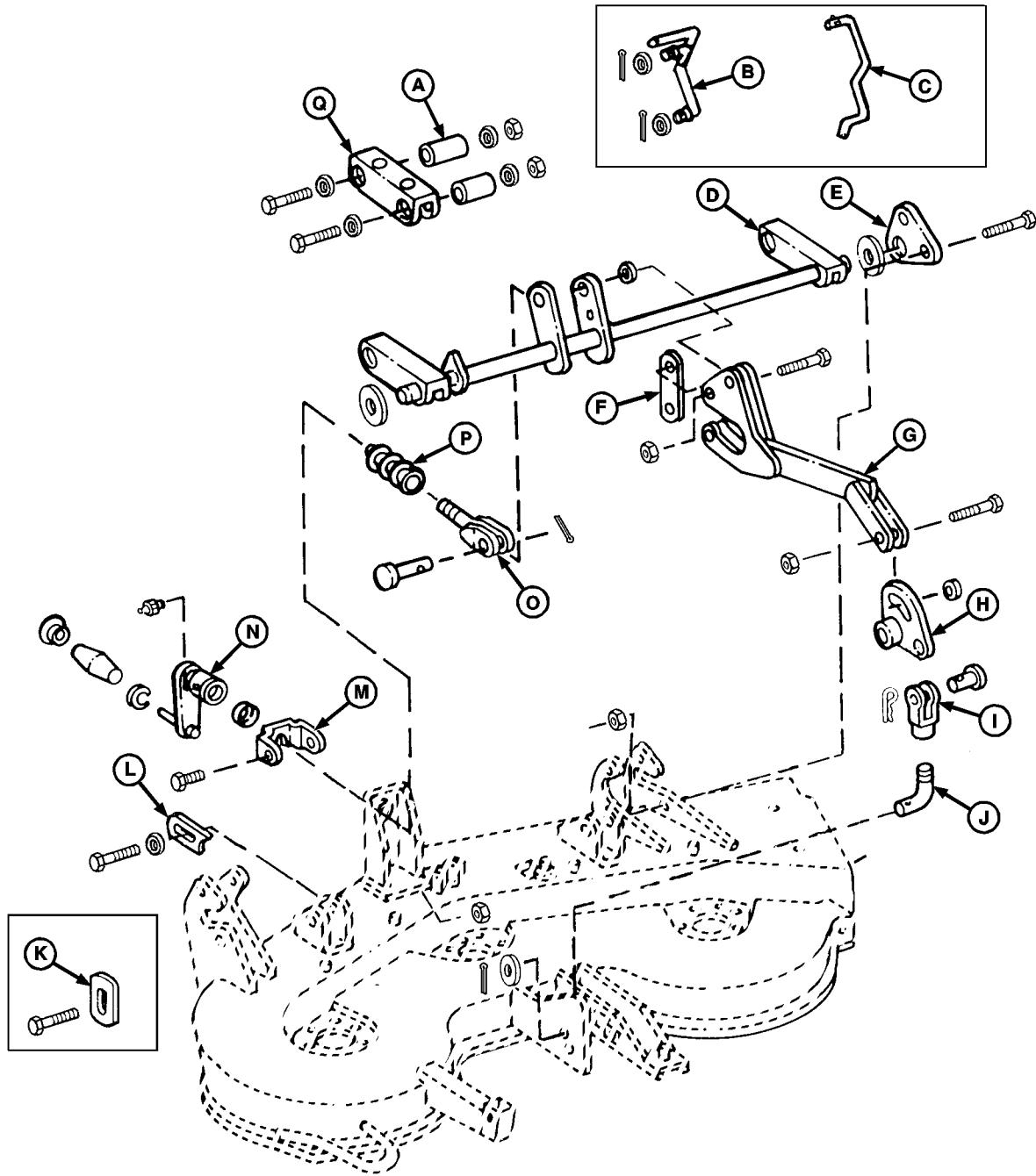

- | | | | |
|-----------------------------------|---------------|-----------------------|----------------------|
| A—Bushing | E—Retainer | J—Hook Bolt | N—Handle |
| B—Indicator (Early Models) | F—Strap Brace | K—Stop (Early Models) | O—Yoke |
| C—Indicator (Intermediate Models) | G—Strap | L—Stop | P—Boot (S.N. —10000) |
| D—Shaft | H—Plate | M—Retainer | Q—Lift Arm |
| | I—Yoke | | |

Replace worn bushings (A) or torn boot (P), if equipped. Replace damaged parts.

MX.7005CL.A5 -19-23OCT95

REPAIR PIVOTING JACKSHEAVE ASSEMBLY—F510 (S.N. 130001—)

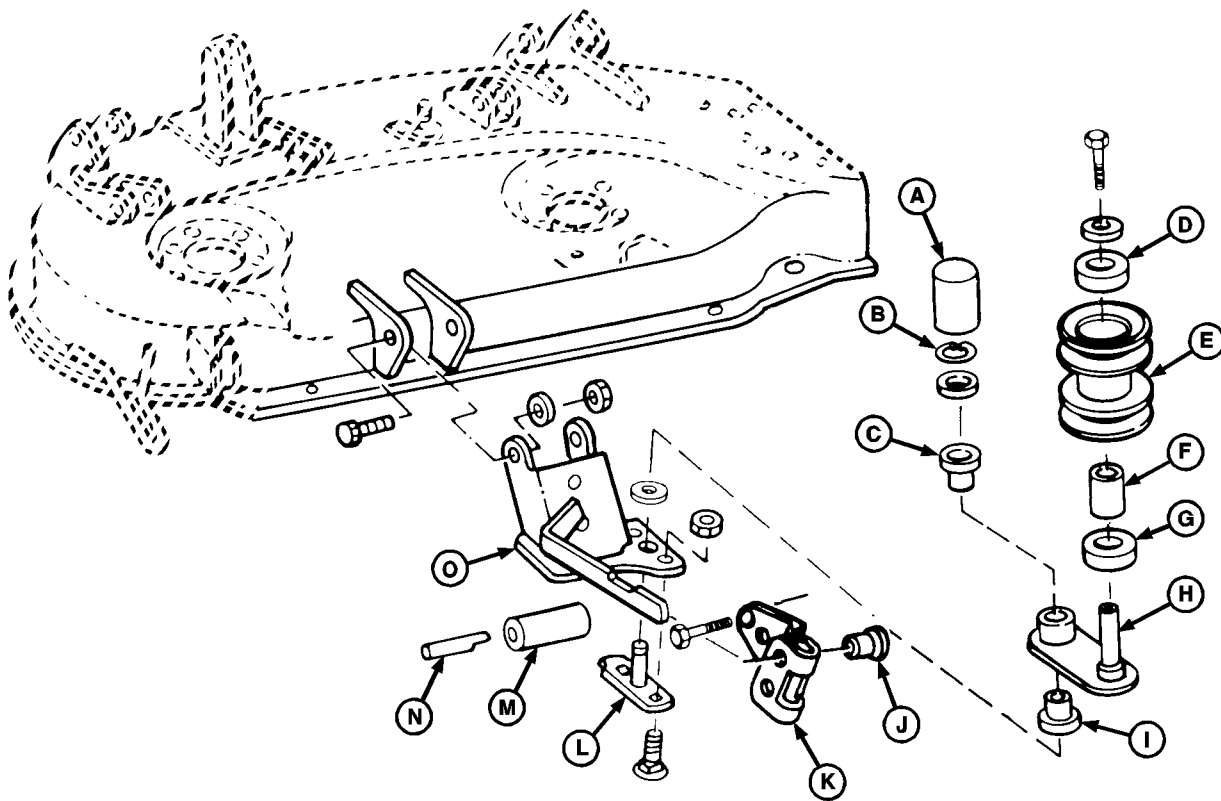

A—Cap
B—Snap Ring
C—Bushing
D—Ball Bearing

E—Sheave
F—Spacer
G—Ball Bearing
H—Arm

I—Bushing
J—Pin (2 used)
K—Bracket
L—Pivot

M—Roller
N—Pin
O—Bracket

NOTE: Remove bearings (D) and (G) only if being replaced.

1. Jack sheave ball bearings (D) and (G) are seated against a shoulder.
2. Using a brass drift, drive spacer (F) against lower bearing (G) to remove. Use a punch to remove upper bearing (D).

3. Replace worn bushings (C) and (I).
4. Inspect parts for wear or damage. Replace damaged parts.
5. Press bearings (D) and (G) until seated against shoulders in sheave.

80
05
10

M81629 -JUN-12/MAY95

MX,8010FS,A7E -19-23OCT95

REPAIR PIVOTING JACKSHEAVE ASSEMBLY—F525 (S.N. 130001—)

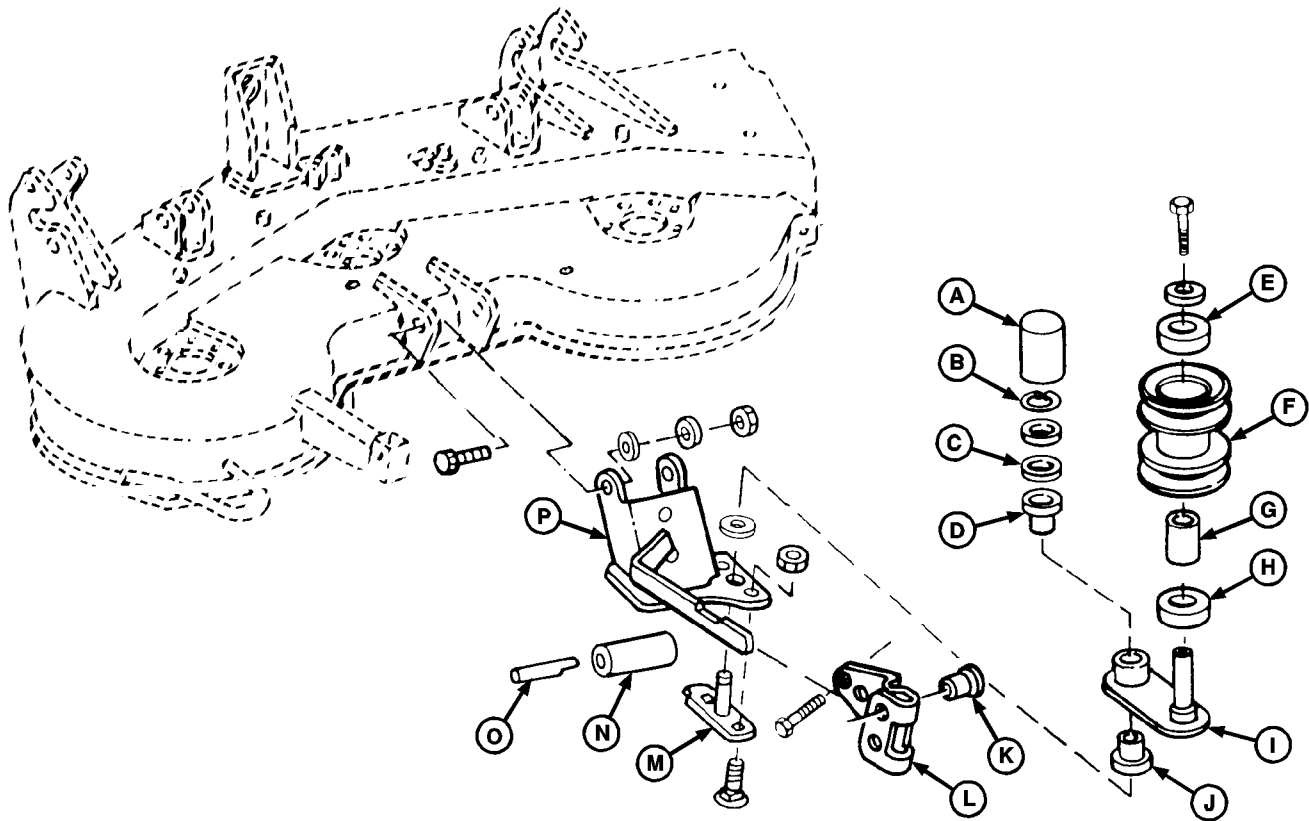

- | | | | |
|-------------|----------------|----------------|-----------|
| A—Cap | E—Ball Bearing | I—Arm | M—Pivot |
| B—Snap Ring | F—Sheave | J—Bushing | N—Roller |
| C—Packing | G—Spacer | K—Pin (2 used) | O—Pin |
| D—Bushing | H—Ball Bearing | L—Bracket | P—Bracket |

NOTE: Remove bearings (E) and (H) only if being replaced.

1. Jack sheave ball bearings (E) and (H) are seated against a shoulder.
2. Using a brass drift, drive spacer (G) against lower bearing (H) to remove. Use a punch to remove upper bearing (E).
3. Replace worn bushings (D) and (J).
4. Inspect parts for wear or damage. Replace damaged parts.
5. Press bearings (E) and (H) until seated against shoulders in sheave.

MB1630 -JUN-12/MAY95

80
05
11

MX,8010FS,A7F -19-23OCT95

80
05
12

REMOVE AND INSTALL BELT

1. Park mower on hard, level surface.
2. Crank mower to highest position.
3. Remove two pins (A) holding cable end.

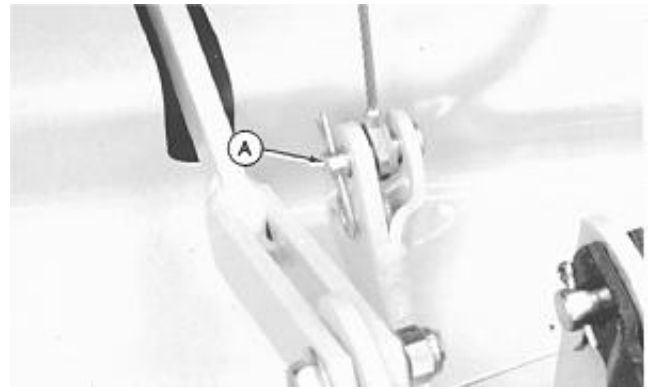

MX,5005CL,A2 -19-04MAY92

M62286
-UN-15MAR89

4. Crank mower all the way down.
5. Pivot handle (A) to the left to release belt tension.
6. Remove spring from handle.
7. Reach under frame behind drive wheel to remove belt from engine sheave.



MX,SECL,AC -19-29JUL92

M62282
-UN-15MAR89

8. Remove ring pins from push arms:
 - Lift end of ring pin (A) to remove it.
 - Remove drilled pin.



MX,SECL,AD -19-23OCT95

M62292
-UN-15MAR89

9. Remove spring pin (A) and long pin.
10. Remove center arm bushing (B) from push arm.



MX,SECL,AF -19-29JUL92

M62280
-UN-09JUL92

Blade Drive Belt/Remove and Install Belts

11. Use straps (A) or ropes to hold push arms up.
12. Pull mower away from Front Mower.



MX,SECL,AE -19-29JUL92

M62287 -UN-15MAR89

13. Remove spring locking pin and drilled pin (A) holding center arm to yoke.
14. Pivot mower center arm all the way forward.



(SN -130000)



(SN 130001-)

MX,SECL,AGA -19-23OCT95

M62289 -UN-15MAR89

M81628 -UN-12MAY95

15. Remove belt shields:
 - F510 Mower: Remove six screws (A).
 - F525 Mower: Loosen six screws.

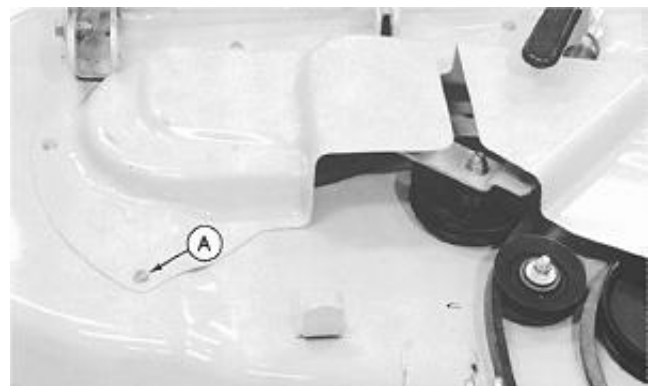

MX,SECL,AH -19-23OCT95

M62285 -UN-15MAR89

80
10
2

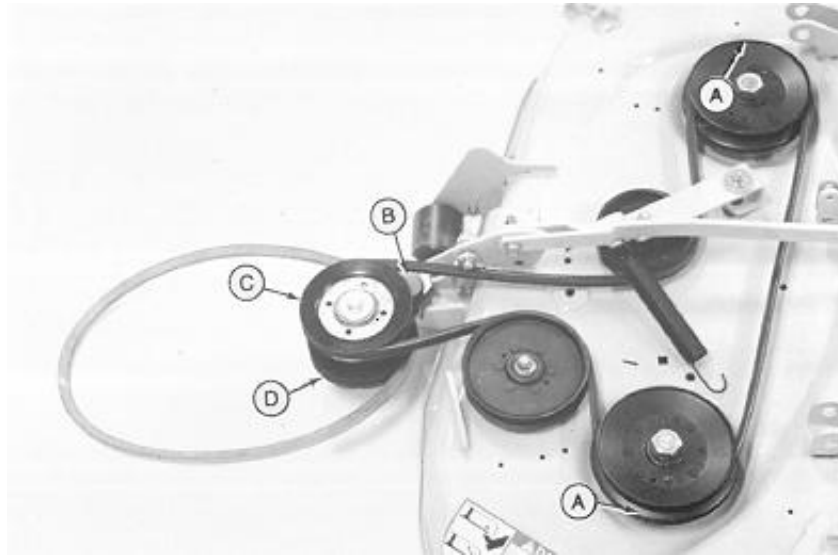

M62697
-JUN-17AUG89

F510 Mower (S.N. —130000)

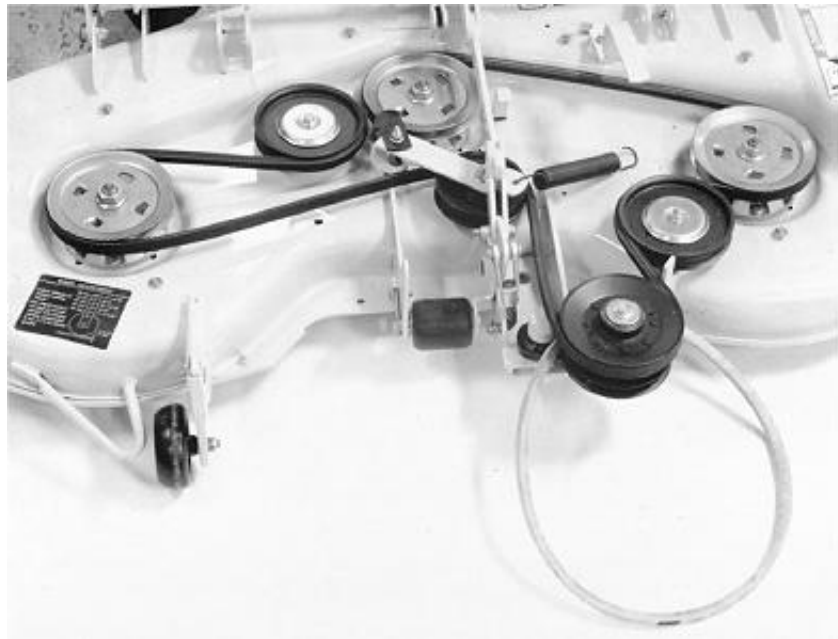

M73240
-JUN-05SEP90

F525 Mower (S.N. —130000)

NOTE: Steps 16—20 are for mowers (S.N. —130000) only. See Steps 21—24 for mowers (S.N. 130001—) or for early mowers that have been updated.

16. Remove belts.

17. Install short belt first, then install long belt as shown.

18. F510 Mower: Tape belt in two places (A) to keep belt in place while installing shield.

19. Install and fasten belt shields:

- F510: Install and tighten six screws.
- F525: Tighten six screws.

20. Fasten center arm to yoke at rear of mower.

Blade Drive Belt/Remove and Install Belts

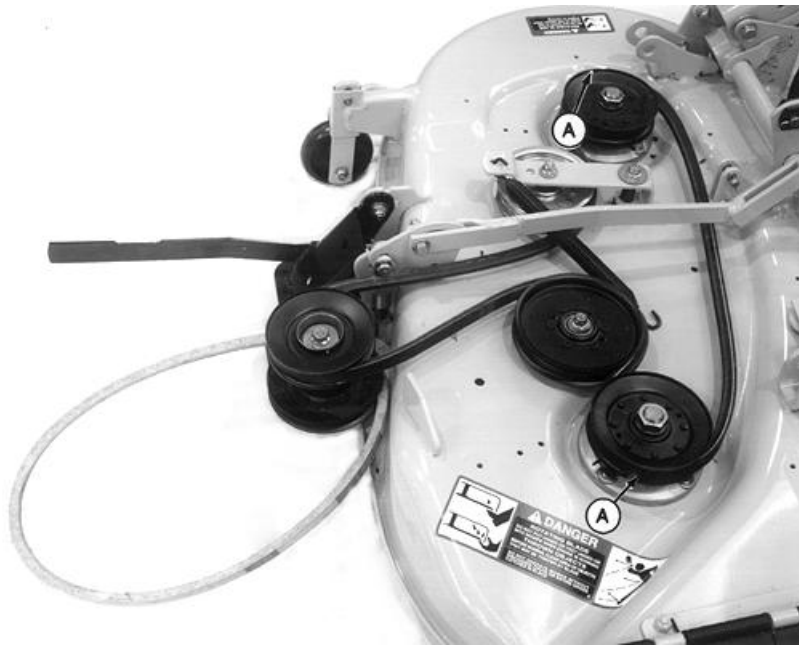

F510 Mower (S.N. 130001—)

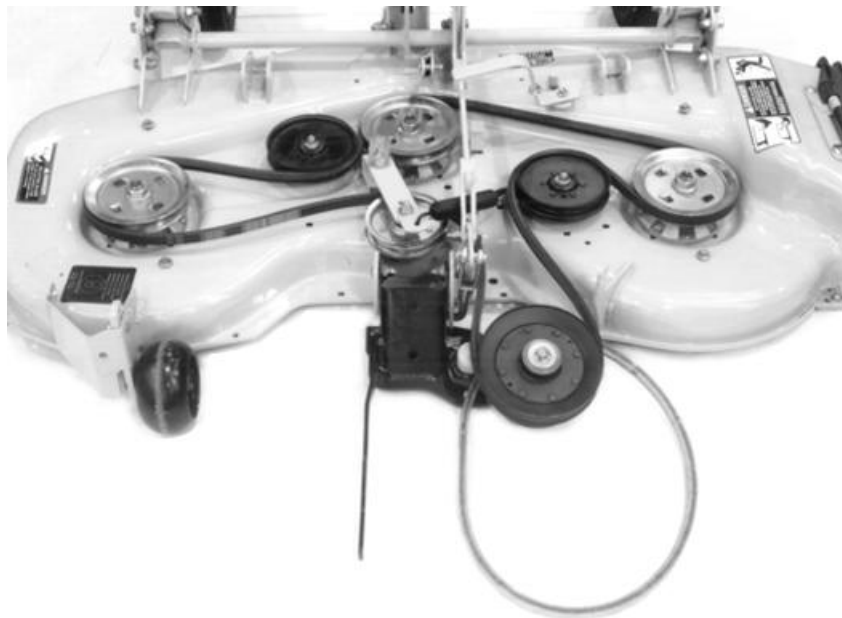

F525 Mower (S.N. 130001—)

M81638
-JUN-23JUN95

M81639
-JUN-23JUN95

80
10
4

21. Remove belts. Install long belt as shown.

22. F510 Mower: Tape belt in two places (A) to keep belt in place while installing shield.

23. Install and fasten belt shields:

- F510: Install and tighten six screws.
- F525: Tighten six screws.

24. Fasten center arm to yoke at rear of mower.

MX,SECL,AIA -19-23OCT95

OTHER MATERIAL

Number	Name	Use
TY6240	John Deere Multipurpose Grease	Lubricate drive shaft and caster wheel.
	John Deere Chain Lube	Lubricate chain.

MX,8015CL,A -19-23OCT95

80
15
1

REPAIR SHOWTHROWER LIFT LINKAGE

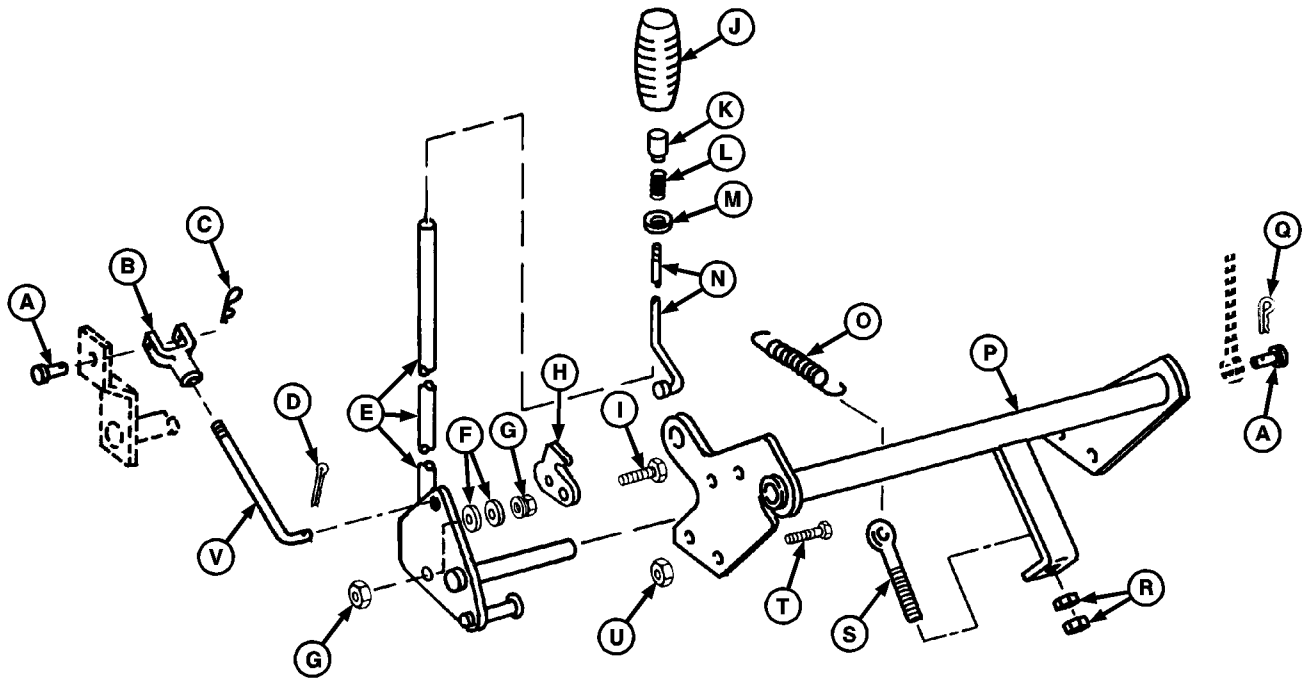

- | | | | |
|-----------------------|-----------------------|----------------------|--------------------|
| A—Pin (2 used) | G—Flange Nut (2 used) | M—Washer (3 used) | R—Nut (2 used) |
| B—Yoke | H—Latch | N—Lift Handle Rod | S—Eyebolt |
| C—Spring Locking Pin | I—Screw | O—Spring | T—Screw |
| D—Cotter Pin | J—Grip | P—Support | U—Locknut (2 used) |
| E—Housing Lift Handle | K—Release Lever Pin | Q—Spring Locking Pin | V—Rod Lift Bolt |
| F—Washer (2 used) | L—Spring | | |

1. Inspect parts for wear or damage. Replace damaged parts as necessary.

2. Apply John Deere Multipurpose Grease to housing lift handle shaft (E).

REPAIR SNOWTHROWER LIFT ASSEMBLY

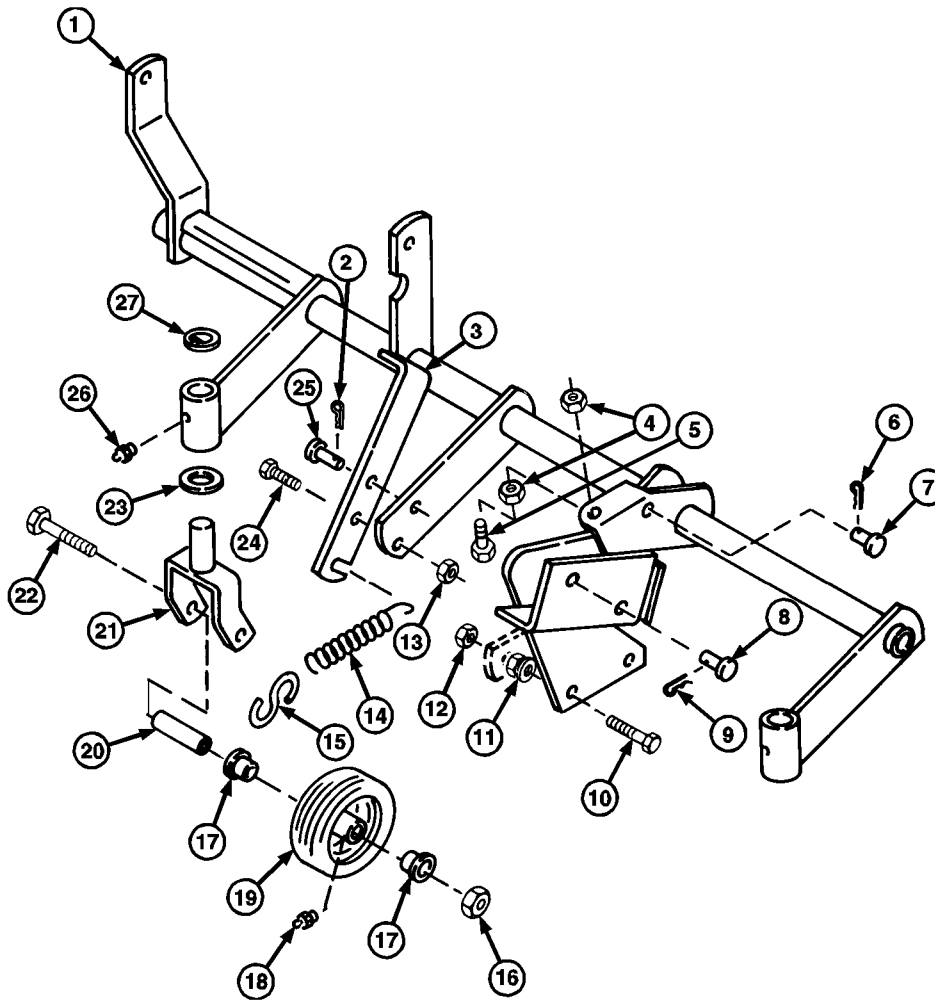

- | | | | |
|----------------------|-------------------------------|---------------------------------|---------------------------------|
| 1—Rockshaft | 9—Spring Locking Pin (4 used) | 16—Lock Nut (2 used) | 22—Cap Screw (2 used) |
| 2—Spring Locking Pin | 10—Screw (2 used) | 17—Bearing (4 used) | 23—Washer (2 used) |
| 3—Adjusting Strap | 11—Nut (2 used) | 18—Lubrication Fitting (2 used) | 24—Screw |
| 4—Nut (2 used) | 12—Lock Nut (2 used) | 19—Wheel (2 used) | 25—Pin |
| 5—Cap Screw | 13—Lock Nut | 20—Bushing (2 used) | 26—Lubrication Fitting (2 used) |
| 6—Spring Locking Pin | 14—Spring | 21—Arm (2 used) | 27—Snap Ring (2 used) |
| 7—Pin | 15—Hook | | |
| 8—Pin (4 used) | | | |

1. Replace bearings (17) and bushings (20) if worn or damaged.

2. Apply John Deere Multipurpose grease to lubrication fittings (18) and (26).

3. Inspect parts for wear or damage. Replace damaged parts as necessary.

4. Adjust upstop (4) and (5). (See Upstop Adjustment in Section 280, Group 15.)

REPAIR SNOWTHROWER DRIVE SHAFT ASSEMBLY

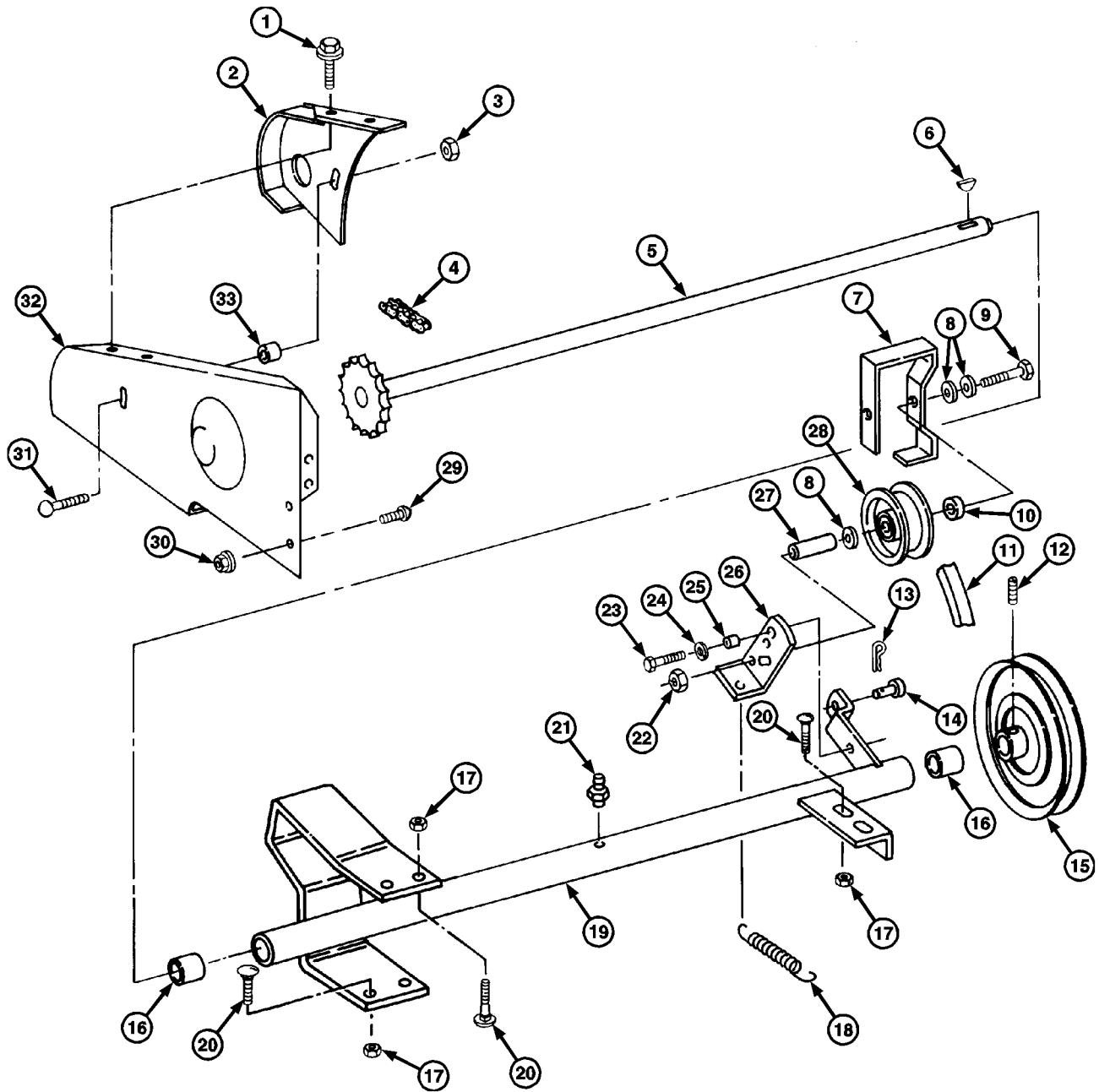

- | | | | |
|-------------------|-----------------------|------------------------|------------------|
| 1—Screw | 10—Bushing | 18—Spring | 26—Bracket |
| 2—Guard | 11—Belt | 19—Housing | 27—Spacer |
| 3—Nut | 12—Set Screw | 20—Bolt (6 used) | 28—Idler |
| 4—Chain | 13—Spring Locking Pin | 21—Lubrication Fitting | 29—Bolt (2 used) |
| 5—Shaft | 14—Pin | 22—Lock Nut | 30—Nut (2 used) |
| 6—Key | 15—Sheave | 23—Screw | 31—Bolt |
| 7—Retainer | 16—Bushing (2 used) | 24—Washer | 32—Guard |
| 8—Washer (3 used) | 17—Nut (6 used) | 25—Washer | 33—Spacer |
| 9—Cap Screw | | | |

80
15
4

M58386 -UN-09AUG95

MX,8015CLD -19-23OCT95

38-Inch Snowthrower/Snowthrower Drive Shaft Assembly

1. Replace bushings (16) if worn or damaged.
2. Inspect chain (4) for wear. Replace if necessary.
3. Inspect belt (11) for signs of wear, stretching or damage. Replace as needed.
4. Apply John Deere Multipurpose Grease to lubrication fitting (21).
5. Apply John Deere TY6240 chain lube or equivalent to chain (40).
6. Inspect parts for wear or damage. Replace damaged parts as necessary.
7. Adjust chain tension. (See Chain Tension Adjustment in Section 280, Group 15.)

MX,8015CL,D1 -19-23OCT95

80
15
5

REPAIR SNOWTHROWER HOUSING ASSEMBLY

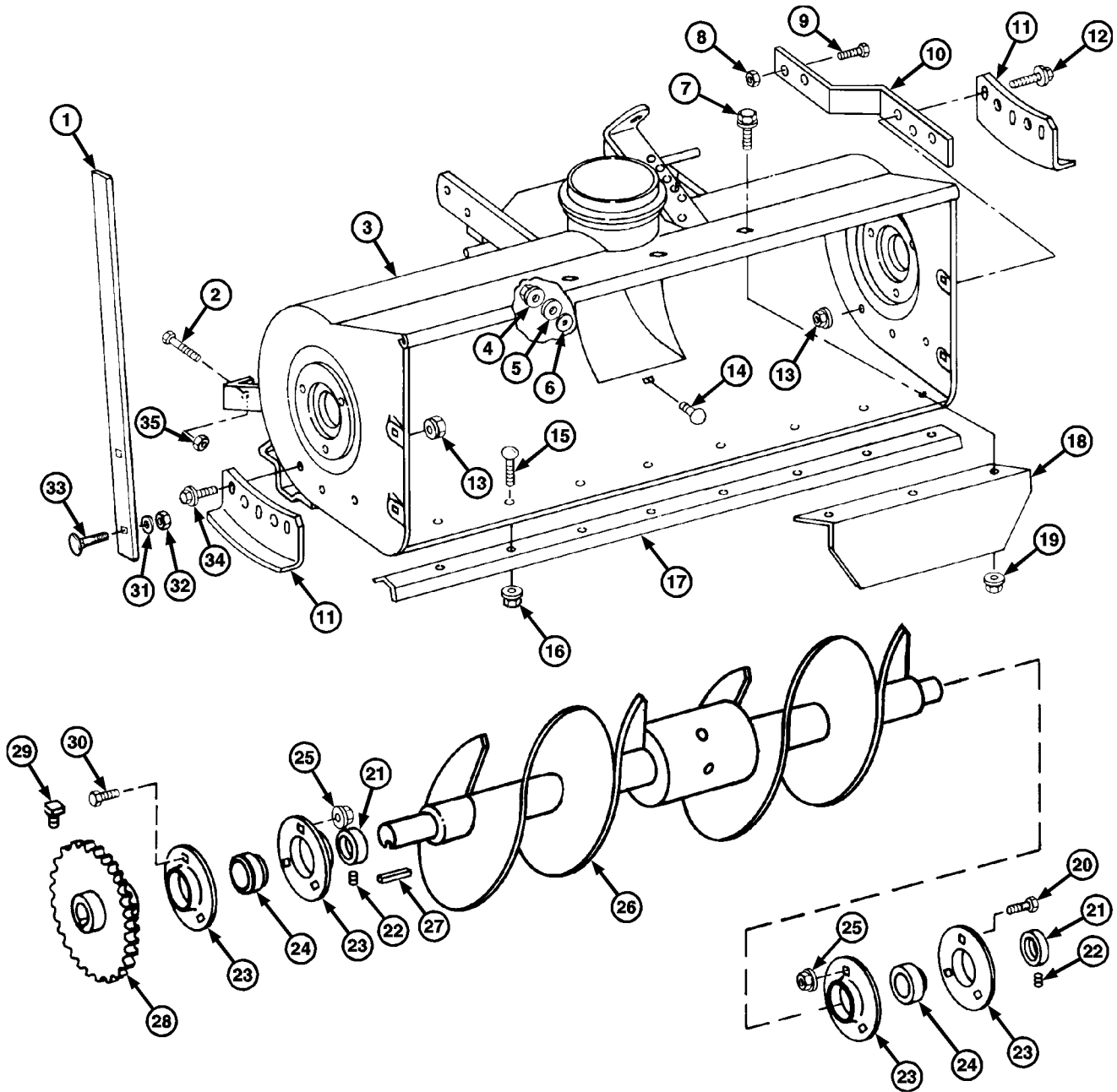

- | | | | |
|---------------------|--------------------|--------------------------------------|-------------------------|
| 1—Drift Blade | 11—Runner (2 used) | 20—Screw (6 used) | 27—Key |
| 2—Cap Screw | 12—Screw (3 used) | 21—Eccentric Locking Collar (2 used) | 28—Sprocket (40 tooth) |
| 3—Frame | 13—Nut (6 used) | 22—Set Screw (2 used) | 29—Set Screw |
| 4—Lock Nut | 14—Bolt | 23—Pressed Flange Housing (4 used) | 30—Screw (6 used) |
| 5—Washer | 15—Bolt (8 used) | 24—Ball Bearing (2 used) | 31—Lock Washer (2 used) |
| 6—Washer | 16—Nut (8 used) | 25—Nut (6 used) | 32—Nut (2 used) |
| 7—Screw (3 used) | 17—Blade | 26—Rotor | 33—Bolt (2 used) |
| 8—Lock Nut (2 used) | 18—Angle | | 34—Screw (3 used) |
| 9—Screw (2 used) | 19—Nut (3 used) | | 35—Nut |
| 10—Lift Arm | | | |

80
15
6

M83021 -UN-09AUG95

38-Inch Snowthrower/Snowthrower Housing Assembly

1. Inspect parts for wear or damage. Replace damaged parts as necessary.
2. Inspect blade (16). Reverse blade if edge is rough or worn. Replace blade if worn.
3. Adjust runners. (See Runner Adjustment in Section 280, Group 15.)

MX,8015CL,E1 -19-23OCT95

80
15
7

REPAIR SNOWBLOWER CHUTE ASSEMBLY

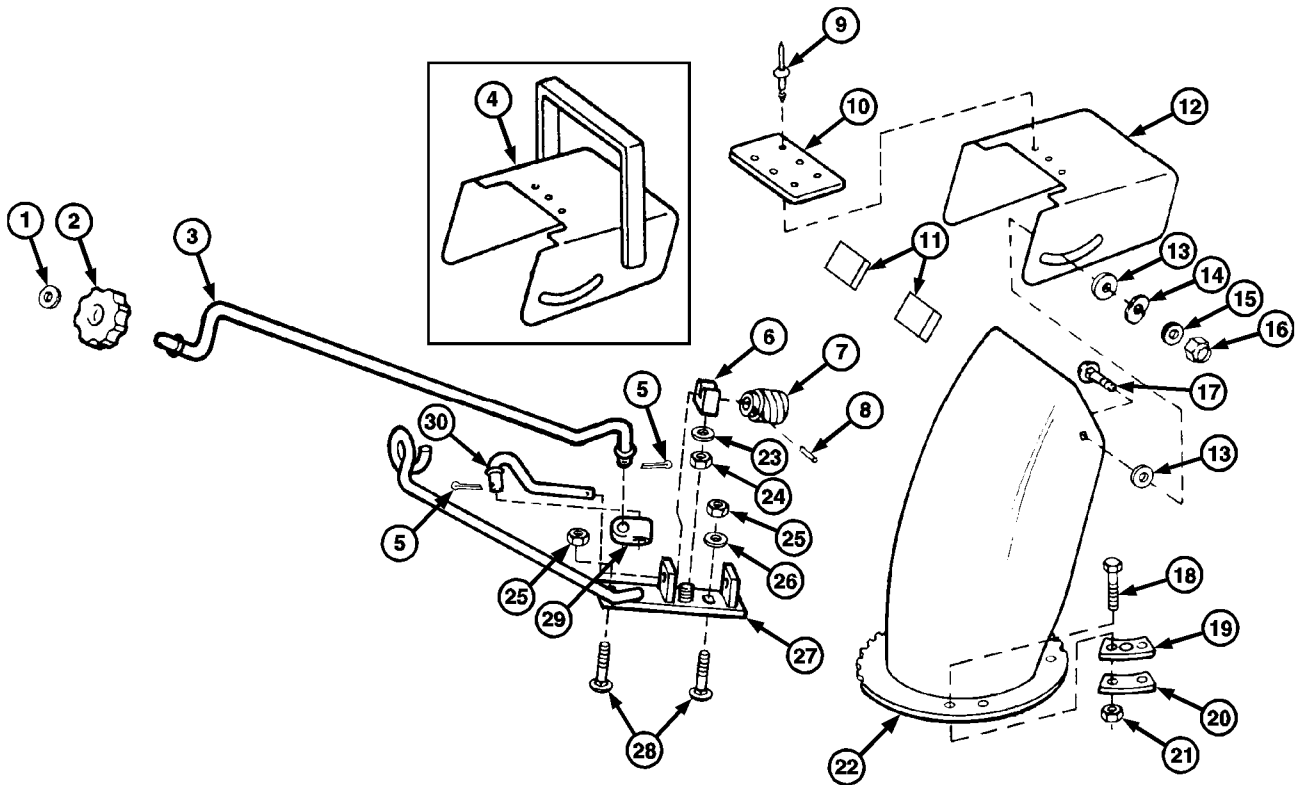

- | | | | |
|------------------------|-------------------------|-----------------------|--------------------------|
| 1—Thrust Washer | 9—Rivet (6 used) | 17—Screw | 24—Lock Nut |
| 2—Knob | 10—Hinge | 18—Cap Screw (6 used) | 25—Lock Nut (2 used) |
| 3—Rod | 11—Pad (2 used) | 19—Clip (3 used) | 26—Washer |
| 4—Spout (Later Models) | 12—Spout (Early Models) | 20—Clip (3 used) | 27—Bracket |
| 5—Cotter Pin (2 used) | 13—Washer (4 used) | 21—Lock Nut (6 used) | 28—Bolt (2 used) |
| 6—Retainer | 14—Wavy Washer (2 used) | 22—Chute | 29—Universal Joint Cross |
| 7—Worm Gear | 15—Washer (2 used) | 23—Washer | 30—Rod |
| 8—Spring Pin | 16—Lock Nut (2 used) | | |

1. Inspect parts for wear or damage. Replace damaged part as necessary.

2. Lubricate worm gear (7) and retainer (6) with John Deere multipurpose grease or equivalent.

3. Adjust Spout (4) or (12). (See Spout Adjustment in Section 280, Group 15.)

4. Adjust worm gear (7). (See Worm Gear Adjustment in Section 280, Group 15.)

MX,8015CL,F -19-23OCT95

80-15-8

MB3022 -JUN-09/AUG95

REPAIR OPTIONAL ELECTRIC SPOUT KIT

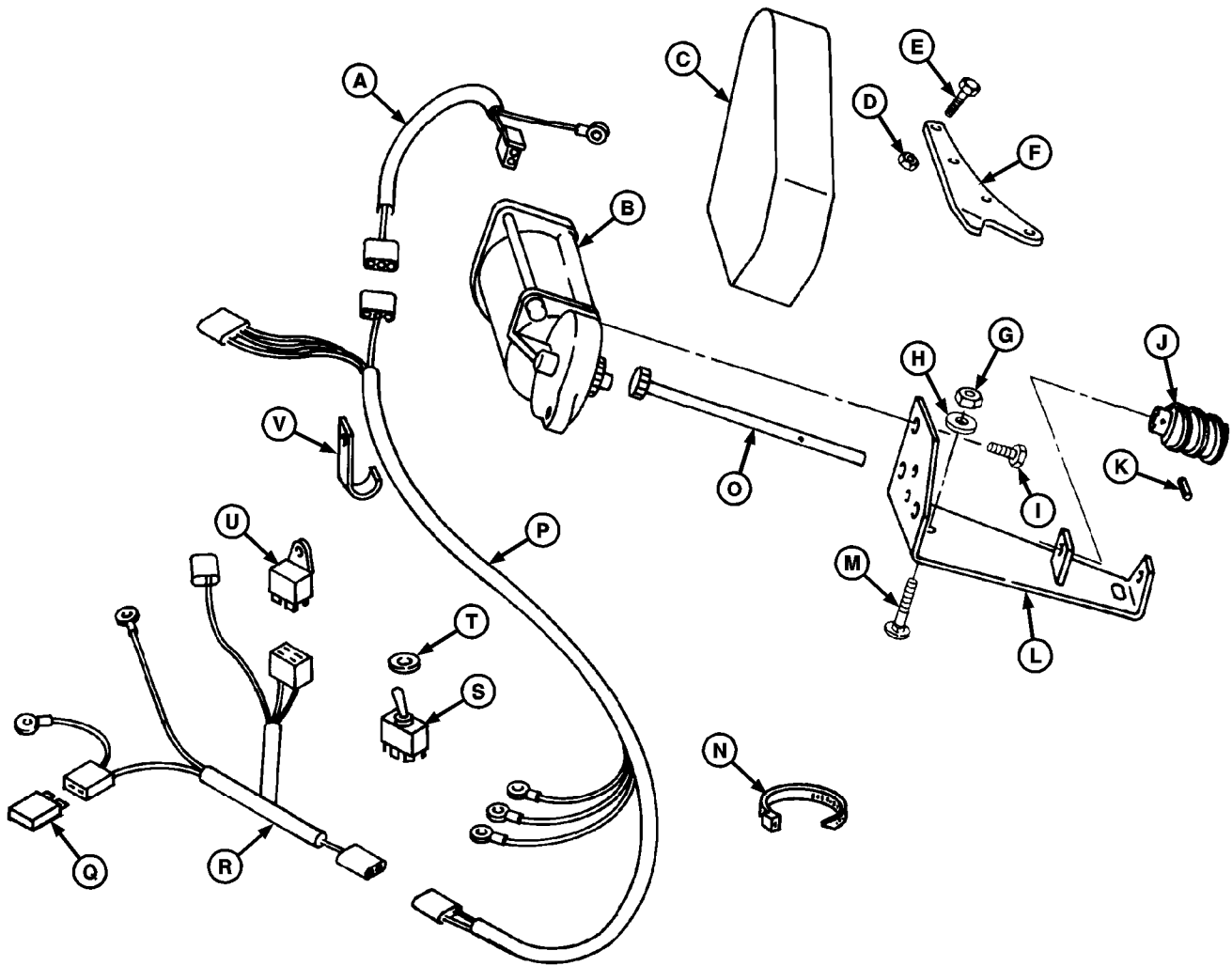

A—Wiring Harness
 B—Motor
 C—Shield
 D—Lock Nut (2 used)
 E—Cap Screw (2 used)
 F—Stop

G—Nut (2 used)
 H—Washer (2 used)
 I—Cap Screw (3 used)
 J—Worm Gear
 K—Spring Pin
 L—Bracket

M—Bolt (2 used)
 N—Tie Band (7 used)
 O—Rod
 P—Wiring Harness
 Q—Fuse

R—Wiring Harness
 S—Toggle Switch
 T—Nut
 U—Relay
 V—Clamp

1. Inspect parts for wear or damage. Replace damaged part as necessary.

2. Lubricate worm gear (J) with John Deere multipurpose grease or equivalent.

3. Adjust worm gear (J). (See Worm Gear Adjustment in Section 280, Group 15.)

MX,8015CL,G -19-23OCT95

M58389 -JUN-23AUG95

80
15
9

38-Inch Snowthrower/Optional Electric Spout Rotation Kit

80
15
10

REPAIR ROTOR (46-INCH MOWER DECK)

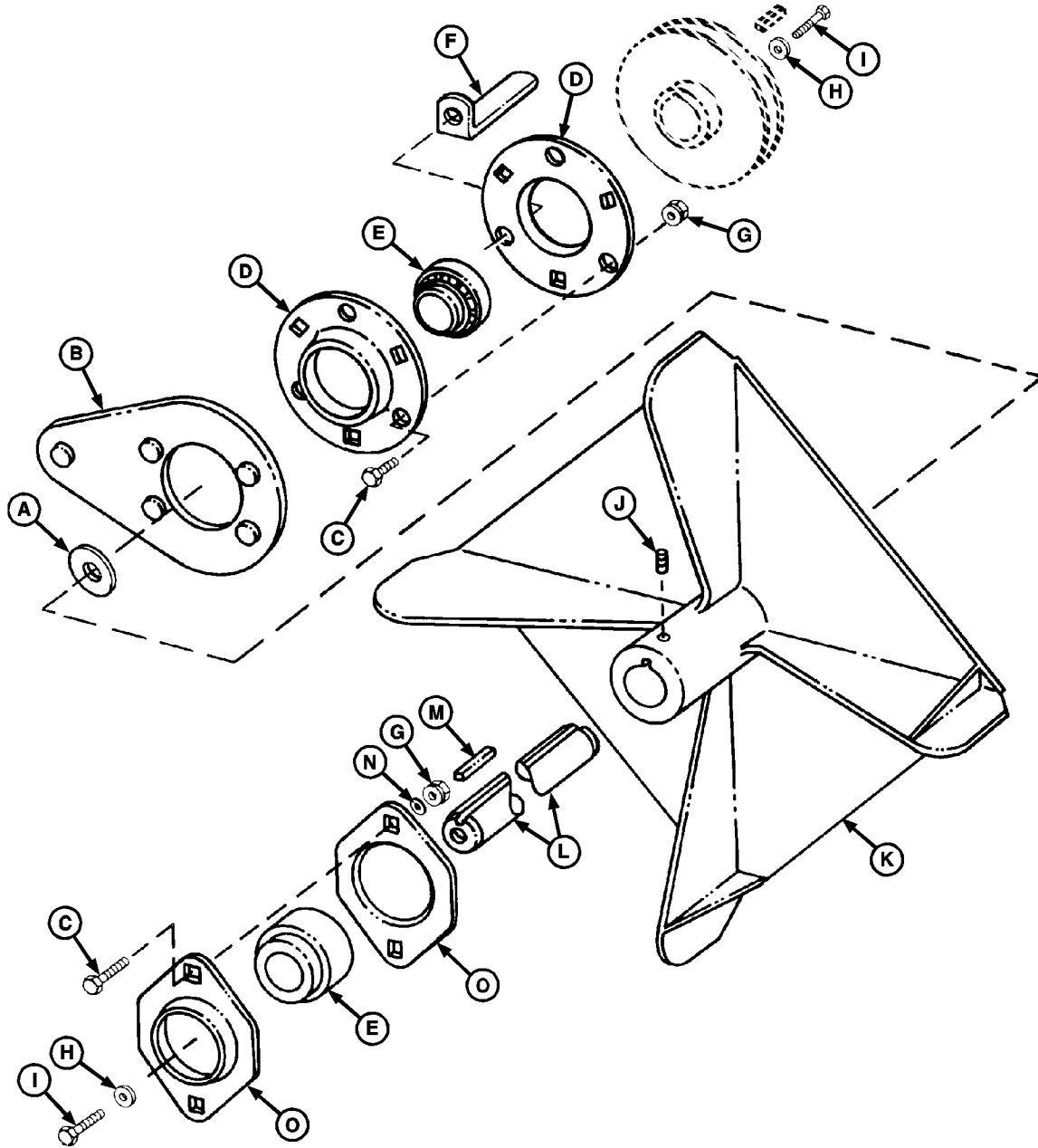

- | | | | |
|-----------------------------------|-------------------------|-----------------|-----------------------------------|
| A—Washer | E—Ball Bearing (2 used) | I—Bolt (2 used) | M—Key |
| B—Plate | F—Angle | J—Set Screw | N—Washer (2 used) |
| C—Screw (2 used) | G—Lock Nut (6 used) | K—Rotor | O—Pressed Flange Housing (2 used) |
| D—Pressed Flange Housing (2 used) | H—Washer (2 used) | L—Shaft | |

1. Inspect parts for wear or damage. Replace damaged part as necessary.

M83024 -UN-23AUG95

80-20-1

REPAIR ROTOR (48-INCH MOWER DECK)

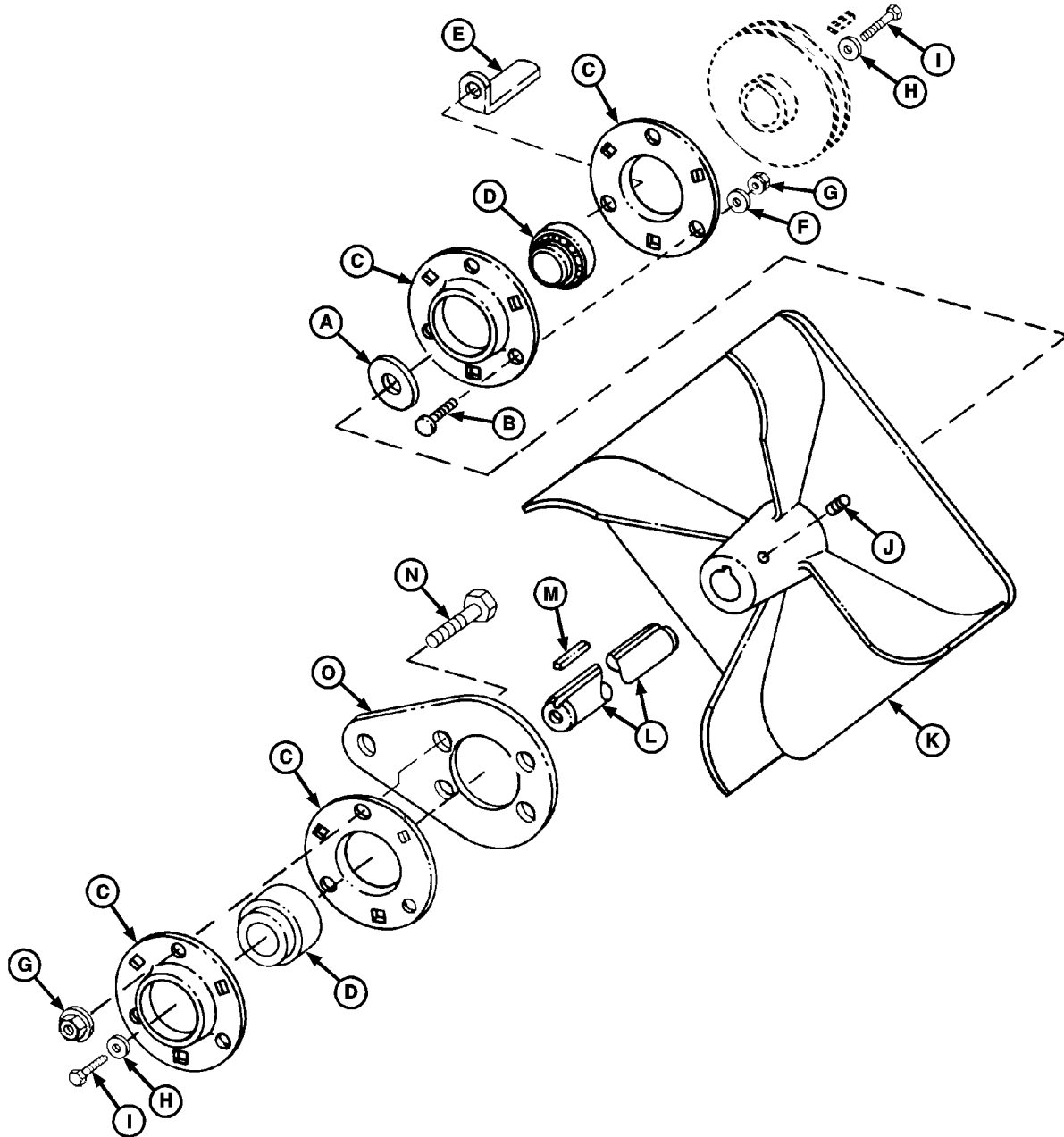

- | | | | |
|--------------------------------------|-------------------------|-------------------|------------------|
| A—Washer | D—Ball Bearing (2 used) | H—Washer (2 used) | L—Shaft |
| B—Bolt (3 used) | E—Angle | I—Bolt (2 used) | M—Key |
| C—Pressed Flange Housing
(4 used) | F—Washer (2 used) | J—Set Screw | N—Screw (4 used) |
| | G—Lock Nut (7 used) | K—Rotor | O—Plate |

1. Inspect parts for wear or damage. Replace damaged parts as necessary.

80
20
2

M83025 -UN-23AUG95

REPAIR JACKSHEAVE AND IDLERS (46-INCH MOWER DECK)

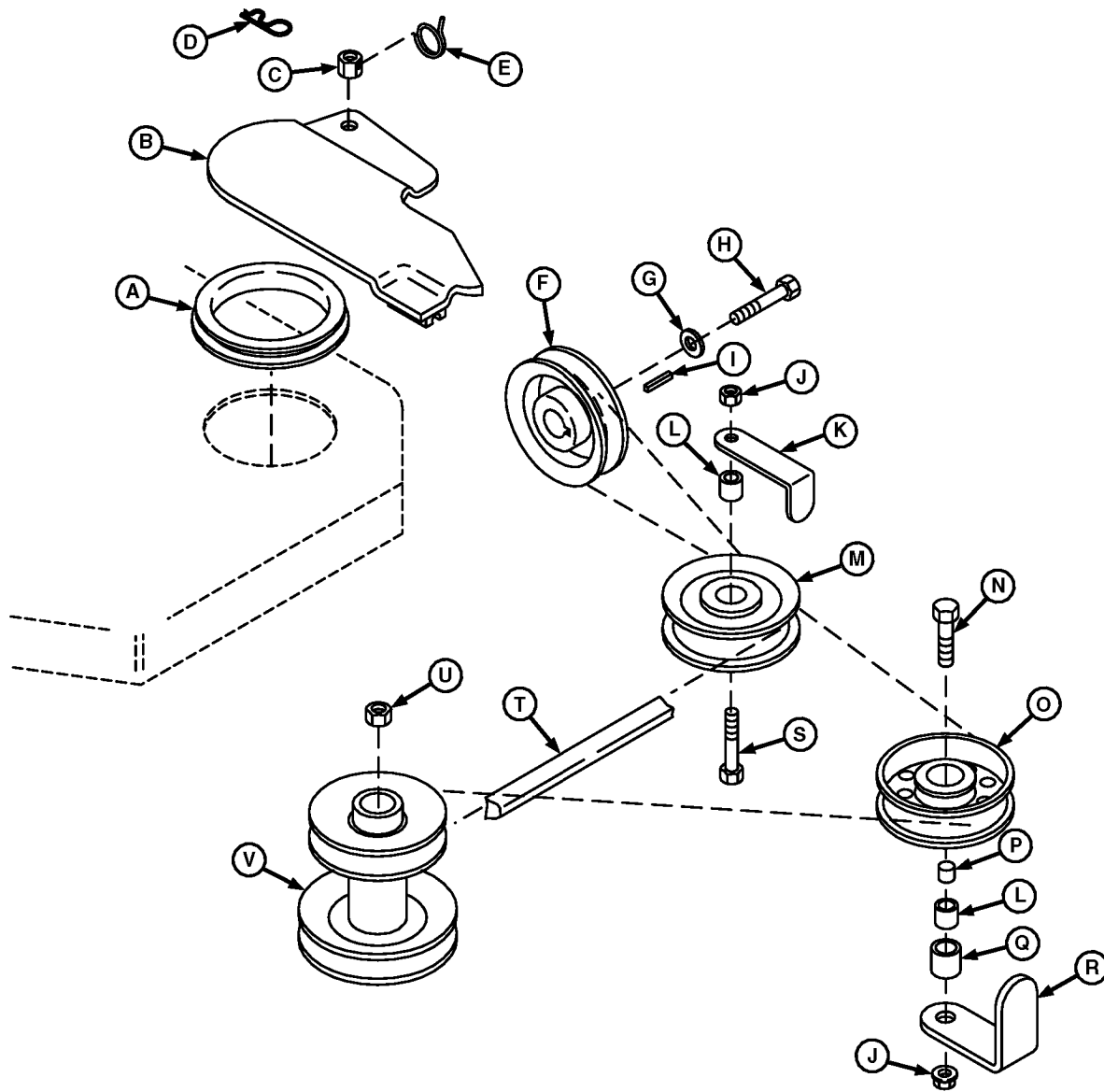

A—Channel
 B—Shield
 C—Nut
 D—Spring Locking Pin (Later Models)
 E—Ring (Early Models)

F—Sheave
 G—Washer
 H—Bolt
 I—Key
 J—Lock Nut (2 used)
 K—Bracket

L—Bushing (2 used)
 M—Idler
 N—Cap Screw
 O—Idler
 P—Bushing
 Q—Spacer

R—Angle
 S—Cap Screw
 T—Belt
 U—Nut
 V—Sheave

1. Inspect parts for wear or damage. Replace damaged parts as necessary.

2. Inspect belt (T) for sign of wear or stretching. Replace if necessary.

M83027 -UN-25AUG95

80
20
3

REPAIR JACKSHEAVE AND IDLERS (48-INCH MOWER DECK)

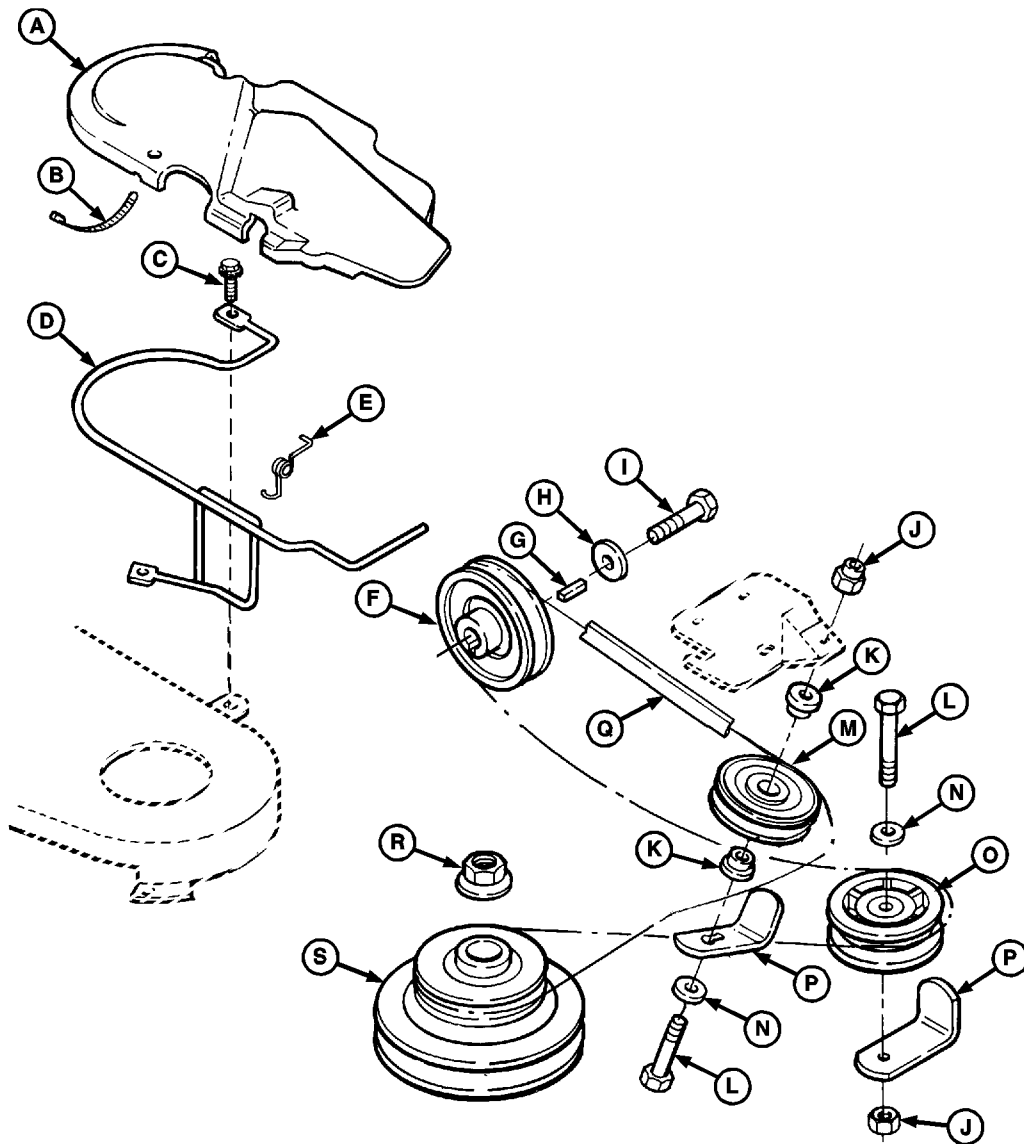

A—Shield
 B—Tie Wrap
 C—Screw
 D—Support
 E—Torsion Spring

F—Sheave
 G—Key
 H—Washer
 I—Bolt
 J—Lock Nut (2 used)

K—Bushing (2 used)
 L—Cap Screw (2 used)
 M—Sheave
 N—Washer (12 used)
 O—Idler

P—Bracket (2 used)
 Q—Belt
 R—Flange Nut
 S—Sheave

1. Inspect parts for wear or damage. Replace damaged parts as necessary.

2. Inspect belt (Q) for sign of wear or stretching. Replace if necessary.

REPAIR BLOWER HOUSING (46-INCH MOWER DECK)

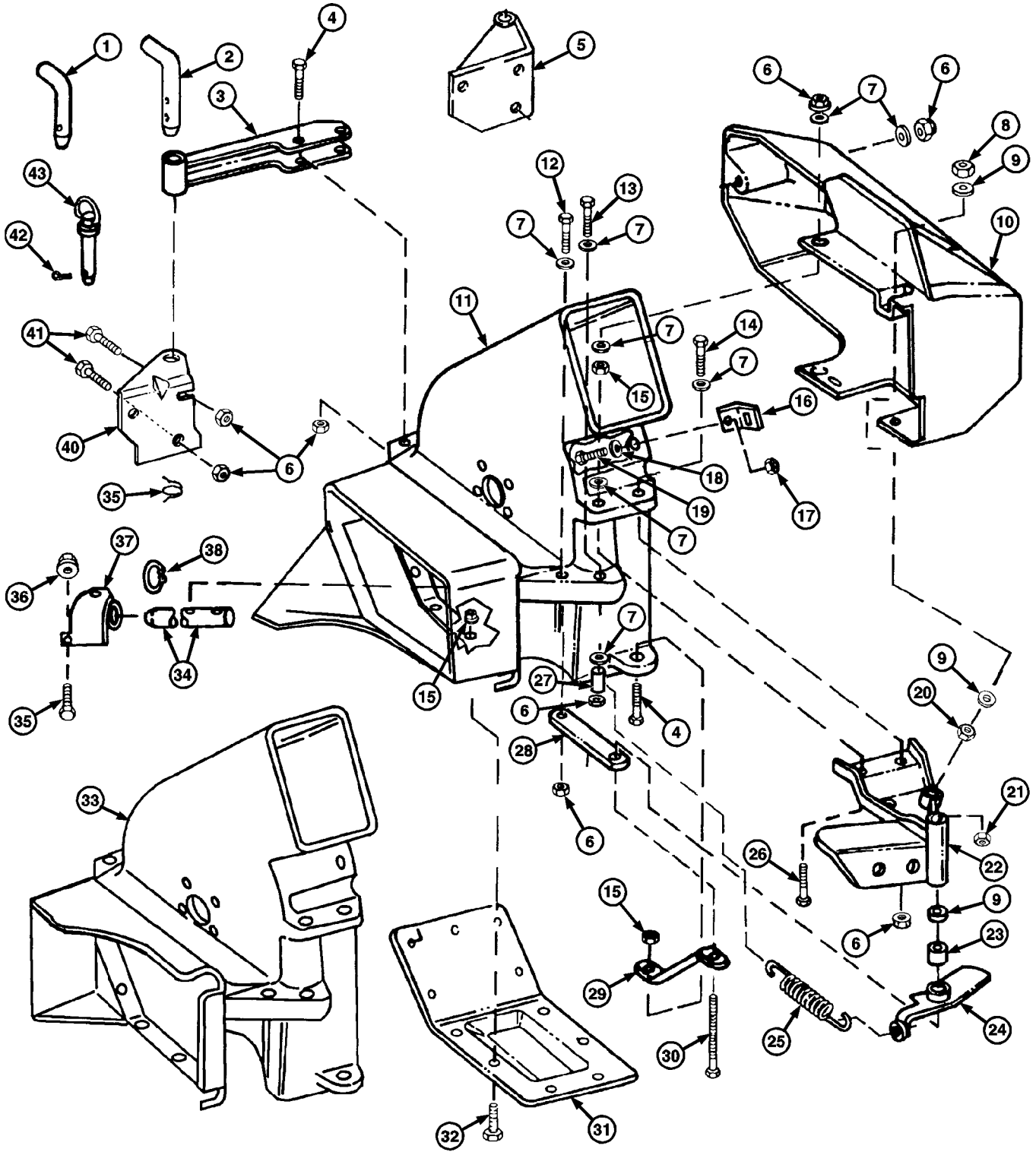

80
20
6

MB3029 -JUN-25AUG95

MX.8020CL.H -19-23OCT95

Power Flow™ Blower Assembly/Blower Housing

1—Pin (S.N. —597777)	12—Cap Screw (2 used)	23—Bushing	34—Pin
2—Pin (S.N. 597778—)	13—Cap Screw	24—Bushing	35—Cap Screw
3—Bracket	14—Cap Screw	25—Spring	36—Lock Nut (2 used)
4—Cap Screw (3 used)	15—Lock Nut (12 used)	26—Cap Screw (2 used)	37—Bracket
5—Bracket (S.N. —597777)	16—Striker	27—Bushing	38—Snap Ring
6—Lock Nut (6 used)	17—Lock Nut	28—Strap	39—Spring Locking Pin
7—Washer (7 used)	18—Washer	29—Pin	40—Bracket
8—Lock Nut	19—Cap Screw	30—Cap Screw	41—Cap Screw (3 used)
9—Washer (3 used)	20—Nut	31—Plate	42—Spring Locking Pin
10—Shield	21—Lock Nut	32—Screw (11 used)	43—Pin
11—Housing (S.N. 597778—)	22—Bracket	33—Housing (S.N. —597777)	

1. Inspect parts for wear or damage. Replace damaged parts as necessary.

MX,8020CL,H1 -19-23OCT95

80
20
7

REPAIR BLOWER HOUSING (48-INCH MOWER DECK)

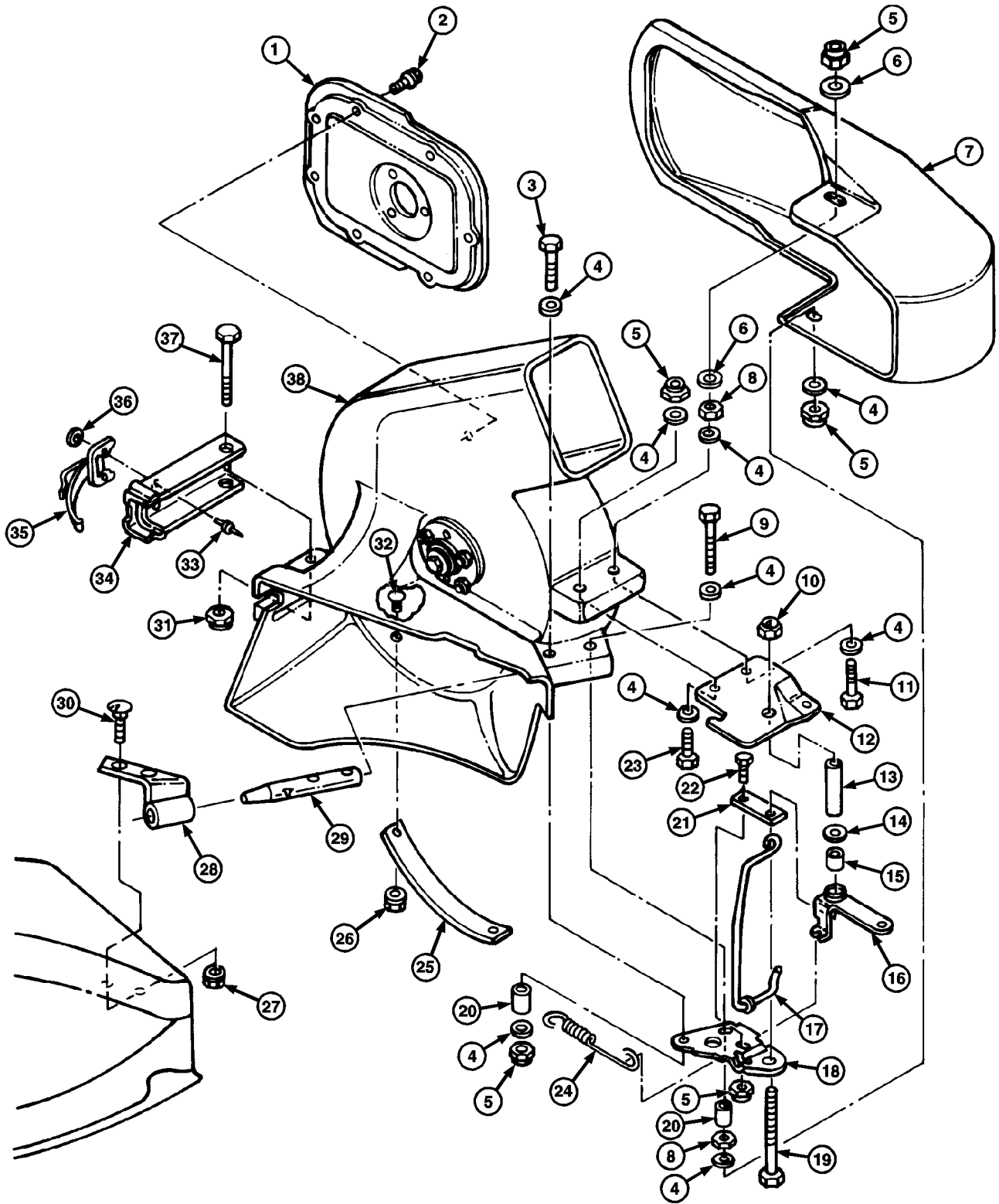

80
20
8

MB3030 -JUN-25AUG95

MX,8020CL,I -19-23OCT95

Power Flow™ Blower Assembly/Blower Housing

1—Panel	11—Cap Screw	21—Strap	30—Bolt (2 used)
2—Screw (7 used)	12—Bracket	22—Cap Screw	31—Lock Nut
3—Cap Screw	13—Bushing	23—Cap Screw	32—Bolt (2 used)
4—Washer (9 used)	14—Washer	24—Spring	33—Rivet (2 used)
5—Lock Nut (5 used)	15—Pivot Bushing	25—Wear Strap	34—Bracket
6—Washer (2 used)	16—Idle Arm	26—Nut (2 used)	35—Latch
7—Shield	17—Lever	27—Lock Nut (2 used)	36—Washer (2 used)
8—Nut (2 used)	18—Bracket	28—Bracket	37—Cap Screw
9—Cap Screw	19—Cap Screw	29—Pin	38—Housing
10—Lock Nut	20—Bushing		

1. Inspect parts for wear or damage. Replace damaged parts as necessary.

MX,8020CL,11 -19-23OCT95

80
20
9

REPAIR HOPPER TOP AND MOUNTING BRACKET

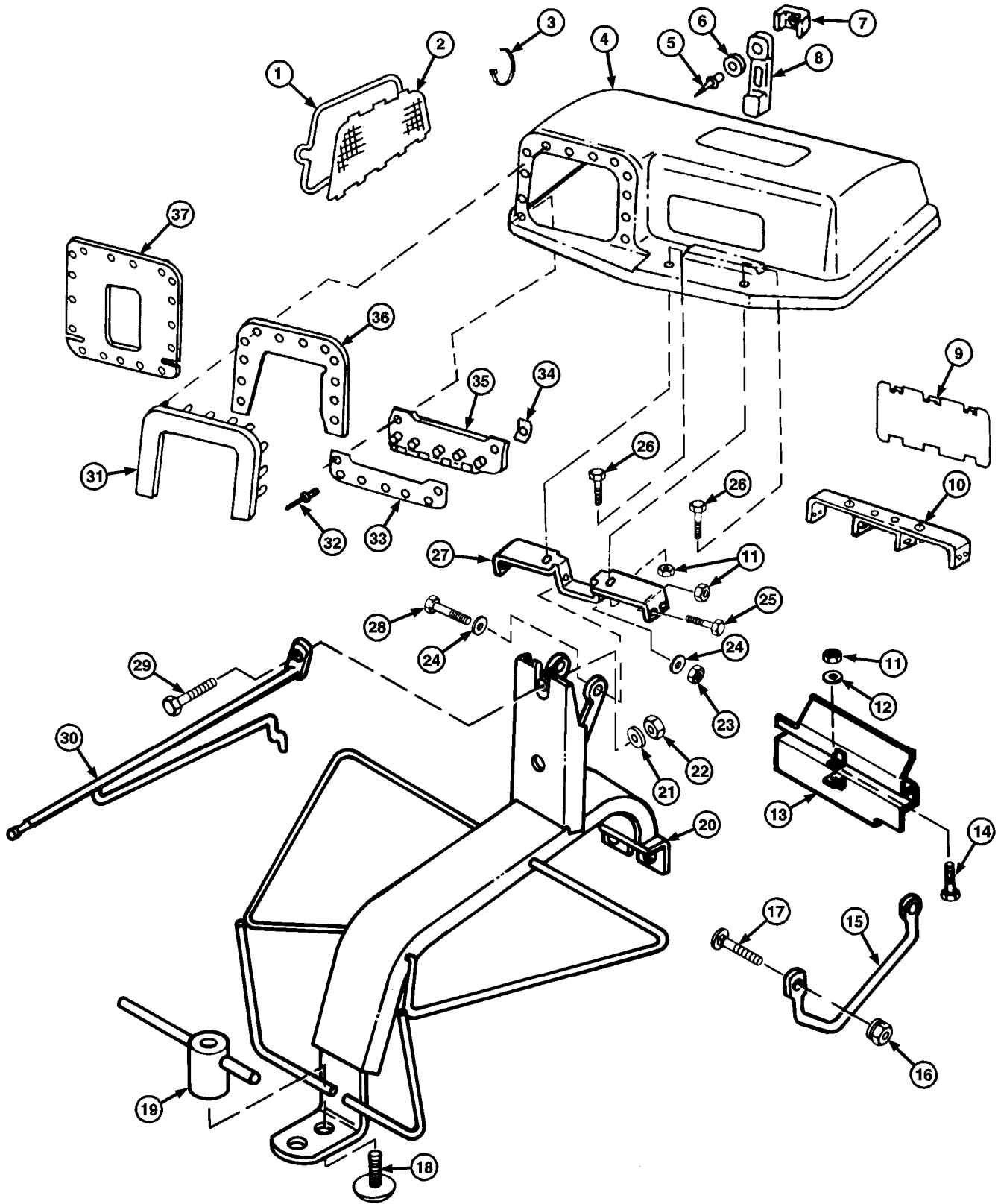

80
20
10

M58391 -UN-25AUG95

Power Flow™ Blower Assembly/Hopper Top and Mounting Bracket

1—Frame	11—Lock Nut (8 used)	20—Bracket	29—Cap Screw
2—Screen	12—Bushing (2 used)	21—Washer	30—Retainer
3—Tie Band (3 used)	13—Shield	22—Lock Nut	31—Outer Retainer
4—Cover	14—Cap Screw (2 used)	23—Lock Nut (2 used)	32—Rivet (3 used)
5—Rivet	15—Bracket	24—Washer (4 used)	33—Seal
6—Washer	16—Lock Nut	25—Screw (4 used)	34—Nut (12 used)
7—Clip	17—Bolt	26—Screw (2 used)	34—Retainer
8—Latch	18—Bolt	27—Bracket	35—Seal
9—Window (2 used)	19—Retainer	28—Cap Screw (2 used)	36—Seal
10—Bracket			

1. Inspect parts for wear or damage. Replace damaged parts as necessary.

MX,8020CL,J1 -19-23OCT95

80
20
11

80
20
12

REMOVE AND INSTALL REAR SHROUD

1. Remove cap screws (A).
2. Remove rear shroud. Replace if damaged.
3. Install rear shroud.
4. Install cap screws (A).



MX,7020CL,A1 -19-04MAY92

M53060
-UN-13APR89

REMOVE AND INSTALL SEAT PLATFORM

1. Disconnect seat switch harness (A). Remove from seat platform.
2. Remove pins (B).
3. Disengage latch rod (C).
4. Remove seat platform.
5. Engage latch rod. Install cover using pins.
6. Connect seat switch harness and secure to seat platform with wire ties.



MX,7020CL,A2 -19-23OCT95

M53076
-UN-13APR89

RIGHT FENDER—SERVICE REMOVAL

1. Disconnect throttle cable at carburetor.
2. Remove cap screws. (See Fender Replacement in this group.)
3. Disconnect wire harness at (A), (B) and (C).
4. Disconnect lever (D).
5. Position fender away from service area.
6. Install fender.
7. Connect lever (D).
8. Connect wire harness at (A), (B) and (C).
9. Install cap screws. (See Fender Replacement in this group.)

A—Fuel Solenoid Connector
B—Oil Switch Terminal
C—PTO Connector
D—Park Brake Lever



MX,7020CL,A4 -19-23OCT95

RIGHT FENDER—FENDER REPLACEMENT

1. Remove cap screws (A).
2. Remove knobs (B).
3. Remove console (C).
4. Remove lever (D).
5. Disconnect throttle cable at carburetor.
6. Disconnect bracket assembly.
7. Replace fender.
8. Close rear shroud and align fender with shroud.
9. Connect bracket assembly and throttle cable.
10. Install lever (D), console (C) and knobs (B).
11. Install cap screws (A).
12. Adjust throttle cable. (See Throttle Cable Adjustment in Section 220, Group 15.)

A—Cap screws
B—Brake and Throttle Knobs
C—Console
D—Park Brake Lever

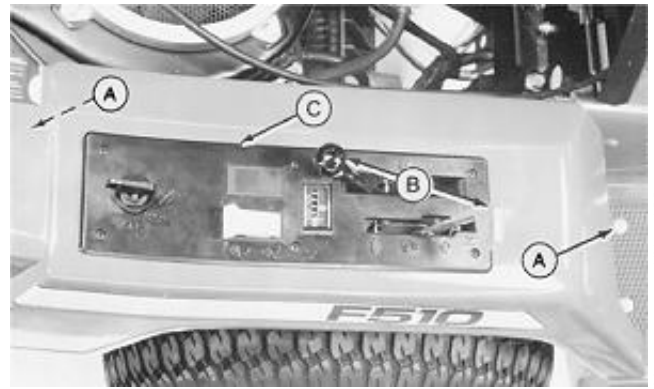

Early Model Shown



MX,7020CL,A3 -19-23OCT95

LEFT FENDER REPLACEMENT

1. Remove fuel tank. (See Remove and Install Fuel Tank in Section 30, Group 05.)
2. Remove cap screws (A).
3. Remove fender.
4. Install fender.
5. Install caps screws (A).
6. Install fuel tank.



MX,7020CL,A5 -19-23OCT95

REPAIR WEIGHT TRANSFER SYSTEM

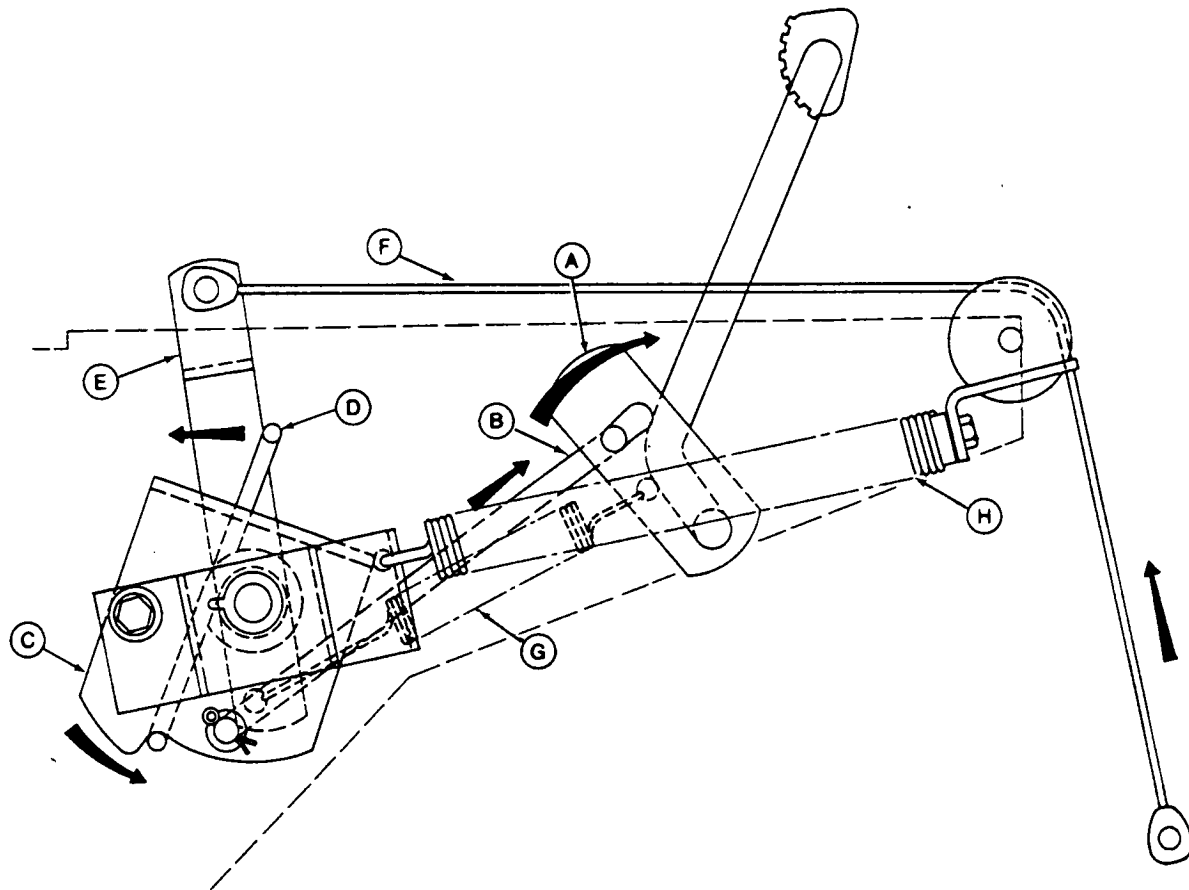

A—Cable
B—Pedal Arm

C—Assist Spring
D—Return Spring

E—Link Rod
F—Torsion Spring

G—Cable Arm
H—Torsion Spring Plate

1. Check springs (C), (D), and (F) for binding, cracks, or damage.
2. Check linkage (B), (E), and (G) for bent, broken, or damaged components.
3. Check pedal and pulley pivot points for wear or damage. Inspect bushings for wear.

4. Check cable (A) for fraying or worn attachment points.
5. Repair or replace any worn or damaged components.

M53041 -UN-05APR89

MX,28015CL,A1 -19-23OCT95

80
30
2

Section 210

SPECIFICATIONS/OPERATIONAL CHECKOUT PROCEDURE

Contents

Page

Group 05—Operational Checkout Procedure

Before You Start	210-05-1
Engine/Transaxle Oil Check	210-05-1
Fuel Leak Check	210-05-2
Air Cleaner And Intake Screen Check . . .	210-05-2
Prestart Checks	210-05-3
Starting Circuit Checks	210-05-4
Indicator Lamp Running Check	210-05-4
Seat Switch Check With Engine Running .	210-05-4
Brake Switch Safety Circuit Check	210-05-4
PTO Switch Safety Circuit Check	210-05-5
PTO Check	210-05-5
Throttle And Choke Lever Check	210-05-6
Engine Performance Check	210-05-6
Engine Stop Check	210-05-6
Transaxle Forward/Reverse Performance Check	210-05-7
Transaxle Neutral/Return Check	210-05-7
Transaxle Neutral Return Check	210-05-7
Master Brake Pedal Lock Check	210-05-8
Steering Check	210-05-8
Weight Transfer Check	210-05-8
Checkout Procedure Complete	210-05-9

Group 10—Test and Adjustment Specifications

Test and Adjustment Specifications	210-10-1
----------------------------------------------	----------

BEFORE YOU START

Always begin with this group to identify a failure in a system. The step-by-step procedures will provide you with a quick check of the system. No tools are required to perform these checks. If a failure is indicated, you will be referred to a more detailed check, adjustment, or test.

Always start with the first step and follow the sequence from left to right. Read each step completely before performing the check. This procedure is designed as a quick check of the system. While performing the check, concentrate only on the check you are performing and disregard signals from unrelated components.

MX,21005CL,A1 -19-04MAY92

1 ENGINE/TRANSAXLE OIL CHECK

Check engine oil level, condition, and viscosity.



M43655 -UN-31AUG88

Check oil level with engine warm. Remove, wipe clean and insert dipstick on threads. Turn dipstick counterclockwise until it "clicks" or drops down to bottom of threads. Remove and check oil level, oil should be between "ADD" and "FULL" marks. Oil level will vary approximately 2 mm (0.08 in.) between a warm and cold engine.

Inspect oil for presence of fuel or metal particles. Check oil for milky appearance or burnt odor.

Inspect for external oil leakage from oil pressure sensor, oil filter, oil filter manifold, crankcase cover gasket, dipstick tube seals, crankshaft seals, valve cover gasket, head gasket, governor shaft seal, reciprocating balancer seal and drain plug.

OK: GO TO 2

NOT OK: Repair or replace. (See Section 20.)

MX,21005CL,A2 -19-23OCT95

210
05
1

Operational Checkout Procedure/Air Cleaner And Intake Screen Check

2 FUEL LEAK CHECK

⚠ CAUTION:
Gasoline is explosive.
DO NOT expose to
spark or flame.
Serious personal
injury may result.
Wipe-up any spilled
fuel IMMEDIATELY.
Allow engine to cool
before working on
exhaust or fuel
system.



M53165 -UN-21AUG89

Inspect for external fuel leakage from fuel tank, fuel pump, fuel filter, carburetor, fuel lines, fuel shutoff valve and fittings.

OK: GO TO **3**

NOT OK: Repair or replace. (See Section 30.)

MX,21005CL,A3 -19-23OCT95

3 AIR CLEANER AND AIR INTAKE SCREEN CHECK

Remove air cleaner cover.



M43657 -UN-31AUG88

Inspect precleaner, filter element, and air intake screen for debris or plugged condition. Inspect cooling fins and area around flywheel fan for buildup of dust and debris.

OK: GO TO **4**

NOT OK: Clean or replace. (See Section 30, Group 15.)



M43658 -UN-31AUG88

MX,21005CL,A4 -19-23OCT95

4 PRESTART CHECKS

⚠ CAUTION:
Gasoline is explosive. DO NOT expose to spark or flame. Serious personal injury may result. Wipe-up any spilled fuel IMMEDIATELY. Allow engine to cool before working on exhaust or fuel system.



M53164 -UN-21AUG89

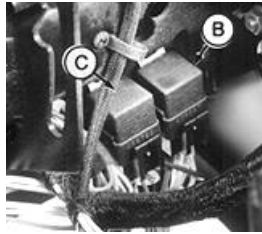

M83009 -UN-23JUN95



M83010 -UN-23JUN95

A. Key Switch in RUN position. Engine OFF. Seat switch OFF (Operator off seat). Brake switch OFF.

FEEL/LISTEN: Fuel shutoff solenoid (A) should retract with a "click".

PTO relay (B) should engage with a "click".

LOOK: Battery discharge and oil pressure lamps should be ON.

Low fuel lamp will only come on if fuel level is low. Siphon fuel from tank (capacity 10.4 L [2.75 U.S. gal]), until low fuel light is ON. Add fuel until light is OFF.

Hourmeter should advance 1/10 hr every 6 minutes.

B. Key switch in run position. Engine OFF. Seat switch ON (Operator on seat). Brake switch OFF.

FEEL/LISTEN: All items mentioned above should occur plus—PTO relay (B) and ignition relay (C) should engage with a "click".

OK: GO TO 5

NOT OK: Fuel shut-off solenoid does not retract. See Fuel Shut-Off Solenoid Circuit Test in Section 240, Group 15.





PTO and/or ignition relay(s) do not "click". See PTO Circuit Test or Ignition Circuit Test in Section 240, Group 15.

Indicator lights not ON. See Hourmeter, Low Fuel And Oil Pressure Light Test Points in Section 240, Group 15.

Low fuel light not ON after draining fuel. See Hourmeter, Low Fuel And Oil Pressure Light Test Points in Section 240, Group 15.

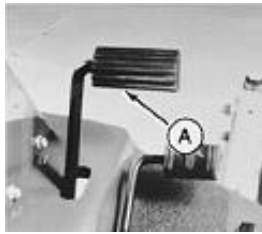
Hourmeter does not advance. See Hourmeter, Low Fuel And Oil Pressure Light Test Points in Section 240, Group 15.

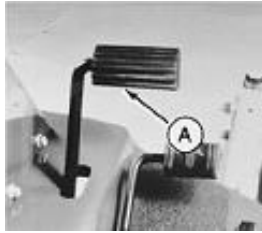
Operational Checkout Procedure/Brake Switch Safety Circuit Check

<p>5 STARTING CIRCUIT CHECKS</p>	<p>Seat switch ON (Operator on seat). Put PTO switch in OFF position.</p>	 <p>M53161 -UN-21AUG89</p>	<p>Fully depress or lock master brake pedal (A) (brake switch ON). Turn key switch to start position. <i>LISTEN: Starter must crank engine. Engine must start (use choke as needed).</i></p>	<p>OK: GO TO 6 NOT OK: Engine will not crank. See Cranking Circuit Test Points in Section 240, Group 15. NOT OK: Engine will crank but will not start. See Engine Cranks But Will Not Start in Section 220, Group 15.</p>
<p>6 INDICATOR LAMP RUNNING CHECK</p>	<p>Lock master brake. Put PTO switch in OFF position. Start engine and run at full throttle.</p>	 <p>M53164 -UN-21AUG89</p>	<p><i>LOOK: Battery discharge lamp must be OFF.</i> Oil pressure lamp must be OFF. Engine oil must not leak from oil filter or manifold gaskets.</p>	<p>OK: GO TO 8 NOT OK: Oil pressure lamp ON. Test engine oil pressure. See Oil Pressure Test in Section 220, Group 15). Oil pressure OK: See Hourmeter, Low Fuel And Oil Pressure Light Test Points in Section 240, Group 15. Discharge light ON: See Charging And Discharge Light Circuit Test Points in Section 240, Group 15.</p>
<p>7 SEAT SWITCH CHECK WITH ENGINE RUNNING</p>	<p>Seat switch ON (Operator on seat). Lock master brake.</p>	 <p>M53161 -UN-21AUG89</p>	<p>Release master brake pedal (A). Raise up off seat. <i>LISTEN: Engine must stop.</i></p>	<p>OK: GO TO 8 NOT OK: See Ignition Power Circuit Test Points in Section 240, Group 15.</p>
<p>8 BRAKE SWITCH SAFETY CIRCUIT CHECK ⚠ CAUTION: If brake switch circuit is defective, engine could start.</p>	<p>Engine OFF. Put PTO switch in OFF position. Master brake pedal released.</p>	 <p>M53167 -UN-21AUG89</p>	<p>Turn key to start position. <i>LISTEN: Starter must NOT crank engine.</i></p>	<p>OK: GO TO 10 NOT OK: See Brake Switch Test And Adjustment in Section 240, Group 15.</p>

210
05
4

Operational Checkout Procedure/PTO Check

9 PTO SWITCH SAFETY CIRCUIT CHECK

⚠ CAUTION: If PTO Switch Circuit is defective, engine could start and mower could run.

Engine OFF.
Put PTO switch in ON position.
Master brake pedal depressed.



M53167 -UN-21AUG89

Turn key to start position.
LISTEN: Starter must NOT crank engine.

OK: GO TO 10.
NOT OK: See PTO Switch Test in Section 240, Group 15.

MX,21005CL,A12 -19-23OCT95

10 PTO CHECK

Engine OFF.
Seat switch ON (Operator on seat).
Release master brake.
Turn key to run position.



M53166 -UN-21AUG89



M81627 -19-15MAY95

Put PTO switch in ON position.
LISTEN: PTO clutch must click ON (magnet releasing clutch brake).



M45925 -UN-22APR92



OK: GO TO 11.
NOT OK: See PTO Circuit Test Points in Section 240, Group 15.

MX,21005CL,A13 -19-23OCT95

210
05
5

Operational Checkout Procedure/Engine Stop Check

<p>11 THROTTLE AND CHOKE LEVER CHECK</p>	<p>Seat switch ON (Operator on seat). Put PTO switch in OFF position. Start and run engine.</p>	 <p>M53163 -UN-21AUG89</p> <p>Accelerate engine from slow to fast idle. <i>LISTEN: Engine must accelerate smoothly without hesitation.</i> Push throttle lever past detent to choke position, then return to fast idle. <i>LISTEN: Engine must falter, then resume speed.</i></p>	<p>OK: GO TO 12. NOT OK: See Throttle Cable Adjustment and Choke Adjustment in Section 220, Group 15.</p> <p>MX,21005CL,A14 -19-23OCT95</p>
-------------------------------------------------	---------------------------------------------------------------------------------------------------------	--------------------------------------------------------------------------------------------------------------------------------------------------------------------------------------------------------------------------------------------------------------------------------------------------------------------------------------------------------------------------------	---------------------------------------------------------------------------------------------------------------------------------------------------------------



<p>12 ENGINE PERFORMANCE CHECK</p>	<p>Seat switch ON (Operator on seat). Put PTO switch in OFF position. Start and run engine.</p>	 <p>M53166 -UN-21AUG89</p>  <p>M81627 -19-15MAY95</p>  <p>M45925 -UN-22APR92</p>	<p>Move throttle lever from slow idle to fast idle position. <i>LISTEN: Engine must accelerate smoothly, without hesitation.</i> Engage PTO switch. Mow tall grass, if possible, to load engine. <i>LISTEN: Governor must increase and decrease engine rpm smoothly to match load conditions.</i></p>
-------------------------------------------	---------------------------------------------------------------------------------------------------------	----------------------------------------------------------------------------------------------------------------------------------------------------------------------------------------------------------------------------------------------------------------------------------------------------------------------------------------	-------------------------------------------------------------------------------------------------------------------------------------------------------------------------------------------------------------------------------------------------------------------------------------------------------------------

<p><i>LOOK: Exhaust gas must be clear.</i> <i>LISTEN: Engine must not make any abnormal sounds or backfire. Engine must not hesitate or stumble.</i></p>	<p>OK: GO TO 13 NOT OK: See Engine Backfires Through Carburetor or Engine Misses in Section 220, Group 15.</p> <p>MX,21005CL,A15 -19-23OCT95</p>
--------------------------------------------------------------------------------------------------------------------------------------------------------------	--------------------------------------------------------------------------------------------------------------------------------------------------------------------

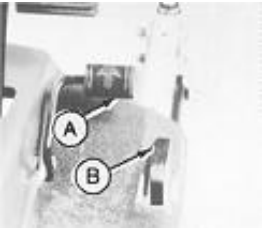

<p>13 ENGINE STOP CHECK</p>	<p>With engine warm, idle engine for 30 seconds, then shut off key.</p>	<p><i>LISTEN: Engine must stop.</i> <i>NOTE: Occasional backfire may occur.</i></p>	<p>OK: GO TO 14 NOT OK: Engine will not shut off, see Magneto And Ground Circuit Test Points in Section 240, Group 15. Engine backfires at every shutdown, see Engine Backfires Through Muffler When Engine Is Shut Off in Section 220, Group 15.</p> <p>MX,21005CL,A15A-19-23OCT95</p>
------------------------------------	-------------------------------------------------------------------------	-----------------------------------------------------------------------------------------	-----------------------------------------------------------------------------------------------------------------------------------------------------------------------------------------------------------------------------------------------------------------------------------------------------------

210
05
6

Operational Checkout Procedure/Transaxle Neutral Return Check

<p>14 TRANSAXLE FORWARD/REVERSE PERFORMANCE CHECK</p>	<p>Seat switch ON (Operator on seat).</p> <p>Put PTO switch in OFF position.</p> <p>Release master brake.</p> <p>Start and run engine at full throttle.</p>		
 <p>Fully depress forward (A), then reverse (B) pedals.</p> <p><i>FEEL: Machine must accelerate and decelerate smoothly from forward to reverse.</i></p> <p>M53160 -UN-21AUG89</p>		<p>OK: GO TO 15.</p> <p>NOT OK: See Erratic Drive In Both Directions in Section 250, Group 15.</p> <p>MX,21005CL,A16 -19-23OCT95</p>	
<p>15 TRANSAXLE NEUTRAL CHECK</p>	<p>Seat switch ON (Operator on seat).</p> <p>Release master brake.</p> <p>Put PTO switch in OFF position.</p> <p>Start engine and run at half throttle.</p>	 <p>Depress forward (A) or reverse (B) pedals, then release.</p> <p><i>LOOK: Front mower must not creep in neutral.</i></p> <p>M53160 -UN-21AUG89</p>	<p>OK: GO TO 16.</p> <p>NOT OK: See Neutral Adjustment in Section 250, Group 15.</p> <p>MX,21005CL,A17 -19-23OCT95</p>
<p>16 TRANSAXLE NEUTRAL CHECK</p>	<p>Seat switch ON (Operator on seat).</p> <p>Release master brake.</p> <p>Put PTO switch in OFF position.</p> <p>Start engine and run at half throttle.</p>	 <p>Drive front mower forward. Depress brake pedal (A).</p> <p>Drive front mower in reverse. Depress brake pedal.</p> <p><i>LOOK: Pedals should return to neutral position when brake is depressed.</i></p> <p>Front mower must not creep forward.</p> <p>M53161 -UN-21AUG89</p>	<p>OK: GO TO 17.</p> <p>NOT OK: See Neutral Return Linkage Adjustment in Section 250, Group 15.</p> <p>MX,21005CL,A18 -19-23OCT95</p>

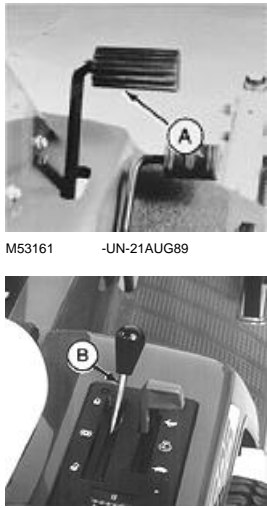
Operational Checkout Procedure/Weight Transfer Check

<p>17 MASTER BRAKE PEDAL LOCK CHECK</p>	<p>Turn engine OFF.</p>	 <p>M53161 -UN-21AUG89</p> <p>M83043 -UN-25AUG95</p> <p>Depress master brake pedal (A) fully.</p> <p>Move park brake lever (B) to locked position.</p> <p><i>LOOK: Pedal must stay engaged.</i></p> <p>Depress pedal fully. Move lever to unlocked position and release pedal.</p> <p><i>LOOK: Pedal must return to normal position.</i></p>	<p>OK: GO TO 18.</p> <p>NOT OK: See Brake Pedal Travel Adjustment in Section 260, Group 15.</p> <p>MX,21005CL,A19 -19-23OCT95</p>
<p>18 STEERING CHECK</p>	<p>Engine OFF.</p> <p>Seat switch ON (Operator on seat).</p> <p>Lock master brake.</p>	 <p>M53217 -UN-21AUG89</p> <p>Turn steering wheel full left and full right.</p> <p><i>FEEL: Wheel must move smoothly in both directions, from stop to stop.</i></p>	<p>OK: GO TO 19.</p> <p>NOT OK: See Steering System Test Points in Section 260, Group 15.</p> <p>MX,21005CL,A20 -19-23OCT95</p>
<p>19 WEIGHT TRANSFER CHECK</p>	<p>Engine OFF.</p> <p>Seat switch ON (Operator on seat).</p> <p>Lock master brake.</p>	 <p>M53218 -UN-21AUG89</p> <p>Depress weight transfer pedal (A).</p> <p><i>FEEL: Pedal should move smoothly with no binding.</i></p> <p><i>LOOK: Cable should lift deck slightly.</i></p> <p>Release weight transfer pedal.</p> <p><i>LOOK: Pedal should return to release position. Deck should return to original position.</i></p>	<p>OK: GO TO 20.</p> <p>NOT OK: See Weight Transfer System Checks in Section 280, Group 15.</p> <p>MX,21005CL,A21 -19-23OCT95</p>

Operational Checkout Procedure/Checkout Procedure Complete

<p>20 CHECKOUT PROCEDURE COMPLETE</p>	<p>If you completed the checkout procedure and did not isolate a malfunction, the problem may be intermittent.</p> <p>Try to duplicate the conditions of the malfunction identified by the operator.</p>	<p>Repeat system checkout in this group.</p>	<p>IF MALFUNCTION IS NOT IDENTIFIED AFTER REPEATING SYSTEM CHECKOUT PROCEDURE; FACTORY ASSISTANCE IS AVAILABLE THROUGH THE DEALER TECHNICAL ASSISTANCE CENTER (DTAC).</p> <p>MX,21005CL,A22 -19-23OCT95</p>
----------------------------------------------	----------------------------------------------------------------------------------------------------------------------------------------------------------------------------------------------------------	----------------------------------------------	-------------------------------------------------------------------------------------------------------------------------------------------------------------------------------------------------------------

210
05
9

210
05
10

TEST AND ADJUSTMENT SPECIFICATIONS

ITEM	SPECIFICATIONS
ENGINE	
A.C.R. (Minimum)	Exhaust valve open 0.25 mm (0.01 in.)
Breather Air Gap	1—2 mm (0.04—0.08 in.)
Compression (Minimum)	483 kPa (71 psi)
Crankcase Vacuum (Minimum)	17 cm (6.5 in.) water
Oil Pressure at WOT (Wide Open Throttle)	240 kPa (35 psi)
Valve Clearance (cold)	0.15 mm (0.006 in.)
Oil Sender	Closed below 28 kPa (2.8 bar) (4 psi.)
Oil Consumption F510 (PA420A)	More than full to add in 8 hrs. Repair engine.
F525 (PA540A)	More than full to add in 11 hrs. Repair engine.
FUEL SYSTEM	
Fuel Pump Flow (Minimum):	
F510 (PA420A)	80 mL (2.7 oz)/15 seconds
F525 (PA540A)	90 mL (3 oz)/15 seconds
Fuel Pump Pressure (Minimum)	6.12 kPa (0.9 psi)
Slow Idle Speed:	
F510 (-100203) and F525 (-100392)	1400—1500 rpm
F510 (100204-) and F525 (100393-):	
Throttle control lever stop screw setting	1450—1550 rpm
Carburetor slow idle stop screw	1350—1450 rpm
Fast Idle Speed	3250—3450 rpm
Float	Non-adjustable
ELECTRICAL	
Armature Air Gap	0.30 mm (0.012 in.)
Battery Voltage	12.2—14.7 V at 3350 rpm
Ignition Coil Resistance:	
F510 (-100203) and F525 (-100392)	
Primary Lead/Core	0.48—0.72 ohms
Spark Plug Lead/Core	10.9—16.3 k ohms
F510 (100204-) and F525 (100393-)	
Primary Lead/Core	0.4—0.8 ohms
Spark Plug Lead/Core	8.7—13.1 k ohms
Low Fuel Sender	Float bottomed: continuity
PTO Clutch Air Gap	0.38-0.64 mm (0.015-0.025 in.)
Spark Plug Gap	0.76 mm (0.030 in.)
Starter Amp Draw (Maximum):	
F510 (PA420A)	60 amps at 500 rpm
F525 (PA540A)	85 amps at 500 rpm
Starter No-Load Draw (Maximum):	
F510 (PA420A)	50 amps at 6000 rpm
F525 (PA540A)	50 amps at 5000 rpm

Continued on next page

MX,21005CL,A23 -19-23OCT95

ITEM	SPECIFICATIONS
ELECTRICAL-CONTINUED	
Regulated Amperage (Minimum):	
F510 (PA420A)	11 amps
F525 (PA540A)	13 amps
Unregulated Voltage (Minimum):	
F510 (PA420A)	30 VAC
F525 (PA540A)	27 VAC
Engine Cranking Speed (Minimum)	250 rpm
Automatic Compression Release Off	600-900 rpm
POWER TRAIN	
Neutral Adjustment	Cam roller in neutral notch
Neutral Return Linkage Adjustment	Brake depressed: roller in slot
Pedal Travel Adjustment	Full swash plate travel before pedal bottoms
STEERING	
Linkage Adjustment	Steering wheel and rear wheel centered.
BRAKE	
Pedal Free Play	15 mm (0.59 in.)
ADJUSTMENTS	

21005CL,A23,A -19-23OCT95

Section 220

ENGINE OPERATION, TESTS, AND

Contents

	Page	Page
Group 05—Engine Component Location		
Component Location Information	220-05-1	
Exterior Engine Components	220-05-2	
Internal Engine Components	220-05-4	
Group 10—Theory of Operation		
Theory of Operation Information	220-10-1	
Engine Description	220-10-1	
Features of Engine		
Components—Crankshaft	220-10-2	
Camshaft	220-10-2	
Lubrication System Operation	220-10-4	
Engine Lubrication Circuit	220-10-6	
Breather System Operation	220-10-8	
Cooling System	220-10-10	
Automatic Compression Release	220-10-12	
Group 15—Diagnosis, Tests, and Adjustments		
Diagnostic Information	220-15-1	
Engine Cranks But Will Not Start	220-15-2	
Engine Flooding	220-15-4	
Lack of Fuel in Carburetor	220-15-6	
Engine Starts Hard Or Stops When Hot	220-15-8	
Engine Surging	220-15-10	
Engine Backfires Through Carburetor	220-15-12	
Engine Backfires Through Muffler When Engine is Shut Off	220-15-14	
Engine Misses	220-15-16	
Engine Loses Power or Runs Rough When Hot	220-15-18	
Engine Has Black Exhaust Smoke	220-15-20	
Engine Has Blue Exhaust Smoke or Oil in Air Filter Housing	220-15-22	
Engine Uses Too Much Oil	220-15-24	
Throttle Cable Adjustment	220-15-26	
Choke Plate Check	220-15-27	
Choke Plate Adjustment	220-15-29	
Governor Adjustment	220-15-29	
Fast Idle Speed Adjustment	220-15-30	
Slow Idle Speed Adjustment F510(—100203) and F525(—100392)	220-15-31	
F510(100204—) and F525(100393—)	220-15-32	
Cylinder Compression Test	220-15-34	
Compression Leak Check	220-15-35	
Valve Clearance Adjustment	220-15-36	
Automatic Compression Release	220-15-37	
Crankcase Vacuum Test	220-15-38	
Oil Pressure Test	220-15-40	
Fuel Pump Test	220-15-41	

COMPONENT LOCATION INFORMATION

This group contains component location drawings for the following engine system components:

- Exterior Engine Components
- Internal Engine Components

Use the drawings when diagnosing an engine problem and to help locate the components to be tested.

MX,22005CL,1 -19-23OCT95

EXTERIOR ENGINE COMPONENTS

A—Starter Motor
B—Crankcase Cover
C—Solenoid
D—Ignition Module
E—Dipstick
F—Spark Plug
G—Blower Housing

H—Guard
I—Screen
J—Carburetor Inlet Hose
K—Fuel Pump
L—Vacuum Hose
M—Control Plate

N—Throttle and Choke
Linkage
O—Governor Linkage
P—Oil Pressure Switch
Q—Oil Filter
R—Air Cleaner Base

S—Crankcase
T—Fuel Shutoff Solenoid
U—Carburetor
V—Rocker Arm Cover
W—Air Cleaner Housing
X—Air Cleaner Cover

MX,22005CL,2 -19-23OCT95

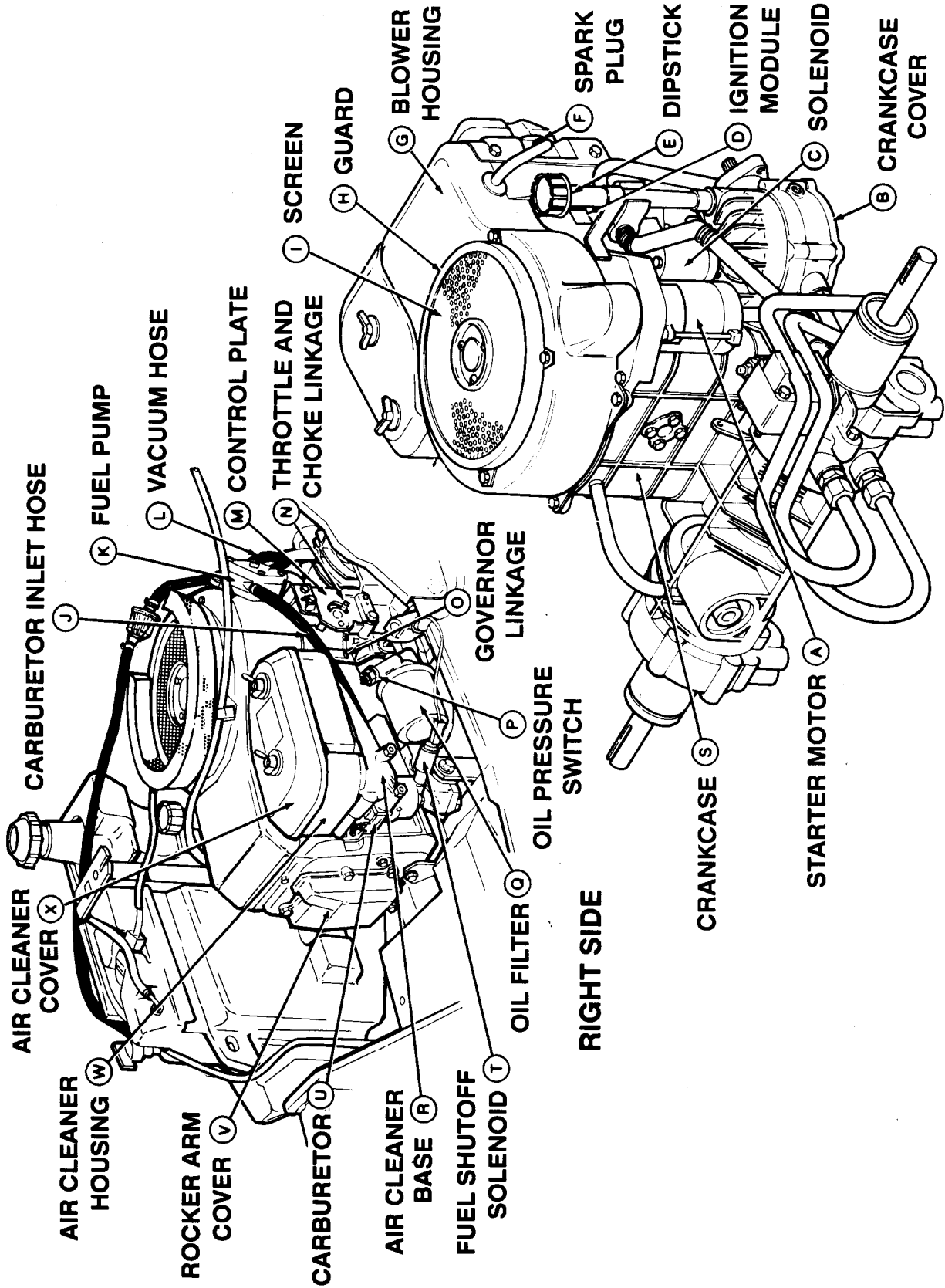

LEFT SIDE

EXTERIOR ENGINE COMPONENTS

RIGHT SIDE

M45945

M45945 -19-11JUN91

220-05

INTERNAL ENGINE COMPONENTS

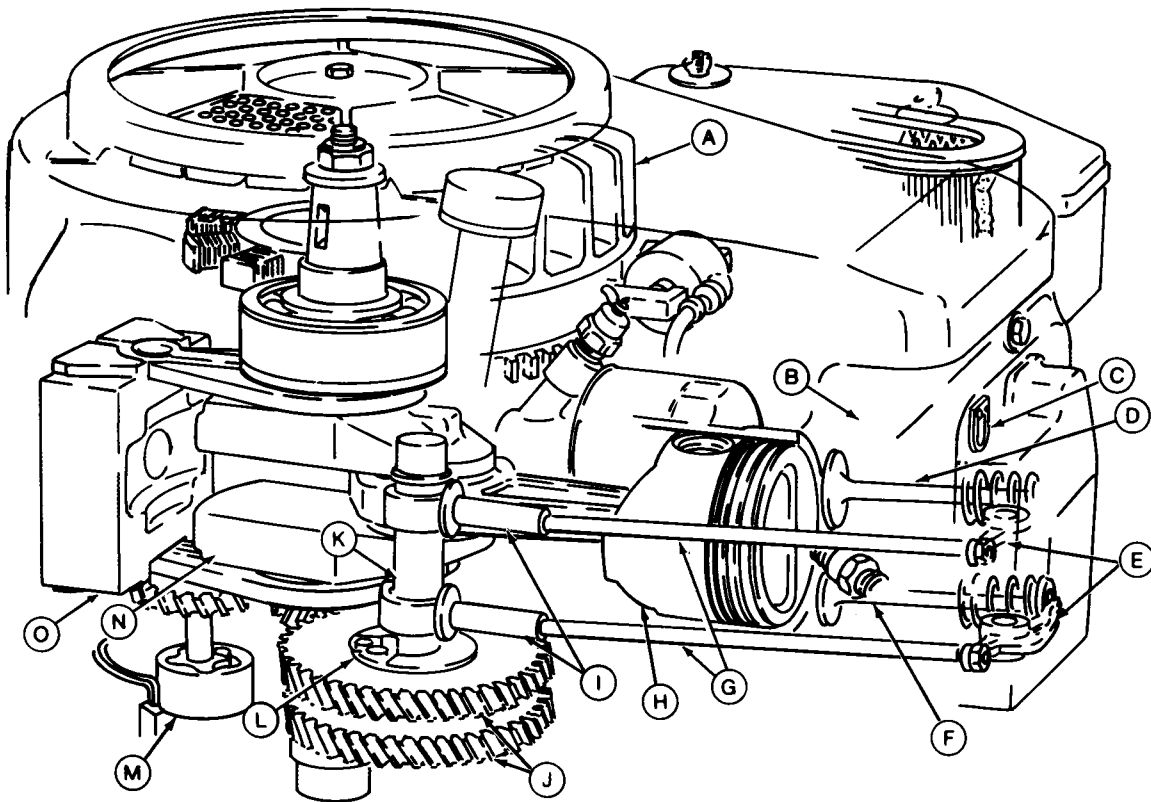

- | | | | |
|-------------------------|--------------------------------------|-------------------------------------------|-----------------------|
| A—Flywheel | F—Exhaust Valve | I—Cam Lifters | M—Oil Pump Assembly |
| B—Cylinder Head | G—Push Rods | J—Twin Gears | N—Crankshaft Assembly |
| C—Breather Valve | H—Piston and Connecting Rod Assembly | K—Camshaft | O—Balancer Assembly |
| D—Intake Valve | | L—Automatic Compression Release Mechanism | |
| E—Rocker Arm Assemblies | | | |

NOTE: Internal governor assembly not shown.

MX,22005CL,4 -19-23OCT95

M53288 -JUN-27JUL95

THEORY OF OPERATION INFORMATION

This group divides the engine into individual components or systems by function. The story contains information on function, component identification, and theory of operation.

The following systems or components are covered:

- Engine Description
- Crankshaft
- Camshaft
- Lubrication
- Cooling
- Compression Release
- Crankcase Breather

MX,22010CL,1 -19-23OCT95

ENGINE DESCRIPTION

The PA420A 14 hp (10.4 kW) engine is used in the F510 Front Mower and is similar to the FC420V engine used in the 175 Lawn Tractor and 240 Lawn and Garden Tractor. The PA540V 17 hp (12.7 kW) engine is used in the F525 Front Mower and is similar to the FC540V engine used in the 180/185 Lawn Tractor, and 260/265 Lawn and Garden Tractor. Both engines are manufactured by Kawasaki.

The engine is part of a unitized power unit consisting of the engine, hydrostatic transaxle, and parking brake. The engine is a four-stroke, overhead valve, single cylinder, air-cooled, modified version of current production FC420V/FC540V engines. An auxiliary gear on the camshaft drives the hydrostatic transaxle.

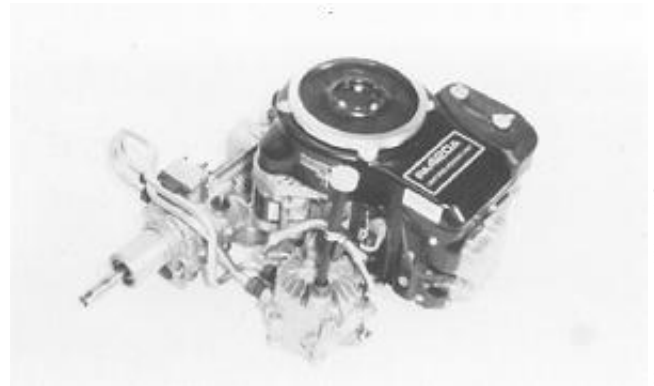

PA420A

M53220 -UN-25AUG89



PA540A

M51890 -UN-21AUG89

MX,22010CL,2 -19-23OCT95

FEATURES OF ENGINE COMPONENTS—CRANKSHAFT

Crankshaft is shorter on the PTO side than that of FC420V/FC540V Kawasaki engines because of unique application in the unitized power unit.

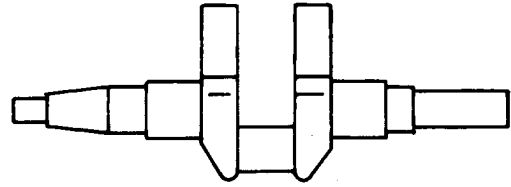

M53289
-UN-21AUG89

MX,22010CL,3 -19-23OCT95

CAMSHAFT

Unique application requires a second helical cut gear to drive the charge pump and variable displacement hydrostatic piston pump.

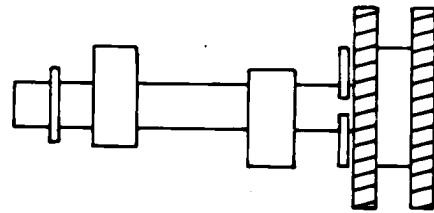

M53290
-UN-21AUG89

MX,22010CL,4 -19-23OCT95

LUBRICATION SYSTEM OPERATION

A—Oil Pressure Relief Valve
 B—Relief Valve Spring
 C—Oil Pump
 D—Screen
 E—Oil Pump Gear

F—Lower Balancer Link
 G—Balancer
 H—Oil Return Passage
 I—Breather Passage
 J—Upper Balancer Link

K—Crankshaft Ball Bearing
 L—Connecting Rod Journal
 M—Connecting Rod Passage
 N—Camshaft Bearing
 O—Crankshaft Main Bearing

P—Oil Pressure Switch
 Q—Oil Filter
 R—Pressure Oil
 S—Pressure-Free Oil
 T—Oil/Air Mixture

Function:

Lubricate internal engine parts.

Major Components:

- Screen
- Oil pump
- Oil pressure relief valve
- Low oil pressure switch
- Oil filter with bypass
- Internal oil passages

Theory of Operation:

A positive displacement gerotor pump is used to pressurize the lubrication system. The oil pump is driven directly off the crankshaft gear. The lubrication system is protected by an oil pressure relief valve, low oil pressure switch, and an oil filter with bypass.

The oil pump (C) draws pressure free oil (S) from the sump through screen (D). Pressure oil (R) from the pump flows through the pump outlet passage past the oil pressure relief valve (A). The oil pressure relief valve limits the oil pressure to approximately 296 kPa (43 psi) and protects the oil pump from damage if an oil passage becomes blocked. If oil pressure exceeds 296 kPa (43 psi), the relief valve opens allowing oil to return to sump. Relief valve is not adjustable.

Pressure oil from the pump outlet passage flows to the oil filter (Q). The filter contains a bypass valve

which opens if the element becomes plugged to insure engine lubrication. An oil pressure switch (P) mounted in the oil filter manifold turns on a warning light if oil pressure is below 28 kPa (4 psi). Filtered pressure oil flows through a passage in the oil sump to the crankshaft main bearing (PTO side) (O) and then to the camshaft bearing (N). Drilled passages in the crankshaft distribute oil from the main bearing to the lower balancer link (F), connecting rod journal (L), upper balancer link (J), and crankshaft ball bearing (flywheel side) (K). A drilled passage (M) in the connecting rod allows oil from the connecting rod journal to lubricate the piston and cylinder.

Pressure-free oil flowing out of the crankshaft ball bearing or upper balancer link also lubricates the balancer (G). A drilled passage in the top of the balancer allows oil to flow to the support shaft and balancer bushing.

The rocker arms, valves, and pushrods are lubricated by an oil/air mixture (T) and carried to the rocker arm cover through the breather passage (I). The breather passage is located directly above the upper pushrod. The oil from the oil/air mixture is separated from the air through the breather maze and flows to the bottom of the cylinder head. This oil drains back to sump through an oil return passage (H) located in the bottom of the cylinder block directly under the lower pushrod.

MX,22010CL,5 -19-23OCT95

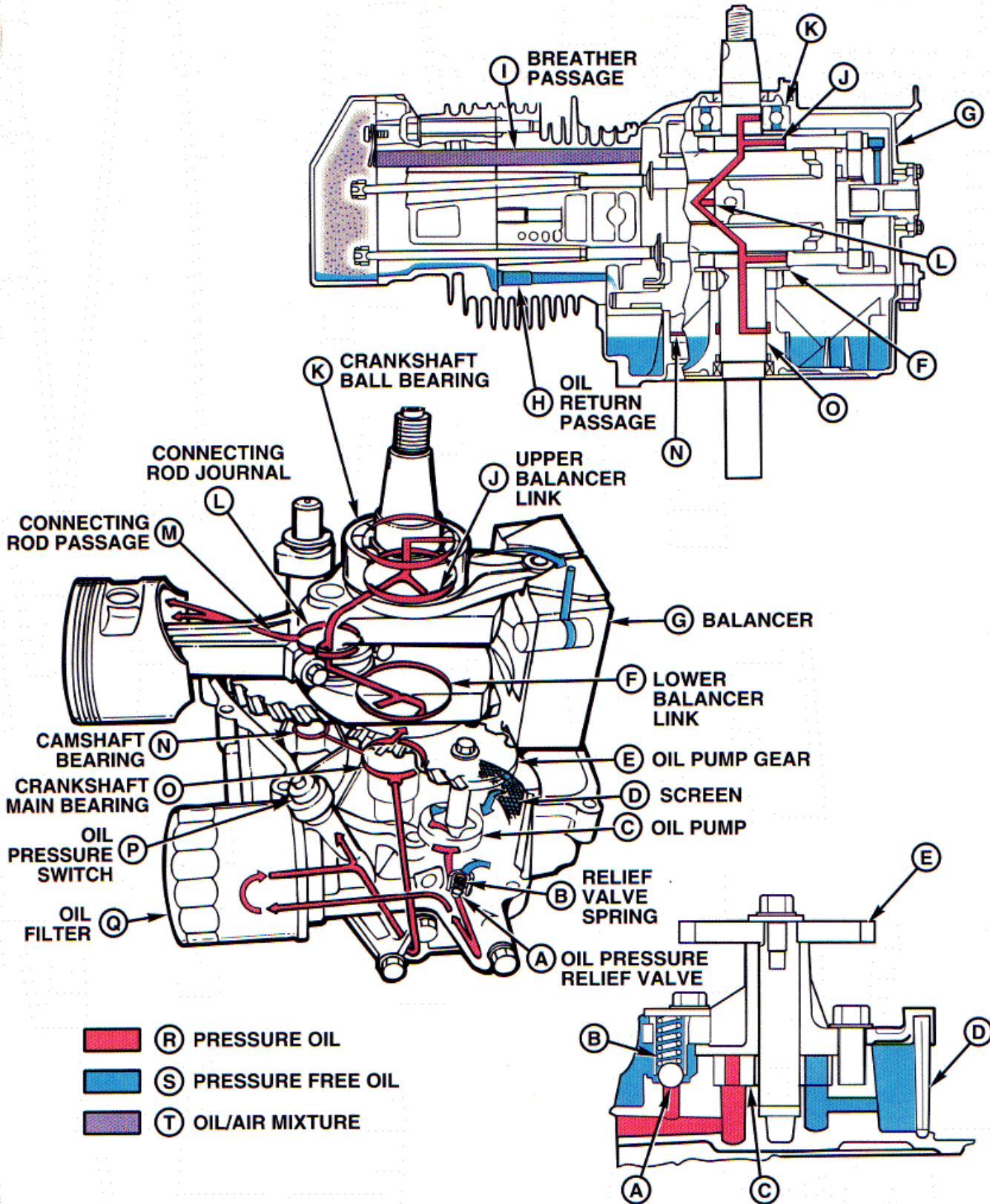

LUBRICATION SYSTEM

M48880

-19-
 220
 10
 5
 MXC48880

MX,22010CL,6 -19-04MAY92

ENGINE LUBRICATION CIRCUIT

A—Engine Lubrication Circuit

B—High Pressure Oil

C—Return/Pressure-Free Oil

D—Oil Filter

E—Engine Oil Pressure Relief

F—Engine

G—Oil Pump

H—Oil Pump Screen

I—Sump

J—Transaxle

The F510 (PA420A) and F525 (PA540A) engines utilize a common sump (I) supplying oil for engine and hydrostatic transaxle needs. The sump is an

integral part of the transaxle casting. (See Lubrication System Operation in this section for further information.)

MX,22010CL,7 -19-23OCT95

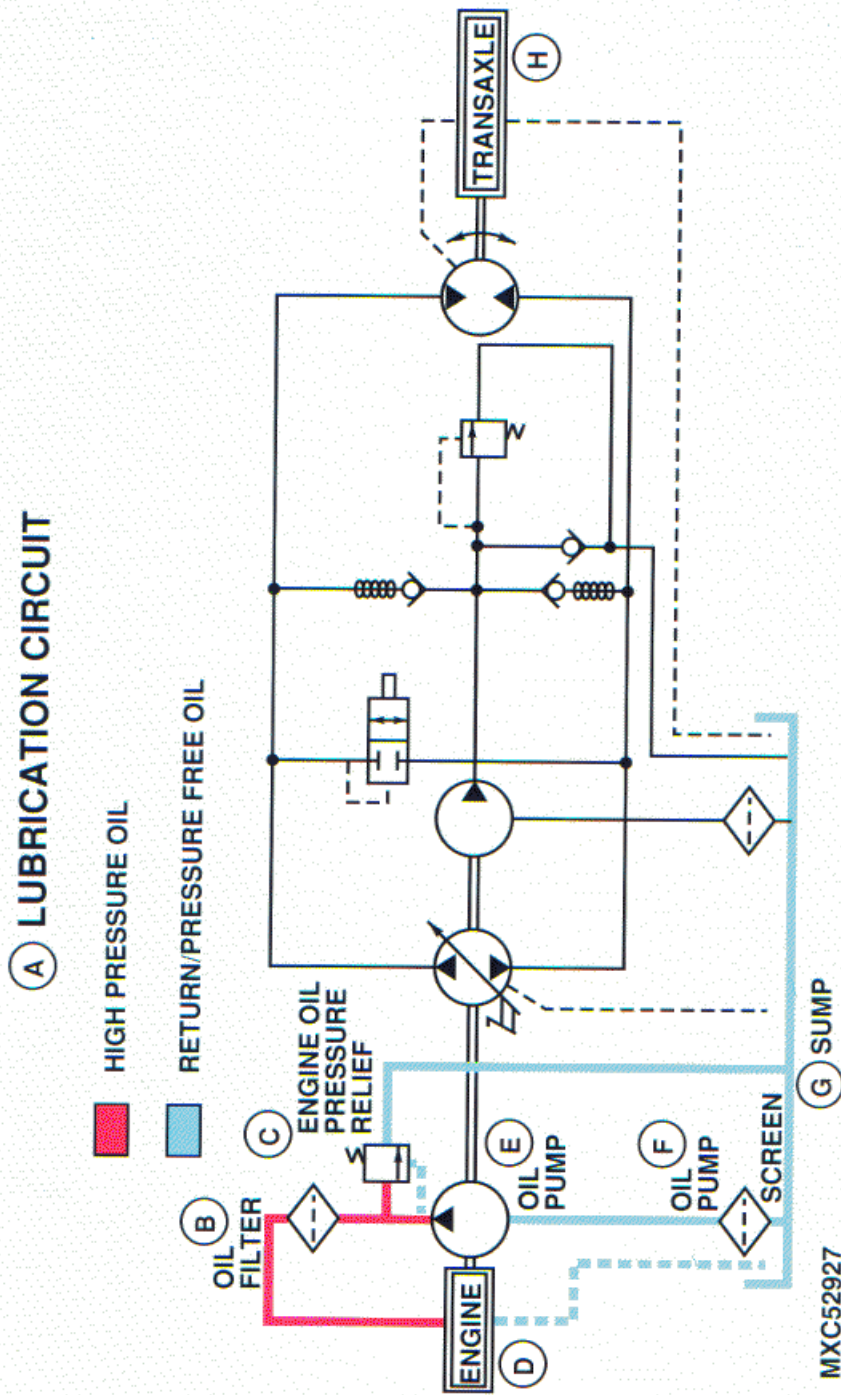

BREATHER SYSTEM OPERATION

Function:

Maintain a vacuum in the crankcase to prevent oil leaks.

Major Components:

- Breather Valve
- Maze
- Breather Passage
- Oil Return Passage

Theory of Operation:

The engine is equipped with a breather system that allows air to escape easily from the engine, but restricts air coming in. As the piston moves downward during power and intake strokes the volume of the crankcase (H) decreases. To prevent a buildup of pressure, oil-laden air flows through the

breather passage (F) and breather valve (D) into the space under the rocker arm cover (E). In order to prevent excess oil loss, the air is routed through a maze (C) in the rocker arm cover where the oil separates out. The non-oily air then passes through breather hose (B) and into the air cleaner housing (A) between the air filter and the carburetor. The separated oil lubricates the valve train and returns to the crankcase through the oil return passage (G). When the piston moves upward during compression and exhaust strokes, the volume of the crankcase increases. Crankcase vacuum increases and closes the breather valve preventing air flow into the crankcase. A restriction (I) and oil in the oil return passage also help to limit air flow into the crankcase. The result is that a small vacuum is maintained in the crankcase.

MX,22010CL,9 -19-23OCT95

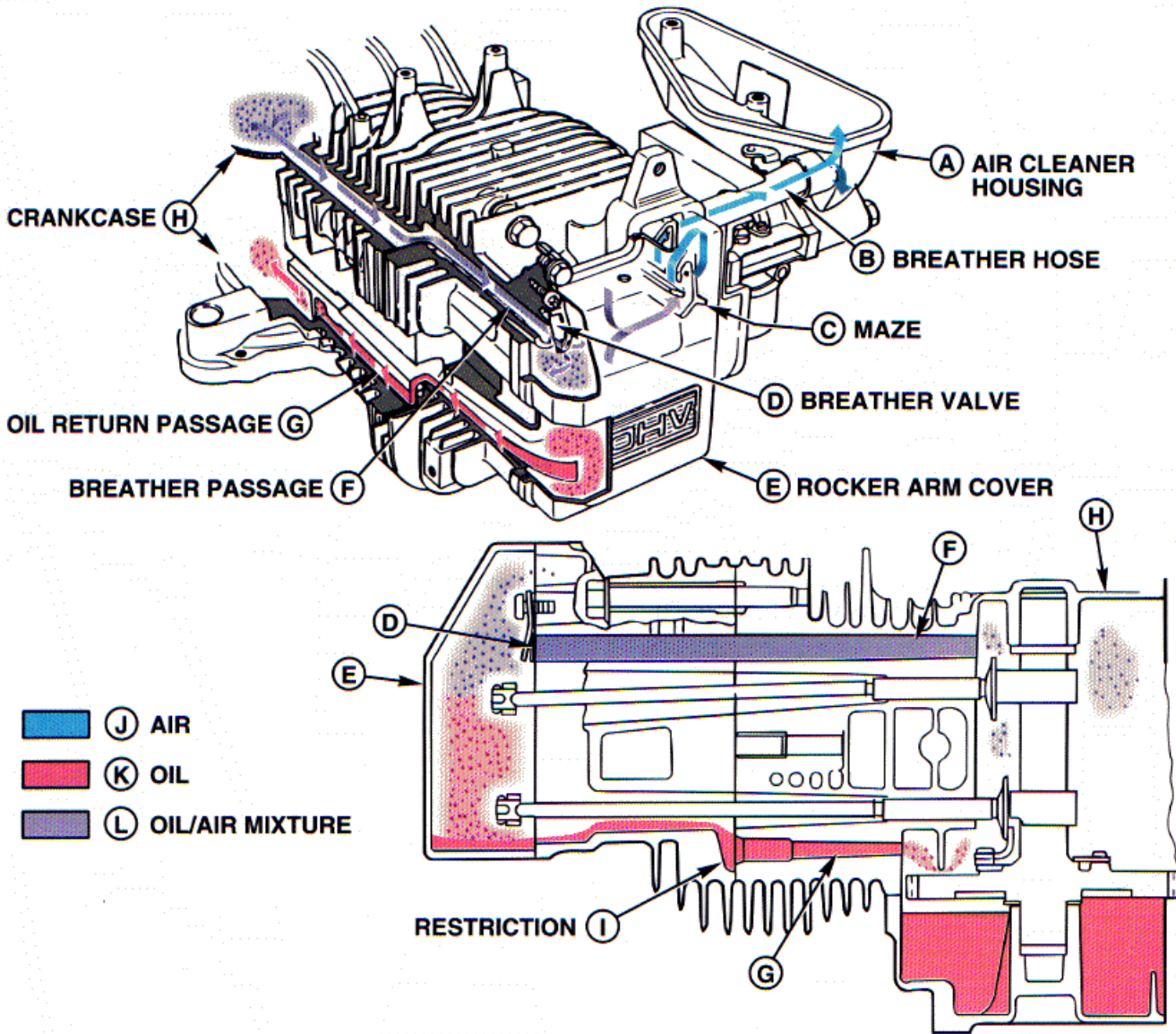

BREATHER OPERATION

MXC48883

A—Air Cleaner Housing
B—Breather Hose
C—Maze

D—Breather Valve
E—Rocker Arm Cover
F—Breather Passage

G—Oil Return Passage
H—Crankcase
I—Restriction

J—Air
K—Oil
L—Oil/Air Mixture

MX,22010CL,10 -19-23OCT95

MXC48883 -19-

COOLING SYSTEM

Function:

Remove heat from engine.

Major Components:

- Intake Screen
- Flywheel Fan
- Engine Covers
- Cooling Fins

Theory of Operation:

The engine is air cooled with air flow provided by a fan (A) that is a part of the flywheel. During operation, the fan draws air in through the intake screen (B). The intake screen rotates and cuts debris into small pieces to help prevent the cooling fins from plugging. The blower housing (C) and cylinder block covers (F) then direct the air flow past the cooling fins (D) of the cylinder block and head. Most of the cooling air flows through passages in the cylinder head (E) directly over the valve area. This increased cooling capacity in the valve area helps to minimize valve sticking and seat wear from overheating. The

cooling fins are cast into the engine block and cylinder head to increase their surface area to allow more of the heat generated by the engine to be transferred to the cooling air.

On F510 (S.N. 100204—) and F525 (S.N. 100393—), a hole and duct in the blower housing direct cooling air flow over the fuel pump. The engine shroud or crankcase has several holes added to it directly in front of the air cleaner to allow cooling air flow over the carburetor. The cooling air flow decreases fuel temperature in the fuel pump and carburetor to help prevent vapor lock.

It is important that the intake screen remains free from debris for proper air flow. The engine covers should not be removed or altered, as cooling capacity will be reduced. Cylinder block and head cooling fins must remain clean to properly dissipate heat. Debris build-up on the intake screen or fins will affect the volume of air setting to the carburetor.

MX,22010CL,11 -19-23OCT95

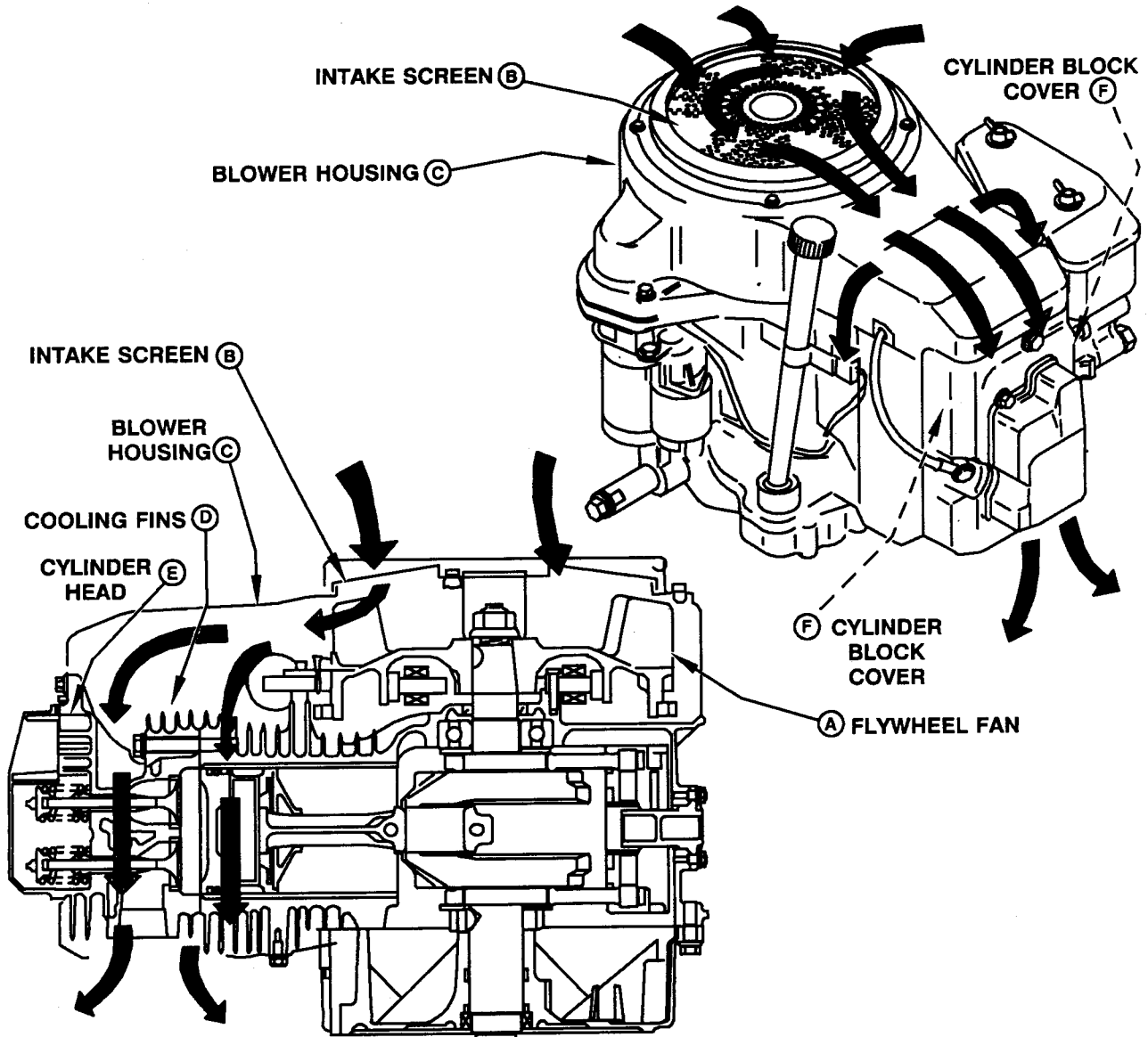

M45628

COOLING SYSTEM

A—Flywheel Fan
B—Intake Screen

C—Blower Housing
D—Cooling Fins

E—Cylinder Head

F—Cylinder Block Cover

M45628 -19-07SEP90

MX,22010CL,12 -19-23OCT95

220
10
11

AUTOMATIC COMPRESSION RELEASE

Function:

To lower engine compression for easier starting.

Major Components:

- Fly-Weights
- Spring
- Tab

Theory of Operation:

The automatic compression release uses fly-weights and a tab to slightly lift the exhaust valve which releases engine compression. The compression release assembly is attached to the camshaft and cannot be serviced separately.

With the engine cranking, the fly-weights (A) are held inward by spring (C) tension. A tab (G) that is connected to one of the fly-weights moves up (away from camshaft) as the fly-weights pivot inward. In this position the tab is held above the camshaft heel (E).

During the compression stroke, with the engine cranking, the tab contacts the exhaust valve lifter (F) and holds it off the camshaft heel a small amount until just before TDC. This opens the exhaust valve slightly just after the intake valve closes to release some compression for easier starting. A stop pin (B) locks the fly-weight and tab in the upper position to prevent the tab from being pushed down by the exhaust valve lifter.

When the engine starts and the engine speed is about 600-900 rpm, centrifugal force moves fly-weight (I) outward unlocking the fly-weight and tab from the stop pin. Now the fly-weights (H and I) overcome the force of the spring and pivot outward until they contact stop pin (B). The release tab moves down (toward camshaft) below the camshaft heel until it no longer holds up the exhaust valve lifter and the engine runs with full compression.

MX,22010CL,13 -19-23OCT95

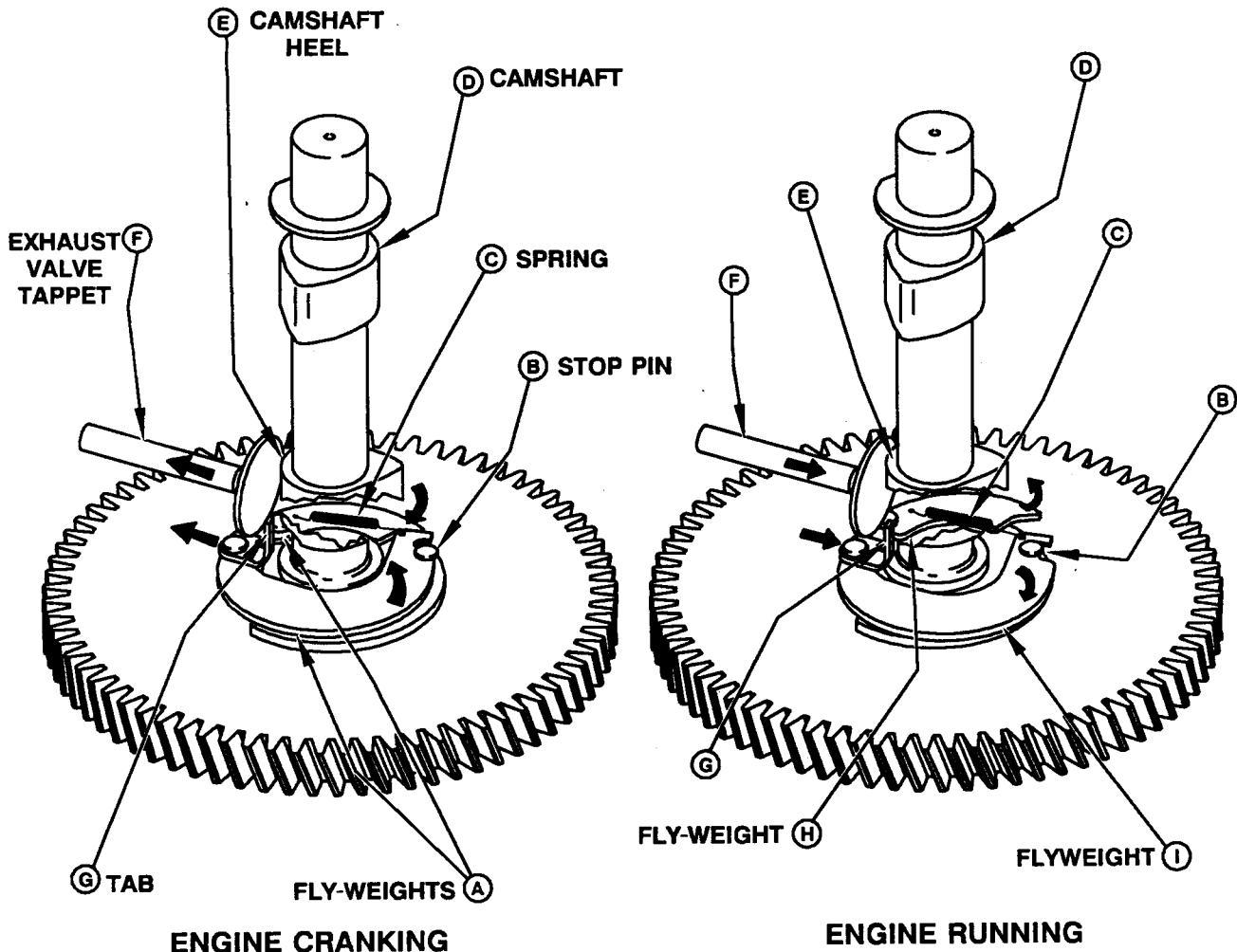

M48882

AUTOMATIC COMPRESSION RELEASE

A—Fly-Weights
B—Stop Pin
C—Spring

D—Camshaft
E—Camshaft Heel
F—Exhaust Valve Lifter

G—Compression Release
Tab

H—Fly-Weight
I—Fly-Weight

MX,22010CL,14 -19-23OCT95

M48882 -19-06AUG90

220
10
13

DIAGNOSTIC INFORMATION

The diagnostic information in this group is used to test components related to a specific problem. Select the appropriate symptom from the list that best matches your problem and follow the test procedures under that heading. The symptom headings are:

- Engine cranks but will not start
- Engine flooding
- Lack of fuel in carburetor
- Engine starts hard or stops when hot
- Engine surging
- Engine backfires through carburetor
- Engine backfires through muffler when shut OFF
- Engine misses
- Engine loses power or runs rough when hot
- Engine has black exhaust smoke
- Engine has blue exhaust smoke or oil in air cleaner
- Engine uses too much oil

The diagnostic procedure lists:

- Test conditions
- Test sequence
- Test location
- Normal reading
- Check or test to perform if reading is not normal

When performing the test or check, be sure to set your machine up to the test conditions listed and follow the sequence carefully. The middle "NORMAL" column gives the specification or condition that should be obtained when performing the test or check. If the results are not normal, perform the test, check, or adjustment listed in the third "IF NOT NORMAL" column to repair the malfunction. The detailed tests or adjustments referred to in the "IF NOT NORMAL" column are located at the end of this group.

The system diagram that accompanies each test procedure shows the machine components. The key number on the art matches the number in the "TEST LOCATION" column and the arrow shows the exact point where the test is to be made.

ENGINE CRANKS BUT WILL NOT START

Conditions:

- Transmission in neutral
- Park brake engaged
- PTO disengaged
- Key switch in "START" position

Test Location	Normal	If Not Normal
1. Spark plug	Fuel check - spark plug dry	See Engine Flooding tests in this group.
2. Spark plug	Spark test indicates steady blue spark	See Ignition Circuit Test Points in Section 240, Group 15.
3. Carburetor drain screw	Fuel present in float bowl when screw is opened	See Lack of Fuel in Carburetor tests in this group.
4. Fuel shut-off solenoid (key switch-run position)	Solenoid must click or with solenoid removed, plunger must retract	Test fuel shut-off solenoid.
5. Carburetor choke plate and choke linkage	Choke adjustment - choke plate fully closed with throttle lever in full choke position	Adjust choke.
	Choke linkage must move freely	Repair choke linkage.
6. Cylinder - spark plug hole	Minimum compression 483 kPa (71 psi)	Perform Compression Leak Check.
7. Intake and exhaust valve	Valve clearance - 0.15 mm (0.006 in.)	Adjust valve clearance.
8. Starter	Minimum cranking rpm - 350 rpm	Perform Automatic Compression Release (ACR) Check.
	Maximum starter amp draw: PA420A - 60 amps at 500 rpm PA540A - 85 amps at 500 rpm	Perform Starter No-Load Average and RPM Test in Section 240, Group 15.
9. Internal components	Components move freely, bearings and bushings not damaged	Repair internal components.

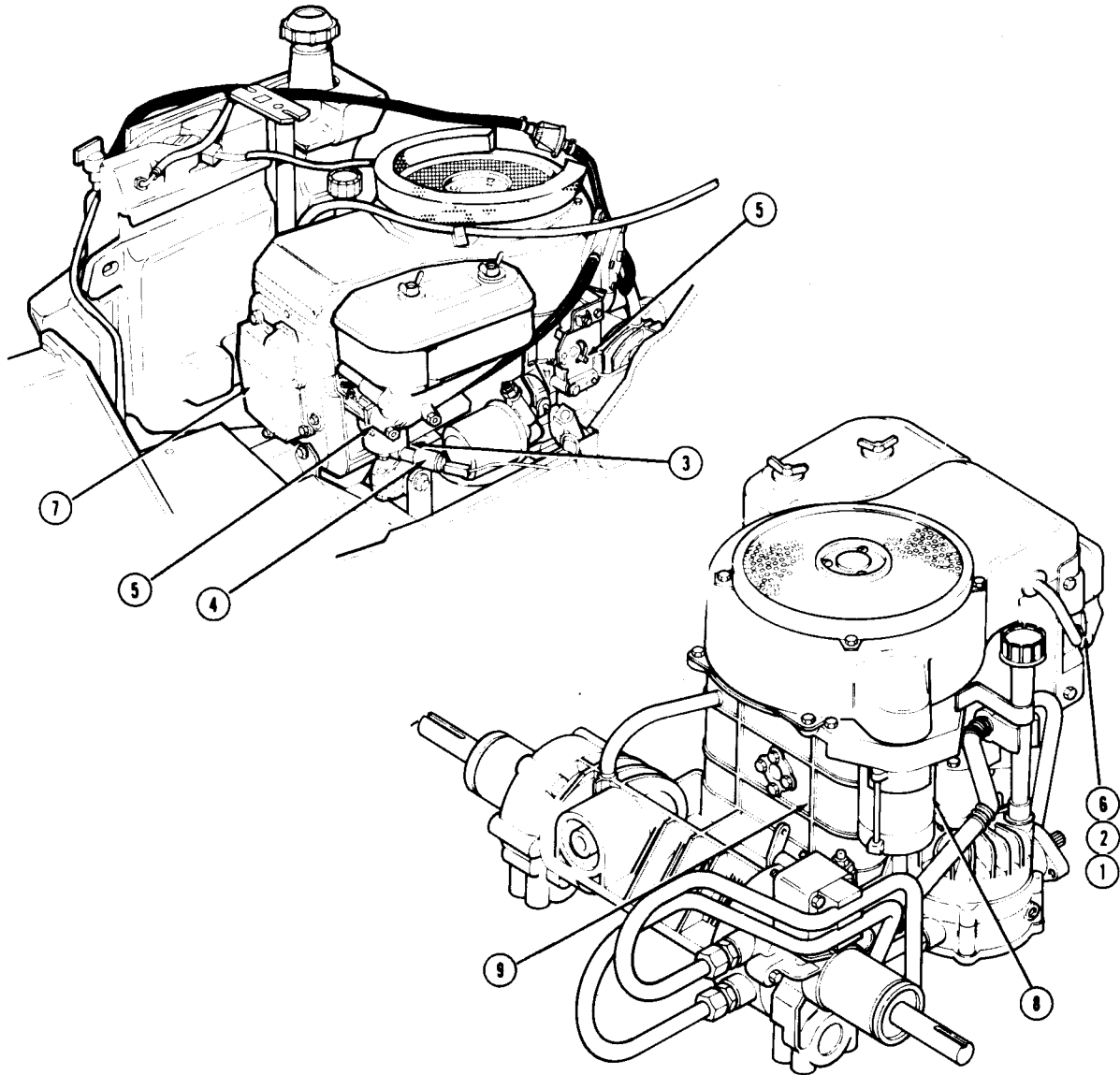

M45926

ENGINE CRANKS BUT WILL NOT START

MX,22015CL,3 -19-23OCT95

M45926 -19-11JUN91

ENGINE FLOODING

Conditions:

- Transmission in neutral
- Park brake engaged
- PTO disengaged

Test Location	Normal	If Not Normal
1. Carburetor choke plate and choke linkage	Choke plate fully open with throttle arm in fast idle position - throttle control arm screw/choke arm gap - 0.25—3 mm (0.01—0.12 in.) Choke linkage must move freely	Adjust choke. Repair choke linkage.
2. Spark plug	Spark test indicates steady blue spark	See Ignition Circuit Test Points in Section 240, Group 15.
3. Carburetor - check low idle mixture	Smooth idle at 1450 ±100 RPM	Adjust idle mixture screw. Adjust low idle speed.
4. Air cleaner assembly	Not restricted or damaged	Replace filter assembly.
5. Governor arm and shaft - governor adjustment	Governor arm and shaft must be at full clockwise position with throttle at fast idle	Adjust governor.
6. Carburetor float and float position	No fuel inside float, float parallel with body	Replace float.
7. Carburetor - inspect inlet needle and seat	Not dirty, not worn	Clean or replace needle and seat.
8. Fuel pump	Minimum pressure - 6 kPa (0.9 psi) at 3400 rpm	Check crankcase vacuum. Repair fuel pump.

MX,22015CL,4 -19-23OCT95

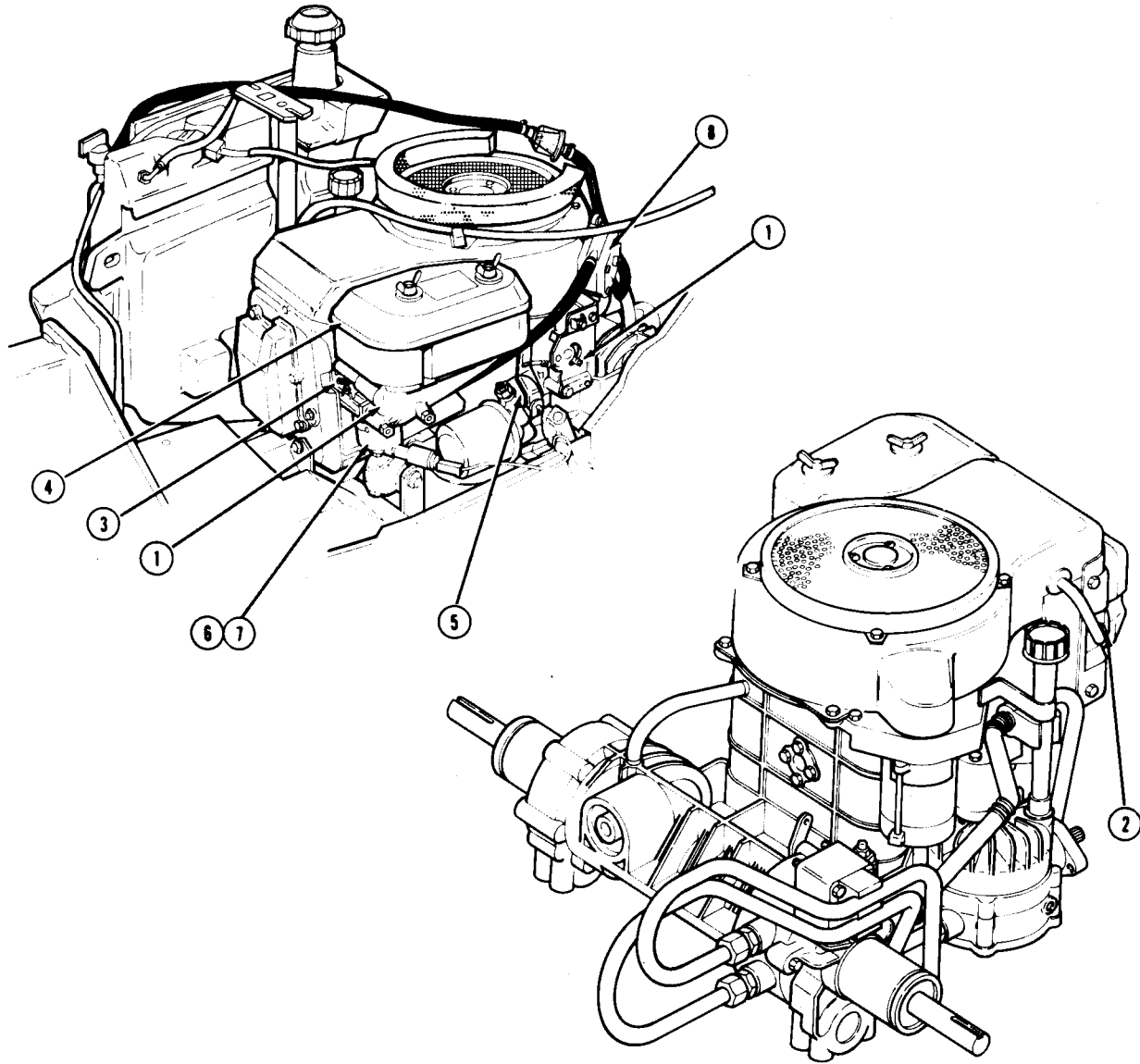

M45927

ENGINE FLOODING

MX,22015CL,5 -19-23OCT95

M45927 -19-11JUN91

220
15
5

LACK OF FUEL IN CARBURETOR

Conditions:

- Transmission in neutral
- Park brake engaged
- PTO disengaged

Test Location	Normal	If Not Normal
1. Fuel tank, fuel shut-off valve, filter, lines, and carburetor - check for external leaks	No leakage or damage	Repair leaks or components.
2. Fuel tank vent line - check for plugged condition	No restrictions	Clean or replace fuel tank vent line.
3. Fuel pump supply line - remove and check for fuel	Fuel present	A. Inspect shut-off valve. B. Inspect filter. C. Inspect fuel line.
4. Fuel pump	Minimum pressure - 6 kPa (0.9 psi) at 3350 RPM	Test crankcase vacuum. Repair fuel pump. repair fuel pump.
5. Carburetor needle valve, needle seat	Needle must move freely, free from varnish or debris	Clean or replace needle and seat.
6. Fuel line to carburetor - replace with a clear line and watch for air bubbles that indicate vapor lock	No air bubbles	Insulate lines. Try fresh fuel.

MX,22015CL,6 -19-23OCT95

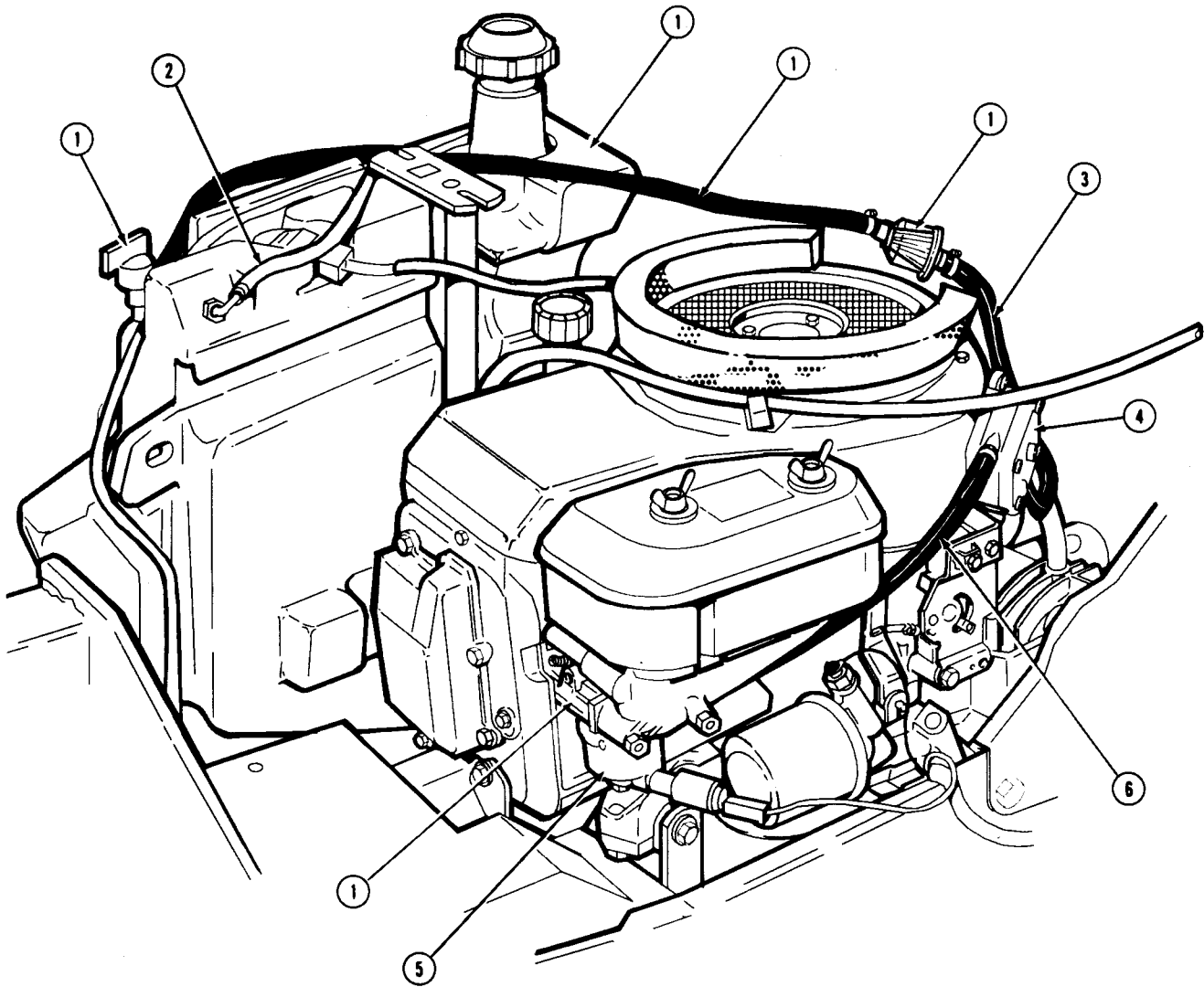

M45928

LACK OF FUEL IN CARBURETOR.

MX,22015CL,7 -19-23OCT95

M45928 -19-11JUN91

ENGINE STARTS HARD OR STOPS WHEN HOT

Conditions:

- Transmission in neutral
- Park brake engaged
- PTO disengaged
- Engine hot

Test Location	Normal	If Not Normal
1. Spark plug	Fuel check - spark plug dry	See Engine Flooding tests in this group.
2. Spark plug	Spark test indicates steady blue spark	See Ignition Circuit Tests in Section 240, Group 15.
3. Carburetor drain screw	Fuel present in float bowl when drain screw is opened	See Lack of Fuel in Carburetor in this group.
4. Fuel shut-off solenoid (key switch-run)	Solenoid must click or with solenoid removed, plunger must retract	Test fuel shut-off solenoid.
5. Fuel pump supply line - hook up external fuel supply to known good fuel	No change in engine performance	Drain system and add fresh fuel.
6. Cylinder - spark plug hole	Minimum compression - 483 kPa (71 psi)	Perform Compression Leak Check in this group.
7. Intake and exhaust valves	Valve clearance - 0.15 mm (0.006 in.) Valves not sticking when hot	Adjust valve clearance. Check valve guides and stems.
8. Exhaust valve - check automatic compression release by turning crankshaft slowly	Exhaust valve must open minimum of 0.25 mm (0.01 in.) just after intake valve closes	Replace camshaft.
9. Flywheel - inspect key	Nut torqued to 86 N·m (63 lb-ft), key and keyways not damaged	Tighten nut. Replace key or other damaged components.

MX,22015CL,8 -19-23OCT95

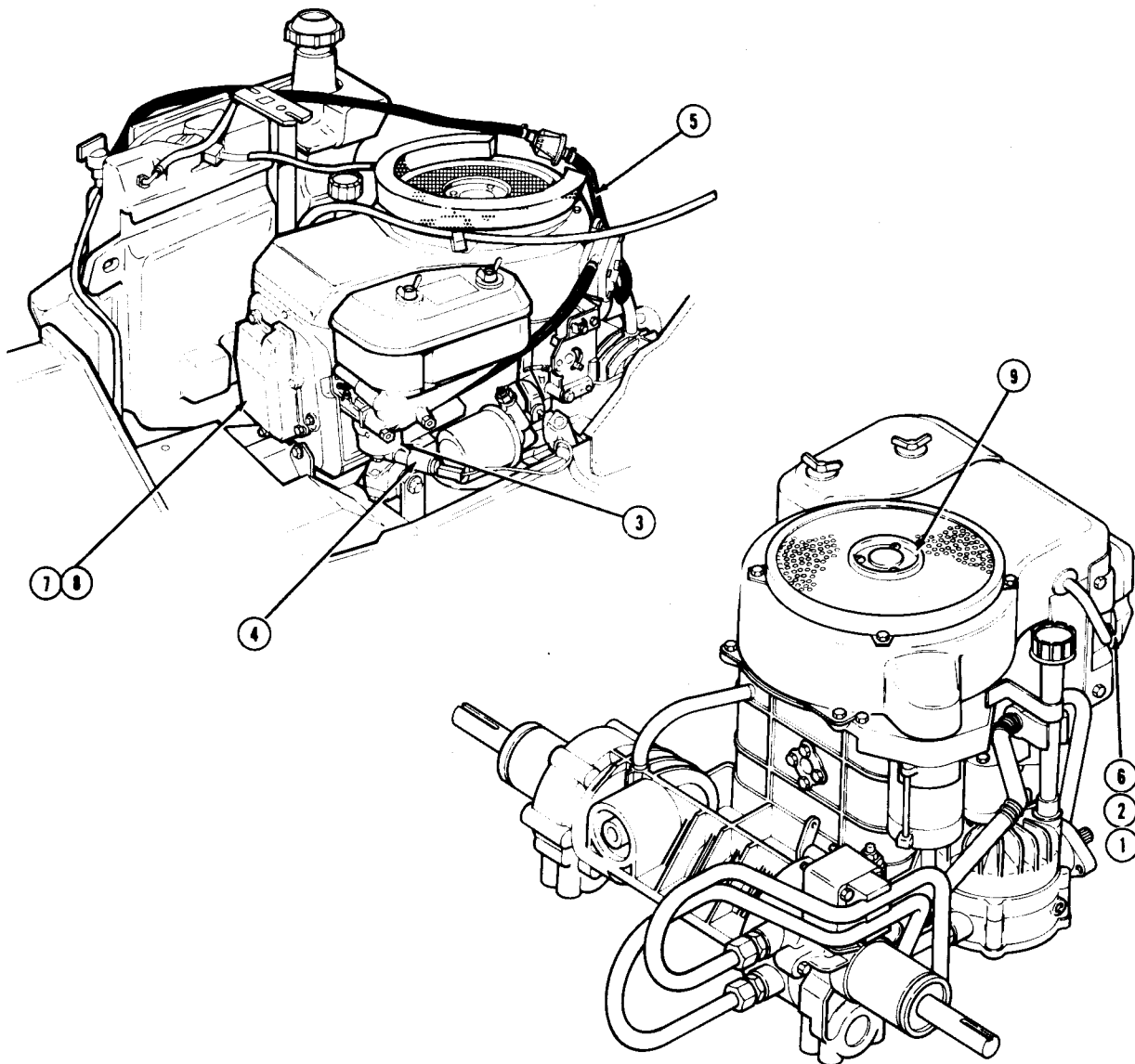

M45929

ENGINE STARTS HARD OR STOPS WHEN HOT

MX,22015CL,9 -19-23OCT95

M45929 -19-11JUN91

ENGINE SURGING

*NOTE: Surging is usually the result of a lean mixture
(not enough fuel or too much air)*

Conditions:

- Transmission in neutral
- Park brake engaged
- PTO disengaged

Test Location	Normal	If Not Normal
1. Fuel tank - remove cap while engine is running	No change in engine performance	Clean or replace fuel tank vent line.
2. Air cleaner cover - remove cover while engine is running	No change in engine performance - engine still surging	If surging stops, clean engine cooling fins and blower housing.
3. Carburetor choke plate and choke linkage	Choke plate fully open with throttle arm in fast idle position - throttle -throttle control arm screw/arm gap - 0.25—3 mm (0.01—0.12 in.)	Adjust choke.
	Choke linkage must move freely	Repair choke linkage.
4. Carburetor - check low idle mixture	Smooth idle at 1450 ±100 rpm	Adjust idle mixture screw. Adjust low idle speed screw.
5. Governor arm and shaft - governor adjustment	Governor arm and shaft must be at full clockwise position with throttle at fast idle	Adjust governor.
	Governor linkage must move freely	Repair governor linkage.
6. Carburetor gaskets (air intake) - spray aerosol lubricant around gaskets while engine is running	No change in engine performance (engine still surging)	If engine stops surging, an intake air leak is indicated - replace gaskets.
7. Fuel pump	Minimum pressure - 6 kPa (0.9 psi) at fast idle	Check crankcase vacuum. Repair fuel pump.
8. Carburetor - inspect all internal passages, check float position	No varnish or debris	Clean passages.
	Float parallel with body	Replace float.

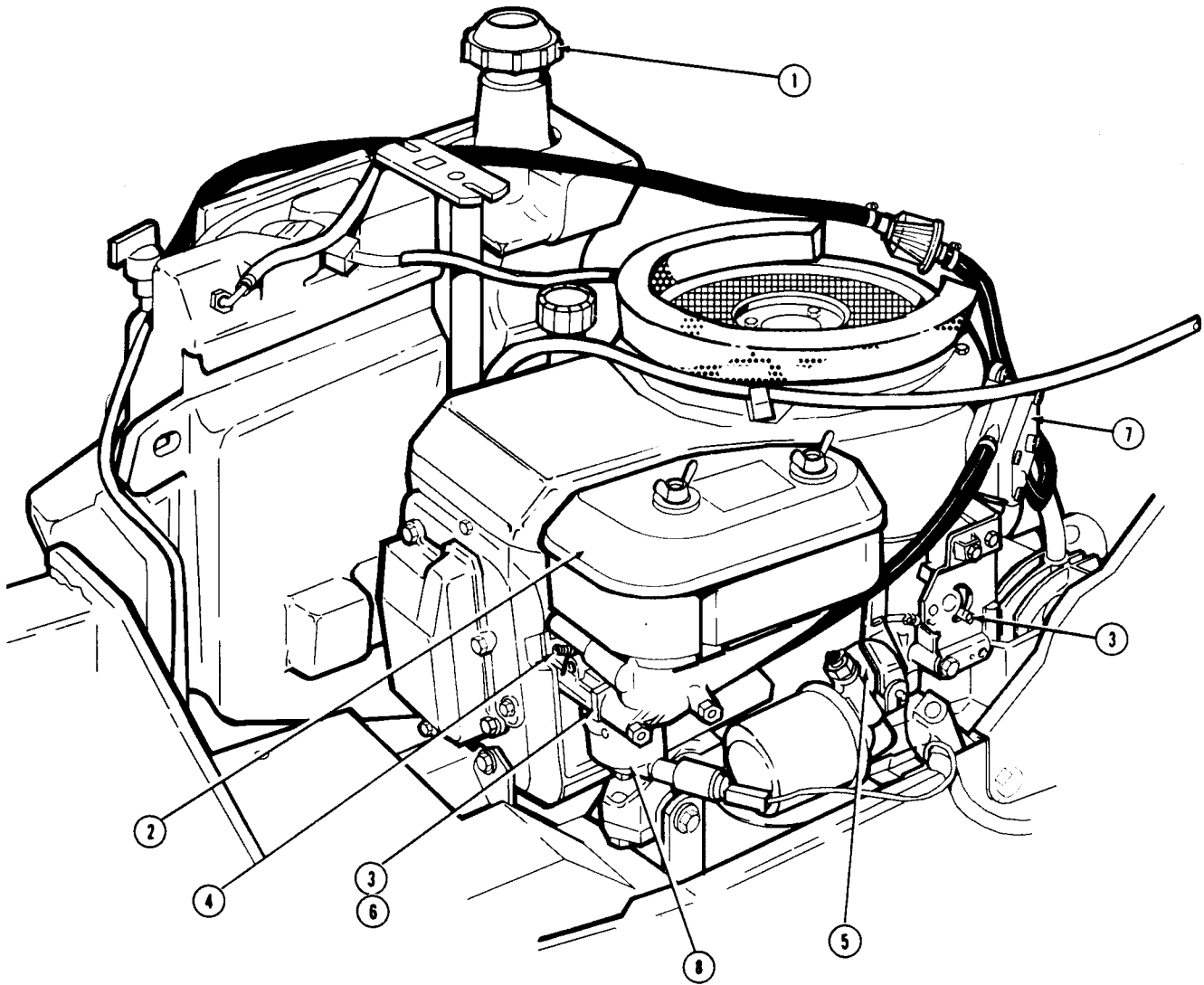

M45930

ENGINE SURGING

MX,22015CL,11 -19-23OCT95

M45930 -19-11JUN91

220
15
11

ENGINE BACKFIRES THROUGH CARBURETOR

Conditions:

- Transmission in neutral
- Park brake engaged
- PTO disengaged

Test Location	Normal	If Not Normal
1. Spark plug	Spark test indicates steady blue spark, spark plug not fouled	Replace spark plug then see Ignition Circuit Tests in Section 240, Group 15.
2. Carburetor choke plate and choke linkage	Choke plate fully open with throttle arm in fast idle position - throttle control arm screw/choke arm gap - 0.25—3 mm (0.01—0.12 in.)	Adjust choke.
	Choke linkage must move freely	Repair linkage.
3. Carburetor - check low idle mixture	Smooth idle at 1450 ±100 rpm	Adjust idle mixture screw.
4. Intake and exhaust valves	Valve clearance - 0.15 mm (0.006 in.)	Adjust valve clearance.
	Valves not sticking	Check valve guides and stems.
5. Valves - check valve lift	Both open same amount	Replace camshaft.
6. Ignition coil	Air gap - 0.3 mm (0.012 in.)	Adjust ignition coil air gap.
7. Flywheel - inspect key	Nut tightened to 86 N·m (63 lb-ft)	Tighten nut.
	Key and keyways not damaged	Replace key or other damaged components.

MX,22015CL,12 -19-23OCT95

ENGINE BACKFIRES THROUGH CARBURETOR

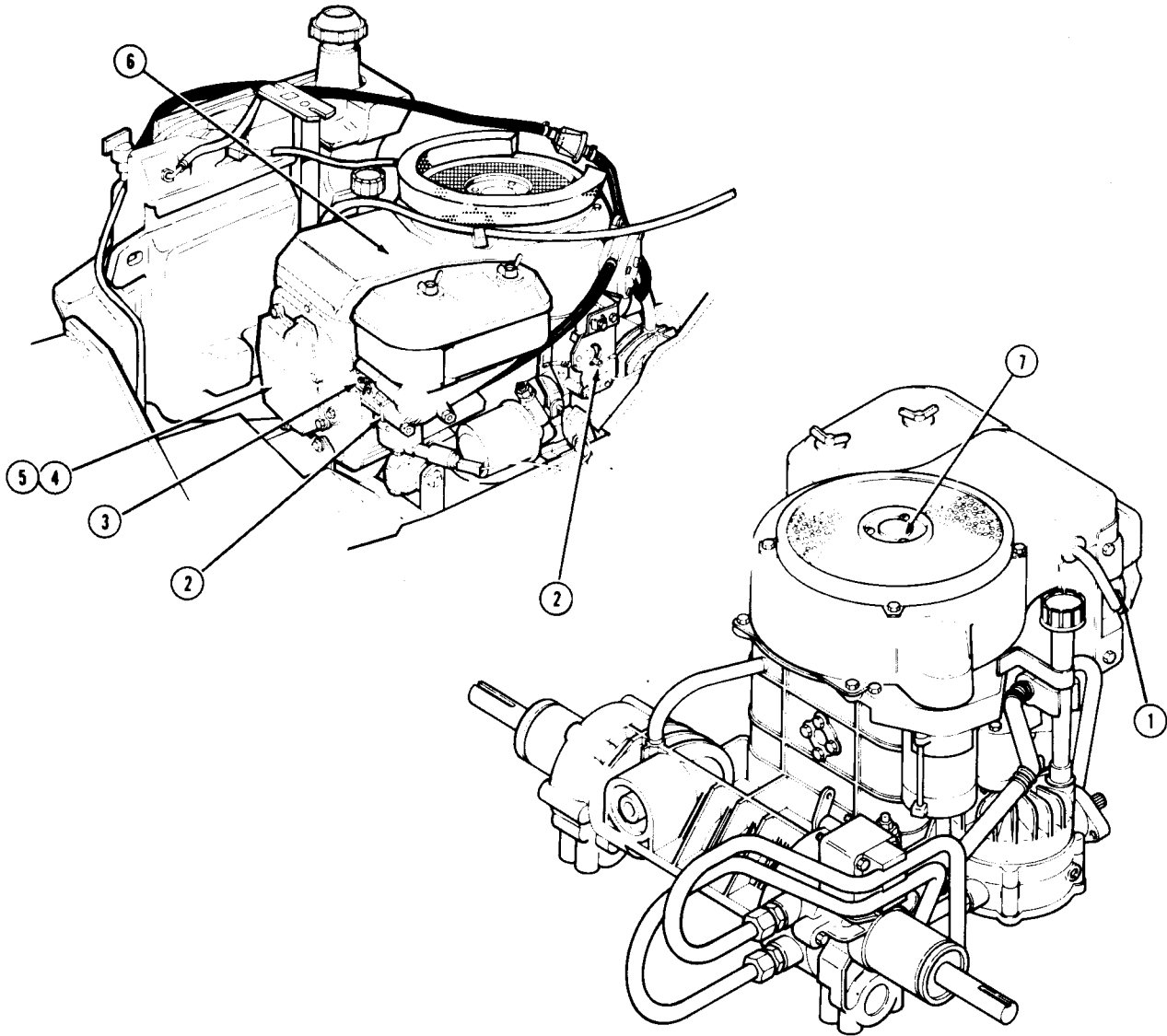

M45931

ENGINE BACKFIRES THROUGH CARBURETOR

M45931
-19-11JUN91

MX,22015CL,13 -19-23OCT95

220
15
13

ENGINE BACKFIRES THROUGH MUFFLER WHEN ENGINE IS SHUT OFF

NOTE: Allow engine to idle for 15 seconds before shutting engine off.

Conditions:

- Transmission in neutral
- Park brake engaged
- PTO disengaged

Test Location	Normal	If Not Normal
1. Fuel shut-off solenoid (key switch-run-off)	Solenoid must click or with solenoid removed, plunger must retract. With key switch off, plunger must extend	Test fuel shut-off solenoid.
	Plunger must move freely, plunger tip and carburetor seat not worn or damaged	Replace fuel shut-off solenoid.
2. Air cleaner assembly	Not restricted or damaged	Replace filter assembly.
3. Carburetor slow idle stop screw	Slow idle speed - 1450 ±100 rpm	Adjust slow idle stop screw.
4. Carburetor - check low idle mixture adjustment	Smooth idle at 1450 ±100 rpm	Adjust idle mixture screw.
5. Ignition coil	Resistance: Primary winding 0.48 to 0.72 ohm Secondary winding 10.9 to 16.3 K ohm	Replace ignition coil.
	Air gap - 0.3 mm (0.012 in.)	Adjust ignition coil air gap.
6. Ignition module - try a different one	Makes no difference in operation	Replace ignition module.
7. Muffler	No damage or hot spots, no rattle if shaken	Replace muffler.

MX,22015CL,14 -19-23OCT95

ENGINE BACKFIRES THROUGH MUFFLER WHEN ENGINE IS SHUT OFF

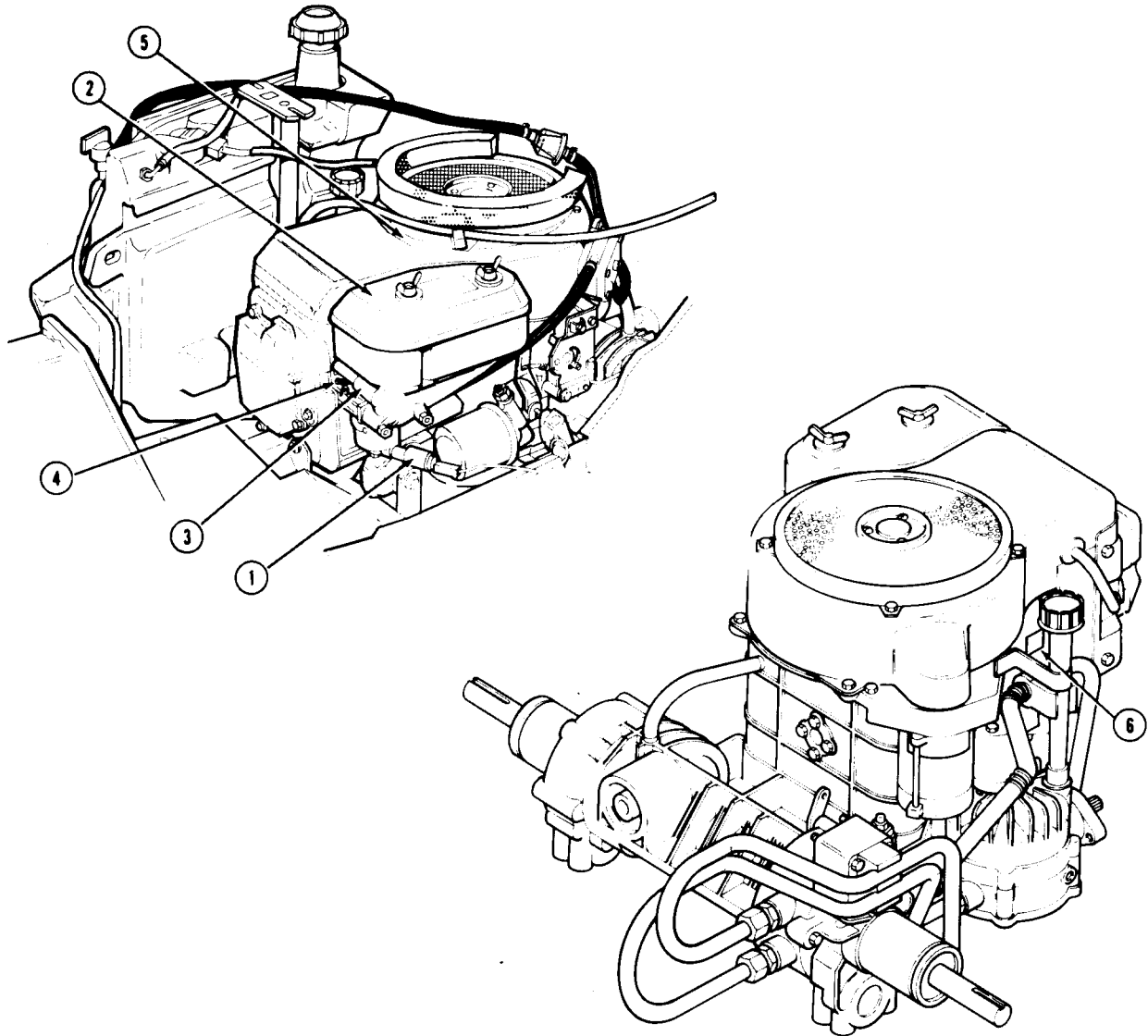

M45932

ENGINE BACKFIRES THROUGH MUFFLER WHEN ENGINE IS SHUT OFF

M45932 -19-11JUN91

MX,22015CL,15 -19-23OCT95

220
15
15

ENGINE MISSES

Conditions:

- Transmission in neutral
- Park brake engaged
- PTO disengaged

Test Location	Normal	If Not Normal
1. Spark plug	Condition - not fouled, brown color Air gap - 0.76 mm (0.030 in.)	Clean or replace plug. Adjust gap.
2. Spark plug	Fuel check - spark plug dry	See Engine Flooding tests in this group.
3. Carburetor choke plate and choke linkage	Choke plate fully open with throttle arm in fast idle position - throttle control arm screw/choke arm gap - 0.25—3 mm (0.01—0.12 in.) Choke linkage must move freely	Adjust choke. Repair choke linkage.
4. Fuel pump supply line - connect external supply of known good fuel.	No change in engine performance	Drain system and add fresh fuel.
5. Carburetor - check low idle mixture adjustment	Smooth idle at 1450 ±100 rpm	Adjust low idle speed screw. Adjust low idle mixture screw.
6. Intake and exhaust valves	Valve clearance - 0.15 mm (0.006 in.) Valves not sticking	Adjust valve clearance. Check valve guides and stems.
7. Valves - check valve lift	Both open same amount	Replace camshaft.
8. Carburetor - check float position	Float parallel with body	Replace float.
9. Ignition coil	Resistance: primary winding 0.48 to 0.72 ohm secondary winding 10.9 to 16.3 K ohm Air gap - 0.3 mm (0.012 in.)	Replace ignition coil. Adjust ignition coil air gap.
10. Ignition module - replace with another module	Makes no difference in operation	Replace ignition module.
11. Flywheel - inspect key	Nut tightened to 86 N·m (63 lb-ft) key and keyways not damaged	Tighten nut. Replace key or other damaged components.

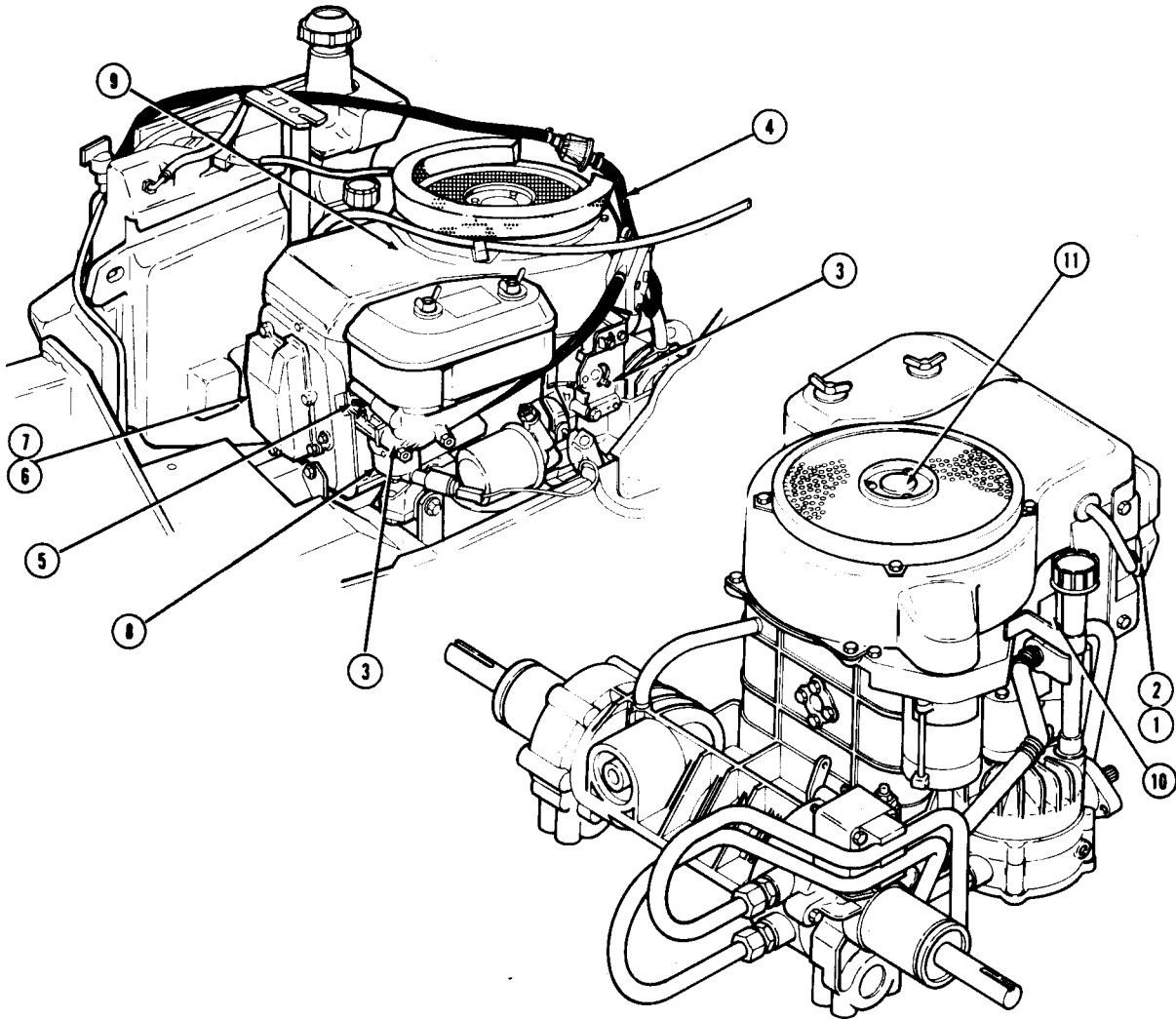

M45933

ENGINE MISSES

MX,22015CL,17 -19-23OCT95

M45933 -19-11JUN91

ENGINE LOSES POWER OR RUNS ROUGH WHEN HOT

Conditions:

- Transmission in neutral
- Park brake engaged
- PTO disengaged
- Engine hot

Test Location	Normal	If Not Normal
1. Air cleaner assembly	Not restricted or damaged	Replace assembly.
2. Fuel tank - remove cap while engine is running	No change in engine performance	Clean or replace fuel tank vent line.
3. Fuel pump supply line - remove and check for fuel flow	Open flow of fuel	Inspect shut-off valve. Inspect filter. Inspect fuel line.
4. Fuel line to carburetor - replace with clear line and watch for air bubbles that indicate vapor lock	No air bubbles	Try different fuel. Insulate lines.
5. Fuel pump	Minimum pressure 6 kPa (0.09 psi) at 3350 ±75 rpm	Test crankcase vacuum. Replace pump.
6. Governor arm and shaft - governor adjustment	Governor arm and shaft in full clockwise position with throttle at fast idle	Adjust governor.
7. Ignition coil	Resistance: Primary winding 0.48 to 0.72 ohm Secondary winding 10.9 to 16.3 K ohm Air gap - 0.3 mm (0.012 in.)	Replace ignition coil. Adjust ignition coil air gap.
8. Carburetor - inspect all internal passages	No varnish or debris	Clean passages.
9. Carburetor - check float position	Float parallel with body	Replace float.
10. Cylinder - spark plug hole	Minimum compression - 483 kPa (71 psi)	Perform Compression Leak Check.
11. Intake and exhaust valves	Valve clearance - 0.15 mm (0.006 in.) Valves not sticking	Adjust valve clearance. Check valve guides and stems.
12. Valves - check valve lift	Both open same amount	Replace camshaft.
13. Muffler - check for restrictions	No restrictions, no rattles	Replace muffler.

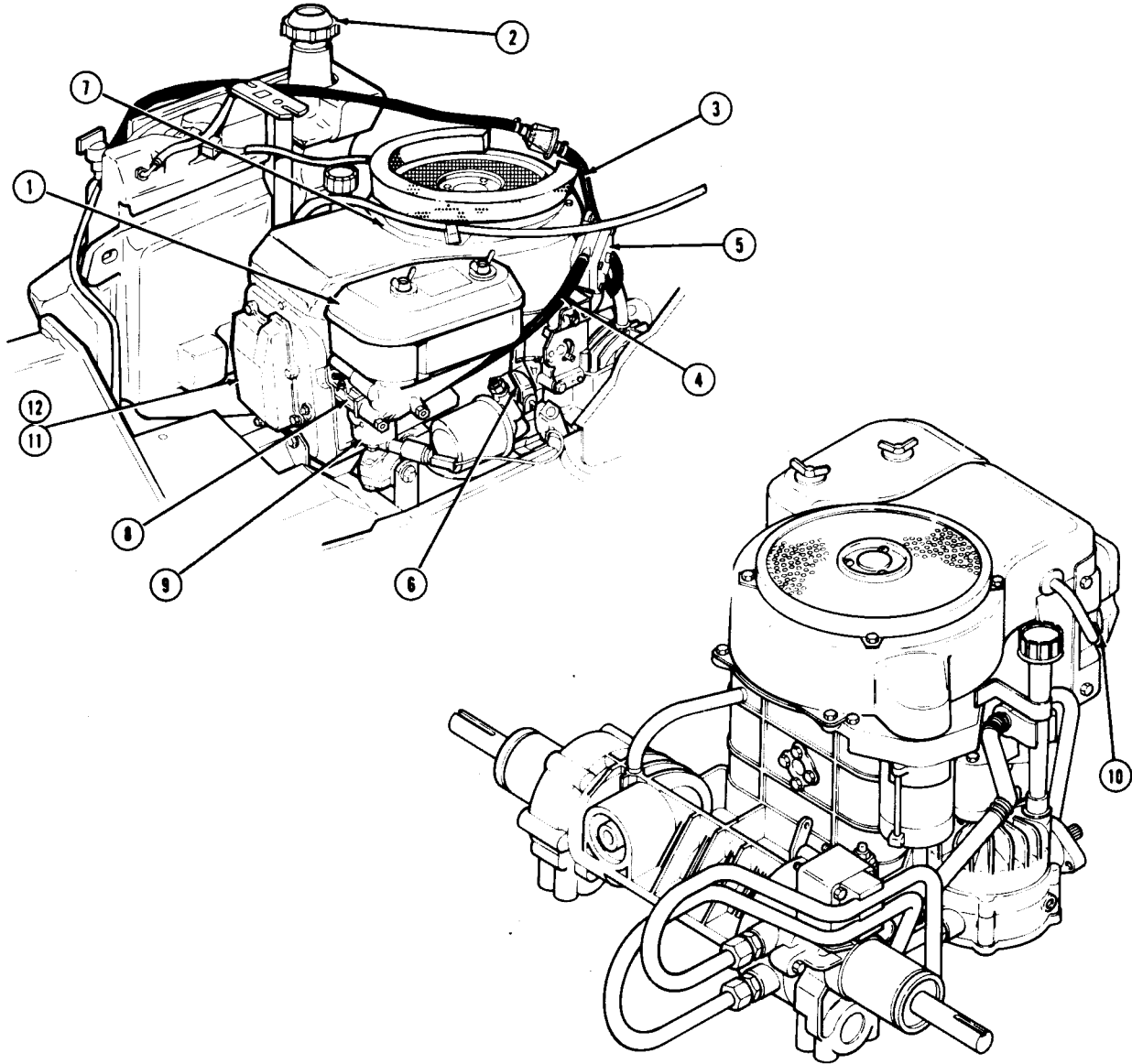

M45934

ENGINE LOSES POWER OR RUNS ROUGH WHEN HOT

M45934
-19-11JUN91

MX,22015CL,19 -19-23OCT95

ENGINE HAS BLACK EXHAUST SMOKE

Conditions:

- Transmission in neutral
- Park brake engaged
- PTO disengaged

Test Location	Normal	If Not Normal
1. Air cleaner assembly	Not restricted or damaged	Replace filter assembly.
2. Carburetor choke plate and choke linkage	Choke plate fully open with throttle arm in fast idle position - throttle control arm screw/choke arm gap - 0.25—3 mm (0.01—0.12 in.) Choke linkage must move freely	Adjust choke. Repair linkage.
3. Carburetor needle valve and needle seat	Needle must move freely, free from varnish or debris	Clean or replace needle and seat.
4. Carburetor float condition and float level	No fuel inside float, float parallel with body	Replace float.
5. Carburetor low idle mixture screw	Smooth idle at 1450 ±100 rpm, no black smoke	Adjust idle mixture screw.
6. Carburetor main jet	Size correct for elevation	Replace jet with correct size.
7. Carburetor pilot air jet passages	No debris	Clean passages.
8. Fuel pump	Minimum pressure - 6 kPa (0.09 psi) at fast idle	Test crankcase vacuum. Repair or replace fuel pump.

MX,22015CL,20 -19-23OCT95

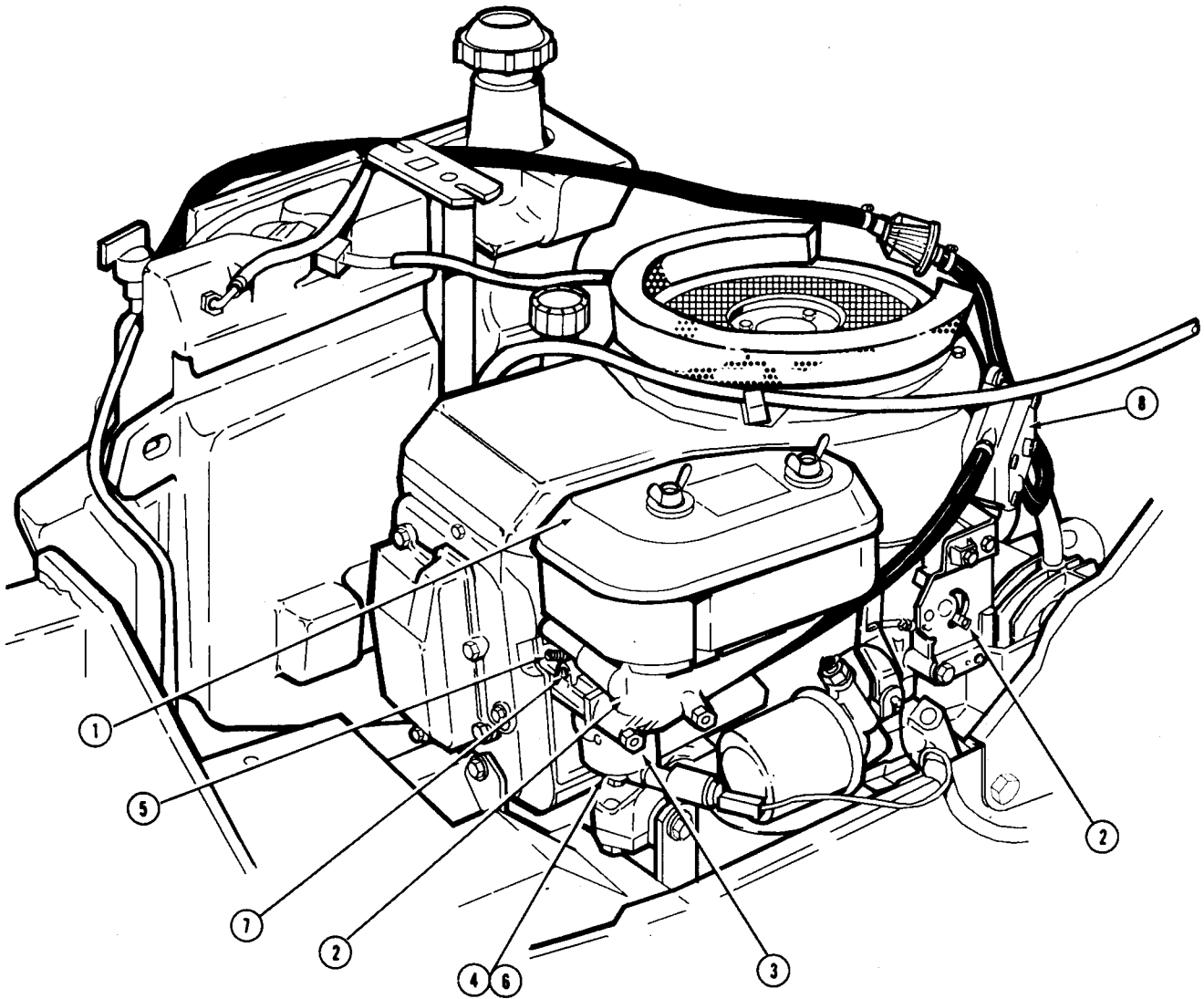

M45935

ENGINE HAS BLACK EXHAUST SMOKE

MX,22015CL,21 -19-23OCT95

M45935
-19-11JUN91

ENGINE HAS BLUE EXHAUST SMOKE OR OIL IN AIR FILTER HOUSING

Conditions:

- Transmission in neutral
- Park brake engaged
- PTO disengaged

Test Location	Normal	If Not Normal
1. Dipstick oil level	At or below full mark on dipstick	Drain oil (make sure fuel hasn't leaked into crankcase).
2. Dipstick O-ring seal, tube and cap	Not cracked, cut or leaking	Replace seal or components.
3. Dipstick tube, breather tube, and air cleaner	Minimum crankcase vacuum - 25 cm (10 in. water) at 3350 ±75 rpm	Check breather valve. Check engine seals and gaskets. Check engine compression.
	No oil visible in breather tube or air cleaner	Check breather oil return passage.
4. Intake screen, blower housing, and cooling fins	Not plugged with debris or cracked	Clean or replace components.
5. Breather valve	Maximum air gap - 1—2 mm (0.04—0.08 in.)	Replace breather reed valve.
	Reed valve and seat not cracked, distorted, or worn	Replace breather reed valve, cylinder head or block.
6. Breather valve passage	Passage not plugged or cracked	Clean or replace cylinder block or head.
7. Breather oil return passage - cylinder head and block	Not plugged or cracked	Clean or replace cylinder block or head.
8. Cylinder - spark plug hole	Minimum compression - 483 kPa (71 psi)	Perform Compression Leak Check.
9. Piston rings and cylinder bore	Wear within specifications no damage	Replace rings, piston or cylinder block.
10. Valve guides and seals	Wear within specifications no damage	Repair valve guides or seals.

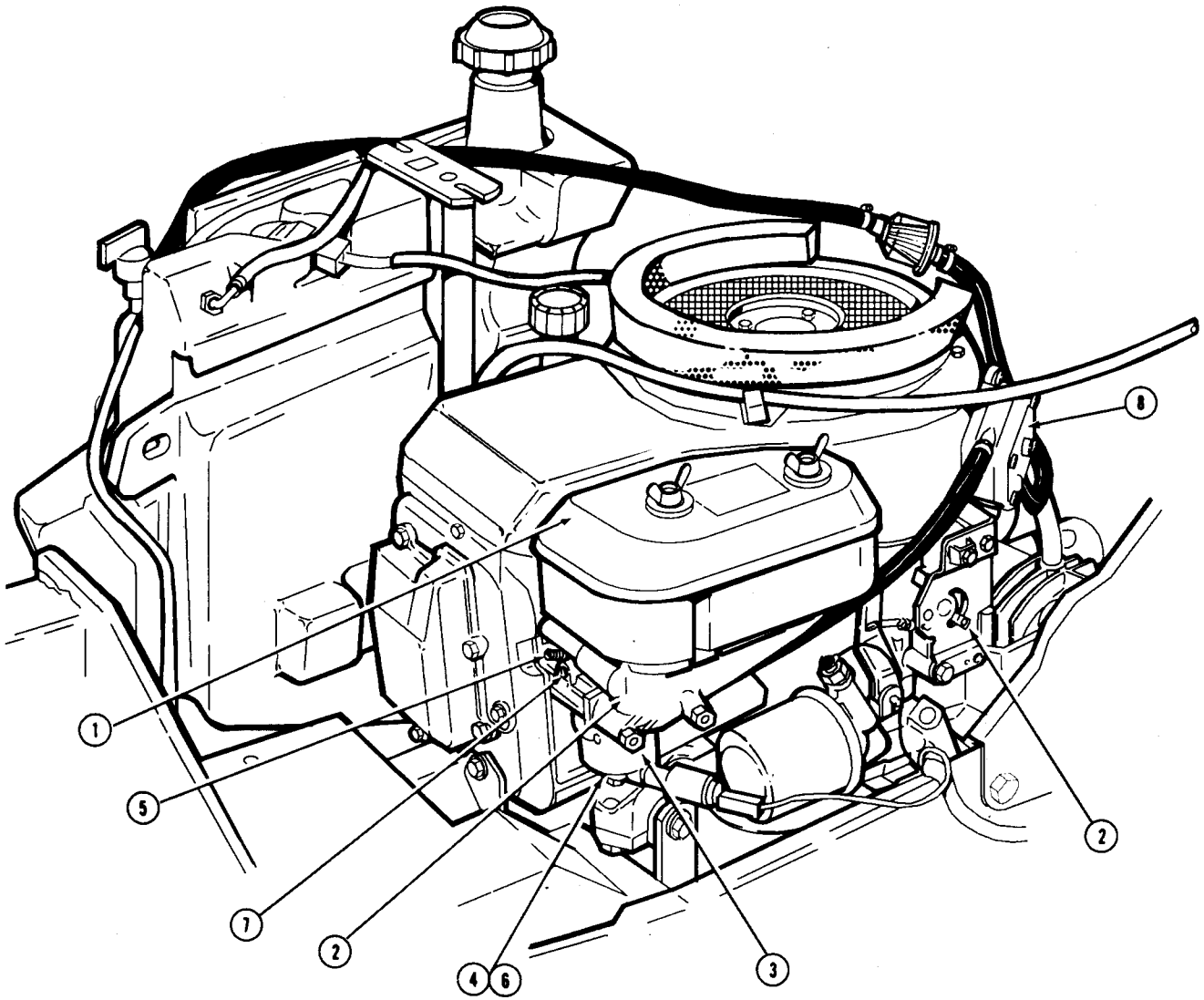

M45935

ENGINE HAS BLACK EXHAUST SMOKE

MX,22015CL,23 -19-23OCT95

M45936 -19-11JUN91

ENGINE USES TOO MUCH OIL

NOTE: 1. Oil consumption is too high if the oil level moves from full to add in less than 18 hours.

2. Oil level should always be checked after the engine has been run long enough to warm the oil. If the oil is checked cold then rechecked after warm up it is normal for the oil level to raise as much as 2 mm (0.08 in.) on the dipstick because of expansion.

Conditions:

- Transmission in neutral
- Park brake engaged
- PTO disengaged

Test Location	Normal	If Not Normal
1. Dipstick oil level	At or below full mark on dipstick	Drain oil (make sure fuel hasn't leaked into crankcase).
2. Engine oil seals and gaskets	No external leakage	Replace gaskets or seals.
3. Dipstick O-ring seal, tube and cap	Not cracked, cut or leaking	Replace seal or components.
4. Dipstick tube, breather tube, and air cleaner	Minimum crankcase vacuum - 17 cm (6.5 in. water) at 3350 ±100 rpm	Check breather valve. Check engine seals and gaskets. Check engine compression.
	No oil visible in breather tube or air cleaner	Check breather oil return passage.
5. Intake screen, blower housing, and cooling fins	Not plugged with debris or cracked	Clean or replace components.
6. Breather valve	Maximum air gap - 1—2 mm (0.04—0.08 in.)	Replace breather reed valve.
	Reed valve and seat not cracked, distorted, or worn	Replace breather reed valve, cylinder head or block.
7. Breather valve passage	Passage not plugged or cracked	Clean or replace cylinder block or head.
8. Breather oil return passage - cylinder head and block	Not plugged or cracked	Clean or replace cylinder block or head.
9. Cylinder - spark plug hole	Minimum compression - 483 kPa (71 psi)	Perform Compression Leak Check.
10. Piston rings and cylinder	Wear within specifications, no damage	Replace rings, piston or cylinder block.
11. Valve guides and seals	Wear within specifications, no damage	Repair valve guides or seals.
12. Internal engine components	Wear within specifications, no damage	Perform necessary engine repair.

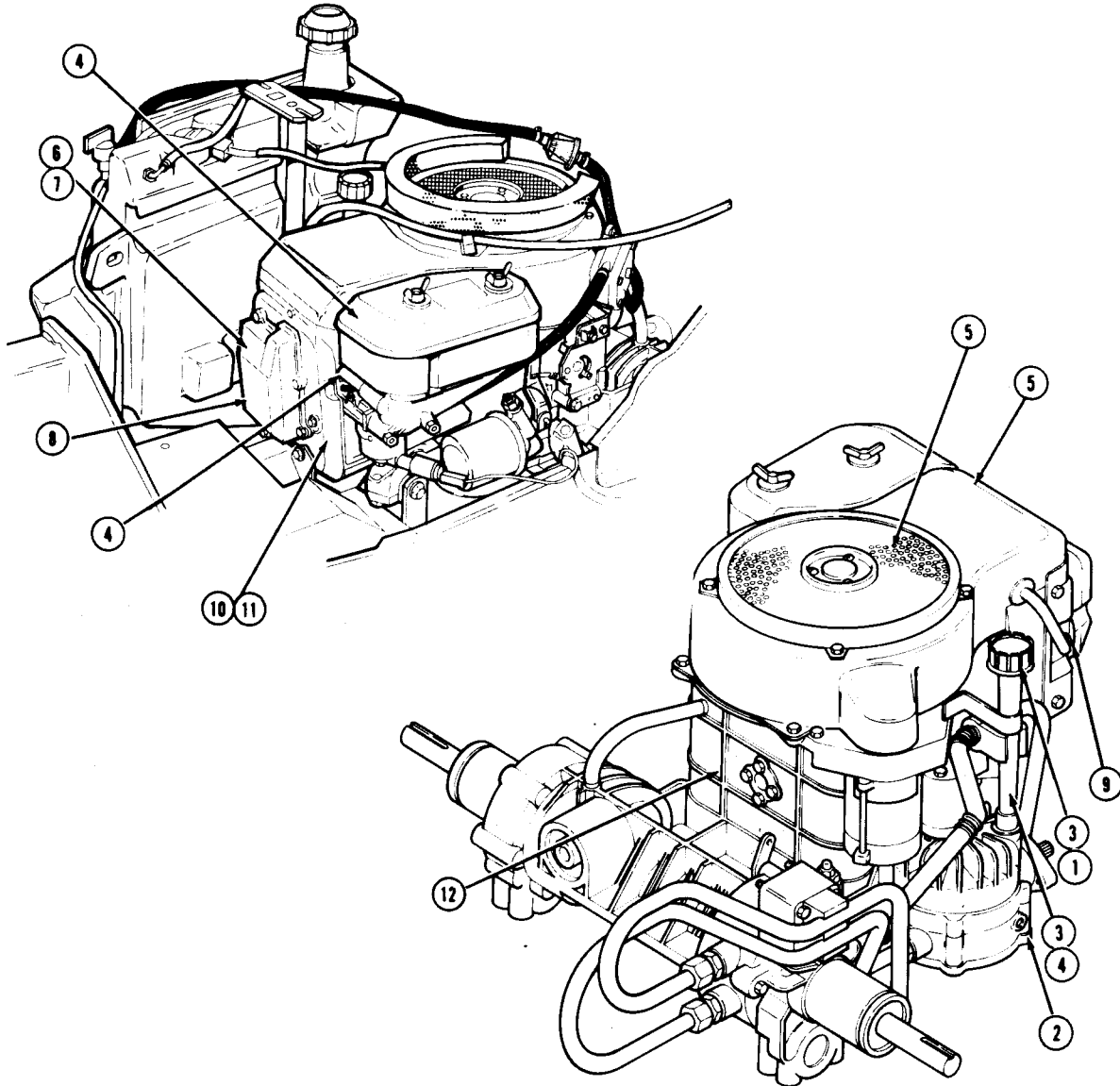

M45937

ENGINE USES TOO MUCH OIL

MX,22015CL,25 -19-23OCT95

M45937 -19-11JUN91

THROTTLE CABLE ADJUSTMENT

Reason:

To make sure the throttle control lever contacts the slow idle stop at **slow idle**.

Equipment:

- 6 mm (15/64-in.) Drill Bit or 45M7036 Pin

Procedure:

1. Move key switch to **OFF** position.
2. Put transaxle/transmission in **neutral**.
3. Engage park brake.
4. Raise and lock seat platform.
5. Raise rear shroud.
6. Move throttle lever to **fast idle** position.
7. Align hole in throttle control lever (A) with hole in throttle control plate (B). Put a 6 mm (15/64-in.) drill bit (C) or 45M7036 Pin through holes to keep the throttle control lever from moving. Be sure drill bit or pin is perpendicular to the throttle control plate.
8. Loosen cap screw (D) and pull throttle cable tight. Tighten cap screw.
9. Remove drill bit or pin.
10. For F510 (S.N. 100204—) and F525 (S.N. 100393—) only, move throttle lever to the **slow idle** position. Be sure the throttle control lever screw contacts the throttle control plate before the throttle lever bottoms out.
11. Move throttle lever through full range to be sure linkage is not binding.

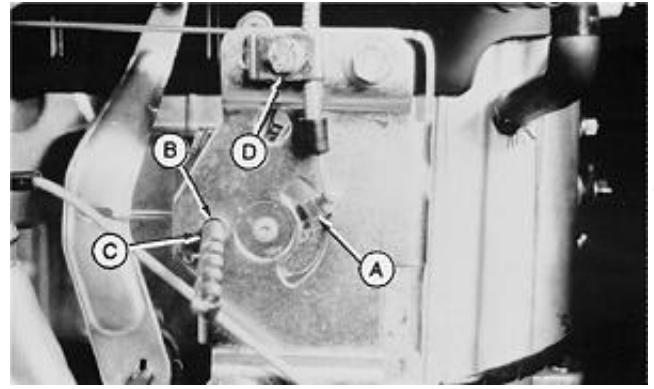

A—Throttle Control Lever
 B—Throttle Control Plate Hole
 C—6 mm (15/64 in.) Drill Bit
 D—Cap Screw

M70827 -UN-09AUG89

MX,22015CL,26 -19-23OCT95

CHOKE PLATE CHECK

Reason:

To make sure the choke plate is fully closed when the throttle lever is in the **full choke** position.

Procedure:

IMPORTANT: Check and adjust throttle cable before adjusting choke, to ensure accurate choke adjustment.

1. Check and adjust throttle cable.
2. Move throttle control lever to **full choke** position.
3. Try to move choke rod (A) toward carburetor (in direction of arrow). **Choke rod should NOT move.** If choke rod moves in direction of arrow, the choke plate is **not fully closed.**

Continued on next page

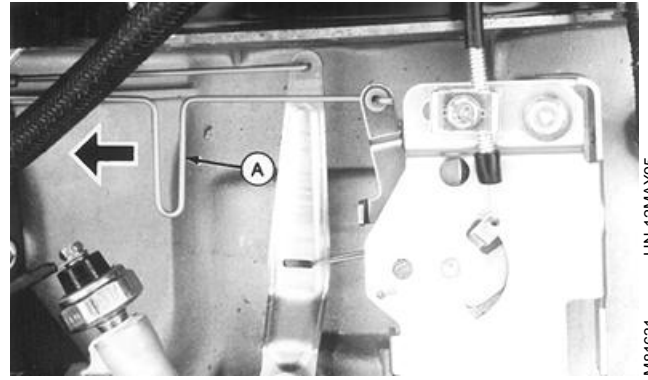

MX,22015CL,27 -19-23OCT95

4. Move throttle lever to **fast idle** position.

5. Check holes (E) in control panel (F) and throttle arm (D). **They MUST BE in visual alignment.** Check for gap between screw (B) and choke arm (C). Gap should be approximately **0.25—3 mm (0.01—0.12 in.)**.

6. Try to move choke rod (A) toward control panel (arrow). **Choke rod should NOT move.** If choke rod moves in direction of arrow, the choke plate is not fully open.

Results:

- If choke rod **DOES NOT** move in either direction with throttle control lever in specific positions, choke operation is OK.
- If choke rod **MOVES** in either direction with throttle control lever in the specific positions, perform Choke Plate Adjustment procedure.

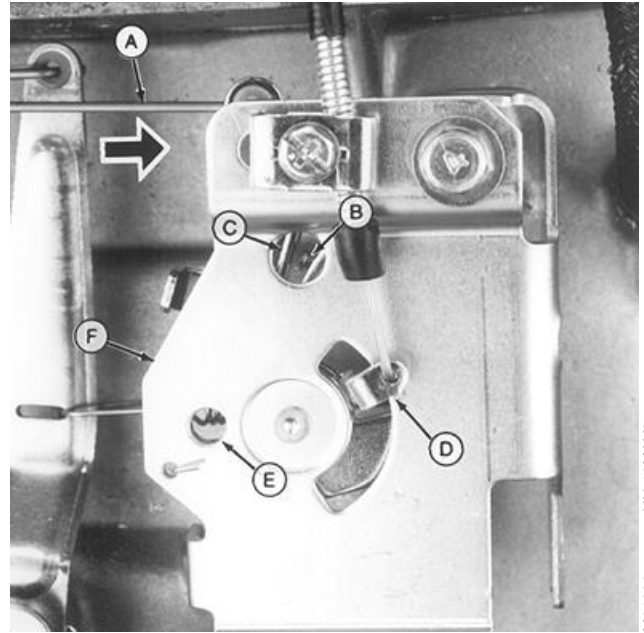

M81632
-JUN-12MAY95

- A—Choke Rod
- B—Adjustment Screw
- C—Choke Arm
- D—Throttle Control Arm
- E—Alignment Holes
- F—Throttle Control Panel

MX,22015CL,27A -19-23OCT95

CHOKE PLATE ADJUSTMENT

Procedure:

If choke plate is NOT closed when throttle control is in **full choke** position:

1. Move throttle control lever to **full choke** position.
2. Push and hold choke rod (A) toward carburetor (arrow) to close choke plate.
3. Insert a screwdriver through slot in control panel. Turn screw (B) (on backside of control panel) clockwise until it is **tight against choke arm (C)**.
4. Move throttle control lever to **fast idle** position.
5. Check for gap (D) between screw (B) and choke arm (C). Gap should be approximately **0.25—3 mm (0.01—0.12 in.)**.
6. Repeat CHECK procedure.

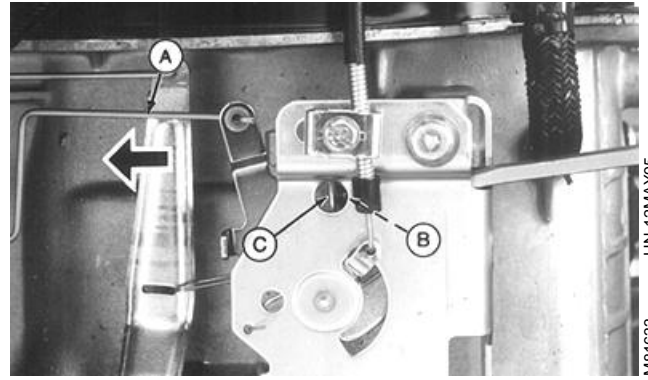

-JUN-12MAY95
M81633

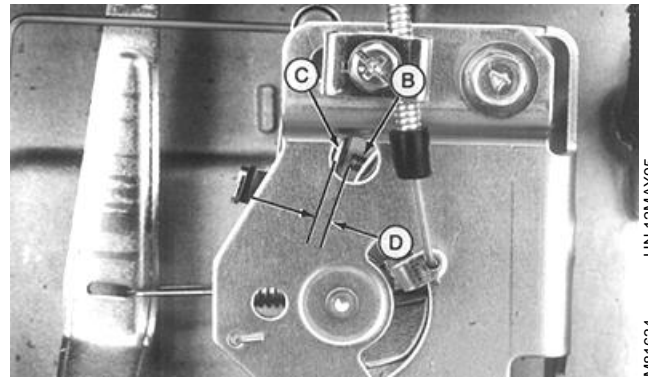

-JUN-12MAY95
M81634

MX,22015CL,27B -19-23OCT95

GOVERNOR ADJUSTMENT

Reason:

To make sure the governor shaft contacts the fly-weight plunger when the engine is stopped.

NOTE: Adjust throttle cable before adjusting governor linkage.

Procedure:

1. Move throttle lever to **fast idle** position.
2. Loosen nut (A).
3. Hold governor arm in the full right position. Turn governor shaft (B) **clockwise until governor shaft stops**. Hold governor shaft and tighten nut.
4. Move throttle lever through full range to be sure linkage is not binding.

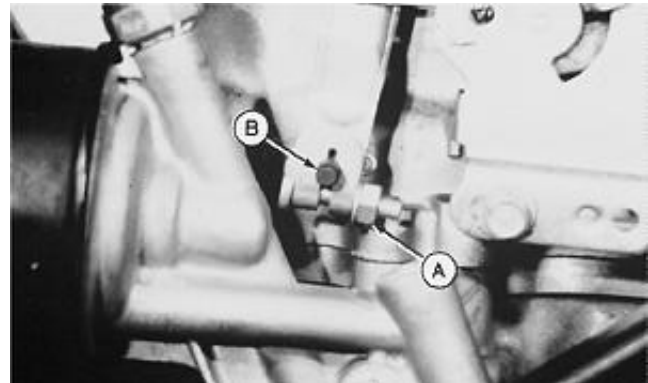

-JUN-21AUG89
M53172

MX,22015CL,28 -19-23OCT95

FAST IDLE SPEED ADJUSTMENT

Reason:

To set engine fast idle rpm.

Equipment:

- JTO5719 Photo Tachometer or JDM-71 Vibration Tachometer
- 6 mm (15/64-in.) Drill Bit or 45M7036 Pin

Procedure:

1. Move key switch to **OFF** position.
2. Put transaxle/transmission in **neutral**.
3. Engage park brake.
4. Raise and lock seat platform.
5. Raise rear shroud.
6. If using photo tachometer, put reflective tape on blower housing screen.
7. Start and run engine at **medium idle** for five minutes.



CAUTION: Engine will be HOT. Be careful not to burn hands.

8. Move throttle lever to **fast idle** position.
9. Align hole in throttle control lever (A) with hole in throttle control plate (B). Put a 6 mm (15/64-in.) drill bit or 45M7036 Pin through holes to keep the throttle control lever from moving. **Be sure drill bit or pin is perpendicular to the throttle control plate.**
10. Use JDM-71 Vibration Tachometer (A) on air cleaner or a photo tachometer to check engine rpm.

Specifications:

- **Fast idle speed setting .. 3350 ±75 rpm**

Results:

- If fast idle speed DOES NOT meet the specifications, loosen throttle control plate cap screws.
- Move throttle control plate forward to increase rpm or rearward to decrease rpm until **fast idle speed is 3350 ±75 rpm.**
- Hold the throttle control plate and tighten cap screws.

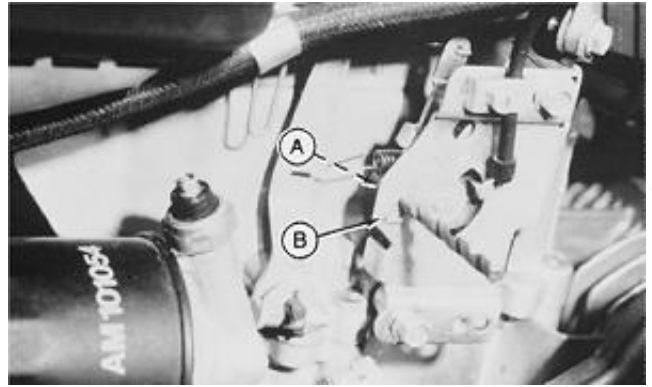

M53170 -UN-21AUG89

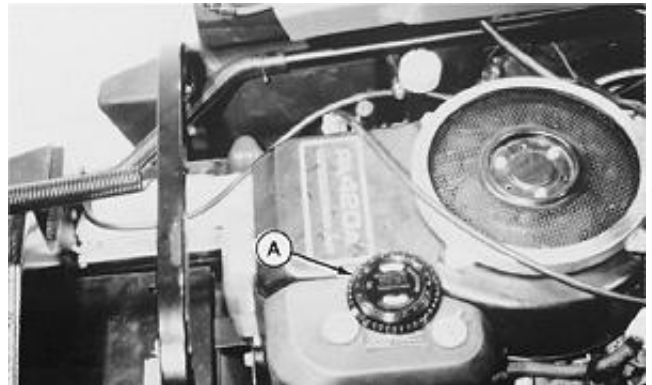

M53278 -UN-21AUG89

SLOW IDLE SPEED ADJUSTMENT—F510 (—100203) AND F525 (—100392)

Reason:

To set engine **slow idle** mixture and rpm.

Equipment:

- JTO5719 Photo Tachometer

Procedure:

1. Move key switch to **OFF** position.
2. Put transaxle/transmission in **neutral**.
3. Engage park brake.
4. Raise and lock seat platform.
5. Raise rear shroud.

IMPORTANT: Forcing the slow idle mixture screw tight will damage the needle and seat.

6. Put reflective tape on blower housing.
7. Turn slow idle mixture screw (A) (for PA540A-access screw through hole (B) in rear shroud) **clockwise until lightly seated, then turn counter-clockwise 1-1/8 turns.**
8. Start and run engine at **medium idle** for 5 minutes.
9. Move throttle lever to **slow idle** position.
10. Use a photo tachometer to check engine rpm at the blower housing screen.
11. Turn slow idle stop screw (C) on carburetor until **slow idle** speed is **1450 ±100 rpm.**
12. Turn slow idle mixture screw (A) **clockwise until engine speed drops, then counter-clockwise until engine speed increases and begins to drop again.**
13. Adjust slow idle mixture screw (A) for **highest engine speed between drops, then turn screw counter-clockwise an additional 1/4 turn.**
14. Turn slow idle stop screw (C) on carburetor to get **slow idle** speed of **1450 ±100 rpm.**

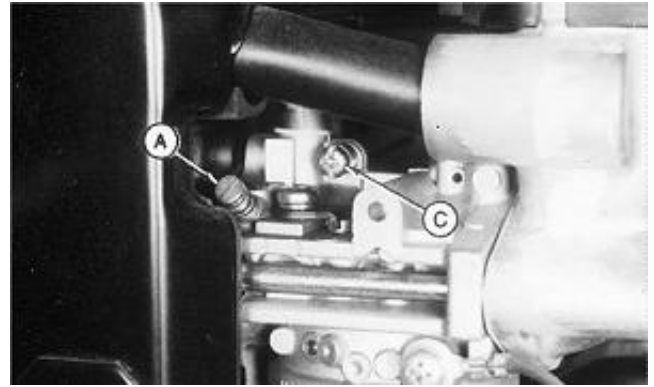

PA420A

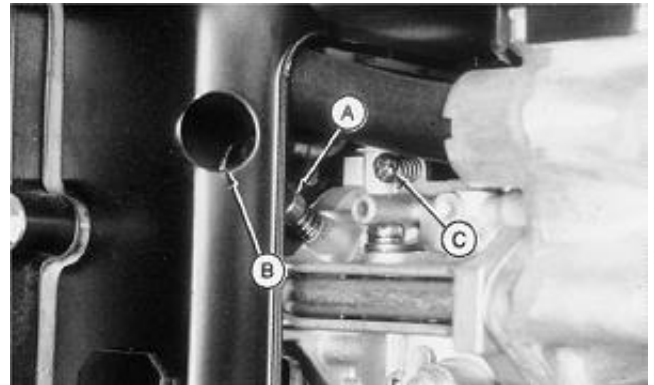

PA540A

M45938 -UN-11JUN91

M45939 -UN-11JUN91

SLOW IDLE SPEED ADJUSTMENT—F510 (100204—) AND F525 (100393—)

Reason:

To set engine slow idle mixture and rpm.

Equipment:

- JTO5719 Photo Tachometer

Procedure:

1. Move key switch to **OFF** position.
2. Put transaxle/transmission in **neutral**.
3. Engage park brake.
4. Raise and lock seat platform.
5. Raise rear shroud.

IMPORTANT: Forcing the slow idle mixture screw tight will damage the needle and seat.

6. Put reflective tape on blower housing.

MX,22015CL,30A -19-23OCT95

7. Turn slow idle mixture screw (A) (for PA540A-access screw through hole (B) in rear shroud) **clockwise until lightly seated, then turn counter-clockwise 1-3/8 turns for PA420A or 1-1/2 turns for PA540A.**

8. Start and run engine at **medium idle** for 5 minutes.

9. Move throttle lever to **slow idle** position.

10. Turn slow idle stop screw (C) on throttle control lever **counter-clockwise until it does not contact the throttle control plate (D).**

11. Use a photo tachometer to check engine rpm at the blower housing screen.

12. Turn slow idle stop screw (E) on carburetor until **slow idle** speed is **1450 ±100 rpm**

13. Turn slow idle mixture screw (A) **clockwise until engine speed drops, then counter-clockwise until engine speed increases and begins to drop again.**

14. Adjust slow idle mixture screw (A) for **highest engine speed between drops, then turn screw counter-clockwise an additional 1/4 turn for PA420A or 1/8 turn for PA540A.**

15. Turn slow idle stop screw (E) on carburetor to get idle speed of **1450 ±100 rpm.**

16. Turn slow idle stop screw (C) on throttle control lever to get idle speed of **1450 ±100 rpm.**

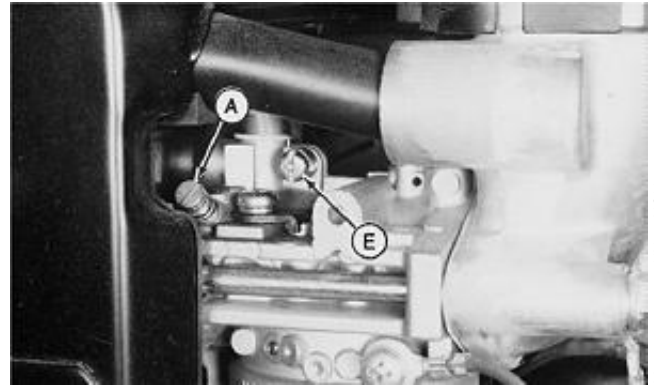

PA420A

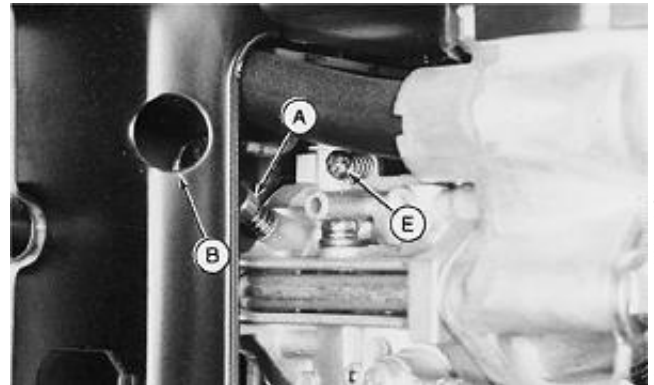

PA540A

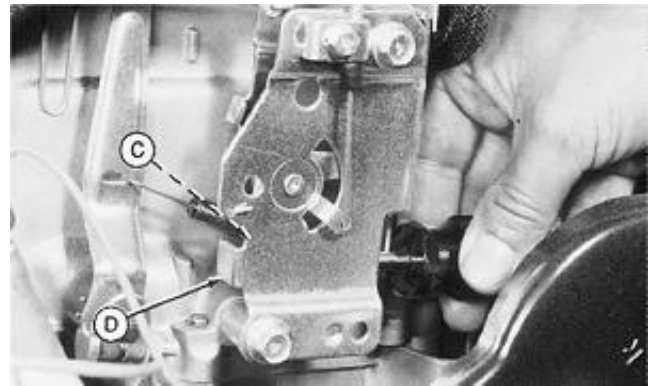

MX,22015CL,30B -19-23OCT95

M45797 -UN-12NOV90

M45798 -UN-12NOV90

M45940 -UN-11JUN91

CYLINDER COMPRESSION TEST

Reason:

To check pressure capacity of piston rings and cylinder bore for efficient engine operation.

Equipment:

- JDM-59 Compression Gauge

Connections:

1. Move key switch to **OFF** position.
2. Put transaxle/transmission in **neutral**.
3. Engage park brake.
4. Raise and lock seat platform.
5. Raise rear shroud.

IMPORTANT: Spark plug wire must be grounded or electronic ignition could be damaged.

6. Disconnect and ground spark plug wire.
7. Remove spark plug and install JDM-59 Compression Gauge (A).

Procedure:

1. Move the throttle lever to **fast idle** position.
2. Crank engine for a minimum of 5 revolutions and record compression reading. Compression should be a minimum of **483 kPa (71 psi)**.

Results:

- If compression is low, perform the Compression Leak Check.
- If compression is high, check automatic compression release mechanism.



M53280 -UN-21AUG89

MX,22015CL,31 -19-23OCT95

COMPRESSION LEAK CHECK

Reason:

To verify the source of the compression leak.

Equipment:

- JDM-59 Compression Gauge

Procedure:

1. Remove compression gauge.
2. Put clean engine oil on piston rings through spark plug hole.
3. Repeat cylinder compression test procedure.

Results:

- IF COMPRESSION PRESSURE INCREASES: check rings, piston and cylinder bore for broken rings, scoring, wear, or damage. Replace as necessary.
- IF COMPRESSION PRESSURE IS STILL LOW: check for leaking intake or exhaust valves, valve seal, or cylinder head gasket. Replace as necessary.



M53280 -UN-21AUG89

MX,22015CL,32 -19-23OCT95

VALVE CLEARANCE ADJUSTMENT

Reason:

To obtain the proper valve clearance that is critical for the valves to seat properly and for the automatic compression release to operate correctly.

Equipment:

- Feeler Gauge

Procedure:

IMPORTANT: Perform valve clearance measurement or adjustment when engine is cold. Proper valve clearance is essential for the compression release system to operate correctly.

1. Move key switch to **OFF** position.
2. Put transaxle/transmission in **neutral**.
3. Engage park brake.
4. Raise and lock seat platform.
5. Raise rear shroud.
6. Remove and ground spark plug lead. Remove spark plug.
7. Remove valve cover.
8. Turn crankshaft until piston, visible in spark plug hole (A), is at TDC (top dead center) of the compression stroke (both intake and exhaust valves will be closed).
9. Use a feeler gauge (B) to measure valve clearance.

Specifications:

- **Intake Valve Clearance (cold) .. 0.15 mm (0.006 in.)**
- **Exhaust Valve Clearance (cold) .. 0.15 mm (0.006 in.)**
- **Jam Nut Torque .. 20 N·m (180 lb-in.)**

Results:

- If valve clearance **DOES NOT** meet the specifications, loosen nut (C). Turn screw (D) to adjust valve clearance to specifications. Hold screw and tighten nut to proper torque. Repeat clearance check until specifications are met.

NOTE: *BEFORE* you install the spark plug and valve cover, perform the Automatic Compression Release Check.

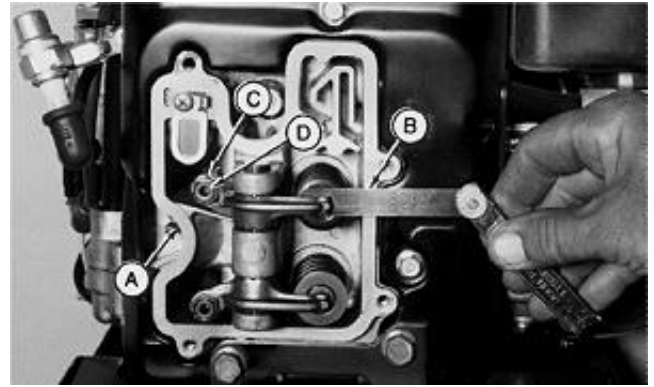

M45799 -UN-12NOV90

AUTOMATIC COMPRESSION RELEASE (ACR) CHECK

Reason:

To determine if the automatic compression release is opening the exhaust valve.

Equipment:

- Dial Indicator

Procedure:

1. Immediately after adjusting the valves, while valve cover and spark plug are removed, rotate crankshaft slowly clockwise to observe ACR operation.
2. The exhaust valve (A) **MUST OPEN (depress) briefly just after the intake valve closes.**
3. Use a dial indicator to measure exhaust valve ACR movement. Movement should be a minimum of **0.25 mm (0.01 in.)**.

Results:

- If the exhaust valve DOES NOT open or depress properly, the automatic compression release tab is faulty.

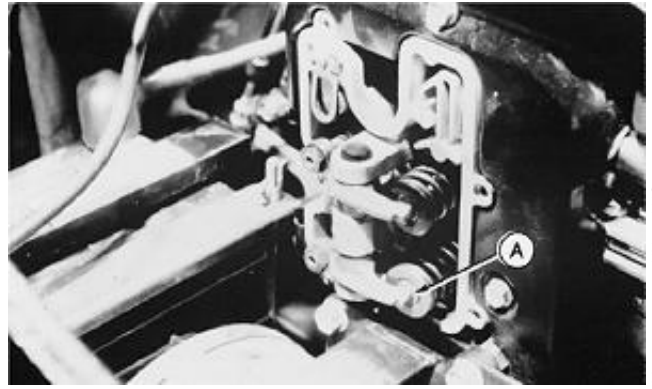

M53168 -UN-21AUG89

MX,22015CL,34 -19-23OCT95

CRANKCASE VACUUM TEST

Reason:

To measure the amount of crankcase vacuum, which ensures the crankcase is not pressurized. A pressurized crankcase will force oil leakage past the seals and gaskets and affect fuel pump operation.

Equipment:

- 8741-F66 Plug (A)
- JTO5703 Barb Fitting (B)
- JTO5699 Line (C)
- JTO5698 U-Tube Manometer (D)

Connections:

1. Move key switch to **OFF** position.
2. Put transaxle/transmission in **neutral**.
3. Engage park brake.
4. Raise and lock seat platform.
5. Raise rear shroud.
6. Remove dipstick.

MX,22015CL,35 -19-23OCT95

7. Put plug (A) in dipstick hole.
8. Finish making test connections from JTO5697 U-Tube Manometer Kit.
9. **Close manometer vent.**

Procedure:

IMPORTANT: Keep the vent side of manometer closed until the engine is running or fluid in manometer will be sucked into crankcase.

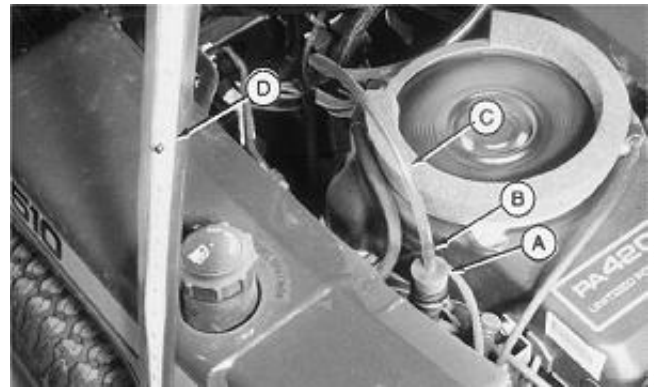

1. Start and run engine at **fast idle**.
2. Open manometer vent and record water movement inside Manometer. Crankcase vacuum should be a minimum of **25.4 cm (10 in.) water movement**.
3. Close manometer vent and stop engine.

Results:

If crankcase vacuum DOES NOT meet specifications, check the following:

- breather reed valve clearance and condition
- seals and gaskets for leakage
- fuel pump vacuum hose leakage
- rocker arm cover O-ring for leakage
- rings, piston, and cylinder bore for wear or damage

MX,22015CL,35A -19-23OCT95

OIL PRESSURE TEST

Reason:

To be sure engine has enough oil pressure to lubricate all internal components.

Equipment:

- JTO3338 90° Elbow Fitting (A)
- JTO3017 Test Hose (B)
- JTO3344 Gauge, 2000 kPa (300 psi) (C)

Connections:

1. Move key switch to **OFF** position.
2. Put transaxle/transmission in **neutral**.
3. Engage park brake.
4. Raise and lock seat platform.
5. Raise rear shroud.
6. Check engine oil level and “top-off” as necessary.
7. Disconnect oil pressure switch connector. Remove oil pressure switch.
8. Make test connections with elbow fitting (A), hose (B), and gauge (C).
9. Start and run engine at **medium idle** for 5 minutes to heat engine oil to normal operating temperature.

Procedure:

1. Run engine at **fast idle**.
2. Record oil pressure reading. Oil pressure should be a minimum of **240 kPa (35 psi)**.

Results:

If oil pressure **DOES NOT** meet the specifications, inspect or replace the following:

- oil pressure relief valve for damage
- oil pump worn or damaged
- suction screen plugged
- oil filter plugged
- oil passages plugged
(especially cylinder head drain back passage)



M45942 -UN-11JUN91

FUEL PUMP TEST

Reason:

To check condition of fuel pump and determine fuel pressure.

Equipment:

- JDG356 Pressure Gauge
- Graduated Container

Connections:

1. Move key switch to **OFF** position.
2. Put transaxle/transmission in **neutral**.
3. Engage park brake.
4. Start and run engine at **slow idle** for 1 minute to fill carburetor with fuel.
5. Stop the engine.
6. Raise and lock seat platform.
7. Raise rear shroud.

Continued on next page

MX,22015CL,37 -19-23OCT95

8. Disconnect and plug fuel pump outlet hose (A).
9. Connect JDG356 Pressure Gauge (B) hose to fuel pump spigot.

Procedure:

1. Start and run engine at **fast idle** for 15 seconds, then record pressure reading.
2. Stop engine.
3. Remove pressure gauge hose and connect fuel pump outlet hose (A).
4. Disconnect fuel pump outlet hose (C) from carburetor and put it in a graduated container.
5. Start and run engine at **fast idle** for 15 seconds, then stop the engine and record container measurement.

Specifications:

- **Minimum pressure .. 6.12 kPa (0.9 psi)**
- **Minimum flow:**
 - PA420A .. 80 mL/15 seconds (2.7 oz/15 seconds)
 - PA540A .. 90 mL/15 seconds (3 oz/15 seconds)
- **Engine speed .. FAST IDLE**

Results:

- If fuel pump pressure or flow DOES NOT meet the specifications, check the following:
- fuel lines, filter, shut-off valve, and fuel tank cap for restrictions
 - check crankcase vacuum
 - repair or replace fuel pump

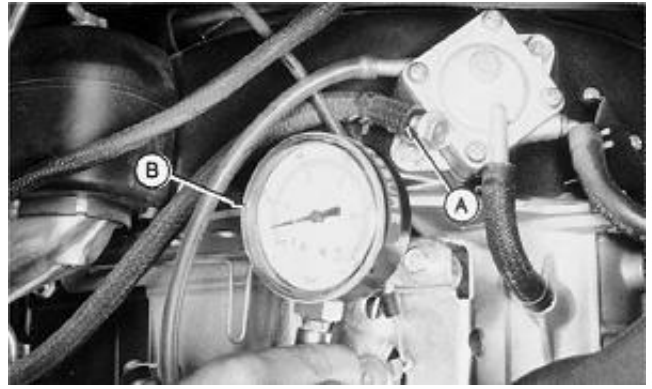

M45943 -UN-11JUN91



M45944 -UN-11JUN91

MX,22015CL,37A -19-23OCT95

FUEL/AIR OPERATION, TESTS, AND ADJUSTMENTS

Section 230

230

Contents

Page

Group 05—Component Location

Component Location Information	230-05-1
Fuel and Air System Components	230-05-2

Group 10—Theory of Operation

Theory Information	230-10-1
Fuel System Operation	230-10-2
Float & Main Jet Circuit Operation	230-10-4
Slow and Fast Idle Circuit Operation	230-10-6
Choke Circuit Operation	230-10-8
Fuel Pump Operation	230-10-10
Governor Operation	230-10-12
Air Intake System	230-10-14

Group 15—Diagnosis, Tests, and Adjustments

Fuel/Air Diagnostic Information	230-15-1
-------------------------------------------	----------

COMPONENT LOCATION INFORMATION

This group contains component location drawing for the machine fuel/air system components.

Use the drawing when diagnosing a fuel/air problem and to help locate the components to be tested.

MX,23005CL,1 -19-23OCT95

230
05
1

FUEL AND AIR SYSTEM COMPONENTS

A—Fuel Tank Cap	H—Fuel Pump Vacuum Hose	O—Paper Element	U—Air Cleaner Cover
B—Fuel Tank Hose	I—Control Plate	P—Foam Element	V—Blower Housing
C—Screen	K—Throttle Lever	Q—Fuel Shut-Off Solenoid ¹	W—Flywheel Fan
D—Fuel Filter	L—Fuel Pump Outlet Hose	R—Air Cleaner Base	X—Fuel Shutoff Valve
E—Fuel Pump Inlet Hose	M—Throttle Linkage	S—Carburetor	Y—Fuel Tank Vent Hose
F—Fuel Pump	L—Choke Linkage	T—Air Cleaner Housing	Z—Fuel Tank
G—Throttle Cable	N—Governor Arm		

¹ See Electrical System Tests and Adjustments.

MX,23005CL,2 -19-23OCT95

230
05
2

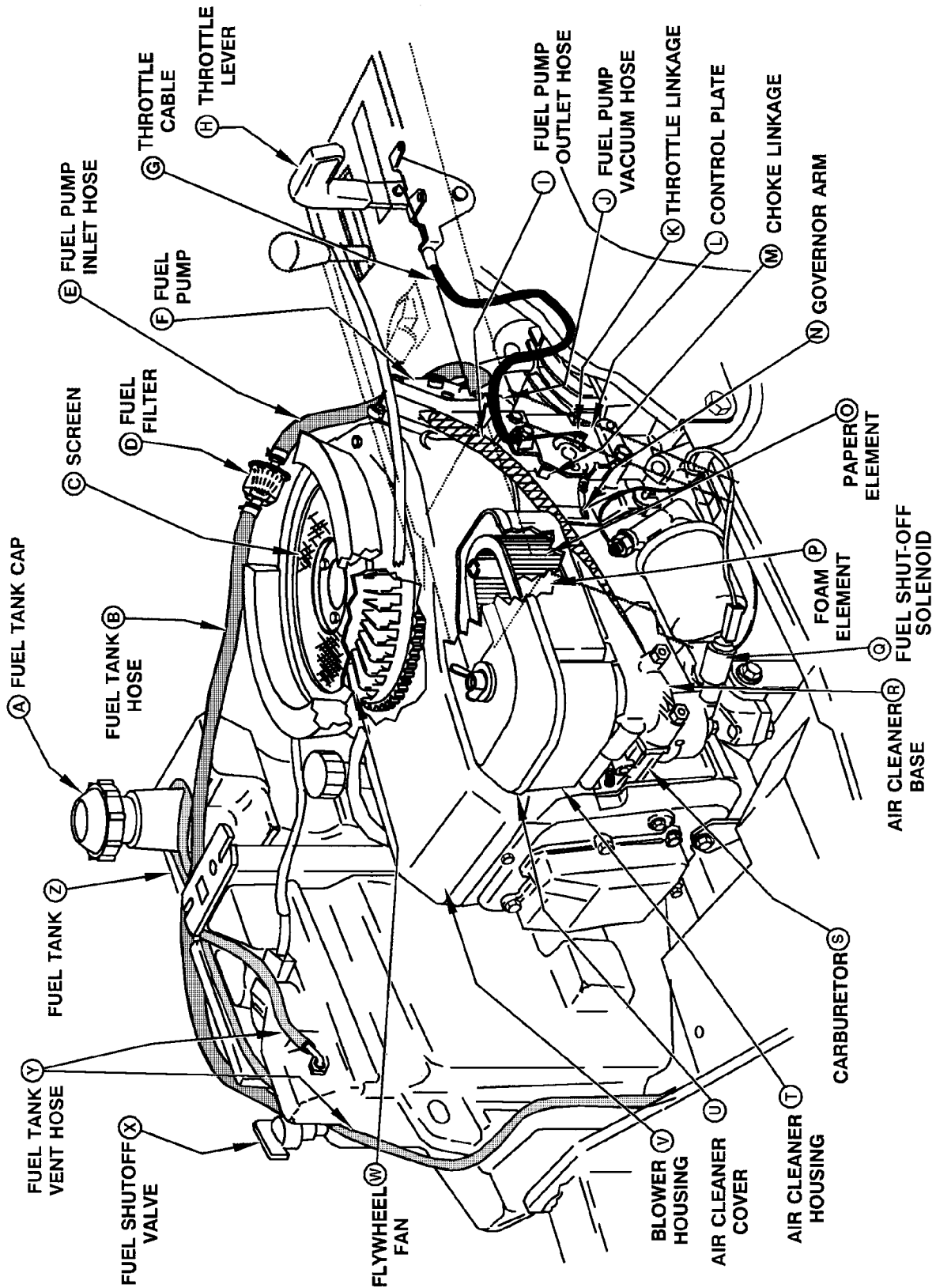

FUEL AND AIR SYSTEM COMPONENTS

230-05-3

-JUN-05/JUL-95

M83011

MX,23005CL,3 -19-23OCT95

230
05
4

THEORY OF OPERATION INFORMATION

This group divides the fuel/air system into individual components or sub-systems by function. The story contains information on function, component or sub-system identification and theory of operation.

The following systems or components are covered:

- Fuel System Operation
- Carburetor Float and Main Jet Circuit Operation
- Slow and Fast Idle Circuit Operation
- Choke Circuit Operation
- Fuel Pump Operation
- Governor Operation
- Air Intake System Operation

MX,23010CL,1 -19-23OCT95

230
10
1

FUEL SYSTEM OPERATION

A—Fuel Tank Cap
B—Fuel Tank
C—Fuel Tank Hose

D—Fuel Filter
E—Fuel Pump Inlet Hose
F—Fuel Pump

G—Fuel Pump Outlet Hose
H—Fuel Shut-Off Solenoid
I—Carburetor

J—Fuel Tank Vent Hose
K—Fuel Shutoff Valve

Function:

Supply pressure fuel to the carburetor for engine operation.

Major Components:

- Carburetor
- Fuel Shut-off Valve
- Fuel Filter
- Fuel Tank
- Fuel Tank Cap
- Fuel Pump
- Fuel Lines
- Fuel Shut-Off Solenoid

Theory of Operation:

Fuel is supplied to the carburetor (I) by a pressurized fuel system. The fuel tank (B) is vented through a vent hose (J) located along the side and top of the fuel tank. The fuel tank cap (A) is not vented. The

fuel pump (F) draws fuel from the fuel tank through the fuel shut-off valve (J), and fuel filter (D) and fuel pump inlet hose (E). The fuel filter uses a paper element to remove debris from the fuel and is clear to facilitate service. Pressure fuel in the outlet hose (G) from the fuel pump flows to the carburetor inlet. Fuel pressure is maintained at the carburetor inlet needle until the float allows more fuel in the bowl. The fuel shut-off solenoid (K) is actuated (retracted) electrically as soon as the key switch is moved to the "RUN" or "START" position and closes whenever the key switch is turned "OFF". This minimizes the occasional backfire that can occur when the engine is turned off. It closes off the main jet circuit to stop fuel from flowing into the engine during the time that the engine comes to a stop. This does not allow a combustible fuel/air mixture to flow into the hot muffler.

MX,23010CL,2 -19-23OCT95

230
10
2

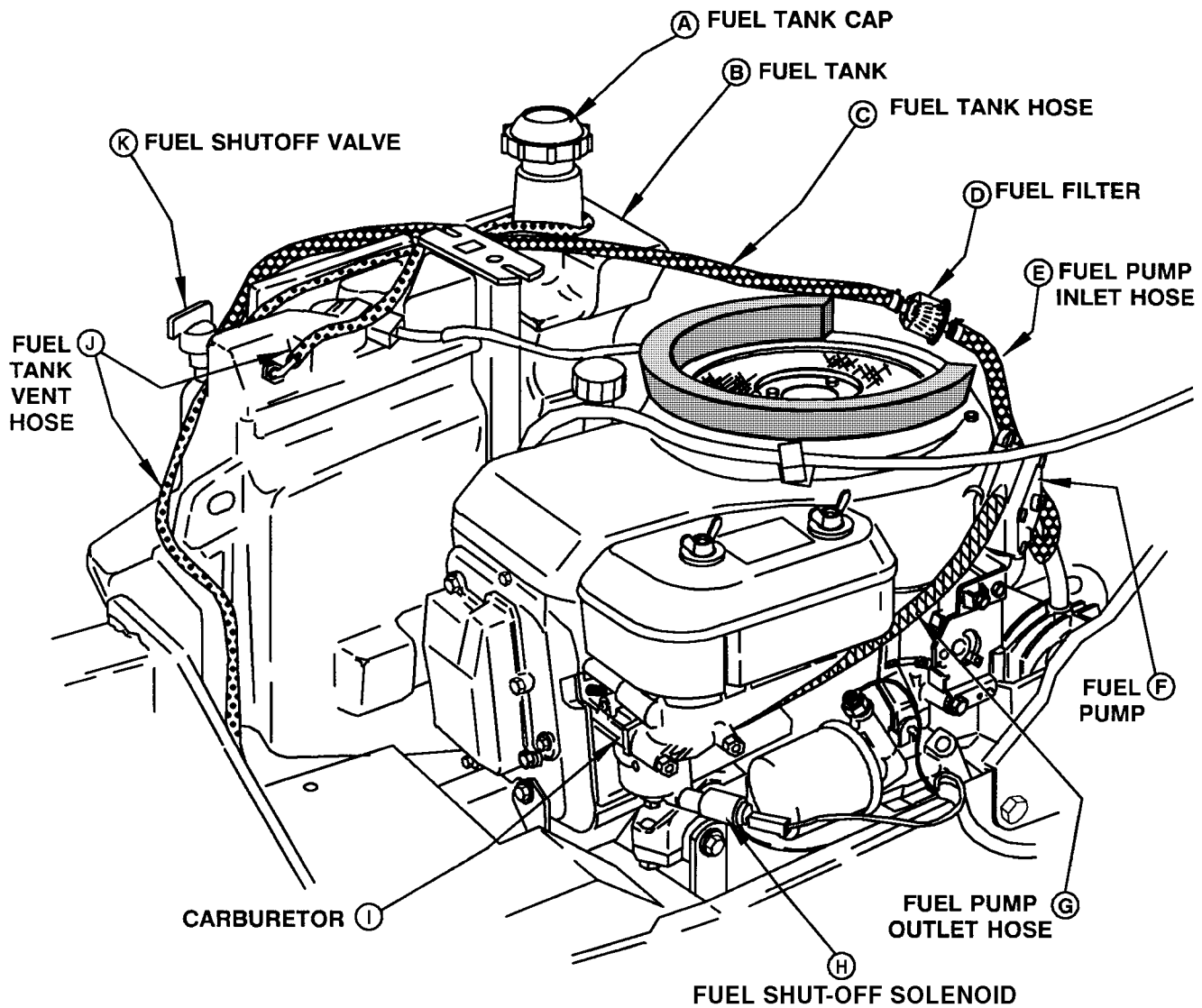

FUEL SYSTEM OPERATION

-JUN-05JUL95

M83012

MX,23010CL,3 -19-23OCT95

FLOAT AND MAIN JET CIRCUIT OPERATION

A—Choke Valve	G—Venturi	M—Fuel Shut-Off Solenoid
B—Main Air Jet	H—Main Nozzle	N—Float Bowl
C—Throttle Valve	I—Needle Seat	O—Float
D—Pressurized Fuel	J—Inlet Needle	P—Main Air Jet Passage
E—Air	K—Bleed Holes	Q—Pilot Jet
F—Fuel/Air Mixture	L—Main Jet	R—Float Bowl Vent Hole Only
		F510 (—100203) and F525 (—100392) Sleeve and Tube
		F510 (100204—) and F525 (100393—)

Function:

Float - control the amount and level of the fuel in the float bowl.

Main jet - supply the correct fuel/air mixture during the time that the engine is being run under partial or full load.

Major Components:

- Inlet Needle
- Needle Seat
- Float
- Float Bowl
- Main Jet (Location varies with model)
- Main Nozzle
- Bleed Holes
- Main Air Jet
- Shut-Off Solenoid (Location varies with model)

Theory of Operation:

Pressurized fuel (D) flows from the tank to the fuel inlet, past the inlet needle (J) and needle seat (I) into the float bowl (N) of the carburetor. The inlet needle is connected to the float (O). As the fuel level and the float rise, the inlet needle rises and starts to restrict the flow of fuel into the float bowl. As the engine runs and draws fuel through the main (L) and pilot (Q) jets, the level in the float bowl lowers which also pulls the inlet needle off its seat. This allows an increase in the flow of fuel past the inlet needle and seat and the float again rises. Therefore, under all operating conditions, the fuel in the float bowl stays at the constant level that is needed for proper operation.

The main jet circuit on this carburetor is a fixed-jet design. It cannot be adjusted, but different sized jets

can be installed to give proper operation at various altitudes. The main jet (L) meters the amount of pressurized fuel (D) that will be drawn into the engine. The main air jet (B) meters the amount of air (E) that will be mixed with the fuel before being drawn into the engine. The main jet circuit starts to control the fuel supply as a load is applied to the engine at any throttle setting. When a load is applied, the governor starts to open the throttle valve (C). As the throttle valve opens, air flow past the venturi (G) increases and a low pressure is created. For F510 (—100203) and F525 (—100392), the float bowl vent (R) is a hole located on top of the carburetor. For F510 (100204-) and F525 (100393-), the float bowl vent (R) located on the top of the carburetor uses a pressed in sleeve and plastic tube to help prevent debris from entering the float bowl. The air from the float bowl vent that is above the fuel in the float bowl is at atmospheric pressure so the pressure difference forces fuel through the main jet up the main nozzle (H). The bleed holes (K) in the main nozzle mix a small amount of air with the fuel to help atomize the fuel. At the venturi, this fuel-rich mixture is mixed with the intake air to give the correct fuel/air (F) mixture for engine operation. A small amount of fuel/air mixture is also supplied by the idle circuits during load operation. The main jet circuit is capable of supplying the correct fuel/air mixture for all load conditions.

The fuel shut-off solenoid (M) is in the carburetor to minimize the occasional backfire that can occur when the engine is turned off. It closes off the main jet circuit to stop fuel from flowing into the engine during the time that the engine comes to a stop. This does not allow a combustible fuel/air mixture to flow into the hot muffler.

230
10
5

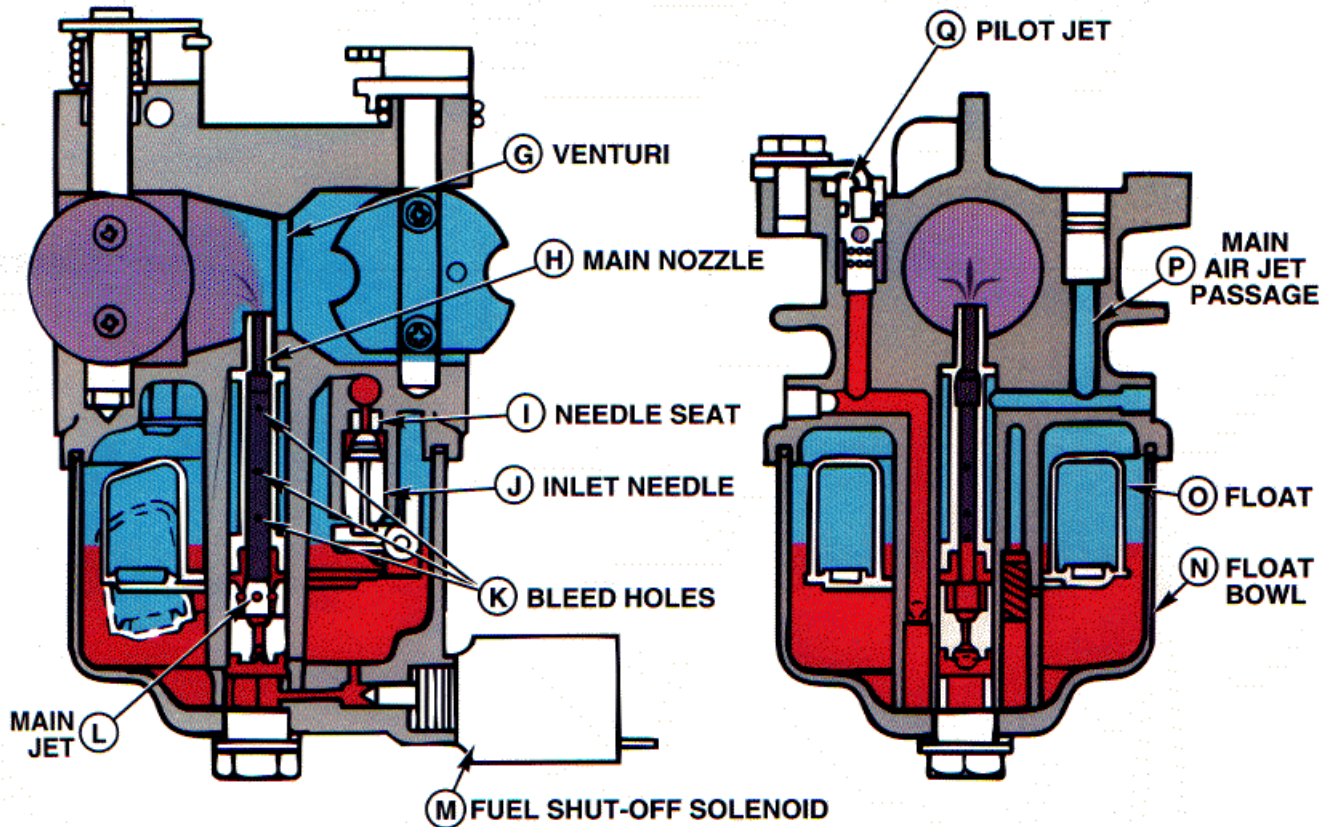
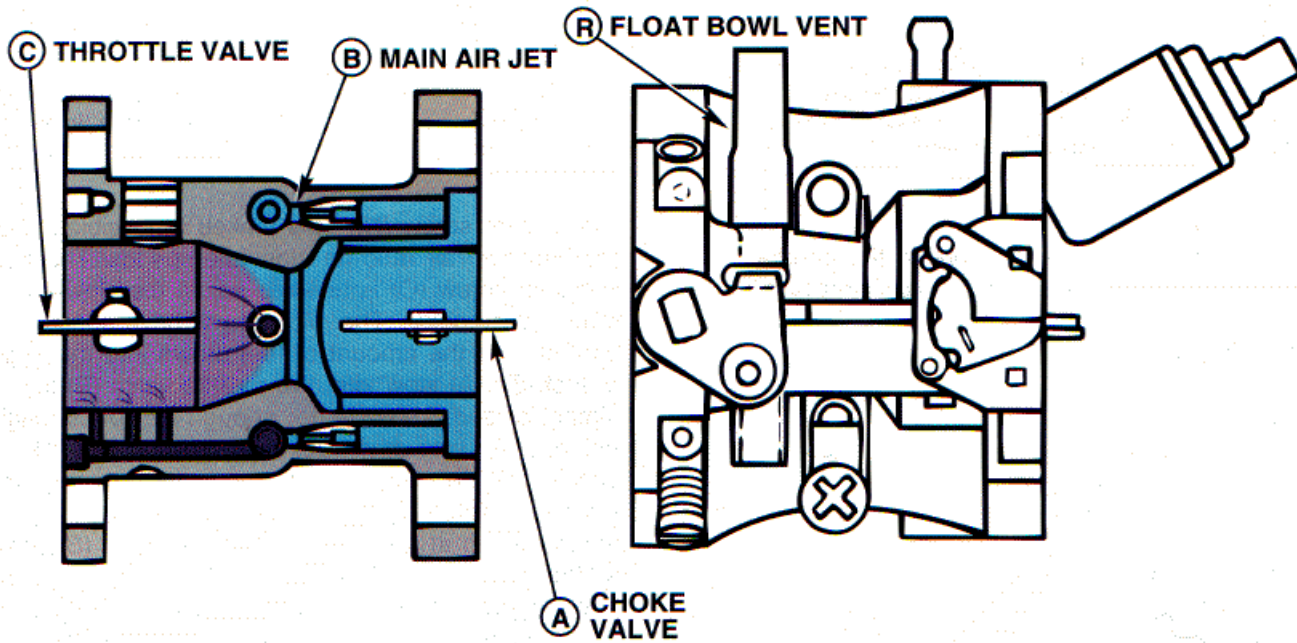

FLOAT & MAIN JET OPERATION

MXC45668

-19-
MXC45668

MX,23010CL,5 -19-04MAY92

SLOW AND FAST IDLE CIRCUIT OPERATION

A—Choke Valve	E—Transition Passages	I—Fuel/Air Mixture	M—Pilot Jet
B—Throttle Valve (Slow Idle)	F—Pilot Air Jet	J—Venturi	N—Slow Idle Mixture Screw
C—Throttle Valve (Fast Idle)	G—Pressurized Fuel	K—Main Jet	O—Slow Idle Stop Screw
D—Slow Idle Mixture Screw Passage	H—Air	L—Pilot Jet Passage	

Function:

Supply the correct fuel/air mixture to the engine during no load conditions at both slow and fast idle.

Major Components:

- Pilot Jet
- Pilot Air Jet
- Slow Idle Passage
- Slow Idle Mixture Screw
- Transition Passages

Theory of Operation:

The slow and fast idle circuits of this engine are of a fixed-jet design. The pilot jet (M) is not adjustable but can be changed for various conditions. There is also a pilot air jet (F) that meters a small amount of air (H) that is mixed with the fuel (G) at the pilot jet. The amount of this fuel/air mixture (I) that is drawn into the engine at slow idle can be adjusted by the slow

idle mixture screw (N). This makes it possible to get the best fuel/air ratio for slow idle speeds. The slow idle stop screw (O) is used to adjust the slow-idle rpm of the engine. The pilot jet will have some control over the amount of fuel drawn into the engine at fast idle. At slow idle, the throttle valve (B) is almost closed. There is not enough air flow through the venturi (J) to draw fuel from the main jet (K) circuit. The only fuel/air drawn in will be through the slow idle mixture screw passage (D). When the engine is run at fast idle, the throttle valve (B) opens a little more to fast idle position (C). There is still not enough air flow to draw fuel through the main jet circuit, but more fuel/air mixture is required. This additional fuel/air mixture is supplied by transition passages (E). These passages begin supplying the fuel/air mixture as the edge of the throttle valve pass them. They also help supply fuel/air during the transition from a no-load to a load condition.

MX,23010CL,6 -19-23OCT95

230
10
7

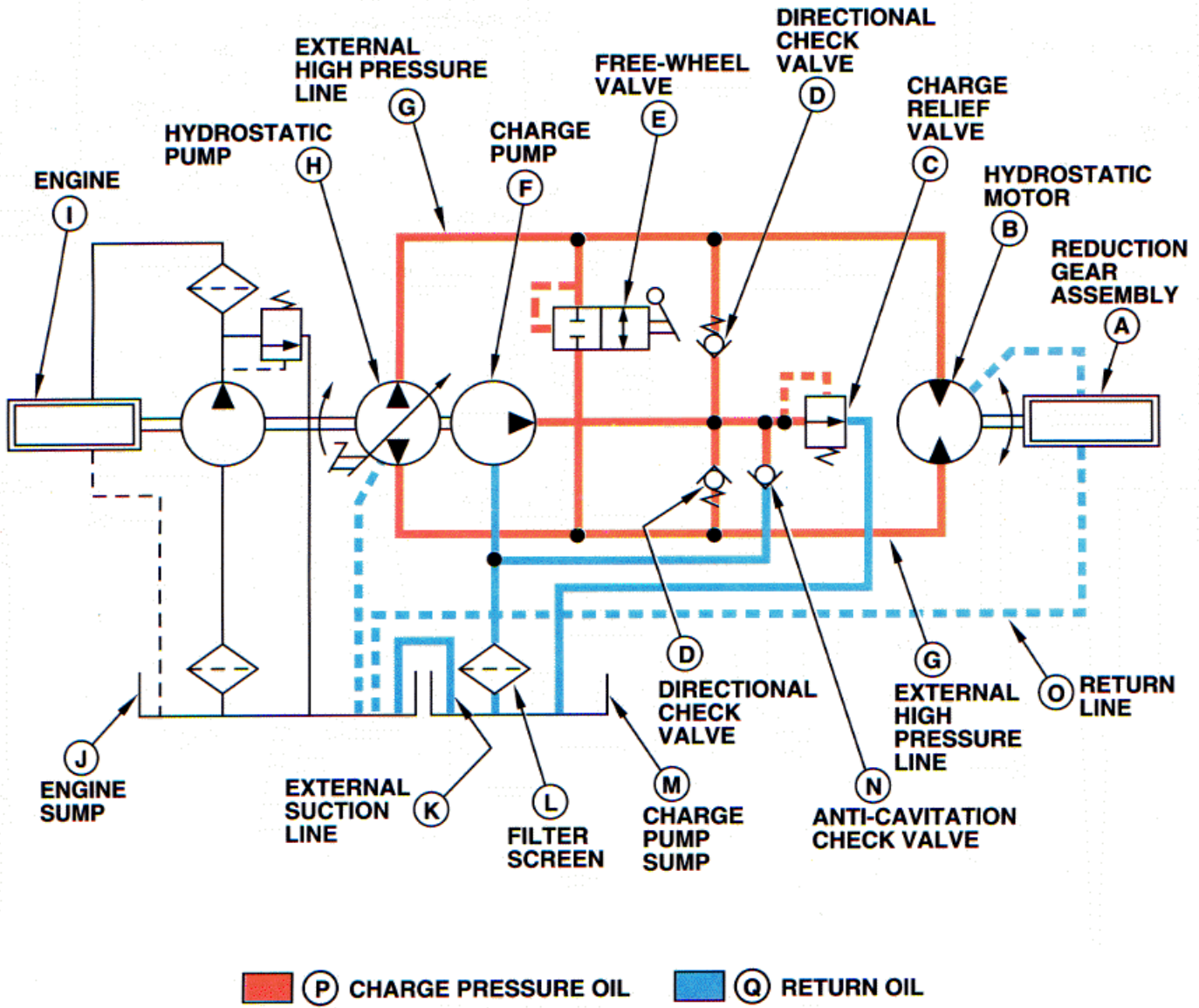

MXC44984

HYDROSTATIC CIRCUIT OPERATION - NEUTRAL

-19-
MXC45669

CHOKE CIRCUIT OPERATION

A—Choke Valve
B—Throttle Valve
C—Slow Idle Mixture Screw
Passage

D—Transition Passages
E—Pressurized Fuel
F—Air

G—Fuel/Air Mixture
H—Main Nozzle

I—Main Jet
J—Pilot Jet

Function:

Supply a rich fuel/air mixture to help when starting a cold engine.

Major Components:

- Choke Valve
- Main Jet (Location varies with model)
- Pilot Jet

Theory of Operation:

When the engine and/or air is cold, a fuel-rich, fuel/air mixture (G) is needed to start the engine. With the choke valve (A) closed and the throttle valve (B) fully open, very little air (F) can be drawn into the engine. During the intake stroke, the engine still wants as much air so a high vacuum is created in the carburetor. This vacuum draws a fuel/air mixture in through both pilot jet (J) and main jet (I) circuits. Fuel will be drawn in through the slow idle mixture screw passage (C), transition passages (D), and main nozzle (H). Since there is little air, the mixture is the rich mixture needed for starting.

MX,23010CL,8 -19-23OCT95

230
10
8

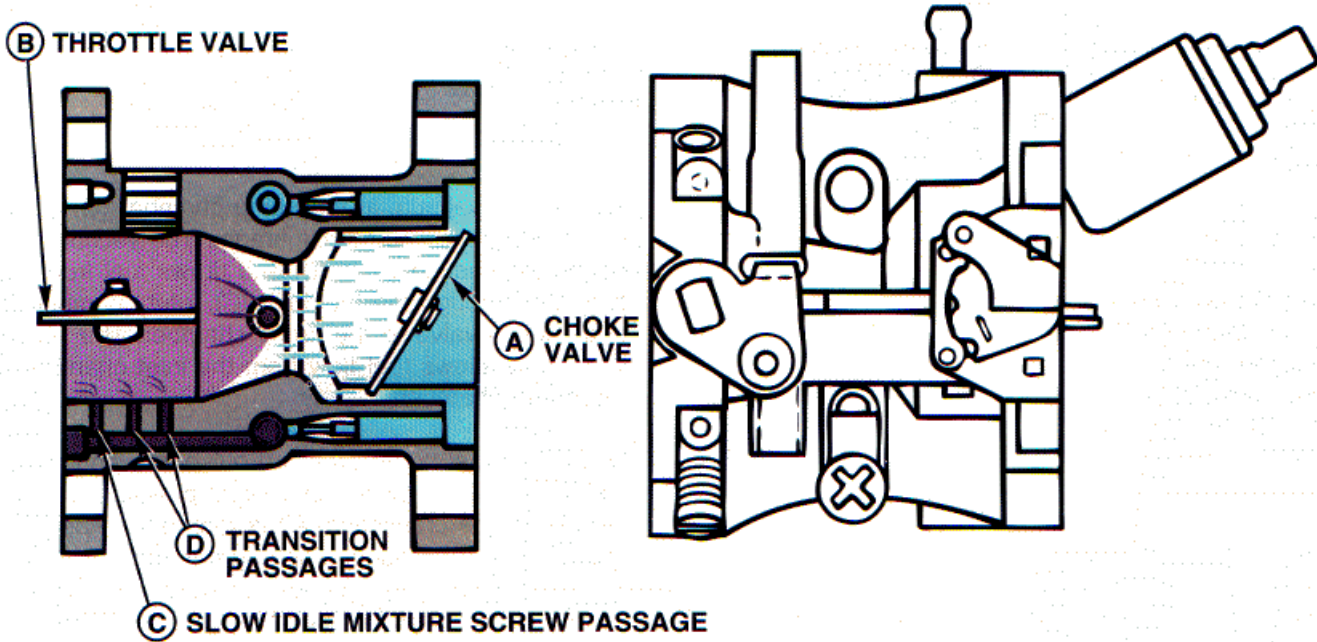

E FUEL **F** AIR **G** FUEL/AIR MIXTURE

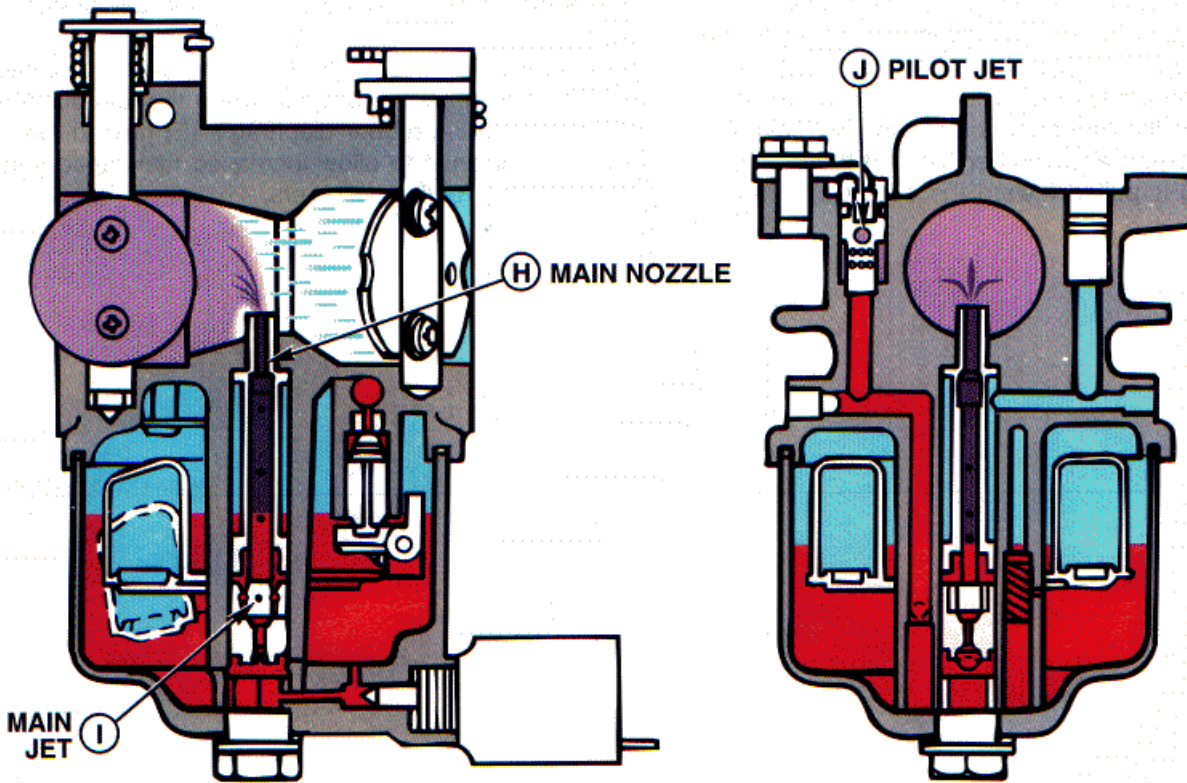

CHOKE OPERATION

MXC45670

MXC45670 -19-

MX,23010CL,9 -19-04MAY92

FUEL PUMP OPERATION

A—Crankcase Inlet
 B—Suction Valve
 C—Fuel Inlet
 D—Inlet Chamber
 E—Rubber Diaphragm

F—Outlet Chamber
 G—Pump Chamber
 H—Pressure Valve
 I—Base
 J—Body

K—Fuel Outlet
 L—Cover
 M—Vent
 N—Air Chamber

O—Pump Diaphragm
 P—Pressure Fuel
 Q—Suction Fuel
 R—Air

Function:

To supply pressure fuel to the carburetor.

Major Components:

- Pump Diaphragm
- Suction Valve
- Pressure Valve
- Rubber Diaphragm
- Inlet Chamber
- Outlet Chamber

Theory of Operation:

The fuel pump is a pressure/vacuum operated diaphragm pump. The pump operates using the changes in vacuum that occur in the crankcase during engine operation. Fuel pump pressure is about 6 kPa (1 psi).

During the fuel pump vacuum pulse, the engine piston moves upward and a vacuum is created in the crankcase due to the operation of the breather system. A hose connected to the crankcase transfers this vacuum to the fuel pump crankcase inlet (A). Air is drawn out of the air chamber (N) and the pump diaphragm (O) is pulled toward the cover (L). This

produces a vacuum in the pump chamber (G) on the other side of the pump diaphragm. The vacuum opens the suction valve (B) and draws fuel from the fuel filter through the fuel inlet (C), inlet chamber (D), and suction valve to the pump chamber. The suction valve only allows fuel flow from the inlet chamber to the pump chamber.

During the fuel pump pressure pulse, the engine piston moves downward and slight pressure is created in the crankcase. Air is forced into the air chamber and the pump diaphragm is pushed away from the cover. This produces pressure in the pump chamber full of suction fuel. The pressure closes the suction valve, opens the pressure valve (H) and forces fuel into the outlet chamber (F). The pressure valve only allows fuel flow from the pump chamber to the outlet chamber. Fuel from the outlet chamber flows through the fuel outlet (K) to the carburetor.

The vent (M) in the cover allows the pump diaphragm to return to a neutral position when the fuel pump is not operating. A rubber diaphragm (E) next to the base (I) expands to allow increased fuel capacity in the inlet and outlet chambers.

MX,23010CL,10 -19-23OCT95

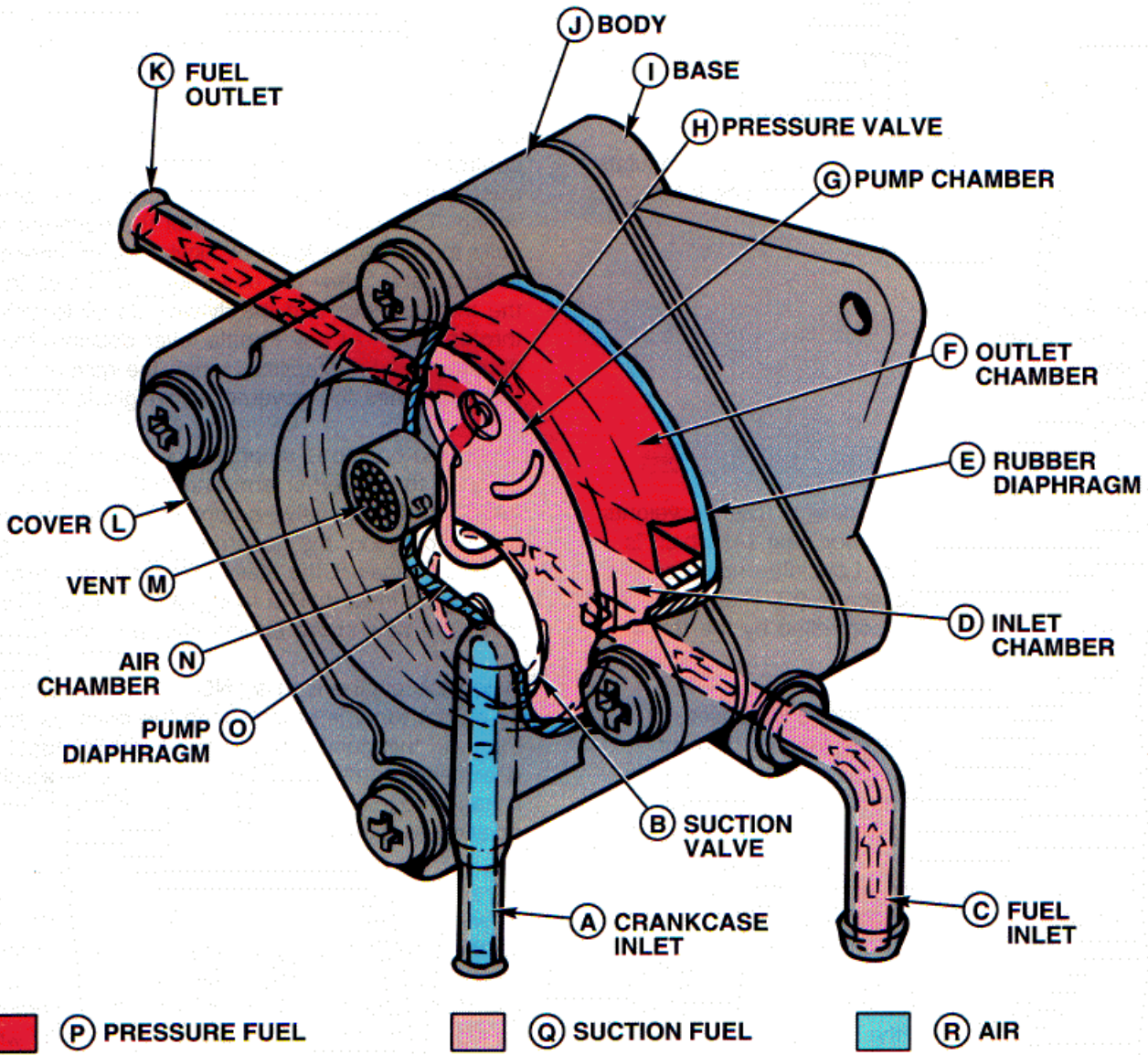

230
10
11

FUEL PUMP OPERATION

MXC45514

MX.23010CL.11 -19-23OCT95

MXC45514 -19-

GOVERNOR OPERATION

A—Governor Gear
B—Fly-Weights
C—Control Plate

D—Sleeve
E—Governor Lever
F—Governor Spring

G—Throttle Control Lever
H—Throttle Link
I—Governor Shaft

J—Carburetor Throttle Lever
K—Low Idle Stop Screw

Function:

Limit the maximum speed of the engine and regulate throttle valve position to match the engine load requirements.

Major Components:

- Fly-Weights
- Governor Lever
- Sleeve
- Control Panel
- Spring

Theory of Operation:

The governor is of fly-weight design. The fly-weights (B) are attached to the governor gear (A) which is driven by the oil pump gear. Low idle engine speed is controlled by low idle stop screw (K). High idle and maximum engine speed is controlled by the throttle control plate.

When the engine starts and speed increases, centrifugal force causes the fly-weights to pivot outward. The fly-weights push against sleeve (D) which pushes against governor shaft (I) causing it to rotate. Governor lever (E), which is clamped to the governor shaft, also begins to rotate in a counter-clockwise direction (when viewed from the right side of the engine). Connected to the governor lever is the throttle link (H) and the governor spring (F). The throttle link is connected to the carburetor throttle lever (J) which controls the throttle valve inside the carburetor. As the governor lever rotates counter-clockwise, the throttle valve starts to partially close to reduce engine speed. A governor spring is

connected to the throttle control lever (G) on the control plate (C). Moving the throttle lever to fast idle, rotates the control lever which pulls on the governor spring. The increased tension of the governor spring pulls the governor lever clockwise which opens the throttle valve. Now the governor spring tries to open the throttle valve and the fly-weights try to close the throttle valve. At any throttle lever position, the engine speed is stabilized when the governor spring force matches the governor fly-weight force.

When the engine is stopped, the governor spring pulls on the governor arm and throttle control link to open the throttle valve completely. Since the engine is not operating, the governor lever and shaft rotate and push against the sleeve. The sleeve pushes the fly-weights inward. The fly-weights and the throttle valve are now in the engine start position.

When the engine is in a "NO LOAD" condition, the fly-weight force is greater than the governor spring force. In this condition, the fly-weight linkage determines throttle valve position. The fly-weight linkage moves the throttle valve to a partially closed position to reduce engine speed.

When the engine is in a "LOAD" condition, the fly-weight force decreases as engine rpm decreases, so the governor spring force is greater than the fly-weight force. Now the governor spring force determines throttle valve position. The governor spring moves the throttle valve open slightly which increases engine speed to match the load.

MX,23010CL,12 -19-23OCT95

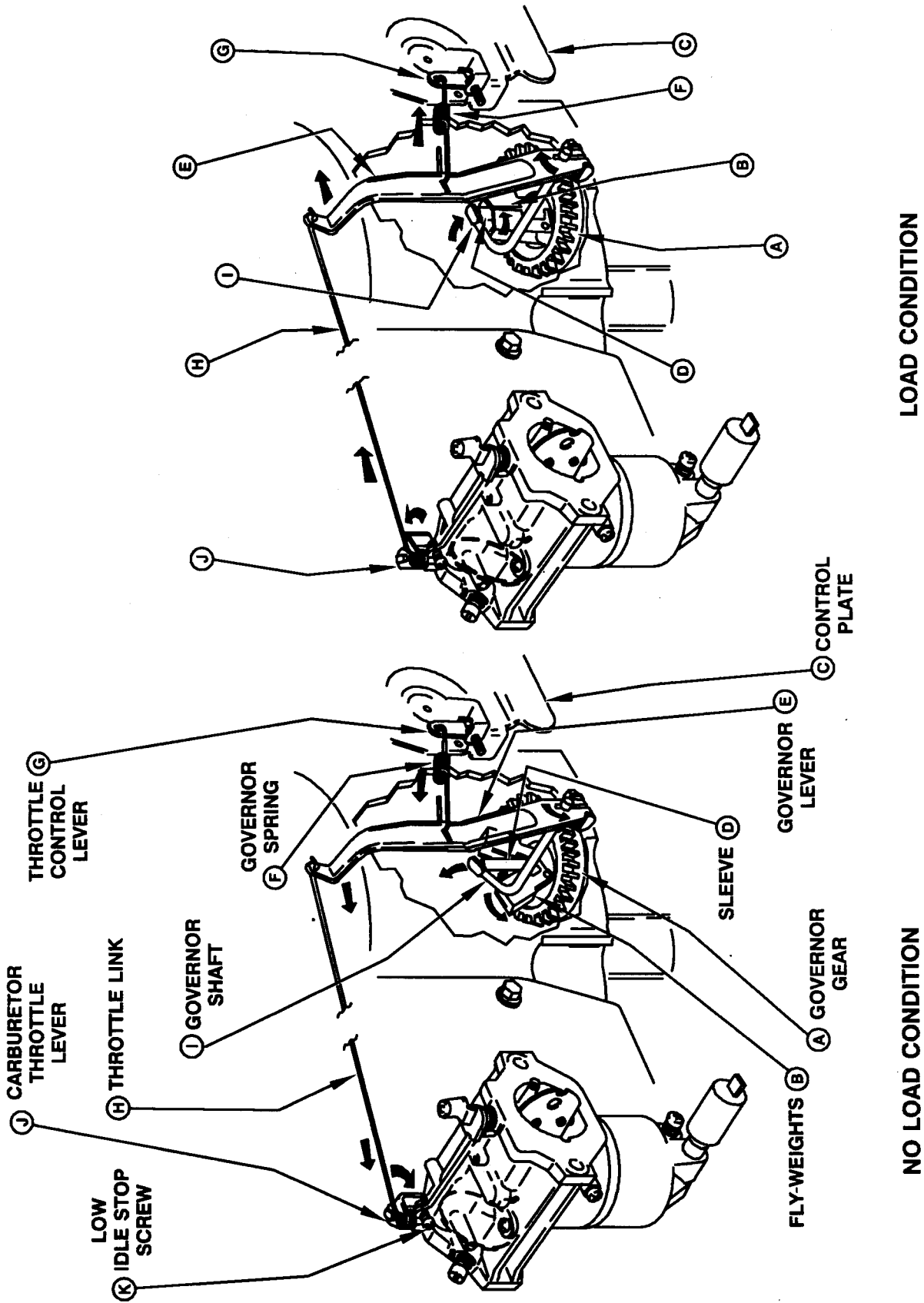

GOVERNOR OPERATION

LOAD CONDITION

NO LOAD CONDITION

M45893

M45893 -19-20DEC90

MX.23010CL.13 -19-04MAY92

AIR INTAKE SYSTEM

A—Intake Screen
B—Air Cleaner Housing
C—Paper Element

D—Foam Element
E—Air Cleaner Base

F—Housing Expulsion Slot
G—Carburetor

H—Blower Housing
I—Flywheel Fan

Function:

To provide filtered air for carburetion.

Major Components:

- Intake Screen
- Flywheel Fan
- Blower Housing
- Air Cleaner Housing
- Paper Element
- Foam Element

Theory of Operation:

A two stage filtration system, consisting of a foam and paper element, is used to filter carburetor inlet air. The carburetor (G) uses cooling air flow provided by a fan (I) that is part of the flywheel. During operation, the flywheel fan draws air in through the intake screen (A). The intake screen rotates and cuts

debris into small pieces to help prevent plugging the intake system. The blower housing (H) directs air from the fan to the air cleaner housing (B) and the engine cooling fins. The air cleaner housing design forces debris to the outside of the housing and then out through an expulsion slot (F) in the housing. The air is filtered by a foam element (D) and a paper element (C) before entering the carburetor.

Since the same air flow is used for both carburetion and cooling, it is important to keep the air intake clean. Also the engine covers should not be removed or altered. Debris build-up in the intake screen or cooling fins will affect the volume of air to the carburetor. Debris plugging the cooling fins will result in engine overheating. If the cooling air cannot flow over the cooling fins, it will be forced into the carburetor resulting in a lean fuel condition.

MX,23010CL,14 -19-23OCT95

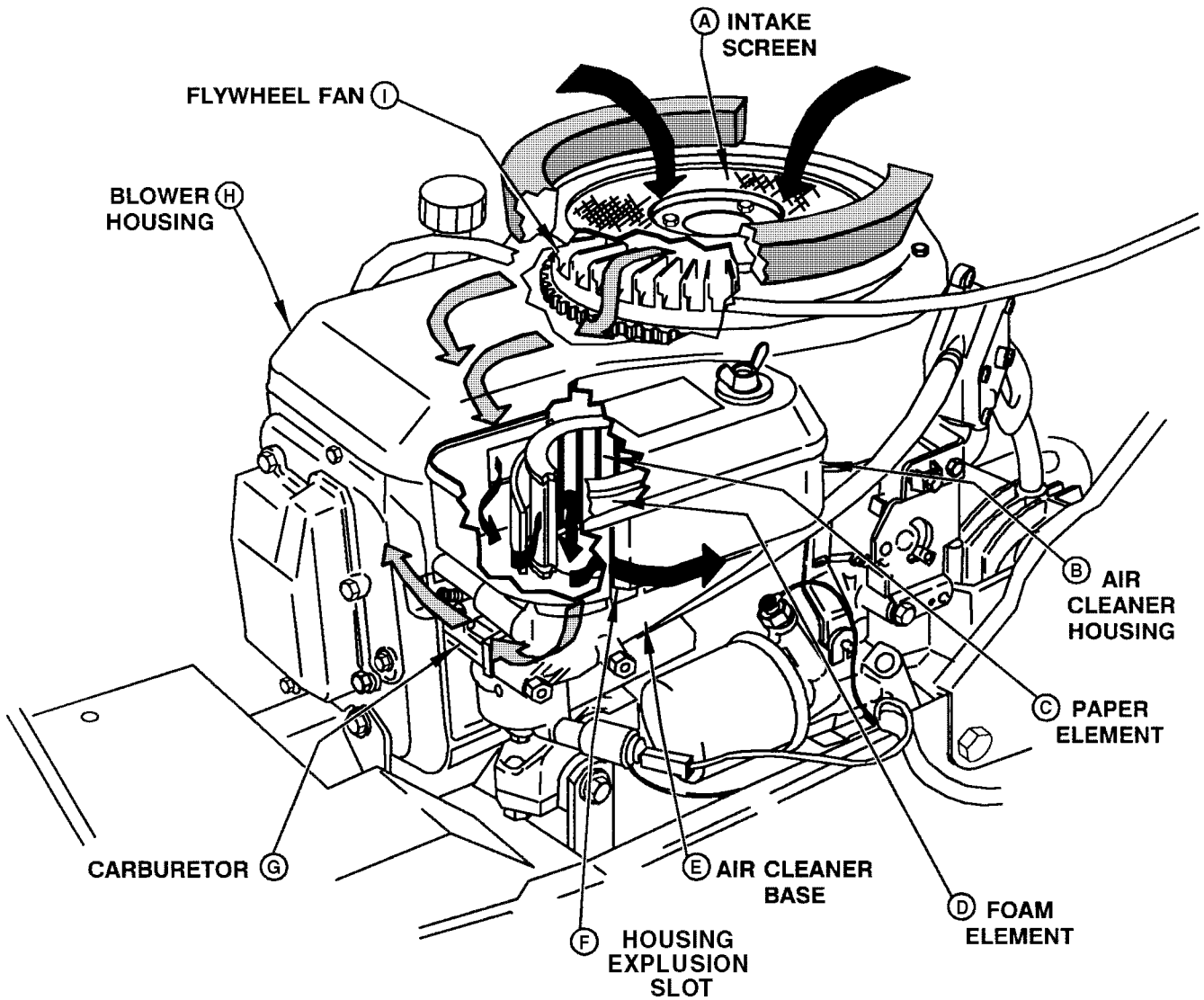

AIR INTAKE SYSTEM

M83013
-UN-11JUL95

MX,23010CL,15 -19-23OCT95

230
10
16

FUEL/AIR DIAGNOSTIC INFORMATION

FOR THIS PRODUCT, ALL DIAGNOSIS, TESTS & ADJUSTMENTS FOR THE FUEL/AIR SYSTEM ARE TAKEN CARE OF IN SECTION 220 GROUP 15. THIS IS DONE SINCE MANY ENGINE COMPLAINTS CAN BE CAUSED BY THE FUEL/AIR SYSTEM AND DIAGNOSING THEM SEPARATELY IS DIFFICULT.

MX,23015CL,1 -19-04MAY92

230
15
1

230
15
2

Section 240

ELECTRICAL SYSTEM OPERATION, TESTS, AND ADJUSTMENTS

Contents

	Page		Page
Group 05 —Component Location		Magneto And Ground Circuit Test Points	
Component Location Information	240-05-1	F510 (—011957) and F525	
Electrical System Components	240-05-2	(—012519)	240-15-14
Group 10—Theory of Operation		F510 (—011957) and F525	
Electrical Theory of Operation Information .	240-10-1	(—012519)	240-15-16
Cranking System Operation		F510 (011958—) and F525	
F510 (—011957) and F525		(012520—)	240-15-18
(—012519)	240-10-2	F510 (011958—) and F525	
F510 (011958—) and F525		(012520—)	240-15-20
(012520—)	240-10-4	Fuel Shut-off Solenoid Test Points	240-15-22
Ignition Circuit Operation—Operator On		PTO Circuit Test Points	
Seat	240-10-6	F510 (—011957) and F525	
Ignition System Operation—Operator Off		(—012519)	240-15-24
Seat		F510 (—011957) and F525	
F510 (—011957) and F525		(—012519)	240-15-26
(—012519)	240-10-8	F510 (011958—) and F525	
F510 (011958—) and F525		(012520—)	240-15-28
(012520—)	240-10-10	F510 (011958—) and F525	
Charging System Operation	240-10-12	(012520—)	240-15-30
PTO System Operation—Operator On		Charging and Discharge Light Circuit Test	
Seat	240-10-14	Points	240-15-32
Hourmeter, Low Fuel, Engine Oil Pressure,		Charging and Discharge Light	
Headlight System		Test-Continued	240-15-34
Hourmeter, Low Fuel, Engine Oil Pressure,		Hourmeter, Low Fuel and Oil Pressure	
Headlight System	240-10-16	Test Points	
Group 15—Diagnosis, Tests, and Adjustments		F510 (—011957) and F525	
Diagnostic Information	240-15-1	(—012519)	240-15-36
Fuse Block Identification	240-15-2	F510 (011958—100000) and F525	
Cranking Circuit Test Points		(012520—100000)	240-15-38
F510 (—011957) and F525		F510 (100001—) and F525	
(—012519)	240-15-4	(100001—)	240-15-40
F510 (011958—) and F525		Headlight Circuit Test Points-Optional . .	240-15-42
(012520—)	240-15-6	Common Circuit Tests	240-15-44
Ignition Power Circuit Test Points		Battery Test	240-15-45
Operator On Seat	240-15-8	Charge Battery	240-15-46
Off Seat—F510 (—011957) and		Battery Load Test	240-15-47
F525 (—012519)	240-15-10	Regulated Amperage Test	240-15-48
Off Seat—F510 (011958—) and		Regulated Voltage Test	240-15-49
F525 (012520—)	240-15-12	Unregulated Voltage Output Test	240-15-50
		Starter Solenoid Test	240-15-51
		Starter Amp Draw Test	240-15-52

Continued on next page

	Page		Page
Starter No-Load Amperage and RPM Test	240-15-53	Wiring Harness Legend	
Ignition Coil Air Gap Adjustment	240-15-54	F510 (—011957) and F525	
Ignition Coil Test		(—012519)	240-20-5
F510 (—100203) and F525		Electrical Schematic Legend	
(—100392)	240-15-55	F510 (011958—) and F525	
F510 (100204—) and F525		(012520—)	240-20-6
(100393—)	240-15-56	Electrical Schematic	
Ignition Module Test	240-15-56	F510 (011958—) and F525	
Spark Plug Cap Test—F510 (—100203) and		(012520—)	240-20-7
F525		Wiring Harness	
(—100392	240-15-57	F510 (011958—100000) and F525	
Spark Plug Gap Adjustment	240-15-58	(012520—100000)	240-20-8
Spark Test	240-15-59	Wiring Harness Legend	
Key Switch Test	240-15-60	F510 (011958—100000) and F525	
Flywheel Magnet Test	240-15-61	(012520—100000)	240-20-9
Brake Switch Test and Adjustment	240-15-62	Wiring Harness Legend	
Test PTO Switch		F510 (100001—) and F525	
F510 (—011957) and F525		(100001—)	240-20-10
(—012519)	240-15-63	Wiring Harness	
F510 (011958—120459) and F525		F510 (100001—) and F525	
(012520—121629)	240-15-64	(100001—)	240-20-11
F510 (120460—) and F525		Wiring Harness	
(12629—)	240-15-65	F510 and F525 with plug-in diodes	240-20-12
PTO Clutch Test	240-15-66	Wiring Harness Legend	
PTO Clutch Adjustment	240-15-67	F510 and F525 with plug-in diodes	240-20-13
Seat Switch Test	240-15-68		
Headlight Switch Test	240-15-69		
Oil Pressure Sender Switch Test	240-15-70		
Fuel Shut-off Solenoid Test	240-15-71		
Relay Test	240-15-72		
Low Fuel Sensor Test	240-15-73		
Ground Circuit Test	240-15-74		
Group 20—Wiring Schematic and Harness Diagram			
Schematic Information	240-20-1		
Electrical Schematic Legend			
F510 (—011957) and F525			
(—012519)	240-20-2		
Electrical Schematic			
F510 (—011957) and F525			
(—012519)	240-20-3		
Wiring Harness			
F510 (—011957) and F525			
(—012519)	240-20-4		

COMPONENT LOCATION INFORMATION

This group contains a component location drawing for the machine electrical system components.

Use this drawing when diagnosing an electrical problem and to help locate the components to be tested.

MX,24005CL,1 -19-23OCT95

240
05
1

ELECTRICAL SYSTEM COMPONENTS

A—Electrical System
Components
B—Low Oil Light
C—Low Fuel Light
D—Discharge Light
E—Brake Switch
F—Magneto

G—Hourmeter
H—PTO Switch
I—Headlight Switch
(Optional)
J—Ignition Switch
K—Stator

L—Seat Switch
M—Fuel Shut-Off Solenoid
N—Oil Sender
O—Ignition Module
P—Battery
Q—PTO Clutch

R—Starter
S—Fuel Sensor
T—Fuse Block
U—Relays
V—Regulator/Rectifier
W—Headlight (Optional)

NOTE: Early model shown, the style of PTO switch
may vary with the age of the machine.

240
05
2

MX,24005CL,2 -19-23OCT95

Ⓐ ELECTRICAL SYSTEM COMPONENTS

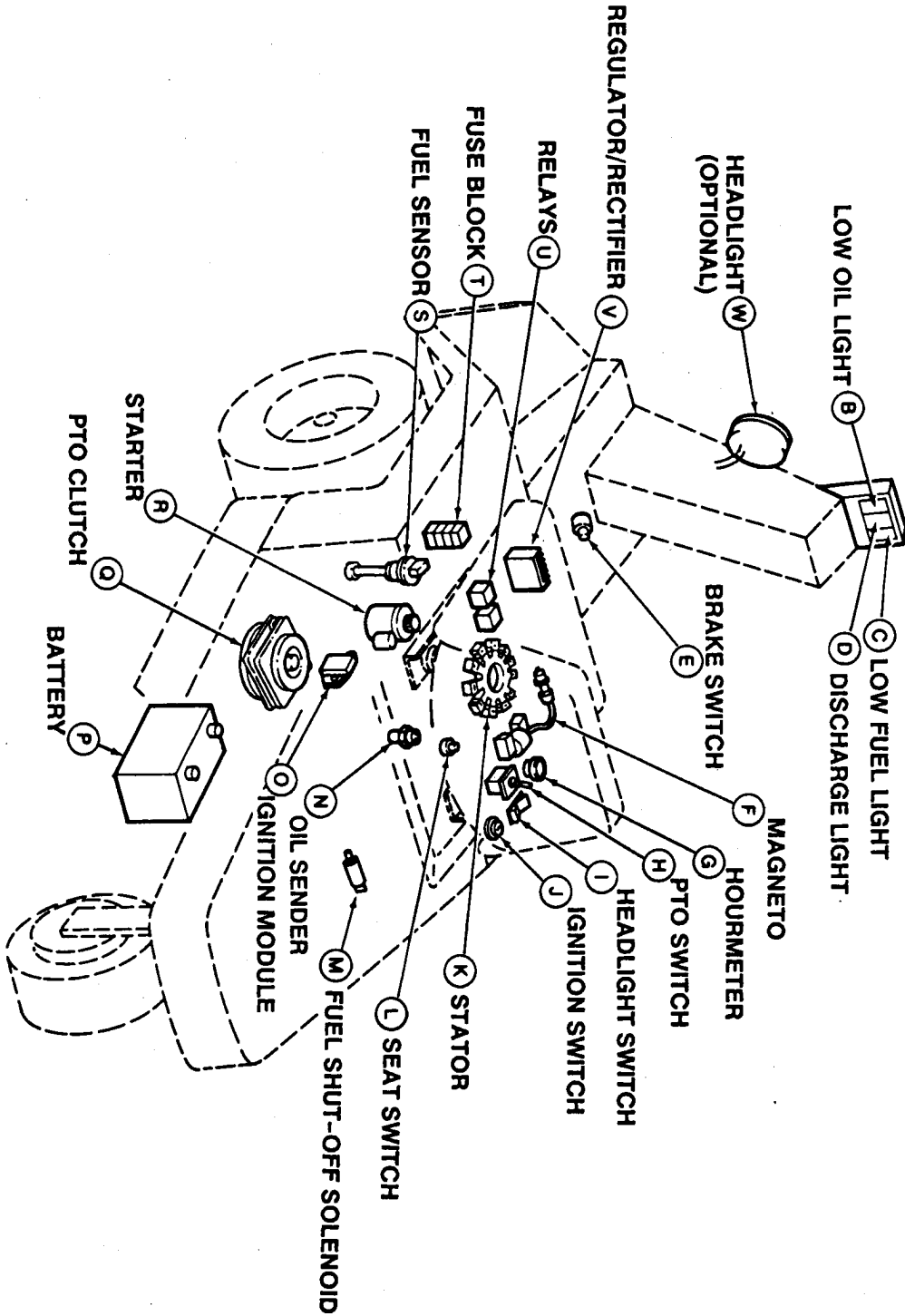

M52863 -UN-01SEP88

M52863

MX,24005CL,3 -19-23OCT95

240
05
4

ELECTRICAL THEORY OF OPERATION INFORMATION

This group divides the electrical system into individual components or circuits by function. Each circuit is isolated from the main wiring schematic and only shows the components that are used in it. The story contains information on function, component or circuit identification and theory of operation.

The circuit schematics are drawn with the components in the operating position, with the power, or battery positive, into them across the top and the ground, or battery negative, across the bottom.

COLOR IS USED TO IDENTIFY SUB-CIRCUITS AND MAY NOT MATCH THE ACTUAL COLORS OF THE WIRES ON THE UNIT.

The following systems or components are covered:

- Cranking System Operation—F510 (—011957) and F525 (—012519)
- Cranking System Operation—F510 (011958—) and F525 (012520—)
- Ignition Circuit Operation—Operator On Seat
- Ignition System Operation—Operator Off Seat—F510 (—011957) and F525 (—012519)
- Ignition System Operation—Operator Off Seat—F510 (011958—) and F525 (012520—)
- Charging System Operation
- PTO System Operation—Operator On Seat
- Engine Oil Pressure Lamp System Operation
- Low Fuel Lamp System Operation
- Hourmeter System Operation
- Headlight System Operation—Optional

WIRE COLOR ABBREVIATION

WIRE COLOR

Blu	Blue
Blu/Blk	Blue/Black
Blu/Red	Blue/Red
Blk	Black
Blk/Wht	Black/White
Blk/Yel	Black/Yellow
Brn	Brown
Brn/Wht	Brown/White
Brn/Yel	Brown/Yellow
Clr	Clear
Dk Blu	Dark Blue
Dk Brn/Lt Grn	Dark Brown/Light Green
Dk Brn/Red	Dark Brown/Red
Dk Brn/Yel	Dark Brown/Yellow
Dk Grn	Dark Green
Grn	Green
Grn/Wht	Green/White
Gry	Gray
Lt Blu	Light Blue
Lt Grn	Light Green
Org	Orange
Org/Wht	Orange/White
Pnk	Pink
Pur	Purple
Pur/Blk	Purple/Black
Pur/Wht	Purple/White
Red	Red
Red/Blk	Red/Black
Red/Blu	Red/Blue
Red/Wht	Red/White
Red/Yel	Red/Yellow
Tan	Tan
Wht	White
Wht/Blk	White/Black
Wht/Blu	White/Blue
Wht/Red	White/Red
Yel	Yellow
Yel/Blk	Yellow/Black
Yel/Red	Yellow/Red
Yel/Wht	Yellow/White

240
10
1

MX,24010CL,A1 -19-23OCT95

CRANKING SYSTEM OPERATION—F510 (—011957) AND F525 (—012519)

A—Cranking System
Operation
F510 (—011957) and
F525 (—012519)
B—Battery

C—Starter Motor
D—Starter Solenoid
E—Fusible Link
F—Ignition Switch
G—START

H—RUN
I—OFF
J—Safety/Neutral Start Fuse
K—PTO Switch
L—Brake Switch

M—ON
N—Power Circuit
O—Safety/Neutral Start
Circuit
P—Ground Circuit

Function:

The function of the cranking system is to energize the starting motor. In order to crank the engine, the ignition switch (F) must be in the START position (G), the PTO switch (K) must be OFF, and the master brake pedal must be depressed (brake switch [L] ON).

NOTE: The operator does not have to be on the seat (seat switch closed) to crank the engine; therefore, the seat switch is not considered part of this circuit.

Major Components:

- Battery
- Fusible link
- Ignition switch
- Fuse
- PTO switch
- Brake switch
- Starter
- Starter solenoid

Theory of Operation:

This system consists of two circuits. The **safety/neutral start circuit** prevents the engine from cranking if the PTO switch (K) is on or the master brake switch (L) is not ON (M). The **starter cranking circuit** provides a high current path to the starter motor (C) through the starter solenoid (D).

Safety/Neutral Start Circuit:

When the ignition switch (F) is turned to the START position (G), current flows from the battery (B) positive terminal to a common tie point on the starter motor, through a fusible link (E), and through the ignition switch. From the ignition switch, current flows through the safety/neutral start 20 amp fuse (J) through the PTO switch (K) (PTO OFF), through the brake switch (L) (master brake depressed), and back to the ignition switch S1 terminal. Current continues through the ignition switch to the starter solenoid (D) for solenoid engagement.

The solenoid is engaged by current flowing through both pull-in and hold-in windings, pulling in the plunger. When main contacts close, both ends of pull-in windings have the same voltage so current through pull-in windings stops. Current continues through hold-in winding, keeping solenoid engaged while the starter motor cranks the engine.

Starter Cranking Circuit:

With starter solenoid (D) engaged by the hold-in windings, high current flows from the battery (B) through the starter solenoid contacts, to the starter motor (C) magnetic field and armature windings. This current creates strong magnetic fields, causing armature to rotate, engaging the bendix gear into the engine flywheel and cranking the engine.

MX,24010CL,A2 -19-23OCT95

(A) CRANKING SYSTEM OPERATION — F510 (—011957) AND F525 (—012519)

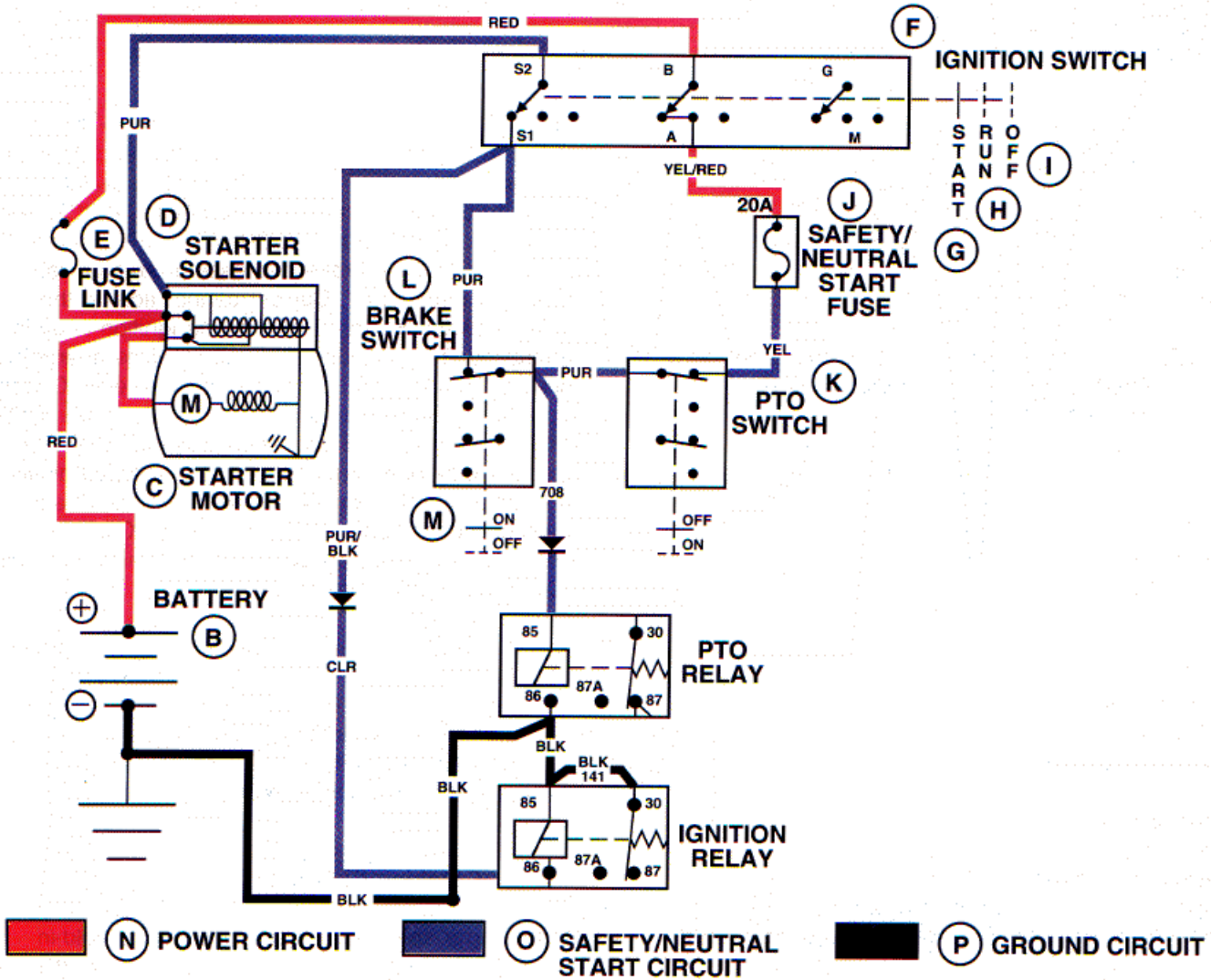

240
10
3

MXC45954
-19-

MXC45954

MX.24010CLA3 -19-23OCT95

CRANKING SYSTEM OPERATION—F510 (011958—) AND F525 (012520—)

A—Cranking System Operation
F510 (011958—) and
F525 (012520—)
B—Battery
C—Starter Motor

D—Starter Solenoid
E—Fusible Link
F—Ignition Switch
G—START
H—RUN

I—OFF
J—Safety/Neutral Start Fuse
K—PTO Switch
L—Brake Switch
M—PTO Relay

N—Ignition Relay
O—Power Circuit
P—Safety/Neutral Start Circuit
Q—Ground Circuit

Function:

The function of the cranking system is to energize the starting motor. In order to crank the engine, the ignition switch (F) must be in the START position (G), the PTO switch (K) must be OFF, the master brake pedal must be depressed (brake switch [L] ON), and the ignition relay (N) MUST be energized.

NOTE: The operator does not have to be on the seat (seat switch closed) to crank the engine. Therefore, the seat switch is not consider part of this circuit.

Major Components:

- Battery
- Fusible link
- Ignition switch
- Fuse
- PTO switch
- Brake switch
- Ignition relay
- Starter
- Starter solenoid

Theory of Operation:

This system consists of two circuits. The **safety/neutral start circuit** prevents the engine from cranking if the PTO switch (K) is on or the master brake (L) is not ON. The **starter cranking circuit** provides a high current path to the starter motor (C) through the starter solenoid (D).

Safety/Neutral Start Circuit:

When the ignition switch (F) is turned to the START position (G), current flows from the battery (B)

positive terminal to a common tie point on the starter solenoid (D), through a fusible link (E), and through the ignition switch (F). From the ignition switch, current flows through the safety/neutral start 20 amp fuse (J) to the PTO switch (K) (PTO OFF), brake switch (L) (master brake depressed), and ignition relay (N) terminal 87. Current cannot flow to the ignition switch S1 terminal until the ignition relay is energized. The ignition relay coil receives energizing current from terminal 87 of the ignition relay. Current from the ignition relay terminal 87 flows to the ignition relay coil terminal 86 and energizes the relay. The ignition relay now has continuity between terminals 30 and 87. Current from terminal 87 flows to 30 and then to the ignition switch terminal S1. Current continues from ignition switch to the starter solenoid (D) for solenoid engagement.

The solenoid is engaged by current flowing through both pull-in and hold-in windings, pulling in the plunger. When main contacts close, both ends of pull-in and hold-in windings have the same voltage so current through pull-in windings stops. Current continues through hold-in winding, keeping solenoid engaged.

Starter Cranking Circuit:

With starter solenoid (D) engaged by the hold-in windings, high current flows from the battery (B) through the starter solenoid contacts, starter motor (C) magnetic field, and armature windings. This current creates strong magnetic fields, causing armature to rotate, engaging the bendix gear into the engine flywheel and cranking the engine.

**(A) CRANKING SYSTEM OPERATION —
F510 (011958—) AND F525 (012520—)**

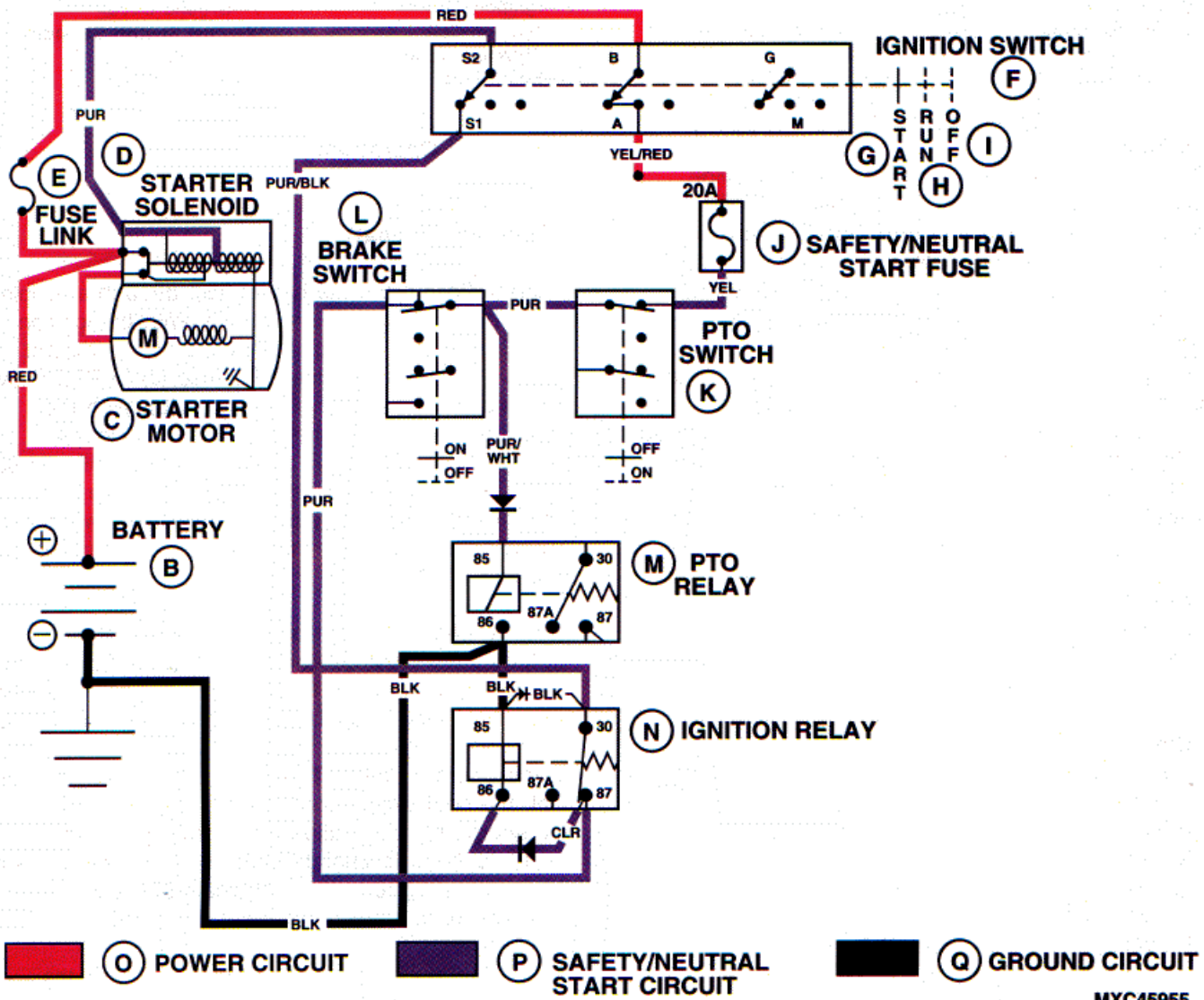

MXC45955

MX_24010CLA_3A -19-23OCT95

IGNITION CIRCUIT OPERATION—OPERATOR ON SEAT

A—Ignition Circuit
(Operator On Seat)
B—Battery
C—Starter Motor
D—Starter Solenoid
E—Fusible Link
F—Ignition Switch

G—START
H—RUN
I—OFF
J—Engine/PTO Fuse
K—PTO Relay
L—Seat Switch
M—Ignition Relay

N—Safety/Neutral Start Fuse
O—Fuel Shutoff Solenoid
P—Ignition Module
Q—Ignition Coil
R—Flywheel Magnet
S—Spark Plug

T—Power Circuit
U—Seat Switch Circuit
V—Ground Circuit
W—Fuel Shutoff Solenoid
Circuit
X—Ignition Circuit

Function:

The function of the ignition system is to provide current to the spark plug (S) to ignite the fuel/air mixture in the combustion chamber. The ignition system is a transistor-controlled magneto design. The magneto produces its own electricity by rotating a flywheel-mounted magnet (R) past the ignition coil (Q). The coil provides high voltage to the spark plug through electromagnetic induction. To shut off the engine the ignition coil is grounded out. To prevent the system from being grounded, current is provided to the ignition relay (M) through two circuits. These circuits operate under different sets of conditions: operator on seat; or operator off seat, PTO in OFF position, and master brake applied.

Major Components:

- Battery
- Ignition switch
- Fuses
- PTO switch
- Brake switch
- Seat switch
- Ignition relay
- PTO relay
- Ignition module
- Ignition coil
- Spark plug
- Flywheel magnet

Theory of Operation:**Ignition Circuit:
(Operator on seat)**

Current flows from the battery (B), through a fusible link (E), to the ignition switch (F). With the ignition switch in START (G) or RUN (H) position, current flows through the engine/PTO fuse (J) to PTO relay terminal 87 and to the seat switch (L). With the operator on the seat the seat switch is closed, allowing current to flow through terminals 86 and 85 of the ignition relay. This energizes the relay. The energized ignition relay breaks contact between relay terminals 87A and 30, thus preventing grounding of the ignition coil (Q).

For the engine to start and run, the fuel shutoff solenoid (O) must be energized. Current flows from the safety/neutral start fuse (N) to the solenoid whenever the ignition switch is in the start or run position.

If the operator gets off the seat without master brake set, the seat switch contacts are opened de-energizing the ignition relay causing the ignition relay contacts to change state. With the ignition relay in a non-energized state, terminals 87A and 30 are connected, grounding out the ignition coil.

When the ignition switch is turned OFF with the operator on the seat, the ignition coil is grounded through terminals "M" and "G" of the ignition switch.

MX,24010CL,A4 -19-23OCT95

A IGNITION CIRCUIT - OPERATOR ON SEAT

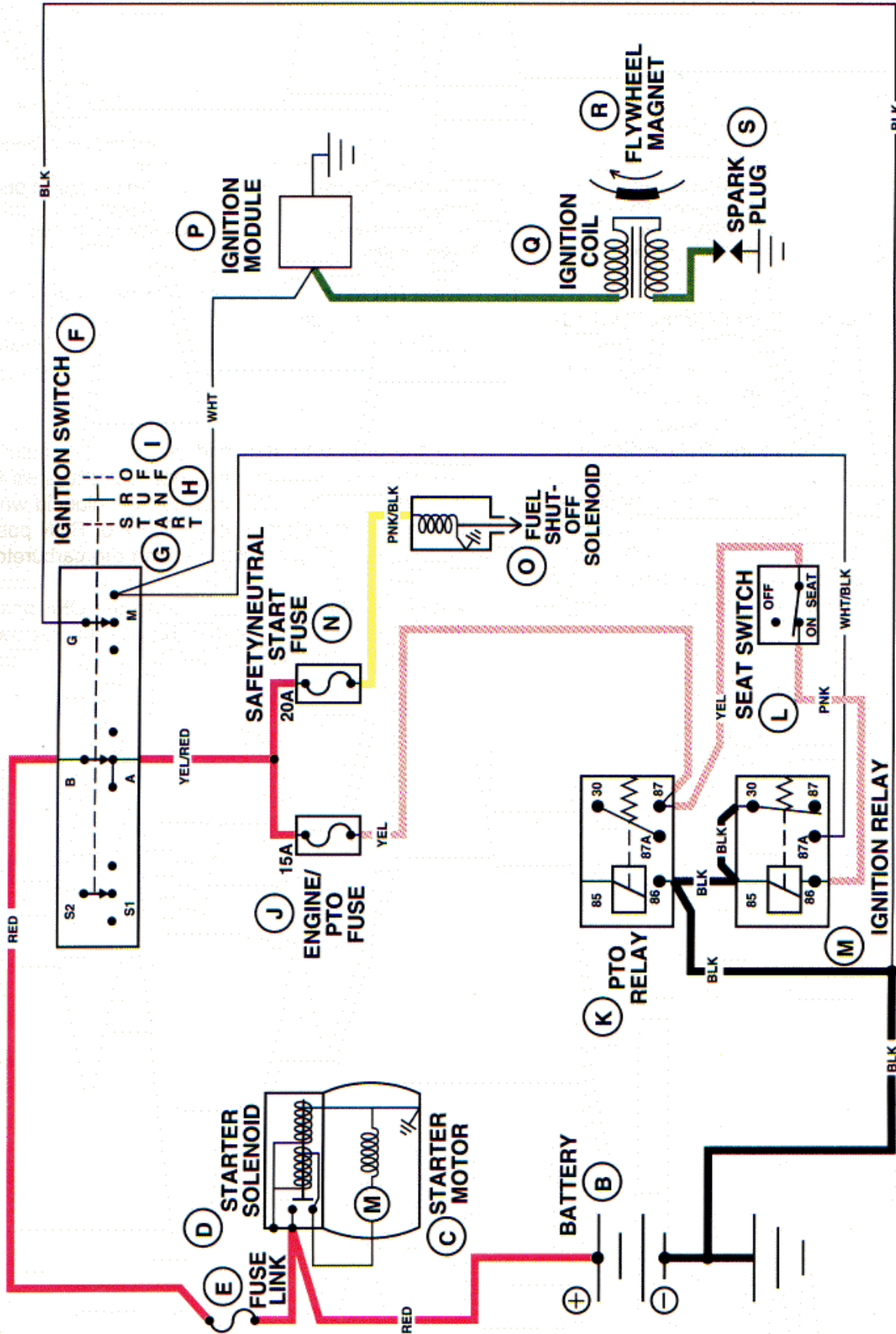

- █ **(T)** POWER CIRCUIT
- █ **(W)** FUEL SHUT-OFF SOLENOID CIRCUIT
- █ **(U)** SEAT SWITCH CIRCUIT
- █ **(X)** IGNITION CIRCUIT
- V **(V)** GROUND CIRCUIT

MXC48186

240
10
7

MXC48186 -19-

IGNITION SYSTEM OPERATION—OPERATOR OFF SEAT—F510 (—011957) AND F525 (—012519)

A—Ignition System Operation
F510 (—011957) and
F525 (—012519)
(Operator Off Seat/
PTO OFF/
Brake Applied)
B—Battery
C—Starter Motor
D—Starter Solenoid

E—Fusible Link
F—Ignition Switch
G—START
H—RUN
I—OFF
J—Safety/Neutral Start Fuse
K—Engine/PTO Fuse
L—PTO Switch
M—Brake Switch

N—ON
O—PTO Relay
P—Ignition Relay
Q—Seat Switch
R—Fuel Shutoff Solenoid
S—Ignition Module
T—Ignition Coil
U—Flywheel Magnet
V—Spark Plug

W—Power Circuit
X—Seat Switch Circuit
Y—Ground Circuit
Z—Fuel Shutoff Solenoid
Circuit
AA—Safety/Neutral Start
Circuit
AB—Ignition Circuit

**Ignition Circuit:
(Operator off the seat/PTO OFF/Brake applied)**

Current flows from the battery (B), through a fusible link (E), to the ignition switch (F). With the ignition switch in RUN position (H), current flows through the safety/neutral start fuse (J) to the PTO switch (L). With the PTO switch OFF current flows through the brake switch (M) (brake applied), to a connector at the ignition switch, and through terminals 86 and 85 of the ignition relay, energizing the relay (P). The energized ignition relay breaks contact between relay terminals 87A and 30, thus preventing grounding of the ignition coil (T).

If the PTO switch is ON or the brake released, current to the ignition relay is interrupted. With the ignition relay in a non-energized state, terminals 87A and 30 are connected which provides a path to ground the ignition coil.

For the engine to start and run, the fuel shutoff solenoid (R) must be energized. Current flows from the safety/neutral start fuse to the solenoid whenever the ignition switch is in the START or RUN position. The solenoid is grounded through the carburetor.

When the key switch is moved to the OFF position, the ignition coil is grounded through the key switch, shutting off the engine.

MX,24010CL,A6 -19-23OCT95

240
10
8

**(A) IGNITION SYSTEM OPERATION - F510 (-011957) AND F525 (-012519)
 -OPERATOR OFF SEAT
 -PTO OFF
 -BRAKE APPLIED**

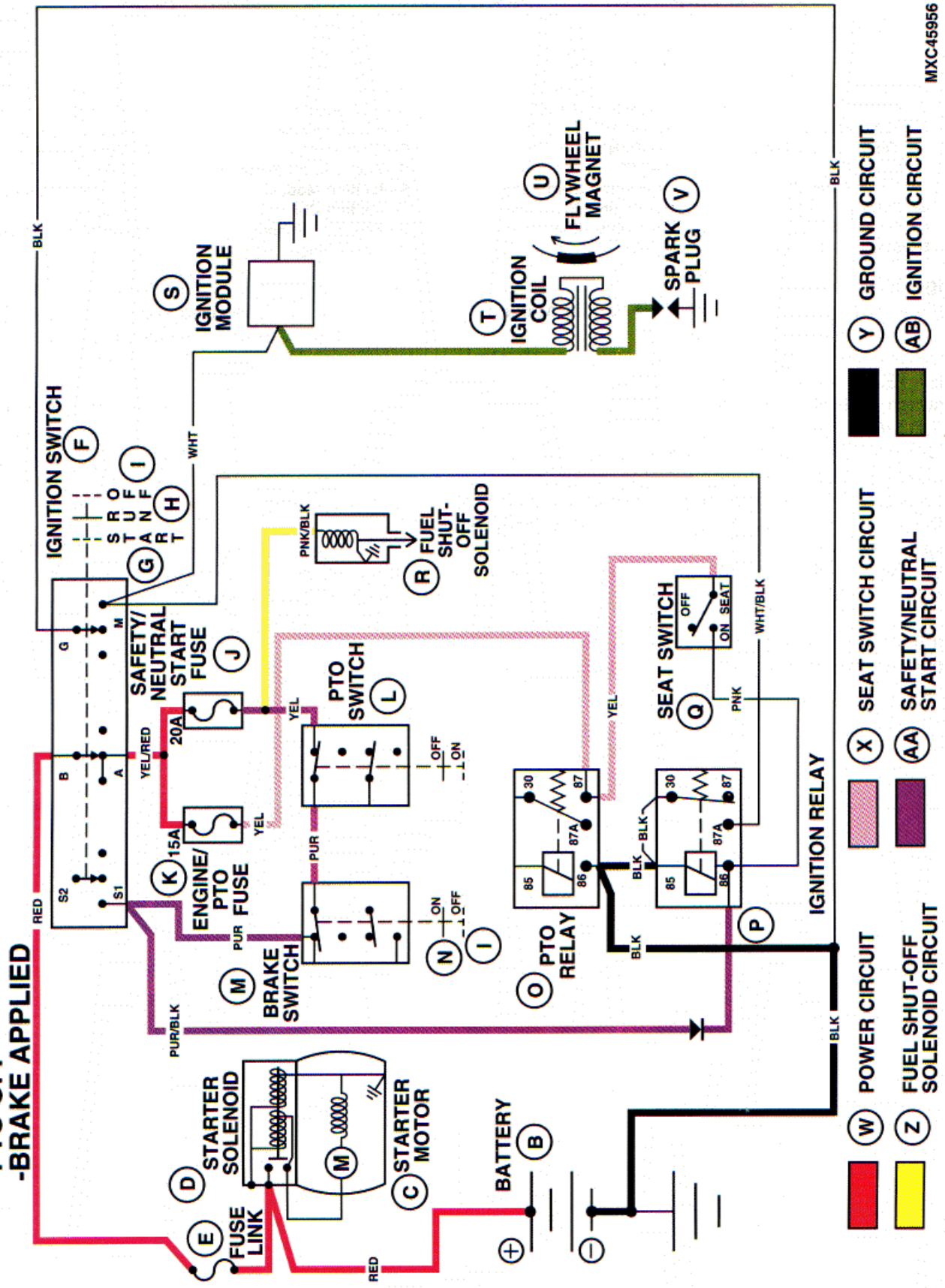

MXC45956

240
10
9

MXC45956 -19-

IGNITION SYSTEM OPERATION—OPERATOR OFF SEAT—510 (011958—) AND F525 (012520—)

A—Ignition System Operation
F510 (011958—) and
F525 (012520—)
(Operator Off Seat/
PTO OFF/
Brake Applied)
B—Battery
C—Starter Motor
D—Starter Solenoid

E—Fusible Link
F—Ignition Switch
G—START
H—RUN
I—OFF
J—Neutral Start Fuse
K—Engine/PTO Fuse
L—PTO Switch
M—Brake Switch

N—ON
O—PTO Relay
P—Ignition Relay
Q—Seat Switch
R—Fuel Shutoff Solenoid
S—Ignition Module
T—Ignition Coil
U—Flywheel Magnet
V—Spark Plug

W—Power Circuit
X—Seat Switch Circuit
Y—Ground Circuit
Z—Fuel Shutoff Solenoid
Circuit
AA—Safety/Neutral Start
Circuit
AB—Ignition Circuit

**Ignition Circuit:
(Operator off the seat/PTO OFF/Brake applied)**

Current flows from the battery (B), through a fusible link (E), to the ignition switch (F). With the ignition switch in RUN position (H), current flows through the Safety/Neutral Start fuse (J) to the PTO switch (L). With the PTO switch OFF current flows through the brake switch (brake applied), to the ignition relay terminal 87, and then through terminals 86 and 85 of the ignition relay, energizing the relay. The energized ignition relay breaks contact between relay terminals 87A and 30, thus preventing grounding of the ignition coil.

If the PTO switch is ON or the brake released with the operator off the seat (seat switch open), current

to the ignition relay is interrupted. With the ignition relay in a non-energized state, terminals 87A and 30 are connected which provides a path to ground the ignition coil shutting off the engine.

For the engine to start and run, the fuel shutoff solenoid must be energized. Current flows from the safety start fuse to the solenoid whenever the ignition switch is in the START or RUN position. The solenoid is grounded through the carburetor.

When the key switch is moved to the OFF position, the ignition coil is grounded through the key switch, shutting off the engine.

MX,24010CL,A6A -19-23OCT95

240
10
10

**(A) IGNITION SYSTEM OPERATION - F510 (011958-) AND F525 (012520-)
 -OPERATOR OFF SEAT
 -PTO OFF
 -BRAKE APPLIED**

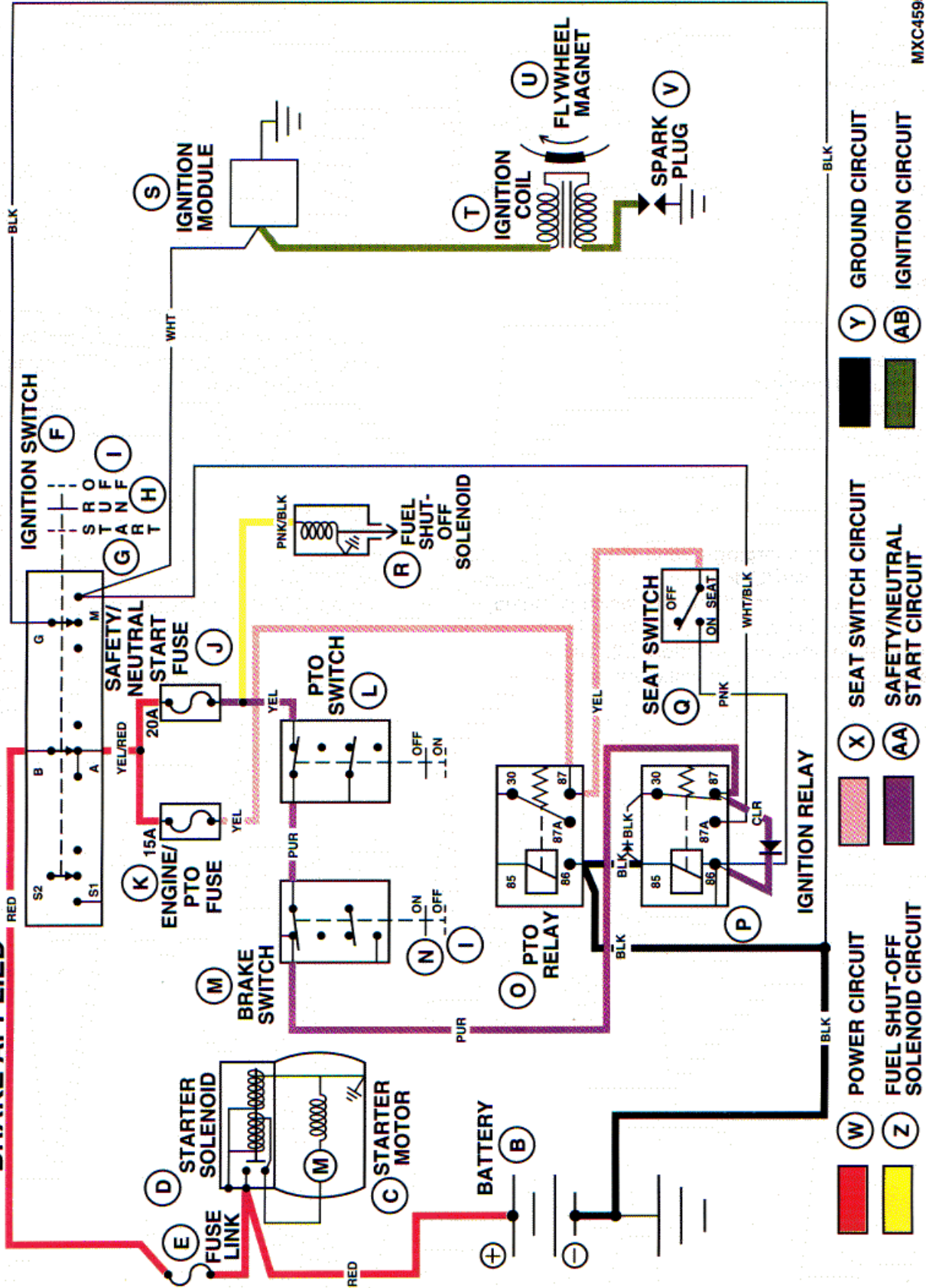

MXC45957

240
10
11

-19-
MXC45957

MX.24010CLA7A -19-23OCT95

CHARGING SYSTEM OPERATION

A—Charging System
 B—Battery
 C—Starter Motor
 D—Starter Solenoid
 E—Fusible Link

F—Ignition Switch
 G—START
 H—RUN
 I—OFF
 J—Safety/Neutral Start Fuse

K—Charge Fuse
 L—Regulator/Rectifier
 M—Stator
 N—Discharge Light
 O—Battery Charging Circuit

P—Discharge Light Circuit
 Q—Stator Output Circuit
 R—Battery Sensing Circuit
 S—Ground Circuit

Function:

The function of the charging system is to provide current produced by the stator to maintain the state of battery charge.

Major Components:

- Battery
- Ignition switch
- Fuses
- Regulator/rectifier
- Stator
- Discharge light

Theory of Operation:

The charging system consists of five circuits:

- The **battery charging circuit (O)** uses the voltage regulator/rectifier (L) to convert AC current produced by the stator (M), to DC current which is routed through the charging fuse (K) and fusible link (E), to the positive pole for the battery (B). The voltage regulator keeps charging voltage at a safe level.

- The **battery sensing circuit (R)** uses the voltage regulator/rectifier to sense current draw from the battery. The voltage regulator/rectifier then directs charge voltage from the **stator output circuit (Q)** to the battery as needed.
- The **discharge light circuit (P)** is activated when the ignition switch (F) is in RUN position (G) and no current is being supplied by the charging system. Current flows from the battery through the fusible link, ignition switch, and safety/neutral start fuse (J) to the regulator/rectifier. The regulator/rectifier passes current to the discharge light (N).
- The **stator output circuit (Q)** is generating voltage whenever the engine is cranking or running. The regulator/rectifier (L) regulates the amount of voltage required and rectifies (changes) the stator alternating current (AC) into direct current (DC) for the entire electrical system.
- The **ground circuit (S)** provides a path to ground for the regulator/rectifier and discharge light.

240
10
12

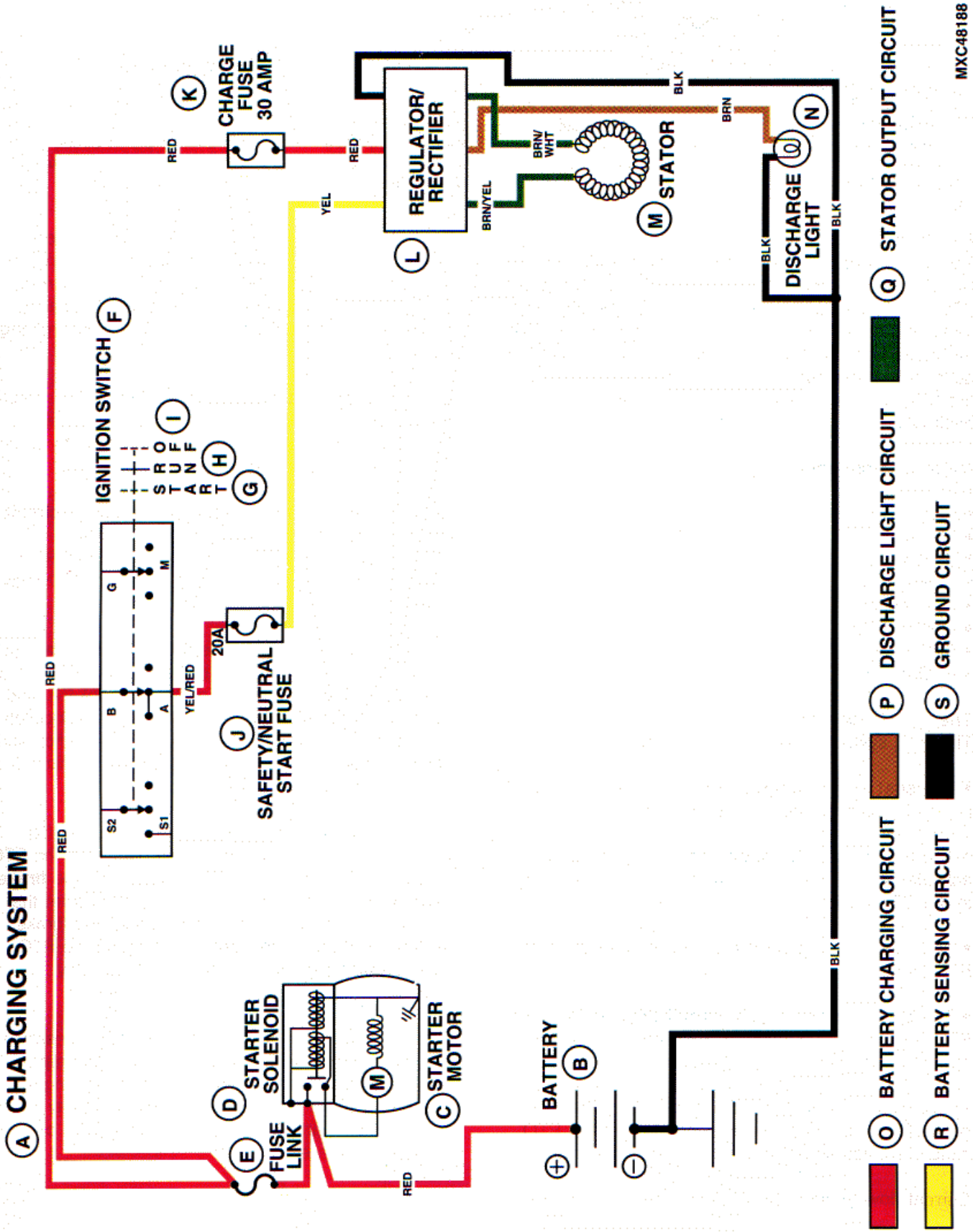

MXC48188

240
10
13

MXC48188 -19-

PTO SYSTEM OPERATION—OPERATOR ON SEAT

A—PTO System
(Operator On Seat)
B—Battery
C—Starter Motor
D—Starter Solenoid
E—Fusible Link
F—Ignition Switch
G—START

H—RUN
I—OFF
J—Safety/Neutral Start Fuse
K—Engine/PTO Fuse
L—PTO Switch
M—Brake Switch
N—ON

O—PTO Relay
P—PTO Clutch
Q—Seat Switch
R—Ignition Relay
S—Ignition Module
T—Ignition Coil
U—Flywheel Magnet

V—Spark Plug
W—Power Circuit
X—Initial Energizing Circuit
Y—Brake Switch Circuit
Z—PTO Clutch Circuit
AA—Seat Switch Circuit
AB—Ground Circuit

Function:

The function of the PTO system is to provide current to activate the PTO clutch (P). In order to engage the PTO, and keep the engine running, the operator must be on the seat and the brake must be disengaged. If the brake is applied, the PTO will stop. If the operator gets off the seat the engine will stop. To reactivate the PTO, the switch must be cycled OFF, and then back ON.

Major Components:

- Battery
- Ignition switch
- Fuses
- Seat switch
- Brake switch
- PTO switch
- Ignition relay
- PTO relay
- PTO clutch

Theory of Operation:

The PTO system consists of four circuits:

- The **seat switch circuit (AA)** activates the ignition relay (R) when the operator is on the seat.
- The PTO switch (L) **initial energizing circuit (X)** activates the PTO relay (O) when the PTO switch is in the OFF position.
- The **PTO clutch circuit (Z)** supplies current to the PTO clutch (P).
- The **brake switch safety circuit (Y)** maintains the PTO relay in the engaged position when the brake switch (M) is OFF (brake released).

All four circuits are involved in the initial engagement of the PTO clutch. Continued operation of the PTO clutch involves all but the initial energizing circuit.

Current flow through the PTO system is as follows:

Current flows from the battery (B) to the ignition switch (F) through a fusible link (E) in the wiring. With the ignition switch in the RUN position (H), current flows through the ignition switch into two separate circuits: the **seat switch** and **PTO initial energizing circuits**.

Current in the **seat switch circuit (AA)** flows through the engine/PTO fuse (K), seat switch (Q) (operator on seat), ignition relay terminals 86/85 and to ground. This energizes the ignition relay.

Current in the PTO switch **initial energizing circuit (X)** flows through the safety/neutral start fuse (J), PTO switch (L) (switch in OFF position), and PTO relay terminals 85/86. This energizes the PTO relay (O).

Current flow continues in the **PTO clutch circuit (Z)** through terminals 87/30 of the energized PTO relay, the PTO switch (L) (switch in ON position) (N), and the PTO clutch (P). Current through the PTO clutch activates an electromagnet, engaging the clutch and allowing power transfer from the engine crankshaft to the PTO sheave.

Switching the PTO switch to the ON position (N) interrupts current flow that initially energized the PTO relay. The PTO relay is kept energized by the **brake switch circuit (Y)** which picks up current from the PTO relay terminal 30, routes it through the brake switch (M) (brake released), and through the PTO relay terminals 85/86, keeping the PTO relay engaged.

If the operator leaves the seat with the PTO switch ON, current flow to the ignition relay is interrupted, de-energizing the relay. As the solenoid changes state, contact is made between solenoid relay terminals 87A and 30, grounding the ignition coil, shutting off the engine.

When the key switch is moved to the OFF position, the ignition coil is grounded through the key switch, shutting off the engine.

(A) PTO SYSTEM - OPERATOR ON SEAT

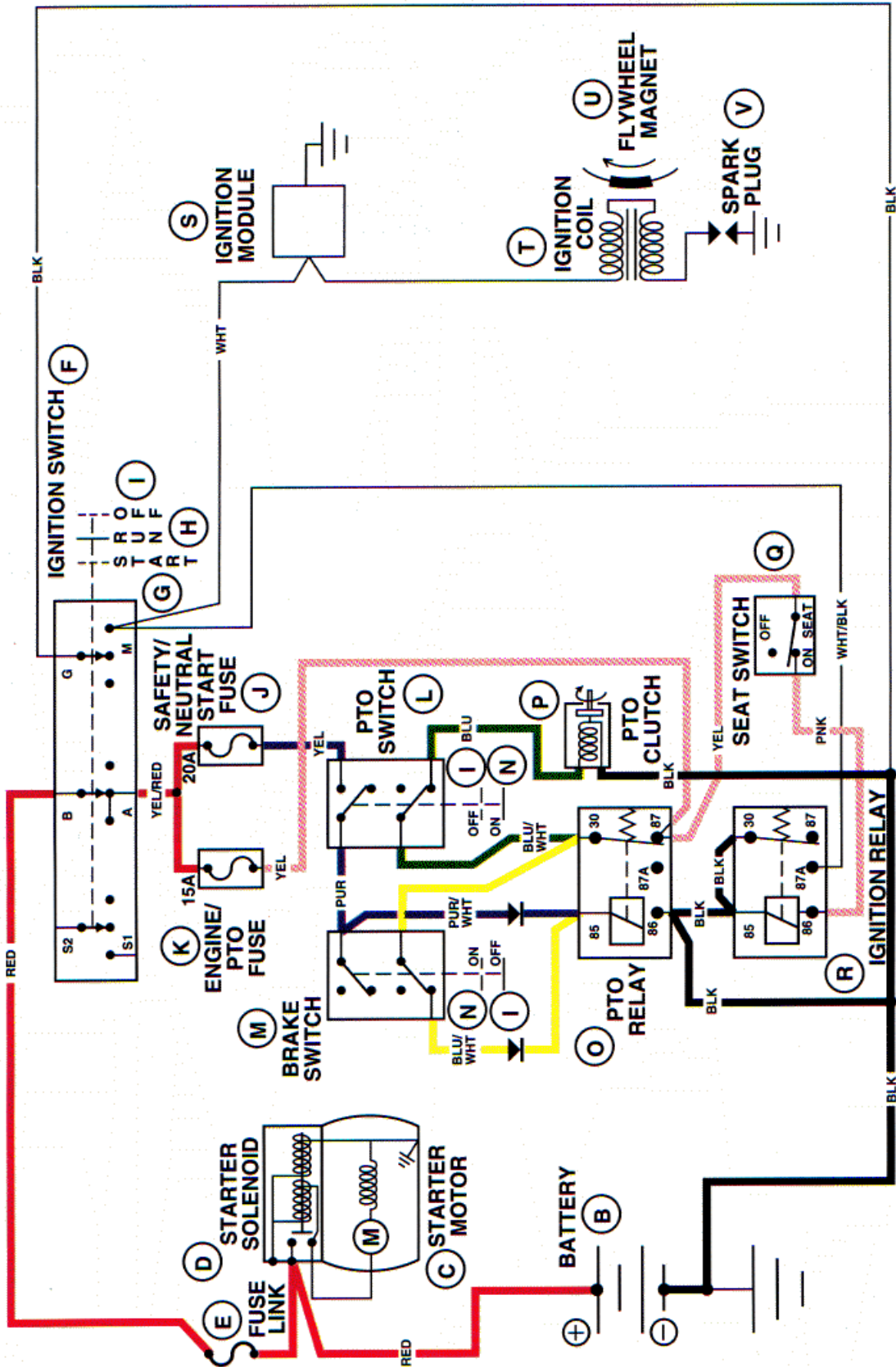

- █ (W) POWER CIRCUIT
- █ (Z) PTO CLUTCH CIRCUIT
- █ (X) INITIAL ENERGIZING CIRCUIT
- █ (Y) BRAKE SWITCH CIRCUIT
- AB (AB) GROUND CIRCUIT
- AA (AA) SEAT SWITCH CIRCUIT

MXC48189

240
10
15

MXC48189 -19-

HOURMETER, LOW FUEL, ENGINE OIL PRESSURE, AND HEADLIGHT SYSTEM OPERATION

A—Hourmeter, Low Fuel Light, Engine Oil Pressure, and Headlight System

B—Battery

C—Starter Motor

D—Starter Solenoid

E—Fusible Link

F—Ignition Switch

G—START

H—RUN

I—OFF

J—Safety/Neutral Start Fuse

K—Headlight Fuse

L—PTO Switch

M—Headlight Switch (Optional)

N—Headlights (Optional)

O—Hourmeter

P—Low Fuel Light

Q—Oil Pressure Light

R—Fuel Sensor

S—Oil Pressure Sensor

T—Discharge Light

U—Power Circuit

V—Headlight Circuit

W—Hourmeter Circuit

X—Engine Oil Pressure Light

Circuit

Y—Low Fuel Light Circuit

Z—Ground Circuit

Function:

The function of this system is to provide power for the hourmeter, low fuel, engine oil pressure, and headlight circuits. In order for the system to function, the ignition switch must be in the START or RUN position.

Major Components:

- Battery
- Ignition switch
- Fuses
- Headlight switch
- Headlight
- Indicator lights
- Hourmeter
- Low fuel sensor
- Oil sender

Theory of Operation:

There are five circuits which make up this system:

- Hourmeter circuit (W)
- Low fuel light circuit (Y)
- Engine oil pressure light circuit (X)
- Headlight circuit (V) (Optional)
- Ground circuit (Z)

When the ignition switch (F) is turned to the RUN (H) or START (G) position, current flows from the battery (B) through the fusible link (E) and ignition switch to the headlight (V), hourmeter (W) and indicator light circuits (X and Y).

The **headlight circuit (V)** routes current through the headlight fuse (K) and light switch (M) (ON position) to the headlights (N).

The **hourmeter circuit (W)** runs whenever the ignition switch is in the START or RUN position. Current flows from the "A" terminal of ignition switch, through the safety/neutral start fuse (J) to the PTO switch (L) and hourmeter (O).

Current for the **low fuel light (Y)** and **engine oil pressure light circuits (X)** is also supplied through the neutral start fuse when the ignition switch is in the START or RUN position. The low fuel light (P) comes on when the fuel sensor (R) closes completing the path to ground. The engine oil pressure light (Q) comes on until oil pressure opens the oil pressure sensor (S) interrupting the path to ground.

The **ground circuit (Z)** must be good to enable the other circuits to operate properly.

MX,24010CL,A12 -19-23OCT95

A HOURMETER, LOW FUEL LIGHT, ENGINE OIL PRESSURE AND HEADLIGHT

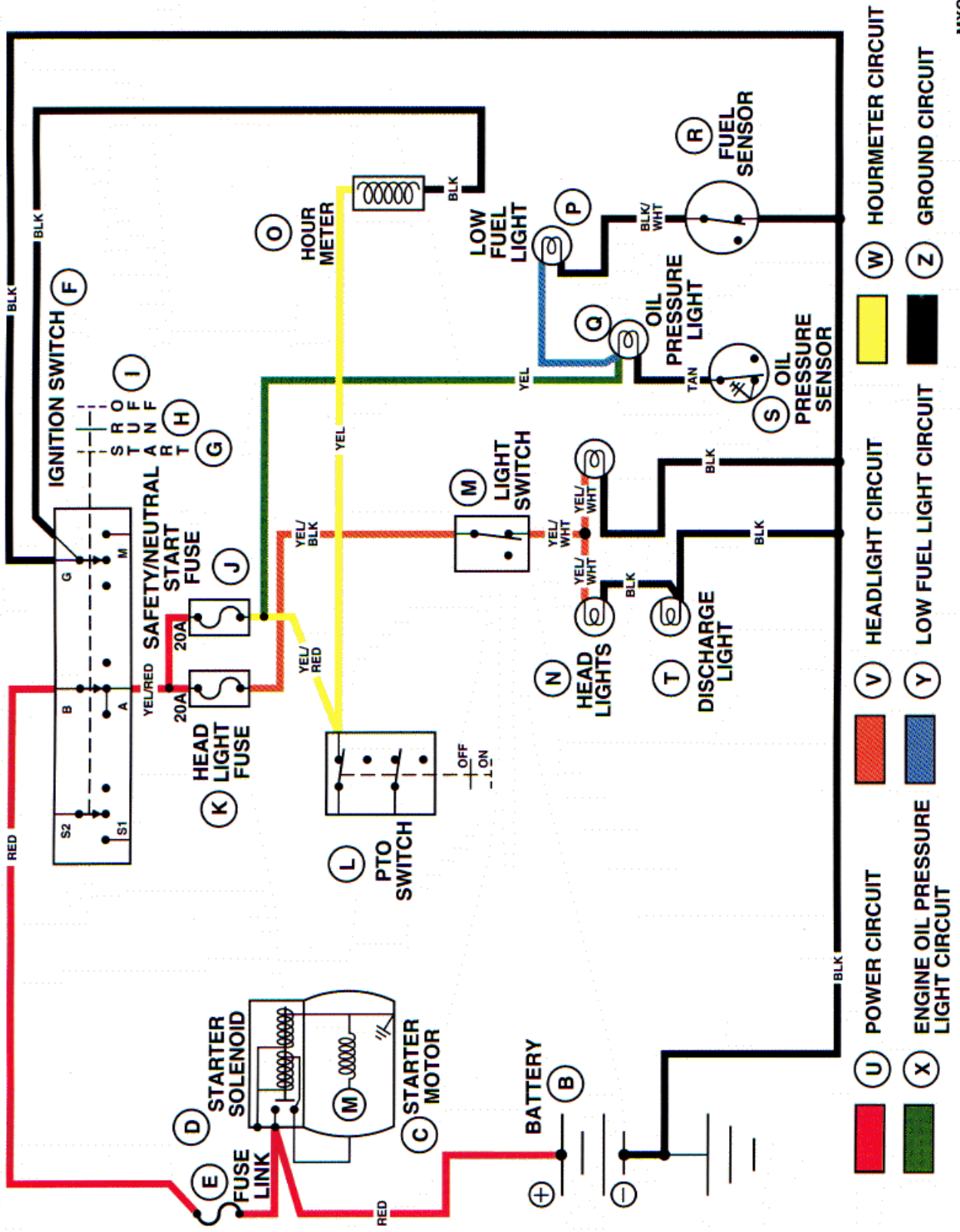

MXC45958

240
10
17

240
10
18

DIAGNOSTIC INFORMATION

The diagnostic information in this group is used to test components related to a specific problem or system. Select a symptom or system from the list and follow the test procedures under that heading. The symptom or system headings are:

- Cranking Circuit Test Points—F510 (—011957) and F525 (—012519)
- Cranking Circuit Test Points—F510 (011958—) and F525 (012520—)
- Ignition Power Circuit Test Points—Operator On Seat
- Ignition Power Circuit Test Points—Off Seat—F510 (—011957) and F525 (—012519)
- Ignition Power Circuit Test Points—Off Seat—F510 (011957—) and F525 (012519—)
- Magneto and Ground Circuit Test Points—F510 (—011957) and F525 (—012519)
- Magneto and Ground Circuit Test Points—F510 (011957—) and F525 (012519—)
- Fuel Shut-off Solenoid Test Points
- PTO Circuit Test Points—F510 (—011957) and F525 (—012519)
- PTO Circuit Test Points—F510 (011958—) and F525 (012520—)
- Charging and Discharge Light Circuit Test Points
- Hourmeter, Low Fuel, and Oil Pressure Light Circuit Test Points—F510 (—011957) and F525 (—012519)
- Hourmeter, Low Fuel, and Oil Pressure Light Circuit Test Points—F510 (011958—100000) and F525 (12520—100000)
- Hourmeter, Low Fuel, and Oil Pressure Light Circuit Test Points—F510 (100001—) and F525 (100001—)
- Headlight Circuit Test Points—Optional

The diagnostic procedure lists:

- Test conditions
- Test sequence
- Test location
- Normal reading
- Check or test to perform if reading is not normal

When performing the test or check, be sure to set your machine up to the test conditions listed and follow the sequence carefully. The middle “Normal” column gives the reading or condition that should be obtained when performing the test or check. If the results of the test or check are not normal, perform the test, check, or adjustment listed in the third “If Not Normal” column to repair the malfunction. The detailed tests or adjustments referred to in the “If Not Normal” column are located at the end of this group.

The system diagram that accompanies each test procedure is drawn to resemble machine components. The key number on the art matches the number in the “Test Location” column and the arrow points to the exact point the test is to be made.

MX,24015CL,A1 -19-23OCT95

240
15
1

FUSE BLOCK

A—Headlight Fuse (20 Amp)—Protects Light Switch and Headlights

B—Neutral Start Fuse (20 Amp)—Protects PTO switch, brake switch, ignition relay, fuel shutoff solenoid, low fuel light and sensor, oil pressure light and sensor, regulator/rectifier, hourmeter.

C—PTO Fuse (15 Amp)—Protects PTO relay, seat switch, ignition relay, PTO switch, PTO clutch and brake switch.

D—Charge Fuse (30 Amp)—Protects regulator/rectifier.

E—Bussbar—Connects the top three fuses to hot side of power circuit.

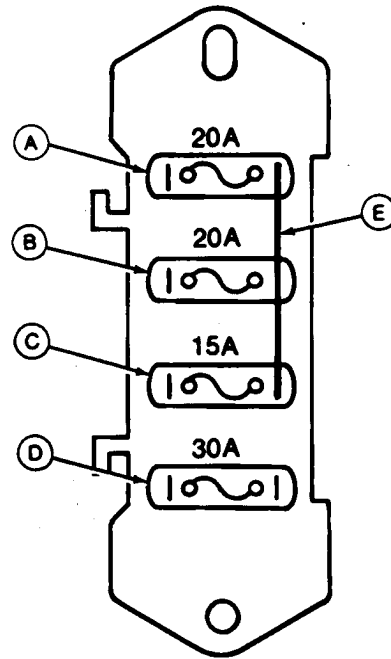

240
15
2

MX.24015CL.A1A -19-23OCT95

M53493 -JUN-25AUG89

**CRANKING CIRCUIT TEST POINTS—F510
(—011957) AND F525 (—012519)**

Conditions:

- Transmission in neutral
- Park brake engaged
- PTO disengaged
- Ignition switch in RUN position
- Meter negative (—) lead on battery negative (—) terminal
- Meter positive (+) lead on numbered test point

240
15
4

Test Location	Normal	If Not Normal
1. Battery positive (+) terminal	11.8—13.2 volts	Test battery.
2. Ignition switch terminal B	Battery voltage	Check battery cable connection, starter tie point, harness connector, fusible link, and red wire.
3. Ignition switch terminal A	Battery voltage	Test ignition switch.
4. 20 amp fuse (hot side)	Battery voltage	Check yel/red wire and connectors.
5. 20 amp fuse (protected side)	Battery voltage	Check fuse.
6. PTO switch	Battery voltage	Check yel and yel/red wires.
7. PTO switch	Battery voltage	Test PTO switch.
8. Brake switch	Battery voltage	Check pur wire.
9. Brake switch	Battery voltage	Test brake switch.
10. Ignition switch terminal S1	Battery voltage	Check pur wire.
Conditions:		
• Ignition switch in start position		
11. Ignition switch terminal S2	Battery voltage	Test ignition switch.
12. Starter solenoid terminal	Battery voltage	Check pur wire.
		Battery voltage - test starter solenoid and motor.

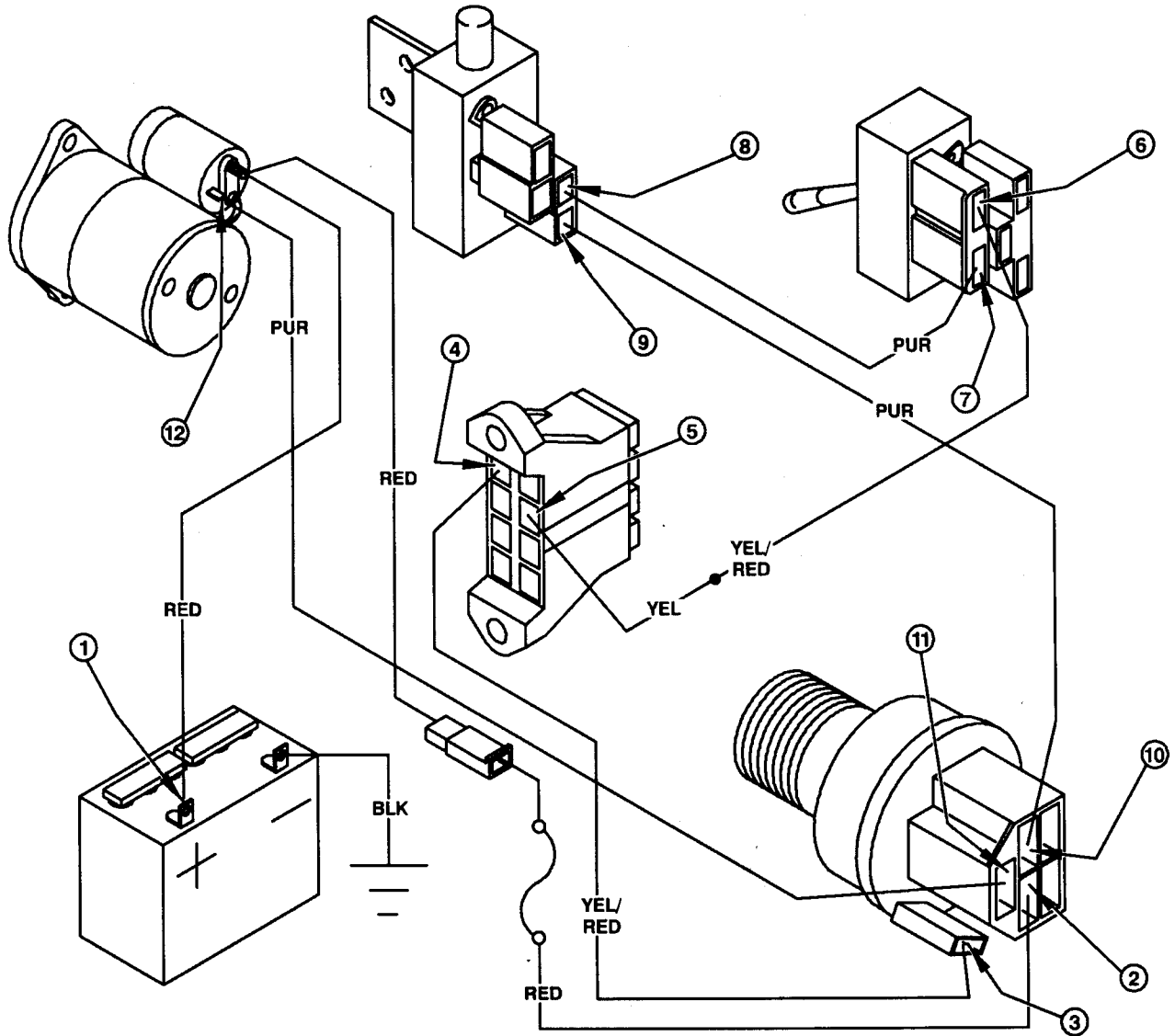

CRANKING CIRCUIT TEST POINTS
F510(-011957) AND F525(-012519)

M45959

MX,24015CL,A3 -19-23OCT95

240
15
5

M45959 -19-24JUN91

CRANKING CIRCUIT TEST POINTS—F510 (011958—) AND F525 (012520—)

Conditions:

- Transmission in neutral
- Park brake engaged
- PTO disengaged
- Ignition switch in RUN position
- Meter negative (—) lead on battery negative (—) terminal
- Meter positive (+) lead on numbered test point

Test Location	Normal	If Not Normal
1. Battery positive (+) terminal	11.8—13.2 volts	Test battery.
2. Ignition switch terminal B	Battery voltage	Check battery cable connection, starter tie point, harness connector, fusible link, and red wire.
3. Ignition switch terminal A	Battery voltage	Test ignition switch.
4. 20 amp fuse (hot side)	Battery voltage	Check yel/red wire and connectors.
5. 20 amp fuse (protected side)	Battery voltage	Check fuse.
6. PTO switch	Battery voltage	Check yel and yel/red wires.
7. PTO switch	Battery voltage	Test PTO switch.
8. Brake switch	Battery voltage	Check pur wire.
9. Brake switch	Battery voltage	Test brake switch.
10. Ignition relay terminal 87	Battery voltage	Check purple wire.
11. Ignition relay terminal 86	Battery voltage	Check diode wire*.
12. Ignition relay terminal 85	Greater than 0- less than 0.2 volts	Greater than 0.2 volts-check ignition and PTO relay ground circuit. 0 volts-test ignition relay.
13. Ignition relay terminal 30	Battery voltage	Test ignition relay.
14. Ignition switch terminal S1	Battery voltage	Check pur/blk wire.
Conditions:		
• Ignition switch in start position		
15. Ignition switch terminal S2	Battery voltage	Test ignition switch.
16. Starter solenoid terminal	Battery voltage	Check pur wire. Battery voltage - test starter solenoid and motor.

* On later harnesses with plug-in diodes, wire color may be purple or purple/white.

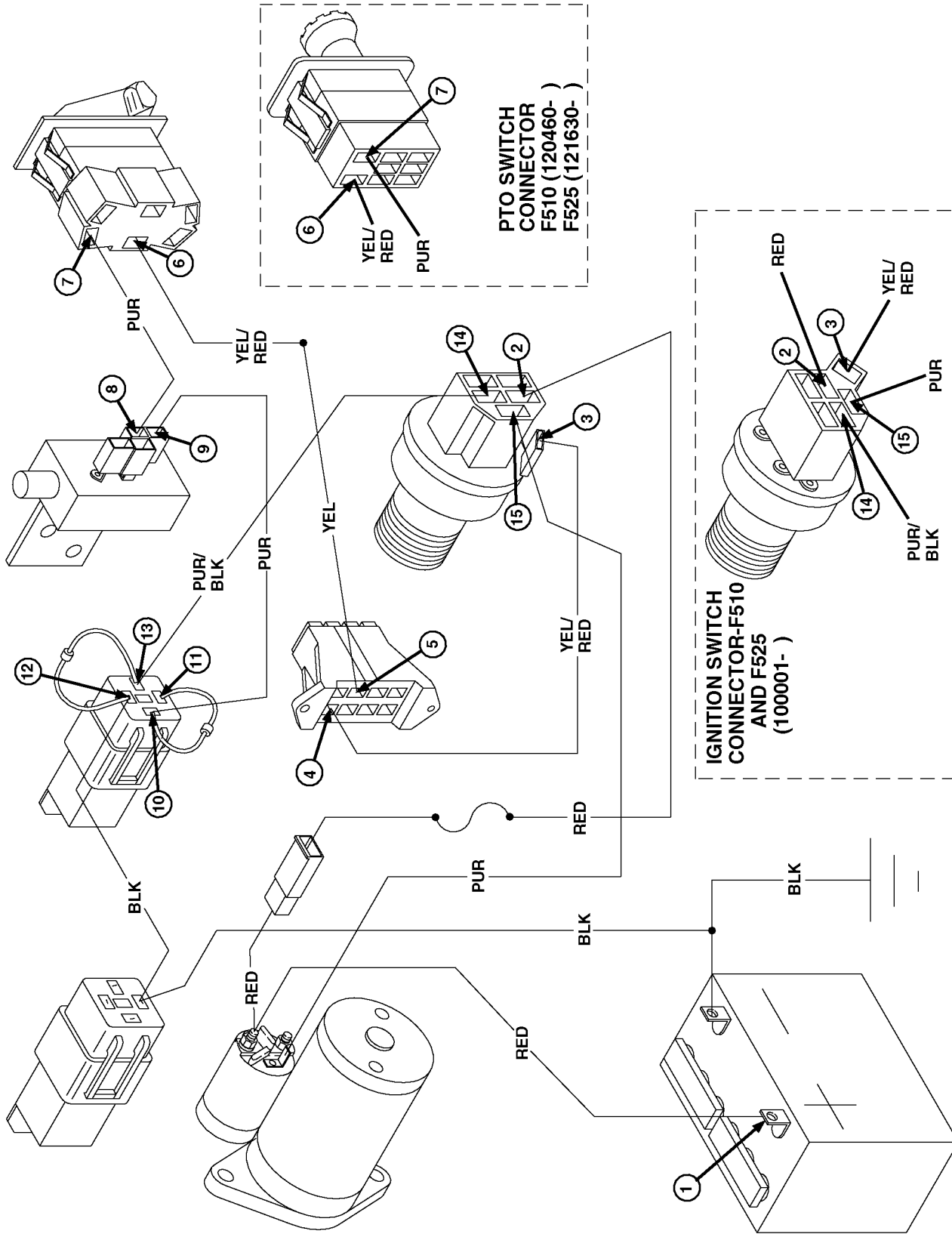

CRANKING CIRCUIT TEST POINTS - F510(011958-) AND F525(012520-)

M45960

-19-15MAY95

240
15
7

IGNITION POWER CIRCUIT TEST POINTS—OPERATOR ON SEAT

When diagnosing an ignition problem, isolate the magneto circuit from the power and ground circuit by separating the engine connector (white wire). Check for spark using D05351ST Spark Tester. If no spark, check the magneto circuit. If spark is present, check the ground and power circuit. If the engine will not shut off, check the ground circuit. Remember the engine is stopped by grounding the ignition coil through either the key switch or the ignition relay. The ignition relay must be energized to prevent the ignition coil from being grounded.

Conditions:

- Transmission in neutral
- Park brake engaged
- PTO disengaged
- Operator on seat
- Ignition switch in RUN position
- Meter negative (—) lead on battery negative (—) terminal
- Meter positive (+) lead on numbered test point

Test Location	Normal	If Not Normal
1. Battery positive (+) terminal	11.8—13.2 volts	Test battery.
2. Ignition switch terminal B	Battery voltage	Check battery cable connection, starter tie point, harness connector, fusible link, and red wire to switch.
3. Ignition switch terminal A	Battery voltage	Test ignition switch.
4. 15 amp fuse	Battery voltage	Check yel/red wire.
5. 15 amp fuse	Battery voltage	Check fuse.
6. Seat switch	Battery voltage	Check yel wire.
7. Seat switch	Battery voltage	Test switch.
8. Ignition relay terminal 86	Battery voltage	Check pnk wire.
9. Ignition relay terminal 85	Greater than 0 - less than 0.2 volts	0 volts-test ignition relay. Greater than 0.2 volts-test ignition and PTO relay ground circuit.

MX,24015CL,A4 -19-23OCT95

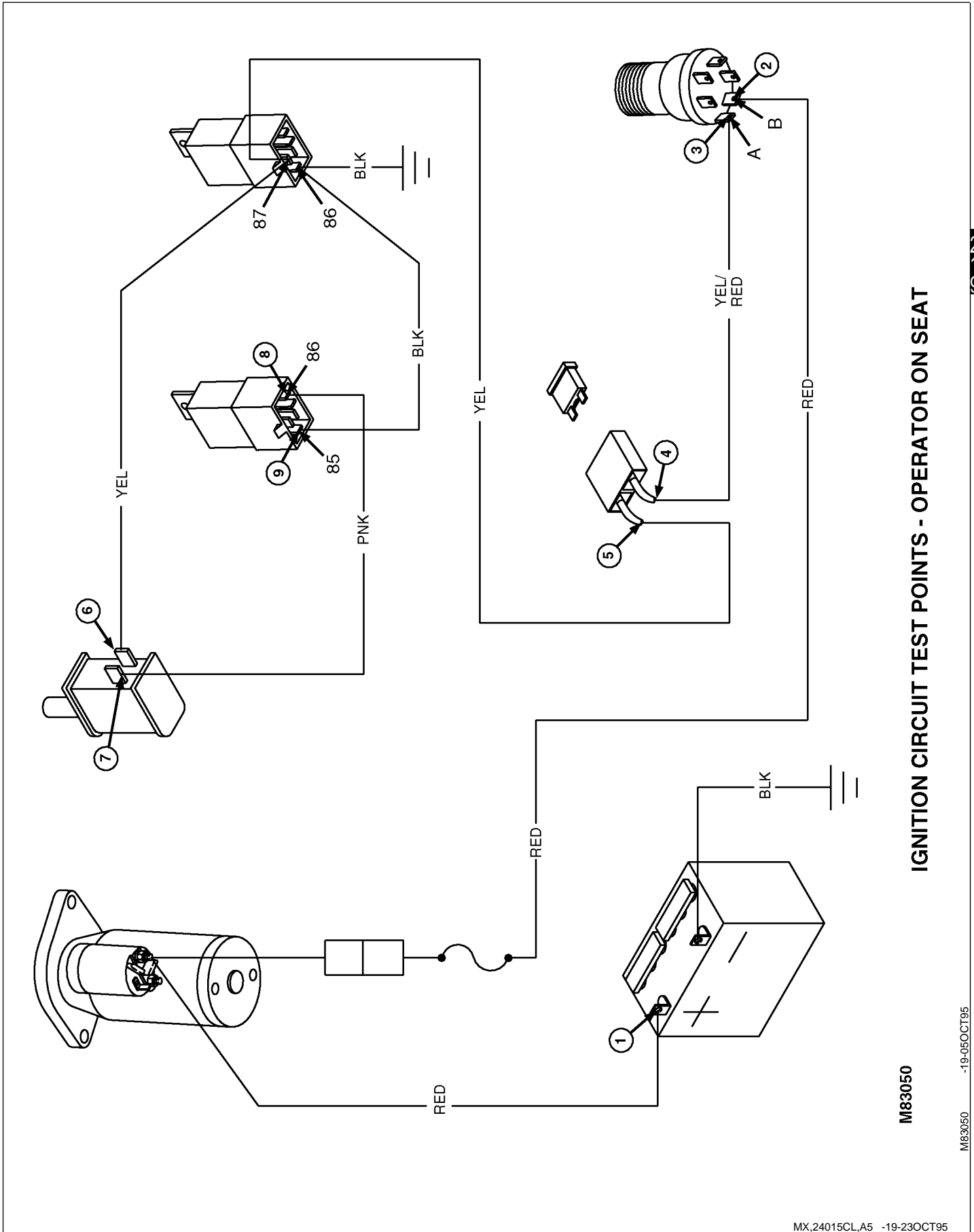

IGNITION CIRCUIT TEST POINTS - OPERATOR ON SEAT

M83050

M83050 -19-05OCT95

240
15
9

IGNITION POWER CIRCUIT TEST POINTS—OFF SEAT—F510 (—011957) AND F525 (—012519)

When diagnosing an ignition problem, isolate the magneto circuit from the power and ground circuit by separating the engine connector (white wire). Check for spark using D05351ST Spark Tester. If no spark, check the magneto circuit. If spark is present, check the ground and power circuit. If the engine will not shut off, check the ground circuit. Remember the engine is stopped by grounding the ignition coil through either the key switch or the ignition relay. The ignition relay must be energized to prevent the ignition coil from being grounded.

Conditions:

- Transmission in neutral
- Park brake engaged
- PTO disengaged
- Operator OFF seat
- Ignition switch in RUN position
- Meter negative (—) lead on battery negative (—) terminal
- Meter positive (+) lead on numbered test point

Test Location	Normal	If Not Normal
1. Battery positive (+) terminal	11.8—13.2 volts	Test battery.
2. Ignition switch terminal B	Battery voltage	Check battery cable connection, starter tie point, harness connector, fusible link, and red wire to ignition switch.
3. Ignition switch terminal A	Battery voltage	Test ignition switch.
4. 20 amp fuse	Battery voltage	Check yel/red wire.
5. 20 amp fuse	Battery voltage	Check fuse.
6. PTO switch	Battery voltage	Check yel and yel/red wires.
7. PTO switch	Battery voltage	Test PTO switch.
8. Brake switch	Battery voltage	Check pur wire.
9. Brake switch	Battery voltage	Test brake switch.
10. Ignition relay terminal 86	Battery voltage	Check pur and pur/blk wire.
11. Ignition relay terminal 85	Greater than 0 - less than 0.2 volts	0 volts-test ignition relay. Greater than 0.2 volts-check ignition and PTO relay ground circuit.

240
15
10

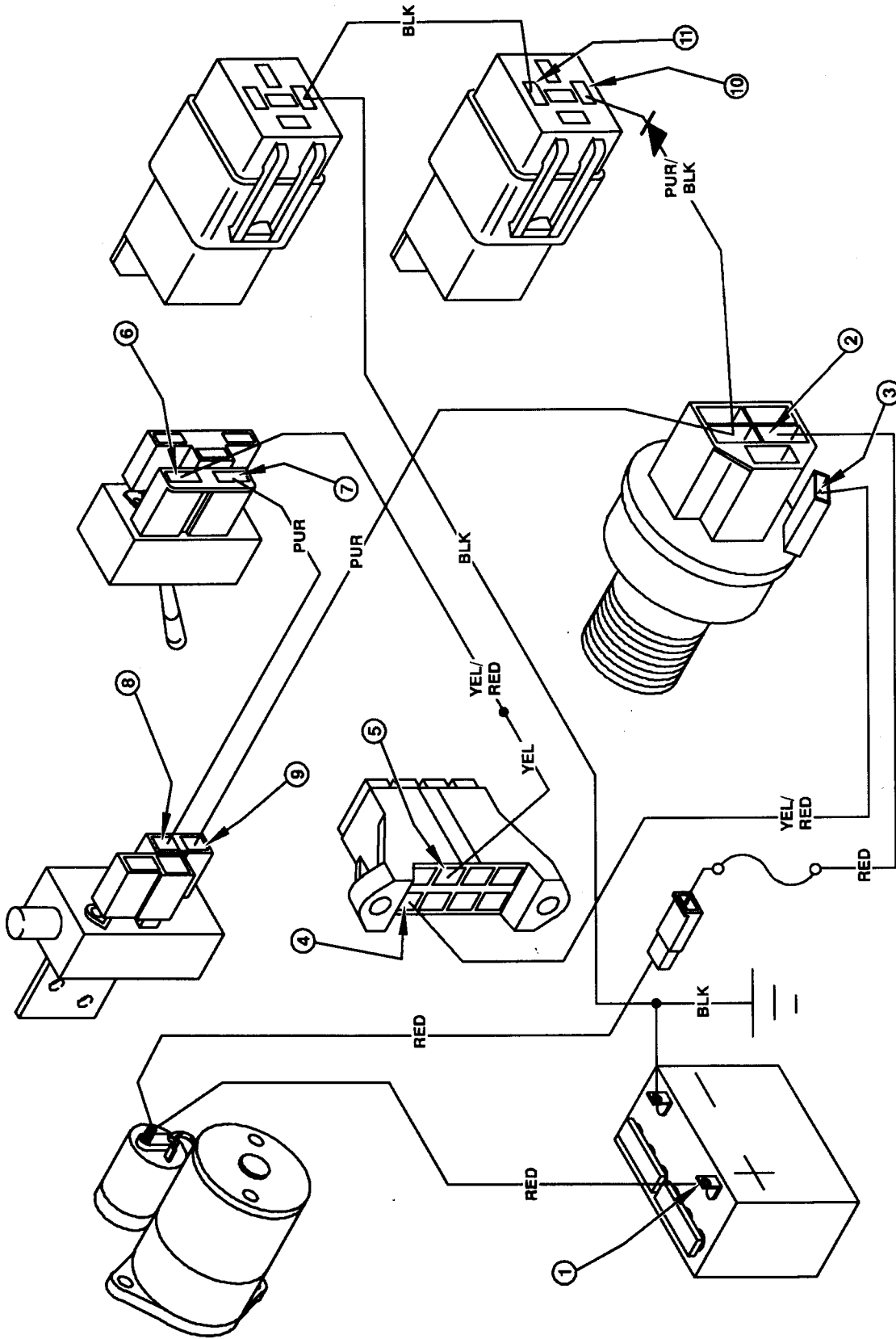

**IGNITION POWER CIRCUIT TEST POINTS - OFF SEAT
F510(-011957) AND F525(-012519)**

M45961

240
15
11

M45961
-19-24/JUN/91

MX.24015CL.A7 -19-23OCT95

IGNITION POWER CIRCUIT TEST POINTS—OFF SEAT—F510 (011958—) AND F525 (012520—)

When diagnosing an ignition problem, isolate the magneto circuit from the power and ground circuit by separating the engine connector (white wire). Check for spark using D05351ST Spark Tester. If no spark, check the magneto circuit. If spark is present, check the ground and power circuit. If the engine will not shut off, check the ground circuit. Remember the engine is stopped by grounding the ignition coil through either the key switch or the ignition relay. The ignition relay must be energized to prevent the ignition coil from being grounded.

Conditions:

- Transmission in neutral
- Park brake engaged
- PTO disengaged
- Operator OFF seat
- Ignition switch in RUN position
- Meter negative (—) lead on battery negative (—) terminal
- Meter positive (+) lead on numbered test point

Test Location	Normal	If Not Normal
1. Battery positive (+) terminal	11.8—13.2 volts	Test battery.
2. Ignition switch terminal B	Battery voltage	Check battery cable connection, starter tie point, harness connector, fusible link, and red wire to ignition switch.
3. Ignition switch terminal A	Battery voltage	Test ignition switch.
4. 20 amp fuse	Battery voltage	Check yel/red wire.
5. 20 amp fuse	Battery voltage	Check fuse.
6. PTO switch	Battery voltage	Check yel and yel/red wires.
7. PTO switch	Battery voltage	Test PTO switch.
8. Brake switch	Battery voltage	Check pur wire.
9. Brake switch	Battery voltage	Test brake switch.
10. Ignition relay terminal 87	Battery voltage	Check pur wire.
11. Ignition relay terminal 86	Battery voltage	Check diode wire*.
12. Ignition relay terminal 85	Greater than 0 - less than 0.2 volts	0 volts-test ignition relay. Greater than 0.2 volts-check ignition and PTO relay ground circuit.

* On later harnesses with plug-in diodes, wire color may be purple or purple/white.

240
15
12

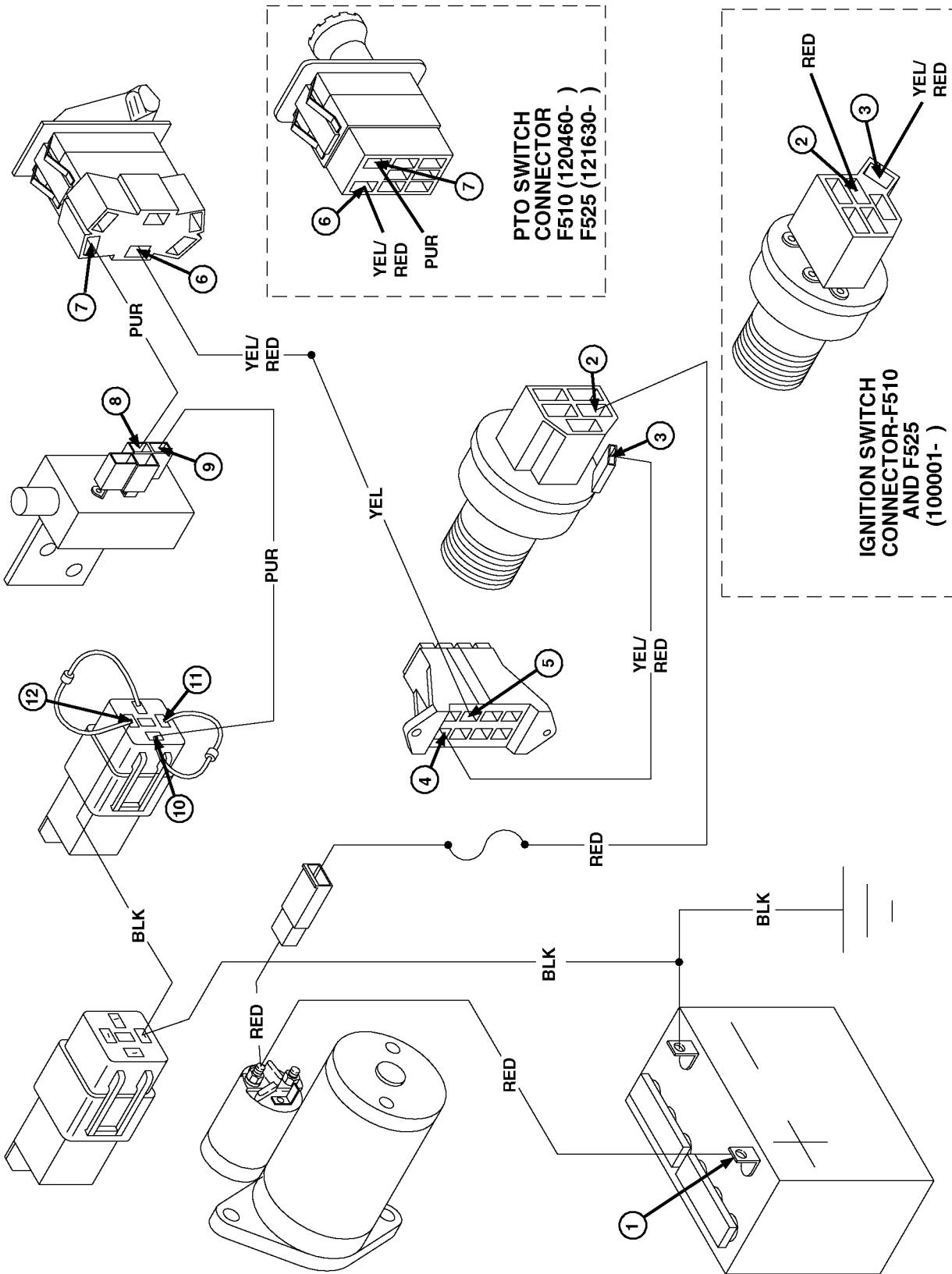

**IGNITION POWER CIRCUIT TEST POINTS - OFF SEAT
F510(011958-) AND F525(012520-)**

M45962

-19-15MAY95

M45962

240
15
13

MAGNETO AND GROUND CIRCUIT TEST POINTS—F510 (—011957) AND F525 (—012519)

When diagnosing an ignition problem, isolate the magneto circuit from the power and ground circuit by separating the engine connector (white wire). Check for spark using D05351ST Spark Tester. If no spark, check the magneto circuit. If spark is present, check the ground and power circuit. If the engine will not shut off, check the ground circuit. Remember the engine is stopped by grounding the ignition coil through either the key switch or the ignition relay. The ignition relay must be energized to prevent the ignition coil from being grounded.

Conditions:

- Park brake engaged
- Transmission in neutral
- PTO disengaged
- Engine connector (A) disconnected
- Spark plug lead connected to D05351ST Spark Tester
- Ignition switch in start position
- Meter negative (—) lead on engine ground
- Meter positive (+) lead on numbered test point

Test Location	Normal	If Not Normal
1. Spark tester	Spark test indicates hot blue spark	No spark - test ignition coil, check armature air gap, ignition module, ignition module ground screw, and flywheel magnets. Spark - check spark plug gap and condition or replace spark plug. If plug is good, continue testing ground circuit.
Conditions:		
• Engine connector (A) connected		
• Ignition switch in off position		
2 to 3. Battery negative (—) terminal to engine ground	Continuity	Check battery negative (—) cable.
3 to 4. Engine ground to ignition switch terminal G	Continuity	Check blk wire.
4 to 5. Ignition switch terminal G to ignition switch terminal M	Continuity	Check ignition switch.
5 to 6. Ignition switch terminal M to ignition relay terminal 87A	Continuity	Check wht/blk wire.
6 to 7. Ignition relay terminals 87A to 30	Continuity	Test ignition relay.
7 to 8. Ignition relay terminals 30 to 85	Continuity	Check blk wire.

Continued on next page

MX,24015CL,A7C -19-23OCT95

MAGNETO AND GROUND CIRCUIT TEST POINTS—F510 (—011957) AND F525 (—012519)-CONTINUED

When diagnosing an ignition problem, isolate the magneto circuit from the power and ground circuit by separating the engine connector (white wire). Check for spark using D05351ST Spark Tester. If no spark, check the magneto circuit. If spark is present, check the ground and power circuit. If the engine will not shut off, check the ground circuit. Remember the engine is stopped by grounding the ignition coil through either the key switch or the ignition relay. The ignition relay must be energized to prevent the ignition coil from being grounded.

Conditions:

- Park brake engaged
- Transmission in neutral
- PTO disengaged
- Engine connector (A) connected
- Spark plug lead connected to D05351ST Spark Tester
- Ignition switch in OFF position
- Meter negative (—) lead on engine ground
- Meter positive (+) lead on numbered test point

Test Location	Normal	If Not Normal
8 to 9. Ignition relay terminal 85 to PTO relay terminal 86	Continuity	Check blk wire.
9 to 3. PTO relay terminal 86 to engine ground	Continuity	Check blk wire.
10 to 5. Engine connector to ignition switch terminal M	Continuity	Check wht wire.
10 to 11. Engine connector to ignition module	continuity	Check wht wire.

MX,24015CL,A7E -19-23OCT95

240
15
16

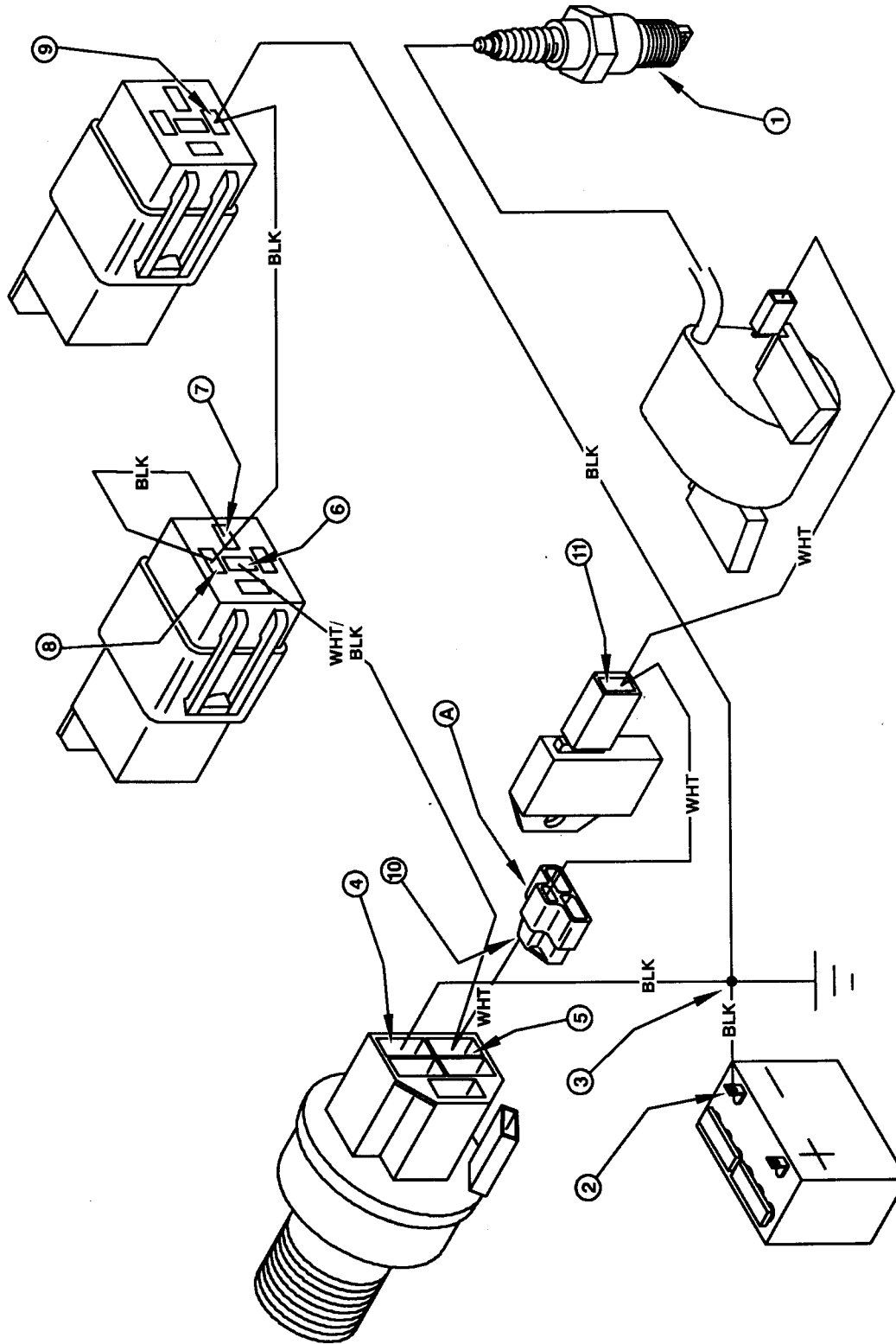

MAGNETO AND GROUND CIRCUIT TEST POINTS
F510(-011957) AND F525(-012519)

M45963

240
15
17

M45963
-19-24JUN91

MX,24015CL,A7D -19-23OCT95

MAGNETO AND GROUND CIRCUIT TEST POINTS—F510 (011958—) AND F525 (012520—)

When diagnosing an ignition problem, isolate the magneto circuit from the power and ground circuit by separating the engine connector (white wire). Check for spark using D05351ST Spark Tester. If no spark, check the magneto circuit. If spark is present, check the ground and power circuit. If the engine will not shut off, check the ground circuit. Remember the engine is stopped by grounding the ignition coil through either the key switch or the ignition relay. The ignition relay must be energized to prevent the ignition coil from being grounded.

Conditions:

- Park brake engaged
- Transmission in neutral
- PTO disengaged
- Engine connector (A) disconnected
- Spark plug lead connected to D05351ST Spark Tester
- Ignition switch in start position
- Meter negative (—) lead on engine ground
- Meter positive (+) lead on numbered test point

Test Location	Normal	If Not Normal
1. Spark tester	Spark test indicates hot blue spark	No spark - test ignition coil, check armature air gap, ignition module, ignition module ground screw, and flywheel magnets. Spark - check spark plug gap and condition or replace spark plug. If plug is good, continue testing ground circuit.
Conditions:		
<ul style="list-style-type: none"> • Engine connector (A) connected • Ignition switch in off position 		
2 to 3. Battery negative (—) terminal to engine ground	Continuity	Check battery negative (—) cable.
3 to 4. Engine ground to ignition switch terminal G	Continuity	Check blk wire.
4 to 5. Ignition switch terminal G to ignition switch terminal M	Continuity	Check ignition switch.
5 to 6. Ignition switch terminal M to ignition relay terminal 87A	Continuity	Check wht/blk wire.
6 to 7. Ignition relay terminals 87A to 30	Continuity	Test ignition relay.
7 to 8. Ignition relay terminals 30 to 85 - reverse meter leads and check again	Continuity one way only	No continuity - check blk wire Continuity both ways - replace diode*.

* On later harnesses with plug-in diodes, wire color may be purple or purple/white.

**MAGNETO AND GROUND CIRCUIT TEST POINTS
F510(011958-) AND F525(012520-)**

M45964

M45964
-19-24JUN91

MX,24015CL,A7G -19-23OCT95

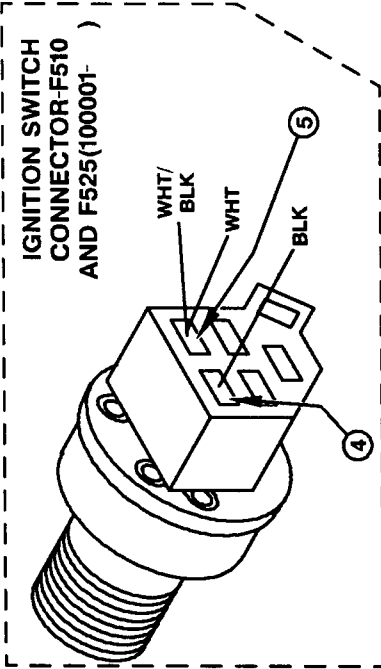
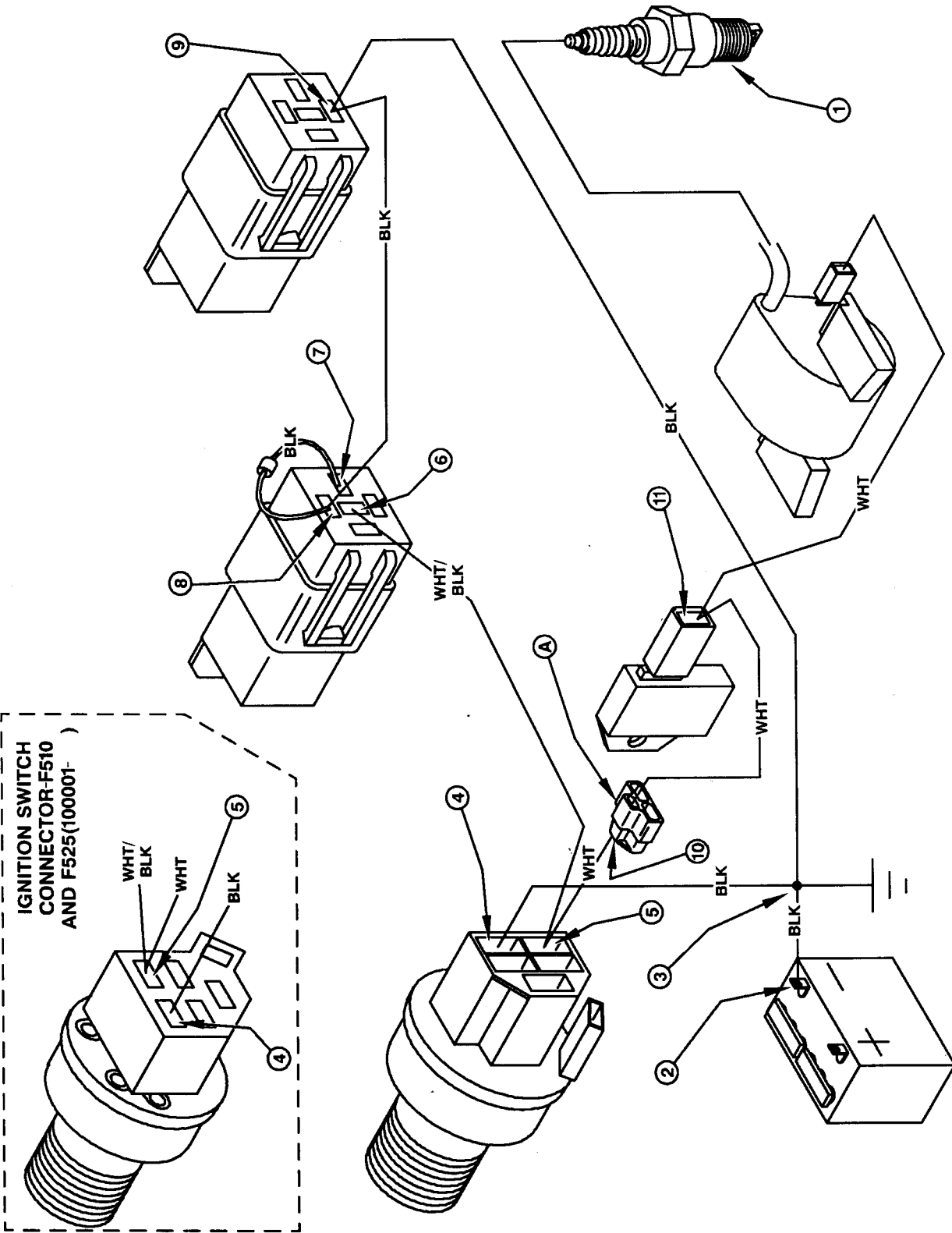

MAGNETO AND GROUND CIRCUIT TEST POINTS—F510 (011958—) AND F525 (012520—)-CONTINUED

When diagnosing an ignition problem, isolate the magneto circuit from the power and ground circuit by separating the engine connector (white wire). Check for spark using D05351ST Spark Tester. If no spark, check the magneto circuit. If spark is present, check the ground and power circuit. If the engine will not shut off, check the ground circuit. Remember the engine is stopped by grounding the ignition coil through either the key switch or the ignition relay. The ignition relay must be energized to prevent the ignition coil from being grounded.

Conditions:

- Park brake engaged
- Transmission in neutral
- PTO disengaged
- Engine connector (A) connected
- Spark plug lead connected to D05351ST Spark Tester
- Ignition switch in OFF position
- Meter negative (—) lead on engine ground
- Meter positive (+) lead on numbered test point

Test Location	Normal	If Not Normal
8 to 9. Ignition relay terminal 85 to PTO relay terminal 86	Continuity	Check blk wire.
9 to 3. PTO relay terminal 86 to engine ground	Continuity	Check blk wire.
10 to 5. Engine connector to ignition switch terminal M	Continuity	Check wht wire.
10 to 11. Engine connector to ignition module	Continuity	Check wht wire.

MX,24015CL,A7H -19-23OCT95

240
15
20

**MAGNETO AND GROUND CIRCUIT TEST POINTS
F510(011958-) AND F525(012520-)**

M45964

M45964 -19-24JUN91

MX,24015CL,A7G -19-23OCT95

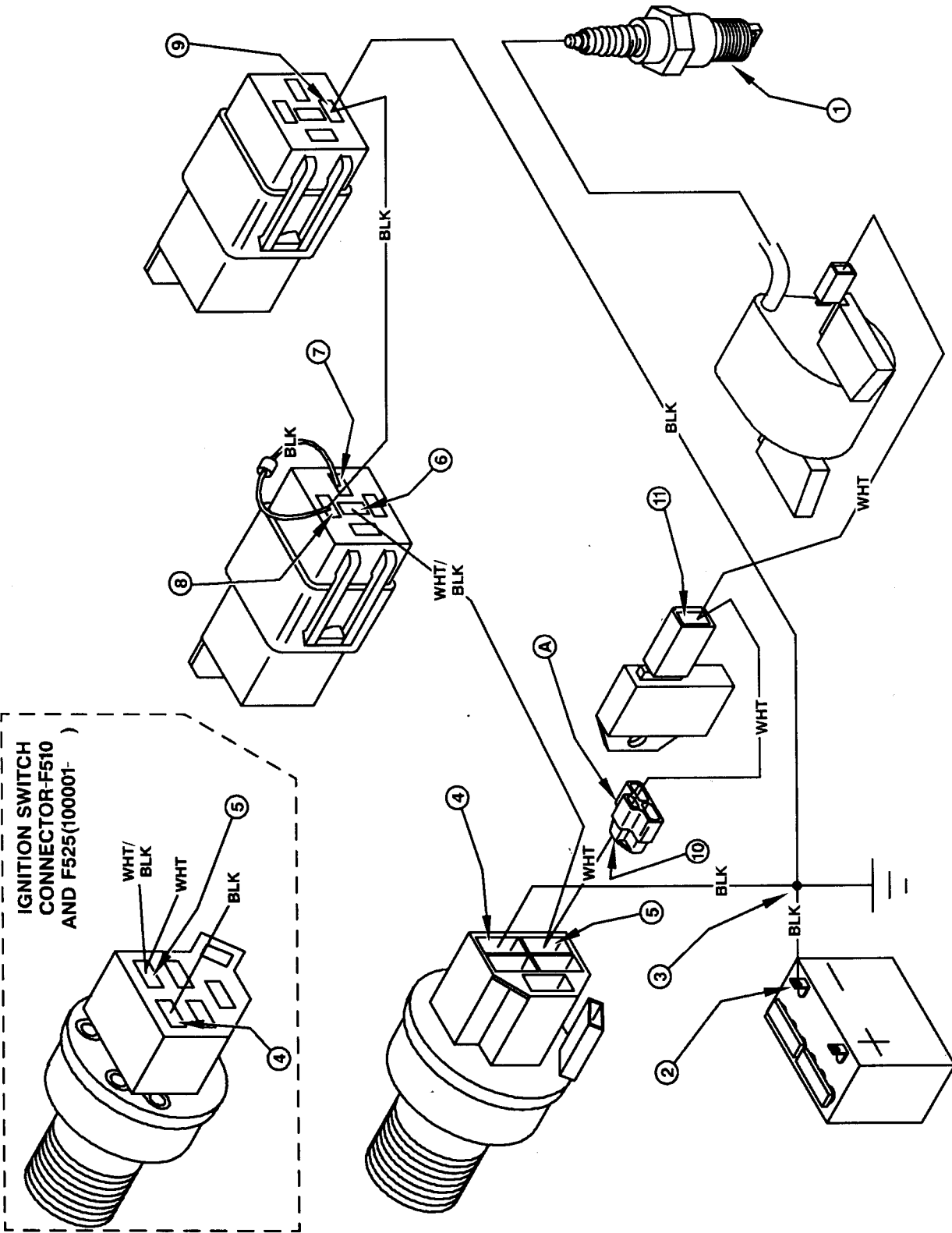

FUEL SHUT-OFF SOLENOID TEST POINTS

Conditions:

- Transmission in neutral
- Park brake engaged
- PTO disengaged
- Ignition switch in RUN position
- Meter negative (—) lead on battery negative (—) terminal
- Meter positive (+) lead on numbered test point

240
15
22

Test Location	Normal	If Not Normal
1. Battery positive (+) terminal	11.8—13.2 volts	Test battery.
2. Key switch terminal B	Battery voltage	Test red wire, fusible link, connector, starter tie points and battery connections.
3. Key switch terminal A	Battery voltage	Test key switch.
4. 20 amp fuse	Battery voltage	Test yel/red wire.
5. 20 amp fuse	Battery voltage	Test fuse, fuse holder.
6. Fuel shut-off solenoid	Battery voltage	Check yel and pnk/blk wires.
7. Fuel shut-off solenoid ground	Greater than 0 - less than 0.2 volts	Greater than 0.2 volts - check fuel shut-off solenoid black ground wire (between carburetor and engine block) and engine ground circuit. 0 volts - replace fuel shut-off solenoid.

MX,24015CL,A8 -19-23OCT95

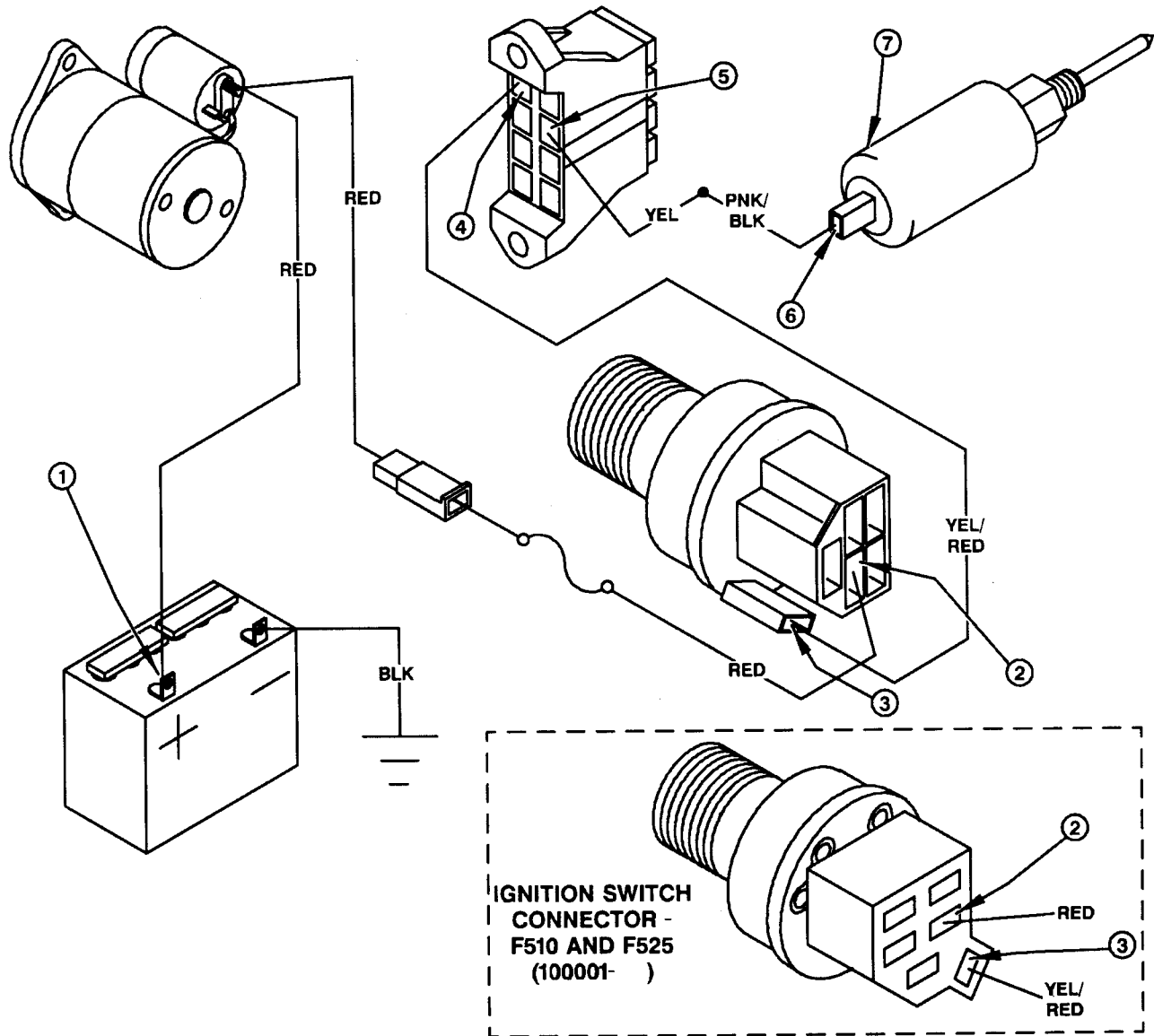

M45965

FUEL SHUT OFF SOLENOID CIRCUIT TEST POINTS

MX,24015CL,A9 -19-04MAY92

240
15
23

M45965 -19-24JUN91

PTO CIRCUIT TEST POINTS—F510 (—011957) AND F525 (—012519)

Conditions:

- Transmission in neutral
- Park brake engaged
- PTO disengaged
- Ignition switch in RUN position
- Meter negative (—) lead on battery negative (—) terminal
- Meter positive (+) lead on numbered test point

Test Location	Normal	If Not Normal
1. Battery positive (+) terminal	11.8—13.2 volts	Test battery.
2. Ignition switch terminal B	Battery voltage	Check battery cable connection, starter tie point, harness connector, fusible link, and red wire to switch.
3. Ignition switch terminal A	Battery voltage	Test ignition switch.
4. 20 amp fuse (Hot Side)	Battery voltage	Check yel/red wire.
5. 15 amp fuse	Battery voltage	Check fuse.
6. PTO relay terminal 87	Battery voltage	Check yel wire.
7. 20 amp fuse	Battery voltage	Check fuse.
8. PTO switch	Battery voltage	Check yel and yel/red wires.
9. PTO switch	Battery voltage	Test PTO switch.
10. Brake switch	Battery voltage	Check pur wire.
11. PTO relay terminal 85	Battery voltage	Check pur/wht wire, diode and diode wire.
12. PTO relay terminal 86	Greater than 0 - less than 0.2 volts	0 volts - test PTO relay coil. Greater than 0.2 volts - check PTO relay ground circuit.
13. PTO relay terminal 30	Battery voltage	Check PTO relay.
14. Brake switch	Battery voltage	Check blu wire.

240
15
24

Continued on next page

MX,24015CL,A10 -19-23OCT95

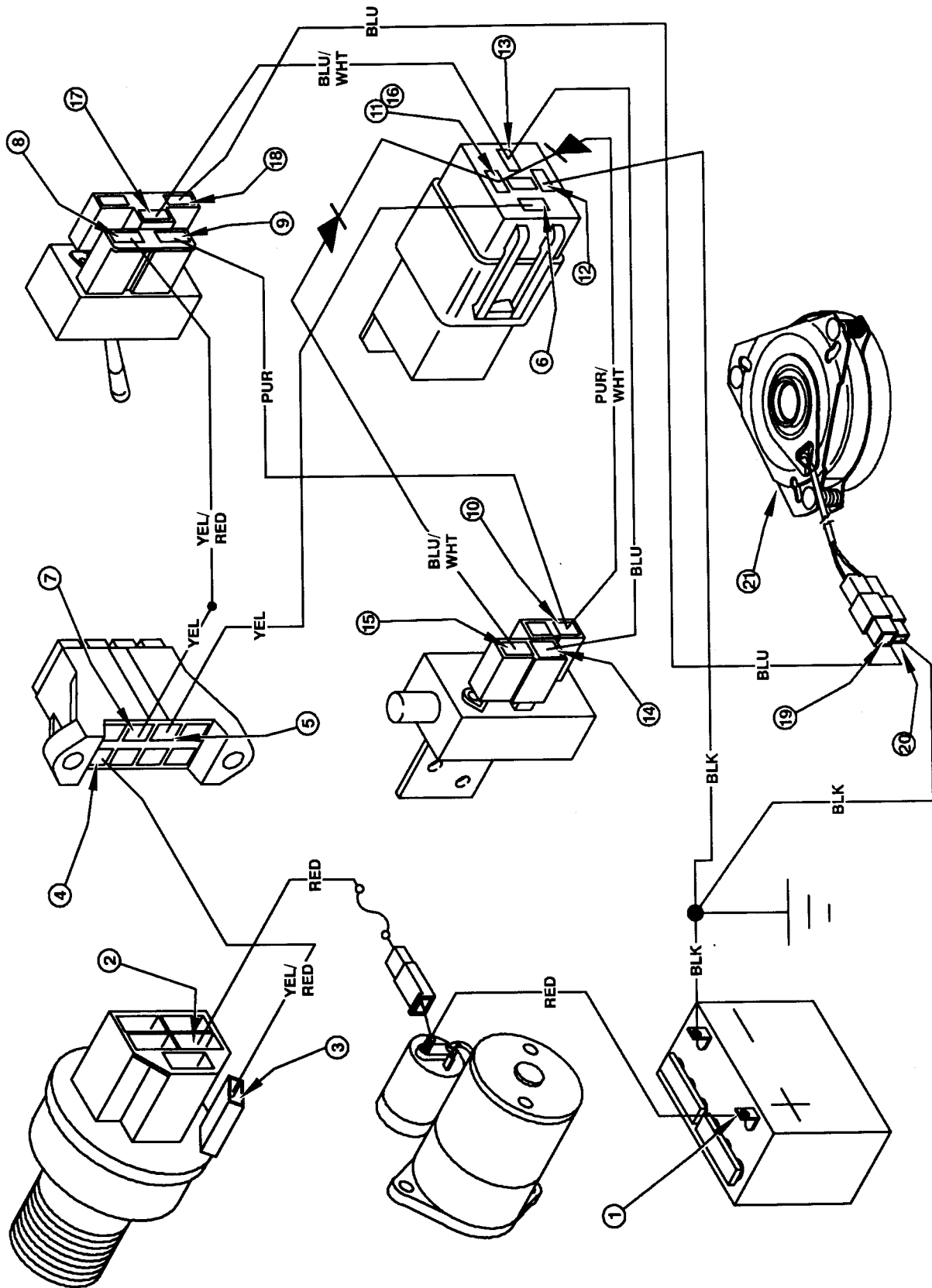

M45966 PTO CIRCUIT TEST POINTS - F510(-011957) AND F525(-012519)

240
15
25

M45966 -19-24JUN91

MX,24015CL,A11 -19-23OCT95

PTO CIRCUIT TEST POINTS—F510 (—011957) AND F525 (—012519)-CONTINUED

Conditions:

- Transmission in neutral
- Park brake DISENGAGED
- PTO ENGAGED
- Ignition switch in RUN position
- Meter negative (—) lead on battery negative (—) terminal
- Meter positive (+) lead on numbered test point

Test Location	Normal	If Not Normal
15. Brake switch	Battery voltage	Check brake switch.
16. PTO relay terminal 85	Battery voltage	Check blu/wht wire and diode.
17. PTO switch	Battery voltage	Check blu/wht wire.
18. PTO switch	Battery voltage	Check PTO switch.
19. PTO clutch	Battery voltage	Check blu wire.
20. PTO clutch	Greater than 0 - less than 0.2 volts	0 volts - test PTO clutch. Greater than 0.2 volts - check PTO clutch ground circuit.
21. PTO clutch	PTO clutch air gap- 0.38—0.64 mm (0.015—0.025 in.) Minimum PTO clutch current draw- 4 amps	Adjust air gap to 0.51 mm (0.020 in.). Replace PTO clutch.

MX,24015CL,A12 -19-23OCT95

240
15
26

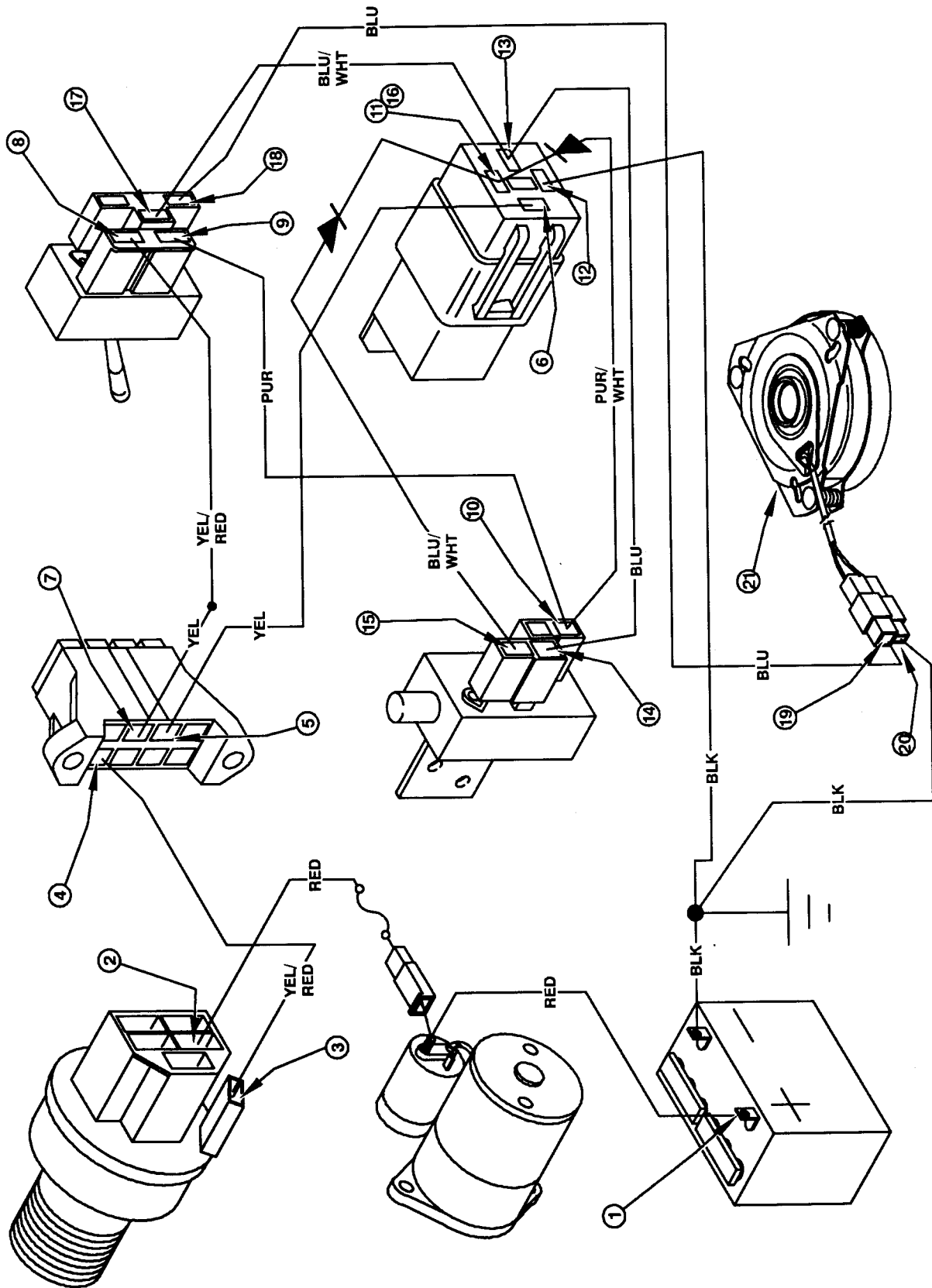

M45966 PTO CIRCUIT TEST POINTS - F510(-011957) AND F525(-012519)

240
15
27

M45966 -19-24JUN91

MX,24015CL,A11 -19-23OCT95

PTO CIRCUIT TEST POINTS—F510 (011958—) AND F525 (012520—)

Conditions:

- Transmission in neutral
- Park brake engaged
- PTO disengaged
- Ignition switch in RUN position
- Meter negative (—) lead on battery negative (—) terminal
- Meter positive (+) lead on numbered test point

Test Location	Normal	If Not Normal
1. Battery positive (+) terminal	11.8—13.2 volts	Test battery.
2. Ignition switch terminal B	Battery voltage	Check battery cable connection, starter tie point, harness connector, fusible link, and red wire to switch.
3. Ignition switch terminal A	Battery voltage	Test ignition switch.
4. 20 amp fuse (Hot Side)	Battery voltage	Check yel/red wire.
5. 15 amp fuse	Battery voltage	Check fuse.
6. PTO relay terminal 87	Battery voltage	Check yel wire.
7. 20 amp fuse	Battery voltage	Check fuse.
8. PTO switch	Battery voltage	Check yel and yel/red wires.
9. PTO switch	Battery voltage	Test PTO switch.
10. Brake switch	Battery voltage	Check pur wire.
11. PTO relay terminal 85	Battery voltage	Check pur/wht wire, diode and diode wire*.
12. PTO relay terminal 86	Greater than 0 - less than 0.2 volts	0 volts - test PTO relay coil. Greater than 0.2 volts - check PTO relay ground circuit.
13. PTO relay terminal 30	Battery voltage	Check PTO relay.
14. Brake switch	Battery voltage	Check blu wire.

* On later harnesses with plug-in diodes, wire color may be purple or purple/white.

Continued on next page

MX,24015CL,A13 -19-23OCT95

240
15
28

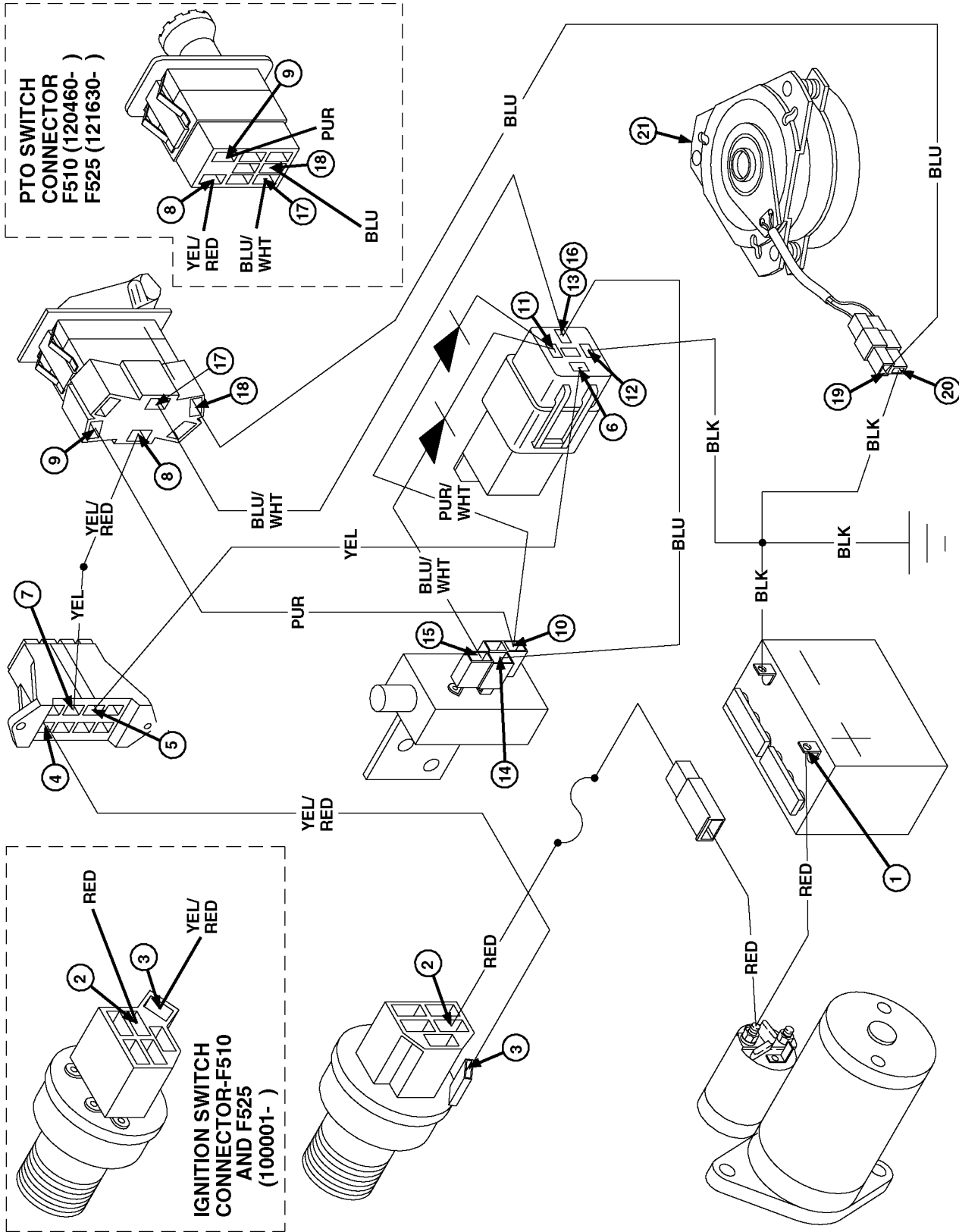

PTO CIRCUIT TEST POINTS - F510(011958-) AND F525(012520-)

M45967

M45967 -19-15MAY95

240
15
29

PTO CIRCUIT TEST POINTS—F510 (011958—) AND F525 (012520—)-CONTINUED

Conditions:

- Transmission in neutral
- Park brake DISENGAGED
- PTO ENGAGED
- Ignition switch in RUN position
- Meter negative (—) lead on battery negative (—) terminal
- Meter positive (+) lead on numbered test point

Test Location	Normal	If Not Normal
15. Brake switch	Battery voltage	Check brake switch.
16. PTO relay terminal 85	Battery voltage	Check blu/wht wire, diode and diode wire*.
17. PTO switch	Battery voltage	Check blu/wht wire.
18. PTO switch	Battery voltage	Check PTO switch.
19. PTO clutch	Battery voltage	Check blu wire.
20. PTO clutch	Greater than 0 - less than 0.2 volts	0 volts - test PTO clutch. Greater than 0.2 volts - check PTO clutch ground circuit.
21. PTO clutch	PTO clutch air gap- 0.38—0.64 mm (0.015—0.025 in.) Minimum PTO clutch current draw- 4 amps	Adjust air gap to 0.51 mm (0.020 in.). Replace PTO clutch.

* On later harnesses with plug-in diodes, wire color may be purple or purple/white.

240
15
30

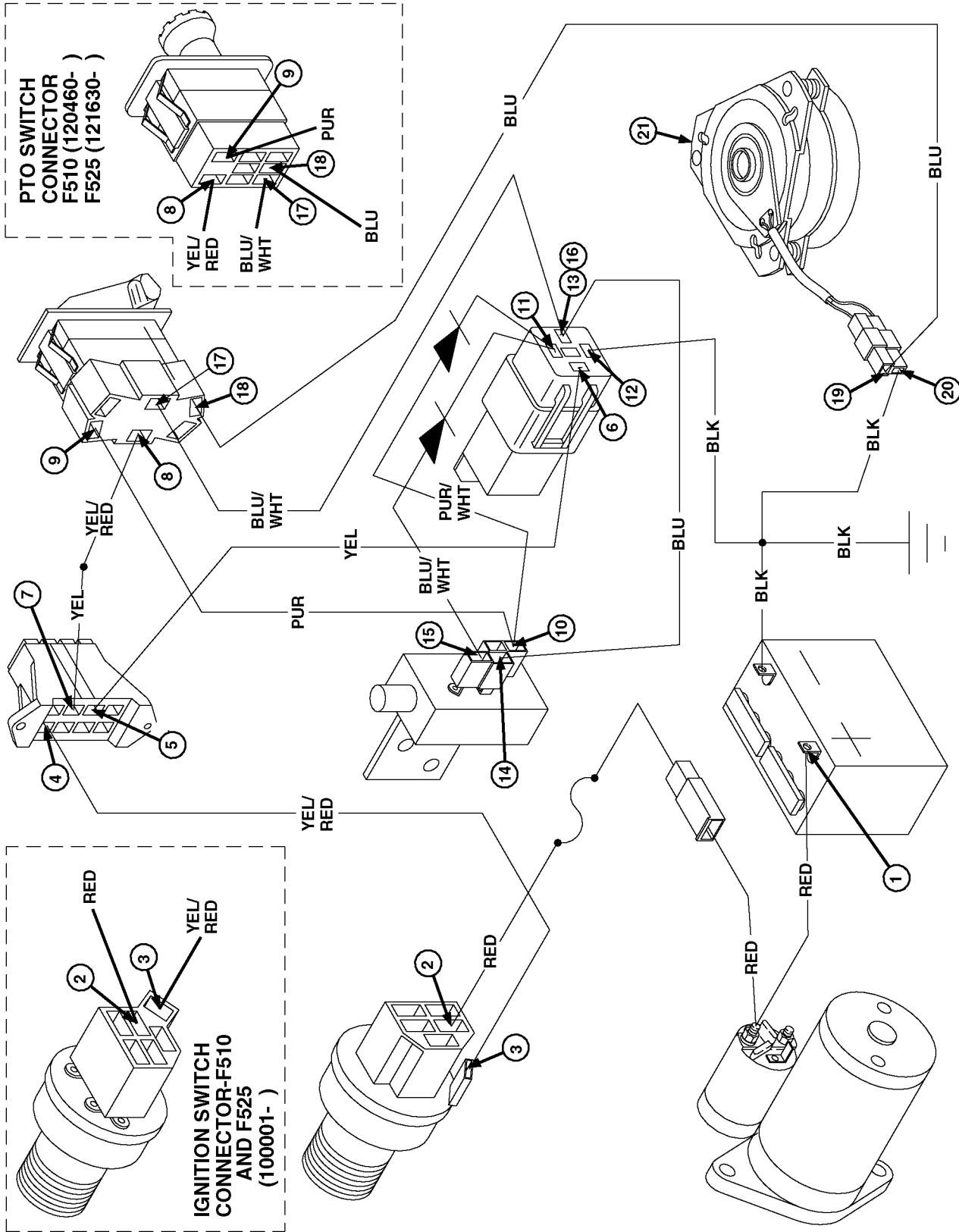

PTO CIRCUIT TEST POINTS - F510(011958-) AND F525(012520-)

M45967

M45967 -19-15MAY95

240
15
31

CHARGING AND DISCHARGE LIGHT CIRCUIT TEST POINTS

Conditions:

- Transmission in neutral
- Park brake engaged
- PTO disengaged
- Ignition switch in RUN position

- Meter negative (—) lead on battery negative (—) terminal
- Meter positive (+) lead on numbered test point
- Battery acid level 6 mm (0.25 in.) above plates
- Maximum voltage drop at test connections-0.2 volts

Test Location	Normal	If Not Normal
1. Battery positive (+) terminal	11.8—13.2 volts	Test battery.
2. Ignition switch terminal B	Battery voltage	Check starter connection, fusible link, and red wires.
3. Ignition switch terminal A	Battery voltage	Check ignition switch.
4. 30 amp fuse	Battery voltage	Check red wire.
5. 30 amp fuse	Battery voltage	Check fuse.
6. 20 amp fuse	Battery voltage	Check yel/red wire.
7. 20 amp fuse	Battery voltage	Check fuse.
8. Regulator/rectifier	Battery voltage	Check red wire.
9. Regulator/rectifier	Battery voltage	Check yel wires.
10. Regulator/rectifier	Greater than 0 - less than 0.2 volts	Greater than 0.2 volts - check regulator/rectifier ground circuit. 0 volts - replace regulator/rectifier.
11. Regulator/rectifier	Battery voltage	Replace regulator/rectifier.
12. Discharge light	Battery voltage	Check brown wire.
13. Discharge light	Greater than 0- less than 0.2 volts	Greater than 0.2 volts - check discharge light ground circuit. 0 volts - check bulb.

240
15
32

Continued on next page

MX,24015CL,A16 -19-23OCT95

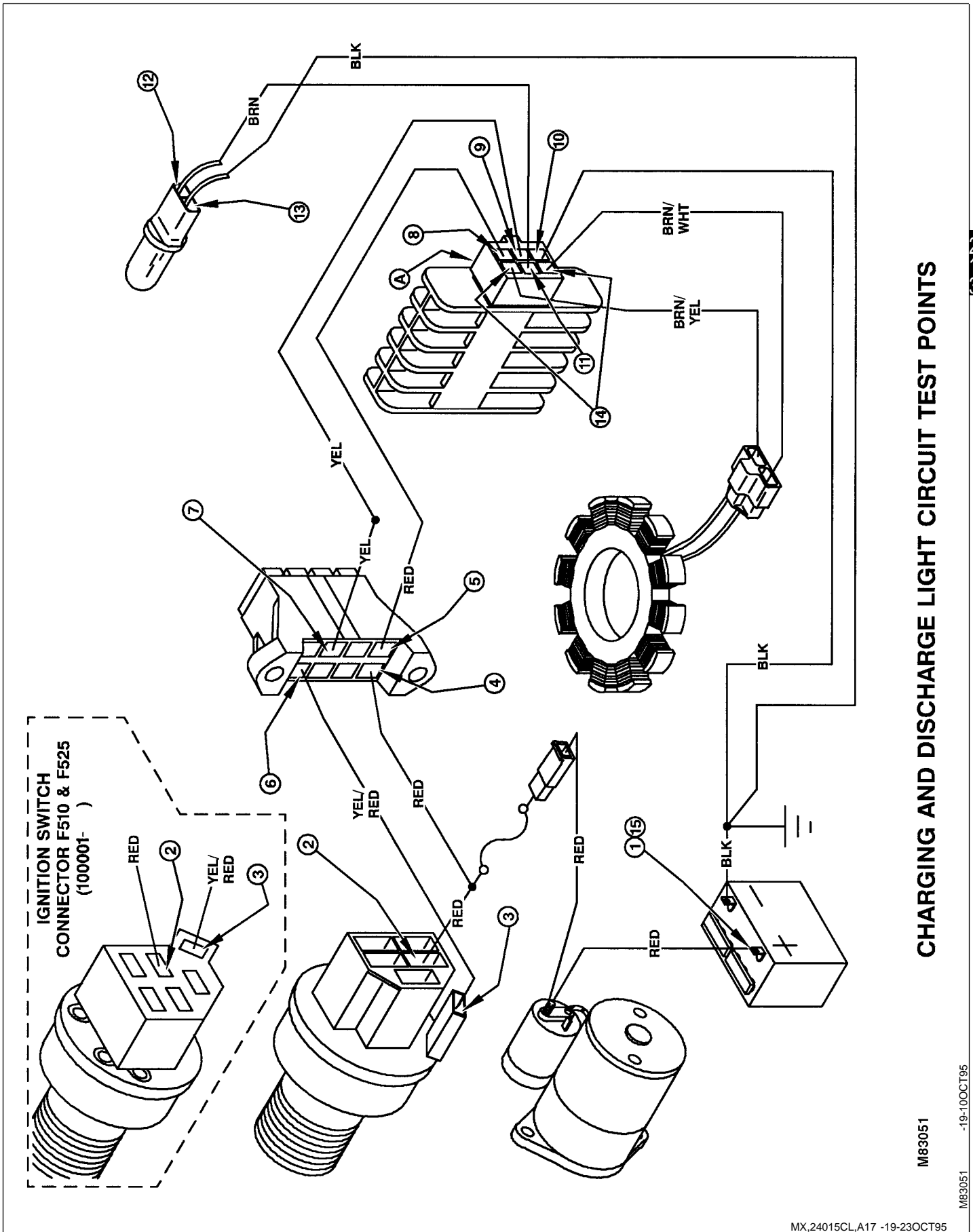

CHARGING AND DISCHARGE LIGHT CIRCUIT TEST POINTS

CHARGING AND DISCHARGE LIGHT CIRCUIT TEST POINTS-CONTINUED

Conditions:

- Transmission in neutral
- Park brake engaged
- PTO disengaged
- Ignition switch in RUN position
- Regulator/rectifier connector (A) disconnected
- Engine running at fast idle
- Meter leads in brn/yel and brn/wht wire terminals

Test Location	Normal	If Not Normal
14. Regulator/rectifier	Minimum unregulated voltage output: F510 (PA420A) - 30 VAC F525 (PA540A) - 27 VAC	Check for faulty stator. Check for weak flywheel magnets. Check brn/yel and brn/wht wires.
15. Battery positive (+) terminal	DC voltage rising to between 13 and 15 as engine runs for 5 min.	Replace regulator/rectifier.

MX,24015CL,A18 -19-23OCT95

240
15
34

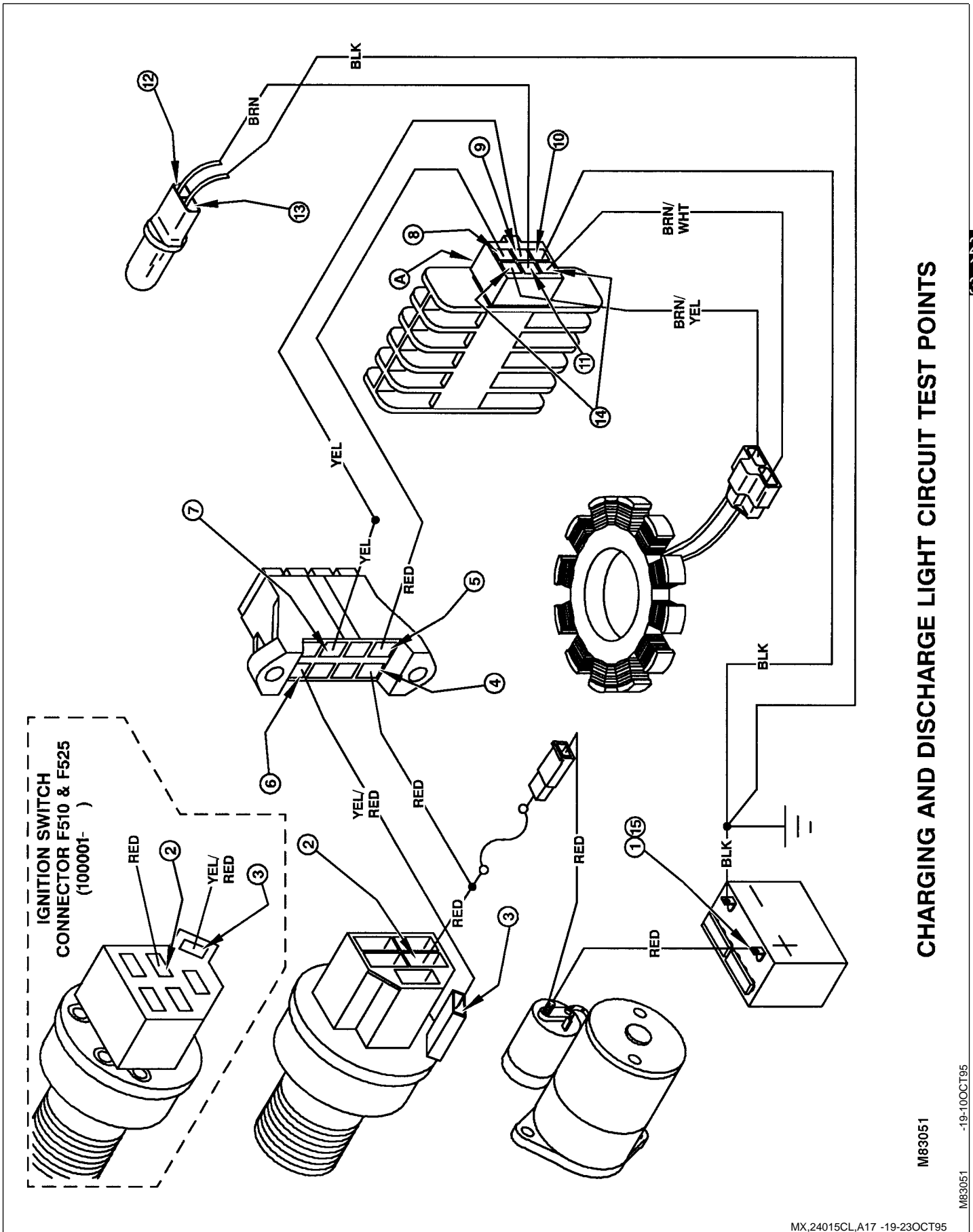

CHARGING AND DISCHARGE LIGHT CIRCUIT TEST POINTS

240
15
35

HOURMETER, LOW FUEL, AND OIL PRESSURE LIGHT CIRCUIT TEST POINTS—F510 (—011957) AND F525 (—012519)

Conditions:

- Transmission in neutral
- Park brake engaged
- PTO disengaged
- Low fuel sensor removed from fuel tank
- Ignition switch in RUN position
- Meter negative (—) lead on battery negative (—) terminal
- Meter positive (+) lead on numbered test point
- Maximum voltage drop at test connections-0.2 volts

Test Location	Normal	If Not Normal
1. Battery positive (+) terminal	11.8—13.2 volts	Test battery.
2. Ignition switch terminal B	Battery voltage	Check battery cable connection, starter tie point, harness connector, fusible link, and red wire to switch.
3. Ignition switch terminal A	Battery voltage	Test ignition switch.
4. 20 amp fuse	Battery voltage	Check yel/red wire.
5. 20 amp fuse	Battery voltage	Check fuse and terminal bussbar.
6. Oil pressure light	Battery voltage	Check indicator socket and yel wire.
7. Oil pressure sensor	Greater than 0 - less than 0.2 volts	Greater than 0.2 volts - test oil pressure sensor. 0 volts-check bulb and tan wire.
8. Low fuel light	Battery voltage	Check yel wire.
9. Low fuel sensor-float at lowest position (switch closed)	Greater than 0 - less than 0.2 volts	Greater than 0.2 volts - test low fuel sensor and check ground circuit. 0 volts - check bulb and blk/wht wire.
10. Low fuel sensor-float at highest position (switch open)	Battery voltage	Replace low fuel sensor.
11. PTO switch	Battery voltage	Check yel and yel/red wires.
12. Hourmeter	Battery voltage	Check yel wire.
13. Hourmeter	Greater than 0 - less than 0.2 volts	0 volts - replace hourmeter. Greater than 0.2 volts-test hourmeter and ignition switch ground circuit.

240
15
36

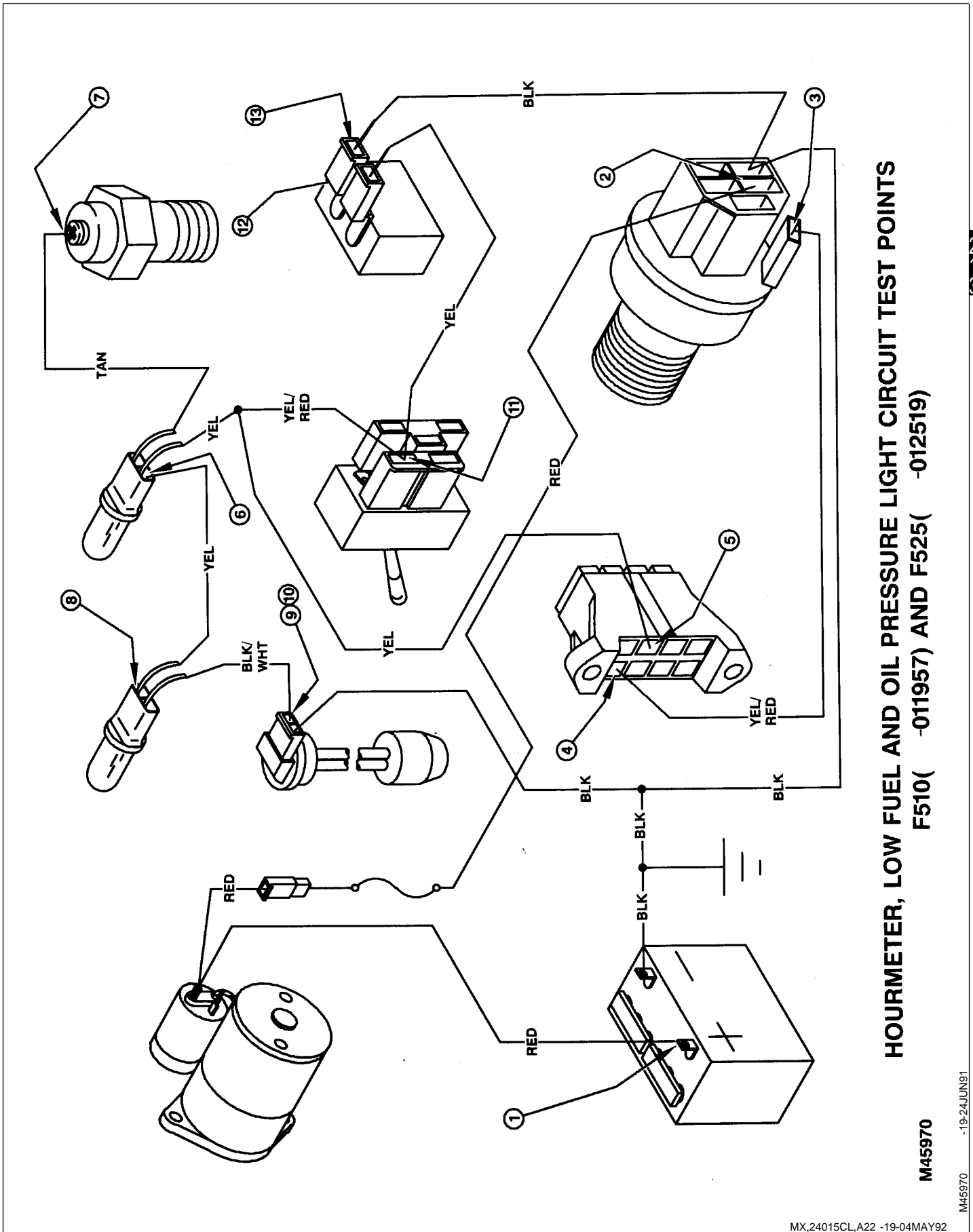

HOURMETER, LOW FUEL AND OIL PRESSURE LIGHT CIRCUIT TEST POINTS
F510(-011957) AND F525(-012519)

M45970

-19-24JUN91

240
15
37

HOURMETER, LOW FUEL, AND OIL PRESSURE LIGHT CIRCUIT TEST POINTS—F510 (011958—100000) AND F525 (012520—100000)

Conditions:

- Transmission in neutral
- Park brake engaged
- PTO disengaged
- Low fuel sensor removed from fuel tank
- Ignition switch in RUN position
- Meter negative (—) lead on battery negative (—) terminal
- Meter positive (+) lead on numbered test point
- Maximum voltage drop at test connections-0.2 volts

240
15
38

Test Location	Normal	If Not Normal
1. Battery positive (+) terminal	11.8—13.2 volts	Test battery.
2. Ignition switch terminal B	Battery voltage	Check battery cable connection, starter tie point, harness connector, fusible link, and red wire to switch.
3. Ignition switch terminal A	Battery voltage	Test ignition switch.
4. 20 amp fuse	Battery voltage	Check yel/red wire.
5. 20 amp fuse	Battery voltage	Check fuse and terminal bussbar.
6. Oil pressure light	Battery voltage	Check indicator socket and yel wire.
7. Oil pressure sensor	Greater than 0 - less than 0.2 volts	Greater than 0.2 volts - test oil pressure sensor. 0 volts-check bulb and tan wire.
8. Low fuel light	Battery voltage	Check yel wire.
9. Low fuel sensor-float at lowest position (switch closed)	Greater than 0 - less than 0.2 volts	Greater than 0.2 volts-test low fuel sensor and check ground circuit. 0 volts - check bulb and blk/wht wire.
10. Low fuel sensor-float at highest position (switch open)	Battery voltage	Replace low fuel sensor.
11. PTO switch	Battery voltage	Check yel and yel/red wires.
12. Hourmeter	Battery voltage	Check yel wire.
13. Hourmeter	Greater than 0 - less than 0.2 volts	0 volts - replace hourmeter. Greater than 0.2 volts - test hourmeter and ignition switch ground circuit.

MX,24015CL,A23 -19-23OCT95

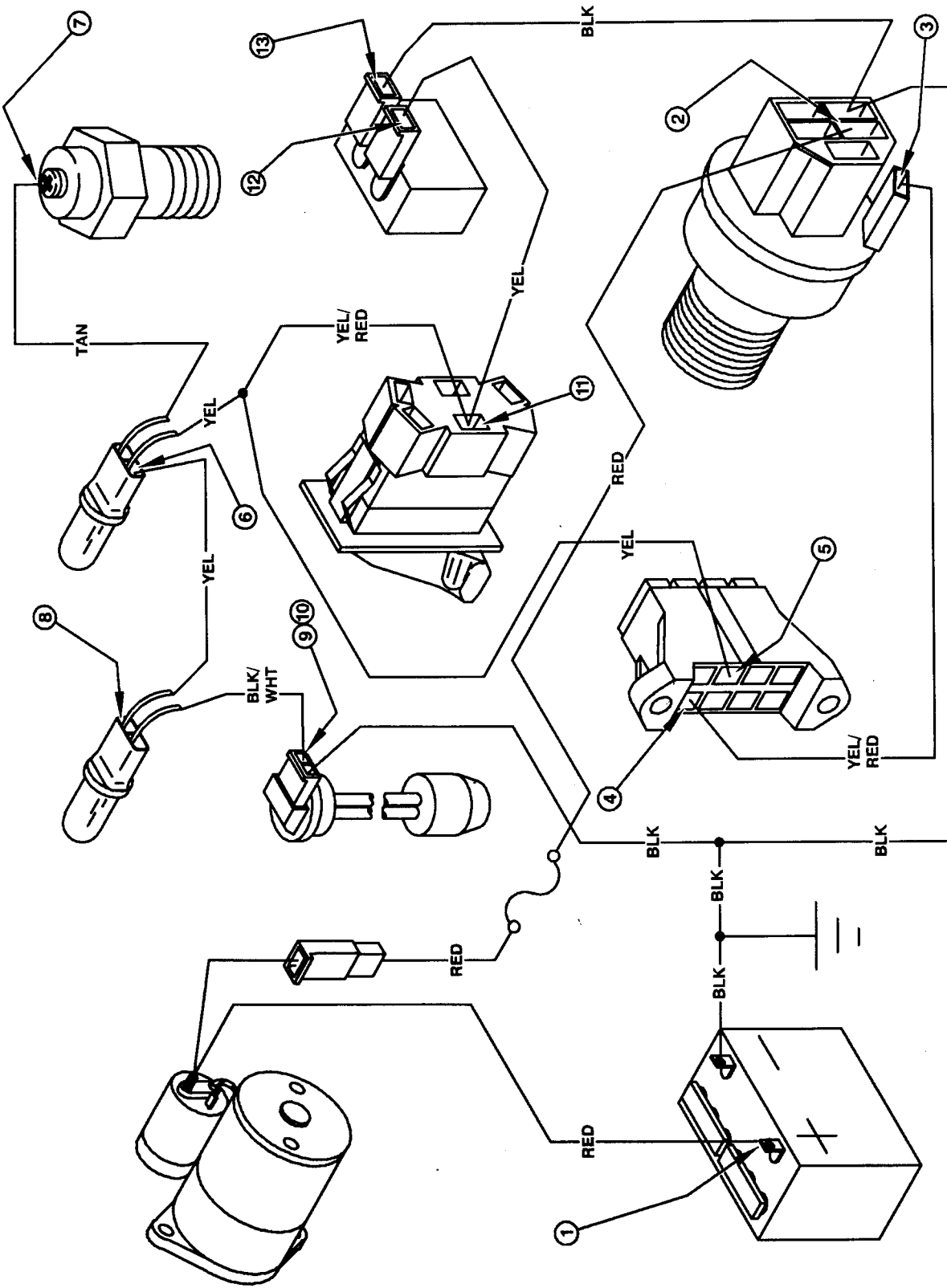

**HOURMETER, LOW FUEL AND OIL PRESSURE LIGHT CIRCUIT TEST POINTS
F510 (011958-100000) AND F525 (012520-100000)**

M45971

-19-24JUN91

240
15
39

MX,24015CL,A24 -19-23OCT95

HOURMETER, LOW FUEL, AND OIL PRESSURE LIGHT CIRCUIT TEST POINTS—F510 (100001—) AND F525 (100001—)

Conditions:

- Transmission in neutral
- Park brake engaged
- PTO disengaged
- Low fuel sensor removed from fuel tank
- Ignition switch in RUN position
- Meter negative (—) lead on battery negative (—) terminal
- Meter positive (+) lead on numbered test point
- Maximum voltage drop at test connections-0.2 volts

Test Location	Normal	If Not Normal
1. Battery positive terminal	11.8—13.2 volts	Test battery.
2. Ignition switch terminal B	Battery voltage	Check battery cable connection, starter tie point, harness connector, fusible link, and red wire to switch.
3. Ignition switch terminal A	Battery voltage	Test ignition switch.
4. 20 amp fuse	Battery voltage	Check yel/red wire.
5. 20 amp fuse	Battery voltage	Check fuse and terminal bussbar.
6. Oil pressure light	Battery voltage	Check indicator socket and yel wire.
7. Oil pressure sensor	Greater than 0 - less than 0.2 volts	Greater than 0.2 volts - test oil pressure sensor. 0 volts-check bulb and tan wire.
8. Low fuel light	Battery voltage	Check bulb and yel wire.
9. Low fuel sensor-float at lowest position (switch closed)	Greater than 0 - less than 0.2 volts	Greater than 0.2 volts - test low fuel sensor and check ground circuit. 0 volts - check bulb and blk/wht wire.
10. Low fuel sensor-float at highest position (switch open)	Battery voltage	Replace low fuel sensor.
11. PTO switch	Battery voltage	Check yel and yel/red wires.
12. Hourmeter	Battery voltage	Check yel wire.
13. Hourmeter	Greater than 0 - less than 0.2 volts	0 volts - replace hourmeter. Greater than 0.2 volts - test hourmeter and ignition switch ground circuit.

MX,24015CL,A25 -19-23OCT95

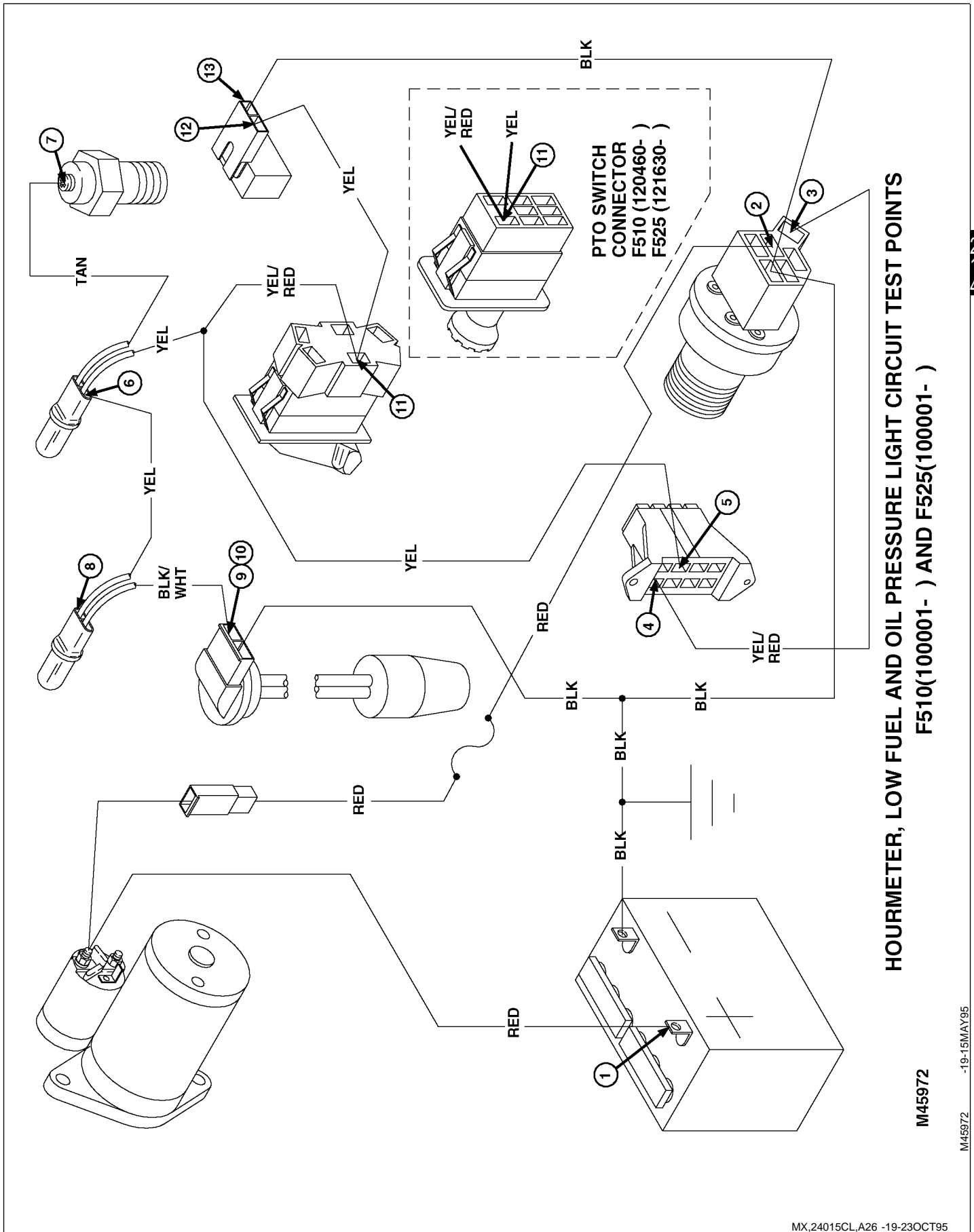

**HOURMETER, LOW FUEL AND OIL PRESSURE LIGHT CIRCUIT TEST POINTS
F510(100001-) AND F525(100001-)**

M45972

-19-15MAY95

M45972

240
15
41

MX,24015CL,A26 -19-23OCT95

HEADLIGHT CIRCUIT TEST POINTS—OPTIONAL

Conditions:

- Transmission in neutral
- Park brake engaged
- PTO disengaged
- Ignition switch in RUN position
- Headlight switch in on position
- Meter negative (—) lead on battery negative (—) terminal
- Meter positive (+) lead on numbered test point
- Maximum voltage drop at test connections-0.2 volts

Test Location	Normal	If Not Normal
1. Battery positive (+) terminal	11.8—13.2 volts	Test battery.
2. Ignition switch terminal B	Battery voltage	Check battery cable connection, starter tie point, harness connector, fusible link, and red wire to switch.
3. Ignition switch terminal A	Battery voltage	Test ignition switch.
4. 20 amp fuse	Battery voltage	Check yel/red wire.
5. 20 amp fuse	Battery voltage	Check fuse.
6. Headlight switch	Battery voltage	Check yel/blk wire.
7. Headlight switch	Battery voltage	Test headlight switch.
8. Headlight	Battery voltage	Check yel/wht wire.
9. Headlight	Greater than 0 - less than 0.2 volts	Greater than 0.2 volts - check headlight ground circuit. 0 volts - replace light.
10. Headlight	Greater than 0 - less than 0.2 volts	Greater than 0.2 volts - check headlight and discharge light ground circuit. 0 volts - replace light.

MX,24015CL,A19 -19-23OCT95

240
15
42

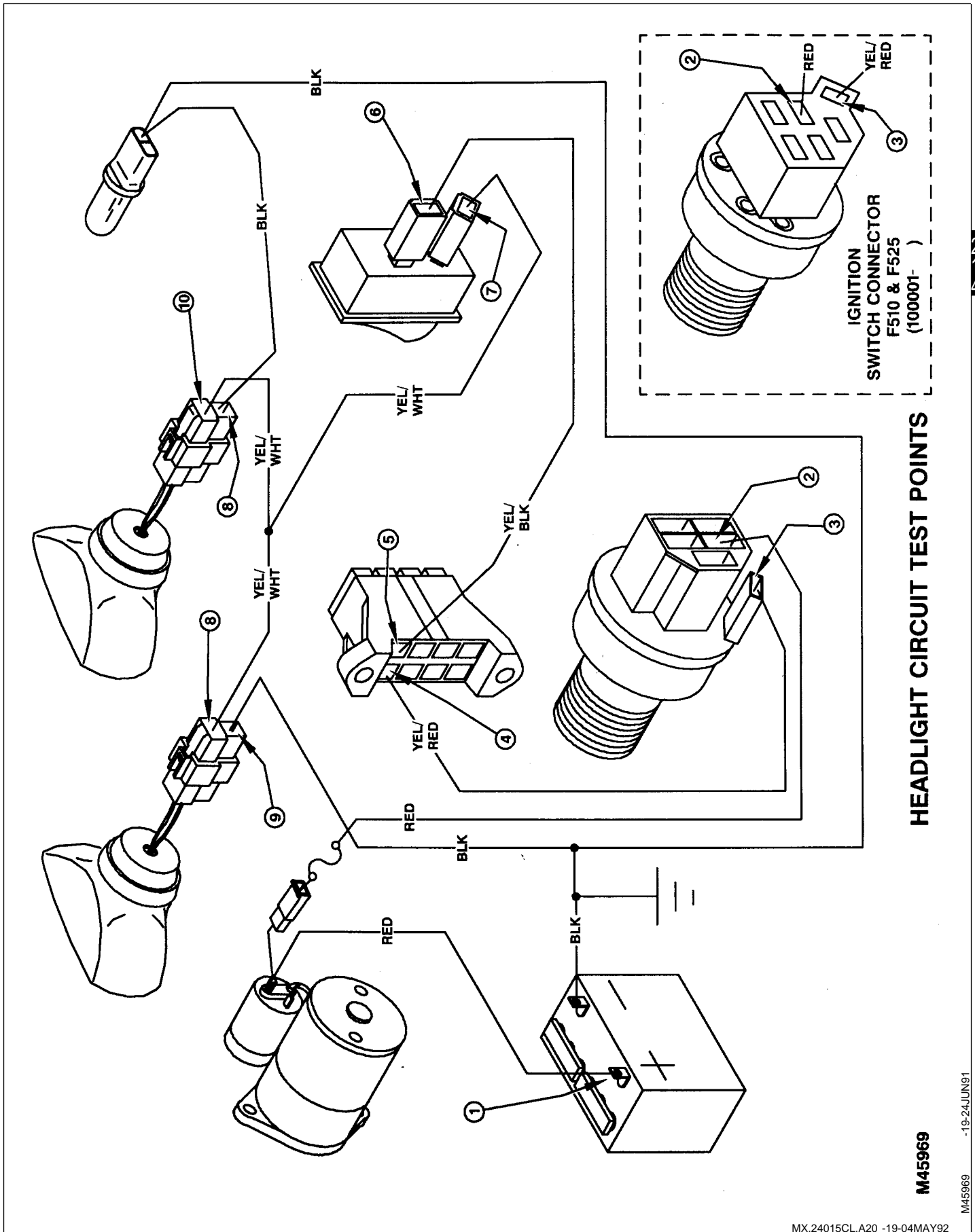

HEADLIGHT CIRCUIT TEST POINTS

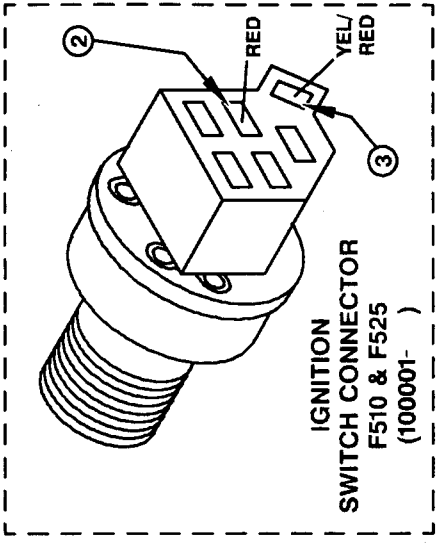

M45969

M45969 -19-24JUN91

MX,24015CL,A20 -19-04MAY92

COMMON CIRCUIT TESTS

Shorted Circuit

A shorted circuit may result in the wrong component operating (i.e. improper wire-to-wire contact). To test for a shorted or improperly wired circuit:

1. Turn component switch **ON**.
2. Start at the controlling switch of the component that should not be operating.
3. Follow the circuit and disconnect wires at connectors until component stops operating.
4. Shorted or improper connections will be the last two wires disconnected.

High Resistance or Open Circuit

High resistance or open circuits usually result in slow, dim or no component operation (i.e. poor, corroded, or disconnected connections). Voltage at the component will be low when the component is in operation.

To test for high resistance and open circuits:

1. Check all terminals and grounds of the circuit for corrosion.
2. If terminals are not corroded or loose, the problem is in the component or wiring.

Grounded Circuit

Grounded circuits usually result in no component operation or a blown fuse.

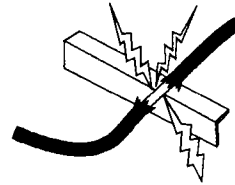
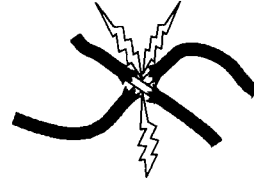

240
15
44

-JUN-05OCT95

M85600

-JUN-05OCT95

M85601

-JUN-05OCT95

M85602

MX,24015CL,27 -19-23OCT95

BATTERY TEST

Reason:

To check condition of battery and determine battery voltage.

Equipment:

- Hydrometer
- Voltmeter or JTO5685 Battery Tester

Procedure:

1. Clean battery terminals and top of battery.
2. Inspect battery terminals and case for breakage or cracks.
3. Check electrolyte level in each battery cell. Add clean, soft water as needed. If water was added, charge battery for 20 minutes at 10 amps.
4. Remove surface charge by placing a small load on the battery for 15 seconds.
5. Check specific gravity of each cell with a hydrometer.
6. Check battery voltage with voltmeter or JTO5685 Battery Tester.

Specifications:

- **Minimum specific gravity .. 1.225 with less than 50 point variation**
- **Minimum battery voltage .. 12.4 volts**

Results:

- Battery voltage less than 12.4 VDC, charge battery. (See Charge Battery in this group.)
- Battery voltage more than 12.4 VDC, test specific gravity.
- All cells less than 1.175, charge battery at 10 amp rate. (See Charge Battery in this group.)
- All cells less than 1.225 with less than 50 point variation, charge battery at 10 amp rate. (See Charge Battery in this group.)
- All cells more than 1.225 with less than 50 point variation, load test battery. (See Battery Load Test in this group.)
- More than 50 point variation: replace battery.

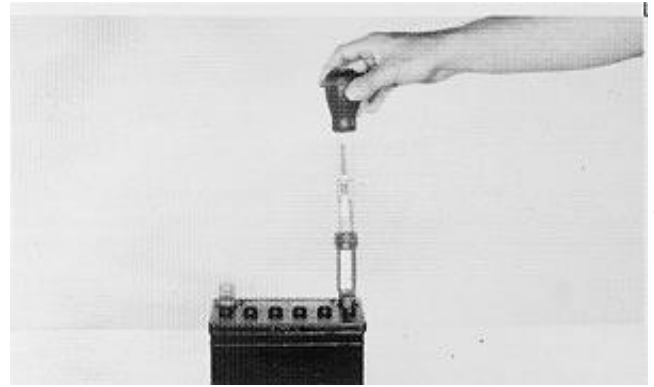

M49596 -UN-18SEP90

240
15
45

CHARGE BATTERY

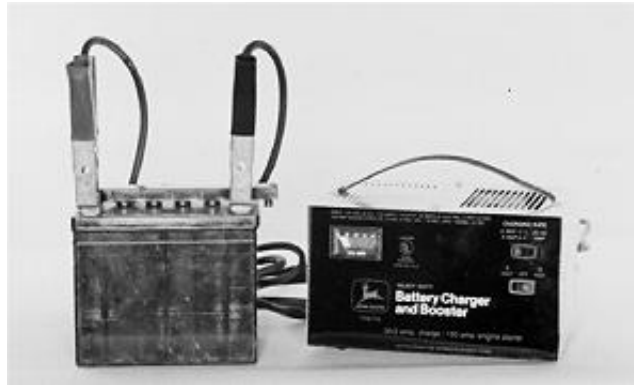

240
15
46

Reason:

To increase battery charge after battery has been discharged.

Equipment:

- Battery charger (variable rate)

Procedure:

NOTE: See Battery Test in this group before charging battery.

1. Connect variable rate charger to battery.

NOTE: Maximum charge time at boost setting is 10 minutes. Allow additional 5 minutes for each 10 degrees below 70 degrees F.

2. Start charger at slow rate. Increase charge rate one setting at a time. Check charger ammeter after 1 minute at each setting. Maintain 10 amp charge rate. Use boost setting as necessary.

3. Check if battery is accepting a 10 amp charge after 10 minutes at boost setting.

Results:

- Battery will not accept 10 amp charge after 10 minutes at boost setting: replace battery.
- Battery is accepting 10 amp charge after 10 minutes at boost setting, and battery did not need water: go to steps 6 and 7.
- Battery is accepting 10 amp charge after 10 minutes at boost setting, but battery did need water or all cells were below 1.175: go to steps 4 and 5.

4. Set charger at 15-25 amps.

IMPORTANT: Decrease charge rate if battery gases or bubbles excessively or becomes too warm to touch.

5. Check specific gravity after 30 minutes (60 minutes for maintenance-free battery).

Results:

- More than 50 point variation between cells: replace battery.
- Less than 50 point variation between cells: go to steps 6 and 7.

NOTE: If battery was discharged at slow or unknown rate, charge at 10—15 amps for 6—12 hours. (Maintenance-free battery: 12—24 hours.) If battery was discharged at fast rate, charge at 20—25 amps for 2—4 hours. (Maintenance-free battery: 4—8 hours.)

6. Continue charging battery until specific gravity is **1.230-1.265 points**.

7. Load test battery. (See Battery Load Test in this group.)

BATTERY LOAD TEST

Reason:

To check condition of battery under load.

Equipment:

- JTO5685 Battery Tester

Connections:

1. Turn load knob (A) of tester counter-clockwise to **OFF**.
2. Connect tester positive cable (B) to battery positive terminal.
3. Connect tester negative cable (C) to battery negative terminal.

Procedure:

1. Charge battery fully. (See Charge Battery in this group.)
2. Follow manufacturers instructions issued with load tester being used.

IMPORTANT: Turn load tester OFF immediately after reading is taken to prevent damage to tester internal components.

3. Record voltage reading and turn tester **OFF** immediately.

Specifications:

- 9.6 VDC or higher at 21°C (70°F) .. Good Battery
- Below 9.6 VDC at 21°C (70°F) .. Bad Battery

Results:

- If a fully charged battery does not pass the load test, replace the battery.

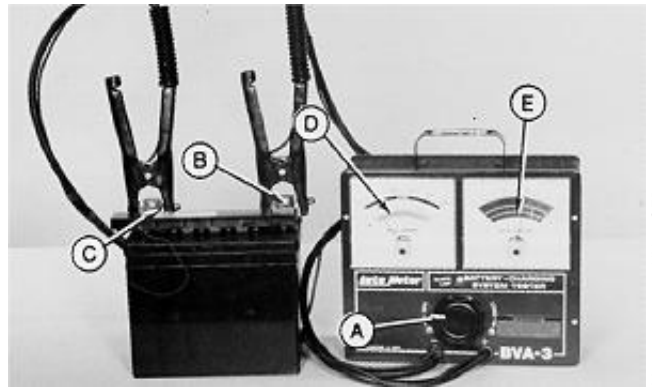

M49597 -UN-18SEP90
240
15
47

MX,24015CL,30 -19-23OCT95

REGULATED AMPERAGE TEST

Reason:

To determine charging output of the regulator/rectifier.

Equipment:

- JTO5712 Current Gun
- JTO5685 Battery Tester

Connections:

1. Move key switch to **OFF** position.
2. Put transaxle/transmission in **neutral**.
3. Engage park brake.
4. Raise and lock seat platform.
5. Raise rear shroud.
6. Put JTO5712 Current Gun over positive (+) battery cable (A). Set Current Gun for DC current.
7. Turn load knob (B) fully out (counterclockwise). Connect JTO5685 Battery Tester to battery.

Procedure:

IMPORTANT: Perform this test quickly to prevent damage to battery tester. DO NOT apply full load to battery for more than 5—10 seconds.

1. Start and run engine at full throttle.
2. Turn load knob in until voltage read on the tester voltage scale is 11 volts and read amperage.

Specifications:

- **F510 (PA420A) .. 11 amps (Minimum)**
- **F525 (PA540A) .. 13 amps (Minimum)**
- **Engine speed .. 3350 rpm**

Results:

- If reading does not meet specifications, perform Unregulated Voltage Output Test in this group.
- If unregulated voltage output meets the specifications and voltage and ground to the regulator/rectifier is verified, replace the regulator/rectifier

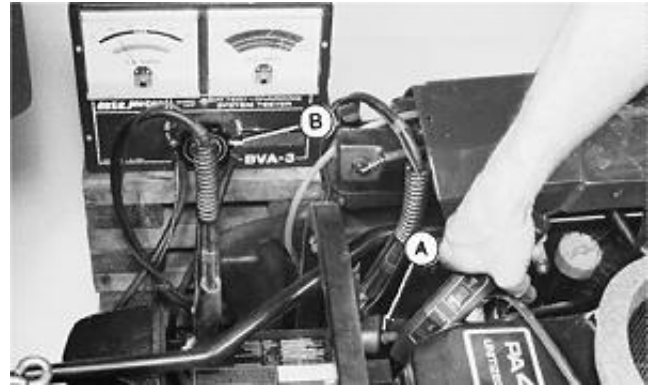

M45973 -UN-24JUN91

240
15
48

REGULATED VOLTAGE TEST

Reason:

To determine regulated voltage output of the regulator/rectifier.

Equipment:

- Voltmeter

Connections:

1. Move key switch to **OFF** position.
2. Put transaxle/transmission in **neutral**.
3. Engage park brake.
4. Raise and lock seat platform.
5. Raise rear shroud.
6. Remove surface charge from battery by placing a small load on the battery for 15 seconds.
7. Set voltmeter for 25 or 50 DC volts scale.
8. Connect meter red lead (A) to positive (+) battery terminal.
9. Connect meter black lead (B) to negative (—) battery terminal.

Procedure:

1. Start and run engine at **3350 rpm**.
2. Read meter several times during 5 minutes of running time. Voltage should read **12.2—14.7 VDC at 3350 rpm**.

Results:

- If the DC voltage stays below the minimum specification, see Unregulated Voltage Output Test in this group.
- If the DC voltage goes above the maximum specification, replace the regulator.

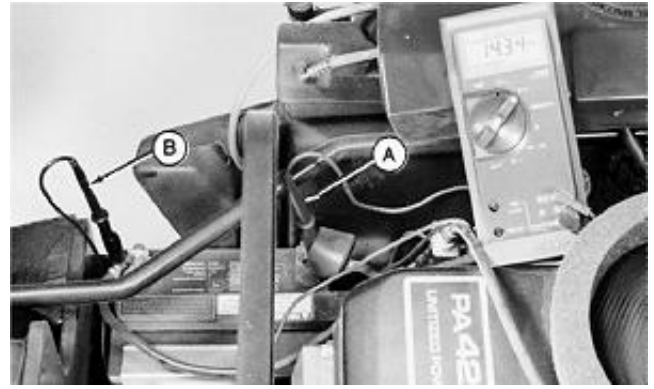

M45974
-UN-24JUN91
240
15
49

MX,24015CL,32 -19-23OCT95

UNREGULATED VOLTAGE OUTPUT TEST

Reason:

To measure stator voltage output to determine stator condition.

Equipment:

- Voltmeter

Connections:

1. Move key switch to **OFF** position.
2. Put transaxle/transmission in **neutral**.
3. Engage park brake.
4. Raise and lock seat platform.
5. Raise rear shroud.
6. Disconnect stator 2-pin connector.
7. Set voltmeter to AC voltage.
8. Connect meter across terminals (A).

Procedure:

1. Start and run engine at **3350 rpm**.
2. Measure stator voltage.

Specifications:

- **Engine speed .. 3350 rpm**
- **Minimum stator voltage**
 - F510 (PA420A) .. 30 VAC**
 - F525 (PA540A) .. 27 VAC**

Results:

- If reading is less than specifications, see Flywheel Magnet Test in this group. If flywheel magnet tests good, replace the stator.



M53144 -UN-21AUG89

240
15
50

MX,24015CL,33 -19-23OCT95

STARTER SOLENOID TEST

Reason:

To determine if starter solenoid or starter motor is defective.

Equipment:

- Jumper wire

Connections:

1. Move key switch to **OFF** position.
2. Put transaxle/transmission in **neutral**.
3. Engage park brake.
4. Raise and lock seat platform.
5. Raise rear shroud.
6. Disconnect and ground spark plug lead.
7. Disconnect purple wire from starter solenoid lead.

Procedure:

1. Connect jumper wire to positive battery terminal and briefly jump to starter solenoid terminal (A).

Results:

- Starter runs: solenoid is good, check circuit wiring. (See Cranking Circuit Test Points in this group.)
 - Starter does not run: go to step 2.
2. Remove red and black rubber boots from terminals (B and C).
 3. Connect jumper wire between starter solenoid large terminals (B and C).

Results:

- Starter runs: Replace solenoid.
- Starter does not run: Check battery cables then replace starter.

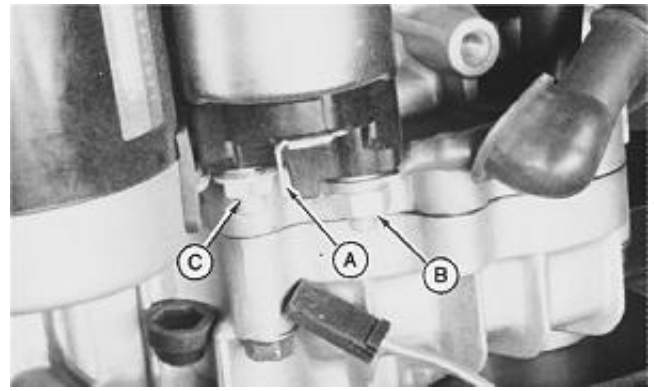

M45713
-UN-20NOV99
240
15
51

MX,24015CL,34 -19-23OCT95

STARTER AMP DRAW TEST

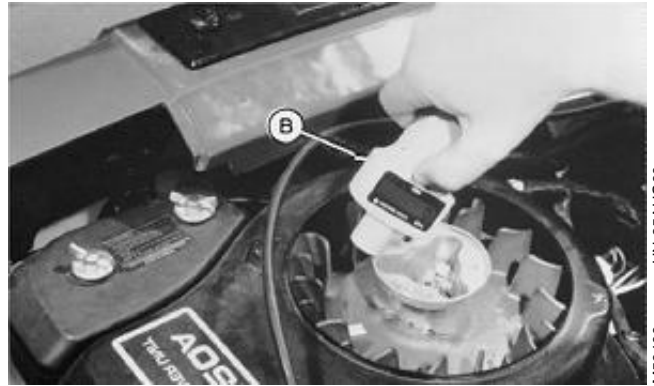
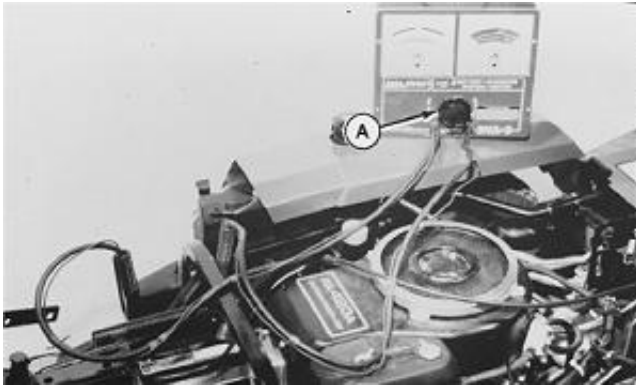

Reason:

To determine the amperage required to crank the engine and check starter motor operation under load.

Equipment:

- JTO5685 Battery Tester
- Photo Tachometer

Connections:

1. Put transmission in **neutral**.
2. Engage park brake.
3. Test system ground connections. (See Ground Circuit Test in this group.)
4. Test battery. (See Battery Test in this group.)
5. Turn knob (A) of battery tester counter-clockwise to **OFF**.
6. Connect red clamp of battery tester to positive (+) terminal of battery and black clamp of tester to negative (—) terminal of battery.
7. Install tachometer reflective tape on flywheel.
8. Remove spark plug high tension lead and ground to engine.

Procedure:

1. Crank engine and read voltage on DC voltage scale of battery tester and check engine rpm using the photo tachometer (B).

2. Turn key switch to **OFF** position.

IMPORTANT: Perform the following procedure within 15 seconds to prevent electrical damage to components.

3. Turn knob of battery tester clockwise until the DC voltage is the same as when cranking.

4. Read DC amperage on battery tester.

5. Turn load knob fully counterclockwise.

Specifications:

- **Maximum starter amp draw - PA420A ..60 amps at 500 rpm**
- **Maximum starter amp draw - PA540A ..85 amps at 500 rpm**

Results:

- If amperage is above specification, or rpm is low, see Starter No-Load RPM And Amperage Test in this group to determine if starter is binding or damaged.
- If starter is good, check internal engine, traction or PTO drive for binding or damage.

STARTER NO-LOAD AMPERAGE AND RPM TEST

Reason:

To determine if starter is binding or has excessive amperage draw under no-load.

Equipment:

- JTO5712 Current Gun

Procedure:

IMPORTANT: Complete this test in 20 seconds or less to prevent starter damage.

NOTE: Check that battery is fully charged and of proper size to ensure accuracy of test.

1. Connect jumper cables to battery.
2. Connect negative (—) cable to starter body. Connect positive (+) cable to terminal (A).
3. Use jumper wire to briefly connect terminals (A) and (B).
4. Measure starter amperage. Amperage should read a **maximum of 50 amps**.

Results:

- If amperage is out of specification, check for binding or seizing bearings, sticking brushes, dirty or worn commutator. Repair or replace starter.

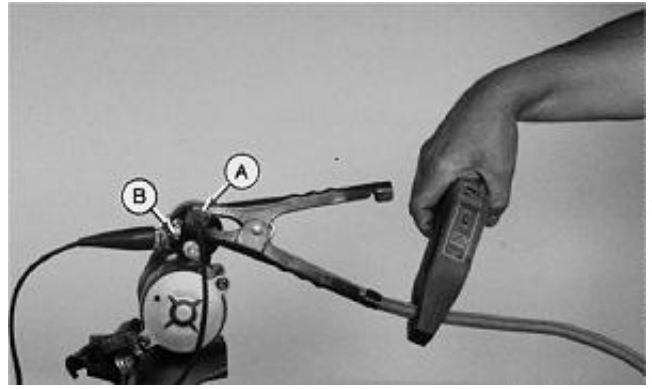

M45667 -UN-20NOV99

240
15
53

MX,24015CL,36 -19-23OCT95

IGNITION COIL AIR GAP ADJUSTMENT

Reason: To adjust the air gap between the ignition coil and the flywheel to a specific dimension needed for proper ignition timing.

Equipment:

- 0.3 mm (0.012 in.) feeler gauge

Connections:

1. Put key switch in **OFF** position.
2. Put transmission in **NEUTRAL**.
3. Raise and lock seat platform.
4. Raise rear shroud.
5. Remove blower housing. (See Remove And Install Blower Housing in Section 20, Group 10.)

Procedure:

1. Turn flywheel magnet away from coil.
2. Loosen coil mounting screws (A).

IMPORTANT: Both coil legs must have the same air gap as the engine is very sensitive to this adjustment.

3. Insert a feeler gauge between flywheel and coil legs. Align flywheel magnet with coil. Adjust gap to **0.3 mm (0.012 in.)**, or if a misfire conditions exists, adjust gap to **0.25 mm (0.010 in.)**.
4. Hold coil in this position and tighten coil mounting screws. Turn flywheel to remove feeler gauge.

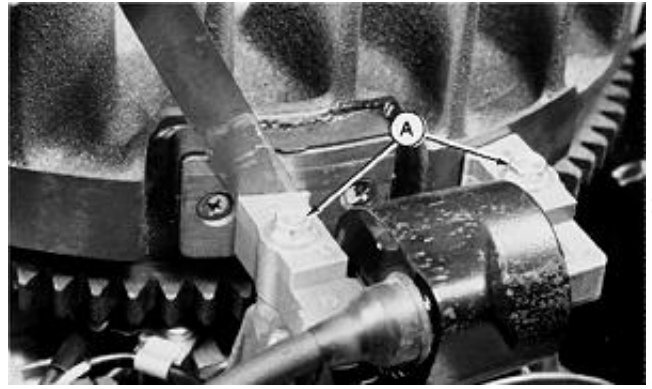

M48358 -UN-27OCT89

240
15
54

MX,24015CL,37 -19-23OCT95

IGNITION COIL TEST—F510 (—100203) AND F525 (—100392)

Reason:

To determine condition of ignition coil windings.

Equipment:

- Ohmmeter

Procedure:

1. Put key switch in **OFF** position.
2. Put transmission in **neutral**.
3. Raise and lock seat platform.
4. Raise rear shroud.
5. Remove spark plug cap from spark plug wire.
6. Disconnect primary lead wire.
7. Measure resistance between primary lead (A) and core (B). Resistance should be **0.48—0.72 ohms**.
8. Measure resistance between spark plug lead (C) and core (B). Resistance should be **10,900—16,300 ohms**.

Results:

- If resistance does not meet specifications, replace the ignition coil.

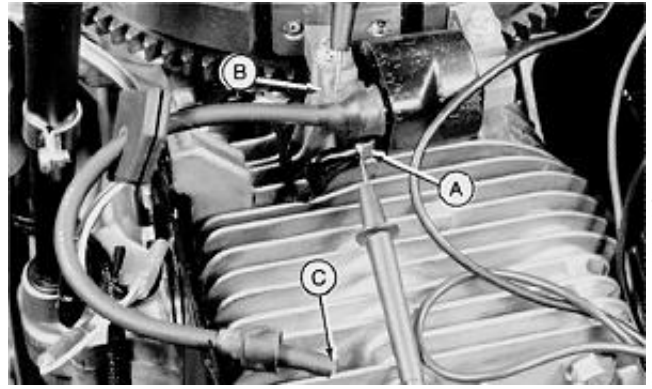

M48360
-UN-11NOV89
240
15
55

MX,24015CL,38 -19-23OCT95

IGNITION COIL TEST—F510 (100204—) AND F525 (100393—)

Reason:

To determine condition of ignition coil windings.

Equipment:

- Ohmmeter

Procedure:

1. Put key switch in **OFF** position.
2. Put transmission in **neutral**.
3. Raise and lock seat platform.
4. Raise rear shroud.
5. Remove spark plug cap from spark plug wire.
6. Disconnect primary lead wire.
7. Measure resistance between primary lead (A) and core (B). Resistance should be **0.4—0.8 ohms**.
8. Measure resistance between spark plug lead (C) and core (B). Resistance should be **8,700—13,100 ohms**.

Results:

- If resistance does not meet specifications, replace the ignition coil.

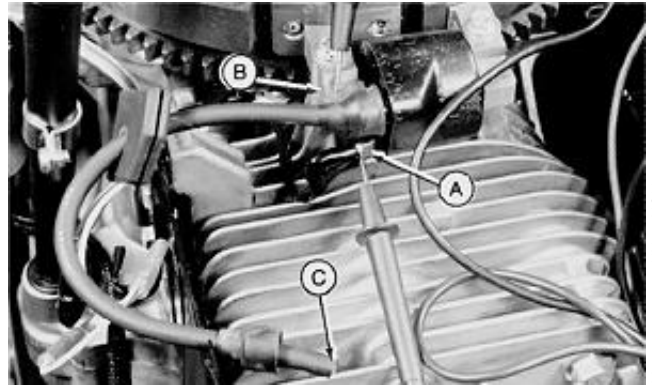

M48360 -UN-11NOV89

240
15
56

MX,24015CL,38A -19-23OCT95

IGNITION MODULE TEST

Reason:

To determine if ignition module is defective.

Procedure:

The ignition module is very sensitive to the type of meter used to check resistance. Due to variations in the meters, the best way to determine if the ignition module is good is to replace the questionable ignition module with a known good module.

Results:

- If the new ignition module does not solve the problem, check the other ignition components.



M49888 -JUN-14DEC90

MX,24015CL,39 -19-23OCT95

SPARK PLUG CAP TEST—F510 (—100203) AND F525 (—100392)

Reason:

To check resistance of spark plug cap.

Equipment:

- Ohmmeter

Procedure:

1. Put transmission in **neutral**.
2. Turn key switch to **OFF** position.
3. Raise and lock seat platform.
4. Raise rear shroud.
5. Disconnect spark plug cap.
6. Measure resistance across spark plug cap terminals.
Resistance should be about the same as marked on the cap.

Results:

- If resistance does not meet specifications, replace the spark plug cap.



M48364 -UN-25OCT89

240
15
57

MX,24015CL,40 -19-23OCT95

ADJUST SPARK PLUG GAP

Reason:

To maintain the correct gap between the center electrode and the tab needed to produce a good spark.

Equipment:

- 0.76 mm (0.030 in.) feeler gauge

Procedure:

IMPORTANT: Do not clean spark plug with sandpaper or abrasives. Engine scoring can result.

1. Put transmission in **neutral**.
2. Turn key switch to **OFF** position.
3. Raise and lock seat platform.
4. Raise rear shroud.
5. Disconnect spark plug cap.
6. Scrape or wire brush deposits from spark plug.
7. Inspect spark plug for:
 - Cracked porcelain
 - Pitted or damaged electrodes.
8. Check spark plug gap (A) using a feeler gauge. Set gap to **0.76 mm (0.030 in.)**.
9. Install and tighten spark plug to **25 N-m (18 lb-ft)**.



M48365 -UN-25OCT89

240
15
58

MX,24015CL,41 -19-23OCT95

SPARK TEST

Reason:

Check overall condition of ignition system.

Equipment:

- D-05351ST Spark Tester

Connections:

1. Put transmission in **neutral**.
2. Turn key switch to **OFF** position.
3. Park brake engaged. PTO disengaged.
4. Raise and lock seat platform.
5. Raise rear shroud.
6. Remove high tension lead (A) from spark plug.
7. Connect spark tester (B) to spark plug.
8. Connect high tension lead to spark tester.

NOTE: Do not adjust spark tester gap beyond 5.0 mm (0.200 in.) as damage to ignition system components could occur.

9. Adjust spark tester gap to 4.2 mm (0.166 in.) with screw (C).
8. Set key switch to **run** position.

Procedure:

1. Spin engine with starter and watch spark (D) at spark tester. If engine will start, watch spark with engine running.

Specifications:

- Steady, strong, blue spark.

Results:

- If spark is weak, or if no spark, install a new spark plug and test again.
- If spark is still weak, or still no spark, run tests on individual components to find cause of malfunction.

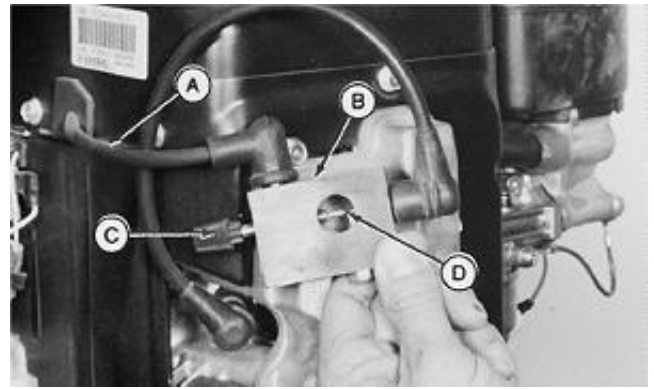

A—High Tension Lead
 B—Spark Tester
 C—Adjuster Screw
 D—Spark

M49887 -UN-14DEC90

240
15
59

KEY SWITCH TEST

Reason:

To make sure the correct terminals have continuity.

Equipment:

- Ohmmeter or continuity tester

Procedure:

1. Turn key switch to **OFF** position.
2. Put transmission in **neutral**. Engage park brake.
3. Disengage PTO.
4. Remove switch panel.
5. Disconnect key switch connector.
6. Check terminals for continuity using a ohmmeter or continuity tester.

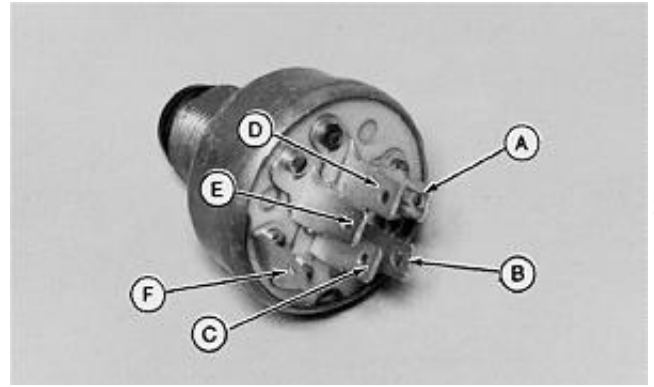

- A—Magneto Terminal
- B—Ground Terminal
- C—Battery Terminal
- D—S1 Terminal
- E—S2 Terminal
- F—Accessory Terminal

KEY SWITCH CONTINUITY

KEY SWITCH POSITION	TERMINAL CONTINUITY
OFF	A and B
RUN	C and F
START	C and F, D and E

Results:

- Replace key switch if continuity is not correct.

240
15
60

M49684 -UN-27SEP90

MX,24015CL,43 -19-23OCT95

FLYWHEEL MAGNET TEST

Reason:

To make sure the flywheel magnet has enough force to induce current in the ignition coil.

Connections:

1. Put transmission in **neutral**.
2. Put key switch in **OFF** position.
3. Raise and lock seat platform.
4. Raise rear shroud.
5. Remove blower housing. (See Remove and Install Blower Housing in Section 20, Group 10.)
6. Turn flywheel so magnet is away from coil.

Procedure:

1. Loosely hold handle of a steel shaft screwdriver so that shaft is about 25 mm (1 in.) away from flywheel magnet.

Results:

- If screwdriver shank is not pulled into the magnet, replace the flywheel.



M48367
-UN-25OCT89

240
15
61

MX,24015CL,44 -19-23OCT95

BRAKE SWITCH TEST AND ADJUSTMENT

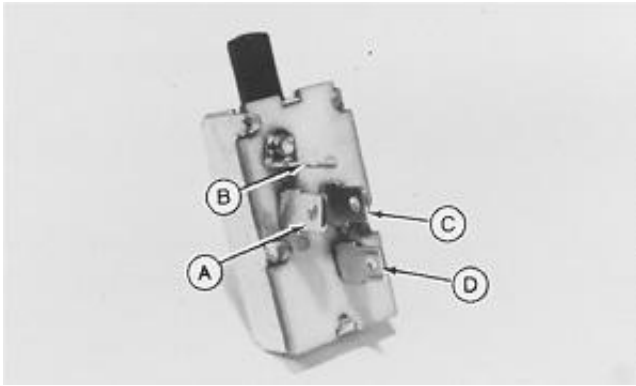

M53140 -UN-25AUG89

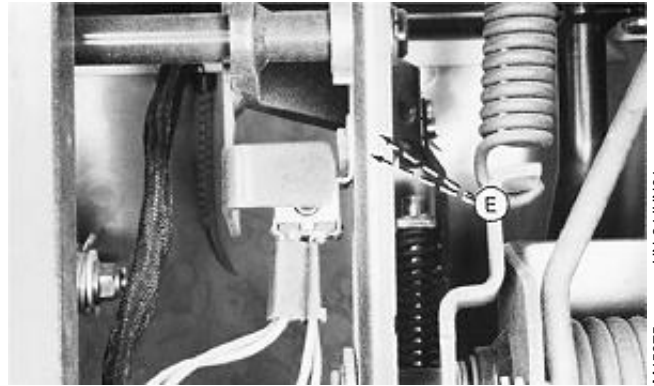

M45975 -UN-24JUN91

240
15
62

Reason:

To make sure the brake switch has continuity when the brake pedal is depressed.

Equipment:

- Ohmmeter or continuity tester

NOTE: The brake switch is located under the center of the foot platform.

Connections:

1. Turn key switch to **OFF** position.
2. Put transmission in **neutral**.



CAUTION: Block wheels to prevent unit from moving during test.

3. Disconnect brake switch connector.

Procedure:

1. Connect meter leads to brake switch terminals (A and B).
2. Depress brake pedal and read meter.
3. Release brake pedal and read meter.
4. Connect meter leads to brake switch terminals (C and D).

5. Depress brake pedal and read meter.

6. Release brake pedal and read meter.

Specifications:

- **Brake pedal depressed:**
Terminals A and B .. no continuity
Terminals C and D .. continuity
- **Brake pedal released:**
Terminals A and B .. continuity
Terminals C and D .. no continuity

Results:

- If the brake switch terminal continuity is not correct, adjust the brake switch.
 1. Depress brake pedal and engage park brake lock lever.
 2. Loosen nuts (E).
 3. Move the brake switch downward until terminals C and D have continuity.
 4. Hold brake switch in position and tighten nuts.
- If the continuity is still not correct, replace the brake switch.

PTO SWITCH TEST—F510 (—011957) AND F525 (—012519)

Reason:

To make sure terminal continuity is correct in the **ON** and **OFF** positions.

Equipment:

- Ohmmeter or continuity tester

Connections:

1. Turn key switch to the **OFF** position.
2. Put transmission in **neutral**. Engage park brake.
3. Remove switch panel.
4. Disconnect PTO switch connector.

Procedure:

1. Put PTO switch in the **OFF** position.
2. Check continuity between terminals (A and B) and (C and D).
3. Move PTO switch to the **ON** position.
4. Check continuity between terminals (A and B) and (C and D).

Specifications:

- PTO switch **OFF** continuity .. (A and B)
- PTO switch **ON** continuity .. (C and D)

Results:

- If continuity is not correct, replace PTO switch.

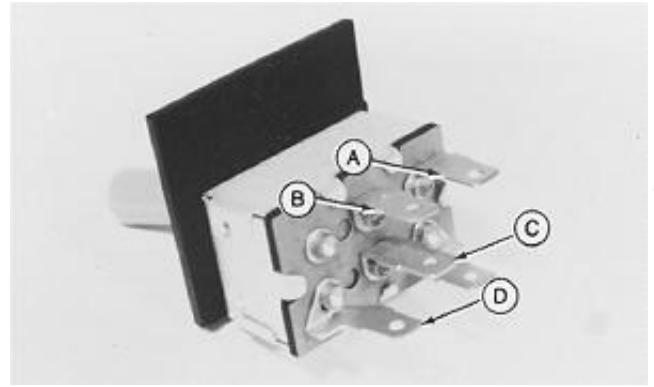

M53216
-UN-25AUG89

240
15
63

MX,24015CL,46 -19-23OCT95

PTO SWITCH TEST—F510 (011958—120459) AND F525 (012520—121629)

Reason:

To make sure terminal continuity is correct in the **ON** and **OFF** positions.

Equipment:

- Ohmmeter or continuity tester

Connections:

1. Turn key switch to the **OFF** position.
2. Put transmission in **neutral**. Engage park brake.
3. Remove switch panel.
4. Disconnect PTO switch connector.

Procedure:

1. Put PTO switch in the **OFF** position.
2. Check continuity between terminals (A and B), (B and C), and (D and E).
3. Move PTO switch to the **ON** position.
4. Check continuity between terminals (A and B), (B and C), and (D and E).

Specifications:

- PTO switch **OFF** continuity .. (A and B) and (D and E)
- PTO switch **ON** continuity .. (B and C)

Results:

- If continuity is not correct, replace PTO switch.

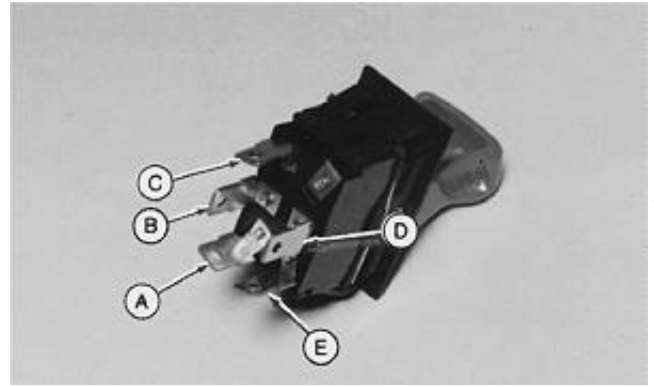

M48938 -UN-20NOV90

240
15
64

MX,24015CL,47 -19-23OCT95

PTO SWITCH TEST—F510 (120460—) AND F525 (121630—)

Reason:

To make sure terminal continuity is correct in the **ON** and **OFF** positions.

Equipment:

- Ohmmeter or continuity tester

Connections:

1. Turn key switch to the **OFF** position.
2. Put transmission in **neutral**. Engage park brake.
3. Remove switch panel.
4. Disconnect PTO switch connector.

Procedure:

1. Put PTO switch in the **OFF** position.
2. Check continuity between terminals (A and B), (C and E), and (D and E).
3. Move PTO switch to the **ON** position.
4. Check continuity between terminals (A and B), (C and E), and (D and E).

Specifications:

- PTO switch **OFF** continuity .. (A and B) and (C and E) only
- PTO switch **ON** continuity .. (D and E)

Results:

- If continuity is not correct, replace PTO switch.

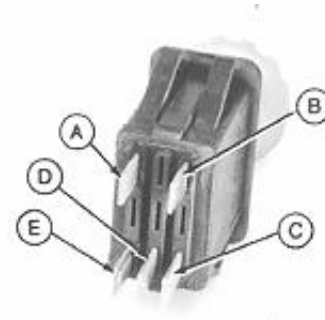

M46300
-UN-10SEP92

240
15
65

MX,24015CL,47A -19-23OCT95

PTO CLUTCH TEST

Reason:

To check operation of PTO clutch.

Equipment:

- Two Jumper Wires

Connections:

1. Turn key switch to **OFF** position.
2. Put transmission in **neutral**.
3. Engage park brake.
4. Raise and lock seat platform.
5. Raise rear shroud.

NOTE: PTO clutch connector is located on the right side of the machine near the oil filter.

6. Disconnect PTO clutch connector.



CAUTION: Be careful to prevent sparks from jumper wires around battery and fuel system.

7. Connect jumper wire to battery positive terminal and PTO clutch terminal (B).
8. Connect jumper wire to battery negative terminal and PTO clutch terminal (A).

Procedure:

Look and listen for operation of PTO clutch.

Results:

- If the PTO clutch does not engage, check and adjust PTO clutch air gap. If PTO clutch still does not engage, replace clutch.

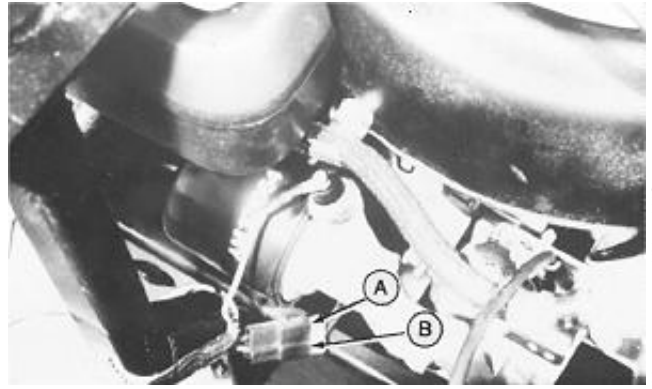

M53147 -UN-25AUG89

240
15
66

MX,24015CL,48 -19-23OCT95

PTO CLUTCH ADJUSTMENT

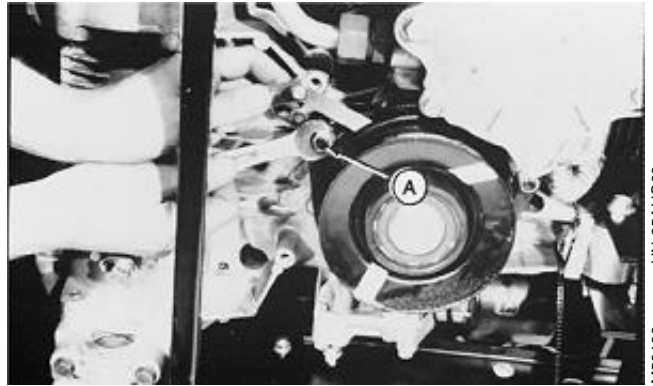

Reason:

To set the PTO clutch air gap at a specific dimension for proper operation.

Equipment:

- 0.51 mm (0.020 in.) feeler gauge

Procedure:

IMPORTANT: The adjustment/break-in procedure should be performed any time the PTO clutch is repaired or replaced. This procedure should be performed by the DEALER ONLY and should not be attempted by untrained personnel.

1. Put transmission in **neutral**.
2. Put key switch and PTO switch in **OFF** position.
3. Engage park brake.
4. Insert feeler gauge through slot in brake plate to check PTO clutch air gap. Gap between clutch armature and rotor should be **0.38—0.64 mm (0.015—0.025 in.)**. Check air gap at all three slots.

Results:

- If the PTO clutch air gap is not correct, adjust lock nut (A) until the 0.51 mm (0.020 in.) feeler gauge begins to bind between the armature and rotor. Use a sweeping motion with feeler gauge while making this adjustment. DO NOT overtighten nut.
- Repeat procedure on other two adjusting nuts.
- Perform PTO Clutch Break-in procedure.

Break-in Procedure:

1. Start and run engine at full throttle.
2. With no load on mower:
 - Put PTO switch in **ON** position (engage PTO clutch) and run for 10 seconds.
 - Put PTO switch in **OFF** position (disengage PTO clutch) and wait 10 seconds.
3. Repeat the procedure 12—15 cycles to properly burnish (break-in) the PTO clutch.
4. Recheck adjustment.

SEAT SWITCH TEST

Reason:

To make sure the seat switch terminals have continuity when the operator is on the seat (plunger depressed).

Equipment:

- Ohmmeter or continuity tester

NOTE: The seat switch is located on the rear of the seat mounting bracket.

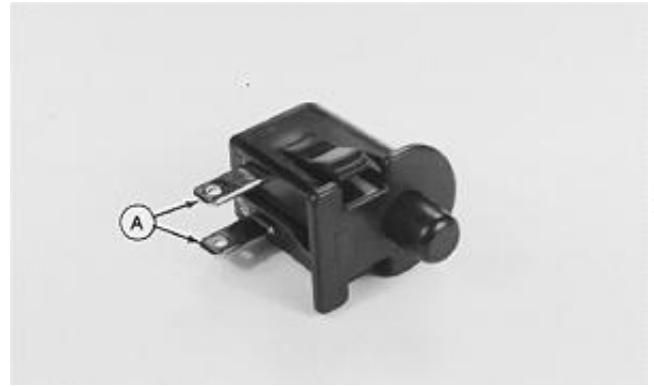

M48379 -UN-25OCT89

Connections:

1. Put transmission in **neutral**.
2. Put key switch in the **OFF** position.
3. Engage park brake.
4. Disconnect seat switch connector.

Procedure:

1. Depress the seat switch plunger.
2. Check continuity across switch terminals (A). There should be **continuity**.
3. Release the seat switch plunger.
4. Check continuity across switch terminals. There should be **no continuity**.

Results:

- If the seat switch does not have continuity with the operator on the seat, check the seat switch bracket and spring for damage.
- If the seat switch does not have continuity with the plunger depressed, or the continuity is not correct, replace the switch.

MX,24015CL,50 -19-23OCT95

240
15
68

HEADLIGHT SWITCH TEST (OPTIONAL)

Reason:

To make sure the headlight switch terminals have continuity when the headlight switch is **ON**.

Equipment:

- Ohmmeter or continuity tester

Connections:

1. Put transmission in **neutral**.
2. Put key switch in **OFF** position.
3. Disconnect headlight switch connector.

Procedure:

1. Move headlight switch to the **ON** position.
2. Check continuity across switch terminals (A). There should be **continuity** across terminals.
3. Move headlight switch to the **OFF** position. There should be **no continuity** across terminals.

Results:

- If continuity is not correct, replace headlight switch.

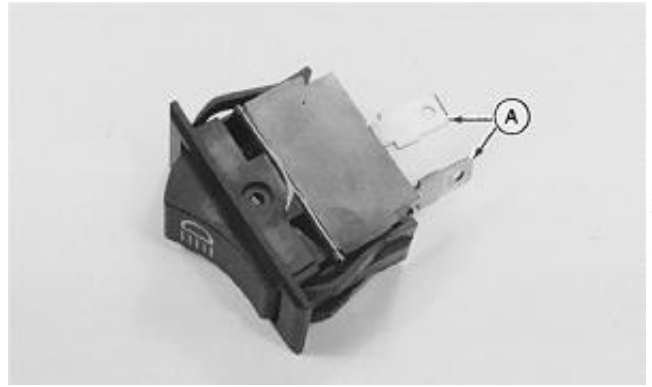

M48378
-UN-25OCT89

240
15
69

MX,24015CL,51 -19-23OCT95

OIL PRESSURE SENDER SWITCH TEST

Reason:

Determine the proper operation of the oil pressure sender switch.

Equipment:

- Ohmmeter

NOTE: The oil pressure sender switch is located on the right side of the machine near the oil filter.



M45680 -UN-29NOV90

240
15
70

Connections:

1. Raise and lock seat platform.
2. Raise rear shroud.
3. Set ohmmeter for 1X ohms scale.
4. Remove wire (A) from sender switch.

IMPORTANT: Do not allow connector of wire to contact the engine or frame as there will be voltage at it during the test.

5. Connect black lead of meter to engine block (B).
6. Connect red lead of meter to terminal (C) of sender switch.

Procedure:

1. Start and run engine.
2. Read meter.

Specifications:

- With engine **NOT** running .. continuity to ground
- With engine **running** .. no continuity to ground

Results:

- If the switch does **NOT** have continuity to ground when the engine is **NOT** running, replace the switch.
- If the switch does have continuity to ground with the engine running, check engine oil pressure (see Oil Pressure Test in Section 220, Group 15). If the oil pressure is to specifications, replace the switch.

TEST FUEL SHUT-OFF SOLENOID

Reason:

To determine if fuel shut-off solenoid plunger retracts when the solenoid is energized.

Equipment:

- Jumper wire

NOTE: Fuel shut-off solenoid is located on the right side of the machine at the bottom of the carburetor float bowl.

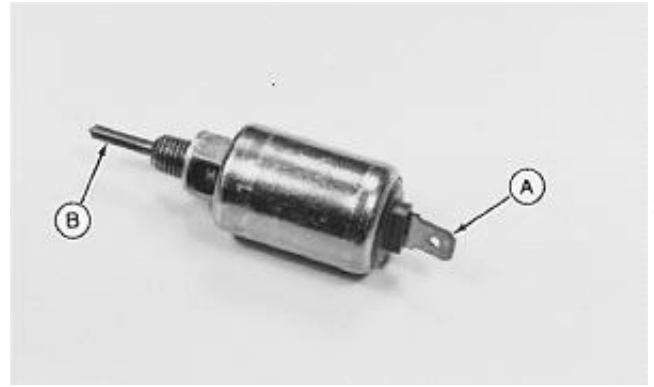

Connections:

1. Put transmission in **neutral**.
2. Put key switch in **OFF** position.
3. Raise and lock seat platform.
4. Raise rear shroud.
5. Disconnect fuel shut-off solenoid connector.



CAUTION: Gasoline will drain from carburetor when solenoid is removed. Keep gasoline away from sparks, flame, or hot engine parts or personal injury can result.

6. Remove fuel shut-off solenoid.

Procedure:

1. Connect a jumper wire from the battery positive terminal to solenoid terminal (A).
2. Connect a jumper wire from the battery negative terminal to the solenoid threads.

NOTE: It may be necessary to push plunger (B) inward slightly for plunger to retract.

Specifications:

- Plunger must retract when solenoid is energized.
- Plunger must extend when solenoid is de-energized.

Results:

- If plunger does not move, replace fuel shut-off solenoid.

M48368 -UN-25OCT89

240
15
71

RELAY TEST

Reason:

To check relay terminal continuity in the energized and de-energized condition.

Equipment:

- Ohmmeter or continuity tester
- Jumper wire

NOTE: Relays are mounted to the frame cross-member in front of the engine.

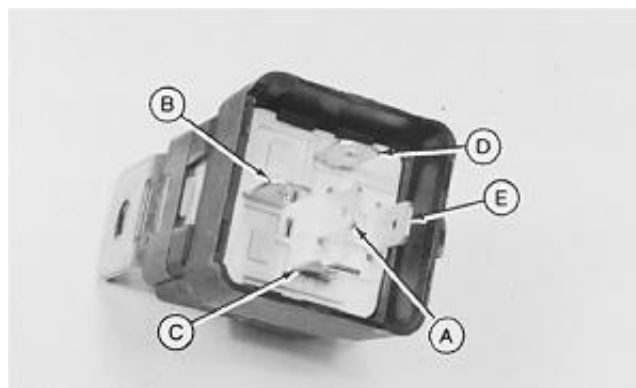

M48376 -UN-25OCT89

Procedure:

1. Put transmission in **neutral**.
2. Disengage PTO.
3. Engage park brake.
4. Turn key switch to **OFF** position.
5. Raise and lock seat platform.
6. Disconnect relay connector.
7. Check terminal continuity using an ohmmeter or continuity tester.

Specifications:

- There should be continuity between relay terminals 87A-30 (A and B) and 85-86 (C and D). There should be no continuity between relay terminals 87-30 (E and B).

8. Connect a jumper wire from battery positive terminal to relay terminal 85 (C). Connect a jumper wire from relay terminal 86 (D) to battery negative terminal.

Specifications:

- There should be continuity between relay terminals 87-30 (E and B).

Results:

- If continuity is not correct, replace relay.

MX,24015CL,54 -19-23OCT95

240
15
72

TEST LOW FUEL SENSOR

Reason:

To make sure the low fuel sensor terminals have continuity when the float is at the bottom position.

Equipment:

- Ohmmeter or continuity tester

*NOTE: This test requires removing the fuel sensor from the tank. Before performing test, check the rest of the low fuel light circuit. (See Hourmeter, Low Fuel and Oil Pressure Circuit Test Points in this group.) If circuit checks out as good, siphon fuel from tank (capacity **10.4 L [2.75 U.S. gal]**), until low fuel light is **ON**. Add fuel until light is **OFF**. If this proves inconclusive, perform the follow porcedure:*

Connections:

1. Put transmission in **neutral**.
2. Disengage PTO.
3. Engage park brake.
4. Put key switch in **OFF** position.
5. Remove left fender. (See Left Fender Replacement in Section 80, Group 15.)
6. Disconnect low fuel sensor connector.
7. Remove low fuel sensor from fuel tank. (See Repair Fuel Tank in Section 30, Group 05.)

Procedure:

1. Move float (C) to bottom position (inside ring).
2. Check continuity across switch terminals (A and B).
3. Move float upward just out of bottom ring. Check continuity across terminals.

Specifications:

- **Float at bottom position .. continuity**
- **Float just out of bottom ring .. no continuity**

Results:

- If continuity is not correct, replace low fuel sensor.

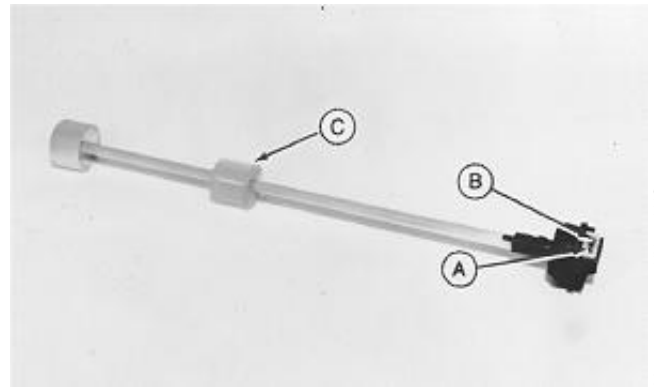

M53145
-UN-25AUG89

240
15
73

GROUND CIRCUIT TEST

Reason:

To check for opens or poor connections in the ground circuit.

Equipment:

- Ohmmeter or continuity tester

NOTE: Ground connection is located on the left side of the machine near the starter.

Procedure:

1. Put transmission in **neutral**.
2. Disengage PTO.
3. Engage park brake.
4. Turn key switch to **OFF** position.
5. Raise and lock seat platform.
6. Raise rear shroud.
7. Connect ohmmeter or continuity tester to negative (—) terminal of battery and ground terminal of circuit or component to be tested.
6. Check for continuity.

Results:

- If continuity is not indicated, check for open wiring or poor connections.

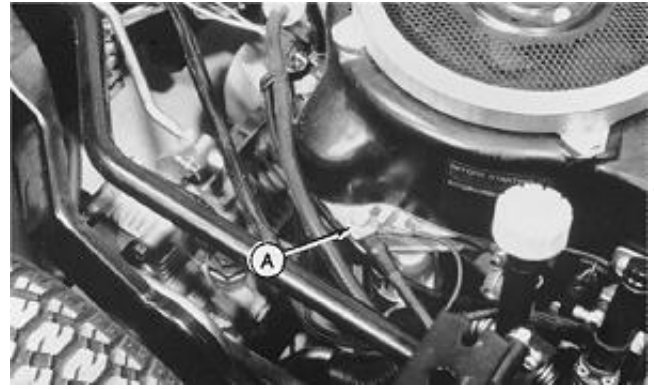

A—Battery Negative Terminal and Wiring Harness to Engine Ground

240
15
74

-UN-25AUG89
M53494

MX,24015CL,56 -19-23OCT95

SCHEMATIC INFORMATION

The wiring schematics are drawn with the power in, or battery positive, circuit across the top and the ground, or battery negative, circuit across the bottom. The flow is then, as much as possible, from top to bottom through each circuit and component. All components are shown in the off position.

MX,24020CL,1 -19-04MAY92

240
20
1

F510 (—011957) AND F525 (—012519) ELECTRICAL SCHEMATIC LEGEND

A—Battery	I—PTO Clutch	Q—Light Switch	X—Ignition Module
B—Fuse Link	J—PTO Relay	R—Low Fuel Light	Y—Ignition Coil
C—Starter Solenoid	K—Ignition Relay	S—Fuel Shutoff Solenoid	Z—Stator
D—Brake Switch	L—Seat Switch	T—Hourmeter	AA—Spark Plug
E—Engine/PTO Fuse	M—Oil Pressure Sensor	U—Ignition Switch	BB—Discharge Light
F—Headlight Fuse	N—Fuel Sensor	V—Charge Fuse 30 Amp	CC—Starter
G—Neutral/Start Fuse	O—Oil Pressure Light	W—Regulator/Rectifier	DD—Engine Ground
H—PTO Switch	P—Headlights		

240
20
2

MX,24020CL,2 -19-23OCT95

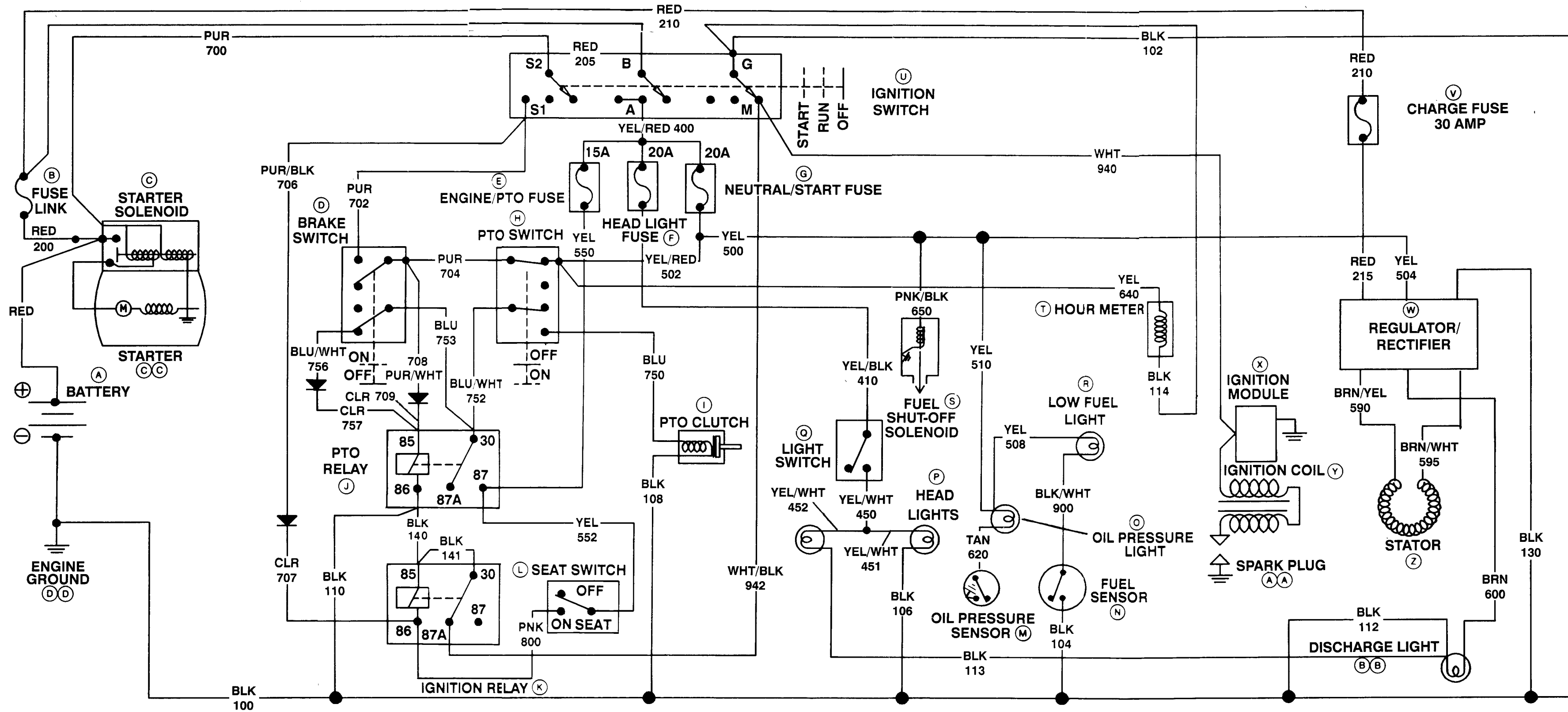

F510(-011957) AND F525(-012519) ELECTRICAL SCHEMATIC

M45949

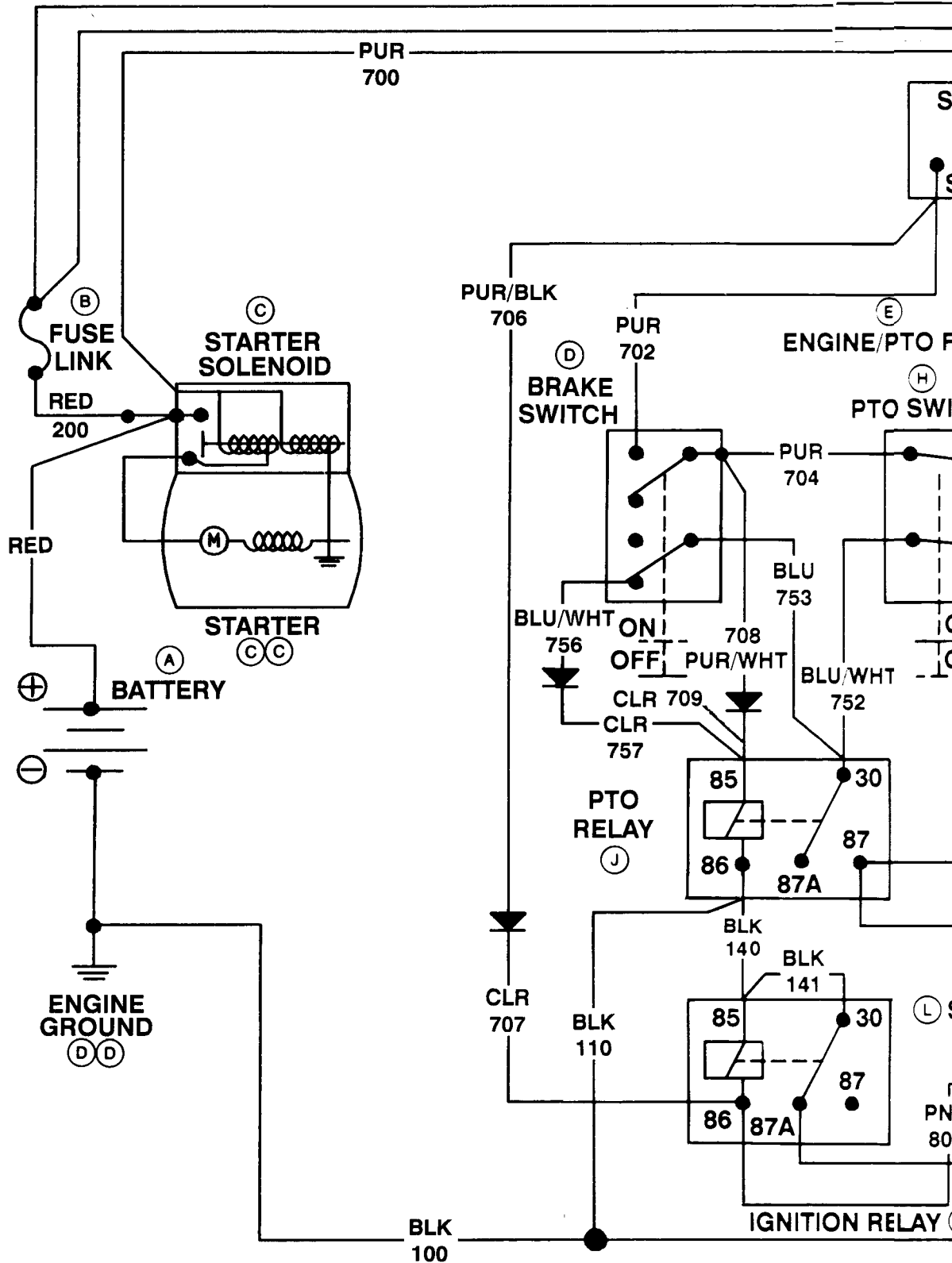

M45949

F510

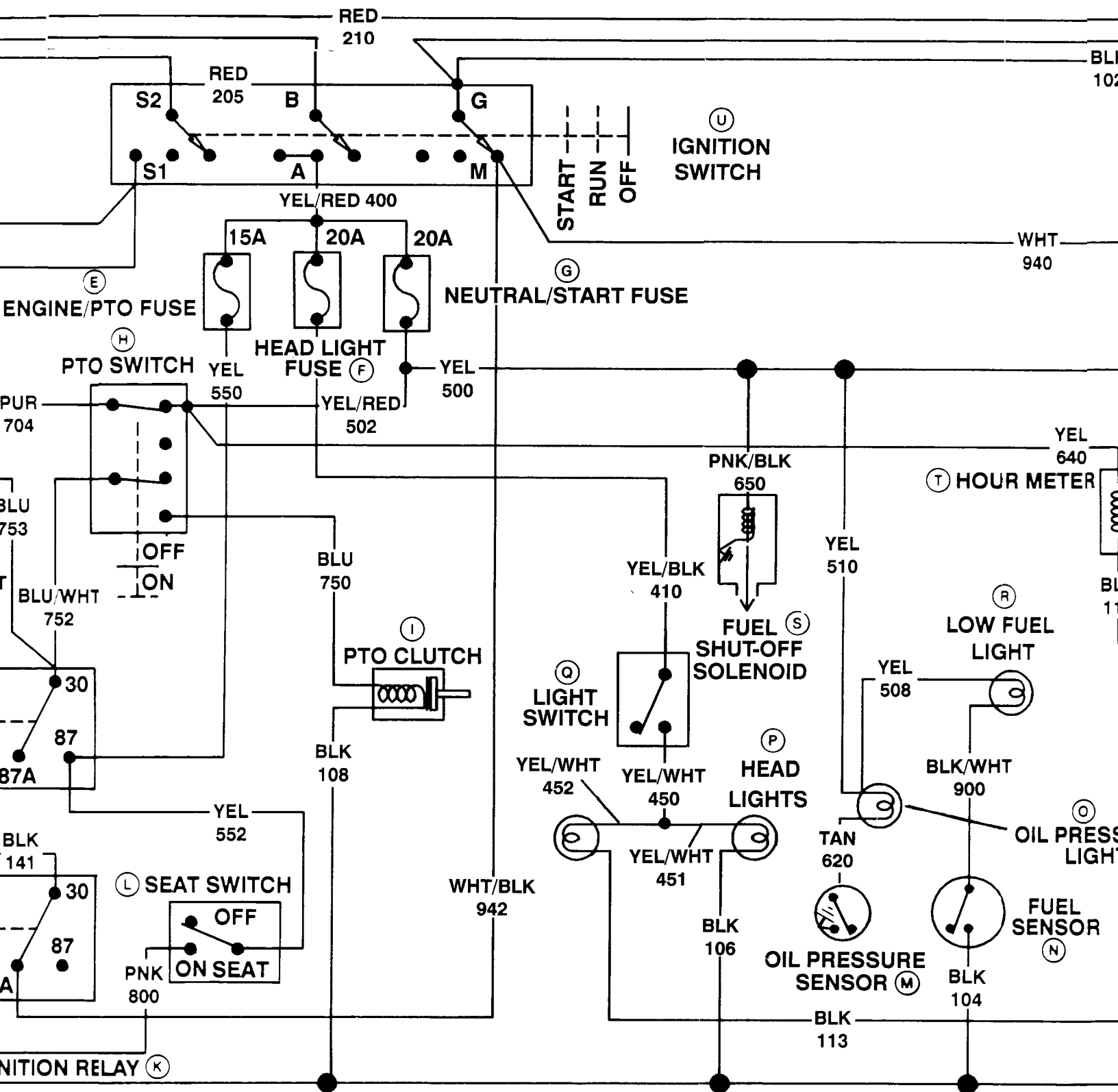

F510(-011957) AND F525(-012519) ELECTRICAL SCHEMATIC

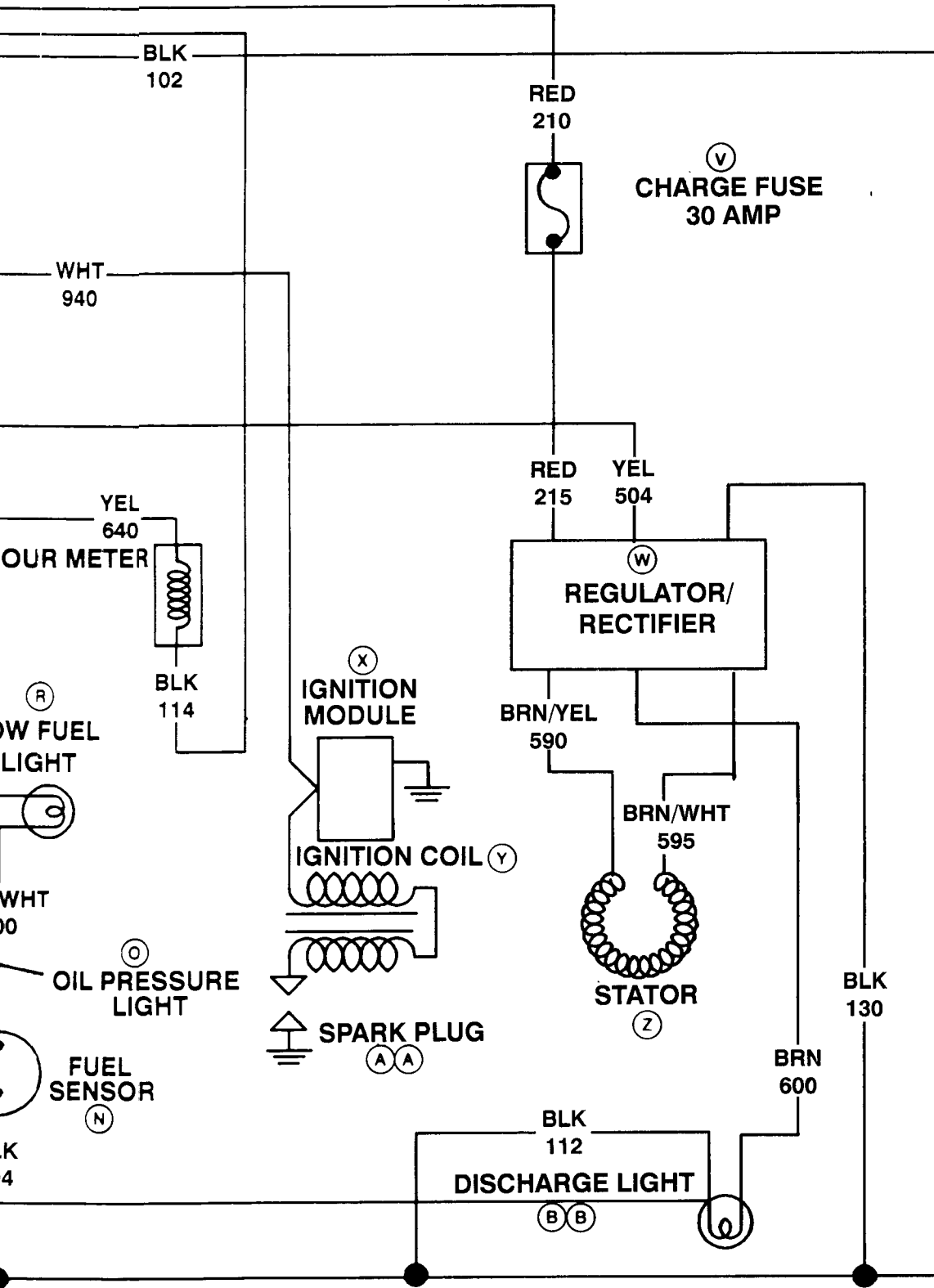

TIC

F510 (—011957) AND F525 (—012519) WIRING HARNESS LEGEND

A—Battery At Starter
B—Fuse Link
C—Starter Solenoid
D—Brake Switch
E—Engine/PTO Fuse
F—Headlight Fuse
G—Neutral/Start Fuse

H—PTO Switch
I—PTO Clutch
J—PTO Relay
K—Ignition Relay
L—Seat Switch
M—Oil Pressure Sensor

N—Fuel Sensor
O—Oil Pressure Light
P—Headlights
Q—Light Switch
R—Low Fuel Light
S—Fuel Shutoff Solenoid

T—Hourmeter
U—Ignition Switch
V—Charge Fuse 30 Amp
W—Regulator/Rectifier
BB—Discharge Light
DD—Engine Ground

MX,24020CL,4 -19-23OCT95

240
20
5

F510 (011958—) AND F525 (012520—) ELECTRICAL SCHEMATIC LEGEND

A—Battery	I—PTO Clutch	Q—Light Switch	X—Ignition Module
B—Fuse Link	J—PTO Relay	R—Low Fuel Light	Y—Ignition Coil
C—Starter Solenoid	K—Ignition Relay	S—Fuel Shutoff Solenoid	Z—Stator
D—Brake Switch	L—Seat Switch	T—Hourmeter	AA—Spark Plug
E—Engine/PTO Fuse	M—Oil Pressure Sensor	U—Ignition Switch	BB—Discharge Light
F—Headlight Fuse	N—Fuel Sensor	V—Charge Fuse 30 Amp	CC—Starter
G—Neutral/Start Fuse	O—Oil Pressure Light	W—Regulator/Rectifier	DD—Engine Ground
H—PTO Switch	P—Headlights		

NOTE: Wiring harnesses for later models feature plug-in diodes.

MX,24020CL,6 -19-23OCT95

240
20
6

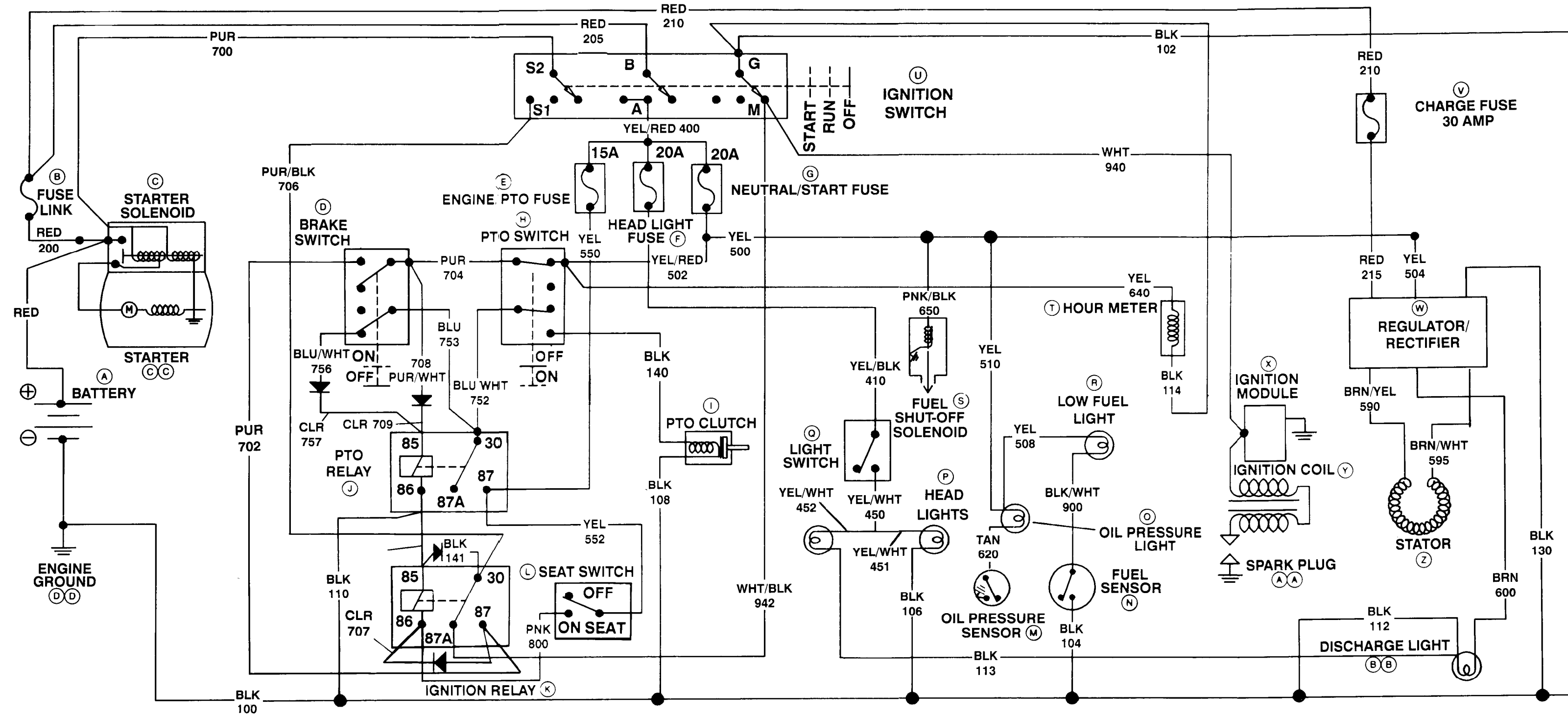

F510(011958-) AND F525(012520-) ELECTRICAL SCHEMATIC

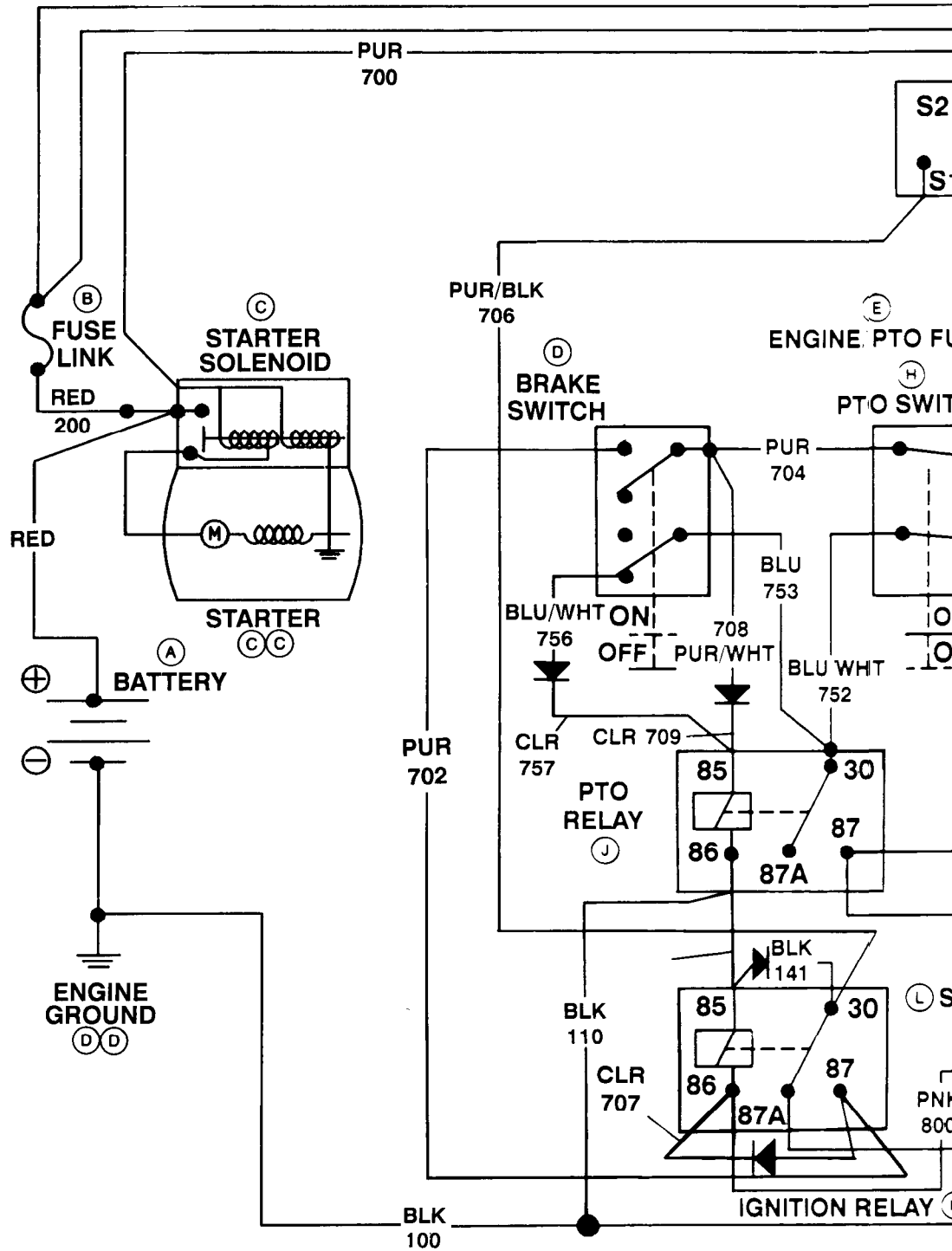

M45951

F510(011

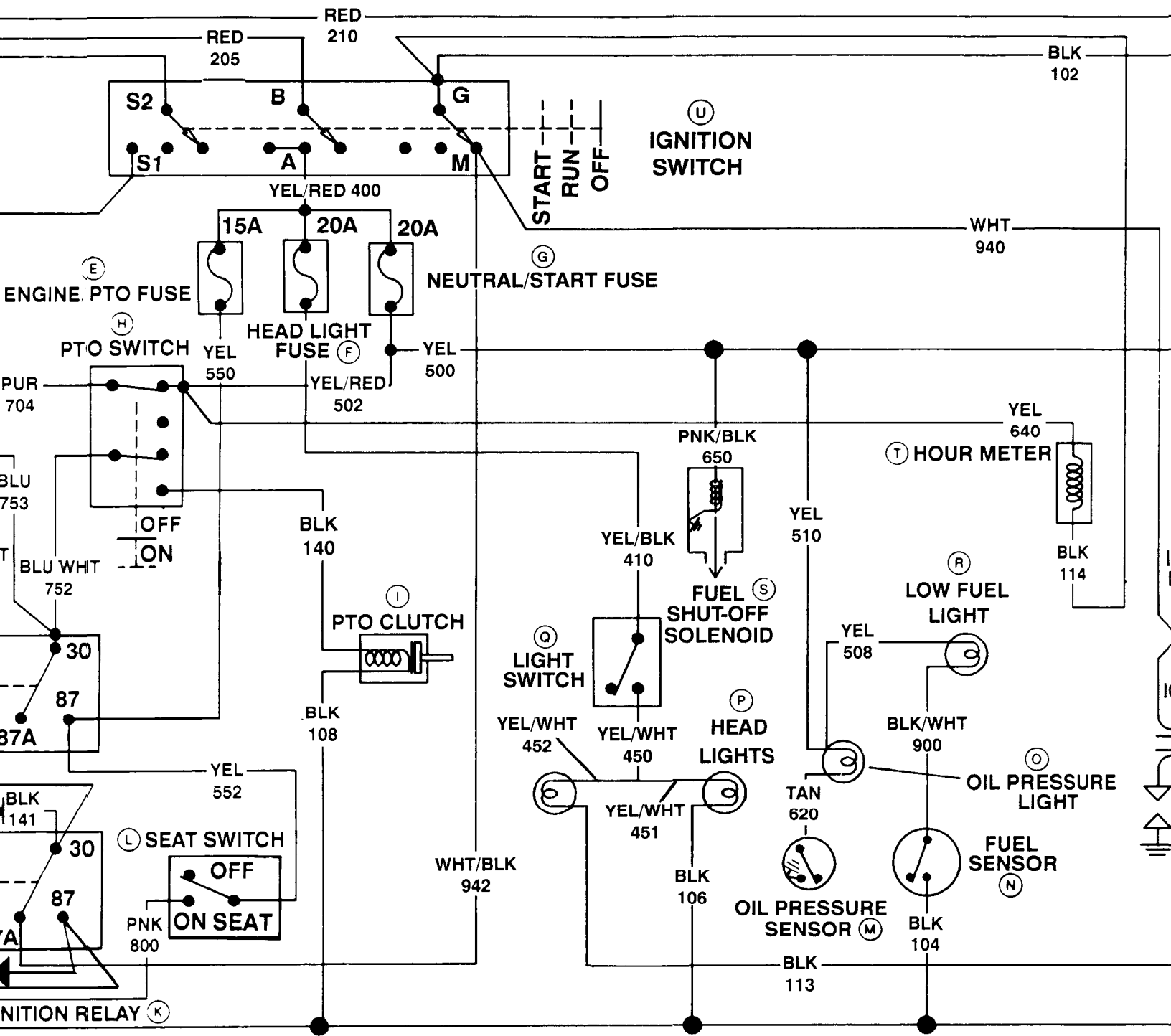

F510(011958-

) AND F525(012520-

) ELECTRICAL SCHEMATIC

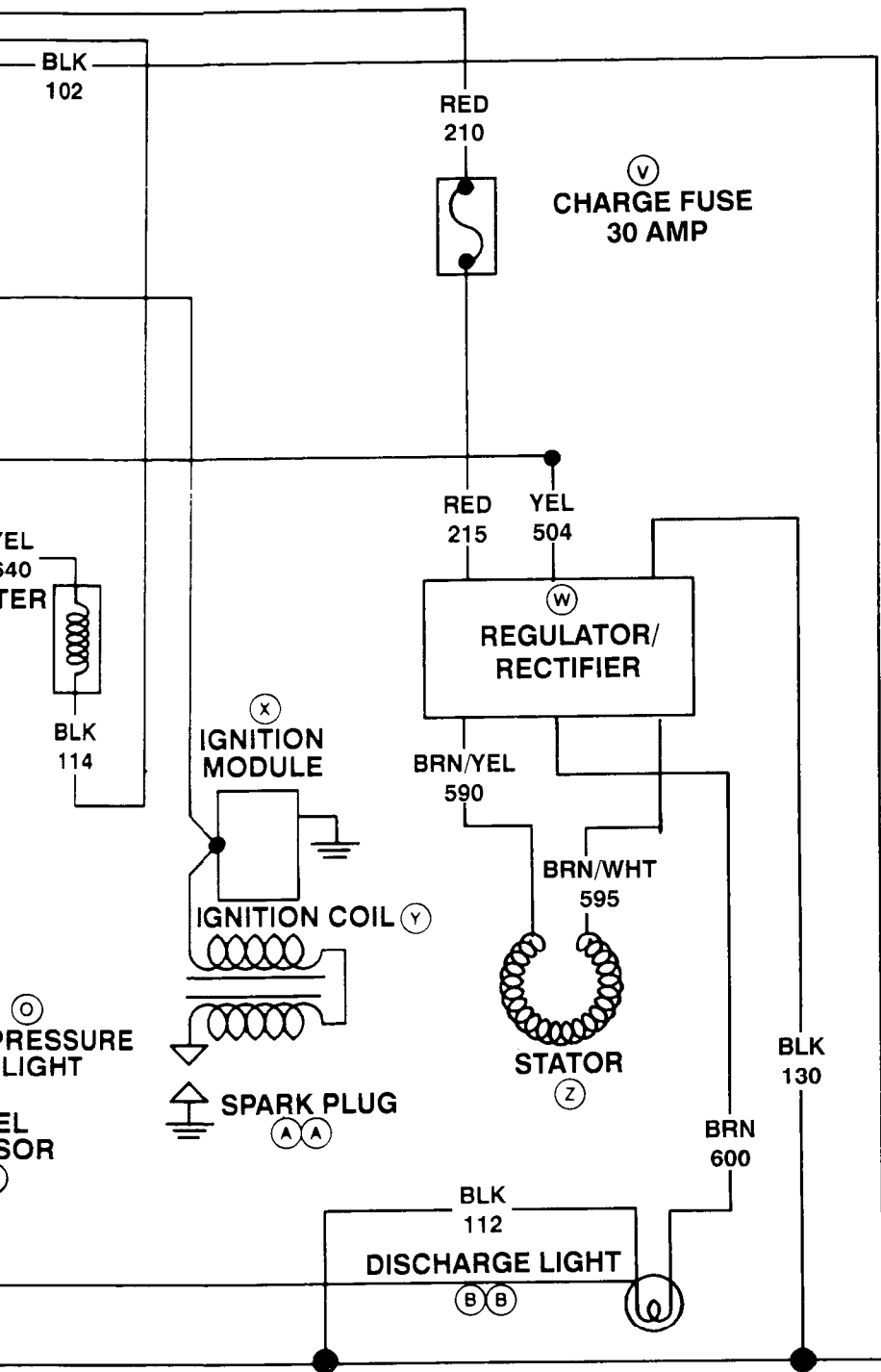

F510 (011958—100000) AND F525 (012520—100000) WIRING HARNESS LEGEND

A—Battery At Starter
B—Fuse Link
C—Starter Solenoid
D—Brake Switch
E—Engine/PTO Fuse
F—Headlight Fuse
G—Neutral/Start Fuse

H—PTO Switch
I—PTO Clutch
J—PTO Relay
K—Ignition Relay
L—Seat Switch
M—Oil Pressure Sensor

N—Fuel Sensor
O—Oil Pressure Light
P—Headlights
Q—Light Switch
R—Low Fuel Light
S—Fuel Shutoff Solenoid

T—Hourmeter
U—Ignition Switch
V—Charge Fuse 30 Amp
W—Regulator/Rectifier
BB—Discharge Light
DD—Engine Ground

MX,24020CL,8 -19-23OCT95

240
20
9

F510 (100001—) AND F525 (100001—) WIRING HARNESS LEGEND

A—Battery At Starter
B—Fuse Link
C—Starter Solenoid
D—Brake Switch
E—Engine/PTO Fuse
F—Headlight Fuse
G—Neutral/Start Fuse

H—PTO Switch
I—PTO Clutch
J—PTO Relay
K—Ignition Relay
L—Seat Switch
M—Oil Pressure Sensor

N—Fuel Sensor
O—Oil Pressure Light
P—Headlights
Q—Light Switch
R—Low Fuel Light
S—Fuel Shutoff Solenoid

T—Hourmeter
U—Ignition Switch
V—Charge Fuse 30 Amp
W—Regulator/Rectifier
BB—Discharge Light
DD—Engine Ground

NOTE: *Wiring harnesses for later models feature plug-in diodes.*

240
20
10

MX,24020CL,10 -19-23OCT95

CIR NUM	WIRE SIZE mm2	COLOR
100	2.0	blk
102	1.0	blk
104	1.0	blk
106	0.8	blk
108	1.0	blk
110	1.0	blk
112	0.8	blk
113	0.8	blk
114	0.8	blk
130	2.0	blk
140	1.0	blk
141	0.5	diode
200	1.0	red
205	3.0	red
210	3.0	red
215	2.0	red
400	3.0	yel/red
410	1.0	yel/blk
450	1.0	yel/wht
451	0.8	yel/wht
452	0.8	yel/wht
500	2.0	yel
502	1.0	yel/red
504	1.0	yel
508	0.8	yel
510	0.8	yel
550	1.0	yel
552	1.0	yel
590	3.0	brn/yel
595	3.0	brn/wht
600	0.8	brn
620	0.8	tan
640	0.8	yel
650	1.0	pnk/blk
700	1.0	pur
702	1.0	pur
704	1.0	pur
706	1.0	pur/blk
707	0.5	diode
708	1.0	pur/wht
709	0.8	diode
750	1.0	blu
752	1.0	blu/wht
753	1.0	blu
756	1.0	blu/wht
757	0.8	diode
800	1.0	pnk
900	0.8	blk/wht
940	1.0	wht
942	1.0	wht/blk

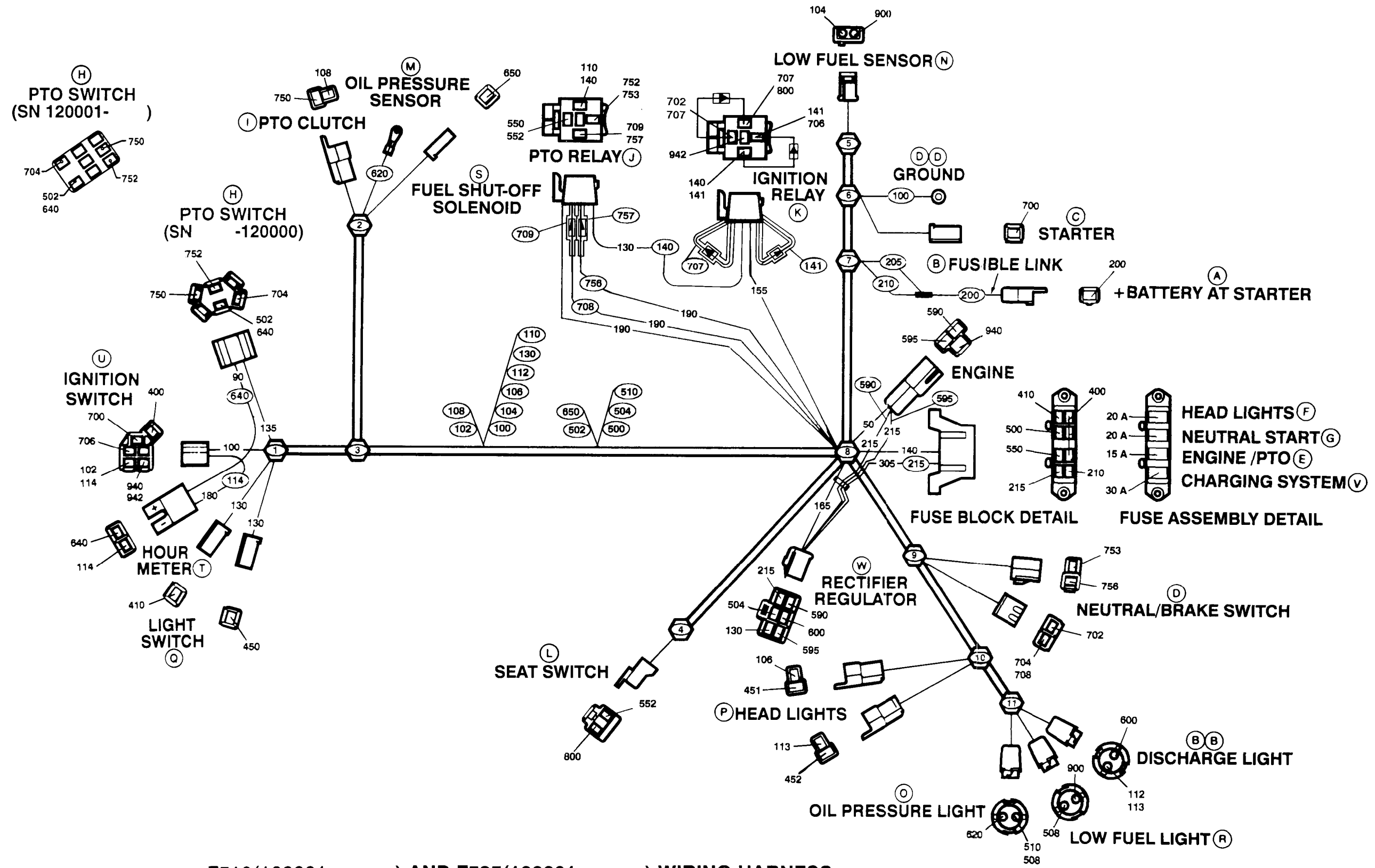

CIR NUM	WIRE SIZE mm2	COLOR
100	2.0	blk
102	1.0	blk
104	1.0	blk
106	0.8	blk
108	1.0	blk
110	1.0	blk
112	0.8	blk
113	0.8	blk
114	0.8	blk
130	2.0	blk
140	1.0	blk
141	0.5	diode
200	1.0	red
205	3.0	red
210	3.0	red
215	2.0	red
400	3.0	yel/red
410	1.0	yel/blk
450	1.0	yel/wht
451	0.8	yel/wht
452	0.8	yel/wht
500	2.0	yel
502	1.0	yel/red
504	1.0	yel
508	0.8	yel
510	0.8	yel
550	1.0	yel
552	1.0	yel
590	3.0	brn/yel
595	3.0	brn/wht
600	0.8	brn
620	0.8	tan
640	0.8	yel
650	1.0	pnk/blk
700	1.0	pur
702	1.0	pur
704	1.0	pur
706	1.0	pur/blk
707	0.5	diode
708	1.0	pur/wht
709	0.8	diode
750	1.0	blu
752	1.0	blu/wht
753	1.0	blu
756	1.0	blu/wht
757	0.8	diode
800	1.0	pnk
900	0.8	blk/wht
940	1.0	wht
942	1.0	wht/blk

(H)
PTO SWITCH
(SN 120001-)

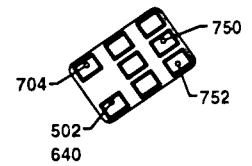

PTO
(SN

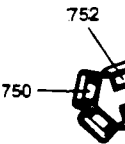

(U)
IGNITION
SWITCH

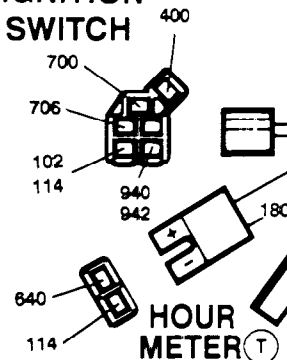

HOUR
METER (T)



LIGHT
SWITCH
(Q)

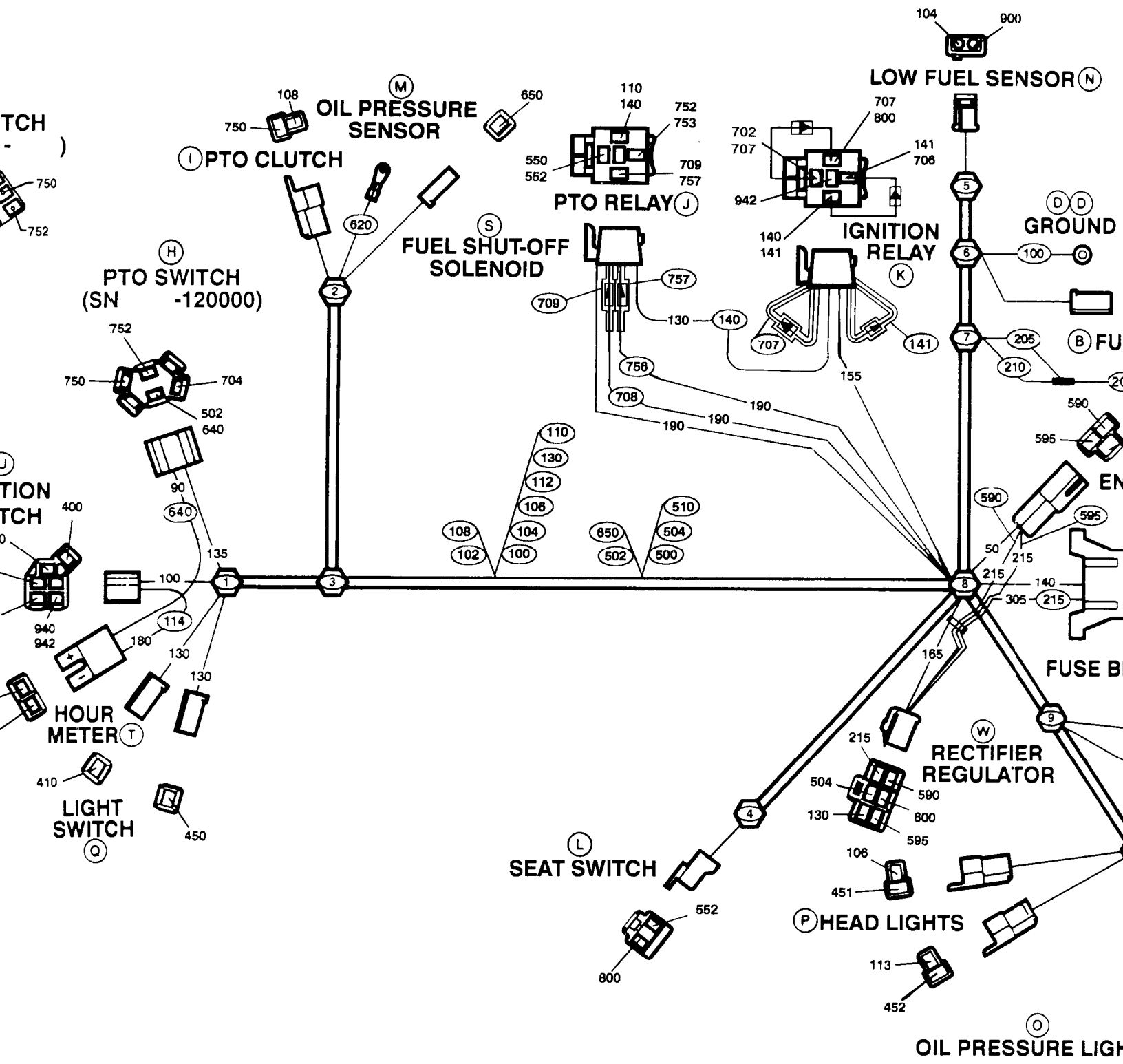

F510(100001-

) AND F525(100001-

) WIRING HARNESS

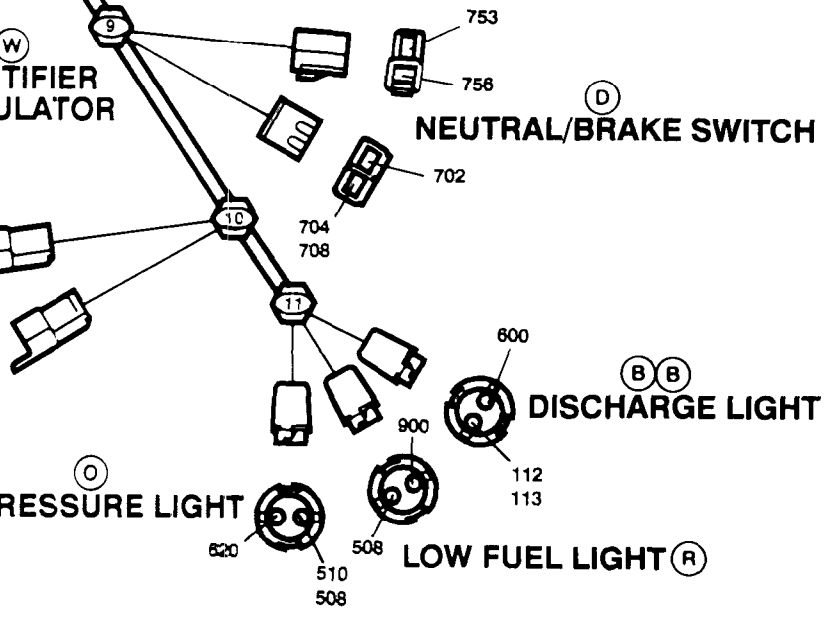
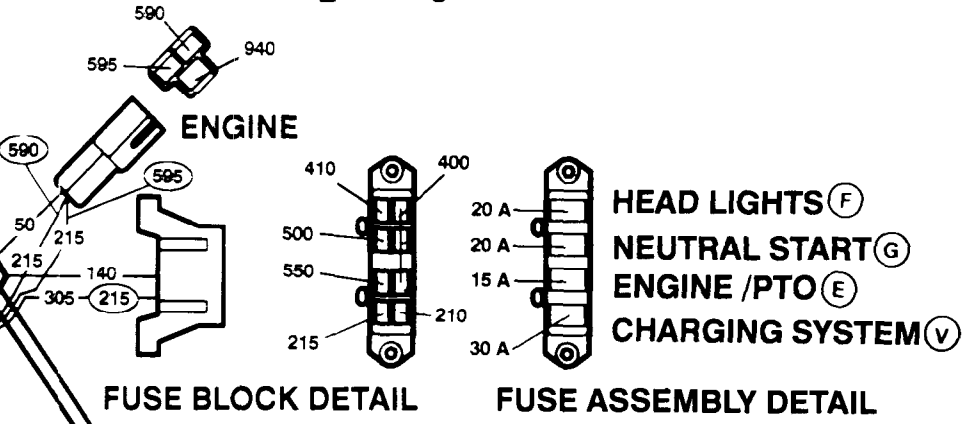
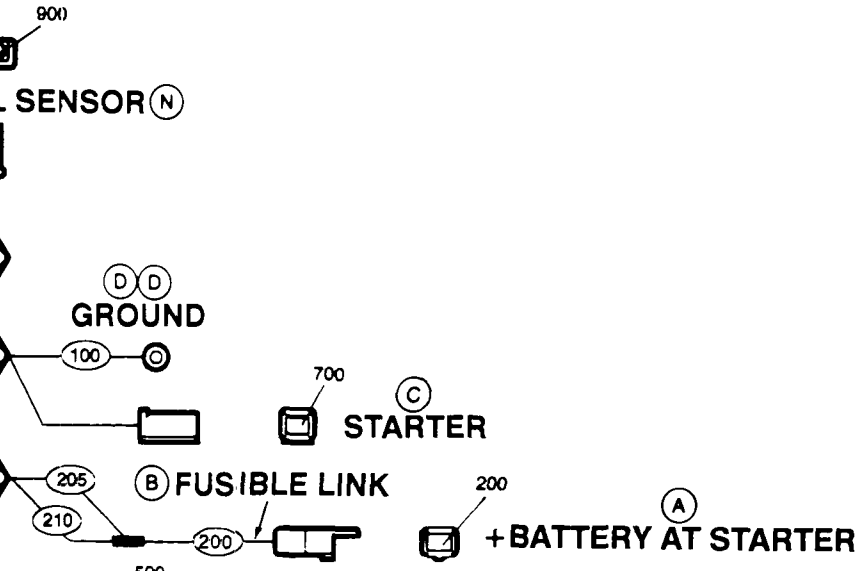

CIR NUM	WIRE SIZE mm ²	COLOR
100	2.0	blk
102	1.0	blk
104	1.0	blk
106	0.8	blk
108	1.0	blk
110	1.0	blk
112	0.8	blk
113	0.8	blk
114	0.8	blk
130	2.0	blk
140	1.0	blk
141	1.0	blk
142	1.0	blk/wht
200	1.0	red
205	3.0	red
210	3.0	red
215	2.0	red
400	3.0	yel/red
410	1.0	yel/blk
450	1.0	yel/wht
451	0.8	yel/wht
452	0.8	yel/wht
500	2.0	yel
502	1.0	yel/red
504	1.0	yel
508	0.8	yel
510	0.8	yel
550	1.0	yel
552	1.0	yel
590	3.0	brn/yel
595	3.0	brn/wht
600	0.8	brn
620	0.8	tan
640	0.8	yel
650	1.0	pnk/blk
700	1.0	pur
702	1.0	pur
704	1.0	pur
706	1.0	pur/blk
707	0.5	pur
708	1.0	pur/wht
709	0.8	pur or pur/wht
710	1.0	pur/wht
750	1.0	blu
752	1.0	blu/wht
753	1.0	blu
756	1.0	blu/wht
757	0.8	pur or pur/wht
800	1.0	pnk
900	0.8	blk/wht
940	1.0	wht
942	1.0	wht/blk

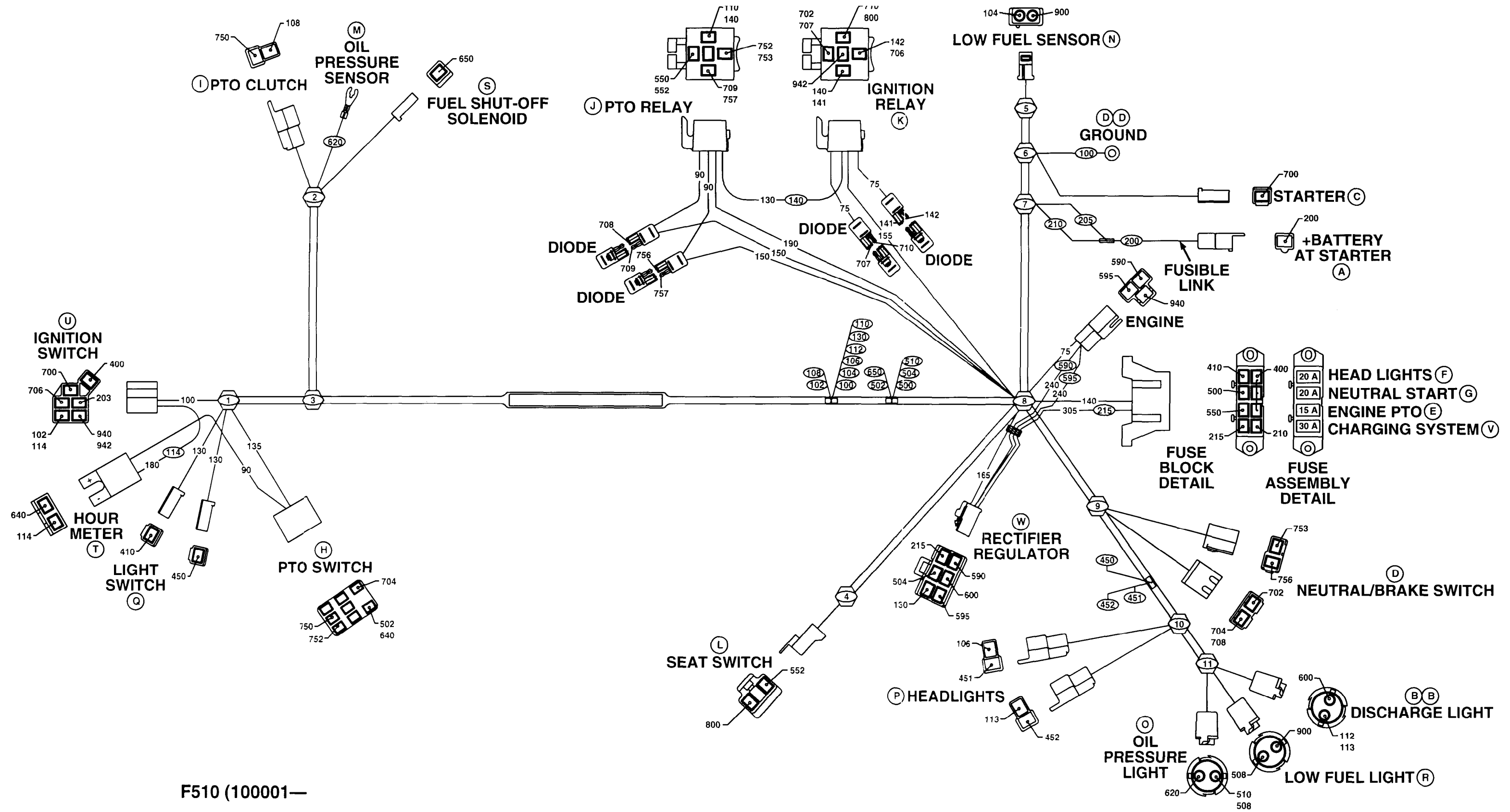

F510 (100001—

CIR NUM	WIRE SIZE mm ²	COLOR
100	2.0	blk
102	1.0	blk
104	1.0	blk
106	0.8	blk
108	1.0	blk
110	1.0	blk
112	0.8	blk
113	0.8	blk
114	0.8	blk
130	2.0	blk
140	1.0	blk
141	1.0	blk
142	1.0	blk/wht
200	1.0	red
205	3.0	red
210	3.0	red
215	2.0	red
400	3.0	yel/red
410	1.0	yel/blk
450	1.0	yel/wht
451	0.8	yel/wht
452	0.8	yel/wht
500	2.0	yel
502	1.0	yel/red
504	1.0	yel
508	0.8	yel
510	0.8	yel
550	1.0	yel
552	1.0	yel
590	3.0	brn/yel
595	3.0	brn/wht
600	0.8	brn
620	0.8	tan
640	0.8	yel
650	1.0	pnk/blk
700	1.0	pur
702	1.0	pur
704	1.0	pur
706	1.0	pur/blk
707	0.5	pur
708	1.0	pur/wht
709	0.8	pur or pur/wht
710	1.0	pur/wht
750	1.0	blu
752	1.0	blu/wht
753	1.0	blu
756	1.0	blu/wht
757	0.8	pur or pur/wht
800	1.0	pnk
900	0.8	blk/wht
940	1.0	wht
942	1.0	wht/blk

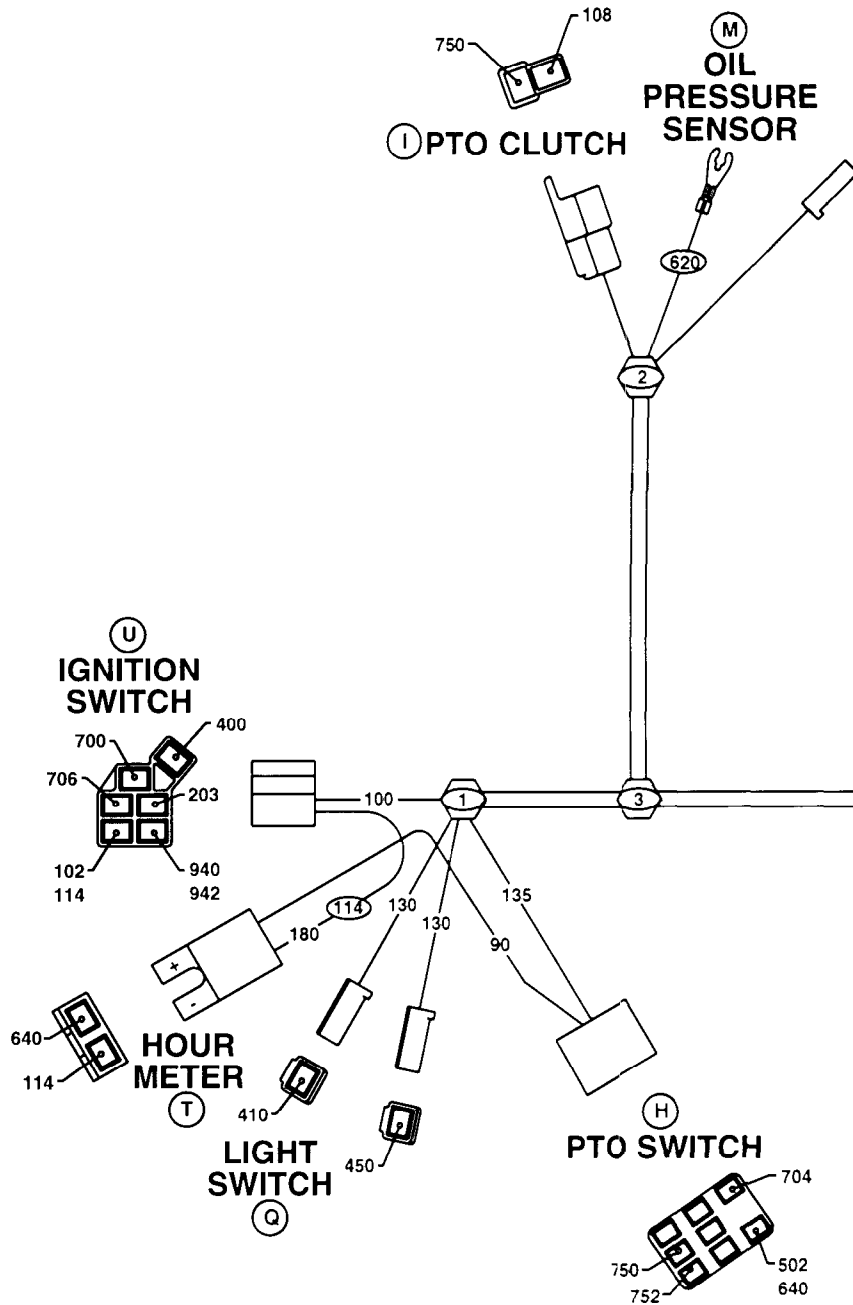

F510 (100001—



FUEL SENSOR (N)

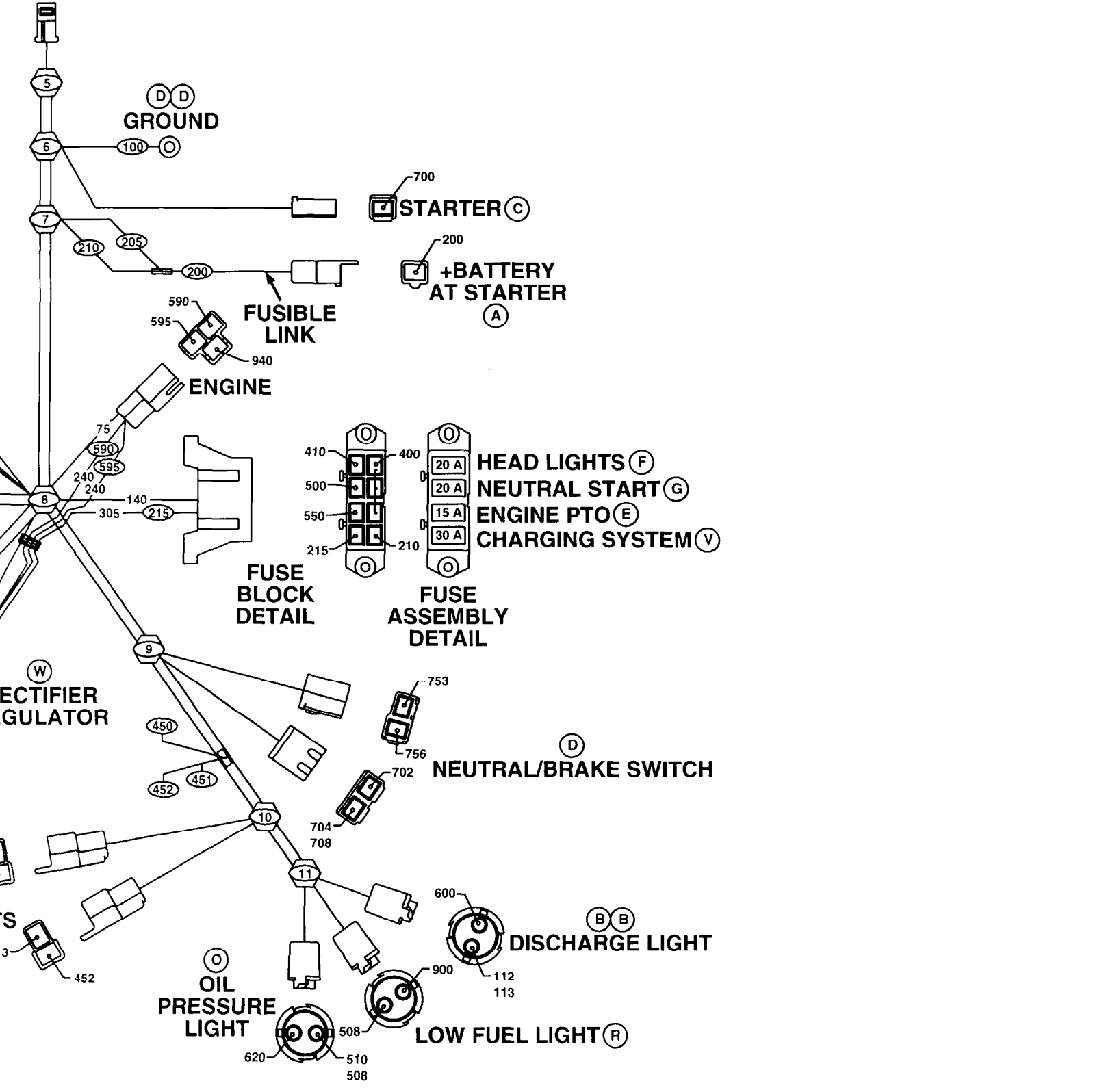

GROUND

STARTER (C)

+BATTERY AT STARTER (A)

FUSIBLE LINK

ENGINE

FUSE BLOCK DETAIL

FUSE ASSEMBLY DETAIL

HEAD LIGHTS (F)
NEUTRAL START (G)
ENGINE PTO (E)
CHARGING SYSTEM (V)

RECTIFIER REGULATOR (W)

NEUTRAL/BRAKE SWITCH (D)

DISCHARGE LIGHT (B B)

OIL PRESSURE LIGHT (O)

LOW FUEL LIGHT (R)

S

F510 AND F525 WIRING HARNESS WITH PLUG-IN DIODES (S.N. 100001—) LEGEND

A—Battery At Starter
B—Fuse Link
C—Starter Solenoid
D—Neutral/Brake Switch
E—Engine/PTO Fuse
F—Headlight Fuse
G—Neutral/Start Fuse

H—PTO Switch
I—PTO Clutch
J—PTO Relay
K—Ignition Relay
L—Seat Switch
M—Oil Pressure Sensor

N—Fuel Sensor
O—Oil Pressure Light
P—Headlights
Q—Light Switch
R—Low Fuel Light
S—Fuel Shutoff Solenoid

T—Hourmeter
U—Ignition Switch
V—Charge Fuse 30 Amp
W—Regulator/Rectifier
BB—Discharge Light
DD—Engine Ground

MX,24020CL,12 -19-23OCT95

240
20
13

240
20
14

Section 250

POWER TRAIN OPERATION, TESTS, AND ADJUSTMENTS

Contents

Page

Group 05—Power Train Component Location

Hydrostatic Transaxle	
Components—External View	250-05-1
Hydrostatic Charge and Piston Pump	
Housing Components	250-05-1
Hydrostatic Pump Components	
PA420A/PA540A-AS00 and BS00	250-05-2
PA420A/PA540A-AS01 and AS02	250-05-3
Hydrostatic Motor and Transaxle	
250-05-4	
Hydrostatic Motor Components	
250-05-5	
Transaxle Control Linkage	
250-05-6	

Group 10—Theory of Operation

Power Train Operation	
250-10-1	
Free-Wheeling Valve Operation	
250-10-2	
Hydrostatic Circuit Operation	
250-10-4	
Hydrostatic Circuit Operation	
Neutral	250-10-6
Forward	250-10-8
Reverse	250-10-10
Anti-cavitation Valve	250-10-12
Freewheel Valve	250-10-14
Freewheel Valve	250-10-16
Power Flow from the Motor	
250-10-18	
Gear Reduction Assembly Operation	
250-10-20	
Differential Operation	
250-10-22	

Group 15—Power Train Diagnosis

Lack of Drive or Limited Speed in Both	
Directions	250-15-2
Lack of Drive or Limited Speed in One	
Direction	250-15-4
Erratic Drive in Both Directions	
250-15-6	
Machine Creeps When in Neutral	
250-15-8	
Transmission Does Not Neutralize When	
the Brakes Are Applied	250-15-10
Directional Pedal Travel Adjustment	
250-15-12	
Directional Pedal—Neutral Adjustment	
250-15-13	
Neutral Return Linkage Adjustment	
250-15-14	
Control Valve Adjustment	
250-15-15	

250

HYDROSTATIC TRANSAXLE COMPONENTS—EXTERNAL VIEW

- A—Variable Displacement Hydrostatic Pump
- B—Axles
- C—Constant Displacement Motor
- D—Closed Loop Pressure Lines
- E—Planetary Reduction Drive
- F—Differential Gears
- G—Breather Pipe
- H—Corrugated Oil Return Line

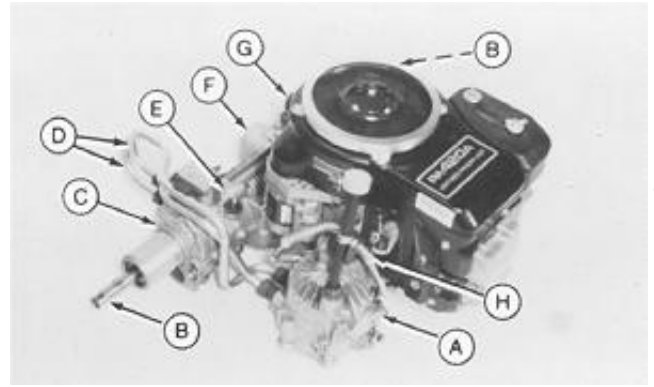

MX,25005CL,A1 -19-23OCT95

M53283 -UN-25AUG89

HYDROSTATIC CHARGE AND PISTON PUMP HOUSING COMPONENTS

- A—Camshaft Gear
- B—Pump Drive Gear
- C—Pump Shaft
- D—Gerotor Charge Pump
- E—Variable Displacement Piston Pump
- F—Swash Plate

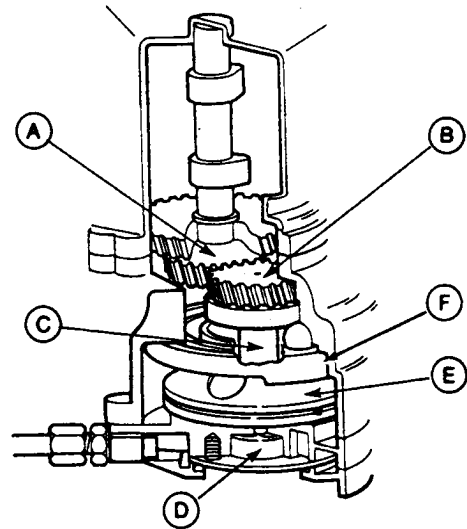

MX,25005CL,A4 -19-23OCT95

M52464 -UN-21AUG89

250
05
1

HYDROSTATIC PUMP COMPONENTS-PA420A/PA540A-AS00 AND BS00

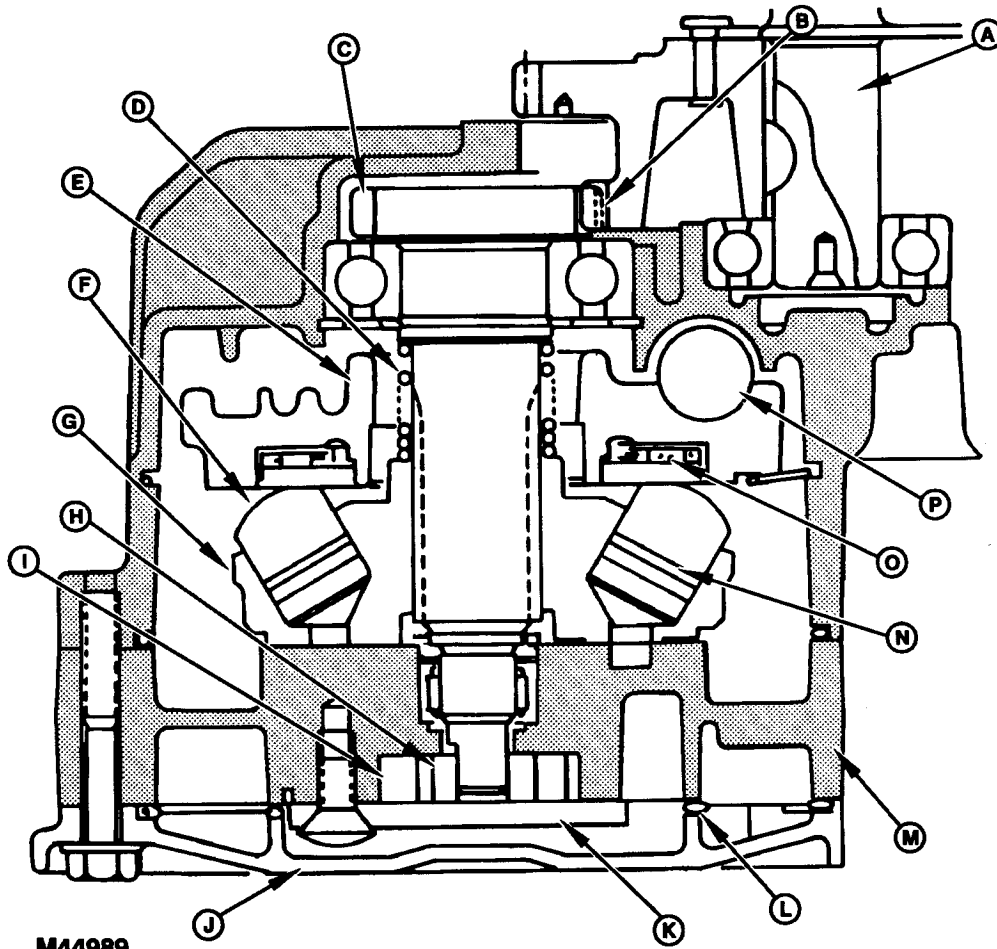

M44989

-JUN-22APR92

M44989

A—Engine Camshaft
 B—Camshaft Pump Drive
 Gear
 C—Pump Driven Gear
 D—Spring

E—Swash Plate
 F—Piston
 G—Cylinder Block
 H—Inner Charge Pump Rotor

I—Outer Charge Pump Rotor
 J—Pump Cover
 K—Charge Pump Plate
 L—Charge Pump Screen

M—Pump Housing
 N—Piston Ring
 O—Needle Thrust Bearing
 P—Swash Plate Pivot Ball

MX,25005CL,A2 -19-23OCT95

HYDROSTATIC PUMP COMPONENTS-PA420A/PA540A-AS01 AND AS02

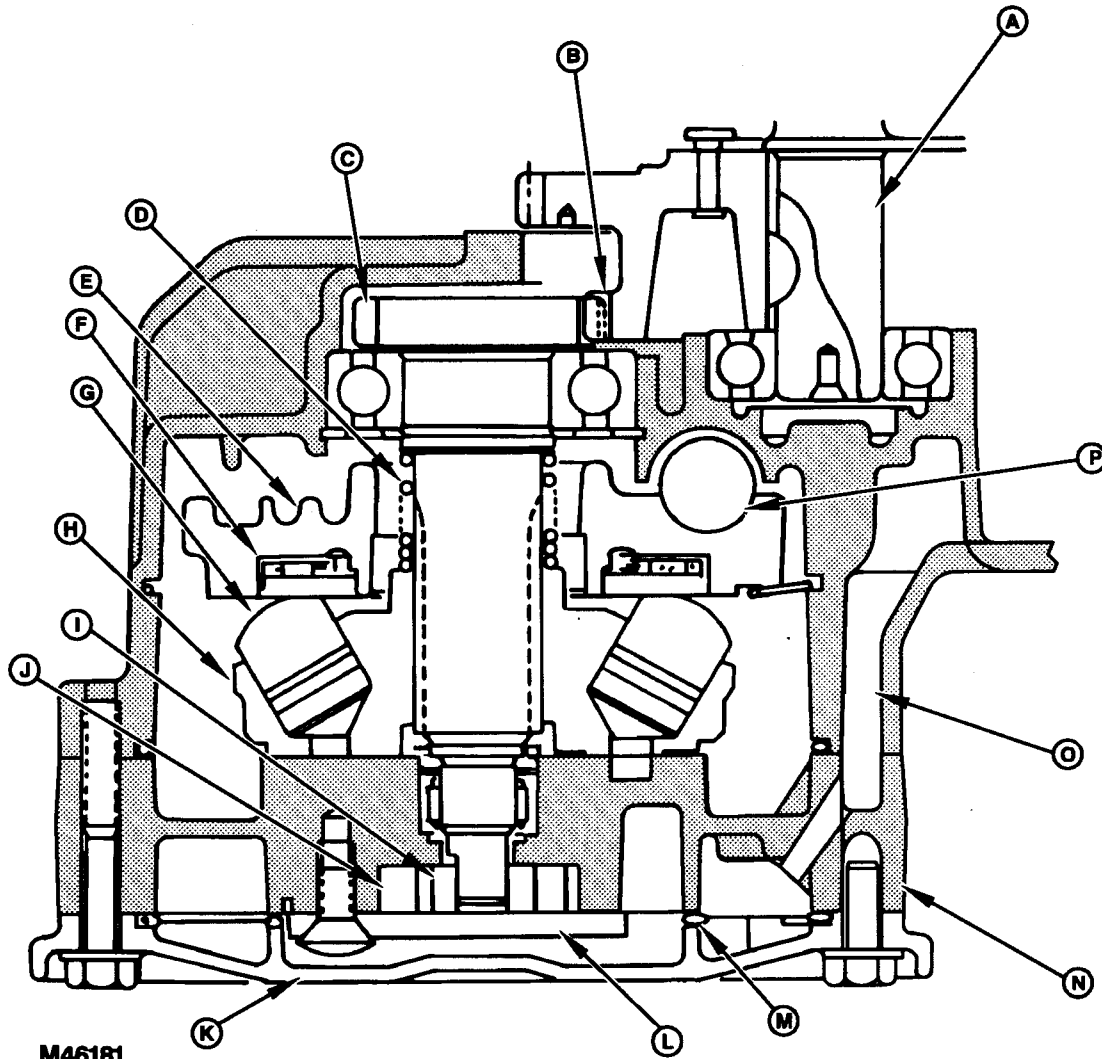

M46181

- | | | | |
|----------------------------|-------------------------|---------------------------|--------------------------|
| A—Engine Camshaft | E—Swash Plate | I—Inner Charge Pump Rotor | M—Charge Pump Screen |
| B—Camshaft Pump Drive Gear | F—Needle Thrust Bearing | J—Outer Charge Pump Rotor | N—Pump Housing |
| C—Pump Driven Gear | G—Piston | K—Pump Cover | O—Internal Oil Passage |
| D—Spring | H—Cylinder Block | L—Charge Pump Plate | P—Swash Plate Pivot Ball |

250
05
3

M46181 -JUN-27/APR92

MX,25005CL,A2A -19-23OCT95

HYDROSTATIC MOTOR AND TRANSAXLE COMPONENTS

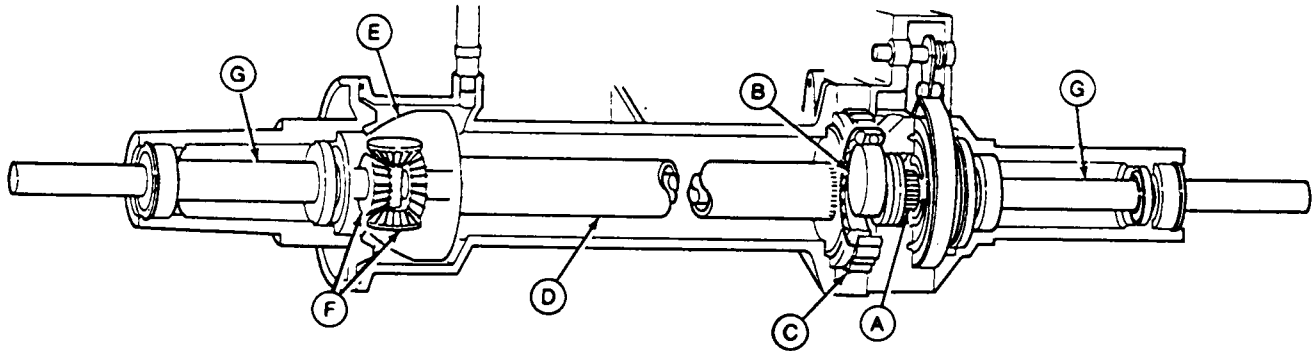

A—Motor Input Shaft
B—Eccentric

C—Cycloid Gear
D—Splined Shaft

E—Differential Carrier
F—Differential Spur Gears

G—Axles

MX,25005CL,A5 -19-23OCT95

250
05
4

M53153 -UN-21AUG89

HYDROSTATIC MOTOR COMPONENTS

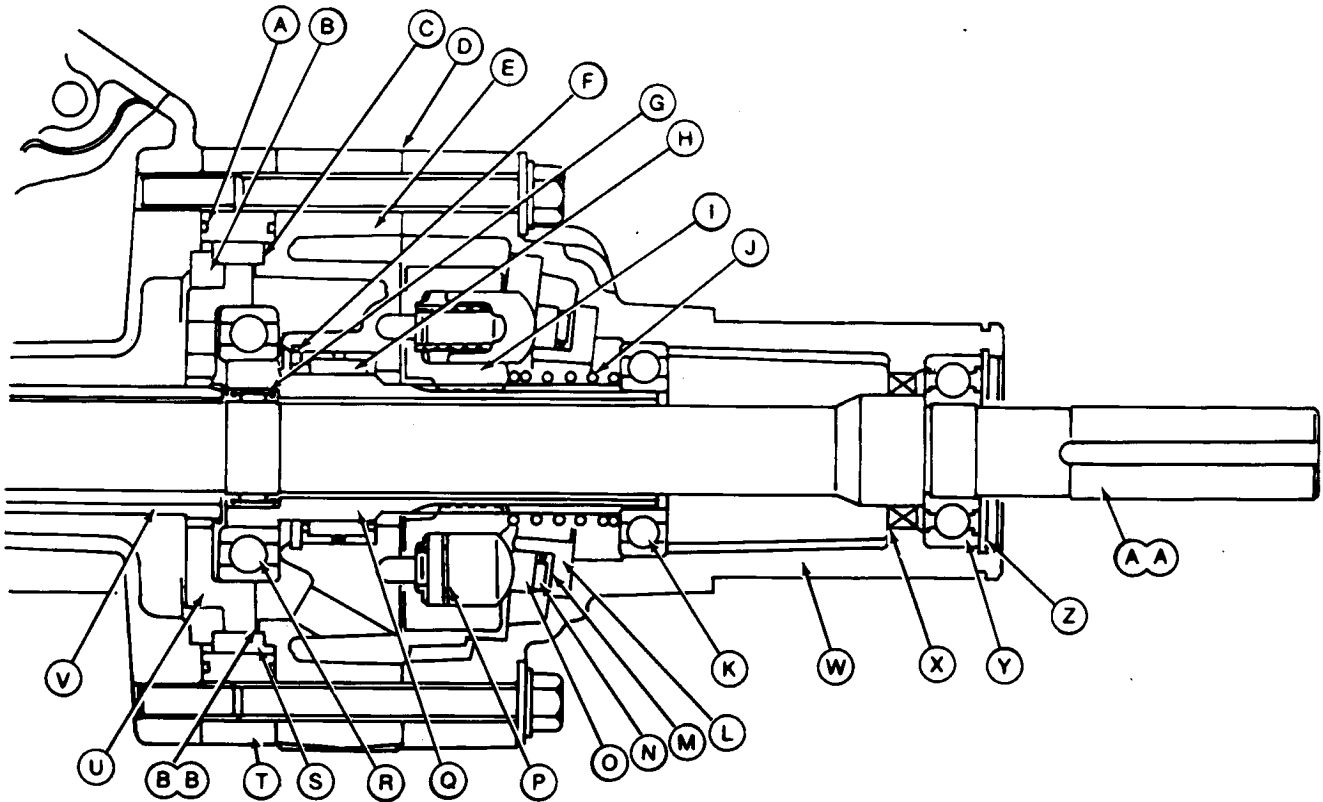

- | | | | |
|------------------------------------------------|-------------------------------------------------|-------------------------|-----------------------------|
| A—O-Ring | H—Needle Bearing | N—Needle Thrust Bearing | V—Transmission Output Shaft |
| B—Spacer | I—Motor Cylinder | O—Thrust Plate | W—Axle Housing |
| C—Spacer | J—Spring (Not Used PA420A/PA540A-AS01 and AS02) | P—Piston and O-Ring | X—Oil Seal |
| D—Gasket | K—Ball Bearing | Q—Input Shaft-Motor | Y—Shield Bearing |
| E—Motor Housing | L—Spacer | R—Ball Bearing | Z—Snap Ring |
| F—Snap Ring | M—Thrust Plate | S—Rollers | AA—Axle-Left |
| G—Needle Bearing (Not Used PA420A/PA540A-AS01) | | T—Case | BB—Spacer |
| | | U—Internal Cycloid Gear | |

M53285 -UN-21AUG89

MX,25005CL,A3 -19-23OCT95

TRANSAXLE CONTROL LINKAGE COMPONENTS

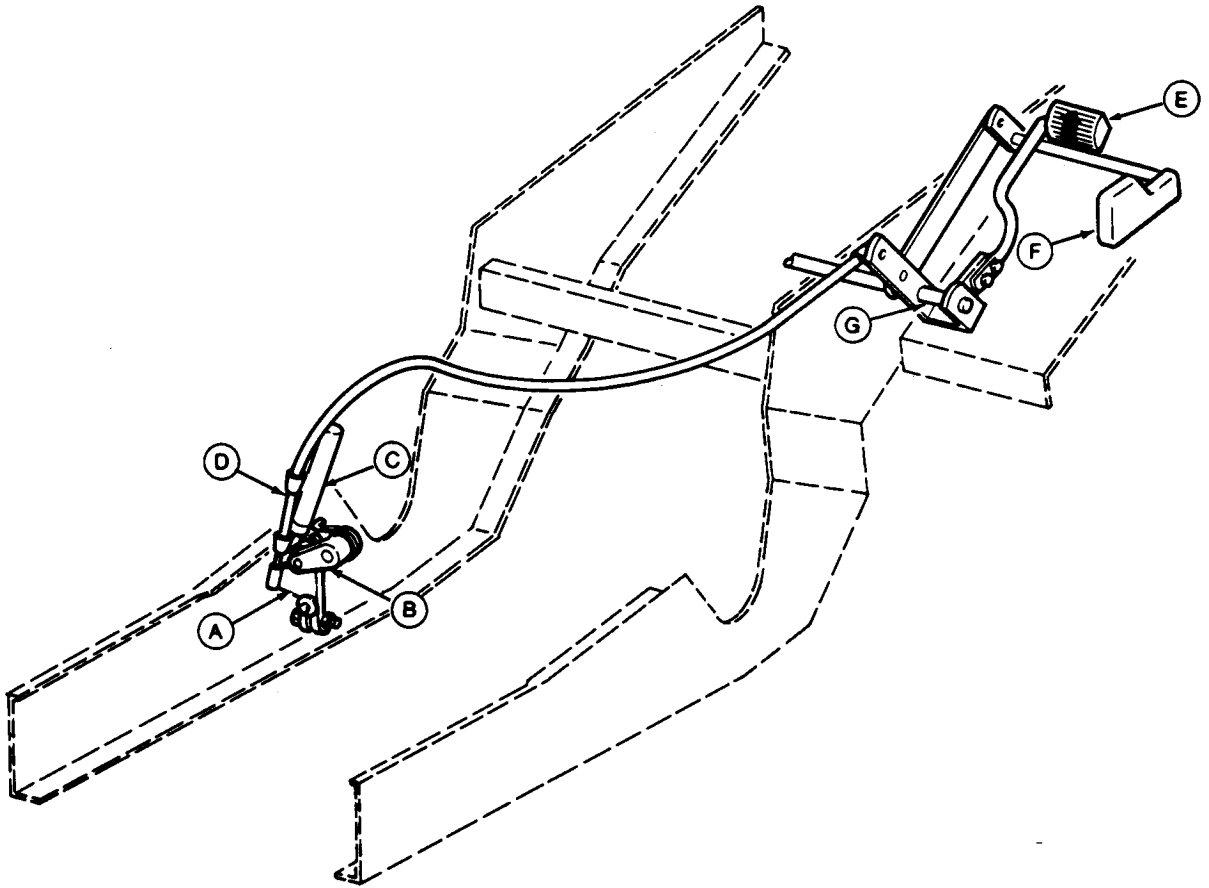

A—Swash Plate Control Arm
B—Cam Follower

C—Shock Absorber
D—Cable

E—Forward Pedal
F—Reverse Pedal

G—Pedal Pivot Shaft

250
05
6

M53304 -UN-21AUG89

MX,25005CL,A6 -19-23OCT95

POWER TRAIN

The power flow from the engine is identical for both the F510 and the F525. The engine camshaft has two gears. The upper one drives the camshaft, and the lower gear (A) mates with and drives the transmission pump shaft gear (B). The pump shaft (C) is splined to and drives the hydrostatic pump rotating group.

Pump shaft (C) also extends through the pump rotating group and a tang on the end of the shaft drives the hydrostatic transmission charge pump (D).

The transmission pump (E) is an inclined piston design. There are no slippers on the pistons, the pistons ride directly on a thrust washer and bearing that is staked in place in the movable swash plate.

The charge pump is gerotor design. Its sole function is to supply make-up oil to the closed loop.

- A—Camshaft Gear
- B—Pump Shaft Gear
- C—Pump Shaft
- D—Gerotor Charge Pump
- E—Variable Displacement Pump
- F—Swash Plate
- G—Power Flow From Engine To Charge Pump

Ⓒ POWERFLOW FROM ENGINE TO CHARGE PUMP

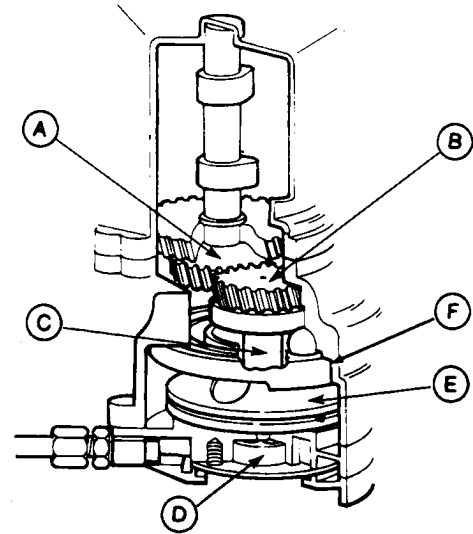

MX,25010CL,A1 -19-23OCT95

250
10

-JUN-21AUG89

M53305

FREE-WHEELING VALVE OPERATION

Pushing down on push rod (A) will align orifices (C) and (D). Oil from the hydrostatic motor can then circulate through the passage formed by orifices (C), (D), and (E), allowing the front mower to be pushed with the engine not operating.

When pressure on the push rod is released, spring (B) returns the valve to the position shown. This prevents free circulation of oil through the motor.

- A—Push Rod
- B—Spring
- C—Poppet Orifice
- D—Valve Body Orifice
- E—Poppet Orifice

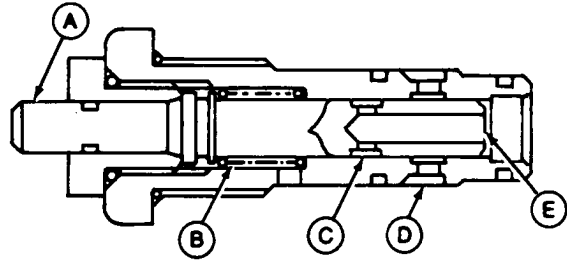

M53306 -UN-21/AUG89

250
10
2

MX,25010CL,A2 -19-23OCT95

250
10
3

HYDROSTATIC CIRCUIT OPERATION

A—Reduction Gear Assembly
 B—Hydrostatic Motor
 C—Charge Relief Valve
 D—Directional Check Valves
 E—Free-Wheel Valve

F—Gerotor Charge Pump
 G—External High Pressure Lines
 H—Hydrostatic Pump
 I—Engine

J—Engine Sump
 K1—External Suction Line (—110000)
 K2—Internal Suction Passage (110001—)

L—Filter Screens
 M—Charge Pump Sump
 N—Anti-Cavitation Check Valve
 O—External Return Line

Function:

The hydrostatic circuit transfers power from the gerotor charge pump (F) to the variable displacement hydrostatic pump (H) to the fixed displacement hydrostatic motor (B). The motor transfers power to the input shaft of the reduction gear assembly, allowing infinitely variable speeds in forward and reverse.

Theory of Operation:

The hydrostatic circuit consists of the following components:

A—Reduction Gear Assembly - Transfers power from the hydrostatic motor to the differential.

B—Hydrostatic Motor - Transmits power to the gear reduction assembly. The motor is a bi-directional, fixed displacement, axial piston motor.

C—Charge Relief Valve - Maintains a charge pressure of 193—490 kPa (28—71 psi), also maintains needed pressure for make-up oil and lubrication. Excessive charge pressure oil is relieved to the hydrostatic pump side of the common sump.

D—Directional Check Valve - These one-way valves perform two functions in the closed-loop circuit:

1. On the high pressure side the valve prevents high-pressure oil from flowing to the low-pressure side.
2. On the low-pressure side the valve allows charge pump oil to replenish and lubricate the components of the closed loop.

E—Free-wheel Valve - This valve allows oil to bypass the hydrostatic pump (H) when the unit is moved without the engine running. The freewheel valve connects both sides of the closed loop to prevent pressure build up from the hydrostatic motor (B) as it is turned by the differential when unit is being pushed.

F—Gerotor Charge Pump - Supplies charge (make-up) oil to the hydrostatic closed loop to prevent cavitation of the hydrostatic pump (H). The charge

pump is a gerotor type, fixed displacement pump. It continually pumps oil whenever the engine is running.

G—External High Pressure Lines - These external closed loop lines connect the hydrostatic pump (H) to the motor (B).

H—Hydrostatic Pump - This pump supplies high pressure oil to the hydrostatic motor (B). It is a variable displacement, axial piston pump. The output of the pump (speed and direction) is varied by moving the swash plate via the pedal shift linkages.

I—Engine - Supplies power to the hydrostatic pump input shaft via the second gear on the camshaft.

J—Engine Sump - Oil reservoir for the hydrostatic transmission.

K1—External Suction Line (—110000) - The suction line is an external line that supplies and cools oil to the charge pump sump.

K2—Internal Suction Passage (110001—) - The internal suction passage replaces the external line that supplies oil to the charge pump sump. The internal passage is located in the bottom of the case cover and travels through the hydrostatic pump housing to the charge pump sump (M).

L—Filter Screens - Remove debris from the oil prior to entering the engine and hydrostatic gerotor charge pumps.

M—Charge Pump Sump - Oil reservoir for the charge pump (F).

N—Anti-Cavitation Check Valve - Allows oil to enter the closed loop through the charge circuit to replace oil lost from motor (B) leakage when the freewheel valve (E) is used. This prevents the hydrostatic pump (H) from cavitating at initial startup.

O—External Return Line - Allows excess oil inside the motor housing (B) to flow to the engine sump. This oil is used to cool and lubricate the rotating groups of the reduction gear assembly (A).

250
10
4

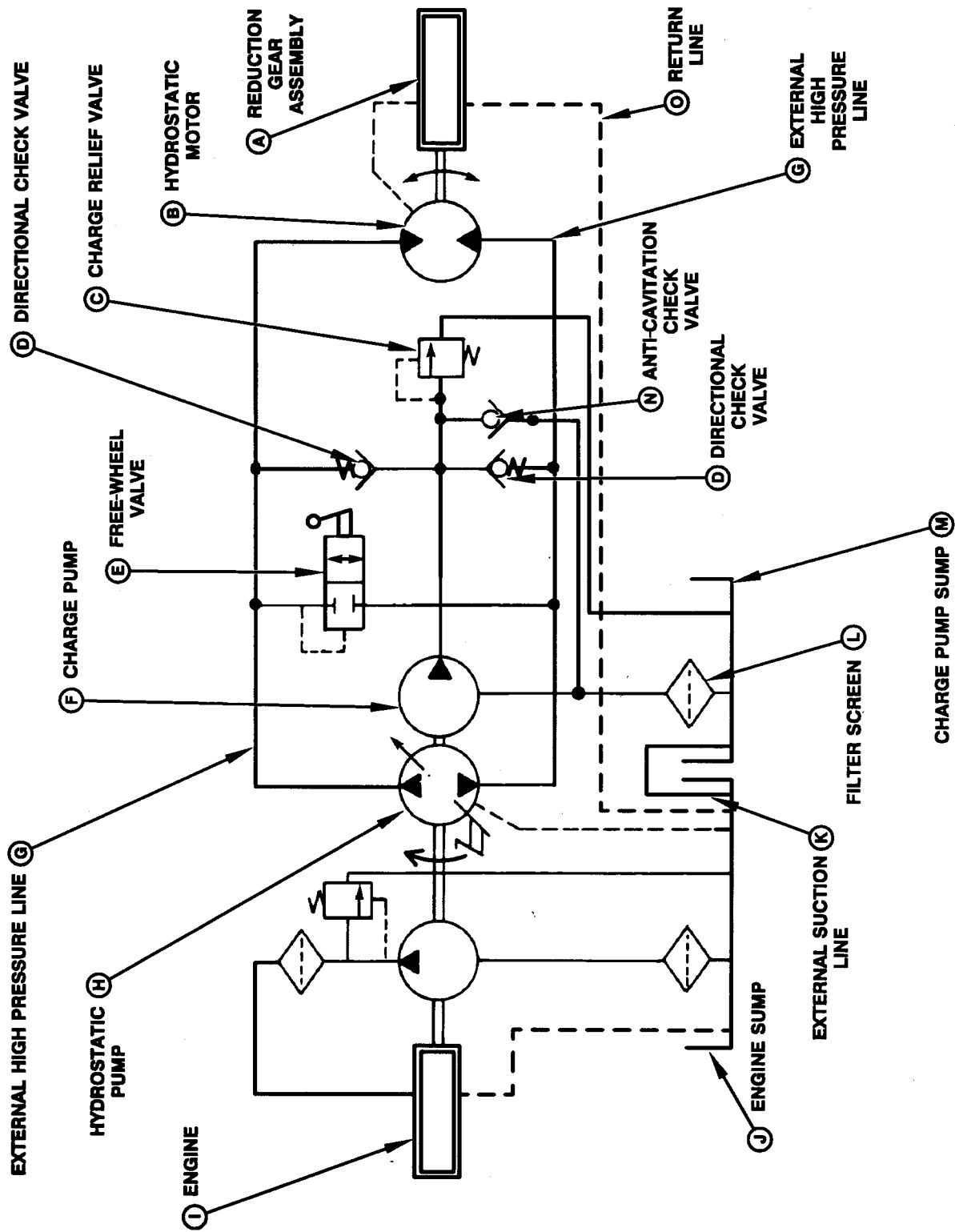

HYDROSTATIC CIRCUIT OPERATION

M46189 -19-01MAY92

250

HYDROSTATIC CIRCUIT OPERATION—NEUTRAL

A—Reduction Gear Assembly	G—External High Pressure Lines	K2—Internal Suction Passage (110001—)	O—External Return Line
B—Hydrostatic Motor	H—Hydrostatic Pump	L—Filter Screens	P—Charge Pressure Oil
C—Charge Relief Valve	I—Engine	M—Charge Pump Sump	Q—Return Oil
D—Directional Check Valves	J—Engine Sump	N—Anti-Cavitation Check Valve	
E—Free-Wheel Valve	K1—External Suction Line (—110000)		
F—Gerotor Charge pump			

When the transmission is in neutral and the engine running, the gerotor charge pump (F) draws oil from the charge pump sump (M) through filter screen (L). Charge oil pressure (P) closes the freewheeling valve (E). With the swash plate in the neutral position, the hydrostatic pump (H) pistons do not create pressure on either side of the closed loop (external high pressure lines (G)). With no high pressure to hold the check valves (D) closed, both check valves open and charge oil flows to both sides of the closed loop. Since the charge pressure on both sides of the

closed loop is equal, the hydrostatic motor (B) does not turn. As charge oil pressure increases and overcomes the charge relief spring, the charge relief valve (C) opens. This allows excess charge oil to flow to the charge pump sump. The charge relief valve maintains charge pressure at 193-490 kPa (28-71 psi). Normal leakage from the motor (B) gradually fills the motor housing, which helps to cool and lubricate the motor. When the motor housing is full, return oil flows back to the engine sump (J) through an external return line (O).

250
10
6

MX,25010CL,A6 -19-23OCT95

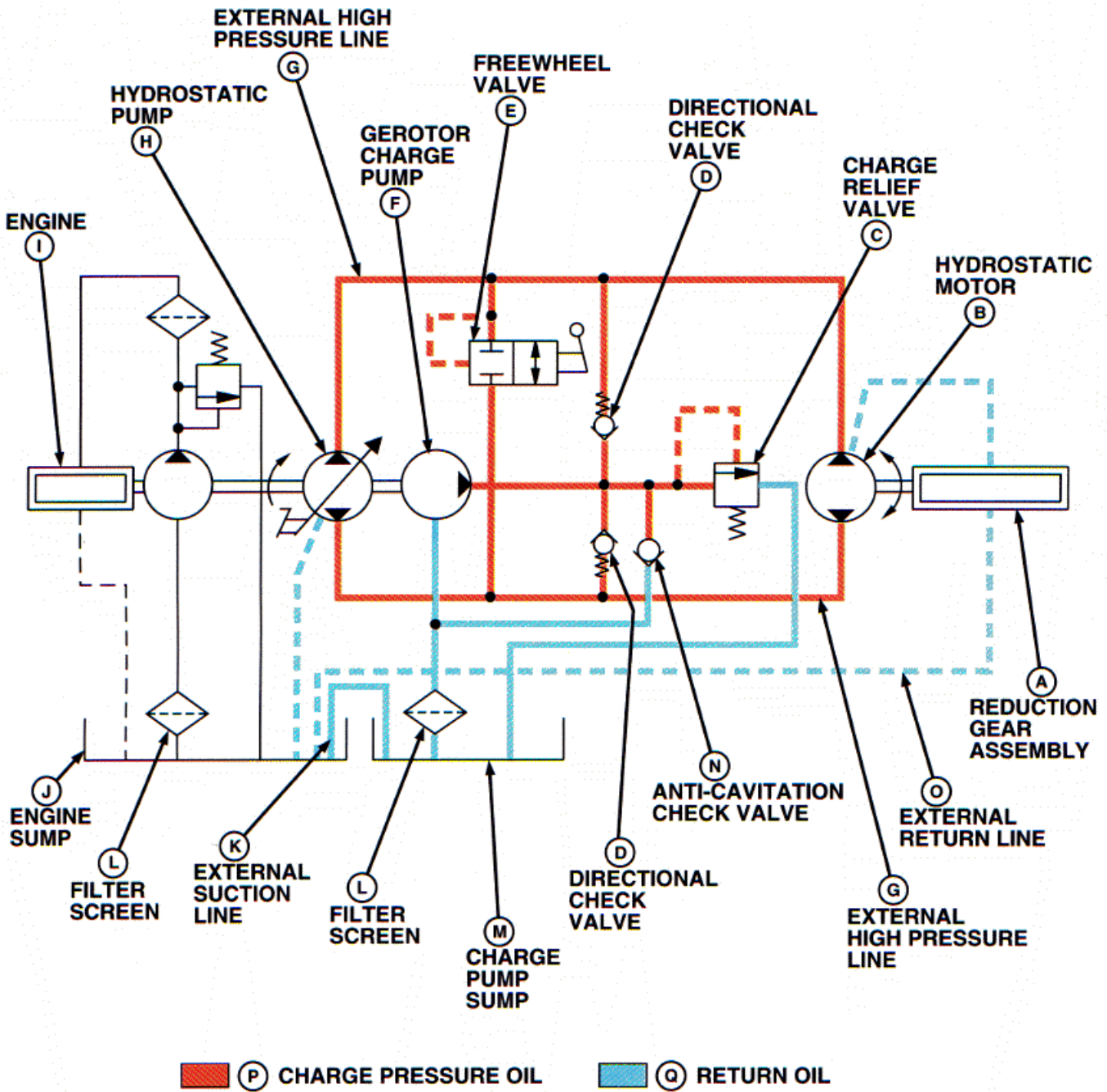

250
10
7

MXC44984

HYDROSTATIC CIRCUIT OPERATION - NEUTRAL

MXC44984 -JUN-

FORWARD OPERATION

A—Reduction Gear Assembly	G—External High Pressure Lines	K2—Internal Suction Passage (110001—)	O—External Return Line
B—Hydrostatic Motor	H—Hydrostatic Pump	L—Filter Screens	P—Directional Check Valve (High Pressure Side)
C—Charge Relief Valve	I—Engine	M—Charge Pump Sump	Q—High Pressure Oil
D—Directional Check Valve (Low Pressure Side)	J—Engine Sump	N—Anti-Cavitation Check Valve	R—Charge Pressure Oil
E—Free-Wheel Valve	K1—External Suction Line (—110000)		S—Return Oil
F—Gerotor Charge Pump			

When the transmission control pedal is moved to the forward position, mechanical linkage moves the hydrostatic pump (H) swash plate for forward operation. With the swash plate angled, the pump pistons do not have equal displacement and are forced to pump oil on one side of the closed loop. This results in high pressure oil (Q) flowing on that side of the closed loop. High pressure oil closes the check valve (P) in that closed loop and forces oil to the intake side of the hydrostatic motor (B). High pressure oil acting against the motor pistons forces the piston to extend, which causes the motor to rotate on its fixed displacement swashplate and drive the reduction gear assembly (A). Oil from the outlet side of the motor returns to the pump on the low

pressure side of the closed loop. Any oil lost due to leakage of the pump and motor is replaced through the check valve (D) in the low pressure side of closed loop.

Excess charge oil is relieved to the charge pump sump (M) through the charge relief valve (C). The freewheel valve (E) is held closed by charge pressure acting against the valve.

Normal leakage from the hydrostatic pump (H) and motor (B) becomes return oil (S) and is returned to the engine sump (J) via an internal return passage for the pump and an external return line (O) for the motor.

250
10
8

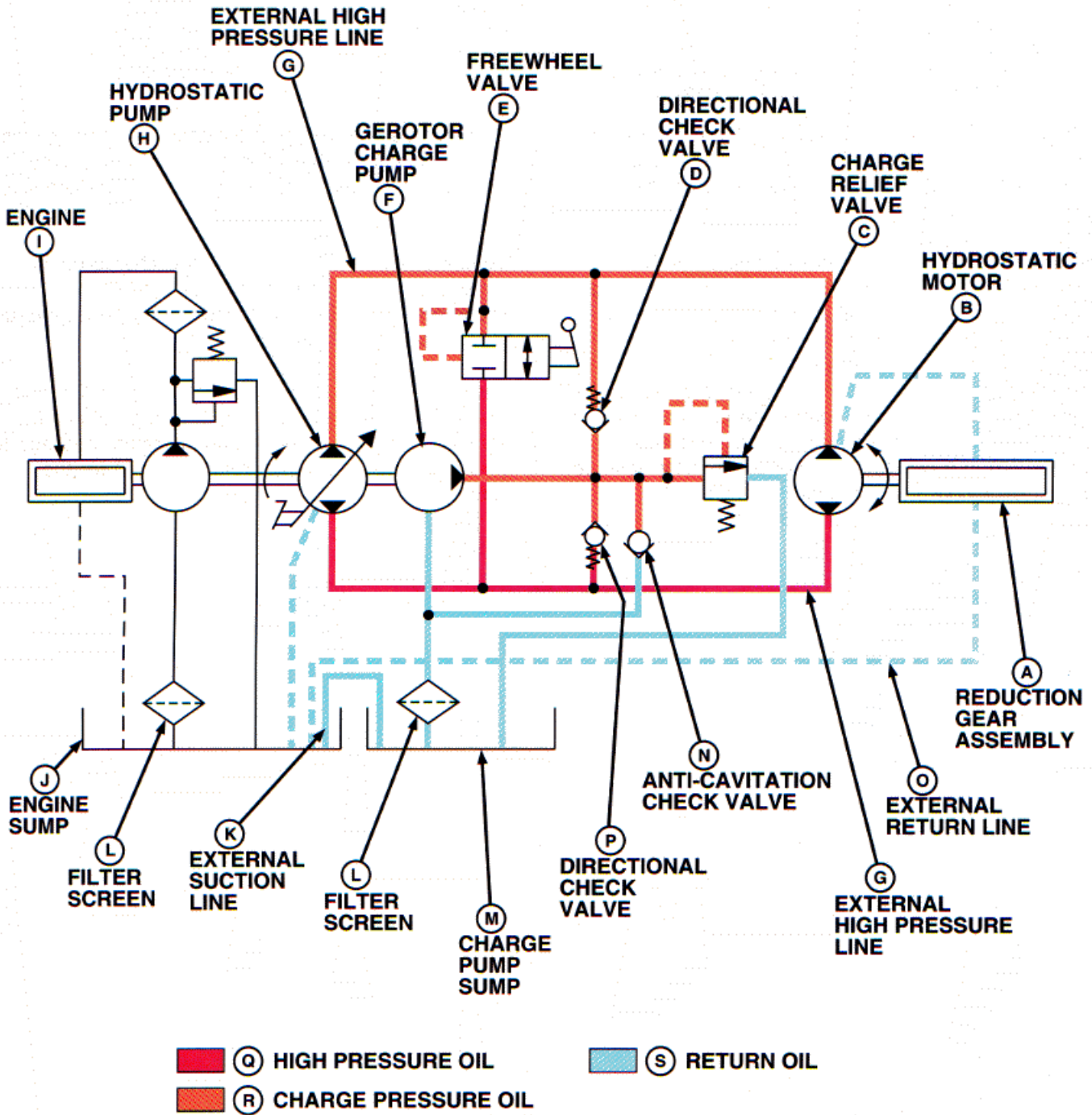

250
10
9

HYDROSTATIC CIRCUIT OPERATION - FORWARD

MXC44985

MXC44985 -UN-

REVERSE OPERATION

A—Reduction Gear Assembly	G—External High Pressure Lines	K2—Internal Suction Passage (110001—)	O—External Return Line
B—Hydrostatic Motor	H—Hydrostatic Pump	L—Filter Screens	P—Directional Check Valve (Low Pressure Side)
C—Charge Relief Valve	I—Engine	M—Charge Pump Sump	Q—High Pressure Oil
D—Directional Check Valve (High Pressure Side)	J—Engine Sump	N—Anti-Cavitation Check Valve	R—Charge Pressure Oil
E—Free-Wheel Valve	K1—External Suction Line (—110000)		S—Return Oil
F—Gerotor Charge Pump			

When the transmission control pedal is moved to the reverse position, mechanical linkage moves the hydrostatic pump (H) swash plate in the opposite direction for reverse operation. With the swash plate angled, the pump pistons do not have equal displacement and are forced to pump oil on the opposite side of the closed loop. This results in high pressure oil (Q) flowing on that side of the closed loop. High pressure oil closes the check valve (D) in that closed loop and forces oil to the intake side of the hydrostatic motor (B). High pressure oil acting against the motor pistons forces the piston to extend. Since the motor is receiving oil from the opposite direction from forward, the motor turns in the reverse direction, driving the differential in reverse. Oil from the outlet side of the motor returns to the pump on

the low pressure side of the closed loop. Any oil lost due to leakage of the pump and motor is replaced through the check valve (P) in the low pressure side of closed loop.

Excess charge oil is relieved to the charge pump sump through the charge relief valve (C). The freewheel valve (E) is held closed by charge pressure acting against the valve.

Normal leakage from the hydrostatic pump (H) and motor (B) becomes return oil (S) and is returned to the engine sump (J) via an internal return passage for the pump and an external return line (O) for the motor.

250
10
10

MX,25010CL,A10 -19-23OCT95

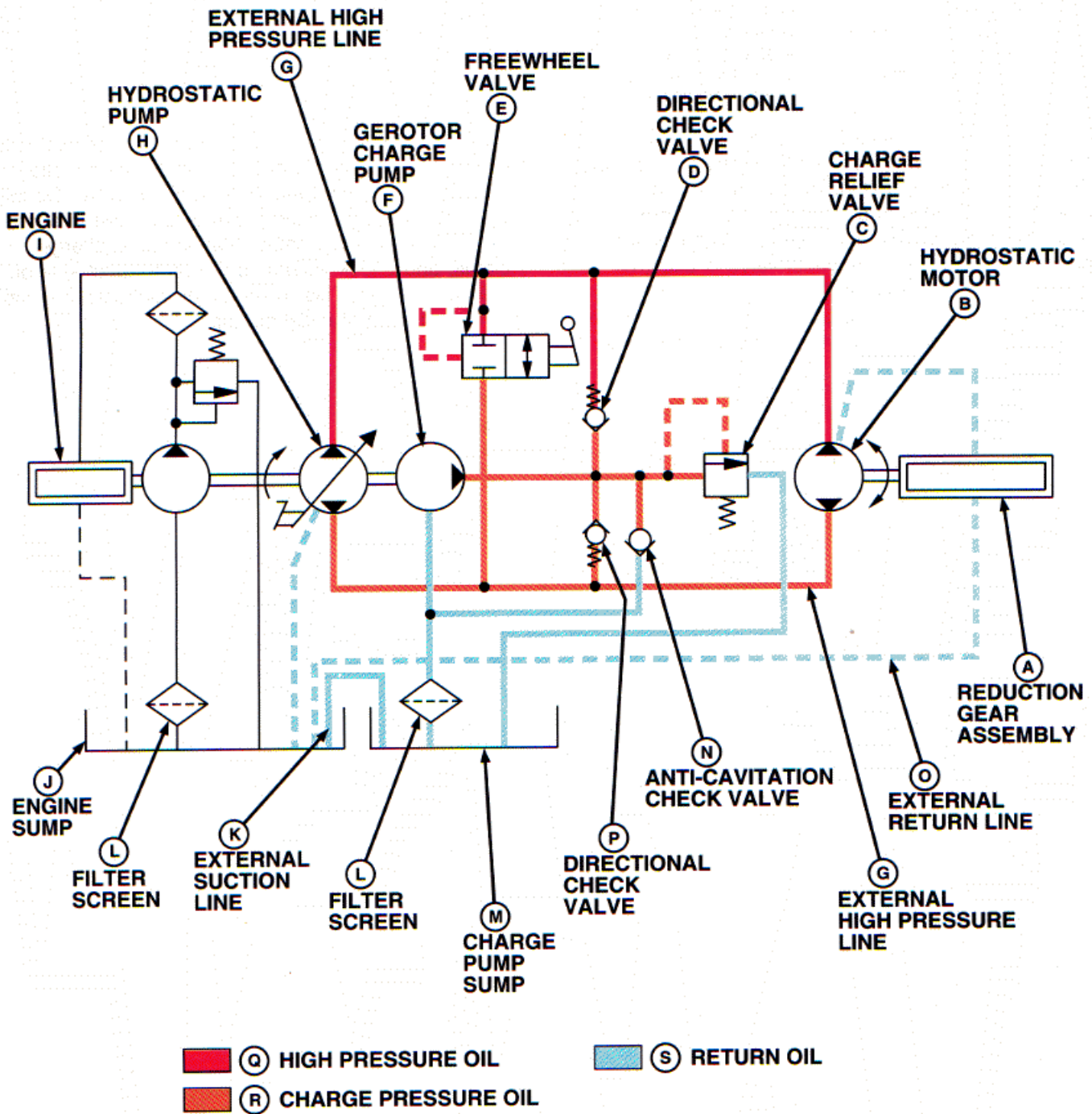

250
10
11

MXC44986

HYDROSTATIC CIRCUIT OPERATION - REVERSE

-JUN-
MXC44986

MX,25010CL,A11 -19-23OCT95

ANTI-CAVITATION VALVE OPERATION

A—Reduction Gear Assembly	G—External High Pressure Lines	K2—Internal Suction Passage (110001—)	O—External Return Line
B—Hydrostatic Motor	H—Hydrostatic Pump	L—Filter Screens	P—Low Pressure Oil
C—Charge Relief Valve	I—Engine	M—Charge Pump Sump	Q—Return Oil
D—Directional Check Valves	J—Engine Sump	N—Anti-Cavitation Check Valve	R—Suction Oil
E—Free-Wheel Valve	K1—External Suction Line (—110000)		
F—Gerotor Charge pump			

The anti-cavitation valve (N) allows oil to enter the closed loop to replace oil lost from hydrostatic motor (B) when the freewheel valve (E) is used. The anti-cavitation valve is connected to the charge circuit passage to the suction side of the gerotor charge pump (F). When the free-wheel valve is used, oil leakage from the motor will cause the closed loop to lose oil. With the engine stopped, the charge pump cannot supply make-up oil to the closed loop. This

creates a vacuum in the closed loop at the inlet side of the motor. This will open the inlet side directional check valve (D) and the anti-cavitation valve. Oil will be drawn from the charge pump sump (M) through the filter screen (L), anti-cavitation valve, charge circuit, and check valve into the motor inlet side of the closed loop. This prevents the hydrostatic pump from cavitating at initial startup.

250
10
12

MX,25010CL,20 -19-23OCT95

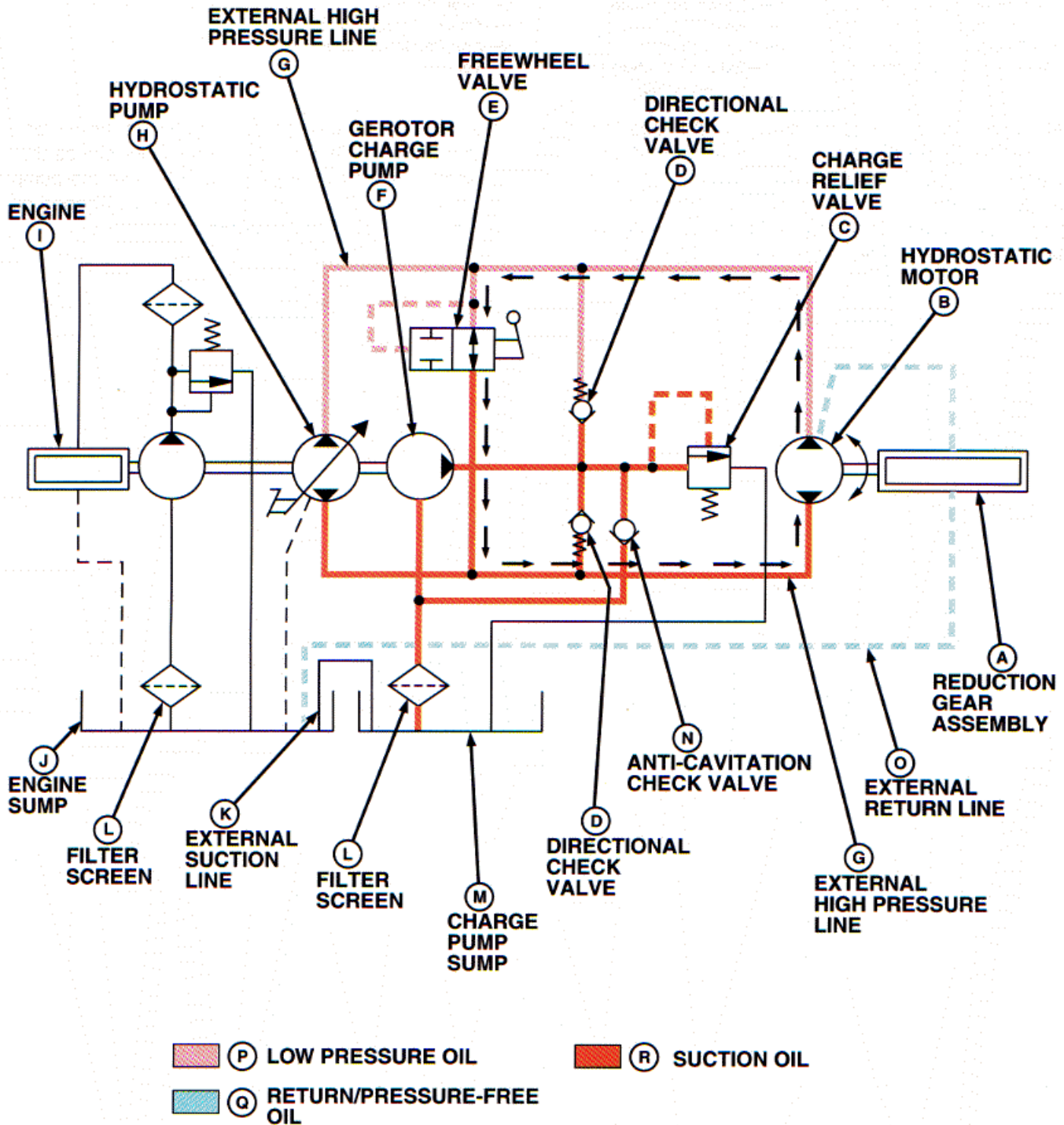

ANTI-CAVITATION VALVE OPERATION

MC83019

250
10
13

MC83019 -19

FREEWHEEL VALVE OPERATION—PRE-ENGAGEMENT

A—Reduction Gear Assembly	G—External High Pressure Lines	K2—Internal Suction Passage (110001—)	O—External Return Line
B—Hydrostatic Motor	H—Hydrostatic Pump	L—Filter Screens	P—Low Pressure Oil
C—Charge Relief Valve	I—Engine	M—Charge Pump Sump	Q—Trapped Oil
D—Directional Check Valves	J—Engine Sump	N—Anti-Cavitation Check Valve	
E—Free-Wheel Valve	K1—External Suction Line (—110000)		
F—Gerotor Charge pump			

When the engine is off, the pump shaft keeps the hydrostatic pump (H) cylinder block from rotating even with pressure applied to the pump pistons. If the unit is pushed, the differential will cause the hydrostatic motor (B) to rotate. Since the motor plate has a fixed incline, the motor becomes a pump momentarily,

building pressure between the motor and the pump. This immediate pressure closes the directional check valves (D) and because the pump cannot rotate, the pressure oil becomes trapped oil (Q) and the unit cannot be pushed (locks-up).

250
10
14

MX,25010CL,16 -19-23OCT95

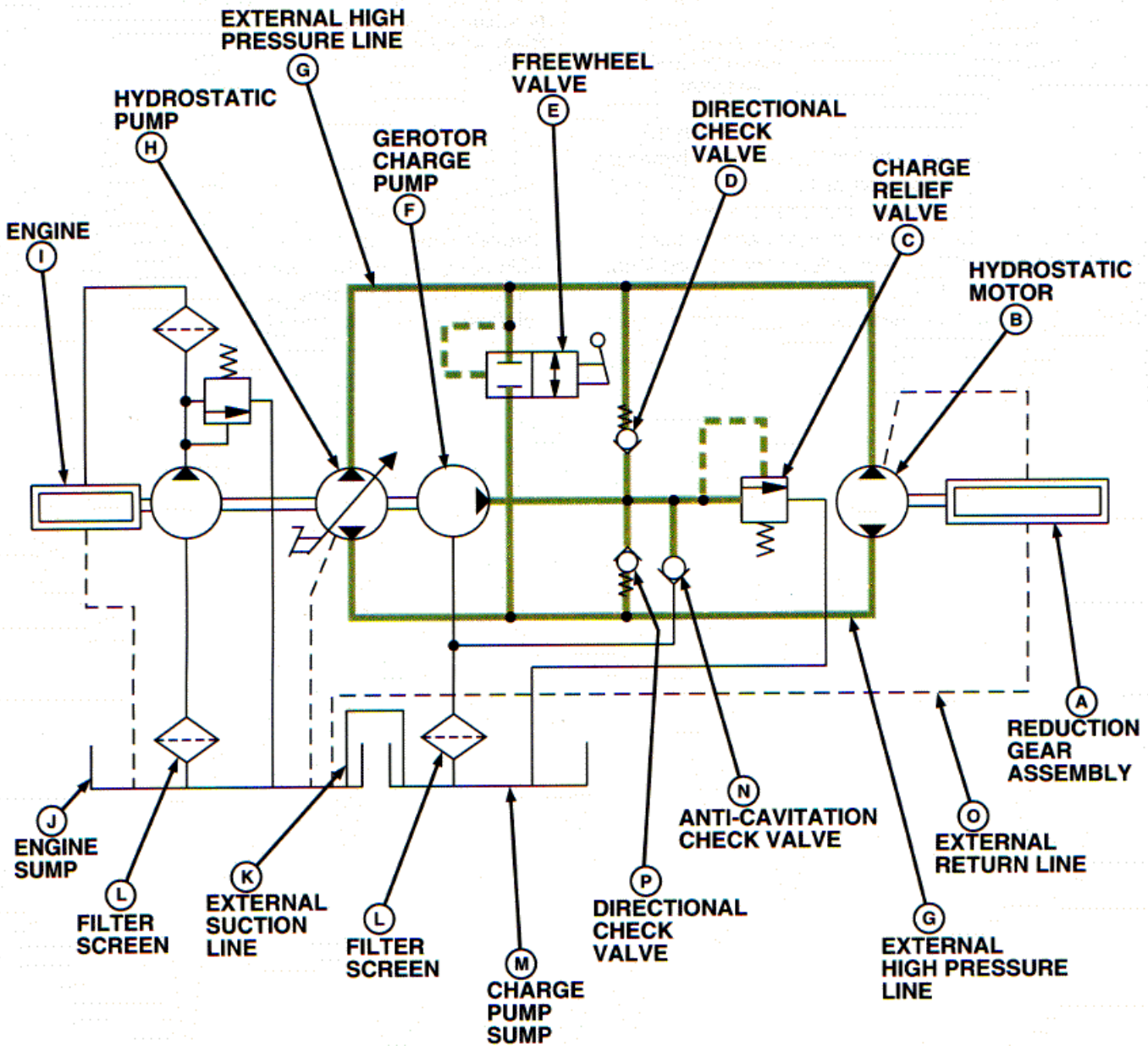

Q TRAPPED OIL

MC83016

FREEWHEEL VALVE OPERATION - PRE-ENGAGEMENT

250
10
15
-19-
MC83016

MX,25010CL,17 -19-23OCT95

FREEWHEEL VALVE OPERATION—ENGAGEMENT

A—Reduction Gear Assembly	G—External High Pressure Lines	K2—Internal Suction Passage (110001—)	O—External Return Line
B—Hydrostatic Motor	H—Hydrostatic Pump	L—Filter Screens	P—Low Pressure Oil
C—Charge Relief Valve	I—Engine	M—Charge Pump Sump	Q—Trapped Oil
D—Directional Check Valves	J—Engine Sump	N—Anti-Cavitation Check Valve	R—Return/Pressure-Free Oil
E—Free-Wheel Valve	K1—External Suction Line (—110000)		
F—Gerotor Charge pump			

In order to push the unit, the freewheel valve (E) must be engaged fully. The freewheel valve bypasses the hydrostatic pump portion of the closed loop and creates a passage between the closed loops. Low pressure oil (P) from the motor flows across the freewheel valve to the other side of the closed loop. The oil now enters the inlet side of the motor as make-up oil. The hydrostatic pump (H) is bypassed

allowing the unit to be pushed. The freewheel valve stays in the bypass position until the engine is started and charge pressure oil, through the pilot passage of the freewheel valve, pushes the valve closed, provided the actuating lever is FULLY disengaged. If this is not done, the lever may prevent the valve from disengaging completely, which will drastically reduce oil flow and ground speed in either direction.

250
10
16

MX,25010CL,18 -19-23OCT95

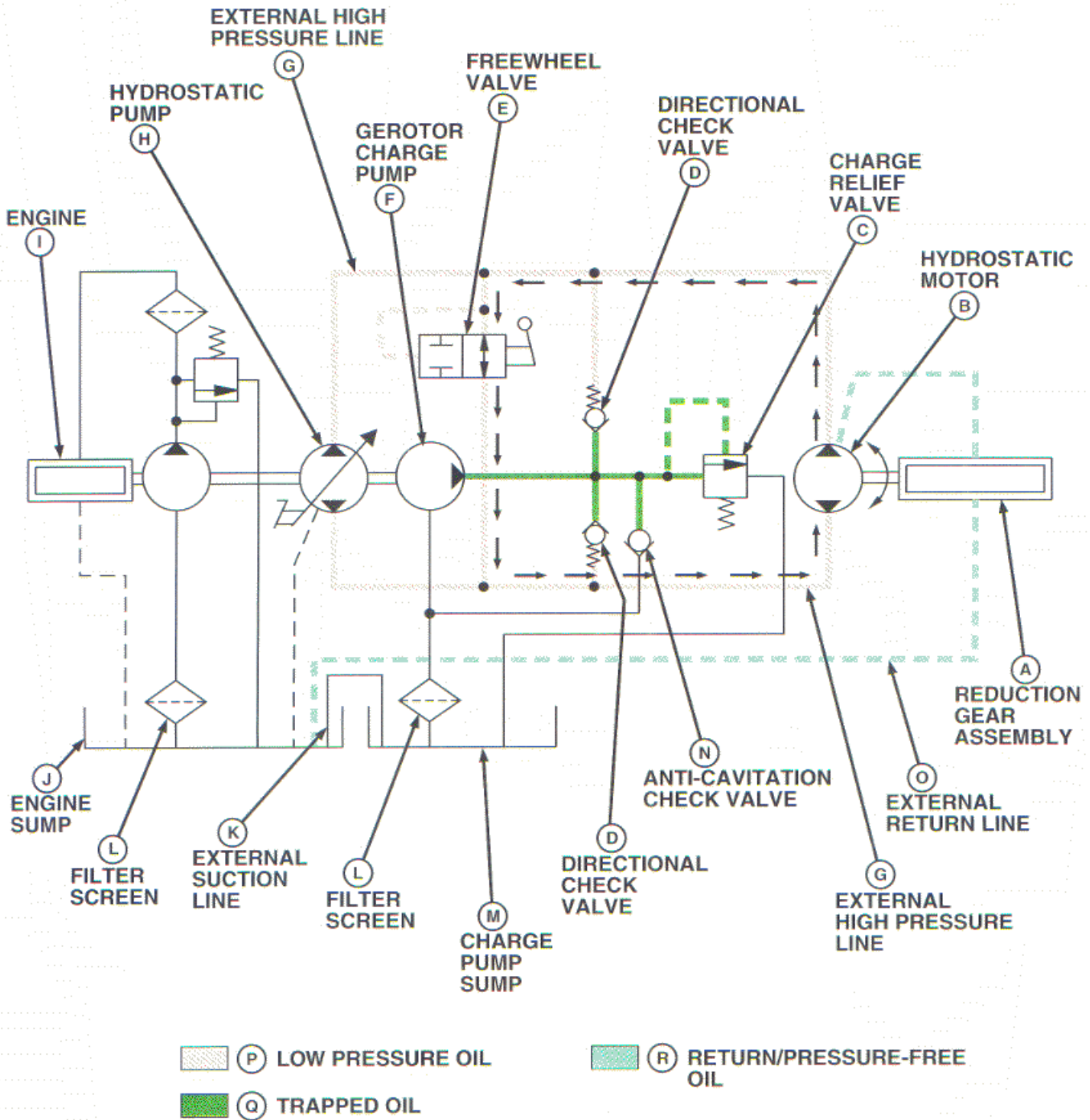

250
10
17

MC83017

FREEWHEEL VALVE OPERATION - ENGAGEMENT

MC83017 -1B-

POWER FLOW FROM THE MOTOR

The motor rotating group (A) is splined to, and drives a hollow shaft (B). The end of shaft (B) is eccentric. Since the eccentric is part of the shaft for every revolution of the shaft, the eccentric revolves once also. Pressed onto the eccentric is a ball bearing (C). The eccentric/ball bearing combination drives the gear reduction set (not shown).

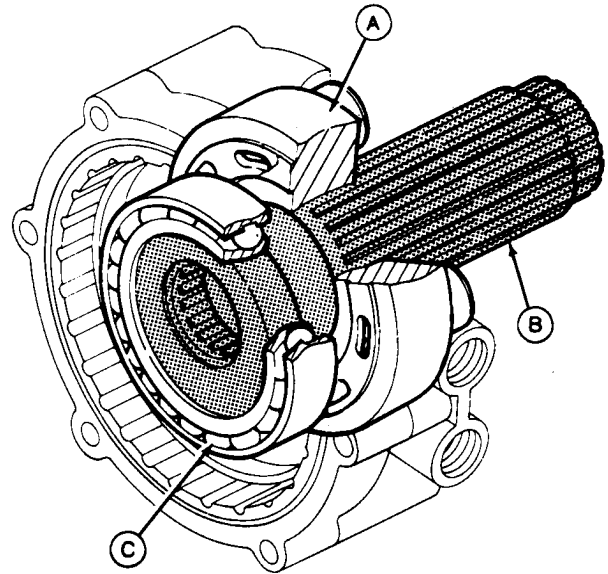

250
10
18

M53379 -JUN-21AUG89

MX,25010CL,A12 -19-23OCT95

Riding on top of bearing (A) is a gear (B). The outer perimeter of the gear is cycloidal design (round teeth). The gear has 25 external teeth. The gear revolves within 26 roller bearings (C) that are indexed in the housing.

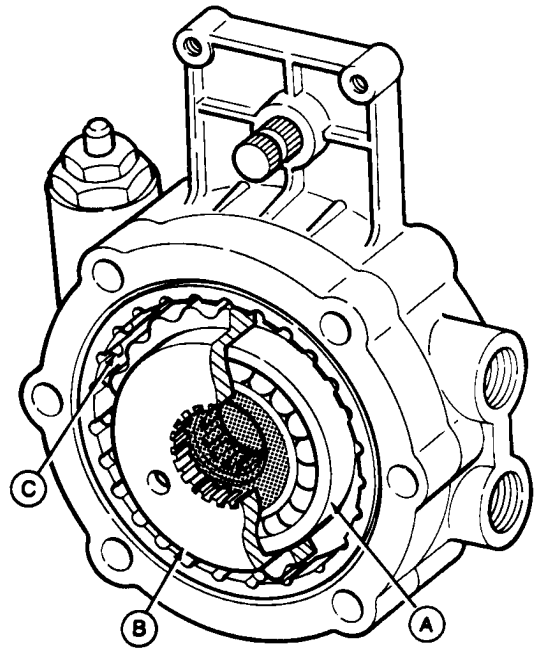

MX,25010CL,A13 -19-23OCT95

M52461 -JUN-21AUG89

250
10
19

GEAR REDUCTION ASSEMBLY OPERATION

As the motor output shaft rotates, cycloidal gear (A) rotates on its axis around eccentric and bearing (B). This causes gear (A) to revolve within the gear housing and roller bearings (C). After one complete turn of the motor shaft, the cycloidal gear has moved over one tooth from its original position. Follow this sequence thru from position 1 through position 4 which illustrates one rotation of the motor shaft. When the motor shaft has rotated 25 times the gear will have made one complete revolution.

250
10
20

MX,25010CL,A14 -19-04MAY92

GEAR REDUCTION ASSEMBLY OPERATION

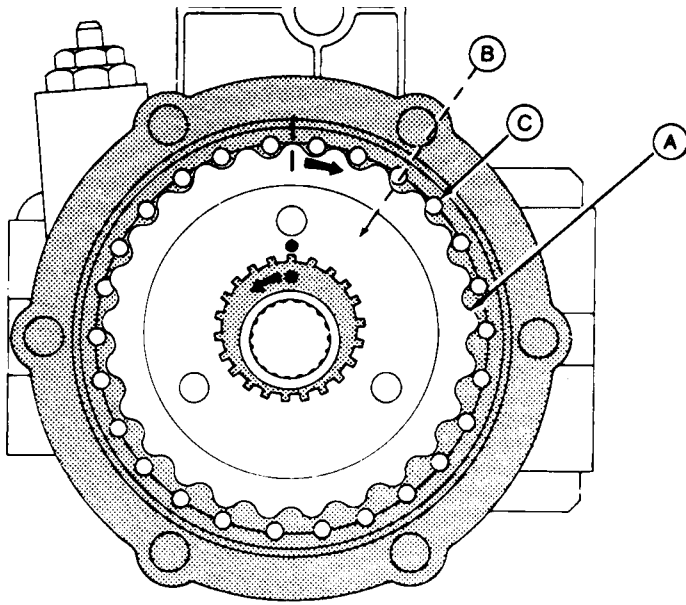

1

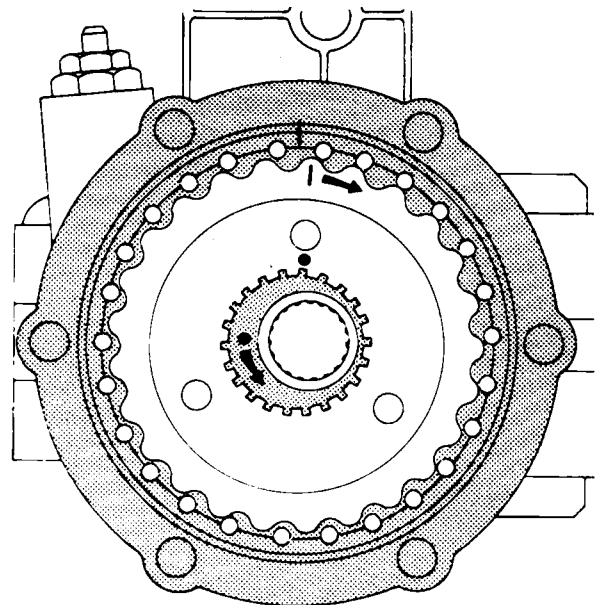

2

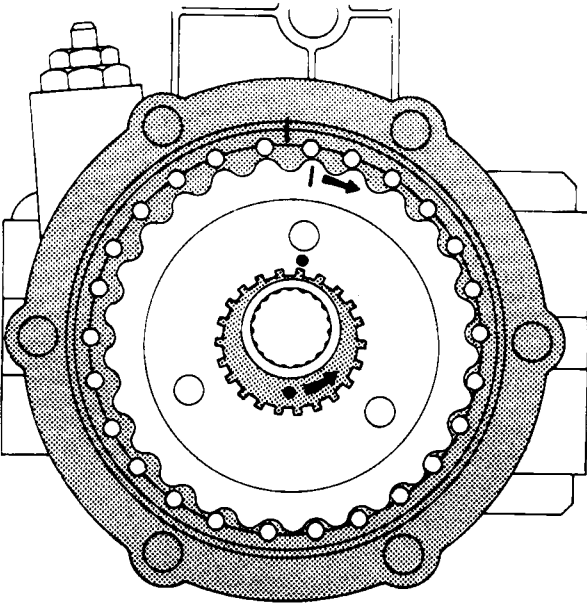

3

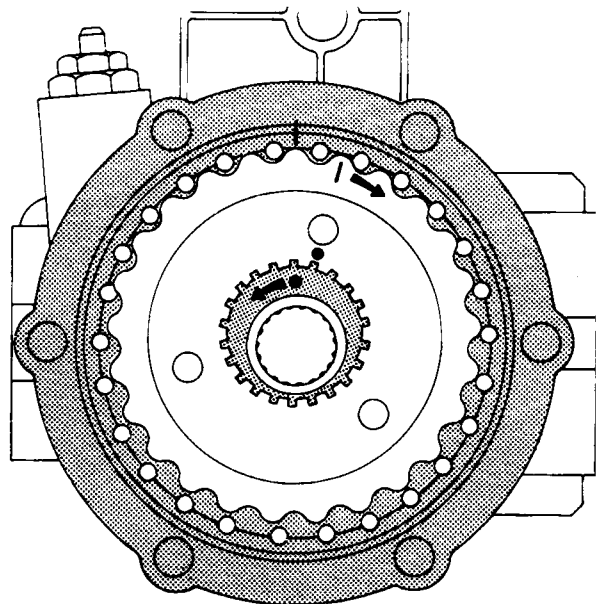

4

A—Cycloidal Gear

B—Bearing

C—Roller Bearings

250
10
21

M52462 -UN-21AUG89

MX,25010CL,A14A-19-23OCT95

DIFFERENTIAL OPERATION

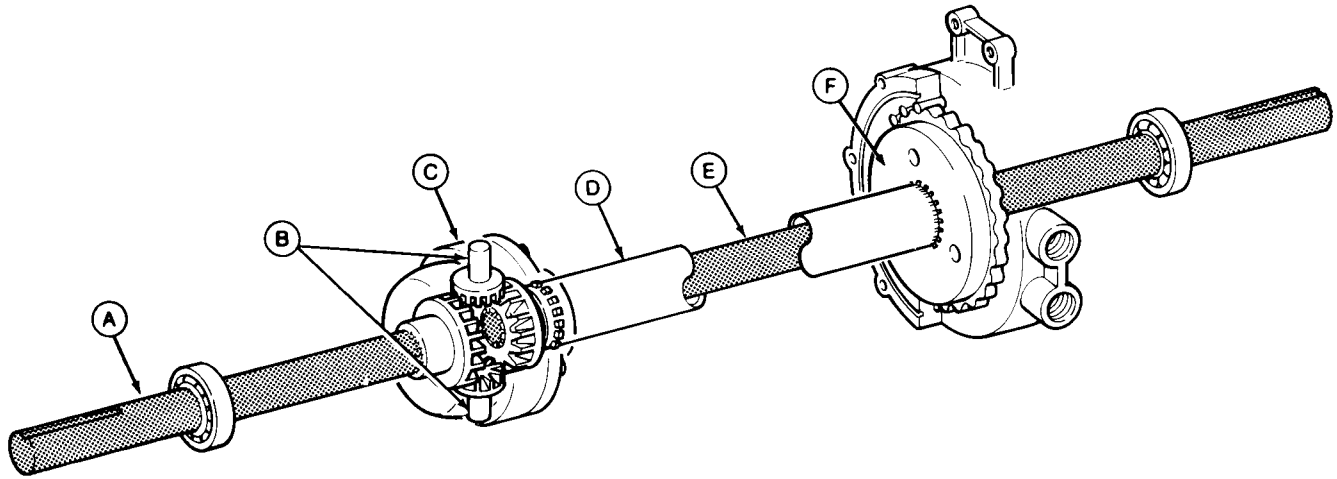

A—Wheel Axle
B—Pinion Gears

C—Differential Assembly
D—Differential Drive Shaft

E—Wheel (Final Drive) Axle F—Reduction Gear Set

Shaft (D) couples the reduction gear set (F) to the differential assembly (C). The shaft is splined at both ends. One end splined to the cycloidal gear, and the other splined to the differential carrier. The shaft is also hollow, to allow the final drive axle (E) to pass through.

The differential is a two pinion bevel gear style. Power to the differential assembly is transmitted

through the pinion gears (B) to the bevel gears which are splined to the wheel axles (A and E).

The final drive axle (E), is somewhat unique in that it runs through the hollow differential drive shaft (D), reduction gear set, motor output shaft, and hydrostatic motor rotating group.

MX,25010CL,A15 -19-23OCT95

250
10
22

-JUN-24-JUL-95
M52463

BEFORE YOU START

The procedures in this group provide you with the information to isolate a malfunction. It is assumed that you are familiar with the machine and its transmission components.

Always start with the first test and follow the sequence. Use the diagram to identify the test points.

MX,25015CL,A5A -19-04MAY92

250
15
1

LACK OF DRIVE OR LIMITED SPEED IN BOTH DIRECTIONS

TEST/CHECK POINT	NORMAL	IF NOT NORMAL
1. Swash plate movement	Full arm movement and splines in good shape	Check linkage, swash plate arm and connection. Replace stripped splined components.
2. Brake arm	Snaps back when released	Check brake and brake linkage.
3. Engine dipstick	Normal oil level	Fill/delete oil.
4. Freewheel valve	Pops up fully when engine is running and actuating lever disengaged fully	Remove, inspect, and repair freewheel valve and actuating lever.
5. Suction line	No air leaks	Replace line.
6. Sump screen	Clean	Remove debris.
7. Pump drive shaft	Gear and shaft intact	Replace drive shaft and possibly camshaft.
8. Charge pump -tip and side clearance	Components intact and within specification	Replace pump components.
9. Anti-Cavitation valve	Valve and seat intact and valve free	Replace valve and seat.
10. Charge relief valve and relief valve spring	Valve and seat intact and to specification	Replace valve and/or housing. Replace spring.
11. Directional control valves and springs	Valve/seat intact, free and to specification	Replace valves, and/or housing. Replace springs.
12. Hydrostatic pump rotating group	No damage or wear	Replace rotating group.
13. Hydrostatic pump tension spring	Intact and to specification	Replace spring.
14. Pump to motor lines	No damage or leaks	Replace lines.
15. Hydrostatic motor rotating group	No damage or wear	Replace rotating group.
16. Hydrostatic motor tension spring	Intact and to specification	Replace spring.
17. Final drive components -Motor output shaft -Gear reduction set -Differential drive shaft -Differential	Intact, functional and within specification	Replace components.

250
15
2

LACK OF DRIVE OR LIMITED SPEED IN BOTH DIRECTIONS

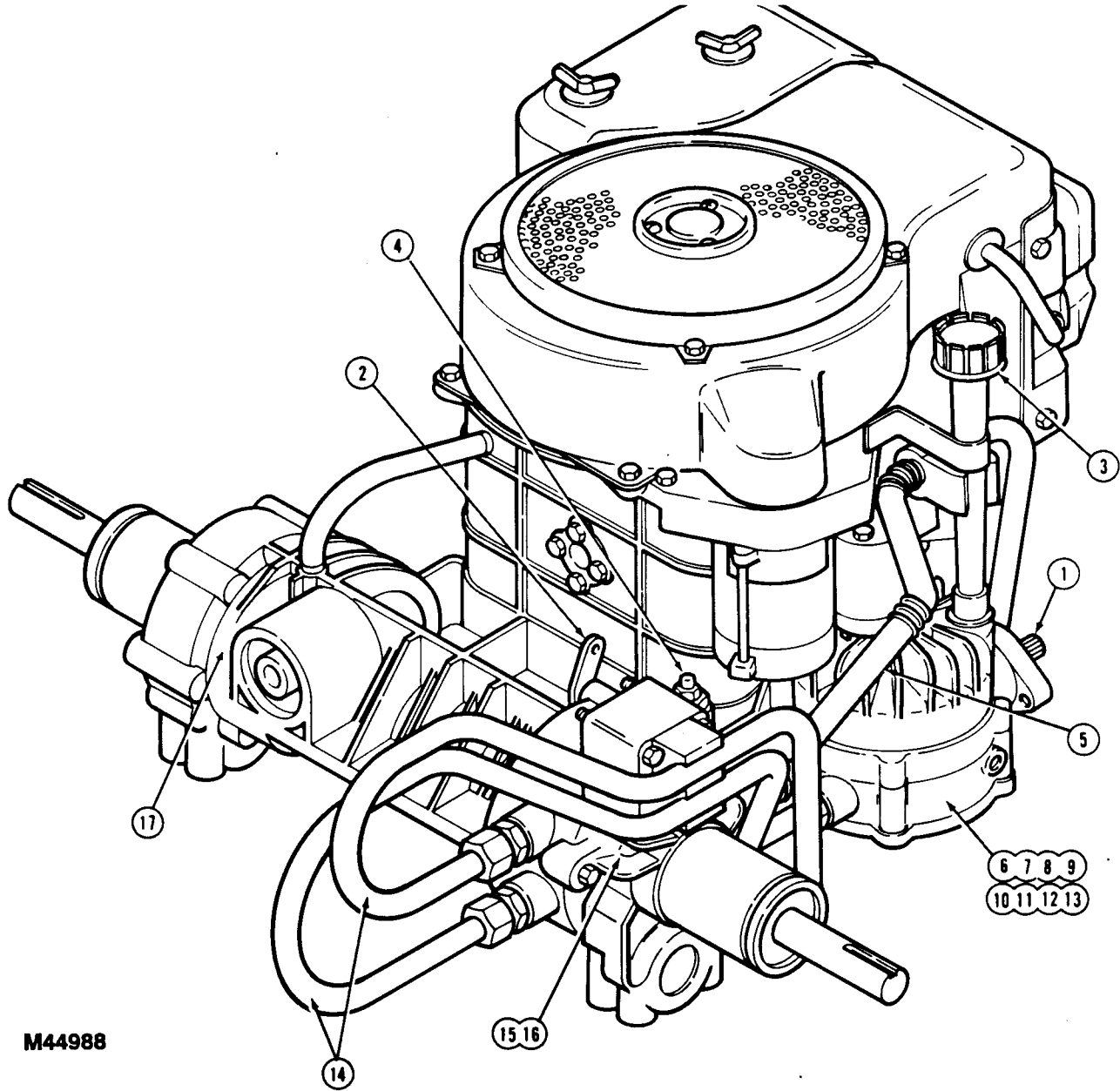

M44988

MX,25015CL,A6 -19-23OCT95

250
15
3

M44988
-19-22APR92

LACK OF DRIVE OR LIMITED SPEED IN ONE DIRECTION

TEST/CHECK POINT	NORMAL	IF NOT NORMAL
1. Swash plate movement	Full arm movement and splines in good shape	Check swash plate arm and linkage connection, loose or bent pedal, directional pedal travel adjustment, control lever shaft adjustment and replace stripped spline components.
2. Brake arm	Snaps back from engaged position	Check brake and brake linkage.
3. Directional control valves	Ball and seat intact, ball free	Replace valve, refurbish seat.
4. Directional control valve springs	Free length to specification	Replace springs.
5. Pump to motor lines and fittings	No damage, leaks, or restrictions	Replace lines or fittings.
6. Freewheel valve and lever	Valve pops up fully and lever disengages fully	Replace valve and actuating lever.

250
15
4

MX,25015CL,A7 -19-23OCT95

TEST/CHECK POINTS 1-5 (LACK OF DRIVE OR LIMITED SPEED IN ONE DIRECTION)

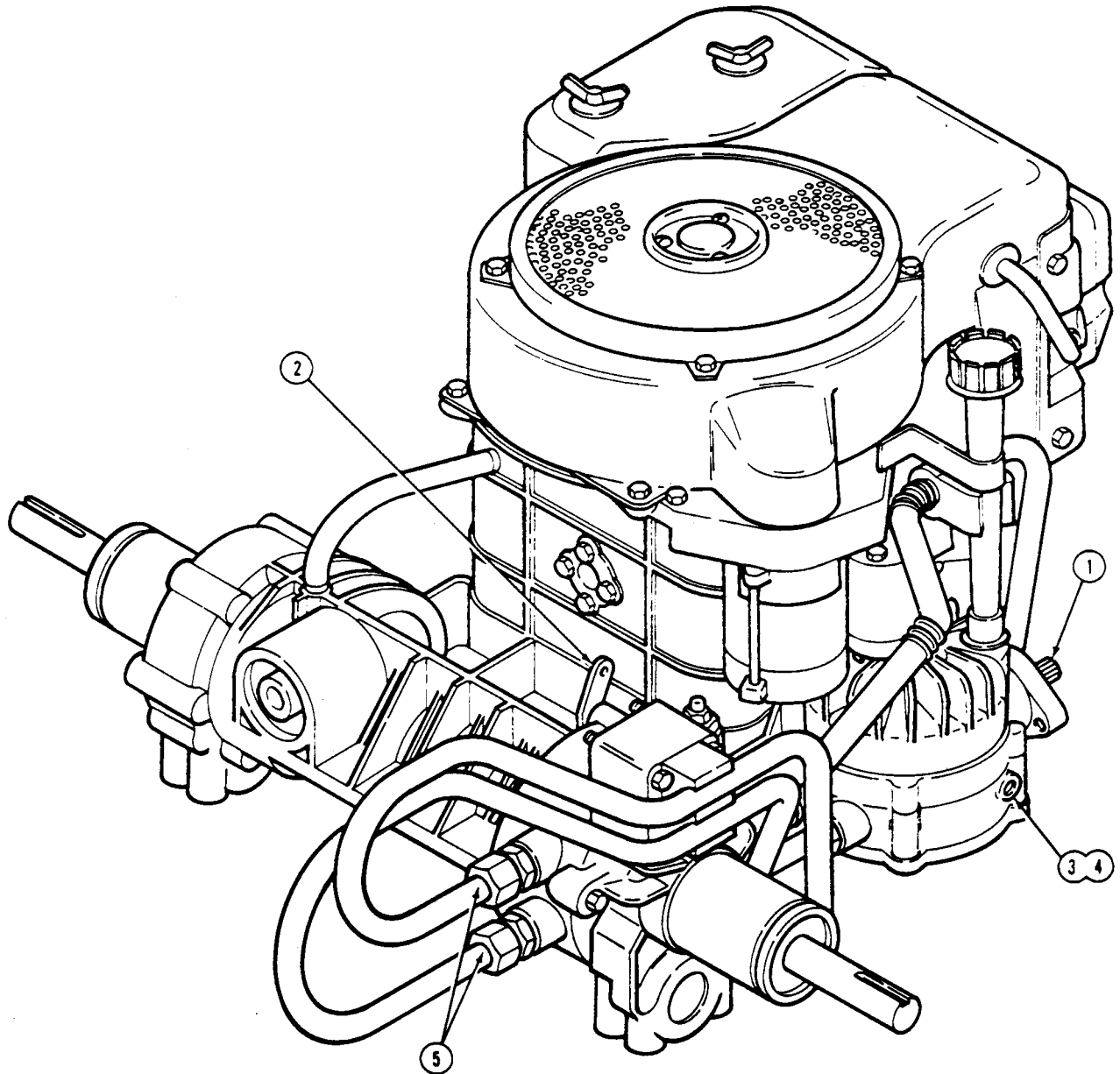

250
15
5

M53375 -JUN-21AUG89

MX,25015CL,A8 -19-04MAY92

ERRATIC DRIVE IN BOTH DIRECTIONS

TEST/CHECK POINT	NORMAL	IF NOT NORMAL
1. Throttle control plate (engine rpm)	Within specification	Adjust governor linkage.
2. Swash plate movement	Full arm movement and splines in good shape	Adjust linkage, check attachment point and replace stripped spline components.
3. Brake arm	Snaps back when released	Check brake and brake linkage.
4. Engine dipstick	Normal oil level, correct oil	Add/delete, or change oil.
5. Freewheel valve	Pops up fully when engine is running and actuating lever is disengaged fully	Remove, inspect, and repair freewheel valve and actuating lever.
6. Charge relief valve and spring	Within specification no damage	Replace charge pressure spring and or relief valve.
7. Sump screen	Clean	Remove debris.
8. Charge pump -Tip clearance -Side clearance	Components intact and within specifications	Replace pump components.
9. Anti-Cavitation valve	Valve and seat intact, valve free	Replace valve and seat.
10. Directional control -valves -springs	Valve and seat intact, free and to specification	Replace valves, and/or housing. Replace springs.
11. Hydrostatic pump -Rotating group -Tension spring -Swash plate bearing	No damage or wear, intact and to specification	Replace rotating group. Replace spring. Replace swash plate.
12. Pump to motor lines	No restriction, or damage	Replace lines.
13. Hydrostatic motor -Rotating group -Tension Spring -Thrust bearing	No damage or wear, intact and to specification	Replace rotating group. Replace spring. Replace bearing.
14. Final drive components -Motor output shaft -Gear reduction set -Differential drive shaft -Differential -Wheel axles	Intact, functional, and within specification	Replace components.

250
15
6

TEST/CHECK POINTS 1 – 14 (SLOW/ERRATIC DRIVE IN BOTH DIRECTIONS)

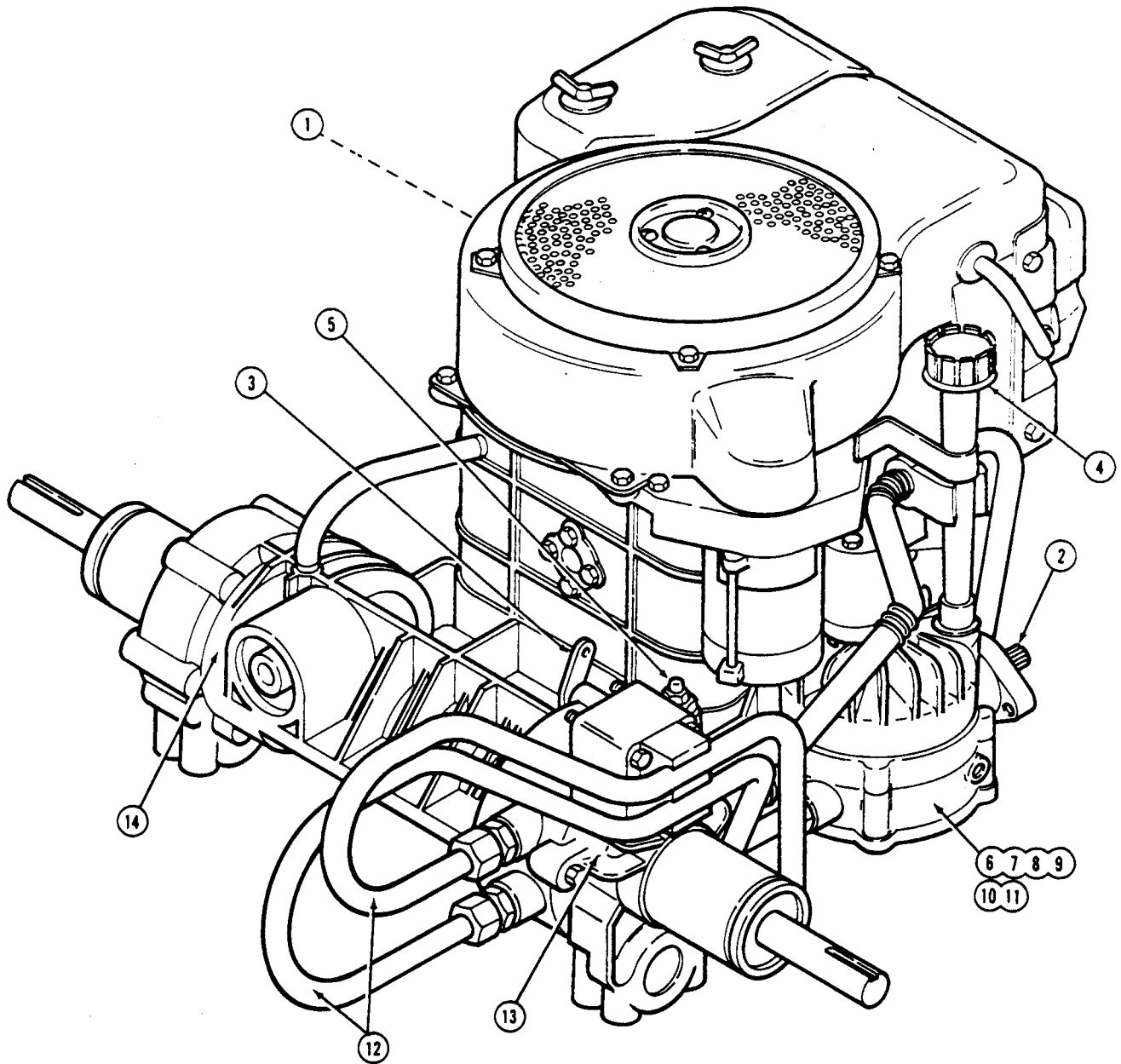

250
15
7

M53376 -JUN-21/AUG89

MX,25015CL,A10 -19-04MAY92

MACHINE CREEPS WHEN IN NEUTRAL

TEST/CHECK POINT	NORMAL	IF NOT NORMAL
1. Swash plate control shaft to arm connection	Tight, no tolerance and splines in good shape	Tighten or repair components.
2. Control arm return spring	Intact, good tension	Replace spring.
3. Cam roller	Bearing free, no damage	Replace roller.
4. Cable	No damage, binding, adjusted to specification	Replace and/or adjust cable.
5. Shock absorber	No damage or binding	Replace shock absorber.
6. Pedals and pedal linkage	No binding or damage	Repair as necessary.
7. Cam roller eccentric	Adjusted for neutral	Adjust as necessary.
8. Swash plate pivot point	No wear, binding, or excess tolerance	Replace faulty components.

MX,25015CL,A11 -19-23OCT95

250
15
8

TEST/CHECK POINTS 1 – 8 (MACHINE CREEPS WHEN IN NEUTRAL)

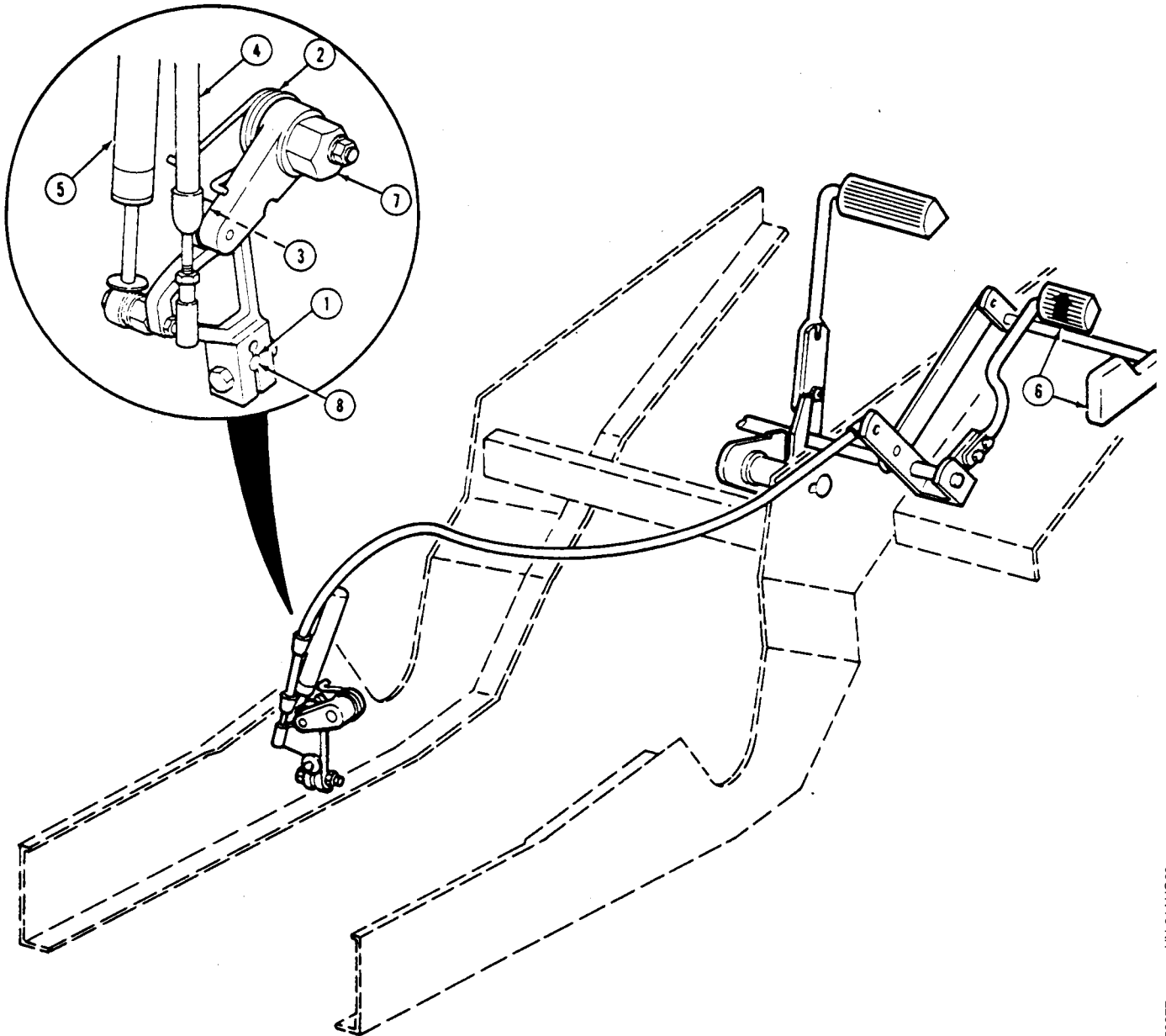

250
15
9

M53377
-UN-21AUG89

MX,25015CL,A12 -19-04MAY92

TRANSMISSION DOES NOT NEUTRALIZE WHEN THE BRAKES ARE APPLIED

TEST/CHECK POINT	NORMAL	IF NOT NORMAL
1. Swash plate control shaft to arm connection	Tight, no tolerance and splines in good shape	Tighten or repair components.
2. Control arm return spring	Intact, good tension	Replace spring.
3. Cam roller	Bearing free, no damage	Replace roller.
4. Cable	No damage, binding, adjusted to specification	Replace and/or adjust cable.
5. Shock absorber	No damage or binding	Replace shock absorber.
6. Cam roller eccentric	Adjusted for neutral	Adjust as necessary.
7. Pedals and pedal linkage	No binding or damage	Repair as necessary.
8. Swash plate pivot point	No wear, binding, or excess tolerance	Replace faulty components.
9. Return to neutral adjusting slot	Adjusted for neutral	Adjust as necessary.

250
15
10

MX,25015CL,A13 -19-23OCT95

TEST/CHECK POINTS 1 – 9 (TRANSMISSION DOES NOT NEUTRALIZE WHEN BRAKE IS APPLIED)

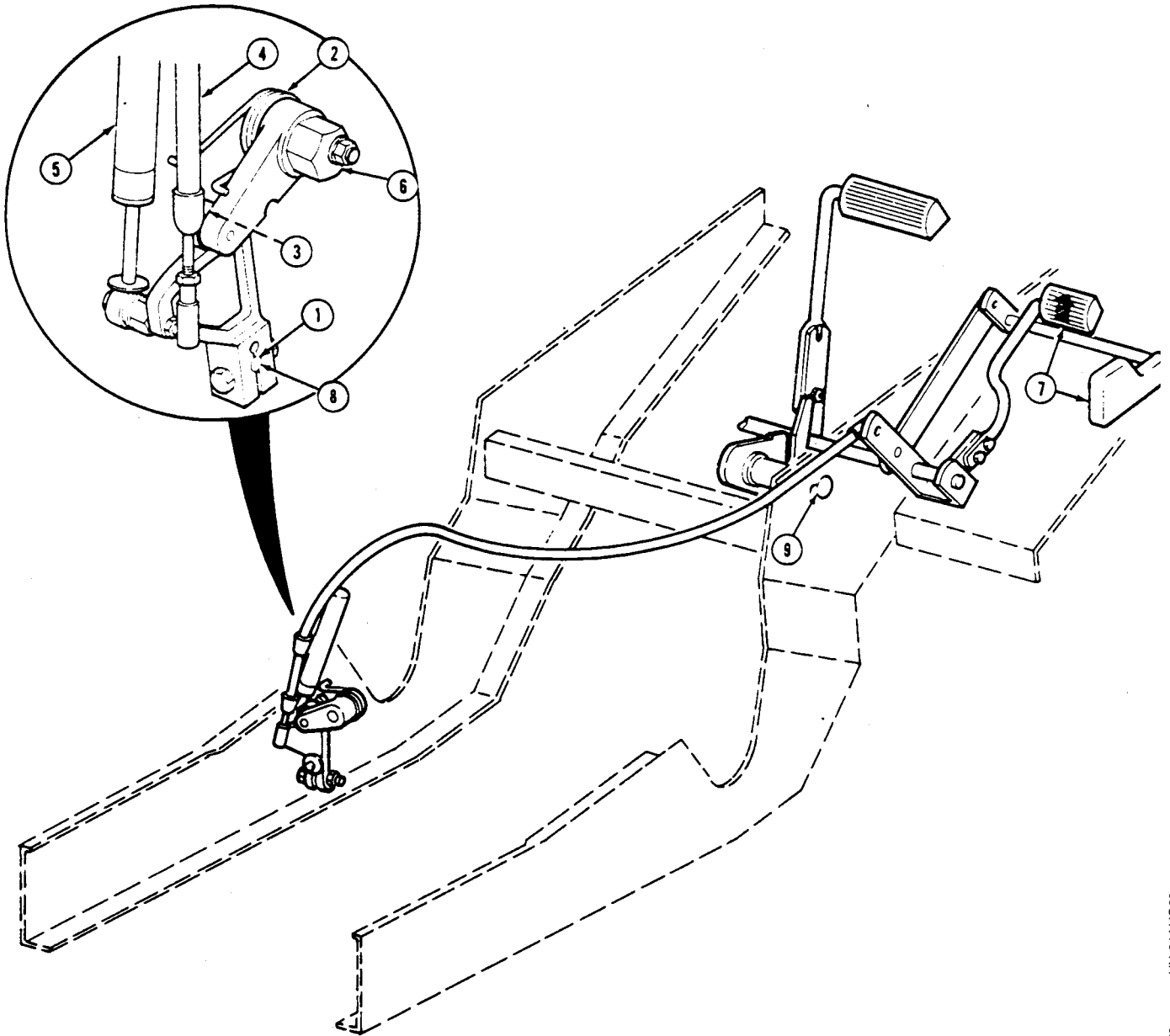

250
15
11

M53378 -UN-21AUG89

MX,25015CL,A14 -19-04MAY92

DIRECTIONAL PEDAL TRAVEL ADJUSTMENT

Reason:

To ensure full travels speed in forward and reverse directions. This also ensures that the transmission swashplate does not act as a mechanical stop for the pedal linkage.

Procedure:

1. Put transmission in **neutral**. Disengage PTO. Engage park brake.
2. Turn key switch to **OFF** position.
3. Raise and lock seat platform.
4. Raise rear shroud.
5. Pedal travel is adjusted at (A), (B) and (C).
6. Adjustment point (A) adjusts pedal travel.
7. Adjustment points (B) and (C) adjust swash plate lever travel.
8. Adjust cable so full forward and reverse swash plate travel is achieved **prior to bottoming out the pedal**.

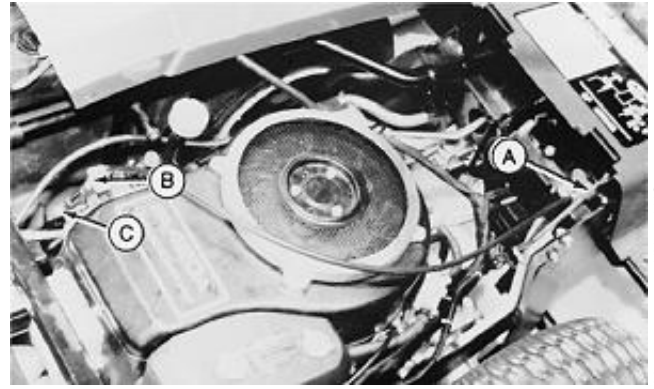

M53307 -UN-25AUG89

250
15
12

MX,25015CL,A2 -19-23OCT95

DIRECTIONAL PEDAL—NEUTRAL ADJUSTMENT

Reason:

If the machine creeps forward or backward with the direction pedals in the neutral position and parking brake released and engine running, the eccentric must be adjusted.

NOTE: Pedal linkage/control shaft is located on the left side of the engine near the battery.

Procedure:

1. Put transmission in **neutral**. Disengage PTO. Engage park brake.
2. Turn key switch to **OFF** position.
3. Raise and lock seat platform.
4. Raise rear shroud.
5. Disconnect cable (G) and shock absorber (A).
6. Check that roller (C) is in notch (D).
7. Check that dot (F) on swash plate control shaft is aligned with line (E) on right side of swash plate control lever. If necessary, loosen nut and move swash plate control lever for correct alignment.
8. Raise drive wheels off ground and support front mower securely.
9. Start and run engine at wide open throttle.
10. Adjust eccentric (E) until neutral is achieved. (wheels stop turning.)
11. Install cable and shock absorber.

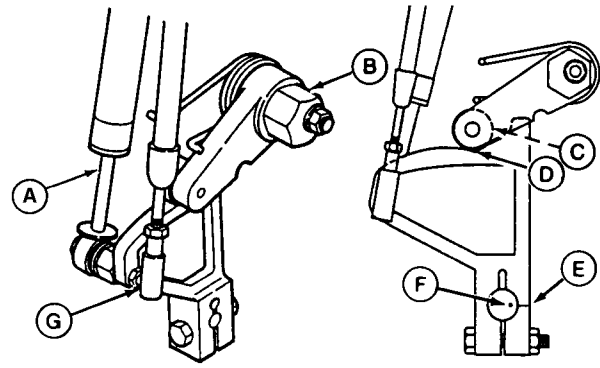

- A—Shock Absorber
- B—Eccentric
- C—Cam Follower Roller
- D—Neutral Notch
- E—Line
- F—Dot
- G—Control Cable

M53159 -UN-24-JUL95

250
15
13

MX,25015CL,A3 -19-23OCT95

NEUTRAL RETURN LINKAGE ADJUSTMENT

Reason:

To make sure that the transmission returns to neutral when the park brake is engaged.

NOTE: The linkage is located under the foot platform.

Procedure:

1. Put transmission in **neutral**. Disengage PTO.
2. Turn key switch to **OFF** position.
4. Depress brake pedal.
5. Roller (A) should be in slot (B). If not, follow steps 6—7.
6. Lock park brake.
7. Adjust eccentric (C) until neutral cam (D) raises and catches roller in slot.

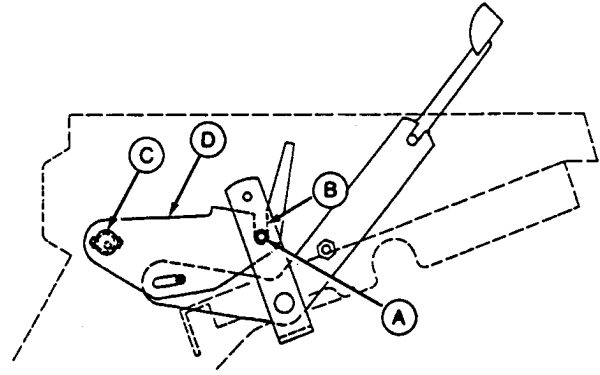

A—Roller
B—Neutral Slot
C—Eccentric
D—Neutral Cam

M53158 -UN-21AUG89

250
15
14

MX,25015CL,A4 -19-23OCT95

CONTROL VALVE ADJUSTMENT

Reason:

To make sure that transmission is providing maximum forward ground speed.

NOTE: The control valve is located on the left side of the engine near the battery.

Procedure:

1. Raise machine so one wheel is off ground and support machine securely.
2. Raise and lock seat platform.
3. Raise rear shroud.

NOTE: Throttle cable/shock absorber bracket and control lever removed from swash plate control housing for clarity.

4. Loosen cap screws (B) securing swash plate control housing.
5. Start engine. Fully depress forward directional pedal.
6. Check speed of raised wheel using a photo tachometer (A).
7. Rotate housing (C) until wheel is turning at **216 rpm**.
8. Tighten housing cap screws to **24.5 N·m (217 lb-in.)**.

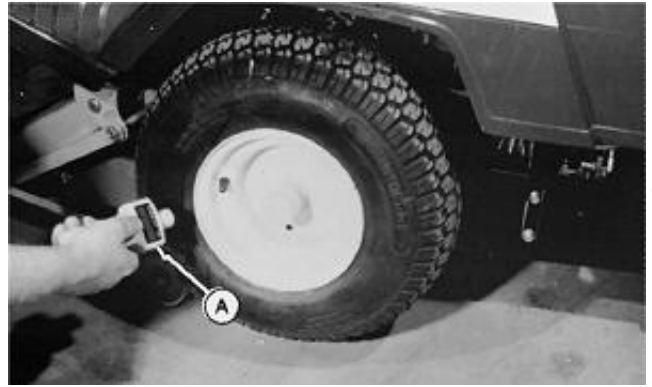

M53497 -UN-25AUG89

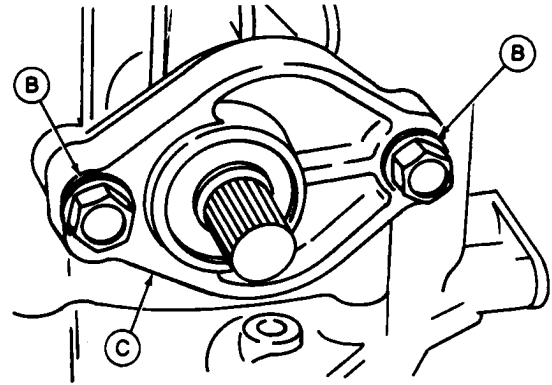

M52465 -UN-21AUG89

250
15
15

250
15
16

Section 260 STEERING OPERATION, TESTS, AND ADJUSTMENTS

Contents

Page

Group 05—Component Location

Steering System Components 260-05-1

Group 10—Theory of Operation

Steering Linkage Operation 260-10-1

Group 15—Diagnostics

Steering System Test Points 260-15-1

Group 20—Adjustments

Steering Linkage Adjustment 260-20-1

260

STEERING SYSTEM COMPONENTS

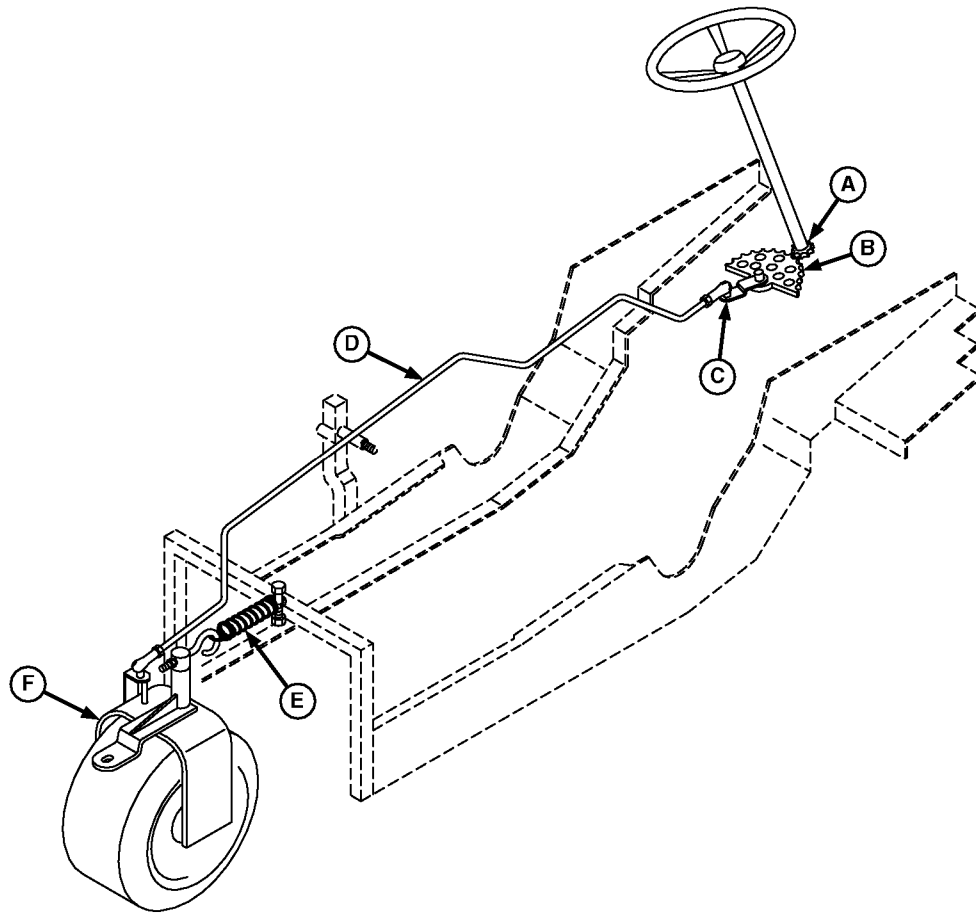

A—Pinion Gear/Shaft
Assembly

B—Sector Gear
C—Steering Arm

D—Drag Link
E—Return Spring

F—Steering Yoke Assembly

MX,26005CL,A1 -19-23OCT95

260
05
1

M53036 -JUN-04AUG95

260
05
2

STEERING LINKAGE OPERATION

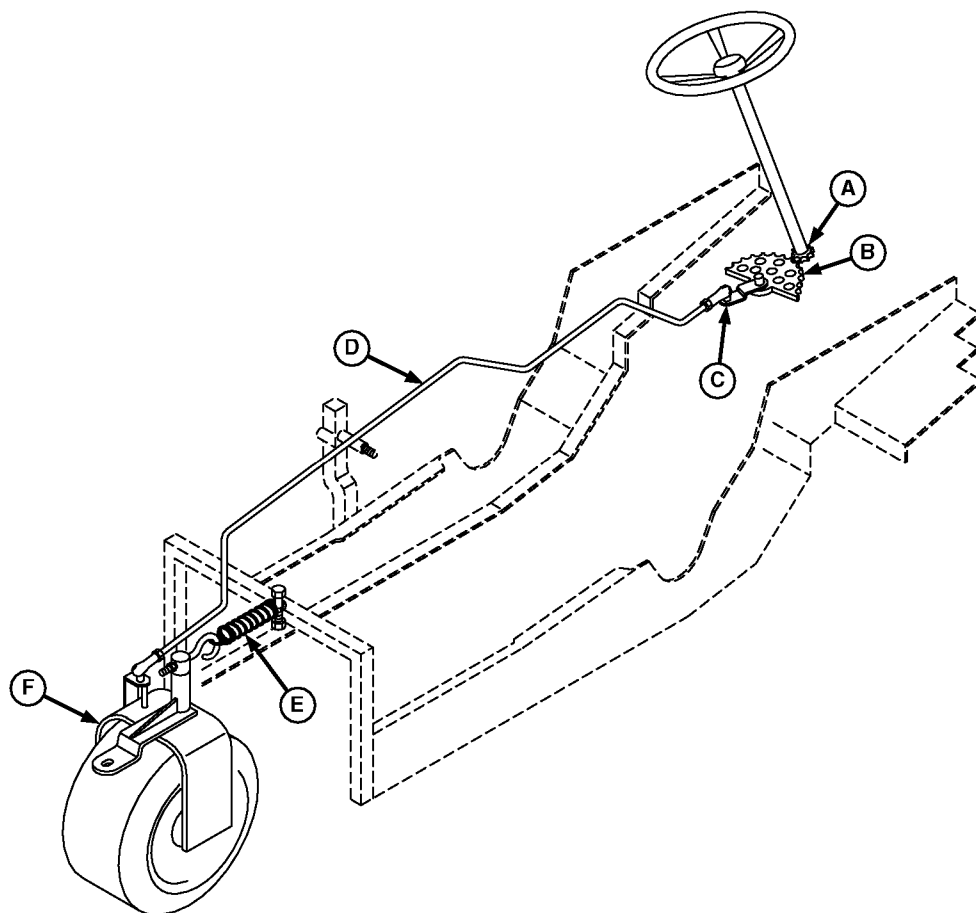

A—Pinion Gear/Shaft Assembly

B—Sector Gear
C—Steering Arm

D—Drag Link
E—Return Spring

F—Steering Yoke Assembly

Turning the steering wheel turns the pinion gear/shaft assembly (A). The pinion turns the sector gear (B) and arm (C) connected to a drag link (D). The drag

link connects to the rear steering yoke assembly (F). Return spring (E) assists the wheel to return to the straight ahead position.

MX,26010CL,A1 -19-23OCT95

260
10
1
M53036 -JUN-04/AUG95

260
10
2

STEERING SYSTEM TEST POINTS

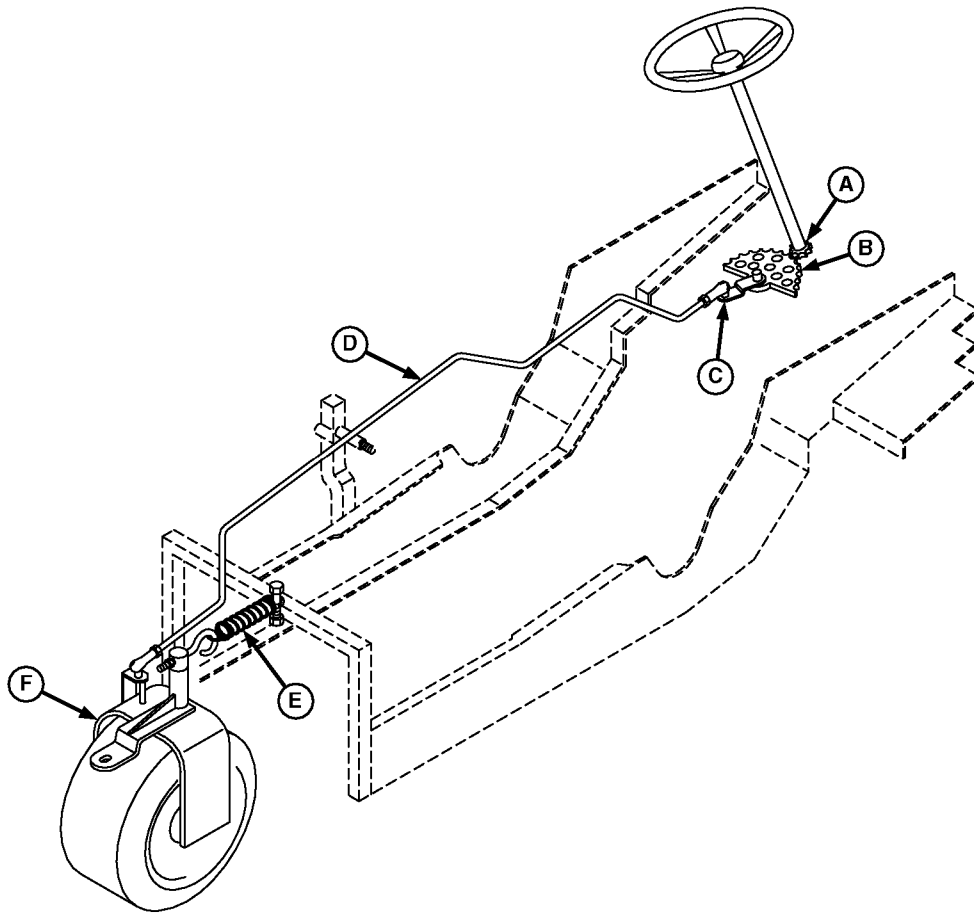

A—Pinion Gear/Shaft
Assembly

B—Sector Gear
C—Steering Arm

D—Drag Link
E—Return Spring

F—Steering Yoke Assembly

If binding or difficult steering occurs, check these points for wear or damage.

MX,26015CL,A1 -19-23OCT95

260
15

M53036 -JUN-04/AUG95

260
15
2

STEERING LINKAGE ADJUSTMENT

Reason:

To ensure that the steering wheel is in the centered (straight ahead) position when steering wheel is centered.

Procedure:

1. Put transmission in **neutral**.
2. Engage park brake.
3. Turn key switch to **OFF** position.
4. Raise and lock seat platform.
5. Raise rear shroud.
6. Turn steering wheel until steering yoke is in centered (straight ahead) position.
7. Remove ball joint (A) from bracket without moving steering yoke from centered position.
8. Loosen jam nut (B).
9. Turn steering wheel to straight ahead position (C).
10. Adjust linkage until ball joint (A) fits in bracket with steering yoke assembly centered.
11. Tighten jam nut (B) to **34 N·m (25 lb-ft)**.
12. Tighten ball joint (A) to bracket, without moving steering yoke assembly, to **37 N·m (27 lb-ft)**.

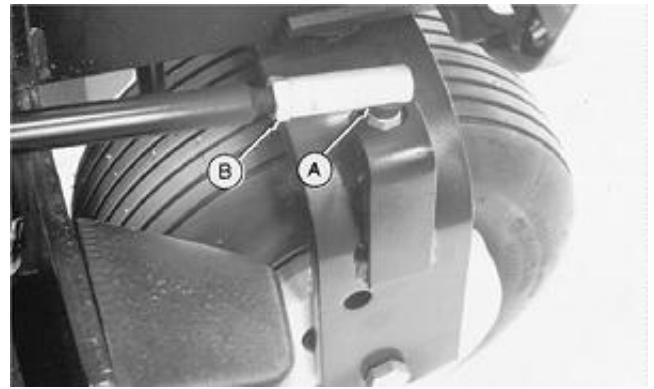

M53058 -UN-13APR89

M83015 -UN-27JUL95

260
20
1

MX,26015CL,A3 -19-23OCT95

Adjustments/Steering Linkage Adjustment

260
20
2

Section 265

BRAKE OPERATION, TESTS, AND ADJUSTMENTS

Contents

Page

Group 05—Component Location
Brake System Components 265-05-1

Group 10—Theory of Operation
Brake Linkage Operation 265-10-1

Group 15—Diagnostics
Brake System Test Points 265-15-1

Group 20—Adjustments
Brake Pedal Travel Adjustment 265-20-1

BRAKE SYSTEM COMPONENTS

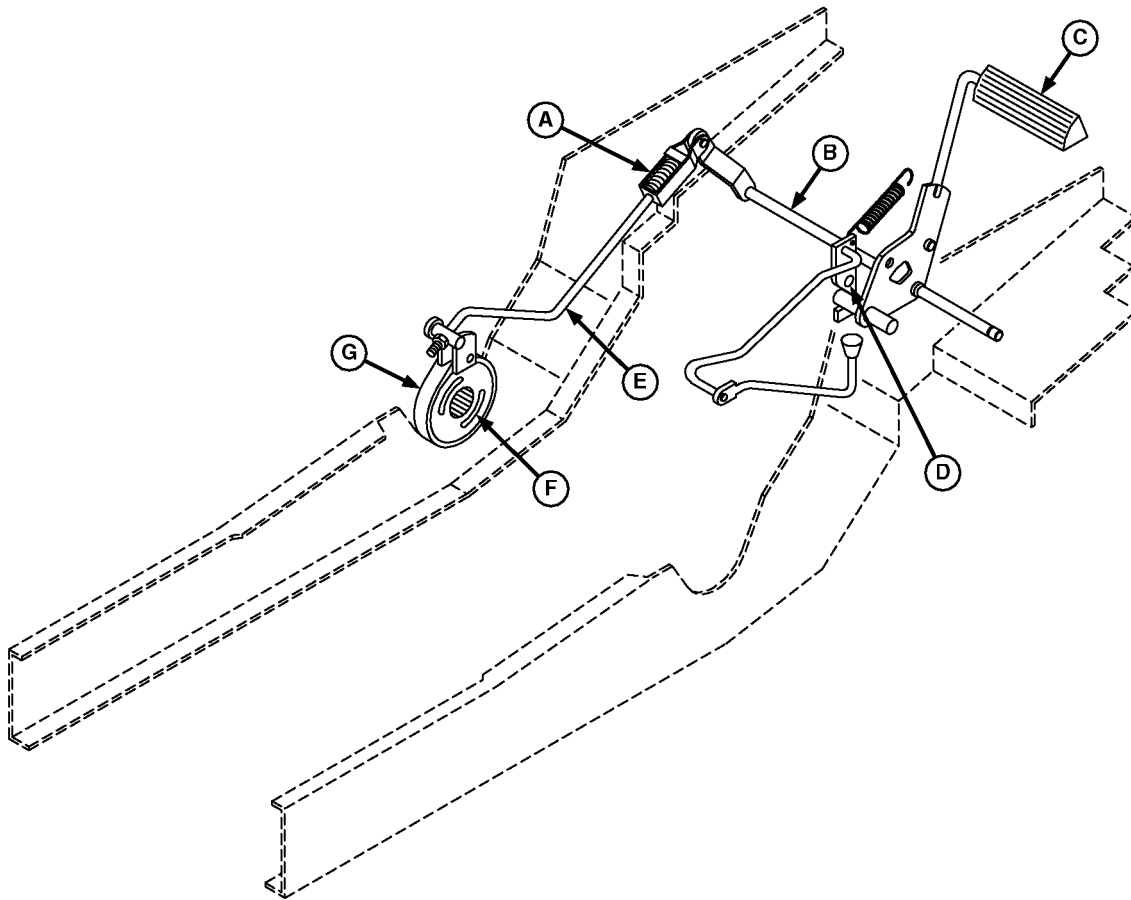

A—Compensating Spring Assembly

B—Brake Shaft Assembly
C—Pedal Assembly

D—Park Brake Assembly
E—Brake Rod

F—Hydrostatic Motor
G—Brake Band

M63031 -UN-04AUG95

MX,26005CL,A2 -19-23OCT95

265
05
1

265
05
2

BRAKE LINKAGE OPERATION

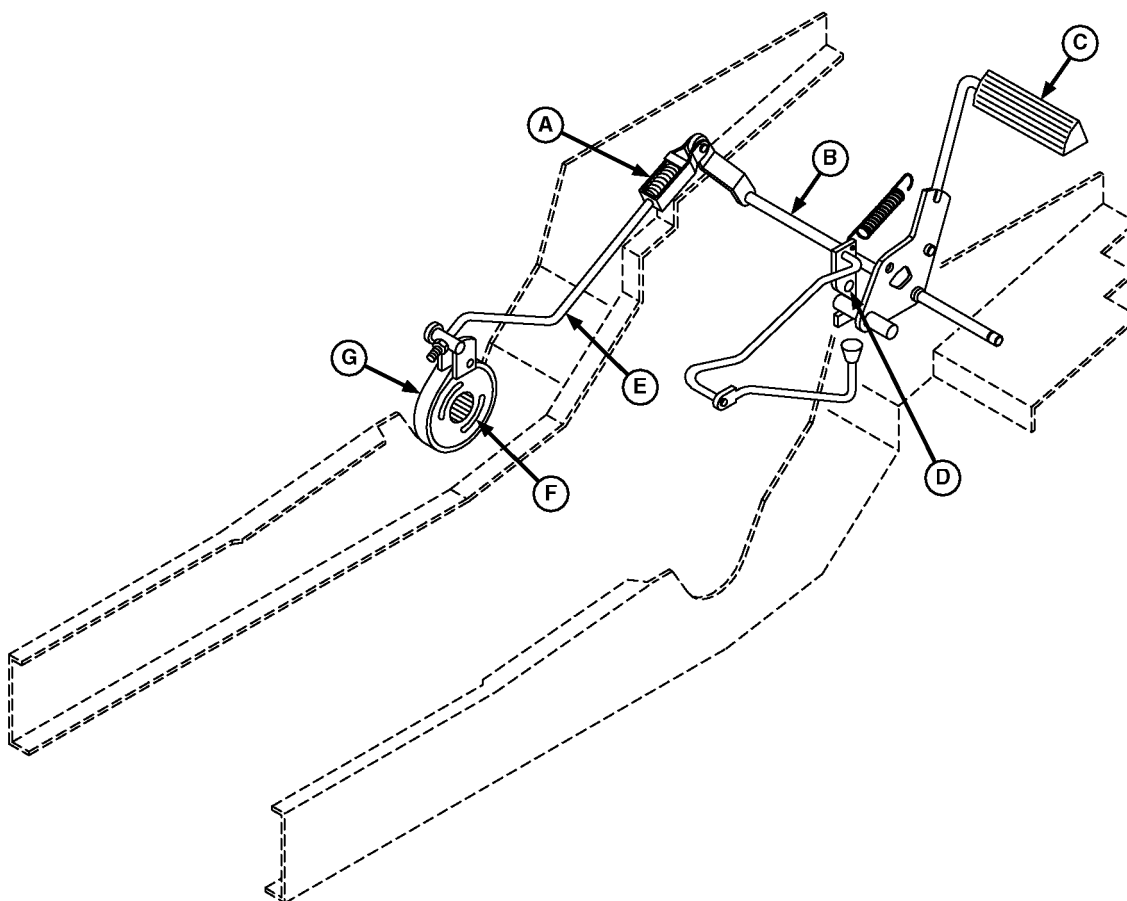

M63031 -JUN-04AUG95

A—Compensating Spring Assembly

**B—Brake Shaft Assembly
C—Pedal Assembly**

**D—Park Brake Assembly
E—Brake Rod**

**F—Hydrostatic Motor
G—Brake Band**

The brake system consists of a wet band design, inside the transmission housing. When the brake pedal (C) is depressed, the brake shaft (B) is rotated forward pulling on the brake rod (E). The brake rod is attached to the brake band assembly (G).

When the park brake is applied, a notch on the park brake assembly (D) engages a pin on the brake shaft assembly, holding the brake linkage in the **locked** position until the lever is released.

The brake band tightens around the hydrostatic motor (F). This prevents power from being transmitted to the drive wheels.

MX,26010CL,A2 -19-23OCT95

265
10
2

BRAKE SYSTEM TEST POINTS

If brake binding occurs, or brake will not hold, check these points for wear or adjustment.

- A—Brake Pedal Travel
- B—Compensating Spring
- C—Brake Band And Hydrostatic Motor

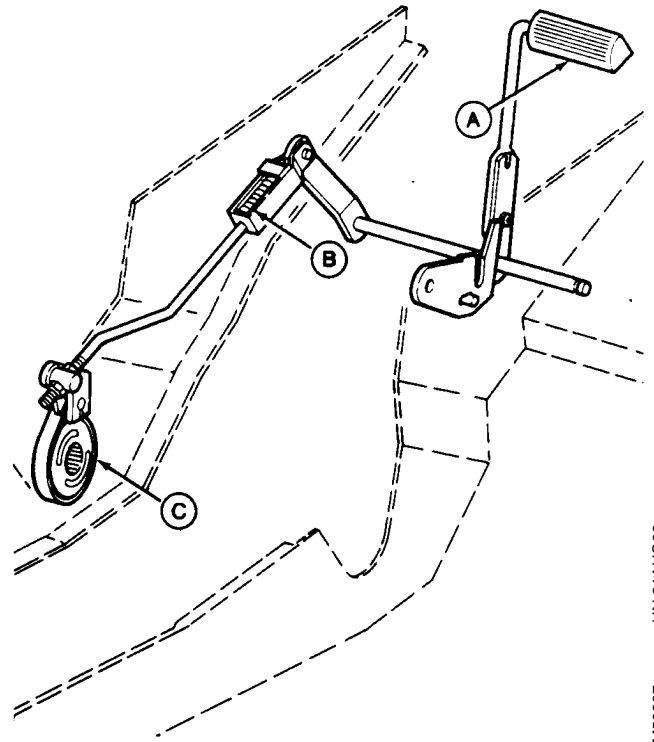

MX,26015CL,A2 -19-23OCT95

-JUN-21AUG89

M53287

265
15
1

265
15
2

BRAKE PEDAL TRAVEL ADJUSTMENT

Reason:

To ensure proper brake operation.

Procedure:

1. Lock park brake. Measure distance (A) from front of rod to front of slot. Unlock park brake.

*NOTE: Lift seat platform and observe compensating spring (D). Spring **SHOULD NOT** be compressed, just freeplay removed.*

2. Push pedal until resistance is felt.
3. Hold pedal and measure distance (A). The difference between measurements should be **15 mm (0.59 in.)**.
4. Loosen nut (B) and adjust linkage using nut (C).
5. Lock adjustment with nut (B).

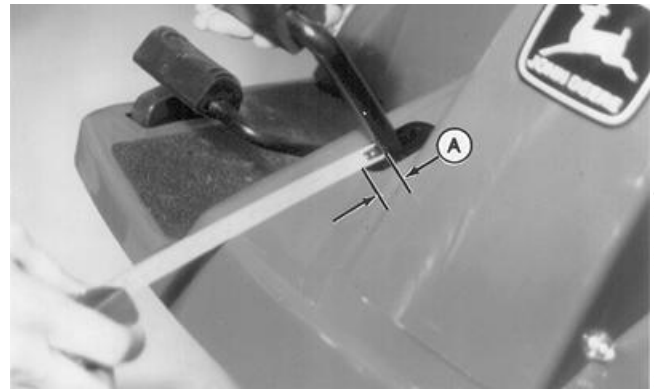

M52660
-UN-04AUG95

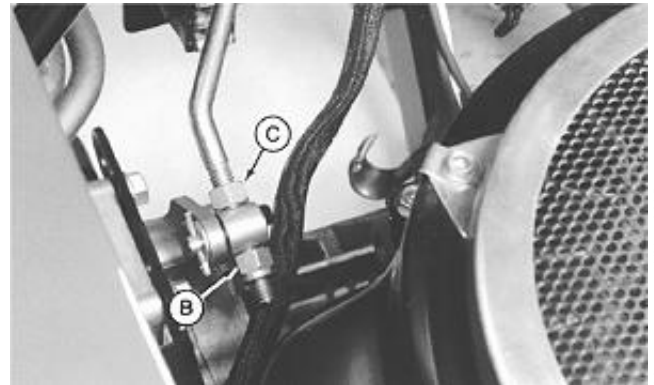

M62315
-UN-13MAR89

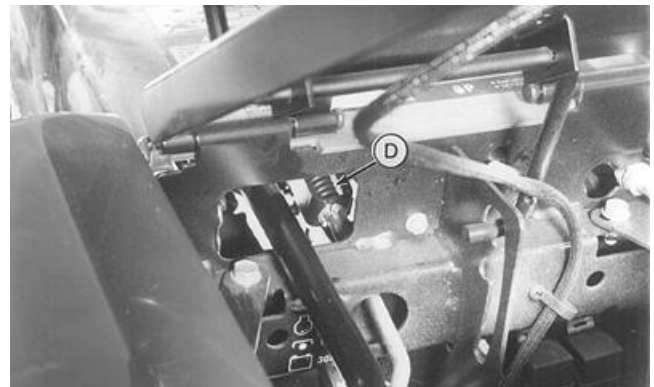

M83020
-UN-04AUG95

MX,26015CL,A4 -19-23OCT95

265
20
1

Adjustments/Brake Pedal Travel Adjustment

265
20
2

Section 280

MISCELLANEOUS OPERATION, TESTS, AND ADJUSTMENTS

Contents

Page

Group 05—Component Location

Weight Transfer System Component Location	280-05-1
--------------------------------------------------------	----------

Group 10—Theory of Operation

Weight Transfer System Operation	280-10-1
--------------------------------------------	----------

Group 15—Diagnosis and Adjustments—Snowthrower

Diagnostic Information	280-15-1
Lift Height Adjustment	280-15-8
Upstop Adjustment	280-15-9
Spout Adjustment	280-15-10
Runner Adjustment	280-15-11
Chain Tension Adjustment	280-15-12
Worm Gear Adjustment	280-15-14

Group 20—Diagnosis—Power Flow™ Blower Assembly

Diagnostic Information	280-20-1
Diagnostic Information	280-20-2
Diagnostic Information	280-20-4

280

WEIGHT TRANSFER SYSTEM COMPONENT LOCATION

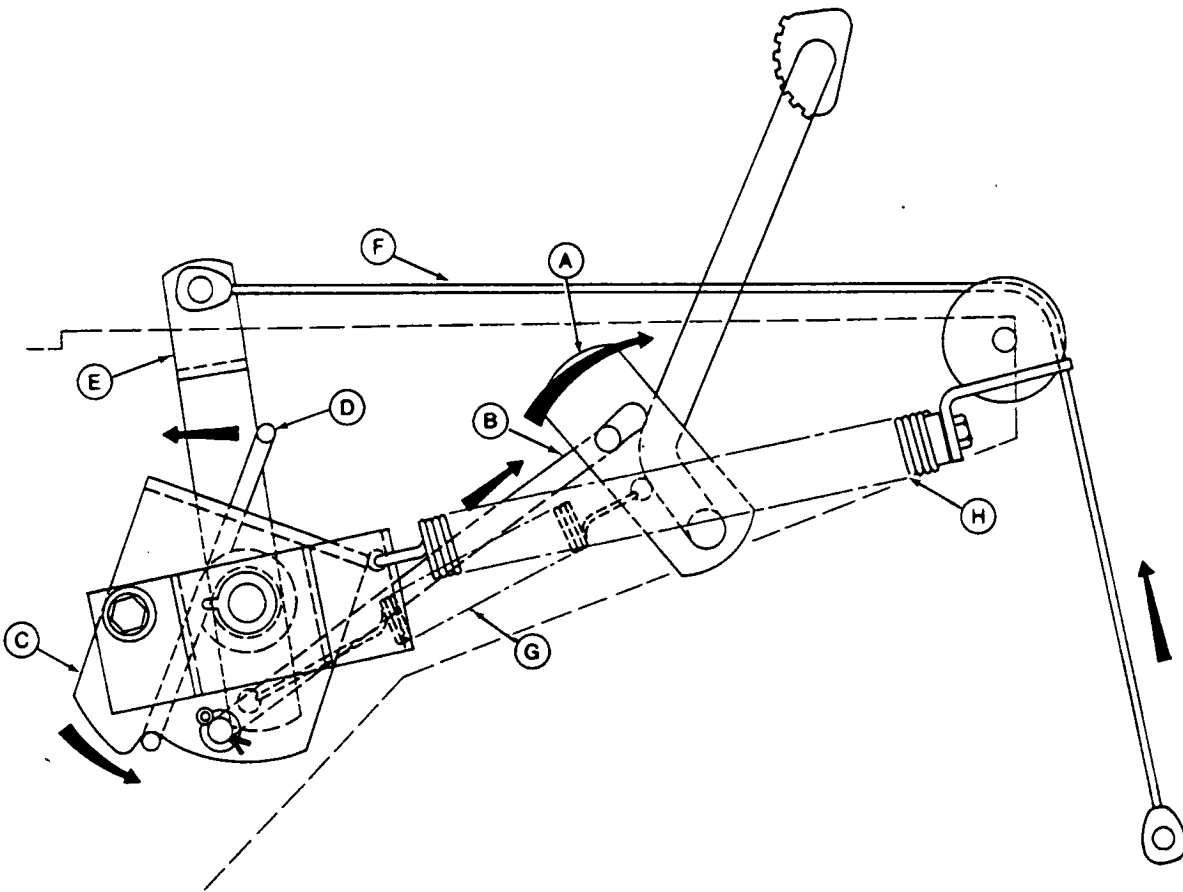

A—Cable
B—Pedal Arm

C—Assist Spring
D—Return Spring

E—Link Rod
F—Torsion Spring

G—Cable Arm
H—Torsion Spring Plate

M53041
-UN-05APR89

280
05
1

MX,28005CL,A1 -19-23OCT95

280
05
2

WEIGHT TRANSFER SYSTEM OPERATION

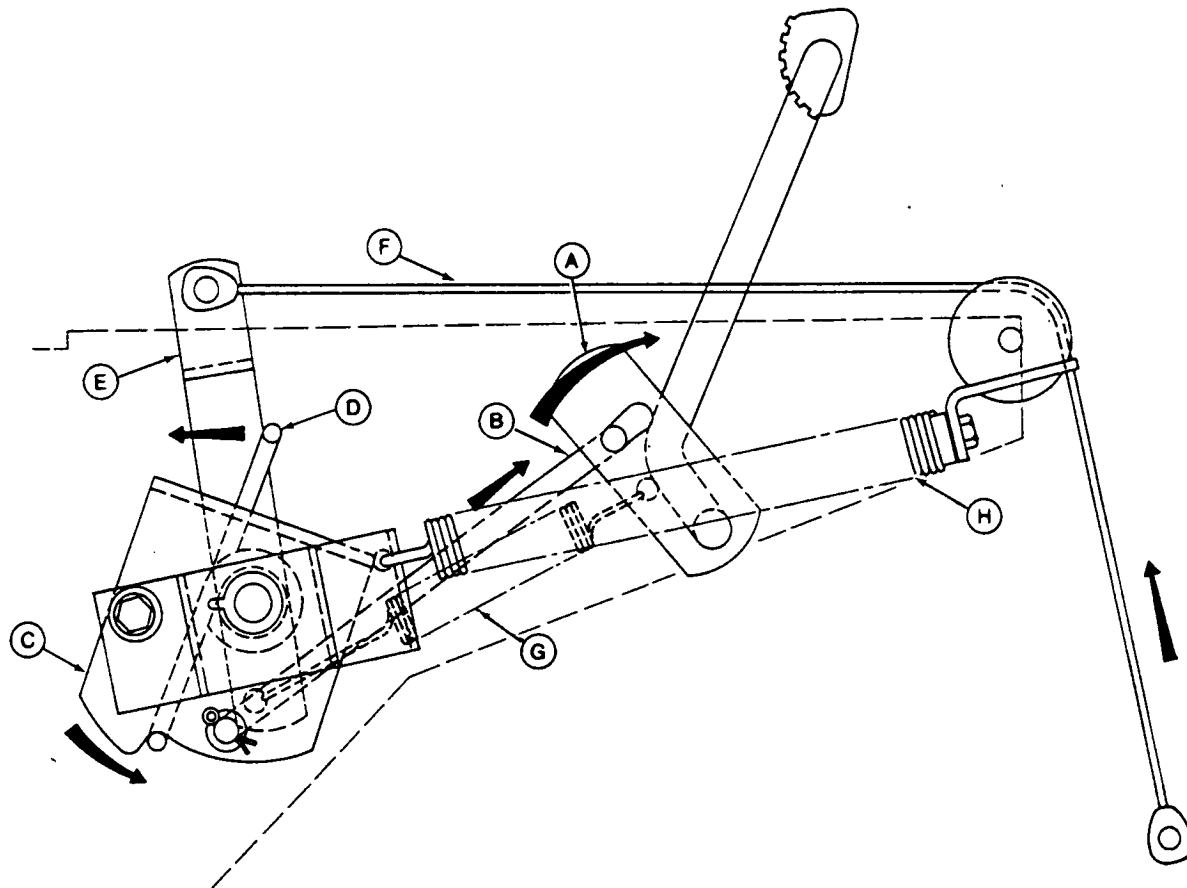

A—Pedal Arm
B—Link Rod

C—Torsion Spring Plate
D—Torsion Spring

E—Cable Arm
F—Cable

G—Return Spring
H—Assist Spring

The weight transfer system allows up to 60% of the mower weight to be transferred to the drive wheels during limited traction situations. The amount of weight transferred varies, depending on how far the weight transfer pedal is depressed.

To provide a more equal weight transfer when mowing at different mowing heights, the position of the cable where it attaches to the deck can be changed. Use the top hole when mowing between 25 and 57 mm (1 and 2.25 in.), and the bottom hole when mowing between 57 and 89 mm (2.25 and 3.50 in.) and for machines (S.N. 130001—), between 57 and 100 mm (2.25 and 4.00 in.).

When the pedal is depressed, pedal arm (A) is rotated forward. This pulls link rod (B) forward, rotating torsion spring plate (C). Plate (C) winds up torsion spring (D) putting rearward force on cable arm (E), causing it to rotate rearward. Cable (F) is attached to the top of this arm and mower deck resulting in the weight transfer. Return spring (G) eliminates cable and/or pedal tolerance. Spring (H) assists the operator, reducing the pressure required to wind up torsion spring (D).

M53041 -UN-05APR89

280
10

280
10
2

DIAGNOSTIC INFORMATION

The diagnostic information in this group is used to test components related to a specific problem. Select the appropriate symptom from the list that best matches your problem and follow the test procedures under that heading. The symptom headings are:

- Auger does not rotate or rotates erratically
- Chute does not rotate
- Snowthrower does not lift or lift properly

The diagnostic procedure lists:

- Test conditions
- Test sequence
- Test location
- Normal reading
- Check or test to perform if reading is not normal

When performing the test or check, be sure to set your machine up to the test conditions listed and follow the sequence carefully. The middle "NORMAL" column gives the specification or condition that should be obtained when performing the test or check. If the results are not normal, perform the test, check, or adjustment listed in the third "IF NOT NORMAL" column to repair the malfunction. The detailed tests or adjustments referred to in the "IF NOT NORMAL" column are located at the end of this group.

The system diagram that accompanies each test procedure shows the machine components. The key number on the art matches the number in the "TEST LOCATION" column and the arrow shows the exact point where the test is to be made.

MX,28015CL,G -19-23OCT95

280
15
1

AUGER DOES NOT ROTATE OR ROTATES ERRATICALLY

Conditions:

- Key switch in OFF position
- Park brake engaged
- PTO disengaged

Test Location	Normal	If Not Normal
1. Drive belt	Not worn, stretched or broken	Replace belt.
2. Key—drive sheave	Not missing or broken	Replace key.
3. Countershaft	Properly lubricated	Lubricate.
4. Bushings—countershaft	Not worn or damaged	Replace bushings.
5. Sprocket—countershaft	Not worn or damaged	Replace countershaft.
6. Chain	Adjusted to specifications	Perform Chain Tension Adjustment in this group.
	Not worn, stretched or damaged	Replace chain.
7. Sprocket—auger	Not worn or damaged	Replace sprocket.
8. Key—auger sprocket	Not missing or broken	Replace key.
9. Ball Bearings—auger	Not worn or damaged	Replace bearings.

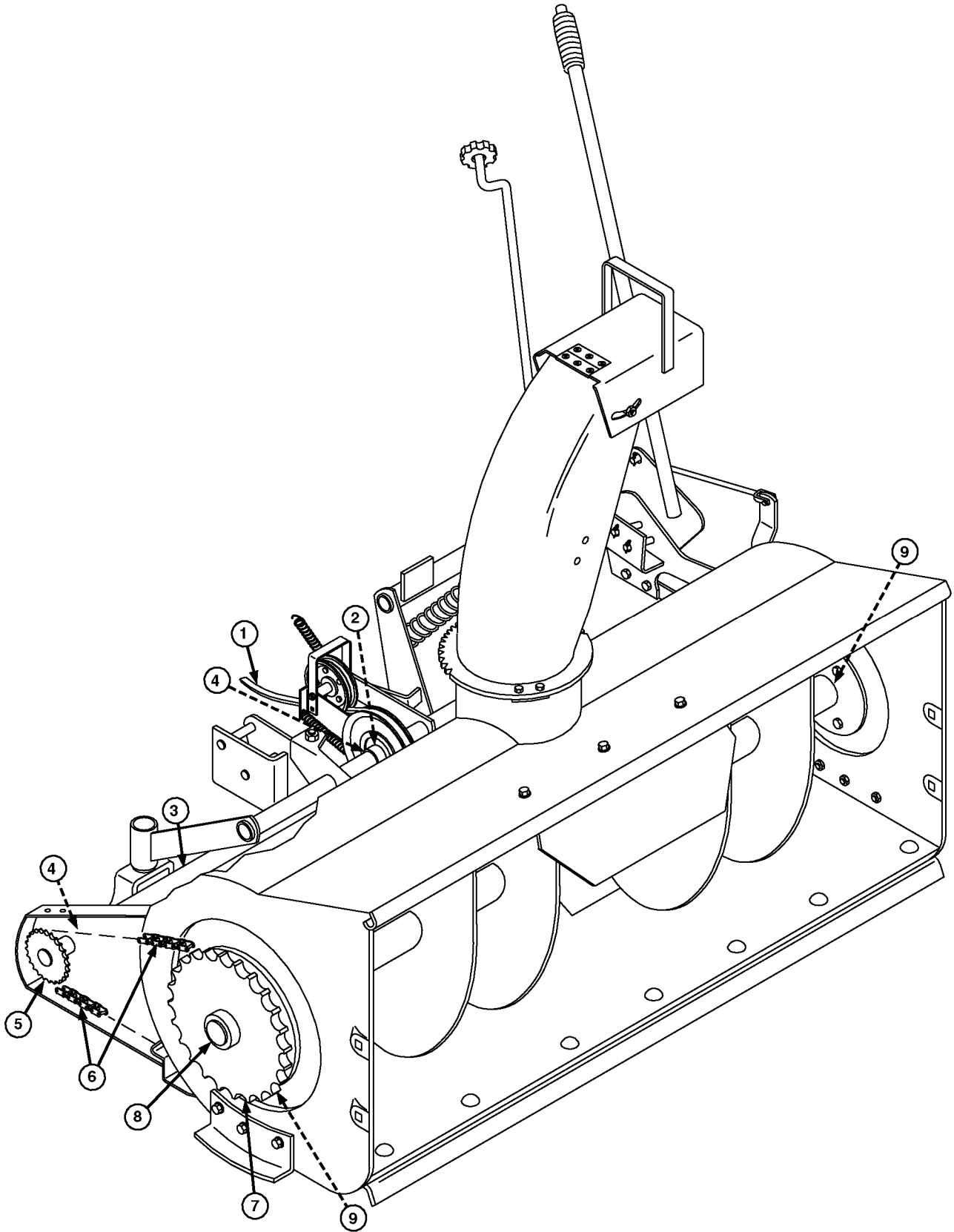

280
15
3

MB3040 -JUN-25AUG95

MX,28015CL,I -19-23OCT95

CHUTE DOES NOT ROTATE

Conditions:

- Key switch in OFF position
- Park brake engaged
- PTO disengaged

Test Location	Normal	If Not Normal
1. Gear—chute	Not worn or damaged	Replace chute assembly.
2. Worm gear	Not worn or damaged	Replace worm gear.
	Roll pin not damaged or missing	Replace roll pin.
	Properly adjusted	Perform Worm Gear Adjustment in this group.
Electric Spout Rotation Kit:		
3. Motor	Gears not worn or broken	Replace motor and/or drive rod.
4. Wiring harness	All connections correct and intact	Make proper connections.
5. Fuse	Not blown or missing	Replace fuse.
6. Switch	Functioning correctly	Replace switch.
7. Relay	Functioning correctly	Replace relay.

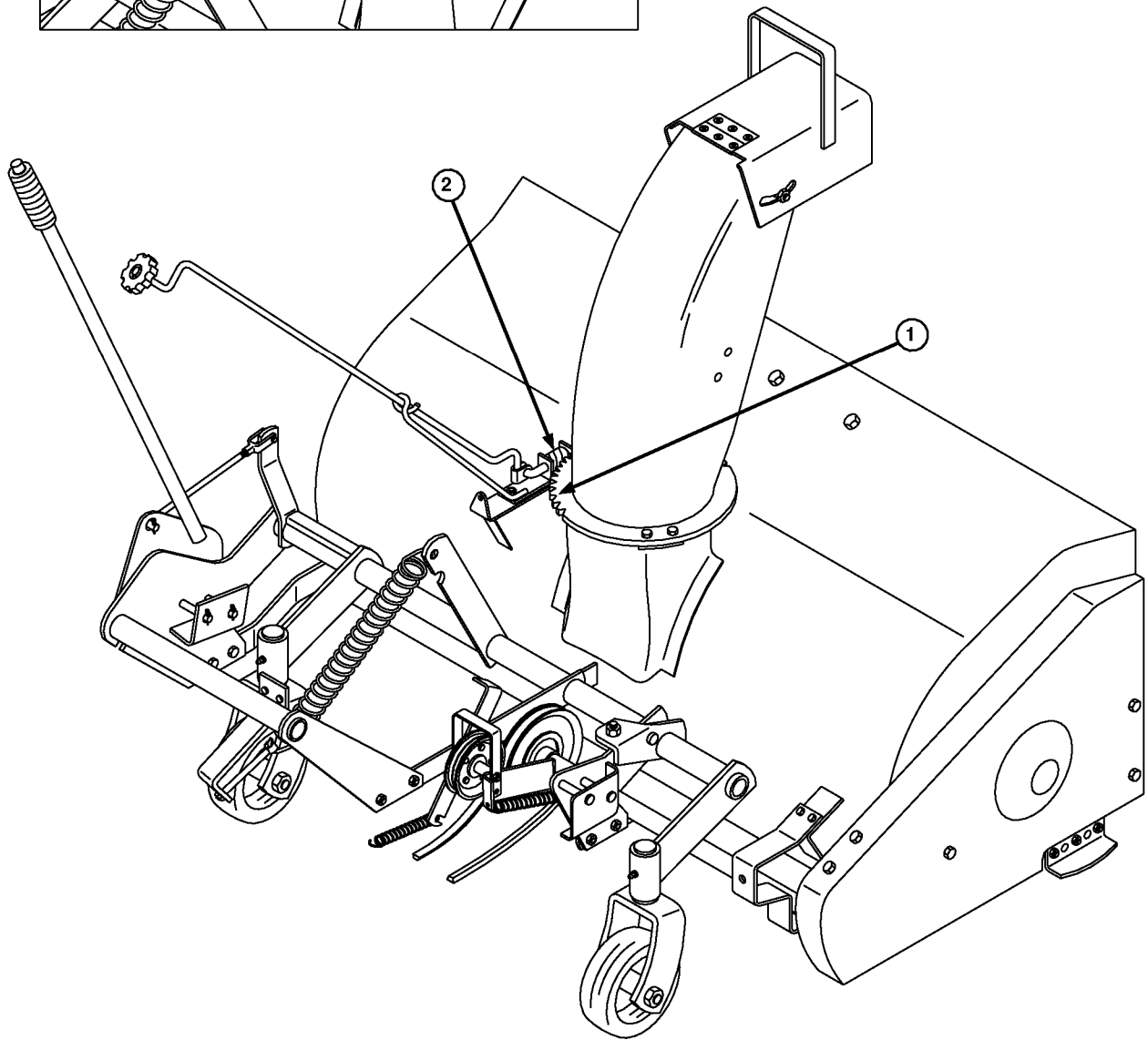
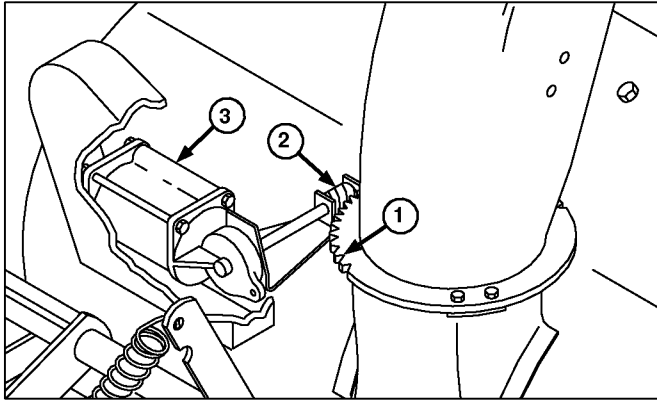

280
15
5

MB3041 -JUN-05SEF95

MX.28015CL,K -19-23OCT95

TM1475 (23OCT95)

280-15-5

F510/F525 Front Mowers

131295
PN=498

SNOWTHROWER DOES NOT LIFT PROPERLY

Conditions:

- Key switch in OFF position
- Park brake engaged
- PTO disengaged

Test Location	Normal	If Not Normal
1. Lift linkage	Adjusted properly—allows 102 ±6 mm (4 ±0.25 in.) clearance when locked in transport position. Not damaged	Perform Lift Height Adjustment in this group. Replace damaged parts.
2. Lift rockshaft	Not bent or damaged	Replace rockshaft.
3. Upstop	Adjusted properly—does not lock in raised position.	Perform Upstop Adjustment in this group.
4. Springs	Not stretched or broken	Replace springs.

MX,28015CL,L -19-23OCT95

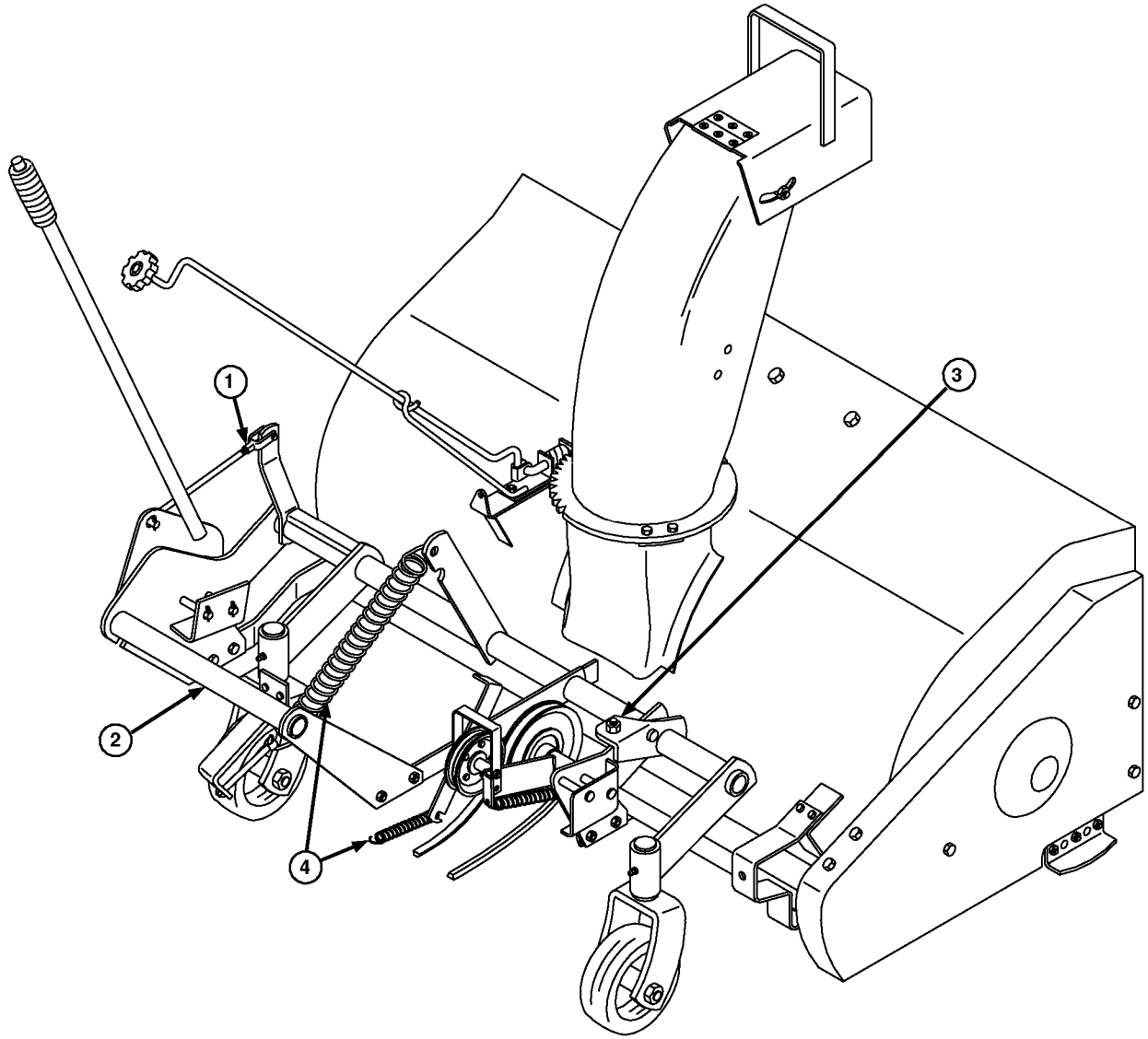

280
15
7

MX28015CLM -19-23OCT95

M83042

MX.28015CL.M -19-23OCT95

SNOWTHROWER LIFT HEIGHT ADJUSTMENT

Reason:

To provide correct ground clearance when snowthrower is in **transport** position.

Procedure:

1. Put transmission in **neutral**.
2. Engage park brake.
3. Turn key switch to **OFF** position.
4. Raise snowthrower and lock in **transport** position.
5. Check clearance (A) from bottom of auger housing to ground. Adjust if clearance is not within **102 ±6 mm (4 ±0.25 in.)**.
6. Lower snowthrower to ground.
7. Remove spring locking pin (B) and drilled pin (C).
8. Disconnect lift rod (D).
9. Turn clevis until **28 mm (1.10 in.)** of threads are exposed:
 - Turn clevis counterclockwise to expose more threads (decrease lift height).
 - Turn clevis clockwise to expose fewer threads (increase lift height).
10. Install lift rod (D) and fasten with drilled pin (C) and spring locking pin (B).

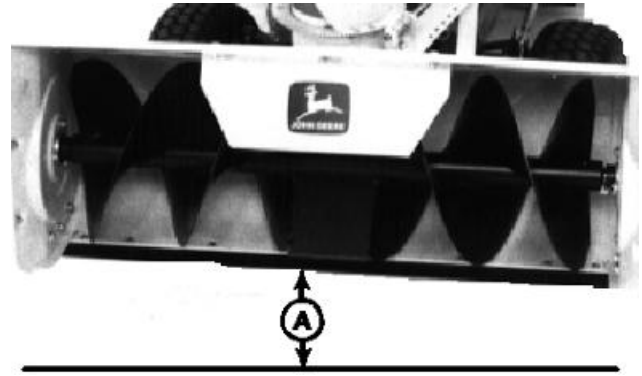

-UN-16AUG95

M83031

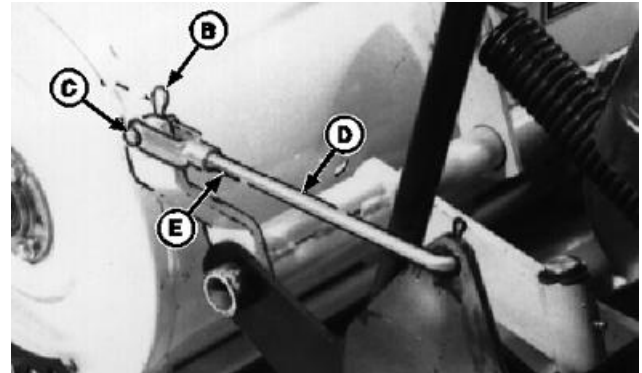

-UN-16AUG95

M83032

- A—Clearance 101—107 mm (3.75—4.25 in.)
- B—Spring Locking Pin
- C—Drilled Pin
- D—Lift Rod
- E—Exposed Threads

MX,28015CL,A -19-23OCT95

280
15
8

UPSTOP ADJUSTMENT

Reason:

To ensure proper operation of lift handle and latch.

Procedure:

1. Put transmission in **neutral**.
2. Engage park brake.
3. Turn key switch to **OFF** position.
4. Raise snowthrower.
5. Loosen nuts (A).
6. Adjust bolt (B) within **2—5 mm (0.079—0.197 in.)** of rockshaft arm (C).
7. Tighten nuts (A).
8. Raise and lower snowthrower to check for proper operation of lift handle. If handle is too hard to latch, adjust bolt (B) for additional clearance to rockshaft arm.

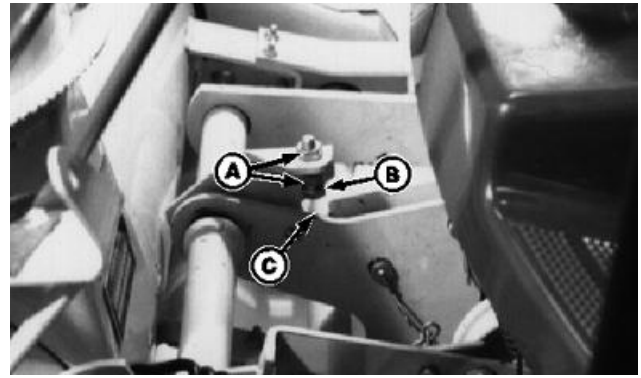

M85033 -UN-16AUG95

MX.28015CL,B -19-23OCT95

280
15
9

SPOUT ADJUSTMENT

Reason:

To make sure that the spout holds position when blowing snow.

Procedure:



CAUTION: Before adjusting spout:

- **STOP** snowthrower.
- **STOP** engine.
- **Lower** snowthrower to ground.
- **LOCK** parking brake.
- **Remove** key.
- **Wait** for auger to **STOP**.

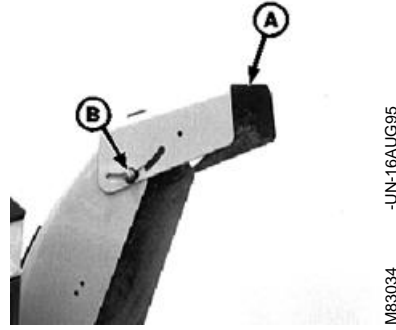

-UN-16AUG95

M83034

1. Turn engine **OFF**.
2. Lower snowthrower to ground.

*NOTE: Spout **MUST BE** tight enough to stay in position when snow from auger hits it, but also loose enough to move by hand.*

3. Grasp spout (A) and move to desired position, resistance should be felt.
4. If resistance is not felt or if spout does not hold position when in use, tighten lock nuts (B).

RUNNER ADJUSTMENT

Reason:

To maintain proper ground clearance for varying surface conditions.

Procedure:

1. Put transmission in **neutral**.
 2. Engage park brake.
 3. Turn key switch to **OFF** position.
 4. Raise snowthrower. Place wood block under auger housing.
- NOTE: Lower runners fully when using snowthrower on gravel or uneven surfaces. Raise runners when using snowthrower on smooth surfaces. Scraper blade **MUST NOT** contact ground.*
5. Loosen three cap screws (A). Move runners to desired position.
 - Adjust to **6 mm (0.25 in.)** when removing snow from smooth surfaces.
 - Adjust to **19 mm (0.75 in.)** when removing snow from uneven or gravel surfaces.
 6. Tighten cap screws.

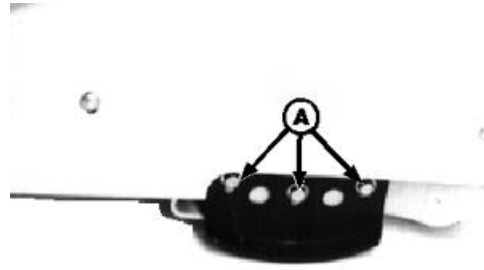

-JUN-16AUG95

M85035

MX,28015CL,D -19-23OCT95

280
15
11

CHAIN TENSION ADJUSTMENT

Reason:

Maintaining proper chain tension ensures maximum performance and minimizes chain and sprocket wear.

Procedure:

1. Put transmission in **neutral**.
2. Engage park brake.
3. Disengage PTO.
4. Turn key switch to **OFF** position.
5. Lower snowthrower to ground.
6. Remove bolts (B) and shield (A).
7. Place a straight edge against top of chain and apply pressure at midpoint between sprockets. Adjust chain tension if deflection (C) is more than **3—6 mm (0.125—0.250 in.)**.

A—Shield
B—Bolts
C—Chain Deflection 3—6 mm (0.125—0.250 in.)

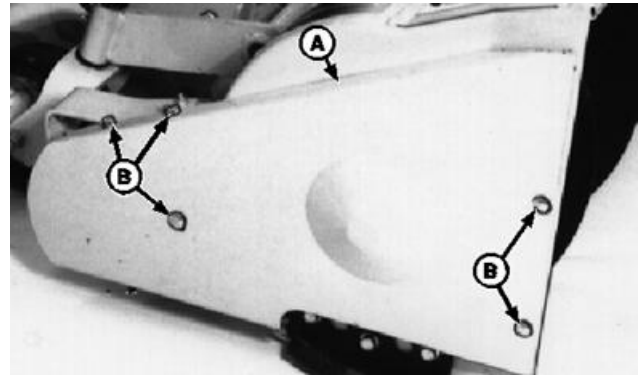

M83036 -JUN-16AUG95

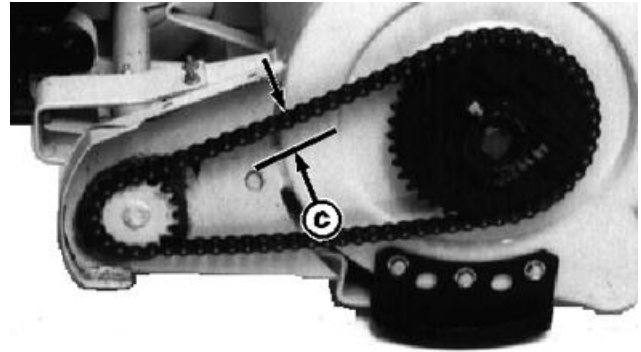

M83037 -JUN-16AUG95

8. Loosen nuts (D) and lock nut (E).

9. Turn bolt (F) until deflection is **3—6 mm (0.125—0.250 in.)**.

10. Tighten nuts (D) and lock nut (E).

IMPORTANT: Countershaft (G) must be parallel to snowthrower housing. If not, loosen nuts (D and E) and adjust.

11. Replace shield.

D—Nuts
E—Lock Nut
F—Bolt
G—Countershaft

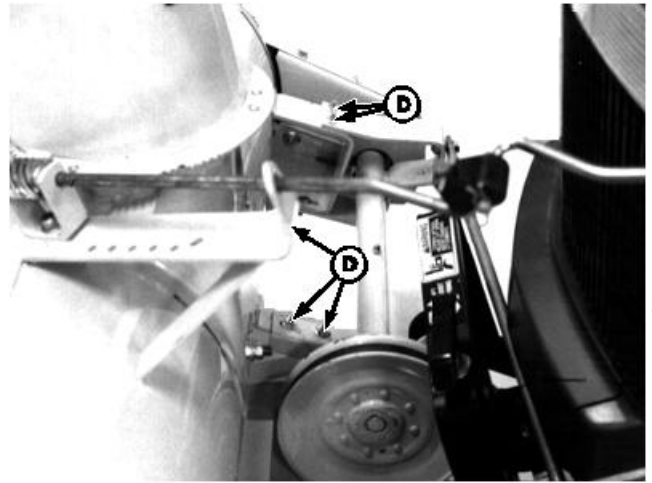

M83048 -UN-22SEP95

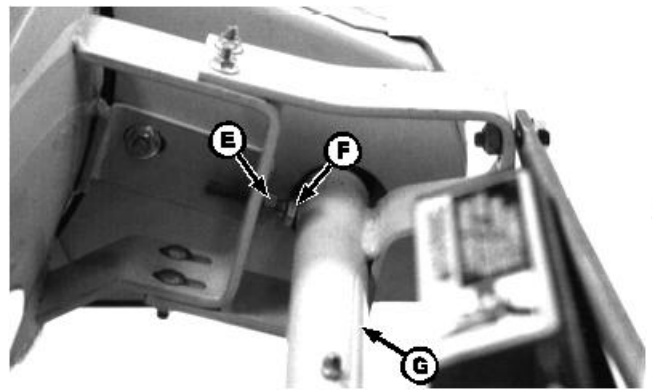

M83049 -UN-22SEP95

MX,28015CL,E1 -19-23OCT95

280
15
13

WORM GEAR ADJUSTMENT

Reason:

To make sure gear mesh correctly for smooth spout rotation.

Procedure:

1. Put transmission in **neutral**.
2. Engage park brake.
3. Turn key switch to **OFF** position.
4. Lower snowthrower to ground.
5. Loosen nuts (B).
6. Position worm gear so grooves on gear mesh with teeth on discharge spout.

NOTE: Spout should rotate freely when turning crank handle.

7. Tighten nuts (B).

NOTE: If snowthrower spout rotates on its own while blowing snow, turn nut (A) under black tension block up to adjust tension.

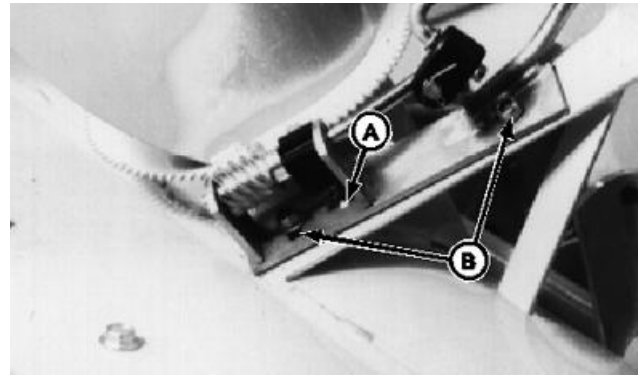

M85039 -UN-16AUG95

DIAGNOSTIC INFORMATION

The diagnostic information in this group is used to test components related to a specific problem. Select the appropriate symptom from the list that best matches your problem and follow the test procedures under that heading. The symptom headings are:

- Excessive noise and/or vibration
- Rotor does not rotate or does not rotate at proper speed

The diagnostic procedure lists:

- Test conditions
- Test sequence
- Test location
- Normal reading
- Check or test to perform if reading is not normal

When performing the test or check, be sure to set your machine up to the test conditions listed and follow the sequence carefully. The middle "NORMAL" column gives the specification or condition that should be obtained when performing the test or check. If the results are not normal, perform the test, check, or adjustment listed in the third "IF NOT NORMAL" column to repair the malfunction. The detailed tests or adjustments referred to in the "IF NOT NORMAL" column are located at the end of this group.

The system diagram that accompanies each test procedure shows the machine components. The key number on the art matches the number in the "TEST LOCATION" column and the arrow shows the exact point where the test is to be made.

MX,28020CL,C -19-23OCT95

280
20
1

EXCESSIVE NOISE AND/OR VIBRATION

Conditions:

- Key switch in OFF position
- Park brake engaged
- PTO disengaged

NOTE: Assembly for 48-inch mower deck shown, other assemblies are similar.

Test Location	Normal	If Not Normal
1. Bearings	Not worn or damaged	Replace bearings.
2. Rotor	Not worn or damaged	Replace rotor.
3. Bushings—idler sheaves	Not worn	Replace bushings.
4. Drive sheave	Not bent	Replace drive sheave.

MX,28020CL,A -19-23OCT95

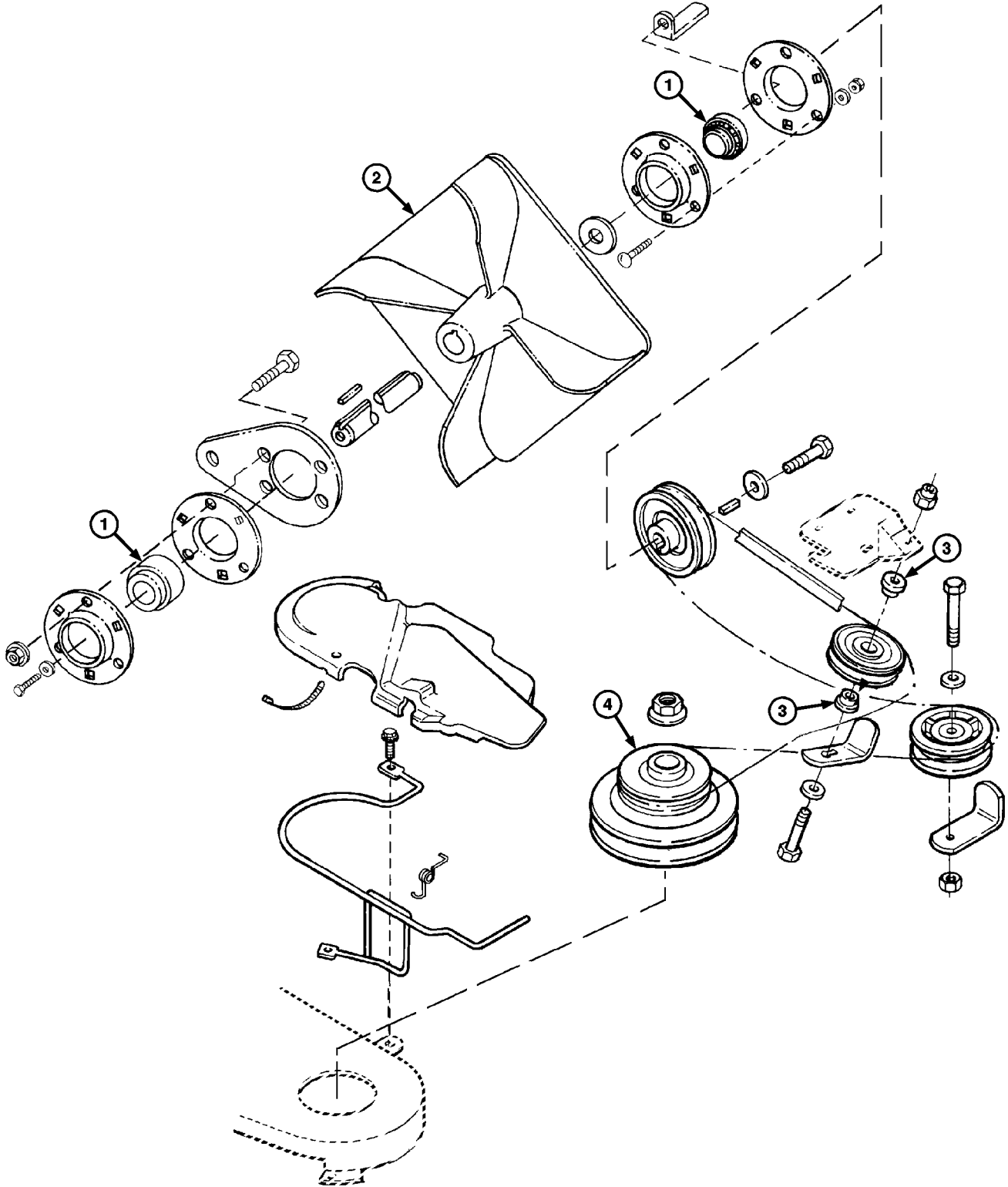

280
20

MB3046 -JUN-22SEP95

MX.28020CL.A1 -19-23OCT95

ROTOR DOES NOT ROTATE OR DOES NOT ROTATE AT PROPER SPEED

Conditions:

- Key switch in OFF position
- Park brake engaged
- PTO disengaged

NOTE: Assembly for 48-inch mower deck shown, other assemblies are similar.

Test Location	Normal	If Not Normal
1. Bearings	Not binding	Replace bearings.
2. Key—rotor	Not damaged or missing	Replace key.
3. Keys—drive sheave	Not damaged or missing	Replace key.
4. Drive belt	Not worn, stretched or broken	Replace drive belt.

MX.28020CL,B -19-23OCT95

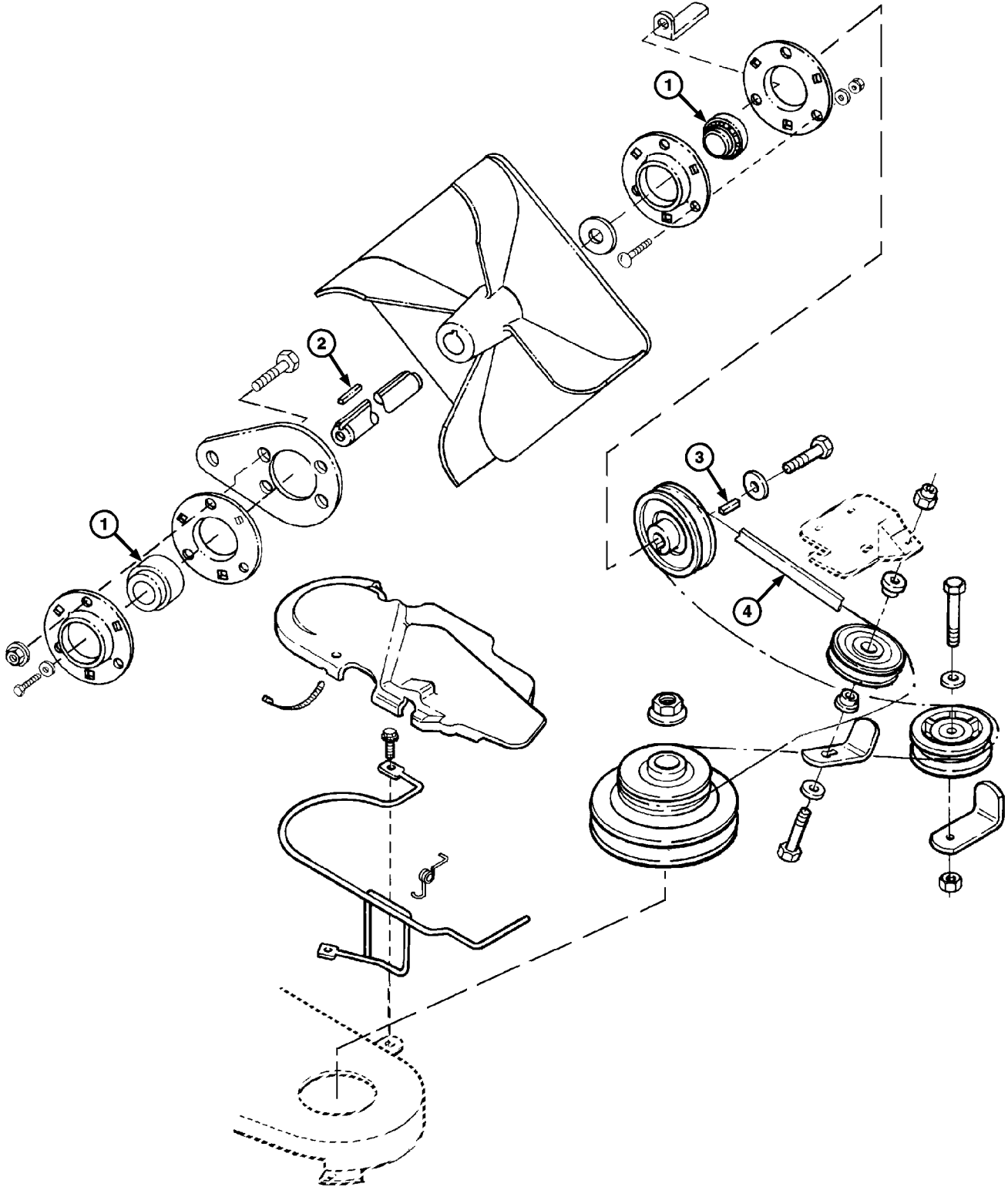

280
5120

MB3047 -JUN-22SEP95

MX.28020CL,B1 -19-23OCT95

280
20
6

Index

	Page		Page
A			
Air cleaner check	210-05-2	Brake system	
Air cleaner, service	30-15-1	Components	265-05-1
Air intake system	230-10-14	Test points	265-15-1
Air system components	230-05-2	Breather	
Alternative lubricants	10-20-9	Service	30-20-11
Anti-cavitation valve operation	250-10-12	Breather system operation	220-10-8
Anti-cavitation valves		Brush holder, test	40-10-7
Disassemble and inspect	50-10-8	C	
Armature		Camshaft	
Adjust air gap	40-15-2	Inspect	20-20-5
Remove and install	40-15-1	Inspect bearings	20-20-6
Armature rotation, check	40-10-3	Remove and install	20-20-4
Auger does not rotate or rotates		Camshaft features	220-10-2
erratically	280-15-2	Carburetor—PA420A	
Automatic compression release	220-10-12, 220-15-37	Disassemble, inspect and assemble	30-20-6
Automatic compression release		Remove and install	30-20-2
Inspect	20-20-7	Carburetor—PA540A	
Axle assemblies		Disassemble, inspect and assemble	30-20-8
Remove and install	50-10-14	Remove and install	30-20-4
Axle assembly		Charge pump Inspect	50-10-4
Inspect	50-10-14	Charge relief valves	
Axle housing		Assemble	50-10-9
Inspect	50-10-23	Disassemble and inspect	50-10-8
B			
Balancer bushings, replace		Charging circuit test points	240-15-32, 240-15-34
PA420A/PA540A-AS00, BS00, AS01	20-20-11	Charging system operation	240-10-12
Battery charge	240-15-46	Checkout procedure complete	210-05-9
Battery load test	240-15-47	Choke adjustment	220-15-27
Battery test	240-15-45	Choke circuit operation	230-10-8
Belt		Choke lever check	210-05-6
Remove and install	80-10-1	Chute does not rotate	280-15-4
Blower housing		Common circuit tests	
Remove and install	20-10-2	Grounded circuit	240-15-44
Blower Housing		High resistance or open circuit	240-15-44
Repair (46-Inch Mower Deck)	80-20-6	Shorted circuit	240-15-44
Repair (48-Inch Mower Deck)	80-20-8	Component location information	
Brake band		Electrical	240-05-1
Remove and install	65-05-1	Engine	220-05-1
Brake linkage operation	265-10-1	Fuel and air	230-05-1
Brake pedal lock check	210-05-8	Compression leak check	220-15-35
Brake pedal travel adjustment	265-20-1	Configuration chart, engine	10-15-1, 20-10-1, 20-15-1, 20-20-1, 30-20-1, 50-10-1
Brake switch safety circuit check	210-05-4	Connecting rod	
Brake switch test and adjustment	240-15-62	Disassemble, inspect and assemble	20-20-13
		Inspect	20-20-20
		Remove and install	20-20-12
		Connecting rod, analyze wear	20-20-21
		Control lever shaft Inspect	50-10-12
		Cooling system	220-10-10

	Page
Electrical diagnosis—Continued	
Low fuel light—F510 (011958—100000)	240-15-38
Low fuel light—F510 (100001—)	240-15-40
Low fuel light—F525 (012520—100000)	240-15-38
Low fuel light—F525 (100001—)	240-15-40
Magneto/ground circuit test points	240-15-14, 240-15-16, 240-15-18, 240-15-20
Oil light test—F510 (011958—100000)	240-15-38
Oil light test—F510 (100001—)	240-15-40
Oil light test—F525 (012520—100000)	240-15-38
Oil light test—F525 (100001—)	240-15-40
Oil pressure light—F510 (—011957	240-15-36
Oil pressure light—F525 (—012519	240-15-36
PTO circuit—F510 (—011957)	240-15-24, 240-15-26
PTO circuit—F510 (011958—)	240-15-28, 240-15-30
PTO circuit—F525 (—012519)	240-15-24, 240-15-26
PTO circuit—F525 (012520—)	240-15-28, 240-15-30
Electrical diagnostic information	240-15-1
Electrical schematic	
F510 (—011957)	240-20-3
F510 (011958—)	240-20-7
F525 (—012519)	240-20-3
F525 (012520—)	240-20-7
Electrical schematic information	240-20-1
Electrical schematic legend	
F510 (—011957)	240-20-2
F510 (011958—)	240-20-6
F525 (—012519)	240-20-2
F525 (012520—)	240-20-6
Electrical system components	240-05-2
Electrical tests	
Battery	240-15-45
Battery charge	240-15-46
Battery load	240-15-47
Brake switch	240-15-62
Common circuit	240-15-44
Flywheel magnet	240-15-61
Fuel shut-off solenoid	240-15-71
Ground circuit	240-15-74
Headlight switch	240-15-69
Ignition coil—F510 (—100203)	240-15-55
Ignition coil—F510 (100204—)	240-15-56
Ignition coil—F525 (—100392)	240-15-55
Ignition coil—F525 (100393—)	240-15-56
Ignition module	240-15-56
Key switch	240-15-60

	Page
Electrical tests—Continued	
Low fuel sensor	240-15-73
Oil pressure sender switch	240-15-70
PTO clutch	240-15-66
PTO switch-F510 (—011957)	240-15-63
PTO switch-F510 (011958—120459)	240-15-64
PTO switch-F510 (120460—)	240-15-65
PTO switch-F525 (—012519)	240-15-63
PTO switch-F525 (012520—1212629)	240-15-64
PTO switch-F525 (121630—)	240-15-65
Regulated amperage	240-15-48
Regulated voltage	240-15-49
Relay	240-15-72
Seat switch	240-15-68
Spark	240-15-59
Spark plug cap—F510 (—100203)	240-15-57
Spark plug cap—F525 (—100392)	240-15-57
Starter amp draw	240-15-52
Starter no-load amperage and rpm	240-15-53
Starter solenoid	240-15-51
Unregulated voltage output	240-15-50
Electrical theory	
Charging system	240-10-12
Cranking system-F510 (—011957)	240-10-2
Cranking system-F525 (—012519)	240-10-2
Cranking system—F510 (011958—)	240-10-4
Cranking system—F525 (012520—)	240-10-4
Headlight system	240-10-16
Hourmeter system	240-10-16
Ignition circuit operation—on seat	240-10-6
Ignition system—F510 (—011957)	240-10-8
Ignition system—F525 (—012519)	240-10-8
Ignition system—510 (011958—)	240-10-10
Ignition system—525 (012520—)	240-10-10
Low fuel light system	240-10-16
Oil pressure light system	240-10-16
PTO system operation-on seat	240-10-14
Wire color chart	240-10-1
Electrical theory of operation information	240-10-1
Engine	
Install	20-05-4
Performance check	210-05-6
Remove	20-05-1
Stop check	210-05-6
Test and adjustment specifications	210-10-1
Engine adjustments	
Automatic compression release	220-15-37
Choke	220-15-27
Fast idle speed	220-15-30
Governor	220-15-29

	Page		Page
Engine adjustments—Continued			
Slow idle speed—F510 (—100203)	220-15-31	Engine theory	
Slow idle speed—F510 (100204—)	220-15-32	Automatic compression release	220-10-12
Slow idle speed—F525 (—100392)	220-15-31	Breather system	220-10-8
Slow idle speed—F525 (100393—)	220-15-32	Camshaft	220-10-2
Throttle cable	220-15-26	Cooling system	220-10-10
Valve clearance	220-15-36	Crankshaft	220-10-2
Engine backfires through carburetor . . .	220-15-12	Engine description	220-10-1
Engine backfires through muffler	220-15-14	Lubrication circuit	220-10-6
Engine component location		Lubrication system	220-10-4
Exterior engine	220-05-2	Engine theory of operation information . . .	220-10-1
Internal engine	220-05-4	Engine uses too much oil	220-15-24
Engine component location information . .	220-05-1	Engine/Hydrostatic transmission oil	
Engine configuration chart	10-15-1, 20-10-1, 20-15-1, 20-20-1, 30-20-1, 50-10-1	Europe	10-20-4
Engine cranks but will not start	220-15-2	North America	10-20-3
Engine description	220-10-1	Excessive noise and/or vibration	280-20-2
Engine diagnosis		Exterior engine component location	220-05-2
Engine backfires through carburetor . .	220-15-12		
Engine backfires through muffler	220-15-14	F	
Engine cranks but will not start	220-15-2	Fast idle circuit operation	230-10-6
Engine flooding	220-15-4	Fast idle speed adjustment	220-15-30
Engine has black exhaust smoke	220-15-20	Features of engine components	
Engine has blue exhaust smoke	220-15-22	Crankshaft	220-10-2
Engine loses power when hot	220-15-18	Fenders	
Engine misses	220-15-16	Remove and install	80-25-3
Engine runs rough when hot	220-15-18	Field coil/brushes, test	40-10-7
Engine starts hard when hot	220-15-8	Fixed displacement motor	
Engine stops when hot	220-15-8	Assemble	50-10-24
Engine surging	220-15-10	Disassemble	50-10-19
Engine uses too much oil	220-15-24	Housing, inspect	50-10-20
Lack of fuel in carburetor	220-15-6	Float adjustment	30-20-10
Oil in air filter housing	220-15-22	Float operation	230-10-4
Engine diagnostic information	220-15-1	Flywheel	
Engine flooding	220-15-4	Remove and install	20-10-3
Engine has black exhaust	220-15-20	Flywheel magnet test	240-15-61
Engine has blue exhaust smoke	220-15-22	Flywheel screen adjustment	20-10-2
Engine loses power when hot	220-15-18	Forward Operation	250-10-8
Engine lubrication circuit	220-10-6	Free-wheeling valve	
Engine misses	220-15-16	Disassemble and assemble	50-10-26
Engine oil check	210-05-1	Inspect	50-10-26
Engine runs rough when hot	220-15-18	Free-wheeling valve operation	250-10-2
Engine serial number	10-25-1	Freewheel valve operation	
Engine starts hard or stops when hot . . .	220-15-8	Engagement	250-10-16
Engine surging	220-15-10	Pre-engagement	250-10-14
Engine tests		Fuel and air component location	
Compression leak check	220-15-35	Air system components	230-05-2
Crankcase vacuum	220-15-38	Fuel system components	230-05-2
Cylinder compression	220-15-34	Fuel and air diagnostic information	230-15-1
Fuel pump	220-15-41		
Oil pressure	220-15-40		

Page	Page
Fuel and air theory	F525 (012520—100000) wiring harness . . . 240-20-8
Air intake system 230-10-14	F525 (012520—100000) wiring harness legend 240-20-9
Choke circuit operation 230-10-8	F525 (100001—) wiring harness 240-20-11
Fast idle circuit operation 230-10-6	F525 (100001—) wiring harness legend 240-20-10
Float operation 230-10-4	F525 wiring harness with plug-in diodes (S.N. 100001—) 240-20-12
Fuel pump operation 230-10-10	F525 wiring harness with plug-in diodes (S.N. 100001—) legend 240-20-13
Fuel system operation 230-10-2	
Governor operation 230-10-12	G
Main jet circuit operation 230-10-4	Gasoline 10-20-1
Slow idle circuit operation 230-10-6	Gear reduction assembly operation 250-10-20
Fuel leak check 210-05-2	Governor
Fuel pump Remove and install 30-10-1	Inspect and replace 20-20-38
Fuel pump operation 230-10-10	Governor adjustment 220-15-29
Fuel pump test 220-15-41	Governor arm
Fuel shut-off solenoid test 240-15-71	Inspect and replace 20-20-39
Fuel shut-off solenoid test points 240-15-22	Governor operation 230-10-12
Fuel system components 230-05-2	Grease
Fuel system operation 230-10-2	Europe 10-20-8
Fuel tank, remove and install 30-05-1	North America 10-20-7
Fuel tank, repair 30-05-2	Ground circuit 240-15-44
Fuel/air component location information . . 230-05-1	Ground circuit test 240-15-74
Fuel/air theory of operation information . . 230-10-1	
Fuse block identification 240-15-2	H
F510 (—011957) electrical schematic . 240-20-3	Headlight circuit test points-optional 240-15-42
F510 (—011957) electrical schematic legend 240-20-2	Headlight switch test 240-15-69
F510 (—011957) wiring harness 240-20-4	Headlight system operation 240-10-16
F510 (—011957) wiring harness legend 240-20-5	High resistance or open circuit 240-15-44
F510 (011958—) electrical schematic . 240-20-7	Hopper Top and Mounting Bracket
F510 (011958—) electrical schematic legend 240-20-6	Repair 80-20-10
F510 (011958—100000) wiring harness . . 240-20-8	Hourmeter circuit test points
F510 (011958—100000) wiring harness legend 240-20-9	F510 (—011957) 240-15-36
F510 (100001—) wiring harness 240-20-11	F510 (011958—100000) 240-15-38
F510 (100001—) wiring harness legend 240-20-10	F510 (100001—) 240-15-40
F510 wiring harness with plug-in diodes (S.N. 100001—) 240-20-12	F525 (—012519) 240-15-36
F510 wiring harness with plug-in diodes (S.N. 100001—) legend 240-20-13	F525 (012520—100000) 240-15-38
F525 (—012519) electrical schematic . 240-20-3	F525 (100001—) 240-15-40
F525 (—012519) electrical schematic legend 240-20-2	Hourmeter system operation 240-10-16
F525 (—012519) wiring harness 240-20-4	Hydrostatic charge components 250-05-1
F525 (—012519) wiring harness legend 240-20-5	Hydrostatic circuit operation 250-10-4
F525 (012520—) electrical schematic . 240-20-7	Hydrostatic circuit operation
F525 (012520—) electrical schematic legend 240-20-6	Neutral operation 250-10-6
	Anti-cavitation valve 250-10-12

	Page		Page
Reciprocating balancer		Snowthrower	
Disassemble and assemble	20-20-9	Chain tension adjustment	280-15-12
Inspect	20-20-10	Lift height adjustment	280-15-8
Remove and install	20-20-8	Runner adjustment	280-15-11
Reduction gear assembly		Spout adjustment	280-15-10
Disassemble	50-10-15	Upstop adjustment	280-15-9
Regulated amperage test	240-15-48	Worm gear adjustment	280-15-14
Regulated voltage test	240-15-49	Snowthrower chute assembly	
Relay test	240-15-72	Repair	80-15-8
Repair specifications	10-15-2	Snowthrower diagnosis	280-15-2, 280-15-4, 280-15-6
Reverse operation	250-10-10	Snowthrower diagnostic information	280-15-1
Rocker arm assembly		Snowthrower does not lift properly	280-15-6
Inspect	20-15-3	Solenoid drive starter, test	40-10-2
Remove and install	20-15-3	Solenoid, test	40-10-3
Rotating group		Spark plug cap test	
Assemble	50-10-18	F510 (—100203)	240-15-57
Inspect	50-10-17	F525 (—100392)	240-15-57
Rotor		Spark plug gap adjustment	240-15-58
Repair (46-Inch Mower Deck)	80-20-1	Spark test	240-15-59
Repair (48-Inch Mower Deck)	80-20-2	Specification, repair	10-15-2
Rotor does not rotate or does not rotate at proper speed	280-20-4	Specifications	10-15-12
		Specifications	
		Machine	10-10-1
		Spindle assemblies	
		Remove and install	80-05-1
		Spindle assembly, 38-in.	
		Disassemble and assemble	80-05-2
		Spindle assembly, 46-in.	
		Disassemble and assemble	80-05-3
		Spindles—48 inch	
		Assemble	80-05-6
		Cross section	80-05-5
		Disassemble	80-05-4
		Springs, inspect	20-15-7
		Starter amp draw test	240-15-52
		Starter no-load amperage and rpm test	240-15-53
		Starter solenoid test	240-15-51
		Starting circuit checks	210-05-4
		Stator	
		Remove and install	40-15-1
		Steering check	210-05-8
		Steering linkage	
		Adjustment	260-20-1
		Operation	260-10-1
		Steering shaft/gears	
		Inspect	60-05-2
		Install	60-05-3
		Remove	60-05-1

S

Schematic information	240-20-1
Seat Platform	
Remove and install	80-25-1
Seat switch check	
Engine running	210-05-4
Seat switch test	240-15-68
Serial number information	10-25-1
Shorted circuit	240-15-44
Shroud	
Rear, remove and install	80-25-1
Slow idle circuit operation	230-10-6
Slow idle speed adjustment	
F510 (—100203)	220-15-31
F510 (100204—)	220-15-32
F525 (—100392)	220-15-31
F525 (100393—)	220-15-32
Snowthrower drive shaft assembly	
Repair	80-15-4
Snowthrower housing assembly Repair	80-15-6
Snowthrower lift assembly	
Repair	80-15-3
Snowthrower lift linkage	
Repair	80-15-2

	Page		Page
Steering system		Valve operation	
Components	260-05-1	Free-wheeling	250-10-2
Test points	260-15-1	Valve seats	
Stem seals		Recondition	20-15-13
Inspect and replace	20-15-6	Valves	
Swash plate		Analyze	20-15-9
Assemble	50-10-13	Inspect	20-15-8
Remove and disassemble	50-10-9	Lap	20-15-14
Swash plate assembly		Valves and springs	
Inspect	50-10-10	Remove and install	20-15-6
Synthetic lubricants	10-20-9		
		W	
T		Weight transfer check	210-05-8
Tappets		Weight transfer system	
Remove, inspect and install	20-20-7	Component location	280-05-1
Theory of operation information		Repair	80-30-1
Electrical	240-10-1	Weight Transfer System	
Engine	220-10-1	Repair	80-30-1
Fuel and air	230-10-1	Weight transfer system	
Throttle cable adjustment	220-15-26	Theory of operation	280-10-1
Throttle check	210-05-6	Wheels	
Torque values		Rear, repair	60-10-1
Inch	10-15-15	Remove and install	60-10-1
Metric	10-15-14	Wire color chart	240-10-1
Transaxle		Wiring harness	
Forward performance check	210-05-7	F510 (—011957)	240-20-4
Neutral check	210-05-7	F510 (011958—100000)	240-20-8
Neutral return check	210-05-7	F510 (100001—)	240-20-11
Reverse performance check	210-05-7	F525 (—012519)	240-20-4
Transaxle Components	250-05-4	F525 (012520—100000)	240-20-8
Transaxle control linkage components . . .	250-05-6	F525 (100001—)	240-20-11
Transaxle oil check	210-05-1	Wiring harness legend	
Tune-up adjustments	10-15-13	F510	240-20-13
Tune-up specifications	10-15-12	F510 (—011957)	240-20-5
		F510 (011958—100000)	240-20-9
U		F510 (100001—)	240-20-10
Unregulated voltage output test	240-15-50	F525	240-20-13
		F525 (—012519)	240-20-5
V		F525 (012520—100000)	240-20-9
Valve clearance		F525 (100001—)	240-20-10
Check	20-15-14	Wiring harness with plug-in diodes	
Valve clearance adjustment	220-15-36	F510	240-20-12
Valve guide bushings		F525	240-20-12
Replace	20-15-11		
Valve guides		4	
Inspect	20-15-11	48 Inch spindle cross section	80-05-5

