

JOHN DEERE
WORLDWIDE COMMERCIAL & CONSUMER
EQUIPMENT DIVISION

John Deere Select Series™ Tractors
X300 Series

TM2308 JANUARY 2011

TECHNICAL MANUAL



JOHN DEERE

North American Version
Litho In U.s.a.

INTRODUCTION

Manual Description

This technical manual is written for an experienced technician and contains sections that are specifically for this product. It is a part of a total product support program.

The manual is organized so that all the information on a particular system is kept together. The order of grouping is as follows:

- Table of Contents
- Specifications and Information
- Identification Numbers
- Tools and Materials
- Component Location
- Schematics and Harnesses
- Theory of Operation
- Operation and Diagnostics
- Diagnostics
- Tests and Adjustments
- Repair
- Other

Note: Depending on the particular section or system being covered, not all of the above groups may be used.

The bleed tabs for the pages of each section will align with the sections listed on this page. Page numbering is consecutive from the beginning of the Safety section through the last section.

We appreciate your input on this manual. If you find any errors or want to comment on the layout of the manual please contact us.

Safety

Specifications and Information

Engine (FH491)

Engine (FH661 and FH721)

Engine - (FS541V)

Electrical

Power Train

Hydraulics

Steering

Attachments

Miscellaneous

All information, illustrations and specifications in this manual are based on the latest information at the time of publication. The right is reserved to make changes at any time without notice.

COPYRIGHT© 2011

Deere & Co.

John Deere Ag & Turf Division

All rights reserved

Previous Editions

COPYRIGHT© 2006, 2007, 2008, 2009

SAFETY

Recognize Safety Information



MIF

This is the safety-alert symbol. When you see this symbol on your machine or in this manual, be alert to the potential for personal injury.

Follow recommended precautions and safe servicing practices.

Understand Signal Words

A signal word - DANGER, WARNING, or CAUTION - is used with the safety-alert symbol. DANGER identifies the most serious hazards.

DANGER or WARNING safety signs are located near specific hazards. General precautions are listed on CAUTION safety signs. CAUTION also calls attention to safety messages in this manual.

Replace Safety Signs

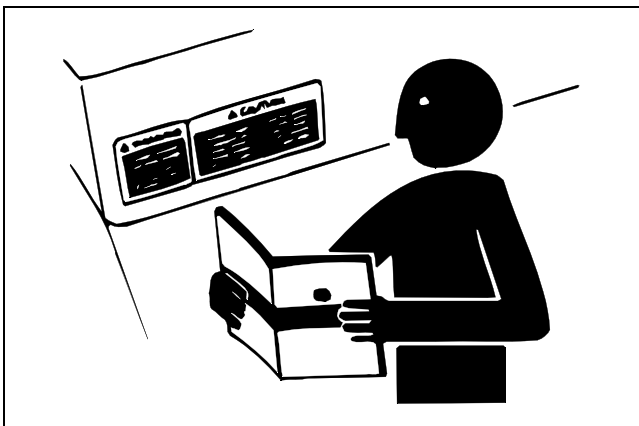

MIF

Replace missing or damaged safety signs. See the machine operator's manual for correct safety sign placement.

Handle Fluids Safely - Avoid Fires

Be Prepared For Emergencies

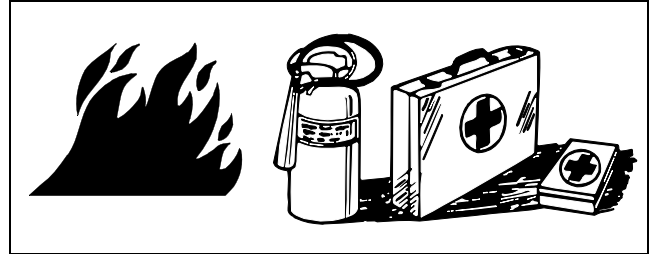

MIF

- When you work around fuel, do not smoke or work near heaters or other fire hazards.
- Store flammable fluids away from fire hazards. Do not incinerate or puncture pressurized containers.
- Make sure machine is clean of trash, grease, and debris.
- Do not store oily rags; they can ignite and burn spontaneously.
- Be prepared if a fire starts.
- Keep a first aid kit and fire extinguisher handy.
- Keep emergency numbers for doctors, ambulance service, hospital, and fire department near your telephone.

Wear Protective Clothing

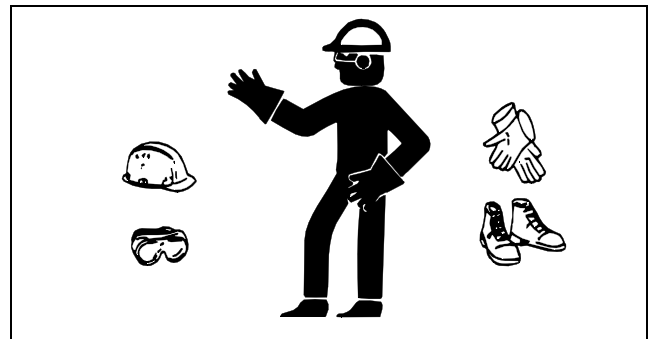

MIF

Wear close fitting clothing and safety equipment appropriate to the job.

Prolonged exposure to loud noise can cause impairment or loss of hearing. Wear a suitable hearing protective device such as earmuffs or earplugs to protect against objectionable or uncomfortable loud noises.

Operating equipment safely requires the full attention of the operator. Do not wear radio or music headphones while operating machine.

SAFETY

Use Care In Handling and Servicing Batteries

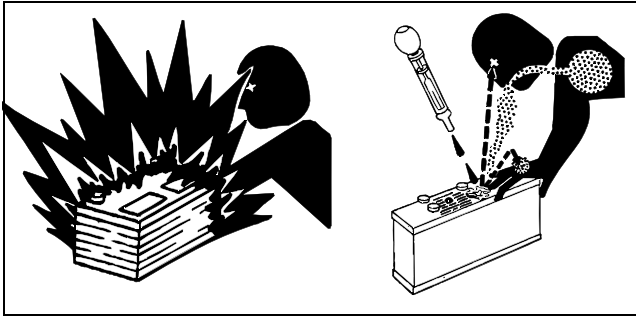

MIF

Prevent Battery Explosions

- Keep sparks, lighted matches, and open flame away from the top of battery. Battery gas can explode.
- Never check battery charge by placing a metal object across the posts. Use a volt-meter or hydrometer.
- Do not charge a frozen battery; it may explode. Warm battery to 16°C (60°F).

Prevent Acid Burns

- Sulfuric acid in battery electrolyte is poisonous. It is strong enough to burn skin, eat holes in clothing, and cause blindness if splashed into eyes.

Avoid acid burns by:

1. Filling batteries in a well-ventilated area.
2. Wearing eye protection and rubber gloves.
3. Avoiding breathing fumes when electrolyte is added.
4. Avoiding spilling or dripping electrolyte.
5. Use proper jump start procedure.

If you spill acid on yourself:

1. Flush your skin with water.
2. Apply baking soda or lime to help neutralize the acid.
3. Flush your eyes with water for 10 - 15 minutes.
4. Get medical attention immediately.

If acid is swallowed:

1. Drink large amounts of water or milk.
2. Then drink milk of magnesia, beaten eggs, or vegetable oil.
3. Get medical attention immediately.

Service Machines Safely

Tie long hair behind your head. Do not wear a necktie, scarf, loose clothing, or necklace when you work near machine tools or moving parts. If these items were to get caught, severe injury could result.

Remove rings and other jewelry to prevent electrical shorts and entanglement in moving parts.

Use Proper Tools

Use tools appropriate to the work. Makeshift tools and procedures can create safety hazards. Use power tools only to loosen threaded parts and fasteners. For loosening and tightening hardware, use the correct size tools. **DO NOT** use U.S. measurement tools on metric fasteners. Avoid bodily injury caused by slipping wrenches. Use only service parts meeting John Deere specifications.

Work In Clean Area

Before starting a job:

1. Clean work area and machine.
2. Make sure you have all necessary tools to do your job.
3. Have the right parts on hand.
4. Read all instructions thoroughly; do not attempt shortcuts.

Illuminate Work Area Safely

Illuminate your work area adequately but safely. Use a portable safety light for working inside or under the machine. Make sure the bulb is enclosed by a wire cage. The hot filament of an accidentally broken bulb can ignite spilled fuel or oil.

Using High Pressure Washers

Directing pressurized water at electronic/electrical components or connectors, bearings, hydraulic seals, fuel injection pumps or other sensitive parts and components may cause product malfunctions. Reduce pressure and spray at a 45 to 90 degree angle.

SAFETY

Park Machine Safely

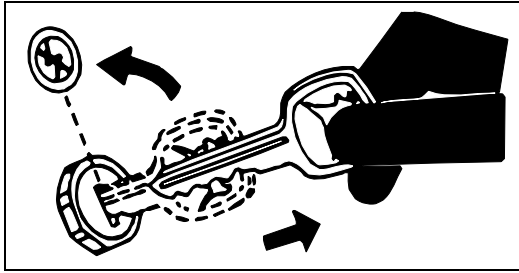

MIF

Before working on the machine:

1. Lower all equipment to the ground.
2. Lock the park brake.
3. Stop the engine and remove the key.
4. Disconnect the battery ground strap.
5. Hang a "DO NOT OPERATE" tag in operator station.

Work In Ventilated Area

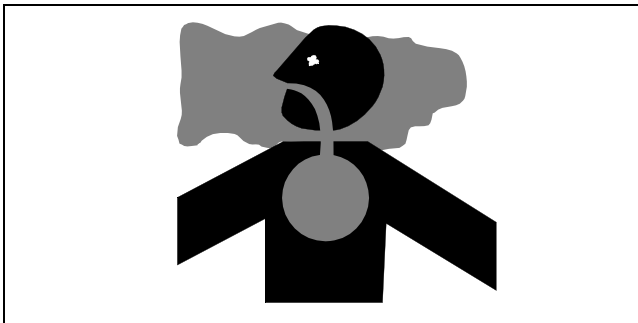

MIF

Engine exhaust fumes can cause sickness or death. If it is necessary to run an engine in an enclosed area, remove the exhaust fumes from the area with an exhaust pipe extension.

If you do not have an exhaust pipe extension, open the doors and get outside air into the area.

Warning: California Proposition 65 Warning

Gasoline engine exhaust from this product contains chemicals known to the State of California to cause cancer, birth defects, or other reproductive harm.

Diesel engine exhaust and some of its constituents are known to the State of California to cause cancer, birth defects, and other reproductive harm.

Avoid Injury From Rotating Blades and Shafts

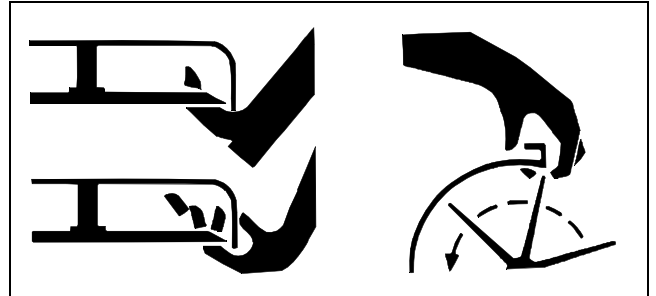

MIF

Keep hands and feet away while machine is running. Shut off power to service, lubricate or remove mower blades, augers or PTO shafts.

Dispose Of Waste Properly

Improperly disposing of waste can threaten the environment and ecology. Potentially harmful waste used with John Deere equipment include such items as oil, fuel, coolant, brake fluid, filters, and batteries. Use leakproof containers when draining fluids. Do not use food or beverage containers that may mislead someone into drinking from them. Do not pour waste onto the ground, down a drain, or into any water source. Inquire on the proper way to recycle or dispose of waste from your local environmental or recycling center, or from your John Deere dealer.

Handle Chemical Products Safely

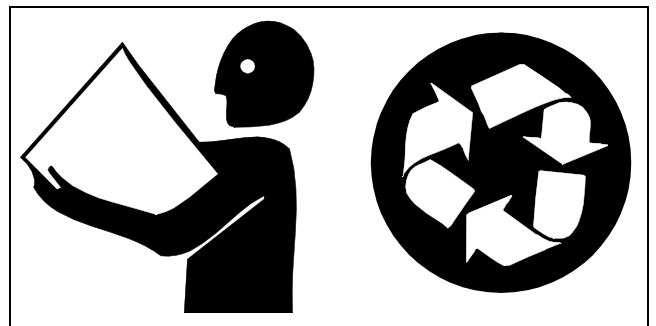

MIF

Direct exposure to hazardous chemicals can cause serious injury. Potentially hazardous chemicals used with John Deere equipment include such items as lubricants, coolants, paints, and adhesives.

A Material Safety Data Sheet (MSDS) provides specific details on chemical products: physical and health hazards, safety procedures, and emergency response techniques. Check the MSDS before you start any job using a hazardous chemical. That way you will know exactly what the risks are and how to do the job safely. Then follow procedures and recommended equipment.

Live With Safety



MIF

Before returning machine to customer, make sure machine is functioning properly, especially the safety systems. Install all guards and shields.

SPECIFICATIONS & INFORMATION TABLE OF CONTENTS

Table of Contents

General Specifications	7
Metric Fastener Torque Values	7
Metric Fastener Torque Values—Grade 7	8
Inch Fastener Torque Values	9
Gasket Sealant Application	10
O-Ring Seal Service Recommendations	11
Face Seal Fittings - Inch Stud Ends Torque.	11
Face Seal Fittings - Metric Stud Ends Torque	12
O-Ring Face Seal Fittings	13
O-Ring Boss Fittings	13
Fuels and Lubricants.....	14
Gasoline	14
Gasoline Storage.....	14
Engine Oil.....	15
Engine Break-in Oil.....	15
Alternative Lubricants.....	15
Synthetic Lubricants	15
Lubricant Storage	16
Mixing Of Lubricants.....	16
Chassis Grease.....	16
Mower Spindle Grease.....	16
Transaxle Oil - K46 and K58 Transaxles.....	16
Transaxle Oil - K58H Transaxle	16
Serial Number Locations	17
Product Identification Numbers	17

SPECIFICATIONS & INFORMATION TABLE OF CONTENTS



SPECIFICATIONS & INFORMATION GENERAL SPECIFICATIONS

General Specifications

Metric Fastener Torque Values

Property Class and Head Markings				
Property Class and Nut Markings				

TS1163

SIZE	Class 4.8		Class 8.8 or 9.8				Class 10.9				Class 12.9					
	Lubricated ^a		Dry ^a		Lubricated ^a		Dry ^a		Lubricated ^a		Dry ^a		Lubricated ^a		Dry ^a	
	N•m	lb-ft	N•m	lb-ft	N•m	lb-ft	N•m	lb-ft	N•m	lb-ft	N•m	lb-ft	N•m	lb-ft	N•m	lb-ft
M6	4.8	3.5	6	4.5	9	6.5	11	8.5	13	9.5	17	12	15	11.5	19	14.5
M8	12	8.5	15	11	22	16	28	20	32	24	40	30	37	28	47	35
M10	23	17	29	21	43	32	55	40	63	47	80	60	75	55	95	70
M12	40	29	50	37	75	55	95	70	110	80	140	105	130	95	165	120
M14	63	47	80	60	120	88	150	110	175	130	225	165	205	150	260	190
M16	100	73	125	92	190	140	240	175	275	200	350	225	320	240	400	300
M18	135	100	175	125	260	195	330	250	375	275	475	350	440	325	560	410
M20	190	140	240	180	375	275	475	350	530	400	675	500	625	460	800	580
M22	260	190	330	250	510	375	650	475	725	540	925	675	850	625	1075	800
M24	330	250	425	310	650	475	825	600	925	675	1150	850	1075	800	1350	1000
M27	490	360	625	450	950	700	1200	875	1350	1000	1700	1250	1600	1150	2000	1500
M30	675	490	850	625	1300	950	1650	1200	1850	1350	2300	1700	2150	1600	2700	2000
M33	900	675	1150	850	1750	1300	2200	1650	2500	1850	3150	2350	2900	2150	3700	2750
M36	1150	850	1450	1075	2250	1650	2850	2100	3200	2350	4050	3000	3750	2750	4750	3500

- DO NOT use these hand torque values if a different torque value or tightening procedure is given for a specific application. Torque values listed are for general use only and include a ± 10% variance factor. Check tightness of fasteners periodically. DO NOT use air powered wrenches.
- Shear bolts are designed to fail under predetermined loads. Always replace shear bolts with identical grade.
- Fasteners should be replaced with the same class. Make sure fastener threads are clean and that you properly start thread engagement. This will prevent them from failing when tightening.
- When bolt and nut combination fasteners are used,

torque values should be applied to the **NUT** instead of the bolt head.

- Tighten toothed or serrated-type lock nuts to the full torque value.

^a **“Lubricated” means coated with a lubricant such as engine oil, or fasteners with phosphate and oil coatings. “Dry” means plain or zinc plated (yellow dichromate—Specification JDS117) without any lubrication.**

Reference: JDS-200







SPECIFICATIONS & INFORMATION GENERAL SPECIFICATIONS

Metric Fastener Torque Values—Grade 7

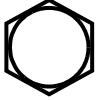
Size	Steel or Gray Iron Torque	Aluminum Torque
	N•m (lb-ft)	N•m (lb-ft)
M6	11 (8)	8 (6)
M8	24 (18)	19 (14)
M10	52 (38)	41 (30)
M12	88 (65)	70 (52)
M14	138 (102)	111 (82)
M16	224 (165)	179 (132)

SPECIFICATIONS & INFORMATION GENERAL SPECIFICATIONS

Inch Fastener Torque Values

SAE Grade and Head Markings	1 or 2 ^b No Marks 	5 5.1 5.2 	8 8.2 
SAE Grade and Nut Markings	2 No Marks 	5 	8  TS1162

TS1162

SIZE	Grade 1		Grade 2 ^b				Grade 5, 5.1 or 5.2				Grade 8 or 8.2					
	Lubricated ^a		Dry ^a		Lubricated ^a		Dry ^a		Lubricated ^a		Dry ^a		Lubricated ^a		Dry ^a	
	N•m	lb-ft	N•m	lb-ft	N•m	lb-ft	N•m	lb-ft	N•m	lb-ft	N•m	lb-ft	N•m	lb-ft	N•m	lb-ft
1/4	3.7	2.8	4.7	3.5	6	4.5	7.5	5.5	9.5	7	12	9	13.5	10	17	12.5
5/16	7.7	5.5	10	7	12	9	15	11	20	15	25	18	28	21	35	26
3/8	14	10	17	13	22	16	27	20	35	26	44	33	50	36	63	46
7/16	22	16	28	20	35	26	44	32	55	41	70	52	80	58	100	75
1/2	33	25	42	31	53	39	67	50	85	63	110	80	120	90	150	115
9/16	48	36	60	45	75	56	95	70	125	90	155	115	175	130	225	160
5/8	67	50	85	62	105	78	135	100	170	125	215	160	215	160	300	225
3/4	120	87	150	110	190	140	240	175	300	225	375	280	425	310	550	400
7/8	190	140	240	175	190	140	240	175	490	360	625	450	700	500	875	650
1	290	210	360	270	290	210	360	270	725	540	925	675	1050	750	1300	975
1-1/8	470	300	510	375	470	300	510	375	900	675	1150	850	1450	1075	1850	1350
1-1/4	570	425	725	530	570	425	725	530	1300	950	1650	1200	2050	1500	2600	1950
1-3/8	750	550	950	700	750	550	950	700	1700	1250	2150	1550	2700	2000	3400	2550
1-1/2	1000	725	1250	925	990	725	1250	930	2250	1650	2850	2100	3600	2650	4550	3350

- DO NOT use these hand torque values if a different torque value or tightening procedure is given for a specific application. Torque values listed are for general use only and include a ± 10% variance factor. Check tightness of fasteners periodically. DO NOT use air powered wrenches.

- Shear bolts are designed to fail under predetermined loads. Always replace shear bolts with identical grade.

- Fasteners should be replaced with the same class. Make sure fastener threads are clean and that you properly start thread engagement. This will prevent them from failing when tightening.

- When bolt and nut combination fasteners are used, torque values should be applied to the **NUT** instead of the bolt head.

- Tighten toothed or serrated-type lock nuts to the full torque value.

^a “**Lubricated**” means coated with a lubricant such as engine oil, or fasteners with phosphate and oil coatings. “**Dry**” means plain or zinc plated (yellow dichromate—Specification JDS117) without any lubrication.

^b “**Grade 2**” applies for hex cap screws (not hex bolts) up to 152 mm (6 in.) long “**Grade 1**” applies for hex cap screws over 152 mm (6 in.) long, and for all other types of bolts and screws of any length.

Reference: JDS-G200

Gasket Sealant Application

Cleaning:

Clean both surfaces that will be joined using 100% isopropyl alcohol. Wipe excess off with a clean cloth. Cleaner/degreaser can be substituted for isopropyl alcohol.

How to Dispense/Apply/Assemble Gasket Sealants:

Dispense approximately 1 to 2 ounces of flexible form-in-place gasket on a clean sheet or table top. Avoid using excess amounts that may be exposed for long periods of time. This will help prevent contamination from surrounding atmosphere such as dust with metal content.

Using an ink roller or similar device, apply to one surface of the joint by loading the roller from a plastic sheet and transferring the material in a thin film to the joint. The application should be the thinnest film possible, but providing complete coverage. This can be judged by the appearance of the joint once it is put together. Excessive amounts will cause incorrect bearing end play, extend cure time, and will cause runoff of the material. A small bead or buildup at the joint is permissible and indicates good dispersion through the joint. Excess can be wiped from the joint. Joining should take place within three minutes after sealant application.

Apply proper cap screw torque and sequence as applicable. Allow a minimum of 30 minutes before air test or adding oil for test stand usage.

Disassembly:

Cured material can be removed with a wire brush or scraper. Chemical cleaners are available for customer use, should they be deemed necessary.

SPECIFICATIONS & INFORMATION O-RING SEAL SERVICE

O-Ring Seal Service Recommendations

Face Seal Fittings - Inch Stud Ends Torque

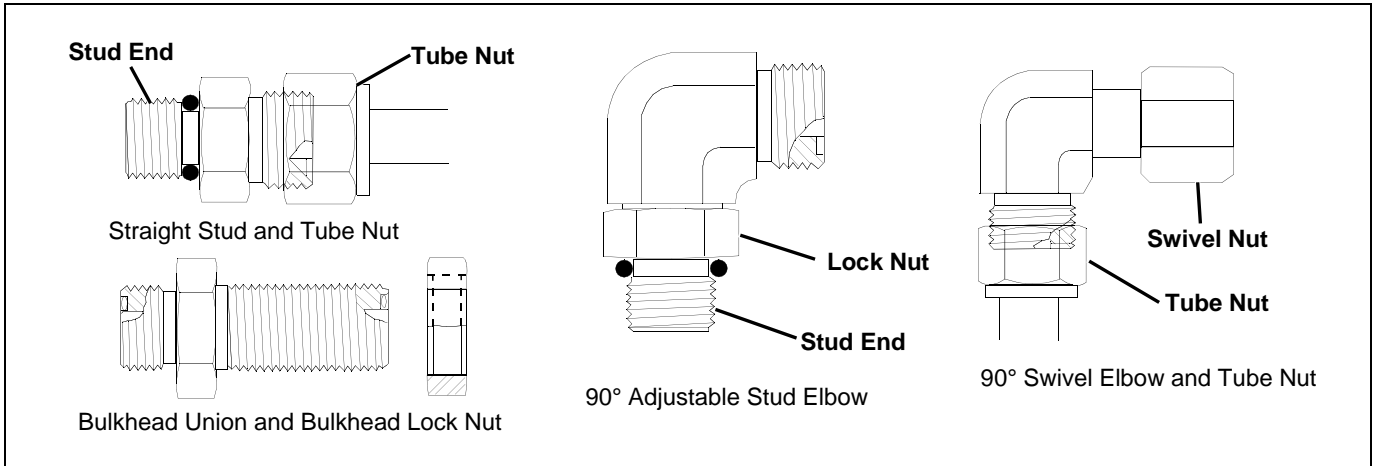

MIF

Nominal Tube OD/Hose ID				Face Seal Tube/Hose End					O-Ring Stud Ends		
Metric Tube OD	Inch Tube OD			Thread Size	Tube Nut/ Swivel Nut Torque		Bulkhead Lock Nut Torque		Thread Size	Straight Fitting or Lock Nut Torque	
	Dash Size	in.	mm		in.	N•m	lb-ft	N•m		lb-ft	in.
	-3	0.188	4.76						3/8-24	8	6
6	-4	0.250	6.35	9/16-18	16	12	12	9	7/16-20	12	9
8	-5	0.312	7.94						1/2-20	16	12
10	-6	0.375	9.52	11/16-16	24	18	24	18	9/16-18	24	18
12	-8	0.500	12.70	13/16-16	50	37	46	34	3/4-16	46	34
16	-10	0.625	15.88	1-14	69	51	62	46	7/8-14	62	46
	-12	0.750	19.05	1-3/16-12	102	75	102	75	1-1/16-12	102	75
22	-14	0.875	22.22	1-3/16-12	102	75	102	75	1-3/16-12	122	90
25	-16	1.000	25.40	1-7/16-12	142	105	142	105	1-5/16-12	142	105
32	-20	1.25	31.75	1-11/16-12	190	140	190	140	1-5/8-12	190	140
38	-24	1.50	38.10	2-12	217	160	217	160	1-7/8-12	217	160

Note: Torque tolerance is +15%, -20%

SPECIFICATIONS & INFORMATION O-RING SEAL SERVICE

Face Seal Fittings - Metric Stud Ends Torque

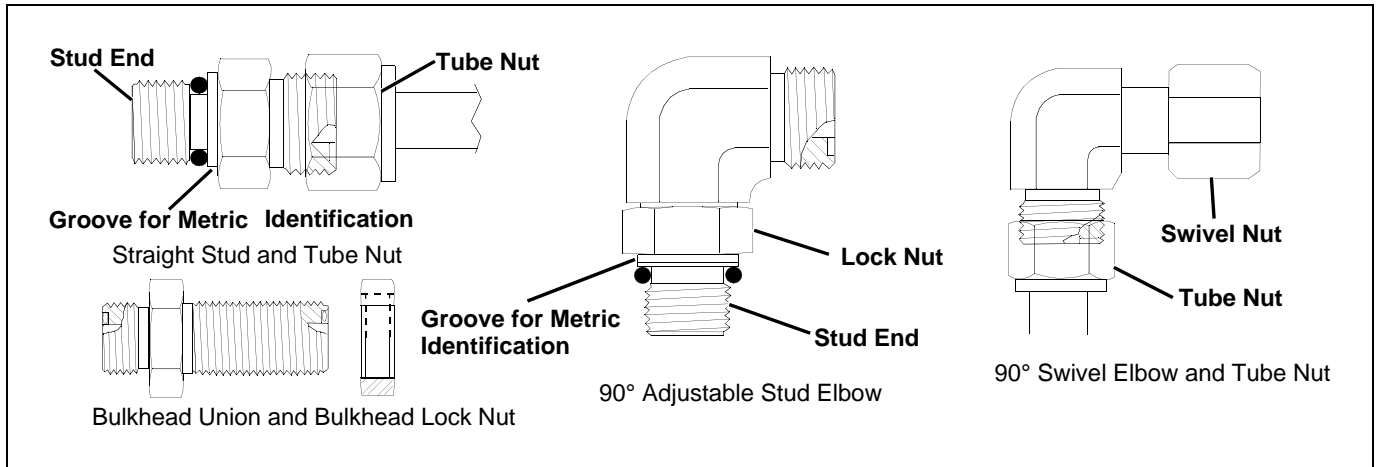

MIF

Nominal Tube OD/Hose ID				Face Seal Tube/Hose End						O-Ring Stud Ends, Straight Fitting or Lock Nut					
Metric Tube OD	Inch Tube OD			Thread Size	Hex Size	Tube Nut/ Swivel Nut Torque		Bulkhead Lock Nut Torque		Thread Size	Hex Size	Steel or Gray Iron Torque		Aluminum Torque	
	mm	Dash Size	in.			mm	in.	mm	N•m			lb-ft	N•m	lb-ft	mm
6	-4	0.250	6.35	9/16-18	17	16	12	12	9	M12X1.5	17	21	15.5	9	6.6
8	-5	0.312	7.94												
										M14X1.5	19	33	24	15	11
10	-6	0.375	9.52	11/16-16	22	24	18	24	18	M16X1.5	22	41	30	18	13
12	-8	0.500	12.70	13/16-16	24	50	37	46	34	M18X1.5	24	50	37	21	15
16	-10	0.625	15.88	1-14	30	69	51	62	46	M22X1.5	27	69	51	28	21
	-12	0.750	19.05	1-3/16-12	36	102	75	102	75	M27X2	32	102	75	46	34
22	-14	0.875	22.22	1-3/16-12	36	102	75	102	75	M30X2	36				
25	-16	1.000	25.40	1-7/16-12	41	142	105	142	105	M33X2	41	158	116	71	52
28										M38X2	46	176	130	79	58
32	-20	1.25	31.75	1-11/16-12	50	190	140	190	140	M42X2	50	190	140	85	63
38	-24	1.50	38.10	2-12	60	217	160	217	160	M48X2	55	217	160	98	72

Note: Torque tolerance is +15%, -20%

SPECIFICATIONS & INFORMATION O-RING SEAL SERVICE

O-Ring Face Seal Fittings

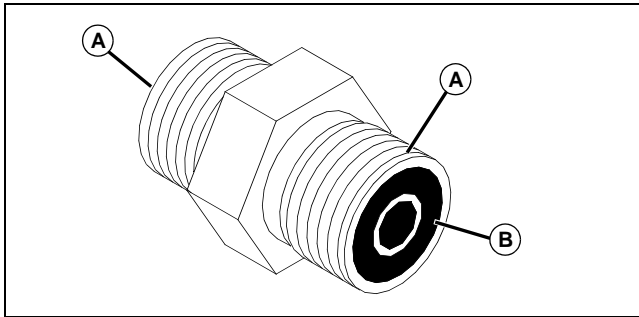

MIF

1. Inspect the fitting sealing surfaces (A). They must be free of dirt or defects.
2. Inspect the O-ring (B). It must be free of damage or defects.
3. Lubricate O-rings and install into groove using petroleum jelly to hold in place.
4. Push O-ring into the groove with plenty of petroleum jelly so O-ring is not displaced during assembly.
5. Index angle fittings and tighten by hand-pressing joint together to ensure O-ring remains in place.

Important: Avoid Damage! DO NOT allow hoses to twist when tightening fittings. Use two wrenches to tighten hose connections; one to hold the hose, and the other to tighten the swivel fitting.

6. Tighten fitting or nut to torque value shown on the chart per dash size stamped on the fitting.

O-Ring Boss Fittings

1. Inspect boss O-ring boss seat. It must be free of dirt and defects. If repeated leaks occur, inspect for defects with a magnifying glass. Some raised defects can be removed with a slip stone.

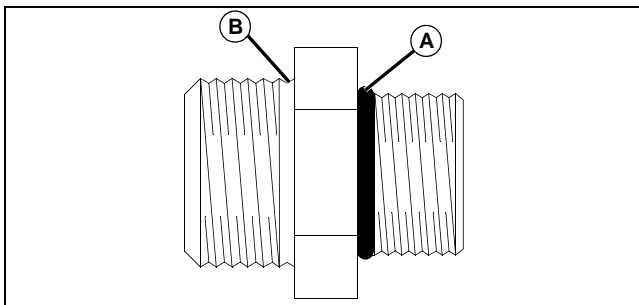

MIF

2. Put hydraulic oil or petroleum jelly on the O-ring (A). Place electrical tape over the threads to protect O-ring from nicks. Slide O-ring over the tape and into the groove (B) of fitting. Remove tape.

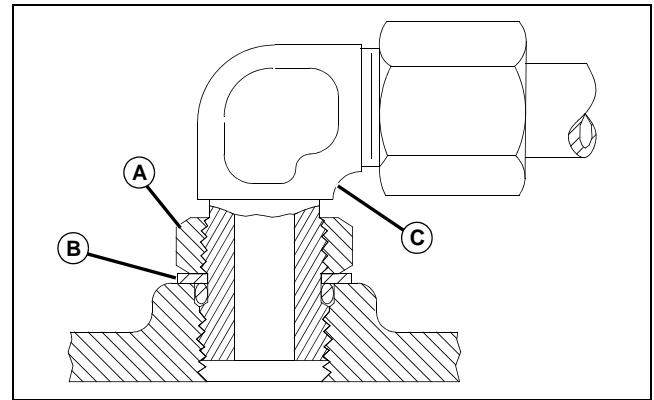

MIF

3. For angle fittings, loosen special nut (A) and push special washer (B) against threads so O-ring can be installed into the groove of fitting.
4. Turn fitting into the boss by hand until special washer or washer face (straight fitting) contacts boss face and O-ring is squeezed into its seat.
5. To position angle fittings (C), turn the fitting counter-clockwise a maximum of one turn.
6. Tighten straight fittings to torque value shown on chart. For angle fittings, tighten the special nut to value shown in the chart while holding body of fitting with a wrench.

Thread Size	Torque ^a		Number of Flats ^b
	N•m	lb-ft	
3/8-24 UNF	8	6	2
7/16-20 UNF	12	9	2
1/2-20 UNF	16	12	2
9/16-18 UNF	24	18	2
3/4-16 UNF	46	34	2
7/8-14 UNF	62	46	1-1/2
1-1/16-12 UN	102	75	1
1-3/16-12 UN	122	90	1
1-5/16-12 UN	142	105	3/4
1-5/8-12 UN	190	140	3/4
1-7/8-12 UN	217	160	1/2

^aTorque tolerance is ± 10 percent.

^bTo be used if a torque wrench cannot be used. After tightening fitting by hand, put a mark on nut or boss; then tighten special nut or straight fitting the number of flats shown.

Fuels and Lubricants

Gasoline



Caution: Avoid Injury! Gasoline is HIGHLY FLAMMABLE, handle it with care. **DO NOT** refuel machine while:

- indoors, always fill gas tank outdoors
- machine is near an open flame or sparks
- engine is running, **STOP** engine
- engine is hot, allow it to cool sufficiently first
- smoking

Help prevent fires:

- fill gas tank to bottom of filler neck only
- be sure fill cap is tight after fueling
- clean up any gas spills **IMMEDIATELY**
- keep machine clean and in good repair-free of excess grease, oil, debris, and faulty or damaged parts
- any storage of machines with gas left in tank should be in an area that is well ventilated to prevent possible igniting of fumes by an open flame or spark, this includes any appliance with a pilot light

To prevent fire or explosion caused by **STATIC ELECTRIC DISCHARGE** during fueling:

ONLY use a clean, approved **POLYETHYLENE PLASTIC** fuel container and funnel **WITHOUT** any metal screen or filter

To avoid engine damage:

- DO NOT mix oil with gasoline
- ONLY** use clean, fresh unleaded gasoline with an octane rating (anti-knock index) of 87 or higher
- fill gas tank at the end of each day's operation to help prevent condensation from forming inside a partially filled tank
- keep up with specified service intervals

Use of alternative oxygenated, gasohol blended, unleaded gasoline is acceptable as long as:

- the ethyl or grain alcohol blends DO NOT exceed 10% by volume or

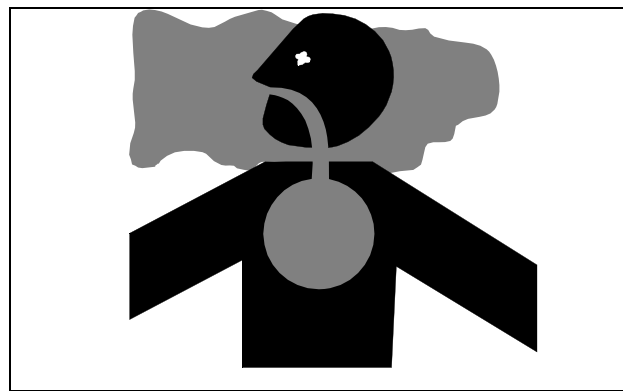

MIF

- methyl tertiary butyl ether (MTBE) blends DO NOT exceed 15% by volume

Important: Avoid Damage! DO NOT use METHANOL gasolines because METHANOL is harmful to the environment and to your health.



Caution: Avoid Injury! California Proposition 65 Warning: Gasoline engine exhaust from this product contains chemicals known to the State of California to cause cancer, birth defects, or other reproductive harm.

Gasoline Storage

Important: Avoid Damage! Keep all dirt, scale, water or other foreign material out of gasoline.

Keep gasoline stored in a safe, protected area. Storage of gasoline in a clean, properly marked ("UNLEADED GASOLINE") POLYETHYLENE PLASTIC container WITHOUT any metal screen or filter is recommended. DO NOT use de-icers to attempt to remove water from gasoline or depend on fuel filters to remove water from gasoline. Use a water separator installed in the storage tank outlet. BE SURE to properly discard unstable or contaminated gasoline. When storing machine or gasoline, it is recommended that you add **John Deere Gasoline Conditioner and Stabilizer (TY15977)** or an equivalent to the gasoline. BE SURE to follow directions on container and to properly discard empty container.

SPECIFICATIONS & INFORMATION FUELS AND LUBRICANTS

Engine Oil

Use the appropriate oil viscosity based on the expected air temperature range during the period between recommended oil changes. Operating outside of these recommended oil air temperature ranges may cause premature engine failure.

The following John Deere oils are PREFERRED:

- **TURF-GARD™ - SAE 10W-30;**
- **PLUS-4™ - SAE 10W-30;**

The following John Deere oils are **also recommended**, based on their specified temperature range:

- **TORQ-GARD SUPREME™ - SAE 30;**

Other oils may be used if above John Deere oils are not available, provided they meet one of the following specifications:

- SAE 30 - API Service Classification SJ or higher;
- SAE 10W-30 - API Service Classification SJ or higher;

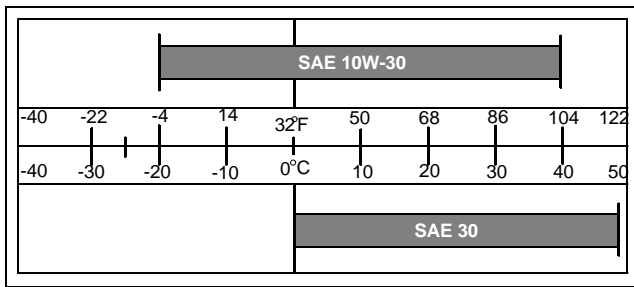

Engine Break-in Oil

Important: Avoid Damage! ONLY use a quality break-in oil in rebuilt or remanufactured engines for the first 5 hours (maximum) of operation. DO NOT use oils with heavier viscosity weights than SAE 5W-30 or oils meeting specifications API SG or SH, these oils will not allow rebuilt or remanufactured engines to break-in properly.

The following John Deere oil is PREFERRED:

- **BREAK-IN ENGINE OIL.**

John Deere BREAK-IN ENGINE OIL is formulated with special additives for aluminum and cast iron type engines to allow the power cylinder components (pistons, rings, and liners as well) to “wear-in” while protecting other engine components, valve train and gears, from abnormal wear. Engine rebuild instructions should be followed closely to determine if special requirements are necessary.

John Deere BREAK-IN ENGINE OIL is also recommended for non-John Deere engines, both aluminum and cast iron types.

The following John Deere oil is **also recommended as a break-in engine oil**:

- **TORQ-GARD SUPREME®—SAE 5W-30.**

If the above recommended John Deere oils are not available, use a break-in engine oil meeting the following specification during the first 5 hours (maximum) of operation:

- SAE 5W-30—API Service Classification SE or higher.

Important: Avoid Damage! After the break-in period, use the John Deere oil that is recommended for this engine.

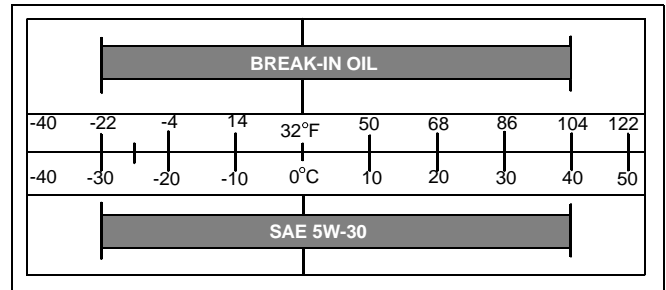

Alternative Lubricants

Conditions in certain geographical areas outside the United States and Canada may require different lubricant recommendations than the ones printed in this technical manual or the operator's manual. Consult with your John Deere Dealer, or Sales Branch, to obtain the alternative lubricant recommendations.

Important: Avoid Damage! Use of alternative lubricants could cause reduced life of the component.

If alternative lubricants are to be used, it is recommended that the factory fill be thoroughly removed before switching to any alternative lubricant.

Synthetic Lubricants

Synthetic lubricants may be used in John Deere equipment if they meet the applicable performance requirements (industry classification and/or military specification) as shown in this manual.

The recommended air temperature limits and service or lubricant change intervals should be maintained as shown in the operator's manual.

Avoid mixing different brands, grades, or types of oil. Oil manufacturers blend additives in their oils to meet certain specifications and performance requirements. Mixing different oils can interfere with the proper functioning of

SPECIFICATIONS & INFORMATION FUELS AND LUBRICANTS

these additives and degrade lubricant performance.

Lubricant Storage

All machines operate at top efficiency only when clean lubricants are used. Use clean storage containers to handle all lubricants. Store them in an area protected from dust, moisture, and other contamination. Store drums on their sides. Make sure all containers are properly marked as to their contents. Dispose of all old, used containers and their contents properly.

Mixing Of Lubricants

In general, avoid mixing different brands or types of lubricants. Manufacturers blend additives in their lubricants to meet certain specifications and performance requirements. Mixing different lubricants can interfere with the proper functioning of these additives and lubricant properties which will downgrade their intended specified performance.

Chassis Grease

Use the following grease based on the air temperature range. Operating outside of the recommended grease air temperature range may cause premature failures.

The following John Deere grease is PREFERRED:

- **NON-CLAY HIGH-TEMPERATURE EP GREASE®—JDM J13E4, NLGI Grade 2.**
- Multi-Purpose SD Polyurea Grease
- Multi-Purpose HD Lithium Complex Grease

Other greases may be used if above preferred John Deere grease is not available, provided they meet the following specification:

- John Deere Standard JDM J13E4, NLGI Grade 2.

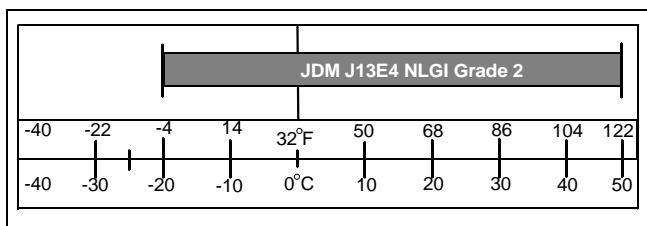

Mower Spindle Grease

This premium, multi-purpose grease is specially formulated as a high-temperature, extreme-pressure grease, especially effective in rolling contact applications.

The following water resistant grease is **preferred**:

- Multi-Purpose SD Polyurea Grease - TY6341.

The following multi-purpose grease may also be used:

- Multi-Purpose HD Lithium Complex Grease - TY24416.

Other greases may be used if they meet or exceed the following specification:

- John Deere Standard JDM J13E4, NLGI Grade 2.

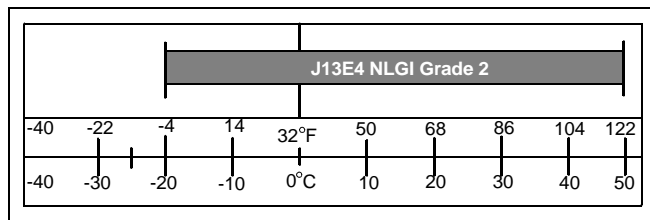

Transaxle Oil - K46 and K58 Transaxles

These machines are equipped with an internal wet disc brake transmission (Hydrostatic transmission).

Important: Avoid Damage! Use ONLY the following oils for service. DO NOT use automatic transmission fluid.

Note: The K46 and K58 transaxles (without power steering or attachment lift cylinders) are filled with 10W30 engine oil at the factory.

For the transaxles used in extreme or high-hour applications, J20C Hygard Hydraulic oil or 5W-50 Synthetic Engine Oil is approved as an optional fill. Use only after a complete drain of the factory oil.

Transaxle Oil - K58H Transaxle

These machines are equipped with an internal wet disc brake transmission.

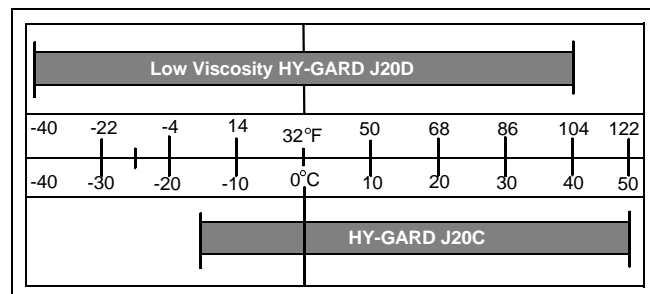

SPECIFICATIONS & INFORMATION SERIAL NUMBER LOCATIONS

Use the appropriate oil viscosity based on these air temperature ranges. Operating outside of these recommended oil air temperature ranges may cause premature hydrostatic transmission or hydraulic system failures.

Important: Avoid Damage! Mixing of LOW VISCOSITY HY - GARD™ and HY - GARD™ oils is permitted. DO NOT mix any other oils in this transmission. DO NOT use engine oil or “Type F” (Red) Automatic Transmission Fluid in this transmission.

John Deere J20D Low Viscosity transmission and hydraulic oil is recommended. John Deere John Deere J20C HY-GARD™ transmission and hydraulic oil may be used, if within the specified temperature range.

Other oils may be used if above recommended John Deere oils are not available, provided they meet one of the following specifications:

- John Deere Standard JDM J20D;
- John Deere Standard JDM J20C.

Serial Number Locations

Product Identification Numbers

When ordering parts or submitting a warranty claim, it is IMPORTANT that the machine product identification number (PIN) and component serial numbers are included. The location of the PIN and component serial numbers are shown.

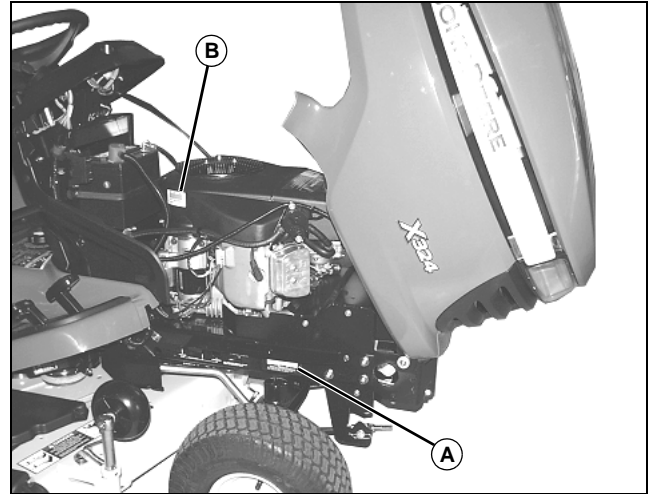

MX36205

The machine identification (A) is located on right side of frame.

The engine identification number (B) is located on the engine housing.

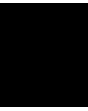

ENGINE - KAWASAKI (FH491V) TABLE OF CONTENTS

Table of Contents	
Specifications	21
General Specifications	21
Test and Adjustment Specifications	21
Repair Specifications.....	21
Torque Specifications.....	23
Tools.....	24
Other Materials.....	24
Component Location	25
Carburetor Components.....	25
Engine Block	26
Engine Valves and Governor	28
Engine Shields	30
Theory of Operation	31
Engine Oil Flow Chart	31
Lubrication System Operation	31
Carburetor Operation	32
Diagnostics	35
Engine Troubleshooting Guide.....	35
Starting Motor Troubleshooting Guide	37
Carburetor Troubleshooting Guide.....	37
Carburetor Air/Fuel Diagnosis	38
Carburetor Diagnostic Inspection	40
General Information	41
Cleaning Carburetors	41
Cleaning Methods	42
Fuel	42
Tests and Adjustments	43
Throttle Cable Check and Adjustment.....	43
Choke Cable Adjustment	44
Governor Adjustment	45
Slow Idle Speed Adjustment	46
Fast Idle Speed Adjustment	46
Valve Clearance, Check and Adjustment.....	47
Cylinder Leak-Down Test.....	48
Cylinder Compression Pressure Test.....	49
Crankcase Vacuum Test.....	49
Engine Oil Pressure Test	50
Fuel Pump Test.....	51
Spark Test.....	51
Spark Plug Gap	52
Ignition Coil Air Gap Adjustment	52
Repair	53
Engine Removal and Installation	53
Air Cleaner Assembly	55
Carburetor Removal, Disassembly, and Installation.....	55
Fuel Pump Removal and Installation	57
Blower Housing Removal and Installation ...	57
Flywheel Removal and Installation	58
Muffler Removal and Installation	58
Breather Inspection.....	59
Rocker Arm Removal and Installation	60
Cylinder Head Removal and Installation.....	61
Cylinder Head Inspection.....	61
Recondition Valve Seats.....	63
Lap Valves.....	64
Crankcase Cover Removal and Installation.	64
Piston and Connecting Rod	65
Camshaft and Tappets	69
Crankshaft and Main Bearings	70
Crankshaft Oil Seals	72
Deglaze Cylinder Bore.....	72
Resize Cylinder Bore	72
Oil Pump Disassembly and Assembly	73
Governor Removal, Inspection, and Replacement.....	75
Governor Shaft Inspection and Replacement.....	75
Stator Removal and Installation.....	76
Ignition Coil Removal and Installation.....	76
Starting Motor	76
No-Load Amperage Draw and RPM Test....	79
Starting Solenoid Test	79

ENGINE - KAWASAKI (FH491V) TABLE OF CONTENTS



ENGINE - KAWASAKI (FH491V) SPECIFICATIONS

Specifications

General Specifications

General Specifications:

Engine Use	X300 and X304
Make	Kawasaki V-Twin
Model Number	FH491V
Bore	68 mm (2.68 in.)
Stroke	65 mm (2.56 in.)
Displacement	472cm ³ (28.8 cu in.)
Cylinders	2 (V-Twin)
Stroke Cycle	4
Valves	Overhead
Lubrication	Fully Pressurized
Oil Capacity w/ Oil Filter	1.8 L (1.9 qt)
Oil Filter	Single Element, Full Flow, Spin-On
Cooling System	Air
Muffler	Horizontal Discharge Below Frame
Spark Plug Gap	0.76 mm (0.030 in.)
Spark Plug Torque	22 N•m (195 lb-in.)

Test and Adjustment Specifications

Test and Adjustment Specifications:

Governed Low Idle	1850 ± 100 rpm
Fast Idle	3350 ± 100 rpm
Low Speed Carb Idle Screw	1450 ± 100 rpm
Ignition Coil Air Gap	0.25 - 0.40 mm (0.010 - 0.016 in.)
Oil Pressure @ 3000 rpm	240 - 310 kPa (35 - 45 psi)
Crankcase Vacuum	1.3 - 25.4 cm (0.5 - 10.0 in.)
Cylinder Compression (Minimum)	390 kPa (57 psi)
Valve Clearance (Intake and Exhaust) (Cold)	0.075 - 0.125 mm (0.003 - 0.005 in.)
Fuel Pump Pressure (Slow Idle)	2.45 kPa (0.36 psi)
Minimum Fuel Flow	65 mL (2.2 oz)/15 seconds

Repair Specifications

Cylinder Head:

Cylinder Head Distortion (Maximum)	0.03 mm (0.001 in.)
Valve Guides ID	6.00 - 6.01 mm (0.0236 - 0.237 in.)
Valve Guides ID (Maximum)	6.08 mm (0.239 in.)
Valve Seat Width	0.6 - 0.9 mm (0.024 - 0.035 in.)
Valve Spring Free Length	31.0 mm (1.22 in.)

Intake and Exhaust Valves:

Valve Clearance (Intake and Exhaust) (Cold)	0.075 - 0.125 mm (0.003 - 0.005 in.)
Valve Stem OD (Intake) (Minimum)	5.93 mm (0.233 in.)

ENGINE - KAWASAKI (FH491V) SPECIFICATIONS

Valve Stem OD (Exhaust) (Minimum)	5.93 mm (0.233 in.)
Valve Stem Bend (Maximum).....	0.03 mm (0.001 in.)
Valve Guide ID (Standard)	6.00 - 6.012 mm (0.236 - 0.237 in.)
Valve Guide ID (Maximum).....	6.08 mm (0.239 in.)
Valve Seating Surface (Standard).....	0.60 - 0.90 mm (0.024 - 0.035 in.)
Valve Seat and Face Angle	45°
Valve Margin (Minimum)	0.35 mm (0.014 in.)
Valve Seat Narrowing Angle	32°

Piston Assembly:

Piston Ring Side Clearance (Top Ring)	0.15 mm (0.006 in.)
Piston Ring Side Clearance (Second Ring)	0.12 mm (0.005 in.)
Piston Ring Side Clearance (Oil Ring)Not Measured
Piston Ring Thickness (Top and Second)	1.40 mm (0.055 in.)
Piston Ring End Gap Maximum (Top Ring)	0.70 mm (0.028 in.)
Piston Ring End Gap Maximum (Second Ring).....	0.78 mm (0.031 in.)
Piston Ring End Gap Maximum (Oil Ring).....	1.05 mm (0.041 in.)
Piston Pin OD (Minimum)	15.96 mm (0.628 in.)
Piston Pin Bore OD (Maximum)	16.08 mm (0.633 in.)
Piston OD (Standard Minimum).....	67.79 mm (2.669 in.)
Piston OD (Oversize 0.50 mm (0.020 in.)	68.29 mm (2.689 in.)
Piston-to-Cylinder Bore Clearance.....	0.015 - 0.15 mm (0.001 - 0.006 in.)
Cylinder Bore ID (Standard).....	67.98 - 68.00 mm (2.676 - 2.677 in.)
Cylinder Bore ID (Wear Limit)	68.10 mm (2.681 in.)
Cylinder Bore ID (Oversize 0.50 mm (0.020 in.))	68.48 - 68.50 mm (2.696 - 2.697 in.)
Cylinder Bore ID (Oversize 0.50 mm (0.020 in.) Wear Limit).....	68.60 mm (2.701 in.)

Connecting Rod:

Crankshaft Bearing ID (Maximum)	35.06 mm (1.380 in.)
Piston Pin Bearing ID (Maximum).....	16.05 mm (0.632 in.)

Crankshaft:

Crankpin Width (Maximum).....	39.50 mm (1.380 in.)
Crankpin OD (Minimum)	34.94 mm (1.376 in.)
Journal Diameter (PTO Side) (Minimum)	34.90 mm (1.374 in.)
Journal Diameter (Flywheel Side) (Minimum)	34.93 mm (1.375 in.)
Crankcase Cover PTO Shaft ID (Maximum)	35.15 mm (1.384 in.)
Crankcase Crankshaft Journal Bearing ID (Maximum).....	35.15 mm (1.384 in.)

Camshaft:

Lobe Height (Intake and Exhaust) (Minimum)	29.13 mm (1.147 in.)
Journal Diameter (PTO and Flywheel) (Minimum).....	15.99 mm (0.629 in.)
Bearing ID (Crankcase and Cover) (Maximum)	16.14 mm (0.635 in.)

Oil Pump:

Rotor Shaft OD (Minimum)	10.92 mm (0.430 in.)
Rotor Shaft Bearing ID (Maximum).....	11.07 mm (0.436 in.)
Outer Rotor OD (Minimum)	40.47 mm (1.593 in.)
Outer Rotor Bearing ID (Maximum)	40.80 mm (1.606 in.)

ENGINE - KAWASAKI (FH491V) SPECIFICATIONS

Outer Rotor Thickness (Minimum)	9.83 mm (0.387 in.)
Inner and Outer Rotor Clearance (Maximum)	0.2 mm (0.008 in.)
Pump Housing Depth (Maximum)	10.23 mm (0.403 in.)
Spring Free Length (Minimum)	19.5 mm (0.768 in.)
Oil Pressure Sensor Continuity (On)	98 kPa (14.2 psi)
Oil Filter Bypass Valve Opening Pressure	78.5 - 117.5 kPa (11.4 - 17.1 psi)

Starting Motor:

Maximum Amperage (No Load)	50 amps @ 6000 rpm
Brush Length (Minimum)	6.4 mm (0.25 in.)

Torque Specifications

Torque Specifications:

Breather Cover Cap Screws	6.9 N•m (61 lb-in.)
Carburetor Mounting Stud Nut	6.9 N•m (61 lb-in.)
Connecting Rod Cap Screw	5.9 N•m (52 lb-in.)
Cooling Shroud Mounting Cap Screws	5.9 N•m (52 lb-in.)
Cylinder Head Cap Screws (Initial Torque)	13 N•m (115 lb-in.)
Cylinder Head Cap Screws (Final Torque)	25 N•m (221 lb-in.)
Crankcase Cover Mounting Cap Screws	25 N•m (221 lb-in.)
Engine Mounting Cap Screws	34 N•m (25 lb-ft)
Exhaust Pipe Nuts	22 N•m (16 lb-ft)
Fan Housing Cap Screws	5.9 N•m (52 lb-in.)
Flywheel Cap Screw	56 N•m (41 lb-ft)
Fuel Pump Mounting Cap Screws	5.9 N•m (52 lb-in.)
Fuel Solenoid to Carburetor	6.9 N•m (61 lb-in.)
Governor Arm Clamp Nut	7.8 N•m (69 lb-in.)
Governor Shaft Plate Screws	2 N•m (17 lb-in.)
Ignition Coil Cap Screws	7.8 N•m (69 lb-in.)
Intake Manifold Cap Screws (Initial Torque)	3 N•m (27 lb-in.)
Intake Manifold Cap Screws (Final Torque)	6.9 N•m (61 lb-in.)
Oil Plug	6.9 N•m (61 lb-in.)
Oil Pump Cover Cap Screws	5.9 N•m (52 lb-in.)
Rocker Arm Stud Bolts	28 N•m (247 lb-in.)
Rocker Cover Cap Screws	6.9 N•m (61 lb-in.)
Spark Plug Torque	22 N•m (16 lb-ft)
Starting Motor Mounting Cap Screws	15 N•m (133 lb-in.)
Stator Coil Cap Screws	3.9 N•m (35 lb-in.)

ENGINE - KAWASAKI (FH491V) SPECIFICATIONS

Tools

Note: Order tools according to information given in the U.S. SERVICE-GARD™ Catalog or in the European Microfiche Tool Catalog (MTC).

Special or Required Tools

Tool Name	Tool No.	Tool Use
Hand-Held Digital Tachometer	JT05719	Used to check idle speed and starter performance.
Digital Pulse Tachometer	JT07270	Used to check idle speed and starter performance.
Compression Gauge	JDM59	Used to check engine compression.
U-Tube Manometer Test Kit	JT05698	Used to check engine crankcase vacuum.
Vacuum Gauge	JT03503	Used to check engine crankcase vacuum.
Drill Bit	6.4 mm (0.25 in.)	Throttle adjustment.
Lapping Tool	- - -	Valve lapping
Dial Indicator	- - -	Automatic compression relief test, valve inspection, crankshaft end play.
Spark Plug Ground	JDM74A5	Used to prevent accidental engine starting during tests.
Reaming Tool (7.05 mm)	D20020W1	Clean or size valve guide.
Reaming Tool (7.25 mm)	D20020W1	Clean or size oversize valve guide.
90° Elbow Fitting Hose Assembly	JT03338 JT03017	Used to connect pressure gauge to engine when performing engine oil pressure test.
Pressure Gauge Assembly	JT03344	Used to read engine oil pressure when performing engine oil pressure test.
Pressure Gauge	JDG356	Used to check fuel pump performance.

Special or Required Tools

Tool Name	Tool No.	Tool Use
Spark Tester	D-05351ST	Used to check overall condition of ignition system.
Valve Spring Compressor	JDM70	Used to remove and install valve springs.
Current Gun	JT05712	Used to check starter performance.

Other Materials

Other Material

Part No.	Part Name	Part Use
TY24416	Multipurpose Lithium Grease	Apply to engine crankshaft
	SCOTCH-BRITE® Abrasive Sheets/Pads	Clean cylinder head
	Valve Guide Cleaner	Clean valve guides
	Prussian Blue Compound	Check valve seat contact
TY24416	Lithium Base Grease	Pack oil seals
	Zinc Oxide/Wood Alcohol	Check block for cracks
	Mineral Spirits	Clean armature
	Valve Lap Compound	Lap valves
PM37418 LOCTITE 242	Thread Lock and Sealer (Medium Strength)	Apply to threads of throttle and choke plate screws
PM37565 LOCTITE 587 Canada PM38616	RTV Silicone Form-in-Place Gasket	Rocker arm cover mating surfaces
PM37397 LOCTITE 592	Thread Sealant (General Purpose) with TEFLON	Apply to threads of pipe plugs

LOCTITE is a registered trademark of the Loctite Corp.

SCOTCH-BRITE is a registered trademark of the 3M Co.

TEFLON® is a registered trademark of DuPont.

ENGINE - KAWASAKI (FH491V) COMPONENT LOCATION

Component Location

Carburetor Components

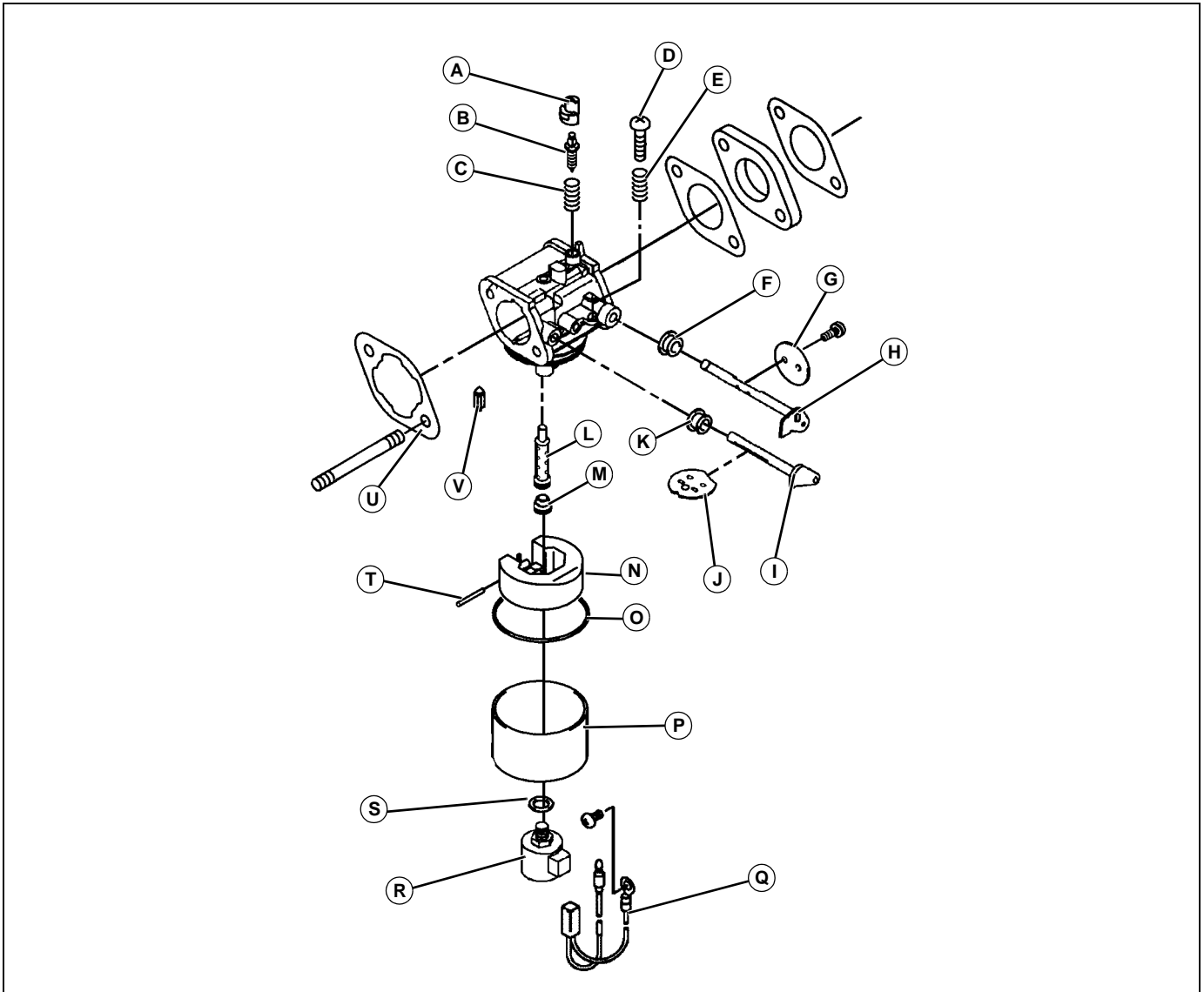

MX19760

- A- Limiter
- B- Pilot Air Screw
- C- Spring
- D- Low Idle Screw
- E- Spring
- F- Seal
- G- Throttle Valve
- H- Throttle Shaft
- I- Choke Shaft
- J- Choke Valve
- K- Seal
- L- Main Nozzle

- M- Valve Seat
- N- Float
- O- Gasket
- P- Float Bowl
- Q- Solenoid Harness
- R- Fuel Solenoid
- S- Gasket
- T- Pin
- U- Gasket
- V- Float Valve

ENGINE - KAWASAKI (FH491V) COMPONENT LOCATION

Engine Block

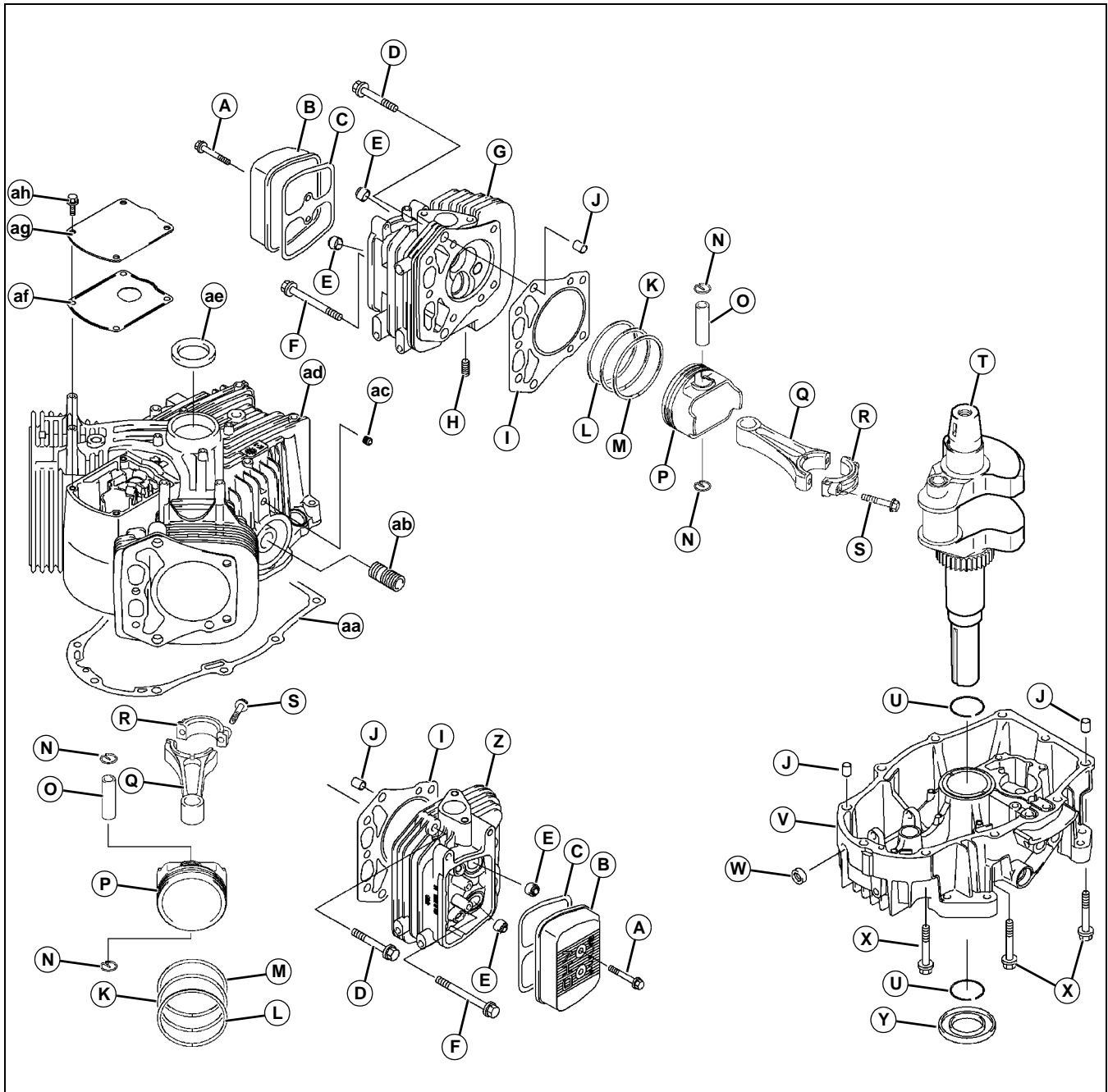

MX39857

- A- Cap Screw M6x12 (4 used)
- B- Valve Cover
- C- Gasket
- D- Bolt (17 used)
- E- Seal
- F- Bolt (2 used)
- G- Cylinder Head No. 1
- H- Stud (4 used)
- I- Head Gasket
- J- Pin (6 used)

- K- Piston Ring, Compression
- L- Piston Ring, Chrome Compression
- M- Piston Ring, Oil Ring Assembly
- N- Snap Ring
- O- Piston Pin
- P- Piston
- Q- Connecting Rod
- R- Connecting Rod Cap
- S- Cap Screw M6x30
- T- Crankshaft
- U- Clip

ENGINE - KAWASAKI (FH491V) COMPONENT LOCATION

V- Crankcase Cover
W- Seal
X- Bolt
Y- Seal
Z- Cylinder Head No. 2
AA- Gasket
AB- Fitting
AC- Plug
AD- Crankcase
AE- Seal
AF- Gasket
AG- Cover
AH- Screw M6x12

ENGINE - KAWASAKI (FH491V) COMPONENT LOCATION

Engine Valves and Governor

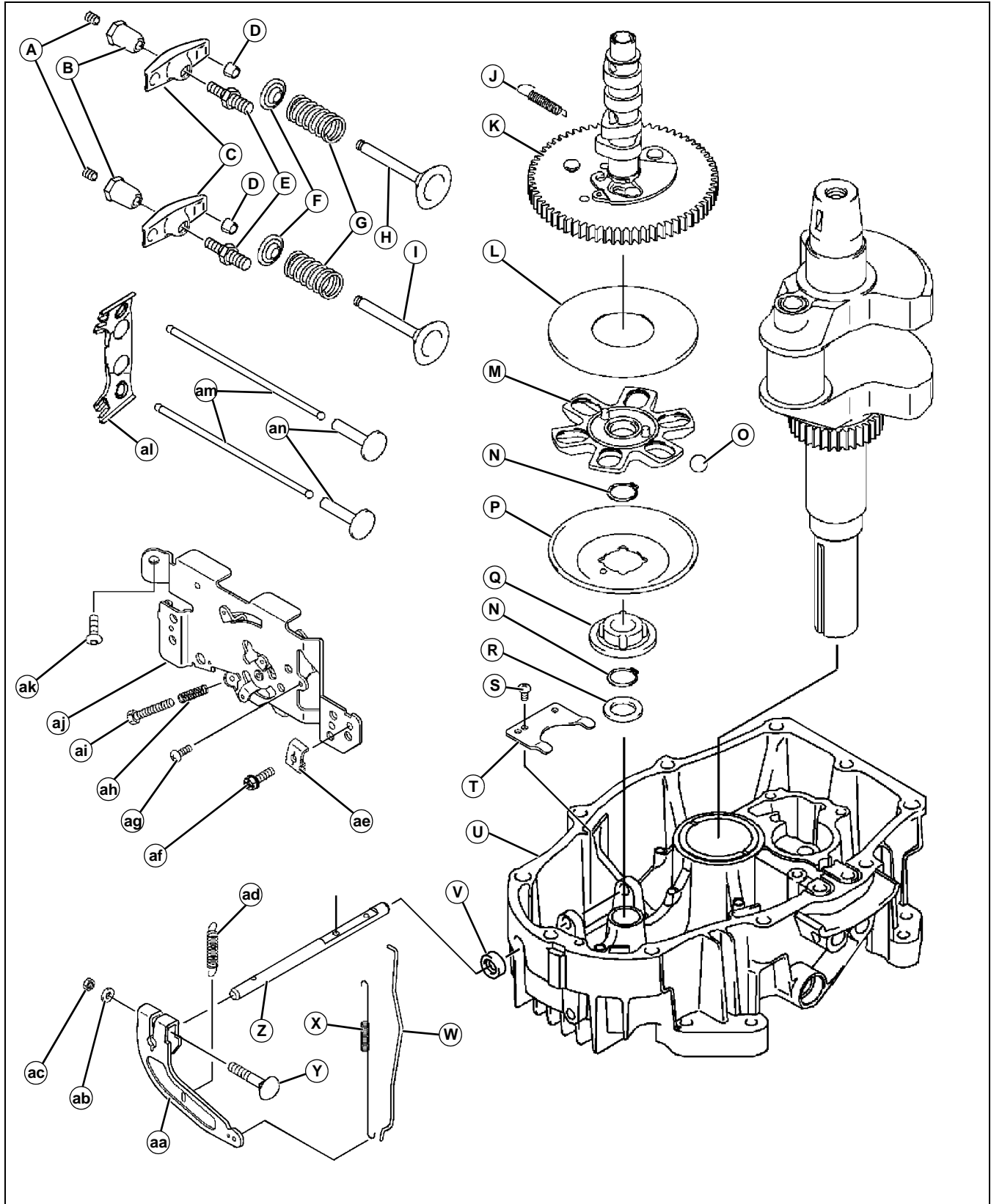

MX37029

A- Lock Screw
B- Rocker Nut

C- Rocker Arm
D- Spring Collet

ENGINE - KAWASAKI (FH491V) COMPONENT LOCATION

E- Stud
F- Spring Retainer
G- Valve Spring
H- Intake Valve
I- Exhaust Valve
J- Spring
K- Cam Shaft
L- Plate
M- Guide
N- Snap Ring
O- Ball
P- Concave Plate
Q- Sleeve
R- Washer
S- Screw
T- Retainer
U- Sump
V- Seal
W- Governor Link
X- Governor Spring
Y- Screw
Z- Governor Shaft
AA- Governor Arm
AB- Washer
AC- Nut
AD- Spring
AE- Cable Retainer
AF- Screw
AG- Screw
AH- Spring
AI- Screw
AJ- Plate
AK- Screw
AL- Pushrod Guide
AM- Pushrod
AN- Tappets

ENGINE - KAWASAKI (FH491V) COMPONENT LOCATION

Engine Shields

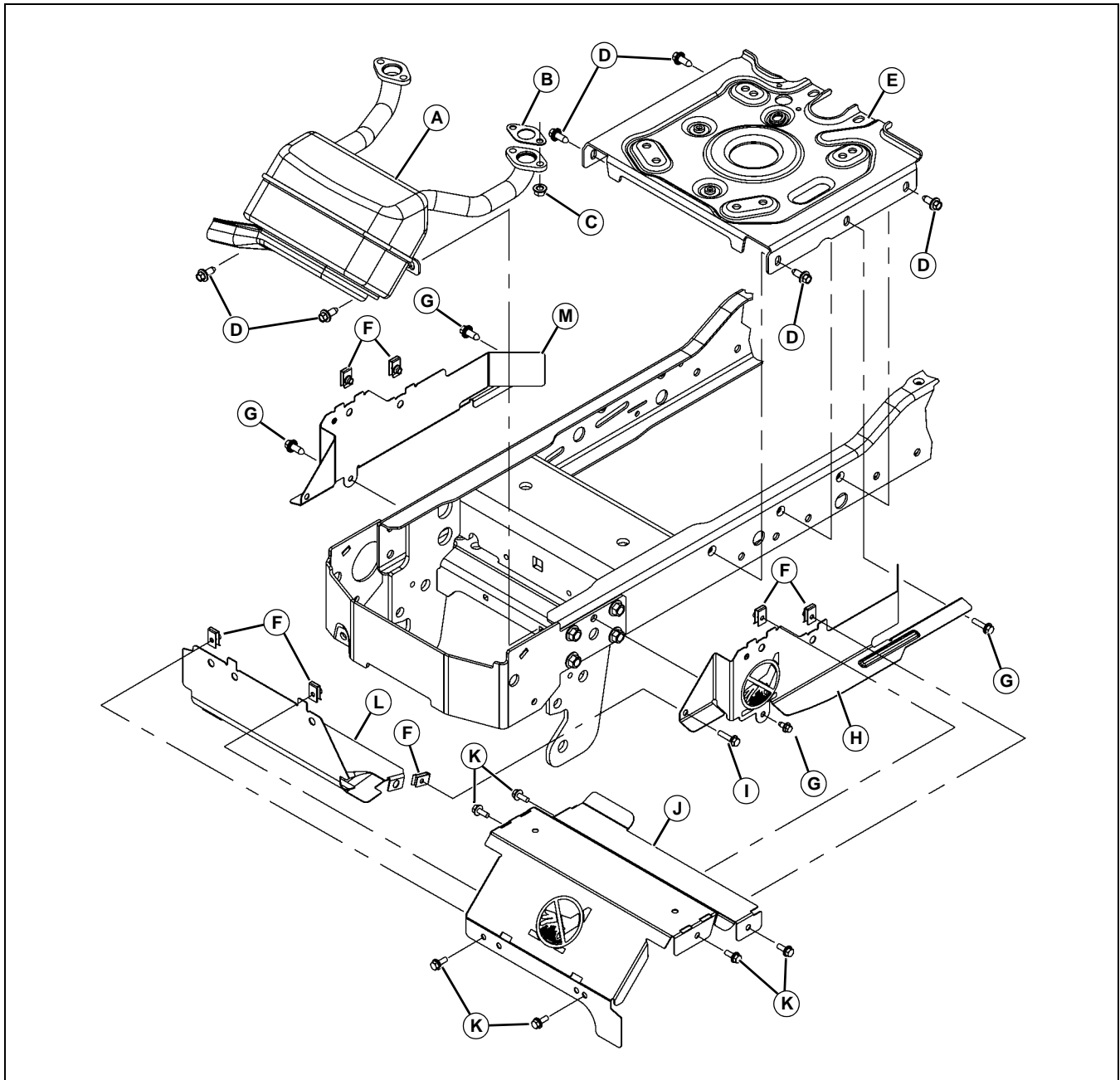

MX37031

L- Shield, Lower
M- Shield RH

- A- Muffler
- B- Gasket (2 used)
- C- Flange Nut M8 (4 used)
- D- Screw (6 used)
- E- Engine Base Plate
- F- Clip Nut (8 used)
- G- Screw M6x25
- H- Shield LH
- I- Screw M6x12
- J- Shield, Upper
- K- Screw M6x16 (6 used)

ENGINE - KAWASAKI (FH491V) THEORY OF OPERATION

Theory of Operation

Engine Oil Flow Chart

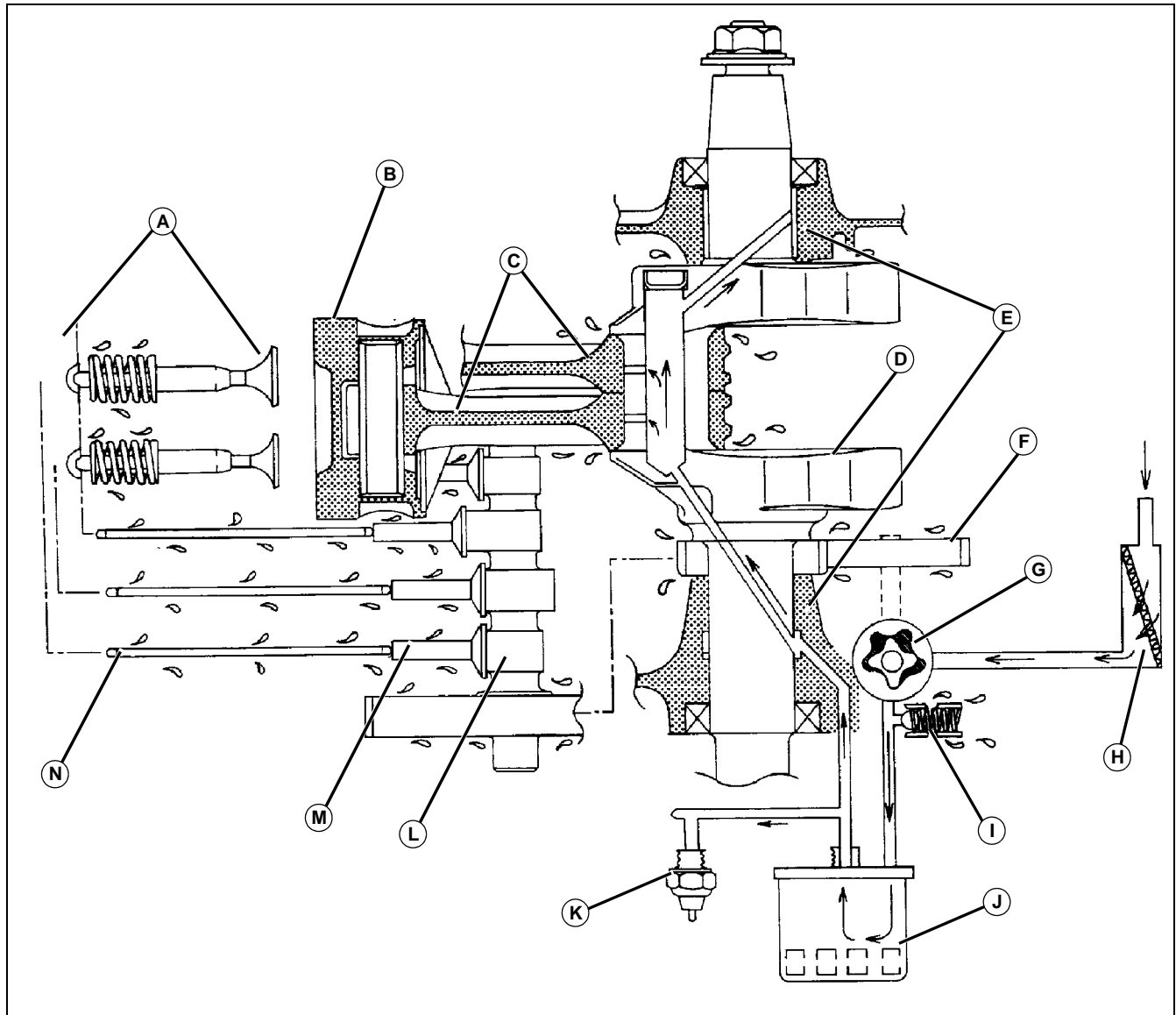

M99565

Lubrication System Operation

- A- Rocker Arms and Valves
- B- Piston
- C- Connecting Rods
- D- Crankshaft
- E- Crankshaft Main Bearings
- F- Oil Pump Gear
- G- Oil Pump
- H- Pick-up Screen
- I- Oil Pressure Relief Valve
- J- Oil Filter
- K- Oil Pressure Sensor
- L- Camshaft
- M- Tappets
- N- Push Rods

Function:

To provide pressurized oil to lubricate internal engine components.

Theory of Operation:

A positive displacement gerotor pump is used to pressurize the lubrication system. The lubrication system is protected by an oil pressure relief valve, low oil pressure switch, and an oil filter with bypass valve.

The oil pump draws oil from the sump through the pick-up screen. Pressure oil from the pump flows through the pump outlet passage past the oil pressure relief valve. The oil pressure relief valve limits the oil pressure to approximately **296 kPa (43 psi)** and protects the oil pump from damage if

ENGINE - KAWASAKI (FH491V) THEORY OF OPERATION

an oil passage becomes blocked. If the oil pressure exceeds 296 kPa (43 psi), the relief valve opens allowing oil to return to the sump. The relief valve is not adjustable.

Pressure oil flows past the relief valve to the oil filter. The filter contains a bypass valve which opens at **78.5 - 117.5 kPa (11.4 - 17.1 psi)** if the element becomes plugged to ensure engine lubrication.

An oil pressure switch mounted above the oil filter turns on a warning light if oil pressure is below **98 kPa (14.2 psi)**. Filtered pressure oil flows through a passage in the oil sump to the crankshaft main bearing (PTO side). Drilled passages in the crankshaft distribute oil from the main bearings to the connecting rod journals and crankshaft main bearings (flywheel side). A drilled passage in the connecting rods allows oil from the connecting rod journal to lubricate the piston and cylinder walls.

In the cylinder head, the rocker arms, valves, and pushrods are lubricated by an oil/air mixture carried through an upper lubrication passage from the breather chamber. As this oil/air mixture is swirled around the rocker arm chamber, the oil particles cling to the moving parts, lubricating them. Eventually these oil particles collect into a liquid state again in the lower portion of the rocker arm chamber. A small return passage is provided to return this liquid state oil back into the crankcase.

The breather creates a negative pressure in the crankcase which prevents oil from being forced out of the engine through the piston rings, oil seals or gaskets. Cylinder blow-by gases go through the crankcase to the breather chamber. They are drawn into the engine side of the air cleaner through the cylinder head and mixed with the clean air flow as part of the emission control system.

The camshaft gear, camshaft, tappets, coolant pump gear, governor gear, oil pump gear, and crankshaft gear are lubricated by oil splash generated by the internal moving parts during operation.

Carburetor Operation

Function

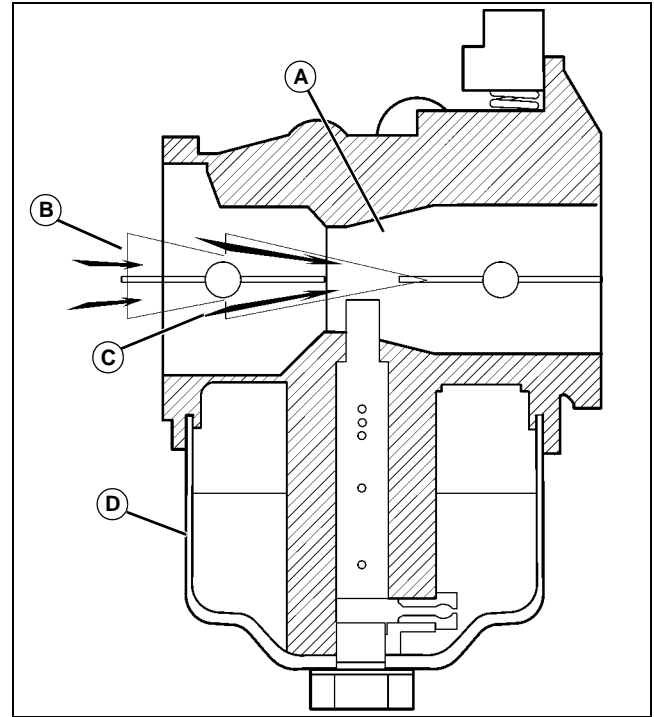

- A- Venturi
- B- Carburetor Throat
- C- Increased Air Speed
- D- Fuel Bowl

The function of the carburetor is to create fuel flow, atomize the fuel, and meter the air/fuel mixture so it can be combusted in the engine. To create fuel flow through the carburetor, there must be a pressure differential between the fuel bowl and the throat of the carburetor.

Venturi

Air goes through the carburetor throat. When it reaches the venturi, the air speed is increased and the air pressure is decreased. The venturi is a restriction in the carburetor located between the choke and throttle valves. The restriction causes air to speed up resulting in a lower than atmospheric pressure area in the carburetor throat.

ENGINE - KAWASAKI (FH491V) THEORY OF OPERATION

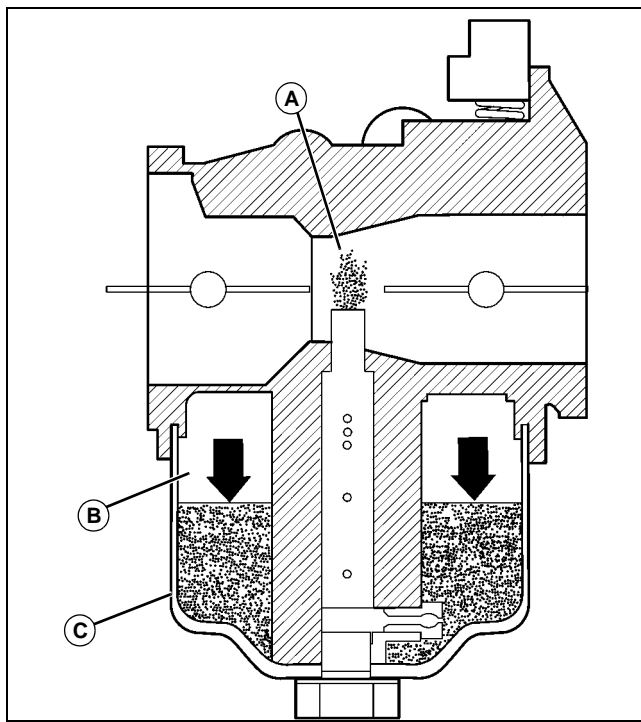

- A- Venturi Low Pressure
- B- High Pressure
- C- Fuel Bowl

A vent passage in the carburetor maintains pressure from the atmosphere on the fuel in the fuel bowl. Since fluids flow from areas of higher pressure to areas of lower pressure the resulting pressure differential between the fuel bowl (high pressure) and the venturi (low pressure), causes fuel to be pushed (flow) from the fuel bowl to the venturi.

There are two types of bowl venting: external and internal.

Note: Late model carburetors are internally vented to meet emissions standards.

Externally vented carburetors exert direct atmospheric pressure from outside of the air filter onto the fuel in the bowl.

Internally vented carburetors exert indirect atmospheric pressure from inside the air filter, ahead of the choke valve, onto the fuel in the bowl.

Fuel Bowl and Float

The fuel bowl is the fuel reservoir for the carburetor. In order to maintain the proper fuel air/mixture, the fuel level must be constant. The float maintains the level of fuel in the bowl while regulating the fuel flow to match the demands of the engine by controlling the inlet float valve (needle).

Control Valves

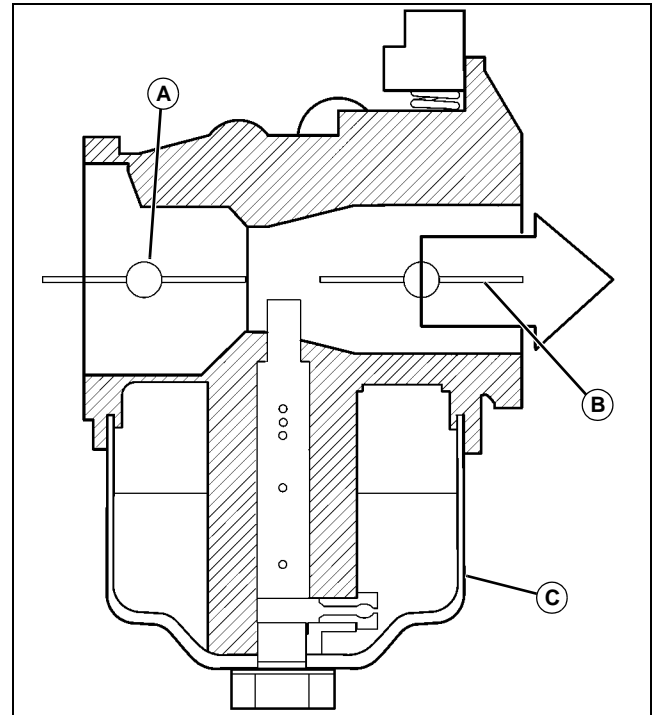

- A- Choke Valve
- B- Throttle Valve
- C- Fuel Bowl

The carburetor has two control valves: throttle valve and choke valve.

The throttle valve is operated by the throttle lever and controlled by the governor. The throttle valve controls how much air and fuel enters the cylinder(s).

The choke valve, located before the venturi, creates a restriction when closed. The function of the choke valve is to increase the pressure differential between the fuel bowl and the venturi area. This results in increased fuel flow from the bowl to the venturi, enriching the air/fuel mixture.

In some engines, a primer is used in place of a choke valve to push fuel into the venturi.

Concept of Idle

Governed engines are designed to maintain a specific engine speed.

Governed engines with no load (PTO disengaged, drive in neutral) are said to be at "idle" regardless of engine speed. When the operator selects the low speed position with no load, the engine is at low idle. When the operator selects the high speed position with no load, the engine is at high idle.

Carbureted engines account for these situations with two circuits; an idle circuit (no load) and a main circuit (under

ENGINE - KAWASAKI (FH491V) THEORY OF OPERATION

load).

Idle Circuit

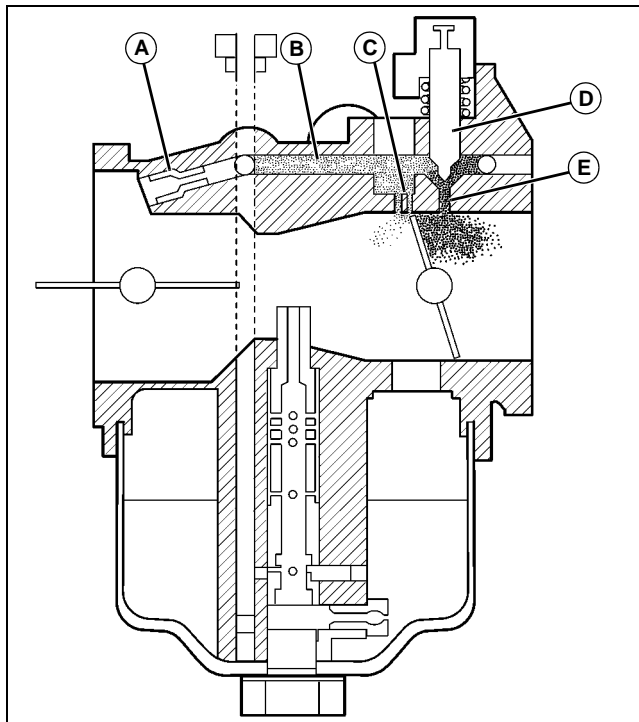

MX47329

- A- Air Bleed
- B- Idle Circuit
- C- Transitional Bypass Openings
- D- Pilot Valve
- E- Pilot Opening

The idle circuit, on a governed engine, delivers air and fuel primarily when the engine is not under load (PTO disengaged, drives in neutral).

Fuel flow enters the idle circuit from the main jet but is metered by the idle jet. The fuel is then emulsified with air passing through an air bleed and combining with the fuel. The air/fuel mixture travels to the transitional bypass openings and the pilot opening.

When the throttle valve is closed, the engine receives its air/fuel mixture through the pilot opening. The pilot opening is used for low idle operation. The pilot opening is located between the closed throttle plate and the intake manifold. The opening has a pilot screw that allows for some adjustment. This adjustment primarily affects low idle.

When the governor slightly opens the throttle valve for high idle or when a load is applied, the transitional bypass openings are exposed. These additional openings increase air/fuel flow to the engine.

Once the engine is under a heavier load, the throttle valve is opened beyond the transitional bypass openings. At this point the carburetor receives fuel primarily from the main

circuit.

Main Circuit

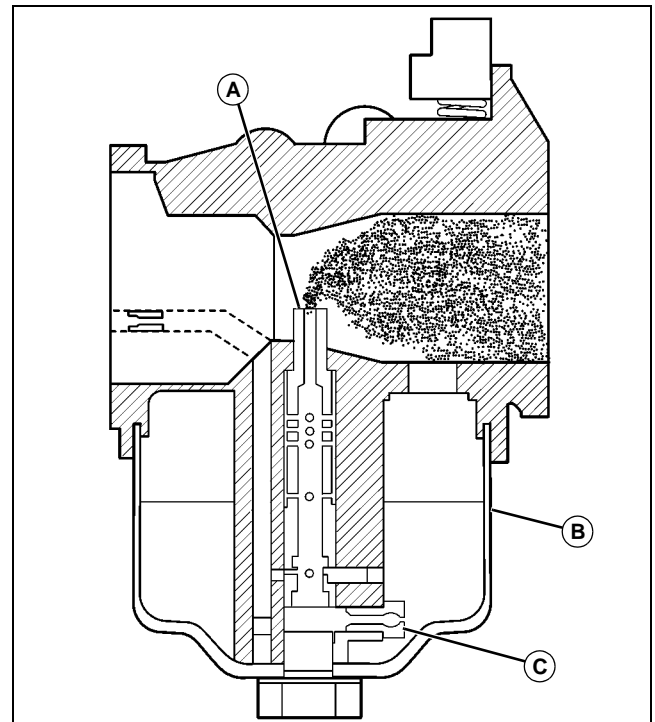

MX47330

- A- Emulsion Tube
- B- Fuel Bowl
- C- Main Jet

The main circuit, on a governed engine, is used only when the engine is under load. Fuel flows from the fuel bowl through the fixed main jet into the main circuit.

Air enters through a metered orifice (air-bleed) and emulsifies (mixes) air and fuel as it travels up the emulsion tube to the venturi.

Emulsification is an important process to properly atomize the fuel and promote efficient combustion.

Fuel Shutoff Solenoid

The fuel shut-off solenoid reduces fuel flow to the main circuit. The function of the fuel shut-off solenoid is to minimize after-bang.

At engine start up, the fuel shut-off solenoid is energized and the poppet retracts from the seat in the bowl, allowing fuel to enter into the main jets.

To bench test the fuel shut-off solenoid, apply light pressure to the tip to simulate its mounting in the fuel bowl and apply 12 volts DC. If the needle retracts, the solenoid is working. Verify the tip is secured to the plunger.

ENGINE - KAWASAKI (FH491V) DIAGNOSTICS

Diagnostics

Engine Troubleshooting Guide



Caution: Avoid Injury! The engine may start to rotate at any time. Keep hands away from moving parts when testing.

Note: To test specific electrical components, see Electrical Section and refer to either Diagnostics or Tests & Adjustments for further guidance.

Test Conditions:

- Operator on seat.
- PTO switch in off position.
- Brake on.

Engine Diagnostics

Engine Doesn't Crank

1. Are battery cables loose or dirty?

Yes: Tighten or clean.

No: Go to next step

2. Is battery fully charged? See "Battery Test" on page 343 in the Electrical section.

Yes: Go to next step

No: Charge Battery. See "Charge Battery" on page 344 in the Electrical Section.

3. Is key switch working correctly?

Yes: Go to next step.

No: Test Switch, Replace as needed.

4. Is starter motor defective? See "Starting Motor Troubleshooting Guide" on page 37.

Yes: Repair or replace.

No: Go to next step.

5. Is alternator defective?

Yes: Repair or replace.

No: Go to next step.

6. Has engine seized?

Yes: See engine Repair Section.

No: Go to next step

7. Is starting motor or solenoid defective?

Yes: Repair or replace. See "Starting Solenoid Test" on page 349.

No: Go to next step.

8. Is there a open circuit in wiring?

Yes: Repair or replace.

No: Go to next step.

9. Is the fuel shutoff solenoid operating correctly?

Yes: Go to next step.

No: Repair or replace.

10. Is the fuel filter or fuel lines clogged?

Yes: Clean or replace as necessary.

No: Go to next step.

11. Is the fuel pump operating correctly? See "Fuel Pump Test" on page 51.

Yes: Go to next step.

No: Clean or replace as necessary.

12. Is their water in the fuel?

Yes: Drain and replace fuel.

No: Go to next step.

13. Are the valves adjusted properly?

Yes: Go to next step.

No: Adjust valve clearance. See "Valve Clearance, Check and Adjustment" on page 47.

14. Does engine have correct compression? See "Cylinder Compression Pressure Test" on page 49.

Yes: Go to next step.

No: Check for seized or burned valves, broken piston rings, or worn cylinder

15. Is air sucked through carburetor or intake manifold flanges?

Yes: Tighten manifold flange nuts or replace damaged gasket.

No: Go to next step

Engine Hard To Start

1. Are battery cables loose or dirty?

Yes: Repair.

No: Go to next step.

2. Is there a strong blue spark? See "Spark Test" on page 51.

Yes: Go to next step.

No: Repair or replace ignition module.

3. Are sparks jumping from produced between high tension lead and ignition block. Check high tension lead, ignition coil air gap, pulser coil.

ENGINE - KAWASAKI (FH491V) DIAGNOSTICS

Yes: Repair or Replace parts as needed

No: Go to next step

4. Is engine compression good? See "Cylinder Compression Pressure Test" on page 49.

Yes: Go to next step.

No: Check piston rings and cylinder for wear. See "Piston Inspection:" on page 67. Inspect Cylinder head. See "Cylinder Head Inspection" on page 61.



Caution: Avoid Injury! Keep spark plug as far away from the plug hole as possible. Gasoline spray from the open cylinders may be ignited by ignition spark and cause an explosion or fire.

5. Make starting attempts a number of times, remove spark plug and observe electrodes. After starting attempts, are spark plug electrodes wet?

Yes: Check for excessive use of choke, plugged air cleaner, float bowl level too high.

No: Go to next step

Engine Runs Erratically

1. Is fuel delivery correct? See "Fuel Pump Test" on page 51.

Yes: Go to next step.

No: Check for defective fuel pump or plugged fuel lines or fuel tank.

2. Is fuel present in carburetor?

Yes: Go to next step.

No: Check for plugged air/fuel passages in carburetor. See "Carburetor Removal, Disassembly, and Installation" on page 55.

3. Is there contamination in fuel lines, or fuel tank?

Yes: Repair or replace parts as needed

No: Go to next step

Engine Malfunctions At Low Speed

1. Is unusual smoke emitted out of muffler?

Yes: Check choke. See "Choke Cable Adjustment" on page 44.

No: Go to next step.

2. Does engine rpm drop or engine stall at a certain point when throttle is gradually opened by hand?

Yes: Check for obstruction or plugged passage in carburetor. See "Carburetor Removal, Disassembly, and Installation" on page 55.

No: Go to next step.

3. Is air sucked through carburetor or intake manifold flanges?

Yes: Tighten manifold flange nuts or replace damaged gasket.

No: Go to next step

4. Are valve clearances set correctly? See "Valve Clearance, Check and Adjustment" on page 47.

Yes: Go to next step.

No: Adjust valves.

Oil Consumption Is Excessive

1. Check for oil leaks, high oil level, clogged breather valve, plugged drain back hole in breather, Is oil viscosity correct?

Yes: Repair as required.

No: Go to next step.

2. Is compression correct? See "Cylinder Compression Pressure Test" on page 49.

Yes: Go to next step.

No: Check for worn, stuck, or broken piston rings, or worn cylinder bore.

Low Oil Pressure

1. Is oil level correct?

Yes: Go to next step.

No: top off oil to correct level.

2. Is oil filter clogged?

Yes: Replace Oil Filter.

No: Go to next step.

3. Is oil of correct viscosity?

Yes: Go to next step.

No: Change engine oil.

4. Check for oil leaks, high oil level, clogged breather valve, plugged drain back hole in breather, Is oil viscosity correct?

Yes: Repair as required.

No: Go to next step.

5. Is oil relief valve worn?

Yes: Clean, adjust or replace relief valve.

No: Go to next step.

6. Is oil pump operating correctly? See "Engine Oil Pressure Test" on page 50.

Yes: Go to next step.

No: Replace oil pump.

7. Is there fuel in the oil?

ENGINE - KAWASAKI (FH491V) DIAGNOSTICS

Yes: Check for broken or seized piston Rings or worn cylinder.

No: Go to next step.

8. Is oil pump screen clogged or pick up tube cracked?

Yes: Clean screen and repair or replace pick up tube.

No: Go to next step.

9. Is there excessive crankshaft or rod bearing clearance?

Yes: Regrind crankshaft and install undersize connecting rods.

No: Go to next step.

10. Intake/exhaust valves or guides worn?

Yes: Replace valves and head.

No: Go to next step.

Contamination in Crankcase

1. Is there fuel in the crankcase?

Yes: Check for broken or seized piston rings or worn cylinder. Check for worn or seized exhaust valve.

No: Go to next step.

2. Is there water in the crankcase?

Yes: Check to make sure that crankcase breather is working correctly. See "Crankcase Vacuum Test" on page 49. See "Breather Inspection" on page 59.

No: Go to next step

Starting Motor Troubleshooting Guide



Caution: Avoid Injury! The engine may start to rotate at any time. Keep hands away from moving parts when testing.

Important: Avoid Damage! If starting motor does not stop rotating by turning ignition switch to Off position, disconnect negative (-) lead from battery as soon as possible.

Note: To test specific electrical components, see Electrical Section and refer to either Diagnostics or Tests & Adjustments for further guidance.

Starting Motor Diagnostics

Starter Does Not Rotate

1. Is there a click sound from the starter solenoid?

Yes: Go to next step.

No: Repair starter motor. See "Starting Motor" on page 76.

2. Check that all starting conditions are met?

Yes: Go to next step.

No: Make sure all starting conditions are met.

3. Are battery cables loose or dirty?

Yes: Clean and tighten.

No: Go to next step.

4. Is battery fully charged? See "Battery Test" on page 343 in the Electrical Section.

Yes: Go to next step.

No: Charge battery. See "Charge Battery" on page 344.

5. Is key switch working correctly?

Yes: Go to next step.

No: Repair or replace key switch

6. Is engine seized?

Yes: See Engine Repair section.

No: Go to next step

Starter Rotates Slowly

1. Are battery cables loose or dirty?

Yes: Clean and Tighten.

No: Go to next step.

2. Is battery fully charged?

Yes: Go to next step.

No: Charge battery. See "Charge Battery" on page 344.

3. Is there a click sound from the starter solenoid?

Yes: Go to next step.

No: Repair starter motor. See "Starting Motor" on page 76.

4. Is engine seized?

Yes: See Engine Repair section.

No: Go to next step

5. Is starting motor or solenoid defective?

Yes: Repair or replace. See "Starting Solenoid Test" on page 349.

No: Go to next step.

Carburetor Troubleshooting Guide

Engine Will Not Start

1. Is there fuel?

ENGINE - KAWASAKI (FH491V) DIAGNOSTICS

Yes: Go to next step.

No: Add fuel, check fuel lines.

2. Is fuel line plugged?

Yes: Clean fuel line and fuel filter. Check for fuel supply at carburetor.

No: Go to next step.

3. Does the fuel solenoid open?

Yes: Go to next step.

No: Test solenoid and power to solenoid. See Electrical section.

4. Is the main jet clogged?

Yes: Disassemble and clean jet and passages.

No: Go to next step.

5. Is the needle valve stuck closed?

Yes: Check for old or gummy fuel. Clean carburetor. Check valve tip.

No: Go to next step.

Engine Cranks But Is Hard to Start

1. Is the air filter clean?

Yes: Go to next step.

No: Clean or replace air filter.

2. Is the choke plate opening properly?

Yes: Go to next step.

No: Adjust choke cable. See choke cable and throttle cable adjustment.

3. Check passages in carburetor. Are passages open and free of debris or varnish?

No: Clean carburetor.

Engine Idles But Does Not Run Under Load

1. Check main jet. Is main jet dirty?

Yes: Clean carburetor.

No: Go to next step.

2. Check main jet for proper size. Is correct main jet used?

No: Replace main jet.

Engine Idles, Runs (loaded or not) Then Stops

1. Is the fuel system properly vented?

Yes: Go to next step.

No: Check fuel cap if vented cap is used. Check vent lines to carburetor for kinks, or collapsed or weak areas.

2. Is dirt in the bowl being sucked into main jet?

Yes: Check float bowl for dirt or corrosion, clean bowl. Check main jet for loose debris.

Engine Does Not Idle Properly (hunts or surges)

1. Check to see if the problem is governor or carburetor: Hold the throttle plate closed to force engine to idle. Does the engine continue to run? check governor. If the engine stalls - suspect idle circuit.

Yes: Check governor for proper operation.

No: If engine stalls, check idle circuit. Clean carburetor with attention to idle circuit passages.

Engine Idles, Does Not Run Properly At Wide Open Throttle (WOT)

1. Check float bowl for dirt or corrosion. Check for dirt between needle valve and seat. Is dirt or debris present?

Yes: Clean bowl and valve seat.

No: Go to next step.

2. Is float sticking or not set properly?

Yes: Clean float pivot. Adjust float.

No: Go to next step.

3. Check air passage and pilot jet for debris or varnish. Is there debris in the idle air bleed or pilot jet?

Yes: Clean carburetor.

Carburetor Air/Fuel Diagnosis

Defects in carburetors would be apparent very early in the life of the engine. The majority of fuel system problems are related to stale or improper fuel or dirt. This section is to help you diagnose fuel system problems.

Initial Checklist

- How old is the fuel?
- Does the fuel have a foul smell?
- Is the fuel cloudy, dark or dirty?
- Is the fuel tank cap air vent clean and open?
- Is a clean, correct air filter installed?
- Has the ignition system been verified?
- Is the air filter and carburetor attached properly?
- Is the intake manifold loose and/or leaking?
- Is the fuel shut-off solenoid operating properly?
- Is the governor throttle linkage moving properly?
- Is the float operating properly?
- If the carburetor is externally vented, is the vent line unrestricted?

ENGINE - KAWASAKI (FH491V) DIAGNOSTICS

Note: Other engine failures such as plugged exhaust or improper valve clearance can cause symptoms similar to faulty fuel supply. Verify the quality of the engines mechanical and electrical systems.

Engine Surge

An engine that surges may have an improper air/fuel mixture or a misadjusted or worn governor.

Attempt to manually control the throttle at low and high idle to determine which system is causing the surge. If the engine speed can be held constant check the governor system. If the engine surge cannot be controlled manually, check the fuel system.

Fuel system issues may consist of:

- Improper air/fuel mixture caused by air leaks around the throttle shaft, intake and/or insulator gaskets.
- Minor restrictions inside the carburetor passages from varnish and debris buildup in the idle circuit. Properly cleaning the carburetor will likely fix the problem.

Rich Air/Fuel Mixture

There are several possible causes of a rich running condition such as: improper or stale fuel, short-tripping, air filter, choke adjustment and/or vent tube location.

Note: Verify the ignition system. A rich running condition can have the same symptoms as an improperly operating ignition system.

Float Valve

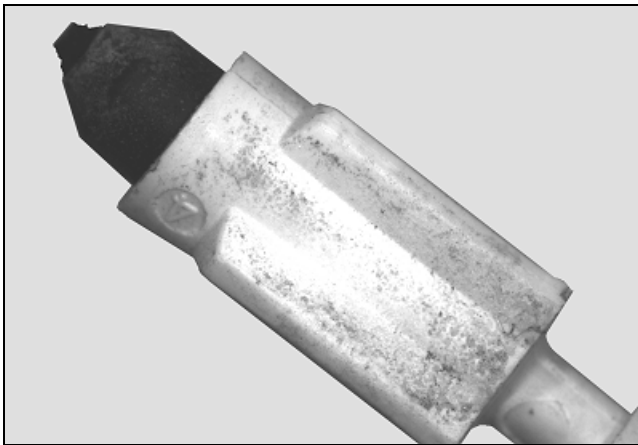

MX47331

Float Valve with Worn Tip Shown

Fuel level in the float bowl is regulated by the float and the float valve. A worn float valve tip provides too much fuel and will cause a rich condition.

Improper or Stale Fuel

Poor fuel quality can cause an engine to appear to be running rich. Improper or stale fuel can cause engine

components to stick or deteriorate.

Short-Tripping

A common misdiagnosis comes from short-tripping machines (engines that are started for short periods of time). Short-tripping causes the engine to develop black, sooty spark plugs and contamination in the oil. Over time, short-tripping can lead to glazed cylinder walls. To prevent this, every time the engine is started, allow the engine to reach operating temperature and load the machine.

Air Filters

Note: Late model carburetors are internally vented to meet emissions standards.

Engines with externally vented carburetors with a dirty air filter will exhibit rich running conditions. When a dirty air filter restricts air flow to the carburetor, the low pressure in the venturi drops even further, resulting in a higher pressure differential between the fuel bowl and the venturi. Therefore, a dirty air filter can enrich the air/fuel mixture to the point that performance will drop.

Engines with internally vented carburetors will not exhibit rich running conditions with a dirty air filter. When a dirty air filter restricts air flow to the throat of the carburetor, an equal reduction will be applied to the bowl vent. Internally vented carburetors maintain the pressure differential between the bowl and the venturi resulting in a consistent air/fuel mixture over the life of the air filter.

Vent Tube Location

With an externally vented carburetor, a rich or lean run condition could also be caused by the location of the float bowl vent tube. The purpose of the vent tube is to allow atmospheric pressure into and out of the float bowl. Air from the cooling fan at the vent tube opening can cause a pressure increase or decrease on the fuel in the float bowl and cause the engine to run rich or lean. Check for bulletins and relocate the float bowl vent tube to a location away from any source of turbulence.

ENGINE - KAWASAKI (FH491V) DIAGNOSTICS

Carburetor Diagnostic Inspection

Inspect the carburetor float bowl and passages for debris, varnish buildup, and corrosion.

Check for damaged parts or parts installed incorrectly.

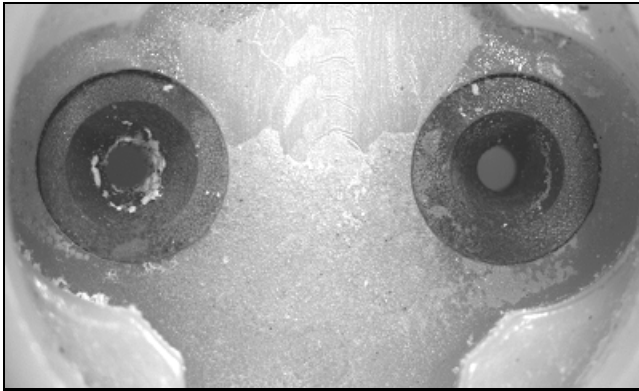

MX47332 and MX47333

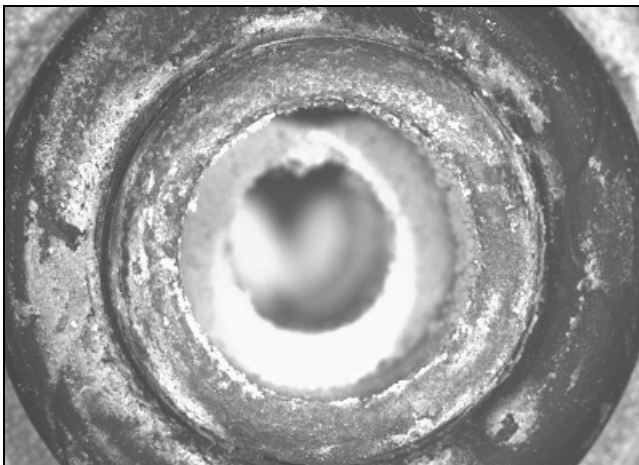

MX47469

1. White corrosion or green corrosion is usually caused by water. Water can combine with other chemicals and create acids and salts which accelerate corrosion. Water can be absorbed by ethanol, so the more ethanol, the worse the problem.

Extreme corrosion may involve salt water. Sometimes the exterior of the carburetor will also be corroded. The location of the machine (such as coastal regions) will provide additional clues to the cause of corrosion.



MX47472

2. Red or brown corrosion is usually caused by an iron or steel part that has corroded. Look at steel fuel inlet fittings, steel parts in fuel filters. It could also indicate some other contaminant in the fuel. Some microbial contaminations can be reddish.

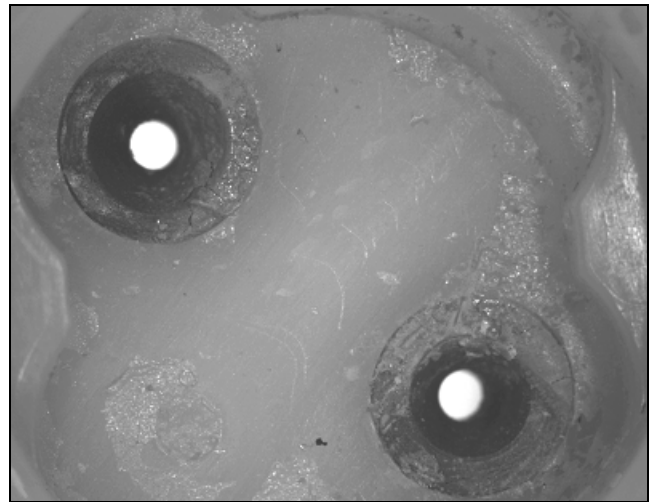

MX47471

3. Brown varnish and gum deposits are generally from old degraded fuel. It usually has a distinctive "old varnish" smell. Look for it in areas that would be adversely affected, such as fuel and air passages, needles and seats.

4. Damage from excessive ethanol, methanol, MTBE, ethers, will usually be seen as damage to rubber parts. Look for cracks, swelling, shrinking, loss of elasticity, takes a permanent set or becomes hard or brittle. Look for plastic damaged parts.

5. Debris stuck in small orifices and other critical areas. Look in jets, fuel and air passages, fuel inlet needle and seat, idle mixture adjustment needles and seats, idle progression holes, fuel shutoff solenoid plunger, etc. The

ENGINE - KAWASAKI (FH491V) GENERAL INFORMATION

material of the debris can help determine the source. Look for the following:

- a. Cellulose and other organic fibers are usually grass debris that was ingested by the engine air intake or fuel system, they could also be fibers from the fuel filter element.
 - b. Sand can come from ingesting dirt by the engine air intake system or fuel system or from unclean manufacturing and parts packaging.
 - c. Metallic particles such as aluminum, brass, and iron chips typically come from the manufacturing process and unclean parts packaging and assembly areas.
 - d. Plastic particles usually come from manufacturing processes such as plastic molding, welding, adhesive (epoxy used in fuel filters), and unclean part packaging and assembly areas.
 - e. Rubber particles usually come from the fuel lines, fuel pump diaphragms, or internal parts, and unclean part packaging and assembly areas.
 - f. Cardboard particles and fibers usually come from parts packaging and unclean assembly areas.
 - g. Hair fibers usually come from unclean parts packaging and assembly areas.
6. Wrong parts, such as wrong size jet or left and right jets switched.
7. Damaged parts, such as jets having tool marks that affect the fuel flow, cracked plastic parts, etc.
8. Defective parts such as porosity in castings, excessive flash on castings or molded parts, defective welds or adhesive joints, throttle shafts that fit too tight or too loose, throttle plates out of alignment or not matched to bores, etc. Defective machining is difficult to diagnose unless it's obvious.

General Information

Cleaning Carburetors

Debris, corrosion, rust, or varnish can build up in the internal air/fuel passages. Many times the contamination is located in an area of the carburetor that is not visible. In most cases proper cleaning can resolve these issues.

Carburetors and carburetor components can be cleaned by using one of several types of commercial cleaning methods: aerosol sprays, caustic dip tanks, and ultrasonic cleaners.

Note: Some cleaning chemicals may be flammable and have toxic fumes. Always follow the chemical manufacturer's recommendations. Always wear personal protection gear such as safety glasses

protective gloves and work in a well ventilated area. Do not use drill or hard wire to clean carburetor passage ways.

Cleaning Procedure

Always follow the solvent manufacturer's recommendations for material compatibility because some solvents may attack metal, plastic or rubber components.

1. Clean debris off the outside of the carburetor before disassembly.
2. Completely disassemble the carburetor per the instructions in the Technical Manual and visually inspect.
3. Determine if carburetor is repairable, excessive corrosion may determine this is not practical.
4. If repairable, clean any remaining dirt and old gaskets from the carburetor.

The preferred method of cleaning is to use an ultrasonic cleaner.

Important: Avoid Damage! Wires and metal instruments should not be used. Light damage or deposits on the surface of the float valve seat can be removed using a cotton swab with a mild abrasive such as toothpaste or 800 grit lapping compound.

Carburetor Assembly

When the carburetor is ready for assembly, lay out all the necessary components on a clean surface. Be aware that even clean shop rags may contain dirt and metal shavings. Assemble the carburetor in accordance with the instructions in the Technical Manual. Keep the following in mind:

- Check the throttle shaft for excessive play or movement and any signs of binding.
- Never use oil on the throttle shaft because it attracts dirt which can cause premature wear of the throttle shaft seals.
- If the throttle shaft was removed use new screws and follow the service manual torque specifications.
- Always check the float and float valve for binding with the float valve installed in its proper position.
- Replacement of all gaskets and seals is necessary when servicing any carburetor.
- Inspect the carburetor insulator for damage and replace if necessary. Be sure to install the insulator using the correct orientation.
- Clean and flush the complete fuel system.
- Fuel lines must be replaced if they are brittle, cracked, excessively soft or damaged.
- Replace the fuel filter and air filter after cleaning the

ENGINE - KAWASAKI (FH491V) GENERAL INFORMATION

carburetor.

Cleaning Methods

Ultrasonic Cleaning Systems

Ultrasonic cleaners use environmentally friendly cleaning solution and sound waves to penetrate deep into carburetor passages. Heating the solution is an option on ultrasonic cleaners that significantly increases the effectiveness of the system. Ultrasonic cleaner systems work by creating sound wave pulses that are transmitted through a cleaning solution. Manufactures of ultrasonic cleaners claim the pulses create small bubbles that loosen and pulverizes contaminates. Select a chemical solution that is designed specifically for carburetor cleaning.

Generally, chemicals will need to be diluted with water prior to use. When choosing a chemical, consider dilution rates to help determine which chemical is the most cost effective. Consider disposal of cleaning solution before ordering chemicals. Check with local authorities on recommended disposal methods before disposing of any cleaning solution. Ultrasonic cleaners come in many sizes. Most 1.5-2 gallon tanks will be sufficient for carburetors used by John Deere gas engines.

If an Ultrasonic Cleaner is used, place carburetor in and run for 30 minutes at 110 F in the proper solution mix. If the solution is too strong or the carburetor is left in the cleaner for too long, the aluminum body will have a residue on the surface from the aluminum oxidizing.



Caution: Avoid Injury! Compressed air can cause debris to fly a long distance.

- Clear work area of bystanders.
- Wear eye protection when using compressed air for cleaning purposes.
- Reduce compressed air pressure to 210 kPa (30 psi).

Rinse the parts in water and dry with compressed air (up to 30 psi).

Wash off and blow ports out in carburetor body/ fuel transfer tubes / and discharge port. Blow compressed air through carburetor passages in the opposite direction of the air/fuel flow (into the smallest passages to flush debris out of the larger passages). This will prevent debris lodging in difficult to clean areas.

Aerosol Cleaner

Personal safety, environmental concerns and cleaning effectiveness make this method the least desirable. This method can be used on carburetor components that may be damaged by caustic cleaners (rubber seals or other

non-metallic components). When cleaning with aerosol sprays, it is always best to spray in the opposite direction of the air/fuel circuit (into the smallest passages to flush debris out of the larger passages). This will prevent debris lodging in difficult to clean areas.



Caution: Avoid Injury! Vapors from solvents can be explosive and flammable. Follow the instructions on the container label for safe use of the solvent:

- Work in a well-ventilated area.
- Wear protective clothing when handling solvent.
- Do not smoke while handling solvents.
- Keep solvent away from flames or sparks.

Caustic Dip Tanks

Caustic dip tanks use aggressive chemicals to dissolve carbon based contamination. This method is effective for most carburetor cleaning needs.

Rotating the parts in the tank will ensure the cleaning solution flushes out any air pockets left in the passages. Follow the recommendation on the cleaner for submersion times. Disadvantages of the caustic dip tanks are that some carburetor parts may be damaged if left in solution too long.

Personal safety and chemical disposal are additional concerns. Because the chemical is caustic, exposure may cause injury or death. Disposal of used solution can be difficult because most cleaners are considered hazardous waste.

Fuel

Use only fuels recommended in Operator's Manual:

Use regular grade unleaded fuel with an octane rating of 87 octane or higher. Fuel blends containing up to 10% ethanol or up to 15% MTBE reformulated fuel are acceptable. DO NOT use fuels with more than 10% ethanol (i.e. E85 should not be used because it is 85% ethanol and 15% gasoline) or fuels with more than 15% MTBE reformulated fuel as these products will damage engine and or fuel system. Do not use fuel or additives containing methanol as engine damage can occur.

All fuel today is formulated for the automotive industry. Fuel is "blended" differently for winter and summer use; regardless of where you are. "Winter" fuel is blended for improved vaporization in colder temperatures. Using left over "Winter" fuel in warmer Spring/Summer temperatures will likely cause vapor locking and surging. Newer carburetors on current production machines have less

ENGINE - KAWASAKI (FH491V) TESTS AND ADJUSTMENTS

tolerance for poor quality fuel because of the tighter specifications required to meet EPA certification.

Fuel Storage

Since it is difficult to know what type of fuel is in different areas; it is best to handle and maintain fuel as outlined below:

1. Deteriorated/stale fuel causes gum and varnish. This creates deposits on engine valves and in carburetor jets and passages. This is what causes most of the performance problems.
2. Oxygenated (or blended) fuels can deteriorate faster and require more specific storage and usage procedures.
3. The translucent fuel tanks on some model tractors allow a certain amount of sunlight through the tank. This can accelerate the deterioration of the fuel.



Caution: Avoid Injury! Fuel stabilizer is a hazardous chemical and can be harmful or fatal if swallowed. Do not take internally. Avoid contact with eyes. Avoid breathing the chemical vapors.

Read safety instructions on stabilizer container label before using.

Fuel stabilizer contains 2,6-di-tert-butylphenol (128-39-2) and aliphatic petroleum distillate (64742-47-8). In case of emergency, contact a physician immediately and call 1-800-424-9300 for material safety information.

Note: There is no fuel stabilizer made that will "restore" stale fuel. Fill tanks with fresh, stabilized fuel.

4. Use fuel from a major name brand supplier. At the same time, add an appropriate amount of Fuel Stabilizer (such as TY25808). Do this when you add fresh fuel to your tank.
5. If engine performance problems arise, try another brand of fuel. You may have to try several different sources.
6. Any fuel over 30 days old is considered "stale".
 - For 2-cycle equipment, purchase as small a quantity of fuel as feasible. If there is doubt about how long the fuel may be stored, add stabilizer right away. JOHN DEERE PREMIUM EXACT MIX 2-Cycle Oil (UP08127) already has a fuel stabilizer added to the oil. When using this oil fuel mix, it will stay fresh for up to 30 days. If storing a 2-cycle powered unit for more than 3 weeks, it is recommended to run the fuel out of the unit.

Tests and Adjustments

Throttle Cable Check and Adjustment

Reason:

- To make sure the throttle control arm has the proper amount of travel for maximum engine performance.

Equipment:

- 6 mm (1/4-in.) Bolt or Drill Bit

Check Procedure:

1. Park machine safely. See "Park Machine Safely" in the Safety section.
2. Remove air filter cover and air filter.

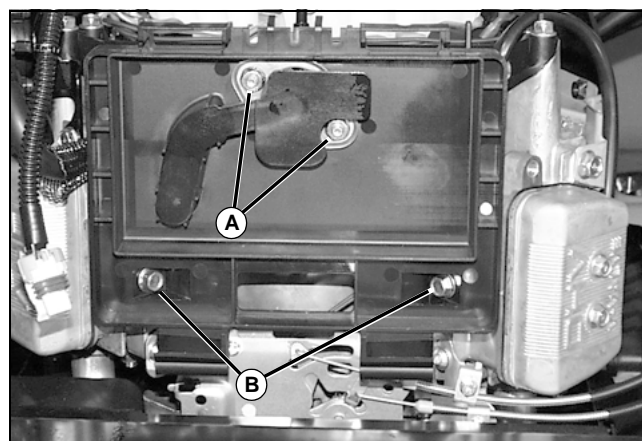

MX37067

3. Remove the two flanged shoulder bolts (B) and two nuts (A) that hold the air cleaner base to the carburetor.
4. Move throttle control lever from SLOW idle to FAST idle position.

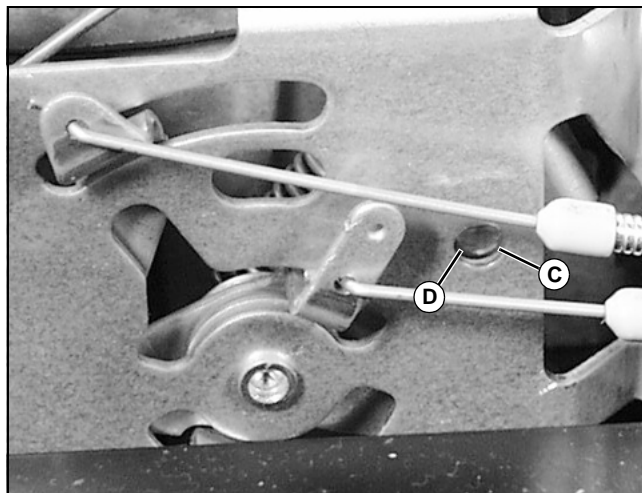

MX37638

5. Check hole alignment in control panel (C) and throttle arm (D) by placing 6mm (1/4-in.) bolt or drill bit in hole. Bolt

ENGINE - KAWASAKI (FH491V) TESTS AND ADJUSTMENTS

must go through both holes.

Results:

- If holes align throttle cable adjustment is OK.
- If holes DO NOT align, perform "Adjustment Procedure" below.

Adjustment Procedure:



Caution: Avoid Injury! Engine components are HOT. Do not touch, exhaust pipe or muffler while making adjustments.

1. Move throttle control lever to FAST.

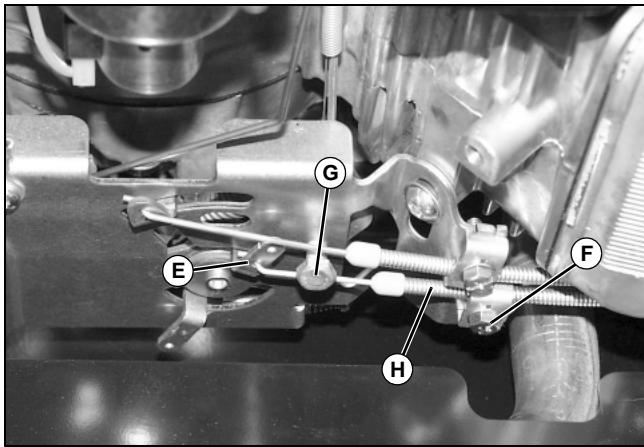

MX38033

2. Loosen cable retainer screw (F).
3. Move throttle arm (E) and throttle cable (H) to align holes in control panel and throttle control plate. Insert a **6 mm (1/4 in.)** bolt (G) or drill bit through holes to keep throttle arm from moving. Be sure bolt or drill bit is perpendicular to the control panel.
4. Make sure throttle control lever on dash is still in FAST position. Tighten retaining screw (F).
5. Remove bolt or drill bit.
6. Repeat "Check Procedure".
7. Move throttle control lever through full range to be sure linkage is not binding.
8. Install air filter housing and air filter.

Choke Cable Adjustment

Reason:

To make sure the choke is fully closed when the choke control lever is in the full choke position.

Procedure:

1. Park machine safely. See "Park Machine Safely" in the Safety section.
2. Remove hood.
3. Remove air filter cover and air filter.

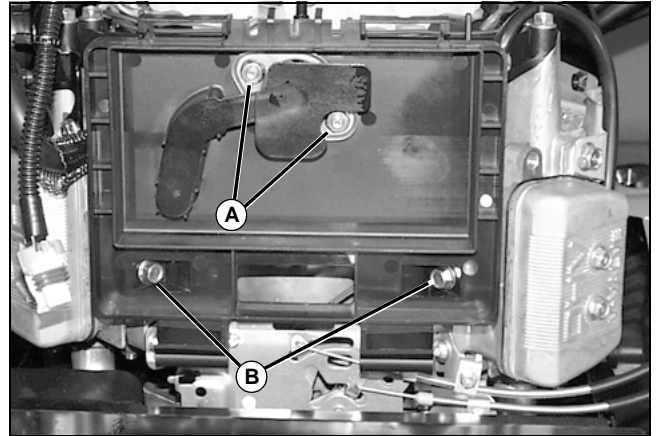

MX37067

4. Remove the two flanged shoulder bolts (B) and two nuts (A) that hold the air cleaner base to the carburetor.

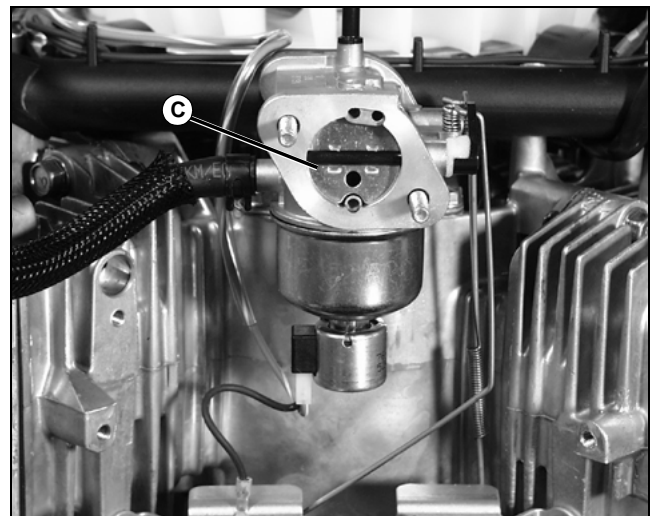

MX37070

5. Move the engine choke lever to the choke position. The carburetor choke butterfly (C) should be fully closed.

ENGINE - KAWASAKI (FH491V) TESTS AND ADJUSTMENTS

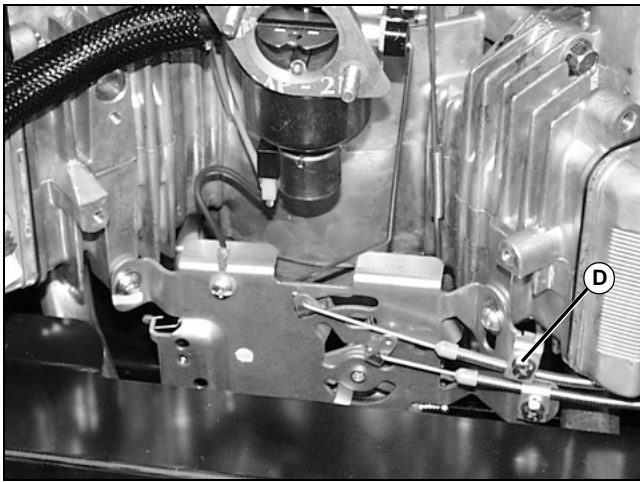

MX37071

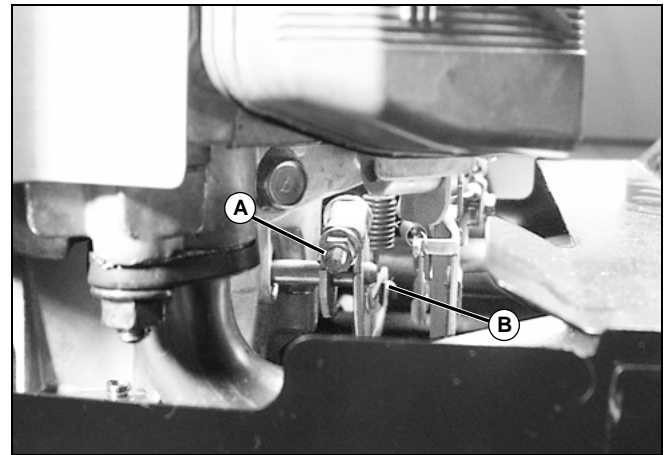

MX37639

6. If the choke butterfly does not completely close, loosen cable clamp (D). Adjust position of choke cable to completely close choke.

7. Move the choke control lever between the choke fully open and fully closed position several times. Ensure the choke plate fully opens and closes. Readjust cable as needed.

Installation is done in the reverse order of removal.

- Tighten fasteners to specification.
- Install hood.

Torque Specifications:

Air Cleaner Base Nuts 6.9 N•m (61 lb-in.)

Air Cleaner Base Screws 3.9 N•m (35 lb-in.)

Governor Adjustment

Reason:

To ensure the governor shaft contacts the flyweight plunger when the engine is stopped.

Procedure:

1. Park machine safely. See "Park Machine Safely" in the Safety section.
2. Move throttle control lever to FAST idle position.

3. Loosen nut (A).



MX37640

4. Insert small pin punch (C) in hole in governor shaft.
5. Hold governor arm (B) in the fully counterclockwise position.
6. Rotate governor shaft counterclockwise as far as it will go.
7. Hold governor shaft and governor arm in place and tighten nut to specification.
8. Move throttle control lever through full range to be sure linkage is not binding.

Specification:

Torque 7.8 N•m (69 lb-in.)

**Thank you very much
for your reading.**

Please Click Here

**Then Get More
Information.**