

ThinkPad

ThinkPad X220 and X220i
Hardware Maintenance Manual

Note: Before using this information and the product it supports, be sure to read the general information under Appendix A “Notices” on page 135.

First Edition (April 2011)

© Copyright Lenovo 2011.

LIMITED AND RESTRICTED RIGHTS NOTICE: If data or software is delivered pursuant a General Services Administration “GSA” contract, use, reproduction, or disclosure is subject to restrictions set forth in Contract No. GS-35F-05925.

Contents

About this manual	iii	Supervisor password	39
Chapter 1. Safety information	1	How to remove the power-on password	39
General safety	1	How to remove the hard-disk password	40
Electrical safety	2	Power management	40
Safety inspection guide	3	Screen blank mode	40
Handling devices that are sensitive to electrostatic discharge	3	Sleep (Standby) mode	41
Grounding requirements	4	Hibernation mode	41
Safety notices (multilingual translations)	4	Symptom-to-FRU index	42
Laser compliance statement (multilingual translations)	16	Numeric error codes	43
Chapter 2. Important service information	23	Error messages	47
Strategy for replacing FRUs	23	Beep symptoms	48
Strategy for replacing a hard disk drive	24	No-beep symptoms	49
Important notice for replacing a system board	24	LCD-related symptoms	49
How to use error message	24	Intermittent problems	49
Strategy for replacing FRUs for CTO, CMV, and GAV	24	Undetermined problems	50
Product definition	24	Chapter 5. Status indicators	51
FRU identification for CTO, CMV, and GAV products	25	Chapter 6. Fn key combinations	53
Chapter 3. General checkout	27	Chapter 7. FRU replacement notices	57
What to do first	27	Screw notices	57
Checkout guide	28	Retaining serial numbers	58
Diagnostics using PC-Doctor for DOS	28	Restoring the serial number of the system unit	58
Lenovo ThinkVantage Toolbox	31	Retaining the UUID	59
PC-Doctor for Windows	31	Reading or writing the ECA information	59
PC-Doctor for Rescue and Recovery	31	Chapter 8. Removing and replacing a FRU	61
FRU tests	31	Before servicing ThinkPad X220 and X220i models	62
Power system checkout	33	1010 Battery pack	63
Checking the ac power adapter	33	1020 Hard disk drive (HDD) and solid state drive (SSD)	63
Checking operational charging	33	1030 DIMM	65
Checking the battery pack	34	1040 Keyboard	67
Checking the backup battery	34	1050 Palm rest or palm rest with a fingerprint reader	69
Chapter 4. Related service information	37	1060 PCI Express Mini Card for wireless LAN/WiMAX	71
Restoring the factory contents by using Product Recovery discs	37	1070 Backup battery	73
Restoring the factory contents by using Recovery Disc Set	37	1080 PCI Express Mini Card for wireless WAN	74
Passwords	39	1090 Keyboard bezel	76
Power-on password	39	1100 LCD assembly	77
Hard-disk password	39	1110 Base cover assembly and speaker assembly	80

1120 Systemboard, DC-in connector, fan, and ExpressCard slot assembly	84
2010 LCD front bezel	88
2020 LED board	89
2030 <i>Bluetooth</i> daughter card (BDC-2.1)	91
2040 Integrated camera	92
2050 LCD panel and LCD cable	93
2060 Hinges	95
2070 LCD rear cover and wireless antenna cables	96
Chapter 9. Locations	99
Front view	100
Rear view.	101
Bottom view	102
Top view (ThinkPad X220 UltraBase)	103
Bottom view (ThinkPad X220 UltraBase).	103
Front View (ThinkPad Port Replicator Series 3)	104
Rear View (ThinkPad Port Replicator Series 3)	104
Front View (ThinkPad Mini Dock Series 3)	105
Rear View (ThinkPad Mini Dock Series 3)	106
Front View (ThinkPad Mini Dock Plus Series 3)	107
Rear View (ThinkPad Mini Dock Plus Series 3)	108
Chapter 10. Parts list	109
Overall	110
LCD FRUs	120

12.5-in. HD LED backlight LCD	121
12.5-in. HD LED backlight premium LCD	123
Keyboard.	123
Miscellaneous parts	125
AC adapters	125
Power cords	125
Recovery discs	126
Windows XP Professional (32 bit) DVDs	126
Windows XP Professional Generic (32bit) DVDs	127
Windows XP Tablet (32 bit) DVDs	128
Windows Vista Business (32 bit) DVDs	128
Windows Vista Home Basic (32 bit) DVDs	128
Windows 7 Professional (32 bit) DVDs.	129
Windows 7 Ultimate (32 bit) DVDs	129
Windows 7 Professional (64 bit) DVDs.	129
Windows 7 Ultimate (64 bit) DVDs	130
Windows 7 Home Basic (32 bit) DVDs.	130
Windows 7 Home Premium (32 bit) DVDs	131
Windows 7 Home Premium (64 bit) DVDs	131
Common service tools	132

Appendix A. Notices	135
Electronic emissions notices	136
Trademarks	136

About this manual

This manual contains service and reference information for the following ThinkPad® products.

ThinkPad X220 and X220i Machine Type 4286, 4287, 4289, 4290, 4291, 4292, and 4293

Use this manual along with the advanced diagnostic tests to troubleshoot problems.

Important:

This manual is intended only for trained service technicians who are familiar with ThinkPad products. Use this manual along with the advanced diagnostic tests to troubleshoot problems effectively. Before servicing a ThinkPad product, be sure to read all the information under Chapter 1 “Safety information” on page 1 and Chapter 2 “Important service information” on page 23.

Chapter 1. Safety information

This chapter presents following safety information that you need to be familiar with before you service a ThinkPad Notebook.

- “General safety” on page 1
- “Electrical safety” on page 2
- “Safety inspection guide” on page 3
- “Handling devices that are sensitive to electrostatic discharge” on page 3
- “Grounding requirements” on page 4
- “Safety notices (multilingual translations)” on page 4
- “Laser compliance statement (multilingual translations)” on page 16

General safety

Follow these rules to ensure general safety:

- Observe good housekeeping in the area of the machines during and after maintenance.
- When lifting any heavy object:
 1. Make sure that you can stand safely without slipping.
 2. Distribute the weight of the object equally between your feet.
 3. Use a slow lifting force. Never move suddenly or twist when you attempt to lift.
 4. Lift by standing or by pushing up with your leg muscles; this action removes the strain from the muscles in your back. *Do not attempt to lift any object that weighs more than 16 kg (35 lb) or that you think is too heavy for you.*
- Do not perform any action that causes hazards to the customer, or that makes the equipment unsafe.
- Before you start the machine, make sure that other service technicians and the customer's personnel are not in a hazardous position.
- Place removed covers and other parts in a safe place, away from all personnel, while you are servicing the machine.
- Keep your toolcase away from walk areas so that other people will not trip over it.
- Do not wear loose clothing that can be trapped in the moving parts of a machine. Make sure that your sleeves are fastened or rolled up above your elbows. If your hair is long, fasten it.
- Insert the ends of your necktie or scarf inside clothing or fasten it with a nonconductive clip, about 8 centimeters (3 inches) from the end.
- Do not wear jewelry, chains, metal-frame eyeglasses, or metal fasteners for your clothing.

Attention: Metal objects are good electrical conductors.

- Wear safety glasses when you are hammering, drilling, soldering, cutting wire, attaching springs, using solvents, or working in any other conditions that might be hazardous to your eyes.
- After service, reinstall all safety shields, guards, labels, and ground wires. Replace any safety device that is worn or defective.
- Reinstall all covers correctly before returning the machine to the customer.
- Fan louvers on the machine help to prevent overheating of internal components. Do not obstruct fan louvers or cover them with labels or stickers.

Electrical safety

Observe the following rules when working on electrical equipment.

Important:

Use only approved tools and test equipment. Some hand tools have handles covered with a soft material that does not insulate you when working with live electrical currents.

Many customers have, near their equipment, rubber floor mats that contain small conductive fibers to decrease electrostatic discharges. Do not use this type of mat to protect yourself from electrical shock.

- Find the room emergency power-off (EPO) switch, disconnecting switch, or electrical outlet. If an electrical accident occurs, you can then operate the switch or unplug the power cord quickly.
- Do not work alone under hazardous conditions or near equipment that has hazardous voltages.
- Disconnect all power before:
 - Performing a mechanical inspection
 - Working near power supplies
 - Removing or installing main units
- Before you start to work on the machine, unplug the power cord. If you cannot unplug it, ask the customer to power-off the wall box that supplies power to the machine, and to lock the wall box in the off position.
- If you need to work on a machine that has *exposed* electrical circuits, observe the following precautions:
 - Ensure that another person, familiar with the power-off controls, is near you.

Attention: Another person must be there to switch off the power, if necessary.

- Use only one hand when working with powered-on electrical equipment; keep the other hand in your pocket or behind your back.

Attention: An electrical shock can occur only when there is a complete circuit. By observing the above rule, you may prevent a current from passing through your body.

- When using testers, set the controls correctly and use the approved probe leads and accessories for that tester.
- Stand on suitable rubber mats (obtained locally, if necessary) to insulate you from grounds such as metal floor strips and machine frames.

Observe the special safety precautions when you work with very high voltages; Instructions for these precautions are in the safety sections of maintenance information. Use extreme care when measuring high voltages.

- Regularly inspect and maintain your electrical hand tools for safe operational condition.
- Do not use worn or broken tools and testers.
- *Never assume* that power has been disconnected from a circuit. First, *check* that it has been powered off.
- Always look carefully for possible hazards in your work area. Examples of these hazards are moist floors, nongrounded power extension cables, power surges, and missing safety grounds.
- Do not touch live electrical circuits with the reflective surface of a plastic dental mirror. The surface is conductive; such touching can cause personal injury and machine damage.
- Do not service the following parts *with the power on* when they are removed from their normal operating places in a machine:
 - Power supply units
 - Pumps
 - Blowers and fans
 - Motor generators
 - Similar units to listed above

This practice ensures correct grounding of the units.

- If an electrical accident occurs:

- Use caution; do not become a victim yourself.
- Switch off power.
- Send another person to get medical aid.

Safety inspection guide

The purpose of this inspection guide is to assist you in identifying potentially unsafe conditions. As each machine was designed and built, required safety items were installed to protect users and service technicians from injury. This guide addresses only those items. You should use good judgment to identify potential safety hazards due to attachment of non-ThinkPad features or options not covered by this inspection guide.

If any unsafe conditions are present, you must determine how serious the apparent hazard could be and whether you can continue without first correcting the problem.

Consider these conditions and the safety hazards they present:

- Electrical hazards, especially primary power (primary voltage on the frame can cause serious or fatal electrical shock)
- Explosive hazards, such as a damaged CRT face or a bulging capacitor
- Mechanical hazards, such as loose or missing hardware

To determine whether there are any potentially unsafe conditions, use the following checklist at the beginning of every service task. Begin the checks with the power off, and the power cord disconnected.

Checklist:

1. Check exterior covers for damage (loose, broken, or sharp edges).
2. Power off the computer. Disconnect the power cord.
3. Check the power cord for:
 - a. A third-wire ground connector in good condition. Use a meter to measure third-wire ground continuity for 0.1 ohm or less between the external ground pin and the frame ground.
 - b. The power cord should be the type specified in the parts list.
 - c. Insulation must not be frayed or worn.
4. Check for cracked or bulging batteries.
5. Remove the cover.
6. Check for any obvious non-ThinkPad alterations. Use good judgment as to the safety of any non-ThinkPad alterations.
7. Check inside the unit for any obvious unsafe conditions, such as metal filings, contamination, water or other liquids, or signs of fire or smoke damage.
8. Check for worn, frayed, or pinched cables.
9. Check that the power-supply cover fasteners (screws or rivets) have not been removed or tampered with.

Handling devices that are sensitive to electrostatic discharge

Any computer part containing transistors or integrated circuits (ICs) should be considered sensitive to electrostatic discharge(ESD). ESD damage can occur when there is a difference in charge between objects. Protect against ESD damage by equalizing the charge so that the machine, the part, the work mat, and the person handling the part are all at the same charge.

Notes:

1. Use product-specific ESD procedures when they exceed the requirements noted here.
2. Make sure that the ESD protective devices you use have been certified (ISO 9000) as fully effective.

When handling ESD-sensitive parts:

- Keep the parts in protective packages until they are inserted into the product.
- Avoid contact with other people.
- Wear a grounded wrist strap against your skin to eliminate static on your body.
- Prevent the part from touching your clothing. Most clothing is insulative and retains a charge even when you are wearing a wrist strap.
- Use a grounded work mat to provide a static-free work surface. The mat is especially useful when handling ESD-sensitive devices.
- Select a grounding system, such as those listed below, to provide protection that meets the specific service requirement.

Note: The use of a grounding system to guard against ESD damage is desirable but not necessary.

- Attach the ESD ground clip to any frame ground, ground braid, or green-wire ground.
- When working on a double-insulated or battery-operated system, use an ESD common ground or reference point. You can use coax or connector-outside shells on these systems.
- Use the round ground prong of the ac plug on ac-operated computers.

Grounding requirements

Electrical grounding of the computer is required for operator safety and correct system function. Proper grounding of the electrical outlet can be verified by a certified electrician.

Safety notices (multilingual translations)

The safety notices in this section are provided in the following languages:

- English
- Arabic
- Brazilian Portuguese
- French
- German
- Hebrew
- Japanese
- Korean
- Spanish
- Traditional Chinese



DANGER

Before the computer is powered on after FRU replacement, make sure all screws, springs, and other small parts are in place and are not left loose inside the computer. Verify this by shaking the computer and listening for rattling sounds. Metallic parts or metal flakes can cause electrical shorts.



DANGER

Some standby batteries contain a small amount of nickel and cadmium. Do not disassemble a standby battery, recharge it, throw it into fire or water, or short-circuit it. Dispose of the battery as required by local ordinances or regulations. Use only the battery in the appropriate parts listing. Use of an incorrect battery can result in ignition or explosion of the battery.



DANGER

The battery pack contains small amounts of nickel. Do not disassemble it, throw it into fire or water, or short-circuit it. Dispose of the battery pack as required by local ordinances or regulations. Use only the battery in the appropriate parts listing when replacing the battery pack. Use of an incorrect battery can result in ignition or explosion of the battery.



DANGER

The lithium battery can cause a fire, an explosion, or a severe burn. Do not recharge it, remove its polarized connector, disassemble it, heat it above 100°C (212°F), incinerate it, or expose its cell contents to water. Dispose of the battery as required by local ordinances or regulations. Use only the battery in the appropriate parts listing. Use of an incorrect battery can result in ignition or explosion of the battery.



DANGER

If the LCD breaks and the fluid from inside the LCD gets into your eyes or on your hands, immediately wash the affected areas with water for at least 15 minutes. Seek medical care if any symptoms from the fluid are present after washing.



DANGER

To avoid shock, do not remove the plastic cover that protects the lower part of the inverter card.



DANGER

Though the main batteries have low voltage, a shorted or grounded battery can produce enough current to burn personnel or combustible materials.



DANGER

Unless hot swap is allowed for the FRU being replaced, do as follows before removing it: power off the computer, unplug all power cords from electrical outlets, remove the battery pack, and disconnect any interconnecting cables.



قبل إعادة تشغيل الحاسب بعد الانتهاء من استبدال FRU، تأكد من أنه قد تم إعادة كل من المسامير و السوست وكل الأجزاء الصغيرة الأخرى في أماكنهم ولم يتم فقدم داخل الحاسب. ويمكن التحقق من ذلك عن طريق هز الحاسب والاستماع لأي صوت صاخب يصدر منه. قد تؤدي الأجزاء أو الرقائق المعدنية إلى حدوث دائرة قصر.



تحتوي بعض البطاريات الاحتياطية على كمية صغيرة من مادتي النيكل والكاديوم. لا تقم بفك أو إعادة شحن البطارية الاحتياطية ولا تقم أيضا بالقائها في النار أو الماء ولا تتسبب في أحداث دائرة قصر بها. قم بالتخلص من البطارية كما هو موضح في القوانين المحلية. استخدم نوع البطارية المحدد والذي يوصى باستخدامه. حيث أنه قد يؤدي استخدام نوع بطارية غير صحيح إلى اشتعالها أو انفجارها.



تحتوي حزمة البطارية على كمية صغيرة من مادة النيكل. لا تقم بفكها أو القاءها في النار أو الماء ولا تتسبب في أحداث دائرة قصر بها. تخلص من حزمة البطارية وفقا لما هو موضح في القوانين المحلية. قم، عند استبدال حزمة البطارية، باستخدام الأنواع المحددة فقط والتي يوصى باستخدامها. حيث أنه قد يؤدي استخدام نوع بطارية غير صحيح إلى اشتعالها أو انفجارها.



قد تتسبب بطارية الليثيوم في حدوث حريق أو انفجار أو حدوث حروق شديدة. لا تقم بإعادة شحن البطارية أو إزالة موصل الاستقطاب الخاص بها ولا تحاول أيضا فكها أو تسخينها لأكثر من ١٠٠ درجة مئوية (٢١٢١ فهرنهايت) أو حرقها أو تعريض محتويات الخانة الخاصة بها للماء. قم بالتخلص من البطارية وفقا لما هو موضح في القوانين المحلية. استخدم نوع البطارية المحدد والذي يوصى باستخدامه. حيث أنه قد يؤدي استخدام نوع بطارية غير صحيح إلى اشتعالها أو انفجارها.



إذا ما انكسرت شاشة LCD ولامس السائل الداخلي عينيك أو يديك، قم في الحال بغسلهما بالماء لمدة لا تقل عن ١٥ دقيقة. إذا ما وجدت أي أعراض بعد الغسل اطلب عندئذ المساعدة الطبية.



خطر

لتجنب التعرض لأي صدمات، لا تلم بازالة الغطاء البلاستيكي الذي يحمي الجزء الأسفل من بطاقة العاكس.



خطر

على الرغم من أن البطاريات الرئيسية يكون لها جهد منخفض، إلا أنه قد تقوم البطاريات التي حدث قصور بها أو التي تم توصيلها أرضيا باصدار تيار يكفي لحدوث حروق للأفراد أو تعرض المواد القابلة للاشتعال للحريق.



خطر

ما لم يتم السماح بالتبديل الفوري لأي FRU الجاري استبداله بدون ضرورة اغلاق النظام، قم بتنفيذ ما يلي قبل ازالته. قم بايقاف تشغيل الحاسب ونزع كل أسلاك الطاقة من المخارج الكهربائية وقم أيضا بازالة حزمة البطارية ثم قم بفصل أي كابلات متصلة.



PERIGO

Antes de ligar o computador após a substituição da FRU, certifique-se de que todos os parafusos, molas e outras peças pequenas estejam no lugar e não estejam soltos dentro do computador. Verifique isso sacudindo o computador e procurando ouvir sons de peças soltas. Peças metálicas ou lascas de metal podem causar curto-circuito.



PERIGO

Algumas baterias reserva contêm uma pequena quantidade de níquel e cádmio. Não desmonte uma bateria reserva, recarregue-a, jogue-a no fogo ou na água, ou deixe-a entrar em curto-circuito. Descarte a bateria conforme requerido pelas leis ou regulamentos locais. Use somente a bateria nas partes listadas apropriadas. O uso de uma bateria incorreta pode resultar em combustão ou explosão da bateria.



PERIGO

O pacote da bateria contém uma pequena quantidade de níquel. Não o desmonte, jogue-o no fogo ou na água, ou deixe-o entrar em curto-circuito. Descarte o pacote da bateria conforme requerido pelas leis ou regulamentos locais. Use somente a bateria nas partes listadas apropriadas ao substituir o pacote da bateria. O uso de uma bateria incorreta pode resultar em combustão ou explosão da bateria.



PERIGO

A bateria de lítio pode causar incêndio, explosão ou graves queimaduras. Não a recarregue, remova seu conector polarizado, desmonte-a, aqueça-a acima de 100°C (212°F), incinere-a, ou exponha o conteúdo de sua célula à água. Descarte a bateria conforme requerido pelas leis ou regulamentos locais. Use somente a bateria nas partes listadas apropriadas. O uso de uma bateria incorreta pode resultar em combustão ou explosão da bateria.



PERIGO

Se o LCD quebrar e o fluido de dentro dele entrar em contato com seus olhos ou com suas mãos, lave as áreas afetadas imediatamente com água durante pelo menos 15 minutos. Procure cuidados médicos se algum sintoma causado pelo fluido surgir após a lavagem.



PERIGO

Para evitar choque elétrico, não remova a capa plástica que protege a parte inferior da placa inversora.



PERIGO

Embora as principais baterias possuam baixa voltagem, uma bateria em curto-circuito ou aterrada pode produzir corrente o bastante para queimar materiais de pessoal ou inflamáveis.



PERIGO

A menos que uma hot swap seja permitida para a FRU que está sendo substituída, faça o seguinte antes de removê-la: desligue o computador, desconecte todos os cabos de energia das tomadas, remova o pacote de baterias e desconecte quaisquer cabos de interconexão.



DANGER

Avant de remettre l'ordinateur sous tension après remplacement d'une unité en clientèle, vérifiez que tous les ressorts, vis et autres pièces sont bien en place et bien fixées. Pour ce faire, secouez l'unité et assurez-vous qu'aucun bruit suspect ne se produit. Des pièces métalliques ou des copeaux de métal pourraient causer un court-circuit.



DANGER

Certaines batteries de secours contiennent du nickel et du cadmium. Ne les démontez pas, ne les rechargez pas, ne les exposez ni au feu ni à l'eau. Ne les mettez pas en court-circuit. Pour les mettre au rebut, conformez-vous à la réglementation en vigueur. Lorsque vous remplacez la pile de sauvegarde ou celle de l'horloge temps réel, veillez à n'utiliser que les modèles cités dans la liste de pièces détachées adéquate. Une batterie ou une pile inappropriée risque de prendre feu ou d'exploser.



DANGER

La batterie contient du nickel. Ne la démontez pas, ne l'exposez ni au feu ni à l'eau. Ne la mettez pas en court-circuit. Pour la mettre au rebut, conformez-vous à la réglementation en vigueur. Lorsque vous remplacez la batterie, veillez à n'utiliser que les modèles cités dans la liste de pièces détachées adéquate. En effet, une batterie inappropriée risque de prendre feu ou d'exploser.



DANGER

La pile de sauvegarde contient du lithium. Elle présente des risques d'incendie, d'explosion ou de brûlures graves. Ne la rechargez pas, ne retirez pas son connecteur polarisé et ne la démontez pas. Ne l'exposez pas à une température supérieure à 100°C, ne la faites pas brûler et n'en exposez pas le contenu à l'eau. Mettez la pile au rebut conformément à la réglementation en vigueur. Une pile inappropriée risque de prendre feu ou d'exploser.



DANGER

Si le panneau d'affichage à cristaux liquides se brise et que vous recevez dans les yeux ou sur les mains une partie du fluide, rincez-les abondamment pendant au moins quinze minutes. Consultez un médecin si des symptômes persistent après le lavage.



DANGER

Afin d'éviter tout risque de choc électrique, ne retirez pas le cache en plastique protégeant la partie inférieure de la carte d'alimentation.



DANGER

Bien que le voltage des batteries principales soit peu élevé, le court-circuit ou la mise à la masse d'une batterie peut produire suffisamment de courant pour brûler des matériaux combustibles ou causer des brûlures corporelles graves.



DANGER

Si le remplacement à chaud n'est pas autorisé pour l'unité remplaçable sur site que vous remplacez, procédez comme suit avant de retirer l'unité : mettez l'ordinateur hors tension, débranchez tous les cordons d'alimentation des prises de courant, retirez le bloc de batterie et déconnectez tous les câbles d'interconnexion.



VORSICHT

Bevor nach einem FRU-Austausch der Computer wieder angeschlossen wird, muß sichergestellt werden, daß keine Schrauben, Federn oder andere Kleinteile fehlen oder im Gehäuse vergessen wurden. Der Computer muß geschüttelt und auf Klappergeräusche geprüft werden. Metallteile oder-splitter können Kurzschlüsse erzeugen.



VORSICHT

Die Bereitschaftsbatterie, die sich unter dem Diskettenlaufwerk befindet, kann geringe Mengen Nickel und Cadmium enthalten. Sie darf nur durch die Verkaufsstelle oder den IBM Kundendienst ausgetauscht werden. Sie darf nicht zerlegt, wiederaufgeladen, kurzgeschlossen, oder Feuer oder Wasser ausgesetzt werden. Die Batterie kann schwere Verbrennungen oder Verätzungen verursachen. Bei der Entsorgung die örtlichen Bestimmungen für Sondermüll beachten. Beim Ersetzen der Bereitschafts- oder Systembatterie nur Batterien des Typs verwenden, der in der Ersatzteilliste aufgeführt ist. Der Einsatz falscher Batterien kann zu Entzündung oder Explosion führen.



VORSICHT

Akkus enthalten geringe Mengen von Nickel. Sie dürfen nicht zerlegt, wiederaufgeladen, kurzgeschlossen, oder Feuer oder Wasser ausgesetzt werden. Bei der Entsorgung die örtlichen Bestimmungen für Sondermüll beachten. Beim Ersetzen der Batterie nur Batterien des Typs verwenden, der in der Ersatzteilliste aufgeführt ist. Der Einsatz falscher Batterien kann zu Entzündung oder Explosion führen.



VORSICHT

Die Systembatterie ist eine Lithiumbatterie. Sie kann sich entzünden, explodieren oder schwere Verbrennungen hervorrufen. Batterien dieses Typs dürfen nicht aufgeladen, zerlegt, über 100°C erhitzt oder verbrannt werden. Auch darf ihr Inhalt nicht mit Wasser in Verbindung gebracht oder der zur richtigen Polung angebrachte Verbindungsstecker entfernt werden. Bei der Entsorgung die örtlichen Bestimmungen für Sondermüll beachten. Beim Ersetzen der Batterie nur Batterien des Typs verwenden, der in der Ersatzteilliste aufgeführt ist. Der Einsatz falscher Batterien kann zu Entzündung oder Explosion führen.



VORSICHT

Die Leuchtstoffröhre im LCD-Bildschirm enthält Quecksilber. Bei der Entsorgung die örtlichen Bestimmungen für Sondermüll beachten. Der LCD-Bildschirm besteht aus Glas und kann zerbrechen, wenn er unsachgemäß behandelt wird oder der Computer auf den Boden fällt. Wenn der Bildschirm beschädigt ist und die darin befindliche Flüssigkeit in Kontakt mit Haut und Augen gerät, sollten die betroffenen Stellen mindestens 15 Minuten mit Wasser abgespült und bei Beschwerden anschließend ein Arzt aufgesucht werden.



VORSICHT

Aus Sicherheitsgründen die Kunststoffabdeckung, die den unteren Teil der Spannungswandlerplatine umgibt, nicht entfernen.



VORSICHT

Obwohl Hauptbatterien eine niedrige Spannung haben, können sie doch bei Kurzschluß oder Erdung genug Strom abgeben, um brennbare Materialien zu entzünden oder Verletzungen bei Personen hervorzurufen.



VORSICHT

Wenn ein Austausch der FRU bei laufendem Betrieb nicht erlaubt ist, gehen Sie beim Austausch der FRU wie folgt vor: Schalten Sie den Computer aus, ziehen Sie alle Netzkabel von den Netzsteckdosen ab, entfernen Sie den Akku und ziehen Sie alle miteinander verbundenen Kabel ab.

סכנה

לפני הפעלת המחשב לאחר החלפת FRU יש לוודא שכל הברגים, הקפיצים, וחלקים קטנים אחרים נמצאים במקומם ואינם חופשיים לזוז בתוך המחשב. כדי לוודא זאת, יש לטלטל את המחשב ולחקשיב לגילוי קולות שקשוק. חלקי או שבבי מתכת עלולים לגרום לקצרים חשמליים.

סכנה

סוללות המתנה מסוימות מכילות כמויות קטנות של ניקל וקדמיום. אין לפרק סוללת המתנה, לטעון אותה מחדש, להשליך אותה לאש או למים או לקצר אותה. יש לסלק את הסוללה כנדרש על ידי התקנות והחוקים המקומיים. יש להשתמש רק בסוללה המופיעה ברישימת החלקים המתאימה. שימוש בסוללה לא מתאימה עלול לגרום להצתה או התמוצצות של הסוללה.

סכנה

מארו הסוללה מכיל כמויות קטנות של ניקל וקדמיום. אין לפרק את מארו הסוללה, להשליך אותו לאש או למים או לקצר אותו. יש לסלק את מארו הסוללה כנדרש על ידי התקנות והחוקים המקומיים. יש להשתמש רק בסוללה המופיעה ברישימת החלקים המתאימה בזמן החלפת מארו הסוללה. שימוש בסוללה לא מתאימה עלול לגרום להצתה או התמוצצות של הסוללה.

סכנה

סוללת הליתיום עלולה לגרום לשריפה, להתמוצות או לכוויות קשות. אין לטעון אותה מחדש, לסלק את המחבר המקוטב שלה, לפרק אותה או לחמם אותה לטמפרטורה העולה על 100 מעלות צלזיוס. אין לשרוף את הסוללה ואין לחשוף את תוכן התא למים. יש לסלק את הסוללה בנדרש בתקנות ובחוקים המקומיים. יש להשתמש רק בסוללה המומיעה ברשימת החלקים המתאימים. שימוש בסוללה אחרת עלול לגרום לסכנת שריפה או התמוצות.

סכנה 

אם מסך חגביש חנוזלי (LCD) נשבר וחגזול מתוך חמסך בא במגע עם עיניכם או ידיכם, שטפו את האזורים הנגועים מיד במים במשך 15 דקות לפחות. פנו לקבלת עזרה רפואית אם תסמינים חנובעים מחמגע עם החגזול נמשכים לאחר החטיפה.

סכנה 

כדי למנוע התחשמלות, אין להסיר את מכסה המלסטיק המגן על חלקו התחתון של הכרטיס ההפך.

סכנה 

אף שהסוללות הראשיות הן בעלות מתח נמוך, סוללה מקוצרת או מוארכת עלולה להפיק זרם מספיק לגרימת כוויות או להצתת חומרים דליקים.

סכנה 

אלא אם כן מותרת 'החלפה חמויה' של ה-FRU המוחלף, פעלו כדלהלן לפני חסרתו: כבו את המחשב, נתקו את כל כבלי החשמל מחשקעים, הוציאו את מארז הסוללות ונתקו את כל הכבלים המחוברים.

 **החלפה חמויה**

FRU של ה-FRU המוחלף, פעלו כדלהלן לפני חסרתו: כבו את המחשב, נתקו את כל כבלי החשמל מחשקעים, הוציאו את מארז הסוללות ונתקו את כל הכבלים המחוברים.

 **החלפה חמויה**

בבטריית ה-FRU המוחלף, פעלו כדלהלן לפני חסרתו: כבו את המחשב, נתקו את כל כבלי החשמל מחשקעים, הוציאו את מארז הסוללות ונתקו את כל הכבלים המחוברים.

 **החלפה חמויה**

בבטריית ה-FRU המוחלף, פעלו כדלהלן לפני חסרתו: כבו את המחשב, נתקו את כל כבלי החשמל מחשקעים, הוציאו את מארז הסוללות ונתקו את כל הכבלים המחוברים.



危険

リチウム・バッテリーは、火災、爆発、または重症のやけどを引き起こすことがあります。バックアップ・バッテリーの充電、その極性コネクタの取り外し、バッテリー本体の分解、100℃(212°F)以上への加熱、焼却、電池の中身を水に浸すことはしないでください。バッテリーを廃棄する場合は地方自治体の条例に従ってください。適切なパーツ・リストにあるバッテリーだけを使用してください。誤ったバッテリーを使用すると、バッテリーが発火したり、爆発したりすることがあります。



危険

LCDが破損し、LCDの中の液体が目に入ったり、手に触れたりした場合は、液体が触れた部分を少なくとも15分間洗い流してください。洗い流した後に、液体によって何らかの症状が現れた場合は、医師の治療を受けてください。



危険

感電を防ぐため、インバーター・カードの下部を保護しているプラスチック・カバーを外さないでください。



危険

メイン・バッテリーの電圧は低くても、ショートしたり、接地したバッテリーが、作業者にやけどを負わせたり、可燃物を燃やすだけの電流を発生させる場合があります。



危険

交換しようとしているFRUがホット・スワップに対応していない場合、それを取り外す前に、コンピューターの電源をオフにし、すべての電源コードをコンセントから抜き、バッテリー・バックを取り外して、相互接続しているケーブルをすべて切り離してください。



위험

FRU를 교체하고 나서 컴퓨터 전원을 켜기 전에 모든 나사, 스프링 및 기타 작은 부품들이 올바른 위치에 있는지, 컴퓨터 내부에 단단하게 연결되어 있는지 확인하십시오. 컴퓨터를 흔들어 달각거리는 소리가 나지 않는지 확인하십시오. 금속 부품 또는 금속 조각은 누전을 일으킬 수 있습니다.



위험

일부 보조 배터리에 소량의 니켈 및 카드뮴이 포함되어 있습니다. 보조 배터리를 분해하거나, 다시 충전하거나, 불 또는 물에 던지거나, 단락시키지 마십시오. 배터리 팩을 폐기할 때에는 해당 지역의 법률 규정을 따르십시오. 배터리 팩을 교체할 때에는 올바른 배터리만 사용하십시오. 올바르게 사용하지 않는 배터리를 사용하면 배터리가 발화되거나 폭발할 수 있습니다.



위험

배터리 팩에는 소량의 니켈이 포함되어 있습니다. 배터리 팩을 분해하거나, 불 또는 물에 던지거나, 단락시키지 마십시오. 배터리 팩을 폐기할 때에는 해당 지역의 법률 규정을 따르십시오. 배터리 팩을 교체할 때에는 올바른 배터리만 사용하십시오. 올바르게 않은 배터리를 사용하면 배터리가 발화되거나 폭발할 수 있습니다.



위험

리튬 배터리는 화재, 폭발 또는 심각한 화상을 일으킬 수 있습니다. 리튬 배터리를 다시 충전하거나, 극성 커넥터를 제거하거나, 분해하거나, 100C(212F) 이상으로 가열하거나, 소각하거나, 전지 내용물을 물에 노출시키지 마십시오. 배터리를 폐기할 때에는 해당 지역을 법률 규정을 따르십시오. 올바른 배터리만 사용하십시오. 올바르게 않은 배터리를 사용하면 배터리가 발화되거나 폭발할 수 있습니다.



위험

LCD가 파손되어 LCD 내부의 액체가 눈에 들어가거나 손에 묻으면 즉시 깨끗한 물로 15분 이상 닦아 내십시오. 씻은 후에 조금이라도 이상을 느끼면 즉시 병원에 가서 의사의 진찰을 받아야 합니다.



위험

전기적 위험을 방지하려면 인버터 카드의 아래 부분을 보호하는 플라스틱 덮개를 제거하지 마십시오.



위험

기본 배터리의 전압은 낮지만, 단락되거나 접지된 배터리는 화상을 입히기에 충분한 전류와 가연성 물질을 발생시킬 수 있습니다.



위험

FRU 교체 시 Hot Swap이 지원되지 않는 경우, FRU를 제거하기 전에 컴퓨터의 전원을 끄고, 전기 콘센트에서 전원 코드를 분리하고, 배터리를 제거한 후, 연결된 모든 케이블을 분리하십시오.



PELIGRO

Antes de encender el sistema despues de sustituir una FRU, compruebe que todos los tornillos, muelles y demás piezas pequeñas se encuentran en su sitio y no se encuentran sueltas dentro del sistema. Compruébelo agitando el sistema y escuchando los posibles ruidos que provocarían. Las piezas metálicas pueden causar cortocircuitos eléctricos.



PELIGRO

Algunas baterías de reserva contienen una pequeña cantidad de níquel y cadmio. No las desmonte, ni recargue, ni las eche al fuego o al agua ni las cortocircuite. Deséchelas tal como dispone la normativa local. Utilice sólo baterías que se encuentren en la lista de piezas. La utilización de una batería no apropiada puede provocar la ignición o explosión de la misma.

 PELIGRO

Las baterías contienen pequeñas cantidades de níquel. No las desmonte, ni recargue, ni las eche al fuego o al agua ni las cortocircuite. Deséchelas tal como dispone la normativa local. Utilice sólo baterías que se encuentren en la lista de piezas al sustituir la batería. La utilización de una batería no apropiada puede provocar la ignición o explosión de la misma.

 PELIGRO

La batería de repuesto es una batería de litio y puede provocar incendios, explosiones o quemaduras graves. No la recargue, ni quite el conector polarizado, ni la desmonte, ni caliente por encima de los 100°C (212°F), ni la incinere ni exponga el contenido de sus celdas al agua. Deséchela tal como dispone la normativa local.

 PELIGRO

Si la LCD se rompe y el fluido de su interior entra en contacto con sus ojos o sus manos, lave inmediatamente las áreas afectadas con agua durante 15 minutos como mínimo. Obtenga atención médica si se presenta algún síntoma del fluido después de lavarse.

 PELIGRO

Para evitar descargas, no quite la cubierta de plástico que rodea la parte baja de la tarjeta invertida.

 PELIGRO

Aunque las baterías principales tienen un voltaje bajo, una batería cortocircuitada o con contacto a tierra puede producir la corriente suficiente como para quemar material combustible o provocar quemaduras en el personal.

 PELIGRO

Salvo que se permita el intercambio en caliente para la unidad sustituible localmente, realice lo siguiente antes de extraerla: apague el sistema, desconecte todos los cables de alimentación de las tomas de alimentación eléctrica, extraiga la batería y desconecte los cables de interconexión.

 危險

完成 FRU 更換之後，在開啟電腦的電源之前，請確定所有螺絲、彈簧及其他小零件都已歸位，沒有遺留在電腦內部。
若要確認這一點，請搖晃電腦，聽聽看是否有卡嗒的聲響。
金屬零件或儀錶的火花會造成電線短路。

 危險

部分備用電池含有微量的鎳和鎘。請勿拆開備用電池、再充電、丟入火或水中，或使其形成短路。請按照當地法令或規定來棄置電池。
僅限使用零件清單中的電池。使用不適當的電池會導致電池起火或爆炸。



危險

電池套件含有微量的鎳。請勿拆開電池套件、丟入火或水中，或使其形成短路。請按照當地法令或規定來棄置電池套件。

更換電池套件時，僅限使用零件清單中的電池。使用不適當的電池會導致電池起火或爆炸。



危險

鋰電池會導致起火、爆炸或嚴重燒傷。請勿再充電、拔除其電極接頭、拆開、加熱超過 100°C (212°F)、焚燒，或讓電池組成物浸到水。請按照當地法令或規定來棄置電池。

僅限使用零件清單中的電池。使用不適當的電池會導致電池起火或爆炸。



危險

如果 LCD 破裂導致 LCD 流出的液體沾到您的眼睛或手，請立即以清水沖洗沾染部位至少 15 分鐘。如果在清洗後出現該液體所造成的任何症狀，請就醫治療。



危險

為避免電擊，請勿拆下轉換卡下面的塑膠護蓋。



危險

雖然主電池的電壓很低，但短路或接地電池所產生的電流，仍足以使人燒傷或使可燃物質起火。



危險

除非 FRU 允許以熱抽換來替換，否則請依下列方式將其移除：將電腦關機，拔除插座上所有電源線，移除電池包，並拔開任何交互連接的線材。

Laser compliance statement (multilingual translations)

The laser compliance statements in this section are provided in the following languages:

- English
- Arabic
- Brazilian Portuguese
- French
- German
- Hebrew
- Japanese
- Korean
- Spanish
- Traditional Chinese



CAUTION:

When laser products (such as CD-ROMs, DVD drives, fiber optic devices, or transmitters) are installed, note the following:

- Do not remove the covers. Removing the covers of the laser product could result in exposure to hazardous laser radiation. There are no serviceable parts inside the device.
- Use of controls or adjustments or performance of procedures other than those specified herein might result in hazardous radiation exposure.



DANGER

Some laser products contain an embedded Class 3A or Class 3B laser diode. Note the following.

Laser radiation when open. Do not stare into the beam, do not view directly with optical instruments, and avoid direct exposure to the beam.



تحذير:

عند تثبيت منتجات الليزر (مثل أقراص CD-ROM أو محركات تشغيل أقراص DVD أو أجهزة الألياف البصرية أو النواقل)، لاحظ ما يلي:

- لا تقم بنزع الغطاء. قد ينتج عن نزع غطاء منتج ليزر التعرض لأشعة ليزر في منتهى الخطورة. لا توجد أجزاء يمكن صيانتها داخل الجهاز.
- قد ينتج عن استخدام مفاتيح أو تنفيذ عمليات ضبط أو إجراءات بطريقة مختلفة عما هو محدد هنا التعرض لأشعة ليزر في منتهى الخطورة.



خطر

تحتوي بعض منتجات الليزر على صمام ثنائي ليزري مضمن من Class 3A أو Class 3B. لاحظ ما يلي. توجد أشعة ليزر عند الفتح. لا تنظر للشعاع ولا تنظر بطريقة مباشرة باستخدام أدوات ضوئية وتجنب التعرض المباشر للشعاع.

**CUIDADO:**

Quando produtos a laser (como CD-ROMs, unidades de DVD, dispositivos de fibra ótica ou transmissores) estão instalados, observe o seguinte:

- Não remova as tampas. A remoção das tampas do produto a laser pode resultar em exposição prejudicial à radiação de laser. Não há peças que permitam manutenção no interior do dispositivo.
- A utilização de controles ou ajustes ou a execução de procedimentos diferentes daqueles especificados aqui pode resultar em exposição perigosa à radiação.

**PERIGO**

Algumas produtos a laser contêm um diodo de laser Classe 3A ou Classe 3B integrado. Observe o seguinte:

Radiação a laser quando aberta. Não olhe diretamente para o feixe a olho nu ou com instrumentos óticos e evite exposição direta ao feixe.

**ATTENTION :**

Si des produits laser (tels que des unités de CD, DVD, à fibre optique ou des émetteurs) sont installés, lisez les informations suivantes :

- Ne retirez pas les carter. En ouvrant le produit laser, vous vous exposez au rayonnement dangereux du laser. Aucune pièce de l'unité n'est réparable.
- Pour éviter tout risque d'exposition au rayon laser, respectez les consignes de réglage et d'utilisation des commandes, ainsi que les procédures décrites dans le présent manuel.

**DANGER**

Certains produits à laser contiennent une diode à laser intégrée de classe 3A ou 3B. Prenez connaissance des informations suivantes.

Rayonnement laser lorsque le carter est ouvert. Evitez toute exposition directe au rayon laser. Evitez de regarder fixement le faisceau ou de l'observer à l'aide d'instruments optiques.



Vorsicht:

Bei der Installation von Lasergeräten (wie CD-ROM-Laufwerken, DVD-Laufwerken, Einheiten mit Lichtwellenleitertechnik oder Sendern) Folgendes beachten:

- Die Abdeckungen nicht entfernen. Durch Entfernen der Abdeckungen des Lasergeräts können gefährliche Laserstrahlungen freigesetzt werden. Das Gerät enthält keine zu wartenden Teile.
- Werden Steuerelemente, Einstellungen oder Durchführungen von Prozeduren anders als hier angegeben verwendet, kann gefährliche Laserstrahlung auftreten.



Gefahr

Einige Lasergeräte enthalten eine Laserdiode der Klasse 3A oder 3B. Beachten Sie Folgendes:

Laserstrahlung bei geöffneter Verkleidung. Nicht in den Strahl blicken. Keine Lupen oder Spiegel verwenden. Strahlungsbereich meiden.



זהירות:

כאשר מוצרי לייזר (כגון תקליטורים, כונני DVD, התקני סיבים אופטיים או משדרים) מותקנים, שימו לב להנחיות

הבאות:

- אל תסירו את הכיסויים. הסרת הכיסויים של מוצר הלייזר עלולה לגרום לחשיפה מסוכנת לקרינת לייזר. ההתקן אינם כוללים רכיבים להחלפה עצמית.
- שימוש בבקרות ובהתאמות שלא צוינו או ביצוע תהליכים שלא צוינו, יכולים לגרום לחשיפה מסוכנת לקרינה.



סכנה

כמה ממוצרי הלייזר מכילים דיודת לייזר מובנית Class 3A או Class 3B. שימו לב לדברים שלהלן. קיימת פליטת קרני לייזר כאשר המוצר פתוח. אל תביטו ישירות אל הקרן, אל תביטו אל הקרן ישירות דרך אמצעים אופטיים, והימנעו מחשיפה ישירה לקרן.



警告:

レーザー製品 (CD-ROM、DVD ドライブ、光ファイバー装置、または送信機など) を取り付ける場合には、以下のことに注意してください。

- カバーを外さないこと。カバーを取り外すと有害なレーザー光を浴びることがあります。この装置の内部には保守が可能な部品はありません。
- 本書で指定された内容以外の、お客様による整備、調整、または手順を行った場合、レーザー放射の危険があります。



危険

一部のレーザー製品には、クラス 3A またはクラス 3B のレーザー・ダイオードが組み込まれています。次の点に注意してください。

開けるとレーザー光が放射されます。光線を見つめたり、光学機械を使って直接見たり、光線を直接浴びることは避けてください。



경고:

레이저 제품 (CD-ROM, DVD 드라이브, 광섬유 장치 또는 송신기) 이 설치되어 있는 경우, 다음과 같은 취급 주의사항을 참고하십시오.

- 덮개를 제거하지 마십시오. 레이저 제품의 덮개를 제거하면 유해한 레이저 복사에 노출될 위험이 있습니다. 장치 내부에는 사용자가 수리할 수 있는 부분이 없습니다.
- 본 내용에서 설명한 이외의 방법으로 드라이브를 조정하거나 제어 또는 작동하는 경우, 해로운 레이저 복사에 노출될 수 있습니다.



위험

일부 레이저 제품은 임베디드 클래스 3A 또는 클래스 3B 레이저 다이오드가 포함되어 있습니다. 다음 주의사항을 유의하십시오.

드라이브의 덮개를 열면 전자파가 발생합니다. 광선 또는 광 장치를 직접 보거나 광선에 노출되지 않도록 주의하십시오.



PRECAUCIÓN:

Cuando haya instalados productos láser (por ejemplo, unidades de CD-ROM, unidades de DVD, dispositivos de fibra óptica o transmisores), tenga en cuenta lo siguiente:

- No extraiga las cubiertas. La extracción de las cubiertas del producto láser podría producir una exposición a radiación láser peligrosa. No hay ninguna pieza dentro del dispositivo que pueda reparar.
- La utilización de controles, ajustes o la realización de procedimientos diferentes a los especificados puede dar como resultado una exposición peligrosa a radiaciones.



PELIGRO

Algunos productos láser contienen un diodo láser de Clase 3A o Clase 3B incorporado. Tenga en cuenta lo siguiente.

Emite radiación láser cuando está abierto. No fije la vista en el rayo, no lo mire directamente con instrumentos ópticos y evite la exposición directa al rayo.



警告：

安裝雷射產品（如 CD-ROM、DVD 光碟機、光纖裝置或轉送器）時，請注意下列事項：

- 請勿卸下外蓋。卸下雷射產品的外蓋可能導致曝露於危險的雷射輻射。裝置內沒有可維修的零件。
- 若不遵守本文規定的控制、調整或操作程序，可能會導致危險的輻射外洩。



危險

某些雷射產品包含內嵌式 3A 類或 3B 類雷射二極體。這類光碟機的使用者應注意下列聲明。

在開啟光碟機時，會有雷射輻射。請勿直視光束或以光學儀器直接觀看光束，並避免直接暴露在光束中。

Chapter 2. Important service information

This chapter presents following important service information that applies to all machine types supported by this manual:

- “Strategy for replacing FRUs” on page 23
 - “Strategy for replacing a hard disk drive” on page 24
 - “Important notice for replacing a system board” on page 24
 - “How to use error message” on page 24
- “Strategy for replacing FRUs for CTO, CMV, and GAV” on page 24
 - “Product definition” on page 24
 - “FRU identification for CTO, CMV, and GAV products” on page 25

Important:

Advise customers to contact the Lenovo Customer Support Center if they need any assistance in obtaining or installing any software fixes, drivers, and UEFI BIOS downloads. Telephone numbers for Lenovo Support are available at:

<http://www.lenovo.com/support/phone>

System Disassembly/Reassembly videos that show the FRU removals or replacements for the Lenovo® authorized service technicians are available in the following support site:

<http://www.lenovoservicetraining.com/ion/>

Advise customers to contact the Customer Support Center at 800-426-7378 if they need assistance in obtaining or installing any software fixes, drivers, and UEFI BIOS downloads.

Customers in Canada should call the Customer Support Center at 800-565-3344 for assistance or download information.

Strategy for replacing FRUs

Before replacing parts:

Make sure that all software fixes, drivers, and UEFI BIOS downloads are installed before replacing any FRUs listed in this manual.

After a system board is replaced, ensure that the latest UEFI BIOS is loaded to the system board before completing the service action.

To download software fixes, drivers, and UEFI BIOS, do as follows:

1. Go to <http://www.lenovo.com/support>.
2. Enter the product number of the computer or press Auto-detect button on the screen.
3. Select **Downloads and drivers**.
4. Follow the directions on the screen and install the necessary software.

Use the following strategy to prevent unnecessary expense for replacing and servicing FRUs:

- **If you are instructed to replace a FRU but the replacement does not correct the problem, reinstall the original FRU before you continue.**
- Some computers have both a processor board and a system board. If you are instructed to replace either the processor board or the system board, and replacing one of them does not correct the problem, reinstall that board, and then replace the other one.

- If an adapter or a device consists of more than one FRU, any of the FRUs may be the cause of the error. Before replacing the adapter or device, remove the FRUs, one by one, to see if the symptoms change. Replace only the FRU that changed the symptoms.

Attention: The setup configuration on the computer you are servicing may have been customized. Running Automatic Configuration may alter the settings. Note the current configuration settings (using the View Configuration option); then, when service has been completed, verify that those settings remain in effect.

Strategy for replacing a hard disk drive

Always try to run a low-level format before replacing a hard disk drive. This will cause all customer data on the hard disk to be lost. Be sure that the customer has a current backup of the data before doing this task.

Attention: The drive startup sequence in the computer you are servicing may have been changed. Be extremely careful during write operations such as copying, saving, or formatting. If you select an incorrect drive, data or programs can be overwritten.

Important notice for replacing a system board

Some components mounted on a system board are very sensitive. Improper handling of a system board can cause damage to those components, and may cause a system malfunction.

Attention: When handling a system board:

- Do not drop a system board or apply any excessive force to it.
- Avoid rough handling of any kind.
- Avoid bending a system board and hard pushing to prevent cracking at each BGA (Ball Grid Array) chipset.

How to use error message

Use the error codes displayed on the screen to diagnose failures. If more than one error code is displayed, begin the diagnosis with the first error code. Whatever causes the first error code may also cause false error codes. If no error code is displayed, see whether the error symptom is listed in the Symptom-to-FRU Index for the computer you are servicing.

Strategy for replacing FRUs for CTO, CMV, and GAV

Product definition

Dynamic Configure To Order (CTO)

This provides the ability for a customer to configure an IBM® or a Lenovo solution from an eSite, and have this configuration sent to fulfillment, where it is built and shipped directly to the customer. The machine label, Product Entitlement Warehouse (PEW), eSupport, and the HMM will load these products as the 4-digit MT and 3-digit model, where model = "CTO" (Example: 1829-CTO).

Custom Model Variant (CMV)

This is a unique configuration that has been negotiated between IBM or Lenovo and the customer. A unique 4-digit MT and 3-digit model is provided to the customer to place orders (Example: 1829-W15). A CMV is a special bid offering. Therefore, it is NOT generally announced.

- The MTM portion of the machine label is the 4-digit MT and 3-digit model, where model = "CTO" (Example: 1829-CTO). The PRODUCT ID portion of the machine label is the 4-digit MT and 3-digit CMV model (Example: 1829-W15).

- The PEW record is the 4-digit MT and 3-digit model, where model = “CTO” (Example: 1829-CTO).
- eSupport will show both the CTO and CMV machine type models (Example: 1829-CTO and 1829-W15 will be found on the eSupport site.)
- The HMM will have the 4-digit MT and 3-digit CTO model only (Example: 1829-CTO). Again, CMVs are custom models and are not found in the HMM.

General Announce Variant (GAV)

This is a standard model (fixed configuration). GAVs are announced and offered to all customers. The MTM portion of the machine label is a 4-digit MT and 3-digit model, where model = a “fixed part number”, not “CTO” (Example: 1829-F1U). Also, PEW, eSupport, and the HMM will list these products under the same fixed model number.

FRU identification for CTO, CMV, and GAV products

There are three information resources to identify which FRUs are used to support CTO, CMV, and GAV products. These sources are PEW, eSupport, and the HMM.

Using PEW

- **PEW** is the primary source for identifying FRU part numbers and FRU descriptions for the key commodities for CTO, CMV and GAV products at a MT - serial number level. An example of key commodities are hard disk drives, system boards, microprocessors, Liquid Crystal Displays (LCDs), and memory.
- Remember, all CTO and CMV products are loaded in PEW under the 4-digit MT and 3-digit model, where model = “CTO” (Example: 1829-CTO). GAVs are loaded in PEW under the 4-digit MT and 3-digit model, where model = a “fixed part number”, not “CTO” (Example: 1829-F1U).
- PEW can be accessed at the following Web site:
<http://www.lenovo.com/support/site.wss/document.do?Indocid=LOOK-WARNTY>
 Select Warranty lookup. Input the MT and the Serial number and the list of key commodities will be returned in the PEW record under COMPONENT INFORMATION.

Using eSupport

For Key Commodities (Examples - hard disk drive, system board, microprocessor, LCD, and memory)

- eSupport can be used to view the list of key commodities built in a particular machine serial (this is the same record found in PEW).
- eSupport can be accessed at the following Web site:
<http://www.lenovo.com/support>
- To view the key commodities, click **Download & Drivers**. And then click **Parts information**. After that click **Parts lookup**. Type in the model type and serial number. The key commodities will be returned in the eSupport record under **Parts shipped with your system**.

For the Remaining FRUs (the complete list of FRUs at the MT Model level)

- eSupport can be used to view the complete list of FRUs for a machine type and model.
- To view the complete list of FRUs, type in the machine type and model (Example: 1829-CTO) under **Quick path**. Under “View by Document Type” select **Parts information**. Under “Filter by Category” select **Service parts**. Under “Parts Information by Date” select **System service parts**. The list of service parts by description, with applicable machine type model and FRU will be displayed.

Using the HMM

For Key Commodities (Examples - hard disk drive, system board, microprocessor, LCD, and memory)

Use the HMM as a back-up to PEW and eSupport to view the complete list of FRUs at the MT Model level.

Chapter 3. General checkout

This chapter presents following information:

- “What to do first” on page 27
- “Checkout guide” on page 28
 - “Diagnostics using PC-Doctor for DOS” on page 28
 - “Lenovo ThinkVantage Toolbox” on page 31
 - “FRU tests” on page 31
- “Power system checkout” on page 33

The descriptions in this chapter apply to any ThinkPad model that supports the PC-Doctor® for DOS diagnostics program. Some descriptions might not apply to your particular computer.

Before you go to the checkout guide, be sure to read the following important notes.

Important notes:

- **Only certified trained personnel should service the computer.**
- **Before replacing any FRU, read the entire page on removing and replacing FRUs.**
- **When you replace FRUs, use new nylon-coated screws.**
- **Be extremely careful during such write operations as copying, saving, or formatting.** Drives in the computer that you are servicing sequence might have been altered. If you select an incorrect drive, data or programs might be overwritten.
- **Replace a FRU only with another FRU of the correct model.** When you replace a FRU, make sure that the model of the machine and the FRU part number are correct by referring to the FRU parts list.
- **A FRU should not be replaced because of a single, unreproducible failure.** Single failures can occur for a variety of reasons that have nothing to do with a hardware defect, such as cosmic radiation, electrostatic discharge, or software errors. Consider replacing a FRU only when a problem recurs. If you suspect that a FRU is defective, clear the error log and run the test again. If the error does not recur, do not replace the FRU.
- **Be careful not to replace a nondefective FRU.**

What to do first

When you do return a FRU, you must include the following information in the parts exchange form or parts return form that you attach to it:

1. Name and phone number of service technician
2. Date of service
3. Date on which the machine failed
4. Date of purchase
5. Failure symptoms, error codes appearing on the display, and beep symptoms
6. Procedure index and page number in which the failing FRU was detected
7. Failing FRU name and part number
8. Machine type, model number, and serial number
9. Customer's name and address

Note: During the warranty period, the customer may be responsible for repair costs if the computer damage was caused by misuse, accident, modification, unsuitable physical or operating environment, or improper maintenance by the customer. Following is a list of some common items that are not covered under warranty and some symptoms that might indicate that the system was subjected to stress beyond normal use.

Before checking problems with the computer, determine whether the damage is covered under the warranty by referring to the following list:

The following are not covered under warranty:

- LCD panel cracked from the application of excessive force or from being dropped
- Scratched (cosmetic) parts
- Distortion, deformation, or discoloration of the cosmetic parts
- Plastic parts, latches, pins, or connectors that have been cracked or broken by excessive force
- Damage caused by liquid spilled into the system
- Damage caused by the improper insertion of a PC Card or the installation of an incompatible card
- Improper disc insertion or use of an optical drive
- Diskette drive damage caused by pressure on the diskette drive cover, foreign material in the drive, or the insertion of a diskette with multiple labels
- Damaged or bent diskette eject button
- Fuses blown by attachment of a nonsupported device
- Forgotten computer password (making the computer unusable)
- Sticky keys caused by spilling a liquid onto the keyboard
- Use of an incorrect ac power adapter on laptop products

The following symptoms might indicate damage caused by nonwarranted activities:

- Missing parts might be a symptom of unauthorized service or modification.
- If the spindle of a hard disk drive becomes noisy, it may have been subjected to excessive force, or dropped.

Checkout guide

Use the following procedures as a guide in identifying and correcting problems with the ThinkPad Notebook.

Note: The diagnostic tests are intended to test only ThinkPad products. The use of non-ThinkPad products, prototype cards, or modified options can lead to false indications of errors and invalid system responses.

1. Identify the failing symptoms in as much detail as possible.
2. Verify the symptoms. Try to re-create the failure by running the diagnostic test or by repeating the operation.

Diagnostics using PC-Doctor for DOS

The ThinkPad Notebook has a test program called PC-Doctor for DOS (hereafter called *PC-Doctor*.) You can detect errors by running the diagnostics test included in PC-Doctor.

Note: PC-Doctor for DOS is available at the following Web site:
<http://www.lenovo.com/support>

To create the PC-Doctor diagnostic CD, follow the instructions on the Web site.

For some possible configurations of the computer, PC-Doctor might not run correctly. To avoid this problem, you need to initialize the computer setup by use of the BIOS Setup Utility before you run PC-Doctor.

To enter BIOS Setup Utility, do as follows:

1. Turn on the computer.
2. When the ThinkPad logo comes up, immediately press F1 to enter the BIOS Setup Utility.

Note: If a supervisor password has been set by the customer, BIOS Setup Utility menu appears after the password is entered. You can start the utility by pressing Enter instead of entering the supervisor password; however, you cannot change the parameters that are protected by the supervisor password.

On the BIOS Setup Utility screen, press F9, Enter, F10, and then Enter.

Note: When you initialize the computer configuration, some devices are disabled, such as the serial port. If you test one of these devices, you will need to enable it by using Configuration utility for DOS. The utility is available on the following Web site:
<http://www.lenovo.com/support>

PC-Doctor cannot be used to test a device that is in the docking station, even if the computer supports the docking station. To test a USB device, connect it to the USB connector of the computer.

Testing the computer

Note: The PC-Doctor diagnostic CD does not support any optical drives connected through USB devices or any others. It supports only the internal optical drive of the ThinkPad Notebook.

To run the test, do as follows:

1. Turn off the computer.
2. Make sure that the internal optical drive that is supported as a startup device is attached to the computer.
3. Turn on the computer. If the computer cannot be powered on, go to “Power system checkout” on page 33, and check the power sources.
If an error code appears, go to “Symptom-to-FRU index” on page 42.
4. When the ThinkPad logo comes up, immediately press F12 to enter the Boot Menu.
5. Insert the PC-Doctor CD into the internal optical drive.
6. Press cursor keys to select **ATAPI CDx** (x: 0, 1, ...) and then press Enter.
7. Follow the instructions on the screen.
8. The main panel of PC-Doctor appears.
9. Select **Diagnostics** with the arrow keys, and press Enter.

Note: You can select an item not only with the arrow keys, but also with the TrackPoint® pointer. Instead of pressing Enter, click the left button.

A pull-down menu appears. (Its exact form depends on the model.)

Note: PC-Doctor menu does not mean the formal support device list. Some unsupported device names may appear in the PC-Doctor menu.

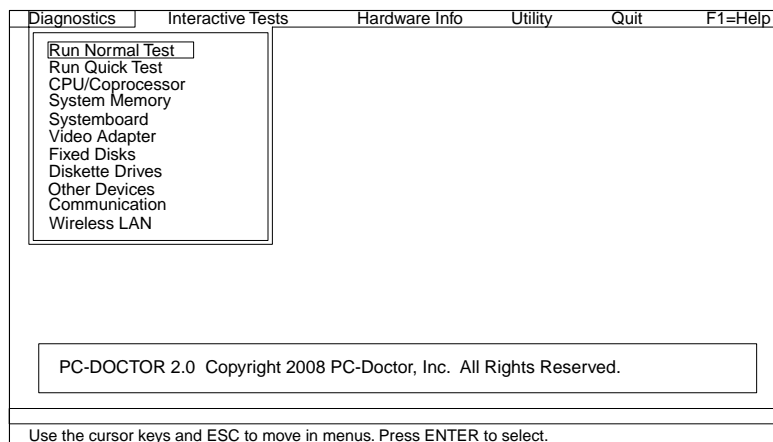

The options on the test menu are as follows:

Diagnostics	Interactive Tests
<ul style="list-style-type: none"> • Run Normal Test • Run Quick Test • CPU/Coprocessor • System board • Video Adapter • Fixed Disks • Diskette Drives • Other Devices • ThinkPad Devices • Communication • Wireless LAN • Advanced Memory Tests 	<ul style="list-style-type: none"> • Keyboard • Video • Internal Speaker • Mouse • Diskette • System Load • Optical Drive Test • Intel WLAN Radio Test
<p>Notes:</p> <ul style="list-style-type: none"> • In the Keyboard test in Interactive Tests, the Fn key should be held down for at least 2 seconds; otherwise, it cannot be sensed. • Video Adapter test supports only the LCD display on the ThinkPad Notebook. If you have an external monitor attached to your computer, detach it before running PC-Doctor for DOS. • To test Digital Signature Chip, the security chip must be set to Active. 	

10. Run the applicable function test.

11. Follow the instructions on the screen. If there is a problem, PC-Doctor shows messages describing it.

12. To exit the test, select **Quit — Exit Diag**. To cancel the test, press Esc.

Note: After running PC-Doctor, check the time and date on the system and reset them if they are incorrect.

Detecting system information with PC-Doctor

PC-Doctor can detect the following system information:

Hardware Info

- System Configuration
- Memory Contents
- Physical Disk Drives
- Logical Disk Drives
- VGA Information
- IDE Drive Info
- PCI Information
- PNPISA Info
- SMBIOS Info
- VESA LCD Info
- Hardware Events Log

Utility

- Run External Tests
- Surface Scan Hard Disk
- Benchmark System
- DOS Shell
- Tech Support Form
- Battery Rundown
- View Test Log
- Print Log
- Save Log
- Full Erase Hard Drive
- Quick Erase Hard Drive

Lenovo ThinkVantage Toolbox

Lenovo ThinkVantage® Toolbox is a diagnostic program that works through the Windows operating system. It enables you to view symptoms of computer problems and solutions for them, and includes automatic notification when action is required, computing assistance, advanced diagnostics, and diagnostic history.

Notes:

- The latest Lenovo ThinkVantage Toolbox is available at the following Web site:
<http://web.lenovothinkvantagetoolbox.com/>
- To install the latest Lenovo ThinkVantage Toolbox on the computer, click **Download Lenovo ThinkVantage Toolbox**, and then follow the instructions on the Web site.

To run this program, do as follows:

Windows 7:

While the Windows operating system is running, press the ThinkVantage button.

To start this program, do the following:

- Click **Start → Control Panel → System and Security → Lenovo's System Health and Diagnostics**.

Windows Vista and Windows XP:

Click **Start → All Programs → ThinkVantage → Lenovo ThinkVantage Toolbox**

Follow the instructions on the screen. Lenovo ThinkVantageToolbox also has problem determination aids that determine software and usage problems.

For additional information about this program, see the Help for the program.

PC-Doctor for Windows

In some models of ThinkPad Notebook, PC-Doctor for Windows enables you to troubleshoot and resolve problems related to the computer.

Select one of the categories listed below to display symptoms and solutions:

- Check System Health
- System and Device Tests
- Lenovo Troubleshooting Center
- System Reports
- Updates and Support

PC-Doctor for Rescue and Recovery

In some models of ThinkPad Notebook, the Rescue and Recovery® workspace enables you to run the PC-Doctor program to test the hardware features of the computer.

To run the test, click “Run Diagnostics” on the Rescue and Recovery main screen.

FRU tests

The following table shows the test for each FRU.

Table 1. FRU tests

FRU	Applicable test
System board	<ol style="list-style-type: none"> 1. Diagnostics → CPU/Coprocessor 2. Diagnostics → Systemboard 3. If the docking station or the port replicator is attached to the ThinkPad Notebook, detach it. 4. Place the computer on a horizontal surface, and run Diagnostics → ThinkPad Devices → HDD Active Protection Test. <p>Note: Do not apply any physical shock to the computer while the test is running.</p>
Power	Diagnostics → ThinkPad Devices → ac power adapter, Battery 1 (Battery2)
LCD unit	<ol style="list-style-type: none"> 1. Diagnostics → Video Adapter 2. Interactive Tests → Video
Audio	Enter the BIOS Setup Utility and change Serial ATA (SATA) setting to Compatibility , and run Diagnostics → Other Device → Conexant Audio .
Speaker	Interactive Tests → Internal Speaker Note: Once Audio test is done, the no sound is heard this test. In this case, turn off and turn on the computer. Then, run this test again.
Keyboard	<ol style="list-style-type: none"> 1. Diagnostics → Systemboard → Keyboard 2. Interactive Tests → Keyboard
Hard disk drive or solid state drive	Enter the BIOS Setup Utility and change Serial ATA (SATA) setting to Compatibility , and run Diagnostics → Fixed Disks . You can also diagnose the drive without starting up the operating system. To diagnose the drive from the BIOS Setup Utility, do as follows: <ol style="list-style-type: none"> 1. Remove any diskette from the diskette drive, and then turn off the computer. 2. Turn on the computer. 3. While the message, "To interrupt normal startup, press the blue ThinkVangate button," is displayed at the lower left of the screen, press F1 to enter the BIOS Setup Utility. 4. Using cursor keys, select HDD diagnostic program. Press enter. 5. Using cursor keys, select Main hard disk drive or Ultrabay hard disk drive. 6. Press Enter to start the diagnostic program.
Diskette drive	<ol style="list-style-type: none"> 1. Diagnostics → Diskette Drives 2. Interactive Tests → Diskette
Optical drive	<ol style="list-style-type: none"> 1. Diagnostics → Other Devices → Optical Drive 2. Interactive Tests → Optical Drive Test
Memory	<ol style="list-style-type: none"> 1. If two DIMMs are installed, remove one of them and run Diagnostics → System Memory. 2. If the problem does not recur, return the DIMM to its place, remove the other one, and run the test again.
TrackPoint or pointing device	If the TrackPoint does not work, check the configuration as specified in the BIOS Setup Utility. If the TrackPoint is disabled, select Automatic to enable it. After you use the TrackPoint, the pointer may drift on the screen for a short time. This drift can occur when a slight, steady pressure is applied to the TrackPoint pointer. This symptom is not a hardware problem. If the pointer stops after a short time, no service action is necessary. If enabling theTrackPoint does not correct the problem, continue with the following: <ul style="list-style-type: none"> • Interactive Tests → Mouse
Touch Pad	If the Touch Pad does not work, check the configuration as specified in the BIOS Setup Utility. If the Touch Pad is disabled, select Automatic to enable it. If enabling the Touch Pad does not correct the problem, continue with the following: <ul style="list-style-type: none"> • Interactive Tests → Mouse

Power system checkout

To verify a symptom, do the following:

1. Turn off the computer.
2. Remove the battery pack.
3. Connect the ac power adapter.
4. Check that power is supplied when you turn on the computer.
5. Turn off the computer.
6. Disconnect the ac power adapter and install the charged battery pack.
7. Check that the battery pack supplies power when you turn on the computer.

If you suspect a power problem, see the appropriate one of the following power supply checkouts:

- “Checking the ac power adapter” on page 33
- “Checking operational charging” on page 33
- “Checking the battery pack” on page 34
- “Checking the backup battery” on page 34

Checking the ac power adapter

You are here because the computer fails only when the ac power adapter is used.

- If the power problem occurs only when the docking station or the port replicator is used, replace the docking station or the port replicator.
- If the power-on indicator does not turn on, check the power cord of the ac power adapter for correct continuity and installation.
- If the computer does not charge during operation, go to “Checking operational charging” on page 33.

To check the ac power adapter, do the following:

1. Unplug the ac power adapter cable from the computer.
2. Measure the output voltage at the plug of the ac power adapter cable. See the following figure:

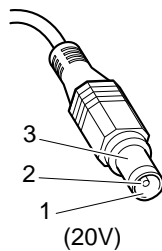

Pin	Voltage (V dc)
1	+20
2	0
3	Ground

Note: Output voltage of pin no.2 of the ac power adapter may differ from the one you are servicing.

3. If the voltage is not correct, replace the ac power adapter.
4. If the voltage is acceptable, do the following:
 - Replace the system board.
 - If the problem persists, go to “FRU tests” on page 31.

Note: Noise from the ac power adapter does not always indicate a defect.

Checking operational charging

To check whether the battery charges properly during operation, use a discharged battery pack or a battery pack that has less than 50% of the total power remaining when installed in the computer.

Perform operational charging. If the battery status indicator or icon does not turn on, remove the battery pack and let it return to room temperature. Reinstall the battery pack. If the charge indicator or icon still does not turn on, replace the battery pack.

If the charge indicator still does not turn on, replace the system board. Then reinstall the battery pack. If it is still not charged, go to the next section.

Checking the battery pack

Battery charging does not start until the Power Manager Battery Gauge shows that less than 96% of the total power remains; under this condition the battery pack can charge to 100% of its capacity. This protects the battery pack from being overcharged or from having a shortened life.

To check your battery, move your cursor to the Power Manager Battery Gauge icon in the icon tray of the Windows taskbar and wait for a moment (but do not click), and the percentage of battery power remaining is displayed. To get detailed information about the battery, double-click the Power Manager Battery Gauge icon.

Note: If the battery pack becomes hot, it may not be able to charge. Remove it from the computer and leave it at room temperature for a while. After it cools down, reinstall and recharge it.

To check the battery pack, do the following:

1. Power off the computer.
2. Remove the battery pack and measure the voltage between battery terminals 1 (+) and 7 (-). See the following figure:

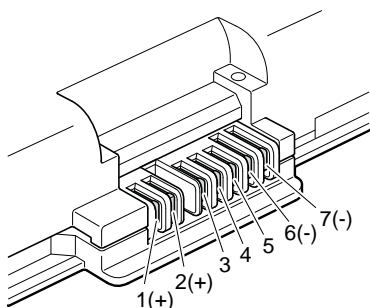

Terminal	Voltage (V dc)
1	+ 0 to + 16.8
7	Ground (-)

3. If the voltage is less than +11.0 V dc, the battery pack has been discharged.

Note: Recharging will take at least 3 hours, even if the indicator does not turn on.

If the voltage is still less than +11.0 V dc after recharging, replace the battery.

4. If the voltage is more than +11.0 V dc, measure the resistance between battery terminals 5 and 7. The resistance must be 4 to 30 K Ω . If the resistance is not correct, replace the battery pack. If the resistance is correct, replace the system board.

Checking the backup battery

Do the following:

1. Power off the computer, and unplug the ac power adapter from it.
2. Turn the computer upside down.
3. Remove the battery pack (see "1010 Battery pack" on page 63).
4. Remove the backup battery (see "1070 Backup battery" on page 73).
5. Measure the voltage of the backup battery. See the following figure.

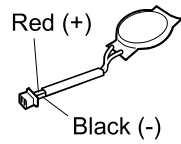

Wire	Voltage (V dc)
Red	+2.5 to +3.2
Black	Ground

- If the voltage is correct, replace the system board.
- If the voltage is not correct, replace the backup battery.
- If the backup battery discharges quickly after replacement, replace the system board.

Chapter 4. Related service information

This chapter presents following information:

- “Restoring the factory contents by using Product Recovery discs” on page 37
- “Restoring the factory contents by using Recovery Disc Set” on page 37
- “Passwords” on page 39
- “Power management” on page 40
- “Symptom-to-FRU index” on page 42

Service Web site:

When the latest maintenance diskette and the system program service diskette become available, they will be posted on <http://www.lenovo.com/support>.

Restoring the factory contents by using Product Recovery discs

When the hard disk drive (HDD) or solid state drive (SSD) is replaced because of a failure, no Product Recovery program is on the new drive. In this case, you must use the recovery discs for the computer. Order the recovery discs and the drive at the same time so that you can recover the new drive with the pre-installed software when they arrive. For information on which discs to order, see “Recovery discs” on page 126.

To install the factory contents by using Product Recovery discs, do the following:

Note: Recovery takes several hours. The length of time depends on the method you use. If you use recovery discs, recovery takes at least five hours.

1. Insert the bootable **Start Recovery Disc** into the DVD drive.
2. Select your language and click **Next**.
3. Read the license. If you agree with the terms, select **I accept these terms and conditions** and then click **Next**.
4. Insert the **Operating System Recovery Disc** when prompted and click **Yes** to begin the operating system recovery process.
5. Insert the **Product Recovery Disc** when prompted and click **OK**.
6. If you have a **Supplemental Recovery Disc**, insert it when prompted and click **Yes**. If you do not have a **Supplemental Recovery Disc**, click **No**.

Note: Not all recovery disc sets come with a **Supplemental Recovery Disc**. If there is a **Supplemental Recovery Disc**, it will be clearly marked as such.

7. When all of the data has been copied from the last disc in the set, a message is displayed prompting you to restart the computer. Remove the disc and then click **Yes**.

Note: The remainder of the recovery process is fully automated and no action is required by you. The computer will restart into the Windows desktop several times and you might experience periods when no activity is apparent on the screen for several minutes at a time. This is normal.

8. When the recovery process is complete, the Welcome to Microsoft Windows screen is displayed. Follow the instructions on the screen to complete the Windows setup.

Restoring the factory contents by using Recovery Disc Set

When the hard disk drive (HDD) or solid state drive (SSD) is replaced because of a failure, no product recovery program is on the new drive. In this case, you must use the Recovery Disc Set for the computer. Order the

Recovery Disc Set and the drive at the same time so that you can recover the new drive with the pre-installed software when they arrive. For information on which discs to order, see “Recovery discs” on page 126.

The recovery disc set consists of the user instructions and the following set of DVDs to restore the computer to the original factory configuration.

<i>Operating System Recovery Disc</i> (one disc)	This disc restores the Microsoft® Windows operating system. Use this disc to start the recovery process.
<i>Applications and Drivers Recovery Disc</i> (one or more discs)	This disc restores the preinstalled applications and drivers on the computer.
<i>Supplemental Recovery Disc</i>	This disc contains additional content, such as updates to the software that was preinstalled on the computer. Not all recovery disc sets come with a <i>Supplemental Recovery Disc</i> .

Notes:

- You must have a DVD drive to use the recovery discs. If you do not have an internal DVD drive, you can use an external USB DVD drive.
- During the recovery process, all data on the drive will be deleted. If possible, copy any important data or personal files that you want to keep onto removable media or a network drive before you start the recovery process.

To restore the computer to the original factory configuration using the recovery disc set, do the following:

Note: Recovery takes several hours. The length of time depends on the method you use. If you use recovery discs, recovery takes at least five hours.

1. Make the CD/DVD drive the first startup device in the startup sequence using the following procedure:
 - a. Press and hold down the F1 key, and then turn on the computer. When the logo screen is displayed or if you hear repeating beeps, release the F1 key. The Setup Utility program opens.
 - b. Use the arrow keys to select **Startup → Boot**.
 - c. Select the CD/DVD drive as the **1st Boot Device**.
2. Insert the *Operating System Recovery Disc* into the DVD drive.
3. Press F10 to save the Setup Utility configuration changes. Follow the instructions on the screen to begin the recovery process.
4. Select your language and click **Next**.
5. Read the license. If you agree with the terms and conditions, select **I accept these terms and conditions** and then click **Next**. If you do not agree with the terms and conditions, follow the instructions on the screen.
6. Click **Yes** in the displayed window to begin the operating system recovery process.
7. Insert the *Applications and Drivers Recovery Disc* when prompted and then click **OK** to begin the applications and drivers recovery process.
8. If you have a *Supplemental Recovery Disc*, insert it when prompted and click **Yes**. If you do not have a *Supplemental Recovery Disc*, click **No**.
9. When all of the data has been copied from the last disc in the set and has been processed, remove the disc and restart the computer.

Note: The rest of the recovery process is fully automated and no action is required by you. The computer will restart into the Microsoft Windows desktop several times and you might experience periods when no activity is apparent on the screen for several minutes at a time. This is normal.

10. When the recovery process is complete, the Set Up Windows screen is displayed. Follow the instructions on the screen to complete the Windows setup.

11. After you have completed the Windows setup, you might want to restore the original startup sequence. Start the Setup Utility program and then press F9 to restore the default settings. Press F10 to save and exit the Setup Utility.

Note: After restoring a drive to the factory default settings, you might need to reinstall some device drivers.

Passwords

As many as three passwords may be needed for any ThinkPad Notebook: the power-on password (POP), the hard-disk password (HDP), and the supervisor password (SVP).

If any of these passwords has been set, a prompt for it appears on the screen whenever the computer is turned on. The computer does not start until the password is entered.

Note: If only an SVP is installed, the password prompt does not appear when the operating system is booted.

Power-on password

A power-on password (POP) protects the system from being powered on by an unauthorized person. The password must be entered before an operating system can be booted. For how to remove the POP, see “How to remove the power-on password” on page 39.

Hard-disk password

There are two hard-disk passwords (HDPs):

- User HDP—for the user
- Master HDP—for the system administrator, who can use it to get access to the hard disk even if the user has changed the user HDP

Note: There are two modes for the HDP: **User only** and **Master + User**. The **Master + User** mode requires two HDPs; the system administrator enters both in the same operation. The system administrator then provides the user HDP to the system user.

Attention: If the user HDP has been forgotten, check whether a master HDP has been set. If it has, it can be used for access to the hard disk drive. If no master HDP is available, neither Lenovo nor Lenovo authorized service technicians provide any services to reset either the user or the master HDP, or to recover data from the hard disk drive. The hard disk drive can be replaced for a scheduled fee.

For how to remove the POP, see “How to remove the hard-disk password” on page 40.

Supervisor password

A supervisor password (SVP) protects the system information stored in the BIOS Setup Utility. The user must enter the SVP in order to get access to the BIOS Setup Utility and change the system configuration.

Attention: If the SVP has been forgotten and cannot be made available to the service technician, there is no service procedure to reset the password. The system board must be replaced for a scheduled fee.

How to remove the power-on password

To remove a POP that you have forgotten, do the following:

(A) If no SVP has been set:

1. Turn off the computer.
2. Remove the battery pack. For how to remove the battery pack, see “1010 Battery pack” on page 63.

3. Remove the backup battery. For how to remove the backup battery, see “1070 Backup battery” on page 73.
4. Turn on the computer and wait until the POST ends. After the POST ends, the password prompt does not appear. The POP has been removed.
5. Reinstall the backup battery and the battery pack.

(B) If an SVP has been set and is known by the service technician:

1. Turn on the computer.
2. When the ThinkPad logo comes up, immediately press F1 to enter ThinkPad Setup. When the POP icon is appearing on the screen, enter the POP.
3. Select **Security**, using the cursor directional keys to move the menu.
4. Select **Password**.
5. Select **Power-On Password**.
6. Type the current SVP in the **Enter Current Password** field. then leave the **Enter New Password** field blank, and press Enter twice.
7. In the Changes have been saved window, press Enter.
8. Press F10; then, in the Setup confirmation window, select **Yes**.

How to remove the hard-disk password

Attention: If **User only** mode is selected and the user HDP has been forgotten and cannot be made available to the service technician, neither Lenovo nor Lenovo authorized service technicians provide any services to reset the user HDPs or to recover data from the hard disk drive. The hard disk drive can be replaced for a scheduled fee.

To remove a user HDP that has been forgotten, when the SVP and the master HDP are known, do the following:

1. Turn on the computer.
2. When the ThinkPad logo comes up, immediately press F1 to enter BIOS Setup Utility. When the POP icon is appearing on the screen, enter the POP.
3. Select **Security**, using the cursor directional keys to move the menu.
4. Select **Password**.
5. Select **Hard-disk x password**, where x is the letter of the hard disk drive. A pop-up window opens.
6. Select **Master HDP**.
7. Type the current master HDP in the **Enter Current Password** field. then leave the **Enter New Password** field blank, and press Enter twice.
8. Press F10.
9. Select **Yes** in the Setup Configuration window. Both user HDP and master HDP will have been removed.

Power management

To reduce power consumption, the computer has three power management modes: screen blank, sleep (standby in Windows XP), and hibernation.

Screen blank mode

If the time set on the “Turn off monitor” timer in the operating system expires, the LCD backlight turns off.

To put the computer into screen blank mode, do as follows:

1. Press Fn+F3. A panel for selecting a power plan (in Windows XP, power scheme) appears.

2. Select **Power off display (keep current power plan)** (in Windows XP, **keep current power scheme**).

You can also put the computer into screen blank mode, press ThinkVantage button and use the ThinkVantage Productivity Center.

Note: If the computer is a Windows 7 model, it does not support ThinkVantage Productivity Center.

To end screen blank mode and resume normal operation, press any key.

Sleep (Standby) mode

When the computer enters sleep (standby) mode, the following events occur in addition to what occurs in screen blank mode:

- The LCD is powered off.
- The hard disk drive or the solid state drive is powered off.
- The CPU stops.

To enter sleep (standby) mode, press Fn+F4.

Note: You can change the action of the Fn+F4 key combination by changing the settings in Power Manager.

In certain circumstances, the computer goes into sleep (standby) mode automatically:

- If a “suspend time” has been set on the timer, and the user does not do any operation with the keyboard, the TrackPoint, the hard disk, the parallel connector, or the diskette drive within that time.
- If the battery indicator blinks orange, indicating that the battery power is low.

Note: Even if you do not set the low-battery alarm, the charge indicator notifies you when the battery is low, and then the computer enters the power-saving mode automatically.

To cause the computer to return from sleep (standby) mode and resume operation, do one of the following:

- Press the Fn key.
- Open the LCD cover.
- Turn on the power switch.

Also, in either of the following events, the computer automatically returns from sleep (standby) mode and resumes operation:

- The ring indicator (RI) is signaled by a serial device or a PC Card device. (*does not support the ring indicator (RI) resume by PC Card device.*)
- The time set on the resume timer elapses.

Note: The computer does not accept any input immediately after it enters sleep (standby) mode. Wait a few seconds before taking any action to reenter operation mode.

Hibernation mode

In hibernation mode, the following occurs:

- The system status, RAM, VRAM, and setup data are stored on the hard disk.
- The system is powered off.

Note: If the computer enters the hibernation mode while it is docked to the docking station, do not undock it before resuming normal operation. If you do undock it and then try to resume normal operation, you will get an error message, and you will have to restart the system.

To cause the computer to enter hibernation mode, do any of the following:

- Press the Fn+F12 keys.
- If you have defined one of the following actions as the event that causes the system to go into hibernation mode, perform that action.
 - Closing the lid.
 - Pressing the power button.
 - Pressing Fn+F4 keys.

Also, the computer goes into hibernation mode automatically in either of the following conditions:

- If a “hibernation time” has been set on the timer, and if the user does not do any operation with the keyboard, the TrackPoint, the hard disk drive, the parallel connector, or the diskette drive within that time.
- If the timer conditions are satisfied in suspend mode.

When the power is turned on, the computer returns from hibernation mode and resumes operation. The hibernation file in the boot record on the hard disk drive is read, and system status is restored from the hard disk drive.

Symptom-to-FRU index

This section contains following information:

- “Numeric error codes” on page 43
- “Error messages” on page 47
- “Beep symptoms” on page 48
- “No-beep symptoms” on page 49
- “LCD-related symptoms” on page 49
- “Intermittent problems” on page 49
- “Undetermined problems” on page 50

The symptom-to-FRU index in this section lists symptoms and errors and their possible causes. The most likely cause is listed first, in boldface type.

Note: Do the FRU replacement or other actions in the sequence shown in the column headed “FRU or action, in sequence.” If replacing a FRU does not solve the problem, put the original part back in the computer. Do not replace a nondefective FRU.

This index can also help you determine, during regular servicing, what FRUs are likely to need to be replaced next.

A numeric error is displayed for each error detected in POST or system operation. In the displays, **n** can be any number.

If no numeric code is displayed, check the narrative descriptions of symptoms. If the symptom is not described there, go to “Intermittent problems” on page 49.

Note: For a device not supported by diagnostic codes in the ThinkPad Notebooks, see the manual for that device.
--

Numeric error codes

Table 2. Numeric error codes

Symptom or error	FRU or action, in sequence
0175 Bad CRC1, stop POST task—The EEPROM checksum is not correct.	System board.
0176 System Security—The system has been tampered with.	<ol style="list-style-type: none"> 1. Run BIOS Setup Utility, and save the current setting by pressing F10. 2. System board.
0177 Bad SVP data, stop POST task—The checksum of the supervisor password in the EEPROM is not correct.	System board.
0182 Bad CRC2. Enter BIOS Setup and load Setup defaults.—The checksum of the CRS2 setting in the EEPROM is not correct.	<ol style="list-style-type: none"> 1. Run BIOS Setup Utility. Press F9, and Enter to load the default setting. Then save the current setting by pressing F10. 2. System board.
0185 Bad startup sequence settings. Enter BIOS Setup and load Setup defaults.	<ol style="list-style-type: none"> 1. Run BIOS Setup Utility. Press F9, and Enter to load the default setting. Then save the current setting by pressing F10.
0187 EAIA data access error—The access to EEPROM is failed.	System board.
0188 Invalid RFID Serialization Information Area.	System board.
0189 Invalid RFID configuration information area—The EEPROM checksum is not correct.	System board.
0190 Critical low-battery error	<ol style="list-style-type: none"> 1. Charge the battery pack. 2. Battery pack.
0191 System Security—Invalid Remote Change requested.	<ol style="list-style-type: none"> 1. Run BIOS Setup Utility, and then save current setting by pressing F10. 2. System board.
0192 System Security— Embedded Security hardware tamper detected.	System board.
0193 RF antenna has been removed	Enter the supervisor password.
0194 The computer has been carried through a security gate	Enter the supervisor password.
0195 Security hardware tamper detected	<ol style="list-style-type: none"> 1. Enter BIOS Setup Utility by entering supervisor password, and select Password → Security Chip → Clear Security Chip to clear this error. 2. Security chip. 3. System board.
0196 Security hardware removed	<ol style="list-style-type: none"> 1. Enter BIOS Setup Utility by entering supervisor password, and select Password → Security Chip → Clear Security Chip to clear this error. 2. Security chip. 3. System board.
0197 Invalid remote change requested.	The remote configuration for the security chip has failed. Confirm the operation and try again.

Table 2. Numeric error codes (continued)

Symptom or error	FRU or action, in sequence
0199 System Security— Security password retry count exceeded.	<ol style="list-style-type: none"> 1. Run BIOS Setup Utility, and then save the current setting by pressing F10. 2. System board.
01C8 Two or more modem devices are found. Remove all but one of them. Press <Esc> to continue.	<ol style="list-style-type: none"> 1. Remove either a Mini-PCI Card or a modem daughter card. Otherwise, press Esc to ignore the warning message. 2. System board.
01C9 Two or more Ethernet devices are found. Remove all but one of them. Press <Esc> to continue.	<ol style="list-style-type: none"> 1. Remove either a Mini PCI Ethernet card or an Ethernet daughter card. Otherwise, press Esc to ignore the warning message. 2. System board.
01C9 More than one Ethernet devices are found. Remove one of them. Press <Esc> to continue.	<ol style="list-style-type: none"> 1. Remove the Ethernet device that you installed; or press Esc to ignore the warning message. 2. System board.
01CA More than one Wireless LAN devices are found. Remove one of them.	<ol style="list-style-type: none"> 1. Remove the wireless LAN device that you installed. 2. System board.
0200 Hard disk error—The hard disk is not working.	<ol style="list-style-type: none"> 1. Reseat the hard disk drive. 2. Load Setup Defaults in BIOS Setup Utility. 3. Hard disk drive. 4. System board.
021x Keyboard error.	Run interactive tests of the keyboard and the auxiliary input device.
0220 Monitor type error—Monitor type does not match the one specified in CMOS.	Load Setup Defaults in BIOS Setup Utility.
0230 Shadow RAM error—Shadow RAM fails at offset nnnn.	System board.
0231 System RAM error—System RAM fails at offset nnnn.	<ol style="list-style-type: none"> 1. DIMM. 2. System board.
0232 Extended RAM error— Extended RAM fails at offset nnnn.	<ol style="list-style-type: none"> 1. DIMM. 2. System board.
0250 System battery error—System battery is dead.	<ol style="list-style-type: none"> 1. Charge the backup battery for more than 8 hours by connecting the ac power adapter. 2. Replace the backup battery and run BIOS Setup Utility to reset the time and date.
0251 System CMOS checksum bad— Default configuration used.	<ol style="list-style-type: none"> 1. Charge the backup battery for more than 8 hours by connecting the ac power adapter. 2. Replace the backup battery and run BIOS Setup Utility to reset the time and date.
0252 Password checksum bad— The password is cleared.	Reset the password by running BIOS Setup Utility.
0260 System timer error.	<ol style="list-style-type: none"> 1. Charge the backup battery for more than 8 hours by connecting the ac power adapter. 2. Replace the backup battery and run BIOS Setup Utility to reset the time and date. 3. System board.

Table 2. Numeric error codes (continued)

Symptom or error	FRU or action, in sequence
0270 Real-time clock error.	<ol style="list-style-type: none"> 1. Charge the backup battery for more than 8 hours by connecting the ac power adapter. 2. Replace the backup battery and run BIOS Setup Utility to reset the time and date. 3. System board.
0271 Date and time error—Neither the date nor the time is set in the computer.	Run BIOS Setup Utility to reset the time and date.
0280 Previous boot incomplete— Default configuration used.	<ol style="list-style-type: none"> 1. Load “Setup Default” in BIOS Setup Utility. 2. DIMM. 3. System board.
02B2 Incorrect drive A type.	<ol style="list-style-type: none"> 1. Diskette drive. 2. External FDD cable. 3. I/O card.
02D0 System cache error.	
02F0 CPU ID:xx Failed.	<ol style="list-style-type: none"> 1. CPU. 2. System board.
02F4 EISA CMOS not writable.	<ol style="list-style-type: none"> 1. Load Setup Defaults in BIOS Setup Utility. 2. Replace the backup battery. 3. System board.
02F5 DMA test failed.	<ol style="list-style-type: none"> 1. DIMM. 2. System board.
02F6 Software NMI failed	<ol style="list-style-type: none"> 1. DIMM. 2. System board.
02F7 Fail-safe timer NMI failed	<ol style="list-style-type: none"> 1. DIMM. 2. System board.
1801 Attached docking station is not supported	Shut down the computer and remove it from the docking station.
1802 Unauthorized network card is plugged in—Turn off and remove the miniPCI network card.	<ol style="list-style-type: none"> 1. Remove Mini PCI network card. 2. System board.
1803 Unauthorized daughter card is plugged in—Turn off and remove the daughter card.	<ol style="list-style-type: none"> 1. Remove the daughter card that you installed. 2. System board.
1804 Unauthorized WAN card is plugged in—Power off and remove the WAN card.	<ol style="list-style-type: none"> 1. Remove the WAN card that you installed. 2. System board.
1805 Unauthorized Wireless USB card is plugged in—Power off and remove the Wireless USB card.	<ol style="list-style-type: none"> 1. Remove the Wireless USB card that you installed. 2. System board.

Table 2. Numeric error codes (continued)

Symptom or error	FRU or action, in sequence
<p>1810 Hard disk partition layout error.</p>	<ol style="list-style-type: none"> 1. If the Access Predesktop Area has been previously disabled, then go to the BIOS Setup Utility by pressing F1 to open the BIOS Setup Utility. Select Security → Predesktop Area → Access Predesktop Area. Set this item to Disabled. Save and exit. 2. If the Access Predesktop Area has not been previously disabled, press Enter to load Access Predesktop Area. Then run RECOVER TO FACTORY CONTENTS in Access Predesktop Area. 3. If item 2 failed, press F3 in the Welcome screen in RECOVER TO FACTORY CONTENTS. Run FDISK, and then delete all partitions. Run RECOVER TO FACTORY CONTENTS in Access Predesktop Area again. 4. If item 3 failed, select CD-ROM boot in Startup in Access Predesktop Area. Boot from the Recovery CD and perform full recovery from it. 5. If item 4 failed, replace the hard disk drive.
<p>1820 More than one external fingerprint reader is attached. Power off and remove all but the reader that you set up within your main operating system.</p>	<p>Remove all but the reader that you set up for the authentication.</p>
<p>1830 Invalid memory configuration—Power off and install a memory module to Slot-0 or the lower slot.</p>	<p>Install DIMM in Slot-0, but not in Slot-1. Note: For the construction of the DIMM slot, see “1030 DIMM” on page 65.</p>
<p>2000 Hard Drive Active Protection sensor diagnostics failed.Press <Esc> to continue.Press <F1> to enter SETUP</p>	<ol style="list-style-type: none"> 1. Undock docking station or port replicator if it is attached to the ThinkPad Notebook. 2. Place the ThinkPad Notebook on a horizontal surface. Do not apply any physical shock to the computer. 3. Run Diagnostics → ThinkPad Devices → HDD Active Protection Test.
<p>2010 Warning: Your internal hard disk drive (HDD) may not function correctly on this system. Ensure that your HDD is supported on this system and that the latest HDD firmware is installed.</p>	<p>Inform the following information to the customer: If in the primary bay the customer is using a non-IBM or non-Lenovo hard disk drive (HDD), or an old generation IBM HDD which is not supported by this system, with the risk in mind, the customer can still use it by pressing ESC. If in the primary drive bay the customer is using a supported IBM/Lenovo HDD with an old firmware, the customer needs to update its firmware to the latest. The latest version is available at http://www.lenovo.com/support</p>
<p>201x The solid state drive you have installed has not passed qualification for use in this computer. Using this drive may cause compatibility issues and potential issues with data integrity, including data loss. Press <Esc> to continue.</p>	<p>Inform the following information to the customer: If the customer is using a non qualified SSD which is not supported by this system, with the risk in mind, the customer can still use it by pressing ESC. Location of the SSD is designated as below:</p> <p style="margin-left: 40px;">2010: HDD0 (in HDD slot-0) 2011: HDD1 (in HDD slot-1) 2012: Ultrabay™ with HDD adapter</p>
<p>2100 Initialization error on HDD0 (Main hard disk drive)</p>	<ol style="list-style-type: none"> 1. Reseat the hard disk drive. 2. Main hard disk drive. 3. System board.

Table 2. Numeric error codes (continued)

Symptom or error	FRU or action, in sequence
2102 Initialization error on HDD1 (Ultrabay hard disk drive)	<ol style="list-style-type: none"> 1. Reseat the hard disk drive. 2. Ultrabay hard disk drive. 3. System board.
2110 Read error on HDD0 (Main hard disk drive)	<ol style="list-style-type: none"> 1. Reseat the hard disk drive. 2. Main hard disk drive. 3. System board.
2112 Read error on HDD1 (Ultrabay hard disk drive)	<ol style="list-style-type: none"> 1. Reseat the hard disk drive. 2. Ultrabay hard disk drive. 3. System board.

Error messages

Table 3. Error messages

Symptom or error	FRU or action, in sequence
Device address conflict.	<ol style="list-style-type: none"> 1. Load “Setup Defaults” in the BIOS Setup Utility. 2. Backup battery. 3. System board.
Allocation error for device.	<ol style="list-style-type: none"> 1. Load “Setup Defaults” in the BIOS Setup Utility. 2. Backup battery. 3. System board.
Failing bits: nnnn.	<ol style="list-style-type: none"> 1. DIMM. 2. System board.
Invalid system configuration data.	<ol style="list-style-type: none"> 1. DIMM. 2. System board.
I/O device IRQ conflict.	<ol style="list-style-type: none"> 1. Load “Setup Defaults” in the BIOS Setup Utility. 2. Backup battery. 3. System board.
Hibernation error.	<ol style="list-style-type: none"> 1. Restore the system configuration to what it was before the computer entered hibernation mode. 2. If memory size has been changed, re-create the hibernation file.
Fan error.	<ol style="list-style-type: none"> 1. Fan. 2. Thermal grease. 3. System board.
Thermal sensing error.	System board.

Table 3. Error messages (continued)

Symptom or error	FRU or action, in sequence
Cannot boot from any device.	<p>Check the status of device which you want to boot from.</p> <p>Device not found.</p> <ol style="list-style-type: none"> The device you want to boot from. System board. <p>Device Error.</p> <ol style="list-style-type: none"> The device you want to boot from. System board. <p>No valid operating system.</p> <ol style="list-style-type: none"> Check that the operating system has no failure and is installed correctly. Reinstall the operation system. <p>Excluded from boot order.</p> <ul style="list-style-type: none"> Enter the BIOS Setup Utility and add the device in boot order.

Beep symptoms

Table 4. Beep symptoms

Symptom or error	FRU or action, in sequence
One beep and a blank, unreadable, or flashing LCD.	<ol style="list-style-type: none"> Reseat the LCD connector. LCD assembly. External CRT. System board.
One long and two short beeps, and a blank or unreadable LCD.	<ol style="list-style-type: none"> System board. LCD assembly. DIMM.
Two short beeps with error codes.	POST error. See “Numeric error codes” on page 43.
Two short beeps and a blank screen.	<ol style="list-style-type: none"> System board. DIMM.
Two or more beeps, or a continuous beep. Operating system starts successfully.	If a mini-PCI Ethernet card is installed, confirm that Alert On LAN 2 in BIOS Setup Utility is disabled .
Three short beeps, pause, three more short beeps, and one short beep.	<ol style="list-style-type: none"> DIMM. System board.
One short beep, pause, three short beeps, pause, three more short beeps, and one short beep.	
Only the cursor appears.	Reinstall the operating system.
Four cycles of four short beeps and a blank screen.	System board (security chip)
Five short beeps and a blank screen.	System board

No-beep symptoms

Table 5. No-beep symptoms

Symptom or error	FRU or action, in sequence
No beep, power-on indicator on, LCD blank, and no POST.	<ol style="list-style-type: none"> 1. Make sure that every connector is connected tightly and correctly. 2. DIMM. 3. System board.
No beep, power-on indicator on, and LCD blank during POST.	<ol style="list-style-type: none"> 1. Reseat DIMM. 2. System board.
The power-on password prompt appears.	A power-on password or a supervisor password is set. Type the password and press Enter .
The hard-disk password prompt appears.	A hard-disk password is set. Type the password and press Enter .

LCD-related symptoms

<p>Important: The TFT LCD for the notebook computer contains many thin-film transistors (TFTs). The presence of a small number of dots that are missing, discolored, or always lighted is characteristic of TFT LCD technology, but excessive pixel problems can cause viewing concerns.</p> <p>If the LCD you are servicing has two or less visible defective pixels, it should not be considered faulty. However, if the LCD has three or more visible defective pixels, it will be deemed as defective by Lenovo and it should be replaced.</p> <p>Notes:</p> <ul style="list-style-type: none"> • This policy applies to all ThinkPad Notebooks purchased on 1 January, 2008 or later. • Lenovo will not provide replacement if the LCD is within specification as we cannot guarantee that any replacement LCD will have zero pixel defects. • One pixel consists of R, G, B sub-pixels.
--

Table 6. LCD-related symptoms

Symptom or error	FRU or action, in sequence
No beep, power-on indicator on, and a blank LCD during POST.	System board.
<ul style="list-style-type: none"> • LCD backlight not working. • LCD too dark. • LCD brightness cannot be adjusted. • LCD contrast cannot be adjusted. 	<ol style="list-style-type: none"> 1. Reseat the LCD connectors. 2. LCD assembly. 3. System board.
<ul style="list-style-type: none"> • LCD screen unreadable. • Characters missing pixels. • Screen abnormal. • Wrong color displayed. 	<ol style="list-style-type: none"> 1. See important note for “LCD-related symptoms.” 2. Reseat all LCD connectors. 3. LCD assembly. 4. System board.
Horizontal or vertical lines displayed on LCD.	LCD assembly.

Intermittent problems

Intermittent system hang problems can be due to a variety of causes that have nothing to do with a hardware defect, such as cosmic radiation, electrostatic discharge, or software errors. FRU replacement should be considered only when a problem recurs.

When analyzing an intermittent problem, do the following:

1. Run the diagnostic test for the system board in loop mode **at least 10 times**.

2. If no error is detected, do **not** replace any FRUs.
3. If any error is detected, replace the FRU shown by the FRU code. Rerun the test to verify that no more errors exist.

Undetermined problems

If the diagnostic tests did not identify the adapter or device that has failed, if wrong devices are installed, or if the system simply is not operating, follow these procedures to isolate the failing FRU (do not isolate FRUs that have no defects).

Verify that all attached devices are supported by the computer.

Verify that the power supply being used at the time of the failure is operating correctly. (See “Power system checkout” on page 33.)

1. Turn off the computer.
2. Visually check each FRU for damage. Replace any damaged FRU.
3. Remove or disconnect all of the following devices:
 - a. Non-ThinkPad devices
 - b. Devices attached to the docking station or the port replicator
 - c. Printer, mouse, and other external devices
 - d. Battery pack
 - e. Hard disk drive
 - f. External diskette drive or optical drive
 - g. DIMM
 - h. Optical disk or diskette in the internal drive
 - i. PC Cards
4. Turn on the computer.
5. Determine whether the problem has been solved.
6. If the problem does not recur, reconnect the removed devices one at a time until you find the failing FRU.
7. If the problem remains, replace the following FRUs one at a time (do not replace a nondefective FRU):
 - a. System board
 - b. LCD assembly

Chapter 5. Status indicators

This chapter presents the system status indicators that show the status of the computer.

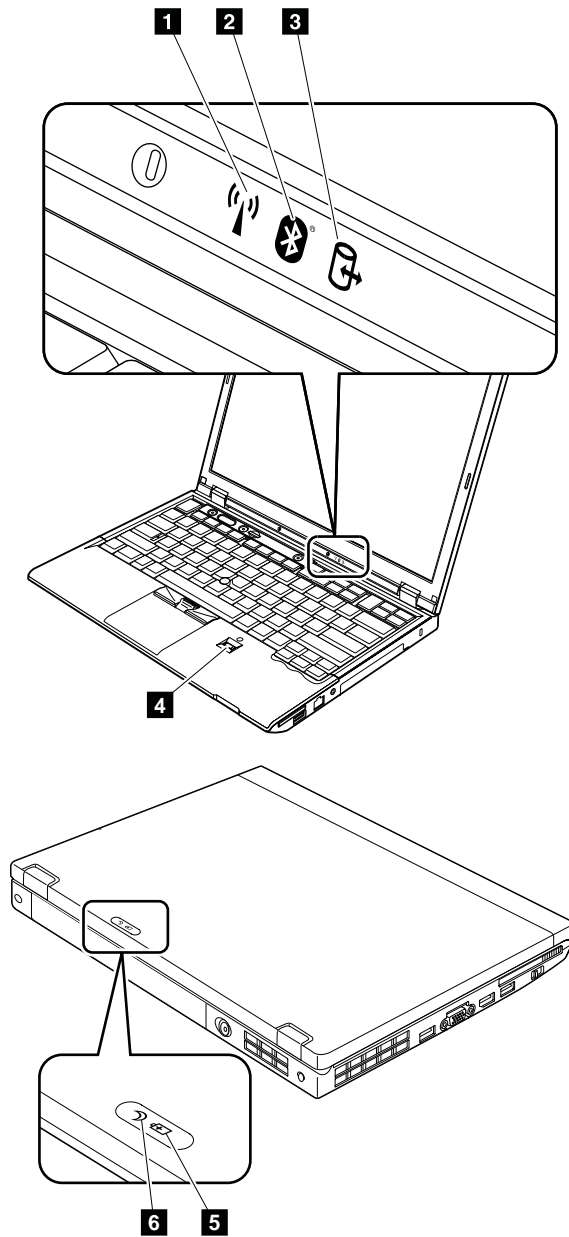







Table 7. Status indicators

Indicator	Meaning
<p>1 Wireless LAN status</p> 	<p>Green: The wireless LAN feature is on, and the radio link is ready for use, or the data is being transmitted.</p> <p>Blinking green: Data is being transmitted (for some models).</p>
<p>2 Wireless PAN status</p> 	<p>Green: Wireless PAN (<i>Bluetooth</i> wireless or Wireless USB) is operational. This indicator is on when Wireless PAN is on and not in suspend mode, or the data is being transmitted.</p> <p>Blinking green: Data is being transmitted (for some models).</p>
<p>3 Drive in use</p> 	<p>Green: Data is being read from or written to the hard disk drive, the diskette drive, or the drive in the Serial Ultrabay Slim device. When this indicator is on, do not put the computer into sleep (standby) mode or turn off the computer.</p> <p>Note: Do not move the system while the green drive-in-use light is on. Sudden physical shock could cause drive errors.</p>
<p>4 Fingerprint reader status</p> 	<p>Green: The fingerprint reader is ready to swipe.</p> <p>Blinking green: The fingerprint is being authenticated or has been authenticated.</p> <p>Blinking amber: The fingerprint could not be authenticated.</p>
<p>5 Battery status</p> 	<p>Green: The battery is being charged when its charge level is between 80% and 100%. Or the battery is being discharged when its charge level is between 0% and 80%.</p> <p>Blinking green: The battery charge level is between 20% and 80%, and the battery is being charged.</p> <p>Orange: The battery charge level is between 5% and 20%, and the battery is being discharged.</p> <p>Blinking orange (slow): The battery charge level is between 5% and 20%, and the battery is being charged.</p> <p>Blinking orange (rapid): The battery charge level is between 0% and 5%, and the battery is being charged.</p>
<p>6 Sleep (standby) status</p> 	<p>Green: The computer is in sleep (standby) mode.</p> <p>Blinking green: The computer is entering sleep (standby) mode or hibernation mode, or is resuming normal operation.</p>

Chapter 6. Fn key combinations

The following table shows the function of each combination of Fn with a function key.

Table 8. Fn key combinations

Key combination	Description
Fn+F1	Reserved.
Fn+F2	Lock the computer.
Fn+F3	<p>Select a power plan (in Windows XP, power scheme) that has been created by Power Manager, or adjust the power level by using the slider control. When you press this combination, a panel for selecting a power plan (power scheme) appears.</p> <p>Notes:</p> <ol style="list-style-type: none">1. To use the Fn+F3 key combination, you must have the ThinkPad PM device driver installed on the computer.2. If you have logged on with an administrator user ID, and you press Fn+F3, the panel for selecting a power plan (power scheme) appears. If you have logged on with another user ID, and you press Fn+F3, the panel does not appear.3. You cannot turn off the computer display by pressing Fn+F3.
Fn+F4	<p>Put the computer in sleep (standby) mode. To return to normal operation, press the Fn key only, without pressing a function key.</p> <p>Notes:</p> <ol style="list-style-type: none">1. To use the Fn+F4 key combination, you must have the ThinkPad PM device driver installed on the computer.2. If you want to use the combination to put the computer into hibernation mode or do-nothing mode (in Windows XP, shut the computer down or show the panel for turning off the computer), change the settings in the Power Manager.
Fn+F5	<p>Enable or disable the built-in wireless networking features and the <i>Bluetooth</i> features. If you press Fn+F5, a list of wireless features is displayed. You can quickly change the power state of each feature in the list.</p> <p>Notes: If you want to use Fn+F5 to enable the wireless feature, the following device drivers must be installed on the computer beforehand:</p> <ul style="list-style-type: none">• ThinkPad Power Management driver• OnScreen Display Utility• Wireless device drivers
Fn+F6	Change the camera and audio settings.
Fn+F7	<p>Apply a presentation scheme directly, with no need to start Presentation Director.</p> <p>To disable this function and use the Fn+F7 key combination for switching a display output location, start Presentation Director, and change the settings.</p> <p>Note: If the computer is a Windows 7 model, it does not support presentation schemes, but the Fn+F7 combination is available for switching a display output location.</p>

Table 8. Fn key combinations (continued)

Key combination	Description
	<p>For Windows 7: Switch a display output location</p> <ul style="list-style-type: none"> • Computer display only (LCD) • Computer display and external monitor (same image) • Computer display and external monitor (extended desktop) • External monitor only <p>Note: To switch between the computer display and an external monitor, the Win+P key combination is also available.</p> <p>For Windows Vista and Windows XP: Switch a display output location</p> <ul style="list-style-type: none"> • External monitor • Computer display (LCD) and external monitor • Computer display (LCD) <p>Notes:</p> <ol style="list-style-type: none"> 1. This function is not supported if different desktop images are displayed on the computer display and the external monitor (the Extend desktop function). 2. This function does not work while a DVD movie or a video clip is playing. <p>To enable this function, start Presentation Director, and change the Fn+F7 settings.</p> <p>Note: Multiple users can log on to a single operating system by using different user IDs. Each user needs to change the settings.</p>
Fn+F8	Change the settings of the input device.
Fn+F9	<p>Open the ThinkPad EasyEject Utility screen. Buttons for the following choices are displayed:</p> <ul style="list-style-type: none"> • Eject ThinkPad PC from UltraBase: This button is displayed only if the ThinkPad computer has been attached to a ThinkPad X220 UltraBase. The computer can be detached from the ThinkPad X220 UltraBase. • Run EasyEject Actions: This button is used to select, stop, or remove external devices connected to the ThinkPad computer. • Configure EasyEject Actions: Opens the ThinkPad EasyEject Utility main window. • Fn+F9 Settings: Configures the settings for the Fn+F9 function. <p>Note: If the computer is a Windows 7 model, it does not support the EasyEject Utility function.</p>
Fn+F10	Reserved.
Fn+F11	Reserved.
Fn+F12	<p>Put the computer into hibernation mode. To return to normal operation, press the power button for less than four seconds.</p> <p>Note: To use Fn+F12 for hibernation, you must have the ThinkPad PM device driver installed on the computer.</p>
Fn+PgUp	<p>Turn the ThinkLight® on or off.</p> <p>Note: This function is supported only on the ThinkPad computers that have the ThinkLight. The on or off status of the ThinkLight is shown on the screen for a few seconds when you press Fn+PgUp.</p>
Fn+Home	The computer display becomes brighter.
Fn+End	The computer display becomes dimmer.
Fn+Spacebar	Enable the FullScreen Magnifier function.
Fn+PrtSc	Has the same function as the SysRq key.
Fn+ScrLk	Enable or disable the numeric keypad.

Table 8. Fn key combinations (continued)

Key combination	Description
Fn+Pause	Has the same function as the Break key.
Fn+cursor keys	These key combinations work with Windows Media Player. Fn+down arrow key works for the Play or Pause button, Fn+up arrow key for the Stop button, Fn+right arrow key for the Next Track button, and Fn+left arrow key for the Previous Track button.

Chapter 7. FRU replacement notices

External CRU statement to customers:

Some problems with your product can be resolved with a replacement part you can install yourself, called a “Customer Replaceable Unit” or “CRU.” Some CRUs are designated as Self-service CRUs and others are designated as Optional-service CRUs. *Installation of Self-service CRUs is your responsibility; you may request that Lenovo installs an Optional-service CRU according to the warranty service for your product.* Where you are installing the CRU, Lenovo will ship the CRU to you. CRU information and replacement instructions are shipped with your product and are available from Lenovo at any time upon request. You may find a list of CRUs in the publications that ship with your product or at <http://www.lenovo.com/CRUs>. You may be required to return the defective part that is replaced by the CRU. When return is required: (1) return instructions, a prepaid shipping label, and a container will be included with the replacement CRU; and (2) you may be charged for the replacement CRU if Lenovo does not receive the defective part within thirty (30) days of your receipt of the replacement CRU. See your Lenovo Limited Warranty documentation for full details.

This chapter presents notices related to removing and replacing parts. Read this chapter carefully before replacing any FRU.

Screw notices

Loose screws can cause a reliability problem. In the ThinkPad Notebook, this problem is addressed with special nylon-coated screws that have the following characteristics:

- They maintain tight connections.
- They do not easily come loose, even with shock or vibration.
- They are harder to tighten.
- Each one should be used only once.

Do the following when you service this machine:

- Keep the screw kit (for the P/N, see “Miscellaneous parts” on page 125) in your tool bag.
- Always use new screws.
- Use a torque screwdriver if you have one.

Tighten screws as follows:

- **Plastic to plastic**

Turn an additional **90 degrees** after the screw head touches the surface of the plastic part:

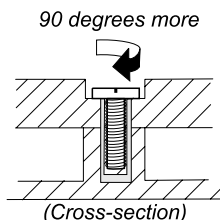

- **Logic card to plastic**

Turn an additional **180 degrees** after the screw head touches the surface of the logic card:

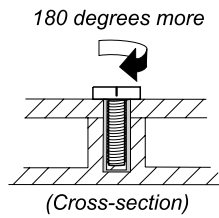

- **Torque driver**

If you have a torque driver, refer to the “Torque” column for each step.

- Make sure that you use the correct screw. If you have a torque screwdriver, tighten all screws firmly to the torque shown in the table. **Never use a screw that you removed. Use a new one. Make sure that all of the screws are tightened firmly.**
- Ensure torque screw drivers are calibrated correctly following country specifications.

Retaining serial numbers

This section includes the following descriptions:

- “Restoring the serial number of the system unit” on page 58
- “Retaining the UUID” on page 59
- “Reading or writing the ECA information” on page 59

Restoring the serial number of the system unit

When the computer was manufactured, the EEPROM on the system board was loaded with the serial numbers of the system and all major components. These numbers need to remain the same throughout the life of the computer.

If you replace the system board, you must restore the serial number of the system unit to its original value.

Before replacing the system board, save the original serial number by doing the following:

1. Install the LENOVO ThinkPad Hardware Maintenance Diskette Version 1.76 or later, and restart the computer.
2. From the main menu, select **1. Set System Identification**.
3. Select **2. Read S/N data from EEPROM**.

The serial number of each device in your computer is displayed; the serial number of the system unit is listed as follows:

- 20: Serial number

Write down that number.

Note: The serial number of the system unit is also written on the label attached to the bottom of the computer.

After you have replaced the system board, restore the serial number by doing the following:

1. Install the LENOVO ThinkPad Hardware Maintenance Diskette Version 1.76 or later and restart the computer.
2. From the main menu, select **1. Set System Identification**.
3. Select **1. Add S/N data from EEPROM**. Follow the instructions on the screen.

If the MTM and Product ID numbers differ from each other on the rear label, use what is shown for the Product ID field. See example below:

MTM on rear label:

TTTT-CTO S/N SSSSSSS

Product ID on rear label:

TTTT-MMM (Use this number when setting Serial Number)

In the example, the Serial Number to be input is "1STTTTMMMSSSSSSSS".

Retaining the UUID

The Universally Unique Identifier (UUID) is a 128-bit number uniquely assigned to your computer at production and stored in the EEPROM of your system board. The algorithm that generates the number is designed to provide unique IDs until the year A.D. 3400. No two computers in the world have the same number.

When you replace the system board, you must set the UUID on the new system board as follows:

1. Install the LENOVO ThinkPad Hardware Maintenance Diskette Version 1.76 or later, and restart the computer.
2. From the main menu, select **4. Assign UUID**. A new UUID is created and written. If a valid UUID already exists, it is not overwritten.

Reading or writing the ECA information

Information on Engineering Change Announcements (ECA) are stored in the EEPROM of the system board. The electronic storage of this information simplifies the procedure to check if the ECA has been previously applied to a machine. The machine does not need to be disassembled to check for the ECA application.

To check what ECAs have been previously applied to the machine, use the ECA Information Read/Write function on the LENOVO ThinkPad Hardware Maintenance Diskette Version 1.76 or later.

1. Insert the LENOVO ThinkPad Hardware Maintenance Diskette Version 1.76 or later, and restart the computer.
2. From the main menu, select **6. Set ECA Information**.
3. To read ECA information, select **2. Read ECA/rework number from EEPROM** and follow the instruction.
4. To read box build date, select **5. Read box build date from EEPROM**, and follow the instruction on the screen.

After an ECA has been applied to the machine, the EEPROM must be updated to reflect the ECA's application. Use the LENOVO ThinkPad Hardware Maintenance Diskette Version 1.76 or later to update the EEPROM.

Note: Only the ECA number is stored in the EEPROM. The machine type of the ECA is assumed be the same as the machine type of the machine that had the ECA applied to it.

1. Insert the LENOVO ThinkPad Hardware Maintenance Diskette Version 1.76 or later, and restart the computer.
2. From the main menu, select **6. Set ECA Information**.
3. To write ECA information, select **1. Write ECA/rework number from EEPROM**, and follow the instruction.
4. To write box build date, select **4. Write box build date from EEPROM**, and follow the instruction on the screen.

If the system board is being replaced, try to read the ECA information from the old system board and transfer the information to the new system. If the system board is inoperable, this will not be possible.

Chapter 8. Removing and replacing a FRU

External CRU statement to customers:

Some problems with your product can be resolved with a replacement part you can install yourself, called a “Customer Replaceable Unit” or “CRU.” Some CRUs are designated as Self-service CRUs and others are designated as Optional-service CRUs. *Installation of Self-service CRUs is your responsibility; you may request that Lenovo installs an Optional-service CRU according to the warranty service for your product.* Where you are installing the CRU, Lenovo will ship the CRU to you. CRU information and replacement instructions are shipped with your product and are available from Lenovo at any time upon request. You may find a list of CRUs in the publications that ship with your product or at <http://www.lenovo.com/CRUs>. You may be required to return the defective part that is replaced by the CRU. When return is required: (1) return instructions, a prepaid shipping label, and a container will be included with the replacement CRU; and (2) you may be charged for the replacement CRU if Lenovo does not receive the defective part within thirty (30) days of your receipt of the replacement CRU. See your Lenovo Limited Warranty documentation for full details.

This chapter presents directions and drawings for use in removing and replacing a FRU. Be sure to observe the following general rules:

1. Do not try to service any computer unless you have been trained and certified. An untrained person runs the risk of damaging parts.
2. Before replacing any FRU, review Chapter 7 “FRU replacement notices” on page 57.
3. Begin by removing any FRUs that have to be removed before replacing the failing FRU. Any such FRUs are listed at the top of each FRU replacement page. Remove them in the order in which they are listed.
4. Follow the correct sequence in the steps for removing a FRU, as given in the drawings by the numbers in square callouts.
5. When turning a screw to replace a FRU, turn it in the direction as given by the arrow in the drawing.
6. When removing a FRU, move it in the direction as given by the arrow in the drawing.
7. To put the new FRU in place, reverse the removal procedure and follow any notes that pertain to replacement. For information about connecting and arranging internal cables, see Chapter 9 “Locations” on page 99.
8. When replacing a FRU, use the correct screw(s) as shown in the procedures.



Before removing any FRU, turn off the computer, unplug all power cords from electrical outlets, remove the battery pack, and then disconnect any interconnecting cables.

Attention: After replacing a FRU, do not turn on the computer until you have made sure that all screws, springs, and other small parts are in place and none are loose inside the computer. Verify this by shaking the computer gently and listening for rattling sounds. Metallic parts or metal flakes can cause electrical short circuits.

Attention: The system board is sensitive to, and can be damaged by, electrostatic discharge. Before touching it, establish personal grounding by touching a ground point with one hand or by using an electrostatic discharge (ESD) strap (P/N 6405959).

Before servicing ThinkPad X220 and X220i models

Removing the SIM card:

Some models of the ThinkPad X220 and X220i you are servicing might have the SIM card that the customer has been installed.

If the computer you are servicing has the SIM card, remove it before you start the servicing.

To remove the SIM card, you need to remove the battery pack first. (See “1010 Battery pack” on page 63.)

After you finish the servicing, make sure that you insert the card back into the slot firmly.

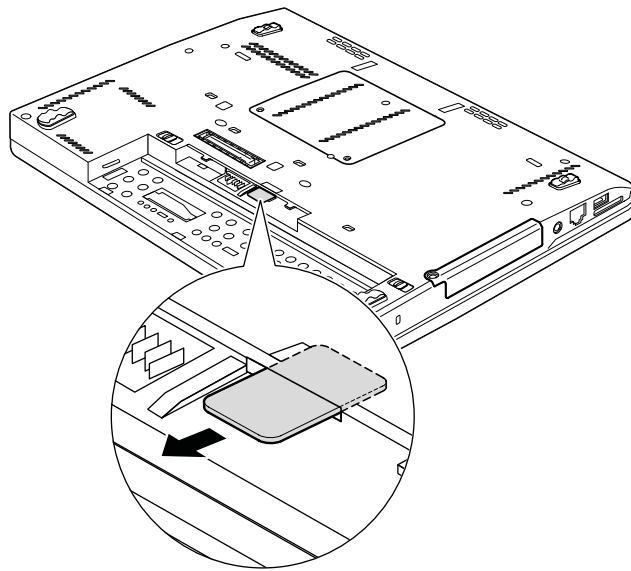

Notice on disconnecting a cable from a flip-lock ZIF connector:

Some cables used in ThinkPad X220 and X220i models are connected to flip-lock ZIF connectors.

When disconnecting a cable from a flip-lock ZIF connector, do as shown in the following figure.

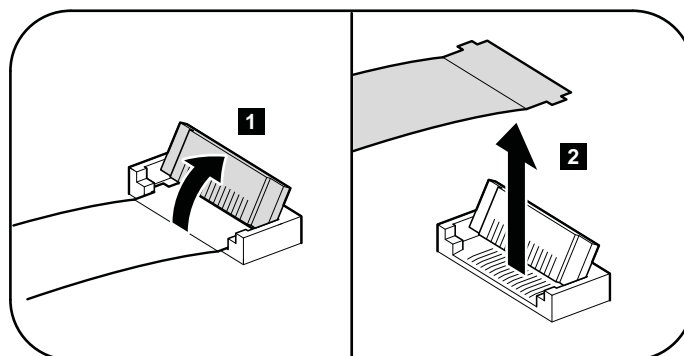

1010 Battery pack

Important notice for replacing a battery pack:

Lenovo ThinkVantage Toolbox (in Windows 7) has an automatic battery diagnostic that determines if the battery pack is defective. A battery pack FRU should not be replaced unless this diagnostic shows that the battery is defective.

The only exception to this is if the battery pack is physically damaged or a customer is reporting a possible safety issue.

If Lenovo ThinkVantage Toolbox is not installed in the computer, the customer should download this program before a non-physically damaged battery pack is replaced. Note that a physically damaged battery pack is a non-warranty replacement part.

Table 9. Removal steps of battery pack



Use only the battery specified in the parts list for your computer. Any other battery could ignite or explode.

Slide the left battery latch to the unlocked position **1**, and then hold the right battery latch to the unlocked position until you remove the battery **2**.

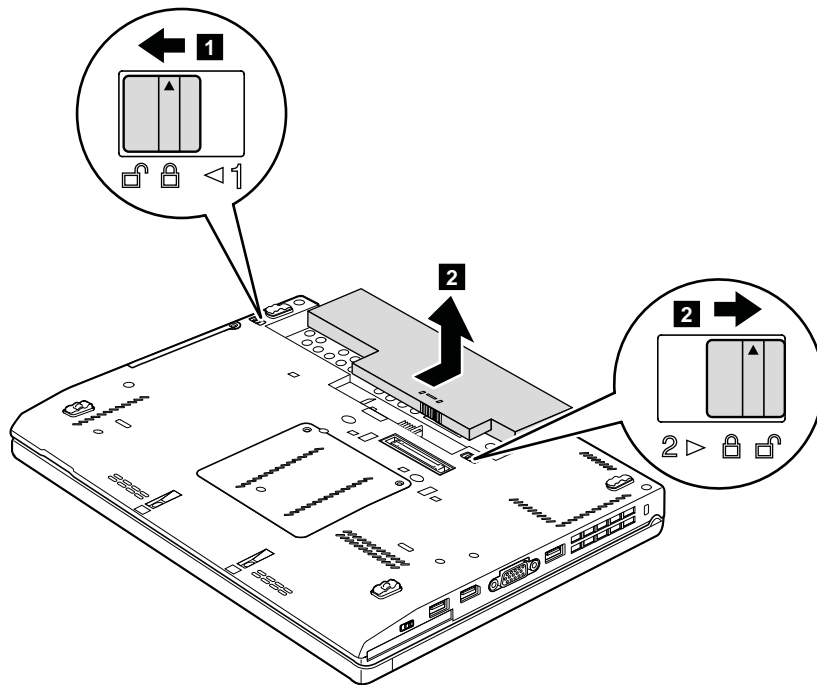

When installing:

Install the battery pack along the slide rails of the slot. Make sure that the left battery release lever is in the locked position.

1020 Hard disk drive (HDD) and solid state drive (SSD)

For access, remove this FRU:

- “1010 Battery pack” on page 63

Attention:

- Do not drop the hard disk drive or apply any physical shock to it. The hard disk drive is sensitive to physical shock. Improper handling can cause damage and permanent loss of data.
- Before removing the drive, have the user make a backup copy of all the information on it if possible.
- Never remove the drive while the system is operating or is in suspend mode.

Table 10. Removal steps of hard disk drive and solid state drive

Note: Loosen the screw **1**.

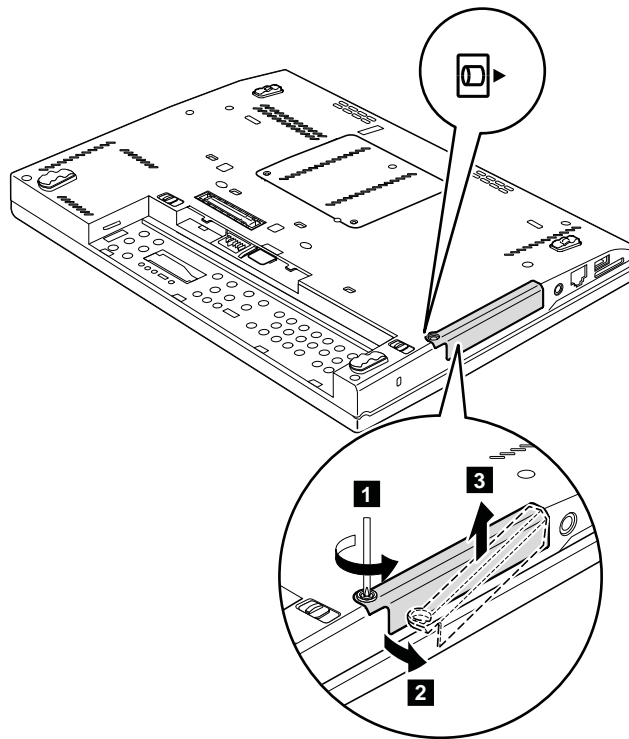

Step	Screw (quantity)	Color	Torque
1	Hard disk drive screw, M3 × 3 mm, wafer-head, nylon-coated (1)	Black	0.392 Nm (4 kgfcm)

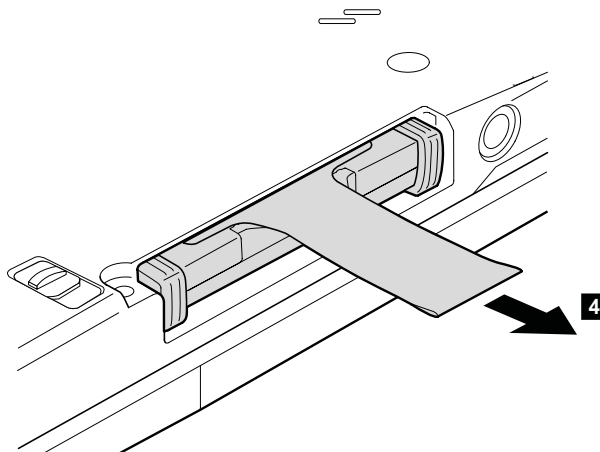
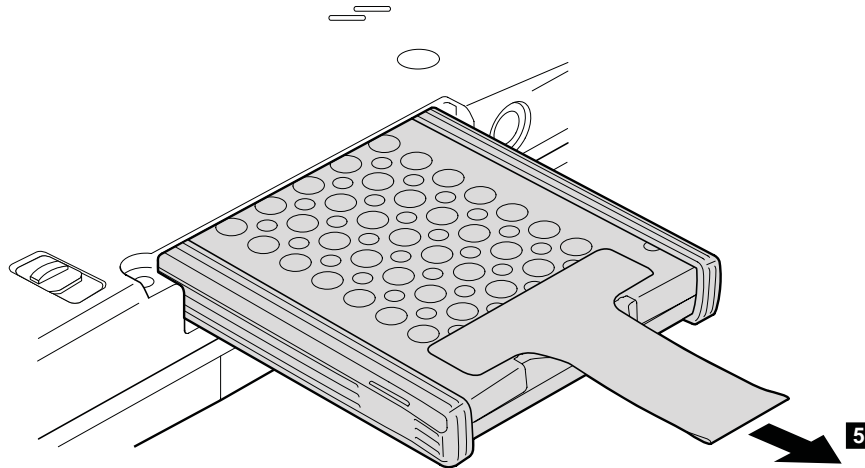
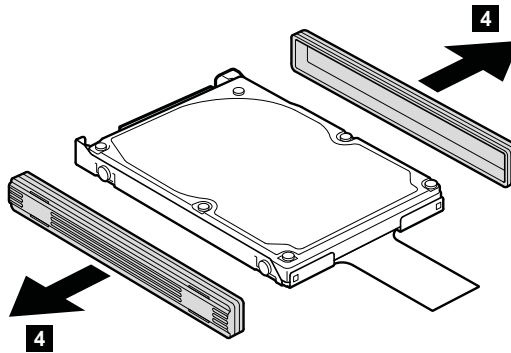

Table 10. Removal steps of hard disk drive and solid state drive (continued)



HDD and HDD rubber rails:



SSD and SSD spacers:

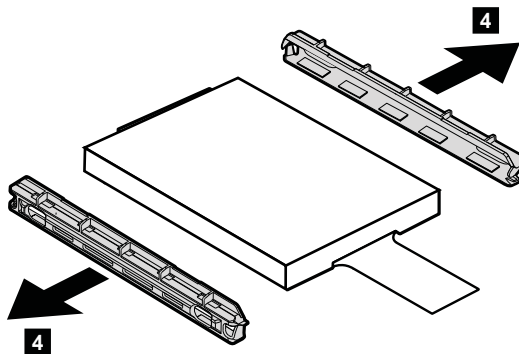

When installing:

Rubber rails on the hard disk drive or spacers on the solid state drive must be attached to the replacement drive. Otherwise the drive cannot be installed properly.

1030 DIMM

For access, remove this FRU:

- “1010 Battery pack” on page 63

Table 11. Removal steps of DIMM

Remove the DIMM slot cover as shown in the following figure.

Loosen the screws **1**.

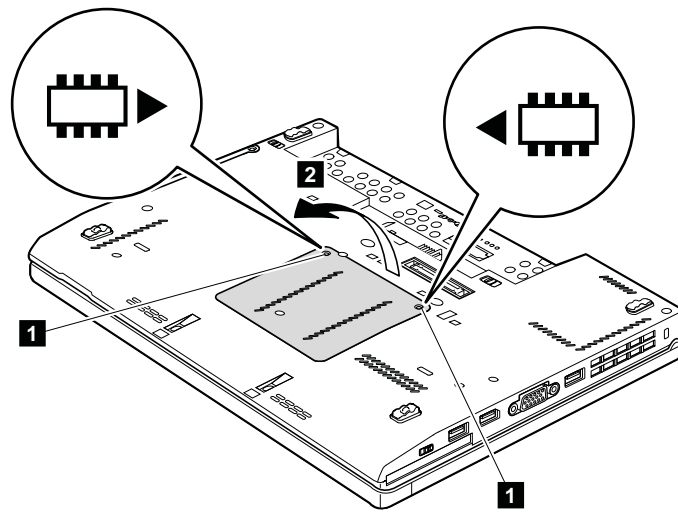

If only one DIMM is used on the computer you are servicing, the card must be installed in SLOT-0 **a**, but not in SLOT-1 **b**.

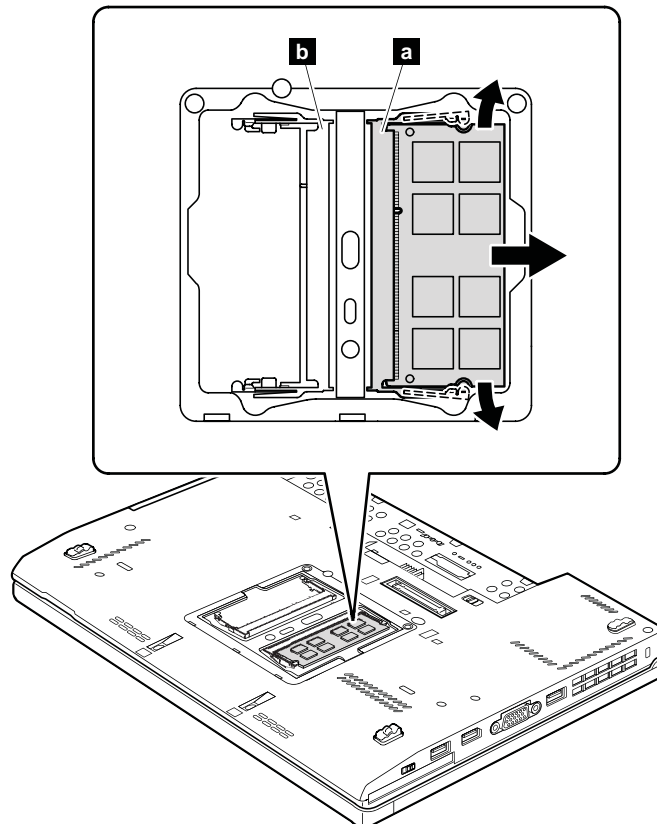

When installing:

Insert the notched end of the DIMM into the socket. Press the DIMM firmly, and pivot it until it snaps into place. Make sure that it is firmly installed in the slot and does not move easily.

1040 Keyboard

For access, remove this FRU:

- “1010 Battery pack” on page 63

Table 12. Removal steps of keyboard

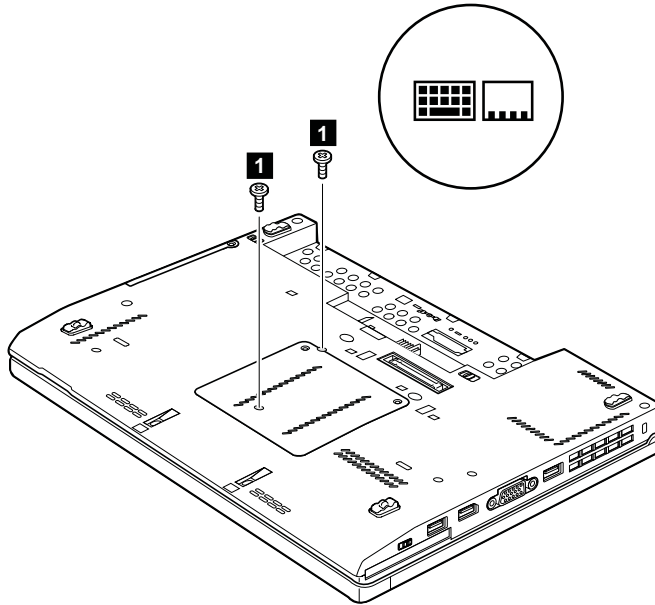

Step	Icon	Screw (quantity)	Color	Torque
1		M2 × 5 mm, wafer-head, nylon-coated (2)	Black	0.181 Nm (1.85 kgfcm)

Slightly press the keyboard and slide it a little bit forward, in the direction shown by arrow **2**, to detach the front edge of the keyboard from the frame. Then, lift up the keyboard in the direction shown by arrow **3**.

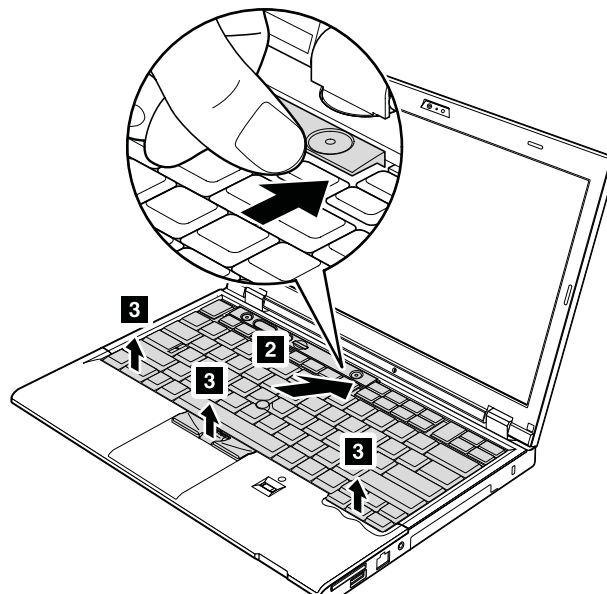
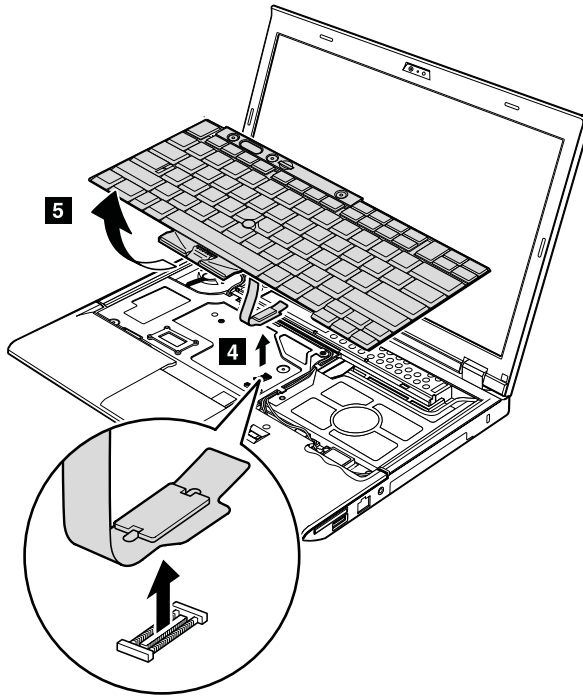

Table 12. Removal steps of keyboard (continued)

Lift the keyboard a little in the direction shown by arrow **5**, and then detach the connector **4**.



When installing:

1. Attach the keyboard connector firmly.
2. Make sure that the keyboard edge is under the frame as shown in the following figure. Then press the keys to latch the keyboard firmly in place.

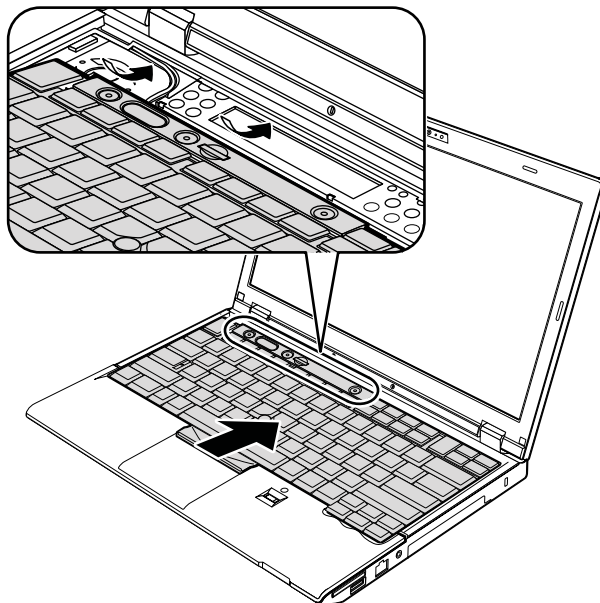
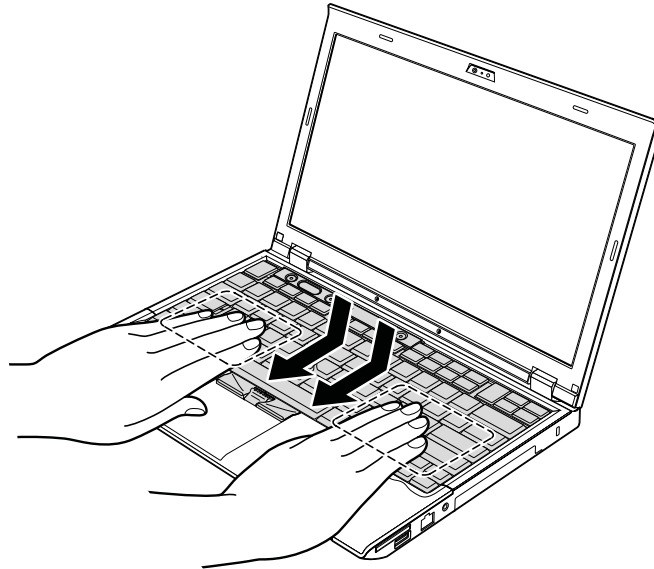

Table 12. Removal steps of keyboard (continued)

3. Gently press the keys with your palms and slightly slide the keyboard toward you until it snaps into position.



4. Secure the keyboard by tightening the screws from the bottom side of the computer.

1050 Palm rest or palm rest with a fingerprint reader

For access, remove these FRUs in order:

- “1010 Battery pack” on page 63
- “1040 Keyboard” on page 67

Note: In models with a fingerprint reader, the sensor is attached to the palm rest FRU. If the fingerprint reader has any defects, you can replace it by the procedures given in this section, which are the same for a palm rest with or without a fingerprint reader.

Table 13. Removal steps of palm rest

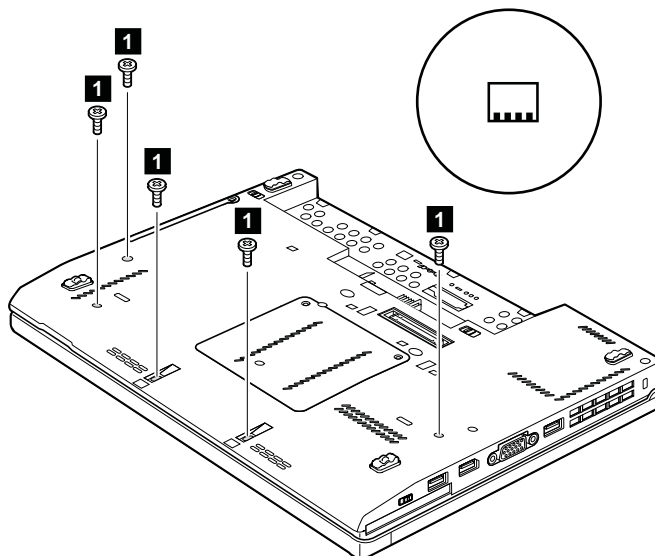



Table 13. Removal steps of palm rest (continued)

Step	Icon	Screw (quantity)	Color	Torque
1		M2 × 5 mm, wafer-head, nylon-coated (5)	Black	0.181 Nm (1.85 kgfcm)

Step **2** is only for models with a fingerprint reader. For models without a fingerprint reader, skip step **2**.

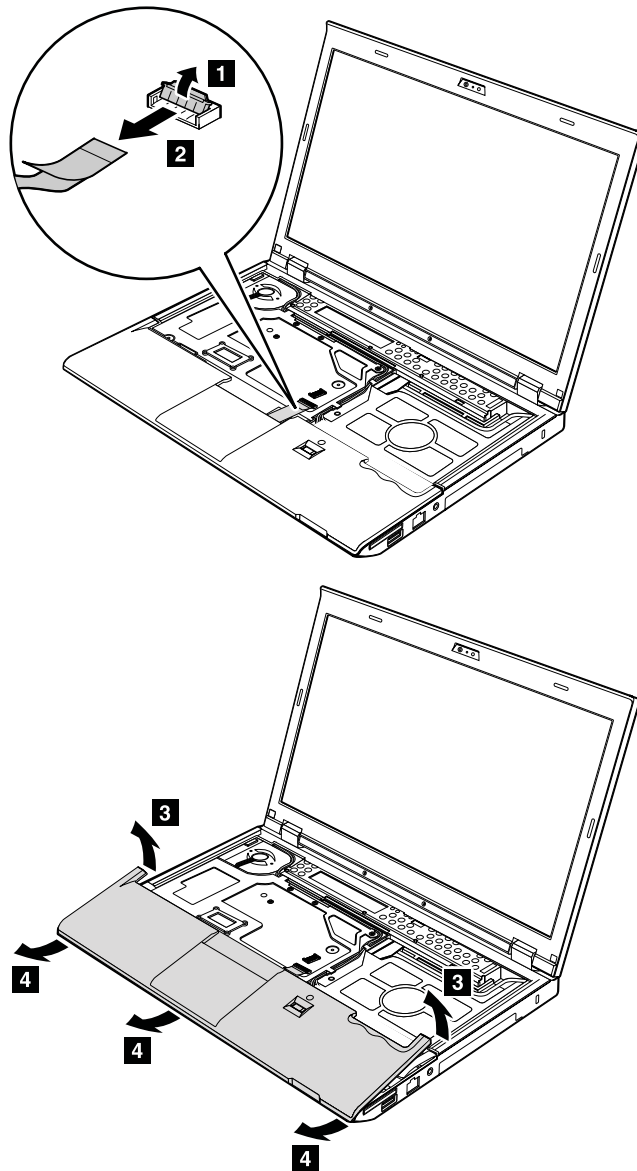
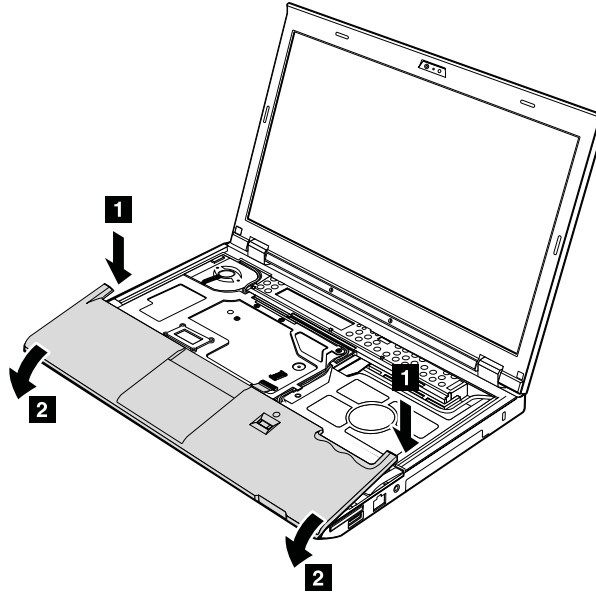

Table 13. Removal steps of palm rest (continued)

When installing:

1. In models with a fingerprint reader, attach the fingerprint reader connector firmly to the system board.
2. Press the left and right top edges of the palm rest to fit it into place.
3. Push the front side of the palm rest until it clicks into place.
4. Close the LCD cover and turn the computer over. Then fasten the five screws to secure the palm rest.



1060 PCI Express Mini Card for wireless LAN/WiMAX

For access, remove these FRUs in order:

- “1010 Battery pack” on page 63
- “1040 Keyboard” on page 67
- “1050 Palm rest or palm rest with a fingerprint reader” on page 69

Table 14. Removal steps of PCI Express Mini Card for wireless LAN/WiMAX

In step **1**, unplug the jacks by using the removal tool antenna RF connector (P/N: 08K7159) or pick the connectors with your fingers and gently unplug them in the direction of the arrow.

Note: Some models might have three antenna cables.

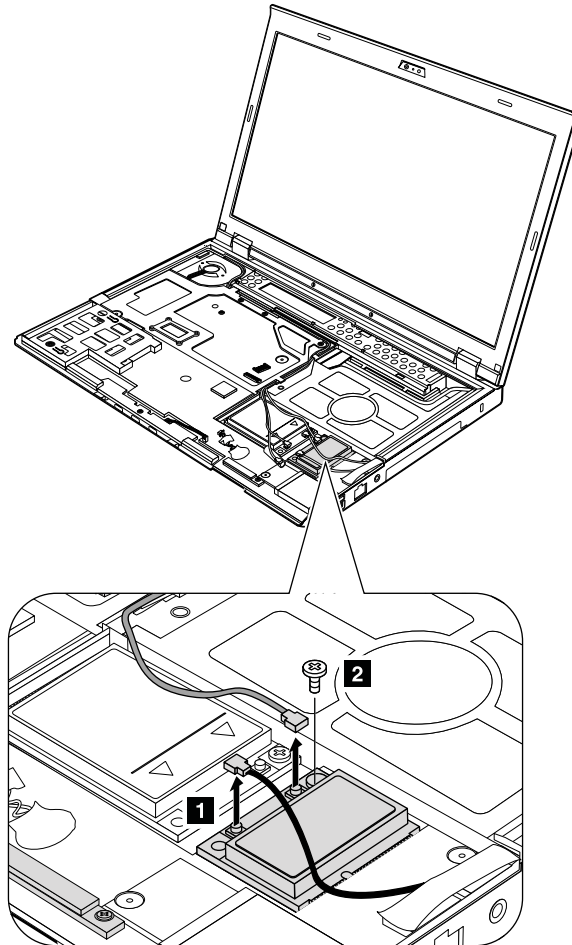

Step	Screw (quantity)	Color	Torque
2	M2 × 3 mm, wafer-head, nylon-coated (1)	Black	0.181 Nm (1.85 kgfcm)

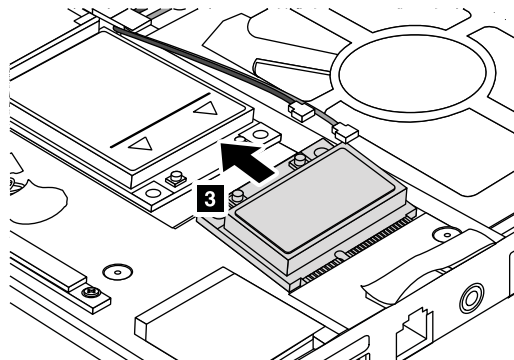

Table 14. Removal steps of PCI Express Mini Card for wireless LAN/WiMAX (continued)

When installing:

- In models with a wireless LAN card that has two antenna connectors, plug the gray cable into the jack labeled **MAIN** or **M** on the card, and the black cable into the jack labeled **AUX** or **A**. If the computer you are servicing has three cables, put the white cable in the cable protection tube.
- In models with a wireless LAN card that has three antenna connector, plug the gray cable (MAIN) into the jack labeled **TR1**, the white cable (third) into the jack labeled **RO** or **TR3**, and the black cable (AUX) into the jack labeled **TR2** on the card.

1070 Backup battery



Use only the battery specified in the parts list for your computer. Any other battery could ignite or explode.

For access, remove these FRUs in order:

- “1010 Battery pack” on page 63
- “1040 Keyboard” on page 67
- “1050 Palm rest or palm rest with a fingerprint reader” on page 69

Table 15. Removal steps of backup battery

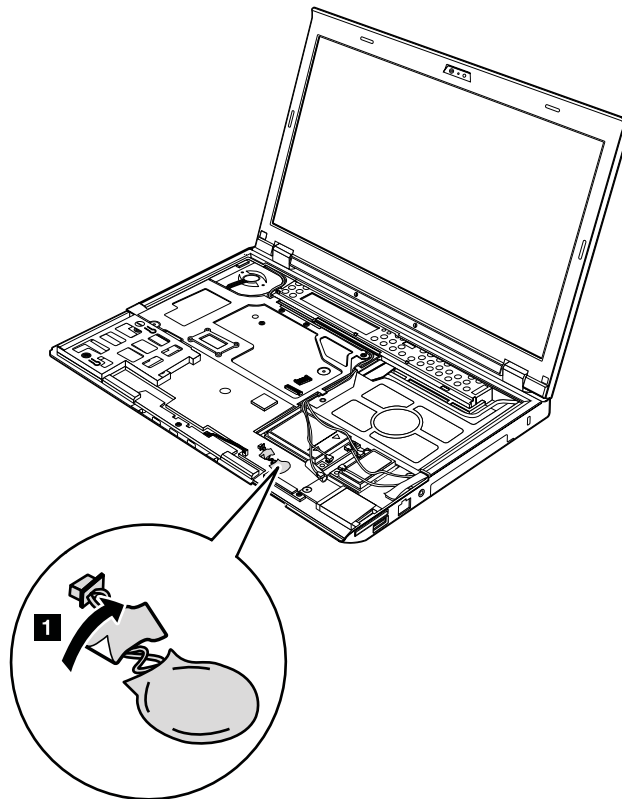
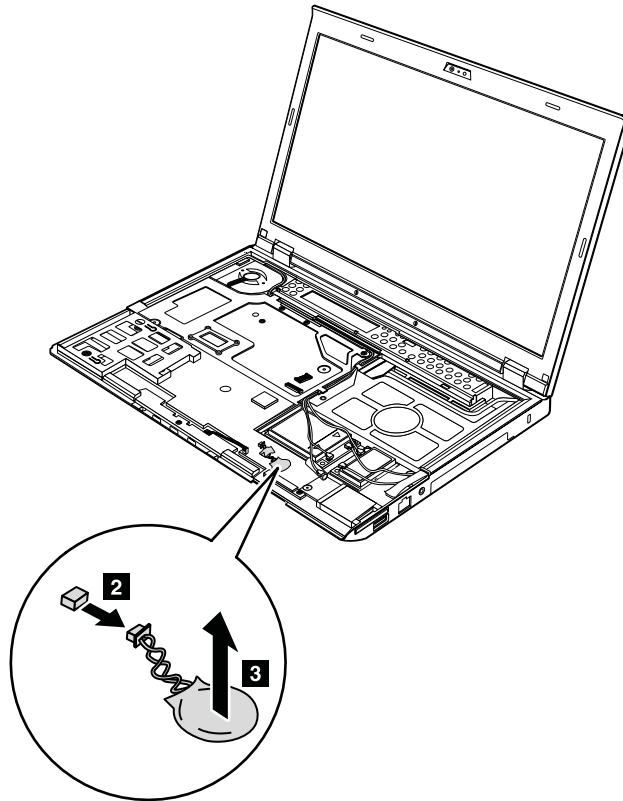

Table 15. Removal steps of backup battery (continued)



When installing:

Make sure that the battery connector is attached firmly.

1080 PCI Express Mini Card for wireless WAN

For access, remove these FRUs in order:

- “1010 Battery pack” on page 63
- “1040 Keyboard” on page 67
- “1050 Palm rest or palm rest with a fingerprint reader” on page 69

Table 16. Removal steps of PCI Express Mini Card for wireless WAN

In step **1**, unplug the jacks by using the removal tool antenna RF connector (P/N: 08K7159) or pick the connectors with your fingers and gently unplug them in the direction of the arrow.

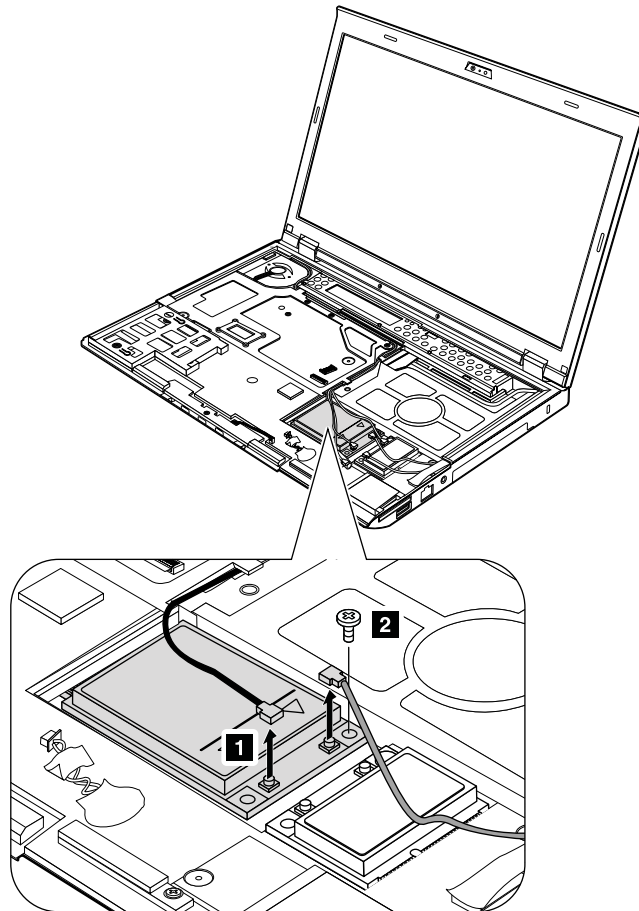

Step	Screw (quantity)	Color	Torque
2	M2 × 3 mm, wafer-head, nylon-coated (1)	Black	0.181 Nm (1.85 kgfcm)

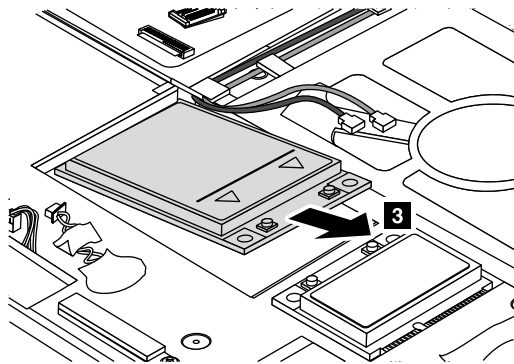

When installing:

Plug the red cable into the jack labeled **MAIN** on the card, and the blue cable into the jack labeled **AUX**.

1090 Keyboard bezel

For access, remove these FRUs in order:

- “1010 Battery pack” on page 63
- “1040 Keyboard” on page 67
- “1050 Palm rest or palm rest with a fingerprint reader” on page 69

Table 17. Removal steps of keyboard bezel

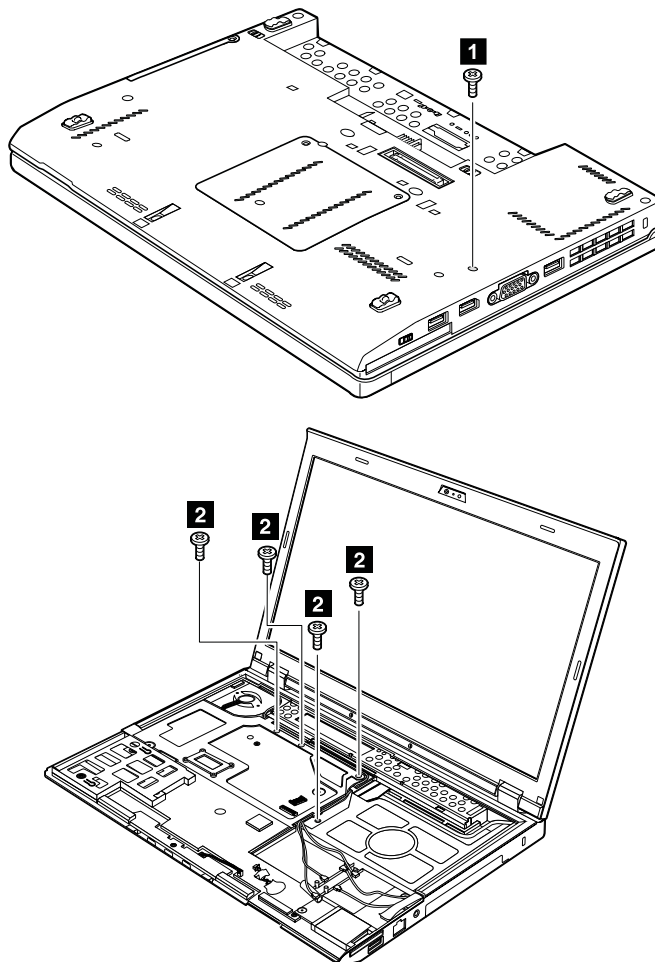

Step	Screw (quantity)	Color	Torque
1	M2 × 5 mm, wafer-head, nylon-coated (3)	Black	0.181 Nm (1.85 kgfcm)
2	M2 × 3 mm, wafer-head, nylon-coated (4)	Black	0.181 Nm (1.85 kgfcm)

Table 17. Removal steps of keyboard bezel (continued)

In step **3**, detach the claws. Then remove the keyboard bezel in the direction shown by arrow **4**.

Attention: When you service the keyboard bezel, avoid any kind of rough handling.

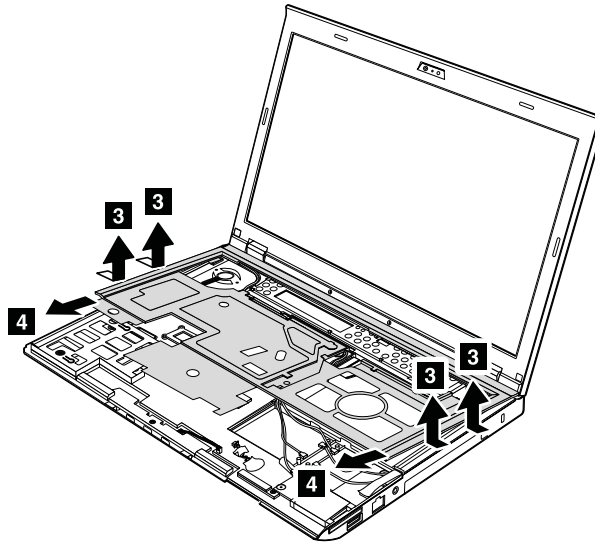

When installing:

Make sure that all the claws are attached firmly.

1100 LCD assembly

For access, remove these FRUs in order:

- “1010 Battery pack” on page 63
- “1040 Keyboard” on page 67
- “1050 Palm rest or palm rest with a fingerprint reader” on page 69
- “1060 PCI Express Mini Card for wireless LAN/WiMAX” on page 71
- “1080 PCI Express Mini Card for wireless WAN” on page 74
- “1090 Keyboard bezel” on page 76

Table 18. Removal steps of LCD assembly

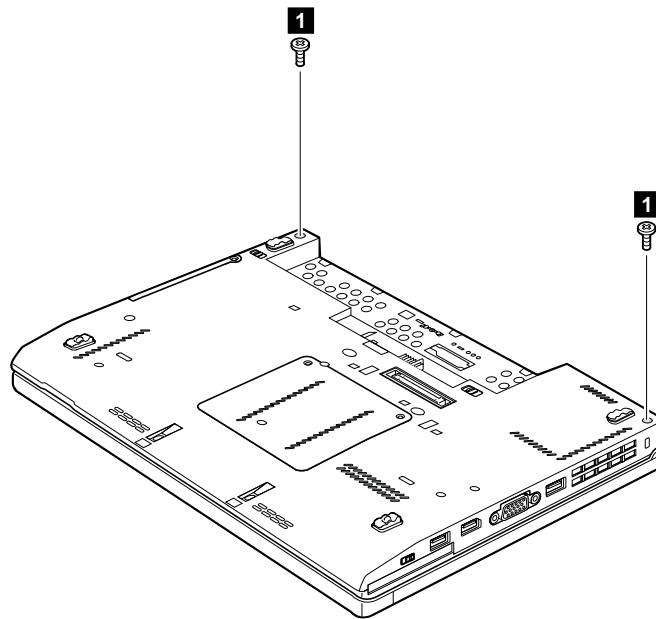

Step	Screw (quantity)	Color	Torque
1	M2 × 5 mm, wafer-head, nylon-coated (2)	Black	0.181 Nm (1.85 kgfcm)

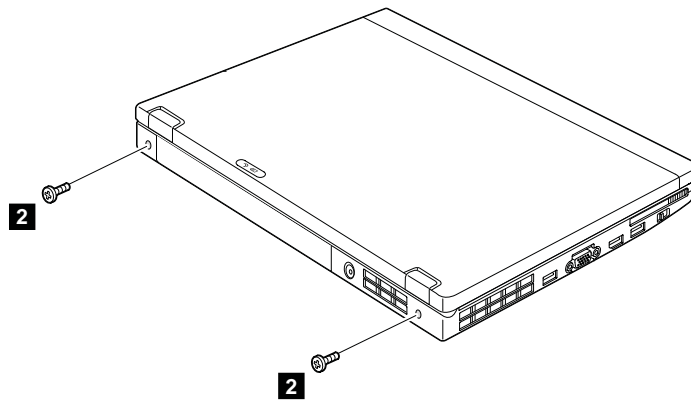

Step	Screw (quantity)	Color	Torque
2	M2 × 5 mm, wafer-head, nylon-coated (2)	Black	0.181 Nm (1.85 kgfcm)

Table 18. Removal steps of LCD assembly (continued)

Before step **3**, strip off the tapes securing the antenna cables, and release the cables from the cable guides of the frame.

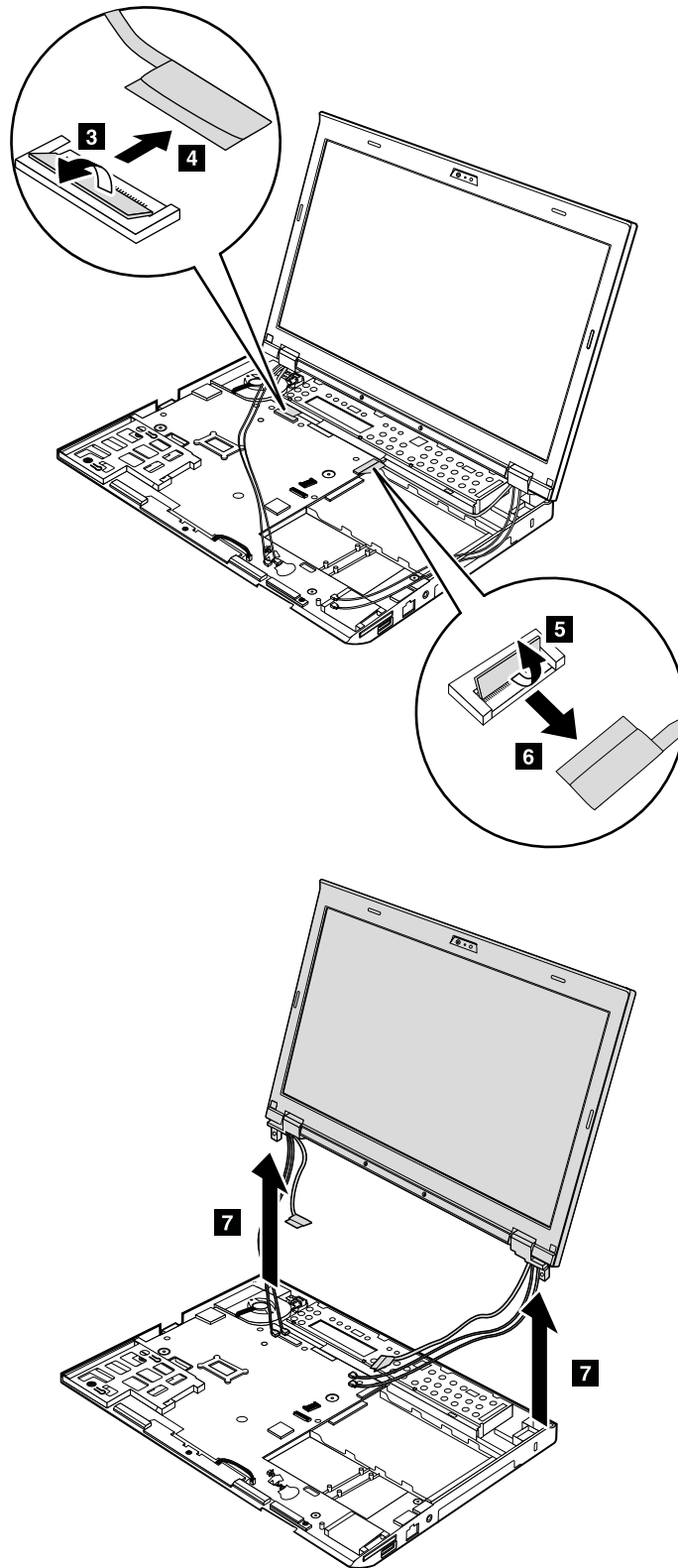
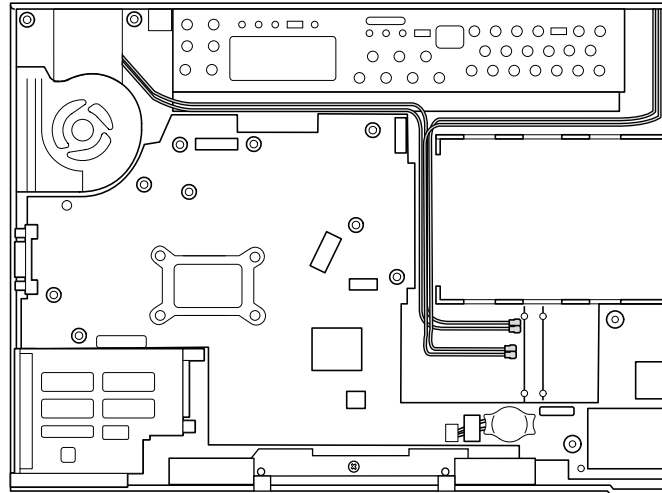

Table 18. Removal steps of LCD assembly (continued)

When installing:

- Make sure that you attach the connectors firmly.
- Make sure that you route the cables correctly and you tape up the cables in the proper positions as shown in the following figure.
- When you route the cables, make sure that they are not subjected to any tension. Tension could cause the cables to be damaged by the cable guides, or a wire to be broken.



1110 Base cover assembly and speaker assembly

For access, remove these FRUs in order:

- “1010 Battery pack” on page 63
- “1020 Hard disk drive (HDD) and solid state drive (SSD)” on page 63
- “1030 DIMM” on page 65
- “1040 Keyboard” on page 67
- “1050 Palm rest or palm rest with a fingerprint reader” on page 69
- “1070 Backup battery” on page 73
- “1060 PCI Express Mini Card for wireless LAN/WiMAX” on page 71
- “1080 PCI Express Mini Card for wireless WAN” on page 74
- “1090 Keyboard bezel” on page 76
- “1100 LCD assembly” on page 77

Table 19. Removal steps of speaker assembly

Remove the speaker assembly from the base cover assembly.

Table 19. Removal steps of speaker assembly (continued)

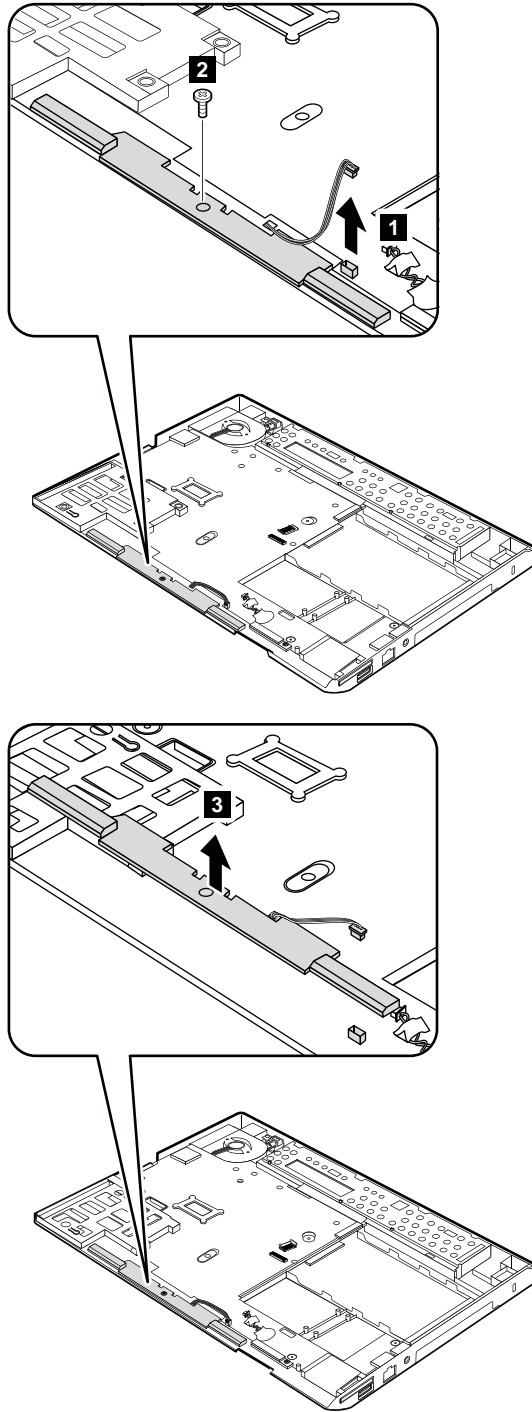

Step	Screw (quantity)	Color	Torque
2	M2 × 3mm, wafer-head, nylon-coated (1)	Black	0.181 Nm (1.85 kgfcm)

Table 19. Removal steps of speaker assembly (continued)

When installing:

Route the speaker cables along the cable guides as shown in the following figure.

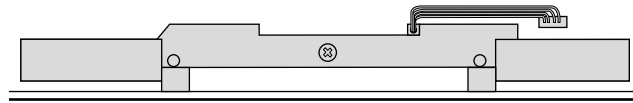
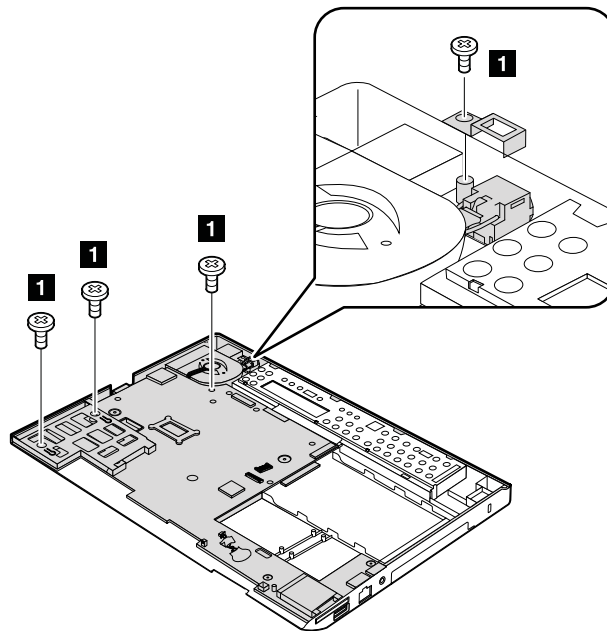
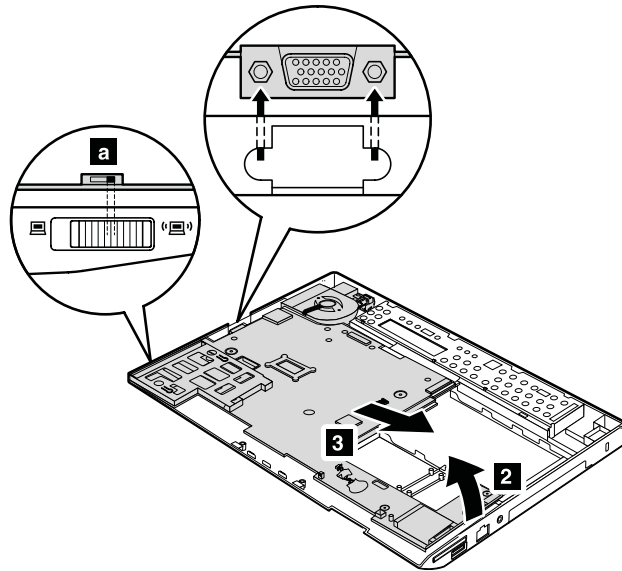

Table 20. Removal steps of base cover assembly



Step	Screw (quantity)	Color	Torque
1	M2 × 3 mm, wafer-head, nylon-coated (4)	Black	0.181 Nm (1.85 kgfcm)

Table 20. Removal steps of base cover assembly (continued)



When installing:

Make sure that the wireless switch is adjusted as shown by callout **a**.

Applying labels to the base cover:

The new base cover FRU is shipped with a kit containing labels of several kinds.

When you replace the base cover, you need to apply the following labels:

- 19** Homologation label
- 20** Product label

The following labels need to be peeled off from the old base cover, and need to be put on the new base cover.

- 1** Windows Certificate of Authentication label (COA)
- 2** China telecom label Serial number label
- 3** Ethernet label or Onboard LAN MAV address label
MAC address label
- 4** SIM label
- 5** Asset tag
- 6** IMEI label or China 3G label
- 7** Wireless card label (only for Brazil)
- 8** Modem AMOM label
- 9** MEDEM label (only for PRC model)
- 10** *Bluetooth* label
- 11** China WWAN label
- 12** Brazil WWAN label
- 13** SIRIM label or POSTEL label

14	Non-encryption label (for non-TPM model) or Rating label (only for Indonesia)
15	AT Wireless LAN MAC address label
16	Vodafone label
17	FCC label
18	Serial number label
21	FCC-ID label for contactless smart card model
22	Israel label (67.8 mm x 27.9 mm)
23	Israel label (72.2 mm x 29.7 mm)
24	Israel label (76.2 mm x 31.8 mm)

For some models, you need to apply two FCC labels, **17** and **21**. Check the old base cover; if it has two FCC labels, apply both to the new base cover.

For the location of each label, refer to the following figure:

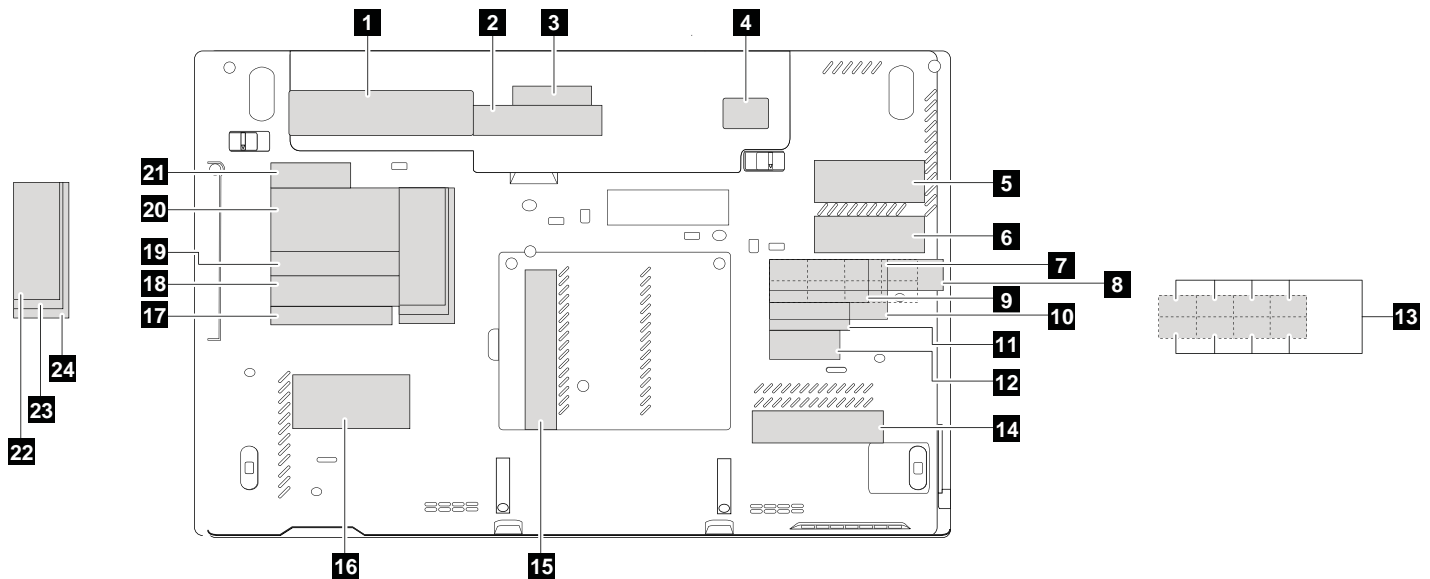

1120 Systemboard, DC-in connector, fan, and ExpressCard slot assembly

- To identify the system board originally installed in your computer, go to PEW at the following web site: <http://www.lenovo.com/support/site.wss/document.do?Indocid=LOOK-WARNTY>
Select Warranty Lookup. Input the machine type and the serial number. Use the system board listed on PEW.
- Business Partners using Eclaim can access PEW at the following web site: <https://wca.eclaim.com>
Select Entitlement Lookup. Input the Loc ID, the machine type, and the serial number. Use the system board listed on PEW.

Important notices for handling the system board:

When handling the system board, bear the following in mind.

- The system board has an accelerometer, which can be broken if several thousands of G-forces are applied.

Note: Dropping a system board from a height of as little as 6 inches so that it falls flat on a hard bench can subject the accelerometer to as much as 6,000 G's of shock.

- Be careful not to drop the system board on a bench top that has a hard surface, such as metal, wood, or composite.
- If a system board is dropped, you must test it, using PC-Doctor for DOS, to make sure that the HDD Active Protection System™ still functions.

Note: If the test shows that the HDD Active Protection System is not functioning, be sure to document the drop in a reject report, and replace the system board.

- Avoid rough handling of any kind.
- At every point in the process, be sure not to drop or stack the system board.
- If you put a system board down, be sure to put it only on a padded surface such as an ESD mat or a corrugated conductive surface.

After replacing the system board, run PC-Doctor for DOS to make sure that the HDD Active Protection System still functions. The procedure is as follows:

1. Place the computer on a horizontal surface.
2. Run **Diagnostics → ThinkPad Devices → HDD Active Protection Test**.

Attention: Do not apply physical shock to the computer while the test is running.

For access, remove these FRUs in order:

- “1010 Battery pack” on page 63
- “1020 Hard disk drive (HDD) and solid state drive (SSD)” on page 63
- “1030 DIMM” on page 65
- “1040 Keyboard” on page 67
- “1050 Palm rest or palm rest with a fingerprint reader” on page 69
- “1070 Backup battery” on page 73
- “1060 PCI Express Mini Card for wireless LAN/WiMAX” on page 71
- “1080 PCI Express Mini Card for wireless WAN” on page 74
- “1090 Keyboard bezel” on page 76
- “1100 LCD assembly” on page 77
- “1110 Base cover assembly and speaker assembly” on page 80

Table 21. Removal steps of system board, DC-in connector, fan, and ExpressCard slot assembly

The following components soldered on the system board are extremely sensitive. When you service the system board, avoid any kind of rough handling.

Table 21. Removal steps of system board, DC-in connector, fan, and ExpressCard slot assembly (continued)

- a** Platform Controller Hub (PCH)
- b** CPU
- c** Accelerometer chip for the HDD Active Protection System

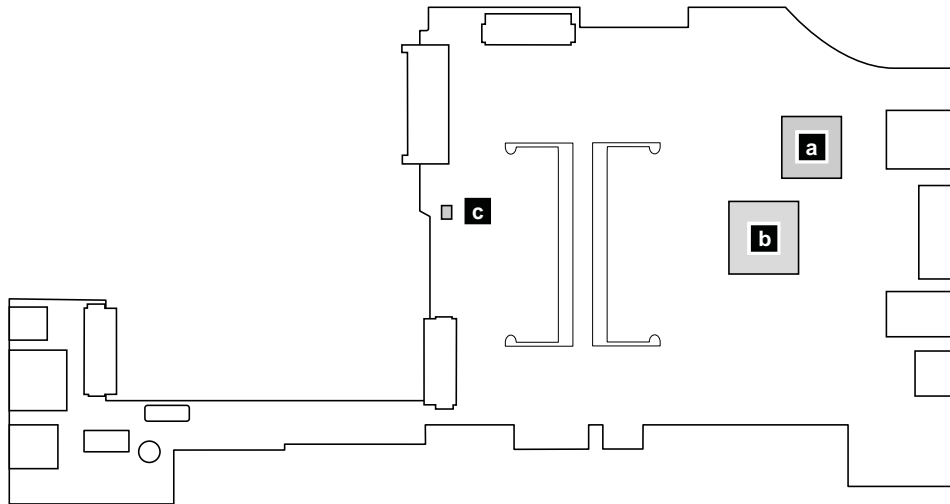

Note: The ExpressCard slot assembly is attached to the system board.

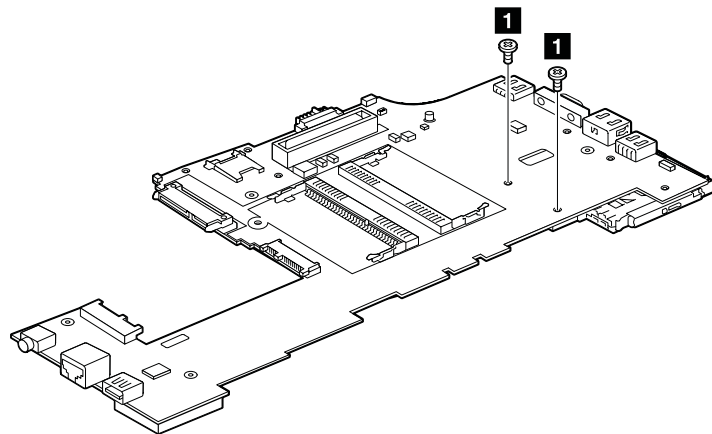

Step	Screw (quantity)	Color	Torque
1	M2 × 3.5 mm, flat-head, nylon-coated (2)	Silver	0.181 Nm (1.85 kgfcm)

Table 21. Removal steps of system board, DC-in connector, fan, and ExpressCard slot assembly (continued)

Turn the system board over, and then remove the ExpressCard slot assembly from the system board.

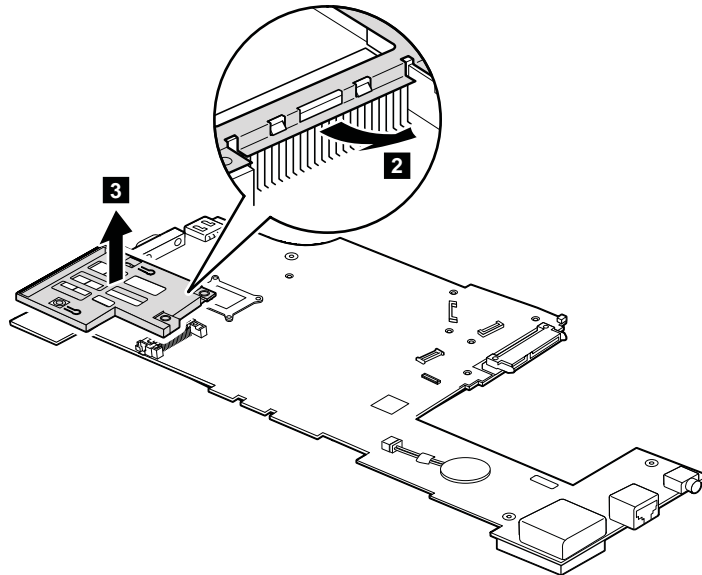

Turn the system board over, and then disconnect the DC-in connector and the fan connector from the system board.

Note: The DC-in connector and the fan assembly are attached to the underside of the system board.

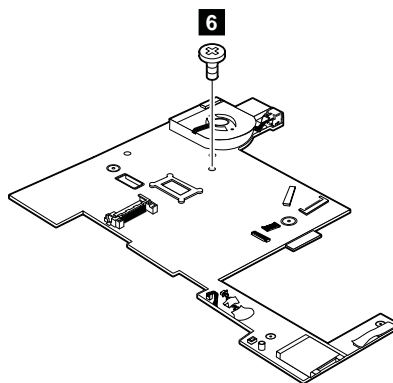
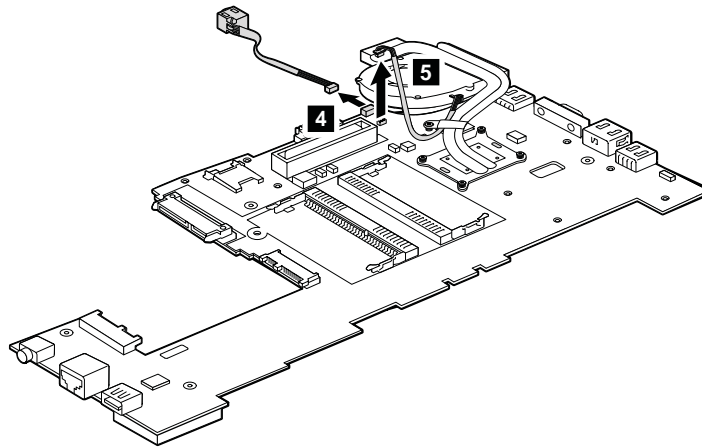
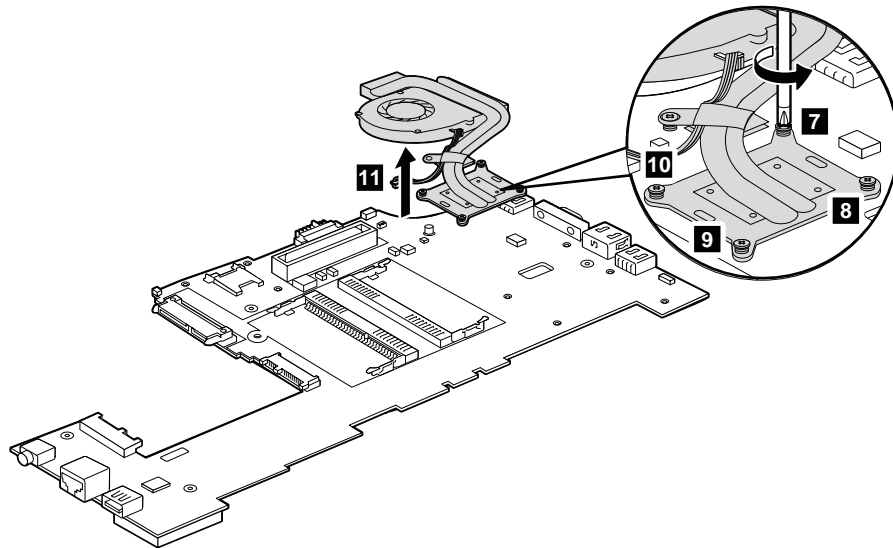

Table 21. Removal steps of system board, DC-in connector, fan, and ExpressCard slot assembly (continued)

Step	Screw (quantity)	Color	Torque
6	M2 × 3.5 mm, wafer-head, nylon-coated (1)	Silver	0.181 Nm (1.85 kgfcm)



When installing:

- Make sure that the DC-in connector and the fan connector are attached to the system board firmly.
- Before you attach the fan assembly to the computer, apply thermal grease, at an amount of 0.2 grams, on the part marked **a** as in the following figure. Either too much or too less application of grease can cause a thermal problem due to imperfect contact with a component. You need to peel the thin film off from the rubber **b**.

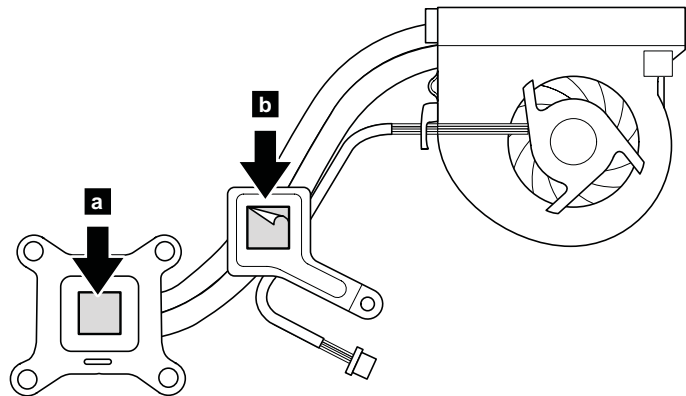

2010 LCD front bezel

For access, remove this FRU:

- “1010 Battery pack” on page 63

Table 22. Removal steps of LCD front bezel

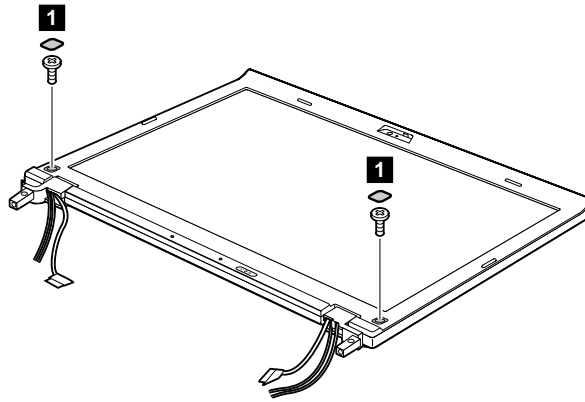

Step	Screw (quantity)	Color	Torque
1	M2.5 × 4 mm, wafer-head, nylon-coated (2)	Black	0.392 Nm (4 kgfcm)

In step **2**, detach the claws. Then remove the LCD front bezel.

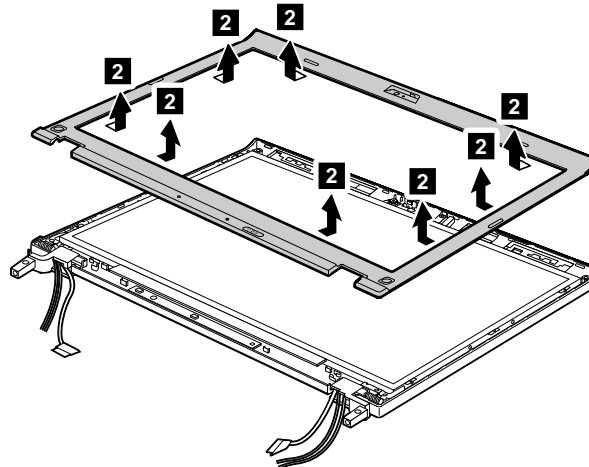

When installing:

Make sure that all the claws are attached firmly.

2020 LED board

For access, remove these FRUs in order:

- “1010 Battery pack” on page 63
- “2010 LCD front bezel” on page 88

Table 23. Removal steps of LED board

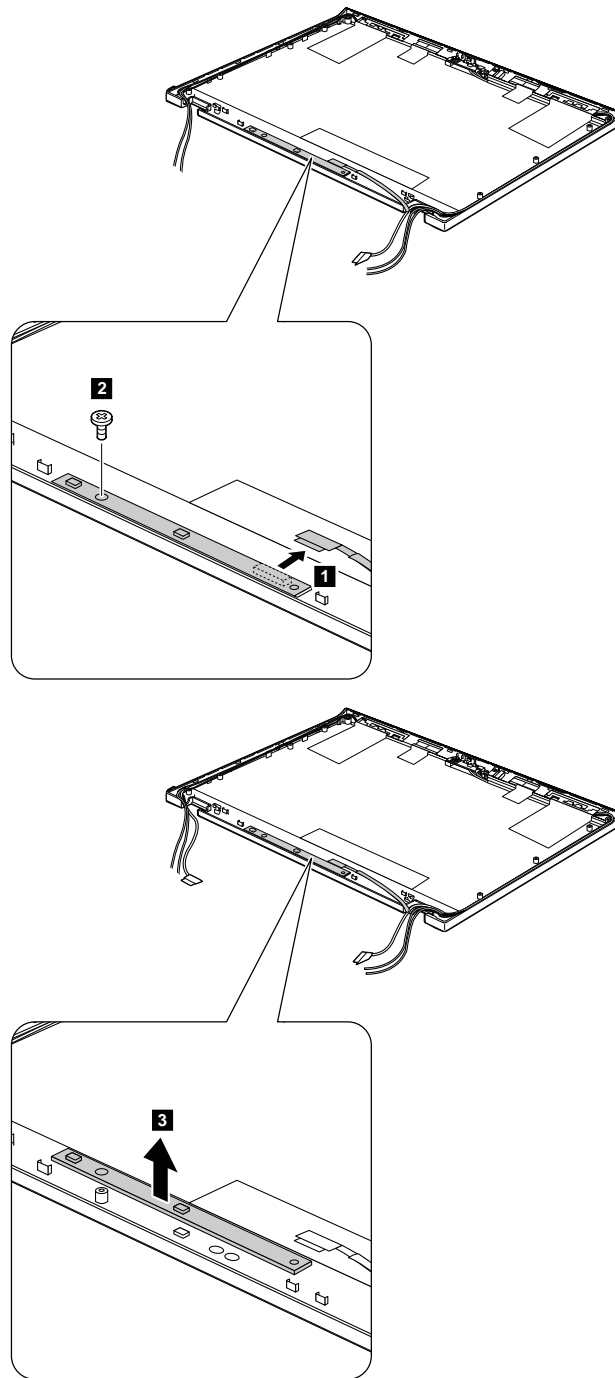

Step	Screw (quantity)	Color	Torque
2	M2 × 3.5 mm, wafer-head, nylon-coated (1)	Silver	0.181 Nm (1.85 kgfcm)

When installing: Make sure that connector **1** is attached firmly.

Table 23. Removal steps of LED board (continued)

Cabling: When replacing the inverter card or the LED board, route the connector cable as in the following figure.

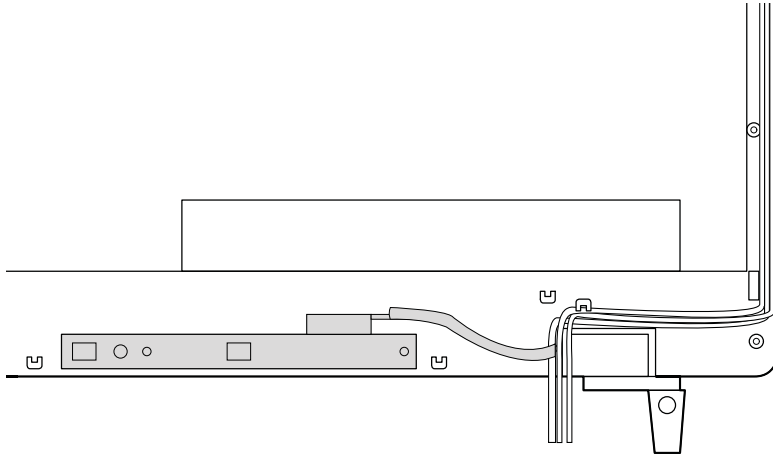

2030 Bluetooth daughter card (BDC-2.1)

For access, remove these FRUs in order:

- “1010 Battery pack” on page 63
- “2010 LCD front bezel” on page 88

Table 24. Removal steps of **Bluetooth** daughter card

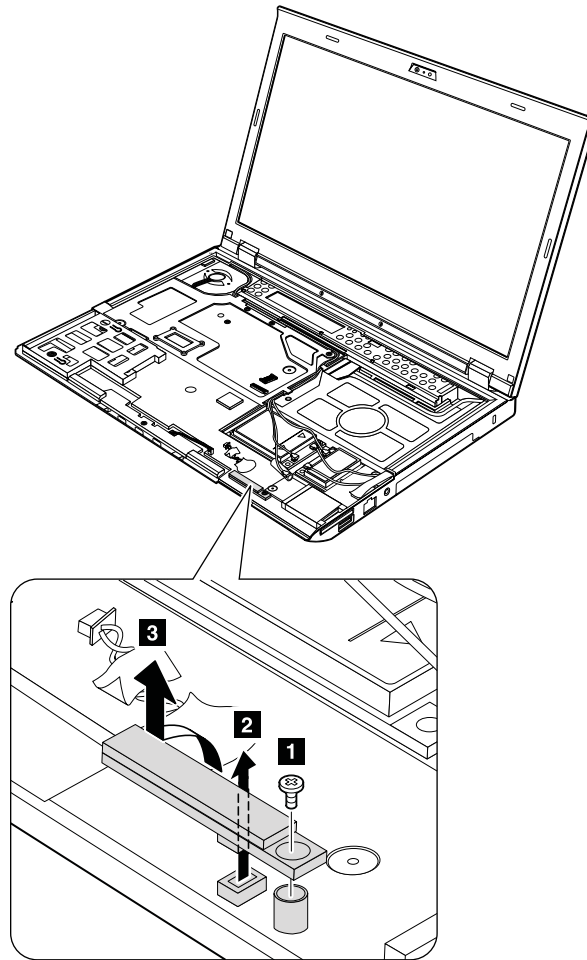

Step	Screw (quantity)	Color	Torque
1	M2 × 3 mm, wafer-head, nylon-coated (1)	Silver	0.181 Nm (1.85 kgfcm)

When installing:

Make sure that the connector is attached firmly.

2040 Integrated camera

For access, remove these FRUs in order:

- “1010 Battery pack” on page 63
- “2010 LCD front bezel” on page 88

Table 25. Removal steps of Integrated camera

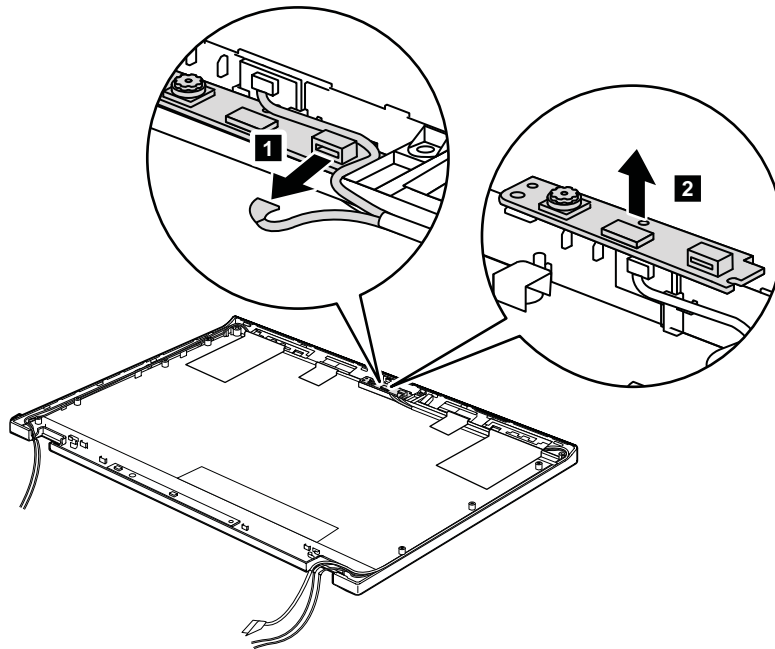

Step	Screw (quantity)	Color	Torque
1	M2 × 3.5 mm, wafer-head, nylon-coated (1)	Silver	0.181 Nm (1.85 kgfcm)

When installing:

Make sure that the connector is attached firmly.

2050 LCD panel and LCD cable

For access, remove these FRUs in order:

- “1010 Battery pack” on page 63
- “1040 Keyboard” on page 67
- “1050 Palm rest or palm rest with a fingerprint reader” on page 69
- “1060 PCI Express Mini Card for wireless LAN/WiMAX” on page 71
- “1080 PCI Express Mini Card for wireless WAN” on page 74
- “1090 Keyboard bezel” on page 76
- “1100 LCD assembly” on page 77
- “2010 LCD front bezel” on page 88
- “2020 LED board” on page 89
- “2030 Bluetooth daughter card (BDC-2.1)” on page 91
- “2040 Integrated camera” on page 92

Table 26. Removal steps of LCD panel, LCD brackets, and LCD cable

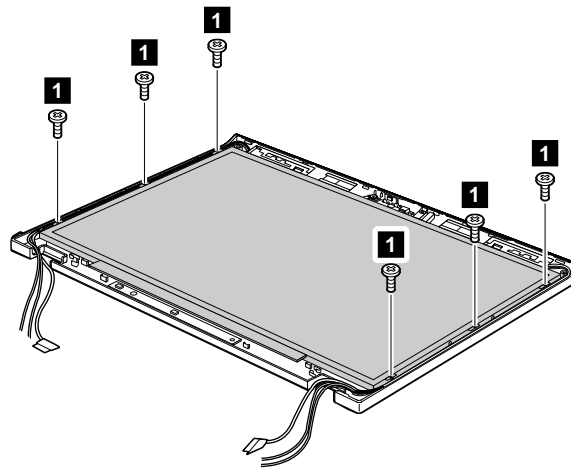

Step	Screw (quantity)	Color	Torque
1	M2 × 3.5 mm, wafer-head, nylon-coated (6)	Silver	0.181 Nm (1.85 kgfcm)

In step **2**, release the antenna cables from the cable guides, and then remove the LCD panel.

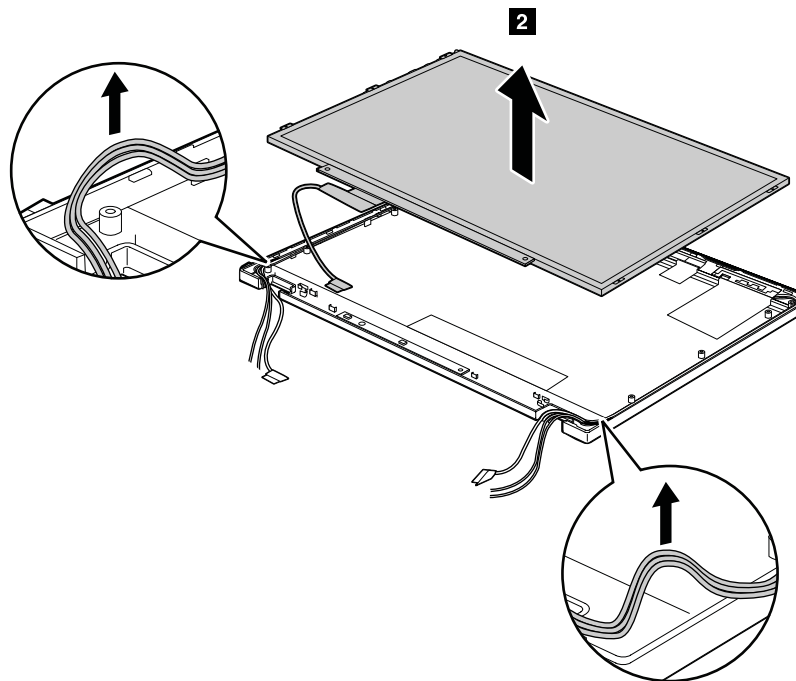

When installing:

When attaching the LCD panel to the cover, gently press the left and right edges covered with metal. Do not press the surface of the panel or apply any excessive force to the panel.

Table 26. Removal steps of LCD panel, LCD brackets, and LCD cable (continued)

Turn the LCD panel over, and then remove the LCD cable from the LCD panel.

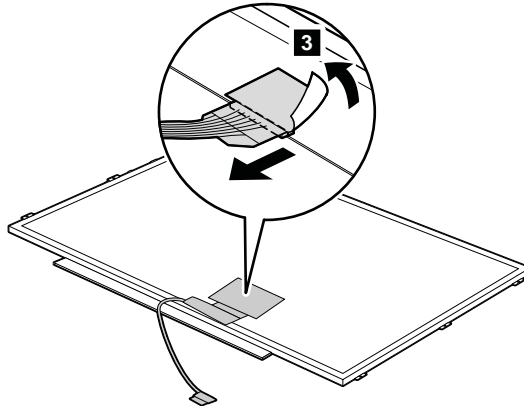

When installing:

Make sure that the LCD cable connector is attached firmly.

2060 Hinges

For access, remove these FRUs in order:

- “1010 Battery pack” on page 63
- “1040 Keyboard” on page 67
- “1050 Palm rest or palm rest with a fingerprint reader” on page 69
- “1060 PCI Express Mini Card for wireless LAN/WiMAX” on page 71
- “1080 PCI Express Mini Card for wireless WAN” on page 74
- “1090 Keyboard bezel” on page 76
- “1100 LCD assembly” on page 77
- “2010 LCD front bezel” on page 88
- “2020 LED board” on page 89
- “2030 *Bluetooth* daughter card (BDC-2.1)” on page 91
- “2040 Integrated camera” on page 92
- “2050 LCD panel and LCD cable” on page 93

Table 27. Removal steps of hinges

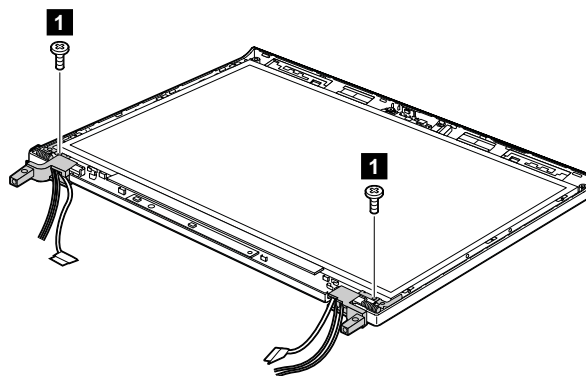
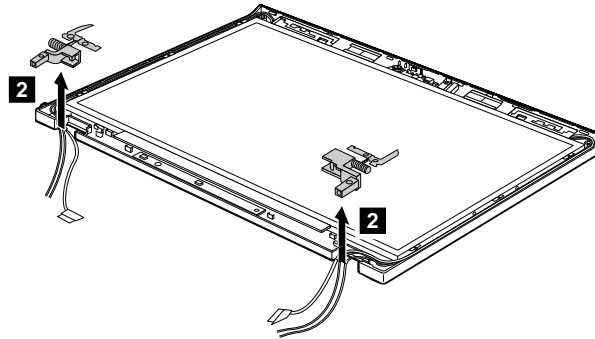

Table 27. Removal steps of hinges (continued)

Step	Screw (quantity)	Color	Torque
1	M2.5 x 4 mm, wafer-head, nylon-coated (2)	Black	0.392 Nm (4 kgfcm)



2070 LCD rear cover and wireless antenna cables

For access, remove these FRUs in order:

- “1010 Battery pack” on page 63
- “1040 Keyboard” on page 67
- “1050 Palm rest or palm rest with a fingerprint reader” on page 69
- “1060 PCI Express Mini Card for wireless LAN/WiMAX” on page 71
- “1080 PCI Express Mini Card for wireless WAN” on page 74
- “1090 Keyboard bezel” on page 76
- “1100 LCD assembly” on page 77
- “2010 LCD front bezel” on page 88
- “2020 LED board” on page 89
- “2030 *Bluetooth* daughter card (BDC-2.1)” on page 91
- “2040 Integrated camera” on page 92
- “2050 LCD panel and LCD cable” on page 93
- “2060 Hinges” on page 95

Table 28. Removal steps of LCD rear cover and wireless antenna cables

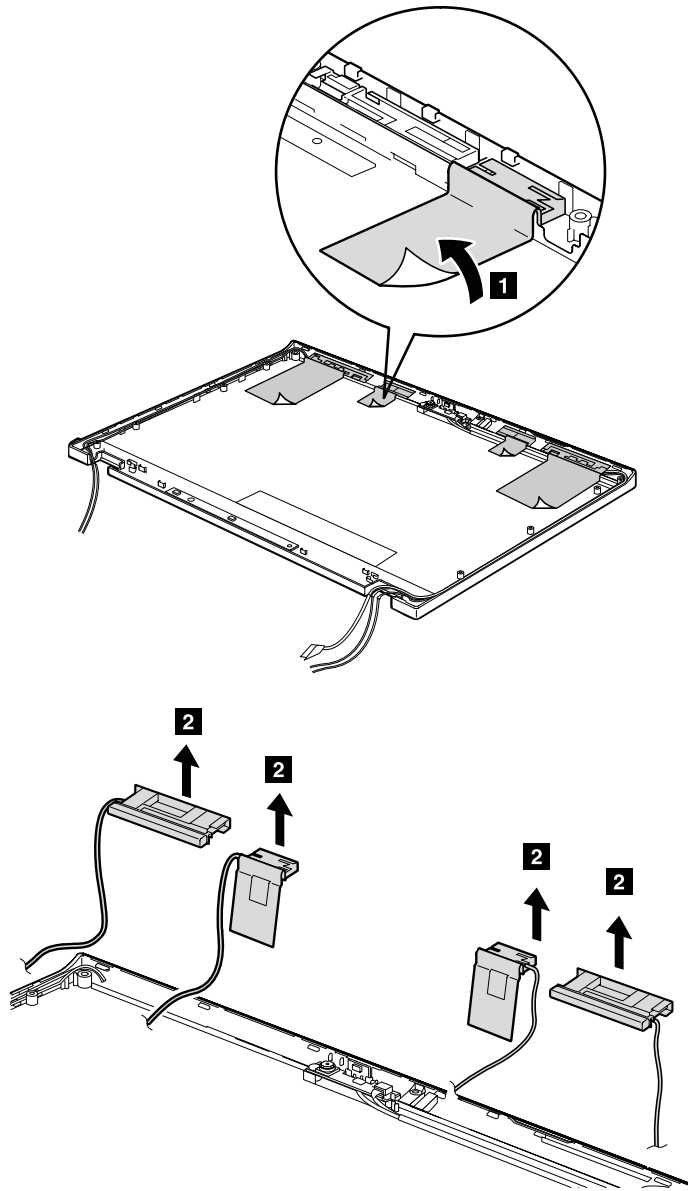

In step **2**, release the antenna cables from the cable guides of the rear cover.

Table 28. Removal steps of LCD rear cover and wireless antenna cables (continued)

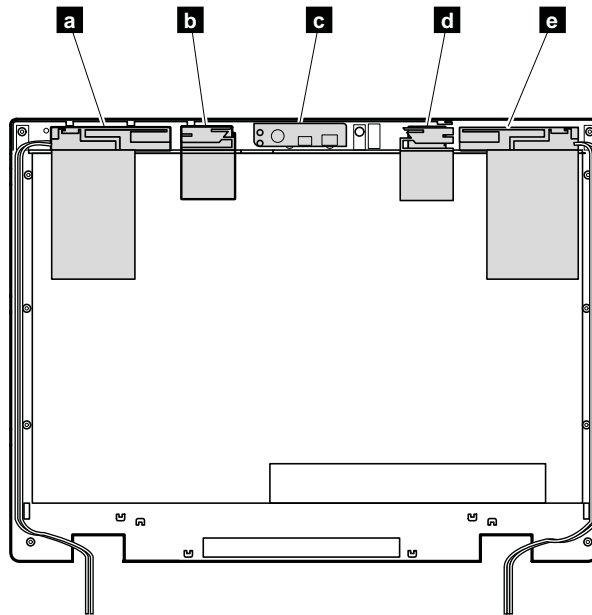

Note: Wireless antennas are secured with double-faced adhesive tapes.

When installing:

When you attach the antenna cables, place the antenna assembly as shown in the above figure.

- | | |
|----------|-----------------------------------|
| a | Wireless WAN antenna, AUX (blue) |
| b | Wireless LAN antenna, AUX (black) |
| c | MIMO antenna (white) |
| d | Wireless LAN antenna, MAIN (gray) |
| e | Wireless WAN antenna, MAIN (red) |

Attention: As you route the antenna cables, make sure that they are not subjected to any tension. Tension could cause the cables to be damaged by the cable guides, or a wire to be broken.

Chapter 9. Locations

This chapter presents the location of ThinkPad X220 and X220i features and hardware components.

Front view

- 1** ThinkLight light
- 2** Status indicators
Note: For the description of each indicator, see Chapter 5 “Status indicators” on page 51.
- 3** Security keyhole
- 4** Hard disk drive (HDD) or solid state drive (SSD)
- 5** Combo audio jack
- 6** Ethernet connector
- 7** Always On USB connector
- 8** Media card reader slot
- 9** TrackPoint pointing stick
- 10** TrackPoint buttons
- 11** Touch pad
- 12** UltraNav®
- 13** Volume control buttons
- 14** ThinkVantage button
- 15** Power switch
- 16** Integrated camera

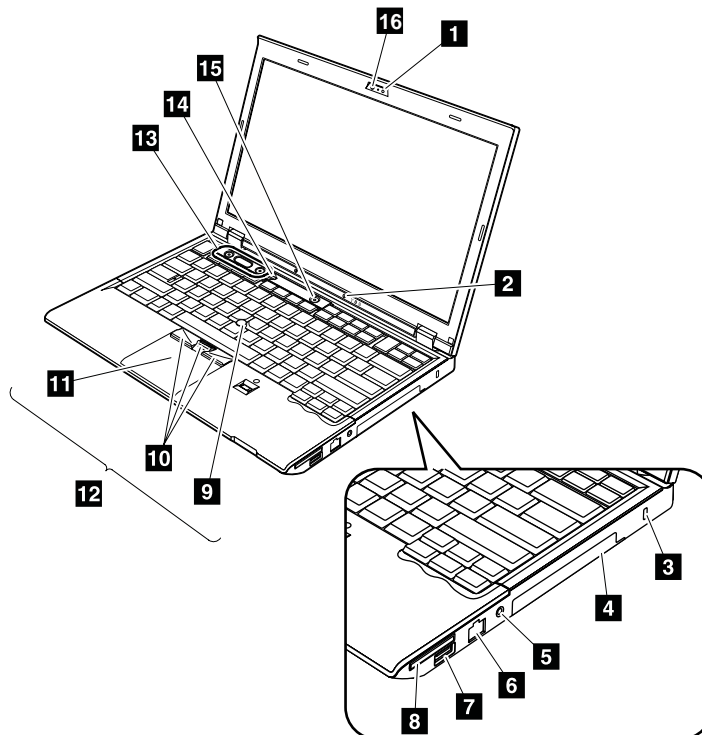

Rear view

- 1** Status indicators
- 2** ExpressCard slot
- 3** Wireless radio switch
- 4** USB connector
- 5** DisplayPort connector
- 6** External monitor connector
- 7** USB connector
- 8** ac power connector

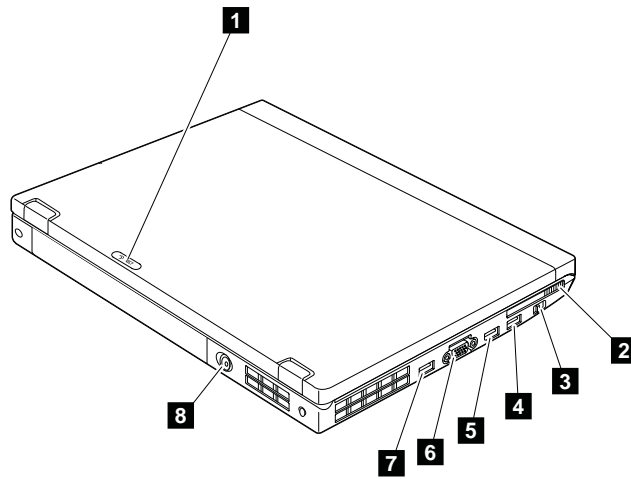

Bottom view

1

Battery pack latch

2

Battery pack

3

Docking connector

4

DIMM slot

5

Built-in speaker

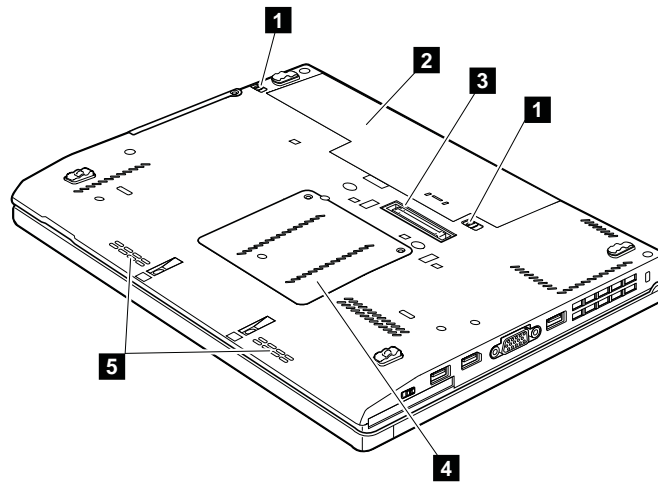

Top view (ThinkPad X220 UltraBase)

- 1** Docking connector
- 2** ac power connector
- 3** Ethernet connector
- 4** DisplayPort connector
- 5** External monitor connector
- 6** Headphone jack
- 7** Microphone jack
- 8** USB connectors
- 9** Security keyhole
- 10** Security lock key
- 11** Serial Ultrabay Slim device

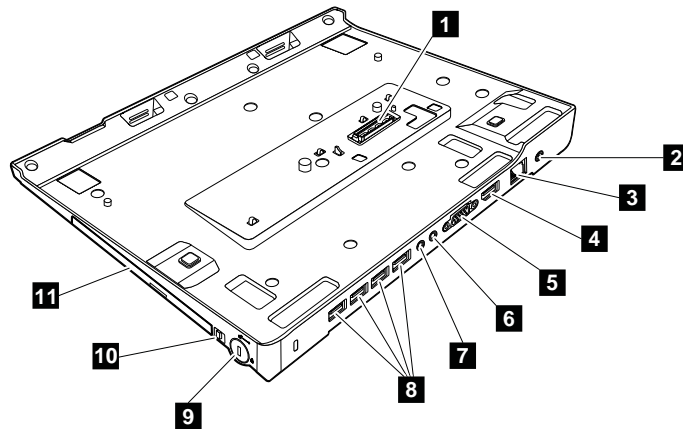

Bottom view (ThinkPad X220 UltraBase)

- 1** UltraBase eject request button
- 2** Docking indicator
- 3** UltraBase eject lever
- 4** Holes for speakers

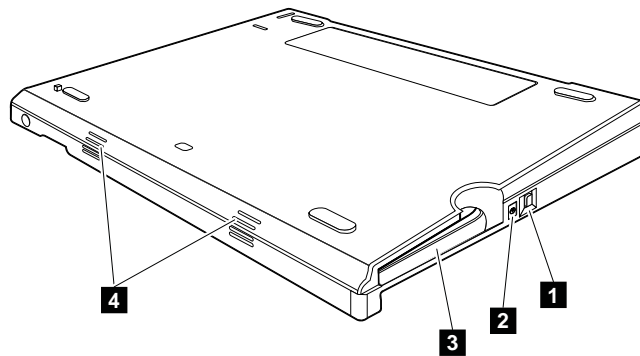

Front View (ThinkPad Port Replicator Series 3)

- 1** Power switch
- 2** Eject button
- 3** Sliding adjuster
- 4** Docking connector

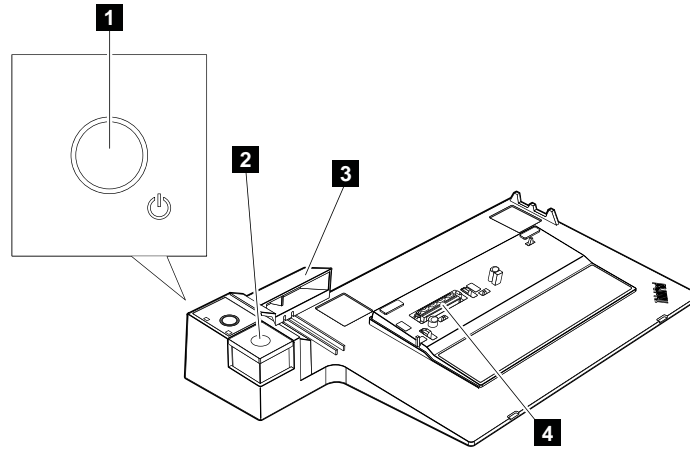

Rear View (ThinkPad Port Replicator Series 3)

- 1** Power jack
- 2** Ethernet connector
- 3** USB connectors
- 4** External monitor connector
- 5** Security keyhole

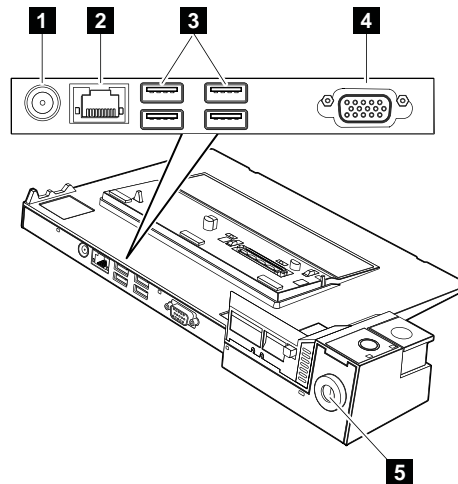

Front View (ThinkPad Mini Dock Series 3)

- 1** Power switch
- 2** Key lock indicator
- 3** Docking indicator
- 4** Eject button
- 5** Sliding adjuster
- 6** Docking connector
- 7** System lock key

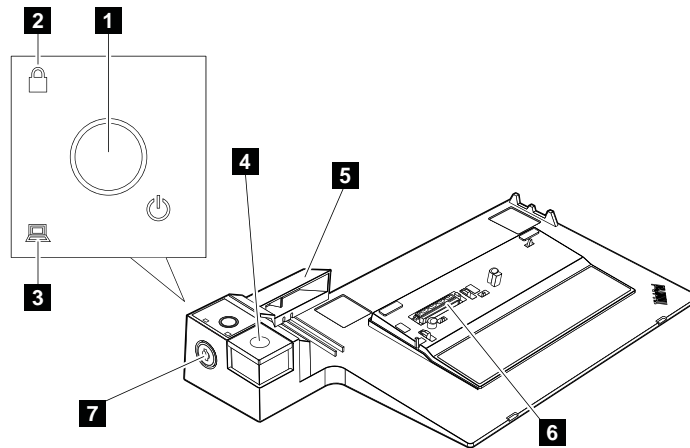

Rear View (ThinkPad Mini Dock Series 3)

- 1** Power jack
- 2** DisplayPort connector
- 3** Digital visual interface connector
- 4** Headphone jack
- 5** Microphone jack
- 6** Ethernet connector
- 7** USB connectors
- 8** External monitor connector
- 9** Security keyhole

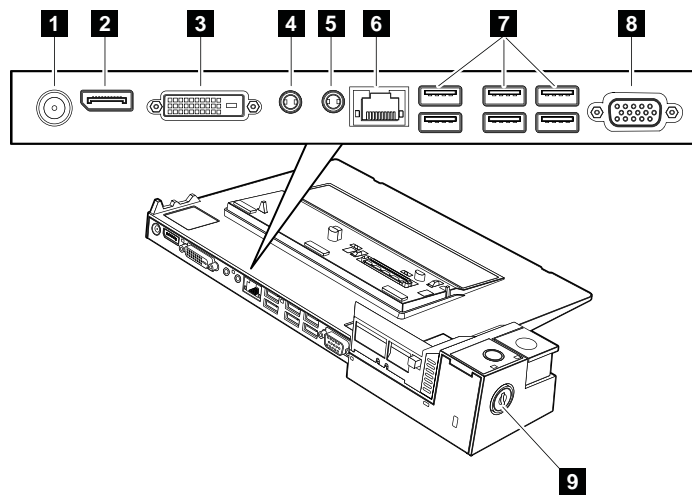

Front View (ThinkPad Mini Dock Plus Series 3)

- 1** Key lock indicator
- 2** Power switch
- 3** Docking indicator
- 4** Eject button
- 5** Sliding adjuster
- 6** Microphone jack
- 7** Headphone jack
- 8** Docking connector
- 9** System lock key

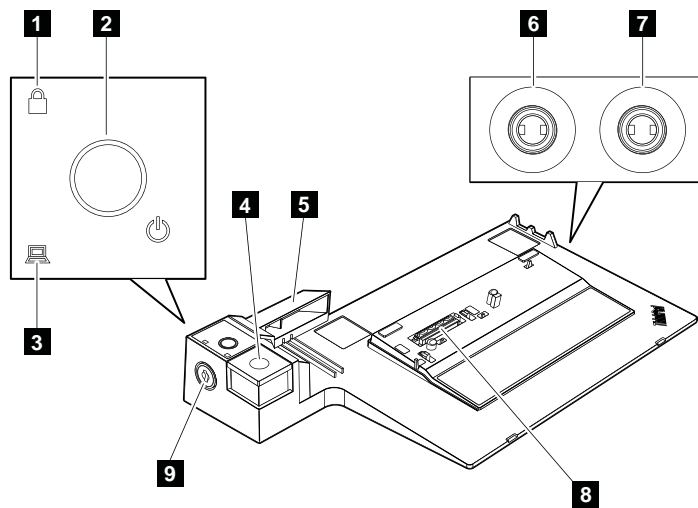

Rear View (ThinkPad Mini Dock Plus Series 3)

- 1** DisplayPort connector
- 2** Digital visual interface connector
- 3** DisplayPort connector
- 4** Digital visual interface connector
- 5** Ethernet connector
- 6** USB connectors
- 7** Power jack
- 8** Security keyhole
- 9** External monitor connector
- 10** eSATA

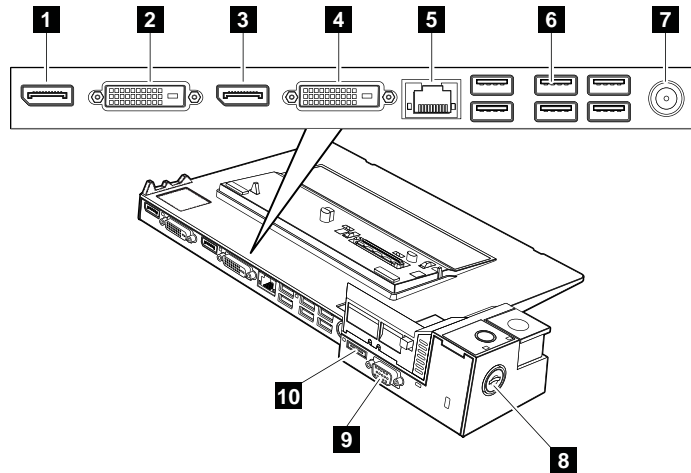

Chapter 10. Parts list

This section contains following lists of the service parts.

- “Overall” on page 110
- “LCD FRUs” on page 120
- “Keyboard” on page 123
- “Miscellaneous parts” on page 125
- “AC adapters” on page 125
- “Power cords” on page 125
- “Recovery discs” on page 126
- “Common service tools” on page 132

Notes:

- Each FRU is available for all types or models, unless specific types or models are specified.
- FRU with specific models listed and described as xxU (where U is an example of a country designator) should be used for all models ending in U.
- FRU with specific models listed and described as 3Dx (where 3D is an example of a unique configuration) should be used for all of these models, unless specific country or region designator is specified.
- A CRU (customer replaceable unit) is identified by a single asterisk (*) or two asterisks (**) in the CRU ID column. An N in the CRU ID column means that the part is not a CRU. A single asterisk (*) means that the part is a Self-service CRU; two asterisks (**) means that the part is an Optional-service CRU.

External CRU statement to customers:

Some problems with your product can be resolved with a replacement part you can install yourself, called a “Customer Replaceable Unit” or “CRU.” Some CRUs are designated as Self-service CRUs and others are designated as Optional-service CRUs. *Installation of Self-service CRUs is your responsibility; you may request that Lenovo installs an Optional-service CRU according to the warranty service for your product.* Where you are installing the CRU, Lenovo will ship the CRU to you. CRU information and replacement instructions are shipped with your product and are available from Lenovo at any time upon request. You may find a list of CRUs in the publications that ship with your product or at <http://www.lenovo.com/CRUs>. You may be required to return the defective part that is replaced by the CRU. When return is required: (1) return instructions, a prepaid shipping label, and a container will be included with the replacement CRU; and (2) you may be charged for the replacement CRU if Lenovo does not receive the defective part within thirty (30) days of your receipt of the replacement CRU. See your Lenovo Limited Warranty documentation for full details.

ThinkPad computers contain the following types of CRUs:

- **Self-service CRUs:** These CRUs unplug or are held by no more than two screws. Examples of these types of CRUs include the ac power adapter, power cord, battery, and hard disk drive. Other Self-service CRUs depending on product design may include the memory module, wireless card, keyboard, and palm rest with finger print reader and touchpad.
 - **Optional-service CRUs:** These CRUs are isolated parts within the computer that are concealed by an access panel that is typically secured by more than two screws. Once the access panel is removed, the specific CRU is visible.
- FRUs marked with **OP** are available as options.

Overall

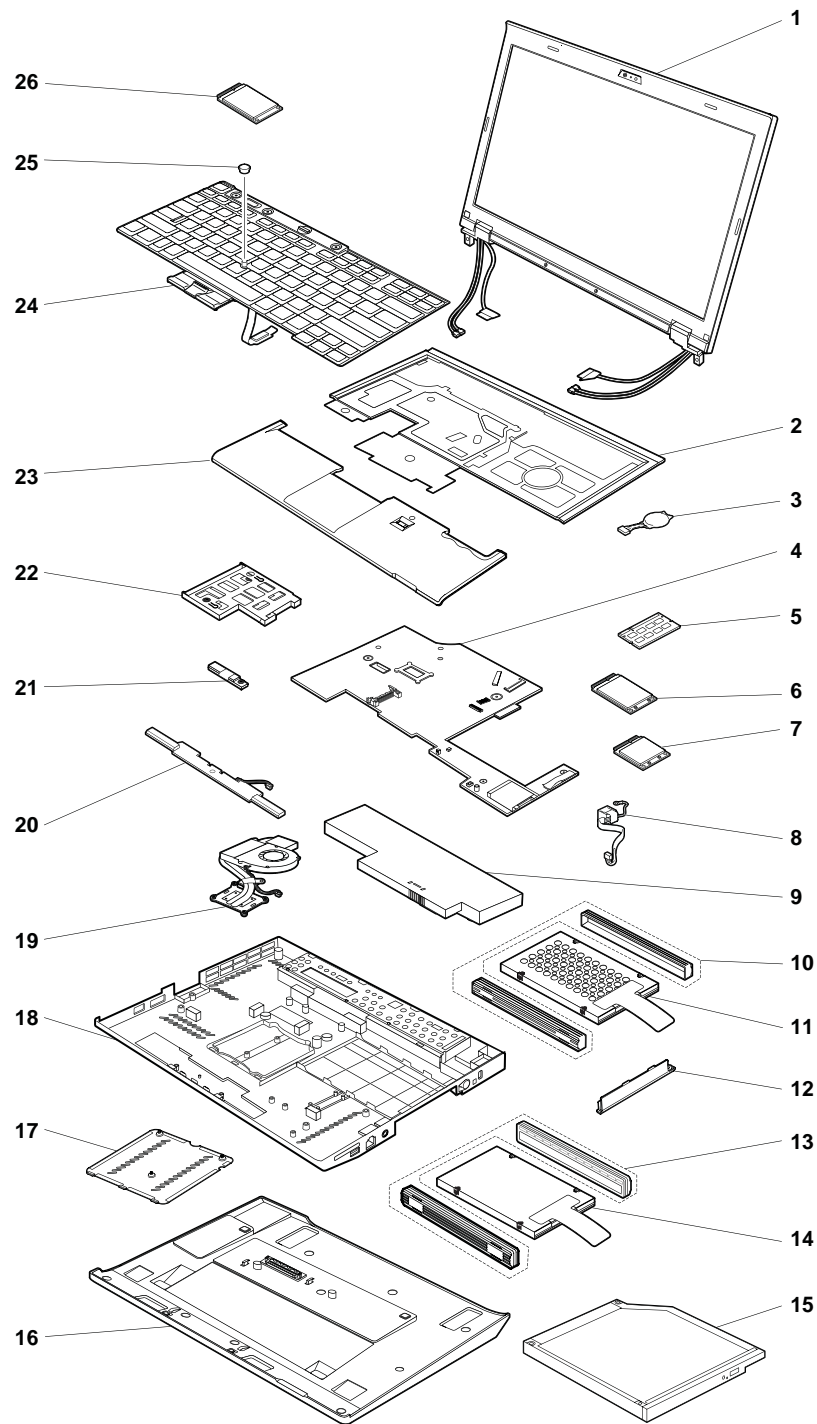

Table 29. Parts list—Overall

No.	FRU	FRU no.	CRU ID
1	LCD unit (see “LCD FRUs” on page 120.)		
2	Keyboard bezel assembly	04W1405	N

Table 29. Parts list—Overall (continued)

No.	FRU	FRU no.	CRU ID
3	Backup battery	02K7078	N
4	System board with Intel® Core™ i5-2520M processor, NV, AMT, TPM, AES <ul style="list-style-type: none"> • 4286- 25x, 29x • 4287-29x, 2Bx, 2Kx, 2Sx, 2Tx, 2Vx, 2Wx, 34x • 4290-2Ex, 2Fx, 2Gx, 2Kx, 2Lx, 2Mx, 2Vx, 2Zx, 34x, 3Ax, 3Bx, 3Dx, 3Hx, 3Kx, 3Lx, 3Mx, 3Nx • 4291-26x, 27x, 29x, 2Bx, 2Ex, 2Hx, 2Px, 2Wx, 2Yx, 2Zx 	04W1423	N
4	System board with Intel Core i5-2520M processor, NV, AMT, non-TPM, non-AES <ul style="list-style-type: none"> • 4286-CTO • 4287-CTO • 4289-CTO • 4290-CTO • 4291-CTO 	04W1424	N
4	System board with Intel Core i5-2520M processor, NV, non-AMT, TPM, AES <ul style="list-style-type: none"> • 4287-2Gx, 33x 	04W1526	N
4	System board with Intel Core i5-2520M processor, NV, non-AMT, non-TPM, non-AES <ul style="list-style-type: none"> • 4286-CTO • 4287-CTO • 4289-CTO • 4290-CTO • 4291-CTO 	04W1527	N
4	System board with Intel Core i5-2540M processor, NV, AMT, TPM, AES <ul style="list-style-type: none"> • 4287-27x, 28x, 2Px • 4290-2Bx, 2Cx, 2Dx, 2Hx, 2Jx, 2Nx, 2Px, 2Qx, 2Wx, 2Xx, 32x, 33x, 3Cx, 3Gx, 3Tx • 4291-2Fx, 2Gx, 2Jx, 2Kx, 2Lx, 2Nx, 2Tx 	04W1425	N
4	System board with Intel Core i5-2540M processor, NV, AMT, non-TPM, non-AES <ul style="list-style-type: none"> • 4286-CTO • 4287-CTO • 4289-CTO • 4290-CTO • 4291-CTO 	04W1426	N
4	System board with Intel Core i5-2540M processor, NV, non-AMT, TPM, AES <ul style="list-style-type: none"> • 4287-32x 	04W1528	N
4	System board with Intel Core i5-2540M processor, NV, non-AMT, non-TPM, non-AES <ul style="list-style-type: none"> • 4286-CTO • 4287-CTO • 4289-CTO • 4290-CTO • 4291-CTO 	04W1529	N

Table 29. Parts list—Overall (continued)

No.	FRU	FRU no.	CRU ID
4	System board with Intel Core i7-2620M processor, NV, AMT, TPM, AES <ul style="list-style-type: none"> • 4286- 28x • 4287-26x, 2Qx, 2Xx • 4290-2Ax, 2Rx, 2Sx, 2Tx, 2Ux, 2Yx, 37x, 38x, 39x, 3Fx, 3Sx • 4291-28x, 2Cx, 2Dx, 2Mx, 2Vx, 2Xx, 35x, 36x, 37x 	04W1427	N
4	System board with Intel Core i7-2620M processor, NV, AMT, non-TPM, non-AES <ul style="list-style-type: none"> • 4286-CTO • 4287-CTO • 4289-CTO • 4290-CTO • 4291-CTO 	04W1428	N
4	System board with Intel Core i7-2620M processor, NV, non-AMT, TPM, AES <ul style="list-style-type: none"> • 4287-2Zx • 4291-2Rx 	04W1530	N
4	System board with Intel Core i7-2620M processor, NV, non-AMT, non-TPM, non-AES <ul style="list-style-type: none"> • 4286-CTO • 4287-CTO • 4289-CTO • 4290-CTO • 4291-CTO 	04W1531	N
4	System board with Intel Core i5-2537M processor, ULV, AMT, TPM, AES <ul style="list-style-type: none"> • 4286- 27x • 4287-2Jx • 4290-3Px • 4291-32x, 34x 	04W1429	N
4	System board with Intel Core i5-2537M processor, ULV, AMT, non-TPM, non-AES <ul style="list-style-type: none"> • 4286-CTO • 4287-CTO • 4289-CTO • 4290-CTO • 4291-CTO 	04W1430	N
4	System board with Intel Core i5-2537M processor, ULV, non-AMT, TPM, AES <ul style="list-style-type: none"> • 4286-CTO • 4287-CTO • 4289-CTO • 4290-CTO • 4291-CTO 	04W1532	N

Table 29. Parts list—Overall (continued)

No.	FRU	FRU no.	CRU ID
4	System board with Intel Core i5-2537M processor, ULV, non-AMT, non-TPM, non-AES <ul style="list-style-type: none"> • 4286-CTO • 4287-CTO • 4289-CTO • 4290-CTO • 4291-CTO 	04W1533	N
4	System board with Intel Core i3-2310M processor, NV, TPM, non-AES <ul style="list-style-type: none"> • 4286- 2Kx, 2Lx • 4287-22x, 35x, 38x, 39x, 3Ax, 3Bx • 4289-22x • 4290-26x, 27x, 28x 	04W1431	N
4	System board with Intel Core i3-2310M processor, NV, non-TPM, non-AES <ul style="list-style-type: none"> • 4286- 2Bx, 2Cx, 2Dx, 2Ex, 2Fx, 2Gx, 2Hx, 2Jx • 4287-36x, 37x 	04W1432	N
4	System board with Intel Core i5-2410M processor, NV, TPM, non-AES <ul style="list-style-type: none"> • 4286-23x, 24x, 26x, 2Ax • 4287-2Ax, 2Hx, 2Lx, 2Mx, 2Nx, 2Rx, 2Ux, 2Yx • 4290-35x, 36x, 3Ex, 3Jx, 3Qx, 3Rx • 4291-2Qx, 2Sx, 2Ux, 33x 	04W1433	N
4	System board with Intel Core i5-2410M processor, NV, non-TPM, non-AES <ul style="list-style-type: none"> • 4287-24x, 2Cx, 2Dx, 2Ex, 2Fx 	04W1434	N
5	1-GB DDR3-1333 SDRAM SO-DIMM (PC3-10600) card Low Halogen <ul style="list-style-type: none"> • 4291-2Tx 	55Y3715	**
5	2-GB DDR3-1333 SDRAM SO-DIMM (PC3-10600) card Low Halogen <ul style="list-style-type: none"> • 4286-23x, 24x, 25x, 26x, 2Ax, 2Bx, 2Dx, 2Ex, 2Fx, 2Gx, 2Hx, 2Jx • 4287-24x, 2Dx, 2Ex, 2Fx, 2Mx, 2Nx, 2Rx, 2Sx, 2Tx, 2Ux, 2Yx, 2Zx, 32x, 33x, 34x, 36x, 37x, 39x • 4290-2Fx, 2Gx, 34x, 36x, 3Nx, 3Px, 3Qx, 3Rx • 4291-27x, 29x, 2Jx, 2Nx, 2Px, 2Qx, 2Sx, 2Ux, 32x, 33x 	55Y3716	**
5	4-GB DDR3-1333 SDRAM SO-DIMM (PC3-10600) card Low Halogen <ul style="list-style-type: none"> • 4286-29x, 2Cx, 2Kx, 2Lx • 4287-22x, 26x, 27x, 28x, 29x, 2Ax, 2Bx, 2Cx, 2Gx, 2Hx, 2Jx, 2Kx, 2Lx, 2Px, 2Qx, 2Vx, 2Wx, 2Xx, 35x, 38x, 3Ax, 3Bx • 4289-22x • 4290-26x, 27x, 28x, 2Ax, 2Bx, 2Cx, 2Dx, 2Ex, 2Hx, 2Jx, 2Kx, 2Lx, 2Mx, 2Nx, 2Px, 2Qx, 2Rx, 2Sx, 2Tx, 2Ux, 2Vx, 2Wx, 2Xx, 2Yx, 2Zx, 32x, 33x, 35x, 37x, 38x, 39x, 3Ax, 3Bx, 3Cx, 3Dx, 3Ex, 3Gx, 3Hx, 3Jx, 3Kx, 3Lx, 3Mx, 3Sx, 3Tx • 4291-26x, 28x, 2Bx, 2Cx, 2Dx, 2Ex, 2Fx, 2Gx, 2Hx, 2Kx, 2Lx, 2Mx, 2Rx, 2Vx, 2Wx, 2Xx, 2Yx, 2Zx, 34x, 35x, 36x, 37x 	55Y3717	**

Table 29. Parts list—Overall (continued)

No.	FRU	FRU no.	CRU ID
6	Integrated Mobile Broadband (Gobi 3000 3G with GPS) <ul style="list-style-type: none"> • 4286-CTO • 4287-CTO • 4289-CTO • 4290-CTO • 4291-CTO 	60Y3257	**
6	Integrated Mobile Broadband (Gobi 3000 Malaysia) <ul style="list-style-type: none"> • 4286-CTO • 4287-CTO • 4289-CTO • 4290-CTO • 4291-CTO 	60Y3283	**
6	Integrated Mobile Broadband (Ericsson F5521gw) <ul style="list-style-type: none"> • 4287-26x, 27x, 28x, 29x, 2Mx, 2Rx • 4290-2Ax, 2Bx, 2Cx, 38x, 39x, 3Ax, 3Bx, 3Cx, 3Sx, 3Tx • 4291-2Bx, 2Cx, 2Dx, 35x, 37x 	60Y3277	**
6	Integrated Mobile Broadband (Ericsson F5521gw Malaysia SKU) <ul style="list-style-type: none"> • 4286-CTO • 4287-CTO • 4289-CTO • 4290-CTO • 4291-CTO 	60Y3267	**
6	Integrated China Telecom Mobile Broadband (Huawei EM660) <ul style="list-style-type: none"> • 4290-2Nx, 2Px, 2Ux, 2Vx 	60Y3239	**
7	ThinkPad b/g/n Wireless (1x1 BGN) <ul style="list-style-type: none"> • 4286-2Bx, 2Cx, 2Dx, 2Ex, 2Fx, 2Gx, 2Hx, 2Jx • 4287-24x, 2Cx, 2Dx, 2Ex, 2Fx, 36x, 37x, 3Ax, 3Bx • 4289-22x • 4290-27x, 28x 	60Y3247	**
7	ThinkPad b/g/n Wireless (1x1 BGN) <ul style="list-style-type: none"> • 4286-2Bx, 2Cx, 2Dx, 2Ex, 2Fx, 2Gx, 2Hx, 2Jx • 4287-24x, 2Cx, 2Dx, 2Ex, 2Fx, 36x, 37x, 3Ax, 3Bx • 4289-22x • 4290-27x, 28x 	60Y3249	**
7	Intel Centrino Wireless-N 1000 <ul style="list-style-type: none"> • 4286-24x, 2Kx, 2Lx • 4287-22x, 2Gx, 2Hx, 2Yx, 2Zx, 32x, 33x, 38x • 4290-3Ex, 3Jx • 4291-2Qx, 2Rx 	60Y3241	**

Table 29. Parts list—Overall (continued)

No.	FRU	FRU no.	CRU ID
7	Intel Centrino Advanced-N 6205 (2x2 AGN) <ul style="list-style-type: none"> • 4286-23x, 25x, 26x, 27x, 28x, 29x, 2Ax • 4287-26x, 27x, 28x, 29x, 2Ax, 2Bx, 2Jx, 2Kx, 2Lx, 2Mx, 2Nx, 2Px, 2Qx, 2Rx, 2Sx, 2Tx, 2Ux, 2Vx, 2Wx, 2Xx, 35x, 39x • 4290-26x, 2Ax, 2Bx, 2Cx, 2Dx, 2Ex, 2Fx, 2Gx, 2Hx, 2Jx, 2Kx, 2Lx, 2Mx, 2Nx, 2Px, 2Qx, 2Rx, 2Sx, 2Tx, 2Ux, 2Vx, 2Xx, 2Yx, 32x, 33x, 34x, 35x, 36x, 37x, 38x, 39x, 3Ax, 3Bx, 3Cx, 3Dx, 3Fx, 3Gx, 3Hx, 3Kx, 3Lx, 3Mx, 3Nx, 3Px, 3Qx, 3Rx, 3Sx, 3Tx • 4291-26x, 27x, 28x, 29x, 2Bx, 2Cx, 2Dx, 2Ex, 2Gx, 2Hx, 2Jx, 2Kx, 2Lx, 2Mx, 2Nx, 2Px, 2Sx, 2Tx, 2Ux, 2Vx, 2Wx, 2Xx, 2Yx, 2Zx, 32x, 33x, 34x, 35x, 36x, 37x 	60Y3253	**
7	Intel Centrino Ultimate-N 6300 <ul style="list-style-type: none"> • 4290-2Wx, 2Zx • 4291-2Fx 	60Y3233	**
7	Intel Centrino Advanced-N + WiMAX 6250 <ul style="list-style-type: none"> • 4287-34x 	60Y3195	**
7	Intel Centrino Advanced-N + WiMAX 6250, Russian SKU <ul style="list-style-type: none"> • 4286-CTO • 4287-CTO • 4289-CTO • 4290-CTO • 4291-CTO 	60Y3209	**
8	DC-in cable assembly	04W1680	N
9	Battery pack, 4 cell, 2.0Ah <ul style="list-style-type: none"> • 4286-2Ax, 2Jx • 4287-2Yx, 2Zx, 32x, 33x, 34x 	42T4899	*
9	Battery pack, 4 cell, 2.0Ah <ul style="list-style-type: none"> • 4286-2Ax, 2Jx • 4287-2Yx, 2Zx, 32x, 33x, 34x 	42T4901	*
9	Battery pack, 6cell, 2.8Ah <ul style="list-style-type: none"> • 4286-23x, 24x, 25x, 26x, 29x, 2Bx, 2Cx, 2Dx, 2Ex, 2Fx, 2Gx, 2Hx, 2Kx, 2Lx • 4287-22x, 24x, 26x, 27x, 28x, 29x, 2Ax, 2Bx, 2Cx, 2Dx, 2Ex, 2Fx, 2Gx, 2Hx, 2Jx, 2Kx, 2Lx, 2Mx, 2Nx, 2Px, 2Qx, 2Rx, 2Sx, 2Tx, 2Ux, 2Vx, 2Wx, 2Xx, 35x, 36x, 37x, 38x, 39x, 3Ax, 3Bx • 4289-22x • 4290-26x, 27x, 28x, 2Ax, 2Bx, 2Cx, 2Dx, 2Ex, 2Fx, 2Gx, 2Jx, 2Kx, 2Lx, 2Mx, 2Nx, 2Px, 2Qx, 2Rx, 2Sx, 2Tx, 2Vx, 2Wx, 2Zx, 32x, 34x, 36x, 37x, 3Ax, 3Bx, 3Dx, 3Ex, 3Fx, 3Gx, 3Hx, 3Jx, 3Kx, 3Lx, 3Mx, 3Nx, 3Px, 3Qx, 3Rx, 3Tx • 4291-26x, 27x, 29x, 2Bx, 2Ex, 2Fx, 2Jx, 2Kx, 2Qx, 2Tx, 2Ux, 2Yx, 2Zx, 32x, 33x, 34x, 35x, 36x 	42T4861	*

Table 29. Parts list—Overall (continued)

No.	FRU	FRU no.	CRU ID
9	Battery pack, 6cell, 47+ <ul style="list-style-type: none"> • 4286-23x, 24x, 25x, 26x, 29x, 2Bx, 2Cx, 2Dx, 2Ex, 2Fx, 2Gx, 2Hx, 2Kx, 2Lx • 4287-22x, 24x, 26x, 27x, 28x, 29x, 2Ax, 2Bx, 2Cx, 2Dx, 2Ex, 2Fx, 2Gx, 2Hx, 2Jx, 2Kx, 2Lx, 2Mx, 2Nx, 2Px, 2Qx, 2Rx, 2Sx, 2Tx, 2Ux, 2Vx, 2Wx, 2Xx, 35x, 36x, 37x, 38x, 39x, 3Ax, 3Bx • 4289-22x • 4290-26x, 27x, 28x, 2Ax, 2Bx, 2Cx, 2Dx, 2Ex, 2Fx, 2Gx, 2Jx, 2Kx, 2Lx, 2Mx, 2Nx, 2Px, 2Qx, 2Rx, 2Sx, 2Tx, 2Vx, 2Wx, 2Zx, 32x, 34x, 36x, 37x, 3Ax, 3Bx, 3Dx, 3Ex, 3Fx, 3Gx, 3Hx, 3Jx, 3Kx, 3Lx, 3Mx, 3Nx, 3Px, 3Qx, 3Rx, 3Tx • 4291-26x, 27x, 29x, 2Bx, 2Ex, 2Fx, 2Jx, 2Kx, 2Qx, 2Tx, 2Ux, 2Yx, 2Zx, 32x, 33x, 34x, 35x, 36x 	42T4865	*
9	Battery pack, 6cell, 47+ <ul style="list-style-type: none"> • 4286-23x, 24x, 25x, 26x, 29x, 2Bx, 2Cx, 2Dx, 2Ex, 2Fx, 2Gx, 2Hx, 2Kx, 2Lx • 4287-22x, 24x, 26x, 27x, 28x, 29x, 2Ax, 2Bx, 2Cx, 2Dx, 2Ex, 2Fx, 2Gx, 2Hx, 2Jx, 2Kx, 2Lx, 2Mx, 2Nx, 2Px, 2Qx, 2Rx, 2Sx, 2Tx, 2Ux, 2Vx, 2Wx, 2Xx, 35x, 36x, 37x, 38x, 39x, 3Ax, 3Bx • 4289-22x • 4290-26x, 27x, 28x, 2Ax, 2Bx, 2Cx, 2Dx, 2Ex, 2Fx, 2Gx, 2Jx, 2Kx, 2Lx, 2Mx, 2Nx, 2Px, 2Qx, 2Rx, 2Sx, 2Tx, 2Vx, 2Wx, 2Zx, 32x, 34x, 36x, 37x, 3Ax, 3Bx, 3Dx, 3Ex, 3Fx, 3Gx, 3Hx, 3Jx, 3Kx, 3Lx, 3Mx, 3Nx, 3Px, 3Qx, 3Rx, 3Tx • 4291-26x, 27x, 29x, 2Bx, 2Ex, 2Fx, 2Jx, 2Kx, 2Qx, 2Tx, 2Ux, 2Yx, 2Zx, 32x, 33x, 34x, 35x, 36x 	42T4873	*
9	Battery pack, 6cell, 47+ <ul style="list-style-type: none"> • 4286-23x, 24x, 25x, 26x, 29x, 2Bx, 2Cx, 2Dx, 2Ex, 2Fx, 2Gx, 2Hx, 2Kx, 2Lx • 4287-22x, 24x, 26x, 27x, 28x, 29x, 2Ax, 2Bx, 2Cx, 2Dx, 2Ex, 2Fx, 2Gx, 2Hx, 2Jx, 2Kx, 2Lx, 2Mx, 2Nx, 2Px, 2Qx, 2Rx, 2Sx, 2Tx, 2Ux, 2Vx, 2Wx, 2Xx, 35x, 36x, 37x, 38x, 39x, 3Ax, 3Bx • 4289-22x • 4290-26x, 27x, 28x, 2Ax, 2Bx, 2Cx, 2Dx, 2Ex, 2Fx, 2Gx, 2Jx, 2Kx, 2Lx, 2Mx, 2Nx, 2Px, 2Qx, 2Rx, 2Sx, 2Tx, 2Vx, 2Wx, 2Zx, 32x, 34x, 36x, 37x, 3Ax, 3Bx, 3Dx, 3Ex, 3Fx, 3Gx, 3Hx, 3Jx, 3Kx, 3Lx, 3Mx, 3Nx, 3Px, 3Qx, 3Rx, 3Tx • 4291-26x, 27x, 29x, 2Bx, 2Ex, 2Fx, 2Jx, 2Kx, 2Qx, 2Tx, 2Ux, 2Yx, 2Zx, 32x, 33x, 34x, 35x, 36x 	42T4875	*
9	Battery pack, 9 cell, 47++ <ul style="list-style-type: none"> • 4286-27x, 28x • 4290-2Hx, 2Ux, 2Xx, 2Yx, 33x, 35x, 38x, 39x, 3Cx, 3Sx • 4291-28x, 2Cx, 2Dx, 2Gx, 2Hx, 2Lx, 2Mx, 2Nx, 2Px, 2Rx, 2Sx, 2Vx, 2Wx, 2Xx, 37x 	42T4940	*
9	Battery pack, 9 cell, 47++ <ul style="list-style-type: none"> • 4286-27x, 28x • 4290-2Hx, 2Ux, 2Xx, 2Yx, 33x, 35x, 38x, 39x, 3Cx, 3Sx • 4291-28x, 2Cx, 2Dx, 2Gx, 2Hx, 2Lx, 2Mx, 2Nx, 2Px, 2Rx, 2Sx, 2Vx, 2Wx, 2Xx, 37x 	42T4942	*
9	Slice battery, 6 cell, 47++ <ul style="list-style-type: none"> • 4286-24x, 25x, 26x, 27x, 28x, 29x • 4287-2Qx, 2Rx, 2Sx, 2Tx, 2Ux • 4290-26x, 27x, 28x, 3Tx • 4291-28x, 29x 	42T4903	*

Table 29. Parts list—Overall (continued)

No.	FRU	FRU no.	CRU ID
10	Hard disk drive rubber rails	04W1716	**
11	SATA hard disk drive, 250GB, 5,400 rpm <ul style="list-style-type: none"> • 4286-24x • 4291-29x 	42T1153	**
11	SATA hard disk drive, 250GB, 5,400 rpm <ul style="list-style-type: none"> • 4286-24x • 4291-29x 	42T1167	**
11	SATA hard disk drive, 320GB, 5,400 rpm <ul style="list-style-type: none"> • 4290-27x, 28x 	42T1155	**
11	SATA hard disk drive, 160 GB, 7,200 rpm <ul style="list-style-type: none"> • 4286-CTO • 4287-CTO • 4289-CTO • 4290-CTO • 4291-CTO 	42T1157	**
11	SATA hard disk drive, 160 GB, 7,200 rpm <ul style="list-style-type: none"> • 4286-CTO • 4287-CTO • 4289-CTO • 4290-CTO • 4291-CTO 	42T1169	**
11	SATA hard disk drive, 250 GB, 7,200 rpm <ul style="list-style-type: none"> • 4286-CTO • 4287-CTO • 4289-CTO • 4290-CTO • 4291-CTO 	42T1163	**
11	SATA hard disk drive, 250 GB, 7,200 rpm <ul style="list-style-type: none"> • 4286-CTO • 4287-CTO • 4289-CTO • 4290-CTO • 4291-CTO 	42T1173	**
11	SATA hard disk drive, 320 GB, 7,200 rpm <ul style="list-style-type: none"> • 4286-25x, 26x, 28x, 29x • 4287-2Rx, 2Sx, 2Tx, 2Ux • 4290-26x, 3Tx • 4291-28x 	42T1159	**

Table 29. Parts list—Overall (continued)

No.	FRU	FRU no.	CRU ID
11	SATA hard disk drive, 320 GB, 7,200 rpm <ul style="list-style-type: none"> • 4286-25x, 26x, 28x, 29x • 4287-2Rx, 2Sx, 2Tx, 2Ux • 4290-26x, 3Tx • 4291-28x 	42T1171	**
12	Hard disk drive cover assembly	04W1414	**
13	Solid state drive spacers	04W1717	**
14	SATA solid state drive, 128 GB <ul style="list-style-type: none"> • 4286-27x • 4287-2Cx, 2Dx, 2Ex • 4290-2Lx, 2Px, 2Sx, 3Ax 	45N8081	**
14	SATA solid state drive, 128 GB <ul style="list-style-type: none"> • 4286-27x • 4287-2Cx, 2Dx, 2Ex • 4290-2Lx, 2Px, 2Sx, 3Ax 	45N8007	**
14	SATA solid state drive, 128 GB <ul style="list-style-type: none"> • 4286-27x • 4287-2Cx, 2Dx, 2Ex • 4290-2Lx, 2Px, 2Sx, 3Ax 	45N7981	**
14	SATA solid state drive, 160 GB <ul style="list-style-type: none"> • 4287-26x, 27x, 2Jx, 2Qx, 2Vx, 2Xx • 4290-2Ax, 2Cx, 2Mx, 2Nx, 2Tx, 2Ux, 2Vx, 3Bx, 3Fx, 3Sx • 4291-2Dx, 2Qx, 2Vx, 37x 	45N8057	**
15	DVD-ROM drive <ul style="list-style-type: none"> • 4286-CTO • 4287-CTO • 4289-CTO • 4290-CTO • 4291-CTO 	45N7485	**
15	DVD-ROM drive <ul style="list-style-type: none"> • 4286-CTO • 4287-CTO • 4289-CTO • 4290-CTO • 4291-CTO 	45N7521	**

Table 29. Parts list—Overall (continued)

No.	FRU	FRU no.	CRU ID
15	DVD/CD-RW combo drive <ul style="list-style-type: none"> • 4286-27x • 4287-2Gx, 2Jx, 2Kx, 2Lx • 4290-2Hx, 2Sx, 2Tx, 2Ux, 2Vx, 35x, 3Sx • 4291-2Cx, 2Lx, 2Rx, 2Vx, 37x 	45N7457	**
15	DVD/CD-RW combo drive <ul style="list-style-type: none"> • 4286-27x • 4287-2Gx, 2Jx, 2Kx, 2Lx • 4290-2Hx, 2Sx, 2Tx, 2Ux, 2Vx, 35x, 3Sx • 4291-2Cx, 2Lx, 2Rx, 2Vx, 37x 	45N7451	**
15	DVD-RAM/RW combo drive <ul style="list-style-type: none"> • 4286-27x • 4287-2Gx, 2Jx, 2Kx, 2Lx • 4290-2Hx, 2Sx, 2Tx, 2Ux, 2Vx, 35x, 3Sx • 4291-2Cx, 2Lx, 2Rx, 2Vx, 37x 	45N7453	**
16	ThinkPad X220 UltraBase	04W1420	*
16	ThinkPad X220 UltraBase	04W1890	*
17	DIMM door kit	04W1416	**
18	Base cover assembly	04W1421	N
18	Base cover assembly <ul style="list-style-type: none"> • 4286-CTO • 4287-CTO, 26x, 25x, 24x, 23x • 4289-CTO • 4290-CTO, 2Wx, 2Xx, 27x, 26x • 4291-CTO, 2Xx, 2Wx, 26x, 27x 	04W2076	N
19	Fan assembly, SV/LV	04W0435	N
19	Fan assembly, ULV	04W0436	N
20	Speaker kit	04W1412	N
21	Bluetooth daughter card (BDC-2.1) <ul style="list-style-type: none"> • 4286-23x, 24x, 25x, 26x, 27x, 28x, 29x, 2Ax, 2Bx, 2Cx, 2Dx, 2Ex, 2Lx • 4287-22x, 24x, 26x, 27x, 28x, 29x, 2Ax, 2Bx, 2Cx, 2Ex, 2Fx, 2Gx, 2Hx, 2Jx, 2Kx, 2Lx, 2Mx, 2Nx, 2Px, 2Qx, 2Rx, 2Sx, 2Tx, 2Ux, 2Vx, 2Wx, 2Xx, 2Yx, 2Zx, 32x, 33x, 34x, 35x, 36x, 39x, 3Ax, 3Bx • 4290-26x, 27x, 28x, 2Ax, 2Bx, 2Cx, 2Dx, 2Ex, 2Fx, 2Gx, 2Hx, 2Kx, 2Lx, 2Mx, 2Nx, 2Px, 2Qx, 2Rx, 2Sx, 2Tx, 2Ux, 2Vx, 2Wx, 2Yx, 2Zx, 32x, 33x, 35x, 36x, 37x, 38x, 39x, 3Ax, 3Bx, 3Cx, 3Dx, 3Ex, 3Fx, 3Gx, 3Hx, 3Jx, 3Kx, 3Lx, 3Mx, 3Nx, 3Px, 3Qx, 3Rx, 3Sx, 3Tx • 4291-26x, 27x, 28x, 29x, 2Bx, 2Cx, 2Dx, 2Ex, 2Fx, 2Jx, 2Lx, 2Mx, 2Px, 2Qx, 2Rx, 2Sx, 2Tx, 2Ux, 2Vx, 2Wx, 2Xx, 2Yx, 2Zx, 32x, 33x, 34x, 35x, 36x, 37x 	60Y3271	N

Table 29. Parts list—Overall (continued)

No.	FRU	FRU no.	CRU ID
21	<p>Bluetooth daughter card (BDC-2.1)</p> <ul style="list-style-type: none"> 4286-23x, 24x, 25x, 26x, 27x, 28x, 29x, 2Ax, 2Bx, 2Cx, 2Dx, 2Ex, 2Lx 4287-22x, 24x, 26x, 27x, 28x, 29x, 2Ax, 2Bx, 2Cx, 2Ex, 2Fx, 2Gx, 2Hx, 2Jx, 2Kx, 2Lx, 2Mx, 2Nx, 2Px, 2Qx, 2Rx, 2Sx, 2Tx, 2Ux, 2Vx, 2Wx, 2Xx, 2Yx, 2Zx, 32x, 33x, 34x, 35x, 36x, 39x, 3Ax, 3Bx 4290-26x, 27x, 28x, 2Ax, 2Bx, 2Cx, 2Dx, 2Ex, 2Fx, 2Gx, 2Hx, 2Kx, 2Lx, 2Mx, 2Nx, 2Px, 2Qx, 2Rx, 2Sx, 2Tx, 2Ux, 2Vx, 2Wx, 2Yx, 2Zx, 32x, 33x, 35x, 36x, 37x, 38x, 39x, 3Ax, 3Bx, 3Cx, 3Dx, 3Ex, 3Fx, 3Gx, 3Hx, 3Jx, 3Kx, 3Lx, 3Mx, 3Nx, 3Px, 3Qx, 3Rx, 3Sx, 3Tx 4291-26x, 27x, 28x, 29x, 2Bx, 2Cx, 2Dx, 2Ex, 2Fx, 2Jx, 2Lx, 2Mx, 2Px, 2Qx, 2Rx, 2Sx, 2Tx, 2Ux, 2Vx, 2Wx, 2Xx, 2Yx, 2Zx, 32x, 33x, 34x, 35x, 36x, 37x 	60Y3275	N
22	ExpressCard slot	04W1413	N
23	<p>Palm rest assembly with fingerprint reader</p> <ul style="list-style-type: none"> 4286-23x, 24x, 25x, 26x, 27x, 29x, 2Bx, 2Cx, 2Dx, 2Lx 4287-22x, 24x, 26x, 27x, 28x, 29x, 2Bx, 2Cx, 2Ex, 2Fx, 2Gx, 2Hx, 2Jx, 2Kx, 2Lx, 2Mx, 2Nx, 2Px, 2Qx, 2Rx, 2Sx, 2Tx, 2Ux, 2Vx, 2Wx, 2Xx, 2Yx, 2Zx, 32x, 33x, 34x, 35x, 36x, 39x, 3Ax, 3Bx 4289-22x 4290-26x, 27x, 28x, 2Ax, 2Bx, 2Cx, 2Dx, 2Ex, 2Fx, 2Gx, 2Hx, 2Lx, 2Mx, 2Nx, 2Px, 2Ux, 2Vx, 2Wx, 2Yx, 2Zx, 32x, 33x, 35x, 37x, 38x, 3Ax, 3Bx, 3Cx, 3Dx, 3Ex, 3Fx, 3Gx, 3Hx, 3Jx, 3Kx, 3Lx, 3Mx, 3Nx, 3Px, 3Qx, 3Rx, 3Sx, 3Tx 4291-26x, 28x, 29x, 2Bx, 2Cx, 2Dx, 2Ex, 2Fx, 2Jx, 2Lx, 2Mx, 2Px, 2Qx, 2Rx, 2Sx, 2Tx, 2Ux, 2Vx, 2Wx, 2Xx, 2Yx, 2Zx, 32x, 33x, 34x, 35x, 36x, 37x 	04W1410	N
23	<p>Palm rest assembly without fingerprint reader</p> <ul style="list-style-type: none"> 4286-2Ax, 2Ex, 2Fx, 2Gx, 2Hx, 2Jx, 2Kx 4287-2Dx, 37x, 38x 4290-2Jx, 2Xx, 34x, 36x, 39x 4291-27x, 2Gx, 2Hx, 2Kx, 2Nx 	04W1411	N
23	<p>Palm rest assembly with fingerprint reader and mSATA</p> <ul style="list-style-type: none"> 4286-28x 4287-2Ax 4290-2Kx, 2Qx, 2Rx, 2Sx, 2Tx 	04W1770	N
24	Keyboard (see “Keyboard” on page 123.)		
25	TrackPoint stick caps	91P9642	*
26	<p>80GB mSATA</p> <ul style="list-style-type: none"> 4286-28x 4287-2Ax 4290-2Kx, 2Qx, 2Rx, 2Sx, 2Tx 	45N8259	**
—	AC adapter (see “AC adapters” on page 125.)		

LCD FRUs

In ThinkPad X220 and X220i, there are following types of LCDs.

- “12.5-in. HD LED backlight LCD” on page 121

- “12.5-in. HD LED backlight premium LCD” on page 123

12.5-in. HD LED backlight LCD

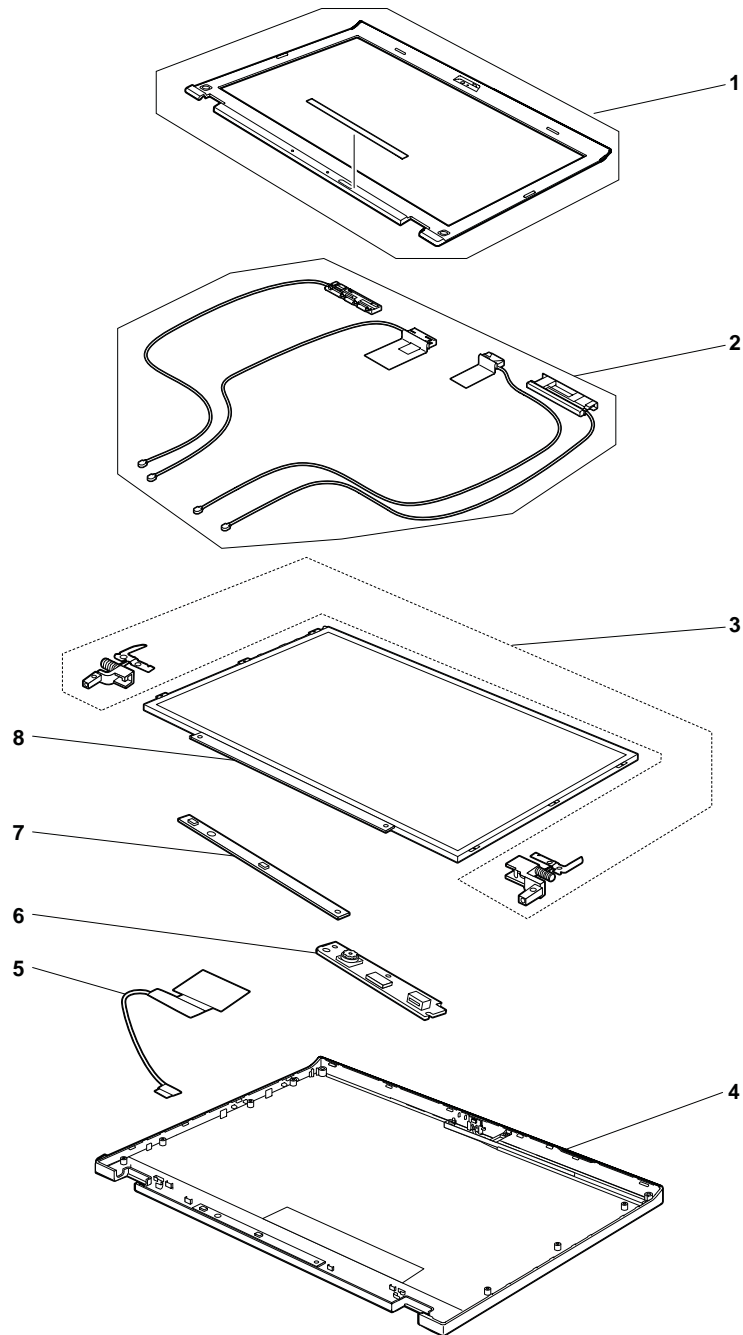

Table 30. Parts list—12.5-in. HD LED backlight LCD

No.	FRU	FRU no.	CRU ID
1	LCD bezel assembly	04W1404	N
2	Wireless LAN/WAN antenna kit	04W1409	N
3	Hinge L/R	04W1407	N

Table 30. Parts list—12.5-in. HD LED backlight LCD (continued)

No.	FRU	FRU no.	CRU ID
4	LCD rear cover assembly	04W1406	N
5	LED-backlight LCD cable assembly	04W1408	N
5	LCD cable assembly	04W1679	N
6	<p>Integrated camera</p> <ul style="list-style-type: none"> • 4286-23x, 24x, 25x, 26x, 28x, 29x, 2Ax, 2Bx, 2Cx, 2Dx, 2Fx, 2Kx, 2Lx • 4287-22x, 24x, 26x, 27x, 28x, 29x, 2Ax, 2Bx, 2Cx, 2Dx, 2Ex, 2Fx, 2Gx, 2Hx, 2Jx, 2Kx, 2Lx, 2Mx, 2Nx, 2Px, 2Qx, 2Rx, 2Sx, 2Tx, 2Ux, 2Vx, 2Wx, 2Xx, 2Yx, 2Zx, 32x, 33x, 34x, 35x, 36x, 37x, 38x, 39x, 3Ax, 3Bx • 4289-22x • 4290-26x, 27x, 28x, 2Ax, 2Bx, 2Cx, 2Dx, 2Ex, 2Fx, 2Hx, 2Jx, 2Kx, 2Lx, 2Mx, 2Nx, 2Px, 2Qx, 2Rx, 2Sx, 2Tx, 2Ux, 2Vx, 2Yx, 32x, 33x, 35x, 36x, 37x, 38x, 39x, 3Bx, 3Cx, 3Dx, 3Ex, 3Fx, 3Gx, 3Hx, 3Jx, 3Kx, 3Lx, 3Mx, 3Nx, 3Px, 3Qx, 3Rx, 3Sx, 3Tx • 4291-26x, 27x, 2Bx, 2Cx, 2Dx, 2Ex, 2Hx, 2Jx, 2Kx, 2Lx, 2Nx, 2Qx, 2Rx, 2Sx, 2Tx, 2Ux, 2Vx, 2Wx, 2Xx, 2Yx, 2Zx, 32x, 33x, 34x, 35x, 36x, 37x 	04W1364	N
7	LED board	04W1422	N
8	<p>LCD panel, 12.5-in. HD LED backlight</p> <ul style="list-style-type: none"> • 4286-23x, 24x, 25x, 26x, 2Ax, 2Bx, 2Kx, 2Cx, 2Dx, 2Ex, 2Fx, 2Gx, 2Hx, 2Jx, 2Lx, • 4287-22x, 2Ax, 34x, 24x, 26x, 27x, 28x, 29x, 2Bx, 2Cx, 2Dx, 2Ex, 2Fx, 2Gx, 2Hx, 2Lx, 2Mx, 2Nx, 2Rx, 2Sx, 2Tx, 2Ux, 2Yx, 2Zx, 32x, 33x, 35x, 36x, 37x, 38x, 39x, 3Bx • 4289-22x • 4290-2Kx, 2Qx, 2Rx, 2Sx, 2Tx, 3Ex, 3Jx, 26x, 27x, 28x, 2Ax, 2Bx, 2Cx, 2Dx, 2Ex, 2Fx, 2Gx, 2Jx, 2Lx, 2Mx, 2Nx, 2Px, 2Ux, 2Vx, 2Wx, 2Xx, 33x, 34x, 35x, 36x, 37x, 38x, 39x, 3Ax, 3Bx, 3Cx, 3Hx, 3Mx, 3Nx, 3Px, 3Qx, 3Rx, 3Sx, 3Tx • 4291-26x, 27x, 28x, 29x, 2Bx, 2Cx, 2Dx, 2Ex, 2Fx, 2Gx, 2Jx, 2Kx, 2Px, 2Qx, 2Rx, 2Sx, 2Tx, 2Ux, 2Vx, 2Wx, 2Xx, 2Yx, 2Zx, 32x, 33x, 35x, 36x, 37x 	93P5669	N
8	<p>LCD panel, 12.5-in. WXGA, LED backlight</p> <ul style="list-style-type: none"> • 4286-23x, 24x, 25x, 26x, 2Ax, 2Bx, 2Kx, 2Cx, 2Dx, 2Ex, 2Fx, 2Gx, 2Hx, 2Jx, 2Lx, • 4287-22x, 2Ax, 34x, 24x, 26x, 27x, 28x, 29x, 2Bx, 2Cx, 2Dx, 2Ex, 2Fx, 2Gx, 2Hx, 2Lx, 2Mx, 2Nx, 2Rx, 2Sx, 2Tx, 2Ux, 2Yx, 2Zx, 32x, 33x, 35x, 36x, 37x, 38x, 39x, 3Bx • 4289-22x • 4290-2Kx, 2Qx, 2Rx, 2Sx, 2Tx, 3Ex, 3Jx, 26x, 27x, 28x, 2Ax, 2Bx, 2Cx, 2Dx, 2Ex, 2Fx, 2Gx, 2Jx, 2Lx, 2Mx, 2Nx, 2Px, 2Ux, 2Vx, 2Wx, 2Xx, 33x, 34x, 35x, 36x, 37x, 38x, 39x, 3Ax, 3Bx, 3Cx, 3Hx, 3Mx, 3Nx, 3Px, 3Qx, 3Rx, 3Sx, 3Tx • 4291-26x, 27x, 28x, 29x, 2Bx, 2Cx, 2Dx, 2Ex, 2Fx, 2Gx, 2Jx, 2Kx, 2Px, 2Qx, 2Rx, 2Sx, 2Tx, 2Ux, 2Vx, 2Wx, 2Xx, 2Yx, 2Zx, 32x, 33x, 35x, 36x, 37x 	93P5671	N
8	<p>LCD panel, 12.5-in. WXGA, LED backlight</p> <ul style="list-style-type: none"> • 4286-23x, 24x, 25x, 26x, 2Ax, 2Bx, 2Kx, 2Cx, 2Dx, 2Ex, 2Fx, 2Gx, 2Hx, 2Jx, 2Lx, • 4287-22x, 2Ax, 34x, 24x, 26x, 27x, 28x, 29x, 2Bx, 2Cx, 2Dx, 2Ex, 2Fx, 2Gx, 2Hx, 2Lx, 2Mx, 2Nx, 2Rx, 2Sx, 2Tx, 2Ux, 2Yx, 2Zx, 32x, 33x, 35x, 36x, 37x, 38x, 39x, 3Bx • 4289-22x • 4290-2Kx, 2Qx, 2Rx, 2Sx, 2Tx, 3Ex, 3Jx, 26x, 27x, 28x, 2Ax, 2Bx, 2Cx, 2Dx, 2Ex, 2Fx, 2Gx, 2Jx, 2Lx, 2Mx, 2Nx, 2Px, 2Ux, 2Vx, 2Wx, 2Xx, 33x, 34x, 35x, 36x, 37x, 38x, 39x, 3Ax, 3Bx, 3Cx, 3Hx, 3Mx, 3Nx, 3Px, 3Qx, 3Rx, 3Sx, 3Tx • 4291-26x, 27x, 28x, 29x, 2Bx, 2Cx, 2Dx, 2Ex, 2Fx, 2Gx, 2Jx, 2Kx, 2Px, 2Qx, 2Rx, 2Sx, 2Tx, 2Ux, 2Vx, 2Wx, 2Xx, 2Yx, 2Zx, 32x, 33x, 35x, 36x, 37x 	93P5673	N

12.5-in. HD LED backlight premium LCD

Table 31. Parts list—12.5-in. HD LED backlight premium LCD

No.	FRU	FRU no.	CRU ID
1	LCD bezel assembly	04W1404	N
2	Wireless LAN/WAN antenna kit	04W1409	N
3	Hinge L/R	04W1407	N
4	LCD rear cover assembly	04W1406	N
5	LED-backlight LCD cable assembly	04W1408	N
5	LCD cable assembly	04W1679	N
6	Integrated camera <ul style="list-style-type: none"> • 4286-23x, 24x, 25x, 26x, 28x, 29x, 2Ax, 2Bx, 2Cx, 2Dx, 2Fx, 2Kx, 2Lx • 4287-22x, 24x, 26x, 27x, 28x, 29x, 2Ax, 2Bx, 2Cx, 2Dx, 2Ex, 2Fx, 2Gx, 2Hx, 2Jx, 2Kx, 2Lx, 2Mx, 2Nx, 2Px, 2Qx, 2Rx, 2Sx, 2Tx, 2Ux, 2Vx, 2Wx, 2Xx, 2Yx, 2Zx, 32x, 33x, 34x, 35x, 36x, 37x, 38x, 39x, 3Ax, 3Bx • 4289-22x • 4290-26x, 27x, 28x, 2Ax, 2Bx, 2Cx, 2Dx, 2Ex, 2Fx, 2Hx, 2Jx, 2Kx, 2Lx, 2Mx, 2Nx, 2Px, 2Qx, 2Rx, 2Sx, 2Tx, 2Ux, 2Vx, 2Yx, 32x, 33x, 35x, 36x, 37x, 38x, 39x, 3Bx, 3Cx, 3Dx, 3Ex, 3Fx, 3Gx, 3Hx, 3Jx, 3Kx, 3Lx, 3Mx, 3Nx, 3Px, 3Qx, 3Rx, 3Sx, 3Tx • 4291-26x, 27x, 2Bx, 2Cx, 2Dx, 2Ex, 2Hx, 2Jx, 2Kx, 2Lx, 2Nx, 2Qx, 2Rx, 2Sx, 2Tx, 2Ux, 2Vx, 2Wx, 2Xx, 2Yx, 2Zx, 32x, 33x, 34x, 35x, 36x, 37x 	04W1364	N
7	LED board	04W1422	N
8	LCD panel, 12.5-in. HD LED backlight premium <ul style="list-style-type: none"> • 4286-27x, 28x, 29x • 4287-2Jx, 2Kx, 2Px, 2Qx, 2Vx, 2Wx, 2Xx, 3Ax • 4290-2Hx, 2Yx, 2Zx, 32x, 3Dx, 3Fx, 3Gx, 3Kx, 3Lx • 4291-2Hx, 2Lx, 2Mx, 2Nx, 34x 	93P5675	N

Keyboard

Table 32. Parts list—Keyboard

Language	P/N			CRU ID
Arabic	45N2216	45N2076	45N2146	**
Belgian	45N2217	45N2077	45N2147	
Brazilian Portuguese	45N2215	45N2075	45N2145	
Bulgarian	45N2218	45N2078	45N2148	
Canadian French (058)	45N2213	45N2073	45N2143	
Canadian French (Acnor)	45N2212	45N2072	45N2142	
Czech	45N2219	45N2079	45N2149	
Danish	45N2220	45N2080	45N2150	
Dutch	45N2230	45N2090	45N2160	
French	45N2222	45N2082	45N2152	
German	45N2223	45N2083	45N2153	

Table 32. Parts list—Keyboard (continued)

Language	P/N			CRU ID
Greek (U.S. English and Greek layout)	45N2224	45N2084	45N2154	
Hungarian	45N2226	45N2086	45N2156	
Icelandic	45N2227	45N2087	45N2157	
Israel (Hebrew)	45N2225	45N2085	45N2155	
Italian	45N2228	45N2088	45N2158	
Japanese	45N2242	45N2102	45N2172	
Kazakhstan	45N2229	45N2089	45N2159	
Korean	45N2243	45N2103	45N2173	
Latin American Spanish	45N2214	45N2074	45N2144	
Norwegian	45N2231	45N2091	45N2161	
Polish	45N2232	45N2092	45N2162	
Portuguese	45N2233	45N2093	45N2163	
Russian	45N2234	45N2094	45N2164	
Slovak	45N2235	45N2095	45N2165	
Slovenian	45N2236	45N2096	45N2166	
Swedish, Finnish	45N2237	45N2097	45N2167	
Spanish	45N2221	45N2081	45N2151	
Swiss	45N2238	45N2098	45N2168	
Thai	45N2245	45N2105	45N2175	
Traditional Chinese	45N2244	45N2104	45N2174	
Turkish	45N2239	45N2099	45N2169	
Turkish (F Type)	60Y9550	60Y9552	60Y9554	
U.K. English	45N2240	45N2100	45N2170	
U.S. English	45N2211	45N2071	45N2141	
U.S. English (International, with a Euro symbol)	45N2241	45N2101	45N2171	

Miscellaneous parts

Table 33. Parts list—Miscellaneous parts

FRU	P/N	CRU ID
Screw kit <ul style="list-style-type: none"> • Screw M2 x 5 mm, (13) • Screw M2 x 3.5 mm, Silver, (40) • Screw M2 x 2 mm, (2) • Screw M2 x 3.5 mm, (2) • Hex nut washer, (2) • Screw M2.5 x 4.5 mm, (2) • Screw M3 x 3.5 mm, (1) • Screw IMS 2 x 5 mm, (12) • Screw cap circle, (2) 	04W1419	N
Base cover miscellaneous parts kit <ul style="list-style-type: none"> • Battery Latch left • Battery Latch right • Battery Latch spring • Battery knob, (2) • Front rubber foot, (2) • Rear rubber foot, (2) • Base cover bracket • DC-in cable bracket 	04W1417	N
System miscellaneous parts kit <ul style="list-style-type: none"> • RUB MIC LDB-1, (2) • CPU support bracket assy 	04W1418	N
Rubber kit	04W1415	N

AC adapters

Table 34. Parts list—AC adapters

FRU	P/N	CRU ID
2-pin (65 W, 20 V) adapter (models CTO, xxE, xxF, xxJ, xxL, xxP, xxS, xxY, xxU)	42T5282	*
2-pin (65 W, 20 V) adapter (models CTO, xxE, xxF, xxJ, xxL, xxP, xxS, xxY, xxU)	42T4419	
2-pin (65 W, 20 V) adapter (models CTO, xxE, xxF, xxJ, xxL, xxP, xxS, xxY, xxU)	42T4423	
3-pin (65W, 20 V) adapter (models CTO, xxA, xxB, xxC, xxG, xxH, xxK, xxM, xxT, xxV) OP	42T5283	
3-pin (65W, 20 V) adapter (models CTO, xxA, xxB, xxC, xxG, xxH, xxK, xxM, xxT, xxV) OP	42T4417	
3-pin (65W, 20 V) adapter (models CTO, xxA, xxB, xxC, xxG, xxH, xxK, xxM, xxT, xxV) OP	42T4421	

Power cords

A ThinkPad power cord for a specific country or region is usually available only in that country or region:

Table 35. Parts list—2-pin power cords

Country or region	FRU no.		CRU ID
Argentina • models -CTO, xxY	42T5020	42T5105	*
Brazil • models -CTO, xxP	42T5180	42T5183	
Canada, U.S. • models -CTO, xxF, xxL, xxS, xxU	42T5008	42T5093	
Japan • models -CTO, xxE, xxJ	42T5014	42T5099	

Table 36. Parts list—3-pin power cords

Country or region	FRU no.		CRU ID
Australia, New Zealand • models -CTO, xxM	42T5050	42T5135	*
Bangladesh, Sri Lanka, South Africa • models -CTO, xxG	42T5056	42T5141	
Canada, U.S. • models -CTO, xxG, xxT	42T5004	42T5089	
China (P.R.C.) (other than Hong Kong S.A.R.) • models -CTO, xxC	42T5065	42T5150	
Denmark • models -CTO, xxG	42T5041	42T5126	
European countries • models -CTO, xxG	42T5029	42T5114	
India • models -CTO, xxQ	42T5083	42T5168	
Israel • models -CTO, xxG	42T5062	42T5147	
Italy • models -CTO, xxG	42T5047	42T5132	
Korea • models -CTO, xxK	42T5077	42T5162	
Switzerland • models -CTO, xxG	42T5044	42T5129	
Taiwan • models -CTO, xxV	42T5071	42T5156	
U.K., China (Hong Kong S.A.R.) • models -CTO, xxB, xxG, xxH	42T5035	42T5120	

Recovery discs

Windows XP Professional (32 bit) DVDs

Windows XP Professional (32 bit) is preinstalled as the operating system in the following models:

- 4286-CTO
- 4287-CTO
- 4289-CTO
- 4290-CTO
- 4291-CTO

Table 37. Parts list—Windows XP Professional (32 bit) recovery DVDs

Language	P/N	CRU ID
Japanese	03W8394	*
English	03W8395	

Windows XP Professional Generic (32bit) DVDs

- 4286-CTO
- 4287-CTO
- 4289-CTO
- 4290-CTO
- 4291-CTO

Table 38. Parts list—Windows XP Professional Generic (32 bit) recovery DVDs

Language	P/N	CRU ID
Brazilian Portuguese	03W7476	*
Czech	03W7479	
Danish	03W7480	
Dutch	03W7490	
Finnish	03W7481	
French	03W7482	
German	03W7484	
Greek	03W7483	
Hungarian	03W7486	
Italian	03W7487	
Korean	03W7489	
Norwegian	03W7491	
Polish	03W7492	
Portuguese	03W7493	
Russian	03W7494	
Simplified Chinese	03W7477	
Spanish	03W7495	
Swedish	03W7496	
Traditional Chinese	03W7478	
Traditional Chinese (Hong Kong S.A.R.)	03W7485	

Table 38. Parts list—Windows XP Professional Generic (32 bit) recovery DVDs (continued)

Language	P/N	CRU ID
Turkish	03W7497	

Windows XP Tablet (32 bit) DVDs

- 4286-CTO
- 4287-CTO
- 4289-CTO
- 4290-CTO
- 4291-CTO

Table 39. Parts list—Windows XP Tablet (32 bit) recovery DVDs

Language	P/N	CRU ID
English	04X0000	*
Japanese	03W8396	

Windows Vista Business (32 bit) DVDs

Windows Vista Business (32 bit) is preinstalled as the operating system in the following models:

- 4286-CTO
- 4287-CTO
- 4289-CTO
- 4290-CTO
- 4291-CTO

Table 40. Parts list—Windows Vista Business (32 bit) recovery DVDs

Language	P/N	CRU ID
English	03W8398	*
Japanese	03W8397	

Windows Vista Home Basic (32 bit) DVDs

- 4286-CTO
- 4287-CTO
- 4289-CTO
- 4290-CTO
- 4291-CTO

Table 41. Parts list—Windows Vista Home Basic (32 bit) recovery DVDs

Language	P/N	CRU ID
English	03W8399	*

Windows 7 Professional (32 bit) DVDs

Windows 7 Professional (32 bit) is preinstalled as the operating system in the following models:

- 4287-34x

Table 42. Parts list—Windows 7 Professional (32 bit) recovery DVDs

Language	P/N	CRU ID
English	04X0002	*
Japanese	04X0001	
Simplified Chinese	03W8400	

Windows 7 Ultimate (32 bit) DVDs

- 4286-CTO
- 4287-CTO
- 4289-CTO
- 4290-CTO
- 4291-CTO

Table 43. Parts list—Windows 7 Ultimate (32 bit) recovery DVDs

Language	P/N	CRU ID
English	04X0003	*

Windows 7 Professional (64 bit) DVDs

Windows 7 Professional (64 bit) is preinstalled as the operating system in the following models:

- 4286-24x, 27x, 28x, 29x, 2Ax, 2Kx, 2Lx
- 4287-26x, 27x, 28x, 29x, 2Ax, 2Bx, 2Cx, 2Gx, 2Hx, 2Jx, 2Kx, 2Lx, 2Mx, 2Nx, 2Px, 2Qx, 2Sx, 2Vx, 2Wx, 2Xx, 2Zx, 32x, 33x, 35x, 38x, 39x, 3Ax, 3Bx
- 4290-26x, 28x, 2Ax, 2Bx, 2Cx, 2Dx, 2Ex, 2Fx, 2Gx, 2Hx, 2Jx, 2Kx, 2Lx, 2Mx, 2Nx, 2Px, 2Qx, 2Rx, 2Sx, 2Tx, 2Ux, 2Vx, 2Wx, 2Xx, 2Yx, 2Zx, 32x, 33x, 34x, 35x, 37x, 38x, 39x, 3Ax, 3Bx, 3Cx, 3Dx, 3Fx, 3Gx, 3Hx, 3Jx, 3Kx, 3Lx, 3Nx, 3Px, 3Qx, 3Sx, 3Tx
- 4291-26x, 27x, 28x, 29x, 2Bx, 2Cx, 2Dx, 2Ex, 2Fx, 2Gx, 2Hx, 2Jx, 2Kx, 2Lx, 2Mx, 2Nx, 2Px, 2Qx, 2Rx, 2Sx, 2Tx, 2Ux, 2Vx, 2Wx, 2Xx, 2Zx, 32x, 33x, 34x, 35x, 37x

Table 44. Parts list—Windows 7 Professional (64 bit) recovery DVDs

Language	P/N	CRU ID
Arabic	04X0004	*
Brazilian Portuguese	04X0005	
Czech	04X0008	
English, Danish, Finnish, Swedish, and Norwegian	04X0028	
English, Dutch, French, German, and Italian	04X0029	
English, Slovenian, and Croatian	04X0030	

Table 44. Parts list—Windows 7 Professional (64 bit) recovery DVDs (continued)

Language	P/N	CRU ID
French	04X0010	
German	04X0012	
Greek	04X0011	
Hebrew	04X0013	
Hungarian	04X0015	
Indian English	04X0009	
Japanese	04X0016	
Korean /English	04X0017	
Polish	04X0018	
Portuguese	04X0019	
Romanian	04X0020	
Russian	04X0021	
Serbian-Latin	04X0024	
Simplified Chinese	04X0006	
Slovakian	04X0022	
Spanish	04X0023	
Traditional Chinese	04X0007	
Traditional Chinese (Hong Kong S.A.R.)	04X0014	
Turkish	04X0025	
US English	04X0027	
US English (Disabled)	04X0026	

Windows 7 Ultimate (64 bit) DVDs

- 4286-CTO
- 4287-CTO
- 4289-CTO
- 4290-CTO
- 4291-CTO

Table 45. Parts list—Windows 7 Ultimate (64 bit) recovery DVDs

Language	P/N	CRU ID
English	04X0031	*

Windows 7 Home Basic (32 bit) DVDs

Windows 7 Home Basic (32 bit) is preinstalled as the operating system in the following models:

- 4286-23x, 2Bx, 2Cx, 2Dx, 2Ex, 2Fx, 2Gx, 2Hx, 2Jx
- 4287-24x, 2Dx, 2Ex, 2Fx, 36x, 37x

Table 46. Parts list—Windows 7 Home Basic (32 bit) DVDs

Language	P/N	CRU ID
Arabic	04X0032	*
Brazilian Portuguese	04X0033	
English	04X0042	
English (for India)	04X0035	
French	04X0036	
Portuguese	04X0037	
Russian	04X0038	
Serbian-Latin	04X0041	
Simplified Chinese	04X0034	
Spanish	04X0039	
Turkish	04X0041	

Windows 7 Home Premium (32 bit) DVDs

- 4286-CTO
- 4287-CTO
- 4289-CTO
- 4290-CTO
- 4291-CTO

Table 47. Parts list—Windows Home Premium (32 bit) recovery DVDs

Language	P/N	CRU ID
English	04X0045	*
English (for India)	04X0044	
Simplified Chinese	04X0043	

Windows 7 Home Premium (64 bit) DVDs

Windows 7 Home Premium (64 bit) is preinstalled as the operating system in the following models:

- 4287-22x, 2Yx
- 4290-36x, 3Ex
- 4291-36x

Table 48. Parts list—Windows 7 Home Premium (64 bit) recovery DVDs

Language	P/N	CRU ID
Arabic	04X0046	*
Brazilian Portuguese	04X0047	
Czech	04X0050	
English, Danish, Finnish, Swedish, and Norwegian	0A47089	
English, Dutch, French, German, and Italian	0A47090	
English, Slovenian, and Croatian	0A47091	
French	04X0051	
German	04X0053	
Greek	04X0052	
Hebrew	04X0054	
Hungarian	04X0056	
Japanese	04X0057	
Korean /English	04X0058	
Polish	04X0059	
Portuguese	04X0060	
Romanian	04X0061	
Russian	04X0062	
Serbian-Latin	04X0065	
Simplified Chinese	04X0048	
Slovakian	04X0063	
Spanish	04X0064	
Traditional Chinese	04X0049	
Traditional Chinese (Hong Kong S.A.R.)	04X0055	
Turkish	04X0066	
US English	04X0068	
US English (Disabled)	04X0067	

Common service tools

Table 49. Parts list—Common service tools

Tool	P/N
Screwdriver kit	95F3598
1/4" drive spinner handle	1650840
1/4" Sq. to 1/4" hex torx adapter	93F2838
TR7-TR-10 tamper resistant torx bits	00P6967
Removal tool antenna RF connector	08K7159
USB 2.0 CD-RW/DVD-ROM combo drive II	40Y8687
USB cable	40Y8704

Table 49. Parts list—Common service tools (continued)

Tool	P/N
USB floppy diskette drive for maintenance diskette	05K9283
USB floppy diskette drive tool kit	27L3452
Test card for integrated Smart Card	42W7820
ThinkPad Hardware Maintenance Diskette Version 1.73 or later Note: Download the file from the following Web site: http://www.lenovo.com/spm	—

Appendix A. Notices

Lenovo may not offer the products, services, or features discussed in this document in all countries. Consult your local Lenovo representative for information on the products and services currently available in your area. Any reference to a Lenovo product, program, or service is not intended to state or imply that only that Lenovo product, program, or service may be used. Any functionally equivalent product, program, or service that does not infringe any Lenovo intellectual property right may be used instead. However, it is the user's responsibility to evaluate and verify the operation of any other product, program, or service.

Lenovo may have patents or pending patent applications covering subject matter described in this document. The furnishing of this document does not give you any license to these patents. You can send license inquiries, in writing, to:

*Lenovo (United States), Inc.
1009 Think Place - Building One
Morrisville, NC 27560
U.S.A.
Attention: Lenovo Director of Licensing*

LENOVO PROVIDES THIS PUBLICATION "AS IS" WITHOUT WARRANTY OF ANY KIND, EITHER EXPRESS OR IMPLIED, INCLUDING, BUT NOT LIMITED TO, THE IMPLIED WARRANTIES OF NON-INFRINGEMENT, MERCHANTABILITY OR FITNESS FOR A PARTICULAR PURPOSE. Some jurisdictions do not allow disclaimer of express or implied warranties in certain transactions, therefore, this statement may not apply to you.

This information could include technical inaccuracies or typographical errors. Changes are periodically made to the information herein; these changes will be incorporated in new editions of the publication. Lenovo may make improvements and/or changes in the product(s) and/or the program(s) described in this publication at any time without notice.

The products described in this document are not intended for use in implantation or other life support applications where malfunction may result in injury or death to persons. The information contained in this document does not affect or change Lenovo product specifications or warranties. Nothing in this document shall operate as an express or implied license or indemnity under the intellectual property rights of Lenovo or third parties. All information contained in this document was obtained in specific environments and is presented as an illustration. The result obtained in other operating environments may vary.

Lenovo may use or distribute any of the information you supply in any way it believes appropriate without incurring any obligation to you.

Any references in this publication to non-Lenovo Web sites are provided for convenience only and do not in any manner serve as an endorsement of those Web sites. The materials at those Web sites are not part of the materials for this Lenovo product, and use of those Web sites is at your own risk.

Any performance data contained herein was determined in a controlled environment. Therefore, the result obtained in other operating environments may vary significantly. Some measurements may have been made on development-level systems and there is no guarantee that these measurements will be the same on generally available systems. Furthermore, some measurements may have been estimated through extrapolation. Actual results may vary. Users of this document should verify the applicable data for their specific environment.

Electronic emissions notices

For electronic emission information on Class B digital devices, refer to the corresponding information in the *User Guide*.



Trademarks

The following terms are trademarks of Lenovo in the United States, other countries or both:

- Active Protection System
- Lenovo
- Rescue and Recovery
- ThinkLight
- ThinkPad
- ThinkVantage
- TrackPoint
- UltraBase
- Ultrabay
- UltraNac

The following terms are trademarks of the International Business Machines Corporation in the United States, other countries, or both:

- IBM (used under license)

The following terms are trademarks of Microsoft Corporation in the United States, other countries, or both:

- Windows
- Windows Vista

The following are trademarks of Intel Corporation or its subsidiaries in the United States, other countries, or both:

- Intel
- Intel Celeron
- Intel Celeron M
- Intel Core 2 Duo
- Intel Core 2 Solo

Other company, product, or service names may be the trademarks or service marks of others.

ThinkPad®

Part Number: 0A60739

Printed in China

(1P) P/N: 0A60739

