

TH-15A

2-Way 15" Powered Loudspeaker

OWNER'S MANUAL



MACKIE®

Important Safety Instructions

1. Read these instructions.
2. Keep these instructions.
3. Heed all warnings.
4. Follow all instructions.
5. Do not use this apparatus near water.
6. Clean only with a dry cloth.
7. Do not block any ventilation openings. Install in accordance with the manufacturer's instructions.
8. Do not install near any heat sources such as radiators, heat registers, stoves, or other apparatus (including amplifiers) that produce heat.
9. Do not defeat the safety purpose of the polarized or grounding-type plug. A polarized plug has two blades with one wider than the other. A grounding-type plug has two blades and a third grounding prong. The wide blade or the third prong are provided for your safety. If the provided plug does not fit into your outlet, consult an electrician for replacement of the obsolete outlet.
10. Protect the power cord from being walked on or pinched particularly at plugs, convenience receptacles, and the point where they exit from the apparatus.
11. Only use attachments/accessories specified by the manufacturer.
12. Use only with a cart, stand, tripod, bracket, or table specified by the manufacturer, or sold with the apparatus. When a cart is used, use caution when moving the cart/apparatus combination to avoid injury from tip-over.
13. Unplug this apparatus during lightning storms or when unused for long periods of time.
14. Refer all servicing to qualified service personnel. Servicing is required when the apparatus has been damaged in any way, such as power-supply cord or plug is damaged, liquid has been spilled or objects have fallen into the apparatus, the apparatus has been exposed to rain or moisture, does not operate normally, or has been dropped.
15. This apparatus shall not be exposed to dripping or splashing, and no object filled with liquids, such as vases or beer glasses, shall be placed on the apparatus.
16. Do not overload wall outlets and extension cords as this can result in a risk of fire or electric shock.
17. This apparatus has been designed with Class-I construction and must be connected to a mains socket outlet with a protective earthing connection (the third grounding prong).
18. This apparatus has been equipped with a rocker-style AC mains power switch. This switch is located on the rear panel and should remain readily accessible to the user.
19. The MAINS plug or an appliance coupler is used as the disconnect device, so the disconnect device shall remain readily operable.



20. NOTE: This equipment has been tested and found to comply with the limits for a Class B digital device, pursuant to part 15 of the FCC Rules. These limits are designed to provide reasonable protection against harmful interference in a residential installation. This equipment generates, uses, and can radiate radio frequency energy and, if not installed and used in accordance with the instructions, may cause harmful interference to radio communications. However, there is no guarantee that interference will not occur in a particular installation. If this equipment does cause harmful interference to radio or television reception, which can be determined by turning the equipment off and on, the user is encouraged to try to correct the interference by one or more of the following measures:
- Reorient or relocate the receiving antenna.
 - Increase the separation between the equipment and the receiver.
 - Connect the equipment into an outlet on a circuit different from that to which the receiver is connected.
 - Consult the dealer or an experienced radio/TV technician for help.

CAUTION: Changes or modifications to this device not expressly approved by LOUD Technologies Inc. could void the user's authority to operate the equipment under FCC rules.

21. This apparatus does not exceed the Class A/Class B (whichever is applicable) limits for radio noise emissions from digital apparatus as set out in the radio interference regulations of the Canadian Department of Communications.

ATTENTION — *Le présent appareil numérique n'émet pas de bruits radioélectriques dépassant les limites applicables aux appareils numériques de class A/de class B (selon le cas) prescrites dans le règlement sur le brouillage radioélectrique édicté par les ministere des communications du Canada.*

22. Exposure to extremely high noise levels may cause permanent hearing loss. Individuals vary considerably in susceptibility to noise-induced hearing loss, but nearly everyone will lose some hearing if exposed to sufficiently intense noise for a period of time. The U.S. Government's Occupational Safety and Health Administration (OSHA) has specified the permissible noise level exposures shown in the following chart. According to OSHA, any exposure in excess of these permissible limits could result in some hearing loss. To ensure against potentially dangerous exposure to high sound pressure levels, it is recommended that all persons exposed to equipment capable of producing high sound pressure levels use hearing protectors while the equipment is in operation. Ear plugs or protectors in the ear canals or over the ears must be worn when operating the equipment in order to prevent permanent hearing loss if exposure is in excess of the limits set forth here:

| | | |
|---|---------------------|--|
| | CAUTION AVIS | |
| RISK OF ELECTRIC SHOCK. DO NOT OPEN RISQUE DE CHOC ELECTRIQUE. NE PAS OUVRIR | | |
| CAUTION: TO REDUCE THE RISK OF ELECTRIC SHOCK DO NOT REMOVE COVER (OR BACK) NO USER-SERVICEABLE PARTS INSIDE. REFER SERVICING TO QUALIFIED PERSONNEL ATTENTION: POUR EVITER LES RISQUES DE CHOC ELECTRIQUE, NE PAS ENLEVER LE COUVERCLE. AUCUN ENTRETIEN DE PIECES INTERIEURES PAR L'USAGER. CONFIER L'ENTRETIEN AU PERSONNEL QUALIFIE. AVIS: POUR EVITER LES RISQUES D'INCENDIE OU D'ELECTROCUTION, N'EXPOSEZ PAS CET ARTICLE A LA PLUIE OU A L'HUMIDITE | | |

The lightning flash with arrowhead symbol within an equilateral triangle is intended to alert the user to the presence of uninsulated "dangerous voltage" within the product's enclosure, that may be of sufficient magnitude to constitute a risk of electric shock to persons.
Le symbole éclair avec point de flèche à l'intérieur d'un triangle équilatéral est utilisé pour alerter l'utilisateur de la présence à l'intérieur du coffret de "voltage dangereux" non isolé d'ampleur suffisante pour constituer un risque d'électrocution.

The exclamation point within an equilateral triangle is intended to alert the user of the presence of important operating and maintenance (servicing) instructions in the literature accompanying the appliance.
Le point d'exclamation à l'intérieur d'un triangle équilatéral est employé pour alerter les utilisateurs de la présence d'instructions importantes pour fonctionnement et l'entretien (service) dans le livret d'instruction accompagnant l'appareil.

| Duration, per day in hours | Sound Level dBA, Slow Response | Typical Example |
|----------------------------|--------------------------------|--|
| 8 | 90 | Duo in small club |
| 6 | 92 | |
| 4 | 95 | Subway Train |
| 3 | 97 | |
| 2 | 100 | Very loud classical music |
| 1.5 | 102 | |
| 1 | 105 | Greg and Ben screaming at Troy about deadlines |
| 0.5 | 110 | |
| 0.25 or less | 115 | Loudest parts at a rock concert |

WARNING — To reduce the risk of fire or electric shock, do not expose this apparatus to rain or moisture.

CONTENTS

- SAFETY INSTRUCTIONS 2
- INTRODUCTION 5
- HOOKUP DIAGRAMS..... 5
- MACKIE TH-15A FEATURES 8
 - REAR PANEL DESCRIPTION 8
 - 1. INPUT 8
 - 2. THRU 8
 - 3. LEVEL 8
 - 4. OL INDICATOR..... 9
 - 5. HIGH EQ 9
 - 6. MID EQ 9
 - 7. MID FREQ 9
 - 8. LOW EQ 9
 - 9. EQ ON/OFF SWITCH 9
 - 10. POWER SWITCH 9
 - 11. LINE CORD SOCKET AND FUSE..... 9
- PROTECTION CIRCUITS..... 10
- INPUT SIGNAL WIRING 10
- PLACEMENT 10
- APPENDIX A: SERVICE INFORMATION..... 11
- APPENDIX B: CONNECTIONS 12
- APPENDIX C: TH-15A SPECIFICATIONS..... 13
- TH-15A DIMENSIONS..... 14
- TH-15A FREQUENCY GRAPH 14
- TH-15A BLOCK DIAGRAM 15
- MACKIE LIMITED WARRANTY 16

What? Me read a manual?

Before you begin, please make sure you read the Safety Instructions on page 2 and Getting Started on page 4.

Your new Mackie TH-15A powered loudspeakers are designed to set up quickly and operate easily. We know it's often seen as a sign of weakness to read a manual, along with asking for directions when lost, but we hope you will read the rest of the manual, at least while nobody is looking.

It is important to keep your receipt in a safe place, and not a bad idea to write your product information below for future reference (i.e., insurance claims, tech support, return authorization, etc.).



Please write the serial number for your TH-15A here (or for both TH-15As if you have two) for future reference (i.e., insurance claims, tech support, return authorization, etc.):

Loudspeaker 1

Loudspeaker 2

Purchased at: _____ **Date of Purchase:** _____

Don't forget to visit our website at www.mackie.com for more information about this and other Mackie products.

Getting Started

The following steps will help you set up your loudspeakers quickly.

INITIAL SETTINGS:

1. Turn the LEVEL control on the rear panel all the way down.
2. Set the EQ ON/OFF switch out (OFF).
3. Turn the POWER switch OFF.

CONNECTIONS:

1. Connect the line-level signal from your mixer (or other signal source) to the INPUT jack on the TH-15A rear panel (XLR connector).
2. Connect the supplied AC power cord to the IEC socket on the back of the loudspeaker. Plug the other end into an AC outlet properly configured with the correct voltage as indicated just below the IEC socket.

TURN IT ON:

1. Turn the POWER switch ON.
2. Start your signal source (mp3 player, CD, DAW, band, or whatever), but leave the master level control on your mixer down.
3. Slowly turn up the LEVEL control on the TH-15A to the “U” (unity gain) mark at the center position.
4. Adjust the master volume on your mixer to a comfortably loud listening level. If the volume from the speakers gets really loud, really fast, try turning down the LEVEL control on the TH-15A a bit. If the speakers don't get loud enough, turn up the LEVEL control to achieve a good balance of master volume control and loudness from the speaker.

Now that you have your loudspeakers working, it's time to hunker down and read the rest of this manual... especially the following:

ADDITIONAL TIDBITS OF WISDOM:

- Never listen to loud music for prolonged periods. Please see the Safety Instructions on page 2 for information on hearing protection.
- When you shut down your equipment, turn off the TH-15A loudspeakers first to prevent thumps and other noises generated by any upstream equipment from coming out the speakers. When powering up, turn on the TH-15As last.
- Save the shipping boxes and packing materials! You may need them someday. Besides, your cat will love playing in them and jumping out at you unexpectedly. Remember to pretend like you are surprised!
- Save your sales receipt in a safe place.
- Record the serial number in the space provided on page 3, along with where and when you bought it.

Introduction

The Mackie TH-15A Powered Loudspeaker delivers a chest-pounding 400W of peak system power via ultra-efficient Class-D amplification. This means more power with less weight, perfect when portability matters. The 15” high-precision woofer provides punchy low-end and responds quickly to transients. Hey, it’s called a THUMP, right?

An integrated 3-band contour EQ with a sweepable mid-frequency lets you dial in the perfect tone for your application and even allows you to correct common room anomalies. The XLR input handles both mic and line level signals, so you can just hook up a mic and be heard, assuming you have something to say. There’s even an XLR Thru that allows you to easily “daisy chain” multiple TH-15As for increased coverage.

The TH-15A harnesses Mackie’s Active technology, including transducer time alignment, phase correction and precision crossovers, maximizing the potential of every component. The THUMP is truly greater than the sum of its parts.

Convenient top and side handles are integrated into the rugged, impact-resistant polypropylene enclosure, providing a PA solution that is as durable as it is portable. And at only 36 lbs, it’s a breeze to pole-mount on a tripod or atop a subwoofer.

Mackie TH-15A “THUMP” — High-performance audio without the high price tag.

Here’s a quick look at all the features packed into the TH-15A loudspeakers:

- 100W HF and 300W LF power amplifiers (peak)
- 15” low-frequency woofer
- 1” high-frequency compression driver
- Flat frequency response (–10 dB, 40 Hz to 20 kHz)
- 24 dB/octave crossover at 3 kHz
- Low-frequency over-excursion protection
- High-strength lightweight polypropylene cabinet
- Ported, bass reflex design for enhanced bass performance
- Convenient portable design, with integrated handles in both sides and top
- High-density adiabatic fiberfill absorbs internal reflections
- Rear panel power switch
- Pole-mount socket
- Balanced Mic/Line XLR input and thru connectors
- Adjustable input level control
- LF EQ provides ± 15 dB at 80 Hz and below
- MF EQ provides ± 15 dB with sweepable frequency from 100 Hz to 8 kHz
- HF EQ provides ± 15 dB at 12 kHz and above
- EQ bypass switch

Stereo Speaker Hookup

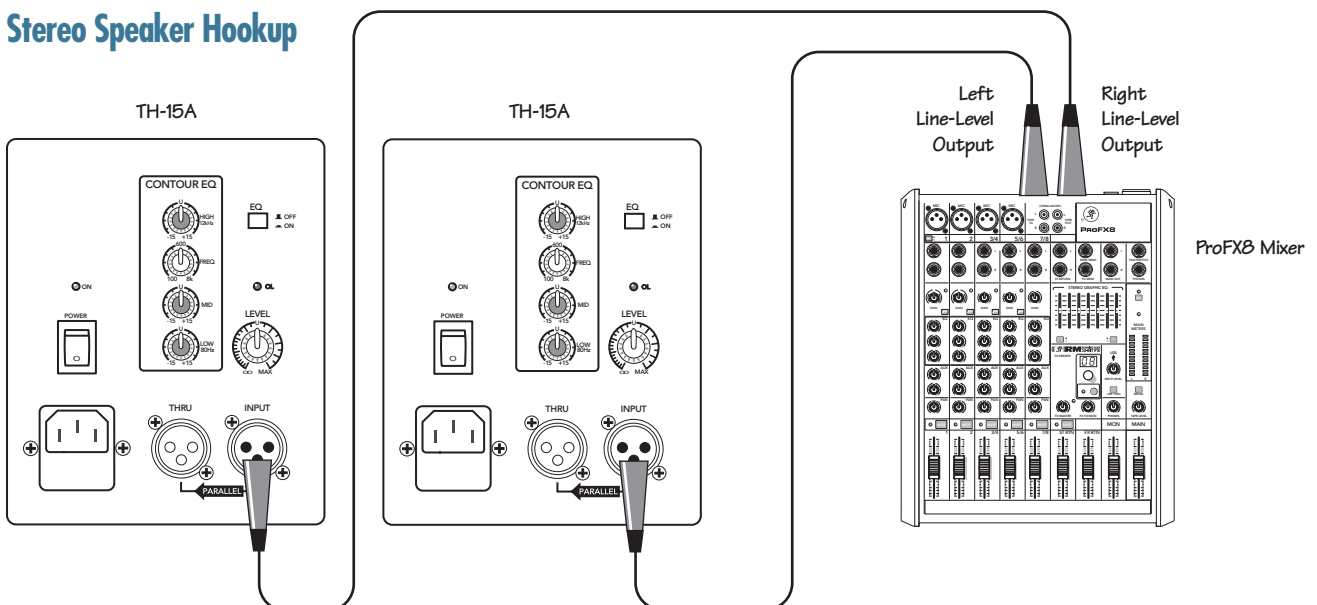

The left and right line-level outputs from a mixer feed the inputs of two Mackie TH-15A Powered Loudspeakers.

Daisy-Chaining Two Speakers Per Side

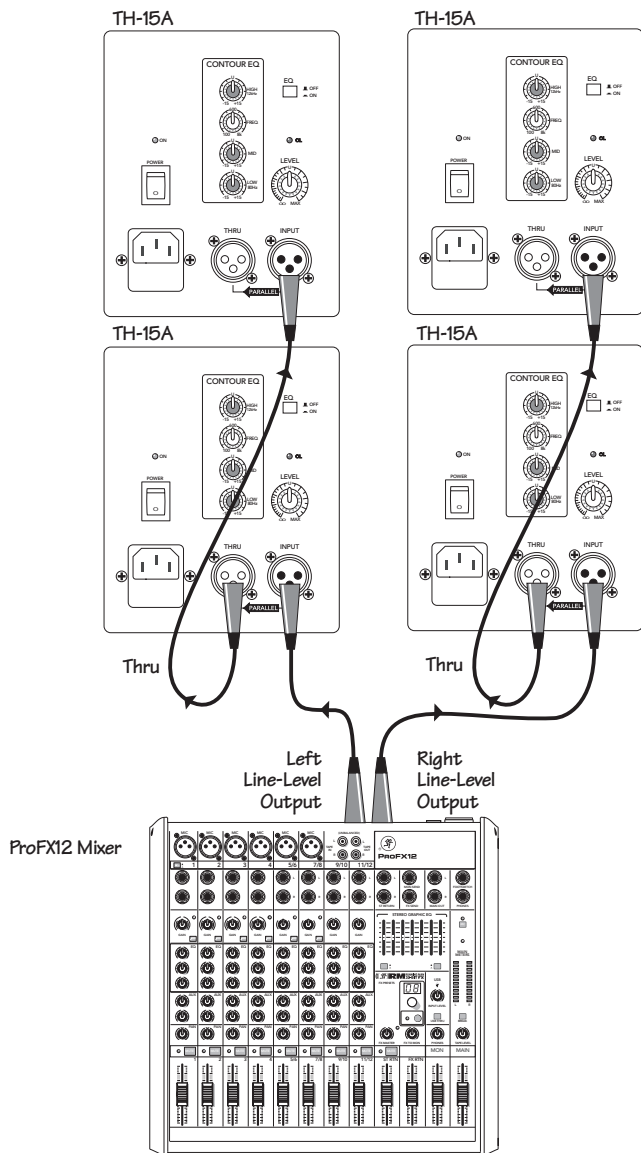

The left and right line-level outputs from a mixer feed the inputs of two Mackie TH-15A Powered Loudspeakers. Their respective THRU jacks feed the inputs of another pair of Mackie TH-15A Powered Loudspeakers.

Using a Microphone and the Thru Jack

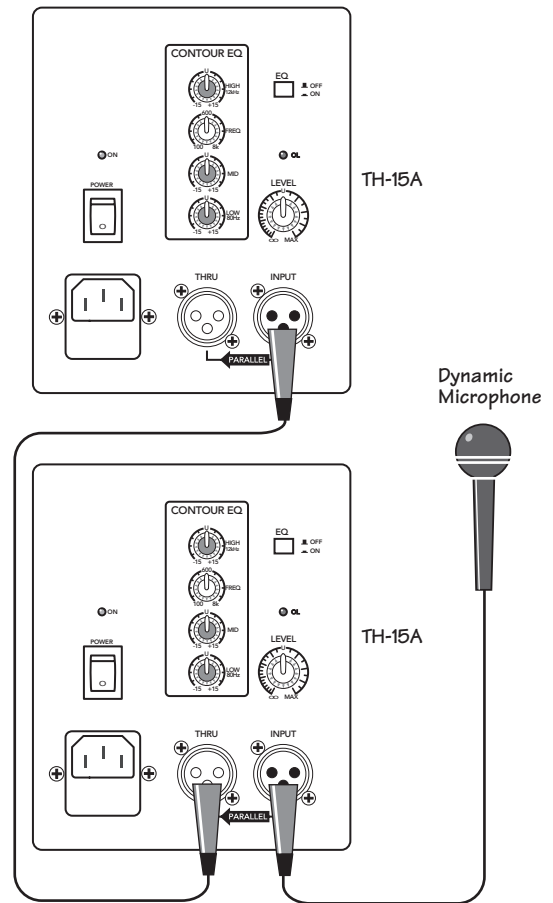

For microphone connections, you can daisy-chain up to two TH-15As using the THRU jack, as shown.

Take great care to point any microphones away from the loudspeakers. Otherwise, feedback may occur.

PA System with two powered subwoofers

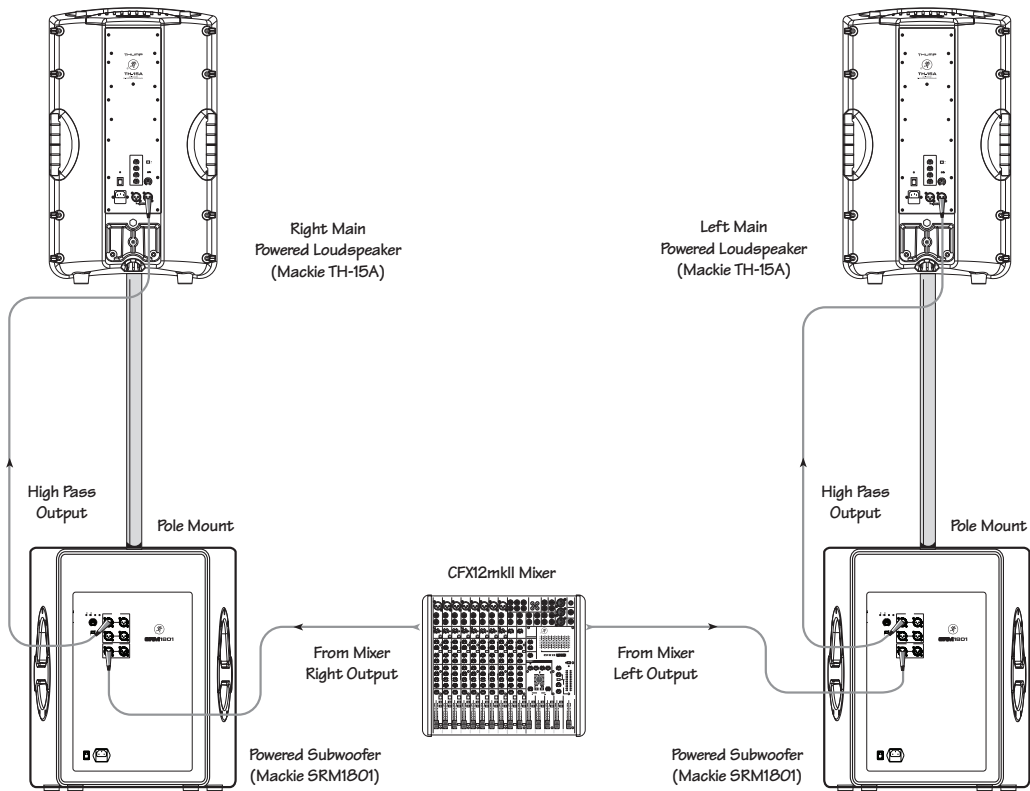

The left and right line-level outputs from a mixer feed the inputs of two powered subwoofers. The high pass line-level outputs of the subwoofers feed the inputs of the Mackie TH-15A loudspeakers.

PA System with one powered subwoofer

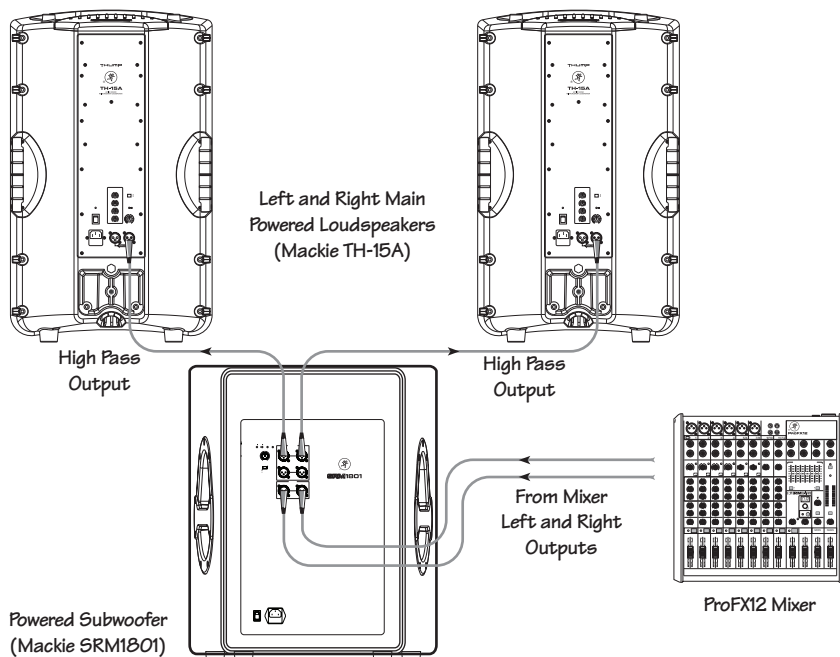

The left and right line-level outputs from a mixer feed the inputs of a powered subwoofer. The high pass line-level outputs of the subwoofer feed the inputs of the Mackie TH-15A loudspeakers.

Mackie TH-15A Features

REAR PANEL DESCRIPTION

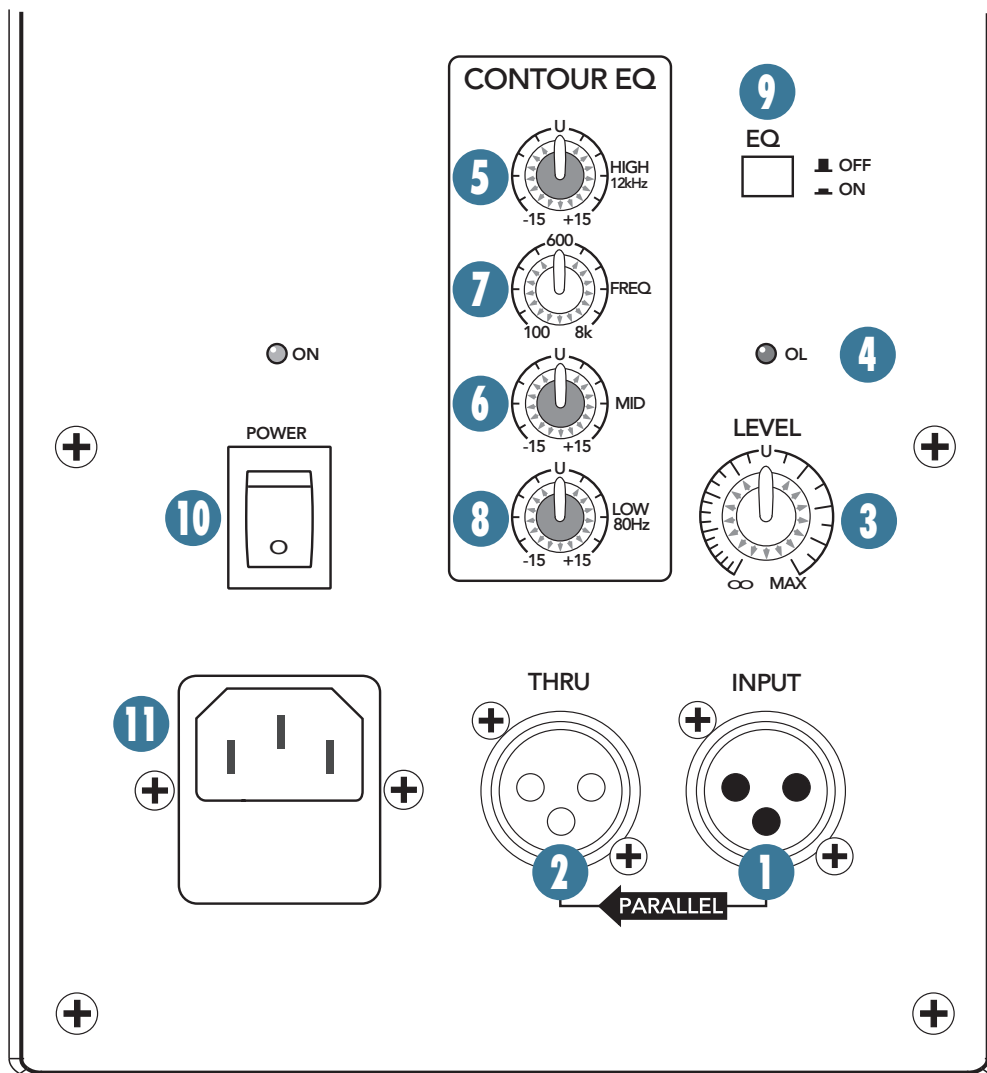

This is where you connect AC power and your signal to the loudspeaker and make adjustments to the frequency response of the speaker to match the loudspeaker's location and your room's environment.

1. INPUT

This is a female XLR-type connector that accepts a balanced mic or line-level signal from a mixing console or other signal source. For small gigs, simply connect a microphone directly and adjust the LEVEL accordingly.

2. THRU

This is a male XLR-type connector that produces exactly the same signal that is connected to the input jack. Use it to daisy-chain several TH-15A's together off the same signal source.

3. LEVEL

The LEVEL control adjusts the overall signal level at the input to the built-in power amplifiers. It ranges from Off (∞) to MAX (maximum gain), with unity gain at the center position (12 o'clock).

- The TH-15A is designed to operate with a +4 dBu signal when the LEVEL control is at the U (center) position.
- The TH-15A can accept up to a +20 dBu signal by turning down the LEVEL control accordingly. Turning the LEVEL past unity will provide enough gain to connect a microphone directly.
- NEVER connect the output of an amplifier directly to the input of the TH-15A. This could damage the active input circuitry of the loudspeaker.

4. OL Indicator

The OL (overload) indicator lights when the amplifiers in the TH-15A are near the clipping point. It is okay if the OL indicator blinks occasionally, because this means that the transient peaks are just reaching the maximum output of the amplifiers and you are getting the most from your TH-15As.

If the OL indicator is blinking frequently or lighting continuously, turn down the LEVEL control [3] on the TH15A or turn down the signal at its source (e.g., the mixing console) until the OL indicator blinks occasionally or not at all.

5. HIGH EQ

This control gives you up to 15 dB boost or cut above 12 kHz. The circuit is flat (no boost or cut) at the center position (U). Use it to add sizzle to cymbals, and an overall sense of transparency or edge to the keyboards, vocals, guitar, and bacon frying. Turn it down a little to reduce sibilance, or to remove high frequency hiss.

6. MID EQ

This is a midrange EQ control that provides 15 dB of boost or cut centered at any frequency between 100 Hz and 8 kHz. The MID EQ circuit is flat (no boost or cut) at the center position (U). This frequency range includes most vocals (male at the lower end of the range and female at the upper end of the range), and the fundamentals and harmonics for many instruments.

7. MID FREQ

This knob ranges from 100 Hz to 8 kHz and determines the center frequency for the MID EQ filter. This allows you to zero in on the precise narrow band of frequencies you want to have affected by the MID EQ.

8. LOW EQ

This control gives you up to 15 dB of boost or cut below 80 Hz and it is also flat at the center position (U). This frequency range represents the punch in bass drums, bass guitar, fat synth patches, and some really serious male singers.

9. EQ ON/OFF Switch

This switch allows you to bypass the EQ section. When the switch is out (OFF), the EQ section is bypassed and the EQ knobs have no effect on the signal. When the switch is pushed in (ON), the EQ controls can be used to tailor the frequency response of the TH-15A.

10. POWER Switch

Use this switch to turn the TH-15A loudspeaker on and off. The indicating LED above the POWER switch lights when the POWER switch is on and AC power is available at the linecord socket. A second power indicator is located on the front of the cabinet.

11. Line Cord Socket and Fuse

Connect the detachable line cord to this IEC socket securely, and plug the other end into your AC outlet. Make sure the AC power is matched to the AC power indicated on the rear panel (under the IEC socket).

The fuse is located behind the fuse cover, at the bottom of the IEC socket. See the “Troubleshooting” section on page 11 for information about replacing the fuse.

Protection Circuits

There are several protection mechanisms designed into the TH-15A to safeguard the loudspeakers and amplifiers from inadvertent damage.



CAUTION: The protection circuits are designed to protect the loudspeakers under reasonable and sensible conditions. Should you choose to ignore the warning signs (i.e., frequent OL LED indications, excessive distortion), you can still damage the speakers in the TH-15A by overdriving them past the point of amplifier clipping. Such damage is beyond the scope of the warranty.

Overexcursion Protection

A 12 dB/octave high-pass filter at 40 Hz just prior to the low-frequency amplifier prevents very low frequencies from being amplified. Excessive low-frequency energy below 40 Hz can damage the woofer by causing it to “bottom out,” also known as overexcursion, which is equivalent to a mechanical form of clipping.

Thermal Protection

All amplifiers produce heat. The TH-15A is designed to be efficient both electrically and thermally.

The amplifier module is mounted on a large heatsink, which is cooled by convection where cool air is drawn over the rear panel, carrying the heat away. In order for this convection cooling to work efficiently, it is important to provide adequate airspace behind the loudspeaker. When you position the TH-15A, we recommend leaving at least six inches of air space behind it.

- If for some reason the internal temperature gets too hot, a built-in thermal switch activates and turns off the amplifier. This protection operates independently for the low-frequency and high-frequency amplifiers. Therefore, it is possible for only the low frequency or high frequency amplifier to shut down while the other remains on.
- When the amplifier cools down to a safe temperature, the thermal switch resets and normal operation resumes.

- If the internal temperature again gets too hot, the shutdown process repeats. Should this happen, make sure that airflow to the rear of the cabinet is not restricted. If the ambient air temperature is very warm, try pointing a small fan toward the rear panel to increase the airflow through the fins.

Driver Protection

Each driver has its own compression circuit, which helps protect them from damaging transient peaks. The compressors are designed to be transparent and are not noticeable under normal operating conditions.

Input Signal Wiring

You should use high-quality, shielded cable to connect the signal source to the INPUT jack on the TH-15A.

- High quality microphone cables work well.
- Foil shielded cables are commonly used for audio wiring.
- The better the shield, the better the immunity from externally induced noise (like EMI and RFI). Route the cable away from AC power cords and outlets. These are common sources for hum in an audio signal. You can purchase quality cables from your Mackie dealer.

Placement

The TH-15A loudspeaker is designed to sit on the floor or stage. It can be pole-mounted via the built-in socket on the bottom of the cabinet. Be sure the pole is capable of supporting the weight of the TH-15A.



WARNING: The cabinet has no rigging points and is not suitable for rigging. **NEVER** attempt to suspend the TH-15A by its handles.

As with any powered components, protect them from moisture. If you are setting them up outdoors, make sure they are under cover if you expect rain.

Appendix A: Service Information

If you think your Mackie product has a problem, please check out the following troubleshooting tips and do your best to confirm the problem. Visit the Support section of our website (www.mackie.com) to get some ideas or contact our technical support heroes. You may find the answer to the problem without having to send your Mackie product away.

Troubleshooting

No Power

- Our favorite question: Is it plugged in?
- Make sure the line cord is securely seated in the line cord socket and plugged all the way into the AC outlet.
- Make sure the AC outlet is live (check with a tester or lamp).
- Is the POWER switch in the ON position?
- Are the power LEDs on the front and rear panel illuminated? If not, make sure the AC outlet is live. If so, refer to “No Sound” below.
- If the power LEDs are not illuminated, and you are certain that the AC outlet is live, it is possible the fuse has blown.

To remove and replace the fuse:

1. Disconnect the power cord from the IEC socket.
2. Remove the fuse drawer by prying it open with a small screwdriver. It will slide all the way out.

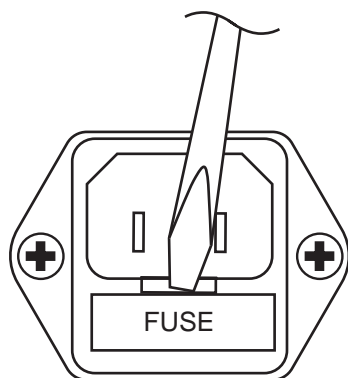

3. Remove the fuse and replace it with an equivalent-type fuse.
115 VAC unit: 6.3 amp slo-blo (T6.3AL/250 V)
230 VAC unit: 3.15 amp slo-blo (T3.15AL/250 V)

4. Replace the fuse drawer by pushing it all the way back into the IEC socket.

If two fuses blow in a row, then something is very wrong. Try a different outlet in a totally different location. If fuses continue to blow, see the “Repair” section on the next page to find out what to do.

No Sound

- Are the power LEDs on the front and rear panel illuminated?
- Is the LEVEL control turned up?
- Is the signal source turned up? Make sure the signal level from the mixing console (or whatever device immediately precedes the loudspeaker) is high enough to produce sound.
- If it's a stereo pair, try switching them around. For example, if a left speaker is presumed dead, switch the left and right cords at the speakers. If the problem switches sides, it's not the TH-15A. It could be a bad cable, or no signal from the mixer.

Bad Sound

- Is the input connector plugged completely into the IN jack?
- Is something connected to the THRU jack? Try unplugging it. If the sound improves, whatever was plugged into the THRU jack may have affected the signal.
- Is it loud and distorted? Reduce the signal level at the mixer.
- If possible, listen to the signal source with headphones plugged into the preamp stage. If it sounds bad there, it's not the loudspeaker.
- Too much bass or not enough bass? Move around the room and see if the bass response changes. It's possible your listening position coincides with a room mode where the low frequencies either become exaggerated or nulled. If so, try moving the loudspeakers to a different position, or moving your listening position.

Noise/Hum

- Check the signal cable between the mixer and the loudspeaker. Make sure all connections are secure. These problems usually produce crackling noises or hum.
- If you are using two or more TH-15A powered loudspeakers, try plugging them all into the same AC outlet panel or outlet strip. The purpose for this is to connect them all to the same earth ground point and reduce the possibility of creating a ground loop.
- If connecting an unbalanced output to the TH-15A balanced input, make sure the shield is connected to the unbalanced ground and to pin 1 of the XLR.

Repair

For warranty service, refer to the warranty information on page 15.

Non-warranty service for Mackie products is available at a factory-authorized service center. To locate your nearest service center, call our Tech Support department at 1-800-898-3211, Monday-Friday, during normal business hours, Pacific Time, to explain the problem. Tech Support will tell you where the nearest factory-authorized service center is located in your area.

Appendix B: Connections

XLR Connectors

XLR connectors are used to make balanced input and through connections to the TH-15A. They are wired as follows, according to standards specified by the AES (Audio Engineering Society).

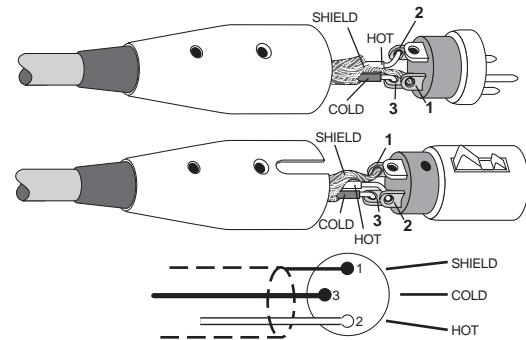

XLR Balanced Wiring

- Pin 1 = Shield
- Pin 2 = Hot (+)
- Pin 3 = Cold (-)

Need help with your new loudspeaker?

- Visit www.mackie.com and click Support to find: FAQs, manuals, addendums, and other documents.
- Email us at: techmail@mackie.com.
- Telephone 1-800-898-3211 to speak with one of our splendid technical support chaps (Monday through Friday, normal business hours, PST).

Appendix C: TH-15A Specifications

Acoustic Performance

| | |
|-----------------------------|------------------|
| Frequency Range (-10 dB): | 40 Hz – 20 kHz |
| Frequency Response (-3 dB): | 50 Hz – 18.5 kHz |
| Horizontal Coverage Angle: | 90° |
| Vertical Coverage Angle: | 60° |
| Maximum SPL Long-Term: | 118 dB SPL @ 1m |
| Maximum SPL Peak: | 121 dB SPL @ 1m |

Input/Output

| | |
|------------------|--|
| Input Type: | Female XLR Balanced / Unbalanced |
| Input Impedance: | 20 kΩ balanced bridging; 10 kΩ unbalanced |
| Loop-through: | Male XLR Balanced / Unbalanced (parallel with input) |
| Level Control: | Rotating knob 0 dB at center |
| Sensitivity: | +4 dBu for full output (Level Control @ Center) -36 dBu for full output (Level Control @ Max) |

Transducers

| | |
|-----------------|--|
| Low Frequency: | 15 in / 381 mm with steel frame, paper cone woofer |
| High Frequency: | Horn-loaded 1 in / 25 mm exit compression driver |

Power Amplifiers

| | |
|--------------------------------|--|
| Low Frequency Power Amplifier | |
| Rated Power: | 150 watts, 8 ohm load 300 watts peak |
| Signal-to-Noise Ratio: | > -94 dB, 20 Hz to 20 kHz, unweighted, referenced to 138 watts into 8 ohms |
| Design: | BTL Class D |
| High Frequency Power Amplifier | |
| Rated Power: | 50 watts, 4 ohm load 100 watts peak |
| Signal-to-Noise Ratio: | > -97 dB, 20 Hz to 20 kHz, unweighted, referenced to 50 watts into 4 ohms |
| Design: | Class AB |

Electronic Crossover

| | |
|----------------------|--------------|
| Crossover Type: | 24 dB/octave |
| Crossover Frequency: | 3 kHz |

Equalization

| | |
|--------------------|--|
| Low Frequency EQ: | ±15 dB @ 80 Hz, shelving |
| Mid Frequency EQ: | ±15 dB, bandpass, sweepable from 100 Hz to 8 kHz |
| High Frequency EQ: | ±15 dB @ 12 kHz, shelving |
| Direct/EQ Switch: | Bypasses EQ section |

Protection Features

| | |
|----------------------------|--|
| Over-excursion Protection: | Second-order sub-sonic filter |
| Thermal Protection: | Independent amplifier shutdown, auto reset |
| Driver Protection: | Independent HF and LF compressors |

AC Power Requirements

| | |
|---------------|--|
| US: | 100 – 120 VAC, 50 – 60 Hz 320 watts |
| EU, CN: | 200 – 240 VAC, 50 – 60 Hz 320 watts |
| AC Connector: | 3-pin IEC 250 VAC, 20 A male |

Construction Features

| | |
|------------------------|---|
| Basic Design: | Asymmetrical Trapezoidal |
| Material: | Polypropylene |
| Finish: | Textured |
| Handles: | One on each side, one on top |
| Grille: | Perforated metal with weather-resistant coating |
| Display LEDs | |
| Front: | Power ON |
| Rear: | Power ON, OL (overload) |
| Operating Temperature: | 0° – 40°C 32° – 104°F |

Physical Dimensions and Weight

| | |
|------------|------------------|
| Dimensions | |
| Height: | 27.6 in / 702 mm |
| Width: | 16.8 in / 427 mm |
| Depth: | 15.5 in / 394 mm |
| Weight: | 36 lb / 16.3 kg |

Mounting Methods:

Pole-mountable via the built-in socket on the bottom of the cabinet. Be sure the pole is capable of supporting the weight of the TH-15A.

TH-15A Dimensions

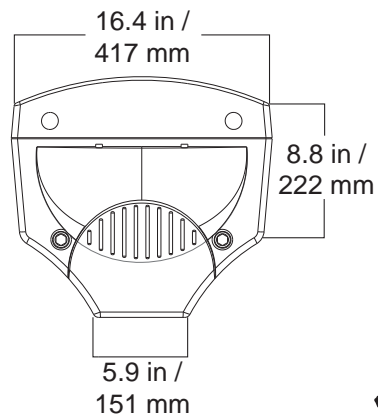
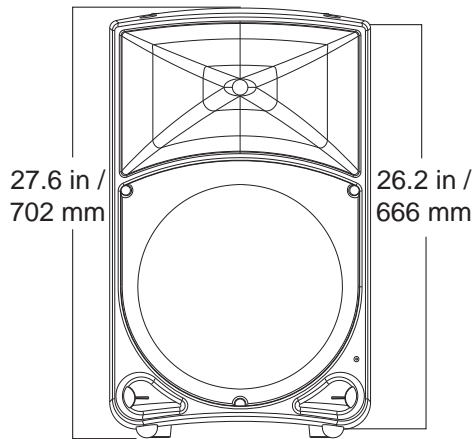

WEIGHT
36 lb
16.3 kg

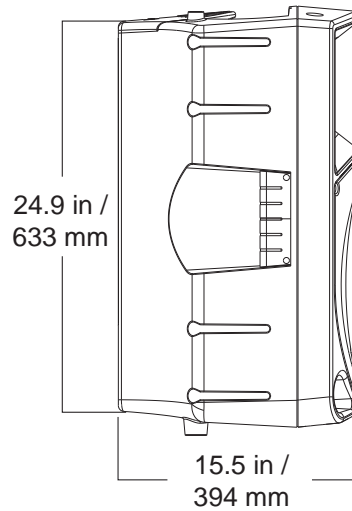
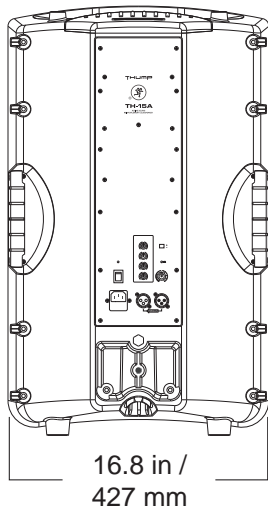

TH-15A Frequency Response

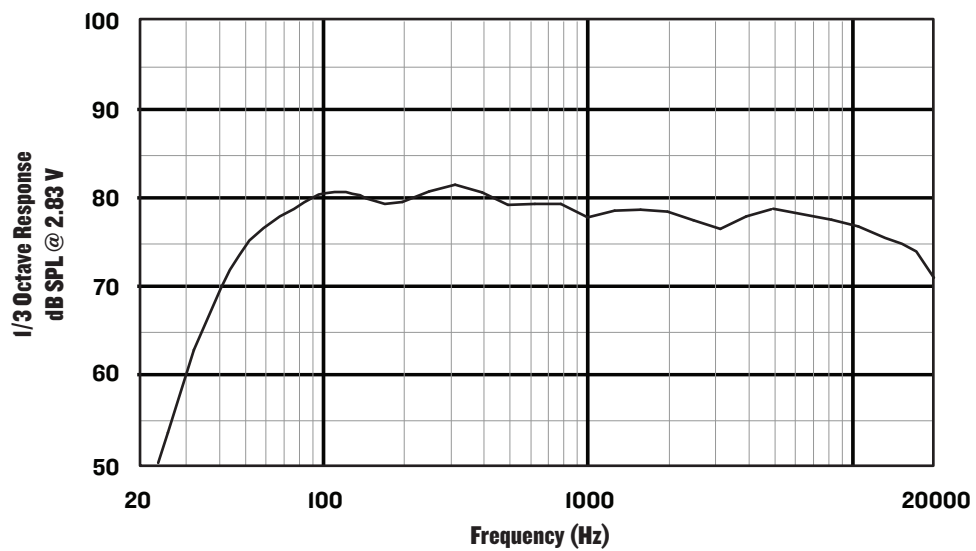

TH-15A Block Diagram

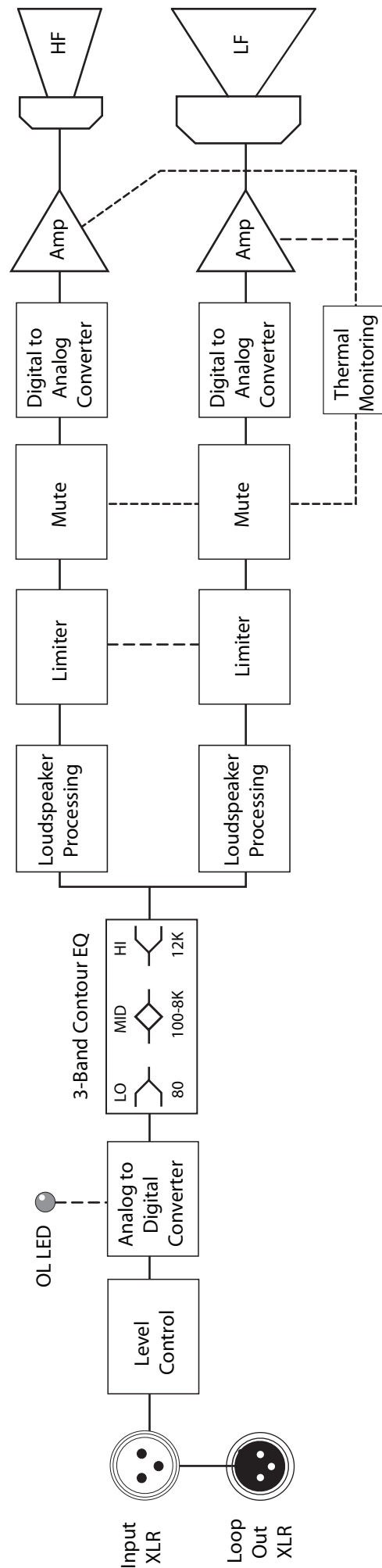

LOUD Technologies Inc. is always striving to improve our products by incorporating new and improved materials, components, and manufacturing methods. Therefore, we reserve the right to change these specifications at any time without notice.

“Mackie,” and the “Running Man” are registered trademarks of LOUD Technologies Inc. All other brand names mentioned are trademarks or registered trademarks of their respective holders, and are hereby acknowledged.

©2011 LOUD Technologies Inc. All Rights Reserved.

Mackie Limited Warranty

Please keep your sales receipt in a safe place.

This Limited Product Warranty (“Product Warranty”) is provided by LOUD Technologies Inc. (“LOUD”) and is applicable to products purchased in the United States or Canada through a LOUD-authorized reseller or dealer. The Product Warranty will not extend to anyone other than the original purchaser of the product (hereinafter, “Customer,” “you” or “your”).

For products purchased outside the U.S. or Canada, please visit www.mackie.com/warranty to find contact information for your local distributor, and information on any warranty coverage provided by the distributor in your local market.

LOUD warrants to Customer that the product will be free from defects in materials and workmanship under normal use during the Warranty Period. If the product fails to conform to the warranty then LOUD or its authorized service representative will at its option, either repair or replace any such nonconforming product, provided that Customer gives notice of the noncompliance within the Warranty Period to the Company at: www.mackie.com/support or by calling LOUD technical support at 1.800.898.3211 (toll-free in the U.S. and Canada) during normal business hours Pacific Time, excluding weekends or LOUD holidays. Please retain the original dated sales receipt as evidence of the date of purchase. You will need it to obtain any warranty service.

For full terms and conditions, as well as the specific duration of the Warranty for this product, please visit www.mackie.com/warranty.

The Product Warranty, together with your invoice or receipt, and the terms and conditions located at www.mackie.com/warranty constitutes the entire agreement, and supersedes any and all prior agreements between LOUD and Customer related to the subject matter hereof. No amendment, modification or waiver of any of the provisions of this Product Warranty will be valid unless set forth in a written instrument signed by the party to be bound thereby.



Correct Disposal of this product: This symbol indicates that this product should not be disposed of with your household waste, according to the WEEE Directive (2002/96/EC) and your national law. This product should be handed over to an authorized collection site for recycling waste electrical and electronic equipment (EEE). Improper handling of this type of waste could have a possible negative impact on the environment and human health due to potentially hazardous substances that are generally associated with EEE. At the same time, your cooperation in the correct disposal of this product will contribute to the effective usage of natural resources. For more information about where you can drop off your waste equipment for recycling, please contact your local city office, waste authority, or your household waste disposal service.

MACKIE®

16220 Wood-Red Road NE • Woodinville, WA 98072 • USA

United States and Canada: 800.898.3211

Europe, Asia, Central and South America: 425.487.4333

Middle East and Africa: 31.20.654.4000

Fax: 425.487.4337 • www.mackie.com

E-mail: sales@mackie.com