

# Service Manual

CDR510 /F1B/N1B/U1B

CD Recorder/CD Player

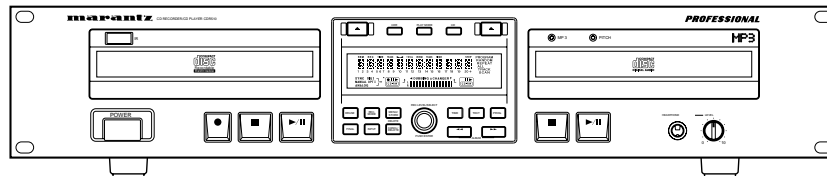

CDR510

## TABLE OF CONTENTS

SECTION	PAGE
1. TECHNICAL SPECIFICATIONS .....	1
2. SERVICE HINTS AND TOOLS .....	3
3. WARNING AND LASER SAFETY INSTRUCTIONS.....	4
4. ADJUSTMENT .....	5
5. TECHNICAL DESCRIPTION .....	8
6. SERVICE PROCEDURE.....	12
7. SERVICE MODE.....	14
8. WIRING DIAGRAM .....	15
9. BLOCK DIAGRAM .....	17
10. SCHEMATIC DIAGRAM.....	19
11. PARTS LOCATION.....	39
12. IC DATA .....	43
13. EXPLODED VIEW AND PARTS LIST .....	53
14. ELECTRICAL PARTS LIST .....	57

Please use this service manual with referring to the user guide ( D.F.U. ) without fail.  
修理の際は、必ず取扱説明書を準備し操作方法を確認の上作業を行ってください。

# marantz®

## CDR510

## MARANTZ DESIGN AND SERVICE

Using superior design and selected high grade components, **MARANTZ** company has created the ultimate in stereo sound. Only original **MARANTZ** parts can insure that your **MARANTZ** product will continue to perform to the specifications for which it is famous.

Parts for your **MARANTZ** equipment are generally available to our National Marantz Subsidiary or Agent.

### ORDERING PARTS :

Parts can be ordered either by mail or by Fax.. In both cases, the correct part number has to be specified.

The following information must be supplied to eliminate delays in processing your order :

1. Complete address
2. Complete part numbers and quantities required
3. Description of parts
4. Model number for which part is required
5. Way of shipment
6. Signature : any order form or Fax. must be signed, otherwise such part order will be considered as null and void.

#### USA

**MARANTZ AMERICA, INC**  
1100 MAPLEWOOD DRIVE  
ITASCA, IL. 60143  
USA  
PHONE : 630 - 741 - 0300  
FAX : 630 - 741 - 0301

#### EUROPE / TRADING

**MARANTZ EUROPE B.V.**  
P. O. BOX 8744, BUILDING SILVERPOINT  
BEEMDSTRAAT 11, 5653 MA EINDHOVEN  
THE NETHERLANDS  
PHONE : +31 - 40 - 2507844  
FAX : +31 - 40 - 2507860

#### CANADA

**LENBROOK INDUSTRIES LIMITED**  
633 GRANITE COURT,  
PICKERING, ONTARIO L1W 3K1  
CANADA  
PHONE : 905 - 831 - 6333  
FAX : 905 - 831 - 6936

#### PROFESSIONAL AMERICAS

**SUPERSCOPE TECHNOLOGIES, INC.**  
MARANTZ PROFESSIONAL PRODUCTS  
2640 WHITE OAK CIRCLE, SUITE A  
AURORA, ILLINOIS 60504 USA  
PHONE : 630 - 820 - 4800  
FAX : 630 - 820 - 8103

#### PROFESSIONAL AUSTRALIA

**TECHNICAL AUDIO GROUP PTY, LTD**  
43-53 Bridge Rd.,  
STANMORE NSW 2048  
AUSTRALIA  
PHONE : +61 - (0)2 - 9519 - 0900  
FAX : +61 - (0)2 - 9519 - 0600

#### PROFESSIONAL HONG KONG

**Jolly ProAudio Broadcast Engineering Ltd.**  
UNIT 2, 10F, WAH HUNG CENTRE,  
41 HUNG TO ROAD, KWUN TONG, KLN.,  
HONG KONG  
PHONE : 852 - 21913660  
FAX : 852 - 21913990

#### AUSTRALIA

**QualiFi Pty Ltd,**  
24 LIONEL ROAD,  
MT. WAVERLEY VIC 3149  
AUSTRALIA  
PHONE : +61 - (0)3 - 9543 - 1522  
FAX : +61 - (0)3 - 9543 - 3677

#### THAILAND

**MRZ STANDARD CO., LTD**  
746 - 754 MAHACHAI ROAD.,  
WANGBURAPAPIROM, PHRANAKORN,  
BANGKOK, 10200 THAILAND  
PHONE : +66 - 2 - 222 9181  
FAX : +66 - 2 - 224 6795

#### SINGAPORE

**WO KEE HONG DISTRIBUTION PTE LTD**  
130 JOO SENG ROAD  
#03-02 OLIVINE BUILDING  
SINGAPORE 368357  
PHONE : +65 6858 5535 / +65 6381 8621  
FAX : +65 6858 6078

#### NEW ZEALAND

**WILDASH AUDIO SYSTEMS NZ**  
14 MALVERN ROAD MT ALBERT  
AUCKLAND NEW ZEALAND  
PHONE : +64 - 9 - 8451958  
FAX : +64 - 9 - 8463554

#### TAIWAN

**PAI- YUING CO., LTD.**  
6 TH FL NO, 148 SUNG KIANG ROAD,  
TAIPEI, 10429, TAIWAN R.O.C.  
PHONE : +886 - 2 - 25221304  
FAX : +886 - 2 - 25630415

#### MALAYSIA

**WO KEE HONG ELECTRONICS SDN. BHD.**  
2ND FLOOR BANGUNAN INFINITE CENTRE  
LOT 1, JALAN 13/6, 46200 PETALING JAYA  
SELANGOR DARUL EHSAN, MALAYSIA  
PHONE : +60 - 3 - 7954 8088  
FAX : +60 - 3 - 7954 7088

#### JAPAN Technical

**MARANTZ JAPAN, INC.**  
35- 1, 7- CHOME, SAGAMIONO  
SAGAMIHARA - SHI, KANAGAWA  
JAPAN 228-8505  
PHONE : +81 42 748 1013  
FAX : +81 42 741 9190

#### 日本マランツ株式会社

本社 〒228-8505  
神奈川県相模原市相模大野7-35-1

#### KOREA

**MK ENTERPRISES LTD.**  
ROOM 604/605, ELECTRO-OFFICETEL, 16-58,  
3GA, HANGANG-RO, YONGSAN-KU, SEOUL  
KOREA  
PHONE : +822 - 3232 - 155  
FAX : +822 - 3232 - 154

### SHOCK, FIRE HAZARD SERVICE TEST :

**CAUTION :** After servicing this appliance and prior to returning to customer, measure the resistance between either primary AC cord connector pins ( with unit NOT connected to AC mains and its Power switch ON ), and the face or Front Panel of product and controls and chassis bottom.

Any resistance measurement less than 1 Megohms should cause unit to be repaired or corrected before AC power is applied, and verified before it is return to the user/customer.

Ref. UL Standard No. 1492.

In case of difficulties, do not hesitate to contact the Technical Department at above mentioned address.

# 1. TECHNICAL SPECIFICATIONS

## GENERAL

System .....	Compact disc digital audio
Number of channels .....	2 (stereo)
Applicable discs .....	CD, CD-R, CD-RW, MP3
Power Requirement [F] .....	AC 100 V 50/60 Hz
[N] .....	AC 100 - 240 V 50/60 Hz
[U] .....	AC 120 V 60 Hz
Power Consumption .....	20 W
Operating Temperature .....	
Dimension (MAX)	
Width .....	483 mm (19 inches)
Height .....	100 mm (3-15/16 inches)
Depth .....	340 mm (13-7/16 inches)
Weight .....	5.4 kg (11.9 lbs)

## AUDIO

ADC .....	3rd-order Sigma-Delta ADC 128 x over sampling
DAC .....	Filter Stream DAC 128 x over sampling
Frequency Response .....	20 Hz - 20 kHz
CDR OUT	
Playback S/N .....	96 dB
Playback Dynamic Range .....	85 dB
Payback Total Harmonic Distortion .....	82 dB
CD OUT	
Play back S/N .....	103 dB
Play back Dynamic Range .....	96 dB
Play back Total Harmonic Distortion .....	91 dB
Analog Output Voltage .....	2.0 Vrms
Analog Recording S/N .....	85 dB
Analog Recording Dynamic Range .....	82 dB
Analog Recording Total Harmonic Distortion .....	80 dB
Digital Coaxial Output .....	0.5 V (p-p) / 75 Ω
Digital Optical Output .....	- 20 dBm
Headphone .....	0 - 5 Vrms / 8 - 2000 Ω
Recording values for line input	
Digital Coaxial Input (automatic sample rate conversion) .....	32 / 44.1 / 48 kHz (11 kHz - 56 kHz)
Digital Optical Input (automatic sample rate conversion) .....	32 / 44.1 / 48 kHz (11 kHz - 56 kHz)
Analog Input Sensitivity (Unbalanced) .....	500 mVrms / 50 kΩ
(Balanced) .....	0 dBu to + 22 dBu / 50 kΩ
	(default setting : +16dBu/50 k )

## ACCESSORIES

Remote Control Unit RC2100DR .....	1
AA-size batteries .....	2
AC power cord .....	1
Audio cable (white and red) .....	2
RC-5 cable (orange) .....	1

**Playback & Recording and Disc**

The CDR510 is the professional version of a CD recorder, this means that the SCMS (Serial Copy Management System) is included. The CDR510 can only record on the Audio and PC CDRs.

The CDR510 is suitable for recording and playback of CD-RW discs (CD-ReWritable disc).

Disc  Player/Recorder	CD	CDR				CD-RW				SCMS
		Consumer Disc		Professional Disc		Consumer Disc		Professional Disc		
		Finalized	non Finalized	Finalized	non Finalized	Finalized	non Finalized	Finalized	non Finalized	
<b>Audio CD Player</b> Current products Ex:CD-17	<b>P</b>	<b>P</b>	no	<b>P</b>	no	no	no	no	no	-
<b>Audio CD Player</b> CD-RW playback Ex:CD-17MK II	<b>P</b>	<b>P</b>	no	<b>P</b>	no	<b>P</b>	no	<b>P</b>	no	-
<b>CD-RW Recorder</b> For Professional Ex:CDR510/500/631	<b>P</b>	<b>P</b>	<b>P/R</b>	<b>P</b>	<b>P/R</b>	<b>P/R</b>	<b>P/R</b>	<b>P/R</b>	<b>P/R</b>	no
<b>CD-RW Recorder</b> For Consumer Ex:DR6050	<b>P</b>	<b>P</b>	<b>P/R</b>	<b>P</b>	<b>P</b>	<b>P/R</b>	<b>P/R</b>	<b>P</b>	<b>P</b>	<b>YES</b>

Consumer : For Digital Audio

Professional : For General use (Including PC)

P : Playback

R : Recording

## 2. SERVICE HINTS AND TOOLS

### SERVICE HINTS

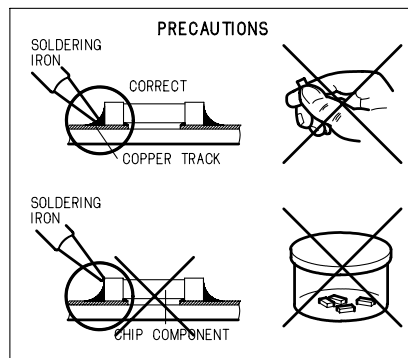
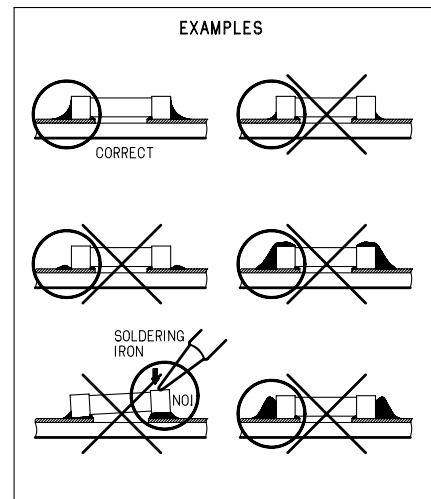
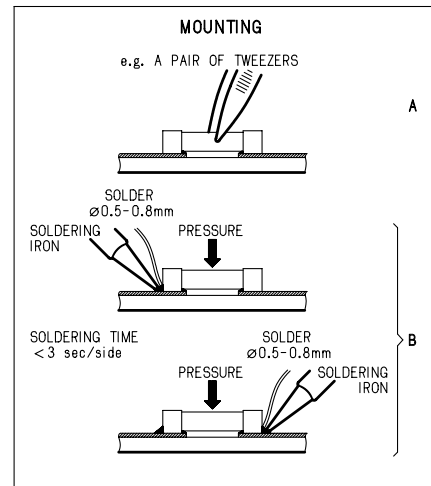
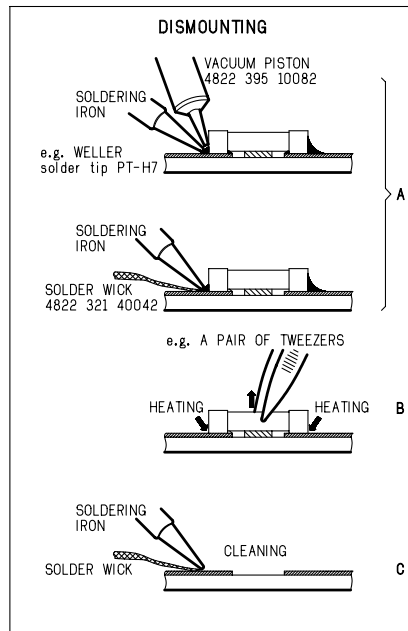
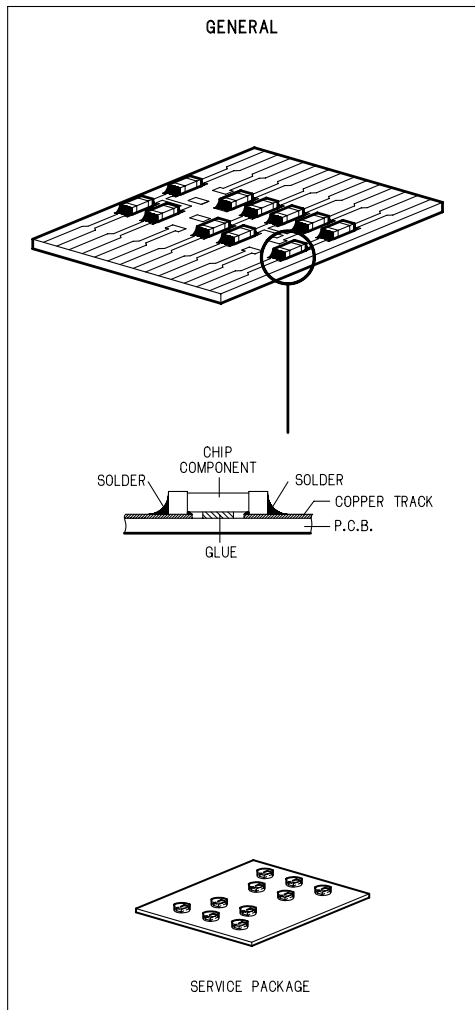

### SERVICE TOOLS

Audio signals disc

4822 397 30184

Disc without errors (SBC444)+Disc with DO errors, black spots and fingerprints (SBC444A)

4822 397 30245

Disc (65 min 1kHz) without no pause

4822 397 30155

Max. diameter disc (58.0 mm)

4822 397 60141

13th order filter

4822 395 30204

### 3. WARNING AND LASER SAFETY INSTRUCTIONS

#### **(GB)** WARNING

All ICs and many other semi-conductors are susceptible to electrostatic discharges (ESD). Careless handling during repair can reduce life drastically.  
When repairing, make sure that you are connected with the same potential as the mass of the set via a wrist wrap with resistance.  
Keep components and tools also at this potential.



#### **(NL)** WAARSCHUWING

Alle IC's en vele andere halfgeleiders zijn gevoelig voor elektrostatische ontladingen (ESD).  
Onzorgvuldig behandelen tijdens reparatie kan de levensduur drastisch doen verminderen.  
Zorg ervoor dat u tijdens reparatie via een polsband met weerstand verbonden bent met hetzelfde potentiaal als de massa van het apparaat.  
Houd componenten en hulpmiddelen ook op ditzelfde potentiaal.

#### **(F)** ATTENTION

Tous les IC et beaucoup d'autres semi-conducteurs sont sensibles aux décharges statiques (ESD).  
Leur longévité pourrait être considérablement écourtée par le fait qu'aucune précaution n'est prise à leur manipulation.  
Lors de réparations, s'assurer de bien être relié au même potentiel que la masse de l'appareil et enfiler le bracelet serti d'une résistance de sécurité.  
Veiller à ce que les composants ainsi que les outils que l'on utilise soient également à ce potentiel.

#### **(D)** WARNUNG

Alle IC und viele andere Halbleiter sind empfindlich gegen elektrostatische Entladungen (ESD).  
Unvorsichtige Behandlung bei der Reparatur kann die Lebensdauer drastisch vermindern.  
Sorgen sie dafür, das Sie im Reparaturfall über ein Pulsarmband mit Widerstand mit dem Massepotential des Gerätes verbunden sind.  
Halten Sie Bauteile und Hilfsmittel ebenfalls auf diesem Potential.

#### **(I)** AVVERTIMENTO

Tutti IC e parecchi semi-conduttori sono sensibili alle scariche statiche (ESD).  
La loro longevità potrebbe essere fortemente ridatta in caso di non osservazione della piu grande cauzione alla loro manipolazione.  
Durante le riparazioni occorre quindi essere collegato allo stesso potenziale che quello della massa dell'apparecchio tramite un braccialetto a resistenza.  
Assicurarsi che i componenti e anche gli utensili con quali si lavora siano anche a questo potenziale.

#### **(GB)**

Safety regulations require that the set be restored to its original condition and that parts which are identical with those specified be used.

#### **(NL)**

Veiligheidsbepalingen vereisen, dat het apparaat in zijn oorspronkelijke toestand wordt terug gebracht en dat onderdelen, identiek aan de gespecificeerde worden toegepast.

#### **(D)**

Bei jeder Reparatur sind die geltenden Sicherheitsvorschriften zu beachten.  
Der Originalzustand des Gerats darf nicht verändert werden.  
Für Reparaturen sind Original-Ersatzteile zu verwenden.

#### **(I)**

Le norme di sicurezza esigono che l'apparecchio venga rimesso nelle condizioni originali e che siano utilizzati pezzi di ricambio idetici a quelli specificati.

#### **(F)**

Les normes de sécurité exigent que l'appareil soit remis à l'état d'origine et que soient utilisées les pièces de rechange identiques à celles spécifiées.

"Pour votre sécurité, ces documents doivent être utilisés par des spécialistes agréés, seuls habilités à réparer votre appareil en panne."

### LASER SAFETY

This unit employs a laser. Only a qualified service person should remove the cover or attempt to service this device, due to possible eye injury.



**USE OF CONTROLS OR ADJUSTMENTS OR PERFORMANCE OF PROCEDURE OTHER THAN THOSE SPECIFIED HEREIN MAY RESULT IN HAZARDOUS RADIATION EXPOSURE.**

**AVOID DIRECT EXPOSURE TO BEAM**

**WARNING**

**The use of optical instruments with this product will increase eye hazard.  
Repair handling should take place as much as possible with a disc loaded inside the player**

**WARNING LOCATION: INSIDE ON LASER COVERSIELD**

**CAUTION** VISIBLE AND INVISIBLE LASER RADIATION WHEN OPEN AVOID EXPOSURE TO BEAM  
**ADVARSEL** SYNLIG OG USYNLIG LASERSTRÅLING VED ÅBNING UNDGÅ UDSÆTTELSE FOR STRÅLING  
**ADVARSEL** SYNLIG OG USYNLIG LASERSTRÅLING NÅR DEKSEL Å PNES UNNGÅ EKSPONERING FOR STRÅLEN  
**VARNING** SYNLIG OCH OSYNLIG LASERSTRÅLNING NÅR DENNA DEL ÅR ÖPPNAD BETRAKTA EJ STRÅLEN  
**VARO!** AVATT AESSA OLET ALTTIINA NÄKYVÄLLE JA NÄKYMÄTTÖMÄLLE LASER SÄTEILYLLE. ÄLÄ KATSO SÄTEESEEN  
**VORSICHT** SICHTBARE UND UNSICHTBARE LASERSTRAHLUNG WENN ABDECKUNG GEÖFFNET NICHT DEM STRAHL AUSSETSEN  
**DANGER** VISIBLE AND INVISIBLE LASER RADIATION WHEN OPEN AVOID DIRECT EXPOSURE TO BEAM  
**ATTENTION** RAYONNEMENT LASER VISIBLE ET INVISIBLE EN CAS D'OUVERTURE EXPOSITION DANGEREUSE AU FAISCEAU

## 4. ADJUSTMENTS

### 1) Balance Input Attenuate Level L, R Adjustment

- **Necessary Equipment**

Audio Signal generator (Correspond to Balance Out )  
 Audio Analyzer or Noise Meter  
 CD-RW for Audio recording

- **Adjustment procedure**

Attention :

When adjustment is insufficient, Input Sensitivity and Channel unbalance of BALANCE INPUT become Spec out.

1. Set INPUT SELECT switch to "BALANCED IN"
2. Connect output of Audio Signal Generator to ANALOG BALANCED IN. Connect Audio analyzer or Noise meter to ANALOG OUT.
3. Press POWER button to turn on the unit, insert a un-finalized CD-RW disc to CD-Recorder.
4. The display show the type of disc you inserted. Press INPUT button and select "ANALOG". (Press INPUT button repeatedly until the selected "ANALOG" appears the display)
5. Press REC MODE Button and select "REC Ext MAN".
6. The display show , and the unit become REC/PAUSE mode.
7. Turn REC LEVEL(JOG) knob , and adjust recording level to "0dB"
8. Adjust output level of Audio Signal Generator to "1 kHz / 4.887 Vrms (+ 16.0 dBu)", and a signal is outputted.
9. Adjust TRIM (variable resistance) of the L channel with the driver so that the reading numerical value of analyzer or Noise meter to become "1.8 Vrms ± 0.1 Vrms".
10. After that, adjust TRIM of the R channel with the driver to become "± 0.07 Vrms "toward the L channel.

- **Connection**

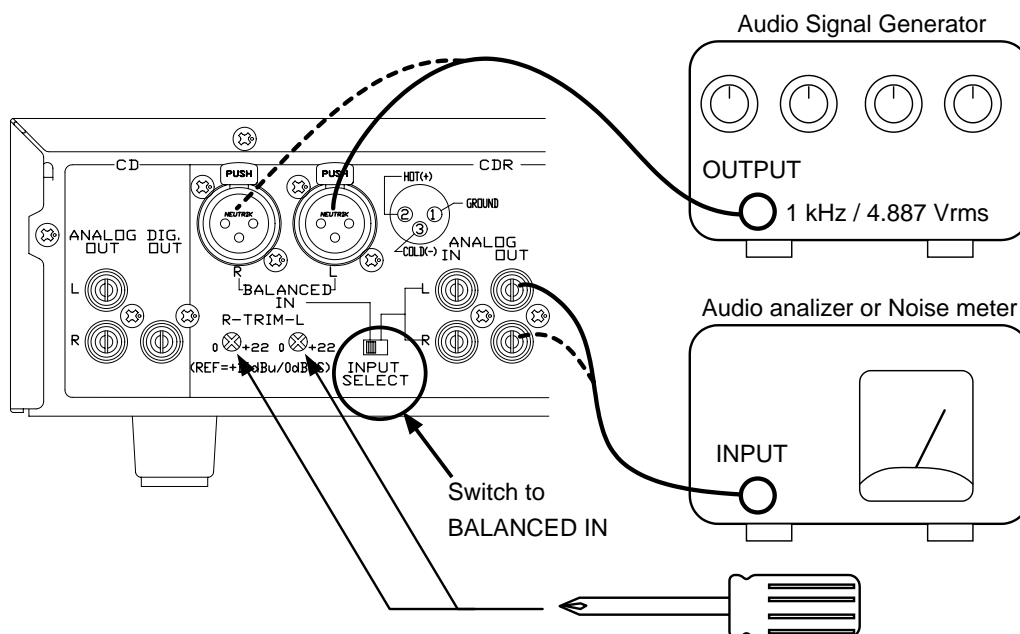

## 4. 調整

### 1) Balance Input Attenuate Level L, R の調整

- **調整用測定器類**

Audio Signal generator (Balance Out 対応)  
 Audio Analyzer または Noise Meter  
 音楽用 CD-RW (CD-RW for AUDIO)

- **調整手順**

注意：

調整不十分時は、BALANCE INPUT の Input Sensitivity 及び BALANCE INPUT の Channel unbalance が規格外となります。

1. 后面板の INPUT SELECT スイッチを BALANCED IN 側にします。
2. Audio Signal Generator の出力を ANALOG BALANCED IN に、Audio analyzer または Noise meter を ANALOG OUT に接続します。
3. 電源を入れ、ファイナライズしていない CD-RW を本体に挿入します。
4. DISC の読み込みが終了しましたら、INPUT ボタンを押して "ANALOG" を選択します。
5. REC MODE ボタンを押して "REC Ext MAN" を選択します。
6. 表示部に  と表示され、REC PAUSE 状態となります。
7. REC LEVEL (JOG) を回し録音レベルを "0 dB" に合わせます。
8. Audio Signal generator の出力を **1 kHz / 4.887 Vrms (+ 16.0 dBu)** に合わせ信号を出力します。
9. Audio analyzer または Noise meter の読み取り値が **1.8 Vrms ± 0.1 Vrms** になるように L チャンネルの TRIM( 可変抵抗 ) をドライバーで調整します。
10. その後、L チャンネルに対して **± 0.07 Vrms** になるように R チャンネルの TRIM ( 可変抵抗 ) をドライバーで調整します。

- **接続**

## 2) Disk Tray Open/Close Speed Adjustment

Open/Close speed of the tray can be changed.

When vibration occurs upon tray open/close and some unusual behavior happens, change the tray speed to stop vibration.

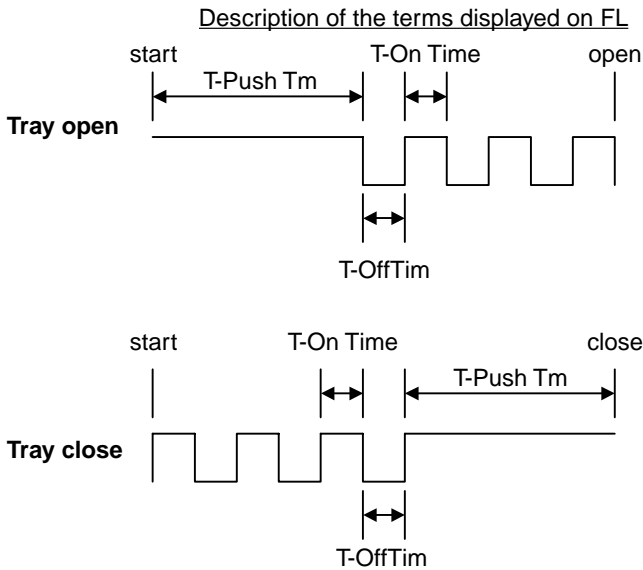

### T-PushTm

DC driving time on Tray open operation. Tray is DC driven at start opening. Then Tray is driven by pulse. Time can be set between 0-2550ms.

### T-On Time

Duration time of High in pulse drive. Time can be set between 0-255ms.

### T-OffTim

Duration time of Low in pulse drive. Time can be set between 0-255ms.

### T-PullCt

The number of pulses on Tray close operation.

### <Vibration on Disc Tray Open / Close>

**Step 1.** With pressing CDR **STOP** and CDR **PLAY/PAUSE** buttons, press **POWER** button.

**Step 2.** Press **REC LEVEL/SELECT(PUSH ENTER)** button.

"T-OnTime 015" (means Tray On Time 015ms default) is displayed.

Turn **REC LEVEL/SELECT** to change tray open/close speed from 000 to 255ms. Turn the number smaller to make the open/close speed slower. Turn the number bigger to make the speed faster. Set bigger number to stop the tray vibration. But the open/close speed becomes faster.

Press **REC LEVEL/SELECT** button again. The display changes as shown below so you can change other parameters for the open/close speed.

Display (Default Setting)	Description	Bigger Number	Smaller Number
<b>T- OffTim</b> 003	When open/close speed is too fast. Note) 001, 002, 003 cannot be set.	open/close speed becomes faster	open/close speed becomes slower
<b>T- PushTm</b> 070	When vibration cannot be stopped by adjusting <b>T-OnTime</b> .	open/close speed becomes slower	open/close speed becomes faster
<b>T- PullCt</b> 040	When disc clamp miss happens. Set smaller number to make it better.		

**Step 3.** Press **REC LEVEL/SELECT** button to complete adjustment.

**Step 4.** Press CD **STOP** button to store the settings in memory.

To reset all the settings to default status, press number 0 button in Service Mode 0 (Display : VER\_ \*-\*\* P00 ). When miss-operated, press number 0 button to retry.



## 2) Disc Tray の open/close speed 調整方法

この調整は、Disc Tray の open/close speed を可変できます。  
特に、Tray open/close にて Tray が横揺れし、不自然な動作が発生した時に open/close の speed 調整にて、Tray の横揺れが無くなります。

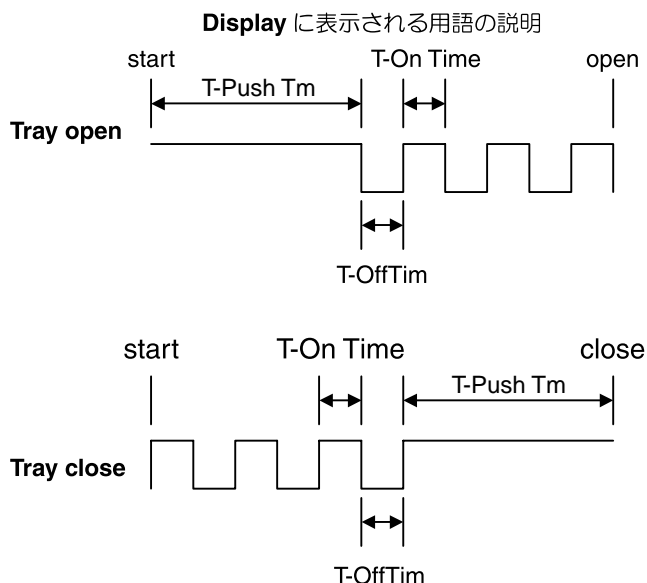

### T-PushTm

Tray open 動作時の DC 駆動時間です。open の start は DC 駆動です。その後パルス駆動になります。

0 ~ 2550ms 迄可変できます。

### T-On Time

パルス駆動の High の時間です。

0 ~ 255ms 迄可変できます。

### T-OffTim

パルス駆動の Low の時間です。

0 ~ 255ms 迄可変できます。

### T-PullCt

Tray close 動作時のパルスの数です。

### < Tray open/close 時の横揺れ >

手順 1. CDR STOP と CDR PLAY/PAUSE ボタンを押しながら POWER ボタンを押します。

手順 2. REC LEVEL/SELECT(PUSH ENTER) ボタンを押します。

Display に “ T- OnTime 015 ” (初期設定 Tray on time 015ms の意味) と表示。

REC LEVEL/SELECT ボタンを押し 000 から 255ms の範囲で Tray の open/close Speed が可変できます。数字が小さくなると open/close Speed は遅くなります。数字が大きくなると早くなります。

Tray の open/close の横揺れは数字を大きくする事により、横揺れは、無くなります。但し、open/close speed は速くなります。

更に REC LEVEL/SELECT ボタンを押す度に、下記の表示に変わり open/close speed を可変できます。

表示内容 (初期設定)	項目	数字を小さくする	数字を大きくする
T- OffTim 003	open/close speed が速すぎる時 注) 000・001・002 は使用出来ません。	open/close speed が速くなる	open/close speed が遅くなる
T- PushTm 070	open 時の横揺れが T- OnTime で修正できない時 DC 駆動時間を増す	open/close speed が遅くなる	open/close speed が速くなる
T- PullCt 040	クランプミスの時、数字を小さくするとクランプミスが改善されます。		

手順 3. REC LEVEL/SELECT ボタンを押すことで設定が決定します。

手順 4. CD STOP ボタンを押します。(メモリーされます)

初期設定に戻すときは、サービスモード 0(表示は VER\_ \* - \* \* P00)の時、数字ボタン「0」のボタンを押します。(操作を間違えた時も「0」のボタンを押し操作をやり直します)

## 5. TECHNICAL DESCRIPTION

### How to use the RS-232C connector

This input/output connector (D-Sub 9-pin female) is used for RS-232C external control.

A straight cable available on the market can be connected to this connector to exercise external control and send status information.

- Connector pin assignment**

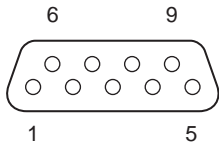

1	NC
2	TX
3	RX
4	NC
5	GND
6	NC
7	RTS
8	CTS
9	NC

- RS232C Connection**

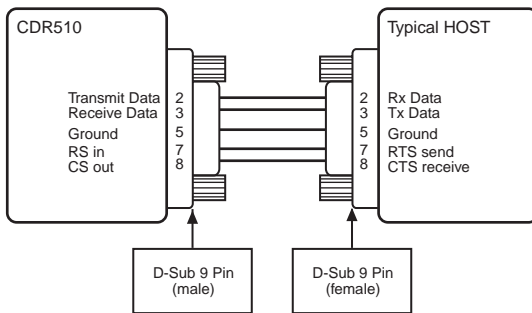

The wiring requirements for a 9 pin to 9 pin serial connection, are a male to female straight cable.

- RS-232C physical specifications**

Cable	Straight cable
Baud rate	9600 bps
Data bits	8 bits
Parity bit	None
Stop bit	1 bit
Flow control	CS/RS Hardware Flow

#### CS/RS Hardware Flow Control

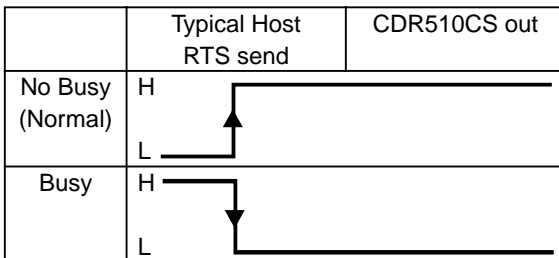

#### Timing chart

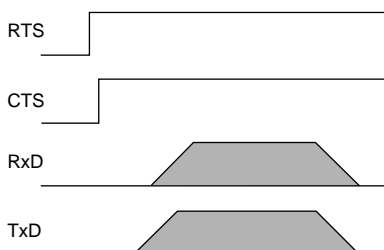

- Command reception**

The command packets have a data length of 7 - 10 bytes. ASCII codes from 0x00 to 0x7f are used to receive serial data. At the transmission end, therefore, take steps to convert the ASCII codes into HEX data to set the data in the data packets. CR (0x0d) is added as the data packet delimiter.

Example: "0" (code @12000)

[@]	[1]	[2]	[0]	[0]	[0]	[CR]
0x40	0x31	0x32	0x30	0x30	0x30	0x0d

When transmitting commands consecutively, put more than 100ms blank between commands.

#### Received command data

Request Command	CD Command	CDR Command
0	"@12000"+CR	"@12600"+CR
1	"@12001"CR	"@12601"+CR
2	"@12002"+CR	"@12602"+CR
3	"@12003"+CR	"@12603"+CR
4	"@12004"+CR	"@12604"+CR
5	"@12005"+CR	"@12605"+CR
6	"@12006"+CR	"@12606"+CR
7	"@12007"+CR	"@12607"+CR
8	"@12008"+CR	"@12608"+CR
9	"@12009"+CR	"@12609"+CR
Display	"@12015"+CR	"@12615"+CR
Scroll	"@12011"+CR	"@12611"+CR
Repeat	"@12029"+CR	"@12629"+CR
Next	"@12032"+CR	"@12632"+CR
Previous	"@12033"+CR	"@12633"+CR
Pitch Reset	"@12037"+CR	-
Pitch Up Start	"@12038"+CR	-
Pitch Up Stop	"@1203801"+CR	-
Pitch Down Start	"@12039"+CR	-
Pitch Down Stop	"@1203901"+CR	-
Program	"@12036"+CR	"@12636"+CR
AMS	"@12043"+CR	"@12643"+CR
Pause	"@12048"+CR	"@12648"+CR
Cancel/Delete	"@12049"+CR	"@12649"+CR
Fast Backward Start	"@12050"+CR	"@12650"+CR
Fast Backward Stop	"@1205001"+CR	"@1265001"+CR
Fast Forward Start	"@12052"+CR	"@12652"+CR
Fast Forward Stop	"@1205201"+CR	"@1265201"+CR
Play	"@12053"+CR	"@12653"+CR
Stop	"@12054"+CR	"@12654"+CR
Random	"@12028"+CR	"@12647"+CR
Store/Menu	"@12082"+CR	"@12642"+CR
Enter	"@12087"+CR	"@12687"+CR
Select CD	"@12063"+CR	-
Select CDR	-	"@12663"+CR
Track Inc.	-	"@126114"+CR

• **Status request commands**

The following status request commands are received to confirm the current status, the status information is transmitted

Request Command for CD		Response from CD	
Power	"@1?20POWE"+CR	Power On	"@120PRON"+CR
Tray Mode	"@1?20TRAY"+CR	Open	"@120OPEN"+CR
		Close	"@120CLOS"+CR
Play Mode	"@1?20PLAY"+CR	Toc Reading	"@120TOCR"+CR
		Stop	"@120STOP"+CR
		Play	"@120PLAY"+CR
		Pause	"@120PASE"+CR
		FF	"@120FASF"+CR
		REW	"@120FASR"+CR
Disc	"@1?20DISC"+CR	No Disc	"@120NODI"+CR
		ERROR	"@120ERDI"+CR
		CDDA	"@120CDDI"+CR
		MP3	"@120MPDI"+CR
Repeat Mode	"@1?20RPTM"+CR	OFF	"@120RTOF"+CR
		ONE	"@120RTON"+CR
		ALL	"@120RTAL"+CR
Time Mode	"@1?20TMOD"+CR	Track	"@120TTRA"+CR
		Track Rem	"@120TTRE"+CR
		Total Rem	"@120TREM"+CR
		Total Lap	"@120TTLA"+CR
Album	"@1?20ALBU"+CR		"@120Axxx"+CR
Track	"@1?20TRAC"+CR		"@120Txxx"+CR
Current Display Time	"@1?20TIME"+CR		"@120xxxx"+CR

Request Command for CDR		Response from CDR	
Power	"@1?26POWE"+CR	Power On	"@126PRON"+CR
Tray Mode	"@1?26TRAY"+CR	Open	"@126OPEN"+CR
		Close	"@126CLOS"+CR
Play Mode	"@1?26PLAY"+CR	Toc Reading	"@126TOCR"+CR
		Stop	"@126STOP"+CR
		Play	"@126PLAY"+CR
		Pause	"@126PASE"+CR
		FF	"@126FASF"+CR
		REW	"@126FASR"+CR
		Rec	"@126RECO"+CR
		Rec Pause	"@126RECP"+CR
Disc	"@1?26DISC"+CR	No Disc	"@126NODI"+CR
		ERROR	"@126ERDI"+CR
		CDDA	"@126CDDI"+CR
Repeat Mode	"@1?26RPTM"+CR	OFF	"@126RTOF"+CR
		ONE	"@126RTON"+CR
		ALL	"@126RTAL"+CR
Time Mode	"@1?26TMOD"+CR	Track	"@126TTRA"+CR
		Track Rem	"@126TTRE"+CR
		Total Rem	"@126TREM"+CR
		Total Lap	"@126TTLA"+CR
Track	"@1?26TRAC"+CR		"@126Txxx"+CR
Current Display Time	"@1?26TIME"+CR		"@126xxxx"+CR

• **Status transmission**

The status packets have a fixed data length of 8 bytes. ASCII codes from 0x00 to 0x7f are used to transmit serial data. For this reason, the ASCII codes are converted into HEX data before the data is set in the data packets and transmitted. CR (0x0d) is added as the data packet delimiter.

Example 1: "Power On" (code @120PRON)

[@]	[1]	[2]	[0]	[P]	[R]	[0]	[N]	[CR]
0x40	0x31	0x32	0x30	0x50	0x57	0x4f	0x4e	0x0d

Transmitted status data

Category	Status from CD	
Power	Power On	"@120PRON"+CR
Tray Mode	Open	"@120OPEN"+CR
	Close	"@120CLOS"+CR
Play Mode	Toc Reading	"@120TOCR"+CR
	Stop	"@120STOP"+CR
	Play	"@120PLAY"+CR
	Pause	"@120PASE"+CR
	FF	"@120FASF"+CR
	REW	"@120FASR"+CR
Disc	No Disc	"@120NODI"+CR
	ERROR	"@120ERDI"+CR
	CDDA	"@120CDDI"+CR
	MP3	"@120MPDI"+CR
Repeat Mode	OFF	"@120RTOF"+CR
	ONE	"@120RTON"+CR
	ALL	"@120RTAL"+CR
Time Mode	Track	"@120TTRA"+CR
	Track Rem	"@120TTRE"+CR
	Total Rem	"@120TREM"+CR
	Total Lap	"@120TTLA"+CR

Category	Status from CDR	
Power	Standby	"@126POFF"+CR
	Power On	"@126PRON"+CR
Tray Mode	Open	"@126OPEN"+CR
	Close	"@126CLOS"+CR
Play Mode	Toc Reading	"@126TOCR"+CR
	Stop	"@126STOP"+CR
	Play	"@126PLAY"+CR
	Pause	"@126PASE"+CR
	FF	"@126FASF"+CR
	REW	"@126FASR"+CR
	Rec	"@126RECO"+CR
	Rec Pause	"@126RECP"+CR
Disc	No Disc	"@126NODI"+CR
	ERROR	"@126ERDI"+CR
	CDDA	"@126CDDI"+CR
Repeat Mode	OFF	"@126RTOF"+CR
	ONE	"@126RTON"+CR
	ALL	"@126RTAL"+CR
Time Mode	Track	"@126TTRA"+CR
	Track Rem	"@126TTRE"+CR
	Total Rem	"@126TREM"+CR
	Total Lap	"@126TTLA"+CR

## ■ RS232C 端子の使い方

RS232C 外部コントロール用 (D-SUB 9ピン・メス) の入出力端子です。

市販のストレートケーブルを接続して、外部コントロールおよびステータス情報の送信ができます。

### • コネクタ・ピンアサイン

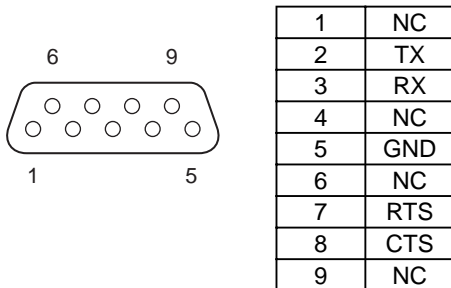

### • RS232C 接続

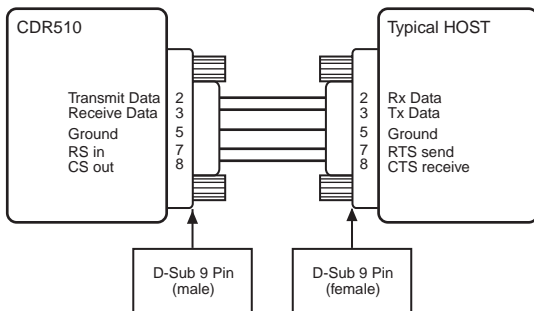

RS232C 接続は、9ピン (メス) 対 9ピン (オス) のストレートケーブルによる接続が必要です。

### • RS232C 物理仕様

Cable	Straight cable
Baud rate	9600 bps
Data bits	8 bits
Parity bit	None
Stop bit	1 bit
Flow control	CS/RS Hardware Flow

#### CS/RS Hardware Flow Control

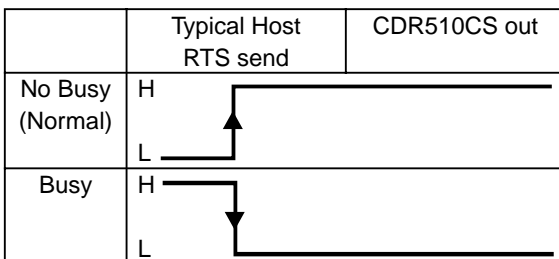

#### Timing chart

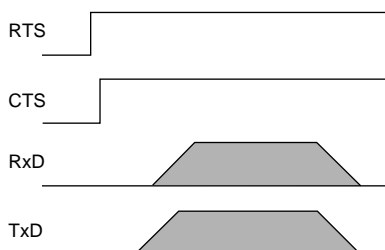

### • コマンド受信

コマンドパケットのデータ長は7～10バイトです。シリアルデータ受信に使われるコードは、0x00～0x7fまでのASCIIコードです。そのため送信側はASCIIコードをHEXデータに変換してデータパケットにセットしてください。またデータパケットの区切りにはCR (0x0d) を付加してください。

コマンドを連続して送信する場合は各コマンド間を100ms以上あけてください。

Example: "0" (code @12000)

[@]	[1]	[2]	[0]	[0]	[0]	[CR]
0x40	0x31	0x32	0x30	0x30	0x30	0x0d

コマンドを連続して送信する場合は各コマンド間を100ms以上あけてください。

#### コマンド受信データ

Request Command	CD Command	CDR Command
0	"@12000"+CR	"@12600"+CR
1	"@12001"+CR	"@12601"+CR
2	"@12002"+CR	"@12602"+CR
3	"@12003"+CR	"@12603"+CR
4	"@12004"+CR	"@12604"+CR
5	"@12005"+CR	"@12605"+CR
6	"@12006"+CR	"@12606"+CR
7	"@12007"+CR	"@12607"+CR
8	"@12008"+CR	"@12608"+CR
9	"@12009"+CR	"@12609"+CR
Display	"@12015"+CR	"@12615"+CR
Scroll	"@12011"+CR	"@12611"+CR
Repeat	"@12029"+CR	"@12629"+CR
Next	"@12032"+CR	"@12632"+CR
Previous	"@12033"+CR	"@12633"+CR
Pitch Reset	"@12037"+CR	-
Pitch Up Start	"@12038"+CR	-
Pitch Up Stop	"@1203801"+CR	-
Pitch Down Start	"@12039"+CR	-
Pitch Down Stop	"@1203901"+CR	-
Program	"@12036"+CR	"@12636"+CR
AMS	"@12043"+CR	"@12643"+CR
Pause	"@12048"+CR	"@12648"+CR
Cancel/Delete	"@12049"+CR	"@12649"+CR
Fast Backward Start	"@12050"+CR	"@12650"+CR
Fast Backward Stop	"@1205001"+CR	"@1265001"+CR
Fast Forward Start	"@12052"+CR	"@12652"+CR
Fast Forward Stop	"@1205201"+CR	"@1265201"+CR
Play	"@12053"+CR	"@12653"+CR
Stop	"@12054"+CR	"@12654"+CR
Random	"@12028"+CR	"@12647"+CR
Store/Menu	"@12082"+CR	"@12642"+CR
Enter	"@12087"+CR	"@12687"+CR
Select CD	"@12063"+CR	-
Select CDR	-	"@12663"+CR
Track Inc.	-	"@126114"+CR

• ステータス リクエスト コマンド

ステータス リクエスト コマンド受信し、現在の状態を確認しステータス情報を送信します。

Request Command for CD		Response from CD	
Power	"@1?20POWE"+CR	Power On	"@120PRON"+CR
Tray Mode	"@1?20TRAY"+CR	Open	"@120OPEN"+CR
		Close	"@120CLOS"+CR
Play Mode	"@1?20PLAY"+CR	Toc Reading	"@120TOCR"+CR
		Stop	"@120STOP"+CR
		Play	"@120PLAY"+CR
		Pause	"@120PASE"+CR
		FF	"@120FASF"+CR
		REW	"@120FASR"+CR
Disc	"@1?20DISC"+CR	No Disc	"@120NODI"+CR
		ERROR	"@120ERDI"+CR
		CDDA	"@120CDDI"+CR
		MP3	"@120MPDI"+CR
Repeat Mode	"@1?20RPTM"+CR	OFF	"@120RTOF"+CR
		ONE	"@120RTON"+CR
Time Mode	"@1?20TMOD"+CR	ALL	"@120RTAL"+CR
		Track	"@120TTRA"+CR
		Track Rem	"@120TTRE"+CR
		Total Rem	"@120TREM"+CR
Album	"@1?20ALBU"+CR		"@120Axxx"+CR
Track	"@1?20TRAC"+CR		"@120Txxx"+CR
Current Display Time	"@1?20TIME"+CR		"@120xxxx"+CR

Request Command for CDR		Response from CDR	
Power	"@1?26POWE"+CR	Power On	"@126PRON"+CR
Tray Mode	"@1?26TRAY"+CR	Open	"@126OPEN"+CR
		Close	"@126CLOS"+CR
Play Mode	"@1?26PLAY"+CR	Toc Reading	"@126TOCR"+CR
		Stop	"@126STOP"+CR
		Play	"@126PLAY"+CR
		Pause	"@126PASE"+CR
		FF	"@126FASF"+CR
		REW	"@126FASR"+CR
Disc	"@1?26DISC"+CR	Rec	"@126RECO"+CR
		Rec Pause	"@126RECP"+CR
		No Disc	"@126NODI"+CR
Repeat Mode	"@1?26RPTM"+CR	ERROR	"@126ERDI"+CR
		CDDA	"@126CDDI"+CR
		OFF	"@126RTOF"+CR
Time Mode	"@1?26TMOD"+CR	ONE	"@126RTON"+CR
		ALL	"@126RTAL"+CR
		Track	"@126TTRA"+CR
		Track Rem	"@126TTRE"+CR
Track	"@1?26TRAC"+CR	Total Rem	"@126TREM"+CR
		Total Lap	"@126TTLA"+CR
Current Display Time	"@1?26TIME"+CR		"@126xxxx"+CR

• ステータス送信

ステータスパケットのデータ長は 8 バイト固定です。シリアルデータ送信に使われるコードは 0x00 ~ 0x7f までの ASCII コードです。そのため ASCII コードを HEX データに変換してデータパケットにセットし送信します。またデータパケットの区切りには CR(0x0d) が付加されます。

Example 1: "Power On" (code @120PRON)

[@]	[1]	[2]	[0]	[P]	[R]	[O]	[N]	[CR]
0x40	0x31	0x32	0x30	0x50	0x57	0x4f	0x4e	0x0d

ステータス送信データ

Category	Status from CD
Power	Power On "@120PRON"+CR
Tray Mode	Open "@120OPEN"+CR
	Close "@120CLOS"+CR
Play Mode	Toc Reading "@120TOCR"+CR
	Stop "@120STOP"+CR
	Play "@120PLAY"+CR
	Pause "@120PASE"+CR
	FF "@120FASF"+CR
	REW "@120FASR"+CR
Disc	No Disc "@120NODI"+CR
	ERROR "@120ERDI"+CR
	CDDA "@120CDDI"+CR
	MP3 "@120MPDI"+CR
Repeat Mode	OFF "@120RTOF"+CR
	ONE "@120RTON"+CR
	ALL "@120RTAL"+CR
Time Mode	Track "@120TTRA"+CR
	Track Rem "@120TTRE"+CR
	Total Rem "@120TREM"+CR
	Total Lap "@120TTLA"+CR

Category	Status from CDR
Power	Standby "@126POFF"+CR
	Power On "@126PRON"+CR
Tray Mode	Open "@126OPEN"+CR
	Close "@126CLOS"+CR
Play Mode	Toc Reading "@126TOCR"+CR
	Stop "@126STOP"+CR
	Play "@126PLAY"+CR
	Pause "@126PASE"+CR
	FF "@126FASF"+CR
	REW "@126FASR"+CR
Disc	Rec "@126RECO"+CR
	Rec Pause "@126RECP"+CR
	No Disc "@126NODI"+CR
Repeat Mode	ERROR "@126ERDI"+CR
	CDDA "@126CDDI"+CR
	OFF "@126RTOF"+CR
Time Mode	ONE "@126RTON"+CR
	ALL "@126RTAL"+CR
	Track "@126TTRA"+CR
	Track Rem "@126TTRE"+CR
Track	Total Rem "@126TREM"+CR
	Total Lap "@126TTLA"+CR

## 6. SERVICE PROCEDURE

### • Emergency Eject (CD)

1. To open the stucked tray, push the eject lever.
2. Use a pin  $\varnothing 4\text{mm}$  or less.

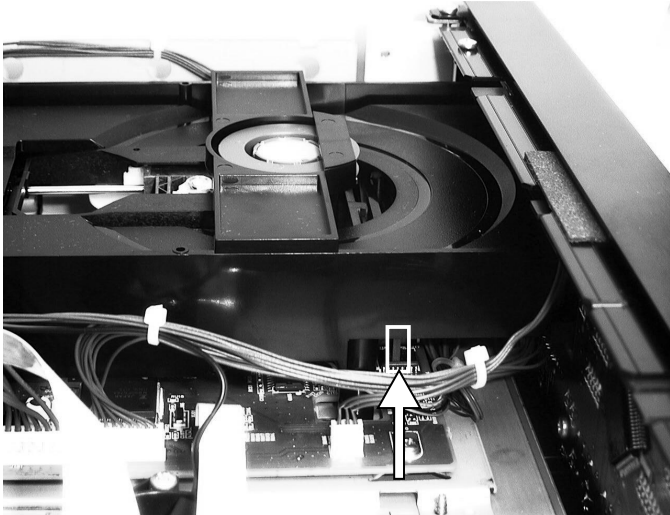

This picture shows the unit upside down. The eject lever is pointed by the arrow.

The lever is thin so aim the narrow area carefully.

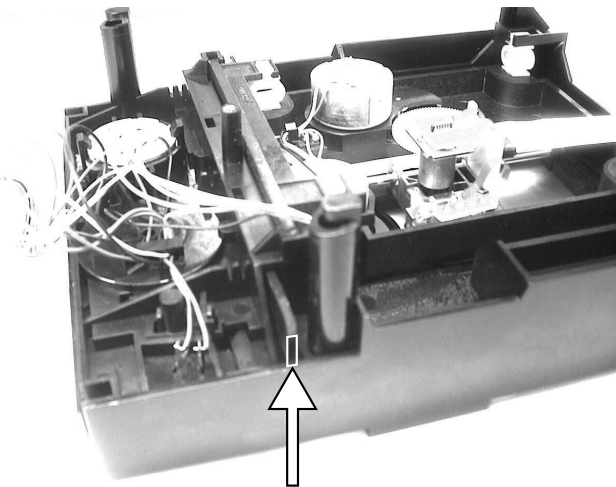

### • Emergency Eject (CD-R)

1. To open the tray when it is stuck, insert a pin into the eject pinhole and push.
2. Use a pin  $\varnothing 4\text{mm}$  or less.

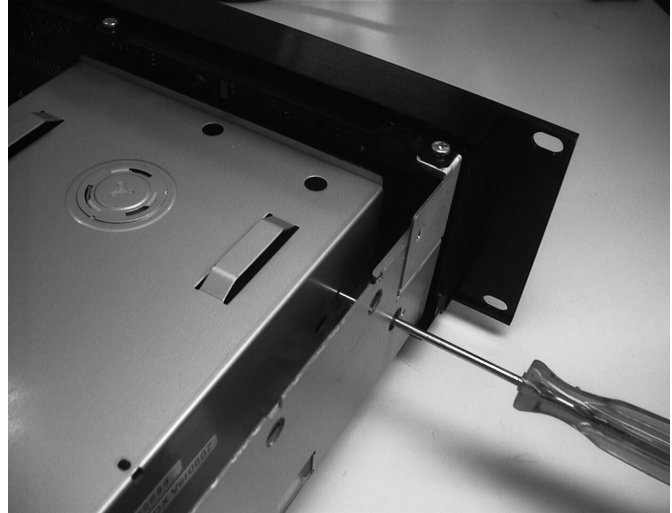

### • Replacing the Mechanism Assy (CD-R)

1. Open the tray first.
2. Remove the 3 screws shown in the picture below.
3. Disconnect all the wires at the right side.
4. Replace the MECHANISM ASSY(001M).

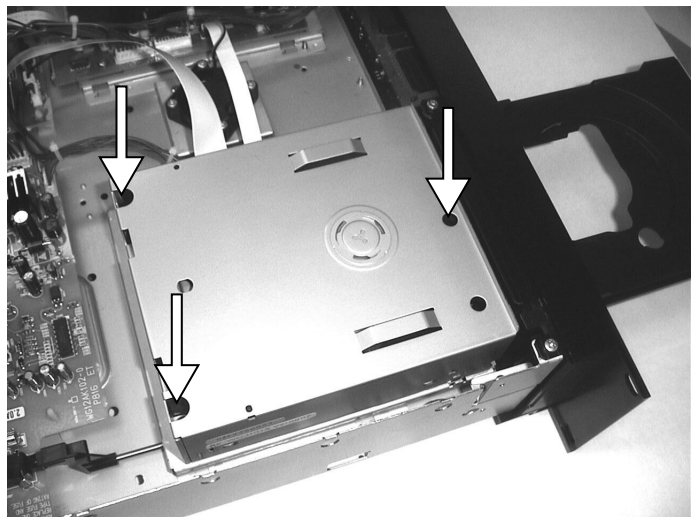

- **Cautions in Assembling and Disassembling**

When removing the flat wire, connecting the optical pick up and the CD decoder board, short-cut the two lands pointed by the arrow with solder. Otherwise the laser diode may be damaged by static electricity.

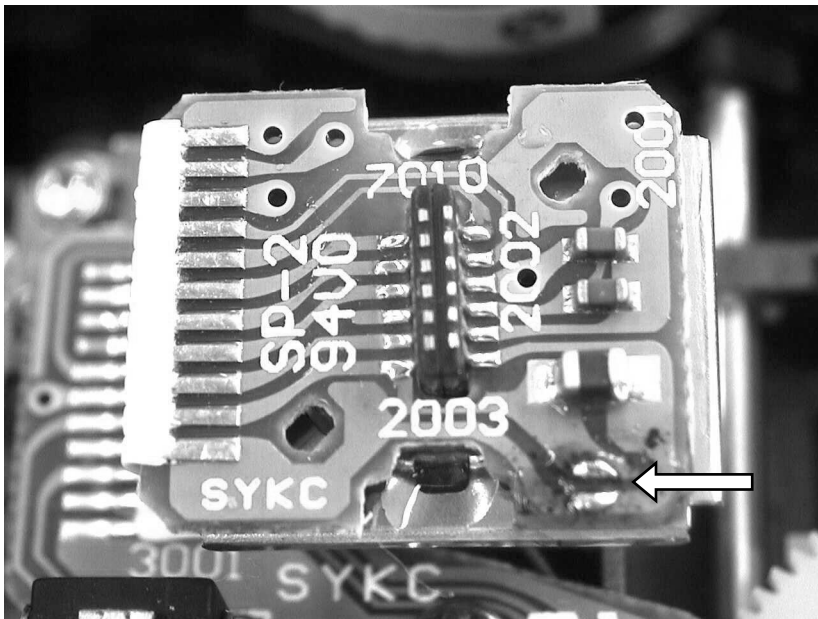

- **CD Decoder Board (PS01) Repair**

When Repairing the CD decoder board PS16, you can fix the board on the loader unit as shown in the picture below with the flat wires that are provided as service parts.

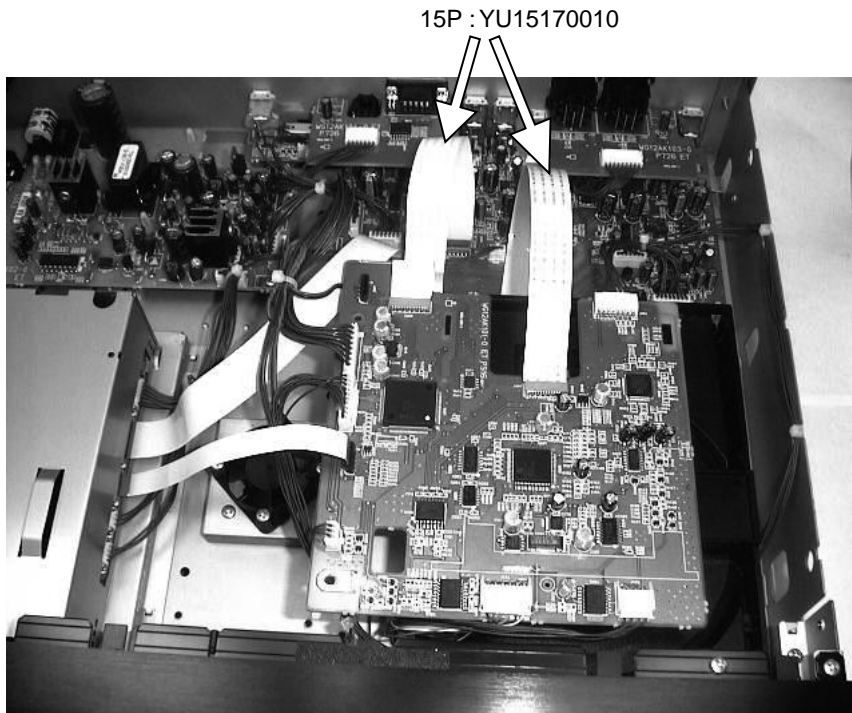

## 7. SERVICE MODE

### 1. Turning into Service Mode

While pressing **STOP**(CDR) and **PLAY/PAUSE**(CDR) buttons, press **POWER** button.

Mode0,1,2 and 3 are CD Player side.

### 2. Mode 0 (display "VER\_ \*-\*\* P00" )

Version number of The micro computer(QU01) is displayed (\*-\*\*).

Status: [FOCUS OFF], [SPINDLE OFF], [RADIAL OFF], [MUTE ON].

- While pressing ◀ or ▶ button, the sledge moves toward the outer edge. Release the button makes the sledge return to the origin.

Turn **REC LEVEL/SELECT** button clockwise to go to Mode 1.

### 3. Mode 1 (display "VER\_ \*-\*\* P01" )

Status: [FOCUS ON], [SPINDLE OFF], [RADIAL OFF], [MUTE ON]

Turn **REC LEVEL/SELECT** button clockwise to go to Mode 2.

### 4. Mode 2 (display "VER\_ \*-\*\* P02" )

Status: [FOCUS ON], [SPINDLE ON], [RADIAL OFF], [MUTE ON]

Turn **REC LEVEL/SELECT** button clockwise to go to Mode 3.

### 5. Mode 3 (display "VER\_ \*-\*\* P03" )

Status: [FOCUS ON], [SPINDLE ON], [RADIAL ON], [MUTE OFF]

When **REC LEVEL/SELECT** button is turned counterclockwise, Mode is returned to Mode 2, Mode 1, Mode0.

\* In this Service Mode, all of the following button functions work in any status.

- 1) Press **TEXT** button to light up all the FL segments.
- 2) Press **STOP** button(CD).Then press a button on the unit. The name of the button is displayed. Pressing a button on the remote displays the RC-5 code of the button.
- 3) Press **PLAY** button in the Mode1, 2 or 3 then normal operation can be performed. If an error occurs the error number is displayed. (EX : Err 10) See the table below.
- 4) Terminating Service Mode  
Turn off power to quit Service Mode.

## 7. サービスモード

### 1. サービスモードへの入り方

CDR 側の **STOP** と **PLAY/PAUSE** ボタンを押しながら **POWER** ボタンを押します。

モード 0、1、2、3 は CD 側のみです。

### 2. モード 0 (表示: VER\_ \* - \*\* P 0 0)

マイコン (QU01) の Ver. が表示 (\* - \*\*) されます。

状態: [FOCUS OFF] [SPINDLE OFF] [RADIAL OFF] [MUTE ON]

- ◀ または ▶ ボタンを押している間だけスレッドが外周へ移動します。ボタンを放すと原点に戻ります。

**REC LEVEL / SELECT** ボタンを右にまわすと、モード 1 へ移行します。

### 3. モード 1 (表示: VER\_ \* - \*\* P 0 1)

状態:[FOCUS ON] [SPINDLE OFF] [RADIAL OFF] [MUTE ON]

**REC LEVEL / SELECT** ボタンを右にまわすと、モード 2 へ移行します。

### 4. モード 2 (表示: VER\_ \* - \*\* P 0 2)

状態:[FOCUS ON] [SPINDLE ON] [RADIAL OFF] [MUTE ON]

**REC LEVEL / SELECT** を右にまわすと、モード 3 へ移行します。

### 5. モード 3 (表示: VER\_ \* - \*\* P 0 3)

状態:[FOCUS ON] [SPINDLE ON] [RADIAL ON] [MUTE OFF]

**REC LEVEL / SELECT** ボタンを左にまわすと、モード 2、モード 1、モード 0 に戻ります。

\* サービスモードの全ての状態で以下のボタンが有効です。

- 1) **TEXT** ボタンを押すと FL が全点灯します。
- 2) CD 側の **STOP** ボタンを押し、更に本体のボタンを押すとボタンの名前が表示されます。リモコンのボタンを押すと RC-5 コードが表示されます。
- 3) モード 1、2、3 の状態で **PLAY** ボタンを押すと通常と同じ動作となります。ただし、動作中、異常が確認された時にエラー番号が表示されます。(例: Err 10) 下記の表を参考にしてください。
6. サービスモードの解除  
電源を切るとサービスモードが解除されます。

Error Code	Error
Err 02	FOCUS Error
Err 07	SUB CODE Error
Err 08	T. O. C. Error
Err 09	DECODER Error
Err 10	RADIAL Error
Err 11, 12	SLEDGE Error
Err 13	SPINDLE Error
Err 16 ~ 20	SEARCH Error
Err 30	DOOR Error
Err 31	TRAY Error
Err 32 ~ 47	BUTTON INPUT Error



# 8. WIRING DIAGRAM

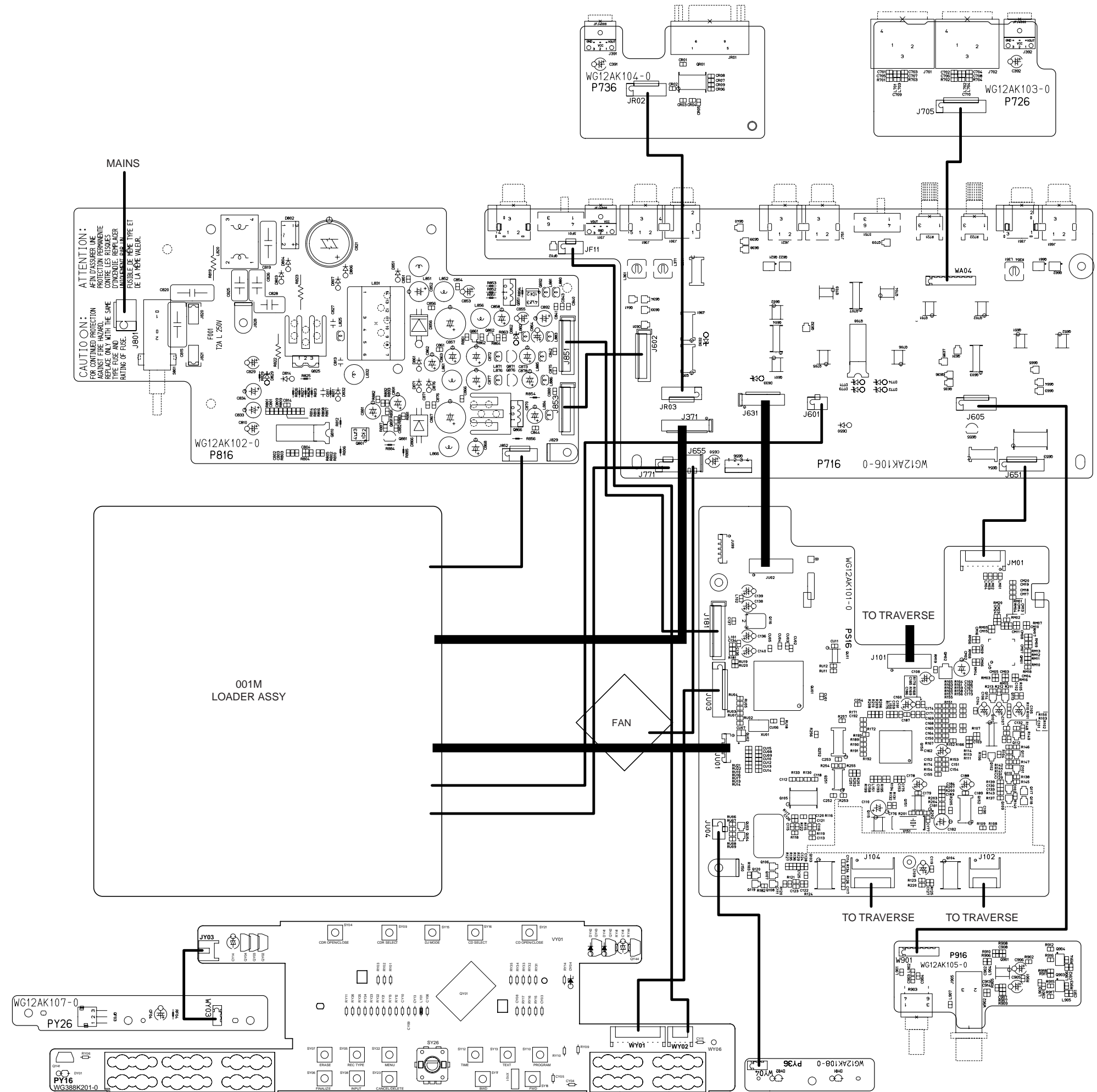

9. BLOCK DIAGRAM

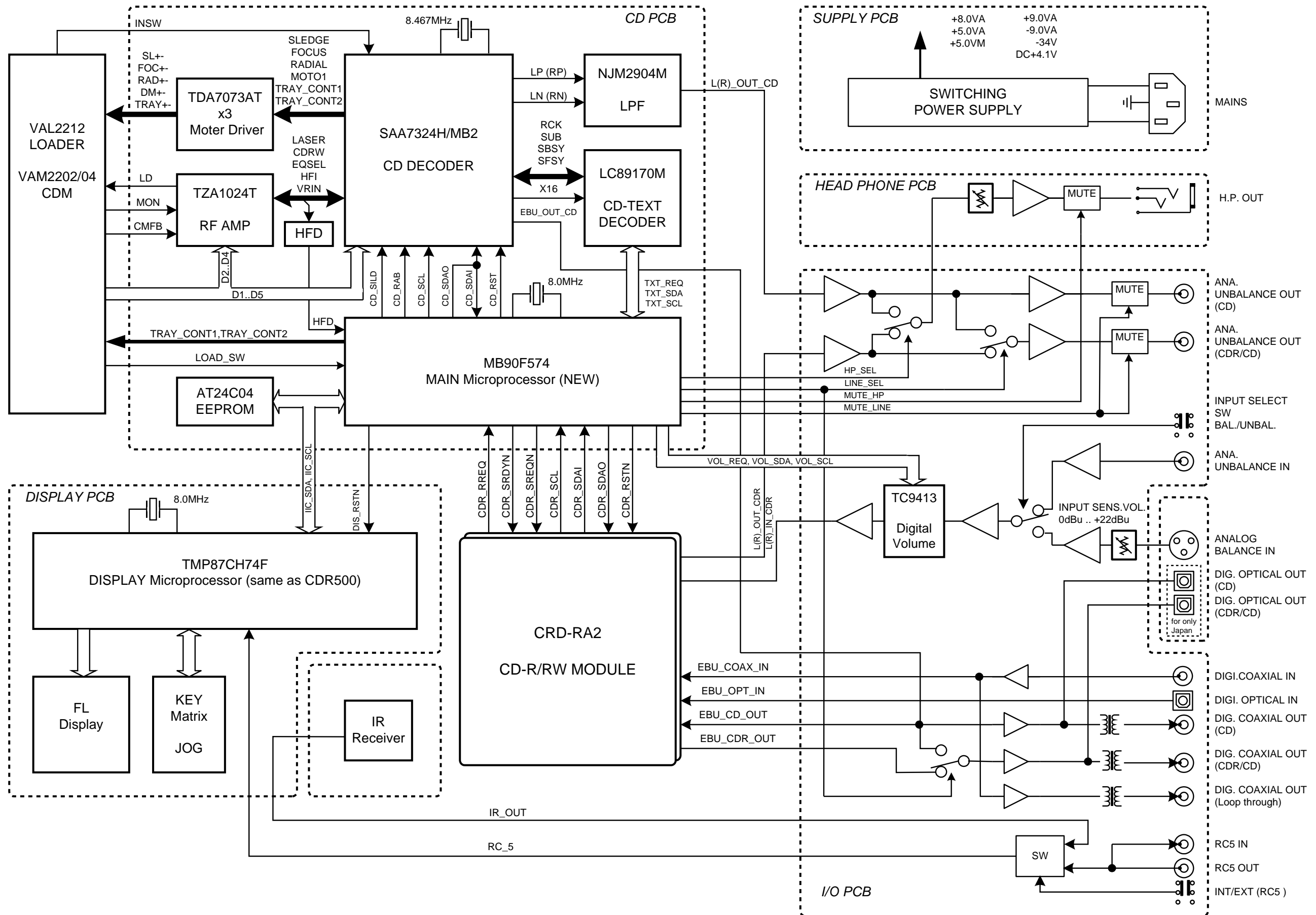

# 10. SCHEMATIC DIAGRAM

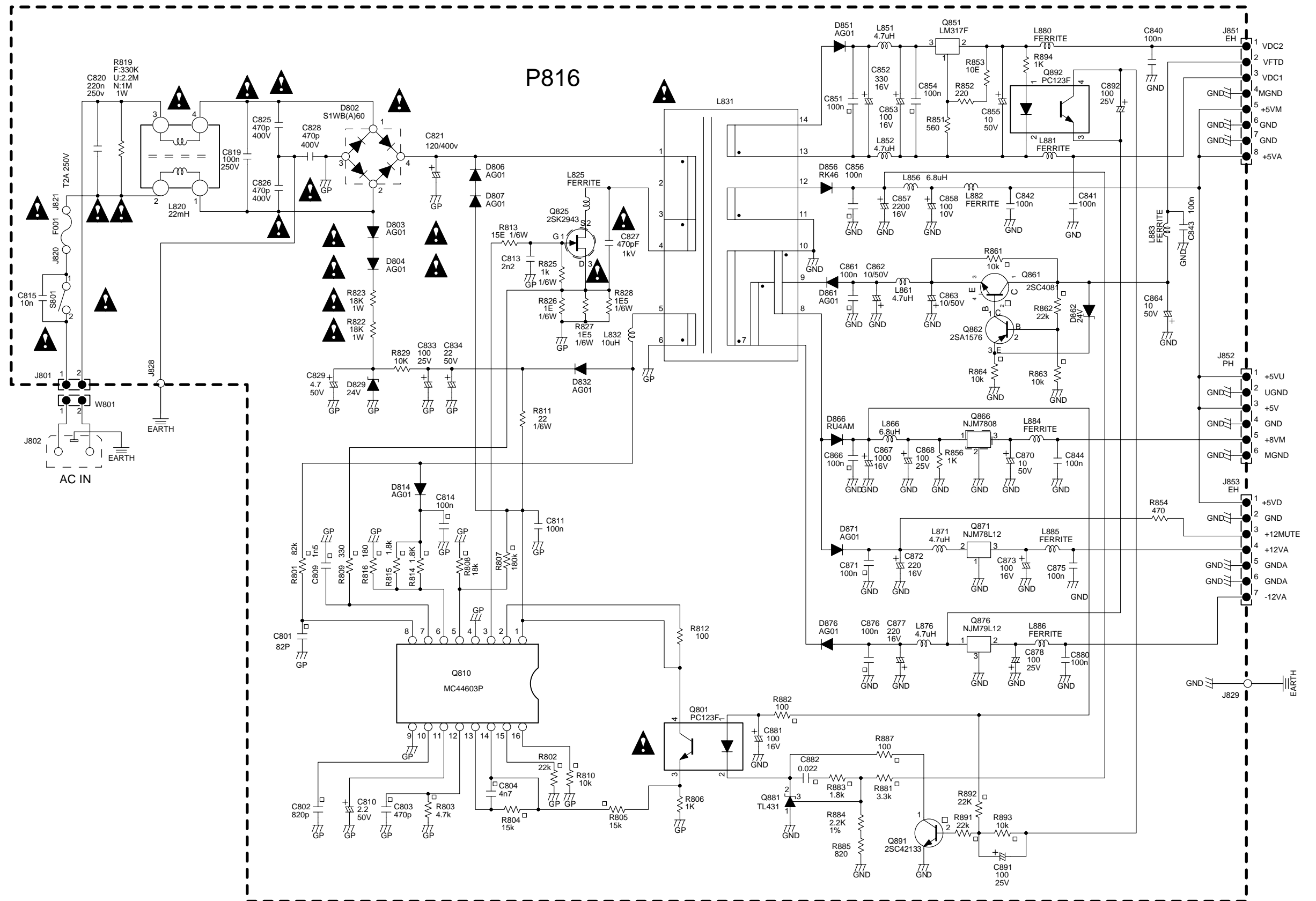

"NOTE ON SAFETY: The parts marked with  are IMPORTANT PARTS on the safety.  
Please use the parts having the designated parts number without fail"

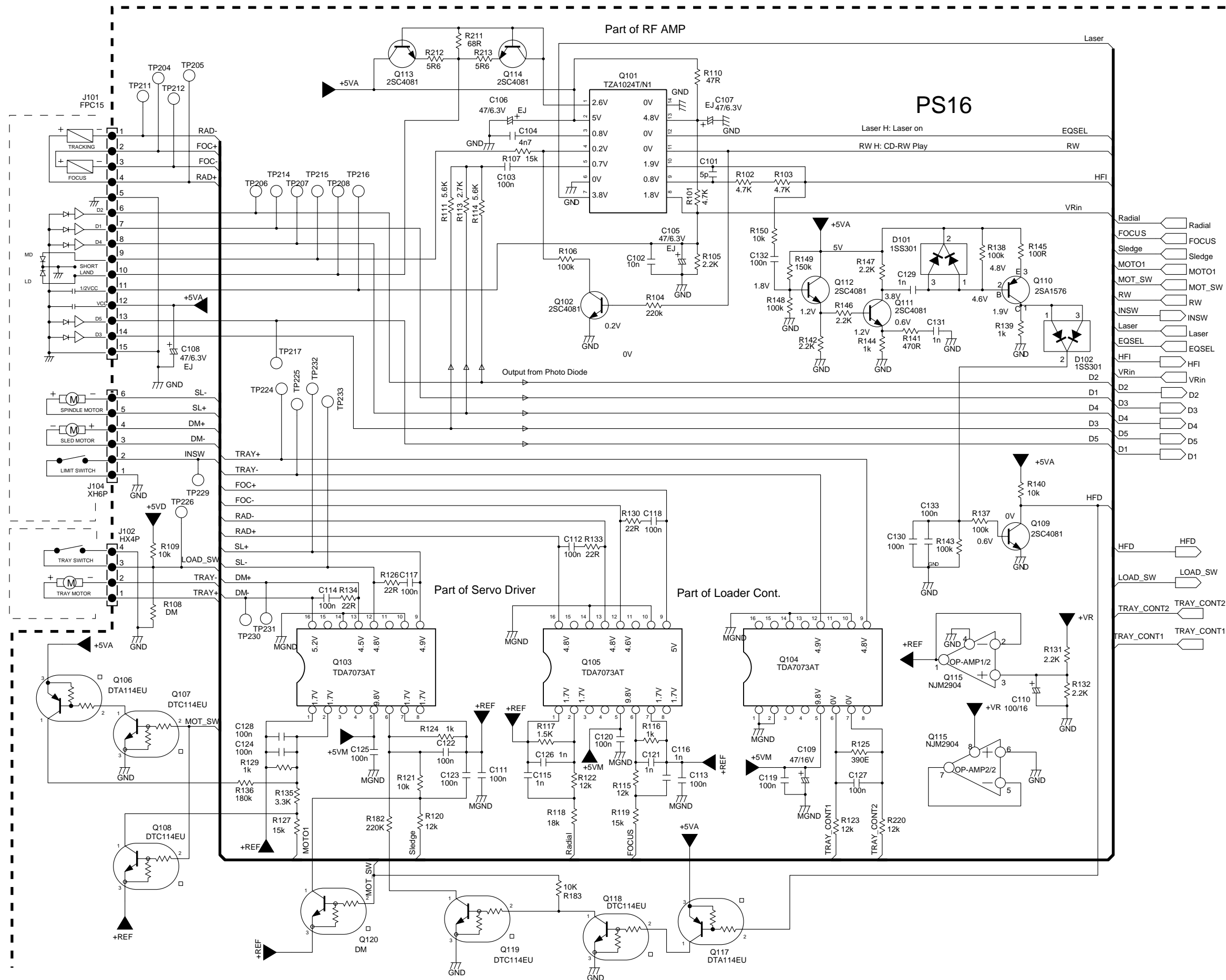

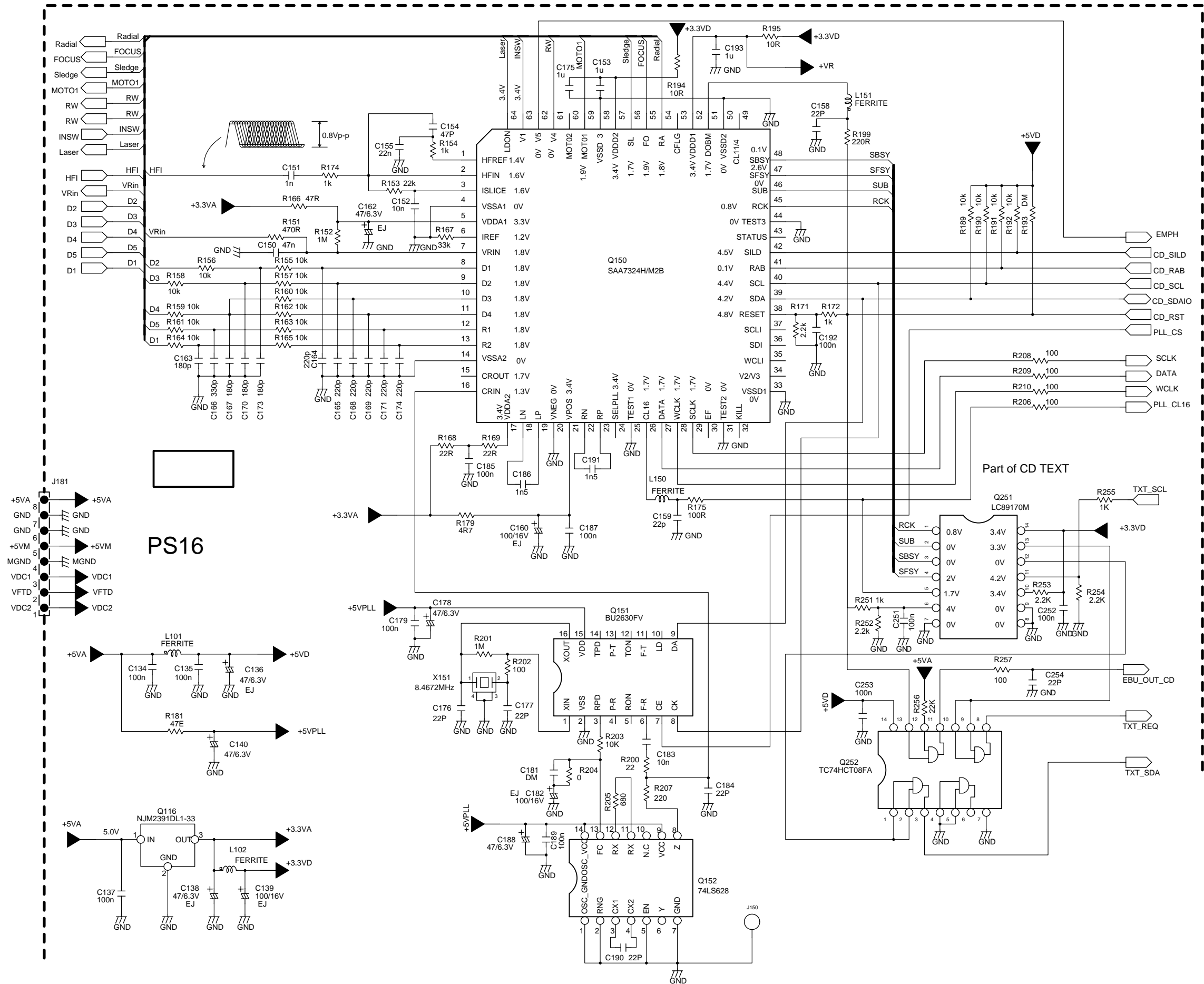

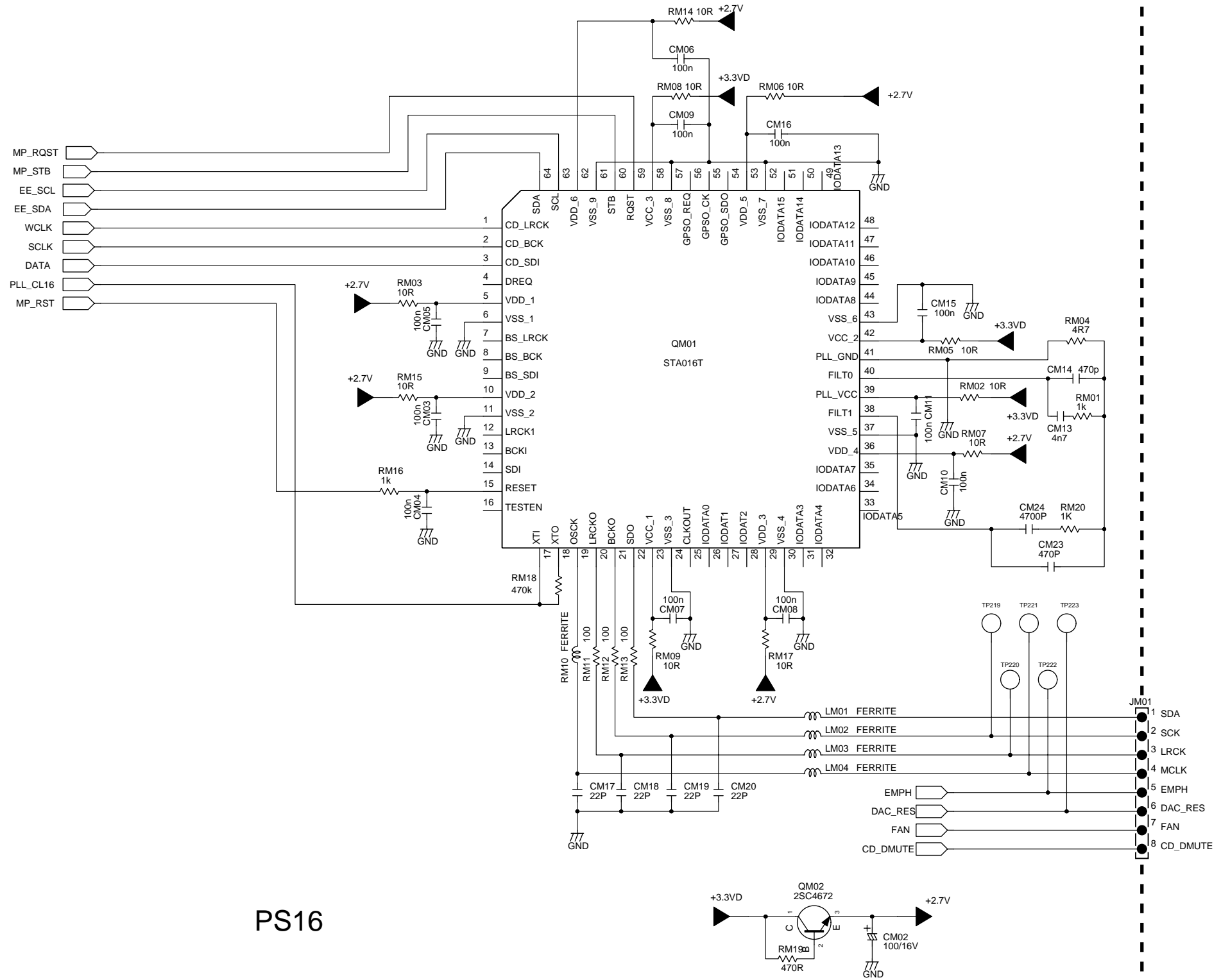

PS16

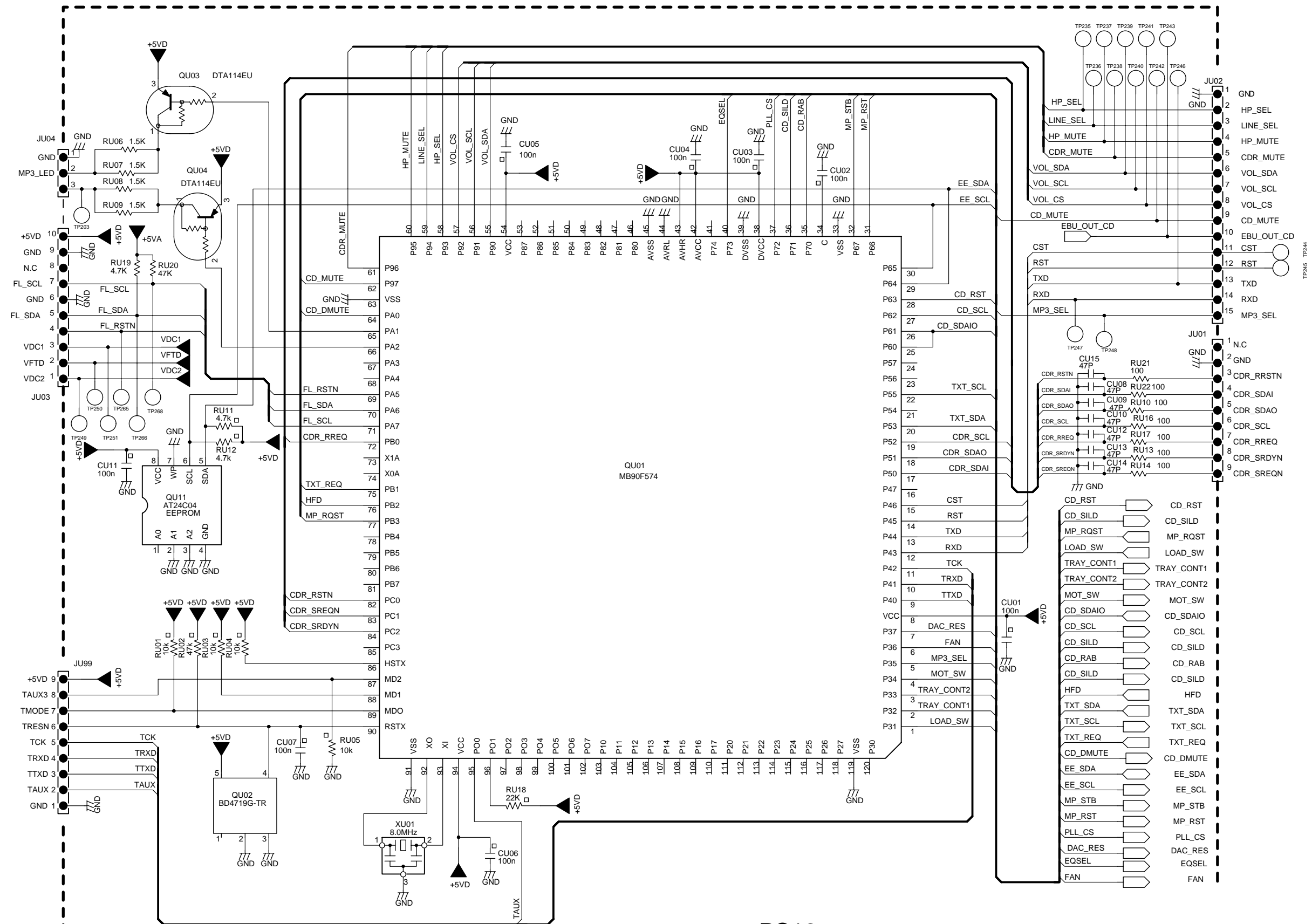

PS16





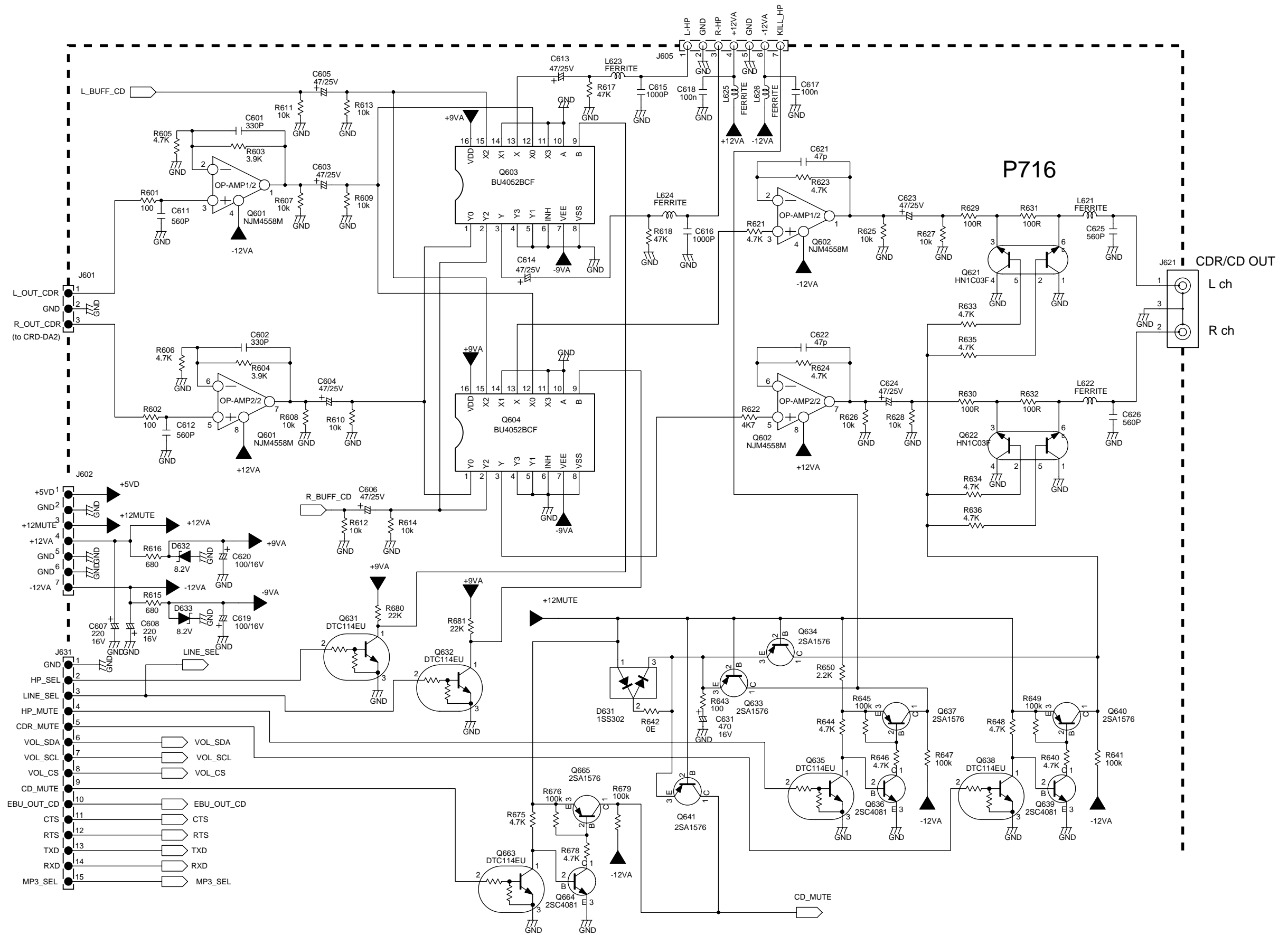

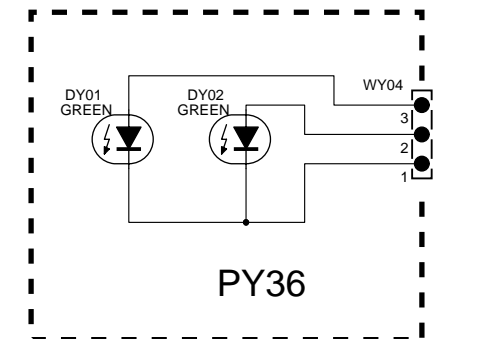
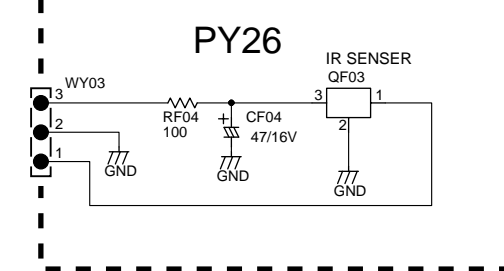
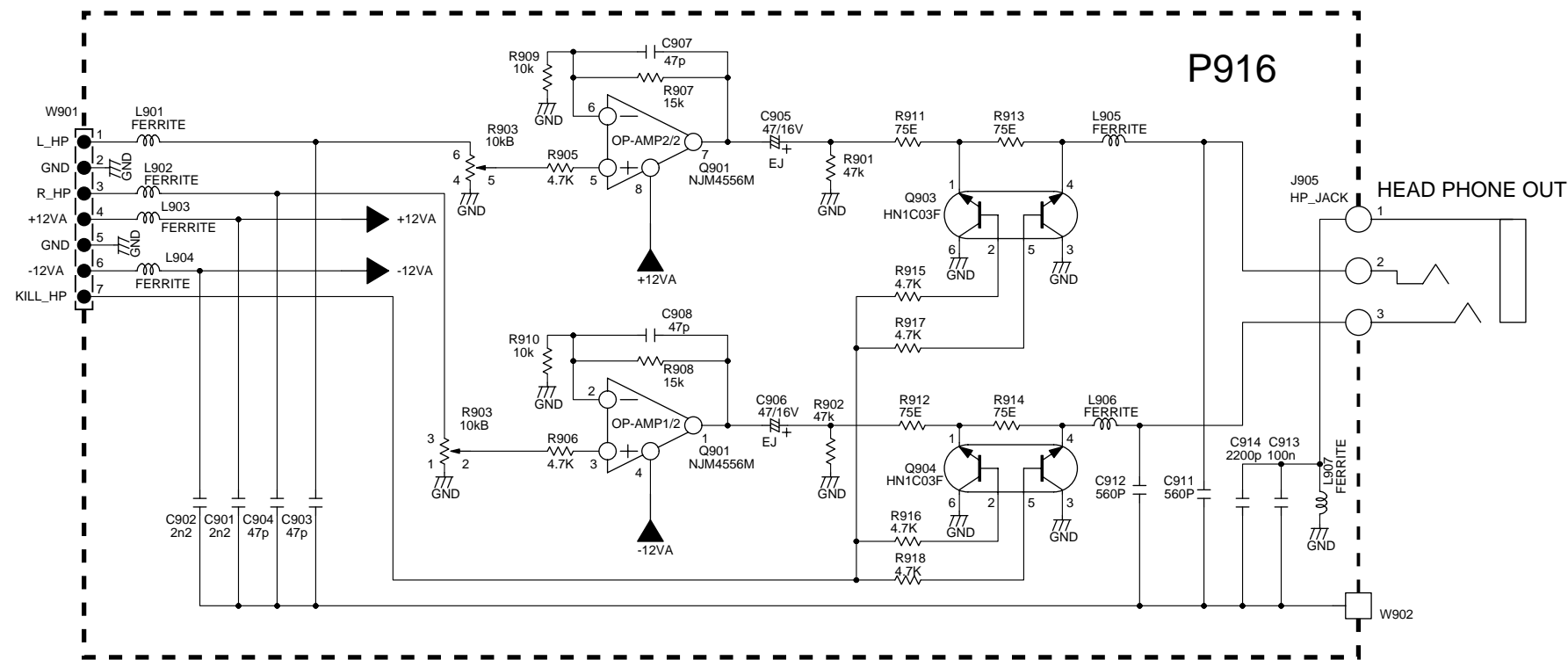
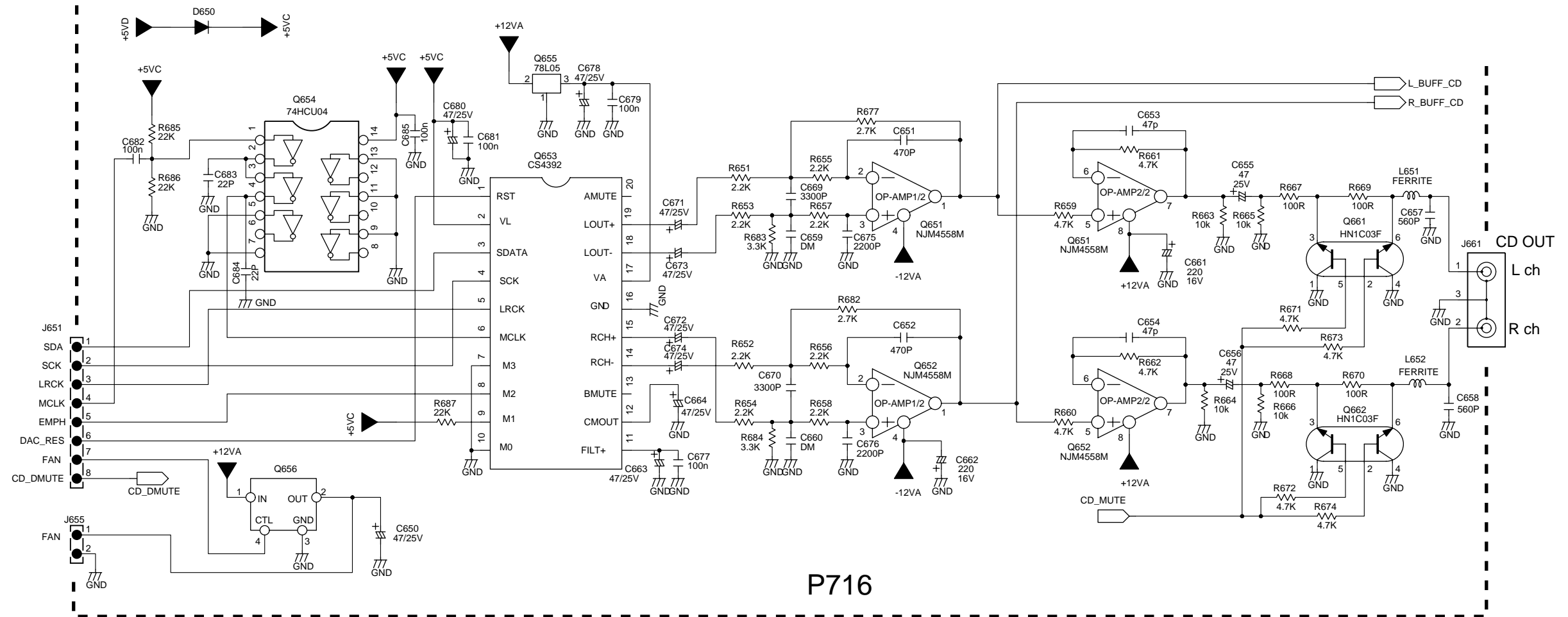

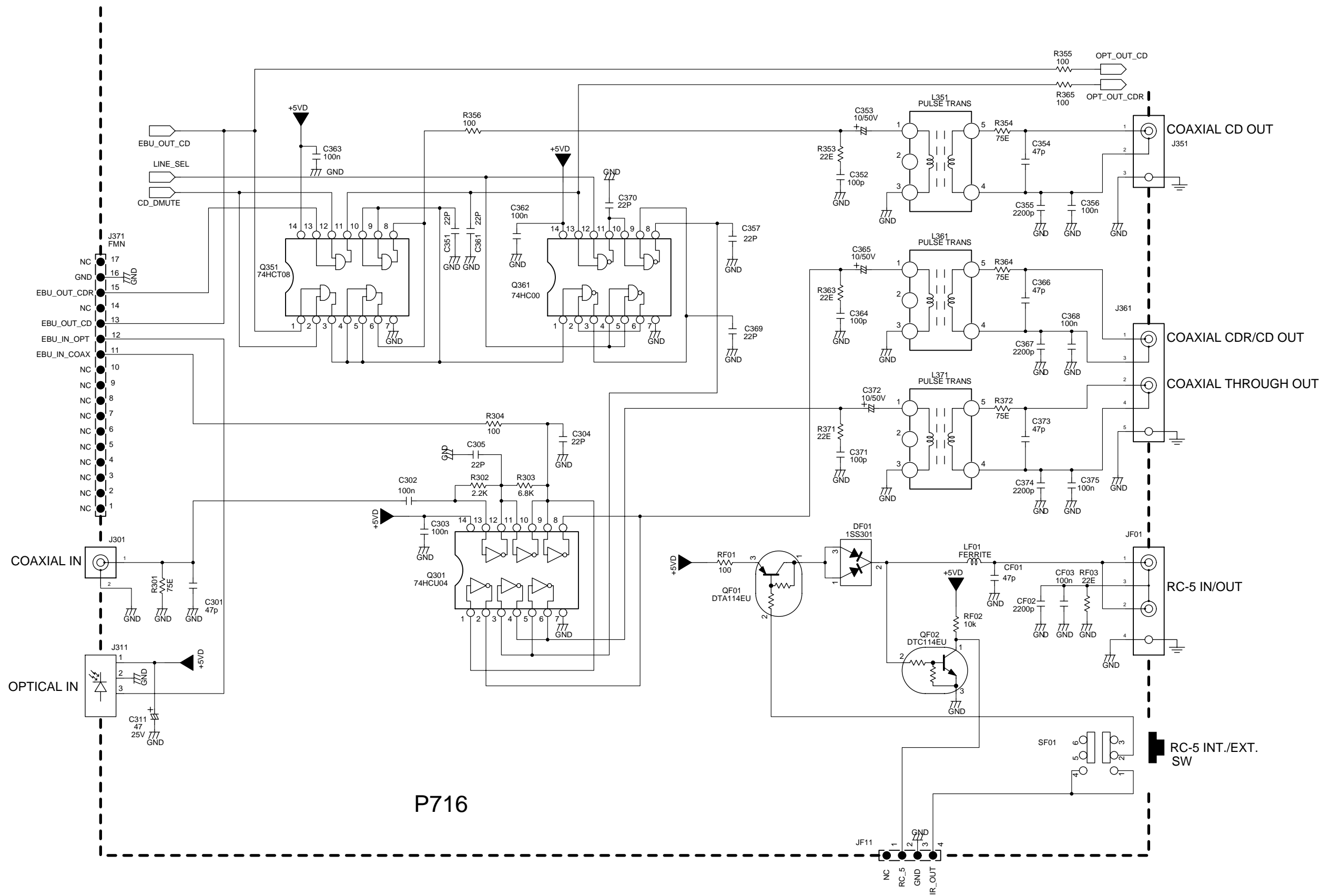

P716

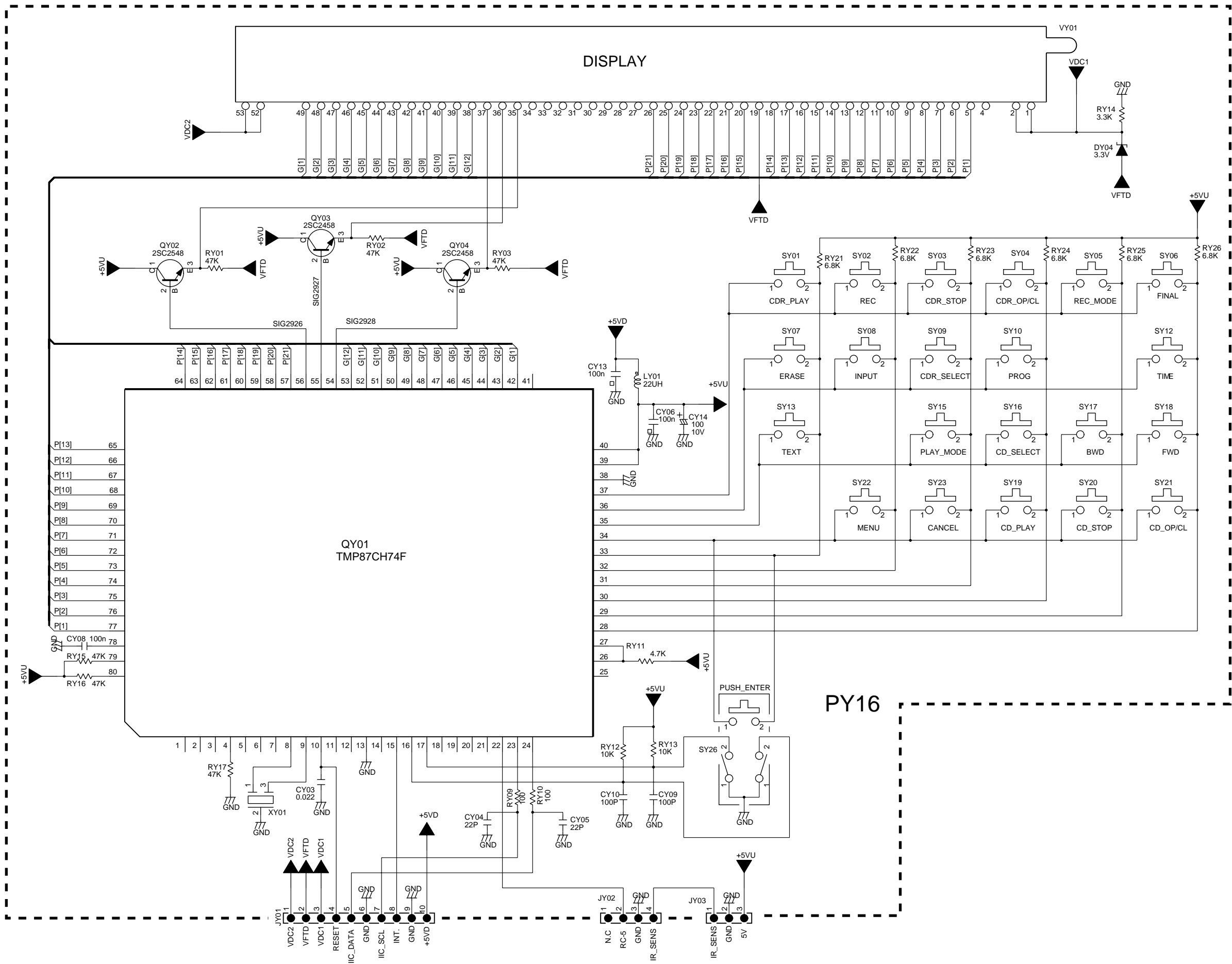



P716

Q653 Q654 Q655  
 Q663 - Q665 Q635 - Q637  
 Q652 Q651 Q603 Q631 Q706 Q708 Q705 Q632 Q601 Q604 Q351 Q361  
 Q662 Q661 Q702 Q701 Q704 Q707 Q703 Q602 Q633 Q634 Q641  
 Q622 Q621 Q638 - Q640 Q301 QF02 QF01

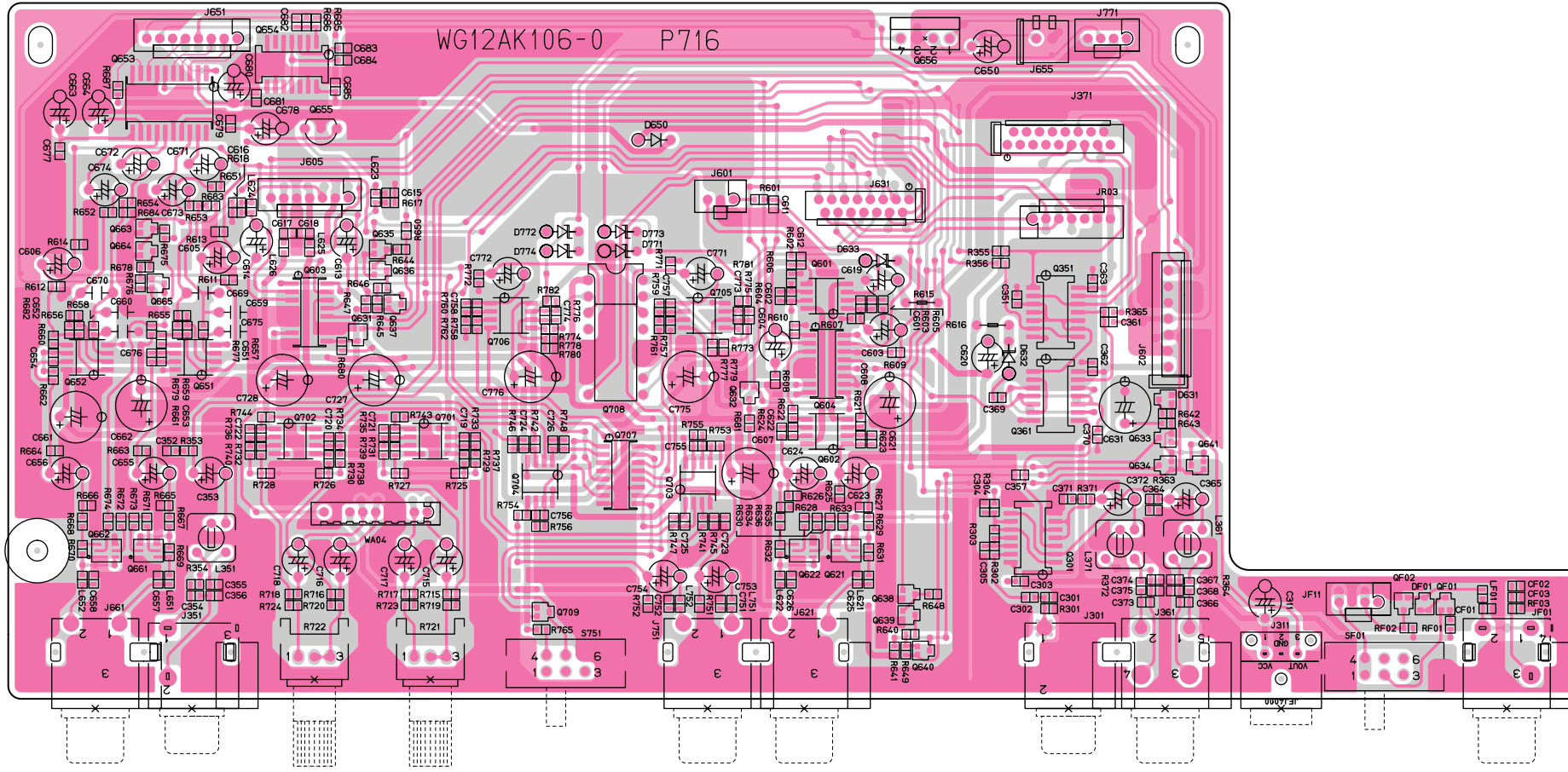

Q851 Q892  
 Q861 862 Q871 Q876  
 Q866

Q825  
 Q810  
 Q801 Q891 Q881

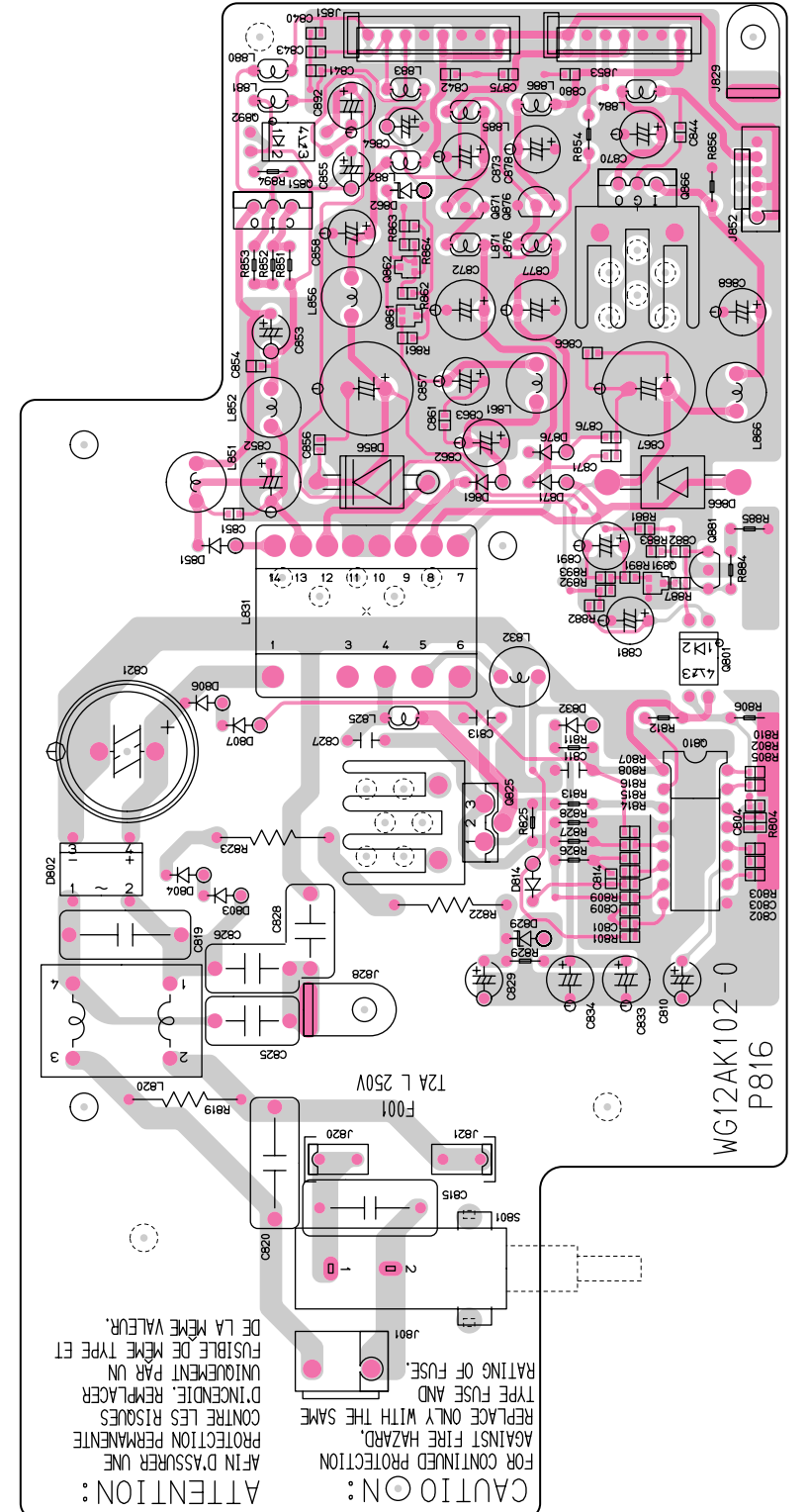

P816

PY16

QY04-QY02

QY01

QY42-QY44

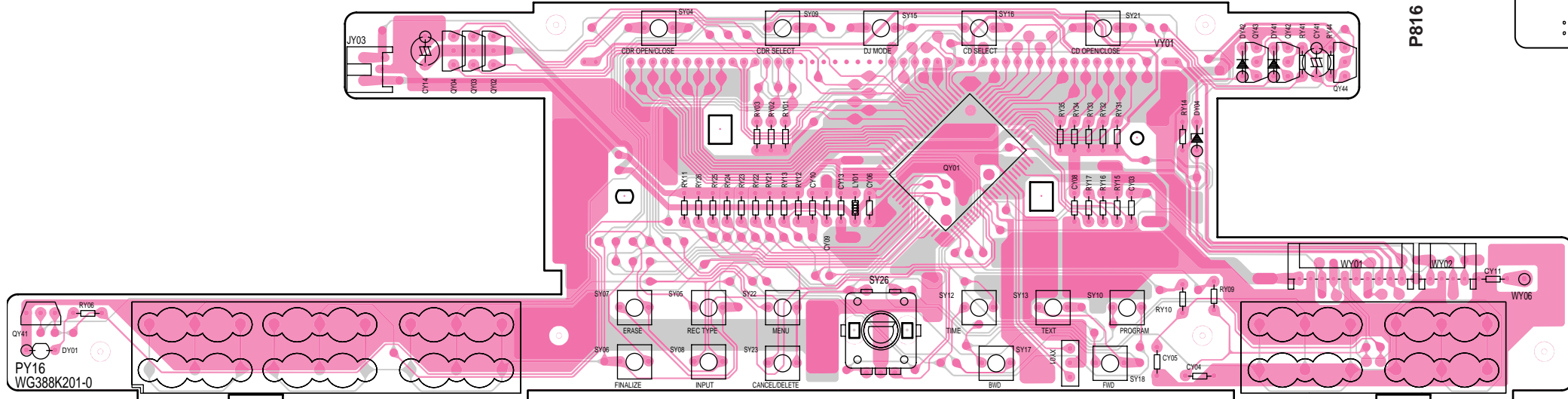

PY36

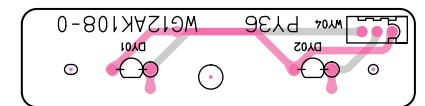

## 12. IC DATA

### Q101 : TZA1024

Pin Description

SYMBOL	PIN	DESCRIPTION
LD	1	current output to laser diode
VDD(L)	2	laser supply voltage
CFIL	3	external lter capacitor
MON	4	laser monitor diode input
DIN	5	central diode input
GND	6	ground
PWRON	7	power-on select input
CMFB	8	common mode feedback voltage input
RFFB	9	external RF feedback resistor
RFEQO	10	RF ampli er output
CDRW	11	gain select input for CD-A/V, CD-R/W
EQSEL	12	equalizer/speed select input (n=1,2or 4)
VDD	13	supply voltage
RGADJ	14	external laser supply gain adjust resistor

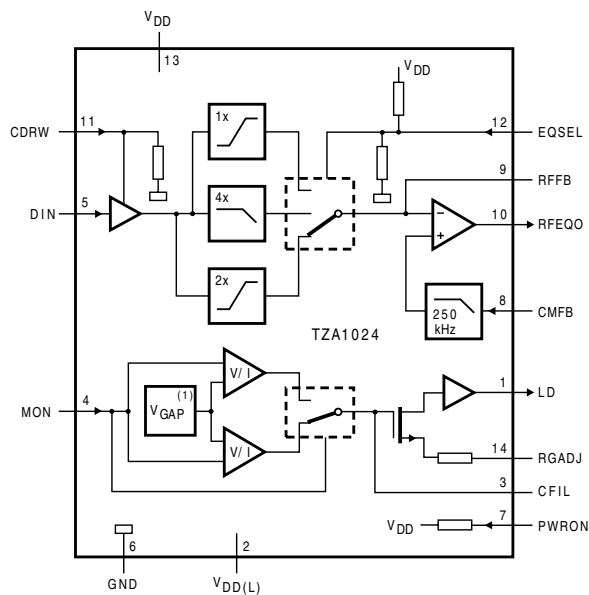

### Q103/Q104/Q105 : TDA7073AT

Pin Description

SYMBOL	PIN	DESCRIPTION
IN1-	1	negative input1
IN1+	2	positive input1
n.c.	3	not connected
n.c.	4	not connected
VP	5	positive supply voltage
IN2+	6	positive input2
IN2-	7	negative input2
n.c.	8	not connected
OUT2+	9	positive output 2
GND2	10	ground2
n.c.	11	not connected
OUT2-	12	negative output2
OUT1-	13	negative output1
GND1	14	ground1
n.c.	15	not connected
OUT1+	16	positive output 1

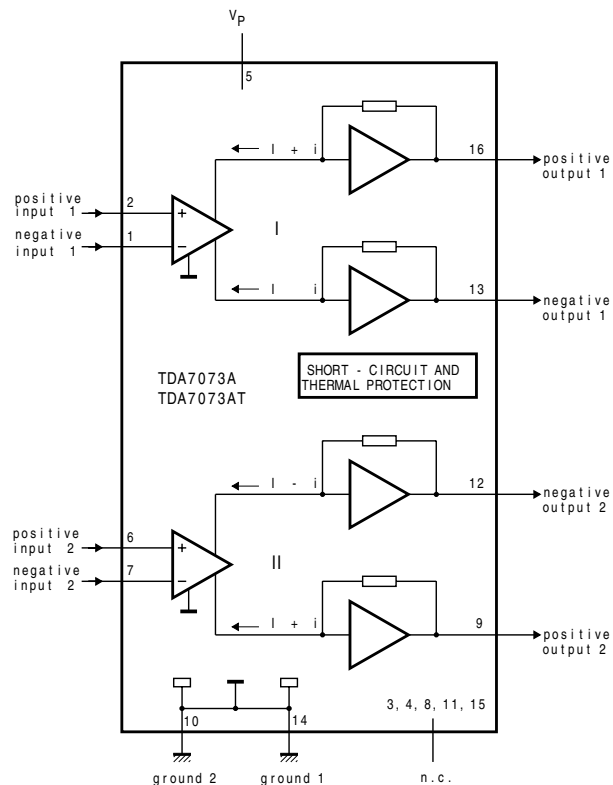

## Pin Description

SYMBOL	PIN	DESCRIPTION
HFREF	1	comparator common mode input
HFIN	2	comparator signal input
ISLICE	3	current feedback output from data slicer
V <sub>SSA1</sub>	4 <sup>(1)</sup>	analog ground 1
V <sub>DDA1</sub>	5 <sup>(1)</sup>	analog supply voltage 1
I <sub>ref</sub>	6	reference current output pin
V <sub>RIN</sub>	7	reference voltage for servo ADC's
D1	8	unipolar current input (central diode signal input)
D2	9	unipolar current input (central diode signal input)
D3	10	unipolar current input (central diode signal input)
D4	11	unipolar current input (central diode signal input)
R1	12	unipolar current input (satellite diode signal input)
R2	13	unipolar current input (satellite diode signal input)
V <sub>SSA2</sub>	14 <sup>(1)</sup>	analog ground 2
CROUT	15	crystal/resonator output
CRIN	16	crystal/resonator input
V <sub>DDA2</sub>	17 <sup>(1)</sup>	analog supply voltage 2
LN	18	DAC left channel differential output - negative
LP	19	DAC left channel differential output - positive
V <sub>neg</sub>	20 <sup>(1)</sup>	DAC negative reference supply (equivalent to DAC V <sub>SS</sub> )
V <sub>pos</sub>	21 <sup>(1)</sup>	DAC positive reference supply (equivalent to DAC V <sub>DD</sub> )
RN	22	DAC right channel differential output - negative
RP	23	DAC right channel differential output - positive
SELPLL	24	selects whether internal clock multiplier PLL is used
TEST1	25	test control input 1; this pin should be tied LOW
CL16	26	16.9344 MHz system clock output
DATA	27	serial data output (3-state)
WCLK	28	word clock output (3-state)
SCLK	29	serial bit clock output (3-state)
EF	30	C2 error flag output (3-state)
TEST2	31	test control input 2; this pin should be tied LOW
KILL	32	kill output (programmable; open-drain)
V <sub>SSD1</sub>	33 <sup>(1)</sup>	digital ground 2
V2/V3	34	versatile I/O: input versatile pin 2 or output versatile pin 3 (open-drain)
WCLI	35	word clock input (for data loopback to DAC)
SDI	36	serial data input (for data loopback to DAC)
SCLI	37	serial bit clock input (for data loopback to DAC)
$\overline{\text{RESET}}$	38	power-on reset input (active LOW)
SDA	39	microcontroller interface data I/O line (open-drain output)
SCL	40	microcontroller interface clock line input
RAB	41	microcontroller interface R/W and load control line input (4-wire bus mode)
SILD	42	microcontroller interface $\overline{\text{R/W}}$ and load control line input (4-wire bus mode)
STATUS	43	servo interrupt request line/decoder status register output (open-drain)
TEST3	44	test control input 3; this pin should be tied LOW
RCK	45	subcode clock input
SUB	46	P-to-W subcode bits output (3-state)
SFSY	47	subcode frame sync output (3-state)
SBSY	48	subcode block sync output (3-state)
CL11/4	49	11.2896 MHz or 4.2336 MHz (for microcontroller) clock output
V <sub>SSD2</sub>	50 <sup>(1)</sup>	digital ground 3
DOBM	51	bi-phase mark output (externally buffered; 3-state)
V <sub>DD1(P)</sub>	52 <sup>(1)</sup>	digital supply voltage 2 for periphery
CFLG	53	correction flag output (open-drain)
RA	54	radial actuator output
FO	55	focus actuator output
SL	56	sledge control output
V <sub>DD2(C)</sub>	57 <sup>(1)</sup>	digital supply voltage 3 for core
V <sub>SSD3</sub>	58 <sup>(1)</sup>	digital ground 4
MOTO1	59	motor output 1; versatile (3-state)
MOTO2	60	motor output 2; versatile (3-state)
V4	61	versatile output pin 4
V5	62	versatile output pin 5
V1	63	versatile input pin 1
LDON	64	laser drive on output (open-drain)

**Note**

1. All supply pins must be connected to the same external power supply voltage



**Q151:BU2630FV**

**Pin descriptions**

Pin No.	Pin name	Name	Function	I/O circuit
16	XOUT	Crystal resonator	For reference frequency	TYPE A
1	XIN			
2	V <sub>SS</sub>			
3	RPD	Phase comparator output	This is LO if the locally divided value is higher than the reference frequency, HI if it is lower, and Z if it matches.	TYPE E
4	P-R	Output port	This is controlled by the input data.	TYPE D
5	RON			
6	F-R	VCO input	Local input for reception	TYPE F
7	CE	Chip enable clock signal serial data	When CE is HIGH, the DA synchronized to the rise of CK is read into the internal shift register, and is latched at the timing of the CE fall.	TYPE B
8	CK			
9	DA			
10	LD	Unlock output	This goes ON when the PLL is unlocked on the transmission side	TYPE D
11	F-T	VCO input	Local input for transmission	TYPE F
12	TON	Output port	This is controlled by the input data	TYPE D
13	P-T			
14	TPD	Phase comparator output	This is LO if the locally divided value is higher than the reference frequency, HI if it is lower, and Z if it matches.	TYPE E
15	V <sub>DD</sub>	Power supply	2.5~5.5V	

**Q251 : LC89170M**

Pin no.	Symbol	I/O	Function
1	EXCK	I/O	Subcode interface shift clock input and output
2	SBSO	I	Subcode interface data input
3	SCOR	I	Subcode interface block synchronization input
4	WFCK	I	Subcode interface frame synchronization input
5	MCK	I	Clock input (16.9344 MHz)
6	XMODE	I	System reset and low power mode
7	GND		Ground
8	TEST	I	Test pin (Must be connected to ground in normal operation.)
9	SW1	I	EXCK I/O setting (L: clock output, H: clock input)
10	SW2	I	EXCK clock output pulse width selection (L: double speed support, H: normal speed)
11	SCLK	I	Command interface shift clock input
12	SRDT	O	Command interface data output
13	DQSY	O	Command interface readout enable output
14	VDD		Power supply

**Block Diagram**

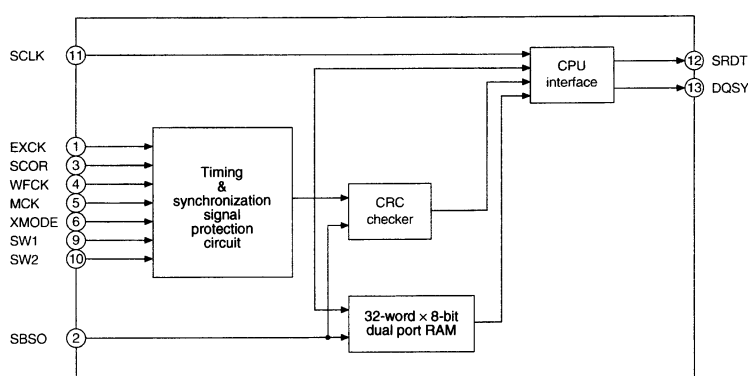

A06253

**Q708:TC9413AP**

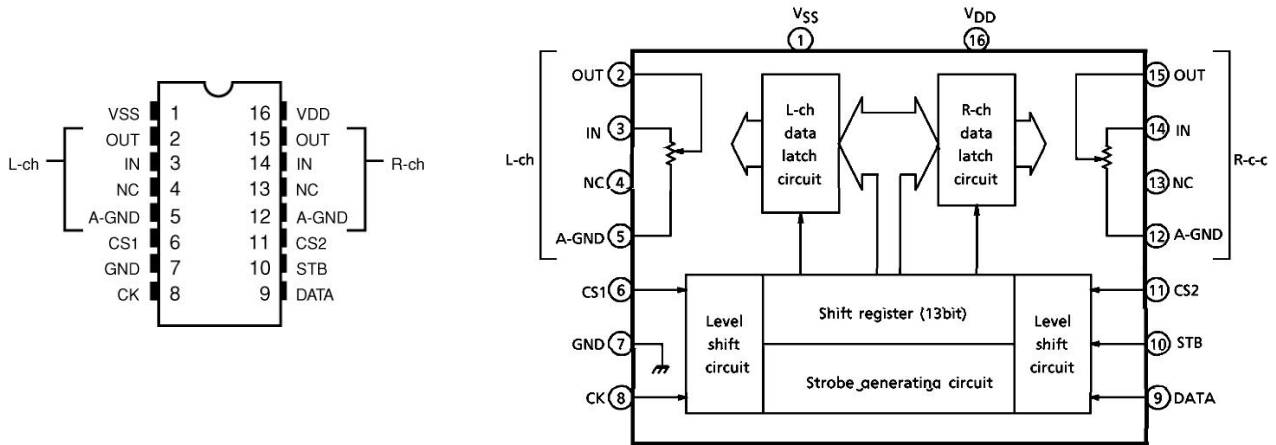

**PIN DESCRIPTION**

PIN No.	SYMBOL	PIN NAME	FUNCTION	REMARK
1	V <sub>SS</sub>	Negative power supply pin	When using two power supplies <ul style="list-style-type: none"> <li>— V<sub>DD</sub> = 6.0~17V</li> <li>— GND = 0V</li> <li>— V<sub>SS</sub> = -6.0~ -17V</li> </ul>	—
7	GND	Digital GND pin		
16	V <sub>DD</sub>	Positive power supply pin		
2	L-OUT	Volume output pin		—
15	R-OUT			
3	L-IN	Volume input pin		
14	R-IN			
5	L-A-GND	Analog GND pin		
12	R-A-GND			
6	CS1	Chip select input pin	Up to 4 chips on the same bus can be used by switching over chip select code.	—
11	CS2			
8	CK	Clock input pin	Data transfer clock input	Low threshold value input pin
9	DATA	Data input pin	Volume setup serial data input	
10	STB	Strobe input pin	Data write strobe input	
4, 13	NC	No connection		—

**Q810: MC44603**

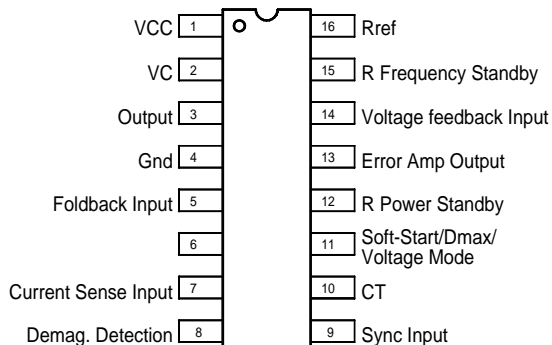

CL 96532076\_030.eps  
290799

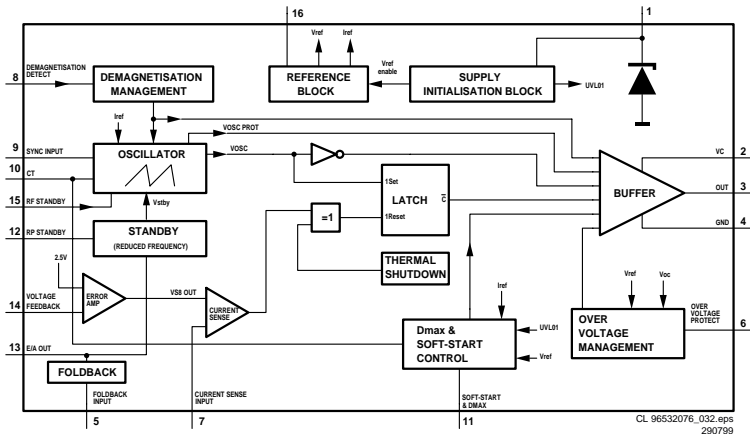

CL 96532076\_032.eps  
290799

Pin	Name	Description
1	VCC	This pin is the positive supply of the IC. The operating voltage range after start-up is 9.0 to 14.5 V.
2	VC	The output high state (VOH) is set by the voltage applied to this pin.
3	Output	peak currents up to 750 mA can be sourced or sunk, suitable for driving either MOSFET or bipolar transistors.
4	Gnd	The groundpin is a single return, typically connected back to the power source.
5	Foldback Input	The foldback function provides overload protection.
6	Oversvoltage Protection	When the oversvoltage protection pin receives a voltage greater than 2.5V, the device is disabled and requires a complete restart sequence.
7	Current Sense Input	A voltage proportional to the current flowing into the power switch is connected to this input.
8	Demagnetisation Detection	A voltage delivered by an auxiliary transformer winding provides to the demagnetisation pin an indication of the magnetisation state of the flyback transformer. A zero voltage detection corresponds to complete core saturation.
9	Synchronisation Input	The synchronisation input pin can be activated with either a negative pulse going from a level between 0.7V and 3.7V to Gnd or a positive pulse going from a level between 0.7V and 3.7V up to a level higher than 3.7V. The oscillator runs free when Pin 9 is connected to Gnd.
10	C <sub>T</sub>	The normal mode oscillator frequency is programmed by the capacitor CT choice together with the Rref resistance value. CT, connected between Pin 10 and Gnd, generates the oscillator sawtooth.
11	Soft-Start/Dmax/Voltage Mode	A capacitor, resistor or a voltage source connected to this pin limits the switching duty-cycle. This pin can be used as a voltage mode control input. By connecting Pin 11 to Ground, the MC44603 can be shut down.
12	RP Standby	A voltage level applied to the RP Standby pin determines the output power level at which the oscillator will turn into the reduced frequency mode of operation (i.e. standby mode). An internal hysteresis comparator allows to return in the normal mode at a higher output power level.
13	E/A Out	The error amplifier output is made available for loop compensation.
14	Voltage Feedback	This is the inverting input of the Error Amplifier. It can be connected to the switching power supply output through an optical (or other) feedback loop.
15	RF Standby	The reduced frequency or standby frequency programming is made by the RF Standby resistance choice.
16	Rref	Rref sets the internal reference current. The internal reference current ranges from 100µA to 500µA. This requires that 5.0k < Rref < 25k .

**QM01:STA016**

Pin Description

PIN	Pin Name	Type	Description	Source/Dest
<b>CDDSP interface</b>				
1	CD_LRCK	I	DSP Interface left/right Clock	From DSP
3	CD_SDI	I	DSP interface serial data	From DSP
2	CD_BCK	I	DSP interface bit clock	From DSP
<b>SDI interface</b>				
9	BS_SDI	I	Bitstream interface serial data	From MCU
7	BS_LRCK	I	Bitstream interface left/right Clock	From MCU
8	BS_BCK	I	Bitstream interface clock	From MCU
4	DREQ	O	Bitstream data request	To MCU
<b>PCM IN interface</b>				
13	BCKI	I	ADC bit clock	From ADC
14	SDI	I	ADC serial data	From ADC
12	LRCKI	I	ADC left/right Clock	From ADC
<b>PCM OUT interface</b>				
20	LRCKO	O	DAC Interface left/right Clock	To DAC
22	SDO	O	DAC serial data	To DAC
21	BCKO	O	DAC bit clock	To DAC
19	OSCK	O	DAC oversampling clock	To DAC/ADC
<b>GPSO interface</b>				
55	GPSO_CK	I	GPSO bit clock	From MCU
54	GPSO_SDO	O	GPSO serial data	To MCU
56	GPSO_REQ	O	GPSO request signal	To MCU
<b>GPIO interface</b>				
26	IODATA0	I/O	GPIO DATA0	
27	IODATA1	I/O	GPIO DATA1	
28	IODATA2	I/O	GPIO DATA2	
31	IODATA3	I/O	GPIO DATA3	
32	IODATA4	I/O	GPIO DATA4	
33	IODATA5	I/O	GPIO DATA5	
34	IODATA6	I/O	GPIO DATA6	
35	IODATA7	I/O	GPIO DATA7	
44	IODATA8	I/O	GPIO DATA8	
45	IODATA9	I/O	GPIO DATA9	
46	IODATA10	I/O	GPIO DATA10	
47	IODATA11	I/O	GPIO DATA11	
48	IODATA12	I/O	GPIO DATA12	
49	IODATA13	I/O	GPIO DATA13	
50	IODATA14	I/O	GPIO DATA14	
51	IODATA15	I/O	GPIO DATA15	

QM01:STA016

PIN	Pin Name	Type	Description	Sourde/Dest
<b>HANDSHAKE SIGNALS</b>				
60	STB	I	Strobe signal	From MCU
59	RQST	O	I2C data signal	To MCU
<b>I<sup>2</sup>C LINK</b>				
63	SCL	I	I2C clock signal	From MCU
64	SDA	I/O	I2C data signal	To MCU
<b>MISCELLANEOUS</b>				
17	XTI	I	Oscillator input	
18	XTO	O	Oscillator output	
25	CLKOUT	O	Buffered output clock	
15	-RESET	I	Reset	
16	-TESTEN	I	Reserved for test purpose	
40	FILT0	I	PLL external filter	
38	FILT1		PLL external filter	
<b>POWER SUPPLY</b>				
39	PLL_VCC			
41	PLL_GND			
5	VDD_1		Digital supply (2.5V Power Supply)	
10	VDD_2		Digital supply (2.5V Power Supply)	
29	VDD_3		Digital supply (2.5V Power Supply)	
36	VDD_4		Digital supply (2.5V Power Supply)	
53	VDD_5		Digital supply (2.5V Power Supply)	
62	VDD_6		Digital supply (2.5V Power Supply)	
23	VCC_1		Digital supply (3.3V Power Supply)	
42	VCC_2		Digital supply (3.3V Power Supply)	
58	VCC_3		Digital supply (3.3V Power Supply)	
6	VSS_1			
11	VSS_2			
24	VSS_3			
30	VSS_4			
37	VSS_5			
43	VSS_6			
52	VSS_7			
57	VSS_8			
61	VSS_9			

Pin Assignment

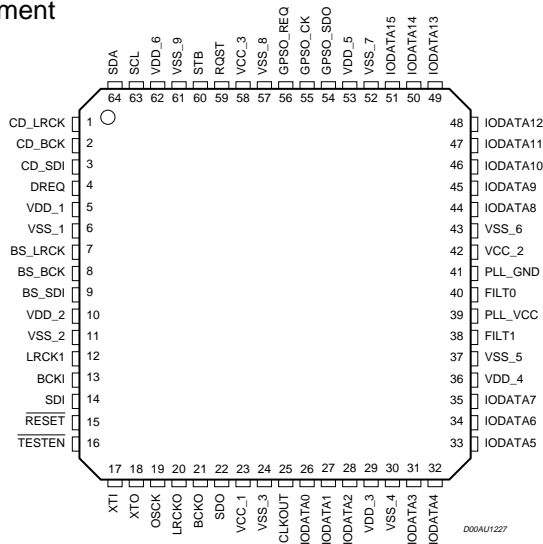

**QR01:HIN202ECB**

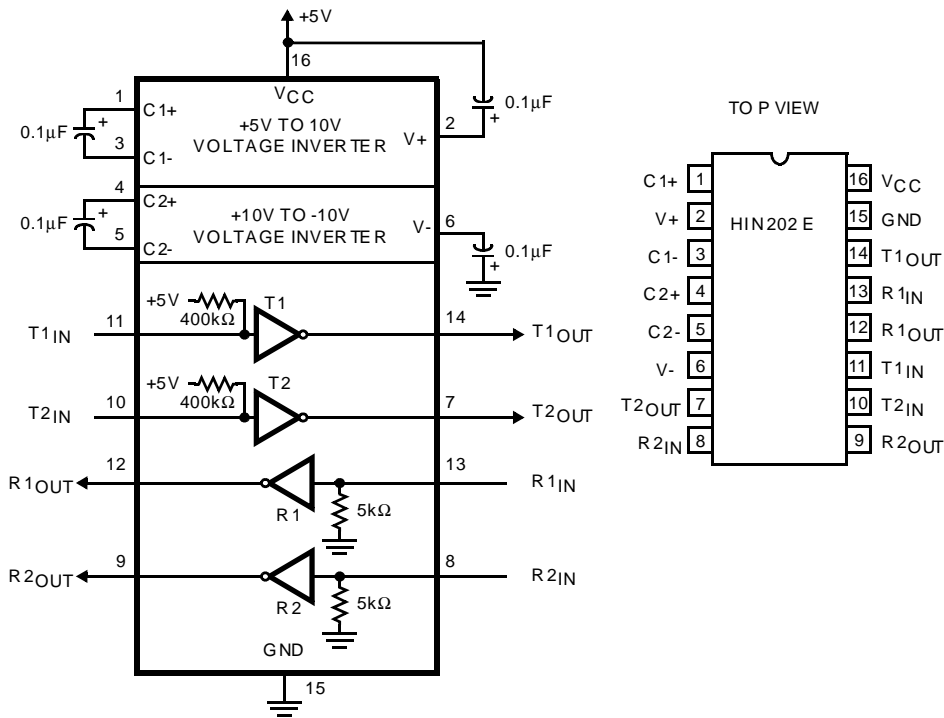

**Pin Descriptions**

PIN	FUNCTION
V <sub>CC</sub>	Power Supply Input 5V ±10%.
V+	Internally generated positive supply (+10V nominal).
V-	Internally generated negative supply (-10V nominal).
GND	Ground Lead. Connect to 0V.
C1+	External capacitor (+ terminal) is connected to this lead.
C1-	External capacitor (- terminal) is connected to this lead.
C2+	External capacitor (+ terminal) is connected to this lead.
C2-	External capacitor (- terminal) is connected to this lead.
T <sub>IN</sub>	Transmitter Inputs. These leads accept TTL/CMOS levels. An internal 400kΩ pull-up resistor to V <sub>CC</sub> is connected to each lead.
T <sub>OUT</sub>	Transmitter Outputs. These are RS-232 levels (nominally ±10V).
R <sub>IN</sub>	Receiver Inputs. These inputs accept RS-232 input levels. An internal 5kΩ pull-down resistor to GND is connected to each input
R <sub>OUT</sub>	Receiver Outputs. These are TTL/CMOS levels.
EN, EN	Receiver Enable Input. With EN = 5V (HIN213E EN=0V), the receiver outputs are placed in a high impedance state.
SD, SD	Shutdown Input. With SD = 5V (HIN213E SD = 0V), the charge pump is disabled, the receiver outputs are in a high impedance state (except R4 and R5 of HIN213E) and the transmitters are shut off.
NC	No Connect. No connections are made to these leads.

**QU01: MB90F574A**

Pin Description

Pin	PORT	PIN NEME	I/O	DESCRIPTION	
1	P31/RD	LOAD_SW	I	Find Open/Close of CD Tray	Active Low
2	P32/WRL	TRAY_CONT1	O	Control Signal to CD Tray	H   Close   L   Open
3	P33/WRH	TRAY_CONT2	O	Control Signal to CD Tray	L   H
4	P34/HRQ	MOT_SW	O	Turn CD Spindle	Active High
5	P35/HAK	MP3_SEL	O	In put Signal Change to MP3	MP3 : High
6	P36/RDY	FUN	O	Recording of CDR, Turn Fun	FUN ON : High
7	P37/CLK	DAC_RES	O	Reset DAC	RESET : Low
8	VCC	+5V			
9	P40/SIN0	TTXD	I	Connected to Flash Writer	
10	P41/SOT0	TRXD	O	Connected to Flash Writer	
11	P42/SCK0	TCK	I	Connected to Flash Writer	
12	P43/SIN1	RXD	I	RS232C	
13	P44/SOT1	TXD	O	RS232C	
14	P45/SCK1	RTS	O	RS232C	
15	P46/PPG0	CTS	I	RS232C	
16	P47/PPG1	N.C	I		
17	P50/SIN2	CDR_SDAI	I	Serial Data from CDR	LSB First
18	P51/SOT2	CDR_SDAO	O	Serial Data to CDR	LSB First
19	P52/SCK2	CDR_SCL	I	Serial Clock Input from CDR	Typ. 100KHz
20	P53/SIN3	TXT_SDA	I	Serial Data from CD-TEXT Decoder(LC89170M)	LSB First
21	P54/SOT3	N.C	I		
22	P55/SCK3	TXT_SCL	O	Serial Clock to CD-TEXT Decoder(LC89170M)	Max 5MHz
23	P56/IN0	N.C	I		Active Low
24	P57/IN1	N.C	I		
25	P60/SIN4	CD_SDAI	I	Serial Data Input from CD10	
26	P61/SOT4	CD_SDAO	I/O	Serial Data to CD10 and BU2630FV	
27	P62/SCK4	CD_SCL	O	Serial Clock to CD10 and BU2630FV	Max ≒ 700KHz
28	P63/CKOT	CD_RST	O	Reset Signal to CD10	Active Low
29	P64/OUT0	EE_SDA	I/O	Serial Data to AT24C04/STA016T	
30	P65/OUT1	EE_SCL	O	Serial Data to AT24C04/STA016T	
31	P66/OUT2	MP_RST	O	Reset Signal to STA016T	Active Low
32	P67/OUT3	MP_STB	O	Strobe Signal to STA016T	Active Low
33	VSS	GNDD			
34	C	C			
35	P70	CD_RAB	O	Latch Signal to CD10 Decoder Part	Active High
36	P71	CD_SILD	O	Latch Signal to CD10 Servo Part	Active ↓
37	P72	PLL_CS	O	Latch Signal to BU2630FV	Active ↑
38	DVCC	+5V			
39	DVSS	GNDD			
40	P73/DA0	N.C	I		
41	P74/DA1	N.C	I		
42	AVCC	+5VA			
43	AVRH	+5VA			
44	AVRL	GND			
45	AVSS	GND			
46	P80/AN0	N.C	I		
47	P81/AN1	N.C	I		
48	P82/AN2	N.C	I		
49	P83/AN3	N.C	I		
50	P84/AN4	N.C	I		
51	P85/AN5	N.C	I		
52	P86/AN6	N.C	I		
53	P87/AN7	N.C	I		
54	VCC	+5V			
55	P90/CS0	VOL_SDA	O	Serial Data to TC9412	LSB First
56	P91/CS1	VOL_SCL	O	Serial Clock to TC9412	Active ↑
57	P92/CS2	VOL_CS	O	Latch Signal to TC9412	Active ↑
58	P93/CS3	HP_SEL	O	Head Phone Out Put Source Select	Low : CDR
59	P94/CS4	LINE_SEL	O	CD/CDR(Analog, Digital Out PutSource Select	Low : CDR

Pin Description

60	P95/CS5	HP_MUTE	O	Connected to Head phone Out Put Mute	Active High
61	P96/CS6	CDR_MUTE	O	Connected to CDR Out Put(Analog)Mute	Active High
62	P97/C57	CD_MUTE	O	Connected to CD Out Put(Analog)Mute	Active High
63	VSS	GNDD			
64	PA0/AIN0/IRQ6	CD_DMUTE	O	Connected to CD Out Put(Digital)Mute	Active low
65	PA1/BIN0	MP3_LED	O	Inserted MP3 Disc LED lighting	Active low
66	PA2/ZIN0	PITCH_LED	O	Pitch Control on LED lighting	Active low
67	PA3/AIN1/IRQ7	N.C	I		
68	PA4/BIN1	N.C	I		
69	PA5/ZIN1	DIS_RSTN	O	Reset Signal to uP	Active Low
70	PA6/SDA	FL_SDA	I/O	Serial Data with DISPLAY uP	
71	PA7/SCL	FL_SCL	O	Serial Clock to DISPLAY uP	
72	PB0/IRQ0	CDR_RREQ	I	Interrupt Request Signal from CDR	Active ↓
73	X1A	N.C			
74	X0A	N.C			
75	PB1/IRQ1	TXT_REQ	I	Interrupt Request Signal for Read fromCD-TEXT Decoder(LC89170M)	Active ↓
76	PB2/IRQ2	HFD	I	HF find Signal from CD HF Detector	Active Low
77	PB3/IRQ3	MP_RQST	I	Communication Request Signal fromSTA016T	Active Low
78	PB4/IRQ4	N.C	I		
79	PB5/IRQ5	N.C	I		
80	PB6/ADTG	N.C	I		
81	PB7	N.C	I		
82	PC0	CDR_RSTN	O	Reset Signal to CDR	Active Low
83	PC1	CDR_SREQN	O	Command Request Signal to CDR	Active Low
84	PC2	CDR_SRDYN	O	1 Byte Latch Signal to TC9412CDR 1Byte	Active Low
85	PC3	N.C	I		
86	HST	---			
87	MD2	TMODE			
88	MD1	---			
89	MD0	TAUX3			
90	RST	RESET			
91	VSS	GNDD			
92	X0	8MHz X'tal			
93	X1	8MHz X'tal			
94	VCC	+5V			
95	P00/AD00	TAUX		Connected to Flash Writer	
96	P01/AD01	N.C	I		
97	P02/AD02	N.C	I		
98	P03/AD03	N.C	I		
99	P04/AD04	N.C	I		
100	P05/AD05	N.C	I		
101	P06/AD06	N.C	I		
102	P07/AD07	N.C	I		
103	P10/AD08	N.C	I		
104	P11/AD09	N.C	I		
105	P12/AD10	N.C	I		
106	P13/AD11	N.C	I		
107	P14/AD12	N.C	I		
108	P15/AD13	N.C	I		
109	P16/AD14	N.C	I		
110	P17/AD15	N.C	I		
111	P20/A16	N.C	I		
112	P21/A17	N.C	I		
113	P22/A18	N.C	I		
114	P23/A19	N.C	I		
115	P24/A20	N.C	I		
116	P25/A21	N.C	I		
117	P26/A22	N.C	I		
118	P27/A23	N.C	I		
119	VSS	GNDD			
120	P30/ALE	N.C	I		

### 13. EXPLODED VIEW AND PARTS LIST

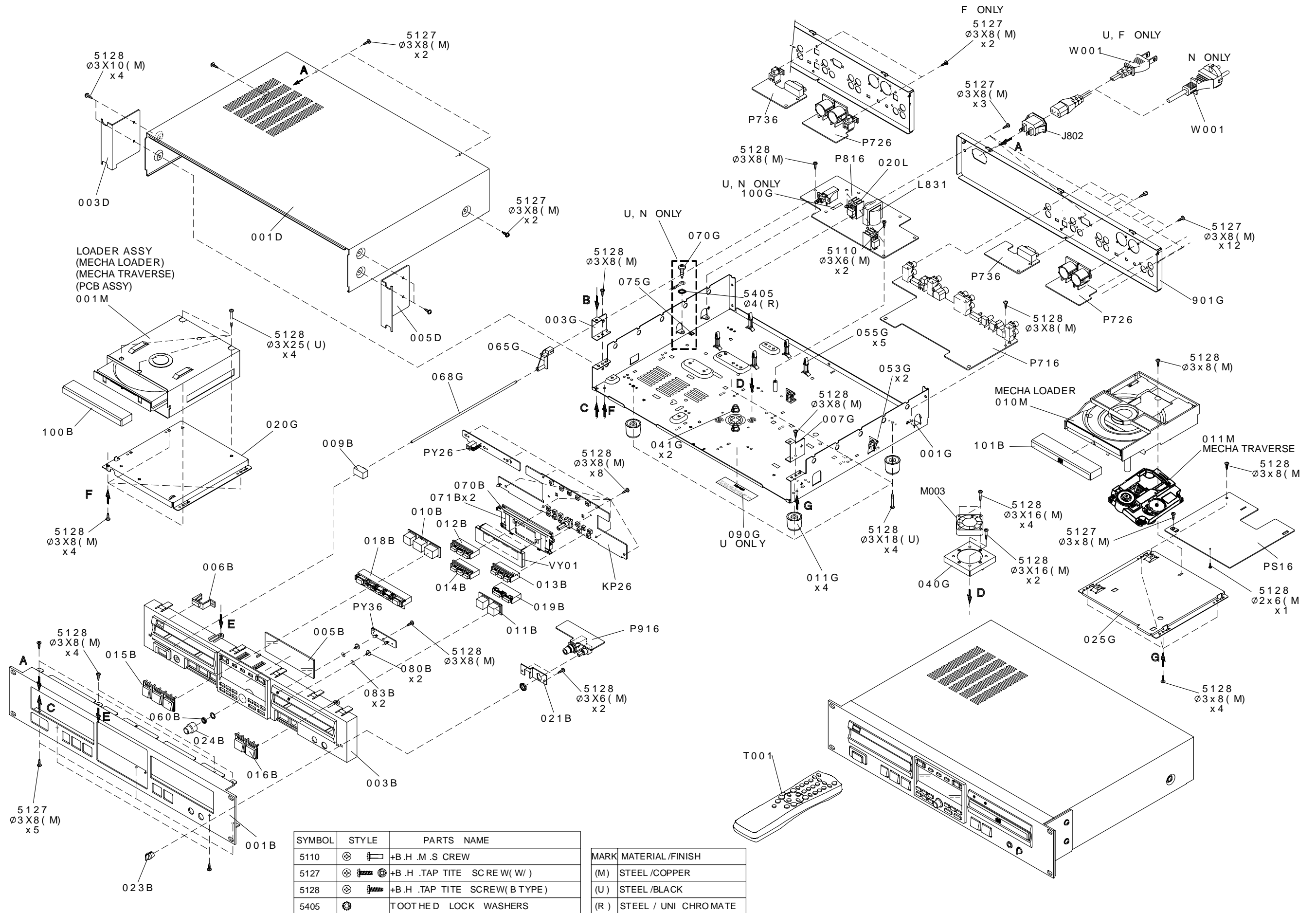



POS. NO	VERS. COLOR	PART NO. (FOR EUR)	DESCRIPTION	PART NO. (MJI)
001B		12AK248010	FRONT PANEL BLACK	12AK248010
003B		388K105026	FRONT CHASSIS BLACK	388K105026
005B		388K158010	WINDOW	388K158010
006B		387K355010	LENS	387K355010
009B		12AK270010	BUTTON POWER	12AK270010
010B		388K270010	BUTTON RUBBER 3KEY	388K270010
011B		388K270110	BUTTON RUBBER 2KEY	388K270110
012B		388K270020	BUTTON ERASE BL	388K270020
013B		388K270220	BUTTON TIME BL	388K270220
014B		388K270030	BUTTON FINAL BL	388K270030
015B		388K270350	BUTTON REC PLAY PAUSE	388K270350
016B		388K270360	BUTTON PLAY PAUSE	388K270360
018B		388K270080	BUTTON OPEN CLOSE BL	388K270080
019B		388K270050	BUTTON FF REW BL	388K270050
023B		284T154310	KNOB PHONE VOLUME BL	284T154310
024B		388K154010	KNOB FOR JOG BL	388K154010
080B		230K355030	LENS MP2 AND PITCH	230K355030
100B		416K053150	COVER CDR BL	416K053150
101B		12AK063010	ESCUTCHEON CD BL	12AK063010
003D		371K160040	MOUNT BRACKET L	371K160040
005D		371K160050	MOUNT BRACKET R	371K160050
011G		229K057010	LEG	229K057010
065G		12AK121010	LINK FOR POWER SWITCH	12AK121010
001M		ZK416K0020	UNIT KIT LOADER ASSY CRD-RA2A AUDIO UNIT CEC	ZK416K0020
010M		05AK304500	MECHA LOADER ASSY CD VAL2212 08	05AK304500
011M		05AK304510	MECHA TRAVERSE UNIT CD VAM2202 08	05AK304510
▲ J802	/F	nsp	JACK 2P MAINS INLET PW1910-H	YJ04002440
▲ J802	/N/U	YJ04002450	JACK 3P MAINS INLET M1910-D	YJ04002450
M003		MM01200290	DC BRUSHLESS FAN KD1204PFB2-8	MM01200290
WD02		nsp	JUMPER LEAD FPC J731- LOADER ASSY	YU17200520
WD03		nsp	JUMPER LEAD FPC J631-JU02	YU15080520
WD04		nsp	JUMPER LEAD FPC JU01- LOADER ASSY	YU09150520
			<b>PACKING</b>	
001T	/F	nsp	USER GUIDE(F)	12AK851110
001T	/N/U	12AK851250	USER GUIDE(U,N)	12AK851250
005T	/N/U	12AK851010	CD-ROM FOR USER GUIDE 7 LANGUAGES	12AK851010
T001		ZK399K0010	REMOTE CONTROLLER RC2100DR	ZK399K0010
▲ W001	/F	nsp	MAINS CORD 2P FOR 12A 124V AC	ZC01801050
▲ W001	/N	ZC02003190	MAINS CORD 3P FOR N 10A 249V AC	ZC02003190
▲ W001	/U	nsp	MAINS CORD 3P 10A 124V NM U KAW	ZC02002180
			<b>NOT STANDARD SPARE PARTS</b>	
001D		nsp	LID TOP COVER BL	292J257050
001S		nsp	PACKING CASE	12AK801010
003S		nsp	CUSHION	12AK809010

NOTE : "nsp" PART IS LISTED FOR REFERENCE ONLY, MARANTZ WILL NOT SUPPLY THESE PARTS.

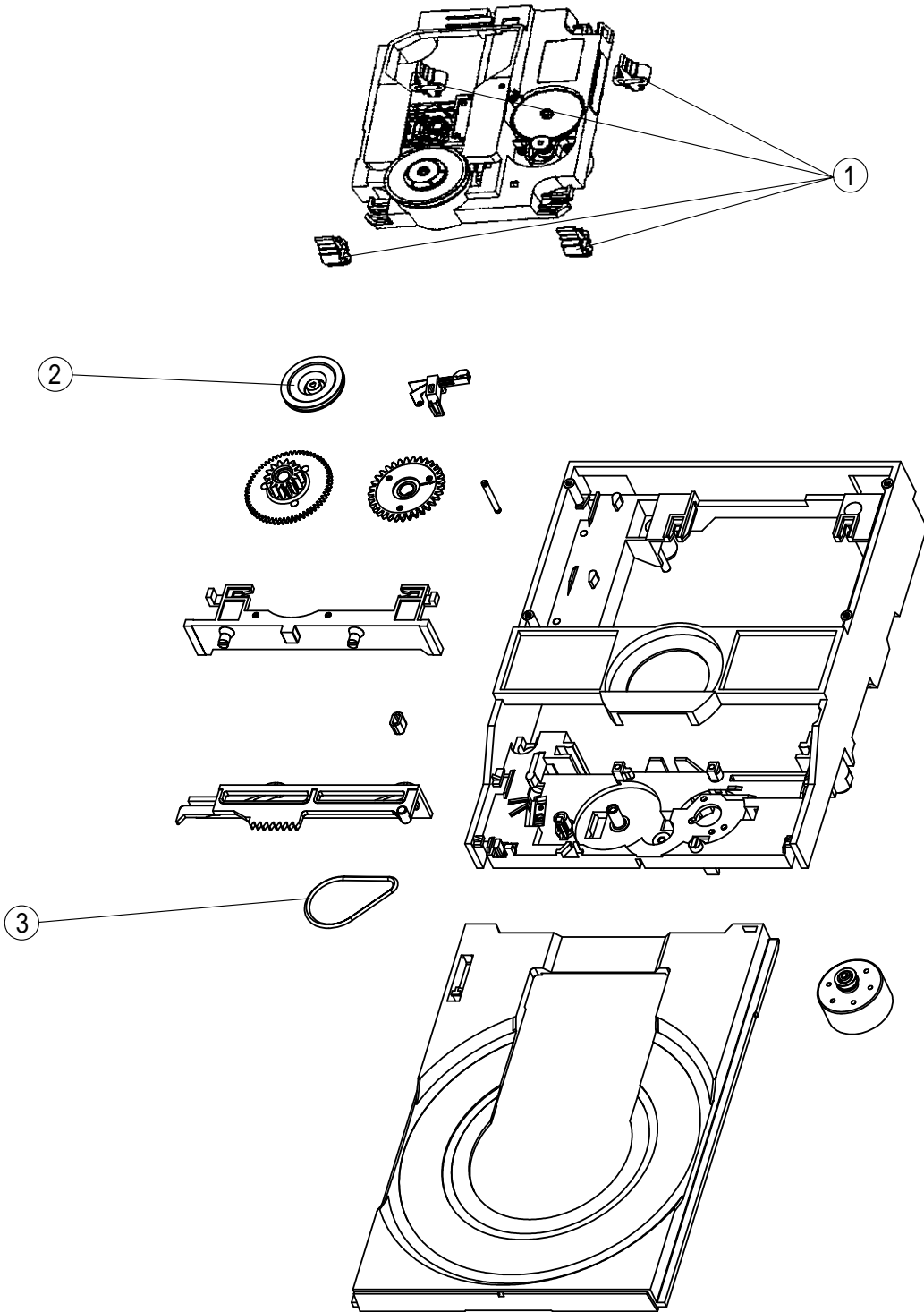

POS. NO	VERS. COLOR	PART NO. (FOR EUR)	DESCRIPTION	PART NO. (MJI)
1		QP40410986	SUSPENSION(4822 404 10986)	QP40410986
2		QP40111709	CLAMPER(4822 401 11709)	QP40111709
3		QP35810266	BELT(4822 358 10266)	QP35810266

NOTE : "nsp" PART IS LISTED FOR REFERENCE ONLY, MARANTZ WILL NOT SUPPLY THESE PARTS.

# 14. ELECTRICAL PARTS LIST

## ASSIGNMENT OF COMMON PARTS CODES.

### RESISTORS

R\*\*\*: 1) GD05xxx140, Carbon film fixed resistor, ±5% 1/4W  
 R\*\*\*: 2) GD05xxx160, Carbon film fixed resistor, ±5% 1/6W

① — Resistance value

Examples ;

① Resistance value  
 0.1 Ω .... 001    10 Ω .... 100    1 kΩ .... 102    100 kΩ .... 104  
 0.5 Ω .... 005    18 Ω .... 180    2.7 kΩ .... 272    680 kΩ .... 684  
 1 Ω .... 010    100 Ω .... 101    10 kΩ .... 103    1 MΩ .... 105  
 6.8 Ω .... 068    390 Ω .... 391    22 kΩ .... 223    4.7 MΩ .... 475

Note : Please distinguish 1/4W from 1/6W by the shape of parts used actually.

### CAPACITORS

C\*\*\*: CERAMIC CAP.

3) DD1xxx370, Ceramic capacitor  
 Disc type  
 Temp.coeff.P350 ~N1000, 50V  
 ② Capacity value  
 ③ Tolerance

Examples ;

② Tolerance (Capacity deviation)  
 ±0.25 pF .... 0  
 ±0.5 pF .... 1  
 ±5% .... 5

\* Tolerance of COMMON PARTS handled here are as follows :

0.5 pF ~ 5 pF .... ±0.25 pF  
 6 pF ~ 10 pF .... ±0.5 pF  
 12 pF ~ 560 pF .... ±5%

③ Capacity value

0.5 pF .... 005    3 pF .... 030    100 pF .... 101  
 1 pF .... 010    10 pF .... 100    220 pF .... 221  
 1.5 pF .... 015    47 pF .... 470    560 pF .... 561

C\*\*\*: CERAMIC CAP.

4) DK16xxx300, High dielectric constant ceramic capacitor  
 Disc type  
 Temp.chara. 2B4, 50V  
 ④ Capacity value

Examples ;

④ Capacity value  
 100 pF .... 101    1000 pF .... 102    10000 pF .... 103  
 470 pF .... 471    2200 pF .... 222

C\*\*\*: 5) ELECTROLY CAP. (  $\text{⏏}$  ), 6) FILM CAP. (  $\text{⏏}$  )

5) EAxxx10, Electrolytic capacitor  
 One-way lead type, Tolerance ±20%  
 ⑤ Capacity value  
 ⑥ Working voltage

Examples ;

⑤ Capacity value  
 0.1 μF .... 104    4.7 μF .... 475    100 μF .... 107  
 0.33 μF .... 334    10 μF .... 106    330 μF .... 337  
 1 μF .... 105    22 μF .... 226    1100 μF .... 118  
 2200 μF .... 228

⑥ Working voltage

6.3V .... 006    25V .... 025  
 10V .... 010    35V .... 035  
 16V .... 016    50V .... 050

6) DF15xxx350 Plastic film capacitor  
 DF15xxx310 One-way type, Mylar ±5% 50V  
 DF16xxx310 Plastic film capacitor  
 One-way type, Mylar ±10% 50V  
 ⑦ Capacity value

Examples ;

⑦ Capacity value  
 0.001 μF (1000 pF) ..... 102    0.1 μF .... 104  
 0.0018 μF ..... 182    0.56 μF .... 564  
 0.01 μF ..... 103    1 μF .... 105  
 0.015 μF ..... 153

NOTE : 1) The above CODES ( R\*\*\*, R\*\*\*, C\*\*\*, C\*\*\* and C\*\*\* ) are omitted on the schematic diagram in some case.

2) On the occasion, be confirmed the common parts on the parts list.

3) Refer to "Common Parts List" for the other common parts (R105, DD4, DK4).

## NOTE ON SAFETY FOR FUSIBLE RESISTOR :

The suppliers and their type numbers of fusible resistors are as follows;

1. KOA Corporation

Part No. (MJI)	Type No. (KOA)	Description
NH05xxx140	RF25SxxxΩJ	(±5% 1/4W)
NH05xxx120	RF50SxxxΩJ	(±5% 1/2W)
NH85xxx110	RF73B2AxxxΩJ	(±5% 1/10W)
NH95xxx140	RF73B2ExxxΩJ	(±5% 1/4W)

\* Resistance value    Resistance value (0.1 Ω – 10 kΩ)

2. Matsushita Electronic Components Co., Ltd

Part No. (MJI)	Type No. (MEC)	Description
NF05xxx140	ERD-2FCJxxx	(±5% 1/4W)
RF05xxx140		
NF02xxx140	ERD-2FCGxxx	(±2% 1/4W)
RF02xxx140		

\* Resistance value    \* Resistance value

Examples ;

\* Resistance value  
 0.1 Ω .... 001    10 Ω .... 100    1 kΩ .... 102    100 kΩ .... 104  
 0.5 Ω .... 005    18 Ω .... 180    2.7 kΩ .... 272    680 kΩ .... 684  
 1 Ω .... 010    100 Ω .... 101    10 kΩ .... 103    1 MΩ .... 105  
 6.8 Ω .... 068    390 Ω .... 391    22 kΩ .... 223    4.7 MΩ .... 475

## ABBREVIATION AND MARKS

ANT. : ANTENNA	BATT. : BATTERY
CAP. : CAPACITOR	CER. : CERAMIC
CONN. : CONNECTING	DIG. : DIGITAL
HP : HEADPHONE	MIC. : MICROPHONE
μ-PRO : MICROPROCESSOR	REC. : RECORDING
RES. : RESISTOR	SPK : SPEAKER
SW : SWITCH	TRANSF. : TRANSFORMER
TRIM. : TRIMMING	TRS. : TRANSISTOR
VAR. : VARIABLE	X'TAL : CRYSTAL

## NOTE ON FUSE :

Regarding to all parts of parts code **FS20xxx2xx**, replace only with Wickmann-Werke GmbH, Type 372 non glass type fuse.

## NOTE ON SAFETY :

Symbol  $\text{⚠}$  Fire or electrical shock hazard. Only original parts should be used to replaced any part marked with symbol  $\text{⚠}$ . Any other component substitution (other than original type), may increase risk of fire or electrical shock hazard.

## 安全上の注意 :

$\text{⚠}$  がついている部品は、安全上重要な部品です。必ず指定されている部品番号の部品を使用して下さい。

POS. NO	VERS. COLOR	PART NO. (FOR EUR)	DESCRIPTION	PART NO. (MJI)	POS. NO	VERS. COLOR	PART NO. (FOR EUR)	DESCRIPTION	PART NO. (MJI)
			<b>P716-ANALOG IN/OUT DIGITAL IN/OUT CIRCUIT BOARD</b>						
			<b>P716-CAPACITORS</b>						
C301		nsp	CER. CHIP 47pF ±5% CG 50V	DD95470300	C662		nsp	ELECT. 220µF M 16V RA-2	OA22701620
C302		nsp	CER. CHIP C1608X7R1H104K	DK96104300	C663				
C303		nsp	CER. CHIP C1608X7R1H104K	DK96104300	}				
C304		nsp	CER. CHIP 22pF ±5% CG 50V	DD95220300	C667		nsp	ELECT. 47µF M 25V RA-2	OA47602520
C305		nsp	CER. CHIP 22pF ±5% CG 50V	DD95220300	C668		nsp	ELECT. 47µF M 25V RA-2	OA47602520
C311		nsp	ELECT. 47µF M 25V RA-2	OA47602520	C669		DF15332350	FILM 0.0033µF J M 50V	DF15332350
C351		nsp	CER. CHIP 22pF ±5% CG 50V	DD95220300	C670		DF15332350	FILM 0.0033µF J M 50V	DF15332350
C352		nsp	CER. CHIP 100pF ±5% CG 50V	DD95101300	C671		nsp	ELECT. 47µF M 25V RA-2	OA47602520
C353		nsp	ELECT. 10µF M 50V RA-2	OA10605020	C672		nsp	ELECT. 47µF M 25V RA-2	OA47602520
C354		nsp	CER. CHIP 47pF ±5% CG 50V	DD95470300	C673		nsp	ELECT. 47µF M 25V RA-2	OA47602520
C355		nsp	CER. CHIP 2200pF	DK96222300	C674		nsp	ELECT. 47µF M 25V RA-2	OA47602520
C356		nsp	CER. CHIP C1608X7R1H104K	DK96104300	C675		DF15222350	FILM 0.0022µF J M 50V	DF15222350
C357		nsp	CER. CHIP 22pF ±5% CG 50V	DD95220300	C676		DF15222350	FILM 0.0022µF J M 50V	DF15222350
C361		nsp	CER. CHIP 22pF ±5% CG 50V	DD95220300	C677		nsp	CER. CHIP C1608X7R1H104K	DK96104300
C362		nsp	CER. CHIP C1608X7R1H104K	DK96104300	C678		nsp	ELECT. 47µF M 25V RA-2	OA47602520
C363		nsp	CER. CHIP C1608X7R1H104K	DK96104300	C679		nsp	CER. CHIP C1608X7R1H104K	DK96104300
C364		nsp	CER. CHIP 100pF ±5% CG 50V	DD95101300	C680		nsp	ELECT. 47µF M 25V RA-2	OA47602520
C365		nsp	ELECT. 10µF M 50V RA-2	OA10605020	C681		nsp	CER. CHIP C1608X7R1H104K	DK96104300
C366		nsp	CER. CHIP 47pF ±5% CG 50V	DD95470300	C682		nsp	CER. CHIP C1608X7R1H104K	DK96104300
C367		nsp	CER. CHIP 2200pF	DK96222300	C683		nsp	CER. CHIP 22pF ±5% CG 50V	DD95220300
C368		nsp	CER. CHIP C1608X7R1H104K	DK96104300	C684		nsp	CER. CHIP 22pF ±5% CG 50V	DD95220300
C369		nsp	CER. CHIP 22pF ±5% CG 50V	DD95220300	C685		nsp	CER. CHIP C1608X7R1H104K	DK96104300
C370		nsp	CER. CHIP 22pF ±5% CG 50V	DD95220300	C715		nsp	ELECT. 47µF M 25V RA-2	OA47602520
C371		nsp	CER. CHIP 100pF ±5% CG 50V	DD95101300	C716		nsp	ELECT. 47µF M 25V RA-2	OA47602520
C372		nsp	ELECT. 10µF M 50V RA-2	OA10605020	C717		nsp	ELECT. 47µF M 25V RA-2	OA47602520
C373		nsp	CER. CHIP 47pF ±5% CG 50V	DD95470300	C718		nsp	ELECT. 47µF M 25V RA-2	OA47602520
C374		nsp	CER. CHIP 2200pF	DK96222300	C719		}		
C375		nsp	CER. CHIP C1608X7R1H104K	DK96104300	C726		nsp	CER. CHIP 47pF ±5% CG 50V	DD95470300
C601		nsp	CER. CHIP 330pF	DK96331300	C727		nsp	ELECT. 220µF M 16V RA-2	OA22701620
C602		nsp	CER. CHIP 330pF	DK96331300	C728		nsp	ELECT. 220µF M 16V RA-2	OA22701620
C603		nsp	ELECT. 47µF M 25V RA-2	OA47602520	C751		nsp	CER. CHIP 47pF ±5% CG 50V	DD95470300
C604		nsp	ELECT. 47µF M 25V RA-2	OA47602520	C752		nsp	CER. CHIP 47pF ±5% CG 50V	DD95470300
C605		nsp	ELECT. 47µF M 25V RA-2	OA47602520	C753		nsp	ELECT. 47µF M 25V RA-2	OA47602520
C606		nsp	ELECT. 47µF M 25V RA-2	OA47602520	C754		nsp	ELECT. 47µF M 25V RA-2	OA47602520
C607		nsp	ELECT. 220µF M 16V RA-2	OA22701620	C755		nsp	CER. CHIP 47pF ±5% CG 50V	DD95470300
C608		nsp	ELECT. 220µF M 16V RA-2	OA22701620	C756		nsp	CER. CHIP 47pF ±5% CG 50V	DD95470300
C609		DF15471350	FILM 470PF J M 50V	DF15471350	C757		nsp	CER. CHIP 47pF ±5% CG 50V	DD95470300
C610		DF15471350	FILM 470PF J M 50V	DF15471350	C758		nsp	CER. CHIP 47pF ±5% CG 50V	DD95470300
C611		nsp	CER. CHIP W5R 560PF	DK96561300	C771		nsp	ELECT. 47µF M 25V RA-2	OA47602520
C612		nsp	CER. CHIP W5R 560PF	DK96561300	C772		nsp	ELECT. 47µF M 25V RA-2	OA47602520
C613		nsp	ELECT. 47µF M 25V RA-2	OA47602520	C773		nsp	CER. CHIP 47pF ±5% CG 50V	DD95470300
C614		nsp	ELECT. 47µF M 25V RA-2	OA47602520	C774		nsp	CER. CHIP 47pF ±5% CG 50V	DD95470300
C615		nsp	CER. CHIP 1000pF ±10% B 50V	DK96102300	C775		nsp	ELECT. 220µF M 16V RA-2	OA22701620
C616		nsp	CER. CHIP 1000pF ±10% B 50V	DK96102300	C776		nsp	ELECT. 220µF M 16V RA-2	OA22701620
C617		nsp	CER. CHIP C1608X7R1H104K	DK96104300	CF01		nsp	CER. CHIP 47pF ±5% CG 50V	DD95470300
C618		nsp	CER. CHIP C1608X7R1H104K	DK96104300	CF02		nsp	CER. CHIP 2200pF	DK96222300
C619		nsp	ELECT. 100µF M 16V RA-2	OA10701620	CF03		nsp	CER. CHIP 0.1µF GRM39F104Z16	DK96104300
C620		nsp	ELECT. 100µF M 16V RA-2	OA10701620					
C621		nsp	CER. CHIP 47pF ±5% CG 50V	DD95470300					
C622		nsp	CER. CHIP 47pF ±5% CG 50V	DD95470300	R301		nsp	CHIP 75Ω ±5% 1/16W	NN05750610
C623		nsp	ELECT. 47µF M 25V RA-2	OA47602520	R302		nsp	CHIP 2.2kΩ ±5% 1/16W	NN05222610
C624		nsp	ELECT. 47µF M 25V RA-2	OA47602520	R303		nsp	CHIP 6.8kΩ ±5% 1/16W	NN05682610
C625		nsp	CER. CHIP W5R 560PF	DK96561300	R304		nsp	CHIP 100Ω ±5% 1/16W	NN05101610
C626		nsp	CER. CHIP W5R 560PF	DK96561300	R351		nsp	CHIP 1kΩ ±5% 1/16W	NN05102610
C631		nsp	ELECT. 470µF 16V M RA-2	OA47701620	R352		nsp	CHIP 1MΩ ±5% 1/16W	NN05105610
C650		nsp	ELECT. 47µF M 25V RA-2	OA47602520	R353		nsp	CHIP 22Ω ±5% 1/16W	NN05220610
C651		nsp	CER. CHIP 100pF ±5% CG 50V	DD95101300	R354		nsp	CHIP 75Ω ±5% 1/16W	NN05750610
C652		nsp	CER. CHIP 100pF ±5% CG 50V	DD95101300	R355		nsp	CHIP 100Ω ±5% 1/16W	NN05101610
C653		nsp	CER. CHIP 47pF ±5% CG 50V	DD95470300	R356		nsp	CHIP 100Ω ±5% 1/16W	NN05101610
C654		nsp	CER. CHIP 47pF ±5% CG 50V	DD95470300	R361		nsp	CHIP 1kΩ ±5% 1/16W	NN05102610
C655		nsp	ELECT. 47µF M 25V RA-2	OA47602520	R362		nsp	CHIP 1MΩ ±5% 1/16W	NN05105610
C656		nsp	ELECT. 47µF M 25V RA-2	OA47602520	R363		nsp	CHIP 22Ω ±5% 1/16W	NN05220610
C657		nsp	CER. CHIP W5R 560PF	DK96561300	R364		nsp	CHIP 75Ω ±5% 1/16W	NN05750610
C658		nsp	CER. CHIP W5R 560PF	DK96561300	R365		nsp	CHIP 100Ω ±5% 1/16W	NN05101610
C661		nsp	ELECT. 220µF M 16V RA-2	OA22701620	R371		nsp	CHIP 22Ω ±5% 1/16W	NN05220610
					R372		nsp	CHIP 75Ω ±5% 1/16W	NN05750610

NOTE : "nsp" PART IS LISTED FOR REFERENCE ONLY, MARANTZ WILL NOT SUPPLY THESE PARTS.

POS. NO	VERS. COLOR	PART NO. (FOR EUR)	DESCRIPTION	PART NO. (MJI)	POS. NO	VERS. COLOR	PART NO. (FOR EUR)	DESCRIPTION	PART NO. (MJI)
R601		nsp	CHIP 100Ω ±5% 1/16W	NN05101610	R686		nsp	CHIP 22kΩ ±5% 1/16W	NN05223610
R602		nsp	CHIP 100Ω ±5% 1/16W	NN05101610	R687		nsp	CHIP 22kΩ ±5% 1/16W	NN05223610
R603		nsp	CHIP 3.9kΩ ±5% 1/16W	NN05392610	R715		nsp	CHIP 33kΩ ±5% 1/16W	NN05333610
R604		nsp	CHIP 3.9kΩ ±5% 1/16W	NN05392610	R716		nsp	CHIP 33kΩ ±5% 1/16W	NN05333610
R605		nsp	CHIP 4.7kΩ ±5% 1/16W	NN05472610	R717		nsp	CHIP 33kΩ ±5% 1/16W	NN05333610
R606		nsp	CHIP 4.7kΩ ±5% 1/16W	NN05472610	R718		nsp	CHIP 33kΩ ±5% 1/16W	NN05333610
R607					R719		nsp	CHIP 1kΩ ±5% 1/16W	NN05102610
}		nsp	CHIP 10kΩ ±5% 1/16W	NN05103610	R720		nsp	CHIP 1kΩ ±5% 1/16W	NN05102610
R614					R721		RK05030950	VAR. RK09K111 50K C TYPE HORIZONTAL	RK05030950
R617		nsp	CHIP 47kΩ ±5% 1/16W	NN05473610	R722		RK05030950	VAR. RK09K111 50K C TYPE HORIZONTAL	RK05030950
R618		nsp	CHIP 47kΩ ±5% 1/16W	NN05473610					
R621		nsp	CHIP 4.7kΩ ±5% 1/16W	NN05472610	R723		nsp	CHIP 470Ω ±5% 1/16W	NN05471610
R622		nsp	CHIP 4.7kΩ ±5% 1/16W	NN05472610	R724		nsp	CHIP 470Ω ±5% 1/16W	NN05471610
R623		nsp	CHIP 4.7kΩ ±5% 1/16W	NN05472610	R725		nsp	CHIP 100kΩ ±5% 1/16W	NN05104610
R624		nsp	CHIP 4.7kΩ ±5% 1/16W	NN05472610	R726		nsp	CHIP 100kΩ ±5% 1/16W	NN05104610
R625		nsp	CHIP 10kΩ ±5% 1/16W	NN05103610	R727		nsp	CHIP 100kΩ ±5% 1/16W	NN05104610
R626		nsp	CHIP 10kΩ ±5% 1/16W	NN05103610	R728		nsp	CHIP 100kΩ ±5% 1/16W	NN05104610
R627		nsp	CHIP 10kΩ ±5% 1/16W	NN05103610	R729		nsp	CHIP 100Ω ±5% 1/16W	NN05101610
R628		nsp	CHIP 10kΩ ±5% 1/16W	NN05103610	R730		nsp	CHIP 100Ω ±5% 1/16W	NN05101610
R629		nsp	CHIP 100Ω ±5% 1/16W	NN05101610	R731		nsp	CHIP 100Ω ±5% 1/16W	NN05101610
R630		nsp	CHIP 100Ω ±5% 1/16W	NN05101610	R732		nsp	CHIP 100Ω ±5% 1/16W	NN05101610
R631		nsp	CHIP 100Ω ±5% 1/16W	NN05101610	R733				
R632		nsp	CHIP 100Ω ±5% 1/16W	NN05101610	}		nsp	CHIP 4.7kΩ ±5% 1/16W	NN05472610
R633		nsp	CHIP 4.7kΩ ±5% 1/16W	NN05472610	R737				
R634		nsp	CHIP 4.7kΩ ±5% 1/16W	NN05472610	R738		nsp	CHIP 4.7kΩ ±5% 1/16W	NN05472610
R635		nsp	CHIP 4.7kΩ ±5% 1/16W	NN05472610	R739		nsp	CHIP 2.2kΩ ±5% 1/16W	NN05222610
R636		nsp	CHIP 4.7kΩ ±5% 1/16W	NN05472610	R740		nsp	CHIP 2.2kΩ ±5% 1/16W	NN05222610
R640		nsp	CHIP 4.7kΩ ±5% 1/16W	NN05472610	R741				
R641		nsp	CHIP 100kΩ ±5% 1/16W	NN05104610	}		nsp	CHIP 4.7kΩ ±5% 1/16W	NN05472610
R642		nsp	CHIP 0Ω ±5% 1/16W	NN05000610	R748				
R643		nsp	CHIP 100Ω ±5% 1/16W	NN05101610	R751		nsp	CHIP 100kΩ ±5% 1/16W	NN05104610
R644		nsp	CHIP 4.7kΩ ±5% 1/16W	NN05472610	R752		nsp	CHIP 100kΩ ±5% 1/16W	NN05104610
R645		nsp	CHIP 100kΩ ±5% 1/16W	NN05104610	R753				
R646		nsp	CHIP 4.7kΩ ±5% 1/16W	NN05472610	}		nsp	CHIP 4.7kΩ ±5% 1/16W	NN05472610
R647		nsp	CHIP 100kΩ ±5% 1/16W	NN05104610	R760				
R648		nsp	CHIP 4.7kΩ ±5% 1/16W	NN05472610	R761		nsp	CHIP 15kΩ ±5% 1/16W	NN05153610
R649		nsp	CHIP 100kΩ ±5% 1/16W	NN05104610	R762		nsp	CHIP 15kΩ ±5% 1/16W	NN05153610
R650		nsp	CHIP 2.2kΩ ±5% 1/16W	NN05222610	R765		nsp	CHIP 100kΩ ±5% 1/16W	NN05104610
R651		nsp	CHIP 22kΩ ±5% 1/16W	NN05223610	R771		nsp	CHIP 10kΩ ±5% 1/16W	NN05103610
R651		nsp	CHIP 2.2kΩ ±5% 1/16W	NN05222610	R772		nsp	CHIP 10kΩ ±5% 1/16W	NN05103610
R652					R773		nsp	CHIP 4.7kΩ ±5% 1/16W	NN05472610
}		nsp	CHIP 2.2kΩ ±5% 1/16W	NN05222610	R774		nsp	CHIP 4.7kΩ ±5% 1/16W	NN05472610
R658					R775		nsp	CHIP 3.3kΩ ±5% 1/16W	NN05332610
R659		nsp	CHIP 4.7kΩ ±5% 1/16W	NN05472610	R776		nsp	CHIP 3.3kΩ ±5% 1/16W	NN05332610
R660		nsp	CHIP 4.7kΩ ±5% 1/16W	NN05472610	R777		nsp	CHIP 15kΩ ±5% 1/16W	NN05153610
R661		nsp	CHIP 4.7kΩ ±5% 1/16W	NN05472610	R778		nsp	CHIP 15kΩ ±5% 1/16W	NN05153610
R662		nsp	CHIP 4.7kΩ ±5% 1/16W	NN05472610	R779		nsp	CHIP 15kΩ ±5% 1/16W	NN05153610
R663		nsp	CHIP 10kΩ ±5% 1/16W	NN05103610	R780		nsp	CHIP 15kΩ ±5% 1/16W	NN05153610
R664		nsp	CHIP 10kΩ ±5% 1/16W	NN05103610	R781		nsp	CHIP 100Ω ±5% 1/16W	NN05101610
R665		nsp	CHIP 10kΩ ±5% 1/16W	NN05103610	R782		nsp	CHIP 100Ω ±5% 1/16W	NN05101610
R666		nsp	CHIP 10kΩ ±5% 1/16W	NN05103610					
R667		nsp	CHIP 100Ω ±5% 1/16W	NN05101610	RF01		nsp	CHIP 100Ω ±5% 1/16W	NN05101610
R668		nsp	CHIP 100Ω ±5% 1/16W	NN05101610	RF02		nsp	CHIP 10kΩ ±5% 1/16W	NN05103610
R669		nsp	CHIP 100Ω ±5% 1/16W	NN05101610	RF03		nsp	CHIP 22Ω ±5% 1/16W	NN05220610
R670		nsp	CHIP 100Ω ±5% 1/16W	NN05101610					
R671									
}		nsp	CHIP 4.7kΩ ±5% 1/16W	NN05472610					
R675								<b>P716-SEMICONDUCTORS</b>	
R676		nsp	CHIP 100kΩ ±5% 1/16W	NN05104610	D631		HZ20018050	CHIP DIODE 1SS302	HZ20018050
R677		nsp	CHIP 2.7kΩ ±5% 1/16W	NN05272610	D632		HD30821000	ZENER DIODE 8.2V	HD30821000
R678		nsp	CHIP 4.7kΩ ±5% 1/16W	NN05472610	D633		HD30821000	ZENER DIODE 8.2V	HD30821000
R679		nsp	CHIP 100kΩ ±5% 1/16W	NN05104610	D771		HD30471000	ZENER DIODE 4.7V	HD30471000
R680		nsp	CHIP 22kΩ ±5% 1/16W	NN05223610	D772		HD30471000	ZENER DIODE 4.7V	HD30471000
R681		nsp	CHIP 22kΩ ±5% 1/16W	NN05223610	D773		HD30471000	ZENER DIODE 4.7V	HD30471000
R682		nsp	CHIP 2.7kΩ ±5% 1/16W	NN05272610	D774		HD30471000	ZENER DIODE 4.7V	HD30471000
R683		nsp	CHIP 3.3kΩ ±5% 1/16W	NN05332610	DF01		HZ21005000	CHIP DIODE 1SS301 DAN202U	HZ21005000
R684		nsp	CHIP 3.3kΩ ±5% 1/16W	NN05332610					
R685		nsp	CHIP 22kΩ ±5% 1/16W	NN05223610	Q301		HC700400Z0	IC 74HCU04 CMOS FLAT	HC700400Z0
					Q351		HC700805Q0	IC TC74HCT08AF	HC700805Q0

NOTE : "nsp" PART IS LISTED FOR REFERENCE ONLY, MARANTZ WILL NOT SUPPLY THESE PARTS.

POS. NO	VERS. COLOR	PART NO. (FOR EUR)	DESCRIPTION	PART NO. (MJI)	POS. NO	VERS. COLOR	PART NO. (FOR EUR)	DESCRIPTION	PART NO. (MJI)
Q361		HC700000Z0	IC 74HC00 CMOS FLAT	HC700000Z0	L351		TP41042030	PULSE TRANSF.	TP41042030
Q601		HC10011090	IC NJM4558M(Y)	HC10011090				TPS247MN-0386AN	
Q602		HC10011090	IC NJM4558M(Y)	HC10011090	L361		TP41042030	PULSE TRANSF.	TP41042030
Q603		HC40522110	IC BU4052BCF C-MOS	HC40522110				TPS247MN-0386AN	
Q604		HC40522110	IC BU4052BCF C-MOS	HC40522110	L371		TP41042030	PULSE TRANSF.	TP41042030
Q621		BA20016050	DIG. TRS.	BA20016050				TPS247MN-0386AN	
			HN1C03F(B)(NPNX2(MUTING))		L621		FC90020110	FERRITE CHIP BLM11B601S	FC90020110
Q622		BA20016050	DIG. TRS.	BA20016050	L622				
			HN1C03F(B)(NPNX2(MUTING))		}		FC90020110	FERRITE CHIP BLM11B601S	FC90020110
Q631		BA20035210	DIG. TRS. DTC114EU	BA20035210	L626				
Q632		BA20035210	DIG. TRS. DTC114EU	BA20035210	L651		FC90020110	FERRITE CHIP BLM11B601S	FC90020110
Q633		HX100012A0	CHIP TRS. 2SA1586 (Y GR)	HX100012A0	L652		FC90020110	FERRITE CHIP BLM11B601S	FC90020110
			2SA1576A (Q R)		L751		FC90020110	FERRITE CHIP BLM11B601S	FC90020110
Q634		HX100012A0	CHIP TRS. 2SA1586 (Y GR)	HX100012A0	L752		FC90020110	FERRITE CHIP BLM11B601S	FC90020110
			2SA1576A (Q R)		LF01		FC90020110	FERRITE CHIP BLM11B601S	FC90020110
Q635		BA20035210	DIG. TRS. DTC114EU	BA20035210					
Q636		HX300012A0	CHIP TRS.	HX300012A0	S751		SS02021150	SLIDE SWITCH CINCH/XLR	SS02021150
			2SC4081 (Q R) 2SC4116 (Y GR)		SF01		SS02021150	SLIDE SWITCH INT/EXT	SS02021150
Q637		HX100012A0	CHIP TRS. 2SA1586 (Y GR)	HX100012A0					
			2SA1576A (Q R)						
Q638		BA20035210	DIG. TRS. DTC114EU	BA20035210					
Q639		HX300012A0	CHIP TRS.	HX300012A0					
			2SC4081 (Q R) 2SC4116 (Y GR)						
Q640		HX100012A0	CHIP TRS. 2SA1586 (Y GR)	HX100012A0	C392	nsp		ELECT. 10µF M 50V RA-2	OA10605020
			2SA1576A (Q R)		C701	}			
Q641		HX100012A0	CHIP TRS. 2SA1586 (Y GR)	HX100012A0	C710	nsp		CER. CHIP 47pF ±5% CG 50V	DD95470300
			2SA1576A (Q R)						
Q651		HC10011090	IC NJM4558M(Y)	HC10011090					
Q652		HC10011090	IC NJM4558M(Y)	HC10011090	R701	nsp		CHIP 100kΩ ±5% 1/16W	NN05104610
Q653		HC10013880	IC CS4392-KS 24BIT 192KHZ DAC	HC10013880	R702	nsp		CHIP 100kΩ ±5% 1/16W	NN05104610
Q654		HC700400Z0	IC CMOS 74HCU04 FLAT	HC700400Z0	R703	nsp		CHIP 100kΩ ±5% 1/16W	NN05104610
Q655		HC38105090	AVR NJM78L05A	HC38105090	R704	nsp		CHIP 100kΩ ±5% 1/16W	NN05104610
Q656		HC31909320	AVR PQ09RF1	HC31909320					
Q661		BA20016050	DIG. TRS.	BA20016050					
			HN1C03F(B)(NPNX2(MUTING))						
Q662		BA20016050	DIG. TRS.	BA20016050	J392	/F	nsp	OPT OUTPUT GP1FA550TZ	YJ15000190
			HN1C03F(B)(NPNX2(MUTING))		J701		YJ01004340	JACK NC3FAH2 4P	YJ01004340
Q663		BA20035210	DIG. TRS. DTC114EU	BA20035210					
Q664		HX300012A0	CHIP TRS.	HX300012A0	J702		YJ01004340	JACK NC3FAH2 4P	YJ01004340
			2SC4081 (Q R) 2SC4116 (Y GR)						
Q665		HX100012A0	CHIP TRS. 2SA1586 (Y GR)	HX100012A0	L701		FC90020110	FERRITE CHIP BLM11B601S	FC90020110
			2SA1576A (Q R)		L702		FC90020110	FERRITE CHIP BLM11B601S	FC90020110
					L703		FC90020110	FERRITE CHIP BLM11B601S	FC90020110
					L704		FC90020110	FERRITE CHIP BLM11B601S	FC90020110
Q701		HC10011090	IC NJM4558M(Y)	HC10011090					
Q702		HC10011090	IC NJM4558M(Y)	HC10011090					
Q703		HC10011090	IC NJM4558M(Y)	HC10011090	C391	nsp		ELECT. 10µF M 50V RA-2	OA10605020
Q704		HC10011090	IC NJM4558M(Y)	HC10011090	CR01	}			
Q705		HC10103090	IC NJM2082M	HC10103090		nsp		CER. CHIP C1608X7R1H104K	DK96104300
Q706		HC10103090	IC NJM2082M	HC10103090	CR05				
Q707		HC40522110	IC BU4052BCF C-MOS	HC40522110	CR06	nsp		CER. CHIP 100pF ±5% CG 50V	DD95101300
Q708		HC10432050	IC TC9413P ELECTRIC VOLUME	HC10432050	CR07	nsp		CER. CHIP 100pF ±5% CG 50V	DD95101300
Q709		BA20035210	DIG. TRS. DTC114EU	BA20035210	CR08	nsp		CER. CHIP 100pF ±5% CG 50V	DD95101300
QF01		BA10026210	DIG. TRS. DTA114EU	BA10026210	CR09	nsp		CER. CHIP 100pF ±5% CG 50V	DD95101300
QF02		BA20035210	DIG. TRS. DTC114EU	BA20035210	J391	/F	nsp	OPT. CONNECTOR GP1FA550TZ	YJ15000190
								OPT OUTPUT SHARP	
J301		YT02011020	TERMINAL YKC21-3639	YT02011020	JR01		YT02090160	TERMINAL D-SUB 9PIN F	YT02090160
J311		YJ15000180	OPT RECEIVER GP1FA550RZ	YJ15000180	QR01		HC10204990	IC HIN202ECB	HC10204990
J351		YT02010780	TERMINAL CINCH 14X14 RA 1L1P	YT02010780				16LEAD WIDE BODY	
			BLK NI FLM-GND						
J361		YT02021220	TERMINAL CINCH 14X14 RA 2L2P	YT02021220					
			BLK NI FLM-GND						
J621		YT02021210	TERMINAL CINCH 14X14 RA 2L2P	YT02021210	C801	nsp		CER. CHIP 82pF	DD95820300
			W/R AU FRNT-GND		C802	nsp		CER. CHIP 820pF ± 10%	DK96821300
J661		YT02021210	TERMINAL CINCH 14X14 RA 2L2P	YT02021210	C803	nsp		CER. CHIP 470pF	DK96471300
			W/R AU FRNT-GND		C804	nsp		CER. CHIP 4700pF ±10% B 50V	DK96472300
J751		YT02021210	TERMINAL 14X14 RA 2L2P W/R AU	YT02021210	C809	nsp		CER. CHIP 1500pF	DK96152300
			FRNT-GND		C810	nsp		ELECT. 2.2µF M 50V RA-2	OA22505020
JF01		YT02021090	TERMINAL CINCH YKC21-3339	YT02021090	C814	nsp		CER. CHIP C1608X7R1H104K	DK96104300
			CINCH PIN JACK ORG		▲ C819		DF17104630	FILM ECQUL 0.1µF/250V AC	DF17104630

NOTE : "nsp" PART IS LISTED FOR REFERENCE ONLY, MARANTZ WILL NOT SUPPLY THESE PARTS.

POS. NO	VERS. COLOR	PART NO. (FOR EUR)	DESCRIPTION	PART NO. (MJI)	POS. NO	VERS. COLOR	PART NO. (FOR EUR)	DESCRIPTION	PART NO. (MJI)
▲ C820		DF17224570	FILM ECQUL 0.22μF/250V AC	DF17224570	R883		nsp	CHIP 1.8kΩ ±5% 1/16W	NN05182610
▲ C821		EA12740070	ELECT CAP. RE3-400V121MK9	EA12740070	R887		nsp	CHIP 100Ω ±5% 1/16W	NN05101610
▲ C825		nsp	120μF/400V CER. 470pF AC400V	DK17471520	R891		nsp	CHIP 22kΩ ±5% 1/16W	NN05223610
▲ C826		nsp	DE0910-1B471K-KX CER. 470pF AC400V	DK17471520	R892		nsp	CHIP 22kΩ ±5% 1/16W	NN05223610
▲ C827		nsp	DE0910-1B471K-KX CER. 470P 1KV	DK16471560	R893		nsp	CHIP 10kΩ ±5% 1/16W	NN05103610
▲ C828		nsp	DE0705-979R471K1K CER. 470pF AC400V	DK17471520				<b>P816-SEMICONDUCTORS</b>	
C829		nsp	DE0910-1B471K-KX ELECT. 4.7μF M 50V RA-2	OA47505020	▲ D802		nsp	DIODE S1WB(A)60 30A 600V	HD20031290
C833		nsp	ELECT. 100μF M 25V RA-2	OA10702520	▲ D803		nsp	DIODE AG01 400V 0.7A	HD20049080
C834		nsp	ELECT. 22μF M 50V RA-2	OA22605020	▲ D804		nsp	DIODE AG01 400V 0.7A	HD20049080
C840		nsp	CER. CHIP C1608X7R1H104K	DK96104300	▲ D806		nsp	DIODE AG01 400V 0.7A	HD20049080
C844		nsp	CER. CHIP C1608X7R1H104K	DK96104300	▲ D807		nsp	DIODE AG01 400V 0.7A	HD20049080
C851		nsp	ELECT. 330μF M 16V RA-2	OA33701620	▲ D814		nsp	DIODE AG01 400V 0.7A	HD20049080
C852		nsp	ELECT. 100μF M 16V RA-2	OA10701620	▲ D829		HD32401000	ZENER DIODE 24V	HD32401000
C853		nsp	CER. CHIP C1608X7R1H104K	DK96104300	▲ D832		nsp	DIODE AG01	HD20049080
C854		nsp	ELECT. 10μF M 50V RA-2	OA10605020	▲ D851		nsp	DIODE AG01	HD20049080
C855		nsp	CER. CHIP C1608X7R1H104K	DK96104300	▲ D856		nsp	DIODE RK46	HD20050080
C856		nsp	ELECT. 2200μF 16V	OA22801620	▲ D861		nsp	DIODE AG01	HD20049080
C857		nsp	ELECT. 100μF M 10V RA-2	OA10701020	D862		HD32401000	ZENER DIODE 24V	HD32401000
C858		nsp	CER. CHIP C1608X7R1H104K	DK96104300	▲ D866		nsp	DIODE RU4AM 600V 2.0A	HD20051080
C861		nsp	ELECT. 10μF M 50V RA-2	OA10605020	D868		nsp	DIODE AG01 400V 0.7A	HD20049080
C862		nsp	ELECT. 10μF M 50V RA-2	OA10605020	▲ D871		nsp	DIODE AG01	HD20049080
C863		nsp	ELECT. 10μF M 50V RA-2	OA10605020	▲ D876		nsp	DIODE AG01	HD20049080
C864		nsp	ELECT. 10μF M 50V RA-2	OA10605020					
C866		nsp	CER. CHIP C1608X7R1H104K	DK96104300	▲ Q801		HW10032320	PHOTO UNIT PC-123F2	HW10032320
C867		nsp	ELECT. 1000μF M 16V RA-2	OA10801620	▲ Q810		HC10111170	IC MC44603P	HC10111170
C868		nsp	ELECT. 100μF M 25V RA-2	OA10702520	▲ Q825		HF22943000	F.E.T. 2SK2943 900V 3A	HF22943000
C870		nsp	ELECT. 10μF M 50V RA-2	OA10605020	▲ Q851		HC31937590	AVR LM317 ADJ. REG.	HC31937590
C871		nsp	CER. CHIP C1608X7R1H104K	DK96104300	Q861		HX300012A0	CHIP TRS.	HX300012A0
C872		nsp	ELECT. 220μF M 16V RA-2	OA22701620	Q862		HX100012A0	2SC4081 (Q R) 2SC4116 (Y GR) CHIP TRS. 2SA1586 (Y GR)	HX100012A0
C873		nsp	ELECT. 100μF M 16V RA-2	OA10701620	Q866		HC3890809F	IC NJM7808FA AVR +8V 1A REG.	HC3890809F
C875		nsp	CER. CHIP C1608X7R1H104K	DK96104300	Q871		HC38112090	IC AVR NJM78L12A	HC38112090
C876		nsp	CER. CHIP C1608X7R1H104K	DK96104300	Q876		HC39112090	IC AVR NJM 79L12A	HC39112090
C877		nsp	ELECT. 220μF M 16V RA-2	OA22701620	Q881		HC33036590	IC AVR TL431 SHUNT REG.	HC33036590
C878		nsp	ELECT. 100μF M 25V RA-2	OA10702520	Q891		HX300012A0	CHIP TRS.	HX300012A0
C880		nsp	CER. CHIP C1608X7R1H104K	DK96104300	Q892		HW10032320	2SC4081 (Q R) 2SC4116 (Y GR) PHOTO UNIT PC-123F2	HW10032320
C881		nsp	ELECT. 100μF M 16V RA-2	OA10701620				<b>P816-MISCELLANEOUS</b>	
C882		nsp	CER. CHIP 0.022μF ±10% XTR 16V	DK96223200	▲ F820	/F/N	FS10200850	FUSE 2A 250V BS LISTED	FS10200850
C891		nsp	ELECT. 100μF 25V	OA10702520	▲ F820	/U	nsp	FUSE 2A 125V UL CSA MITI FBT	FS10200350
C892		nsp	ELECT. 100μF 25V	OA10702520	▲ J801		YP04000760	PLUG CONNECTOR 2P B3P-VH	YP04000760
R801		nsp	<b>P816-RESISTORS</b> CHIP 82kΩ ±5% 1/16W	NN05823610	▲ L820		LC22260130	CHOKE COIL LF-4D-223 LINE FILTER 22MH	LC22260130
R802		nsp	CHIP 22kΩ ±5% 1/16W	NN05223610	L825		FC90050130	FERRITE CORE BL02RN2-R62T2 FERRITE BEAD	FC90050130
R803		nsp	CHIP 4.7kΩ ±5% 1/16W	NN05472610	▲ L831		TS12900010	POWER TRANSF. ER2810SG SWITVING TRANSF.	TS12900010
R804		nsp	CHIP 15kΩ ±5% 1/16W	NN05153610	L832		LC11033900	CHOKE COIL SUBSTITUTE COIL 10μH J%	LC11033900
R805		nsp	CHIP 15kΩ ±5% 1/16W	NN05153610	L851		LC14723900	CHOKE COIL SUBSTITUTE COIL 4.7μH J%	LC14723900
R807		nsp	CHIP 180kΩ ±5% 1/16W	NN05184610	L852		LC14723900	CHOKE COIL SUBSTITUTE COIL 4.7μH J%	LC14723900
R808		nsp	CHIP 18kΩ ±5% 1/16W	NN05183610	L856		LC16820110	CHOKE COIL PJ8R-6R8M	LC16820110
R809		nsp	CHIP 330Ω ±5% 1/16W	NN05331610	L861		LC14723900	CHOKE COIL 4.7μH EL0405	LC14723900
R810		nsp	CHIP 10kΩ ±5% 1/16W	NN05103610	L866		LC16820110	CHOKE COIL 6.8μH PJ8R-6R8M	LC16820110
R814		nsp	CHIP 1.8kΩ ±5% 1/16W	NN05182610	L871		LC14723900	CHOKE COIL 4.7μH EL0405	LC14723900
R815		nsp	CHIP 1.8kΩ ±5% 1/16W	NN05182610	L876		LC14723900	CHOKE COIL 4.7μH EL0405	LC14723900
R816		nsp	CHIP 180Ω ±5% 1/16W	NN05181610	L880		FC90050130	FERRITE BEAD BL02RN2-R62T2	FC90050130
▲ R819	/F	nsp	330Ω K 1/2W ERC12GK334C	RC10334120	L886		SP01012480	PUSH SW. TV-5 1.5MM	SP01012480
▲ R819	/N	RC05105010	1M Ω ±5% 1W RCR60 L15	RC05105010	▲ S801				
▲ R819	/U	nsp	2.2M Ω 1/2W ERC12UG	RC10225820					
R861		nsp	CHIP 10kΩ ±5% 1/16W	NN05103610					
R862		nsp	CHIP 22kΩ ±5% 1/16W	NN05223610					
R863		nsp	CHIP 10kΩ ±5% 1/16W	NN05103610					
R864		nsp	CHIP 10kΩ ±5% 1/16W	NN05103610					
R881		nsp	CHIP 3.3kΩ ±5% 1/16W	NN05332610					
R882		nsp	CHIP 100Ω ±5% 1/16W	NN05101610					

NOTE : "nsp" PART IS LISTED FOR REFERENCE ONLY, MARANTZ WILL NOT SUPPLY THESE PARTS.

POS. NO	VERS. COLOR	PART NO. (FOR EUR)	DESCRIPTION	PART NO. (MJI)	POS. NO	VERS. COLOR	PART NO. (FOR EUR)	DESCRIPTION	PART NO. (MJI)
			<b>P916 HEADPHONE CIRCUIT BOARD</b>						
			<b>P916-CAPACITORS</b>						
C901	nsp		CER. CHIP 2200pF	DK96222300	C126	nsp	CER. CHIP 1000pF ±10% B 50V	DK96102300	
C902	nsp		CER. CHIP 2200pF	DK96222300	C127	nsp	CER. CHIP C1608X7R1H104K	DK96104300	
C903	nsp		CER. CHIP 47pF ±5% CG 50V	DD95470300	C128	nsp	CER. CHIP C1608X7R1H104K	DK96104300	
C904	nsp		CER. CHIP 47pF ±5% CG 50V	DD95470300	C129	nsp	CER. CHIP 1000pF ±10% B 50V	DK96102300	
C907	nsp		CER. CHIP 47pF ±5% CG 50V	DD95470300	C130	nsp	CER. CHIP C1608X7R1H104K	DK96104300	
C908	nsp		CER. CHIP 47pF ±5% CG 50V	DD95470300	C131	nsp	CER. CHIP 1000pF ±10% B 50V	DK96102300	
C911	nsp		CER. CHIP 560pF W5R	DK96561300	C132	}			
C912	nsp		CER. CHIP 560pF W5R	DK96561300	}	nsp	CER. CHIP C1608X7R1H104K	DK96104300	
C913	nsp		CER. CHIP C1608X7R1H104K	DK96104300	C137				
C914	nsp		CER. CHIP 2200pF	DK96222300	C150	nsp	CER. CHIP 0.047µF ±10% X7R 16V	DK96473200	
			<b>P916-RESISTORS</b>		C151	nsp	CER. CHIP 1000pF ±10% B 50V	DK96102300	
R901	nsp		CHIP 47kΩ ±5% 1/16W	NN05473610	C152	nsp	CER. CHIP 0.01µF ±10% 50V	DK96103300	
R902	nsp		CHIP 47kΩ ±5% 1/16W	NN05473610			C1608JB1H103K		
R903	RM01031170		VAR. 10K B	RM01031170	C153	nsp	CER. CHIP 1µF 10V F	DK98105200	
			RK09L12B0 (D-CUT REVERSE)		C154	nsp	CER. CHIP 47pF ±5% CG 50V	DD95470300	
R905	nsp		CHIP 4.7kΩ ±5% 1/16W	NN05472610	C155	nsp	CER. CHIP 0.022µF ±10% XTR 16V	DK96223200	
R906	nsp		CHIP 4.7kΩ ±5% 1/16W	NN05472610	C158	nsp	CER. CHIP 22pF ±5% CG 50V	DD95220300	
R907	nsp		CHIP 15kΩ ±5% 1/16W	NN05153610	C159	nsp	CER. CHIP 22pF ±5% CG 50V	DD95220300	
R908	nsp		CHIP 15kΩ ±5% 1/16W	NN05153610	C163	nsp	CER. CHIP 180pF	DD95181300	
R909	nsp		CHIP 10kΩ ±5% 1/16W	NN05103610	C164	nsp	CER. CHIP 220pF	DK96221300	
R910	nsp		CHIP 10kΩ ±5% 1/16W	NN05103610	C165	nsp	CER. CHIP 220pF	DK96221300	
R911	nsp		CHIP 75Ω ±5% 1/16W	NN05750610	C166	nsp	CER. CHIP 330pF	DK96331300	
R912	nsp		CHIP 75Ω ±5% 1/16W	NN05750610	C167	nsp	CER. CHIP 180pF	DD95181300	
R913	nsp		CHIP 75Ω ±5% 1/16W	NN05750610	C168	nsp	CER. CHIP 220pF	DK96221300	
R914	nsp		CHIP 75Ω ±5% 1/16W	NN05750610	C169	nsp	CER. CHIP 220pF	DK96221300	
R915	nsp		CHIP 4.7kΩ ±5% 1/16W	NN05472610					
R916	nsp		CHIP 4.7kΩ ±5% 1/16W	NN05472610	C170	nsp	CER. CHIP 180pF	DD95181300	
R917	nsp		CHIP 4.7kΩ ±5% 1/16W	NN05472610	C171	nsp	CER. CHIP 220pF	DK96221300	
R918	nsp		CHIP 4.7kΩ ±5% 1/16W	NN05472610	C173	nsp	CER. CHIP 180pF	DD95181300	
			<b>P916-SEMICONDUCTORS</b>		C174	nsp	CER. CHIP 220pF	DK96221300	
Q901	HC10045090		IC NJM-4558MB	HC10045090	C175	nsp	CER. CHIP 1µF 10V F	DK98105200	
Q903	BA20016050		DIG. TRS. HN1C03F (B)(NPNX2(MUTING))	BA20016050	C176	nsp	CER. CHIP 22pF ±5% CG 50V	DD95220300	
Q904	BA20016050		DIG. TRS. HN1C03F (B)(NPNX2(MUTING))	BA20016050	C177	nsp	CER. CHIP 22pF ±5% CG 50V	DD95220300	
			<b>P916-MISCELLANEOUS</b>		C179	nsp	CER. CHIP C1608X7R1H104K	DK96104300	
J905	YJ01003020		JACK ST HEADPHONE BLK/GOLD	YJ01003020	C183	nsp	CER. CHIP 0.01µF ±10% B 25V	DK96103200	
L901	FC90020110		CHIP FERRITE	FC90020110	C184	nsp	CER. CHIP 22pF ±5% CG 50V	DD95220300	
L907			BLM11B601S		C185	nsp	CER. CHIP C1608X7R1H104K	DK96104300	
			<b>PS16-SERVO/MP3/CPU CIRCUIT BOARD</b>		C186	nsp	CER. CHIP 1500pF	DK96152300	
			<b>PS16-CAPACITORS</b>		C187	nsp	CER. CHIP C1608X7R1H104K	DK96104300	
C101	nsp		CER. CHIP 5pF ±0.25pF CH 50V	DD90050300	C189	nsp	CER. CHIP C1608X7R1H104K	DK96104300	
C102	nsp		CER. CHIP 0.01µF ±10% 50V	DK96103300	C190	nsp	CER. CHIP 22pF ±5% CG 50V	DD95220300	
			C1608JB1H103K		C191	nsp	CER. CHIP 1500pF	DK96152300	
C103	nsp		CER. CHIP C1608X7R1H104K	DK96104300	C192	nsp	CER. CHIP C1608X7R1H104K	DK96104300	
C104	nsp		CER. CHIP 4700pF ±10% B 50V	DK96472300	C193	nsp	CER. CHIP 1µF 10V F	DK98105200	
C111	nsp		CER. CHIP C1608X7R1H104K	DK96104300	C251	nsp	CER. CHIP C1608X7R1H104K	DK96104300	
C112	nsp		CER. CHIP C1608X7R1H104K	DK96104300	C252	nsp	CER. CHIP C1608X7R1H104K	DK96104300	
C113	nsp		CER. CHIP C1608X7R1H104K	DK96104300	C253	nsp	CER. CHIP C1608X7R1H104K	DK96104300	
C114	nsp		CER. CHIP C1608X7R1H104K	DK96104300	C254	nsp	CER. CHIP 22pF ±5% CG 50V	DD95220300	
C115	nsp		CER. CHIP 1000pF ±10% B 50V	DK96102300					
C116	nsp		CER. CHIP 1000pF ±10% B 50V	DK96102300	CM03	nsp	CER. CHIP C1608X7R1H104K	DK96104300	
C117	nsp		CER. CHIP C1608X7R1H104K	DK96104300	CM04	nsp	CER. CHIP C1608X7R1H104K	DK96104300	
C118	nsp		CER. CHIP C1608X7R1H104K	DK96104300	CM05	nsp	CER. CHIP C1608X7R1H104K	DK96104300	
C119	nsp		CER. CHIP C1608X7R1H104K	DK96104300	CM06	nsp	CER. CHIP C1608X7R1H104K	DK96104300	
C120	nsp		CER. CHIP C1608X7R1H104K	DK96104300	CM07	nsp	CER. CHIP C1608X7R1H104K	DK96104300	
C121	nsp		CER. CHIP 1000pF ±10% B 50V	DK96102300	CM08	nsp	CER. CHIP C1608X7R1H104K	DK96104300	
C122	nsp		CER. CHIP C1608X7R1H104K	DK96104300	CM09	nsp	CER. CHIP C1608X7R1H104K	DK96104300	
C123	nsp		CER. CHIP C1608X7R1H104K	DK96104300	CM10	nsp	CER. CHIP C1608X7R1H104K	DK96104300	
C124	nsp		CER. CHIP C1608X7R1H104K	DK96104300	CM11	nsp	CER. CHIP C1608X7R1H104K	DK96104300	
C125	nsp		CER. CHIP C1608X7R1H104K	DK96104300	CM13	nsp	CER. CHIP 4700pF ±10% B 50V	DK96472300	
					CM14	nsp	CER. CHIP 470pF	DK96471300	
					CM15	nsp	CER. CHIP C1608X7R1H104K	DK96104300	
					CM16	nsp	CER. CHIP C1608X7R1H104K	DK96104300	
					CM17	nsp	CER. CHIP 22pF ±5% CG 50V	DD95220300	
					CM18	nsp	CER. CHIP 22pF ±5% CG 50V	DD95220300	
					CM19	nsp	CER. CHIP 22pF ±5% CG 50V	DD95220300	
					CM20	nsp	CER. CHIP 22pF ±5% CG 50V	DD95220300	
					CM23	nsp	CER. CHIP 470pF	DK96471300	
					CM24	nsp	CER. CHIP 4700pF ±10% B 50V	DK96472300	
					CU01	nsp	CER. CHIP C1608X7R1H104K	DK96104300	
					CU02	nsp	CER. CHIP C1608X7R1H104K	DK96104300	

NOTE : "nsp" PART IS LISTED FOR REFERENCE ONLY, MARANTZ WILL NOT SUPPLY THESE PARTS.



POS. NO	VERS. COLOR	PART NO. (FOR EUR)	DESCRIPTION	PART NO. (MJI)	POS. NO	VERS. COLOR	PART NO. (FOR EUR)	DESCRIPTION	PART NO. (MJI)
CU03		nsp	CER. CHIP C1608X7R1H104K	DK96104300	R166		nsp	CHIP 47Ω ±5% 1/16W	NN05470610
CU04		nsp	CER. CHIP C1608X7R1H104K	DK96104300	R167		nsp	CHIP 33kΩ ±5% 1/16W	NN05333610
CU05		nsp	CER. CHIP C1608X7R1H104K	DK96104300	R168		nsp	CHIP 22Ω ±5% 1/16W	NN05220610
CU06		nsp	CER. CHIP C1608X7R1H104K	DK96104300	R169		nsp	CHIP 22Ω ±5% 1/16W	NN05220610
CU07		nsp	CER. CHIP C1608X7R1H104K	DK96104300	R171		nsp	CHIP 2.2kΩ ±5% 1/16W	NN05222610
CU08		nsp	CER. CHIP 47pF ±5% CG 50V	DD95470300	R172		nsp	CHIP 1kΩ ±5% 1/16W	NN05102610
CU09		nsp	CER. CHIP 47pF ±5% CG 50V	DD95470300	R174		nsp	CHIP 1kΩ ±5% 1/16W	NN05102610
CU10		nsp	CER. CHIP 47pF ±5% CG 50V	DD95470300	R175		nsp	CHIP 0Ω ±5% 1/16W	NN05000610
CU11		nsp	CER. CHIP C1608X7R1H104K	DK96104300	R176		nsp	CHIP 10kΩ ±5% 1/16W	NN05103610
CU12		nsp	CER. CHIP 47pF ±5% CG 50V	DD95470300	R177		nsp	CHIP 100Ω ±5% 1/16W	NN05101610
CU13		nsp	CER. CHIP 47pF ±5% CG 50V	DD95470300	R178		nsp	CHIP 1kΩ ±5% 1/16W	NN05102610
CU14		nsp	CER. CHIP 47pF ±5% CG 50V	DD95470300	R179		nsp	CHIP 4.7Ω ±5% 1/16W	NN05047610
CU15		nsp	CER. CHIP 47pF ±5% CG 50V	DD95470300	R181		nsp	CHIP 47Ω ±5% 1/16W	NN05470610
			<b>PS16-RESISTORS</b>		R182		nsp	CHIP 220kΩ ±5% 1/16W	NN05224610
R101		nsp	CHIP 4.7kΩ ±5% 1/16W	NN05472610	R183		nsp	CHIP 10kΩ ±5% 1/16W	NN05103610
R102		nsp	CHIP 4.7kΩ ±5% 1/16W	NN05472610	R189		nsp	CHIP 10kΩ ±5% 1/16W	NN05103610
R103		nsp	CHIP 4.7kΩ ±5% 1/16W	NN05472610	R190		nsp	CHIP 10kΩ ±5% 1/16W	NN05103610
R104		nsp	CHIP 220kΩ ±5% 1/16W	NN05224610	R191		nsp	CHIP 10kΩ ±5% 1/16W	NN05103610
R105		nsp	CHIP 2.2kΩ ±5% 1/16W	NN05222610	R192		nsp	CHIP 10kΩ ±5% 1/16W	NN05103610
R106		nsp	CHIP 100kΩ ±5% 1/16W	NN05104610	R194		nsp	CHIP 10Ω ±5% 1/16W	NN05100610
R107		nsp	CHIP 15kΩ ±5% 1/16W	NN05153610	R195		nsp	CHIP 10Ω ±5% 1/16W	NN05100610
R109		nsp	CHIP 10kΩ ±5% 1/16W	NN05103610	R199		nsp	CHIP 220Ω ±5% 1/16W	NN05221610
R110		nsp	CHIP 47Ω ±5% 1/16W	NN05470610	R200		nsp	CHIP 22Ω ±5% 1/16W	NN05220610
R111		nsp	CHIP 5.6kΩ ±5% 1/16W	NN05562610	R201		nsp	CHIP 1MΩ ±5% 1/16W	NN05105610
R113		nsp	CHIP 2.7kΩ ±5% 1/16W	NN05272610	R202		nsp	CHIP 100Ω ±5% 1/16W	NN05101610
R114		nsp	CHIP 5.6kΩ ±5% 1/16W	NN05562610	R203		nsp	CHIP 10kΩ ±5% 1/16W	NN05103610
R115		nsp	CHIP 12kΩ ±5% 1/16W	NN05123610	R204		nsp	CHIP 0Ω ±5% 1/16W	NN05000610
R116		nsp	CHIP 1kΩ ±5% 1/16W	NN05102610	R205		nsp	CHIP 680Ω ±5% 1/16W	NN05681610
R117		nsp	CHIP 1.5kΩ ±5% 1/16W	NN05152610	R206		nsp	CHIP 100Ω ±5% 1/16W	NN05101610
R118		nsp	CHIP 18kΩ ±5% 1/16W	NN05183610	R207		nsp	CHIP 220Ω ±5% 1/16W	NN05221610
R119		nsp	CHIP 15kΩ ±5% 1/16W	NN05153610	R208		nsp	CHIP 100Ω ±5% 1/16W	NN05101610
R120		nsp	CHIP 12kΩ ±5% 1/16W	NN05123610	R209		nsp	CHIP 100Ω ±5% 1/16W	NN05101610
R121		nsp	CHIP 10kΩ ±5% 1/16W	NN05103610	R210		nsp	CHIP 100Ω ±5% 1/16W	NN05101610
R122		nsp	CHIP 12kΩ ±5% 1/16W	NN05123610	R211		nsp	CHIP 68Ω ±5% 1/16W	NN05680610
R123		nsp	CHIP 12kΩ ±5% 1/16W	NN05123610	R212		nsp	CHIP 5.6Ω ±5% 1/16W	NN05056610
R124		nsp	CHIP 1kΩ ±5% 1/16W	NN05102610	R213		nsp	CHIP 5.6Ω ±5% 1/16W	NN05056610
R125		nsp	CHIP 390Ω ±5% 1/16W	NN05391610	R220		nsp	CHIP 12kΩ ±5% 1/16W	NN05123610
R126		nsp	CHIP 22Ω ±5% 1/16W	NN05220610	R221		nsp	CHIP 100Ω ±5% 1/16W	NN05101610
R127		nsp	CHIP 15kΩ ±5% 1/16W	NN05153610	R226		nsp	CHIP 22Ω ±5% 1/16W	NN05220610
R129		nsp	CHIP 1kΩ ±5% 1/16W	NN05102610	R227		nsp	CHIP 0Ω ±5% 1/16W	NN05000610
					R251		nsp	CHIP 1kΩ ±5% 1/16W	NN05102610
R130		nsp	CHIP 22Ω ±5% 1/16W	NN05220610	R252		nsp	CHIP 2.2kΩ ±5% 1/16W	NN05222610
R131		nsp	CHIP 2.2kΩ ±5% 1/16W	NN05222610	R253		nsp	CHIP 2.2kΩ ±5% 1/16W	NN05222610
R132		nsp	CHIP 2.2kΩ ±5% 1/16W	NN05222610	R254		nsp	CHIP 2.2kΩ ±5% 1/16W	NN05222610
R133		nsp	CHIP 22Ω ±5% 1/16W	NN05220610	R255		nsp	CHIP 1kΩ ±5% 1/16W	NN05102610
R134		nsp	CHIP 22Ω ±5% 1/16W	NN05220610	R256		nsp	CHIP 22kΩ ±5% 1/16W	NN05223610
R135		nsp	CHIP 3.3kΩ ±5% 1/16W	NN05332610	R257		nsp	CHIP 100Ω ±5% 1/16W	NN05101610
R136		nsp	CHIP 180kΩ ±5% 1/16W	NN05184610					
R137		nsp	CHIP 100kΩ ±5% 1/16W	NN05104610	RM01		nsp	CHIP 1kΩ ±5% 1/16W	NN05102610
R138		nsp	CHIP 100kΩ ±5% 1/16W	NN05104610	RM02		nsp	CHIP 10Ω ±5% 1/16W	NN05100610
R139		nsp	CHIP 1kΩ ±5% 1/16W	NN05102610	RM03		nsp	CHIP 10Ω ±5% 1/16W	NN05100610
R140		nsp	CHIP 10kΩ ±5% 1/16W	NN05103610	RM04		nsp	CHIP 4.7Ω ±5% 1/16W	NN05047610
R141		nsp	CHIP 470Ω ±5% 1/16W	NN05471610	RM05				
R142		nsp	CHIP 2.2kΩ ±5% 1/16W	NN05222610	}		nsp	CHIP 10Ω ±5% 1/16W	NN05100610
R143		nsp	CHIP 100kΩ ±5% 1/16W	NN05104610	RM09				
R144		nsp	CHIP 1kΩ ±5% 1/16W	NN05102610	RM10	FC90020110	FERRITE CHIP BLM11B601S	FERRITE	FC90020110
R145		nsp	CHIP 100Ω ±5% 1/16W	NN05101610					
R146		nsp	CHIP 2.2kΩ ±5% 1/16W	NN05222610	RM11		nsp	CHIP 100Ω ±5% 1/16W	NN05101610
R147		nsp	CHIP 2.2kΩ ±5% 1/16W	NN05222610	RM12		nsp	CHIP 100Ω ±5% 1/16W	NN05101610
R148		nsp	CHIP 100kΩ ±5% 1/16W	NN05104610	RM13		nsp	CHIP 100Ω ±5% 1/16W	NN05101610
R149		nsp	CHIP 150kΩ ±5% 1/16W	NN05154610	RM14		nsp	CHIP 10Ω ±5% 1/16W	NN05100610
R150		nsp	CHIP 10kΩ ±5% 1/16W	NN05103610	RM15		nsp	CHIP 10Ω ±5% 1/16W	NN05100610
R151		nsp	CHIP 470Ω ±5% 1/16W	NN05471610	RM16		nsp	CHIP 1kΩ ±5% 1/16W	NN05102610
R152		nsp	CHIP 1MΩ ±5% 1/16W	NN05105610	RM17		nsp	CHIP 10Ω ±5% 1/16W	NN05100610
R153		nsp	CHIP 22kΩ ±5% 1/16W	NN05223610	RM18		nsp	CHIP 470kΩ ±5% 1/16W	NN05474610
R154		nsp	CHIP 1kΩ ±5% 1/16W	NN05102610	RM19		nsp	CHIP 470Ω ±5% 1/16W	NN05471610
R155					RM20		nsp	CHIP 1kΩ ±5% 1/16W	NN05102610
}		nsp	CHIP 10kΩ ±5% 1/16W	NN05103610	RM54		nsp	CHIP 1kΩ ±5% 1/16W	NN05102610
R165					RU01		nsp	CHIP 10kΩ ±5% 1/16W	NN05103610

NOTE : "nsp" PART IS LISTED FOR REFERENCE ONLY, MARANTZ WILL NOT SUPPLY THESE PARTS.

POS. NO	VERS. COLOR	PART NO. (FOR EUR)	DESCRIPTION	PART NO. (MJI)	POS. NO	VERS. COLOR	PART NO. (FOR EUR)	DESCRIPTION	PART NO. (MJI)
RU02		nsp	CHIP 47kΩ ±5% 1/16W	NN05473610	LM03		FC90020110	CHIP FERRITE BLM11B601S	FC90020110
RU03		nsp	CHIP 10kΩ ±5% 1/16W	NN05103610	LM04		FC90020110	CHIP FERRITE BLM11B601S	FC90020110
RU04		nsp	CHIP 10kΩ ±5% 1/16W	NN05103610					
RU05		nsp	CHIP 10kΩ ±5% 1/16W	NN05103610	X151		JX08001320	CRYSTAL CM309S 8.4672MHz	JX08001320
RU06		nsp	CHIP 1.5kΩ ±5% 1/16W	NN05152610	XU01		FQ08004070	SERAMIC VIB. CSTCC8.00MG-TC 8.000MHz	FQ08004070
RU07		nsp	CHIP 1.5kΩ ±5% 1/16W	NN05152610					
RU08		nsp	CHIP 1.5kΩ ±5% 1/16W	NN05152610					
RU09		nsp	CHIP 1.5kΩ ±5% 1/16W	NN05152610					
RU10		nsp	CHIP 100Ω ±5% 1/16W	NN05101610					
RU11		nsp	CHIP 4.7kΩ ±5% 1/16W	NN05472610					
RU12		nsp	CHIP 4.7kΩ ±5% 1/16W	NN05472610	CY14		nsp	ELECT. 100µF M 10V RA-2	OA10701020
RU13		nsp	CHIP 100Ω ±5% 1/16W	NN05101610	CY41		nsp	ELECT. 47µF M 25V RA-2	OA47602520
RU17		nsp	CHIP 100Ω ±5% 1/16W	NN05101610					
RU18		nsp	CHIP 22kΩ ±5% 1/16W	NN05223610	DY04		HD30331000	ZENER DIODE MTZ J 3.3A	HD30331000
RU19		nsp	CHIP 4.7kΩ ±5% 1/16W	NN05472610					
RU20		nsp	CHIP 47kΩ ±5% 1/16W	NN05473610	QY01		HU385KT00F	MICROPROCESSOR TMP87CH74F	HU385KT00F
RU21		nsp	CHIP 100Ω ±5% 1/16W	NN05101610	QY02		HT30001000	TRS.	HT30001000
RU22		nsp	CHIP 100Ω ±5% 1/16W	NN05101610	QY03		HT30001000	2SC2458 2SC1740S 2SC3199 ETC. TRS.	HT30001000
			<b>PS16-SEMICONDUCTORS</b>		QY04		HT30001000	2SC2458 2SC1740S 2SC3199 ETC. TRS.	HT30001000
D101		HZ21005000	CHIP DIODE 1SS301 DAN202U	HZ21005000					
D102		HZ21005000	CHIP DIODE 1SS301 DAN202U	HZ21005000					
Q101		HC10207490	IC TZA1024 (PHILIPS RF AMP)	HC10207490					
Q102		HX300012A0	CHIP TRS. 2SC4081 (Q R) 2SC4116 (Y GR)	HX300012A0	LY01		LC12243800	CHOKO COIL LAL02TA224J 220UH	LC12243800
Q103		HC10165490	IC TDA7073AT SOP DUAL BTL DRIVER	HC10165490	SY04		SP01013370	PUSH SWITCH	SP01013370
Q104		HC10165490	IC TDA7073AT SOP DUAL BTL DRIVER	HC10165490	SY13			EVQ11L05R H/5MM 160GF	
Q105		HC10165490	IC TDA7073AT SOP DUAL BTL DRIVER	HC10165490	SY15		SP01013370	PUSH SWITCH	SP01013370
Q106		BA10026210	DIG. TRS. DTA114EU	BA10026210	SY18			EVQ11L05R H/5MM 160GF	
Q107		BA20035210	DIG. TRS. DTC114EU	BA20035210	SY21		SP01013370	PUSH SWITCH	SP01013370
Q108		BA20035210	DIG. TRS. DTC114EU	BA20035210	SY23			EVQ11L05R H/5MM 160GF	
Q109		HX300012A0	CHIP TRS. 2SC4081 (Q R) 2SC4116 (Y GR)	HX300012A0	SY26		SR03030030	ROT.ENCODER WITH PUSH.SW EC11B	SR03030030
Q110		HX100012A0	CHIP TRS. 2SA1586 (Y GR) 2SA1576A (Q R)	HX100012A0	VY01		HQ31208410	FTD BJ727GNK 15GRID X 22ANODE	HQ31208410
Q111		HX300012A0	CHIP TRS. 2SC4081 (Q R) 2SC4116 (Y GR)	HX300012A0	XY01		FQ08004010	CERAMIC VIB. CST8.0MHz (MT)	FQ08004010
Q114		HC10036090	IC NJM2904M	HC10036090					
Q115		HC98A33090	IC NJM2391DL1-33 3.3V REG SMD	HC98A33090	CY07		nsp	ELECT. 100µF M 10V RA-2	OA10701020
Q116		BA10026210	DIG. TRS. DTA114EU	BA10026210	QF03		HW10008210	IR SENSOR RPM6936-H4	HW10008210
Q117		BA20035210	DIG. TRS. DTC114EU	BA20035210					
Q118		BA20035210	DIG. TRS. DTC114EU	BA20035210					
Q119		BA20035210	DIG. TRS. DTC114EU	BA20035210					
Q150		HC10209490	IC SAA7324H/M2B	HC10209490					
Q151		HC10225210	IC BU2630FV-E2 TAPING	HC10225210	DY01		HI10008340	L.E.D. HLMF-K500 #2UL GRN H=9 3MM	HI10008340
Q152		HC762837Z0	IC SN74LS628NS	HC762837Z0	DY02		HI10008340	L.E.D. HLMF-K500 #2UL GRN H=9 3MM	HI10008340
Q251		HC10390030	IC CD TEXT DECODER	HC10390030					
Q252		HC700805Q0	IC TC74HCT08AF	HC700805Q0					
QM01		HC10010540	IC STA016T MP3 DECODER	HC10010540					
QM02		HX346721A0	CHIP TRS. 2SC4672 Q	HX346721A0					
QU01		*HS12AKF0R	MICROPROCESSOR MB90F574 FLASH ROM UP 120P	*HS12AKF0R					
QU02		HC10055530	IC S-80735SN-DZ-X (RESET IC)	HC10055530					
QU03		BA10026210	DIG. TRS. DTA114EU	BA10026210					
QU04		BA10026210	DIG. TRS. DTA114EU	BA10026210					
QU11		HC10033990	IC AT24C04N-10SI-2.5	HC10033990					
			<b>PS16-MISCELLANEOUS</b>						
L101		FC90020110	CHIP FERRITE BLM11B601S	FC90020110					
L102		FC90020110	CHIP FERRITE BLM11B601S	FC90020110					
L150		FC90020110	CHIP FERRITE BLM11B601S	FC90020110					
L151		FN31000020	EMI BLM11B252SD	FN31000020					
LM01		FC90020110	CHIP FERRITE BLM11B601S	FC90020110					
LM02		FC90020110	CHIP FERRITE BLM11B601S	FC90020110					

NOTE : "nsp" PART IS LISTED FOR REFERENCE ONLY, MARANTZ WILL NOT SUPPLY THESE PARTS.