

ESPAÑOL

FRANÇAIS

ENGLISH



marantz®

Receiver
SR4023

User Guide



CAUTION

RISK OF ELECTRIC SHOCK
DO NOT OPEN



**CAUTION: TO REDUCE THE RISK OF ELECTRIC SHOCK,
DO NOT REMOVE COVER (OR BACK) NO USER-SERVICEABLE
PARTS INSIDE REFER SERVICING TO QUALIFIED
SERVICE PERSONNEL**



The lightning flash with arrowhead symbol within an equilateral triangle is intended to alert the user to the presence of uninsulated "dangerous voltage" within the product's enclosure that may be of sufficient magnitude to constitute a risk of electric shock to persons.



The exclamation point within an equilateral triangle is intended to alert the user to the presence of important operating and maintenance (servicing) instructions in the literature accompanying the product.

WARNING

**TO REDUCE THE RISK OF FIRE OR ELECTRIC SHOCK,
DO NOT EXPOSE THIS APPLIANCE TO RAIN OR MOISTURE.**

**CAUTION: TO PREVENT ELECTRIC SHOCK, MATCH WIDE BLADE OF
PLUG TO WIDE SLOT, FULLY INSERT.**

**ATTENTION: POUR EVITER LES CHOCS ELECTRIQUES, INTRODUIRE
LA LAME LA PLUS LARGE DE LA FICHE DANS LA BORNE CORRESPON-
DANTE DE LA PRISE ET POUSSER JUSQU'AU FOND.**

NOTE TO CATV SYSTEM INSTALLER:

This reminder is provided to call the CATV (Cable-TV) system installer's attention to Section 820-40 of the NEC which provides guidelines for proper grounding and, in particular, specifies that the cable ground shall be connected to the grounding system of the building, as close to the point of cable entry as practical.

NOTE:

This equipment has been tested and found to comply with the limits for a Class B digital device, pursuant to Part 15 of the FCC Rules. These limits are designed to provide reasonable protection against harmful interference in a residential installation. This equipment generates, uses and can radiate radio frequency energy and, if not installed and used in accordance with the instructions, may cause harmful interference to radio communications. However, there is no guarantee that interference will not occur in a particular installation. If this equipment does cause harmful interference to radio or television reception, which can be determined by turning the equipment off and on, the user is encouraged to try to correct the interference by one or more of the following measures:

- Reorient or relocate the receiving antenna.
- Increase the separation between the equipment and receiver.
- Connect the equipment into an outlet on a circuit different from that to which the receiver is connected.
- Consult the dealer or an experienced radio/TV technician for help.

NOTE:

Changes or modifications may cause this unit to fail to comply with Part 15 of the FCC Rules and may void the user's authority to operate the equipment.

This Class B digital apparatus complies with Canadian ICES-003.

Cet appareil numerique de la Classe B est conforme a la norme NMB-003 du Canada.

DECLARATION OF CONFORMITY

This device complies with Part 15 of the FCC rules. Operation is subject to the following conditions: (1) This device may not cause harmful interference, and (2) this device must accept any interference received, including interference that may cause undesired operation.

**U.S. Responsible Party: Marantz America, Inc.
100 Corporate Drive,
Mahwah, NJ, 07430, U.S.A.
TEL: 201-762-6500**

Type of Product: Receiver

Model: SR4023

IMPORTANT SAFETY INSTRUCTIONS

READ BEFORE OPERATING EQUIPMENT

This product was designed and manufactured to meet strict quality and safety standards. There are, however, some installation and operation precautions which you should be particularly aware of.

1. Read these instructions.
2. Keep these instructions.
3. Heed all warnings.
4. Follow all instructions.
5. Do not use this apparatus near water.
6. Clean only with dry cloth.
7. Do not block any ventilation openings. Install in accordance with the manufacture's instructions.
8. Do not install near any heat sources such as radiators, heat registers, stoves, or other apparatus (including amplifiers) that produce heat.
9. Do not defeat the safety purpose of the polarized or grounding-type plug. A polarized plug has two blades with one wider than the other. A grounding type plug has two blades and a third grounding prong. The wide blade or the third prong are provided for your safety. If the provided plug does not fit into your outlet, consult an electrician for replacement of the obsolete outlet.
10. Protect the power cord from being walked on or pinched particularly at plugs, convenience receptacles, and the point where they exit from the apparatus.
11. Only use attachments/accessories specified by the manufacturer.
12. Use only with the cart, stand, tripod, bracket, or table specified by the manufacturer, or sold with the apparatus. When a cart is used, use caution when moving the cart/apparatus combination to avoid injury from tip-over.



13. Unplug this apparatus during lightning storms or when unused for long periods of time.
14. Refer all servicing to qualified service personnel. Servicing is required when the apparatus has been damaged in any way, such as power-supply cord or plug is damaged, liquid has been spilled or objects have fallen into the apparatus, the apparatus has been exposed to rain or moisture, does not operate normally, or has been dropped.

Additional Safety Information!

- This product should not be placed in a built-in installation such as a bookcase or rack unless proper ventilation is provided or the manufacturer's instructions have been adhered to.
- Apparatus shall not be exposed to dripping or splashing and that no objects filled with liquids, such as vases, shall be placed on the apparatus.
- When the switch is in the OFF position, the apparatus isn't completely switched-off from the MAINS.
- The equipment shall be installed near the power supply so that the power supply is easily accessible.
- Do not touch hot spots during and immediately after use.
- During and immediately after use, this product is hot in areas other than the controls and rear panel connection jacks. Do not touch hot spots and especially the top panel. Contact with hot areas can cause burns.
- Do not expose the unit and batteries to excessive heat such as direct sunlight, fire or the like.
- Make a space of about 8 inches (0.2 m) around the unit.

INTRODUCTION

Thank you for purchasing the Marantz SR4023 Receiver. This remarkable component has been engineered to provide you with many years of listening enjoyment. Please take a few minutes to read this manual thoroughly before you connect and operate the SR4023. As there are a number of connection and configuration options, you are encouraged to discuss your own particular system setup with your Marantz authorized dealer.

ACCESSORIES CHECK

Before use, check the below accessories were included in the package.

Remote Controller

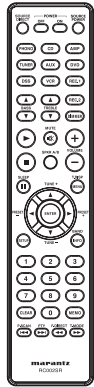

AM Loop Antenna

FM Antenna

AC Power Cable

AAA-size batteries × 2

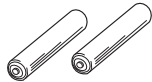

User Guide



TABLE OF CONTENTS

INTRODUCTION	1	ADVANCED CONNECTIONS	13
ACCESSORIES CHECK.....	1	CONNECTING MAIN IN JACKS.....	13
TABLE OF CONTENTS	1	CONNECTING PRE OUT JACKS	13
FEATURES	2	CONNECTING THE REMOTE CONTROL JACKS.....	14
BEFORE USE	2	ADVANCED OPERATION	15
OPERATION OF REMOTE CONTROLLER.....	3	AMPLIFIER OPERATION.....	15
NAMES AND FUNCTIONS	4	TUNER OPERATION (PRESET MEMORY).....	16
FRONT PANEL	4	REMOTE CONTROLLER OPERATION.....	18
FL DISPLAY	5	TROUBLESHOOTING	19
REMOTE CONTROLLER	6	FRONT KEY (BUTTON) LOCK OF THE UNIT.....	19
REAR PANEL	7	GENERAL MALFUNCTION	19
BASIC CONNECTIONS	8	HOW TO RESET THE UNIT	19
CONNECTING AUDIO COMPONENTS.....	8	OTHERS	20
CONNECTING VIDEO COMPONENTS.....	8	TECHNICAL SPECIFICATIONS.....	20
CONNECTING SPEAKERS.....	9	CLEANING OF EQUIPMENT EXTERNAL SURFACES.....	20
CONNECTING THE ANTENNA TERMINALS.....	10	REPAIRS.....	20
CONNECTING THE AC POWER CABLE	10		
BASIC OPERATION	11		
AMPLIFIER OPERATION.....	11		
TUNER OPERATION	12		

FEATURES

- **High quality full discrete power amplifier**
80W+80W (8 ohms, 20 Hz – 20 kHz, 0.08% THD)
- **Speaker A/B switching**
You can switch the speaker A/B via remote controller.
- **Four A/V inputs (DVD, DSS, VCR and AUX)**
- **One A/V output (VCR) and one video monitor output**
- **Four audio inputs and Two audio outputs**
Built in PHONO equalizer (MM)
- **Simulcast playback video signal of video source with audio source**
- **50 stations AM/FM random preset memory**
- **Bass and treble tone controls**
- **Source direct**
You can bypass the tone routing the audio signal directly to provide the pure sound quality.
- **PRE OUT and MAIN IN jacks**
- **Sleep timer**
- **Dimmer control**

BEFORE USE

This section must be read before any connection is made to the mains supply.

EQUIPMENT MAINS WORKING SETTING

Your Marantz product has been prepared to comply with the household power and safety requirements that exist in your area.

SR4023 can be powered by 120V AC only.

COPYRIGHT

Recording and playback of any material may require consent. For further information refer to the following:

- Copyright Act 1956
- Dramatic and Musical Performers Act 1958
- Performers Protection Acts 1963 and 1972
- Any subsequent statutory enactments and orders

DO NOT LOCATE IN THE FOLLOWING PLACES

To ensure long-lasting use, do not locate the unit where:

- Exposed to direct sunlight.
- Near to sources of heat such as heaters.
- Highly humid or poorly ventilated.
- Dusty.
- Subjected to mechanical vibrations.
- On wobbly, inclined or otherwise unstable surfaces
- Radiated heat is blocked such as in cramped audio racks.

To ensure proper heat radiation, ensure the below clearance from walls and other equipment.

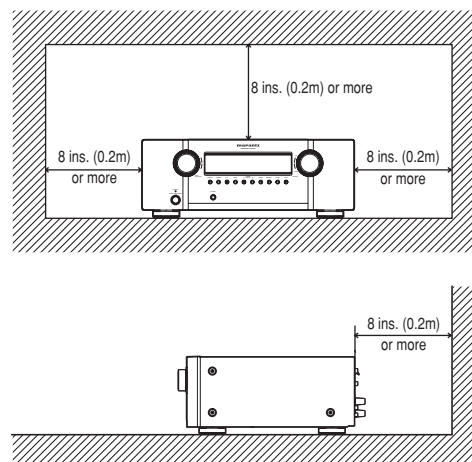

KEEP OBJECTS OFF

Keep objects off the unit. Blocking the vent can result in accident and damage.

DO NOT TOUCH HOT SPOTS DURING AND IMMEDIATELY AFTER USE

During and immediately after use, the unit is hot in areas other than the controls and rear panel connection jacks. Do not touch hot spots and especially the top panel. Contact with hot areas can cause burns.

OPERATION OF REMOTE CONTROLLER

REMOTE CONTROL

Operate the remote controller within a distance of approx. 5m from the infrared receptor window on the front of the unit.

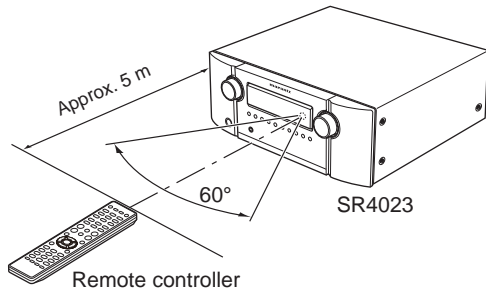

Caution:

- Do not allow direct sunlight, an inverter fluorescent light or other strong source of light to shine onto the player's infrared receptor window. Otherwise, the operation of the remote controller may be disabled.
- Bear in mind that operating the remote controller may cause other devices operated by infrared rays to be operated by mistake.
- The remote controller cannot be operated if the space between the controller and the player's infrared receptor window is obstructed.
- Do not place any objects on top of the remote controller. Doing so may cause one or more buttons to be held down which will cause the batteries to run down.

LOADING BATTERIES

Before using the remote controller for the first time, load the batteries in the remote controller. The batteries provided are used to verify the operations of the remote controller only.

1. Remove the battery cover.

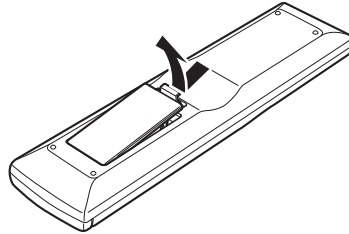

2. Load the two new size "AAA" batteries inside the battery compartment while taking care to align their polarities correctly with the polarity markings (+ with (+ and - with (-).

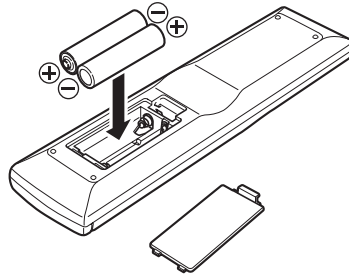

3. Close the battery cover until it clicks shut.

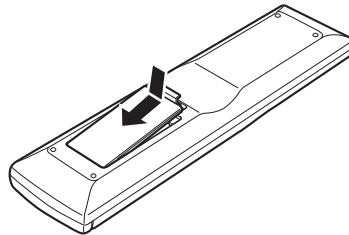

CAUTIONS ON BATTERIES

- Use "AAA" type batteries in this remote controller.
- We recommend that you use alkali batteries.
- If the remote controller does not operate from close to the unit, replace the batteries with new ones, even if less than a year has passed.
- The included battery is only for verifying operation. Replace it with a new battery as soon as possible.
- When inserting the batteries, be careful to do so in the proper direction, following the + and - marks in the remote controller's battery compartment.
- To prevent damage or battery fluid leakage:
 - Do not use a new battery with an old one.
 - Do not use two different types of batteries.
 - Do not short-circuit, disassemble, heat or dispose of batteries in flames.
- Remove the batteries when not planning to use the remote controller for a long period of time.
- If the batteries should leak, carefully wipe off the fluid from the inside of the battery compartment, then insert new batteries.
- When disposing of used batteries, please comply with governmental regulations or environmental public instruction's rules that apply in your country or area.

NAMES AND FUNCTIONS

FRONT PANEL

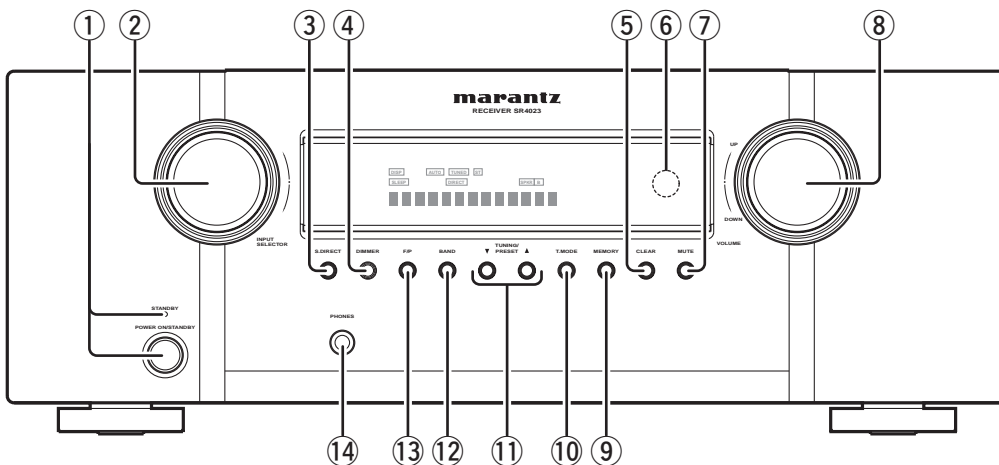

① POWER switch and STANDBY indicator

When this switch is pressed once, the unit turns ON and the display is illuminated. When pressed again, the unit turns OFF and the STANDBY indicator is illuminated.

② INPUT SELECTOR knob (AUDIO/VIDEO)

This knob is used to select the input sources. (See page 11)

③ SOURCE DIRECT button

When this button is pressed, the audio signal will bypass the tone control circuit to provide the pure sound quality.

In order not to bypass the tone control circuit, press SOURCE DIRECT button again.

④ DIMMER button

When this button is pressed once display is dimmed. When this button is pressed twice, the display is turned off and the "DISP" indicator lights up.

Press this button again to turn on the display again.

⑤ CLEAR button

Press this button to cancel the tuner preset station or preset scan tuning. (See page 15)

⑥ INFRARED receiving sensor window

This window receives infrared signals from the remote control.

⑦ MUTE button

Press this button to mute the output to the speakers. Press it again to return to the previous volume level.

⑧ VOLUME control knob

Adjusts the overall sound level. Turning the control clockwise increases the sound level.

⑨ MEMORY button

Press this button to enter the tuner preset memory numbers or station names. (See page 15)

⑩ T-MODE button

Press this button to select the auto stereo mode or mono mode when the FM band is selected.

⑪ TUNING/PRESET ▲▼ (UP/DOWN) button

This button used for tuning in the desired broadcasting stations or to preset in the desired broadcasting stations.

⑫ BAND button

Press this button to switch between FM and AM in the TUNER mode.

⑬ F (Frequency)/P (Preset) button

During reception of AM or FM, you can change the function of the UP/DOWN buttons for scanning frequencies or selecting preset stations by pressing this button.

⑭ PHONES jack for stereo headphones

Conventional dynamic headphones can be plugged in here.

Note:

When using headphones, the speaker A and/or B are switched automatically to OFF and the sound from the speakers is muted. The speaker A and/or B return to the previous setting as soon as the plug is removed from the jack.

FL DISPLAY

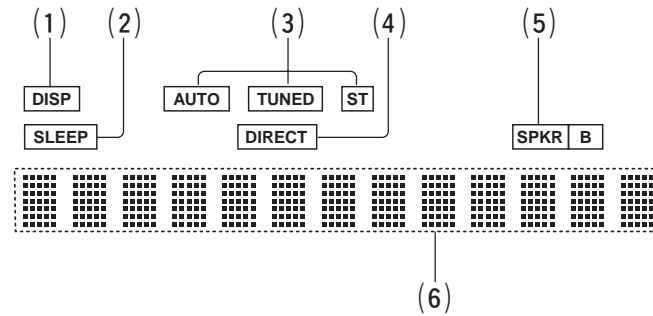
**(1) DISP (Display Off) indicator**

This indicator is illuminated when this unit is in the display off mode.

(2) SLEEP timer indicator

This indicator is illuminated when the sleep timer function is in use.

(3) TUNER's indicators

AUTO : This indicator illuminates when the tuner's Auto mode is in use.

TUNED : This indicator illuminates when the tuner receives a sufficiently strong radio signal.

ST(Stereo) : This indicator illuminates when an FM station is being tuned into stereo condition.

(4) DIRECT (Source direct) indicator

This indicator is illuminated when this unit is in the SOURCE DIRECT mode.

(5) SPKR (speaker) AB indicator

It displays the speaker system in use (A or B). When the speakers are not in use, both lights (A and B) will be turned off.

(6) Main Information Display

This display shows messages relating to the status, input source, tuner, volume level or other aspects of unit's operation.

REMOTE CONTROLLER

The provided remote controller is a system remote controller. The **POWER** button, numeric buttons and control buttons are used in common across different input source components.

The input source controlled with the remote controller changes when one of the input selector buttons is pressed.

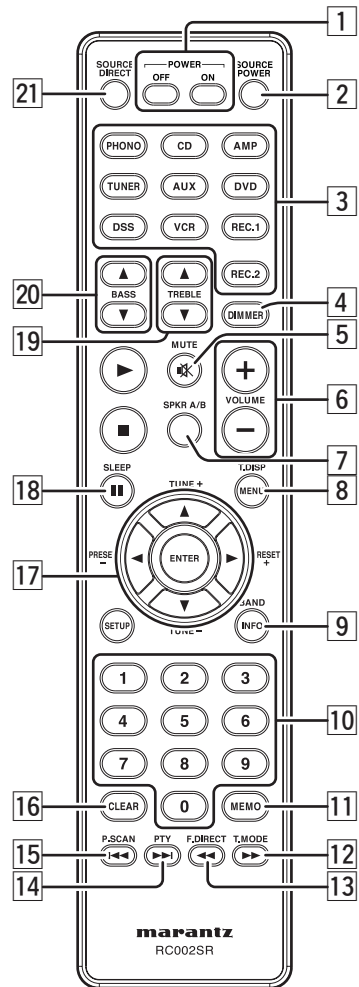

1 POWER ON and OFF buttons

(When AMP mode is selected)

These buttons are used to turn the unit on or off.

2 SOURCE POWER button

Press to switch the power of the source component after pressing the function selector button.

3 Input selector buttons / FUNCTION SELECTOR buttons (AUDIO / VIDEO INPUT)

These buttons are used to select a Audio or Video source component. When one of these buttons is pressed, the input function of the unit is changed. Audio function sources such as PHONO, CD, TUNER, RECORDER1 and RECORDER2 may be selected in conjunction with a Video source. This feature (Sound Injection) combines a sound from one source with a picture from another. Choose the video source first, and then choose a different audio source to activate this function.

4 DIMMER button

When this button is pressed once, the display is dimmed. When this button is pressed twice, the display is turned off and the "DISP" indicator lights up. Press this button again to turn on the display again.

5 MUTE button

Press this button decrease the sound temporarily. Press this button again to return to the previous sound level.

6 VOLUME +/- buttons

This button is used to adjust the volume for the amplifier.

7 SPKR A/B button

This button is used to select the speaker system. The speaker system is switched in the following sequence.
A+B → A → B → A+B

8 T.DISP button

This button is not used for SR4023.

9 BAND button

(When TUNER mode is selected)

This button is used to select a radio band.

10 Numeric buttons 0 to 9

These buttons are used to enter figures in the selection of a tuner preset station and station name preset or to set select a DVD chapter or title and a CD track number, etc. The functions of these buttons are dependent on the function button selected.

11 MEMO button

This button is used to store frequencies and station names in memory.

12 T.MODE button

(When TUNER mode is selected)

This button is used to select auto stereo mode or mono mode when the FM band is selected. The "AUTO" indicator lights in the auto stereo mode.

13 F.DIRECT button

(When TUNER mode is selected)

This button is used to select the "Frequency direct input".

14 PTY button

This button is not used for SR4023.

15 P.SCAN button

(When tuner mode is selected)

This button is used to start preset scan.

16 CLEAR button

This button is used to cancel for certain memory or programming operations.

17 ◀, ▶, ▲, ▼ (CURSOR) buttons

These buttons are used when controlling the cursor of the unit, DVD or other AV equipment.

(When TUNER mode is selected)

PRESET +/- buttons

This button is used to select a preset station up and down.

TUNING +/- buttons

This button is used to tune a frequency station up and down.

18 SLEEP button

This button is used for setting the sleep timer.

19 TREBLE up (▲) /down (▼) buttons

These buttons are used to adjust the tone control of high frequency sound.

20 BASS up (▲) /down (▼) buttons

These buttons are used to adjust the tone control of low frequency sound.

21 SOURCE DIRECT button

When this button is pressed, the audio signal will bypass the tone control circuit to provide the pure sound quality.

REAR PANEL

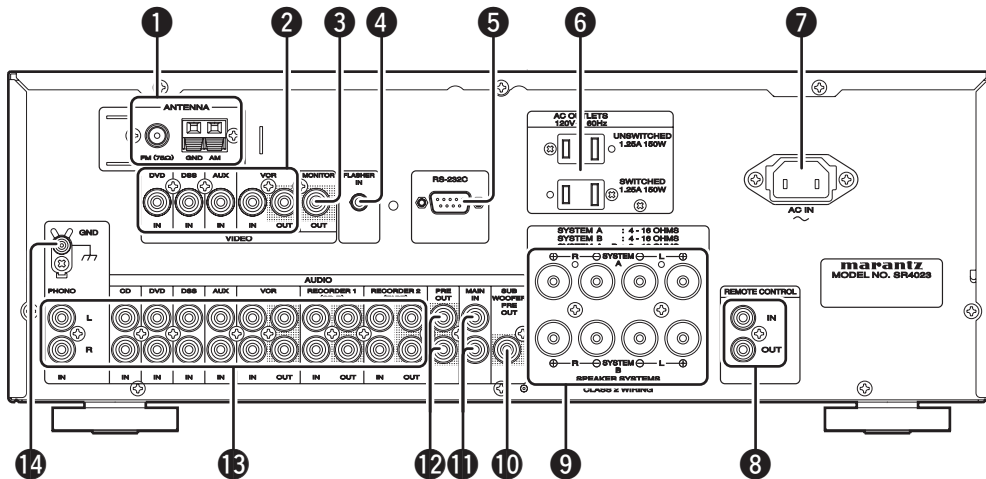

1 Antenna terminals

FM antenna terminal

For connecting the supplied FM antenna or for connecting an external FM antenna with a coaxial cable, or for connecting a cable network.

AM antenna and ground terminal

For connecting the supplied AM loop antenna. Use the terminals marked "AM" and "GND".

The supplied AM loop antenna will provide good AM reception in most areas. Position the loop antenna to the best reception.

2 VIDEO IN/OUT (AUX, DSS, DVD, VCR)

These are the video inputs and output. There are 4 video inputs and 1 video output. Connect VCR, DVD players, and other video components to the video inputs.

The 1 video output can be used to be connected to video tape recorder for making recording.

3 MONITOR output jack

Connect to the TV's video input (VIDEO IN) jack.

4 FLASHER IN (Flasher input terminal)

This terminal is to control the unit from another zone.

Connect the control signal from a Keypad, etc.

5 RS-232C

The RS-232C port is to be used in conjunction with an external controller to control the operation of the unit by using an external device.

6 AC OUTLETS

Connect the AC power cord of component such as a DVD or CD player to this outlet.

The marked SWITCHED provides power only when the SR4023 is turned on and is useful for components which you use every time you play your system.

Caution:

- In order to avoid potential turn-off thumps, anything plugged into these outlets should be powered up before the SR4023 is turned on.
- The capacity of this AC outlet is 150W. Do not connect devices that consume electricity more than the capacity of this AC outlet. If the total power consumption of the connected devices exceeds the capacity, the protection circuit shuts down the power supply.

7 AC IN

Connect to supplied an AC power cable, and connect to an AC power outlet.

This unit requires a power voltage of 120V AC only.

8 REMOTE CONTROL IN/OUT terminals

Connect to a Marantz component equipped with remote control (RC-5) terminals.

9 Speaker terminals

Connect your speaker system(s) to these terminals. There are two sets of terminals, so you can connect either A and/or B speaker systems.

10 Subwoofer Output

Connect this jack to the line level input of a powered subwoofer.

11 MAIN IN jacks

Use these jacks to connect an extension pre amplifier. (See page 13)

When not used, leave these jacks connected with the supplied connecting pins.

12 PRE OUT jacks

Use these jacks to connect an extension power amplifier. (See page 13)

When not used, leave these jacks connected with the supplied connecting pins.

13 AUDIO IN/OUT (PHONO, CD, RECORDER 1, RECORDER 2)

These are the analog audio inputs and outputs. There are 8 audio inputs (4 of which are linked to video inputs) and 3 audio outputs (1 of which is linked to video output). The audio jacks are nominally labeled for recorder1 (CD recorder) recorder2 (cassette tape deck), compact disc players, DVD players and etc.... The audio inputs and outputs require RCA-type connectors.

14 GND (ground) terminal

Connect the grounding wire from the analog turntable to this terminal.

BASIC CONNECTIONS

CONNECTING AUDIO COMPONENTS

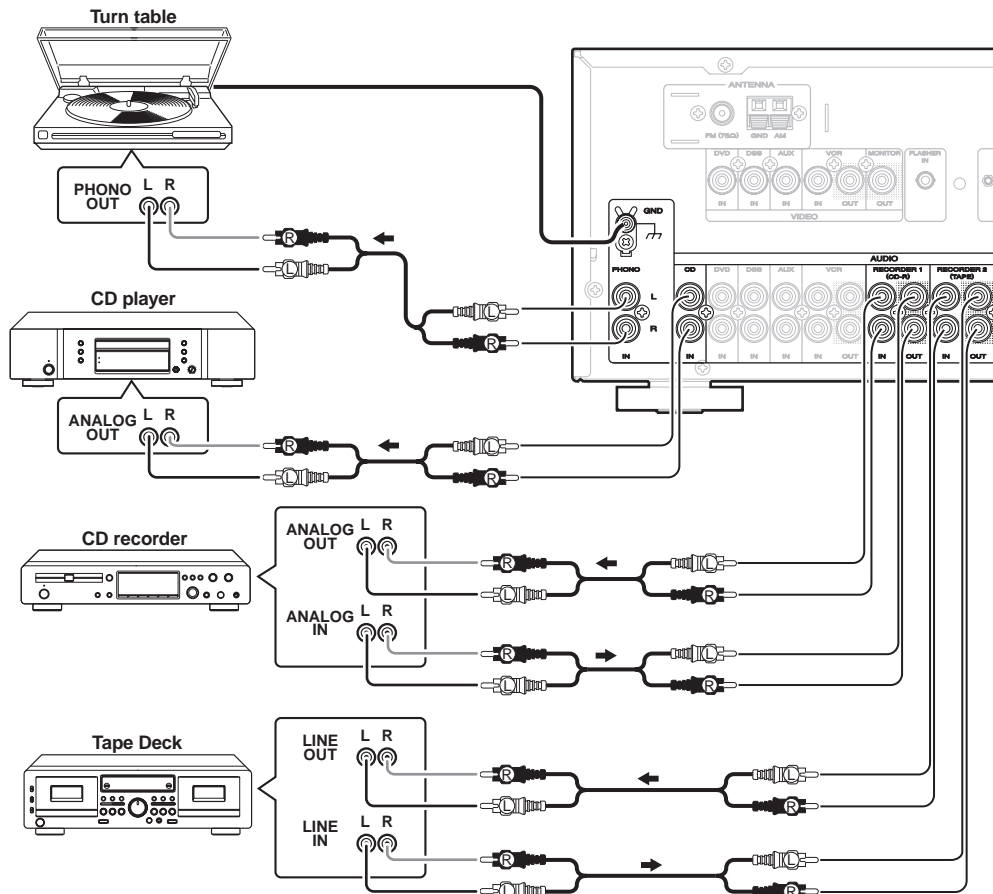

The output audio signal from the RECORDER 1 OUT jack and the RECORDER 2 OUT jack is the same signal which is currently selected.

Caution:

- Do not connect this unit and other components to mains power until all connections between components have been completed.

Notes:

- Insert all plugs and connectors securely. Incomplete connections may make noise.
- Be sure to connect the left and right channels properly. Red connectors are for the R (right) channel, and white connectors are for the L (left) channel.
- Be sure to connect input and output properly.
- Refer to the instructions for each component that is connected to this unit.
- Do not bind audio/video connection cables with power cords and speaker cables this will result in generating a hum or other noise.

CONNECTING VIDEO COMPONENTS

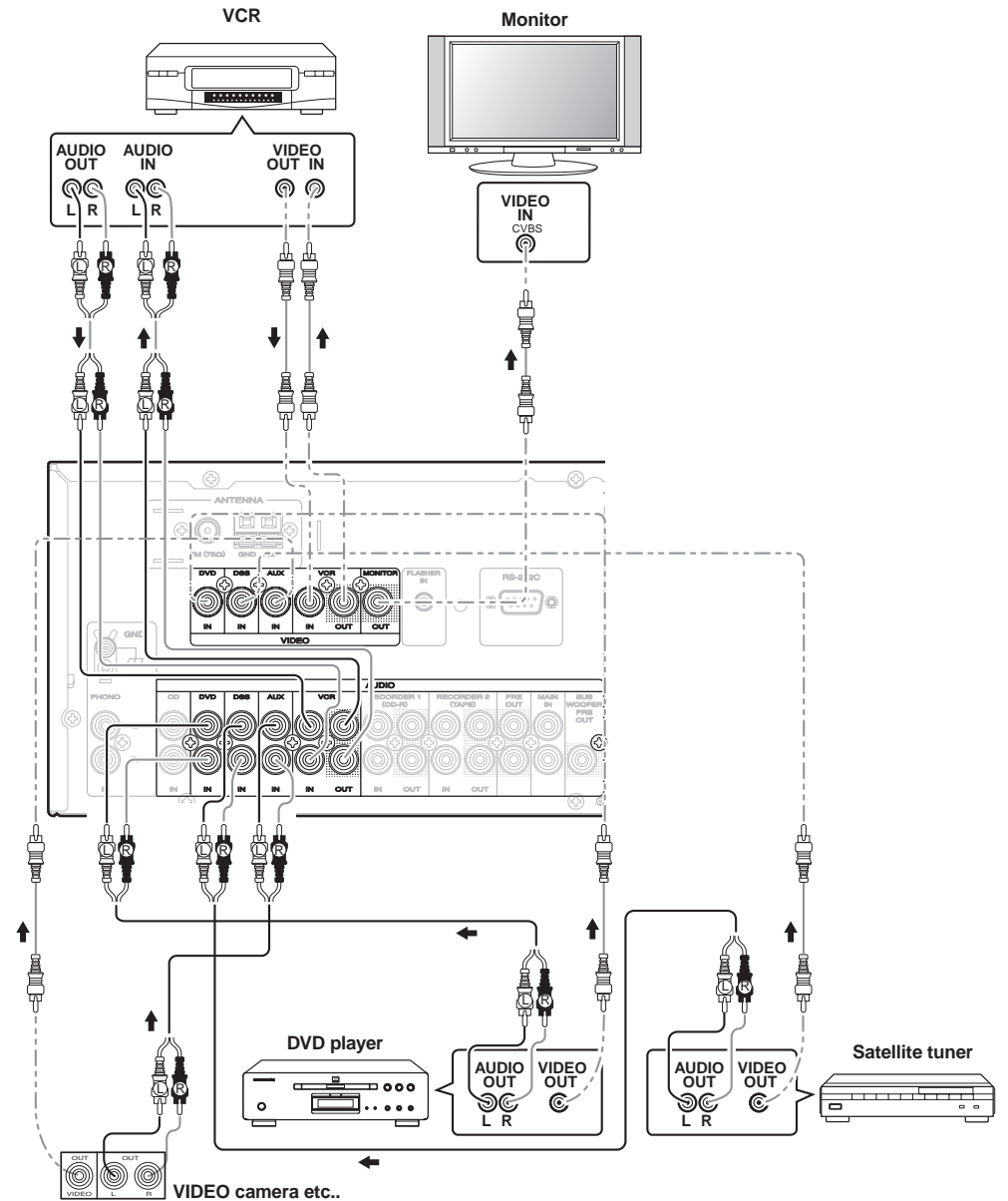

Notes:

- Insert all plugs and connectors securely. Incomplete connections will result in the generation of noise.
- Be sure to connect the left and right channels properly. Red connectors are used for the R (right) channel, and white connectors are used for L (left) channel.
- Be sure to connect input and output of video signal properly.

CONNECTING SPEAKERS

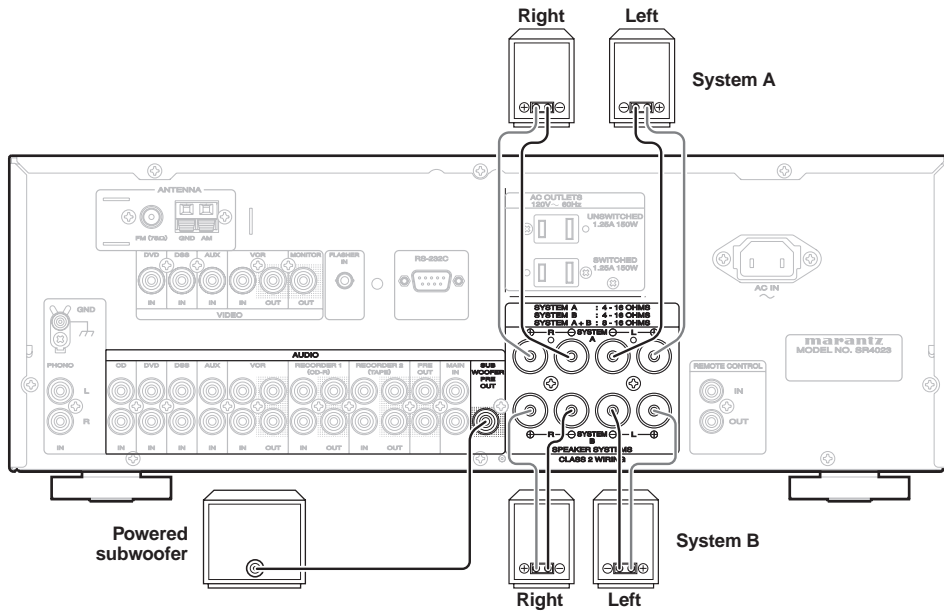

CONNECTING SPEAKER WIRE

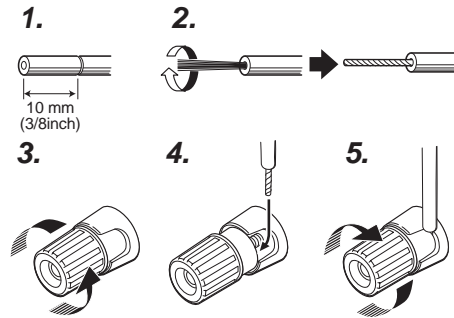

1. Strip away approx. 10 mm (3/8inch) of wire insulation.
2. Twist the bared wire ends tight, to prevent short circuits.
3. Loosen the knob by turning it counterclockwise.
4. Insert the bare part of the wire into the hole in side of each terminal.
5. Tighten the knob by turning it clockwise to secure the wire.

Caution:

- Be sure to use speakers with the specified impedance as shown on the rear panel of this unit.
- To prevent damage to circuitry, do not let the bare speaker wires touch each other and do not let them touch any metal part of this unit.
- Do not touch the speaker terminals when the power is on. It may cause you to receive an electric shocks.
- Do not connect more than one speaker cable to one speaker terminal. Doing so may damage this unit.

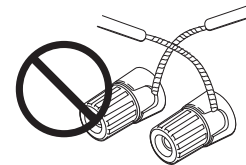

Note:

Be sure to connect the positive and negative cables for the speaker properly. If they are miss-connected, the signal phase will be reversed and the signal quality will be corrupted.

CONNECTING A SUBWOOFER

Use the PRE OUT SUBWOOFER jack to connect a powered subwoofer (power amplifier built in).

NAMES AND FUNCTIONS

BASIC CONNECTIONS

BASIC OPERATION

ADVANCED CONNECTIONS

ADVANCED OPERATION

TROUBLESHOOTING

OTHERS

CONNECTING THE ANTENNA TERMINALS

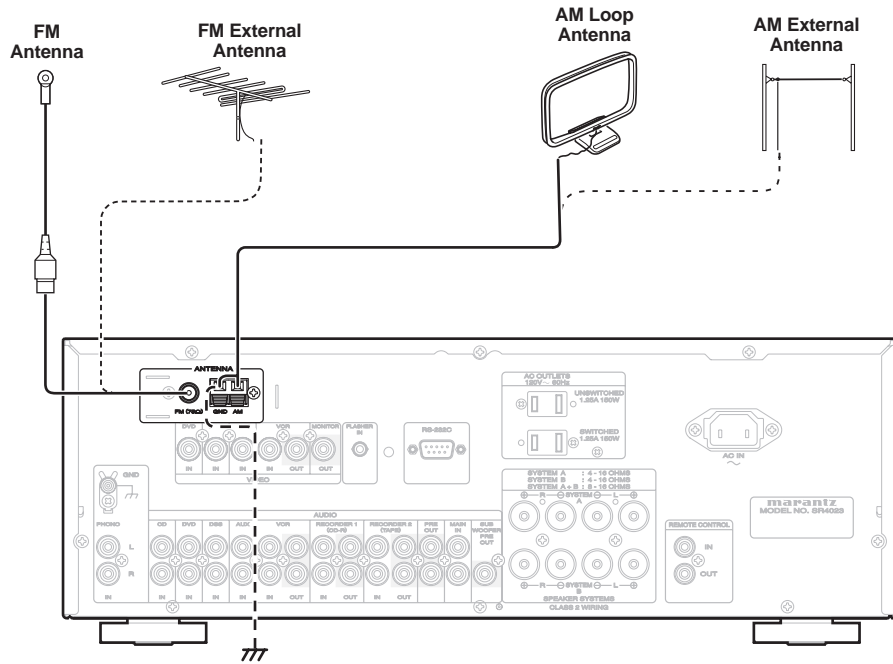

ASSEMBLING THE AM LOOP ANTENNA

1. Release the vinyl tie and take out the connection line.
3. Insert the hook at the bottom of the loop part into the slot at the base part.

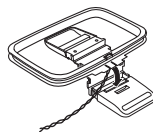
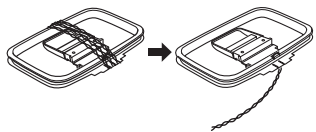

2. Bend the base part in the reverse direction.
4. Place the antenna on stable surface.

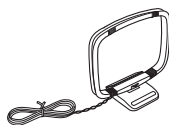

CONNECTING THE SUPPLIED ANTENNAS

Connecting the supplied FM antenna

The supplied FM antenna is for indoor use only. During use, extend the antenna and move it in various directions until the clearest signal is received. Fix it with push pins or similar implements in the position that will cause the least amount of distortion. If you experience poor reception quality, an outdoor antenna may improve the quality.

Connecting the supplied AM loop antenna

The supplied AM loop antenna is for indoor use only. Set it in the direction and position it to where you receive the clearest sound. Put it as far away as possible from the unit, televisions, speaker cables, and power cords. If you experience poor reception quality, an outdoor antenna may improve the quality.

1. Press and hold down the lever of the AM antenna terminal.
2. Insert the bare wire into the antenna terminal.
3. Release the lever.

CONNECTING AN FM OUTDOOR ANTENNA

Notes:

- Keep the antenna away from noise sources (neon signs, busy roads, etc.).
- Do not put the antenna close to power lines. Keep it well away from power lines, transformers, etc.
- To avoid the risk of lightning and electrical shock, grounding is necessary.

CONNECTING AN AM OUTDOOR ANTENNA

An outdoor antenna will be more effective if it is stretched horizontally above a window or outside.

Notes:

- Do not remove the AM loop antenna.
- To avoid the risk of lightning and electrical shock, grounding is necessary.

CONNECTING THE AC POWER CABLE

1. Plug the supplied AC power cable to the AC IN socket on the rear panel of the main unit.

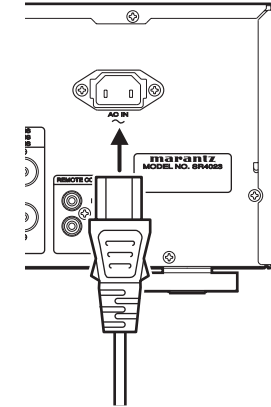

2. Plug the power cable into an AC outlet.

BASIC OPERATION

AMPLIFIER OPERATION

TURNING ON THE UNIT

1. Turn on the power of the audio equipment connected to this unit. Set the input selector on the audio equipment to this unit.
2. Connect the AC power cable to the wall outlet.
3. Press the **POWER ON/STANDBY** button on the unit. Each time you press the button, the power to the unit switches between on and standby.

To turn on the power with the remote controller, first press the AMP button and then press the **POWER ON** or **SOURCE POWER** button on the remote controller.

SELECTING AN INPUT SOURCE

Before you can listen to any input media, you must first select the input source on the SR4023.

(example : DVD)

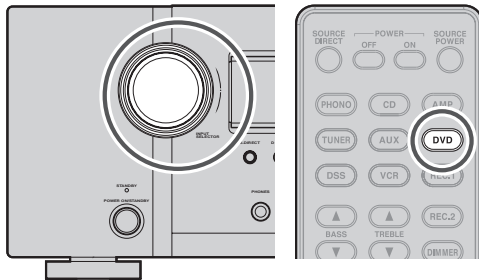

To select DVD, simply press the **DVD** button on the front panel or press the **DVD** button on the remote. After you have selected DVD, simply turn on the DVD player and play the DVD.

- The input name will appear in the display on the front-panel.
- When an audio source is selected, the last video input used remains routed to the **VCR** Output and **Monitor** Output. This permits simultaneous viewing and listening to different sources.

- When a Video source is selected, the video signal for that input will be routed to the **Monitor Output** jack and will be viewable on a TV monitor connected to the SR4023.

ADJUSTING THE MAIN VOLUME

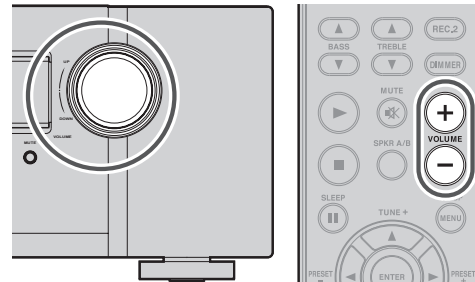

Adjust the volume to a comfortable level using the **VOLUME** control knob on the front panel or **VOLUME ▲ / ▼** buttons on the remote.

To increase the volume, turn the **VOLUME** knob clockwise or press **VOLUME ▲** button on the remote, to decrease the volume, turn counterclockwise or press **VOLUME ▼** button on the remote.

Note:

The volume can be adjusted within the range of -90 (∞) to 0 dB, in steps of 1 dB.

ADJUSTING THE TONE (BASS & TREBLE)



During a listening session you may wish to adjust the Bass and Treble Control to suit your listening tastes or room acoustics.

(Using the remote control unit)

To adjust the bass effect, press **BASS ▲** or **BASS ▼** on the remote.

To adjust the treble effect, press **TREBLE ▲** or **TREBLE ▼** on the remote.

Note:

When Source Direct mode is set, tone control is disable.

TEMPORARILY TURNING OFF THE SOUND

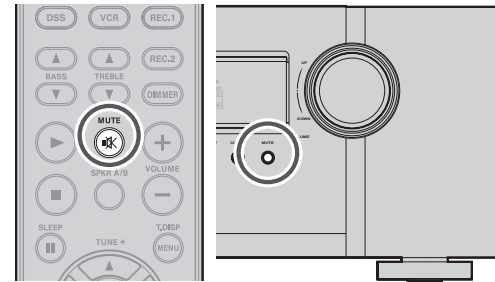

To temporarily silence all speaker outputs such as when interrupted by a phone call, press the **MUTE** button on the front panel or **MUTE** button on the remote.

This will interrupt the output to all speakers and the head-phone jack, but it will not affect any recording or dubbing that may be in progress.

When the system is muted, the display will show **"MUTE ON"**.

Press the **MUTE** button again to return to normal operation.

LISTENING THROUGH HEADPHONES

This jack may be used to listen to the unit's output through a pair of headphones. Be certain that the headphones have a standard 1/4" stereo phono plug. (Note that the speakers will automatically be turned off when the headphone jack is in use.)

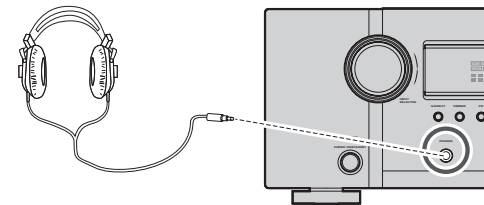

TUNER OPERATION

LISTENING TO THE TUNER

Frequency scan step for AM is selectable. Default setup is 10 kHz step, if your country's standard is 9 kHz step, Press **BAND** button on the remote controller more than 6 seconds. Scan step will change.

Note:

Preset memory for the tuner will clear by changing this setup.

AUTO TUNING

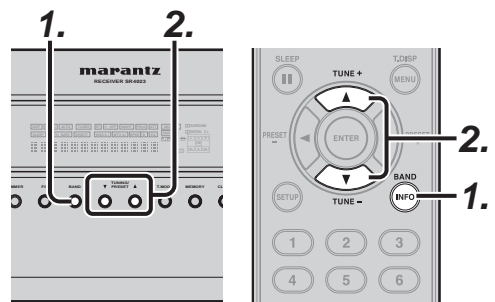

(Using the unit)

1. To select tuner and desired band (FM or AM), press the **BAND** button on the front panel.
2. Press the **TUNING/PRESET** ▲ or ▼ buttons on the front panel for more than 1 second to start the auto tuning function.
3. Automatic searching begins then stops when a station is tuned in.

(Using the remote controller)

1. To select tuner and desired band (FM or AM), press the **BAND** button on the remote controller.
2. Press the **TUNE +** or – (▲ or ▼) for more than 1 second on the remote controller.
3. Automatic searching begins then stops when a station is tuned in.

If tuning does not stop at the desired station, use to the "Manual tuning" operation.

MANUAL TUNING

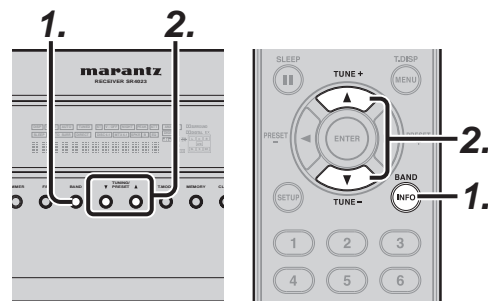

(Using the unit)

1. To select tuner and desired band (FM or AM), press the **BAND** button on the front panel.
2. Press the **TUNING/PRESET** ▲ or ▼ buttons on the front panel to select the desired station.

(Using the remote controller)

1. To select tuner and desired band (FM or AM), press the **BAND** button on the remote controller.
2. Press the **TUNE +** or – (▲ or ▼) on the remote controller to tune in the desired station.

DIRECT FREQUENCY CALL

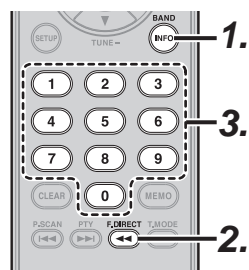

1. To select tuner and desired band (FM or AM), press the **BAND** button on the remote controller.
2. Press the **F.DIRECT** on the remote controller, display will show "FREQ ----".
3. Input your desired station's frequency with the **numeric** buttons on the remote controller.
4. The desired station will automatically be tuned.

(FM) TUNING MODE (AUTO STEREO OR MONO)

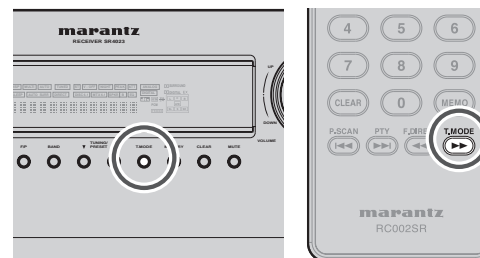

When in the auto stereo mode, **AUTO** indicator will be illuminated on the display.

The "ST" indicator is illuminated when a stereo broadcast is tuned in.

At open frequencies, the noise is muted and the "TUNED" and "ST" indicators are not illuminated.

If the signal is weak, it may be difficult to tune into the station in stereo. In such a case, press the **T-MODE** button on the front panel or remote controller.

"AUTO" indicator is not illuminated, if FM stereo broadcasts are received in monaural and the "ST" indicator is not illuminated.

To return to auto stereo mode, press the **T-MODE** button or press **T-MODE** button on the remote controller again. **AUTO** indicator is illuminated on the display.

ADVANCED CONNECTIONS

CONNECTING MAIN IN JACKS

If you use a pre amplifier, connect it as shown below, and then you can use this unit as a power amplifier. For details on operations of the pre amplifier, refer to the instruction manual supplied with the pre amplifier to be used.

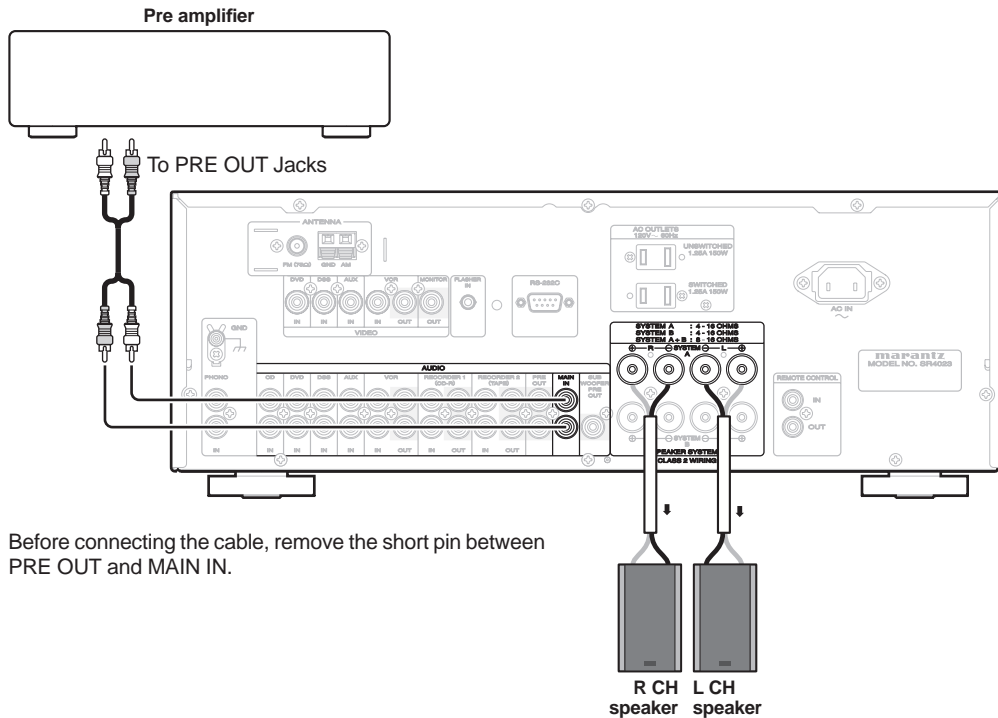

Note:

If you use this unit as a power amplifier, the preamplifier section does not function, and the INPUT SELECTOR, VOLUME, BASS and TREBLE are disabled.

CONNECTING PRE OUT JACKS

If you use a power amplifier, connect it as shown below, and then you can use this unit as a pre amplifier. To connect speaker systems, refer to the instruction manual supplied with the power amplifier to be used.

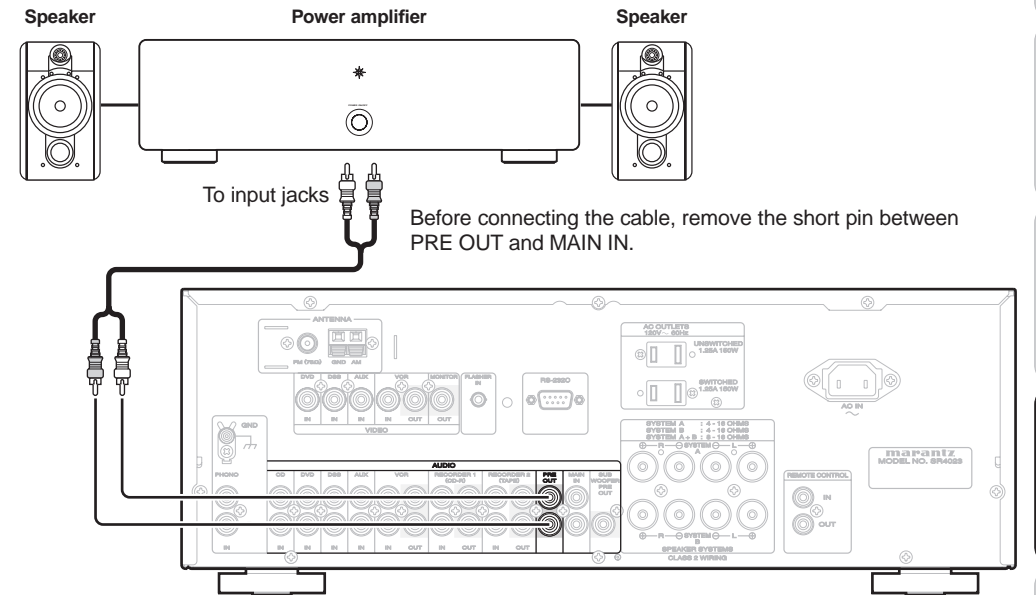

NAMES AND FUNCTIONS

BASIC CONNECTIONS

BASIC OPERATION

ADVANCED CONNECTIONS

ADVANCED OPERATION

TROUBLESHOOTING

OTHERS

CONNECTING THE REMOTE CONTROL JACKS

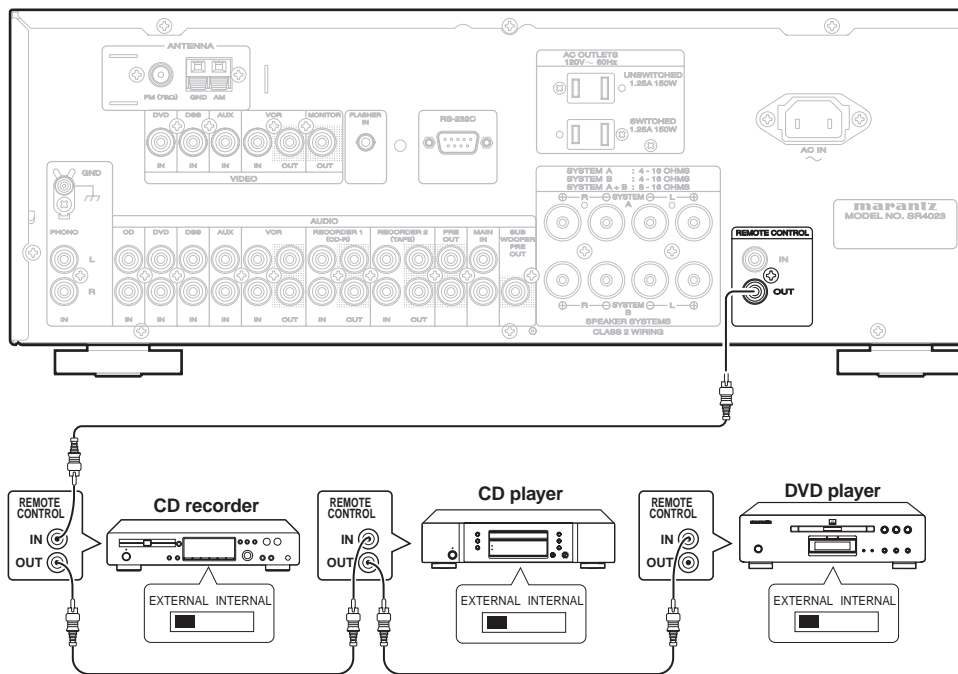

① You can control other Marantz products through this unit with the remote control by connecting the REMOTE CONTROL terminals on each unit. The signal transmitted from the remote control is received by the remote sensor on this unit. Then the signal is sent to the connected device through this terminal. Therefore you only need to aim the remote at one unit. Also, if a Marantz power amplifier (some models excluded) is connected to one of these terminals, the power amplifier's, power switch is synchronized with this unit's power switch.

Set the REMOTE CONTROL SWITCH on the units, other than the main unit to EXT.(EXTERNAL) for this feature.

② Whenever external infrared sensors or similar devices are connected to RC-5 IN of the SR4023, be sure to always disable operation of the infrared sensor on the main unit by using the following procedure.

1. Hold down the **S-DIRECT** button and **BAND** button on the front panel at the same time for 3 seconds.
2. The setting "IR=ENABLE" is shown on the FL DISPLAY.
3. Press **TUNING/PRESET** ▲ or ▼ button to change this to "IR=DISABLE".
4. Press the **MUTE** button. Once this setting is made, the infrared sensor on the main unit is disabled.

Note:

Be sure to set to "IR=ENABLE" when external infrared sensors or similar devices are not connected. Otherwise, the main unit will be unable to receive remote control commands.

5. To restore the original setting, perform steps 1 to 4 to set to "IR=ENABLE".

ADVANCED OPERATION

AMPLIFIER OPERATION

USING THE SLEEP TIMER



To program this unit for automatic standby, press the **SLEEP** button on the remote controller.

Each press of the button will increase the time before shut down in the following sequence.

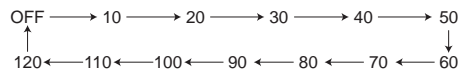

The sleep time will be shown for a few seconds in the display on the front panel, and it will count down until the time has elapsed.

When the programmed sleep time has elapsed, the unit will automatically turn off.

Note that the **SLEEP** indicator on the display will illuminate when the Sleep function is programmed.

To cancel the Sleep function, press the **SLEEP** button until the display shows "SLEEP OFF" and the **SLEEP** indicator will disappear.

RECORDING A SOURCE

In normal operation, the audio or video source selected for listening through the SR4023 is sent to the record outputs.

This means that any program you are watching or listening to may be recorded simply by placing machines connected to the outputs for **RECORDER1 OUT**, **RECORDER2 OUT**, and **VCR OUT** in the record mode.

To record the input source signal you are currently watching or listening to

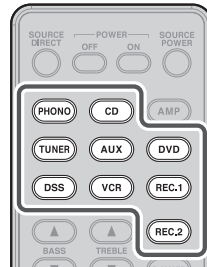
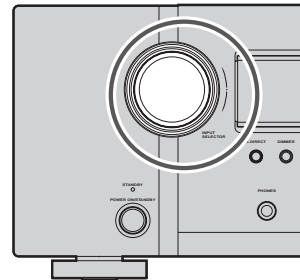

1. Select the input source to record by pressing the corresponding **input selector** button.
The input source is now selected and you may watch or listen to it as desired.
2. The currently selected input source signal is output to the **RECORDER 1 OUT**, **RECORDER 2 OUT**, and **VCR OUT** outputs for recording.
3. Start recording to the recording component as desired.

Recording the video from one source and the audio from another

You can add the sound from one source to the video of another source to make your own video recordings.

Below is an example of recording the sound from a compact disc player connected to **CD IN** and the video from a video camera connected to **AUX IN** in video cassette recorder connected to the **VCR OUT** jack.

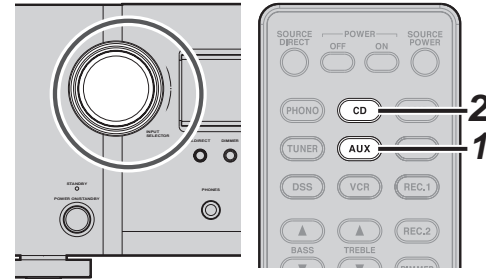

1. Press the **AUX** input source button to set video output.
2. Press the **CD** input source button to set audio output.
3. Now "CD" has been selected as the audio input source and "AUX" as the video input source.

Notes:

- If you change the input source during recording, you will record the signals from the newly selected input source.
- The setting of **BASS**, **TREBLE**, **VOLUME**, **MUTE** does not affect the recorded material.
- A given input source does not output on the same **OUT** channel (For example, the signal input from **VCR IN** is not output on **VCR OUT**).
- If you playback a video source that uses scrambled or encoded signals to prevent it from being dubbed, the picture itself may be disturbed due to those signals.

TUNER OPERATION (PRESET MEMORY)

With this unit you can preset up to 50 FM/AM stations in any order. For each station, you can memorize the frequency and reception mode if desired.

AUTO PRESET MEMORY

This function automatically scans the FM and AM band and enters all stations with proper signal strength into the memory.

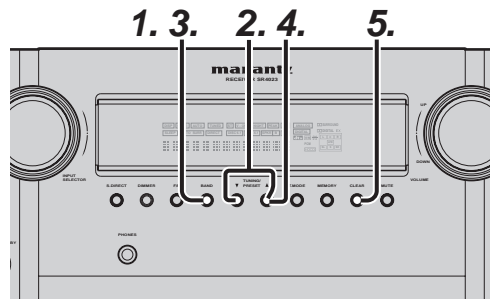

- To select FM, press the **BAND** button on the front panel.
- While pressing the **MEMO** button, press the **TUNING ▲** button. "AUTO PRESET" will appear on the display, and scanning starts from the lowest frequency.
- Each time the tuner finds a station, scanning will pause and the station will be played for five seconds. During this time, the following operations are possible. The band can be changed by the **BAND** button.
- If no button is pressed during this period, the current station is memorized in location Preset 01. If you wish to skip the current station, press the **▲** cursor button during this period, this station is skipped and auto presetting continues.
- Operation stops automatically when all 50 preset memory positions are filled or when auto scanning attains the highest end of all bands. If you desire to stop the auto preset memory at anytime, press the **CLEAR** button.

Note:

It is possible that existing preset memory positions will be overwritten.

MANUAL PRESET MEMORY

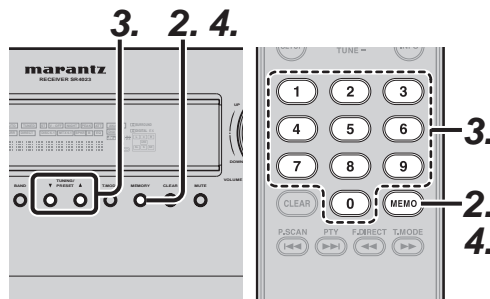

(Using the unit)

- Tune into the radio station you desire (Refer to the "MANUAL TUNING" or "AUTO TUNING" section).
- Press the **MEMORY** button on the front panel. "– –" (preset number) starts blinking on the display.
- Select the preset number by pressing the **TUNING ▲** or **▼** buttons, while this indicator is still blinking (approx. 5 seconds)
- Press the **MEMORY** button again to enter. The display stops blinking. The station is now stored in the specified preset memory location.

(Using the remote controller)

- Tune into the radio station you desire (Refer to the "MANUAL TUNING" or "AUTO TUNING" section).
- Press the **MEMO** button on the remote controller. "– –" (preset number) starts blinking on the display.
- Enter the desired preset number by pressing the **numeric** buttons.

Note:

When entering a single digit number (2 for example), either input "02" or just input "2" and wait for a few seconds.

RECALLING A PRESET STATION

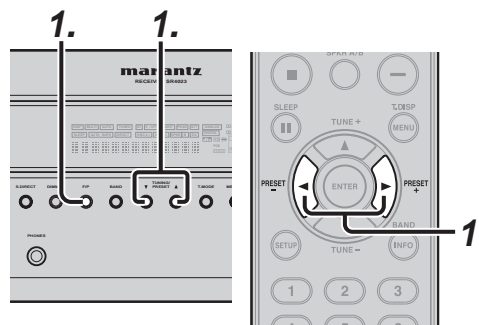

(Using the unit)

- Select the desired preset station by pressing the **F/P** and **TUNING ▲** or **▼** button on the front panel

(Using the remote controller)

- Press the **PRESET +** or **–** buttons to select the desired preset station, or input your desired preset channel with the **numeric** buttons on the remote controller.

PRESET SCAN

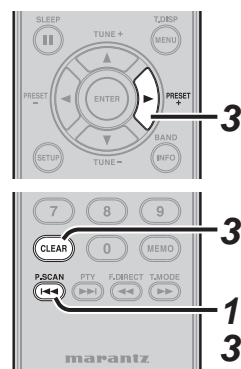

(Using the remote controller)

- Press the **P.SCAN** on the remote controller. "PRESET SCAN" appears on the display and then the preset station with the lowest preset number is recalled first.
- Preset stations are recalled in sequence (No.1 → No.2 → etc.) for 5 seconds each. No stored preset number will be skipped.
- You can fast forward the preset stations by pressing the **PRESET +** continuously. When the desired preset station is received, cancel the preset scan operation by pressing the **CLEAR** button or **P.SCAN** on the remote controller.

CLEARING STORED PRESET STATIONS

You can remove preset stations from the memory using the following procedure.

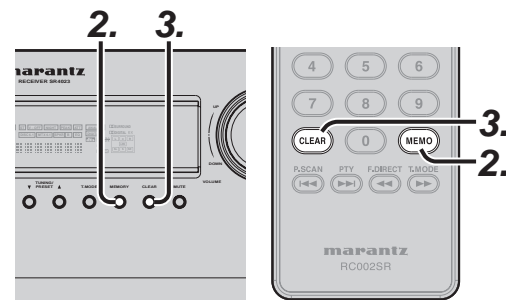

- Recall the preset number to be cleared with the method described in "Recalling" a preset station.
- Press the **MEMORY** button on the front panel or press the **MEMO** button on the remote controller.
- The stored preset number blinks in the display for 5 seconds. While blinking, press the **CLEAR** button on the front panel or the remote controller.
- "xx CLEAR" appears on the display to indicate that the specified preset number has been cleared.

Note:

To clear all stored preset stations, press and hold the **CLEAR** and the **F/P** buttons on the front panel for two seconds.

SORTING PRESET STATIONS

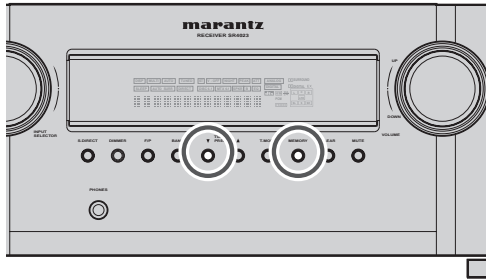

If you have stations memorized, and there is a gap in the sequential order:

I.e. the stations are stored as follows

- 1) 87.5 MHz
- 2) 93.1 MHz
- 3) 94.7 MHz
- 10) 105.9 MHz

Since there are no stations programmed for presets 4-9, you can have preset 10 become preset 4.

To sort the numbers, press the **TUNING ▼** button while pressing the **MEMORY** button.

"PRESET SORT" will appear on the display and sorting will be done.

NAME INPUT OF THE PRESET STATION.

This function allows the name of each preset channel to be entered using alphanumeric characters.

Before name inputting, you need to store preset stations with the preset memory operation.

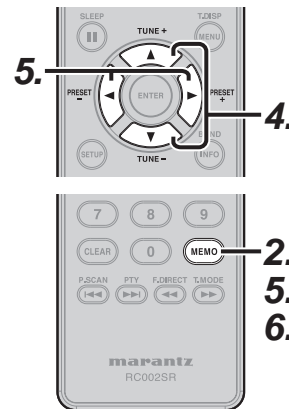
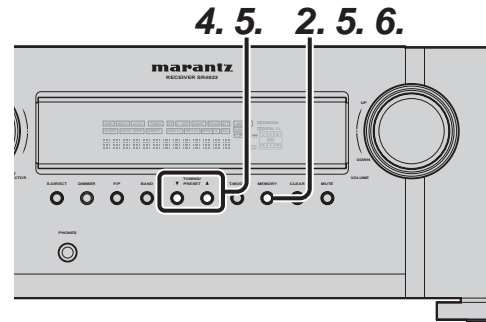

1. Recall the preset number to be inputted name with the method described in "Recalling" a preset station.
2. Press the **MEMORY** button on the front panel or press the **MEMO** button on the remote controller for more than 3 seconds.
3. The left most column of the station name indicator flashes, indicating the character entry ready status.

4. When you press the **TUNING ▲** or **▼** buttons on the front panel or the **TUNING +** or **-** buttons on the remote controller, alphabetic and numeric characters will be displayed in the following order:

A → B → C ... Z → 1 → 2 → 3 0 → - → +
→ / → (Blank) → A

UP →

← DOWN

5. After selecting the first character to be entered, press the **MEMORY** button or press the **MEMO** button on the remote controller.

The entry in this column is fixed and the next column starts to flash. Fill the next column the same way.

To move back and forth between the characters, press the **F/P** button and press the **TUNING ▲** or **▼** buttons or press **TUNING +** or **-** buttons on the remote controller.

Note:

Unused columns should be filled by entering blanks.

6. To save the name, press the **MEMORY** button on the front panel or remote controller for more than 2 seconds.

Ten keypad	Press, press again, press again, etc.
1	A → B → C → 1 → A
2	D → E → F → 2 → D
3	G → H → I → 3 → G
4	J → K → L → 4 → J
5	M → N → O → 5 → M
6	P → Q → R → 6 → P
7	S → T → U → 7 → S
8	V → W → X → 8 → V
9	Y → Z → space → 9 → Y
0	- → + → / → 0 → -

REMOTE CONTROLLER OPERATION

THE CONTROLLABLE FUNCTION TABLE

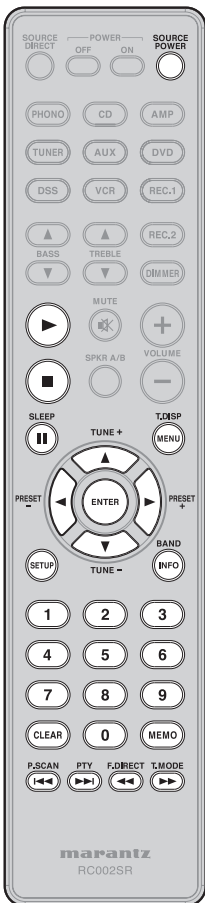

BUTTON NAME	FUNCTION		
	CD	DVD	TAPE
SOURCE POWER	POWER ON / Standby	POWER ON / Standby	POWER ON / Standby
▶	Starts playback	Starts playback	Starts playback
■	Stops playback	Stops playback	Stops playback
SLEEP / ⏸	Pauses a disc that's playing	Pauses a disc that's playing	Pauses a disc that's playing
T.DISP / MENU	Not for use	Displays a DVD disc menu	Not for use
(UP) / TUNE+	Not for use	Move the cursor upward	Not for use
(DOWN) / TUNE-	Not for use	Move the cursor downward	Not for use
(LEFT) / PRESET-	Not for use	Move the cursor leftward	Not for use
(RIGHT) / PRESET+	Not for use	Move the cursor rightward	Not for use
ENTER	Not for use	Selects the current menu option	Not for use
SETUP	Not for use	Not for use	Go to the setup Menu
BAND / INFO	Not for use	Displays the disc playback information	Not for use
0-9	Inputs the numeric	Inputs the numeric	Not for use
CLEAR	Not for use	Not for use	Resets counter
MEMO	Not for use	Not for use	Not for use
P.SCAN / ⏮	Skips to the start of the current track	Skips to the start of the current track or chapter	Skips to the start of the current track
PTY / ⏭	Skips to the next track	Skips to the next track or chapter	Skips to the next track
F.DIRECT / ⏪	Fast rewind the playing track	Fast rewind the playing chapter	Fast rewind the playing track
T.MODE / ⏩	Fast forward the playing track	Fast forward the playing chapter	Fast forward the playing track

REMOTE CONTROL CODE SETTING

The remote control unit contains 3 sets of remote control codes, and it can be used to control up to 3 receivers in one location. To control a second or third receiver, select the remote control code as explained below. The selected receiver can be operated from the remote control.

- When the unit is shipped from the factory, the main unit and remote control are set to RECEIVER1.

1. RECEIVER2

To set the remote control to RECEIVER2, hold down both the **AMP** button and **2** number button on the remote control for at least five seconds.

RECEIVER3

To set the remote control to RECEIVER3, hold down both the **AMP** button and **3** number button on the remote control for at least five seconds.

- Also set the main unit's remote control setting to the same setting as the remote controller. To change the main unit's remote control setting, hold down **AMP** and press the **INFO** buttons on the remote controller; the remote control setting ("RECEIVER 1," "RECEIVER 2" or "RECEIVER 3") will be displayed in the display window on the main unit and the main unit setting will be changed to the same setting as that of the remote controller.

Note:

To set the remote control back to RECEIVER1, hold down both the **AMP** button and **1** number button on the remote control for at least five seconds.

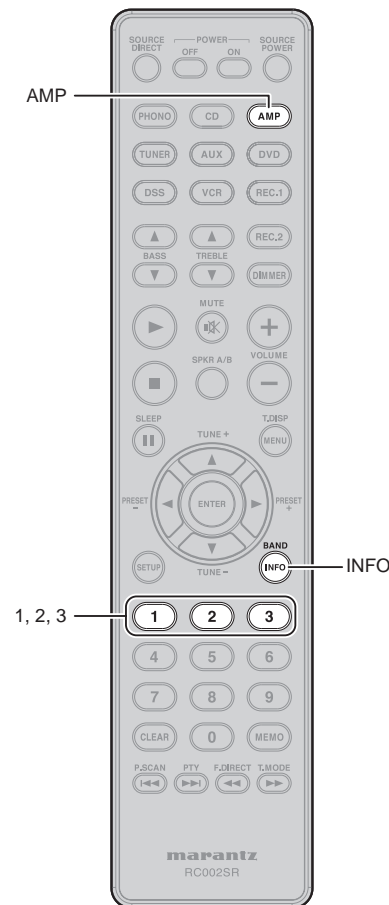

TROUBLESHOOTING

In case of trouble, check the following before calling for service:

1. Are the connections made properly ?
2. Are you operating the unit properly following the user's guide ?
3. Are the power amplifiers and speaker working properly ?

If the unit does not operate properly, check items shown in the following table.

If your trouble cannot be recovered with the remedy actions listed in the following table, malfunction of the internal circuitry is suspected; immediately unplug the power cable and contact your dealer, nearest Marantz authorized dealer or the Marantz Service Center in your country.

SYMPTOM	CAUSE	REMEDY
SR4023 cannot be turned up.	The power plug is not connected.	Connect the power plug to the outlet.
No sound and picture are output even when power is on.	Mute is on.	Cancel mute using the remote control unit.
	The input cable is not connected correctly.	See the connection diagram and connect the cables correctly.
	The master volume control is turned all the way down.	Adjust the master volume.
	The function selector position is wrong.	Select correct position.
No speaker output.	The headphones are connected to the headphone jack.	Disconnect the headphones. (Speakers will not output sound when headphones are connected.)
Incorrect Audio or Video for selected source.	Input cable connected incorrectly.	Connect the cable correctly by referring to the connection diagram.
FM or AM reception fails.	Antenna connection is incomplete.	Correctly connect the indoor FM and AM antennas to FM and AM antenna outlets.
Noise is heard during AM reception.	Reception is affected by other electrical fields.	Try changing location where the AM indoor antenna is set up.
Noise is heard during FM reception.	The radio waves from the broadcasting station are weak.	Install an FM outdoor antenna.
Cannot get programmed station when the PRESET button is pressed.	Preset data has been erased.	Disconnecting power plug for long periods of time will erase preset data. If that happens, input the preset data again.
Control with the remote control unit fails.	Batteries are consumed.	Replace all the batteries with new ones.
	Remote controller's function-key setting is wrong.	Select different position from which equipment will be controlled.
	The distance between this unit and the remote commander is too far.	Move closer to this unit.
	Something is blocking unit and the remote commander.	Remove offending object.
	The main unit and remote controller are set to use different remote control codes.	Set the main unit and remote controller to use the same remote control code.

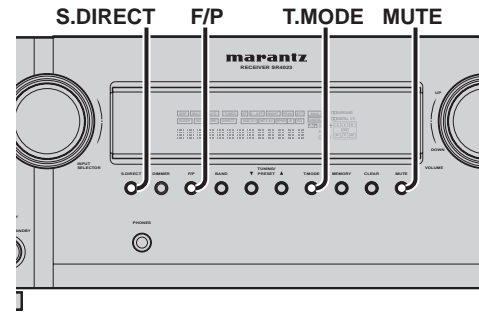

FRONT KEY (BUTTON) LOCK OF THE UNIT

If the **F/P** and **T.MODE** buttons on the front panel are both pressed at the same time for three seconds or more, all the buttons on the front panel, (excluding the **POWER ON/STANDBY** button), as well as the **INPUT SELECTOR** knob and **VOLUME** knob, will become locked. "F-KEY LOCK!" will appear in the display.

Release the lock by pressing the same two keys again at the same time for three seconds or more. "F-KEY UNLOCK" will appear in the display, and the keys will unlock.

GENERAL MALFUNCTION

If the equipment malfunctions, this may be because an electrostatic discharge or AC line interference has corrupted the information in the equipment memory circuits. Therefore:

- disconnect the plug from the AC line supply
- after waiting at least three minutes, reconnect the plug to the AC line supply
- re-attempt to operate the equipment

Memory backup

- In case a power outage occurs or the power cord is accidentally unplugged, this unit is equipped with a backup function to prevent memory data such as the preset memory from being erased.

HOW TO RESET THE UNIT

Should the operation or display seem to be abnormal, reset the unit with the following procedure.

The SR4023 is turned on, press and hold the **MUTE** and **S.DIRECT** buttons simultaneously for 3 seconds or more.

Remember that the procedure will reset the settings of the function selector, TUNER PRESET etc., to their initial settings.

OTHERS

TECHNICAL SPECIFICATIONS

FM TUNER SECTION

Frequency Range 87.5 – 108.0 MHz
 Usable Sensitivity IHF 1.8 µV/16.4 dB
 Signal to Noise Ratio Mono/Stereo 75/70 dB
 Distortion..... Mono/Stereo 0.2/0.3%
 Stereo Separation..... 1 kHz 45 dB
 A.C.S ±400 kHz 60 dB
 Image Rejection..... 98 MHz 70 dB
 Tuner Output Level 1 kHz, ±75 kHz Dev 800 mV

AM TUNER SECTION

Frequency Range 520 – 1710 kHz
 Usable Sensitivity Loop 400 µV
 Signal to Noise Ratio 50 dB
 Distortion..... 400 Hz, 30% Mod. 0.5%
 Selectivity..... ±20 kHz 70 dB

AUDIO SECTION

Rated Power 20 Hz – 20 kHz 8 ohms 80 W/Ch
 20 Hz – 20 kHz 4 ohms 100 W/Ch
 THD 20 Hz – 20 kHz 8 ohms 0.08%
 Input Sensitivity/Impedance
 Linear 200 mV/47 kohms
 Signal to Noise Ratio (IHF A)
 Linear 95 dB

GENERAL

Power Requirement AC 120 V 60 Hz
 Power Consumption 220 W
 Weight 9.0 Kg

ACCESSORIES

Remote Control Unit 1
 AAA-size batteries 2
 FM Antenna 1
 AM Loop Antenna 1
 AC Power Cable 1
 User Guide..... 1

Specifications subject to change without prior notice.

DIMENSIONS

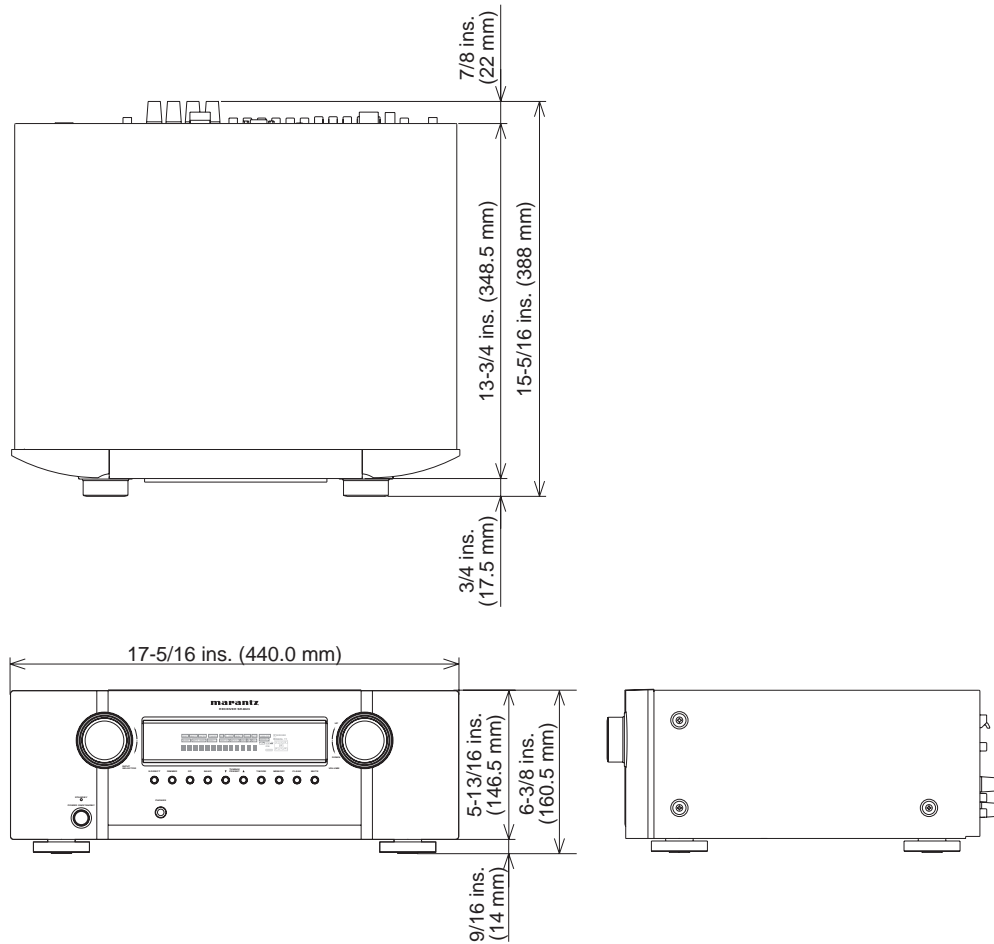

CLEANING OF EQUIPMENT EXTERNAL SURFACES

The exterior finish of your unit will last indefinitely with proper care and cleaning. Never use scouring pads, steel wool, scouring powders or harsh chemical agents (e.g., lye solution), alcohol, thinner, benzene, insecticide or other volatile substances as these will mar the finish of the equipment. Likewise, never use cloths containing chemical substances. If the equipment get dirty, wipe the external surfaces with a soft, lint-free cloth.

If the equipment becomes heavily soiled:

- dilute some washing up liquid in water, in a ratio of one part detergent to six parts water.
- dip a soft, lint free in the solution and wring the it is damp.
- wipe the equipment with the damp cloth.
- dry the equipment by wiping it with a dry cloth.



REPAIRS

Only the most competent and qualified service technicians should be allowed to service the factory-trained warranty station personnel have the knowledge and special facilities needed for repair and calibration of this precision equipment. After the warranty period has expired, repairs will be performed for a charge if the equipment can be returned to normal operation.

In the event of difficulty, refer to your dealer or write directly to the nearest location to you that is listed on the Marantz Authorized Service Station list. If writing, please include the model and serial number of the equipment together with a full description of what you think is abnormal about the equipment's behaviour.

www.marantz.com

You can find your nearest authorized distributor or dealer on our website.

marantz[®] is a registered trademark.

