

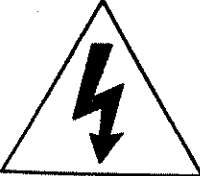

# **marantz®**

## **Model SR780 User Guide**

---

**Audio/Video Receiver**

	<b>CAUTION</b> <b>RISK OF ELECTRIC SHOCK</b> <b>DO NOT OPEN</b>	
<p><b>CAUTION: TO REDUCE THE RISK OF ELECTRIC SHOCK,</b></p> <p><b>DO NOT REMOVE COVER (OR BACK)</b></p> <p><b>NO USER-SERVICEABLE PARTS INSIDE</b></p> <p><b>REFER SERVICING TO QUALIFIED SERVICE PERSONNEL</b></p>		

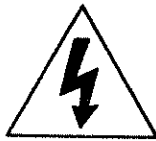

The lightning flash with arrowhead symbol, within an equilateral triangle, is intended to alert the user to the presence of uninsulated "dangerous voltage" within the product's enclosure that may be of sufficient magnitude to constitute a risk of electric shock to persons.



The exclamation point within an equilateral triangle is intended to alert the user to the presence of important operating and maintenance (servicing) instructions in the literature accompanying the appliance.

## WARNING

**TO REDUCE THE RISK OF FIRE OR ELECTRIC SHOCK,  
DO NOT EXPOSE THIS APPLIANCE TO RAIN OR MOISTURE.**

**CAUTION: TO PREVENT ELECTRIC SHOCK, MATCH WIDE BLADE  
OF PLUG TO WIDE SLOT, FULLY INSERT.**

**ATTENTION: POUR ÉVITER LES CHOCS ÉLECTRIQUES,  
INTRODUIRE LA LAME LA PLUS LARGE DE LA FICHE DANS LA  
BORNE CORRESPONDANTE DE LA PRISE ET POUSSER  
JUSQU'AU FOND.**

### NOTE TO CATV SYSTEM INSTALLER:

This reminder is provided to call the CATV (Cable-TV) system installer's attention to Article 820-40 of the NEC, that provides guidelines for proper grounding and, in particular, specified that the cable ground shall be connected to the grounding system of the building, as close to the point of cable entry as practical.

### NOTE:

This equipment has been tested and found to comply with the limits for a Class B digital device, pursuant to Part 15 of the FCC Rules. These limits are designed to provide reasonable protection against harmful interference in a residential installation. This equipment generates, uses and can radiate radio frequency energy and, if not installed and used in accordance with the instructions, may cause harmful interference to radio communications. However, there is no guarantee that interference will not occur in a particular installation. If this equipment does cause harmful interference to radio or television reception, which can be determined by tuning the equipment off and on, the user is

encouraged to try to correct the interference by one or more of the following measures:

- Reorient or relocate the receiving antenna.
- Increase the separation between the equipment and receiver.
- Connect the equipment into an outlet on a circuit different from that to which the receiver is connected.
- Consult the dealer or an experienced radio/TV technician for help.

### NOTE:

Changes or modifications may cause this unit to fail to comply with Part 15 of the FCC Rules and may void the user's authority to operate the equipment.

# IMPORTANT SAFETY INSTRUCTIONS

## READ BEFORE OPERATING EQUIPMENT

This product was designed and manufactured to meet strict quality and safety standards. There are, however, some installation and operation precautions which you should be particularly aware of.

1. **Read Instructions** - All the safety and operating instructions should be read before the appliance is operated.
2. **Retain Instructions**-The safety and operating instructions should be retained for future reference.
3. **Heed Warnings**-All warnings on the appliance and in the operating instructions should be adhered to.
4. **Follow Instructions**-All operating and use instructions should be followed.
5. **Cleaning**-Unplug this video product from the wall outlet before cleaning. Do not use liquid cleaners or aerosol cleaners. Use a damp cloth for cleaning.
6. **Attachments**-Do not use attachments not recommended by the video product manufacturer as they may cause hazards.
7. **Water and Moisture**-Do not use this video product near water-for example, near a bath tub, wash bowl, kitchen sink, or laundry tub, in a wet basement, or near a swimming pool, and the like.
8. **Accessories**-Do not place this video product on an unstable cart, stand, tripod, bracket, or table. The video product may fall, causing serious injury to a child or adult, and serious damage to the appliance. Use only with a cart, stand, tripod, bracket, or table recommended by the manufacturer, or sold with the video product. Any mounting of the appliance should follow the manufacturer's instructions, and should use a mounting accessory recommended by the manufacturer.
9. **Ventilation**-Slots and openings in the cabinet are provided for ventilation and to ensure reliable operation of the video product and to protect it from overheating, and these openings must not be blocked or covered. The openings should never be blocked by placing the video product on a bed, sofa, rug, or other similar surface. This video product should never be placed near or over a radiator or heat register. This video product should not be placed in a built-in installation such as a bookcase or rack unless proper ventilation is provided or the manufacturer's instructions have been adhered to.
10. **Power Sources**-This video product should be operated only from the type of power source indicated on the marking label. If you are not sure of the type of power supply to your home, consult your appliance dealer or local power company. For video products intended to operate from battery power, or other sources, refer to the operating instructions.
11. **Grounding or Polarization**-This video product is equipped with a polarized alternating-current line plug (a plug having one blade wider than the other). This plug will fit into the power outlet only one way. This is a safety feature. If you are unable to insert the plug fully into the outlet, try reversing the plug. If the plug should still fail to fit, contact your electrician to replace your obsolete outlet. Do not defeat the safety purpose of the polarized plug.



AC POLARIZED PLUG

12. **Power-Cord Protection**-Power-supply cords should be routed so that they are not likely to be walked on or pinched by items placed upon or against them, paying particular attention to cords at plugs, convenience receptacles, and the point where they exit from the appliance.
13. **Protective Attachment Plug** - The appliance is equipped with an attachment plug having overload protection. This is a safety feature. See Instruction Manual for replacement or resetting of protective device. If replacement of the plug is required, be sure the service technician has used a replacement plug specified by the manufacturer that has the same overload protection as the original plug.
14. **Outdoor Antenna Grounding**-If an outside antenna or cable system is connected to the video product, be sure the antenna or cable system is grounded so as to provide some protection against voltage surges and built up static charges. Section 810 of the National Electrical Code, ANSI/NFPA No. 70-1984, provides information with respect to proper grounding of the mast and supporting structure, grounding of the lead-in wire to an antenna discharge unit, size of grounding conductors, location of antenna-discharge unit, connection to grounding electrodes, and requirements for the grounding electrode. See Figure 1.
15. **Lightning**-For added protection for this video product receiver during a lightning storm, or when it is left un-attended and unused for long periods of time, unplug it from the wall outlet and disconnect the antenna or cable system. This will prevent damage to the video product due to lightning and power-line surges.
16. **Power Lines**-An outside antenna system should not be located in the vicinity of overhead power lines or other electric light or power circuits, or where it can fall into such power lines or circuits. When installing an outside antenna system, extreme care should be taken to keep from touching such power lines or circuits as contact with them might be fatal.
17. **Overloading**-Do not overload wall outlets and extension cords as this can result in a risk of fire or electric shock.
18. **Object and Liquid Entry**-Never push objects of any kind into this video product through openings as they may touch dangerous voltage points or short-out parts that could result in a fire or electric shock. Never spill liquid of any kind on the video product.

19. **Servicing**-Do not attempt to service this video product yourself as opening or removing covers may expose you to dangerous voltage or other hazards. Refer all servicing to qualified service personnel.
20. **Damage Requiring Service**-Unplug this video product from the wall outlet and refer servicing to qualified service personnel under the following conditions:
  - a. When the power-supply cord or plug is damaged.
  - b. If liquid has been spilled, or objects have fallen into the video product.
  - c. If the video product has been exposed to rain or water.
  - d. If the video product does not operate normally by following the operating instructions. Adjust only those controls that are covered by the operating instructions as an improper adjustment of other controls may result in damage and will often require extensive work by a qualified technician to restore the video product to its normal operation.
  - e. If the video product has been dropped or the cabinet has been damaged.
  - f. When the video product exhibits a distinct change in performance-this indicates a need for service.
21. **Replacement Parts**-When replacement parts are required, be sure the service technician has used replacement parts specified by the manufacturer or have the same characteristics as the original part. Unauthorized substitutions may result in fire, electric shock or other hazards.
22. **Safety Check**-Upon completion of any service or repairs to this video product, ask the service technician to perform safety checks to determine that the video product is in proper operating condition.
23. **Carts and Stands**-The appliance should be used only with a cart or stand that is recommended by the manufacturer.
24. An appliance and cart combination should be moved with care. Quick stops, excessive force, and uneven surfaces may cause the appliance and cart combination to overturn.



**FIGURE 1  
EXAMPLE OF ANTENNA GROUNDING ACCORDING TO  
NATIONAL ELECTRICAL CODE INSTRUCTIONS  
CONTAINED IN ARTICLE 810 - "RADIO AND TELEVISION EQUIPMENT"**

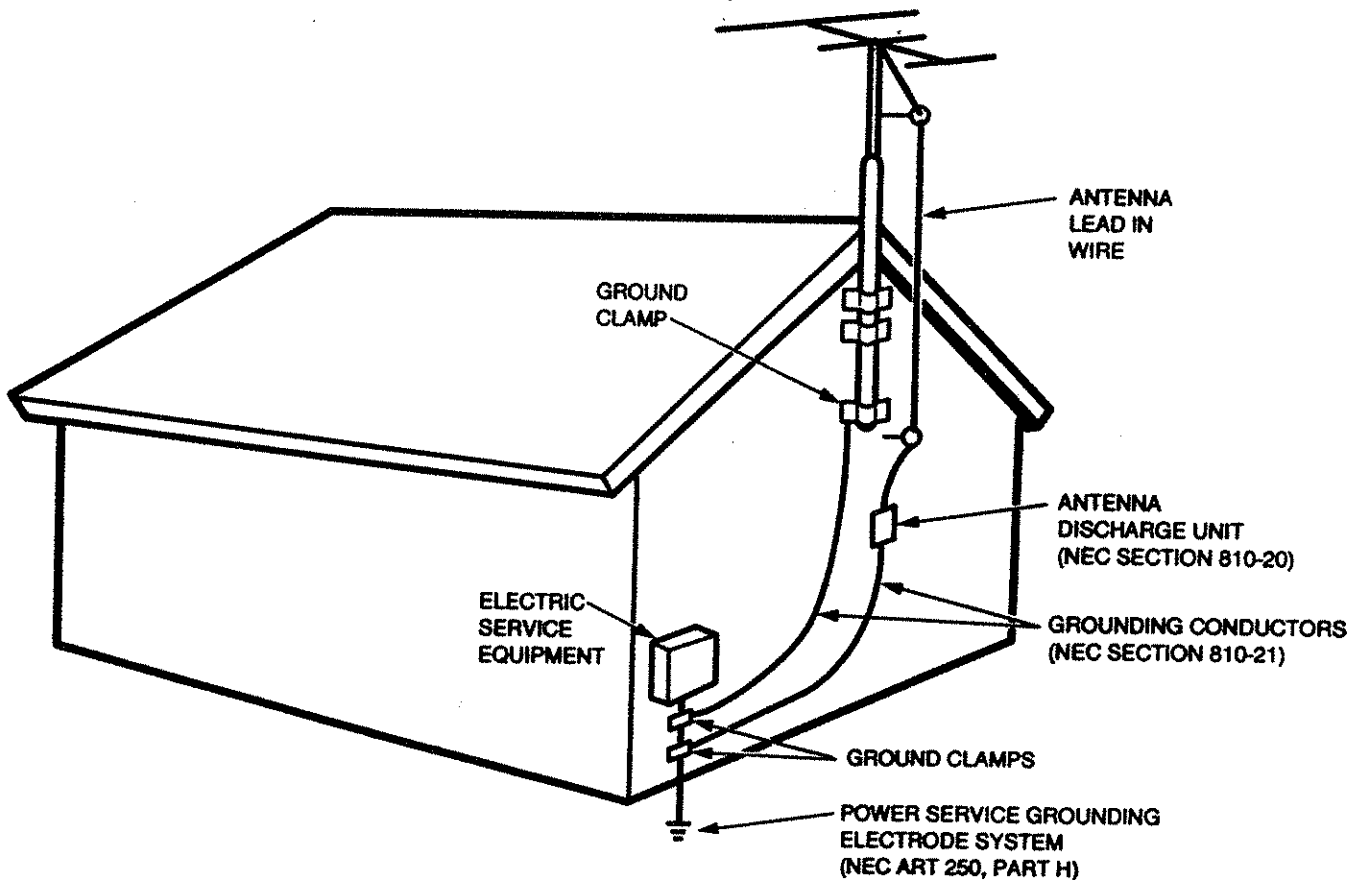

NEC - NATIONAL ELECTRICAL CODE

This Class B digital apparatus meets all requirements of the Canadian Interference - Causing Equipment Regulations.

Cet appareil numérique de la Classe B respecte toutes les exigences du Règlement sur le matériel brouilleur du Canada.

## LOCATION AND FUNCTION OF PARTS AND CONTROLS

### REAR PANEL CONNECTIONS (See pages 3, 77 - 80.)

All connections to the rear panel should be made with entire power off to the system. To avoid mis-connection, it is advisable to connect one cable at a time between the different components. This is the safest way to avoid cross-connecting channels or mixing-up signal inputs with outputs.

#### **A** FM antenna terminal (75 ohms)

For connecting an external FM antenna with a coaxial cable, or for connecting a cable network FM source.

#### **AM antenna and ground terminals**

For connecting the supplied AM loop antenna. Use the terminals marked "AM" and "GND".

The supplied AM loop antenna will provide good AM reception in most areas. Position the loop antenna to the best reception.

#### **B** CD IN jacks

Connect to the CD player.

#### **C** TAPE IN/OUT jacks

Connect the IN jacks to the output (PLAY, OUT) jacks of the tape deck. Connect the OUT jacks to the input (REC, IN) jacks of the tape deck.

#### **D** DSS/TV IN (AUDIO) jacks

Connect to the AUDIO output jacks of your Satellite tuner or TV tuner.

#### **E** LD IN (AUDIO) jacks

Connect to the AUDIO output jacks of the Laser Disc player.

#### **F** DVD IN (AUDIO) jacks

Connect to the AUDIO output jacks of the Digital Video Disc player.

#### **G** VCR IN/OUT (AUDIO) jacks

Connect the IN jacks to VCR's audio output (OUT) jacks. Connect the OUT jacks to VCR's audio input (IN) jacks.

#### **H** MULTI OUT jacks

Connect to the input jacks of the amplifier used to drive the speakers in another room, used as a multi-room (Second zone).

#### **I** DSS/TV IN (VIDEO/S-VIDEO) jacks

Connect the TV IN jack to the video output of the Satellite tuner or TV tuner. You can select the S-VIDEO or composite (VIDEO) according to the Satellite tuner or TV tuner.

#### **J** LD IN (VIDEO/S-VIDEO) jacks

Connect the LD IN jack to the video output of the LD player. You can select S-VIDEO or composite (VIDEO) according to the LD player.

#### **K** DVD IN (VIDEO/S-VIDEO) jacks

Connect the DVD IN jack to the video output of the DVD player. You can select S-VIDEO or composite (VIDEO) according to the DVD player.

#### **L** VCR IN/OUT (VIDEO/S-VIDEO) jacks

Connect the VCR IN jack to VCR's video output (OUT) jack. Connect the VCR OUT jacks to VCR's video input (IN) jack. You can select S-VIDEO or composite (VIDEO) according to the VCR.

#### **M** TV MONI. (VIDEO/S-VIDEO) output jacks

Connect the TV MONI jack to your TV's video input (VIDEO IN) jack. You can connect your video equipment by using either the S-VIDEO jacks or instead using the composite (VIDEO) jacks.

#### **N** MULTI ROOM jack

Connect to an third party multi-room remote control device, available from your Marantz dealer.

#### **O** PRE OUT jacks

Jacks for front, center and surround use are provided. Use these jacks for connection to power amplifier in case it is used.

#### **P** SUB WOOFER output jack

Connect to the MAIN IN jacks of the SUB WOOFER CHANNEL power amplifier.

#### **Q** DIGITAL INPUT jacks

##### **AC-3 RF In Jack**

Connect the Dolby Digital (AC-3) RF Output jack of compatible Laser Disc player to this jack.

##### **IMPORTANT NOTE:**

This input jack is for Dolby Digital (AC-3) RF signal only.

Do not connect a normal audio output terminal of a Laser Disc player, etc. to this AC-3 RF in jack.

##### **AC-3/PCM Coaxial In Jack**

This terminal connect to the coax data stream Dolby Digital (AC-3) output of future AC-3/PCM digital products such as DVD and DSS.

##### **AC-3/PCM Optical In Jack**

This terminal is used for connection to the optical data stream Dolby Digital (AC-3) output of future AC-3/PCM digital products such as DVD and DSS. To avoid dust contamination, leave the protective cap inserted unless the jack is in use.

##### **IMPORTANT NOTE:**

These input jack are for Dolby Digital (AC-3)/PCM digital signals only. Do not connect standard audio output to these Dolby Digital (AC-3)/PCM digital input jacks. The sampling frequencies which can be supported by SR780 are 32 kHz, 44.1 kHz and 48 kHz only.

#### **R** REMOTE CONT. IN/OUT terminals

Connect to a Marantz component equipped with remote control (RC-5) terminals.

#### **S** SPEAKER terminals

##### **CENTER speaker output terminals**

Connect to the center speaker.

##### **SURROUND speaker output terminals**

Connect to the surround (rear) speakers.

##### **FRONT speaker output terminals**

Connect to the front speakers.

#### **T** AC OUTLETS

Connect the power cables of components such as a cassette deck and CD player to these outlets. Both SWITCHED and UNSWITCHED outlets are provided. The one marked SWITCHED provides power only when the SR780 is turned on and is useful for component which you use every time you play your system such as an equalizer or your most-used sound source. The one marked UNSWITCHED is always live as long as the SR780 is plugged into a live outlet. A component connected here may be left on permanently, or may be switched off with its own power switch.

##### **Caution:**

In order to avoid potential turn-off thumps, anything plugged in here should be powered up BEFORE the SR780 is turned on.

#### **U** POWER cable

Plug into a household AC power outlet.



## INTRODUCTION

Thank you for purchasing the Marantz SR780 Dolby Digital Surround receiver. This remarkable component has been engineered to provide you with many years of home theater enjoyment. Please take a few minutes to read this manual thoroughly before you connect and operate the SR780. As there are a number of connection and configuration options, you are encouraged to discuss your own particular home theater setup with your Marantz A/V specialist dealer.

## DESCRIPTION

Dolby Digital (also known as AC-3) is a new technology that was originally developed to provide six separate channels of high quality discrete multi-channel sound for motion picture theaters. The Marantz SR780 Dolby Digital receiver brings that same high quality sound into your home when used with a compatible laser disc player, as well as from future Dolby Digital sources such as DSS, Digital Video Disc (DVD) and High Definition Television (HDTV). The wide dynamic range of Dolby Digital enables the Marantz SR780 to reproduce soundtracks with their full fidelity and a realism that is not possible with conventional matrix surround systems.

The SR780 is manufactured under license from Dolby Laboratories Licensing Corporation. "Dolby", "AC-3", and the double-D symbol  are trademarks of Dolby Laboratories Licensing Corporation.

## FEATURES

- High quality Dolby Digital (AC-3) DSP decoding chip.
- AC-3 RF input, for connection to compatible laser disc players such as the Marantz LV520 with an AC-3 RF output.
- Coaxial and Optical Digital AC-3/PCM inputs, for connection to other sources, such as DVD and/or DSS.
- Digital Dolby Pro Logic decoding provides wide dynamic range, low distortion, and high imaging accuracy.
- Discrete pre-amp outputs allow the use of connections to external power amplifier(s).
- Multiple high power, high current amplifier stages
- Integral AM/FM tuner
- On Screen Display with composite and "S" video
- Cinema Re-EQ  
Cinema Re-EQ and the Re-EQ logo are registered trademarks of Lucas film Ltd. Manufactured under licence of Lucas film Ltd.
- Composite and "S" video switching
- Separate dedicated Multi-Room stereo pre-amp outputs provide for dual zone independent operation (requires optional IR-92 sensor kit and an external stereo power amplifier and speakers for the second zone)
- Infrared remote control with learning capability

## PRECAUTIONS IN CONNECTION

- Be sure to unplug the power cable from the AC outlet or turn off the POWER/STANDBY switch before proceeding with any connection.
- Connect one cable at a time observing the "input" and "output".  
This will avoid any cross connection between channels and signal inputs and outputs.
- Insert the plugs securely. Incomplete connection may result in noise.
- Prior to connecting other audio and video equipment to the SR780, please read their owner's manuals.

## INSTALLATION

If this unit or another electronic device incorporating a microcomputer is used at the same time with the tuner or television, picture disturbance or noise may occur. In such a case, install the unit according to the following guide points.

- Separate the unit as far as possible from the tuner or television.
- Place the antenna wire for the tuner or TV apart from the power cable and audio and video connection cables of this unit.
- Since the phenomenon is likely to occur when using an indoor antenna and/or 300-ohm feeder wire, we recommend using an outdoor antenna and 75-ohm coaxial cable.

## FRONT PANEL FEATURES (See page 3)

### ① POWER switch and STANDBY Indicator

When this switch is pressed once, the power turns ON and display appears on the display panel. When pressed again, the power turns OFF and the **STANDBY** indicator lights.

When the switch is the OFF position, the apparatus is NOT disconnected from the AC supply mains.

### ② NIGHT button

Pressing this button prevents the AC-3 digital signal from playback at a loud voice. This function reduces the voice by 1/3 to 1/4 at maximum. Thus, it eliminates the occurrence of an abruptly loud voice at night. However, the function is valid only for the case when the AC-3 digital signal is entered into RF, OPTICAL or COAXIAL and data to compress the voice exists in the signal to be played back.

### ③ PHONES jack for stereo headphone

Conventional dynamic headphones can be plugged in here.

#### Note:

When the headphones plug is inserted, the surround mode is switched automatically to **STEREO** and the sound from the speakers are muted. At this time, the speaker setting is set to none temporarily except front ch.. The surround mode returns to the previous mode as soon as the plug is removed from the jack.

### ④ FUNCTION SELECTOR buttons (DIGITAL INPUT)

These buttons are a button for selecting a source connected to RF, OPTICAL or COAXIAL input jack. However, the source signal selected with the FUNCTION SELECTOR buttons (AUDIO/VIDEO) is output at the TAPE or VCR output jack.

### ⑤ MODE UP and DOWN buttons

Selects the surround modes.

When these buttons are pressed, the **SURROUND** mode is changed in following sequence:



#### Note:

The **AC-3** mode can be selected only in RF, OPTICAL, COAXIAL.

### ⑥ MULTI ROOM button

Pressing this button switches the unit to multi room mode. "MULTI ROOM" appears in the display.

### ⑦ FUNCTION SELECTOR buttons (AUDIO/VIDEO)

These buttons are used to select the source to be input to the unit via the rear panel input jacks.

The video function selector, such as **DVD**, **DSS/TV**, **VCR**, **LD** and **AUX**, selects video and audio simultaneously. Audio function sources such as **FM/AM**, **TAPE** and **CD** may be selected in conjunction with a Video source. This feature (Sound Injection) combines a sound from one source with a picture from another.

Choose the video source first, and then choose another audio source to activate this function.

### ⑧ BASS and TREBLE tone controls

These controls are used to boost or cut high and low frequencies. At their center detent position, there is no boost or cut.

**TREBLE:** Adjusts the tone of high-frequency sound for LEFT, CENTER and RIGHT ch.

**BASS:** Adjusts the tone of low-frequency sound for LEFT, CENTER, RIGHT and SUBWOOFER ch.

### ⑨ BALANCE control

Adjusts the sound volume balance between the left and right of the front speakers and headphone channels.

### ⑩ AUX Input jacks

These auxiliary video/audio input jacks accept the connection of a camcorder, portable VCR, etc.

To make proper connections, refer to the owner's manuals of the auxiliary components.

### ⑪ VOLUME control

Adjusts the overall sound level. Turning the control clockwise increases the sound level.

## TUNER CONTROL BUTTONS

### ⑫ FM MODE button

When the FM band is selected, press button to select the auto stereo mode or mono mode. The **AUTO** indicator lights in the auto stereo mode.

### ⑬ P.SCAN (preset scan) button

This button is used to scan preset stations automatically.

When pressed, "P-SCAN" blinks in the display and the tuner starts scanning the preset stations of all band. Press again to cancel the P-SCAN.

### ⑭ CLEAR button

Press this button to cancel the station-memory setting mode or preset scan tuning.

### ⑮ MEMO (memory) button

Press this button to enter the tuner preset memory numbers and station name, or the sleep timer period.

### ⑯ TUNING UP and DOWN buttons

During reception of AM or FM, you can scan the other frequencies by pressing these buttons.

### ⑰ PRESET UP and DOWN buttons

During reception of AM or FM, you can select another preset station by pressing these buttons.

## OTHERS

### ⑱ DISPLAY

Displays the operating status of the SR780.

### ⑲ ATT (Attenuator) button

**ATT** (Attenuator) button attenuates the **AUDIO** signal selected with the **FUNCTION** buttons (**AUDIO**, **AUDIO/VIDEO**). When the input signal is too great and the voice distorts even by throttling the **SR780 VOLUME** control, turn on the function. "ATT" is displayed when this function is activated.

The signal input level is reduced by about the half. Attenuator is invalid for use with the output signal of "REC OUT" (TAPE and VCR out).

### ⑳ OSD (On-Screen Display) button

Press this button to display the current setting status of the SR780 on the TV screen.

Once the button is pressed, the on-screen display is turned on and each a control button related to the SR780 is pressed thereafter, the information will be displayed on the TV screen.

When the button is pressed again to turn the on-screen display off, it disappears from the TV screen. (Refer to "On-screen display" on page 24.)

### ㉑ CINEMA RE-EQ button

Press this button to active the Cinema Re-EQ. "RE-EQ" is displayed when this function is activated. Cinema Re-EQ and the Re-EQ logo are registered trademarks of Lucas film Ltd. Manufactured under licence of Lucas film Ltd.

#### Note:

The Cinema Re-EQ activates only Dolby Digital (AC-3), Pro Logic and 3-stereo mode.

### ㉒ INFRARED SENSOR window

This window receives infrared signals from the remote control unit. Aim the remote control unit to this sensor window for proper signal transmission.



## REMOTE CONTROL BUS CONNECTIONS

This unit is equipped with a remote control function. By connecting this unit's remote control jacks to a Marantz CD player or tape deck equipped with remote control (RC-5) jacks, it allows system remote control operation. Connect **REMOTE CONT. OUT** jack of SR780 to **REMOTE CONT. IN** of other Marantz equipment, i.e. CD player or Cassette deck, by using an RCA pin cable.

### Note:

If a component equipped with remote control (RC-5) jacks has an INT/EXT switch on the rear panel, set the switch to EXT when using the system control function.

### (Connection example)

SR780 rear panel  
or MA500 rear panel      CD player rear panel      Tape deck panel

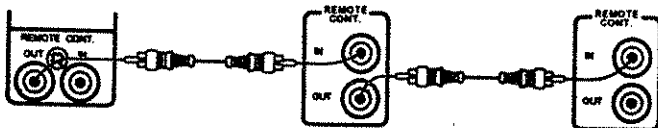

## Controlling the power ON/OFF of a power amplifier connected to the SR780 through Marantz remote control

1. If you connect the MA500 power amplifier to the SR780, set the Bus System Selector switch of the MA500 to "System 2". Now the MA500 can be turned ON / OFF in synchronism with the power ON / OFF of the SR780.

### Notes:

- Be sure to connect the remote control bus before the procedure above.

## CONNECTION FOR A SUBWOOFER

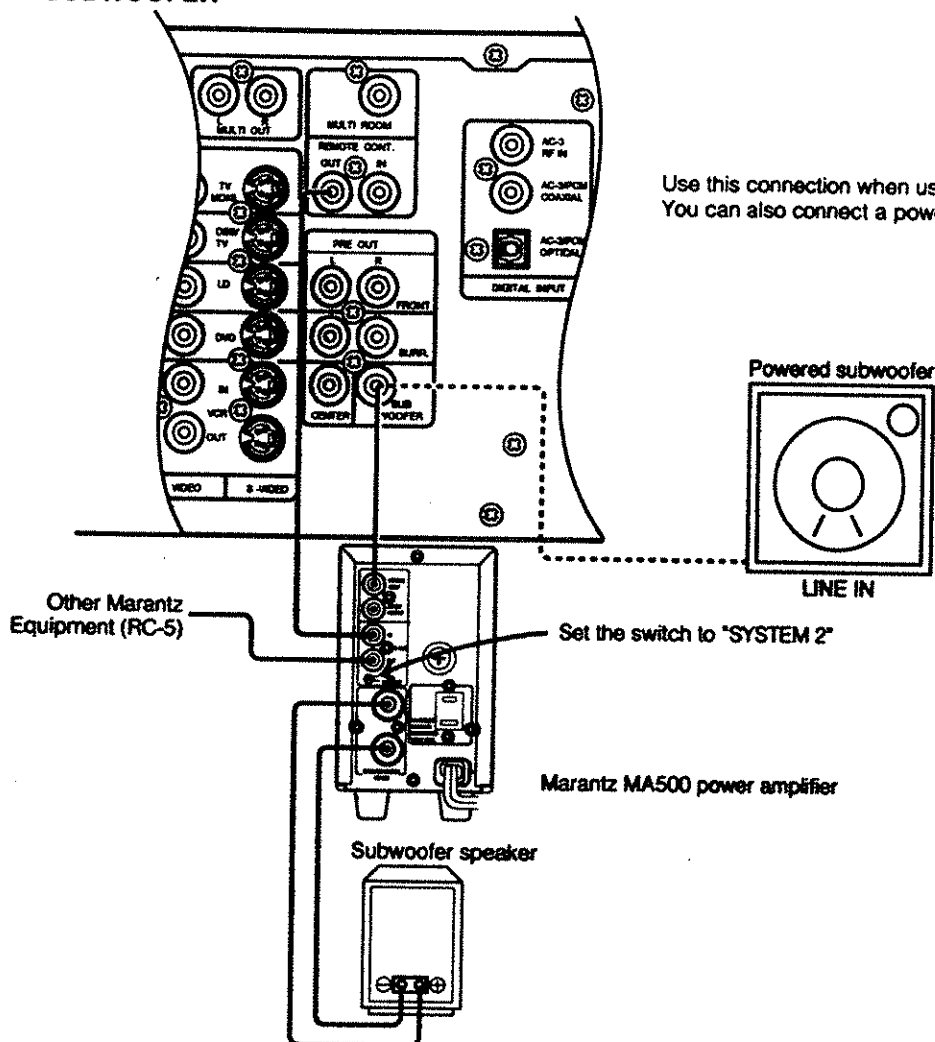

## SET-UP AND CALIBRATION

After completion of all connecting arrangements, please do the following procedure for the set-up and calibration before play-back.

### SPEAKER SELECTION

The home theater system you already have installed should function provided that there are left, center and right front speakers, left and right rear/surround speakers and a subwoofer. For best result we recommend that the front speakers be of the same type, with identical or similar driver units. This will deliver smooth pans across the front sound stage as the action moves from side to side.

Your center channel speaker is very important as over 80 % of the dialog from a typical motion picture emanates from the center channel. Rear channel speaker need to be identical to the front channel speakers, but they should be of high quality. One of the benefits of Dolby Digital (AC-3) is that they surround channels are full range, while they were frequency limited in earlier "Pro Logic" type systems. Bass effects are an important part of home theater. For optimal enjoyment a subwoofer should be used as it is optimized for low frequency reproduction. If you have full range front speakers, however, they may be used in place of a subwoofer with proper setting of the switches in menu system.

Speaker system configurations (diagram, as currently used)

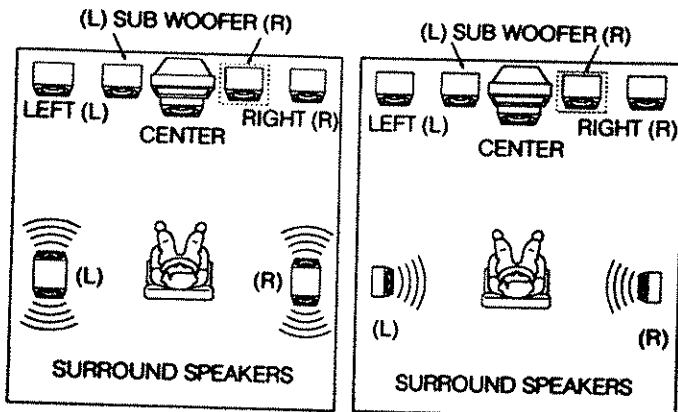

If possible, mount the surround speakers on the walls to the sides of the viewing area, 2-3 feet above seated viewers, firing straight across at each other.

### SPEAKER SETTING

Since the SR780 may be used with a wide variety of speaker types, it is important that you adjust the speaker setting in menu system before using SR780. Setting these menu will tell the SR780 what type of speakers you are using so that the audio outputs will be directed to the proper speaker.

In general, a "Large" speaker is defined as a traditional full range speaker that includes a woofer and is capable of reproducing sounds below 100 Hz. For the purposes of this product, a "Small" speaker is one that is not capable of delivering sounds below 100 Hz. Most "satellite" type speakers fall into this category. Before setting the menu make note of the type of front, center and rear speakers that will be used. For further clarification of your speakers' type consult the speaker owner's manual and look on the "specifications" page to find the frequency range.

When you have the information on your speakers, set the four setting as follows;

#### 1) Front Speakers in Setup Menu 1/4

This setting determines the frequency range of the front left/right speakers. Select Large or Small depending on the type of speaker you will be using. The factory default setting is "Small".

**Large:** Select this position if you are using full range speakers that are capable of reproducing sounds below 100 Hz. In this position, the output to the front left/right output jacks is full range.

**Small:** Select this position if you have small, frequency limited satellite type speakers that do not reproduce sounds below 100 Hz. Do not select this position if your system does not include Sub woofer. In this position, low frequency sounds are routed to the **SUBWOOFER OUTPUT** jacks.

#### 2) Surround Speakers in Setup Menu 1/4

This setting determines the frequency range of the rear surround speakers. Select Large, None or Small depending on the type of speakers you will be using. The factory default setting is "Small".

**Large:** Select this position if you are using traditional, large speakers that are capable of reproducing sounds below 100 Hz. In this position, the output to the audio feed to the surround output jacks is full range.

**None:** Select this position if you will not be using any rear channel/surround speakers.

In this position the full range surround audio that would otherwise be routed to the surround channels will be mixed in with the **FRONT LEFT** and **FRONT RIGHT** audio.

**Small:** Select this position if you have small, frequency limited satellite type speakers that do not reproduce sounds below 100 Hz. In this position, low frequency sounds are routed to either the **SUBWOOFER OUTPUT** or the **FRONT LEFT** and **FRONT RIGHT** speakers depending on the setting of the **SUBWOOFER** speaker.

#### 3) Center Speakers in Setup Menu 1/4

This setting determines the frequency range for the center channel speaker. Select Large, None or Small depending on the type of center channel speaker installed. The factory default setting is "Small".

**Large:** Select this position if the center channel speaker is a large, full range model capable of reproducing sounds below 100 Hz. In this position, the out put to the audio feed to the Center Channel output jack is full range.

**None:** Select this position if you will not be using any center channel speakers.

In this position the full range signal audio that would otherwise be routed to the center channel will be mixed in with the **FRONT LEFT** and **FRONT RIGHT** audio.

**Small:** Select this position if you have small, frequency limited satellite type speakers that do not reproduce sounds below 100 Hz.

In this position, low frequency sounds are routed to either the **SUBWOOFER OUTPUT** or the **FRONT LEFT** and **FRONT RIGHT** speakers depending on the setting of the **SUBWOOFER** speaker.

#### 4) Subwoofer in Setup Menu 1/4

Set this setting to determine the routing of low frequency sounds for all channels. The factory default setting is "ON", to indicate that a subwoofer is present.

**On:** Select this position if the SR780 is connected to an amplifier or receiver equipped with a Subwoofer INPUT terminal, or if directly connected to a powered subwoofer.

**Off:** Select this position if a Subwoofer will not be used.

In this position the low frequency sounds (below 100 Hz) will be routed to the **FRONT LEFT**, **RIGHT** terminals, depending on the setting of the speaker set up for those channels.

**Note:**

Subwoofer cannot be set "Off" if the front speaker is set "Small".

# CALIBRATION

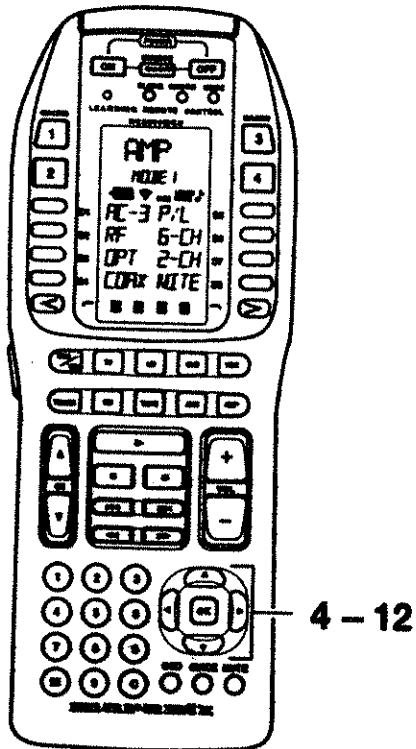
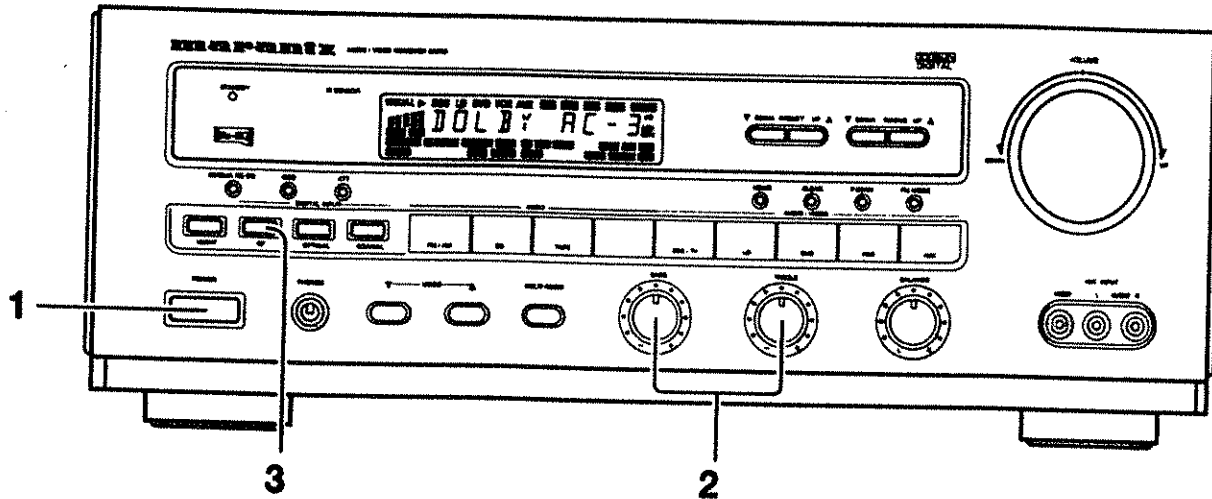

1. Turn the SR780 power ON.
2. Place the tone controls (BASS, TREBLE) at the middle position.
3. Press the RF button to select the Dolby Digital (AC-3) mode of the RF digital input.
4. Press any one of the cursor buttons (▲, ▼, ►, ◀ OK) to display the "MAIN MENU" of the on-screen display menu.
  - Press cursor button ▼ to move the arrow-shaped cursor to item "SETUP MENU" and press the OK button.
  - With cursor button ▼ and ◀ or ►, set the cursor to LARGE if your front-channel speaker system is a Large speaker.
  - Set the cursor to SMALL if the front-channel speaker is a small speaker. The surround-channel speaker is set as same procedure.
  - With cursor button ▼ and ◀ or ►, set the cursor to LARGE if your center-channel speaker system is a Large speaker.
  - Set the cursor to SMALL if the center-channel speaker is a small speaker.
  - Set the cursor to NONE if your speaker system does not use the center-channel speaker.
  - With cursor button ▼ and ◀ or ►, set the cursor to ON if your speaker system use a subwoofer.
  - With cursor button ◀ or ►, set the cursor to OFF if your speaker system does not use a subwoofer.
5. Press cursor button ▼ to move the cursor to "RETURN TO MAIN MENU" and press the OK button.

**Note:**  
You cannot set to OFF the subwoofer if you set the front channel-speaker to small.

OSD MAIN MENU  
 ▷ 1 INPUT SELECTOR  
 2 SURROUND MODE  
 3 TEST TONE  
 4 MULTI ROOM SEL : OFF  
 5 SLEEP TIMER : OFF  
 6 SET UP MENU  
 MENU OFF

OSD MENU 6  
 SETUP MENU 1/4  
 SPEAKER SETTING  
 ▷ FRONT CH. : SMALL  
 ▽ SURROUND CH. : SMALL  
 ▽ CENTER CH. : SMALL  
 SUBWOOFER : ON  
 RETURN TO MAIN MENU

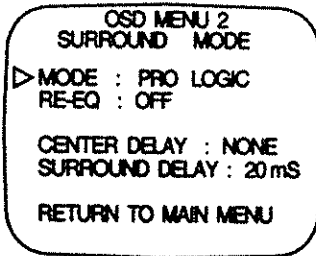
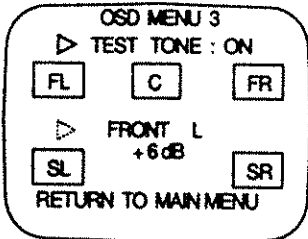
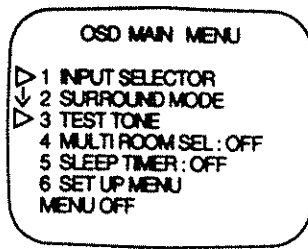

6. Press cursor button ▲ or ▼ to move the cursor to "TEST TONE" and press the OK button.
- You can use the cursor button ◀ or ▶ to move to the "OSD MENU 3".

7. Press the OK button to turn on the TEST TONE. Note that a test signal noise will be heard from the FRONT LEFT CH speakers. Adjust the test signal noise output to the appropriate level by using the master volume control.

8. Press the OK button or the CH.SEL (channel select button), each press changes the speaker channel generating the test tone in the following order:



After each press of the CH.SEL button, adjust the level by using the CH.LEVEL ▲ and ▼ buttons or cursor ◀ and ▶ buttons until the sound level from each speaker appears equal.

**Note:**

When either the CENTER CH or SURROUND CH SET UP set to NONE the test tone skips each channel. The test tone is not output to the subwoofer irrespective of ON or OFF selection.

9. When the balance between the volume levels of different speakers has been adjusted, stop the test tone generation by pressing the cursor button ▲ and ◀ or ▶ so that the cursor is set to other menu. The volume levels of the speaker channels set above will be used in common for the **Dolby Digital (AC-3)**, **DOLBY PRO LOGIC**, **MOVIE** and **3-STEREO** surround modes.

**10. Delay Time Setting**

- ① On the MAIN MENU, move the arrow-shaped cursor to "SURROUND MODE" and press the OK button.
- ② Press cursor button ▼ to move the cursor to center or surround channel.
- ③ Select the desired delay time with cursor buttons ◀ and ▶.
- ④ Press the OK button or cursor button ▼ or ▲ to complete the setting.

Normally use 20 ms. Use 25 or 30 ms if you are much closer to the rear speakers than the front speakers.

In the **DOLBY DIGITAL (AC-3)** mode, the delay time is variable in the following sequence.



- ⑤ For more information about setting the delay time, please turn to Page 32.

**Notes:**

Once the delay time is set, it is stored automatically as a common setting with **DOLBY DIGITAL**. Unless it is set again, the same delay setting will be applied every time **DOLBY DIGITAL** is selected.

Once this procedure for the set-up and calibration has been done, there should be no need to repeat it in daily use. A monthly check of channel levels is recommended; simply press the TEST button, followed by repeated pressing of the CH.SEL button to verify that all channels are operational and at the same level. Once done press the TEST button again to end the test.

The DELAY CONTROL of the CENTER CH. is available only when the **Dolby Digital (AC-3)** mode is selected. The SURROUND CH DELAY has a time difference of 15ms between **Dolby Digital (AC-3)** and **PRO LOGIC** modes.

## REMOTE CONTROL UNIT RC2000MKII

• The remote control unit provided with the SR780 is a "learning"-type, programmable unit capable of controlling almost any component in your system, as well as the Marantz D-BUS components (RC-5). The components to be controlled can be selected with ten buttons.

### OPERATION

The provided remote control unit (RC2000MKII) is a system remote controller. The **POWER** button [4], 10-key numeric buttons [12] and control buttons [13] are used in common across different input source components.

The input source system controlled with the RC2000MKII changes when one of the input selector buttons [9] is pressed.

• Example: To select the LD player as the input source and play an LD on it

Press the **LD** button twice within 2 seconds.

The input function of the SR780 is switched to LD and the RC2000MKII is set for control of the LD player.

Press the **PLAY** button [15] to play an LD.

## FUNCTION AND OPERATION

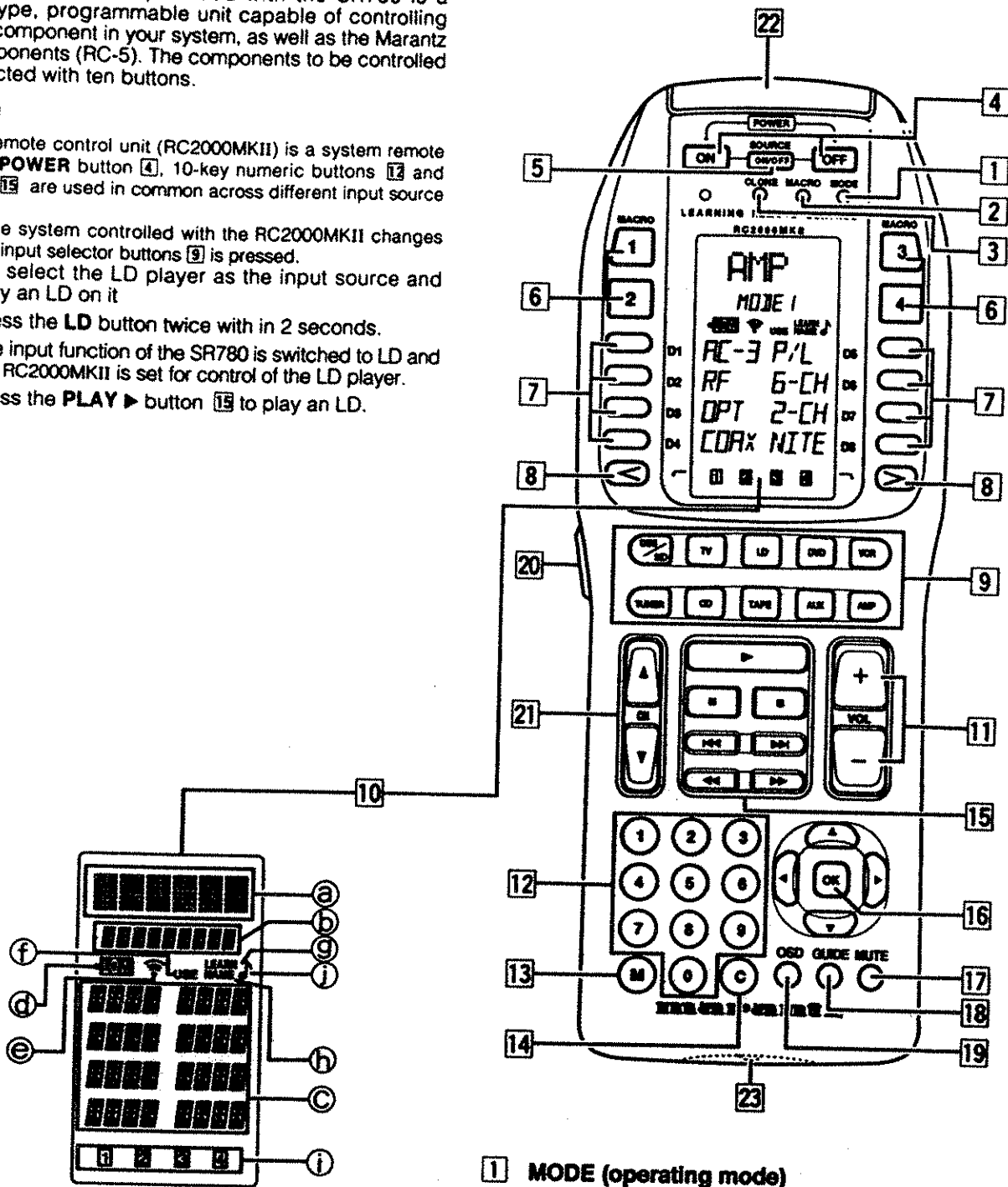

### 1 MODE (operating mode)

This button is used to change from normal operation to the learning mode, and is used when "learning" commands from other brands of A/V components. Each time this button is pressed (using a small pointed instrument, such as the tip of a paper clip) the mode changes as follows: LEARN → USE → NAME. As the mode changes, the LCD display will show which mode is currently selected.

### 2 MACRO (for multiple step macro functions)

This button is used to memorize a series of functions. When this button is pressed, the RC2000MKII changes to macro programming mode, and is ready to learn a sequence of remote control commands.

**3 CLONE**

The RC2000MKII has the ability to "replicate" itself, downloading all of its internal pre-programmed and user-programmed commands to another RC2000MKII. This button is used when you wish to "teach" another RC2000MKII all of the customized commands you've already programmed in this RC2000MKII.

**4 POWER ON and OFF**

These two buttons are used to turn the main component's (amplifier or receiver) AC power on and off. We provide both ON and OFF commands so that your A/V system is remote compatible with external infrared controllers, such as in-wall key pads, etc.

**5 SOURCE ON/OFF**

This button is used to turn the AC power on and off to any of your A/V source components that have their own remote control turn-on and turn-off commands, such as TV, laser disc player, VCR, etc.

**6 MACRO 1-4**

Each of these 4 buttons can be programmed with a "string" of commands, called a macro, to initiate a sequence of remote codes to achieve a particular result. For example, a macro button could be programmed to turn on the main system power, then turn on a particular source component (such as a laser disc player), then turn on the TV set, set the TV to AUX video input, and then adjust the surround processor to the home theater surround decoding mode, then activate the laser disc player's PLAY function. This means that by pressing one macro button, you can achieve the same result as pushing up to 20 buttons in sequence.

**7 DIRECT**

With today's high performance A/V systems, it is not unusual for each component in your system to have dozens of specialized command functions. If we were to duplicate all of those commands for each component onto the RC2000MKII key pad, we could easily exceed 300 buttons for an entire home theater system, which would result in either a huge key pad, or buttons of infinitesimal size. The DIRECT command buttons (4 on each side of the LCD display, 8 total) work with the PAGE buttons (4 pages for each source component) to provide up to 32 dedicated specialized functions for each of the 10 function input selectors. Each DIRECT function may also be provided with an alphanumeric function indicator visible in the LCD display. You may even change the displayed name of each function to another name, if you wish.

**8 PAGE**

Used to select any 1 of the 4 pages of 8 functions for each DIRECT button, as explained above.

**9 FUNCTION**

Press one of these buttons once or twice to select a particular source component. For example, to set the amplifier or receiver to the laser disc input, press the LD button twice within 2 seconds. Along with the source selection, special functions may become available (the DIRECT keys), as well as activating the transport function keys, so that you can now directly operate the laser disc player from the RC2000MKII. If you wish, you may even re-program the status indicators in the LCD window to reflect your own particular function name whenever that source (function) button is selected.

**Here are the button names and their functions:**

<b>LD</b>	: Laser disc player
<b>TV</b>	: Television
<b>VCR</b>	: Video cassette recorder
<b>DSS/MD</b>	: Digital satellite decoder or mini disc player
<b>AUX</b>	: Can be used for an auxiliary source component
<b>TUNER</b>	: AM/FM tuner, or AM/FM tuner section of a receiver
<b>CD</b>	: Compact disc player or changer
<b>TAPE</b>	: Audio tape deck, or digital audio recorder
<b>AMP</b>	: Amplifier or receiver control functions
<b>DVD</b>	: Digital video disc player

**Note:**

Press a function selector button only once to select the LD player, etc.

Remember, when you press a function selector button only once, the RC2000MKII will not send out a remote control code to instruct the amplifier or receiver to change to that corresponding input, but the RC2000MKII keypad and DIRECT function commands will provide the selected component's specialized remote control codes. Press a function selector button twice within 2 seconds to change the function of the amplifier or receiver.

For example, if you press the LD function button twice within 2 seconds, the amplifier or receiver's input will immediately be switched to the laser disc input, and the keypad and DIRECT function commands for laser disc operation will be activated. Press the CD function button only once, the amplifier or receiver's input will not switch to the CD input, however the RC2000MKII keypad and DIRECT function commands for compact disc operation will be activated.

We have provided 10 popular function command selector buttons, based upon the typical input selections available with most quality A/V amplifiers (or receivers) including popular Marantz models.

The function button DSS/MD is a little different from the others, in that when you press this button, the RC2000MKII will send out a command to the amplifier or receiver to switch to the DSS input, and then the RC2000MKII keypad and DIRECT function commands will be configured for DSS (digital satellite system) control. We have included DSS commands within the RC2000MKII's pre-programmed memory for RCA brand DSS equipment. If you have another brand of DSS, you can "teach" the RC2000MKII with the remote control codes of your equipment.

**10 LCD window**

The LCD window provides a wealth of information, including function selection name, DIRECT function names, learning and programming steps, as well as useful indicators for battery status, and helpful indicators. The LCD window features back-lighting, making it easy to view when the room ambient light is very low.

**11 Volume up (+) and down (-)**

Used to raise and lower the main system volume level. Note that these buttons are clearly the largest size, and are conveniently located and contoured for easy operation, even in low lighting.

**12 Ten keypad**

Like a telephone key pad, the ten number buttons (0-9) are used to enter numeric digits, useful for finding a specific track on a CD, or to tune a pre-set radio station, etc. The "0" button performs the same operation as the "CLEAR" button on the SR780 main unit.

**13 MEMO**

This button is used to program your CD player's track memory, or to enter a VCR recording program, and can be used to provide the MEMO function included with other components in your system.

**14 CLEAR**

This button is used to cancel certain memory or programming operations. It operates differently from the "CLEAR" button on the SR780 main unit.

**15 Transport control functions**

These buttons provide transport commands for your source components, such as laser disc player, CD player, VCR, audio tape deck, etc., and are dependent on the function source selected. For example, when the RC2000MKII is set to LD (laser disc) mode, the transport keys will operate the laser disc player's PLAY, STOP, PAUSE, FAST FORWARD, FAST REVERSE, NEXT and PREVIOUS track functions. Change the RC2000MKII function selector to VCR, and these keys will then operate the VCR's transport command functions, etc.

**16 CURSOR buttons**

Some components feature menus that are navigated with up, down, left and right direction commands. The cursor buttons can be used to navigate within on-screen menus, for components such as amplifier or receiver, TV set, DSS/satellite tuner, etc. These buttons are also used for certain RC2000MKII programming functions.

**17 MUTE**

For those components (such as amplifier or receiver, TV, etc.) with a mute function, this button can be used to mute the sound temporarily.

**18 GUIDE**

This button is intended for owners of DSS (digital satellite system) or similar equipment, to activate the on-screen programming guide, used when changing channels etc.

**19 OSD (On Screen Display)**

Some components, such as an amplifier or receiver, TV set, etc., feature on screen display for operation and/or programming. The OSD button can be used to activate the on screen display, or turn it off if desired.

**20 LIGHTING**

Press this button to activate the back-lit LCD screen and back-lit keys independently SETUP mode. A quick touch is all that is necessary. The back-lighting will remain on for 3 seconds. If you wish, you can even re-program the RC2000MKII to shorten or lengthen the amount of time the back-lighting is activated when this button is pressed.

**21 Channel up(▲), down(▼)**

Press this button to change the tuner, TV, DSS or VCR preset channels to upward or downward.

**22 Transmitter window**

Infrared signals will emanate from behind this window. Simply aim the RC2000MKII towards the component(s) you wish to control. You may find that the RC2000MKII works fine when placed on a coffee table pointing towards your A/V system components.

**23 Receiving window**

Used when learning commands from other remotes, this window is placed at the bottom of the RC2000MKII, so that the two remotes are vertically oriented for easy transfer of remote control information. Later in this guide we will show you which of the RC2000MKII buttons can be "taught" new commands from other components.

**LIQUID CRYSTAL DISPLAY (LCD) WINDOW**

Within this display, all operating messages (function name, mode names, etc.) are shown. When a particular button is pressed (such as a transport command, like PLAY), its status will be shown in the display for 1 minutes. The display will continue to show the source function selected continuously, however.

**ⓐ Function Indication:**

The selected source function is displayed, such as LD, TV, etc., up to 6 characters maximum.

**ⓑ Status indication:**

The selected status of the present page, or other items, is displayed, up to 9 characters maximum.

**ⓒ Direct commands:**

8 DIRECT commands are available in 1 page, up to 4 characters maximum.

**ⓓ Battery Indicator:**

When the batteries are running low, this indicator will become visible. At this point, it will not be possible to learn any new remote codes, but normal remote control operation is still provided (including the use of any previously learned codes). At this point, you should consider changing the batteries soon. As time goes on, and the battery power diminishes further, this indicator will begin blinking. At this point, no remote commands will be transmitted. This is your signal to replace the batteries with fresh ones as soon as possible. Eventually, if you ignore the blinking battery indicator and do not install fresh batteries, then the batteries may eventually be totally exhausted, and the LCD display window will be completely blank. However, any previously learned commands and macros will not be erased from the microprocessor's memory.

The RC2000MKII is supplied with a full set of RC-5 remote control codes in permanent (non-volatile) memory. Even if the batteries are fully exhausted, the RC-5 codes (used for Marantz A/V components) and learned codes will never disappear.

We recommend that you use a quality brand of alkaline batteries, for best results and longest life. Newly available lithium "AA" batteries can even provide longer life than alkaline batteries, and are also recommended.

**ⓔ Transmit Indicator:**

When a button is pressed, this indicator shows that an infrared code is being transmitted.

**ⓕ USE Indicator:**

For normal operation, the USE indicator should be visible.

**ⓖ LEARN Indicator:**

Visible when the RC2000MKII is set to LEARN mode.

**ⓗ NAME Indicator:**

Visible when the RC2000MKII is in the learning mode, and function naming is being changed.

**ⓘ PAGE or MACRO Indicator:**

This indicator usually functions in association with the PAGE button **ⓑ**, but also functions as the MACRO indicator when the MACRO button **ⓓ** is pressed.

**ⓙ J Indicator:**

Visible when the RC2000MKII is set the beep function.

**Installing the batteries:**

The battery compartment is located on the rear panel. Please use only alkaline or lithium batteries, "AA" size. The RC2000MKII requires four AA batteries. There are markings in the battery compartment to show you the proper battery orientation. If after installing the batteries, you cannot see any indication in the LCD window when a button is pressed, re-check to ensure that the batteries are properly positioned in the compartment.

## RC2000MKII BASIC OPERATION

### USE Mode:

As supplied from the factory, the RC2000MKII is already permanently programmed with many pre-set commands common to Marantz and Philips equipment, as well as other brands of components that utilize the Philips RC-5 remote control language.

1. If the RC2000MKII is in another mode (LEARN, etc.), press the operation mode button [1] with the tip of a paper clip, until the USE indication appears.
2. Press one of the function buttons [9], to change to another component's commands such as LD (refer to Figure 1)

Figure 1

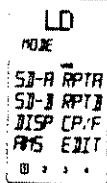

3. "LD" will be indicated within the LCD window, and the function codes will be set to operate the laser disc player, press the function button again within 2 seconds as well as changing the amplifier or receiver's input to laser disc.
4. Now you can operate the laser disc player. When a button is pressed, the symbol indicates that a remote code is being transmitted. Note that for a particular source component, not every button may have a command programmed for it. In that case, nothing would be indicated.
5. Using the **DIRECT** buttons D-1 through D-8, PAGEs 1 through 4, up to 32 different specialized commands are available for each FUNCTION, up to a total of 320 specialized commands (32 direct commands times 10 functions). Note that for any particular function selector, not all 32 direct commands may be provided and/or named as supplied from the factory.
6. For example, the RC2000MKII is supplied from the factory with 3 pages of DIRECT commands for the LD (laser disc) function. To change pages, press the page direction ◀ or ▶ buttons [8]:

**Page 1: MODE:** Side A/B laser disc playback functions

**Page 2: L D:** Specialized laser disc functions

**Page 3: R E C:** Recording from laser disc to VCR functions

At this point, you may wish to put this guide aside temporarily, and begin using the RC2000MKII with your A/V system. If you already have any Marantz components, or Philips and/or other brands of components that use the RC-5 remote control language, you can begin controlling those components with the RC2000MKII right away. Take some time to become comfortable with the operation of the RC2000MKII. We think that its intuitive key pad layout and easy to read LCD window will permit you to quickly become familiar with its operation.

If you do not have any Marantz or other brands of components that use the Philips RC-5 remote control language, then you may wish to proceed to the next section, which will describe the steps necessary to "teach" your RC2000MKII remote codes from other components you may have in your system.

### LEARN mode:

The RC2000MKII has the ability to learn remote codes for just about any component in your A/V system. If the original component was supplied with an infrared remote control, its commands can be learned by the RC2000MKII. If you have another brand of laser disc player, for example, you can program the RC2000MKII with its codes. For example, we'll show you how to "teach" the RC2000MKII commands from another brand of laser disc player.

1. Using a sharp point (such as the tip of a paper clip), press the operation **MODE** button [1] each time you press the button. The mode within the LCD display, the LEARN indicator will begin blinking.
2. Place the laser disc player's supplied infrared remote controller so that its transmitter window (usually at the top) is facing the infrared sensor window of the RC2000MKII (at the bottom), about 5 cm (2 inches) apart.

3. Press the LD function button on the RC2000MKII.
4. Press the play button [5] on the RC2000MKII.
5. Press and hold the corresponding **PLAY** button on the laser disc player's remote transmitter until the "OK" indicator appears in the RC2000MKII LCD window (see Figure 2) or the beeps sounds emit (if the beep sound function is set).

Figure 2

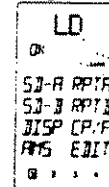

If the "AGAIN" indicator appears in the RC2000MKII LCD window, it means that for some reason the command was not properly learned. Repeat steps 3, 4 and 5 above.

In the unlikely event that an infrared command cannot be learned by the RC2000MKII, "NG" (no good) will appear in the LCD window, meaning that the command is not "learnable". The RC2000MKII has been tested for compatibility with a very wide range of infrared remote control frequencies and data word lengths, but in some very rare instances, it may not be possible to learn a particular remote control command.

Continue to "teach" the RC2000MKII the rest of the source transmitter's transport function commands, such as **STOP, PAUSE, NEXT, PREVIOUS, FAST FORWARD** and **REWIND**, by repeating steps 3, 4 and 5 above.

6. Proceed to learn the numeric "10 keys" from the source transmitter to the RC2000MKII's 10 key numeric pad [2] by repeating steps 3, 4 and 5 above.
7. For each additional function, such as TV, VCR, etc., repeat steps 3, 4 and 5 above. During the LEARN operation, if any button is not pressed within 1 minute, the RC2000MKII will revert back to the previous operating mode.
  - To make a function button learn a code, switch the input function then press the button again.
8. After memorizing all desired remote codes, press the operation mode button [1] with the tip of a paper clip, and select the USE mode. The LCD display window will continue to display the USE indicator, and all of the newly memorized codes will be available (see Figure 3).

Figure 3

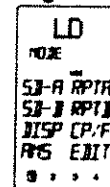

For any button for which a new code was not learned, the factory programmed RC-5 code will still transmit as usual.

### Note:

**POWER ON/OFF** [4] code can be learned regardless of the function button selection:

### Programming the DIRECT mode buttons [7]:

The following example will show how to memorize the SIDE-A function command of another brand of laser disc player into the D1 direct button.

1. Using a sharp point (such as the tip of a paper clip), press the operation **MODE** button [1] to switch the RC2000MKII to LEARN mode.
2. Place the laser disc player's supplied infrared remote controller so that its transmitter window is facing the infrared sensor window of the RC2000MKII about 5 cm (2 inches) apart.
3. Press the LD function button [9] on the RC2000MKII.
4. Using the direct function page keys ◀ and ▶ [8], set the direct function to Page 1. Press the D-1 button [7] on the RC2000MKII.



- Press and hold the corresponding SIDE-A button on the laser disc player's remote transmitter until the head of name blinks in the RC2000MKII LCD window or beep sounds emit. The RC2000MKII changes to the RENAME mode automatically as next step. A function name of the **DIRECT** function button is blinked, you can rename this blinking function name. You input the desired letter or number with the ten keypad. (See the table in step 3 of the next procedure to referce.) If you need not to rename, press the **OK** button or the other buttons except the ten keypad.
- Now, proceed to program the other commands from the laser disc player's remote transmitter to the other **DIRECT** function buttons (D2-D8). When you have "taught" all 8 direct functions for Page 1, press the page direction key **▶** [8] to go to Page 2, and you can program more direct function keys.
- After memorizing all codes to all **DIRECT** function buttons, press the operation **MODE** button [1] with the tip of a paper clip and return the RC2000MKII to the USE mode. Now, the newly memorized codes are usable from the RC2000MKII.

- Continuing along, re-write the remaining letters "V", "-", "5", "2", and "0". By pressing the cursor keys **◀** and **▶**, each character is confirmed in place. When you go to other **DIRECT** function pages by using the page function keys [8], characters in the previous page are also confirmed in place.  
The name re-writing operation must be done on a function by function basis, that is, re-write the names for all of the **LD** direct functions, then switch to another function such as VCR, and begin the re-writing process anew to re-name the **VCR** direct function commands.

**How to re-write the STATUS name:**

Using the same steps as outlined above, you can re-write the 9 character status name. During step 5 above, by pressing the up and down cursor keys [6] the left side of the status indicator begins blinking, and you can change its display according to the same method outlined above, using the 10 keypad character generator. Remember, to confirm each character change, use the cursor keys **◀** and **▶**. As above, when you change the direct function page by pressing the page direction keys [8], this will confirm the re-written characters in place as well for the page you just finished re-naming. You have up to 9 letters, numbers or other characters available for each status name.

**How to re-write the DIRECT function button names:**

You can change the name for each of the 8 direct function buttons by using the steps described above to change main function name and status name. Remember, each main function has 8 direct function buttons on each of the 4 pages, so you have up to 32 direct functions that can be re-named, if you wish, for each of the 10 main function selection buttons [9]. You have up to 4 characters available for each direct function button name.

After completing all re-writing of any of the names, press the **OK** button within the cursor keys [6], or switch to another function button (such as CD). If, during re-naming, a button has not been pressed for 1 minutes, the RC2000MKII will revert to the prior operating mode (USE) automatically.

If re-writing of all of the desired direct mode functions has been completed, use the pen tip to press the operation **MODE** button [1], and select the "USE" mode. Now, all of the re-written names are available for use.

**How to clear (erase) the memorized codes**

**(and any re-written names):**

The RC2000MKII has a high capacity RAM, which ordinarily will allow the learning of several hundred remote codes (and their associated new names, if desired). However, due to the fact that some remote codes occupy more memory space than others, it is possible that the available RAM fills up completely, and the "FULL" indicator appears in the LCD window. In this case, it will not be possible to learn any new remote codes without first deleting some or all of the previously learned remote codes and/or re-written names. There are 4 ways to erase learned remote codes from memory:

- Erasing by button(s)
- Erasing by **DIRECT** button(s)
- Erasing by function(s)
- Erasing all memory contents (complete erasure)
- Note that the factory-programmed RC-5 codes are not stored in RAM, and are therefore not erasable.

For any of these memory erasure options, you must first set the RC2000MKII to LEARN mode.

**Erasing the memory assigned to a particular button:**

Press and hold the **CLEAR** button [14] and press the button that you wish to erase 2 times. The code previously learned by that button will be erased, and will then be either empty, or the original factory provided RC-5 code will re-appear in its place.

If you wish, you can re-write the names for each function name, status name, and the direct function command names as follows:

For our example, you can change the LCD display window indication from "LD" to "LV-520" (which is the model number for a Marantz laser disc player). Remember, you can re-name a function selector button with a new name of up to six characters of letters and numbers in any combination.

- Using the tip of a paper clip, press the operation **MODE** button [1] until the NAME indicator appears and begins to blink in the LCD window.
- Choose a button that you wish to re-name, in this case, press the "**LD**" function button [9]. In the LCD window, the first character of the six function character display indicators starts blinking "A", which is the first letter of the alphabet.
- Choose the desired letter or number by pressing the 10 keypad buttons [12]. Each 10 keypad button has 4 characters attached to it as follows:

10 key pad button	Press, press again, press again, etc.
1	1 → A → B → C → 1 → .....
2	2 → D → E → F → 2 → .....
3	3 → G → H → I → 3 → .....
4	4 → J → K → L → 4 → .....
5	5 → M → N → O → 5 → .....
6	6 → P → Q → R → 6 → .....
7	7 → S → T → U → 7 → .....
8	8 → V → W → X → 8 → .....
9	9 → Y → Z → / → 9 → .....
0	0 → + → - → SPACE → , → ' → 0 .....

So, in the above example, by pressing the 10 keypad number 4 four times, you get the letter "L" to appear in the display (see Figure 4).

**Figure 4**

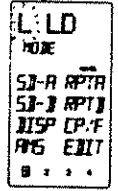

- You use the cursor buttons **◀** and **▶** [16] to move to the next character in the display. By pressing the right cursor button **▶**, the letter "L" is confirmed in the first character space in the LCD window and the next character position begins blinking. If you wish to erase a previously memorized character, position the cursor over the character and put the SPACE character in its place (the SPACE character is ten key pad number 0 pressed four times, from the above character chart).

**Erasing the memory assigned to a DIRECT buttons:**

All codes and names which were previously memorized for each of the functions (such as TV, LD, VCR, etc.) in pages can be erased. Press and hold the **CLEAR** button [14] and press the < or > button [6] 2 times. You will see the "DIR- CLR?" (direct button - clear?) indication in the LCD window (see Figure 5). If you wish to go ahead and clear all of the memorized codes for that **DIRECT** button (8 buttons x 4), press the **OK** button

Figure 5

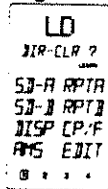

**Erasing the memory assigned to each function command set:**

All codes and names which were previously memorized for each of the functions (such as TV, LD, VCR, etc.) can be erased. Press and hold the **CLEAR** button [14], and press the function button that you want to erase 2 times. You will see the "FNC - CLR?" (function - clear?) indication in the LCD window (see Figure 6).

Figure 6

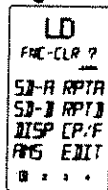

If you wish to go ahead and clear all of the memorized codes for that function button, press the **OK** button within the cursor keys [16]. After clearing the memory contents for that function, the RC2000MKII will restore any factory programmed RC-5 codes for the function, if any, or will simply be empty.

If you want to cancel the memory clear operation, do not press the "OK" button, but instead simply touch any other button. When you clear all the commands associated with a function button, all of the learned direct function commands (D-1 through D-8, pages 1 through 4) and control buttons, ten keypad, etc are cleared as well.

**Complete erasure:**

While holding the **CLEAR** button [14] depressed, press both of the **ON** and **OFF POWER** buttons [4] simultaneously; "ALL-CLR?" is displayed on the LCD window (see Figure 7).

Figure 7

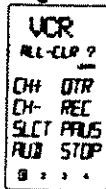

If you wish to finalize the complete erasure process, press the **OK** button within the cursor keys [16]. If you do not wish to proceed with the complete erasure process, simply press any key other than **OK**. Remember, the RC-5 codes as supplied from the factory cannot be erased from memory, but they can be replaced with different codes as you wish.

- By now, you have learned how to memorize codes from other brands of components, including changing the various function, status, and direct function names.

Before continuing on to the more advanced RC2000MKII programming techniques, you may wish to continue "teaching" the RC2000MKII remote control with any or all other commands for other components in your system. When you feel you've transferred as many different commands from other components into the RC2000MKII as you'd like, and possibly changed some or all of their names as well, then feel free to proceed to the next section.

- The all-clear operation takes about 15 seconds after the **OK** button is pressed.

**ADVANCED PROGRAMMING TECHNIQUES**

**Macro mode:**

The word "macro" is used to describe a series of specific steps carried out in sequence. For example, a word processing program can use macros to carry out common repetitive typing tasks. During the day to day operation of an A/V system, you might find yourself pressing the same combination of remote control buttons often.

The RC2000MKII features the ability to "learn" a sequence of infrared commands, and "assign" that sequence to a single button, called a **MACRO** button [6]. Then, when you want to achieve a specific result, you can activate a macro button to begin sending out a series of commands. For example, suppose you wish to activate your A/V system, and watch a movie on laser disc. A single macro button could send out the following commands in this suggested sequence:

- Turn the main amp power on, then turn the TV power on, then switch the TV to the AUX video input, then change the amp to the laser disc (LD) input, then turn the LD player power on, then activate the LD play command, then set the amp surround sound mode to Dolby Pro Logic.

The above 7 step sequence can be programmed into a single macro button, and can be used anytime you want to watch a LD movie. Other macro functions could be used for CD listening, or any other sequence of steps that you regularly perform while controlling your A/V system. Macro commands are available when the RC2000MKII is set USE mode.

To program a macro, first identify which commands you wish to memorize, and note if any commands must be in a specific order (for example, before you can activate an amplifier's surround mode, the amp must first be turned on).

1. Press the **MACRO** [2] operation mode button with the tip of a paper clip. Within the LCD window, the **MACRO** indication appears, then the **LEARN** indicator starts blinking (see Figure 8).

Figure 8

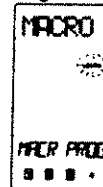

If a macro was previously programmed, one or more of the numeric indicators at the bottom of the LCD window will appear with a box around it.

2. Press macro button 1 [6] to begin memorizing the various codes. In the LCD display window the indicator "M1-00" appears in the status line [6] (see Figure 9).

Figure 9

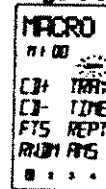

The "M1-00" indication signifies Macro number 1, no steps yet programmed. As each macro step is programmed, the "00" indicator will advance by one digit-"01", "02", etc. After the first macro step is programmed, two additional digits (with a decimal in between) become visible at the end of the status line, showing the timing value for each step (see Figure 10).

Figure 10

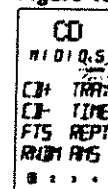

3. Press the command buttons in the desired sequence. When you press a command button to be learned into the macro sequence, its name will appear within the LCD window. Every time you press another remote command, the macro step number increases one by one.
4. It is possible during macro programming to adjust the timing of the interval between several macro steps. Using the cursor keys **[6]**, the interval between macro playback steps can be increased or decreased in 1/2 second steps, over the range beginning at 1/2 second up to 10 seconds. For example, when the indicator shows "0.5 SEC", if you press the ◀ direction key, the interval time would change to 10 seconds, then with another press of the ◀ direction key, it would change to 9.5 seconds, etc. Use the ▶ direction key to increase the interval time, and use the ◀ direction key to decrease the interval time. Some equipment may not be able to receive infrared commands in one-half second steps. If after programming a macro you find that the sequence was not properly carried out, you may wish to experiment with different sequence timings to obtain the correct operation results, by using the adjustment method described above. Within each macro button, up to 20 steps can be memorized. In the event that you wish to memorize more than 20 steps per macro, then press another **MACRO2** button **[6]**, and follow the above operations. A maximum of 80 steps can be programmed this way. However, you will probably find that 20 steps is more than enough to carry out even the most complex macro instructions to achieve a specific home theater operating result.

**Note:**

To memorize the cursor button **[6]**, press and hold the **LIGHTING** button **[20]** before pressing the cursor button.

**When programming macro steps, note that the following buttons would not normally be included in a macro sequence, and are therefore not available for inclusion in a macro:**

**MODE [1], MACRO [2], CLONE [3], PAGE [8], VOLUME [11], MEMO [13], CLEAR [14] and LIGHTING [20].**

To check to see which **MACRO** buttons **[6]** have been programmed with macros, at the beginning of the macro learning sequence the four numerical (1 through 4) indicators at the bottom of the LCD window will show a box around the number for each **MACRO** button that already has a macro assigned to it (see Figure 11, which shows that only **MACRO** button number 1 has a macro assigned to it).

**Figure 11**

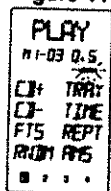

In the event that you wish to revise a programmed macro sequence, search the step number you wish to change by using the cursor button ▲ and ▼ **[6]**, and then re-enter the new command. If you memorized different commands than have already been programmed, then the previous macro sequence will be erased and re-written over with the new sequence. To add the new command, press the **MEMO** button at your desired point. To delete the sequence, press the **CLEAR** button at your desired point.

During macro programming, if a button is not pressed within 1 minutes, the mode will automatically revert to the original mode (USE).

When you have completed the macro programming sequence, press the **MACRO [2]** operation button with the the tip of a paper clip. The "END" indication appears in the LCD display window. When you release the **MACRO** button, all indications will revert to the initial status. There is one more important point to note about programming a macro sequence. During a macro sequence, you may include more than one function selection button to access some transport and/or other commands. Depending on the macro sequence, this might result in the

amplifier or receiver's function selection to be inadvertently changed as well when the macro is played back. The RC2000MKII has a special feature to prevent this from occurring, allowing you to access the special commands available under each RC2000MKII function button during a macro playback sequence, while at the same time prevent the amplifier or receiver from constantly switching its input source back and forth at the same time.

During the programming sequence, just remember that if you wish to activate a specific input selector on your amplifier or receiver, make sure that you press the desired input selection button **FIRST**. Subsequent function button selections can be incorporated in the macro sequence, but on playback, the RC2000MKII will only send out a function selection infrared command to the amplifier or receiver based upon the first function command used in the macro sequence.

For example, you may wish to have a macro sequence which activates the laser disc player input on your amplifier or receiver, and then have additional commands in the sequence to instruct your TV set to switch to an external video source to receive the laser disc video signal. During the macro programming, make sure that you press the **LD** function selector button **BEFORE** you press any of the other function selector buttons in the sequence. You can then include any of the TV commands by pressing the **TV** function selector button, later in the sequence. When this macro is next used (played back), the RC2000MKII will send out the command to change the amplifier or receiver's input selector to laser disc input (since its function selector button was the first one programmed into that macro sequence), and will not subsequently change the amplifier or receiver's input to TV (but will send out any special TV commands that you included in the macro sequence).

**Programming a macro under a function selector key:**

If you wish, you can also program a macro that can be activated by pressing one of the function selector **[9]** keys. The programming steps are similar to the steps outlined for programming a macro number button **[6]**. The following example shows how to program a macro under the **LD** (laser disc) function selector **[9]**:

(activate the main amplifier's power on, switch the source to laser disc, switch the amplifier's surround mode to PRO LOGIC, switch on the television, switch to the television's AUX video input, power up the laser disc player, and begin laser disc playback)

1. Press the **MACRO [2]** operation mode button with the tip of a paper clip.
2. Press the **LD** function button **[9]**.
3. Press the following buttons:  
POWER ON, LD, AMP, direct function D-5 (PRO LOGIC selector) in page 1, TV\*, SOURCE ON, direct function D-4 (VIDEO input selector) in page 1, LD\*, SOURCE ON, and PLAY.
4. Press the **MACRO [2]** button with the tip of a paper clip. The RC2000MKII will revert to the normal mode and save the macro under the **LD** function button.
5. To execute the new macro sequence, press twice and hold the **LD** function selector button for 3 seconds.

**Using the macro function(s) you have programmed:**

1. Press the desired **MACRO** [6] button. The corresponding macro number will appear at the bottom of the display window. OR if a macro has been programmed under a function button, press the **MACRO** [6] button twice and hold that function button for 3 seconds. The LCD display window will indicate the macro number in the LCD window (see Figure 12), or if a macro is programmed under a function key, the status line will display the macro under function buttons as follows:

Figure 12

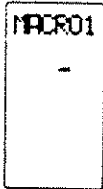

Macro under function button:	Status line shows:
LD	"LD" as the first 2 characters in the line
TV	"TV" as the first 2 characters in the line
VCR	"VC" as the first 2 characters in the line
DSS/MD	"DS" as the first 2 characters in the line
AUX	"AX" as the first 2 characters in the line
TUNER	"TU" as the first 2 characters in the line
CD	"CD" as the first 2 characters in the line
TAPE	"TP" as the first 2 characters in the line
DVD	"DV" as the first 2 characters in the line
AMP	"AP" as the first 2 characters in the line

2. The macro sequence will begin, and the remote control codes will be sent from the RC2000MKII and the display will show the names of the transmitted codes.
3. When the macro transmit sequence has ended, the RC2000MKII will return to the same mode before the macro function was initiated.

**Now that we've explained how to program a macro, perhaps the following suggested example can help you become more familiar with the process:**

(to switch the RC2000MKII to CD, then initiate CD playback, and go to track 3 on the CD)

1. Press the **MACRO** [2] operation mode button with the tip of a paper clip.
2. Press one of the **MACRO** buttons (1 through 4).
3. Press the following buttons:
  - CD function selector, then numeric key pad 3, then transport control key pad PLAY key. (see Figures 13, 14, and 15)

Figure 13

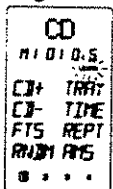

Figure 14

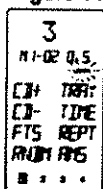
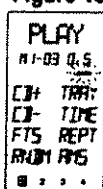

Figure 15



Note that this sequence will operate a Marantz CD player (or any other CD player equipped with the RC-5 remote control language). If you have another brand of CD player, you may wish to check its owner's manual to see if direct track selection is possible via remote, or if the macro sequence needs to be adjusted according to the programming steps required by your CD player.

4. Press the **MACRO** [2] button with the tip of a paper clip. The RC2000MKII will revert to the normal mode (see Figure 16).

Figure 16



5. Press the **MACRO** [6] button you desired. RC2000MKII will transmit the programmed code. (see Figures 17, 18, and 19)

Figure 17

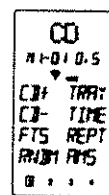

Figure 18

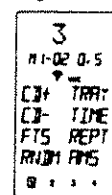

Figure 19



**Note:**

If you would like to cancel the MACRO function, press the **STOP** [15] button.

**Now, we'll show you another macro programming example, with a more sophisticated sequence:**

(activate the main amplifier's power on, switch the source to laser disc, switch the amplifier's surround mode to PRO LOGIC, switch on the television, switch to the television's AUX video input, power up the laser disc player, and begin laser disc playback).

1. Press the **MACRO** [2] operation mode button with the tip of a paper clip.
2. Press one of the **MACRO** buttons (1 through 4).
3. Press the following buttons: POWER ON, LD, AMP, direct function D-2 (PRO LOGIC mode) on page 2, TV\*, SOURCE ON, direct function D-4 (VIDEO input selector), LD\*, SOURCE ON, and PLAY.
4. Press the **MACRO** [2] button with the tip of a paper clip. The RC2000MKII will revert to the normal mode.
5. To execute the new macro sequence, press the appropriate **MACRO** button (1 through 4) that you chose at the beginning of the above programming sequence.
  - Note that the function selector buttons TV and LD marked with an asterisk (\*) in this macro sequence do not actually send out infrared codes, but simply change over the RC2000MKII's programmed memory code banks for those respective functions.

If you would like to clear the MACRO programmed sequence(s), press and hold the **CLEAR** [16] button and simultaneously press the appropriate **MACRO** button (1 through 4) or function button. "MR1-CLR?" (macro 1-clear?) appears in the LCD window. Release the buttons, and then press the **OK** button (within the cursor control buttons), and the macro is erased. If you do not wish to erase the macro, simply press any other button (but not the **OK** button).

**CLONE mode:**

Duplicating the memory contents of one RC2000MKII to another RC2000MKII.

For a complete home theater system, with numerous components from many different manufacturers, you may find that you have stored dozens, even hundreds of different codes, along with specialized names, macros, etc. We have provided a very quick and simple procedure that allows you to download the entire customized memory contents of one RC2000MKII remote control into another, fresh RC2000MKII.

**To "clone" (duplicate) the memory contents of one RC2000MKII into another RC2000MKII, please follow these steps:**

1. Place the source RC2000MKII (the one with all of the customized commands, names, macros, macro sequences, and the like) with its infrared transmitter window **22** facing the infrared sensor **23** of another "fresh" RC2000MKII (5 cm. or 2 inches apart).
2. Press the **CLONE** button **3** of the source RC2000MKII with the tip of a paper clip, and select "CLONE TX" (clone transmit) mode (see Figure 20).

Figure 20

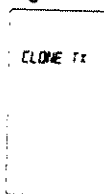

3. Press the **CLONE** button **3** of the learning (receiving) RC2000MKII with the tip of a paper clip or a similar object, and select "CLONE RX" (clone receive mode). Then press the **PLAY** button **15**.

Figure 21

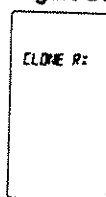

4. Press the source RC2000MKII's transport control **PLAY** **15** button to begin the infrared data transmission sequence. If you wish to duplicate only 1 to 8 function's memory, press function button(s) you wish before pressing the PLAY button. Now the "LEARN" indicator of receiving RC2000MKII starts to blink. (see Figure 23)

Figure 22

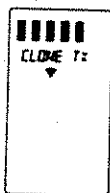
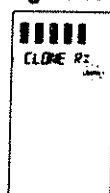

Figure 23



After all bars are lit up on both displays, "TX OK" (transmission OK) will appear in the source RC2000MKII's LCD window, and "RX OK" (reception OK) will appear in the "cloned" RC2000MKII's LCD window, confirming the end of the copying process (see Figures 24 and 25).

Figure 24

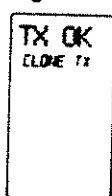
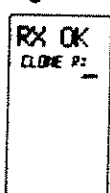

Figure 25



Please be sure that, during the copying process, neither RC2000MKII is physically disturbed (ideally, they should be placed on a table or other surface, and not hand-held during the copying process). If, for some reason, the copying process was interrupted, the "clone" RC2000MKII's LCD display window will indicate "RX NG" (reception no good). Simply begin the clone process anew by repeating the above steps.

**Note:**

The cloning is available between the same remote control unit series only therefore the RC2000MKII cannot be cloned by RC2000.

5. If the source RC2000MKII's memory contents are at or near full capacity, the copying process will take about 3 minutes. After completion of the copying (cloning) process, press the **CLONE** button **3** on both RC2000MKII's with the tip of a paper clip, and select the OFF mode. Then, you'll have two identically programmed RC2000MKII remotes, one of which can again be used as your system's primary remote control, and you'll have the added confidence of knowing that in the event of inadvertent programming (or memory contents being cleared somehow), you can simply retrieve the "backup" RC2000MKII that you've safely tucked away, and within minutes restore the programming contents of the original RC2000MKII with your customized configuration.

**OTHER FUNCTIONS**

The Marantz RC2000MKII includes the ability to tailor the lighting features according to your preferences. As supplied from the factory, the RC2000MKII has a lighting features (and lighting timings):

1. The lighting time is set at the factory for a period of 2 seconds which you can change if you prefer a different lighting time. If you wish to maximize battery life, you can defeat the lighting function entirely. There is also a lighting button **20**, so that in any light situations, you can activate the backlighting feature. The lighting time in this case is set at the factory for a period of 2 seconds, which you can also change. If you wish to conserve battery power, you can de-activate the lighting function entirely.

**RC-5 Shipped destination:**

As mentioned earlier in this guide, the RC2000MKII is provided with many commands from the factory with infrared codes conforming to the Philips RC-5 remote control language (used by Marantz, Philips, and some other companies). We have provided two different RC-5 command code sets in the RC2000MKII, according to the local requirements of different markets and the different types of remote control codes used in those markets. One code-set is for North American (US) users, while the other code set is for REST users. Your RC2000MKII has been set at the factory for US (United States) codes. It can be easily changed, if you wish.

**Set-Up:**

To change the lighting time(s), or the destination setting, please follow these steps:

- Select the SETUP mode, by holding the **MEMO** button **13** and at the same time press the **OK** button within the cursor keys **16**. (see Figures 26 and 27)

Figure 26

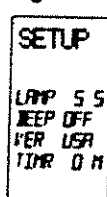
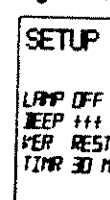

Figure 27



**LAMP - Lighting function ON or OFF and TIME**

Press the D-5 direct function button, and you can then set the time (in seconds) directly using the numeric key pad [12] buttons. A time figure consisting of only 1 digit can be input by pressing the figure then waiting for 2 seconds or input "0" before entering a desired digit. You can set time in the range from 0 up to 60 seconds (More time would use up more battery life than fewer seconds). "2" is set when shipped from the factory. You can set "OFF" to input "0".

**BEEP sound**

The beep sounds when press any buttons.

The beep sound level can be set to decrease or increase by pressing the D-6 button. The display indicates "+" indication and the beeps are sounded by pressing the D-6 button. The "+" indication is followed the "+" indication as the beep sound is increased; + → ++ → +++ → ++++

When the "++++" appears, this is the maximum. If D-6 button is pressed once more, it will reset to the minimum level (+).

"J" is indicated in LCD window when the beep sound is set.

**Note:**

The beep sound is different between the function buttons and other buttons.

**VER**

Press the D-7 direct function button to switch between US to REST.

If you need to change this function, we recommend that you make the change before you begin "learning" any new infrared codes for other brands of equipment in your system.

**Note:**

The name of the **DIRECT** buttons will be erased if the USA/REST version is pressed.

**Battery life:**

- Battery life will vary from user to user, if the remote is used constantly or only occasionally, including the amount of backlighting usage. We feel that you can expect the batteries to last about 4 months, based upon 15 remote control operations per day (every day), and 3 lighting operations per day (every day). If the remote is used more often, and if the lighting times are set to longer times than the factory settings, then the battery life may be shortened somewhat.

- As explained earlier in the guide, the RC2000MKII's sophisticated battery conservation system will advise you long before the battery power is fully exhausted, and will further warn you to replace the batteries by simply becoming inoperative at a certain point. The customized memory contents and user-adjusted settings will still be retained in memory. When you install a fresh set of batteries, the memory contents are protected always, because the RC2000MKII use the non-volatile memory. Alkaline (and the newer lithium) types are recommended for longest battery life.

As you become more familiar over time with how you are using the RC2000MKII in your AV system, you may wish to consider reducing the lighting time(s) if possible, as this can help to extend the battery life.

**Adjustment of the LCD contrast**

- The LCD contrast can be adjusted as follows;

Set SETUP mode to the RC2000MKII by pressing the MEMO and OK button. Press the VOL+ to increase the LCD contrast. Press the VOL - to decrease the LCD contrast. Press the OK button to end this setting and return the original operation.

**DIRECT COMMAND FUNCTIONS LISTING**

Within the RC2000MKII LCD window, each of the 8 Direct Function buttons has 4 character label attached for pre-programmed remote commands. These commands can be used with various Marantz A/V components, or other components using the Philips RC-5 remote control language

You can easily replace the factory-supplied remote command codes with different codes from other brands of equipment. Most functions that are supplied apply to a wide variety of equipment from many companies. The following list shows the remote code assignments for the direct function buttons, for each of the 10 main function selector buttons, as supplied from the factory. You can add or replace function commands, including re-naming them if you wish, in order to customize the RC2000MKII for your own particular selection of A/V components.

AMP	1 MODE-1	1 AC-3 2 RF 3 OPT 4 COAX 5 P/L 6 6-CH 7 2-CH 8 NITE	selects Dolby Digital (AC-3) decoding selects Dolby Digital RF input selects optical digital input selects coaxial digital input Dolby Pro Logic decoding activates 6 channel setup Stereo (no surround decoding) selects NIGHT mode
	2 MODE-2	1 AC-3 2 P/L 3 3-ST 4 MOV 5 THX 6 MTRX 7 HALL 8 2-CH	selects Dolby Digital (AC-3) decoding Dolby Pro Logic decoding Dolby 3-stereo decoding Movie surround sound THX Cinema decoding Matrix surround sound Hall surround sound Stereo (no surround decoding)
	3 SETUP	1 TEST 2 DLAY 3 R-EQ 4 ATT 5 CH+ 6 LVL+ 7 LVL- 8 MLTI	activates test tone increases delay time activates RE-EQ function activates ATT function next channel (up) increases channel level volume decreases channel level volume activates multi-room mode
	4 PROCESSOR	1 RF 2 OPT 3 COAX 4 BYP 5 VOL+ 6 VOL- 7 SLEP 8 6-CH	selects Dolby Digital RF input selects optical digital input selects coaxial digital input bypasses Dolby Digital decoding increases Dolby Digital volume decreases Dolby Digital volume activates amplifier's sleep timer activates 6 channel setup
TUNER	1 BAND	1 FM 2 AM 3 LW 4 BAND 5 MODE 6 TIME 7 F/P 8 SCAN	FM band AM/MW band long wave band selects radio band mono/stereo/muting mode selector time display frequency or preset channel display programmed preset channel scan

TUNER	2 REC	1 TP-1 2 REC 3 PAUS 4 STOP 5 TP-2 6 REC 7 PAUS 8 STOP	commands for Tape 1 control (NO output) record pause stop commands for Tape 2 control (NO output) record pause stop
	3 RDS (for REST only)	1 STM 2 AF 3 PTY 4 DISP 5 6 7 8 DWR	selects station mode selects AF function selects PTY function selects display function   selects DSR wave range
CD	1 MODE	1 CD+ 2 CD - 3 FTS 4 RNDM 5 TRAY 6 TIME 7 REPT 8 AMS	CD changer next disc CD changer previous disc favorite track selection random (shuffle) play function tray open/close time display elapsed/remain/total repeat function automatic music scan
	2 CHANGER1	1 CD1 2 CD2 3 CD3 4 CD4 5 CD5 6 EDIT 7 RCL 8 CNCL	selects Disc 1 selects Disc 2 selects Disc 3 selects Disc 4 selects Disc 5 tape edit function recall track programming cancel track programming
	3 CHANGER2	1 UNIT 2 DISC 3 TR 4 CATG 5 MODE 6 TITL 7 T-S 8 ENT	selects unit No. selects disc No. selects track No. selects category selects mode selects function title mode selects title search selects enter
	4 REC	1 TAPE 2 REC 3 PAUS 4 STOP 5 MD 6 REC 7 PAUS 8 STOP	commands for Tape control (no output) record pause stop commands for MD control (no output) record pause stop
TAPE	1 MODE	1 TP-A	selects tape deck A

TAPE	1 MODE	2 TP-B 3 DIR 4 TIME 5 TRAY 6 AMS 7 REC 8 PAUS	selects tape deck B auto-reverse direction time display tray open/close automatic music scan record pause
	DVD	1 MODE1       2 MODE2	1 ANGL 2 TITL 3 SUBT 4 MENU 5 TRAY 6 SUND 7 SET 8 RTN  1 SLOW 2 LPLY 3 RNDM 4 RPT 5 A/B 6 +10 7 T/C 8 ZOOM
DVD	1 MODE1	1 ANGL 2 TITL 3 SUBT 4 MENU 5 TRAY 6 SUND 7 SET 8 RTN	selects angle selects title menu selects sub title selects main menu tray open/close selects languages selects setup menu return to menu
	2 MODE2	1 SLOW 2 LPLY 3 RNDM 4 RPT 5 A/B 6 +10 7 T/C 8 ZOOM	slow forward last play function shuffle play function repeat modes repeat A to B digit entry +10 title and chapter zoom mode on/off
	3 KARAOKE	1 ONOF 2 ONCE 3 MELO 4 VOCL 5 MODE 6 3-D 7 VSLF 8 VRLR	karaoke on/off once play again melody play vocal support play karaoke modes surround processor on/off very slow forward very slow reverse
DVD	4 REC	1 VCR1 2 REC 3 PAUS 4 STOP 5 MD 6 REC 7 PAUS 8 STOP	selects VCR1 control (no output) record pause stop selects MD control (no output) record pause stop
	LD	1 MODE       2 LD	1 SD-A 2 SD-B 3 DISP 4 AMS 5 RPTA 6 RPTB 7 CP/F 8 EDIT  1 MSP+ 2 MSP- 3 FRM+ 4 FRM-
LD	1 MODE	1 SD-A 2 SD-B 3 DISP 4 AMS 5 RPTA 6 RPTB 7 CP/F 8 EDIT	side A side B display on/off automatic music scan Repeat A start point Repeat B stop point selects chapter or frame activate tape edit function
	2 LD	1 MSP+ 2 MSP- 3 FRM+ 4 FRM-	CAV multi-speed increase CAV multi-speed decrease frame advance frame reverse

LD	2 LD	5 MS-F 6 MS-R 7 AUD 8 D/CX	CAV multi-speed forward direction CAV multi-speed reverse direction Stereo, left only, right only channel digital audio, analog audio, CX NR
	3 REC	1 VCR1  2 REC 3 PAUS 4 STOP 5 VCR2  6 REC 7 PAUS 8 STOP	commands for VCR 1 control (NO output) record pause stop commands for VCR 2 control (NO output) record pause stop
	4 VCD (for REST only)	1 PBC 2 KARA 3 IDX+ 4 IDX- 5 SEL 6 RTN 7 NEXT 8 PREV	selects play back control selects karaoke index up index down play or select audio stop or select return track next track previous
	1 MODE	1 A/CH 2 100S 3 VID 4 INFO 5 VOL+ 6 VOL- 7 MUTE 8	alternate channel 100's video information increases TV volume decreases TV volume mute sound on/off
TV	2 MODE/MENU	1 S-PI 2 S-SO 3 S-CH 4 5 MENU 6 ADV 7 STAT 8	smart picture smart sound smart channel  menu advance status
	3 PIP1	1 PIP 2 SWAP 3 FREZ 4 POSI 5 SIZE 6 STRO 7 PREV 8 RPLY	PIP on/off PIP swap PIP freeze PIP position PIP size PIP strobe PIP preview PIP instant replay
	4 TV TXT	1 CLR 2 SLOW 3 4 5 VCR1	PIP clear PIP slow motion
	1 MODE	1 A/CH 2 100S 3 VID 4 INFO 5 VOL+ 6 VOL- 7 MUTE 8	alternate channel 100's video information increases TV volume decreases TV volume mute sound on/off

TV	4 TV TXT	6 REC 7 PAUS 8 STOP	record pause stop
TV	1 MODE (for REST only)	1 CH + 2 CH - 3 CH-C 4 VID 5 VOL+ 6 VOL- 7 MUTE 8 OSD	next channel (up) previous channel (down) channel call external (aux) video input increases TV volume decreases TV volume mute sound on/off on screen display on/off
	2 MENU/CBL (for REST only)	1 MENU 2 SLP 3 CBL + 4 CBL - 5 ADV 6 STAT 7 M-UP 8 M-DN	activate menu activate sleep timer cable tuning next channel cable tuning previous channel advance to next menu page show current status Menu up (next) Menu down (previous)
	3 REC (for REST only)	1 VCR1 2 REC 3 PAUS 4 STOP 5 VCR2  6 REC 7 PAUS 8 STOP	commands for VCR 1 control record pause stop commands for VCR 2 control (NO output) record pause stop
	4 TV TXT (for REST only)	1 T/PG 2 HOLD 3 ENLG 4 RVL 5 CNCL 6 PG+ 7 PG- 8 ENT	switches time display activates page hold selects large of text page selects display of text page activates cancel picture increases page decreases page enter the next page
VCR	1 MODE	1 CH+ 2 CH- 3 SLCT 4 AUD 5 OTR 6 REC 7 PAUS 8 STOP	next channel (up) previous channel (down) select TV or VCR audio track selector one touch recording record pause stop
	2 PLAY MODE	1 2XPL 2 SLOW 3 STIL 4 5 SKIP 6 VIS+ 7 VIS-	twice normal playback speed slower than normal playback speed still frame  skip to next program marker VHS index search next VHS index search previous



VCR	2 PLAY MODE	8	
	3 MENU	1 MENU 2 STAT 3 CLR 4 GOTO 5 PLUS 6 7 8	activate menu show current status clear programming go to next item video PLUS
	1 DSS (for USA only)	1 DISP 2 PREV 3 CH+ 4 CH- 5 FAV 6 ALT 7 FTCH 8 ANT	brings up on screen channel marker goes to previously selected channel next channel previous channel favorite users and channel lists alternate audio channel, languages brings up on screen channel logos selects broadcast or cable antenna
	2 MODE	1 CH+ 2 CH- 3 SLCT 4 AUD 5 OTR 6 REC 7 PAUS 8 STOP	next channel previous channel select TV or VCR audio track selector one touch recording record pause stop
	3 PLAY MODE	1 2XPL 2 SLOW 3 STIL 4 5 SKIP 6 VIS+ 7 VIS- 8	two times play speed slow speed play still frame  skip to next program VHS index search next VHS index search previous
	4 MENU	1 MENU 2 STAT 3 CLR 4 GOTO 5 6 7 8	activate menu show current status clear programming go to next item
AUX	1 REC	1 VCR1 2 REC 3 PAUS 4 STOP 5 VCR2 6 REC 7 PAUS 8 STOP	commands for VCR 1 control (NO output) record pause stop commands for VCR 2 control (NO output) record pause stop

AUX	2 VCD/PHI 1 (for REST only)	1 CD+ 2 CD- 3 OSD 4 SCAN 5 A/B 6 SLOW 7 8	selects disc up selects disc down OSD on/off selects time search repeat A to B slow forward
	3 VCD/PHI 2 (for REST only)	1 PBC 2 KARA 3 IND+ 4 IND- 5 SEL 6 RTN 7 NEXT 8 PREV	selects play back control selects karaoke program selects video index up selects video index down selects in PBC returns in PBC next previous
	4 VCD/PHI 3 (for REST only)	1 CD+ 2 SHUT 3 OVEW 4 RESM 5 CHAN 6 FADR 7 8	selects disc up selects shutter function selects digest function selects last paly function selects channel selects MPX/vocal fader
MD (for REST only)	1 MODE 1	1 MD-A 2 MD-B 3 RPT 4 DISP 5 EJECT 6 AMS 7 RNDM 8 LP	select MD A select MD B select repeat modes select display modes eject automatic music scan randam diaplay selects SP/LP mode
	2 EDIT	1 EDIT 2 CHAR 3 DEL 4 ENT 5 AMRK 6 SYNC 7 PROG 8	selects edit mode selects character mode selects delete selects enter selects auto marker syncro REC selects program mode
	3 REC	1 MD 2 RECP 3 PAUS 4 STOP 5 TAPE 6 REC 7 PAUS 8 STOP	command MD (no output) REC-pause pause stop command tape (no output) record pause stop

## OPERATION OF REMOTE CONTROL UNIT

### 1. Remote control

The distance between the transmitter of the remote control unit and the IR SENSOR of the SR780 should be less than about 5 meters. If the transmitter is pointed to a direction other than the IR SENSOR or if there is an obstacle between them, remote control may not be possible.

#### Remote-controllable range

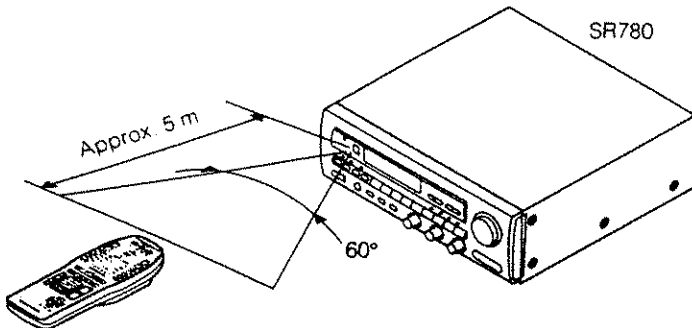

Remote control unit (RC2000MKII)

### 2. Loading batteries

The life of the batteries used with the remote control unit is about 4 month with normal use. Also be sure to replace batteries earlier when you notice that they are getting weak.

#### (1) Remove the back cover.

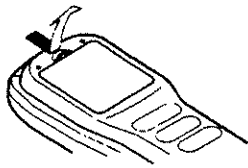

#### (2) Insert batteries (AA type) with correct (+) and (-) polarity.

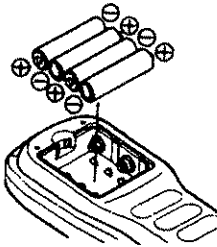

#### (3) Close until it clicks.

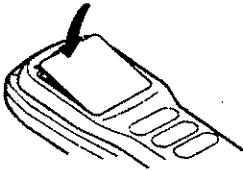

### 3. Receiving the remote control codes

The RC2000MKII can learn most of the remote control codes from various equipment, it learns the full word length of the code it is receiving.

Due to the sensitivity of the receiving LED the RC2000MKII may also "learn" noise from fluorescent lights, etc. which can quickly fill up the memory of the RC2000MKII.

In order to maximize the memory capacity of the RC2000MKII please pay close attention to the following:

#### (1) Aim the transmitting remote control at a direct line of the sight to the RC2000MKII remote receiver eye.

#### (2) Keep 2 inches between transmitting remote and the RC2000MKII receiving eye.

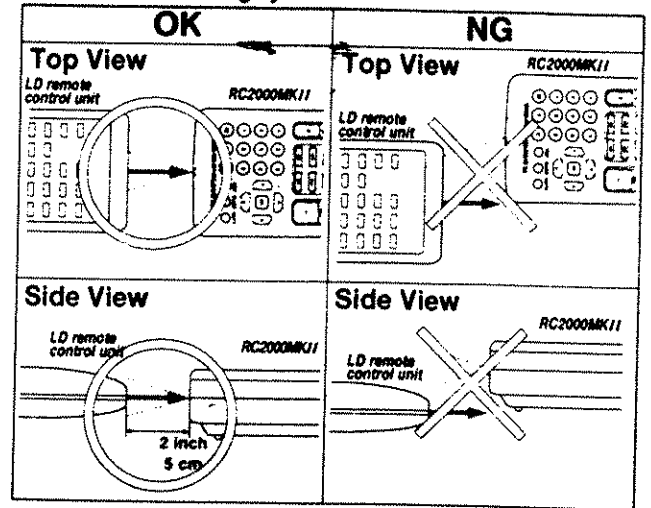

## ON-SCREEN DISPLAY

The on-screen display, which can be activated by Main unit or remote, appears on the TV screen to show the current setting status of the SR780.

1. When the OSD button is pressed, the current setting (①-⑥) are displayed on the TV monitor. The on-screen display can be turned off by pressing the button again. It also disappears automatically in about 10 seconds after the button is pressed.

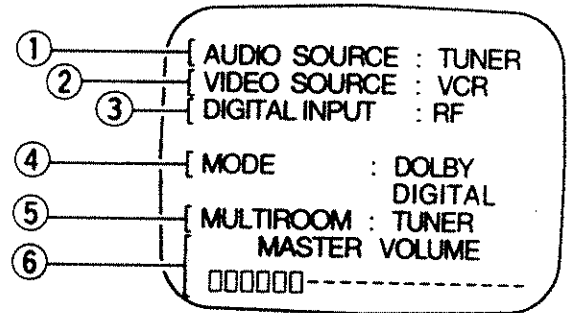

#### ① AUDIO SOURCE:

Displays the current audio source being selected with the function selector such as **TUNER, CD, TAPE, DSS/TV, LD, DVD, VCR** or **AUX**. The selected source name is displayed in void characters.

#### ② VIDEO SOURCE:

Displays the current video source being selected with the function selector such as **DSS/TV, LD, DVD, VCR** or **AUX**.

#### ③ DIGITAL INPUT:

A selected digital input source is displayed. When **RF, OPTICAL**, or **COAX** is selected, the name is displayed in void characters.

#### ④ MODE:

Displays the current surround mode such as **DOLBY DIGITAL (AC-3), DOLBY PRO LOGIC, MOVIE** surround, **3-STEREO, HALL, MATRIX** surround and **STEREO**.

#### ⑤ MULTI ROOM

Displays the current source selected for the Multi Room output. Such as **TUNER, CD, TAPE, DSS/TV, LD, DVD, VCR** or **AUX**.

#### ⑥ MASTER VOLUME

Displays the current volume level.

The volume level is higher at the right of the display, and the display changes to " □ " at 0 dB.

#### Note:

The On-Screen Display characters are available at the **TV MONI** composite video (RCA) output and at the **TV MONI, S-Video** output jacks. With some video equipment or software, the On-Screen Display characters may be distorted due to noise or tracking adjustment error.

**2. On-screen menu system**

The SR780 incorporates an on-screen menu system, which makes various operations possible by using the cursor and OK buttons on the remote handset.

The settings made with these buttons are also shown in the on-screen display.

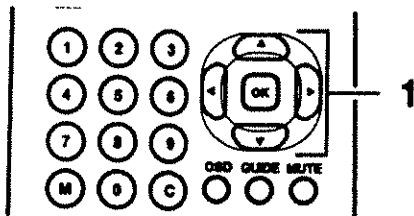

**Note:**  
While "OSD MENU" is selected, the back screen color will change depending on the selected menu. However, the back screen is always displayed in black if the S-VIDEO jack is used.

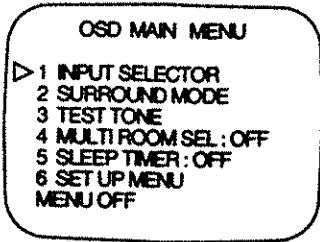

1. Press any one of the cursor buttons (▲, ▼, ►, ◀ and OK buttons) to display "MAIN MENU" of the on-screen display menu. Arrow-shaped cursor "►" can be moved up and down with cursor buttons ▲ and ▼. When selecting the input source, press the OK button with the display as shown on the left.

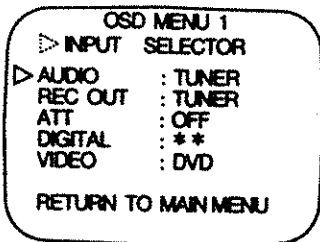

**2. INPUT SELECTOR (OSD MENU 1)**

- AUDIO:** Select the audio source with the ◀ or ► button.  
**REC OUT:** If "DIGITAL" is not selected, the same source is selected in "AUDIO". Can select the audio source with the ◀ or ► button when the digital source is selected.  
**ATT ON/OFF:** Select ATT. ON/OFF with the ◀ or ► button.  
**VIDEO:** Select the video source with the ◀ or ► button.  
**DIGITAL:** Select the digital source with the ◀ or ► button.  
 To determine each source, display the desired source and press the OK button or the ▲ or ▼ button.  
 After the above, press the ▼ or ▲ button to move "►" to "RETURN TO MAIN MENU" and press the OK button to return to "MAIN MENU".

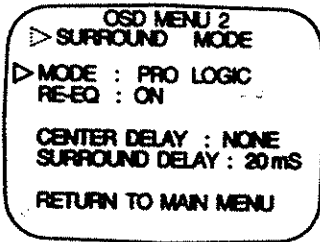

**3. SURROUND MODE (OSD MENU 2)**

- MODE:** Select the surround mode with the ◀ or ► button.  
**DELAY TIME:** Select the delay time with the ◀ or ► button.  
**(CENTER, SURROUND)**

**Note:**  
The DELAY CONTROL of the CENTER CH. is available only when the Dolby Digital (AC-3) mode is selected. The SURROUND CH DELAY has a time difference of 15ms between Dolby Digital (AC-3) and PRO LOGIC modes.

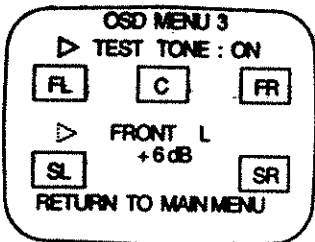
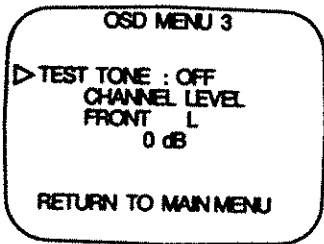

**4. TEST TONE (OSD MENU 3)**

When "TEST TONE" is selected on "OSD MAIN MENU" and press the OK button, the test tone starts from the front L-CH speaker. Press the OK button to select the test tone channels. Adjust the level of test tone from each channel with the CH.LEVEL or ◀/► buttons of the RC2000MKII. The current volume level is shown at the center of the display.

**Note:**  
The test tone can be generated only when the surround mode is Dolby digital (AC-3), PRO LOGIC, MOVIE or 3-STEREO. The test tone is not output to the subwoofer irrespective of ON or OFF selection.

OSD MENU 4  
MULTI ROOM SELECTOR  
▷ MULTIROOM : ON  
SELECTOR : AUX  
VOL LEVEL : -20dB  
RETURN TO MAIN MENU

OSD MENU 5  
SLEEP TIMER SETTING  
▷ TIMER : OFF ON  
TIMER SET : 10Min  
RETURN TO MAIN MENU

OSD MENU 6  
SETUP MENU 1/4  
SPEAKER SETTING  
▷ FRONT CH. : LARGE  
SURROUND CH. : SMALL  
CENTER CH. : LARGE  
SUBWOOFER : ON  
RETURN TO MAIN MENU

OSD MENU 6  
SETUP MENU 2/4  
▷ LFE LEVEL CONTROL  
OFF : 0dB -10 dB  
NIGHT MODE : OFF ON  
RETURN TO MAIN MENU

OSD MENU 6  
SETUP MENU 3/4  
▷ MULTI ROOM VOLUME  
VARIABLE FIXED  
SET LEVEL : -30dB  
RETURN TO MAIN MENU

OSD MENU 6  
SETUP MENU 4/4  
▷ TV AUTO ON/OFF  
ENABLE DISABLE  
SETUP : LOCK UNLOCK  
RETURN TO MAIN MENU

#### 5. MULTI ROOM SELECTOR (OSD MENU 4)

**MULTI ROOM:** To switch on the Multi-room output, move "▶" to "ON"  
**SELECTOR:** Select the source of the Multi-room output with the ◀ or ▶ button.  
**VOL LEVEL:** Adjust the Multi-room output level with the ◀ or ▶ button.

**Note:**

If "MULTI ROOM VOLUME" is set to "FIXED", the Multi-room output level cannot be adjusted with this menu. (In this case, the level should be set with "SET UP MENU 3/4".)

MULTIROOM SELECTOR cannot be selected for the output of RF, OPTICAL and COAX.

#### 6. SLEEP TIMER SET (OSD MENU 5)

**TIMER:** Switch the sleep timer ON and OFF with the ◀ or ▶ button.  
**TIMER SET:** Set the sleep timer period with the ◀ or ▶ button.

#### 7. SETUP MENU 1/4 (OSD MENU 6)

**FRONT CH.:** Select the type of front speaker with the ◀ or ▶ button.  
**SURROUND CH.:** Select the type of surround speaker with the ◀ or ▶ button.  
**CENTER CH.:** Select the type of center speaker with the ◀ or ▶ button.  
**SUBWOOFER:** Switch the subwoofer speaker ON or OFF with the ◀ or ▶ button.

#### 8. SETUP MENU 2/4 (OSD MENU 6)

**LFE LEVEL CONTROL:** Select the output level of the LFE DATA signal included in the Dolby Digital (AC-3) signal. The level is ordinarily set to 0dB. At this time, the LFE indicator is turned on at the display.  
**NIGHT MODE:** Switch the NIGHT mode ON or OFF with the ◀ or ▶ button.

**Note:**

If LFE level is set to 0dB or -10dB, a low voice component is output from the SUBWOOFER output. However, when the SURROUND MODES is in AC-3 MODE and an LFE DATA signal exists in the software for playback, the control is valid. When the SUBWOOFER OUTPUT is OFF, a low voice component is output from the FRONT CH.

#### 9. SETUP MENU 3/4 (OSD MENU 6)

**MULTI ROOM VOLUME:** Select whether the Multi-room output level is to be made variable or fixed with the ◀ or ▶ button.  
**SET LEVEL:** When "MULTI RM VOL." is set to "FIXED", set the level with the ◀ or ▶ button.

#### 10. SETUP MENU 4/4 (OSD MENU 6)

**TV AUTO ON/OFF:** Switch the TV AUTO ON/OFF function to enable (ON) or disable (OFF) with the ◀ or ▶ button.  
**SETUP LOCK:** Selects "LOCK" with the ◀ or ▶ button in order to lock the contents of the SET UP MENU. Then, when the contents of the SETUP MENU is changed, select "UNLOCK" on the "SETUP MENU 4/4".

### 3. Other On Screen Information

When a button is pressed while the on-screen function is activated by the Main unit or remote, the information associated with the button is displayed on the TV screen.

Disappears automatically in about 5 seconds after the button is pressed.

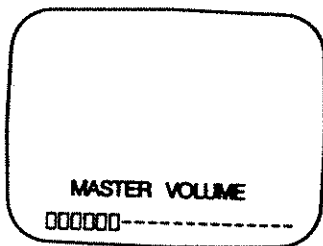
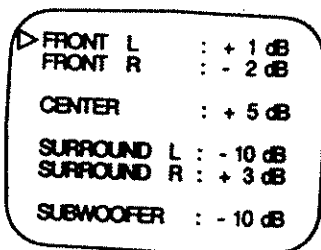
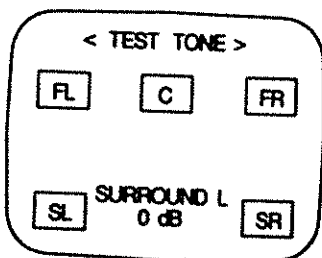
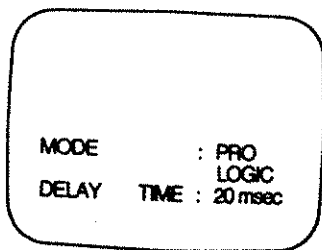
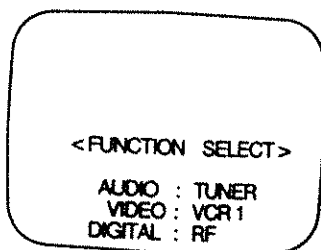

#### 1. When a function selector button is pressed

**AUDIO:** Displays the current audio source.

**VIDEO:** Displays the current video source. When **DSS/TV, LD, DVD, VCR** or **AUX** is selected with the function selector, both **AUDIO** and **VIDEO** shows the same name.

**DIGITAL:** Displays the current digital source.

**Note:**

The name of the source to played back from the Speaker is displayed in void characters.

#### 2. When a button related to SURROUND mode is pressed

**MODE:** Displays the current Surround mode.

**DELAY TIME:** Displays the current delay time.  
 DELAY TIME is not displayed when the surround mode is set to 3-STEREO or STEREO.

#### 3. When the TEST button is pressed:

This display appears only when the mode is, **Dolby Digital (AC-3), PRO LOGIC, 3-STEREO** or **MOVIE SURROUND**.

The speakers generating the test tone change every time the channel select (**CH.SEL**) button of the remote handset is pressed. The current speakers which generate the test tone are indicated by blinking boxes.

The center or surround speaker is not displayed while the **SPEAKER SETTING** on **SETUP MENU 1/4** is **OFF**.

#### 4. When the CH.SEL or a CH.LEVEL button is pressed:

Every time the **CH.SEL** button is pressed, the cursor of the channel is moved in order of **FRONT L** → **FRONT R** → **CENTER**..... When one of the **CH.LEVEL** buttons is pressed while a channel name is displayed with cursor, the level display varies.

Only the usable channels which are determined depending on the **SURROUND** mode, **SPEAKER SETTING** is displayed.

#### 5. Displayed when the MASTER volume is varied or a button of the remote handset is pressed:

The box display changes to "□" at 0 dB.

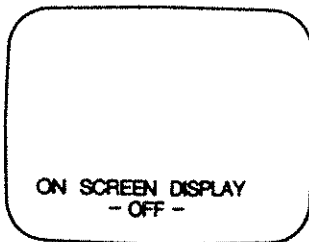
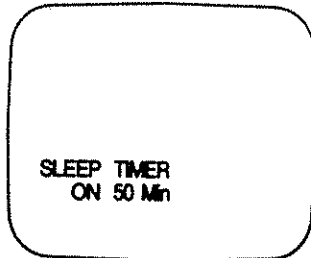
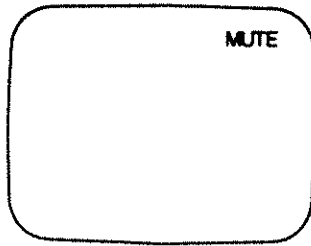

6. **When the MUTE button is pressed:**  
The display disappears when muting is canceled.

7. **When the SLEEP button is pressed:**  
The setting and the remaining time of the sleep timer function are displayed.

8. **When the OSD button is pressed again:**  
In 5 seconds, the characters and blue background disappear automatically.

**Note:**

The On-Screen Display characters are available at the TV MONI composite video (RCA) output and at the TV MONI, S-Video output jacks, except any of the VCR video output jacks.  
-With some video equipment or software, the On-Screen Display characters may be distorted due to noise or tracking adjustment error.

## BASIC OPERATION

### LISTENING TO THE TUNER

1. Press the **POWER** switch ① to turn on the power.
2. Press the **AM/FM** button ⑦ to select the desired band.
3. Press the **TUNING ▲ UP** and **▼ DOWN** buttons ⑬ to tune in the desired station. Pressing once for less than a half second changes the frequency by one step. Pressing longer sequentially scans frequencies in the indicated direction. Releasing the button in this state activates the auto tuning function which automatically scans the frequencies until it reaches a station, at which point the TUNED and signal level indicators light and auto tuning stops.
4. If FM is selected, press the **FM MODE** button ⑫ to select the desired audio mode, stereo or mono.
5. Adjust the volume with the **VOLUME** control ⑩.  
If necessary, adjust the tone controls (**BASS/TREBLE**) ⑧.

### MODE button operation (Tuner Control)

When "AUTO" is on in the display, FM stations which broadcast in stereo will be received in stereo and the "STEREO" indicator lights. When "AUTO" is off, all the FM stations will be received in monaural regardless of whether or not they are broadcasting in stereo.

### PRESETTING STATION

With this unit you can preset up to 30 FM/AM stations in any order. For each station, you can memorize the frequency and reception mode if desired. Stations can be preset either manually (by you) or automatically (by the tuner).

#### AUTO PRESETTING

This function scans the frequencies in the selected band and automatically presets all stations which can be received.

1. Select the **FM** band.
2. Tune in the lowest receivable frequency.
3. While pressing the **MEMO** button ⑨, press the **TUNING ▲ UP** button ⑬. Auto memory starts at this point.
4. "MEMO" will blink on the display.
5. When a receivable station is picked up, scanning stops and station is played for five seconds. During this period, the following operations are possible:
  - 1) The band can be changed using the **FM** or **AM** buttons ⑦.
  - 2) The mode can be changed using the **MODE** button ②.
6. If no button is pressed during this period, the current frequency is preset in location CH-1.  
If you wish to skip current station, press the **TUNING ▲ UP** button ⑬ during this period, the current frequency is skipped and auto presetting continues.
7. Operation stops automatically when all 30 preset memory positions are filled or when auto scanning attains the highest end of all bands. To stop the auto preset function in mid-operation, press the **CLEAR** button ⑭ or one of the input selectors.

#### MANUAL PRESETTING

As the SR780 is not equipped with the numeric buttons on the main unit, use the remote control unit for manual preset operation. Refer to "Ten keypad" on page 12.

1. Refer to the "Basic operation" section above to tune in a desired station.
2. Press the **MEMO** button ⑨.  
"MEMO" starts blinking in the display. While "MEMO" is still blinking (approx. 5 seconds), enter a number from 1 to 30 using the number keys.
3. When a number has been properly input, "MEMO" stops blinking and goes out. The station is now stored in the specified preset memory location.
  - \* When entering a single digit number (2, for example), either input "02" or just input "2" and wait for a few seconds.
  - \* If a number other than 1-30 is entered by mistake, that number flashes in the display to indicate that it is invalid and the display returns to the original frequency display.

### RECALLING A PRESET STATION

1. Direct selection method using the number buttons.  
Select the desired preset station by entering one or two digits using the number buttons.  
(Use the remote handset.)
2. Sequential selection method using the **PRESET ▲UP / ▼DOWN** buttons ⑰.  
Each press of the **▲UP** or **▼DOWN** button moves to the next or previous preset station. You can "fast forward" or "fast reverse" through the preset stations by holding down the **▲UP** or **▼DOWN** buttons. The operation continues until the button is released.
  - \* If the **PRESET ▲UP** or **▼DOWN** button is pressed while the channel number is not displayed, the preset channel with the smallest preset number will be recalled.

### PRESET SCAN TUNING

1. Press the **P.SCAN** (preset scan) button ⑱.  
"P-SCAN" blinks on the display. (The preset station with the smallest preset number is recalled first. If no stations have been preset, CH"00" blinks in the display and the unit returns to the previous mode.)
2. Preset stations are recalled in sequence (CH-1 → CH-2, etc.) for 5 seconds each. Preset numbers that do not contain stations are skipped.
3. You can fast forward the preset stations by pressing the **PRESET ▲UP** button ⑰ continuously.  
When the desired preset station is received, cancel the preset scan operation by pressing the **PRESET ▼DOWN** or **P.SCAN** button.

### CLEARING PRESET STATIONS

You can remove preset stations from memory using the following procedure.

1. Recall the preset number to be cleared with the method described in "Recalling a preset station".
2. Press the **MEMO** button ⑨. "MEMO" blinks in the display for 5 seconds. While "MEMO" is still blinking, press the **CLEAR** button ⑭. "CLEAR" appears on the display to indicate that the specified preset number has been cleared.
  - \* If desired, you can clear all of the memory contents with a single operation, as follows:  
Press the **MEMO** button ⑨, **CLEAR** button ⑭ and **TUNING ▲UP** button ⑬ simultaneously.

#### CAUTION:

Remember that the memory clear operation clears all memory including the volume level and surround mode memory and turns the power OFF.

● **Station name preset**

The station name preset function allows the name of each preset channel to be entered using alphanumeric characters. The Station Name button is valid only in the tuner mode. Before station name preset operation, store stations with the preset memory operation described on the previous page.

1. Press the **MEMO** (19) button for more than 3 seconds.
2. The leftmost column of the station name indicator flashed, indicating the character entry ready status.

**[Operation using the buttons on the main unit]**

3. When the **TUNING ▲ UP** button (14) is pressed, alphabetic and numeric characters will be displayed in the following order:  
**A → B → C ... Z → 1 → 2 → 3 ... 0 → → (Blank) → A**  
**UP →**  
**← DOWN**

Holding the button depressed displays alphanumeric characters at high speed, and pressing the **▼ DOWN** button reverses the order.

4. After selecting the first character to be entered, press the **MEMO** button (19). The entry in this column is fixed and the next column starts to flash. Fill the next column and press the **MEMO** button (19) for more than 1 second to confirm the entry.

**Note:**

Unused columns should be filled by entering blanks.

**[Operation using the buttons on the remote control]**

First, press the **TUNER** button on the remote handset. (This operation is not necessary if the remote handset has already been operated in the **TUNER** mode.)

3. Enter the character using the numeric buttons (5).  
 For the example, to enter "A":  
 1) Press the "1" button. "A" appears on the display column.  
 2) Every time the "1" button is pressed, the displayed character changes in the order: A → B → C → 1 → A...  
 Pressing buttons other than the "1" button cause different characters to be displayed in a similar way, so that other alphanumeric characters can be entered.  
 To enter a blank or space, press the "9" button.
4. When the desired character is displayed, press the **MEMO** button (19) to confirm the entry in this column and move to the next column. After having filled all of the 8 columns, press the **MEMO** button (19) for more than 1 second again.

**PLAYBACK OPERATION**

**NORMAL PLAYBACK**

1. Press the **POWER** switch (1) to turn on the power.
2. Press the desired input selector (7) according to the table shown below.
3. Start playing the desired source.
4. Adjust the volume using the **VOLUME** control (11). If necessary, adjust the tone using the **BASS** and **TREBLE** controls (8).

Source component	Input selector
FM or AM	FM/AM
CD player	CD
Cassette deck	TAPE
DVD player	DVD
Digital Satellite tuner or TV tuner	DSS/TV
LD player	LD
Video Recorder	VCR
Camcorder	AUX

**Note:**

Press one of the function buttons twice within 2 seconds to select the function with RC2000MKII.

**LISTENING TO A DIFFERENT AUDIO SOURCE WHILE WATCHING A VIDEO SOURCE**

1. Select one of the following video sources (7) **DSS/TV, LD, DVD, VCR, or AUX.**
2. Next, select one of the following audio sources (7) **FM, AM, or CD, TAPE** or the following digital audio sources (8) **RF, OPT, or COAX.** Adjust the volume using the **VOLUME** control (11).

**VIDEO SOURCE RECORDING OR COPYING**

In this example, the video and audio from a laserdisc player are recorded onto a video tape in a VCR.

1. Press the **LD** function button (7).
2. Start playing the LD player.
3. Start recording on the VCR.

For details on playback and recording operation, refer to the instruction manuals provided with the video components.

**SETTING THE SLEEP TIMER (only remote control unit)**

■ **Set the sleep timer while the power is turned on.**

1. Turn the power QN and press the **SLEEP** button D7 on page 4 at AMP mode.  
 "SLEEP" blinks in the display.
2. Within 5 seconds, press the **MEMO** button (13) (19).  
 "SLEEP 10" is displayed.
3. Press the **SLEEP** button D7 a number of times to set the desired sleep time.  
 Each press of the **SLEEP** button D7 changes the display in the following order:

10 → 20 → 30 → 40 → 50 → 60 → 90 → OFF

4. Press the **MEMO** button (13) (19) to complete the setting.  
 "SLEEP" stops blinking and lights steadily.  
 • While the sleep timer is activated, the remaining time can be displayed for about 2 seconds by pressing the **SLEEP** button D7.  
 • To cancel the sleep timer, press the **SLEEP** button D7 and then press the **CLEAR** button (14) (14).

**TV AUTO ON/OFF FUNCTION**

This function allows the component connected to the DSS/TV IN jack to control the power (ON/OFF) to the SR780.

**Auto Power On**

1. Connect your TV TUNER (etc) to the DSS/TV IN terminal.  
 Be sure to connect the video input.
2. Turn OFF the power to the TV TUNER and the SR780.
3. Turn ON the TV TUNER and tune a receivable station.
4. When the station is received, the SR780 turns ON and DSS/TV is selected automatically.

**Auto Power OFF**

1. In the above situation, turns the TV TUNER OFF or select a channel that does not contain any broadcast.
2. The power to the SR780 switches to STANDBY after about 5 minutes.

**Note:**

AUTO POWER OFF is canceled if the INPUT SLECTOR is set to a source other than DSS/TV. The function reactivates when DSS/TV selected again.

**Caution:**

Some TV broadcasts may cause the TV AUTO FUNCTION turned ON. To set this function ON/OFF, refer SETUP MENU/4/4 on OSD MENU 6.



## DIGITAL INPUT SOURCE PLAYBACK

### AC-3 RF INPUT

1. Connect the RF Output jack of the LD PLAYER with the AC-3 RF input jack of the SR780. For the connection cable, use the cable dedicated for RF or VIDEO cable attached to the LD PLAYER.
2. Set the DISC to be played back at the LD PLAYER.
3. Press the **RF** button of the FUNCTION SELECTOR buttons (DIGITAL INPUT).
4. Play back the LD PLAYER.
5. Using the VOLUME control, adjust the volume.

### AC-3/PCM OPTICAL/COAXIAL INPUT

1. Connect the digital output jack of the DVD or CD PLAYER with the AC-3/PCM OPTICAL or COAXIAL input jack of the SR780. For the COAXIAL input, use the VIDEO cable. For the OPTICAL input, use the dedicated optical cable.
2. Set the DISC to be played back at the PLAYER.
3. Press the **OPTICAL** or **COAXIAL** of the FUNCTION SELECTOR button (DIGITAL INPUT).
4. Play back the PLAYER.
5. Using the VOLUME control, adjust the volume.

**Note:**

Examine the encoded format of a disc to be played back. When the AC-3 mode has been selected in the Surround modes and the PCM signal other than the Dolby Digital (AC-3) signal is entered, the AC-3 mode is not available for playback. In such a case, the disc is automatically played back in the STEREO mode. For example, if the PRO LOGIC mode is set before the AC-3 mode has been set, the input signal is played back in the STEREO mode. Also, when a disc formatted with the Dolby Digital (AC-3) signal, the surround mode is Automatically set to the AC-3 mode. The format of a disk to be played back appears at the display with the Dolby Digital (AC-3) or other PCM code indicator. When the Surround mode is set to the Dolby Digital (AC-3) and if a signal other than the Dolby Digital (AC-3) signal or other PCM signals, "NO DATA" appears. When the display appears, examine the encoded format of the disc for connection or playback of the PLAYER now under playback.

### AC-3 CHANNEL STATUS INDICATOR

AC-3 channel status is displayed when a software formatted with Dolby Digital (AC-3) is decoded. An ordinary Dolby Digital (AC-3) signal is indicated as "3/2.1". An ordinary Dolby Digital (AC-3) signal is organized 3 front channels (left, center and right channel), 2 surround channels (left and right channel) and 0.1 LFE signal. 2 channel stereo signal is indicated as "2/0".

This indicator is displayed while Dolby Digital (AC-3) is decoded.

**Note:**

The channel status of following software is indicated as "3/1", and "PRO LOGIC" is indicated as surround mode. The software is encoded as PRO LOGIC, though Dolby Digital (AC-3) signal is inputted.

### ANALOG AUDIO INPUT and DIGITAL INPUT

Selecting an analog audio source such as CD or TUNER outputs a selected analog audio signal at the TAPE OUT or VCR OUT. This output has no relationship with the selection of the FUNCTION SELECTOR button (DIGITAL INPUT). For example, selecting RF for the digital SOURCE and selecting DVD for the analog audio source, RF/DVD appear at the display, and at the SPEAKER OUT, the source connected to RF is played back. However, the analog audio signal of the DVD is output to the TAPE or VCR OUT jack. In other words, even when RF has been selected for the digital source, the analog source is selected and an analog audio signal is output at the TAPE or VCR OUT jack. Also, for the VIDEO signal, the DVD signal is output at the TV/MONI output jack. When a source without a VIDEO signal such as CD, the video signal of a source indicated in the VISUAL SOURCE INDICATOR of the display is output.

**Note:**

The digital source signal is not output to TAPE OUT or VCR OUT.

## INDICATION OF FUNCTION SELECTOR

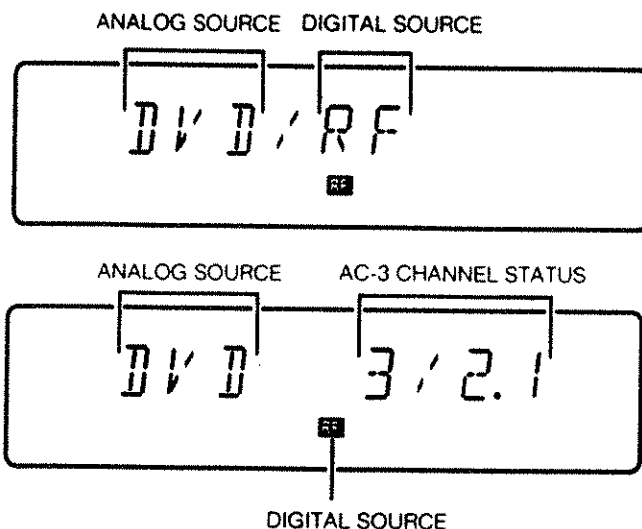

**Note:**

Automatic detection of Dolby Digital (AC-3)/PCM is not available with some input signal. In such case, select correct surround mode depending on input signal by pressing the **SURROUND MODE** key.

# SURROUND MODES

The SR780 incorporates digital signal processors (DSP) which can reproduce various surround effects you experience in concert halls and movie theaters, etc. Six Surround Modes, are provided to reproduce a variety of surround sound effects, according to the content of the source to be played

	FEATURES	DELAY TIME CONTROL RANGE
<b>1. DOLBY DIGITAL (DOLBY AC-3)</b>	In this mode, the source encoded with the Dolby Digital (AC-3) signal is decoded. Use this mode for the software source encoded into the Dolby Digital (AC-3) signal such as for LD or DVD PLAYER.	Center 0 - 5 mS Surround 0 - 15 mS
<b>2. DOLBY PRO LOGIC</b>	This mode features Dolby Pro Logic surround sound decoding, with no additional processing. Use this mode with Dolby Surround encoded software sources, such as video tape and video disc, stereo TV and cable broadcasts, and even stereo audio sources such as CD. Even if the stereo TV or audio source is not surround encoded, often the Dolby Pro Logic processing can provide a pleasing surround sound effect.	15 - 30 mS Initial setting: 20 mS
<b>3. MOVIE SURROUND</b>	Movie Surround processing features surround decoding with the option to extend the delay time to 90 milli-seconds. This mode can be used in very large rooms, or to experiment with delay times greater than 30 milli-seconds. Please review the section below concerning how to properly set the delay time for your particular home theater setup.	40 - 90 mS Initial setting: 40 mS
<b>4. 3-STEREO</b>	If the left and right speakers are located far apart, the sound field of the center channel is degraded. This mode is used to improve the sound field center by applying directivity enhancement provided by the Dolby Pro Logic Surround decoder.	No delay applicable
<b>5. HALL SURROUND</b>	The sound in actual concert halls is a complex combination of direct and reflected sounds. This mode provide a sound-field effect of medium-sized circular hall with rich reverberations.	40 - 90 mS Initial setting: 40 mS
<b>6. MATRIX SURROUND</b>	This mode is effective for playing sports broadcasts or outdoor live concerts. It provides a surround mode with a wide surround effect.	40 - 90 mS Initial setting: 40 mS
<b>7. STEREO</b>	The surround mode is off in this position, and the sound is reproduced in normal stereo.	

### Delay time:

For the various surround sound modes, the surround sound information is delayed slightly, in order to compensate for the physical layout of your home theater speakers. This delay ensures that the main sounds from the front speakers and the surround sounds from the surround speakers arrive at the listening position properly synchronized. If the delay is not set correctly, the surround sound effect is not nearly so pleasing, and in fact can be distracting and annoying. The correct method to calculate the surround sound delay is as follows:

1. Measure the distance from the listening/viewing position to the plane of the front speakers and note the result. For example, we will use a 10 foot measurement from the listener's chair to the front speakers.
2. Measure the distance from the listening position to the location of the surround speakers. Ideally, the surround speakers will be mounted high up on the side walls immediately to the left and right of the listening position. For our example, we will use a 5 foot measurement from the listening position to the surround speakers.
3. Subtract the surround distance from the front distance, and add the number 15. The result is the correct setting for proper delay time, in milli-seconds. For our example: 10 feet minus 5 feet=5. Add 15, total=20. 20 msec of delay will achieve the proper surround decoding result.

It is widely misunderstood that lots of delay time is somehow preferable to a small amount of delay time. This is not the case. The amount of surround delay time is calculated so that the arrival time of the surround sound to the ears is "sync" with the arrival time of the front sounds to the ears. By overly increasing the delay time of the surround channel, this optimum sound arrival synchronization is altered, and the surround sound becomes "detached" from the main sound, destroying the spatial aspects of the surround sound. The Dolby delay time adjustment of 15 to 30 msec allows for a wide variety of home theater set-ups, room sizes, and listening positions.

DOLBY DIGITAL (AC-3) SURROUND DELAY

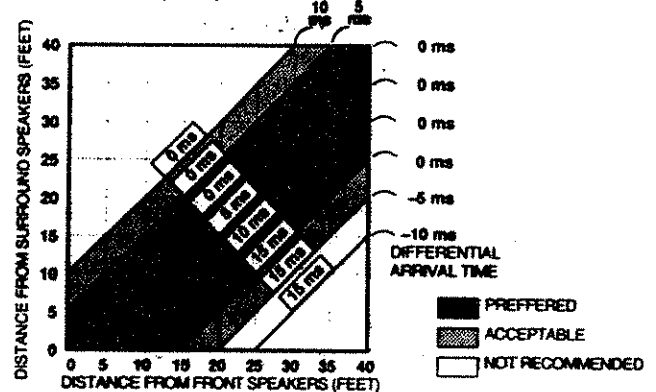

PRO LOGIC SURROUND DELAY

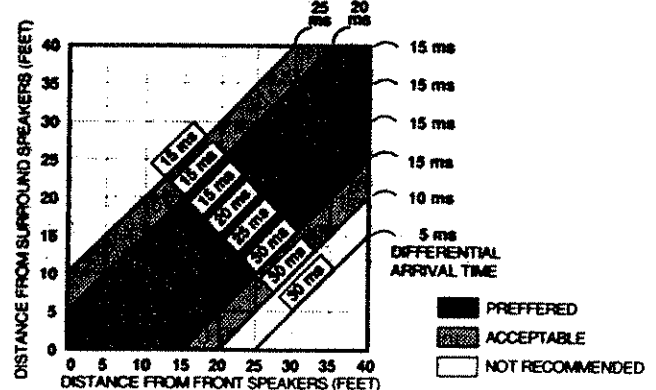

# PLAYBACK OF DOLBY DIGITAL (AC-3) OR OTHER SURROUND MODE AT DIGITAL INPUT SOURCE

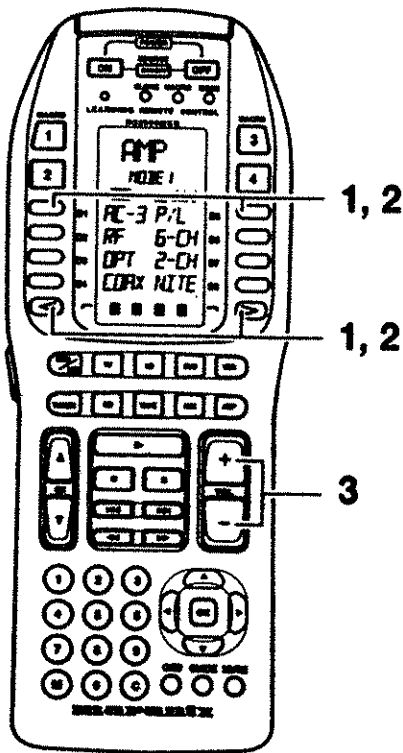
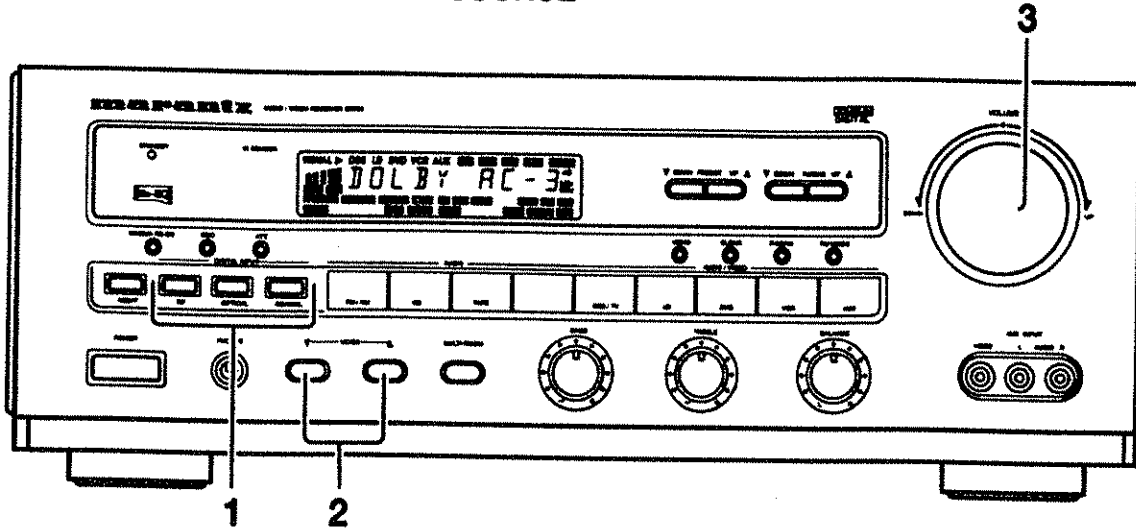

1. Press RF/OPT/COAX of FUNCTION SELECTOR (DIGITAL INPUT) button to select the input source. In remote control, set it the page 4 with the PAGE button at AMP mode. Then, press the DIRECT button of the corresponding source.
2. Press the MODE (SURROUND Mode) button to select the desired surround mode. On the remote, set the page 1 with PAGE button and select the desired surround mode.  
\*Play a source (When the AC-3 digital mode is entered, the SURROUND Mode is changed over to the AC-3 mode.)
3. Adjust the overall sound to your preferred listening level by using the main VOLUME control on the front panel (of MASTER VOLUME up/down on the remote.)

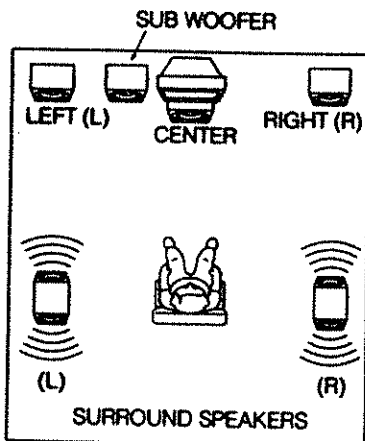

**PLAYBACK OF DOLBY PRO LOGIC, MOVIE AND 3-STEREO SURROUND MODES**

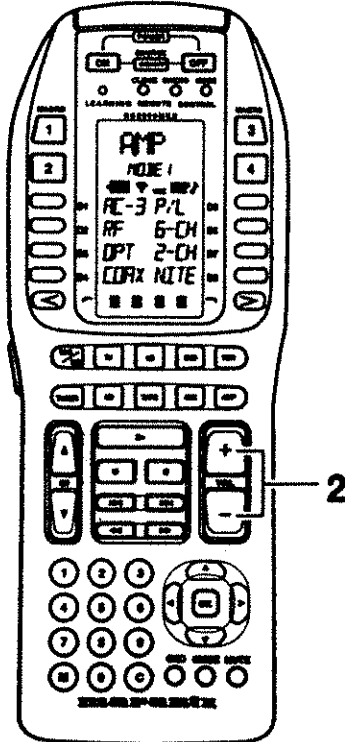
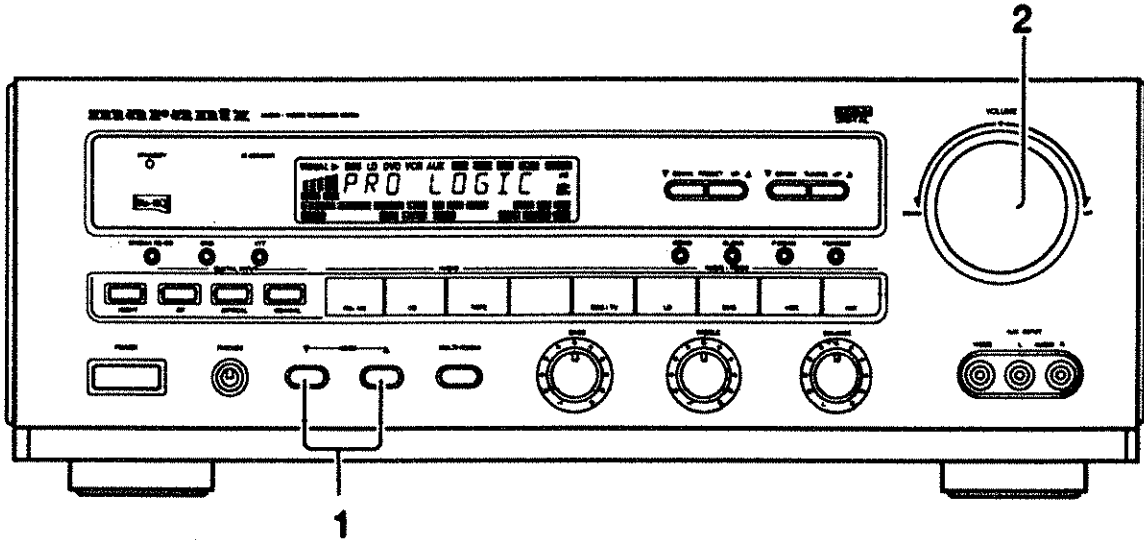

1. Press the **MODE** (SURROUND Mode) button to select the PRO LOGIC mode.
- **Play a source**
2. Adjust the overall sound to your preferred listening level by using the main **VOLUME** control on the front panel (of **MASTER VOLUME** up/down on the remote).

**Note:**  
In the **MOVIE SURROUND** mode, the delay time can be adjusted from 40 ms to 90 ms in 10 ms steps.

**With the SR780, the input balance is adjusted automatically.**

- The input balance is adjusted automatically, so it is not necessary to adjust it every time the source is changed. It is designed to minimize crosstalk, so the maximum effects of the PRO LOGIC, 3-STEREO and MOVIE SURROUND can be obtained.

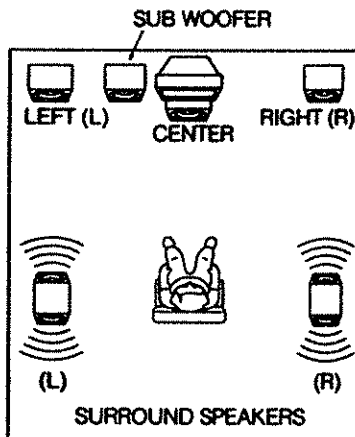

# PLAYBACK OF HALL AND MATRIX MODES

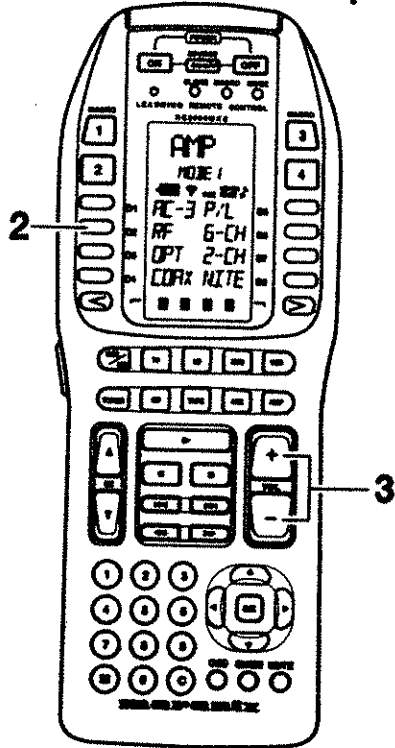
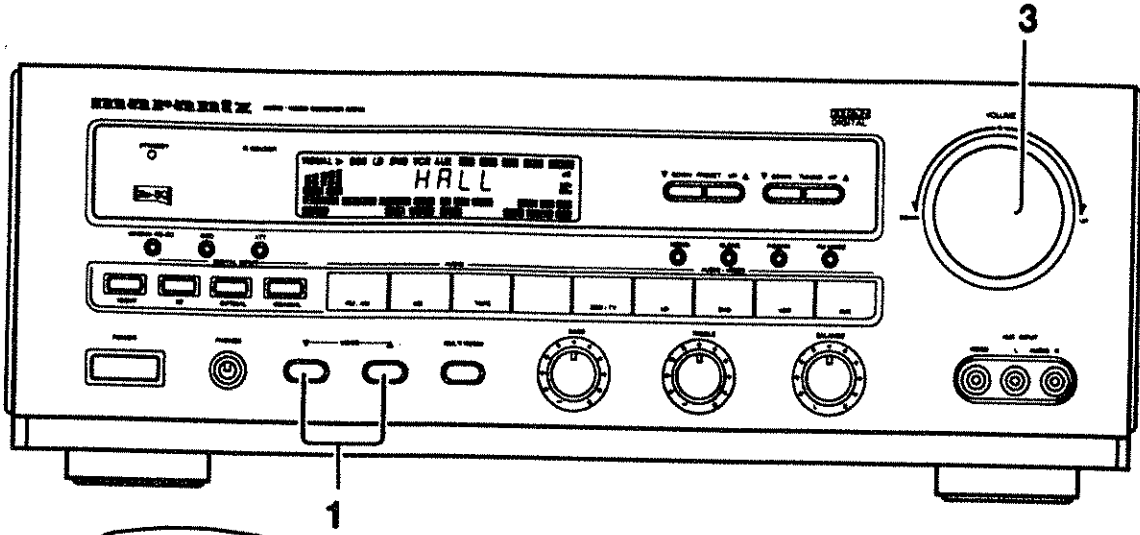

1. Press the **MODE** (SURROUND Mode) button to select the HALL or MATRIX mode.

• **Play a source**

2. Adjust the delay time with D2 button on page 2 at AMP mode. The delay time is variable in the following sequence.

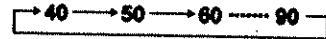

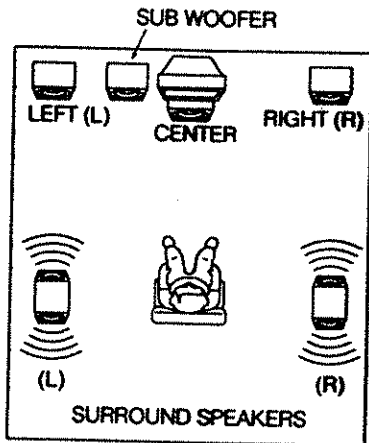

3. Adjust the overall sound to your preferred listening level by using the main **VOLUME** control on the front panel (of **MASTER VOLUME** up/down on the remote).



## Multi Room Selector

The Multi Room Selector is a function which allows you to listen to the same or a different source in a room other than the room in which the AV550 is located. To use this function, multi room remote control unit and remote control signal receiver available from your Marantz dealer are necessary. The operations possible with the multi room function are explained briefly below. For details, refer to the instruction manual supplied with the multi room remote control unit and receiver.

1. Press the **MULTI ROOM** button . The unit enters multi room mode and "MULTI" lights on the display.  
(Multi room mode can be selected even when the SR780 **POWER** switch  is set OFF (STANDBY) from the multi room with remote control.)

Immediately after pressing the **MULTI ROOM** button  ON, the source can be selected and the output level can be set by following the displayed menus.

- 1) Press the **MULTI ROOM** button , the display indicates "SEL SOURCE" and flashing the MULTI indicator for about 10 seconds. In this time, you can select the function by pressing the function button (FM/AM, CD, LD, etc)
- 2) After above, the display indicates "MULTI VOL" "VOLUME xx dB" for about 5 seconds. In this time, you can set the volume level of the multi room.

### Caution:

If the main room is active (not standby mode), you cannot select the band except the band of the main room. For example, if the FM band is selected in the main room, you cannot select the AM band in the multi room.

The operating procedure for this is the same as the Multi-room operations using the remote handset.

2. In multi room mode, the multi room remote control unit can be used in the multi room to operate the following functions.  
You can select a tuner preset channel and tuning up or down, or PLAY PAUSE, FF, REW or STOP a CD player or tape deck connected to the SR780. When operating the tuner, use the **PRESET ▲UP** and **▼DOWN** buttons  to select from CH1 to CH30.

### Note:

If the tuner is selected, one or more radio stations must be memorized in the preset channels.

## Multi Room Selector Operation

1. Press the SR780's **MULTI ROOM** button  or press the multi room remote control unit's **MULTI ROOM** button, or select the desired source with the selector from the MULTI ROOM. Any of these operations will put the SR780 into multi room mode and "MULTI" will light in the display.
2. Press the multi room remote control unit's **VOL.UP** button to set the desired sound volume.

### Note:

If the Multi-room volume has been set to "FIXED" with "MULTI ROOM VOLUME." in "SETUP MENU 4/4", it is not possible to adjust the volume level from the other room.

## To listen to a CD in the multi room

This procedure lets you operate a compatible Marantz CD player connected to the SR780 from the multi room.

1. Select CD on the multi room remote control unit.
  2. Press CD PLAY on the multi room remote control unit.
  3. Press the VOL.UP button on the multi room remote control unit to set an appropriate volume level.
- A compatible cassette deck can be operated in the same manner

### Note:

When using the multi room function, make sure the SR780's **MULTI ROOM** remote control jack and the multi room remote control receiver are connected by co-axial cable terminated with RCA plugs.

- Always be sure to turn the power off after using the multi room function.

When the MULTI-ROOM FUNCTION is operative, POWER to the SR780 in the MAIN-ROOM is turned ON. When the MULTI-ROOM function is not being used (or is finished being used) turn MULTI-ROOM OFF. POWER to the SR780 is also turned OFF.

# TROUBLESHOOTING

In case of trouble, check the following before calling for service:

1. Are the connections made properly ?
2. Are you operating the unit properly following user's guide ?
3. Are the power amplifiers and speaker working properly ?

If the unit does not operate properly, check items shown in the following table.

If your trouble cannot be recovered with the remedy actions listed in the following table, malfunction of the internal circuitry is suspected; immediately unplug the power cable and contact your dealer, nearest Marantz distributor or the Marantz Service Center in your country.

	SYMPTOM	CAUSE	SOLUTION
Trouble occurring regardless of sources, i.e. during CD playback, tape playback and FM reception, etc.	The display lights but no sound or picture is produced.	<ul style="list-style-type: none"> <li>• The input/output cord connections are incomplete.</li> <li>• The MUTING switch is ON.</li> <li>• The position of the function selector is not correct.</li> <li>• The VOLUME control is turned down all the way.</li> </ul>	<ul style="list-style-type: none"> <li>• Make sure all connections are made securely.</li> <li>• Press the MUTING button to turn it off.</li> <li>• Press the function selector of the desired source.</li> <li>• Turn the control to an appropriate level.</li> </ul>
	Sound is output only from the left or right channel.	<ul style="list-style-type: none"> <li>• The input/output cord connections are incomplete.</li> <li>• The left/right balance is off-center.</li> </ul>	<ul style="list-style-type: none"> <li>• Make sure all connections are made securely.</li> <li>• Adjust the CH.LEVEL control correctly.</li> </ul>
Trouble occurring during surround playback.	No sound is produced from the surround speakers.	<ul style="list-style-type: none"> <li>• The surround mode is STEREO or 3-STEREO.</li> <li>• The input signal is monaural.</li> </ul>	<ul style="list-style-type: none"> <li>• Select a mode other than STEREO or 3-STEREO.</li> <li>• The surround channel signal is not output from monaural signals.</li> </ul>
	No sound is produced from the center speaker.	<ul style="list-style-type: none"> <li>• The surround mode is other than AC-3, DOLBY PRO LOGIC SURROUND, 3-STEREO or MOVIE SURROUND.</li> <li>• The center mode is "NONE" position.</li> </ul>	<ul style="list-style-type: none"> <li>• Select one of the DOLBY or MOVIE modes.</li> <li>• Select SMALL or LARGE.</li> </ul>
Trouble related to remote control unit	Remote control operation is not normal.	<ul style="list-style-type: none"> <li>• The batteries are exhausted.</li> <li>• The remote control unit is operated too far away from the main unit.</li> </ul>	<ul style="list-style-type: none"> <li>• Replace both batteries with new ones.</li> <li>• Operate the remote control unit at a closer distance to the main unit.</li> </ul>

## GENERAL MALFUNCTION

If the equipment malfunctions, this may be because an electrostatic discharge or AC line interference has corrupted the information in the equipment memory circuits. Therefore:

- disconnect the plug from the AC line supply
- after waiting at least three minutes, reconnect the plug to the AC line supply
- re-attempt to operate the equipment

## HOW TO RESET THE UNIT

Should the operation or display seem to be abnormal, reset the unit with the following procedure.

On the main unit is turned on, press and hold the MEMO, CLEAR and TUNING UP buttons simultaneously.

Remember that the procedure will reset the settings of the function selector, Surround mode, delay time, TUNER PRESET etc., to their initial settings.

### Memory backup

- In case a power outage occurs or the power cord is accidentally unplugged, the SR780 is equipped with a backup function to prevent memory data such as the preset memory from being erased.  
The memory functions are backed up for up to about one week.

# TECHNICAL SPECIFICATIONS (U VERSION)

## FM TUNER SECTION

Frequency Range .....	87.5 - 108.0 MHz
Usable Sensitivity .....	IHF 1.3 eV/13.5 dBf
Signal to Noise Ratio .....	Mono/Stereo 76/68 dB
Distortion .....	Mono/Stereo 0.2/0.5 %
Stereo Separation .....	1 kHz 40 dB
Alternate Channel Selectivity .....	± 400 kHz 65 dB
Image Rejection .....	98 MHz 50 dB
Tuner Output Level .....	1 kHz, ± 75 kHz Dev 800 mV

## AM TUNER SECTION

Frequency Range .....	520 - 1710 kHz
Signal to Noise Ratio .....	50 dB
Usable Sensitivity .....	Loop 500 µV
Distortion .....	1 kHz, 30 % Mod. 0.5 %
Selectivity .....	± 20 kHz 70 dB

## AUDIO SECTION

Rated Power	
FRONT (20 Hz - 20 kHz) .....	8 ohms 80W / Ch
Center (40 Hz - 20 kHz) .....	8 ohms 80W / Ch
Surround (1 kHz) .....	8 ohms 80W / Ch
THD Front (20 Hz - 20 kHz) .....	8 ohms 80W / Ch
Input Sensitivity/Impedance	8 ohms 0.05 %
Linear .....	
Signal to Noise Ratio (IHF A)	220 mV/40 Kohms
Linear .....	
Dolby Surround Adjacent Channel Separation (AC-3) .....	85 dB
	55 dB

## VIDEO

Television Format .....	NTSC
Input Level/Impedance .....	1 Vp-p/75 ohms
Output Level/Impedance .....	1 Vp-p/75 ohms
Video Frequency Response .....	5 Hz to 8 MHz (-1 dB)
S/N .....	63 dB

## GENERAL

Power Requirement .....	AC 120 V 60 Hz
Power Consumption (STEREO MODE RATED POWER) .....	300 W
Dimension (MAX)	
Width .....	17-1/4 inches (439 mm)
Height .....	6-1/4 inches (158 mm)
Depth .....	18 inches (458 mm)
Weight .....	30.9 lbs (14.0 Kg)

## ACCESSORIES

Remote Control Unit RC2000MKII .....	1
AA-size batteries .....	4
FM Feeder Antenna .....	1
FM Antenna Converter (U version only) .....	1
AM Loop Antenna .....	1

Specifications subject to change without prior notice.