

Panasonic

Digital Super Hybrid System Installation Manual

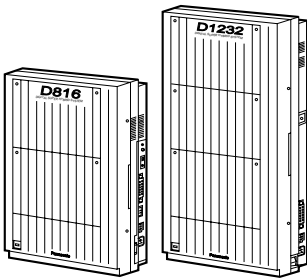

KX-TD816
Model KX-TD1232



Thank you for purchasing this Panasonic Model KX-TD816/KX-TD1232, Digital Super Hybrid System. Please read this manual before connecting the Digital Super Hybrid System. This manual is for software version P341I, P342I or later for KX-TD816 and P241I, P242I or later for KX-TD1232.

System Components

System Components Table

	Model	Description
Service Unit	KX-TD816	Digital Super Hybrid System (Main Unit)
	KX-TD1232	Digital Super Hybrid System (Main Unit)
Telephone	KX-T7520	Digital proprietary telephone
	KX-T7531	Digital proprietary telephone with 1-line display
	KX-T7533	Digital proprietary telephone with 3-line display
	KX-T7536	Digital proprietary telephone with 6-line display
	KX-T7550	Digital proprietary telephone
	KX-T7425	Digital proprietary telephone
	KX-T7433	Digital proprietary telephone with 3-line display
	KX-T7436	Digital proprietary telephone with 6-line display
	KX-T7450	Digital proprietary telephone
	KX-T7220	Digital proprietary telephone
	KX-T7230	Digital proprietary telephone with 2-line display
	KX-T7235	Digital proprietary telephone with 6-line display
	KX-T7250	Digital proprietary telephone
	KX-T7320	Proprietary telephone
	KX-T7330	Proprietary telephone with 1-line display
	KX-T7350	Proprietary telephone
	KX-T7130	Proprietary telephone with 1-line display
	KX-T7020	Proprietary telephone
	KX-T7030	Proprietary telephone with 1-line display
	KX-T7033	Proprietary telephone with 1-line display
	KX-T7050	Proprietary telephone
KX-T7055	Proprietary telephone	
KX-TD7500	DECT portable station	

System Components Table

	Model	Description
Optional Equipment	KX-T7540	Digital DSS Console
	KX-T7541	Digital Attendant Console
	KX-T7545	Add-on Key Module
	KX-T7440	Digital DSS Console
	KX-T7441	DSS Console for Attendant
	KX-T7240	Digital DSS Console
	KX-T7040	DSS Console
	KX-T7340	DSS Console
	KX-TD142	Cell Station
	KX-TD144	Cell Station Interface Unit
	KX-TD146	Cell Station Interface Unit
	KX-TD160	Doorphone Card
	KX-TD170	8-Station Line Unit
	KX-TD174	16 SLT Line Circuit Unit
	KX-TD180	4-CO Line Unit
	KX-TD184	E&M (TIE) Line Unit
	KX-TD189	Pay Tone Card
	KX-TD190* ¹	DISA Unit
	KX-TD191* ²	DISA Card
	KX-TD192* ²	System Inter Connection Card (two cards with Connection Cable)
	KX-TD194	SLT Message Waiting Lamp Adaptor Unit
	KX-TD196* ²	Remote Card
	KX-TD197	High Speed Remote Card
	KX-TD198* ¹	Remote Unit
	KX-TD199* ¹	DISA Card
	KX-TD280	2-ISDN S0 Line Unit
	KX-TD286	6-ISDN S0 Line Unit
	KX-TD290	Primary Rate Interface ISDN Expansion Unit
	KX-T30865	Doorphone
	KX-A46	Battery Adaptor
	KX-A277	AC Adaptor

*¹ Can be installed in the KX-TD816 only.

*² Can be installed in the KX-TD1232 only.

Note

- In this manual, the suffix of each model number are omitted.

Important Information

When using your telephone equipment, basic safety precautions should always be followed to reduce the risk of fire, electric shock and injury to persons, including the following:

- a) Read and understand all instructions.
- b) Follow all warnings and instructions marked on the product.
- c) Unplug this product from the wall outlet before cleaning. Do not use liquid cleaners or aerosol cleaners. Use a damp cloth for cleaning.
- d) Do not use this product near water, for example, near a bathtub, wash bowl, kitchen sink, or laundry tub, in a wet basement, or near a swimming pool.
- e) Do not place this product on an unstable cart, stand, or table. The product may fall, causing serious damage to the product.
- f) Slots and openings in the cabinet and the back or bottom are provided for ventilation, to protect it from overheating, these openings must not be blocked or covered. The openings should never be blocked by placing the product on the bed, sofa, rug, or other similar surface. This product should never be placed near or over a radiator or heat register. This product should not be placed in a built-in installation unless proper ventilation is provided.
- g) This product should be operated only from the type of power source indicated on the marking label. If you are not sure of the type of power supply to your home, consult your dealer or local power company.
- h) This product is equipped with a three wire grounding type plug, a plug having a third (grounding) pin. This plug will only fit into a grounding type power outlet. This is a safety feature. If you are unable to insert the plug into the outlet, contact your electrician to replace your obsolete outlet. Do not defeat the safety purpose of the grounding type plug.
- i) Do not allow anything to rest on the power cord. Do not locate this product where the cord will be abused by people walking on it.
- j) Do not overload wall outlets and extension cords as this can result in the risk of fire or electric shock.
- k) Never push objects of any kind into this product through cabinet slots as they may touch dangerous voltage points or short out parts that could result in a risk of fire or electric shock. Never spill liquid of any kind on the product.
- l) To reduce the risk of electric shock, do not disassemble this product, but take it to a qualified serviceman when some service or repair work is required. Opening or removing covers may expose you to dangerous voltages or other risks. Incorrect reassembly can cause electric shock when the appliance is subsequently used.
- m) Unplug this product from the wall outlet and refer servicing to qualified service personnel under the following conditions:
 - 1) When the power supply cord or plug is damaged or frayed.
 - 2) If liquid has been spilled into the product.
 - 3) If the product has been exposed to rain or water.

-
-
- 4)** If the product does not operate normally by following the operating instructions.
Adjust only those controls, that are covered by the operating instructions because improper adjustment of other controls may result in damage and will often require extensive work by a qualified technician to restore the product to normal operation.
 - 5)** If the product has been dropped or the cabinet has been damaged.
 - 6)** If the product exhibits a distinct change in performance.
 - n)** Avoid using a telephone (other than a cordless type) during an electrical storm. There may be a remote risk of electric shock from lightning.
 - o)** Do not use the telephone to report a gas leak in the vicinity of the leak.

Attention

- Keep the unit away from heating appliances and electrical noise generating devices such as fluorescent lamps, motors and televisions. These noise sources can interfere with the performance of the Digital Super Hybrid System.
- This unit should be kept free of dust, moisture, high temperature (more than 40 °C) and vibration, and should not be exposed to direct sunlight.
- Never attempt to insert wires, pins, etc. into the vents or other holes of this unit.
- If there is any trouble, disconnect the unit from the telephone line. Plug the telephone directly into the telephone line. If the telephone operates properly, do not reconnect the unit to the line until the trouble has been repaired. If the telephone does not operate properly, chances are that the trouble is in the telephone system, and not in the unit.
- Do not use benzine, thinner, or the like, or any abrasive powder to clean the cabinet. Wipe it with a soft cloth.
- The ISDN Line Unit (e.g. KX-TD280) is in accordance with the European Telecommunication Standards (ETS).
If your telephone company provides an ISDN service which follows the standards other than ETS, some ISDN features in the Features Guide may not work properly. (e.g. Charge Fee Reference, CLIP, COLP, etc.)
- To use the point-to-multi-point configuration with the KX-TD286, the number on the name plate, which is on the back of the unit, must be ④ or later.

WARNING

THIS UNIT MAY ONLY BE INSTALLED AND SERVICED BY QUALIFIED SERVICE PERSONNEL.

WHEN A FAILURE OCCURS WHICH RESULTS IN THE INTERNAL PARTS BECOMING ACCESSIBLE, DISCONNECT THE POWER SUPPLY CORD IMMEDIATELY AND RETURN THIS UNIT TO YOUR DEALER.

DISCONNECT THE TELECOM CONNECTION BEFORE DISCONNECTING THE POWER CONNECTION PRIOR TO RELOCATING THE EQUIPMENT, AND RECONNECT THE POWER FIRST.

THIS UNIT IS EQUIPPED WITH AN EARTHING CONTACT PLUG. FOR SAFETY REASONS THIS PLUG MUST ONLY BE CONNECTED TO AN EARTHING CONTACT SOCKET WHICH HAS BEEN INSTALLED ACCORDING TO REGULATIONS.

THE POWER SUPPLY CORD IS USED AS THE MAIN DISCONNECT DEVICE, ENSURE THAT THE SOCKET-OUTLET IS LOCATED / INSTALLED NEAR THE EQUIPMENT AND IS EASILY ACCESSIBLE.

TO PREVENT FIRE OR SHOCK HAZARD, DO NOT EXPOSE THIS PRODUCT TO RAIN OR MOISTURE.

The serial number of this product may be found on the label affixed to the bottom of the unit. You should note the serial number of this unit in the space provided and retain this book as a permanent record of your purchase to aid in identification in the event of theft.

MODEL NO.: _____

SERIAL NO.: _____

For your future reference

SERIAL NO. _____
(found on the bottom of the unit)

DATE OF PURCHASE _____

NAME OF DEALER _____

DEALER'S ADDRESS _____

DEALER'S TEL. NO. _____

Introduction

About this Installation Manual

This Installation Manual provides technical information for the Panasonic Digital Super Hybrid System, KX-TD816 / KX-TD1232. It is designed to serve as an overall technical reference for the system and includes a description of the system, its hardware and software, features and services and environmental requirements.

This manual contains the following sections:

Section 1, System Outline

Provides general information on the system including system capacity and specifications.

Section 2, General Installation

Contains the basic system installation and wiring instructions, as well as how to install the optional cards and units.

Section 3, ISDN Installation

Contains the ISDN unit installation and wiring instructions.

Section 4, E&M Installation

Contains the E&M unit installation and wiring instructions.

Section 5, DECT Installation

Contains the wireless system installation and wiring instructions.

Section 6, Troubleshooting

Provides information for system and telephone troubleshooting.

Section 7, Index

Provides the important words and phrases to help you access the required information easily.

Terms used in this Installation Manual

Programming Guide References

The related and required programming titles described in the *Programming Guide* are noted for your reference.

Programming Guide reference is also shown in the sentences as follows.

Example: <SYS PRG [109]>

Explanation: Refer to system programme [109] in the Programming Guide.

This helps you know the related and require programming easily for the contents of the sentences.

Features Guide References

The related feature titles described in the *Features Guide* are noted for your reference.

About the other manuals

Along with this Installation Manual, the following manuals are available to help you know the available features, programme and use the KX-TD816 / KX-TD1232 system.

Features Guide

Provides information about the system features.

Programming Guide

Provides system programming instructions.

User Manual

Provides operating instructions for the end users using proprietary telephones, single line telephones, consoles or DECT portable stations.

Table of Contents

1	System Outline	
1.1	System Highlights	14
1.1.1	System Highlights	14
1.2	Basic System Construction	16
1.2.1	Basic System Construction	16
1.2.2	System Connection Diagram	17
1.3	Proprietary Telephones	21
1.3.1	Proprietary Telephones	21
1.4	Options	22
1.4.1	Options	22
1.4.2	Expansion Unit Combination	25
1.5	Specifications	27
1.5.1	General Description	27
1.5.2	Characteristics	29
1.5.3	System Capacity	30
2	General Installation	
2.1	Before Installation	34
2.1.1	Before Installation	34
2.2	Installation of the Main Unit	36
2.2.1	Unpacking	36
2.2.2	Location of Interfaces	37
2.2.3	Wall Mounting	39
2.2.4	Frame Ground Connection	41
2.2.5	Opening the Front Cover	42
2.3	Connection	43
2.3.1	Outside Line Connection	43
2.3.2	Extension Connection	45
2.3.3	Paralleled Telephone Connection	52
2.3.4	EXtra Device Port (XDP) Connection	54
2.3.5	Polarity Sensitive Telephone Connection	55
2.3.6	External Pager (Paging Equipment) Connection	57
2.3.7	External Music Source Connection	60
2.3.8	Printer and PC Connection	63
2.3.9	Installation of Lightning Protectors	66
2.4	Installation of Optional Cards and Unit	69
2.4.1	Location of Optional Cards and Units	69
2.4.2	4-CO Line Unit Connection	74
2.4.3	8-Station Line Unit Connection	75
2.4.4	16 SLT Line Circuit Unit	76
2.4.5	Installing Expansion Unit	77
2.4.6	Pay Tone Card Installation	84
2.4.7	DISA Card / Unit and Remote Card / Unit Installation	87
2.4.8	Doorphone and Door Opener Connection	94
2.4.9	SLT Message Waiting Lamp Adaptor Unit Connection	99
2.4.10	System Connection	107

2.4.11	Battery Adaptor Connection.....	109
2.5	Auxiliary Connection for Power Failure Transfer.....	112
2.5.1	Auxiliary Connection for Power Failure Transfer.....	112
2.6	Closing the Front Cover.....	114
2.6.1	Closing the Front Cover	114
2.7	Starting the System for the First Time	116
2.7.1	Starting the System for the First Time.....	116
2.8	System Restart	118
2.8.1	System Restart.....	118
2.9	System Data Clear	119
2.9.1	System Data Clear	119
3	ISDN Installation	
3.1	ISDN Network Outline.....	122
3.1.1	Overview	122
3.2	ISDN Line Connection	123
3.2.1	Location of the Units.....	123
3.2.2	Installing the Unit.....	125
3.2.3	Internal ISDN S0 Line Connection	130
4	E & M Installation	
4.1	E & M (TIE) Line Service Outline.....	134
4.1.1	Overview	134
4.1.2	Specifications	135
4.2	E & M (TIE) Line Installation	136
4.2.1	Location of the Unit.....	136
4.2.2	Installing the Unit.....	138
4.2.3	E&M (TIE) Line Connection	142
5	DECT Installation	
5.1	Wireless System Outline	148
5.1.1	Overview	148
5.1.2	RF Specifications.....	149
5.1.3	Procedure Flow Chart.....	150
5.2	Wireless System Installation.....	151
5.2.1	Site Planning.....	151
5.2.2	Location of the Unit.....	154
5.2.3	Installing the Unit.....	158
5.2.4	Selecting the Display Language.....	165
5.2.5	Site Survey.....	166
5.2.6	Wall Mounting.....	175
6	Troubleshooting	
6.1	Troubleshooting	178
6.1.1	Installation	178
6.1.2	Connection.....	179
6.1.3	Operation	181
6.1.4	Using the Reset Button.....	182
7	Index	185



Section 1
System Outline

1.1 System Highlights

1.1.1 System Highlights

System Maximum Capacity

		KX-TD816	KX-TD1232	KX-TD1232 x 2
Extension	PT & SLT* ¹	16 (XDP* ² : 32)	32 (XDP: 64)	64 (XDP: 128)
	ISDN telephone	6 BRI (12 ch)	6 BRI (12 ch)	12 BRI (24 ch)
	DECT portable station	16	64	64
Outside Line	Analogue	8	12	24
	Basic Rate Interface (BRI)	4 BRI (8 ch)	6 BRI (12 ch)	12 BRI (24 ch)
	Primary Rate Interface (PRI)	—	1 PRI (30 ch)	1 PRI (30 ch)

*¹ Proprietary telephone and single line telephone

*² EXtra Device Port

Module Expansion

Expansion modules are used to increase the system capacity.

EXtra Device Port (XDP)

Each extension jack in the system supports the connection of a digital proprietary telephone / console and a single line device. The two devices per jack have different extension numbers and are treated as two completely different extensions.

Paralleled Telephone Connection

Every jack in the system also supports the parallel connection of a proprietary telephone and a single line device. They share the same extension number and are considered by the system to be one extension.

Super Hybrid System

This system supports the connection of digital and analogue proprietary telephones, DSS Consoles and single line devices such as single line telephones, fax machines, and data terminals.

System Connection^{*1}

With the addition of the optional System Inter Connection Card, two Digital Super Hybrid Systems can be connected together to double the capacity of the system. The two systems function as one, therefore, some functions such as paging and music-on-hold are duplicated.

ISDN Line Service

The system can manage a call received from the ISDN line by point-to-point or point-to-multi-point configuration. To use this service, an optional unit is required.

E&M (TIE) Line Service

An E&M (TIE) line is a privately leased communication line between two or more PBXs, which provides cost effective communications between company at different locations. To use this service, an optional unit is required.

Wireless System

The system supports the connection of a DECT portable station which can be used as an wireless extension. To support the portable station, optional units are required.

^{*1} Available for the KX-TD1232 only.

1.2 Basic System Construction

1.2.1 Basic System Construction

The KX-TD816 Digital Super Hybrid System has a basic capacity of four outside lines and eight extensions, and the KX-TD1232 has eight outside lines and 16 extensions. They are capable of supporting Panasonic digital and analogue proprietary telephones, consoles and single line devices such as single line telephones and fax machines.

To expand its capabilities the system can be equipped with optional components or customer-supplied peripherals such as external speakers and external music sources (e.g. radios).

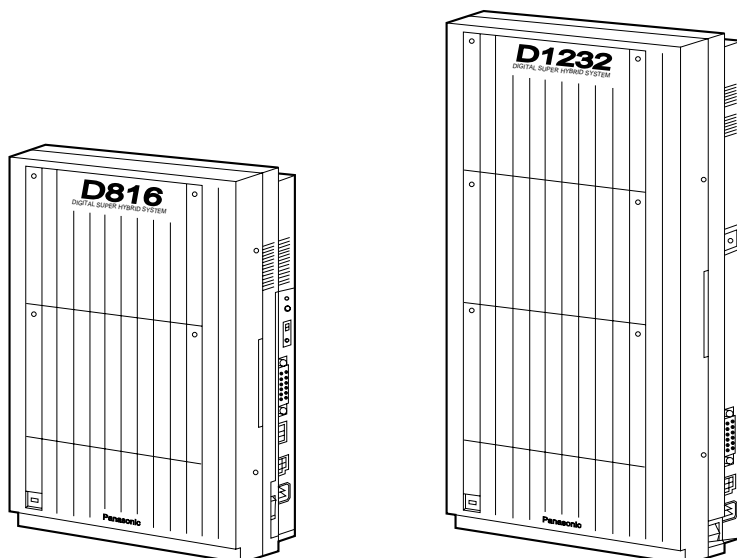

1.2.2 System Connection Diagram

KX-TD816

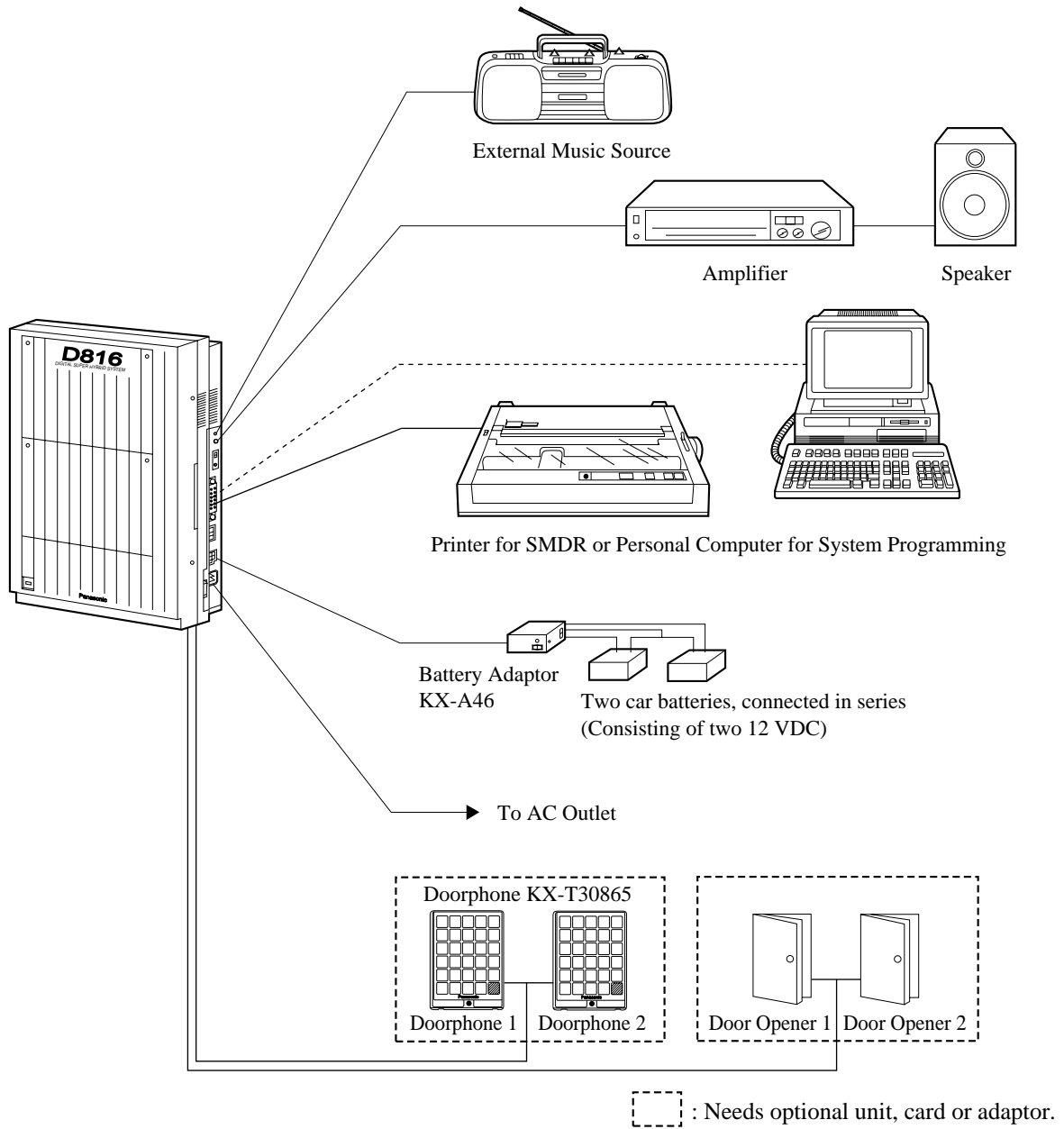

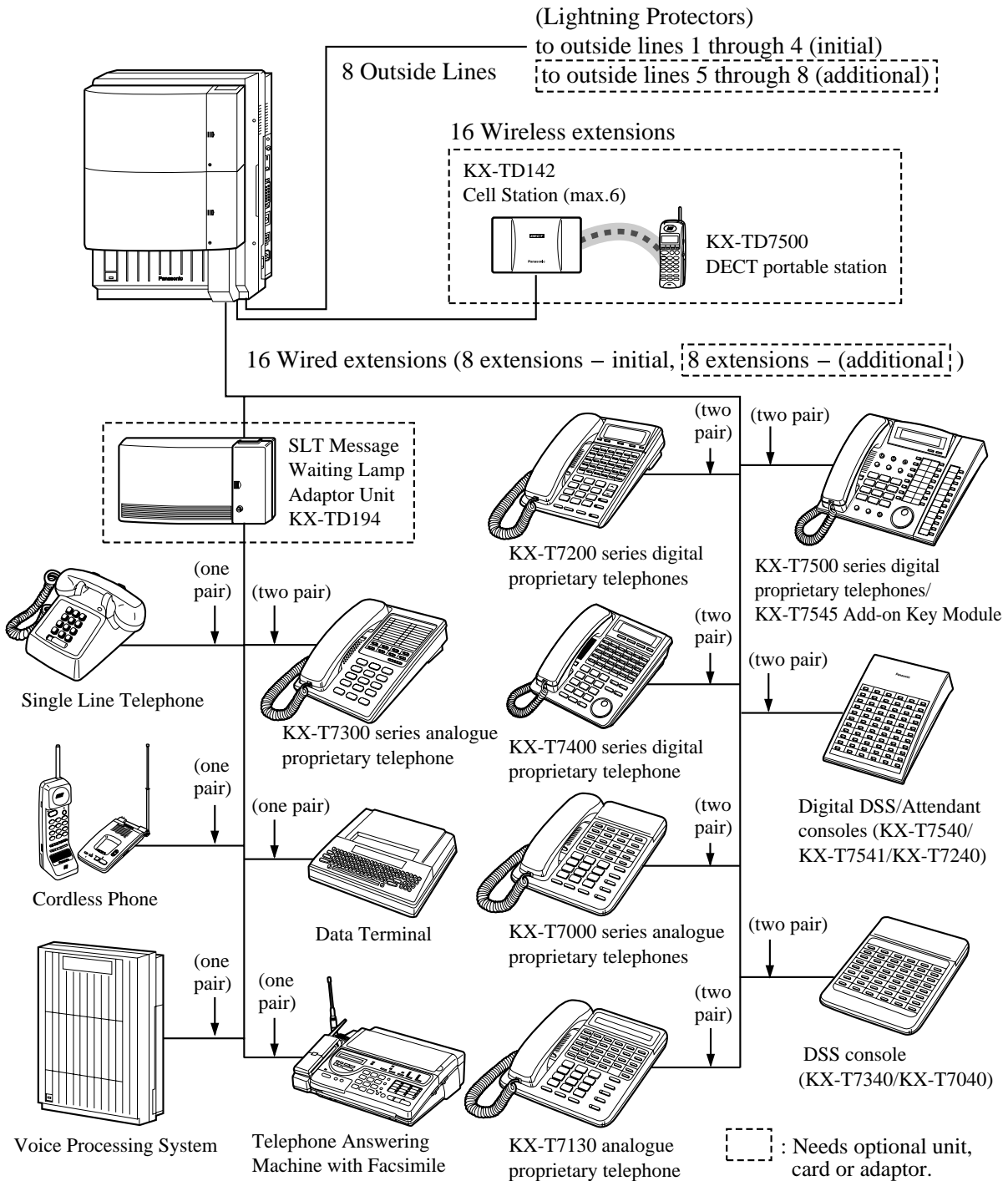

Note

- It is recommended that extension of jack 1 is a display proprietary telephone.
- Parallel connection of telephones is possible. Refer to Section 2.3.3 Parallelled Telephone Connection.

KX-TD1232

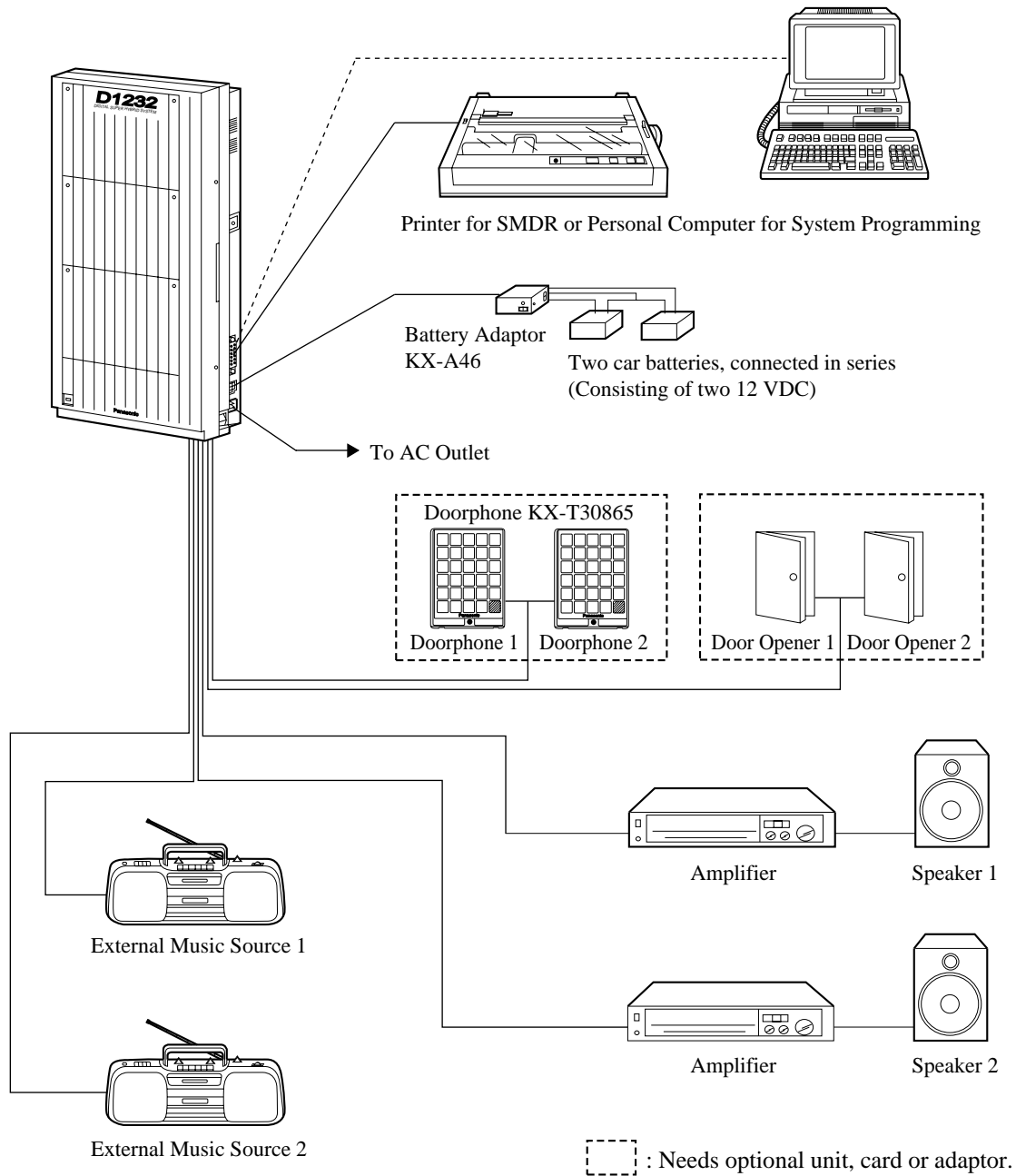

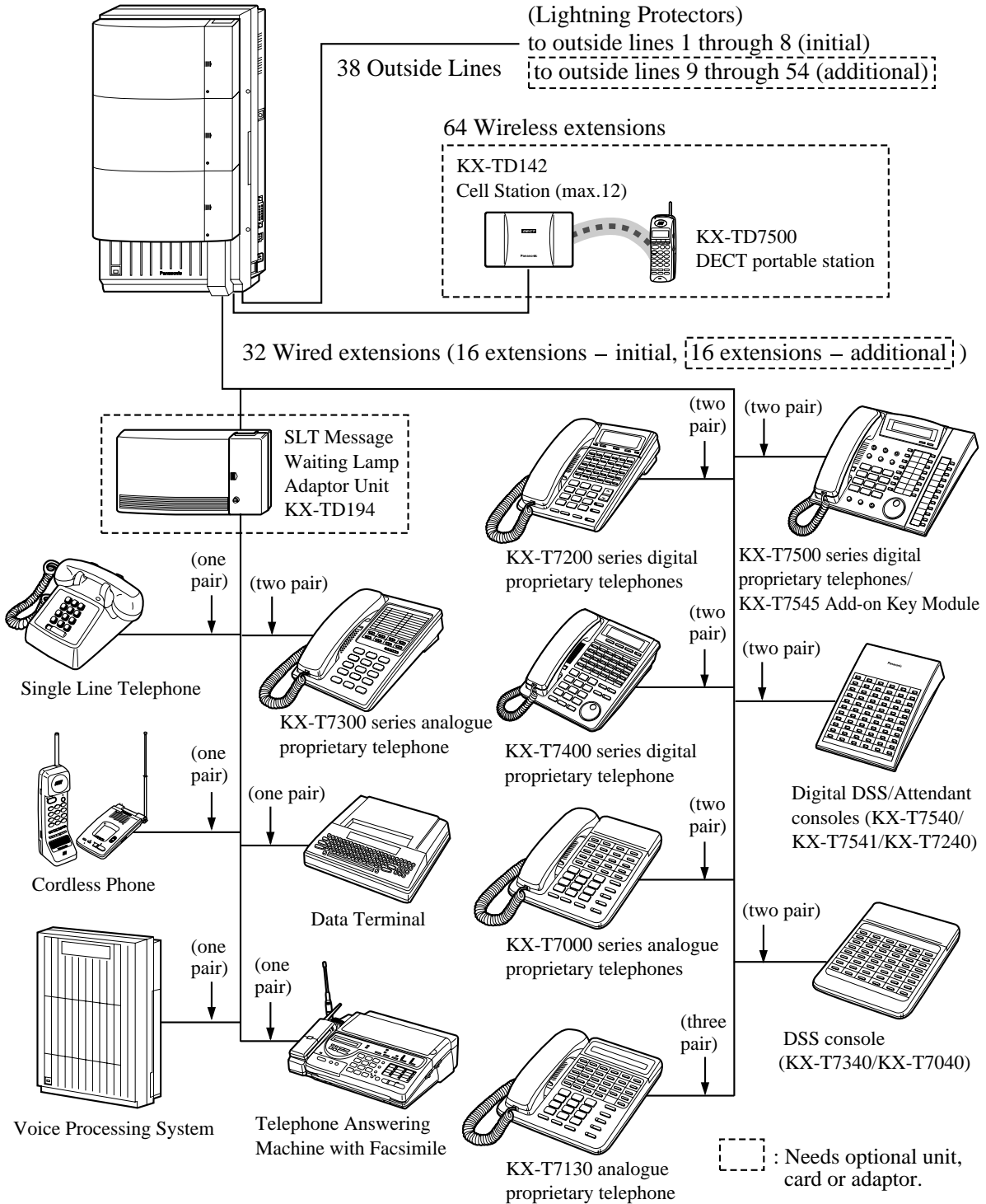

Note

- It is recommended that extension of jack 1 is a display proprietary telephone.
- Parallel connection of telephones is possible. Refer to Section 2.3.3 Paralleled Telephone Connection.

1.3 Proprietary Telephones

1.3.1 Proprietary Telephones

The following Panasonic proprietary telephones are available with this system.

Proprietary Telephone	Description
KX-T7520	Digital, speakerphone, Jog Dial, 12 Flexible CO
KX-T7531	Digital, 1-line display, speakerphone, Jog Dial, 12 Flexible CO
KX-T7533	Digital, 3-line display, speakerphone, Jog Dial, 12 Flexible CO
KX-T7536	Digital, 6-line display, speakerphone, Jog Dial, 12 Flexible CO
KX-T7550	Digital, monitor, Jog Dial, 12 Flexible CO
KX-T7425	Digital, speakerphone, Jog Dial, 24 Flexible CO
KX-T7433	Digital, 3-line display, speakerphone, Jog Dial, 24 Flexible CO
KX-T7436	Digital, 6-line display, speakerphone, Jog Dial, 24 Flexible CO
KX-T7450	Digital, monitor, Jog Dial, 12 Flexible CO
KX-T7220	Digital, speakerphone, 24 Flexible CO
KX-T7230	Digital, 2-line display, speakerphone, 24 Flexible CO
KX-T7235	Digital, 6-line display, speakerphone, 12 Flexible CO
KX-T7250	Digital, monitor, 6 Flexible CO
KX-T7320	Speakerphone, 12 Flexible CO
KX-T7330	1-line display, speakerphone, 12 Flexible CO
KX-T7350	Monitor, 12 Flexible CO
KX-T7130	1-line display, speakerphone, 12 Flexible CO, 12 PF
KX-T7020	Speakerphone, 12 Flexible CO, 4 PF
KX-T7030	1-line display, speakerphone, 12 Flexible CO, 4 PF
KX-T7033	1-line display, speakerphone, 12 Flexible CO, 4 PF
KX-T7050	Monitor, 12 Flexible CO, 4 PF
KX-T7055	Monitor, 3 Flexible CO, 4 PF
KX-TD7500	Digital, wireless, 3 Flexible CO

Note

- Flexible CO : Flexible CO button (programmable)
- PF : Programmable Feature button

1.4 Options

1.4.1 Options

Model No.	Model Name	Description	Max. Quantity on KX-TD816	Max. Quantity on KX-TD1232	
				Single System	System Connection
KX-TD170	8-Station Line Unit	Adds 8 extension lines.	1	2	4
KX-TD174	16 SLT Line Circuit Unit	Adds 16 extension lines which contain single line telephones.	1	2	4
KX-TD180	4-CO Line Unit	Adds 4 outside lines.	1	1	2
KX-TD184	E&M (TIE) Line Unit	Adds 4 ports for E&M Line Service.	1	1	2
KX-TD280	2-ISDN S0 Line Unit	Adds 2 ISDN S0 lines.	1	1	2
KX-TD286	6-ISDN S0 Line Unit	Adds 6 ISDN S0 lines.	1	1	2
KX-TD290	Primary Rate Interface ISDN Expansion Unit	Adds 1 PRI ISDN line.	—	1	1
KX-TD144	Cell Station Interface Unit	Supports up to two Cell Stations (KX-TD142).	1	2	2
KX-TD146	Cell Station Interface Unit	Supports up to six Cell Stations (KX-TD142).	1	2	2
KX-TD142	Cell Station	Determines the range of the supporting DECT Portable Station (KX-TD7500). Up to four calls can be made at the same time in one range.	(6 per Cell Station Interface Unit)	(6 per Cell Station Interface Unit)	(6 per Cell Station Interface Unit)
KX-TD189	Pay Tone Card	Supports the Pay Tone service of the central office.	2*	3*	6*
KX-TD190	DISA Unit	Supports the Direct Inward System Access (DISA) feature and records outgoing messages.	1	—	—

Model No.	Model Name	Description	Max. Quantity on KX-TD816	Max. Quantity on KX-TD1232	
				Single System	System Connection
KX-TD191	DISA Card	Supports the Direct Inward System Access (DISA) feature and records outgoing messages.	—	1	2
KX-TD192	System Inter Connection Card	Connects two Digital Super Hybrid Systems.	—	—	2
KX-TD194	SLT Message Waiting Lamp Adaptor Unit	Supports the Message Waiting feature for a single line telephone with a message waiting lamp. One unit supports 16 extensions.	1	3	6
KX-TD196	Remote Card	Supports the programming and maintenance of the system from a remote location.	—	1	2
KX-TD197	High Speed Remote Card	Supports the programming and maintenance of the system from a remote location. This card can also be installed in the KX-TD190, DISA Unit, for the KX-TD816.	(1 per KX-TD190)	1	2
KX-TD198	Remote Unit	Supports the programming and maintenance of the system from a remote location.	1	—	—
KX-TD199	DISA Card	Supports the Direct Inward System Access (DISA) feature and records an Outgoing Message. This card can only be installed in the KX-TD198, Remote Unit.	(1 per KX-TD198)	—	—

Model No.	Model Name	Description	Max. Quantity on KX-TD816	Max. Quantity on KX-TD1232	
				Single System	System Connection
KX-TD160	Doorphone Card	Supports 2 doorphones (KX-T30865) and 2 door openers.	1	1	2
KX-A277	AC Adaptor	Required when installing the Cell Station Interface Unit, KX-TD146.	—	—	—
KX-A46	Battery Adaptor	Supports the connection of two car batteries for power backup in the event of a power failure.	1	1	2
KX-T7540 / KX-T7440 / KX-T7240	Digital DSS Console	Provides easy and quick access to extensions and features. This must be used with a proprietary telephone.	4	4	8
KX-T7541	Digital Attendant Console				
KX-T7441	DSS Console for Attendant				
KX-T7040 / KX-T7340	DSS Console				
KX-T7545	Add-on Key Module	Adds 12 CO buttons to a KX-T7500 series digital proprietary telephone.	—	—	—
KX-T30865	Doorphone	Used for a doorphone call.	2	2	4

* One KX-TD189 can be connected to every four CO (outside line) ports.

1.4.2 Expansion Unit Combination

KX-TD816

	KX-TD14x	KX-TD17x	KX-TD18x	KX-TD28x	KX-TD290
Basic (no unit connected)	○	○	○	○	×
KX-TD14x	×	×	○	○	×
KX-TD17x		×	○	○	×
KX-TD18x			×	×	×
KX-TD28x				×	×
KX-TD290					×

KX-TD1232 Master System

	KX-TD14x	KX-TD17x	KX-TD18x	KX-TD28x	KX-TD290
Basic (no unit connected)	○	○	○	○	○
KX-TD14x	○	○	○	○	○
KX-TD17x		○	○	○	○
KX-TD18x			×	×	×
KX-TD28x				×	○
KX-TD290					×
KX-TD14x + KX-TD14x	×	×	○	○	○
KX-TD14x + KX-TD17x		×	○	○	○
KX-TD14x + KX-TD18x			×	×	×
KX-TD14x + KX-TD28x				×	○
KX-TD14x + KX-TD290					×
KX-TD17x + KX-TD17x		×	○	○	○
KX-TD17x + KX-TD18x			×	×	×
KX-TD17x + KX-TD28x				×	○
KX-TD17x + KX-TD290					×

KX-TD1232 Slave System

	KX-TD14x	KX-TD17x	KX-TD18x	KX-TD28x	KX-TD290
Basic (no unit connected)	×	○	○	○	×
KX-TD17x		○	○	○	×
KX-TD18x			×	×	×
KX-TD28x				×	×
KX-TD17x + KX-TD17x		×	○	○	×
KX-TD17x + KX-TD18x			×	×	×
KX-TD17x + KX-TD28x				×	×

Note

- : Combination possible; ×: Combination not possible;
Shaded part: These combinations shown elsewhere in the table.
x: Any number (e.g. KX-TD28x can be KX-TD280 or KX-TD286)
- The KX-TD14x and KX-TD290 can only be connected to the Master system.
- If the KX-TD290 is connected, no outside lines on the Slave system can be used.

1.5 Specifications

1.5.1 General Description

Control Method		CPU: 16-bit CPU
Switching		Non Blocking PCM Time Switch
Power Supplies	Primary	KX-TD816: 220 VAC – 230 VAC, 50 Hz KX-TD1232: 220 – 240 VAC, 50 Hz / 60 Hz
	Secondary	Station Supply Volt: 30 V Circuit Volt: ± 5 V, ± 15 V
	Power Failure	<ul style="list-style-type: none"> • Memory backup duration: seven years with a factory-provided lithium battery • 4 outside lines max. for KX-TD816 and 6 outside lines max. for KX-TD1232 automatically assigned to extensions (Power Failure Transfer) • System operation for about three hours using recommended batteries (consisting of two 12 VDC car batteries)
Dialling	Outward	Dial Pulse (DP) 10 pps, 20 pps Tone (DTMF) Dialling
	Internal	Dial Pulse (DP) 10 pps, 20 pps Tone (DTMF) Dialling
Connectors	Outside lines	Modular Jack
	Extensions	KX-TD816: Modular Jack KX-TD1232: Amphenol Connector
	Paging Output	Pin Jack (RCA JACK)
	External Music Input	Two-conductor Jack (MINIJACK 3.5 mm diameter)

Extension Connection Cable	Single line telephones	1 pair wire (T, R)
	KX-T7520, KX-T7531, KX-T7533, KX-T7536, KX-T7550, KX-T7425, KX-T7433, KX-T7436, KX-T7450, KX-T7220, KX-T7230, KX-T7235, KX-T7250	1 pair wire (D1, D2) or 2 pair wire (T, R, D1, D2)
	KX-T7320, KX-T7330, KX-T7350, KX-T7130 (with the KX-TD816), KX-T7020, KX-T7030, KX-T7033, KX-T7050, KX-T7055	2 pair wire (T, R, D1, D2)
	KX-T7130 (with the KX-TD1232)	3 pair wire (T, R, D1, D2, P1, P2)
	KX-T7540, KX-T7541, KX-T7440, KX-T7441, KX-T7240, KX-T7340, KX-T7040	1 pair wire (D1, D2)
Station Message Detail Recording (SMDR)	Interface	Serial Interface (RS-232C)
	Output Equipment	Printer

1.5.2 Characteristics

Station Loop Limit	Proprietary Telephone: 40 Ω Single Line Telephone: 600 Ω including set Doorphone: 20 Ω
Minimum Leakage Resistance	15 000 Ω
Maximum Number of Station Instruments per Line	1 for proprietary telephone or single line telephone 2 by Parallel or eXtra Device Port Connection of a proprietary telephone and a single line telephone or by Super eXtra Device Port Connection of a wired telephone (proprietary or single line telephone) and a DECT portable station
Ring Voltage	70 Vrms at 25 Hz depending on the Ringing Load
Central Office Loop Limit	1 600 Ω max.
Environmental Requirements	0°C – 40°C, 10 – 90% relative humidity
Hookswitch Flash Timing Range	84 ms – 1000 ms

1.5.3 System Capacity

Line

Actual capacity will depend on the number or/and type of units connected to the system.

		KX-TD816	KX-TD1232	KX-TD1232 x 2
Extension	PT & SLT* ¹	16 (XDP* ² : 32)	32 (XDP: 64)	64 (XDP: 128)
	ISDN telephone	6 BRI (12 ch)	6 BRI (12 ch)	12 BRI (24 ch)
	DECT portable station	16	64	64
Outside Line	Analogue	8	12	24
	Basic Rate Interface (BRI)	4 BRI (8 ch)	6 BRI (12 ch)	12 BRI (24 ch)
	Primary Rate Interface (PRI)	—	1 PRI (30 ch)	1 PRI (30 ch)

*¹ Proprietary telephone and single line telephone

*² EXtra Device Port

User-supplied Equipment

Item	Max. Quantity on KX-TD816	Max. Quantity on KX-TD1232	
		Single System	System Connection
Doorphones	2	2	4
Door Openers	2	2	4
External Pagers	1	2	4
External Music Source	1	2	4

System Data

Item	Max. Quantity
Operators	2
System Speed Dialling	500
One-Touch Dialling	24 per extension (proprietary telephone)
Station Speed Dialling	10 per extension
Call Park areas	10
Absent Messages	9
Outside Line Groups	8
Toll Restriction Levels	8
Extension Groups	8
Class of Service	8
Message Waitings	128
Uniform Call Distribution Groups	8

Section 2
General Installation

2.1 Before Installation

2.1.1 Before Installation

Please read the following notes concerning installation and connection before installing the system and terminal equipment.

Safety Installation Instructions

When installing telephone wiring, basic safety precautions should always be followed to reduce the risk of fire, electric shock and injury to persons, including the following:

- a) Never install telephone wiring during a lightning storm.
- b) Never install telephone jacks in wet locations unless the jack is specifically designed for wet locations.
- c) Never touch uninsulated telephone wires or terminals unless the telephone line has been disconnected at the network interface.
- d) Use caution when installing or modifying telephone lines.

Installation Precautions

This system is designed for wall mounting only. Avoid installing in the following places. (Doing so may result in malfunction, noise, or discoloration.)

- a) In direct sunlight and hot, cold, or humid places. (Temperature range: 0°C – 40°C)
- b) Sulfuric gases produced in areas where there are thermal springs, etc. may damage the equipment or contacts.
- c) Places in which shocks or vibrations are frequent or strong.
- d) Dusty places, or places where water or oil may come into contact with the system.
- e) Near high-frequency generating devices such as sewing machines or electric welders.
- f) On or near computers, telexes, or other office equipment, as well as microwave ovens or air conditioners. (It is preferable not to install the system in the same room with the above equipment.)
- g) Install at least 1.8 m away from radios and televisions. (Both the system and Panasonic proprietary telephones)
- h) Do not obstruct area around the system (for reasons of maintenance and inspection — be especially careful to allow space for cooling above and at the sides of the system).

Wiring Precautions

Be sure to follow these instructions when wiring the unit:

- a) Do not wire the telephone cable in parallel with an AC power source, computer, telex, etc. If the cables are run near those wires, shield the cables with metal tubing or use shielded cables and ground the shields.
- b) If cables are run on the floor, use protectors to prevent the wires from being stepped on. Avoid wiring under carpets.
- c) Avoid using the same power supply outlet for computers, telexes, and other office equipment. Otherwise, the system operation may be interrupted by the induction noise from such equipment.
- d) Please use one pair telephone wire for extension connection of (telephone) equipment such as single line telephones, data terminals, answering machines, computers, voice processing systems, etc., except Panasonic proprietary telephones (e.g. KX-T7536, KX-T7235).
- e) The Power Switch of the system must be off during wiring. After all of the wiring is completed, turn the Power Switch on.
- f) Mis-wiring may cause the system to operate improperly. Refer to Section 6.1.1 Installation and 6.1.2 Connection.
- g) If an extension does not operate properly, disconnect the telephone from the extension line and then connect again, or turn off the Power Switch of the system and then on again.
- h) The system is equipped with a 3-wire grounding type plug. This is a safety feature. If you are unable to insert the plug into the outlet, contact your electrician to replace your obsolete outlet. Do not defeat the purpose of the grounding-type plug.
- i) Use twisted pair cable for outside line connection.
- j) Outside lines should be installed with lightning protectors. For details, refer to Section 2.3.9 Installation of Lightning Protectors.

WARNING

Static sensitive devices are used. To protect printed circuit boards from static electricity, do not touch connectors indicated to the right. To discharge body static, touch ground or wear a grounding strap.

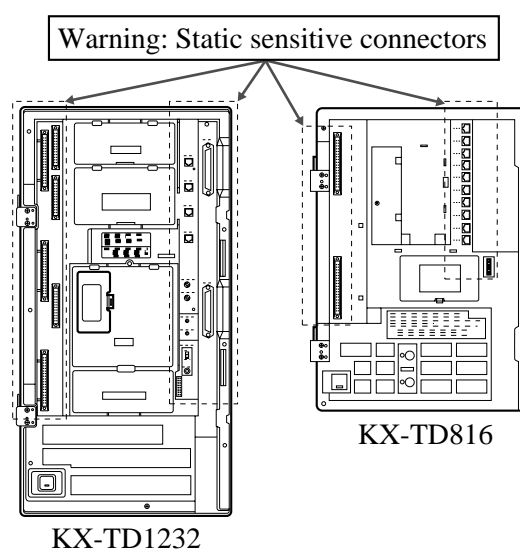

2.2 Installation of the Main Unit

2.2.1 Unpacking

Unpack the box and check the items below:

	KX-TD816	KX-TD1232
Main Unit	one	one
AC Cord	one	one
Template	one	one
Screws (Wall Mounting)	three	four
Anchor Plug	three	four
Pager Connectors	—	two
Music Source Connectors	—	two
Expansion Line Cord Holder	one	one

2.2.2 Location of Interfaces

Overview

KX-TD816

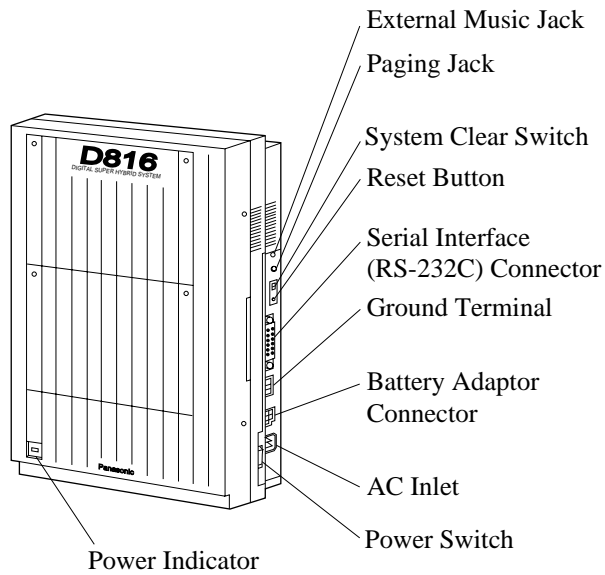

KX-TD1232

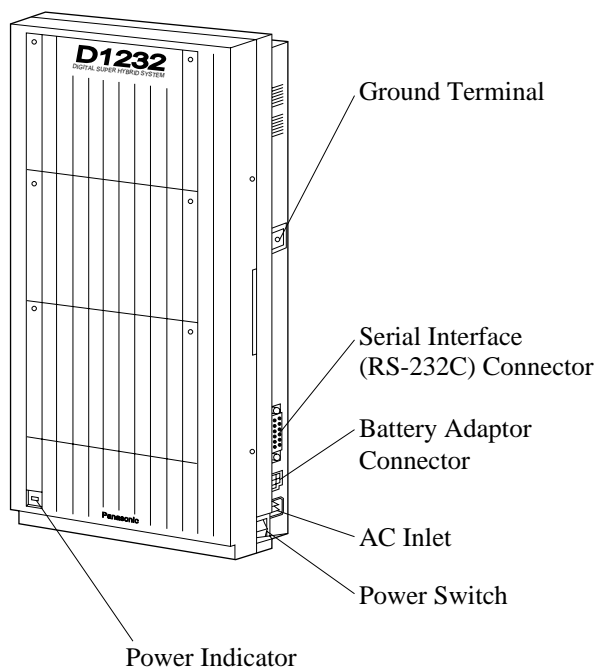

**Inside View
KX-TD816**

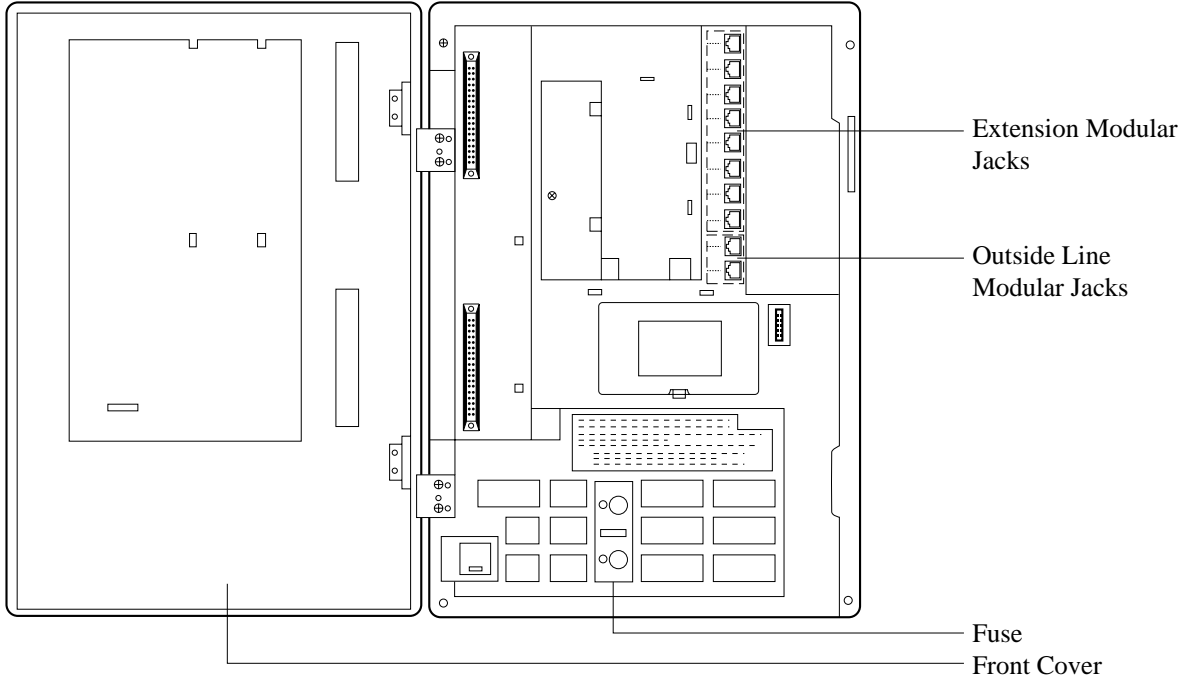

KX-TD1232

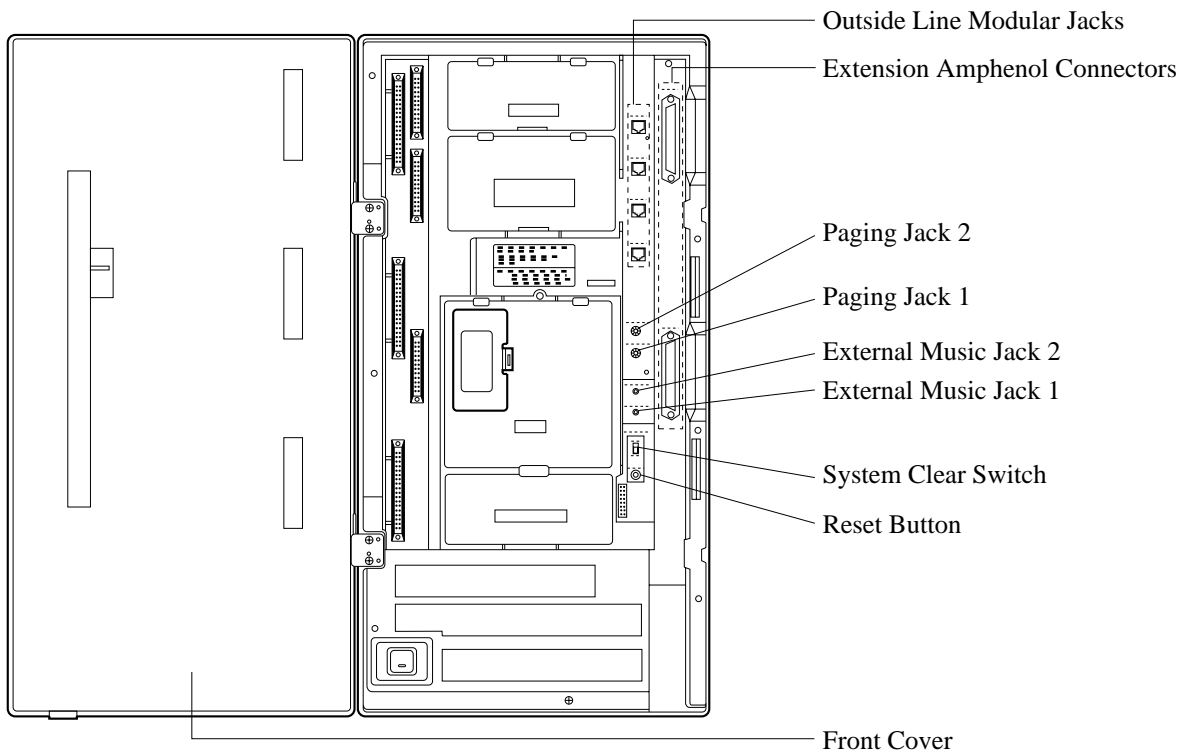

2.2.3 Wall Mounting

This set is designed for wall mounting only. The wall where the main unit is to be mounted must be able to support the weight of the main unit. If screws other than the ones supplied are used, use screws with the same diameter as the ones enclosed.

Mounting on Wooden Wall

1. Place the template (included) on the wall to mark the screw positions.

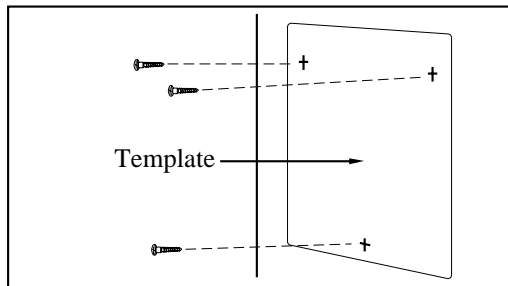

KX-TD816

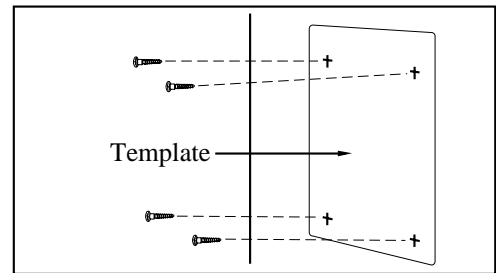

KX-TD1232

2. Install the screws (included) into the wall.

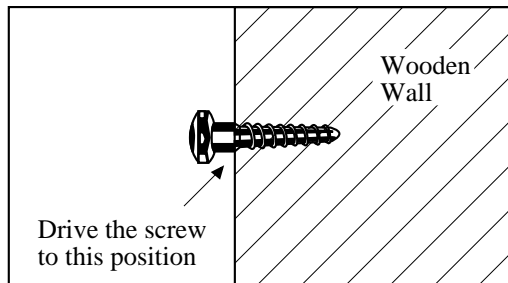

3. Hook the main unit on the screw heads.

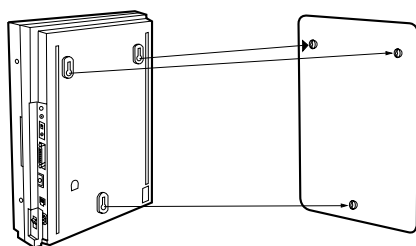

KX-TD816

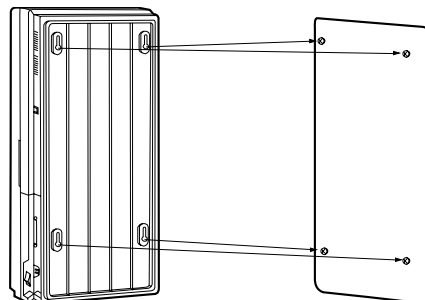

KX-TD1232

Mounting on Concrete or Mortar Wall

1. Place the template (included) on the wall to mark the screw positions.

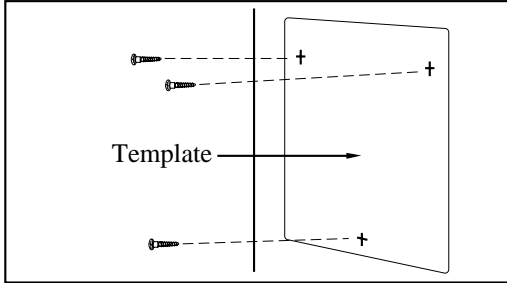

KX-TD816

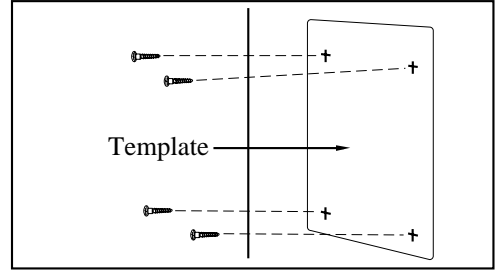

KX-TD1232

2. Drill holes and drive the anchor plug (included) with a hammer, flush to the wall.

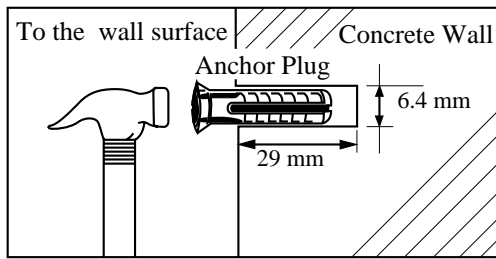

3. Install the screws (included) into the anchor plugs.

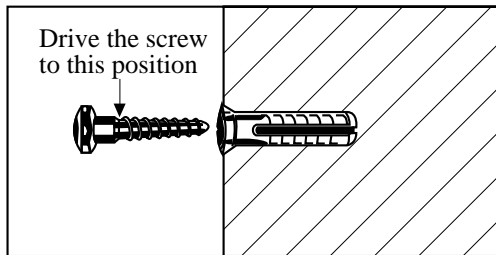

4. Hook the main unit on the screw heads.

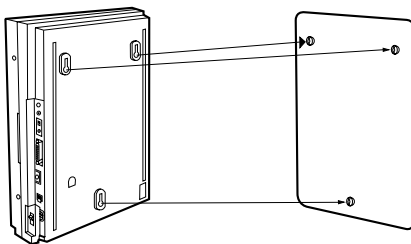

KX-TD816

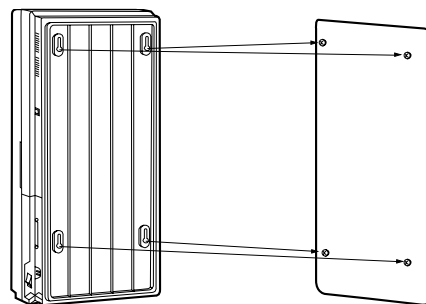

KX-TD1232

2.2.4 Frame Ground Connection

IMPORTANT

Connect the frame of the main unit to ground.

1. Loosen the screw.
2. Insert the grounding wire.
3. Tighten the screw.
4. Connect the grounding wire to ground.

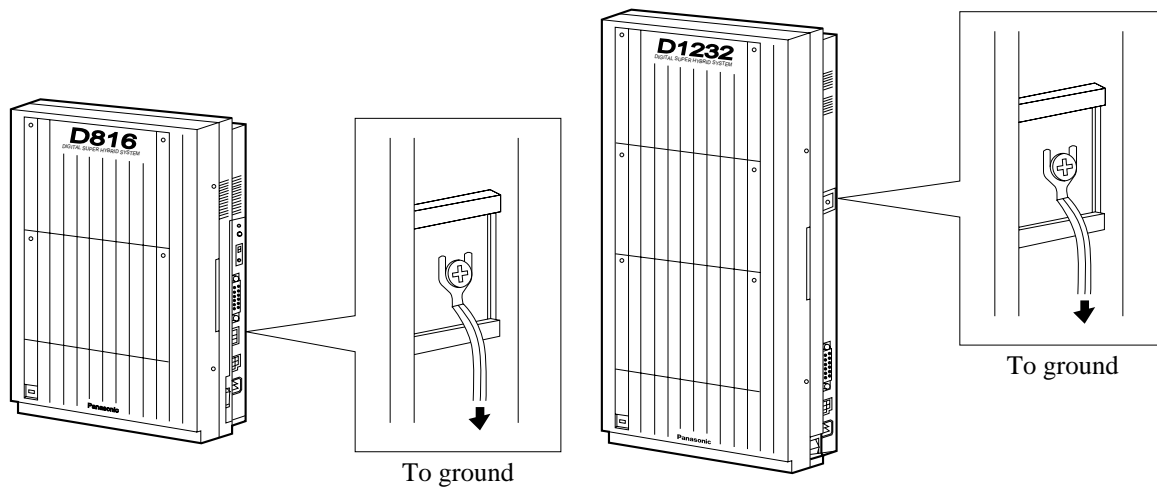

2.2.5 Opening the Front Cover

1. Loosen the two screws on the right side of the main unit.
2. Open the front cover in the direction of arrow ①.

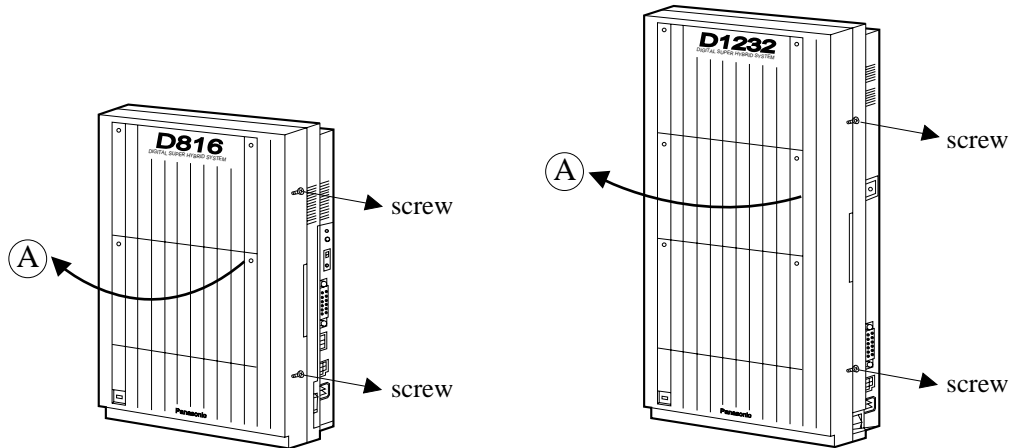

Note

The two screws are attached to the front cover with springs so that they will not be lost.

2.3 Connection

2.3.1 Outside Line Connection

Connection

1. Insert the modular plugs of the telephone line cords (4-conductor wiring) into the modular jacks on the system.
2. Connect the line cord to the terminal board or the Central Office jack.

KX-TD816

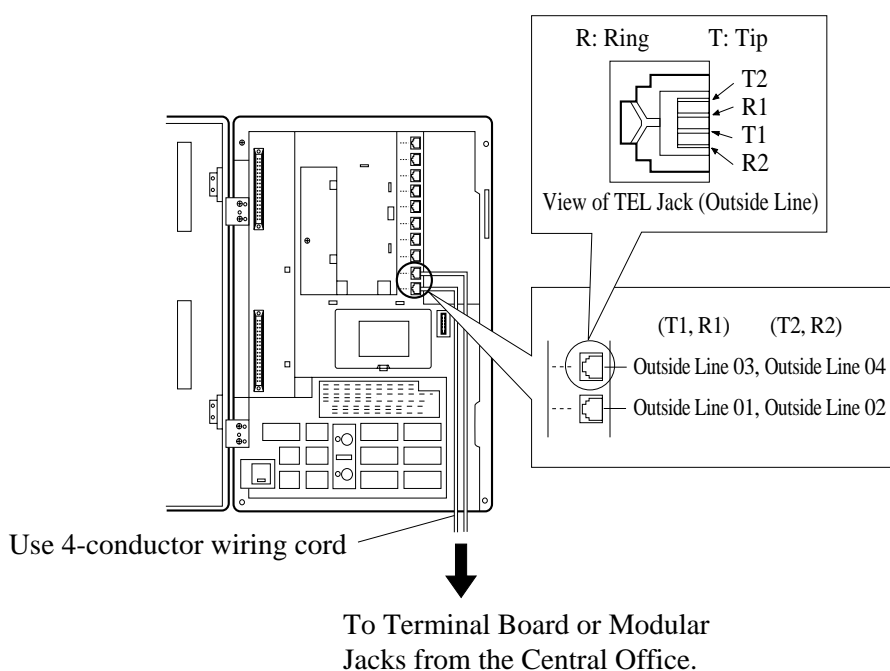

KX-TD1232

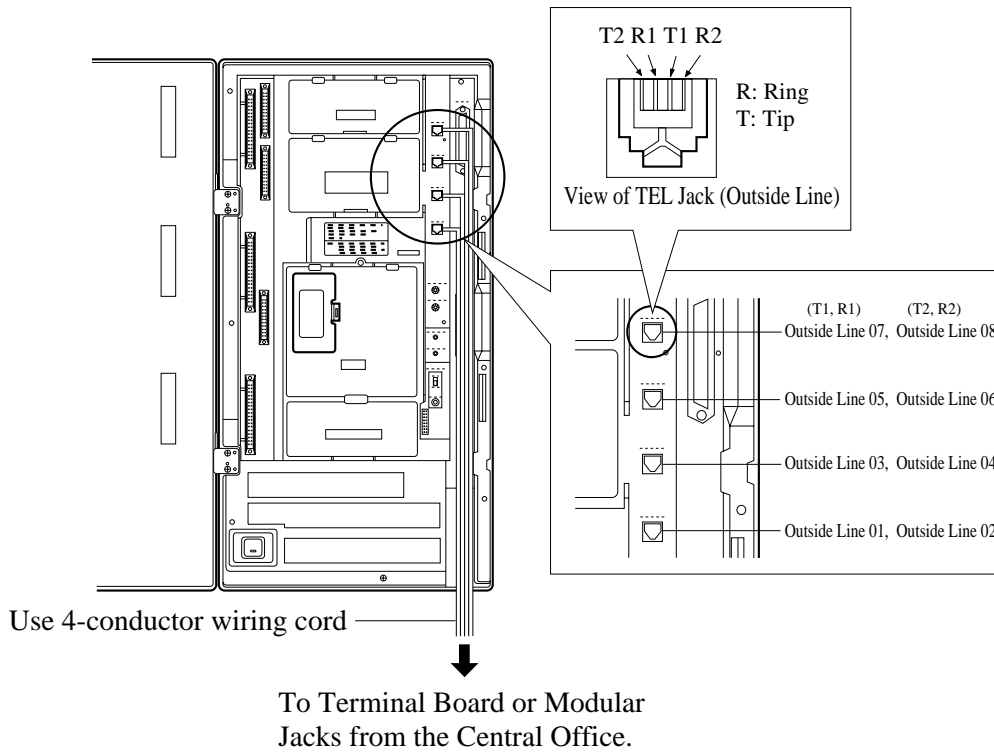

Notice

- Use twisted pair cable for installation.
- Mis-connection may cause the system to operate improperly. See Section 6.1.1 Installation and 6.1.2 Connection.

2.3.2 Extension Connection

KX-TD816

Extension jacks 01 through 08 are for all kinds of telephones.

Maximum Cabling Distance

The maximum length of the extension line cord (twisted cable) which connects the system and the extension is as follows:

	Diameter of the line	Max. length
Single Line Telephone	22 AWG	1798 m
	24 AWG	1128 m
	26 AWG	698 m
Proprietary Telephone / Console	22 AWG	360 m
	24 AWG	229 m
	26 AWG	140 m

Telephone Wiring

2 or 4-conductor wiring is required for each extension as listed below. There are four pins for possible connection: "T", "R", "D1" and "D2".

T: Tip

R: Ring

D1: Data 1

D2: Data 2

Telephone	Wiring
Single Line telephone	1 pair wire (T, R)
Digital proprietary telephone (e.g. KX-T7536, KX-T7235)	1 pair wire (D1, D2) or 2 pair wire (D1, D2, T, R) for eXtra Device Port
Analogue proprietary telephone (e.g. KX-T7030, KX-T7130)	2 pair wire (D1, D2, T, R)
Console (e.g. KX-T7540, KX-T7240)	1 pair wire (D1, D2)

Connection

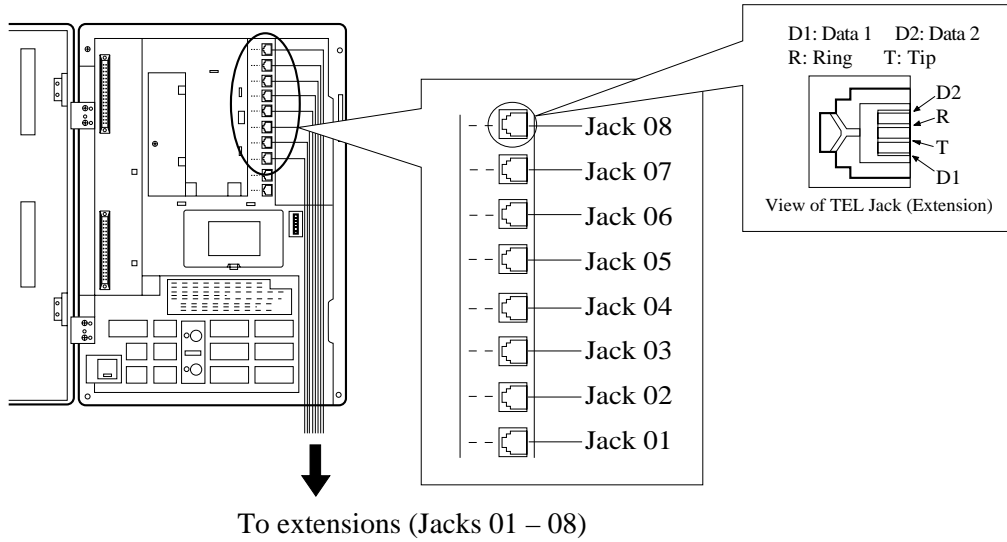

KX-TD1232

Extension jacks 1 through 16 are for all kinds of telephones.

Maximum Cabling Distance

The maximum length of the extension line cord (twisted cable) which connects the system and the extension is as follows:

	Diameter of the line	Max. length
Single Line Telephone	22 AWG	1798 m
	24 AWG	1128 m
	26 AWG	698 m
Proprietary Telephone / Console	22 AWG	360 m
	24 AWG	229 m
	26 AWG	140 m

Telephone Wiring

2, 4 or 6-conductor wiring is required for each extension as listed below. There are six pins for possible connection: "T", "R", "D1", "D2", "P1" and "P2".

- T: Tip
- R: Ring
- D1: Data 1
- D2: Data 2
- P1: 3 Pair Voice (OHCA)
- P2: 3 Pair Voice (OHCA)

Telephone	Wiring
Single Line telephone	1 pair wire (T, R)
Digital proprietary telephone (e.g. KX-T7536, KX-T7235)	1 pair wire (D1, D2) or 2 pair wire (D1, D2, T, R) for eXtra Device Port
Analogue proprietary telephone except KX-T7130 (e.g. KX- T7020, KX-T7030)	2 pair wire (D1, D2, T, R)
KX-T7130 Analogue proprietary telephone	3 pair wire* (D1, D2, T, R, P1, P2)
Console (e.g. KX-T7540, KX-T7240)	1 pair wire (D1, D2)

*3-pair twisted cabling

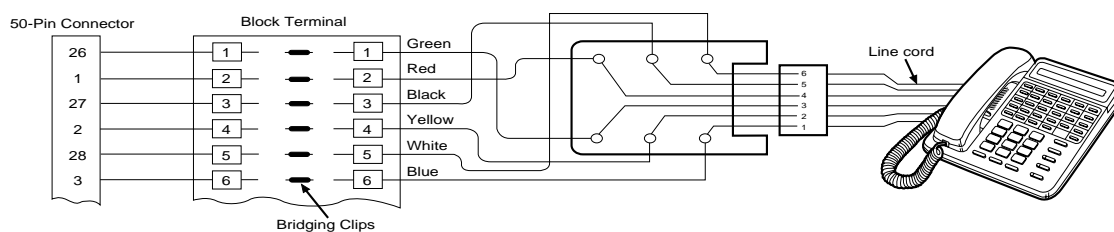

Connection

1. Insert the 50-pin connector to the Extension Jack as shown.
2. Connect the wire cords to the appropriate connector pins and the terminal equipment. Refer to the Telephone Wiring (Page 45) and Pin Number Chart (Page 49).

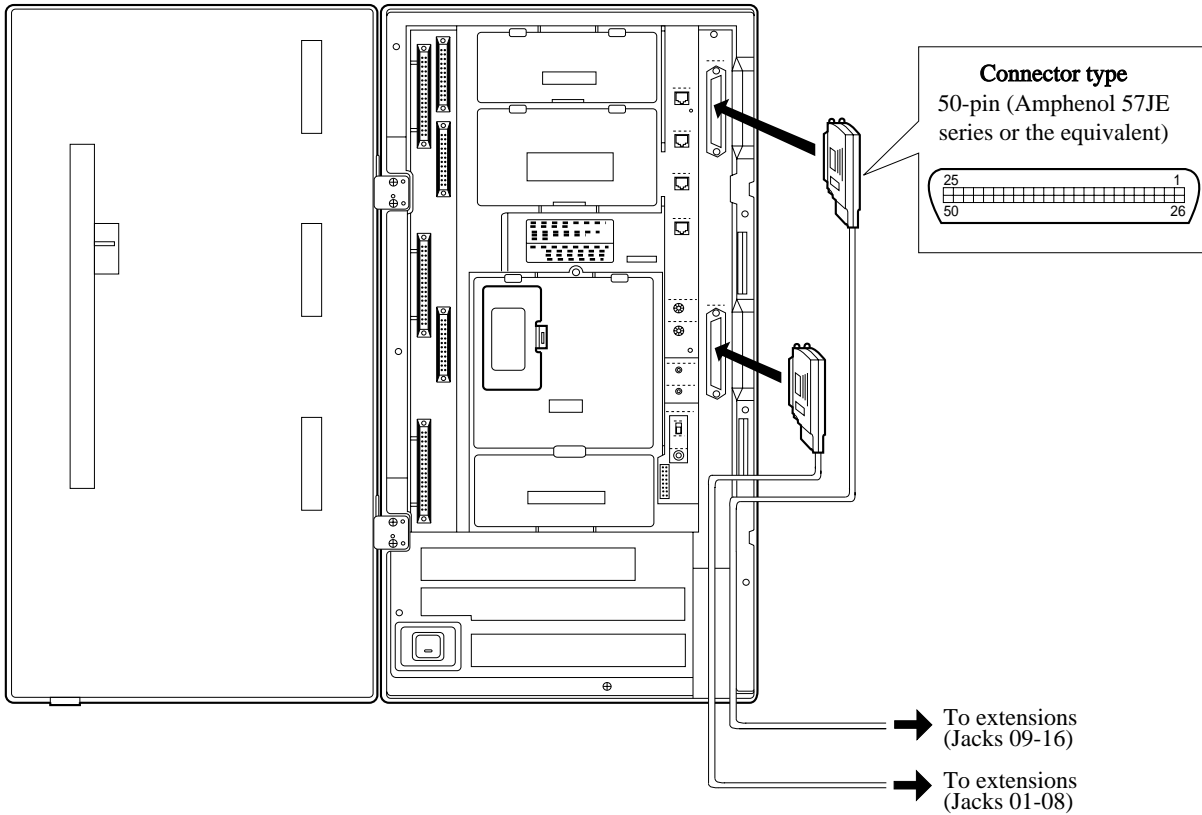

3. After inserting the connector, fasten the connector with the nylon tie.

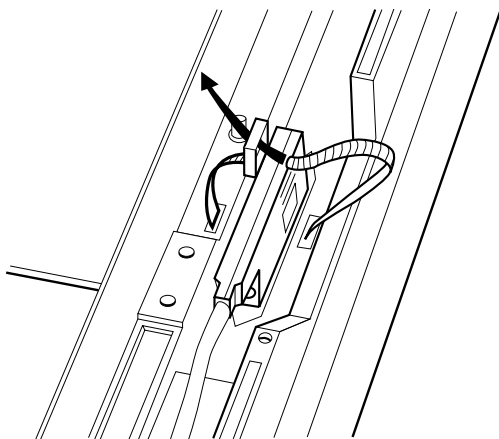

Pin Number Chart

Pin no.	EXTN. 01-08		EXTN. 09-16		8EXTN.		8EXTN.	
26		T		T		T		T
1		R		R		R		R
27	Jack	D1	Jack	D1	Jack	D1	Jack	D1
2	No.01	D2	No.09	D2	No.17	D2	No.25	D2
28		P1		P1		P1		P1
3		P2		P2		P2		P2
29		T		T		T		T
4		R		R		R		R
30	Jack	D1	Jack	D1	Jack	D1	Jack	D1
5	No.02	D2	No.10	D2	No.18	D2	No.26	D2
31		P1		P1		P1		P1
6		P2		P2		P2		P2
32		T		T		T		T
7		R		R		R		R
33	Jack	D1	Jack	D1	Jack	D1	Jack	D1
8	No.03	D2	No.11	D2	No.19	D2	No.27	D2
34		P1		P1		P1		P1
9		P2		P2		P2		P2
35		T		T		T		T
10		R		R		R		R
36	Jack	D1	Jack	D1	Jack	D1	Jack	D1
11	No.04	D2	No.12	D2	No.20	D2	No.28	D2
37		P1		P1		P1		P1
12		P2		P2		P2		P2
38		T		T		T		T
13		R		R		R		R
39	Jack	D1	Jack	D1	Jack	D1	Jack	D1
14	No.05	D2	No.13	D2	No.21	D2	No.29	D2
40		P1		P1		P1		P1
15		P2		P2		P2		P2

Pin no.	EXTN. 01-08		EXTN. 09-16		8EXTN.		8EXTN.	
41		T		T		T		T
16		R		R		R		R
42	Jack	D1	Jack	D1	Jack	D1	Jack	D1
17	No.06	D2	No.14	D2	No.22	D2	No.30	D2
43		P1		P1		P1		P1
18		P2		P2		P2		P2
44		T		T		T		T
19		R		R		R		R
45	Jack	D1	Jack	D1	Jack	D1	Jack	D1
20	No.07	D2	No.15	D2	No.23	D2	No.31	D2
46		P1		P1		P1		P1
21		P2		P2		P2		P2
47		T		T		T		T
22		R		R		R		R
48	Jack	D1	Jack	D1	Jack	D1	Jack	D1
23	No.08	D2	No.16	D2	No.24	D2	No.32	D2
49		P1		P1		P1		P1
24		P2		P2		P2		P2
50								
25								

Note

- "8EXTN" in the table indicates an extension expansion area for 8-Station Line Unit (KX-TD170). System Programming is required for card location identification. <SYS PRG [109]>
- If a telephone or answering machine with an A-A1 relay is connected to the main unit, set the A-A1 relay switch of the telephone or answering machine to OFF position.
- Mis-connection may cause the system to operate improperly. See 6.1.1 Installation and 6.1.2 Connection.
- Up to four consoles (e.g. KX-T7540) can be installed per system. As the console itself cannot work alone, it always requires a proprietary telephone used in pair. Place the console and the paired telephone side by side on your desk.
- It is necessary to designate the jack numbers of paired consoles and proprietary telephones by System Programming. <SYS PRG [007]>

- After completing all the required inside cabling, including outside lines, extensions, external pagers and external music sources, fasten the cables with the nylon tie (included) as shown.

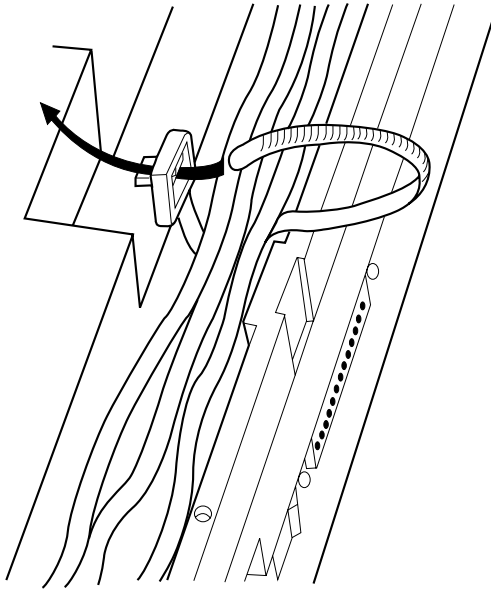

Programming Guide References

[007] Console Port and Paired Telephone Assignment

[109] Expansion Unit Type

Features Guide References

Console

2.3.3 Paralleled Telephone Connection

Any single line telephone can be connected in parallel with a proprietary telephone as follows:

Method 1: Using a Modular T-Adaptor

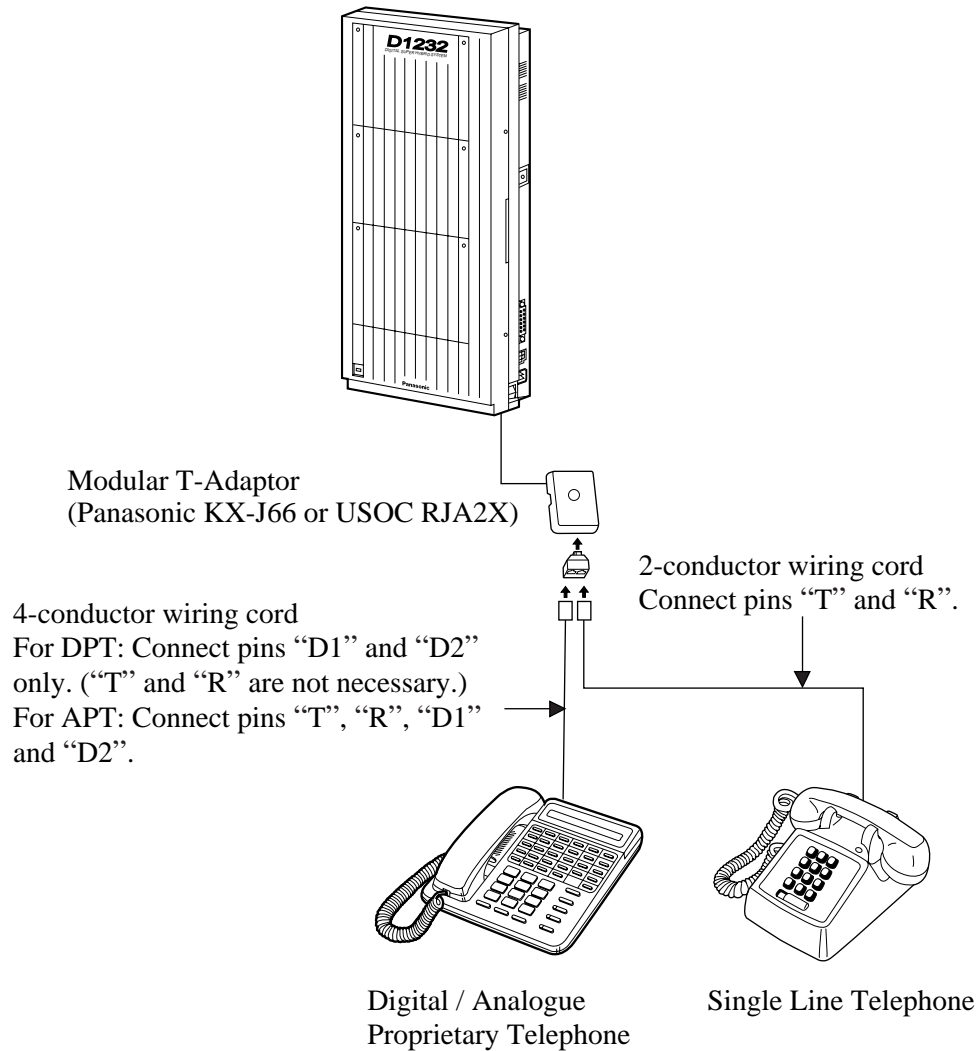

Note

- The KX-TD1232 is illustrated as the main unit.
- The 6-conductor wiring cord (and the Modular T-Adaptor KX-J36) is required if the proprietary telephone KX-T7130 is to be used for parallel connection for KX-TD1232.

Method 2: For Digital Proprietary Telephones only

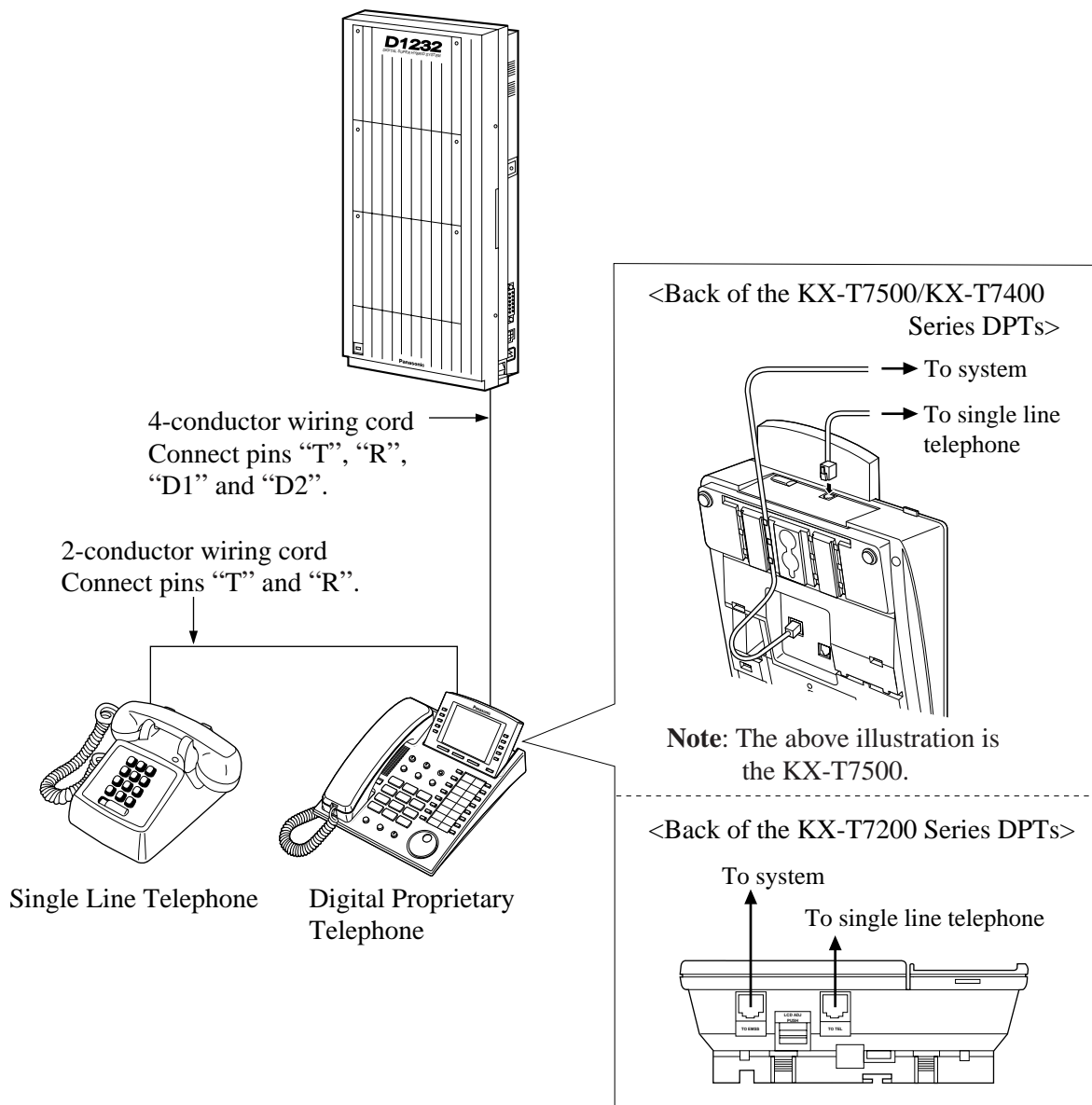

Note

- The KX-TD1232 is illustrated as the main unit.
- Not only a single line telephone but a single line device such as an answering machine, a facsimile or a modem (personal computer) etc. can be connected in parallel with a proprietary telephone.

Features Guide References

Paralleled Telephone

2.3.4 EXtra Device Port (XDP) Connection

A digital proprietary telephone and a single Line telephone can be connected to the same extension jack yet have different extension numbers (eXtra Device Port feature). System Programming is required for this jack.

Method 1

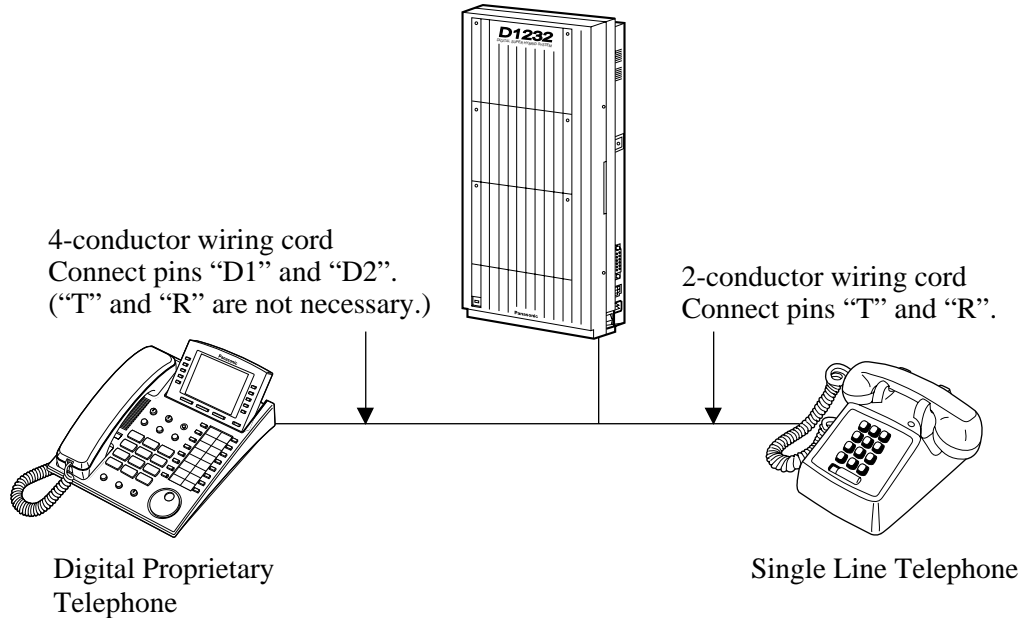

Note

- The KX-TD1232 is illustrated as the main unit.

Method 2

Section 2.3.3 Paralleled Telephone Connection, Method 2: for Digital Proprietary Telephone only is also available for XDP connection.

Programming Guide References

[600] EXtra Device Port

Features Guide References

EXtra Device Port (XDP)

2.3.5 Polarity Sensitive Telephone Connection

If your telephone is polarity sensitive, follow the procedure below:

1. Complete all the required extension wiring.
2. Confirm that dialling can be done from all the extensions using a touch-tone telephone. If dialling fails, the polarity between the extension and the system must be reversed.
3. Reverse as shown.

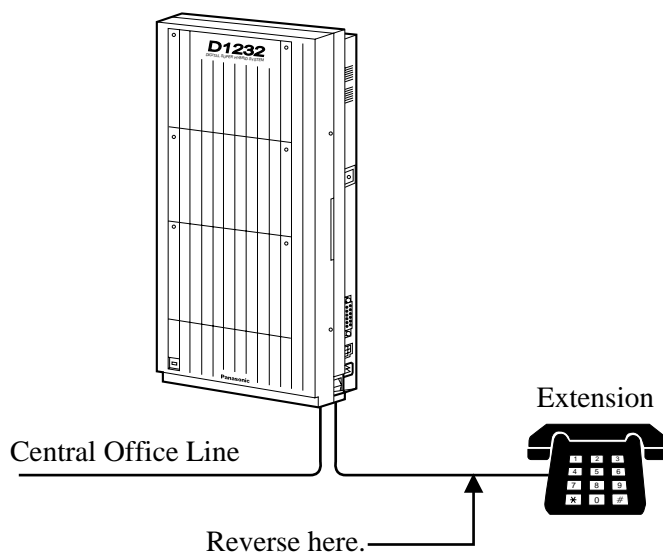

4. Set the Power Switch to "OFF" position.
5. Connect all outside lines.
6. Confirm that dialling can be done on the following extensions using a tone telephone.

KX-TD816

Extension (T, R) of jack 01: Outside line 01

Extension (T, R) of jack 02: Outside line 02

Extension (T, R) of jack 09 and 10 (Extension Expansion Card): Outside line 5 and 6

KX-TD1232

Extension (T, R) of jack 01: Outside line 01

Extension (T, R) of jack 02: Outside line 02

Extension (T, R) of jack 09: Outside line 03

Extension (T, R) of jack 10: Outside line 04

Extensions (T, R) of jacks 17 and 18 (Extension Expansion Card 1): Outside line 09 and 10

(**Note:** Extensions of jacks 09 and 10 for KX-TD816, and 17 and 18 for KX-TD1232 depend on the Power Failure Transfer connection. For details, refer to Section 2.5.1 Auxiliary Connection for Power Failure Transfer.)

If dialling fails, the polarity between the system and the outside line must be reversed.

7. Reverse as shown.

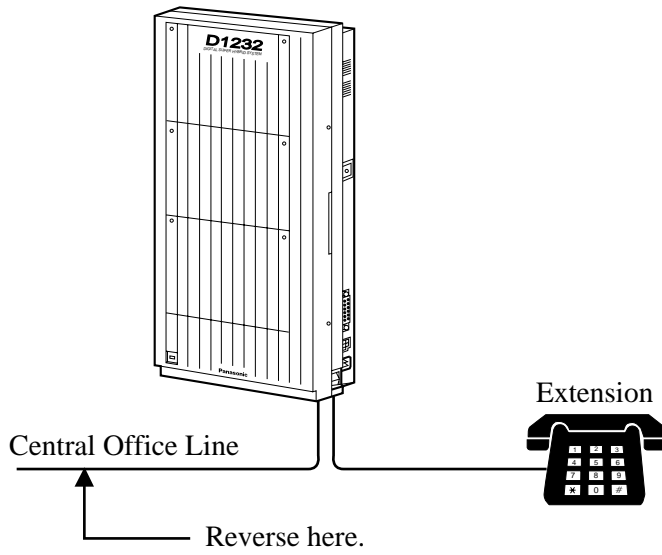

8. Every time an extension telephone is replaced, repeat the above procedure.

Note

The KX-TD1232 is illustrated as the main unit.

2.3.6 External Pager (Paging Equipment) Connection

KX-TD816

One external pager (user-supplied) can be connected to the KX-TD816 as illustrated below. Use an RCA connector and shielded cable.

- Output impedance: 600 Ω
Maximum length of the cable
AWG 18 – 22: Under 10 m

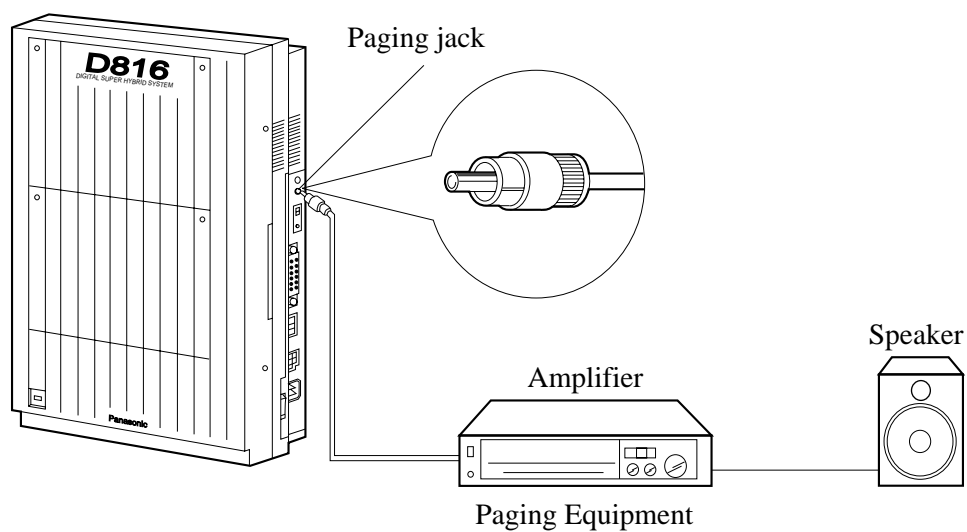

KX-TD1232

Up to two external pagers (user-supplied) can be connected to the KX-TD1232 per system as illustrated below.

Use an RCA connector and shielded cable.

- Output impedance: 600 Ω
Maximum length of the cable
 AWG 18 – 22: Under 10 m

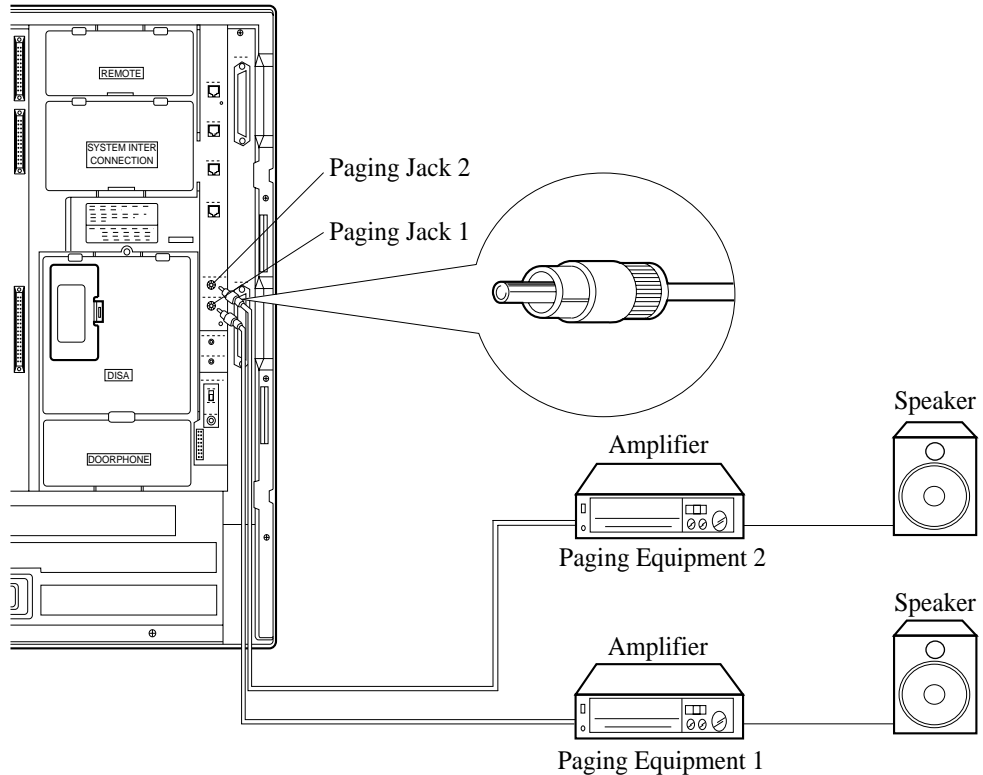

Note

- System Connection^{*1} permits a maximum of four external pagers. It is programmable which external pager will send background music and whether all the pagers will generate a confirmation tone.
- To adjust the sound level of the pagers, use the volume control on the amplifiers.

Programming Guide References

- [804] External Pager BGM
- [805] External Pager Confirmation Tone

^{*1} Available for the KX-TD1232 only.

Features Guide References

Background Music (BGM)

Paging

Trunk (Outside Line) Answer From Any Station (TAFAS)

2.3.7 External Music Source Connection

KX-TD816

One music source such as a radio (user-supplied) can be connected to the KX-TD816 as illustrated below.

Insert the plug to the earphone / headphone jack on the external music source. Use a two-conductor plug (3.5 mm in diameter).

- Input impedance: 8 Ω
Maximum length of the cable
AWG 18 – 22: Under 10 m

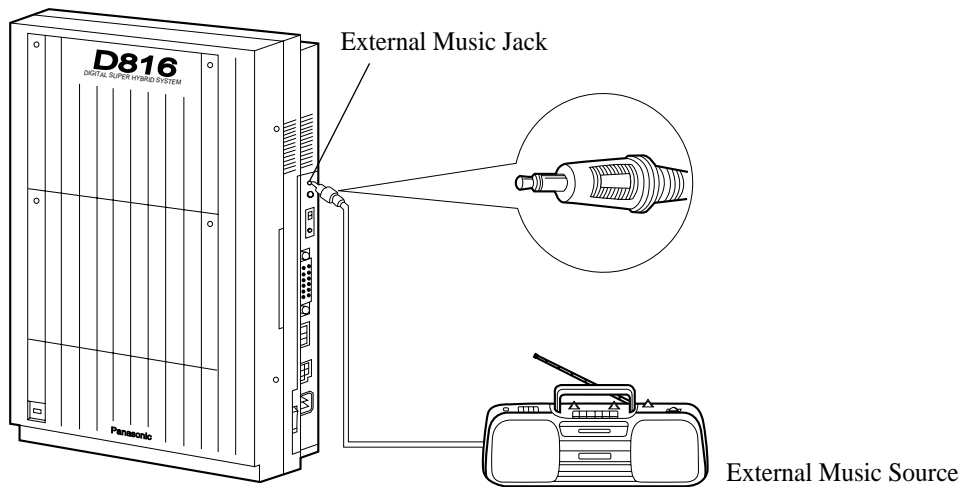

KX-TD1232

Up to two music sources such as a radio (user-supplied) can be connected to the KX-TD1232 per system as illustrated below.

Insert the plug to the earphone / headphone jack on the external music source.

Use a two-conductor plug (3.5 mm in diameter).

- Input impedance: 8 Ω

Maximum length of the cable

AWG 18 – 22: Under 10 m

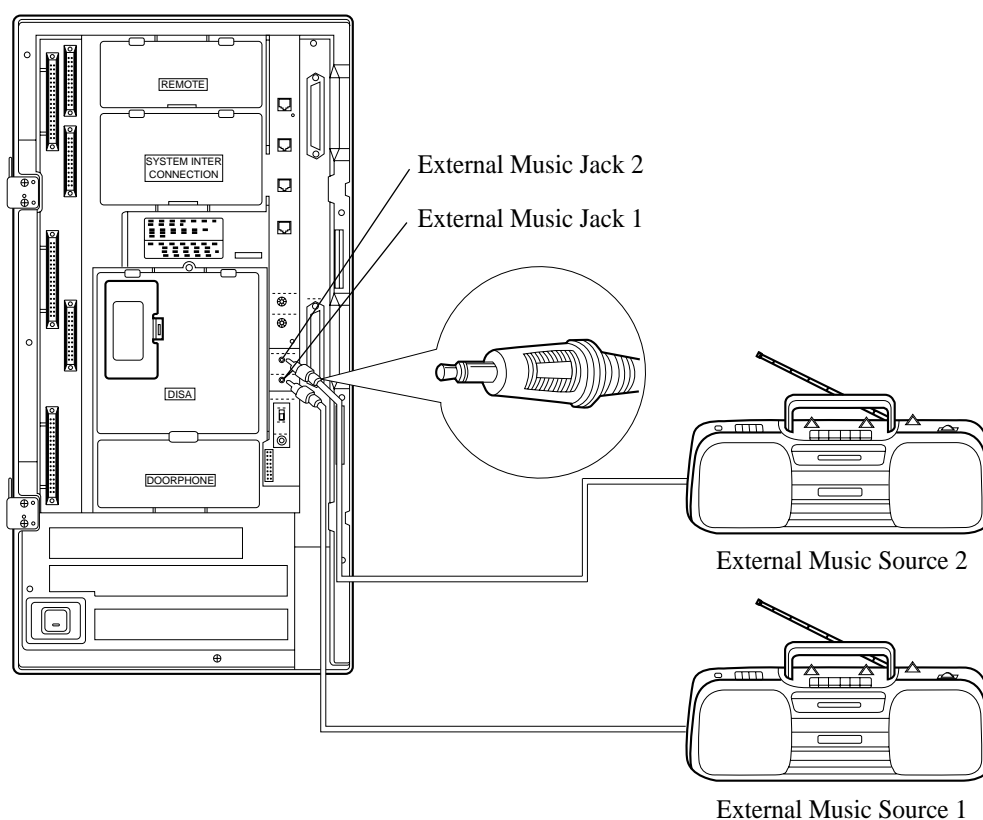

Note

- By default setting, Music Source 1 is used for Music on Hold and Background Music (BGM). <SYS PRG [803]>
- The system is provided with an internal music source. By default setting, an internal music source is used as Music Source 1. System Programming is required to use an external music source or tone as Music Source 1. <SYS PRG [990], Area 06-Bits 11 and 10>
- To adjust the sound level of the Music on Hold, use the volume control on the external music source.

Programming Guide References

[803] Music Source Use

[990] System Additional Information

Features Guide References

Background Music (BGM)

2.3.8 Printer and PC Connection

A user-supplied printer or personal computer (PC) can be connected to the system. These are used to print out or refer to the Station Message Detail Recording (SMDR) call records and system programming data.

Connect the printer cable or the PC cable to the Serial Interface (RS-232C) connector. The cable must be shielded and the maximum length is 2 m.

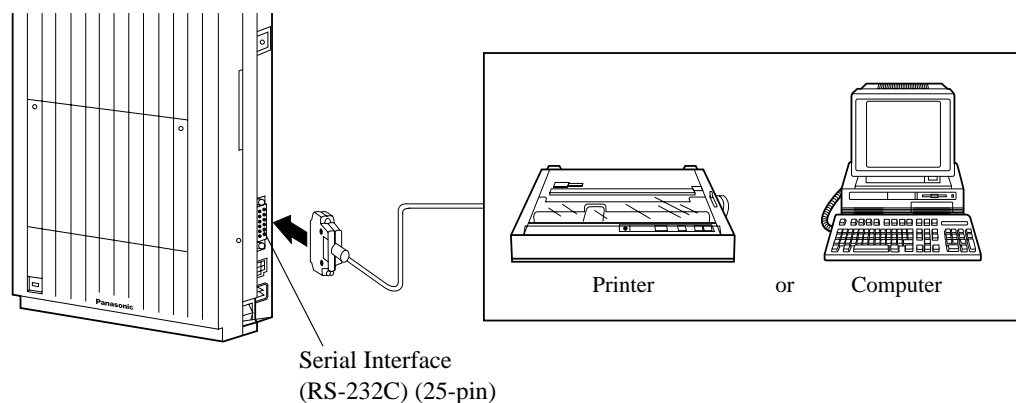

Note

The KX-TD1232 is illustrated as the main unit.

Arrange cables so that the printer will be connected to the system as shown in the chart on the following page.

The pin configuration of Serial Interface (RS-232C) Connector is as follows:

Pin No.	Signal Name		Circuit Type	
			EIA	CCITT
1	FG	Frame Ground	AA	101
2	SD (TXD)	Transmitted Data	BA	103
3	RD (RXD)	Received Data	BB	104
4	RS (RTS)	Request To Send	CA	105
5	CS (CTS)	Clear To Send	CB	106
6	DR (DSR)	Data Set Ready	CC	107
7	SG	Signal Ground	AB	102
8	CD (DCD)	Data Carrier Detect	CF	109
20	ER (DTR)	Data Terminal Ready	CD	108.2

Connection Chart for Printer / IBM^{*1} Personal Computer

If you connect a printer or a PC with a 25-pin cable, follow the chart below.

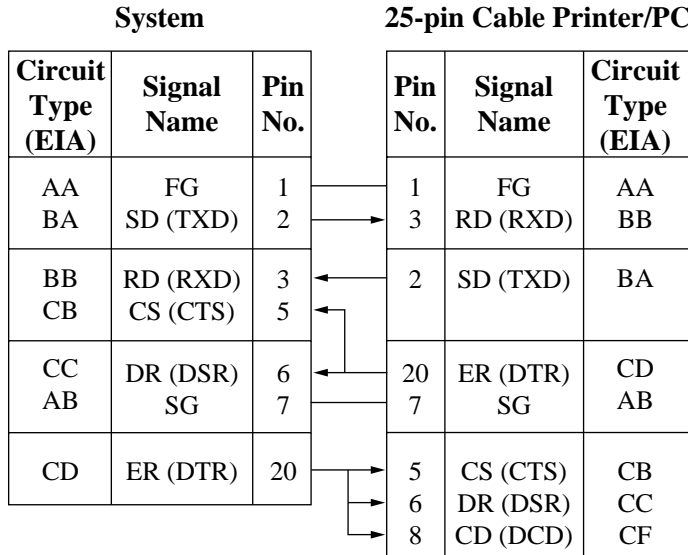

If you connect a printer or an IBM-PC with a 9-pin cable, follow the chart below.

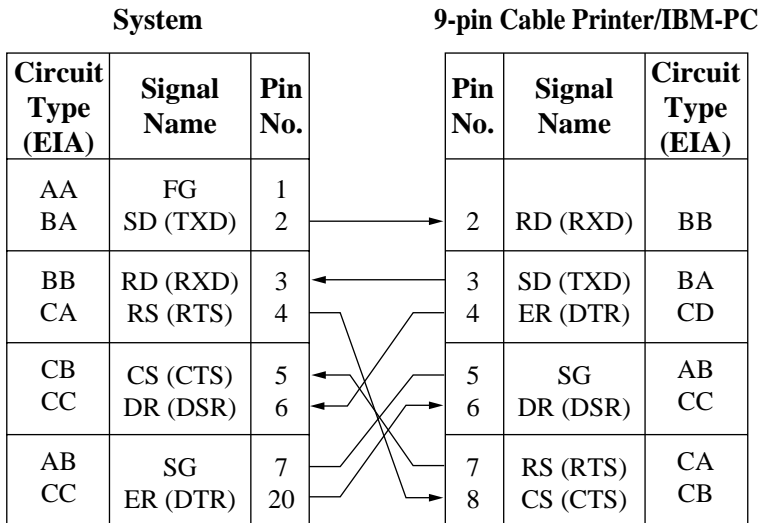

Note

Please read your printer manual and connect the first EIA pin (FG) of this unit to the printer cable.

*1 IBM is registered trademark of International Business Machines Corporation.

Serial Interface (RS-232C) Signals

Frame Ground: FG

Connects to the unit frame and the earth ground conductor of the AC power cord.

Transmitted Data: SD (TXD): (output)

Conveys signals from the unit to the printer. A "Mark" condition is held unless data or BREAK signals are being transmitted.

Received Data: RD (RXD): (input)

Conveys signals from the printer.

Request to Send: RS (RTS): (output)

This lead is held ON whenever DR (DSR) is ON.

Clear To Send: CS (CTS): (input)

An ON condition of circuit CS (CTS) indicates that the printer is ready to receive data from the unit. The unit does not attempt to transfer data or receive data when circuit CS (CTS) is OFF.

Data Set Ready: DR (DSR): (input)

An ON condition of circuit DR (DSR) indicates the printer is ready. Circuit DR (DSR) ON does not indicate that communication has been established with the printer.

Signal Ground: SG

Connects to the DC ground of the unit for all interface signal.

Data Terminal Ready: ER (DTR): (output)

This signal line is turned ON by the unit to indicate that it is ON LINE. Circuit ER (DTR) ON does not indicate that communication has been established with the printer. It is switched OFF when the unit is OFF LINE.

Data Carrier Detect: CD (DCD): (input)

The ON condition is an indication to data terminal (DTE) that the carrier signal is being received.

Programming Guide References

- [800] SMDR Incoming / Outgoing Call Log Printout
- [801] SMDR Format
- [802] System Data Printout
- [806-807] Serial Interface (RS-232C) Parameters
- [990] System Additional Information

Features Guide References

- Hotel Application
- Station Message Detail Recording (SMDR)
- System Programming and Diagnosis with Personal Computer

2.3.9 Installation of Lightning Protectors

Overview

A lightning protector is a device to be installed on an outside line to prevent a dangerous surge from entering the building and damaging equipment.

A dangerous surge can occur if a telephone line comes in contact with a power line. Trouble due to lightning surges has been showing a steady increase with the development of electronic equipment.

In many countries, there are regulations requiring the installation of a lightning protector. A lightning strike to a telephone cable which is 10 m above ground can be as high as 200,000 V.

This system should be installed with lightning protectors. In addition, grounding (connection to earth ground) is very important for the protection of the system.

Installation Diagram

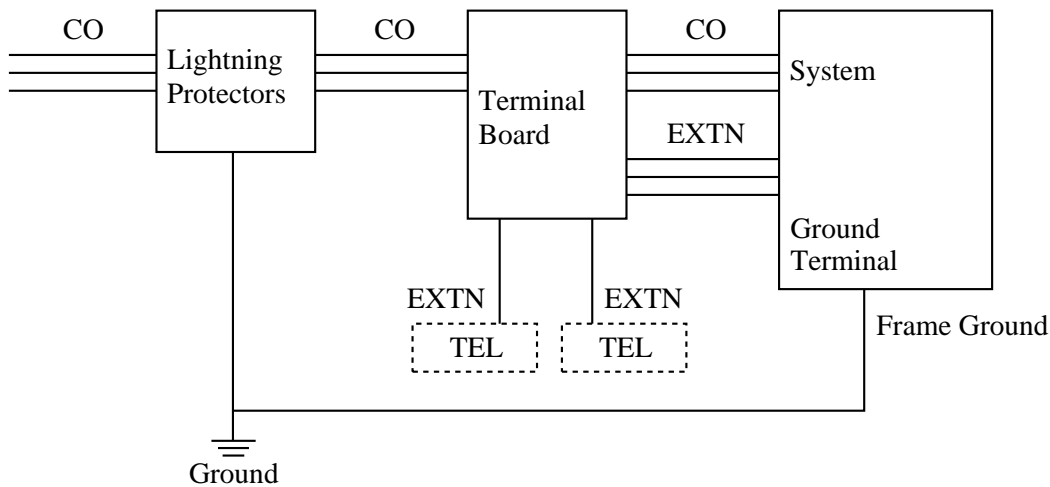

CO: Central Office (Outside line)

EXTN: Extension line

TEL: Telephone

Outside Installation Diagram

If you install an extension outside of the main building, the following precautions are recommended:

- a) Install the extension wire underground.
- b) Use a conduit to protect the wire.

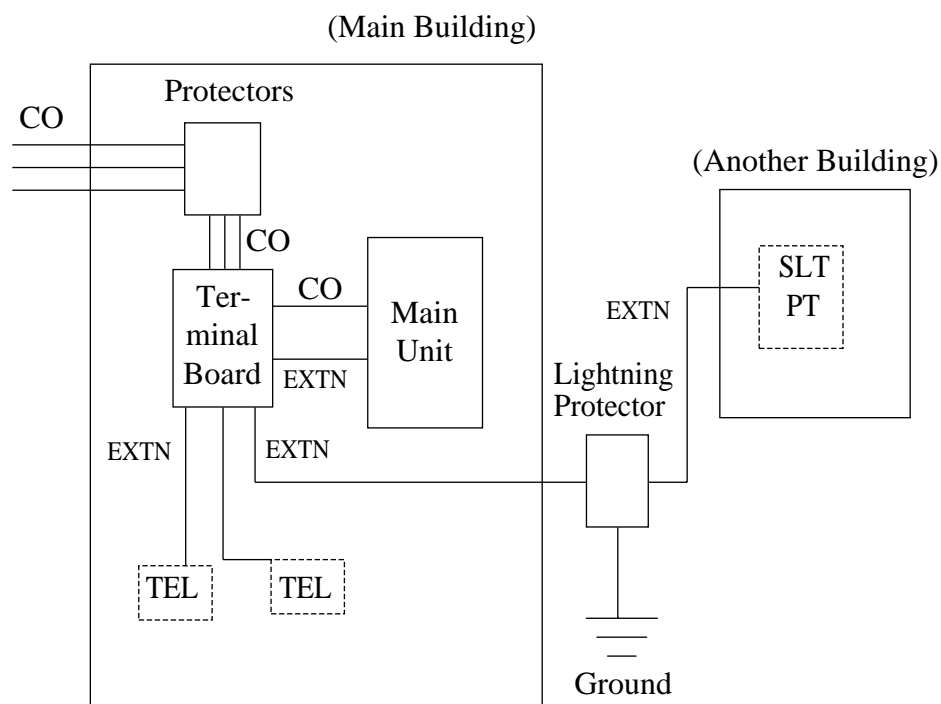

Note

The lightning protector for an extension is different from that for outside line.

Earth Rod Installation Diagram

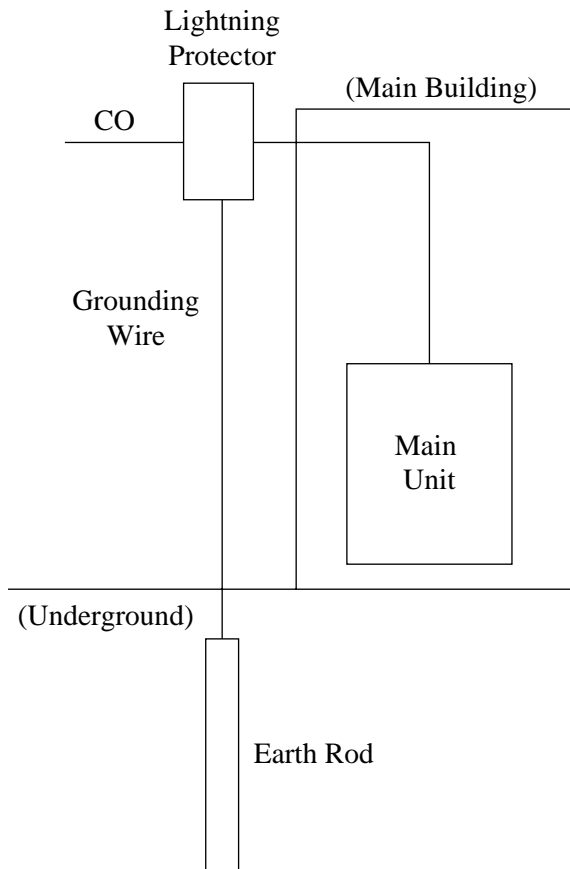

1. Installation location of the earth rod: Near the protector
2. Check obstructions: None
3. Composition of the earth rod: Metal
4. Depth of the earth rod: More than 50 cm
5. Size of the grounding wire: Thickness is more than 16 AWG

Note

- The above figures are recommendations only.
- The length of earth rod and the required depth depend on the composition of the soil.

2.4 Installation of Optional Cards and Unit

2.4.1 Location of Optional Cards and Units

The location of the optional cards and units is shown below.

Precaution

To protect the printed circuit boards (P-boards) from static electricity, do not touch parts on the P-boards in the main unit and on the optional cards.

Expansion Units

KX-TD816

The following expansion units can be installed to any of the two expansion areas.

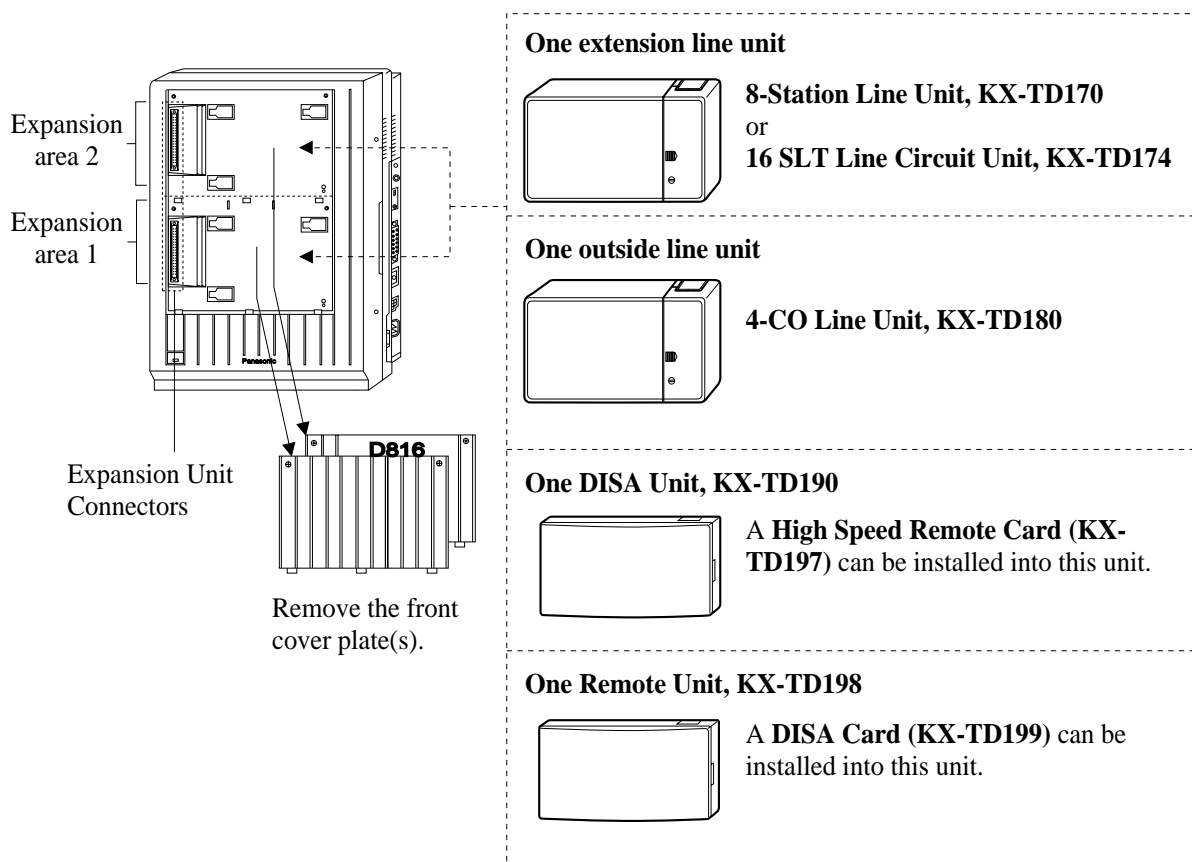

Note

- System Programming is required for expansion unit location. <SYS PRG [109]>
Default:
 Area 1 = 4-CO Line Unit,
 Area 2 = 8-Station Line Unit.
- It is also possible to attach the line expansion unit to the DISA or Remote Unit and install them to the main unit.
- For unit combinations, refer to Section 1.4.2 Expansion Unit Combination.

KX-TD1232

The following expansion units can be installed to any of the three expansion areas.

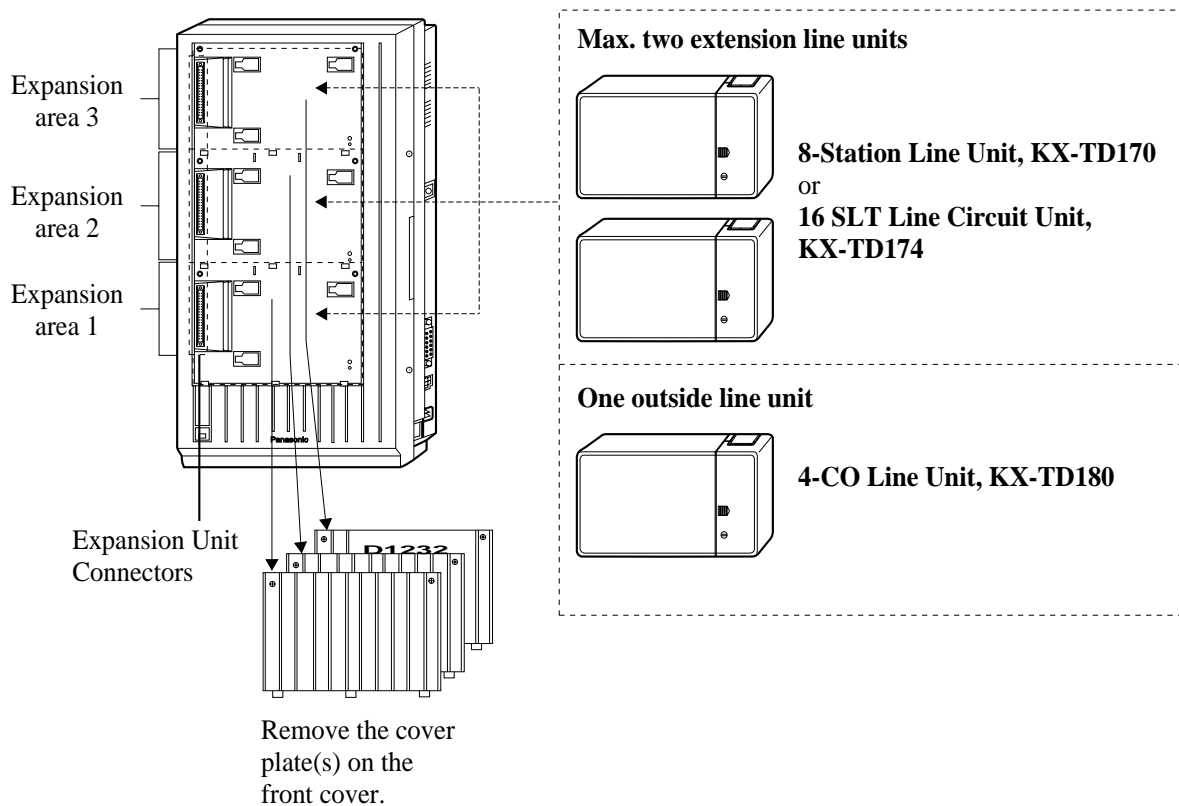

Note

- System Programming is required for expansion unit location. <SYS PRG [109]>
Default:
 Area 1 = 4-CO Line Unit,
 Area 2 and 3 = 8-Station Line Unit.
- It is also possible to attach the line expansion unit to the DISA or Remote Unit and install them to the main unit.
- For unit combinations, refer to Section 1.4.2 Expansion Unit Combination.

Doorphone Card for KX-TD816

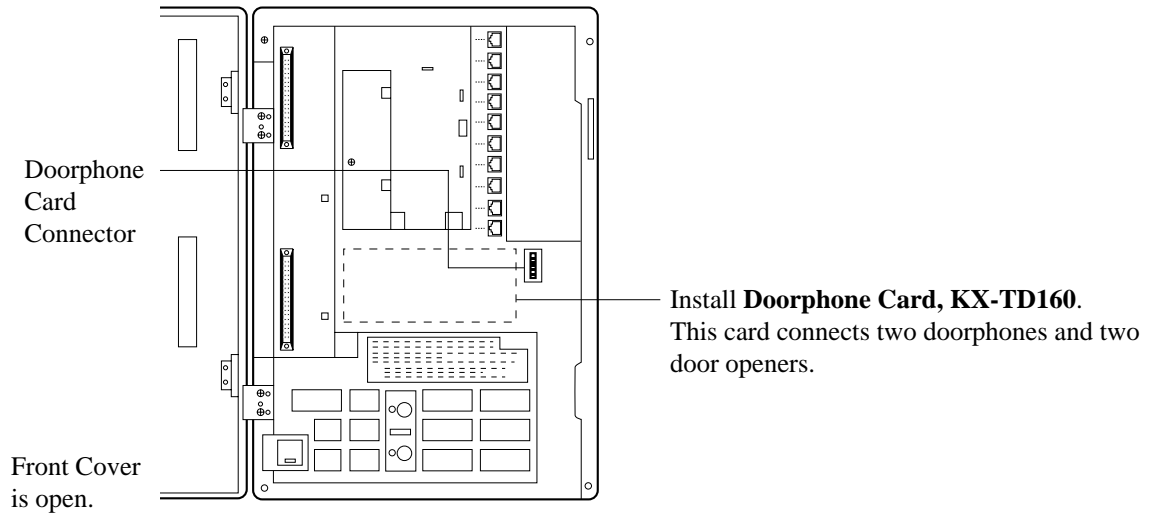

Pay Tone Card for KX-TD816

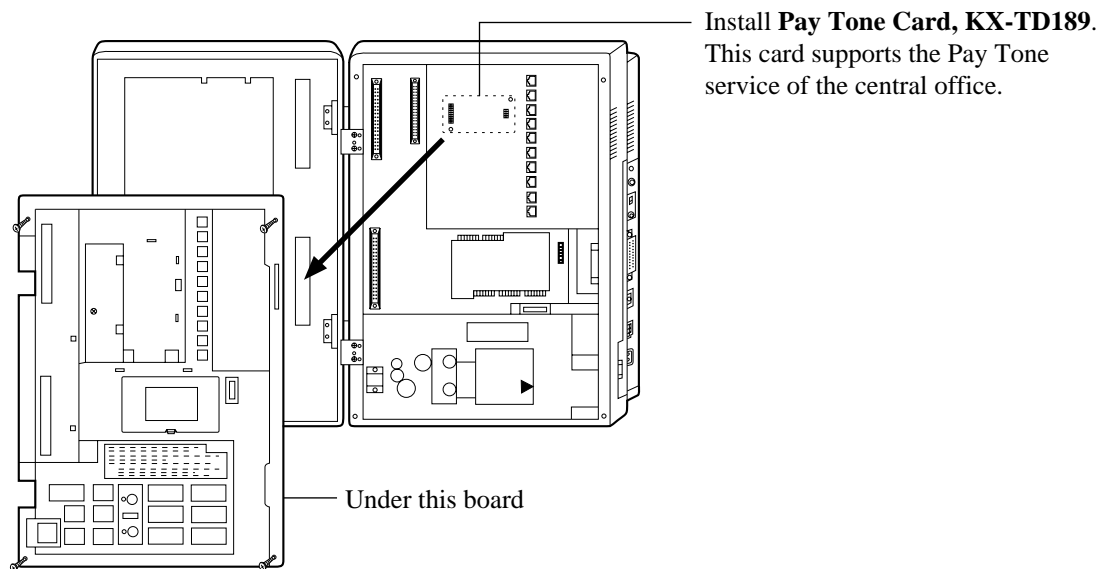

Remote Card, System Inter Connection Card, DISA Card, Doorphone Card for KX-TD1232

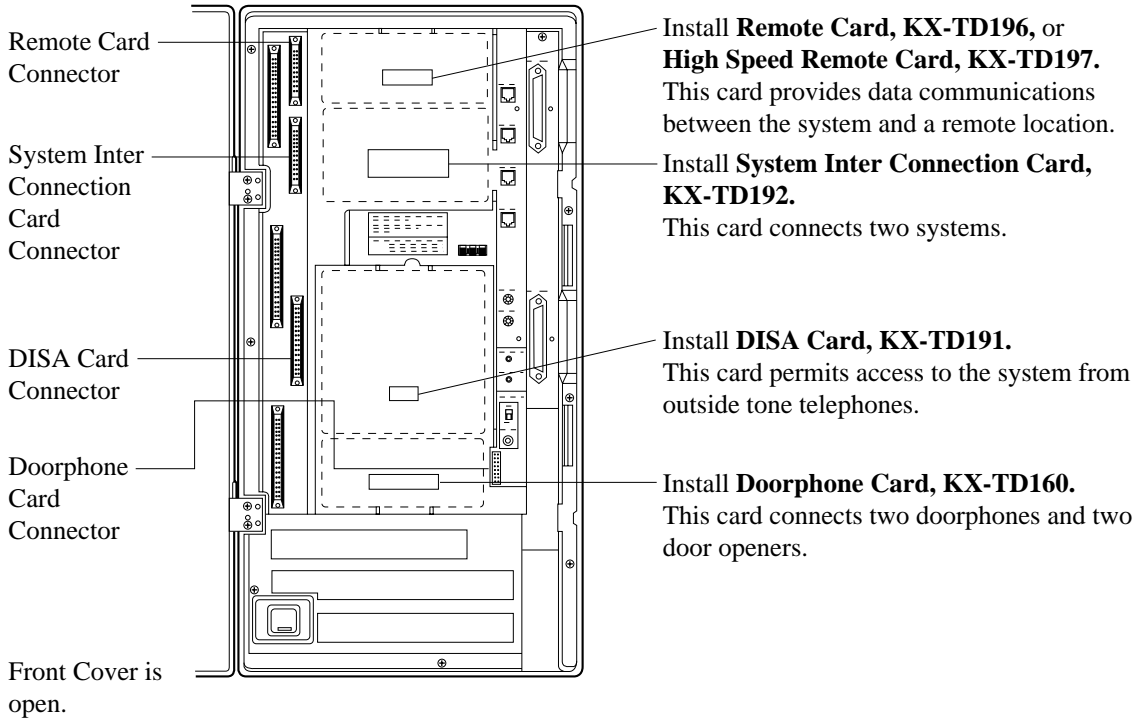

Pay Tone Card for KX-TD1232

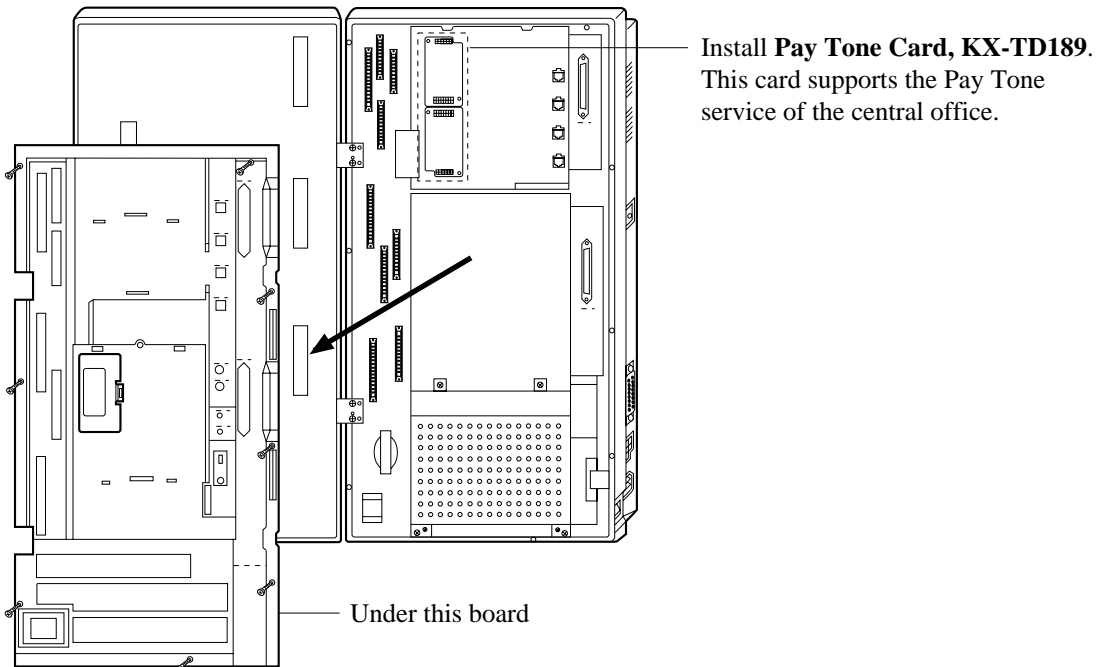

SLT Message Waiting Lamp Adaptor Unit

One SLT Message Waiting Lamp Adaptor Unit (KX-TD194) for KX-TD816, and up to three SLT Message Waiting Lamp Adaptor Units for KX-TD1232 can be installed. This card supports the Message Waiting feature for a single line telephone with a message waiting lamp. One adaptor supports 16 extensions.

Connection Example

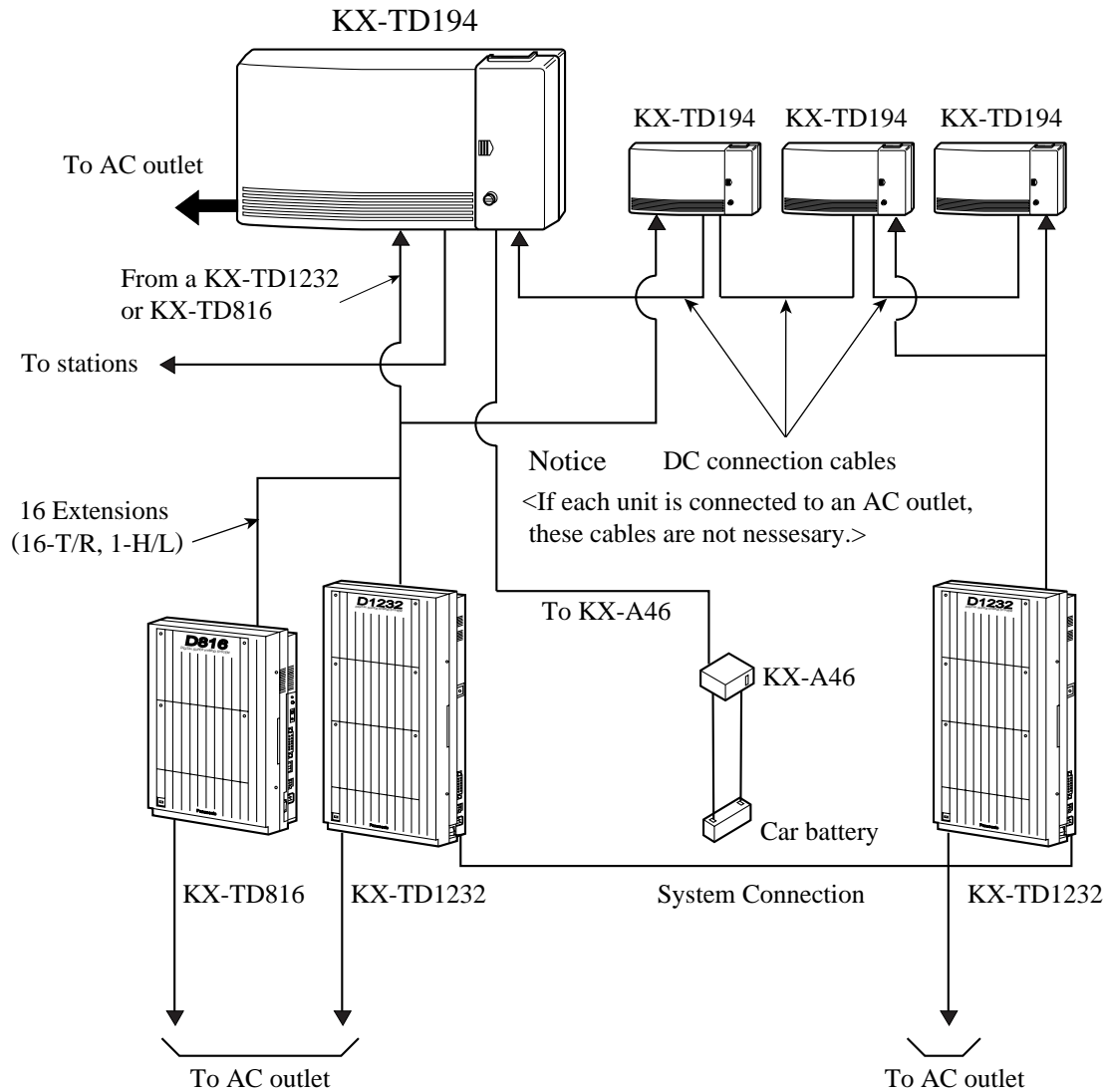

Note

Do not connect more than four units with DC connection cables.

2.4.2 4-CO Line Unit Connection

To add four outside lines (outside lines 05 through 08 for KX-TD816, and outside lines 09 through 12 for KX-TD1232), use the optional 4-CO Line Unit (KX-TD180).

This unit can be installed to any of the expansion unit areas provided on the front of the main unit. For outside line expansion unit installation, see Section 2.4.5 Installing Expansion Unit. System Programming is required for card location identification.

Programming Guide References

[109] Expansion Unit Type

2.4.3 8-Station Line Unit Connection

To add eight extensions (jack numbers 09 through 16 for KX-TD816, and jack numbers 17 through 24 or 25 through 32 for KX-TD1232), use the optional 8-Station Line Unit (KX-TD170). To add 16 extensions for KX-TD1232 (jack numbers 17 through 32), use two 8-Station Line Units.

This unit can be installed to any of the expansion unit areas provided on the front of the main unit. For extension expansion unit installation, see Section 2.4.5 Installing Expansion Unit. System Programming is required for card location identification.

This unit can be installed to any of the expansion unit areas provided on the front of the main unit. For extension expansion unit installation, see Section 2.4.5 Installing Expansion Unit. System Programming is required for card location identification.

Programming Guide References

[109] Expansion Unit Type

2.4.4 16 SLT Line Circuit Unit

To add eight extensions which contain two single line telephones, use the optional 16 SLT Line Circuit Unit (KX-TD174). The unit can support 16 single line telephones per unit. Each single line telephone in the same jack has different extension number so that it can act as completely different extension like an eXtra Device Port feature.

Note

- Installing this unit allows the eXtra Device Port setting to "Enable" automatically in system programming [600]. However, assigning "Disable" makes a single line telephone which is connected to the second jack (Jack xx-2) disable to use.
- This unit cannot support the proprietary telephone and Voice Mail Integration features.
- This unit has four DTMF receivers; two receivers in the first eight ports and two receivers in the last eight ports.
- The Ringing Patterns for all single line telephones which are connected to the system are changed as below;

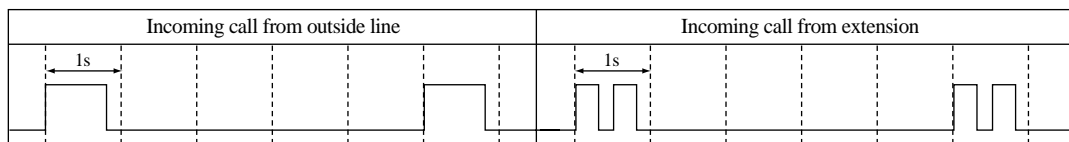

Auxiliary Connection for Power Failure Transfer

When there is a power failure, the first two jacks on this unit can be connected to specific CO lines mentioned below. An auxiliary connection is required to implement this feature. For more information about the connection between an extension jack to a CO line, refer to Section 2.5 Auxiliary Connection for Power Failure Transfer.

Programming Guide References

- [109] Expansion Unit Type
- [600] EXtra Device Port

2.4.5 Installing Expansion Unit

The following procedures can be used to install the optional expansion units.

The following steps 1 through 5 and 7 through 10 are the same for all expansion units. Step 6 is different for each unit.

The KX-TD1232 is illustrated as the main unit.

1. Loosen the two screws on the cover plate. Insert fingers into the slits to remove the cover plate.

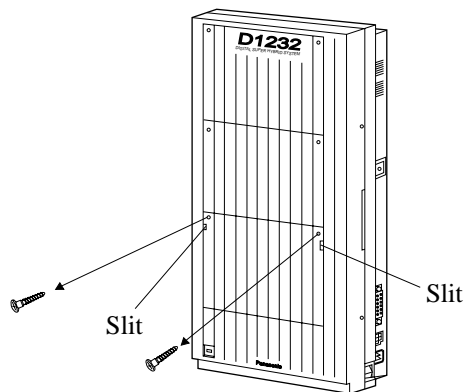

Note

Any of the cover plates can be removed, as needed.

2. Connect the cabinet cord to the connector in the main unit firmly.

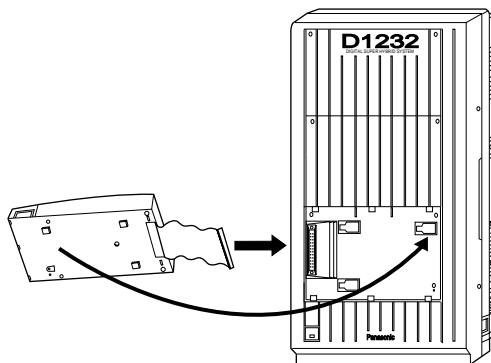

3. Hook the cabinet on the main unit and slide the cabinet to the left until it is secured.

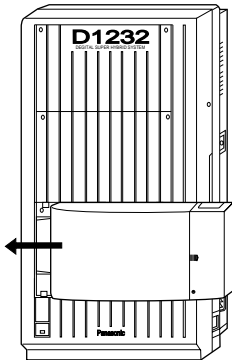

4. Loosen the outside screw and slide the cover to the right.

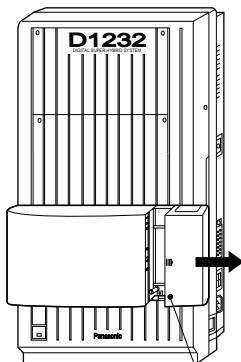

Outside screw

5. Secure the inside screw (included) to fix the cabinet to the main unit.

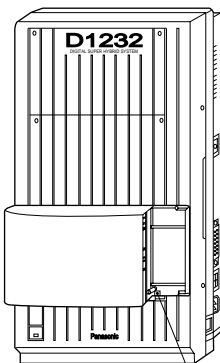

Inside screw

Note

Be sure to fix the inside screw to the main unit, or the unit may not work properly.

6. (If a option is to be installed)

If a KX-TD180 is to be installed;

Insert the modular plugs of the telephone line cords (4-conductor wiring) into the modular jacks on the unit.

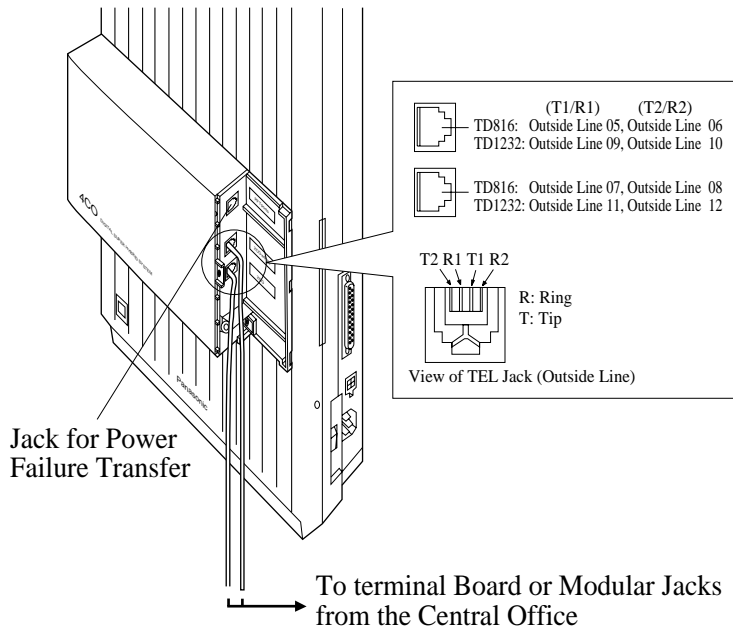

Note

- For details about the jack for Power Failure Transfer, refer to Section 2.5.1 Auxiliary Connection for Power Failure Transfer.

If a KX-TD170 and a KX-TD174 is to be installed;

Insert the connector into the jack.

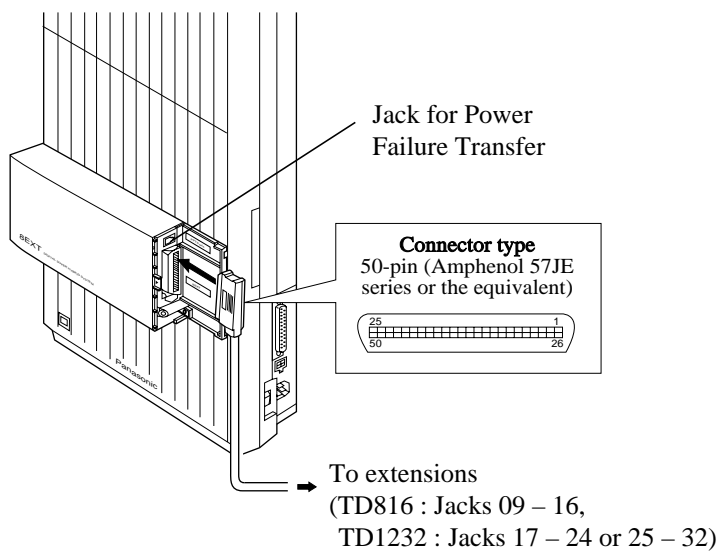

Note

- For details about the jack for Power Failure Transfer, refer to Section 2.5.1 Auxiliary Connection for Power Failure Transfer.
 - For cable pin numbers to be connected, see "Pin Number Chart" in Section 2.3.2 Extension Connection and "Pin Number Chart for the KX-TD174" on Page 83.
 - For fixing the connector, see "Amphenol 57JE Type (screw-attach-type 50-pin connector) Connection" on Page 81.
7. Tie all of the cords into a bundle. If other cords are exposed in the upper cabinets, tie them also.
 8. Close the cabinet cover and secure the outside screw.
 9. Cover the cords with the cord holder (included).

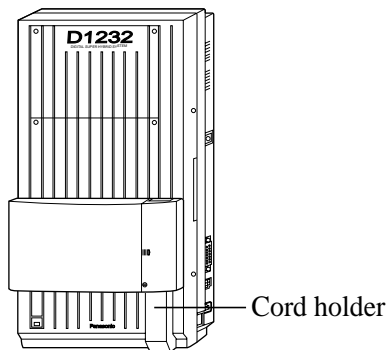

10. Fix the cords to the wall as shown so that the front cover can be opened.

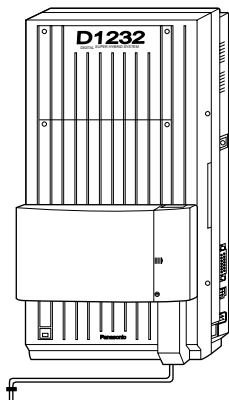

Note

If two expansion units are installed, cut the cabinet cover(s) on the lower cabinet(s) to allow the cords from upper cabinet to go down through the cabinet cover(s). To protect the cords, smooth the cut edges.

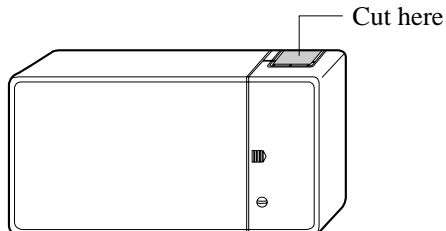
**Amphenol 57JE Type (screw-attach-type 50-pin connector) Connection**

To fix the Amphenol 57JE type (screw-attach type 50-pin connector) to the 8-Station Line Unit, follow the procedure below.

1. The 50-pin connector (Jack) on the Expansion Unit has two hook-pins. Remove the upper hook-pin, and take out the screw.

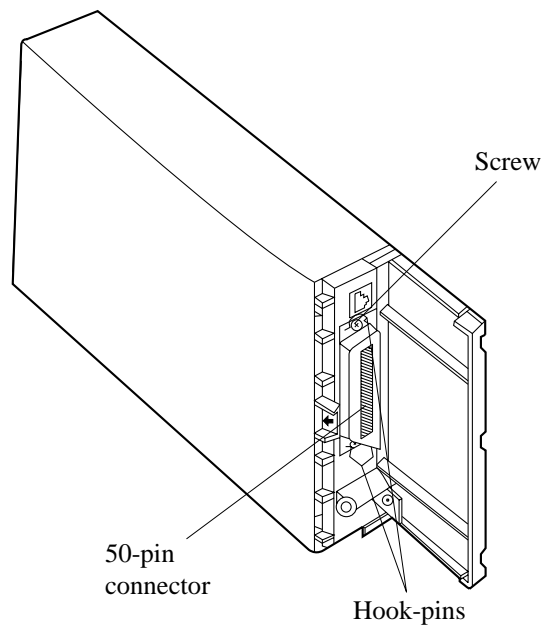

Note

When installing a connector like the type shown below, unscrew the lower hook-pin also. Then drive both accessory screws.

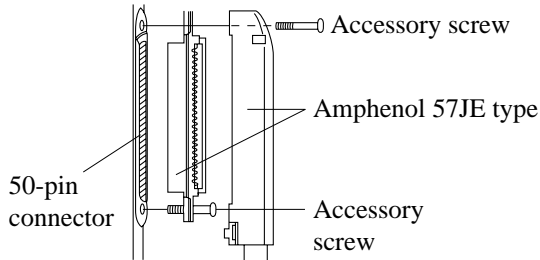

2. To attach the Amphenol 57JE type (Plug) to the connector, drive the accessory screw into the upper part.
Fasten the accessory wire tie around the lower hook-pin and the Amphenol 57JE type, as shown.

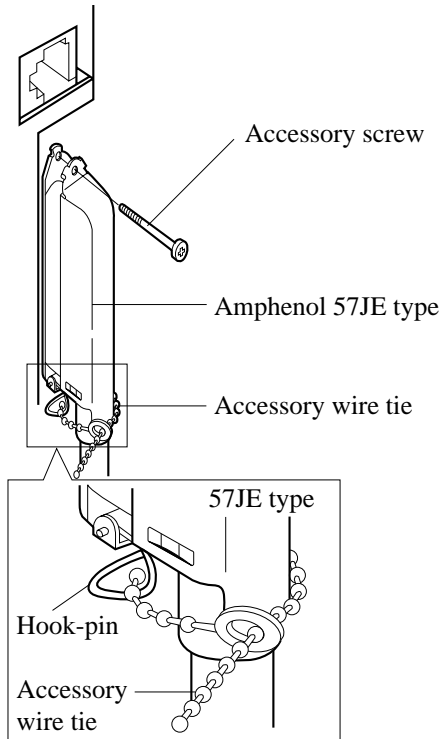

Pin Number Chart for the KX-TD174

CONN PIN	Clip Terminal (KX-A205) No.	For KX-TD816		For KX-TD1232 (Expansion 1)		For KX-TD1232 (Expansion 2)	
		Jack No.9-16		Jack No.17-24		Jack No.25-32	
26 1	1 2	Jack. 09-1	T R	Jack. 17-1	T R	Jack. 25-1	T R
27 2	3 4	Jack. 10-1	T R	Jack. 18-1	T R	Jack. 26-1	T R
28 3	5 6	Jack. 11-1	T R	Jack. 19-1	T R	Jack. 27-1	T R
29 4	7 8	Jack. 12-1	T R	Jack. 20-1	T R	Jack. 28-1	T R
30 5	9 10	Jack. 13-1	T R	Jack. 21-1	T R	Jack. 29-1	T R
31 6	11 12	Jack. 14-1	T R	Jack. 22-1	T R	Jack. 30-1	T R
32 7	13 14	Jack. 15-1	T R	Jack. 23-1	T R	Jack. 31-1	T R
33 8	15 16	Jack. 16-1	T R	Jack. 24-1	T R	Jack. 32-1	T R
34 9	17 18	Jack. 09-2	T R	Jack. 17-2	T R	Jack. 25-2	T R
35 10	19 20	Jack. 10-2	T R	Jack. 18-2	T R	Jack. 26-2	T R
36 11	21 22	Jack. 11-2	T R	Jack. 19-2	T R	Jack. 27-2	T R
37 12	23 24	Jack. 12-2	T R	Jack. 20-2	T R	Jack. 28-2	T R
38 13	25 26	Jack. 13-2	T R	Jack. 21-2	T R	Jack. 29-2	T R
39 14	27 28	Jack. 14-2	T R	Jack. 22-2	T R	Jack. 30-2	T R
40 15	29 30	Jack. 15-2	T R	Jack. 23-2	T R	Jack. 31-2	T R
41 16	31 32	Jack. 16-2	T R	Jack. 24-2	T R	Jack. 32-2	T R

2.4.6 Pay Tone Card Installation

Installing to the Initial CO Line Card

1. Loosen four screws for KX-TD816 or eight screws for KX-TD1232 to open the inside cover of the main unit.

Note

If any cards, units, or cords are installed in the main unit, remove them beforehand.

2. Attach the Pay Tone Card(s) (KX-TD189) to the CO Line Card, with the spacers (Accessory included).

One Pay Tone Card for KX-TD816, and up to two Pay Tone Cards for KX-TD1232 can be installed to the initial CO Line Card.

KX-TD816

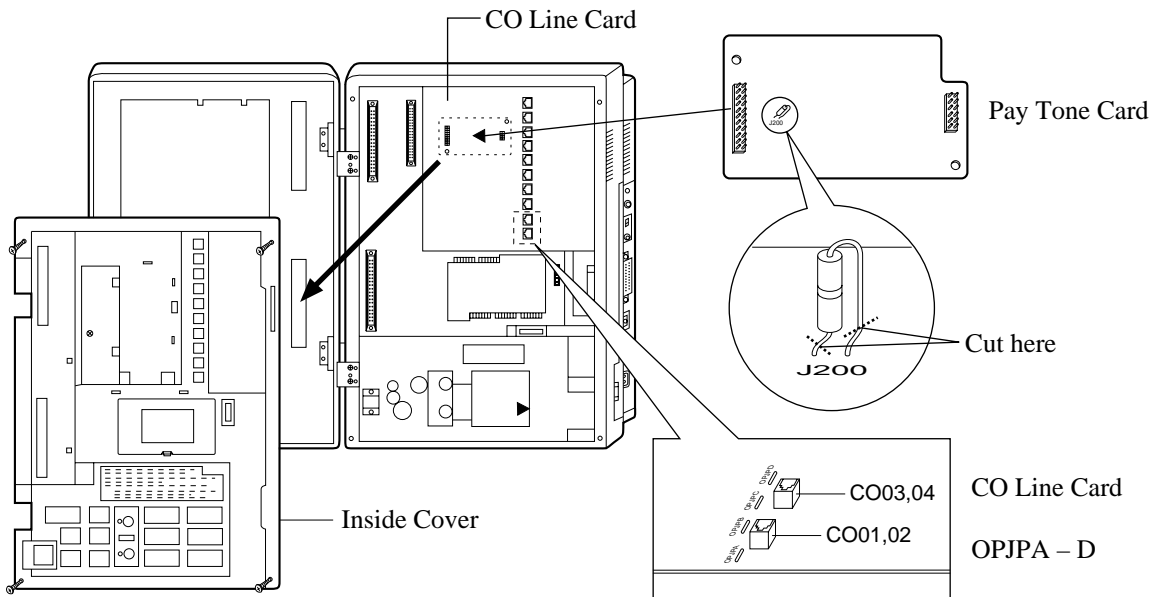

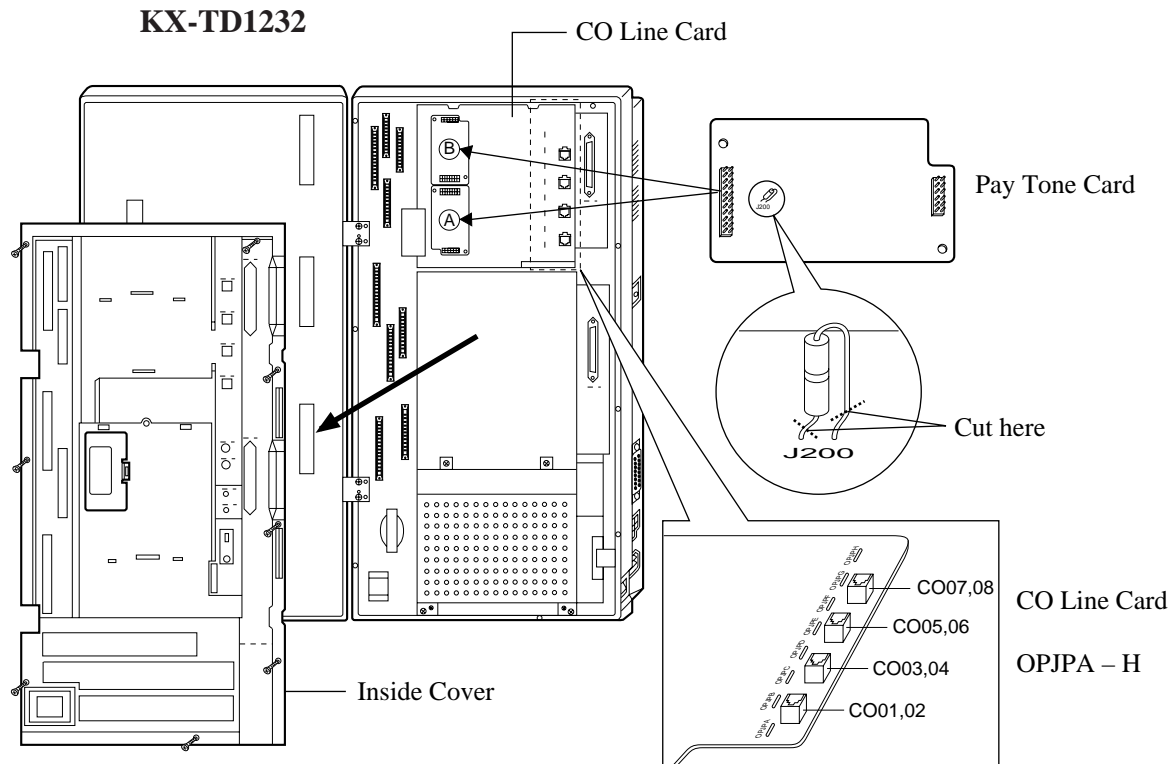

3. If you do not cut the wire of the J200 in Pay Tone Card, the detected mode is 16 KHz. If you cut the wire of the J200 in Pay Tone Card (Open Mode), the detected mode is 12 KHz.
4. After installing the Pay Tone Card, if you hear a noise of the pay-tone signal, cut the option Jumper Wires, OPJPA through OPJPH, in the CO Card.
 KX-TD816: OPJPA through OPJPD corresponds to outside line (CO) 01 through 04 respectively.
 KX-TD1232: OPJPA through OPJPH corresponds to outside line (CO) 01 through 08 respectively.
 <Example>
 - When you install the Pay Tone Card A, you will detect the pay-tone signal from outside line (CO) 01 through 04, and cut the corresponding option Jumper Wires, if needed.
 - When you install the Pay Tone Card B, you will detect the pay-tone signal from outside line (CO) 05 through 08, and cut the corresponding option Jumper Wires, if needed.
5. Put the inside cover back on the main unit and secure the screws.

Installing to the Optional 4-CO Line Unit

The following procedures must be done before installing the 4-CO Line Unit (KX-TD180) to the main unit.

1. Loosen five screws located on the rear of the 4-CO Line Unit.
2. Remove the back plate and take out the P-board.
3. Attach the Pay Tone Card (KX-TD189) to the P-board, fitting the connectors.
4. Put the P-board back into the cabinet and fix the rear plate with the five screws.
5. If you do not cut the wire of the J200 in Pay Tone Card, the detected mode is 16 KHz. If you cut the wire of the J200 in pay-tone card (Open Mode), the detected mode is 12 KHz.

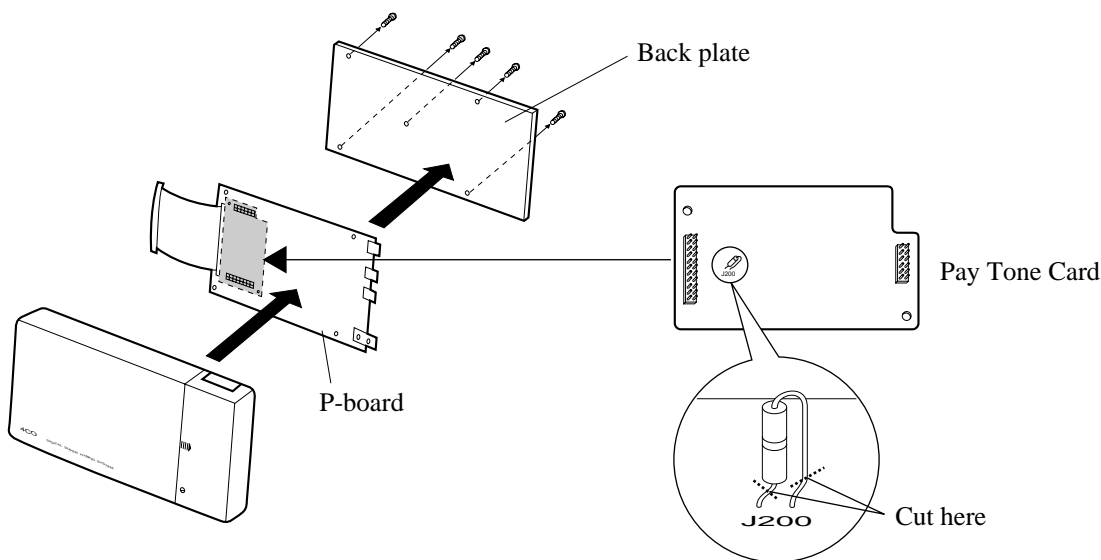

Note

To install the 4-CO Line Unit to the main unit, refer to Section 2.4.5 Installing Expansion Unit.

Programming Guide References

[423] Pay Tone Assignment

Features Guide References

Hotel Application

Incoming Outside Call Information Display

2.4.7 DISA Card / Unit and Remote Card / Unit Installation

The DISA Card (KX-TD191 and KX-TD199), DISA Unit (KX-TD190), Remote Card (KX-TD196), High Speed Remote Card (KX-TD197) and Remote Unit (KX-TD198) can be installed as follows.

Main Unit	For DISA feature	For remote access
KX-TD816	KX-TD190, KX-TD198 with KX-TD199	KX-TD198, KX-TD190 with KX-TD197
KX-TD1232	KX-TD191	KX-TD196, KX-TD197

The DISA Unit and the Remote Unit can also be attached with other line expansion unit.

KX-TD816

Installing the DISA Unit (KX-TD190) or Remote Unit (KX-TD198)

1. Loosen the two screws on the cover plate. Insert your fingers into the slits to remove the cover plate.

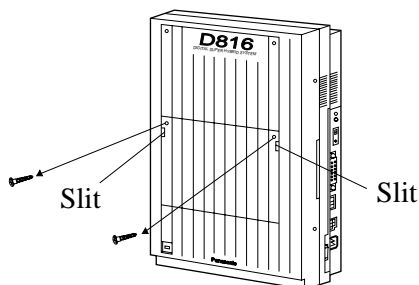

Note

There are two cover plates. Any of them can be removed, as needed.

2. Connect the cabinet cord to the connector in the main unit firmly.

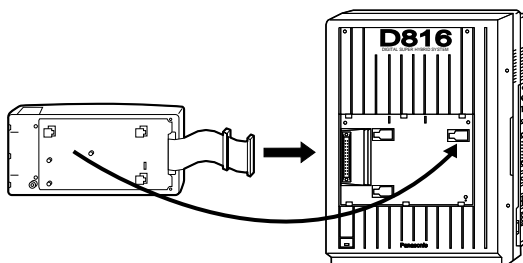

3. Hook the cabinet onto the main unit and slide the cabinet to the left until it is secured.

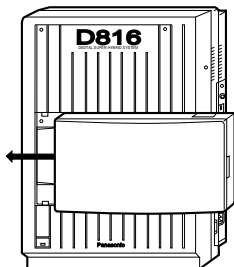

**Installing the DISA Card (KX-TD199) to the Remote Unit (KX-TD198) /
Installing the High Speed Remote Card (KX-TD197) to the DISA Unit (KX-TD190)**

It is possible to install the required card in the unit before installing the unit to the main unit. The illustrations below are the examples for installing the DISA Card to the Remote Unit.

1. Open the front cover of the unit, slide the side cover to the right and remove it.

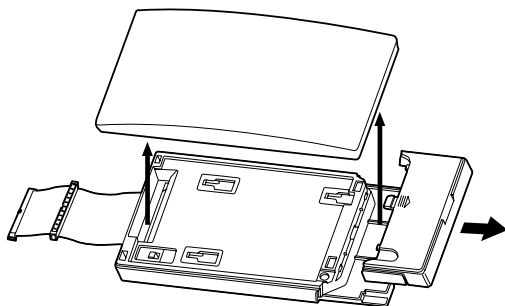

2. Turn over the unit and remove the four screws.

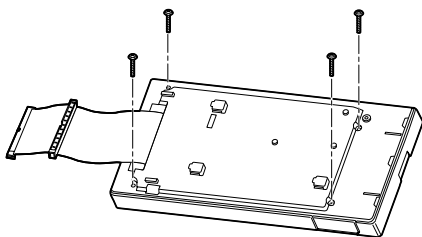

3. Turn over the unit again and remove the inside cover.

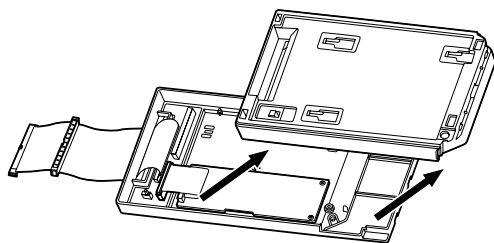

4. Install the card, secure the screw (included with the unit) and connect the cable to the connector.

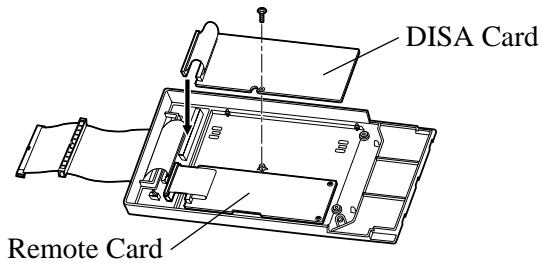

5. Flatten the cable to replace the inside cover properly.

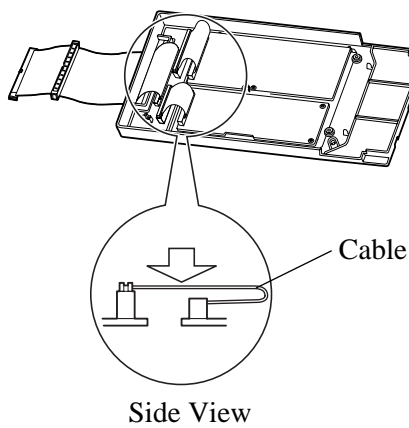

6. Replace the inside cover and secure the four screws on the back. Also, replace the side cover.
7. Set the MODE switch to 2.

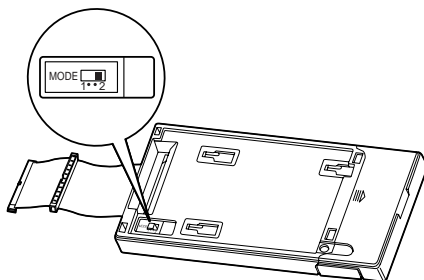

8. Replace the front cover.
9. Install the unit to the main unit.

Attaching another line expansion unit to the DISA Unit (KX-TD190) or Remote Unit (KX-TD198) and install them to the system

1. Remove the front cover of the DISA or Remote Unit.
The KX-TD198 users must set the MODE switch to 2.

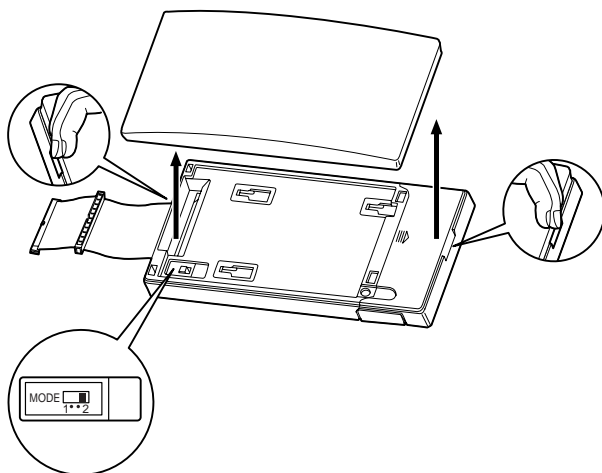

2. Attach the expansion unit to the DISA or Remote Unit as shown below. Be sure to connect the cabinet cords by inserting the expansion unit cabinet cord through the slot in the DISA or Remote Unit.

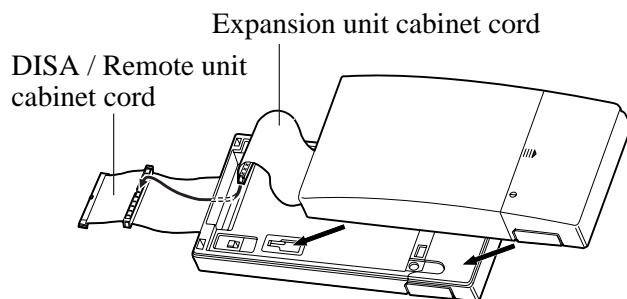

3. Remove the cover plate and connect the cabinet cord to the connector in the main unit firmly.

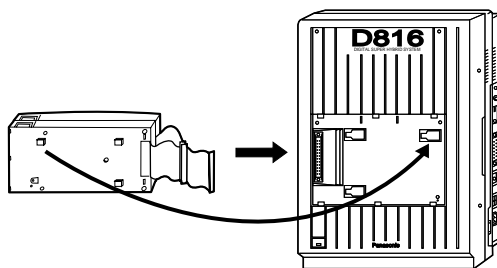

4. Hook the cabinets onto the main unit and slide the cabinets to the left until they are secured.

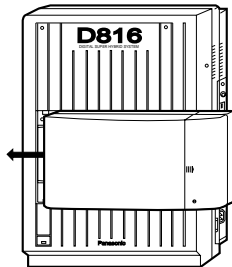

5. Loosen the outside screw of the expansion unit and slide the cover to the right.

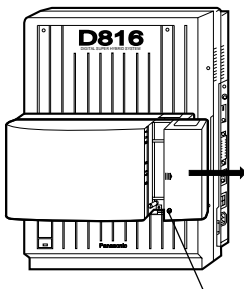

Outside screw

6. Secure the inside screw (included with the DISA or Remote Unit) to fix the cabinet to the main unit.

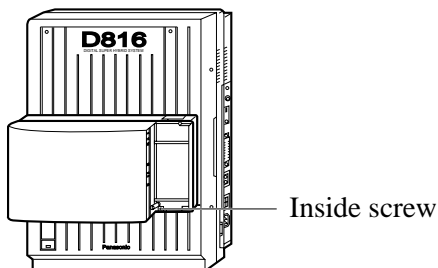

Inside screw

7. Tie all of the cords into a bundle. If other cords are exposed from the upper cabinets, tie them also.
8. Close the cabinet cover and secure the outside screw.
9. Cover the cords with the cord holder. If two cabinets are connected together and attached to the main unit, use the cord holder included with the DISA or Remote Unit.

10. Fix the cords to the wall as shown here, so that the front cover can be opened.

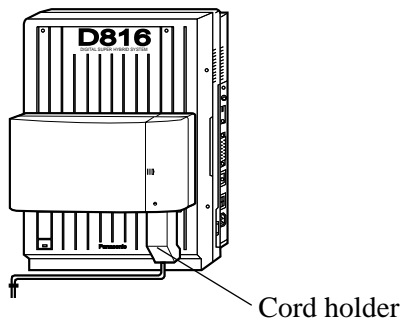

KX-TD1232

Installing the DISA Card (KX-TD191)

1. Insert the upper side of the DISA Card into the two hooks on the main unit.

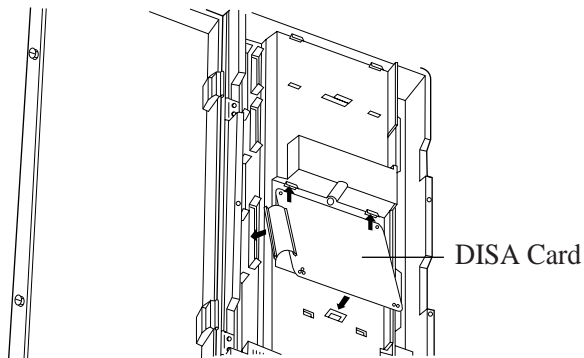

2. Press down the two corners of the lower side of the DISA Card.

3. Connect the cord to the DISA Card Connector.

Features Guide References

Direct Inward System Access (DISA)

Installing the Remote Card (KX-TD196) or High Speed Remote Card (KX-TD197)

1. Insert the upper side of the Remote Card into the two hooks on the main unit.

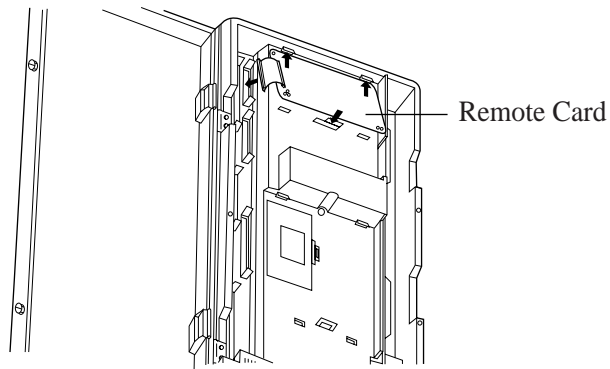

2. Press down the two corners of the lower side of the Remote Card.
3. Connect the cord to the Remote Card Connector.

Programming Guide References

- [107] System Password
- [813] Floating Number Assignment
- [814] Modem Standard
- [817] KX-TD197 Baud Rate Set

Features Guide References

System Programming and Diagnosis with Personal Computer

2.4.8 Doorphone and Door Opener Connection

To connect up to two doorphones (KX-T30865) and up to two door openers (user-supplied), a Doorphone Card (KX-TD160) is required.

Installing the Doorphone

1. Loosen the screw to separate the doorphone into two halves.

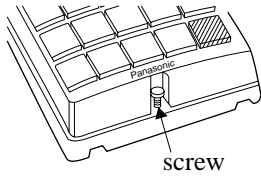

2. Install the base cover to the wall with two screws.

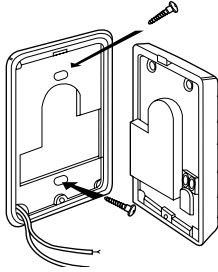

Note

Two kinds of screws are included. Please choose the appropriate one depending on your wall type:

 Type 1: When the doorphone plate has been fixed to the wall.

 Type 2: When you wish to install the doorphone directly to the wall.

3. Connect the wires to the screws located in the front cover.

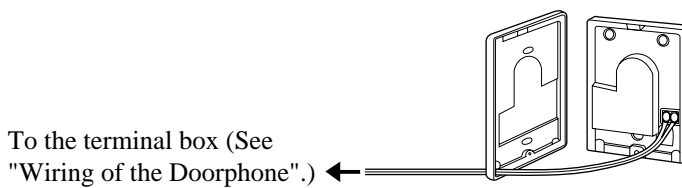

4. Secure both halves together and re-install the screw.

Doorphone Card Installation

1. Connect a 4-conductor modular connector to the Doorphone Card Cabinet, and pass the cord through the groove in the cabinet.

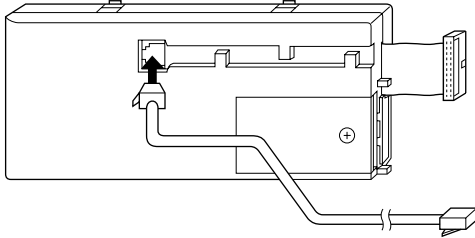

2. Attach the Doorphone Card Cabinet to the main unit and press down.
3. Connect the cord to the Doorphone Card Connector.

KX-TD1232

KX-TD816

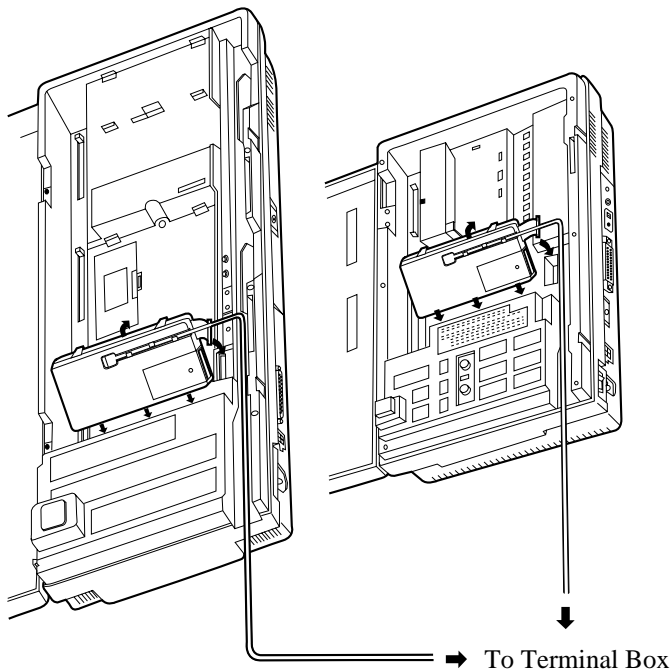

Wiring of the Doorphone

1. Connect the Doorphone Card to the terminal box using a 4-conductor modular connector.
2. Connect the wires of doorphone 1 to the red and green screws of the terminal box.
3. Connect the wires of doorphone 2 to the yellow and black screws of the terminal box.

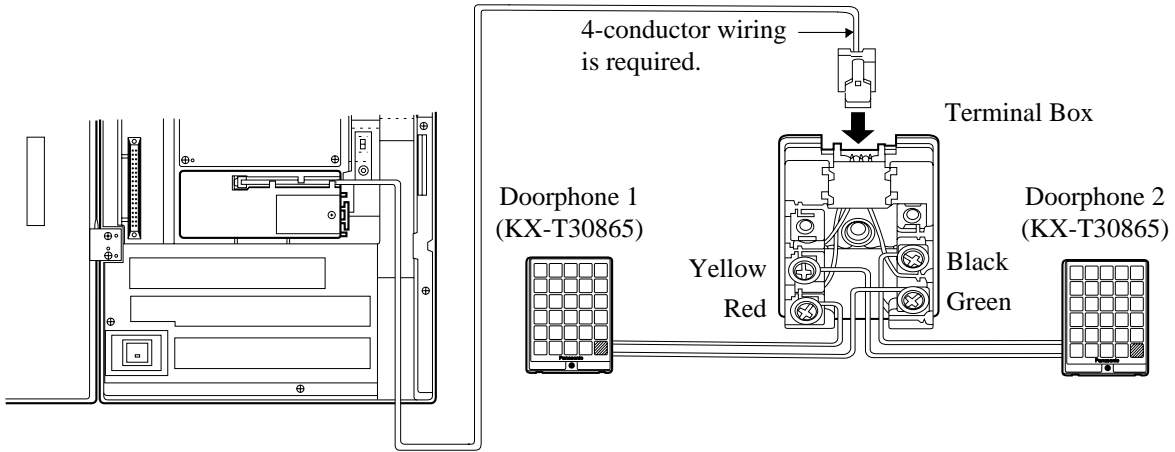

Note

The KX-TD1232 is illustrated as the main unit.

Connecting Door Openers

1. Loosen the screw to remove the cover.

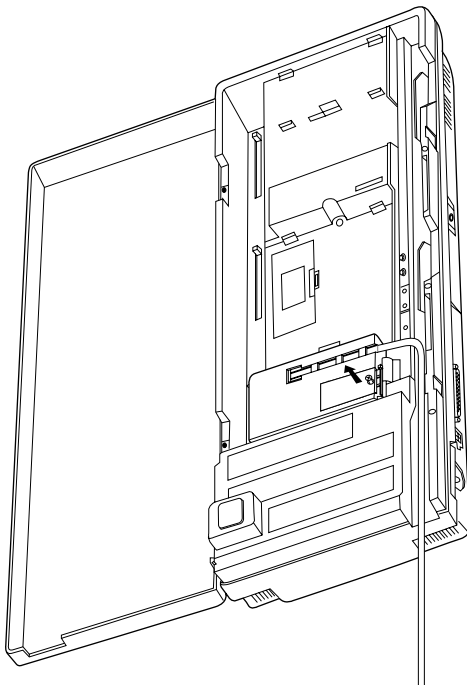

2. Loosen the screws on the terminal strip.

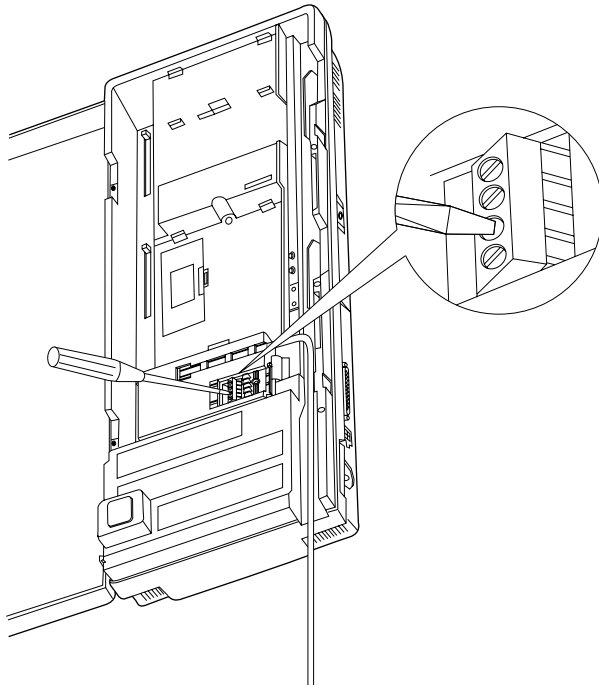

3. Insert the wires coming from the door openers into holes and tighten the screws.

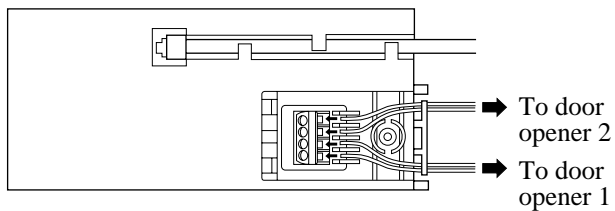

Note

- The KX-TD1232 is illustrated as the main unit.
- For wiring, UL 1015, AWG 22 twisted wire or the equivalent is recommended.
- The wire should be between 1.2 mm and 2.4 mm in diameter including the coating.

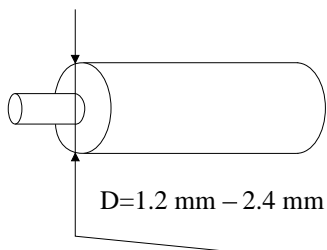

Maximum cabling distance of the doorphone and the door opener line

The maximum length of the doorphone and door opener line that connects to the main unit is shown below:

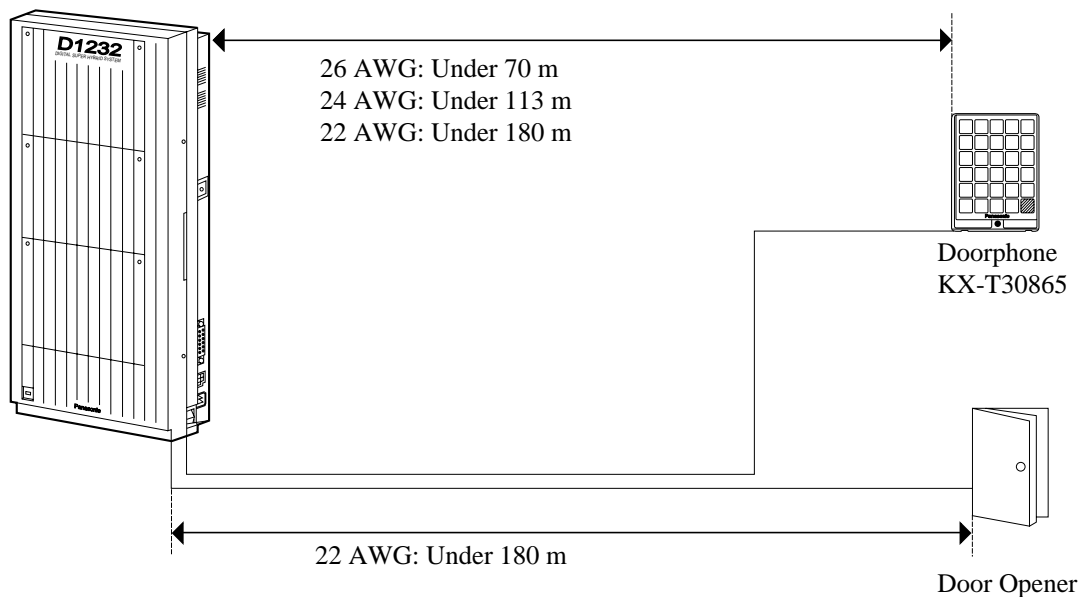

Note

The KX-TD1232 is illustrated as the main unit.

Programming Guide References

[607-608] Doorphone Ringing Assignment – Day / Night

[663-664] PS Doorphone Ringing Assignment – Day / Night

Features Guide References

Door Opener

Doorphone Call

2.4.9 SLT Message Waiting Lamp Adaptor Unit Connection

Name and Locations

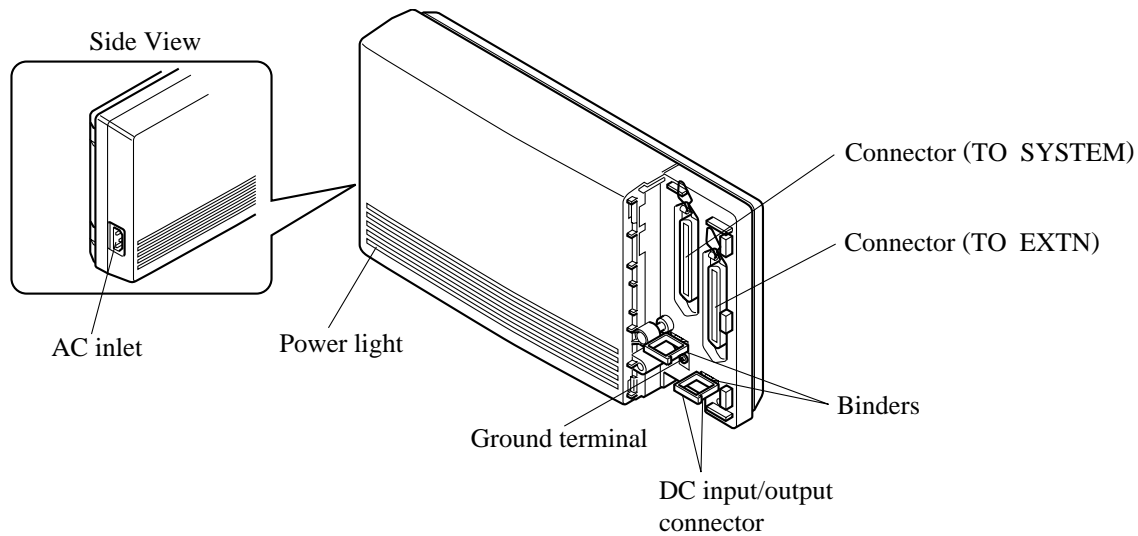

Specifications

1. General Description

Capacity	Corresponding extensions	16
Control Method	CPU: One-chip microcomputer Interface: 1-APT Interface	
Power Supplies	Primary Power	230 VAC, 50 Hz
	Secondary	Station Supply Voltage: + 85 V Circuit Voltage: + 5V, + 15 V
Connectors	Stations	50-pin Amphenol Connector
	DC Input/Output Interface	4-pin Connector

2. Characteristics

DC Power Supply to Stations	85 V, 1.2 mA (max)
Primary Power	230 VAC, 50 Hz, 0.8 A (max)* ¹
Environmental Requirements	0 °C – 40 °C, 10 % – 90 % rel. hum.

*¹ This is the maximum current when three TD194s are connected by DC input/output interfaces (only the main TD194 is connected to an AC outlet).

WARNING

THIS UNIT MAY ONLY BE INSTALLED AND SERVICED BY QUALIFIED SERVICE PERSONNEL.

Wall Mounting

This unit can be mounted to a wall. Refer to Section 2.2.3 Wall Mounting for details.

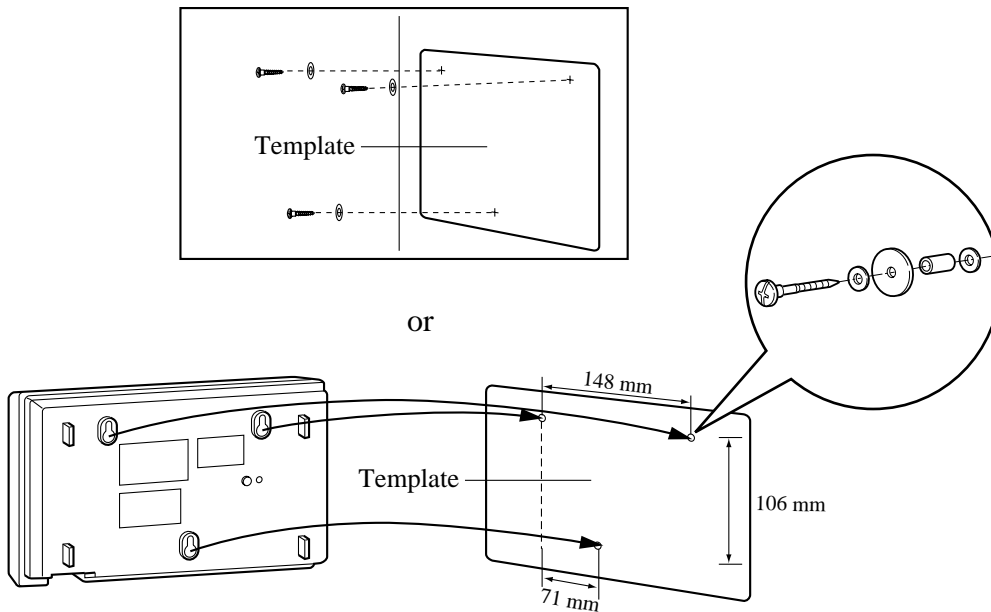

Opening the Front Cover

1. Loosen the screw.
2. Slide the cover while pressing the  mark.

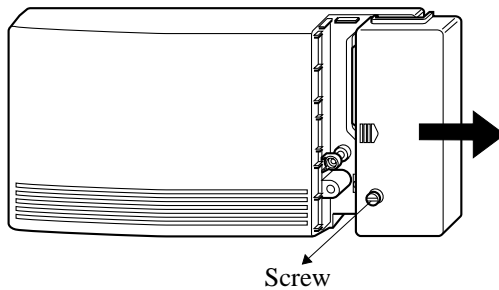

Note

The screw cannot be removed from the unit.

Frame Ground Connection

IMPORTANT

Connect the system frame to the ground.

1. Loosen the screw.
2. Insert the grounding wire.
3. Tighten the screw.
4. Connect the grounding wire to the ground.

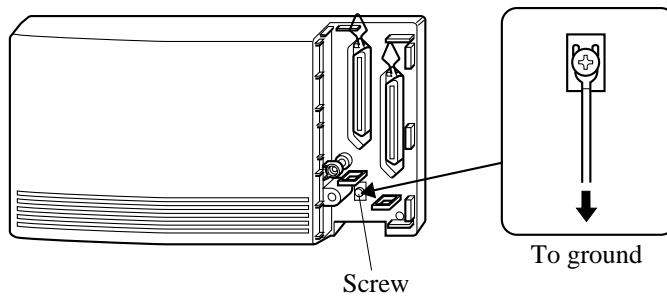

Inserting the Connector

1. Insert the two 50-pin connectors to the jacks as shown below.
The connector "TO SYSTEM" should be connected to the cable which is connected to the KX-TD816/KX-TD1232.
Also, the connector "TO EXTN" should be connected to the cable which is connected to the extensions.

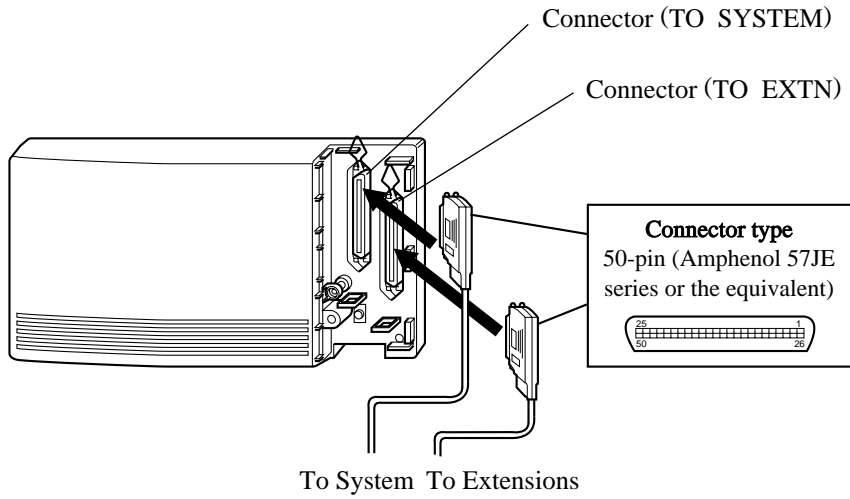

2. Insert the cables through the binders.

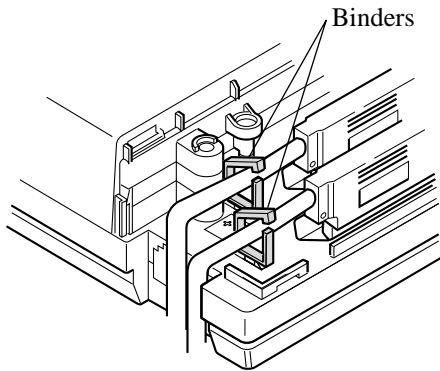

- If two units are connected with the DC IN/OUT or a Battery Adaptor (KX-A46) is connected to the unit, insert the 4-pin connectors to the jacks as shown below. Also connect the ground terminal of the unit to the minus (-) terminal of a car battery using an earth wire.

Note

Please make sure that the unused terminal* does not touch the car battery terminals.

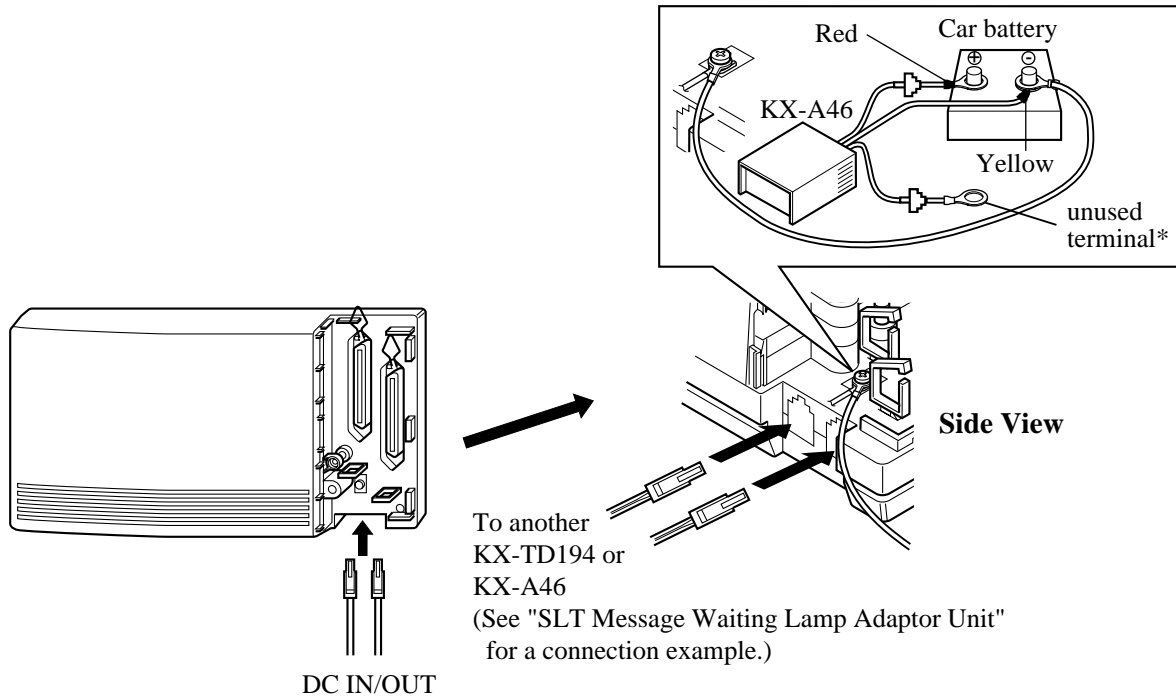

Pin Number Chart

CONN. PIN	To System Connector (CN1)	To Extension Connector (CN2)		
26 1	APT DATA	D1 D2	EXTN. 01	T R
27 2	EXTN. 01	T R	EXTN. 02	T R
28 3	EXTN. 02	T R	EXTN. 03	T R
29 4	EXTN. 03	T R	EXTN. 04	T R
30 5	EXTN. 04	T R	EXTN. 05	T R

CONN. PIN	To System Connector (CN1)		To Extension Connector (CN2)	
31 6	EXTN. 05	T R	EXTN. 06	T R
32 7	EXTN. 06	T R	EXTN. 07	T R
33 8	EXTN. 07	T R	EXTN. 08	T R
34 9	EXTN. 08	T R	EXTN. 09	T R
35 10	EXTN. 09	T R	EXTN. 10	T R
36 11	EXTN. 10	T R	EXTN. 11	T R
37 12	EXTN. 11	T R	EXTN. 12	T R
38 13	EXTN. 12	T R	EXTN. 13	T R
39 14	EXTN. 13	T R	EXTN. 14	T R
40 15	EXTN. 14	T R	EXTN. 15	T R
41 16	EXTN. 15	T R	EXTN. 16	T R
42 17	EXTN. 16	T R		

Closing the Front Cover

1. Fasten the binders.

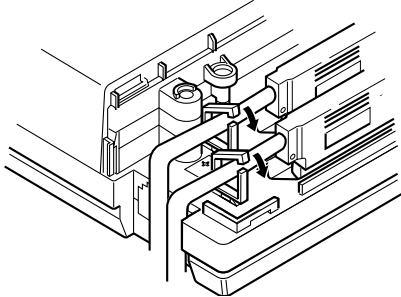

2. Replace the cover and tighten the screw.

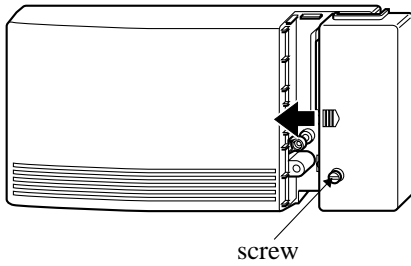

3. Tie together all of the connected cords and attach them to the wall so that the cords cannot be pulled out of the system.

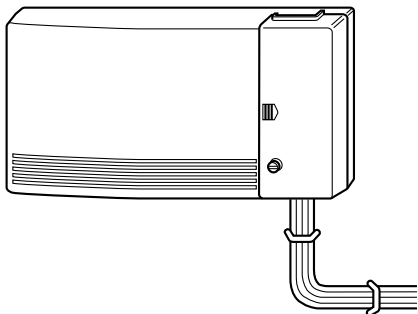

Starting the unit

Plug the AC cord into the system AC inlet and an AC outlet.

Avoid sharing the AC outlet of this system with other office equipment. Use a dedicated AC outlet only.

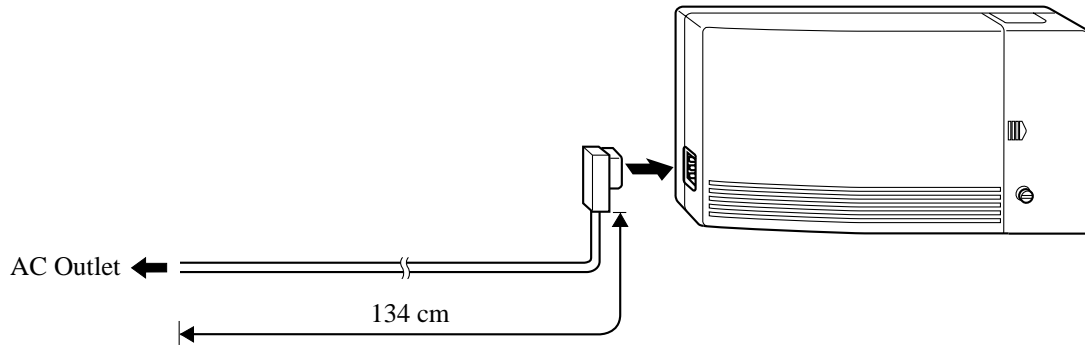

CAUTION

The power supply cord is used as the main disconnect device. Ensure that the socket-outlet is located/installed near the equipment and is easily accessible.

2.4.10 System Connection*1

To connect two main units, use two optional System Inter Connection Cards (KX-TD192) and the Connection Cable (included in the cards).

1. Insert the upper side of the System Inter Connection Card into two hooks on the main unit (Master System).
2. Press down the two corners of the lower side of the System Inter Connection Card.
3. Connect the cord to the System Inter Connection Card connector.

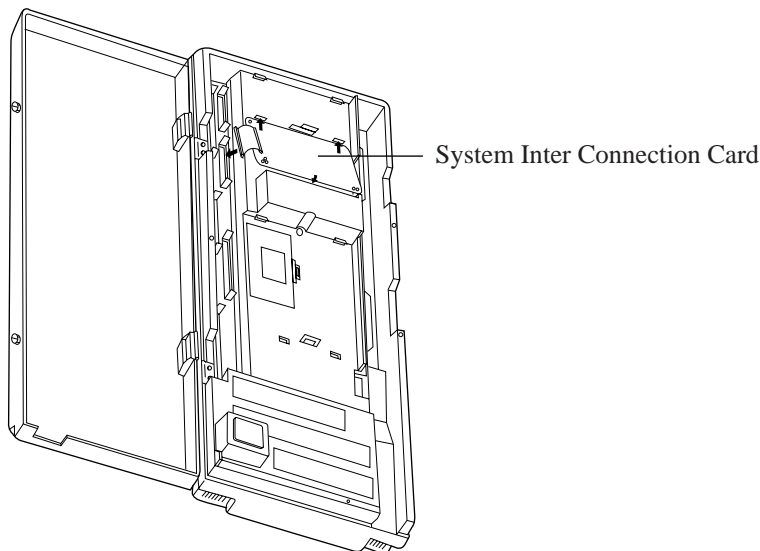

4. Open the latch on the card.
5. Repeat steps 1 through 4 for the Slave System, using the other card.
6. Insert one Connection Cable end into the Master System and insert the other end into the Slave System.

*1 Available for the KX-TD1232 only.

7. Close the latches on both systems.

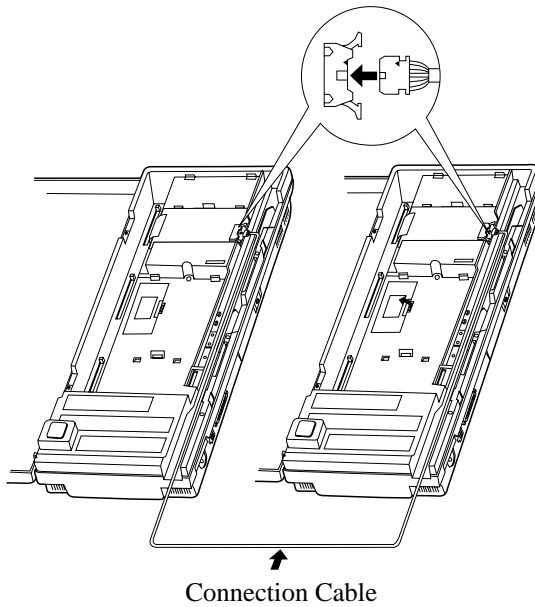

8. Open the ROM Cover in the Slave System and set the Master/Slave Switch on the CPU Card to "Slave" position.

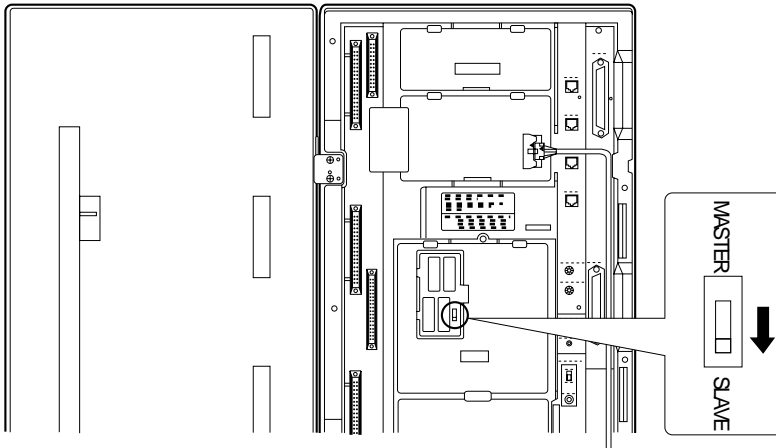

9. Turn the power on.

Note

- System Connection may take a while (5 to 15 min depending on your software version) to be completed after the power is turned on. Confirm the connection between the Systems by making a call from a Master System extension to a Slave System extension.
- To turn the power on for the first time, refer to Section 2.7.1 Starting the System for the First Time.
- The master and slave must have the same version software. Otherwise, System Connection will not work properly.

Feature Reference

System Connection

2.4.11 Battery Adaptor Connection

User-supplied car batteries can be used as a backup power supply in the event of a power failure. In case of a power failure, the batteries automatically maintain power to the main unit. The optional Battery Adaptor (KX-A46) is required.

The Battery Adaptor should not be exposed to direct sunlight. Keep the adaptor and car batteries away from heating appliances and fire. Place car batteries in a well ventilated place.

Connection

When connecting the battery adaptor, keep the following in mind.

- Check the polarities of batteries and wires.
- Make sure that you do not short the batteries and wires.
- To connect the two batteries, use an accessory wire.

1. Assemble the cords and two car batteries (12 VDC each) as shown.

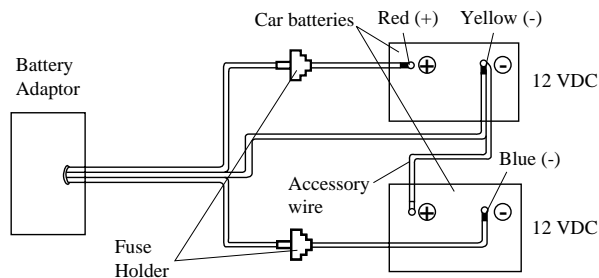

2. Insert the plug of the battery adaptor into the battery adaptor connector on the main unit. Connect the ground wire to the ground terminal on the main unit.

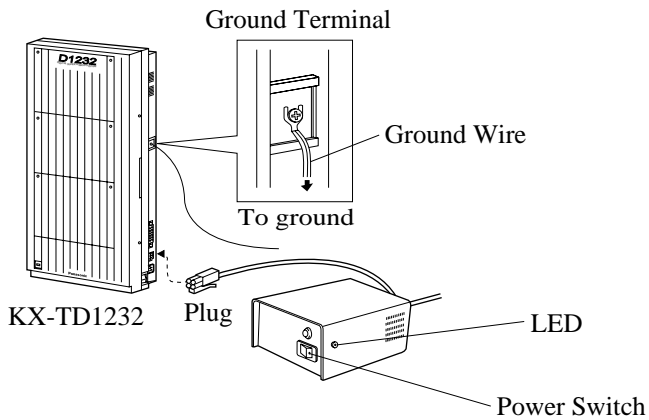
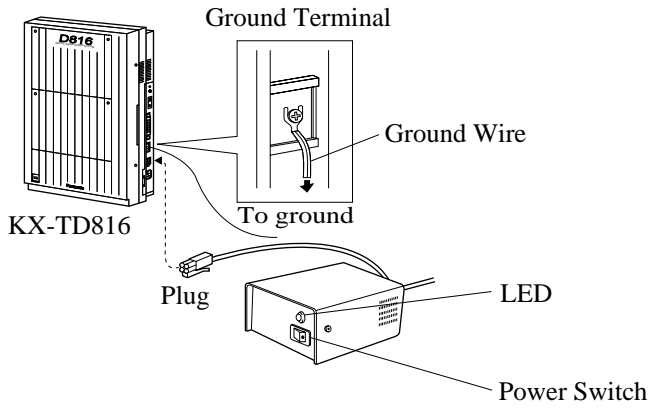

3. Turn on the power switch of the battery adaptor.

Wall Mounting

1. Drive the four small accessory screws into the bottom of the unit.
2. Place the metal plates so that the screw heads insert into the slots as shown.
3. Slide the metal plates in the direction of the arrows, and drive the screws.
4. Place the template on the wall to mark two screw positions, and install the big screws into the wall.

5. Hook the battery adaptor onto the screw heads.

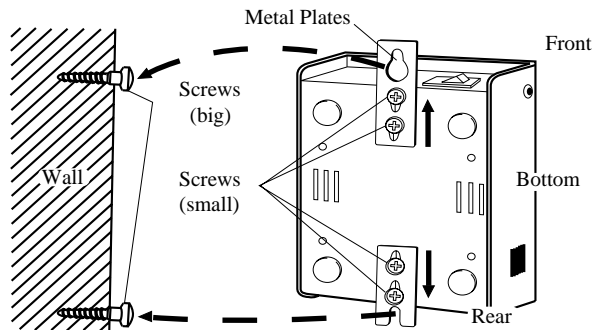

Mounting on Concrete or Mortar Walls;

At step 4, drill two holes and drive the anchor plugs with a hammer, flush to the wall, and install the big screws into the anchor plugs.

Note

- If the Power LED does not go on, check the main unit, battery adaptor, batteries and wiring connection.
- After connection of the battery adaptor, keep the power switch on unless when the main unit is turned off. (Batteries will discharge.)
- To charge the discharged batteries, use a proper charging unit.
- Power Fuse: (8 A, 32 V) × 2
If the Power LED light goes off during a power failure, the power fuse may have been blown. To change the fuse:

1. Turn the power switch off.
2. Turn the fuse holder in the direction of Arrow ② while pushing it in the direction of Arrow ①.
3. Change the fuse.
4. Turn the fuse holder in the direction of Arrow ③ while pushing it in the direction of Arrow ①.
5. Turn the power switch on.

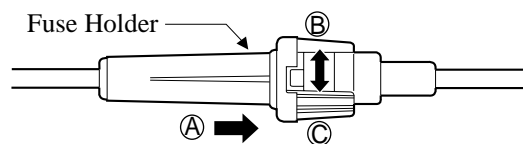

- Back-up Duration: depends on the amp-hour rating of the batteries used.
E.g. When using two 12 VDC batteries 20 amp-hour, maintenance-free, car batteries, the power is maintained for about three hours.

2.5 Auxiliary Connection for Power Failure Transfer

2.5.1 Auxiliary Connection for Power Failure Transfer

Power Failure Transfer connects specific single line telephones to selected outside lines in the event of system power failure, as follows:

KX-TD816

Outside Line 01 — Extension (T, R) Jack 01 /

Outside Line 02 — Extension (T, R) Jack 02 /

Outside Line 05 — Extension (T, R) Jack 09 /

Outside Line 06 — Extension (T, R) Jack 10

Connections of outside lines 1, 2 and the respective extensions require no auxiliary connection.

Outside lines 05 and 06 require auxiliary connection to implement this feature.

KX-TD1232

Outside Line 01 — Extension (T, R) Jack 01 /

Outside Line 02 — Extension (T, R) Jack 02 /

Outside Line 03 — Extension (T, R) Jack 09 /

Outside Line 04 — Extension (T, R) Jack 10 /

Outside Line 09 — Extension (T, R) Jack 17 /

Outside Line 10 — Extension (T, R) Jack 18

Connections of outside lines 01 through 04 and the respective extensions require no auxiliary connection. Outside lines 09 and 10 require auxiliary connection to implement this feature.

Insert the modular plugs of connection cords (4-conductor wiring) to the modular jacks of 4-CO Line Unit and Extension Line Unit 1.

(In the case of KX-TD816, one Extension Line Unit is available.)

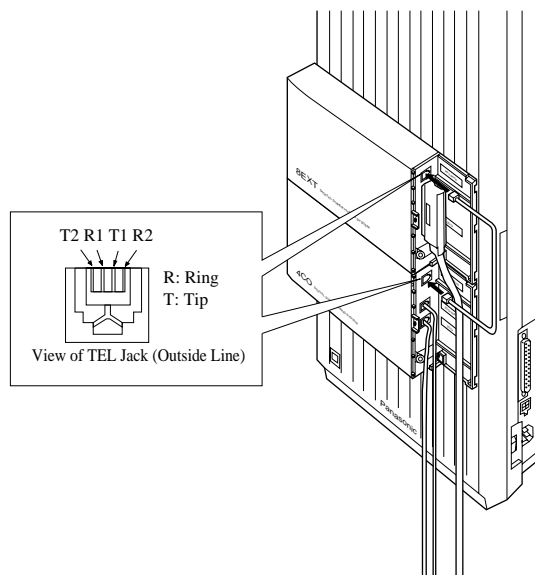

Note

- In the event of a power failure, system memory is protected by a factory-provided lithium battery. There is no memory loss except the memories of Camp-on, Saved Number Redial, Last Number Redial, Call Park and Message Waiting.
- The system changes the current connection to this connection automatically when the power supply stops.
- If DC power is available from backup batteries if AC power fails, the system does not change the current connection to the above connection.
- The KX-TD1232 is illustrated as the main unit, and the KX-TD170 and KX-TD180 are illustrated as the expansion units.

Features Guide References

Power Failure Transfer

2.6 Closing the Front Cover

2.6.1 Closing the Front Cover

1. Fasten all the cables and cords with the cord fastener.

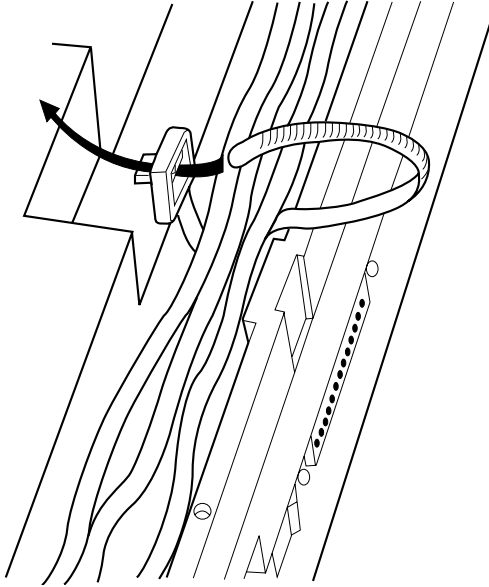

2. Replace the cover and tighten the screw.

Note

Be sure to tighten two screws, or the unit may not work properly.

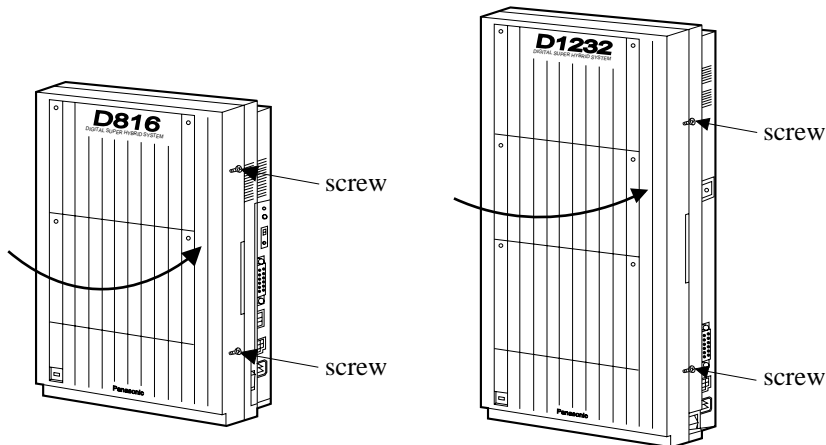

3. Tie together all of the connected cords and attach them to the wall so that the cords cannot be pulled out of the main unit.

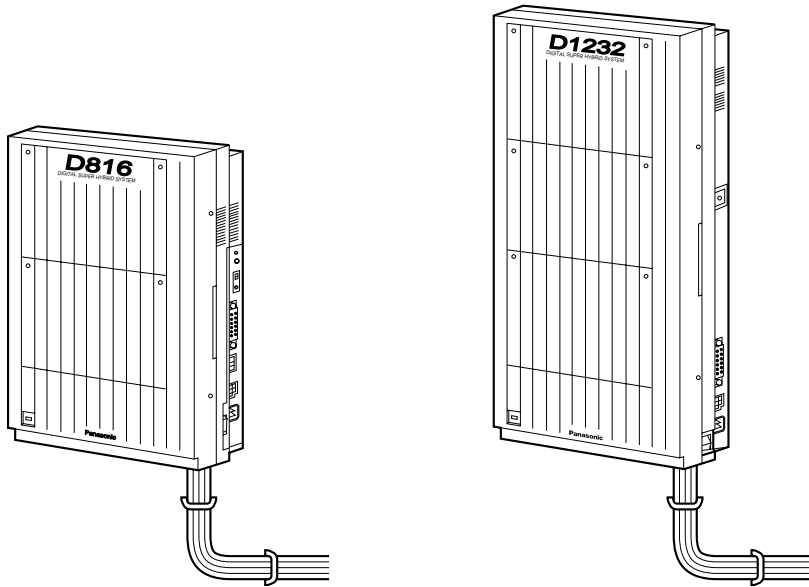

2.7 Starting the System for the First Time

2.7.1 Starting the System for the First Time

1. Set the Power Switch to the "OFF" position.
2. Set the System Clear Switch to the "CLEAR" position.
3. Plug the AC power cord into the system and an AC outlet.
4. Turn the Power Switch on.
5. Press the Reset Button with a pointed tool.
(The power indicator will flash.)
6. Slide the System Clear Switch to the "NORMAL" position while the power indicator is flashing (within approximately 10 seconds).

The system will be initialised with default values. The system will also check the outside lines, extensions, and optional cards and units.

KX-TD816

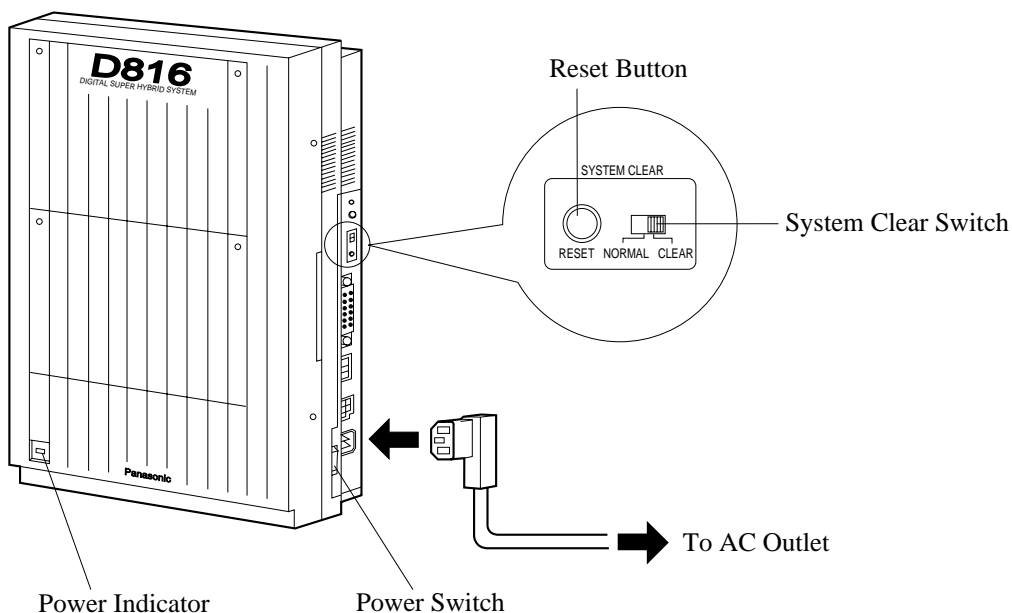

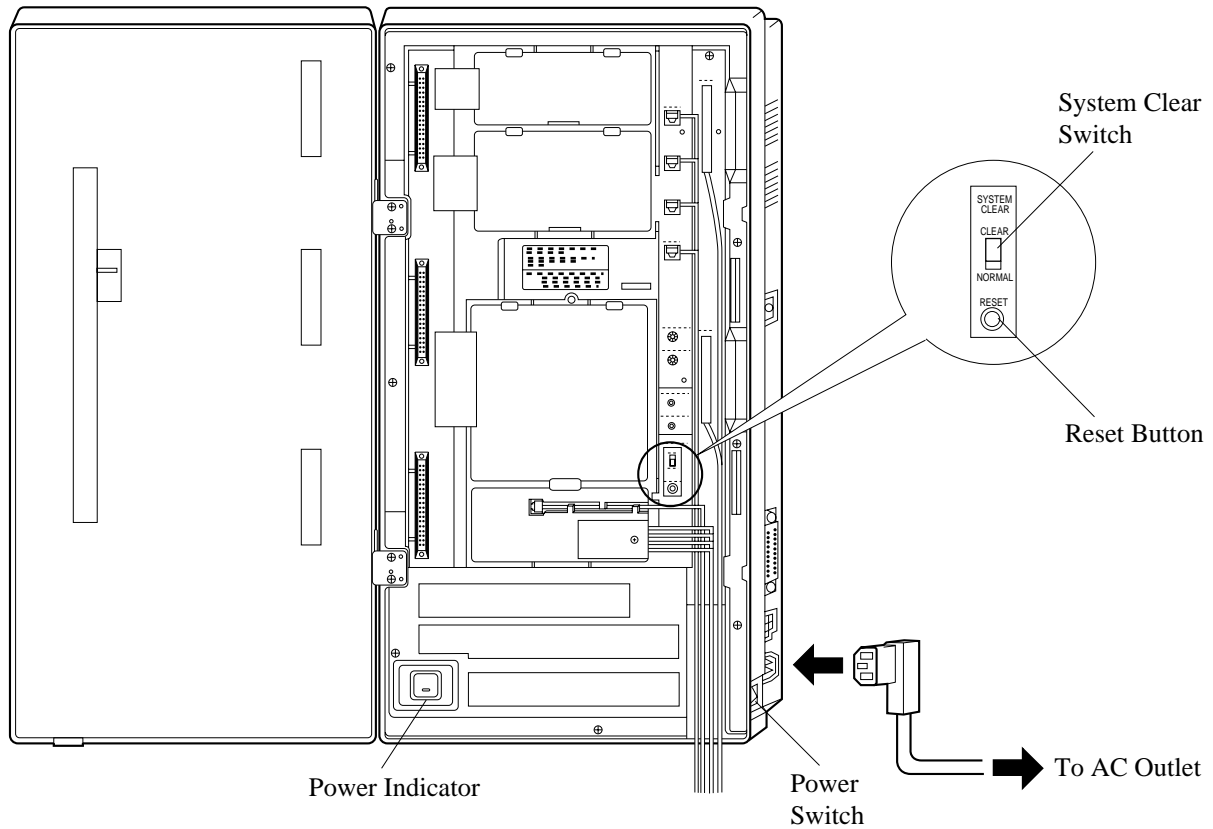
KX-TD1232**Notice**

- After pressing the Reset Button, slide the System Clear Switch to the "NORMAL" position at step 6 while the power indicator is flashing (within approximately 10 seconds). Otherwise, the system will not start up with the default values.

CAUTION

Once you start up the system and you turn the power off, do not perform the above procedure to start the system again. Otherwise, your programmed data will be cleared. To start the system, just turn the Power Switch on.

The power outlet should be located near this equipment and easily accessible.

2.8 System Restart

2.8.1 System Restart

After starting the system, if the system does not operate properly, restart the system. Before restarting the system, try the system feature again to confirm whether there definitely is a problem or not.

System Restart causes the following:

- a) Camp-on is cleared.
- b) Calls on Hold are terminated.
- c) Calls on Exclusive Hold are terminated.
- d) Calls in progress are terminated.
- e) Call Park is cleared.

Other data is not cleared by System Restart.

1. Make sure that the System Clear Switch is set to the "NORMAL" position.
2. Press the Reset Button with a pointed tool.

Notice

After pressing the Reset Button, if you notice that the System Clear Switch is set to the "CLEAR" position, never slide the System Clear Switch to the "NORMAL" position within 20 seconds. Otherwise, all the system programming data are reset to default values (Refer to Section 2.9.1 System Data Clear). Wait at least 30 seconds, then slide to the "NORMAL" position. Then the system will work as before.

If the system still does not operate properly, please see Section 6.1.4 Using the Reset Button.

2.9 System Data Clear

2.9.1 System Data Clear

After storing or changing the system programming data, it is possible to clear your programming data stored in the system, if required. The system will restart with the default setting.

1. Slide the System Clear Switch to the "CLEAR" position.
2. Press the Reset Button with a pointed tool.
3. Return the System Clear Switch to the "NORMAL" position while the power indicator is flashing (within approximately 10 seconds).

Notice

After pressing the Reset Button, return the System Clear Switch to the "NORMAL" position in step 3 while the power indicator is flashing (within approximately 10 seconds). Otherwise, the system will not clear.

Section 3
ISDN Installation

3.1 ISDN Network Outline

3.1.1 Overview

To use the ISDN Line Service, the following unit can be installed to the KX-TD816 and KX-TD1232.

2-ISDN S0 Line Unit (KX-TD280)

This unit adds two Basic Rate Interface (BRI) ISDN S0 lines. One KX-TD280 can be connected to the KX-TD816 and KX-TD1232.

6-ISDN S0 Line Unit (KX-TD286)

This unit adds six Basic Rate Interface (BRI) ISDN S0 lines. One KX-TD286 can be connected to the KX-TD816 and KX-TD1232.

When the KX-TD286 is installed in the KX-TD816, only four ISDN S0 lines are available for outside lines and the other ports are for extension lines (ISDN extensions).

Primary Rate Interface ISDN Expansion Unit (KX-TD290)

This unit adds one Primary Rate Interface (PRI) ISDN line. This unit can be only installed to the KX-TD1232 Master system.

When this unit is installed to the system, the maximum number of available outside lines is limited to 42. Outside lines 13 through 24 will become unavailable if the Slave system is operating.

One PRI ISDN line adds 30 outside lines (outside lines 25 through 54) to the system.

Notice

- The ISDN Line Units (e.g. KX-TD280) are in accordance with the European Telecommunication Standards (ETS).
If your telephone company provides an ISDN service which follows the standards other than ETS, some ISDN features in the Features Guide may not work properly. (e.g. Charge Fee Reference, CLIP, COLP, etc.)
- To use the point-to-multi-point configuration with the KX-TD286, the number on the name plate, which is on the back of the unit, must be ④ or later.
- **ISDN Interface**
ISDN provides the following two interfaces.
Basic Rate Interface (BRI):
BRI provides two 64 kbps B channels for voice / data transmission and one 16 kbps D channel for signalling (2B + D).
Primary Rate Interface (PRI):
PRI provides thirty 64 kbps B channels for voice / data transmission and one 64 kbps D channel for signalling (30B + D).

3.2 ISDN Line Connection

3.2.1 Location of the Units

Precautions To protect the printed circuit boards (P-boards) from static electricity, do not touch parts on the P-boards in the main unit and on the optional units. The ISDN line unit should not be installed only to the Slave system.

KX-TD816

One ISDN Line Unit (KX-TD280 or KX-TD286) can be installed to any expansion area.

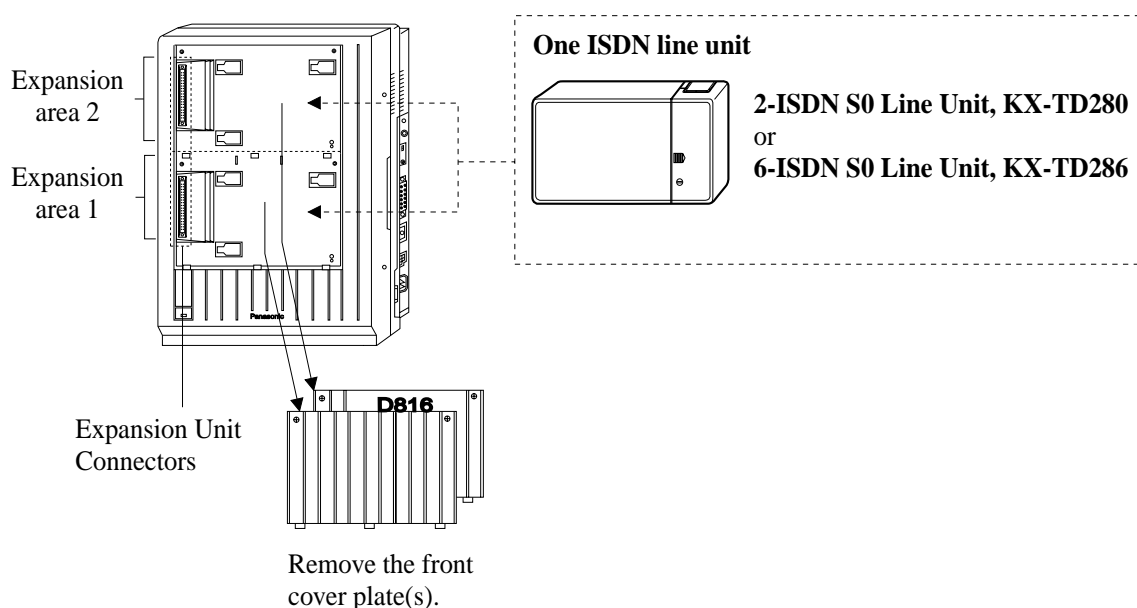

Note

- System Programming is required for expansion unit location.
<SYS PRG [109]>
Default : Area 1 = 4-CO Line Unit
Area 2 = 8-Station Line Unit
- When starting the system for the first time or performing System Data Clear, the location application will use the actual installation settings instead of the system default settings.
- Either one KX-TD280, one KX-TD286 or one KX-TD180 can be installed in a system.
- For unit combinations, refer to Section 1.4.2 Expansion Unit Combination.

KX-TD1232

One ISDN Line Unit (KX-TD280 or KX-TD286) and/or one PRI ISDN Line Unit (KX-TD290) can be installed to any expansion area.

The KX-TD290 can be installed with the KX-TD280 or KX-TD286, but not with the analogue outside line unit. If you use the KX-TD170 or KX-TD174 with the KX-TD290, you must use the KX-TD170-② or KX-TD174-②. The former unit does not work properly with the KX-TD290.

Please see the back of the unit and check "②" is marked.

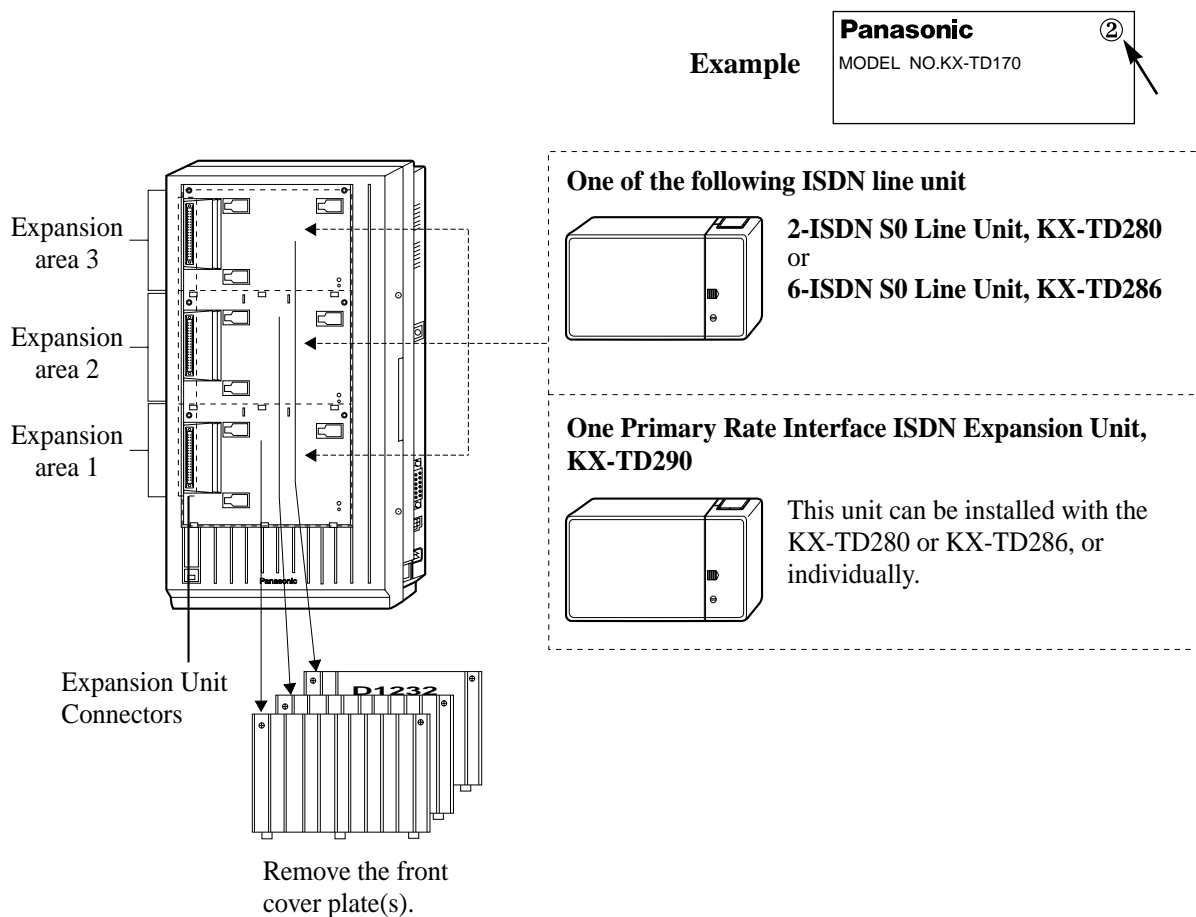

Note

- System Programming is required for expansion unit location.
<SYS PRG [109]>
Default : Area 1 = 4-CO Line Unit
Area 2 and 3 = 8-Station Line Unit
- When starting the system for the first time or performing System Data Clear, the location application will use the actual installation settings instead of the system default settings.
- Either one KX-TD280, one KX-TD286 or one KX-TD180 can be installed in a system.
- For unit combinations, refer to Section 1.4.2 Expansion Unit Combination.

3.2.2 Installing the Unit

Step 6 is different for each unit.

The ISDN unit should not be installed only to the Slave system.

The KX-TD1232 is illustrated as the main unit.

1. Loosen two screws on the cover plate. Insert fingers into the slits to remove the cover plate.

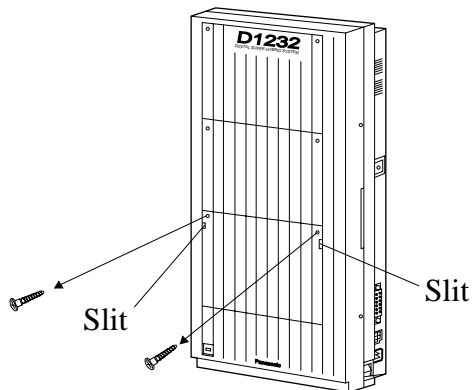

Note

Any of the cover plates can be removed, as needed.

2. Connect the cabinet cord to the connector in the main unit firmly.

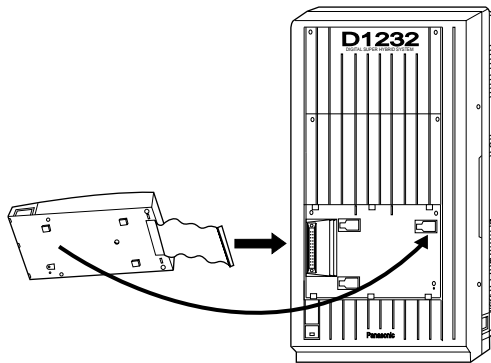

- Hook the cabinet to the main unit and slide the cabinet to the left until it is secured.

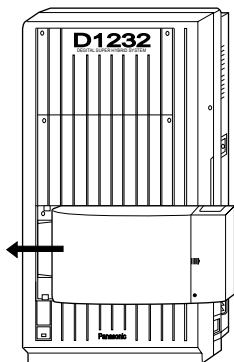

- Loosen the outside screw and slide the cover to the right.

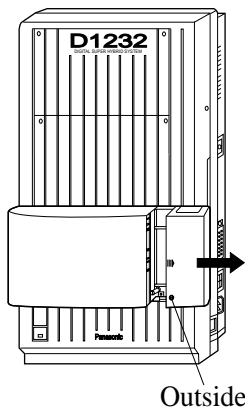

- Secure the inside screw (included) to fix the cabinet to the main unit.

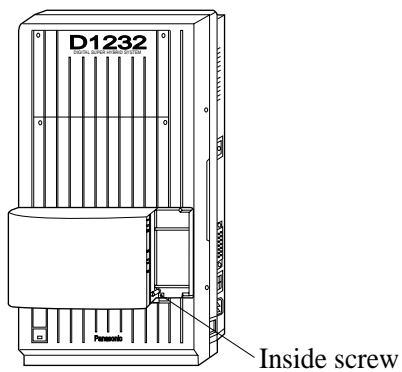

Note

Be sure to fix the inside screw to the main unit, or the unit may not work properly.

6. If a KX-TD280 or KX-TD286 is to be installed:

- a) Prepare the required plugs. Two 4-pin plugs are included in KX-TD280, and six 4-pin plugs are included in KX-TD286 to connect outside lines.

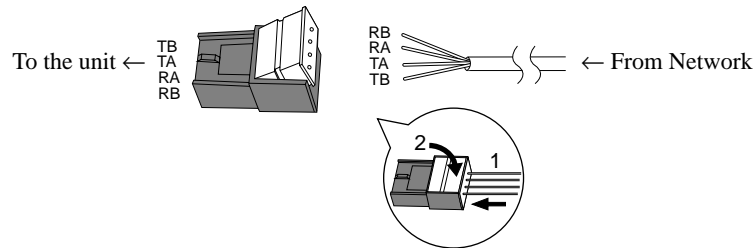

- b) Insert the plug into a jack on the unit.

Connect a grounding wire to the ground terminal on the KX-TD280 or KX-TD286.

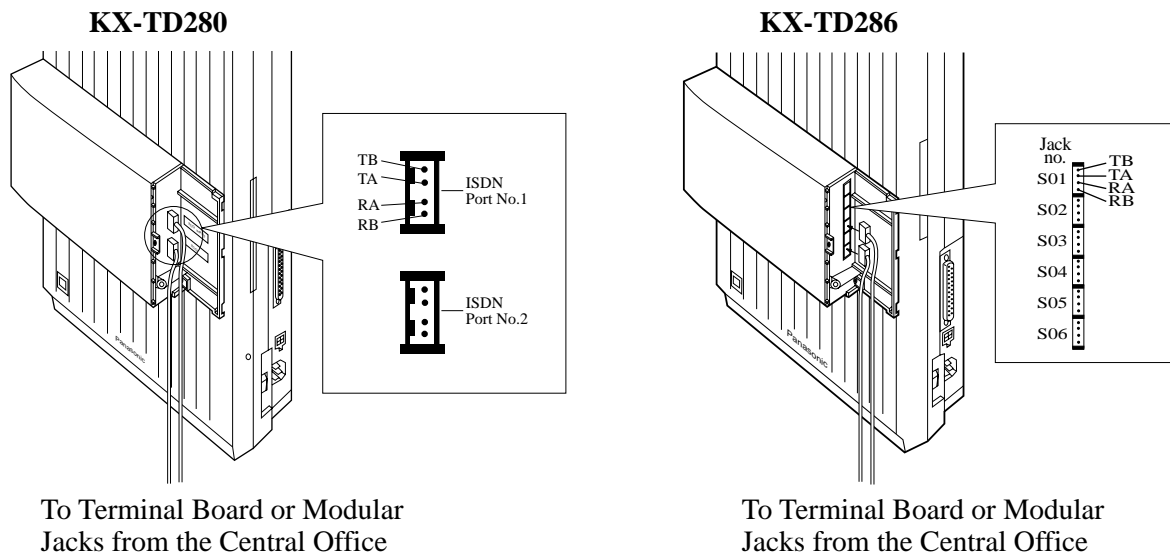

Note

All ports of the KX-TD280 and KX-TD286 can also be used for internal ISDN lines. For the KX-TD816, jack numbers S05 and S06 of the KX-TD286 are fixed as internal ISDN lines. To connect internal ISDN lines, refer to Section 3.2.3 Internal ISDN S0 Line Connection.

If a KX-TD290 is to be installed (KX-TD1232 only):

- a)** Prepare the required plugs. Two 4-pin plugs are included with the KX-TD290.

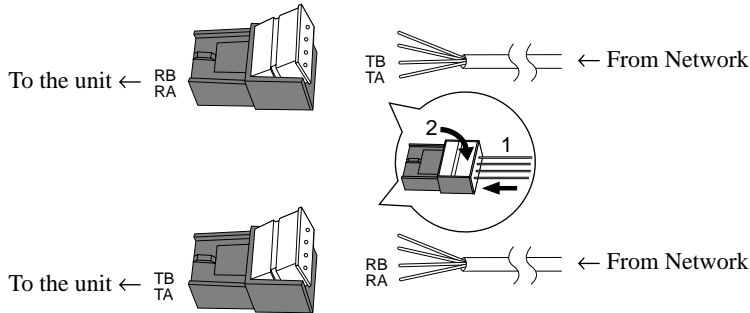

- b)** Insert the plug into a jack on the unit.
Connect a grounding wire to the ground terminal on the extension expansion unit.

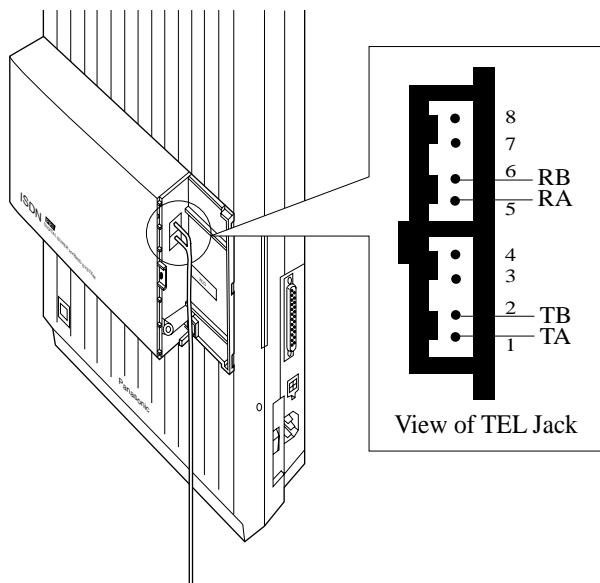

To Terminal Board or Modular
Jacks from the Central Office

- 7.** Tie all of the cords into a bundle. If other cords are exposed in the upper cabinets, tie them also.
- 8.** Close the cabinet cover and secure the outside screw.

9. Cover the cords with the cord holder (included).

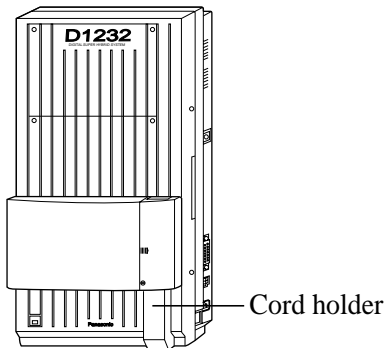

10. Fix the cords to the wall as shown so that the front cover can be opened.

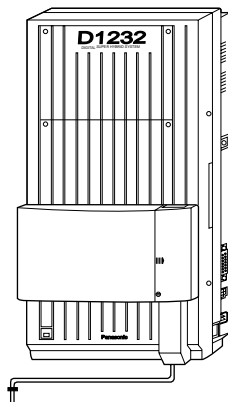

Note

If two or three expansion units are installed, cut the cabinet covers on the lower cabinets to allow the cords from the upper cabinet to go down through the cabinet covers. To protect the cords, smooth the cut edges.

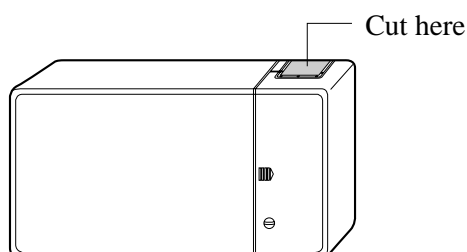

Programming Guide References

[109] Expansion Unit Type

3.2.3 Internal ISDN S0 Line Connection

The ISDN S0 Bus on the 2-ISDN S0 Line Unit (KX-TD280) and the 6-ISDN S0 Line Unit (KX-TD286) can be used as internal S0 bus. Each port can be used as either external or internal ISDN S0 Lines. Some System Programmes are required to use the S0 bus as internal ISDN S0 lines beforehand.

Connection

Use 4-pin plugs (included) to connect ISDN S0 lines. A single plug is able to connect one ISDN S0 line. Mis-connection may cause the system to operate improperly.

1. Re-arrange telephone wires in reverse order of the plug.

Wiring for external ISDN S0 line

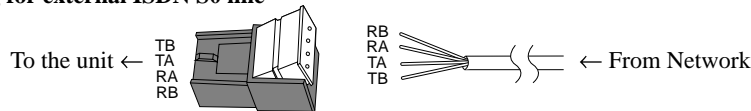

Wiring for internal ISDN S0 line

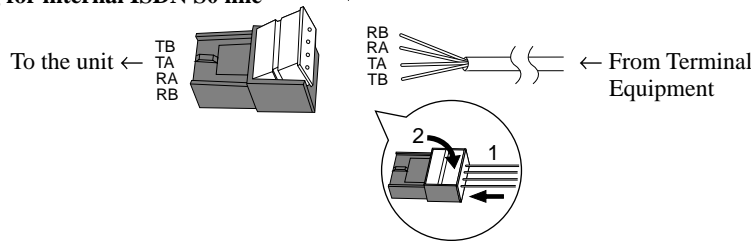

2. Insert the plug into an ISDN S0 port on the unit.

KX-TD280

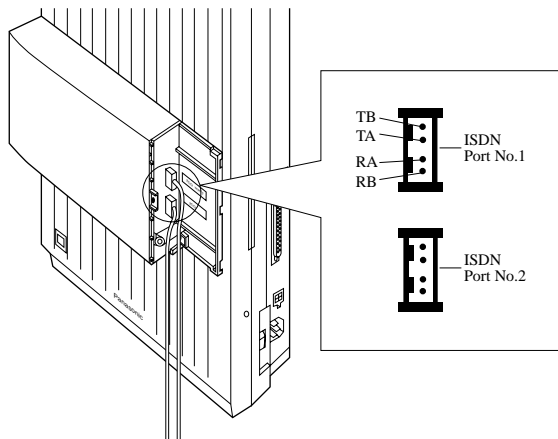

To ISDN equipment

KX-TD286

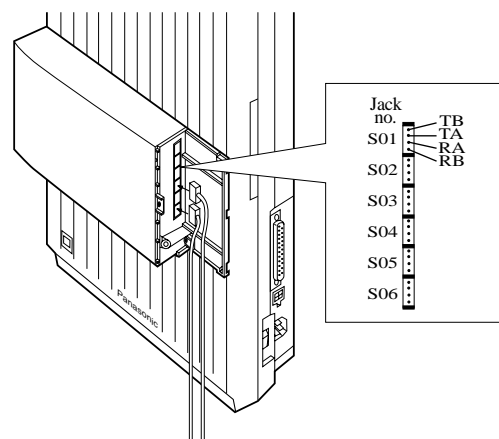

To ISDN equipment

3. Connect the lines between the ISDN board and the ISDN device.
4. Plug the AC power cord into the system and an AC outlet.
5. Programme [424] ISDN Port Type and other required programmes in System Programming.

6. Press the Reset Button with a pointed tool on the main unit.

Note

For installing the KX-TD280 or KX-TD286 to main unit, refer to the Section 3.2.2 Installing the Unit respectively.

Features Guide References

Integrated Services Digital Network (ISDN) Extension

Maximum cabling distance of S0 bus connection

The maximum length of the extension line cord that connects the main unit and the ISDN Terminal Equipment (TE) is shown below.

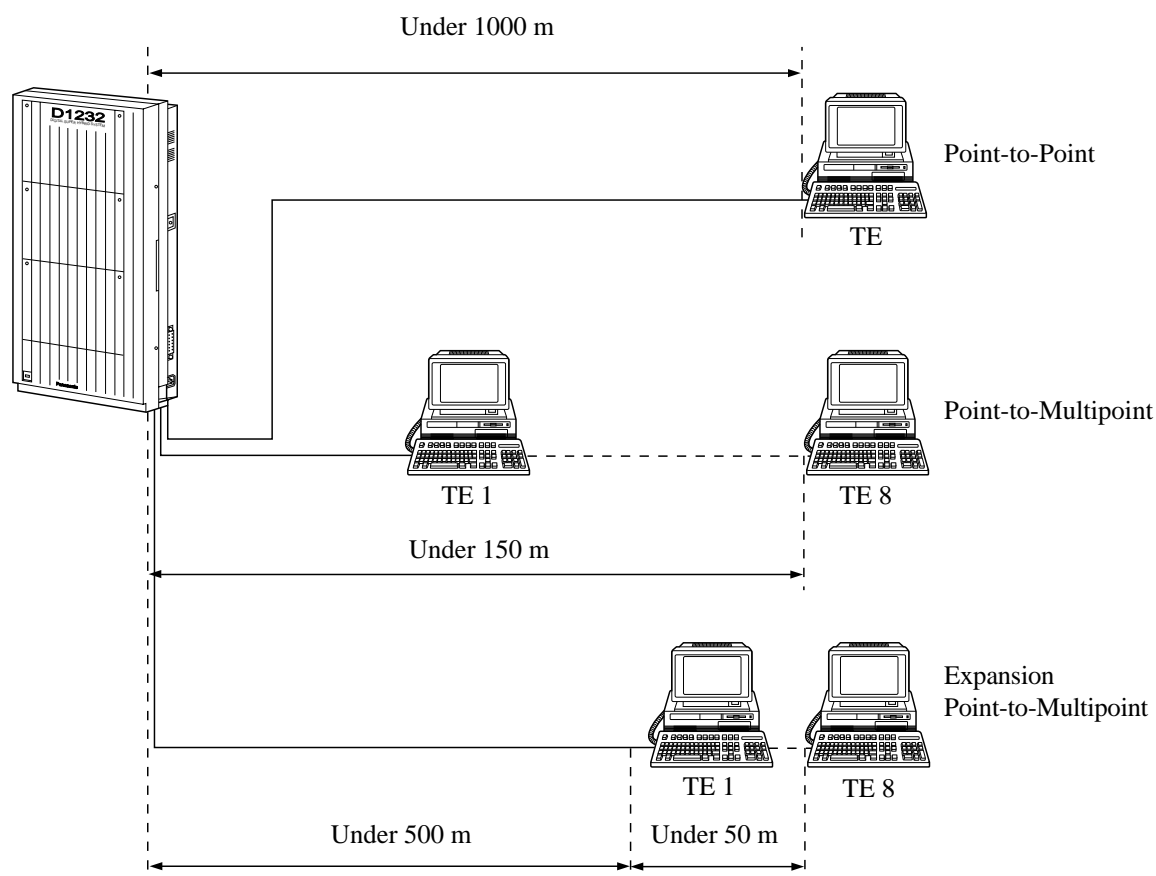

Wiring with Terminating Resistors (TR)

The ISDN S0 bus should be terminated with two 100 Ω terminating resistors (TR).

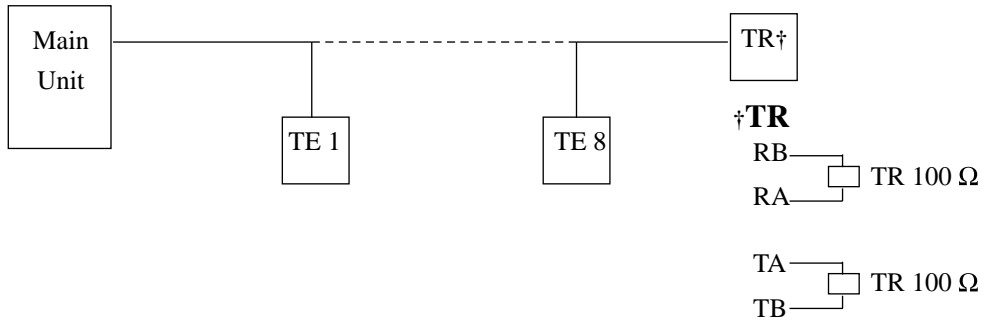

Power Supply for ISDN Terminal Equipment (TE)

The system does not provide a power supply to terminal equipment (TE). Depending on the type of TE's, the external power supply is required on ISDN S0 line to operate.

Section 4
E & M Installation

4.1 E & M (TIE) Line Service Outline

4.1.1 Overview

To use the E & M (TIE) Line Service, the following unit is required.

E & M (TIE) Line Unit (KX-TD184)

The unit supports up to four ports for E & M (TIE) Line Service.

One KX-TD184 can be connected to the KX-TD816 and KX-TD1232.

4.1.2 Specifications

Item	Description
E&M (TIE) Line Types	Type 5 only
Transmission	2-wire or 4-wire voice path (Programmable) (Note) Maximum cabling distance of the E&M line cord (twisted cable): 22 AWG: Under 9.6 km
Transmission levels	2-wire voice path: -3 db (transmit/receive) 4-wire voice path: -3 db normal (transmit/receive) Programmable (-6 db, -3 db, 0 db, +3 db)
Signalling	DTMF or Pulse
E lead	Battery: -48 VDC, 20 mA to ground (max.) Sensitivity: 5 mA or 2000 Ω to ground (max.) (min)
M lead	Available current: 30 mA (max.) Available voltage: ± 100 V (max.)

4.2 E & M (TIE) Line Installation

4.2.1 Location of the Unit

Precautions To protect the printed circuit boards (P-boards) from static electricity, do not touch parts on the P-boards in the main unit and on the optional unit.

KX-TD816

One E & M (TIE) Line Unit (KX-TD184) can be installed to either of the two expansion areas on the KX-TD816.

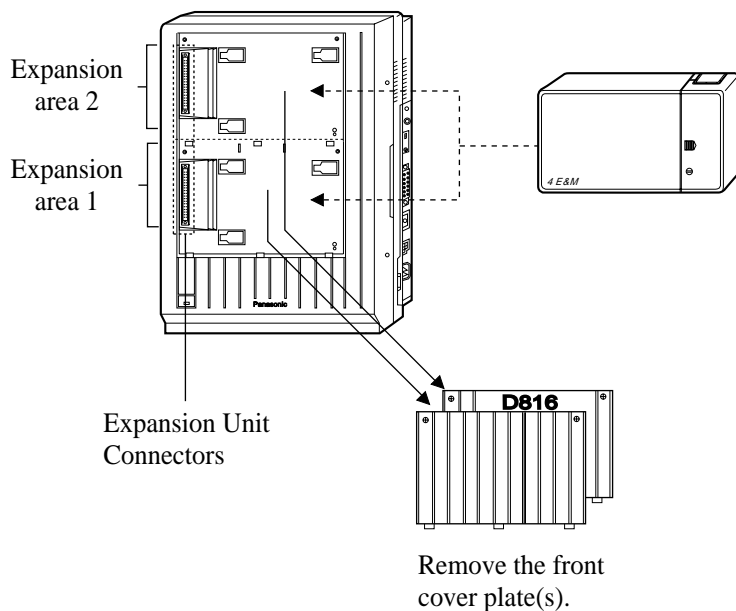

Note

- System Programming is required for expansion unit location.
<SYS PRG [109]>
 Default : Area 1 = 4-CO Line Unit
 Area 2 = 8-Station Line Unit
- For unit combination, refer to Section 1.4.2 Expansion Unit Combination.

KX-TD1232

One E & M (TIE) Line Unit (KX-TD184) can be installed to any expansion area on the KX-TD1232.

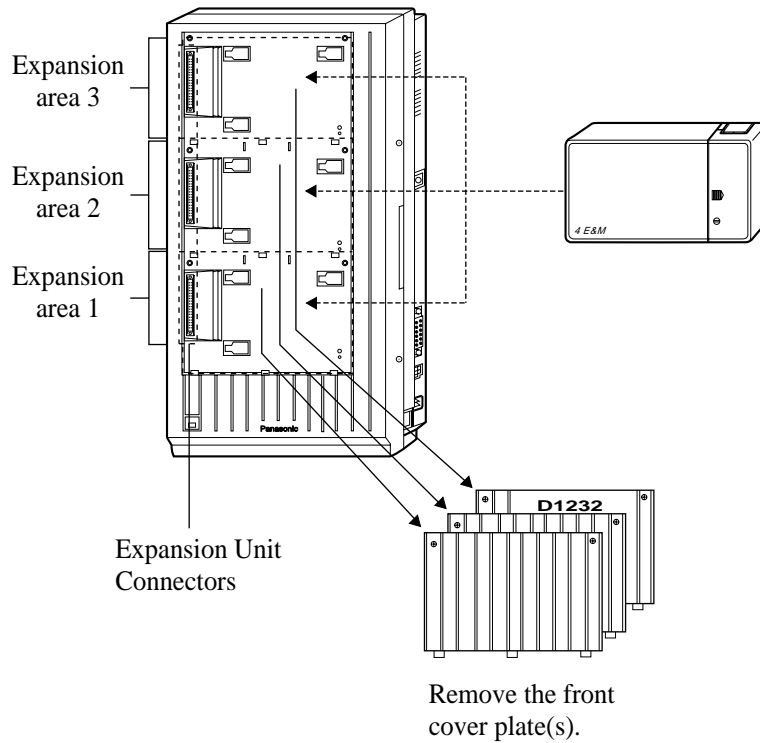
**Note**

- System Programming is required for expansion unit location.
<SYS PRG [109]>
Default : Area 1 = 4-CO Line Unit
Area 2 and 3 = 8-Station Line Unit
- For unit combination, refer to Section 1.4.2 Expansion Unit Combination.

4.2.2 Installing the Unit

Installing one unit to the system allows four E&M (TIE) lines to be connected to outside lines 05 through 08 for the KX-TD816, or outside lines 09 through 12 or 21 through 24 for the KX-TD1232.

The KX-TD1232 is illustrated as the main unit.

1. Loosen two screws on the cover plate. Insert fingers into the slits to remove the cover plate.

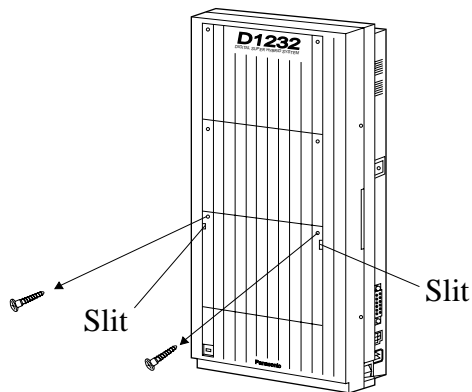

Note

Any of the cover plates can be removed, as needed.

2. Connect the cabinet cord to the connector in the main unit firmly.

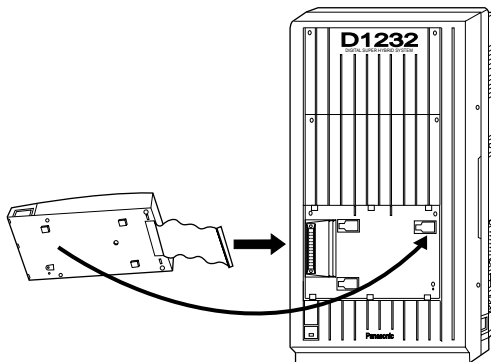

3. Hook the cabinet to the main unit and slide the cabinet to the left until it is secured.

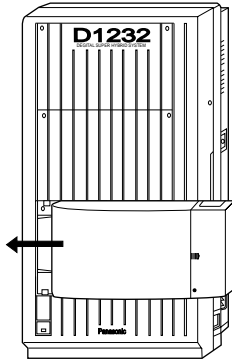

4. Loosen the outside screw and slide the cover to the right.

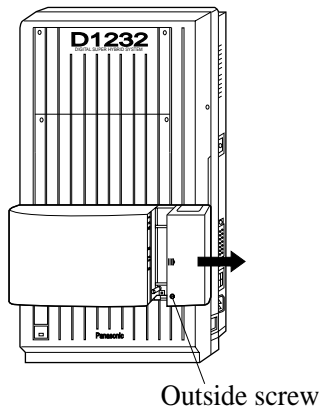

5. Secure the inside screw (included) to fix the cabinet to the main unit.

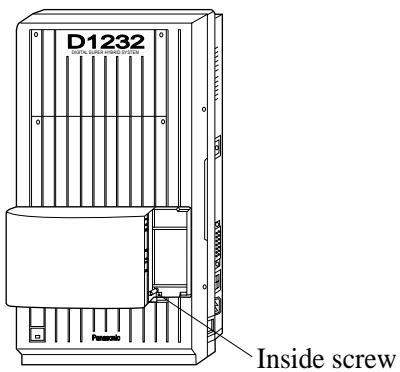

Note

Be sure to fix the inside screw to the main unit, or the unit may not work properly.

6. Insert the Amphenol Connector into the jack.

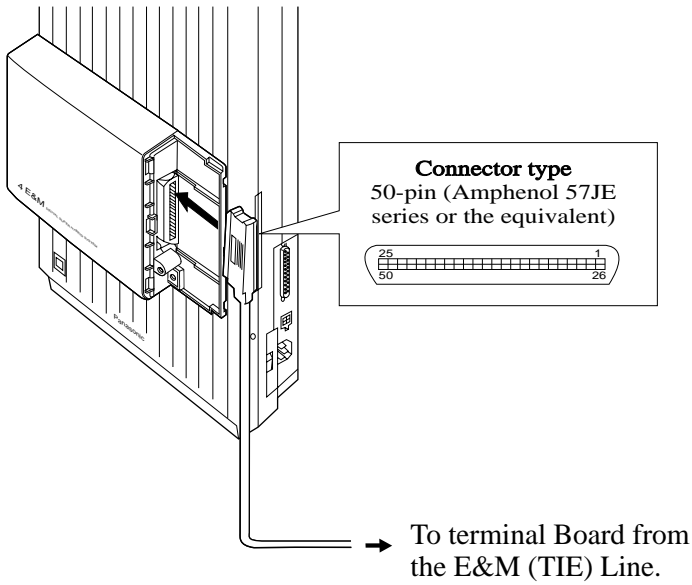

Note

- To fix the connector, refer to Section 2.4.5 Installing Expansion Unit, Amphenol 57JE Type (screw-attach-type 50-pin connector) Connection for KX-TD170.
 - For jack connection, please see "Pin Number Chart" in Section 4.2.3 E&M (TIE) Line Connection.
7. Tie all of the cords into a bundle. If other cords are exposed in the upper cabinets, tie them also.
 8. Close the cabinet cover and secure the outside screw.
 9. Cover the cords with the cord holder (included).

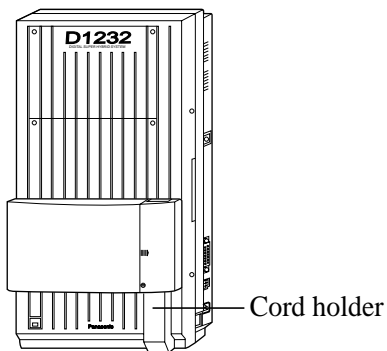

10. Fix the cords to the wall as shown so that the front cover can be opened.

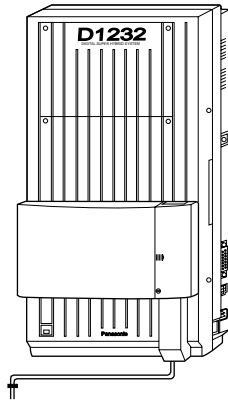

Note

If two or three expansion units are installed, cut the cabinet covers on the lower cabinets to allow the cords from the upper cabinet to go down through the cabinet covers. To protect the cords, smooth the cut edges.

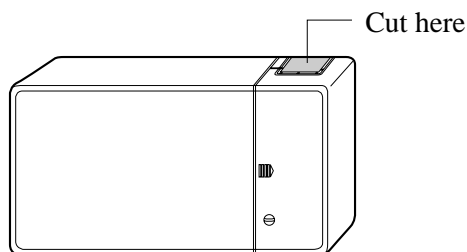

Programming References

[109] Expansion Unit Type

4.2.3 E&M (TIE) Line Connection

Pin Number Chart (E&M Line)

Connect Pin	Cable Color	Clip No.	Number of Dots	E&M Line	
1	ORN-RED	1	1	NO.1	T } 2-wire or 4-wire - send
26	ORN-BLK	2	1		R } 2-wire or 4-wire - send
2	YEL-RED	3	1		T1 } 4-wire - receive
27	YEL-BLK	4	1		R1 } 4-wire - receive
3	GRY-RED	5	1		E Lead
28	GRY-BLK	6	1		SG Lead
4	WHY-RED	7	1		SB Lead
29	WHY-BLK	8	1		M1 Lead
5	ORN-RED	9	1		SG0
30	ORN-BLK	10	1		M Lead only for Type 5
6	YEL-RED	11	2	NO.2	T } 2-wire or 4-wire - send
31	YEL-BLK	12	2		R } 2-wire or 4-wire - send
7	GRY-RED	13	2		T1 } 4-wire - receive
32	GRY-BLK	14	2		R1 } 4-wire - receive
8	WHY-RED	15	2		E Lead
33	WHY-BLK	16	2		SG Lead
9	ORN-RED	17	2		SB Lead
34	ORN-BLK	18	2		M1 Lead
10	YEL-RED	19	2		SG0
35	YEL-BLK	20	2		M Lead only for Type 5
11	GRY-RED	21	3	NO.3	T } 2-wire or 4-wire - send
36	GRY-BLK	22	3		R } 2-wire or 4-wire - send
12	WHY-RED	23	3		T1 } 4-wire - receive
37	WHY-BLK	24	3		R1 } 4-wire - receive
13	ORN-RED	25	3		E Lead
38	ORN-BLK	26	3		SG Lead
14	YEL-RED	27	3		SB Lead
39	YEL-BLK	28	3		M1 Lead
15	GRY-RED	29	3		SG0
40	GRY-BLK	30	3		M Lead only for Type 5
16	WHY-RED	31	4	NO.4	T } 2-wire or 4-wire - send
41	WHY-BLK	32	4		R } 2-wire or 4-wire - send
17	ORN-RED	33	4		T1 } 4-wire - receive
42	ORN-BLK	34	4		R1 } 4-wire - receive
18	YEL-RED	35	4		E Lead
43	YEL-BLK	36	4		SG Lead
19	GRY-RED	37	4		SB Lead
44	GRY-BLK	38	4		M1 Lead
20	WHY-RED	39	4		SG0
45	WHY-BLK	40	4		M Lead only for Type 5

Note

21-25, 46-50: Cannot be connected

Cable Pins to be Connected (E&M Line)

- E&M Line Wiring

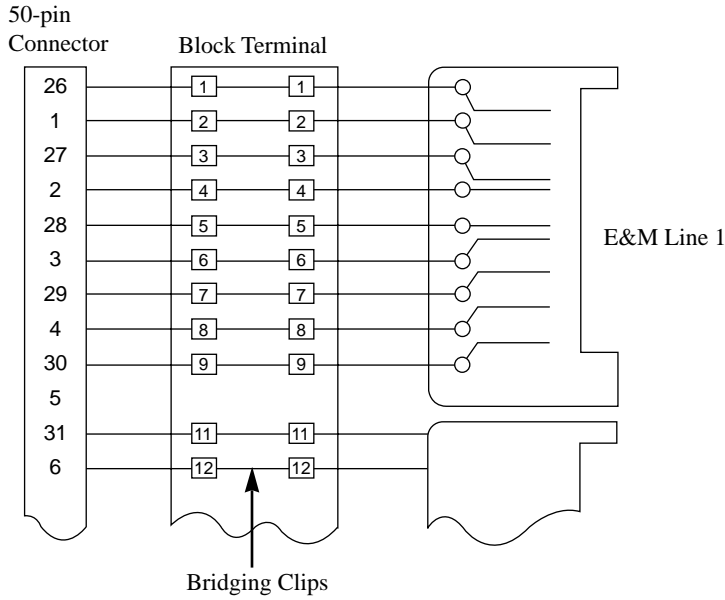

Connecting to another KX-TD816/KX-TD1232 system (KX-TD184)

1. 2-wire voice path

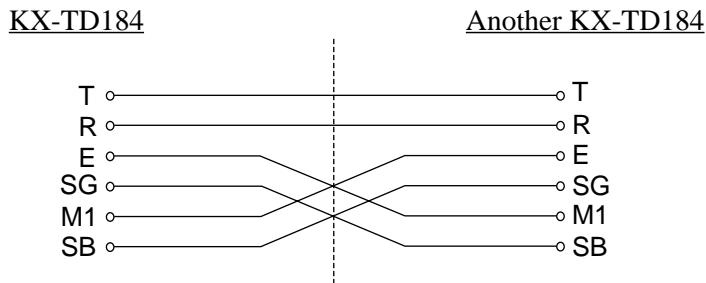

2. 4-wire voice path

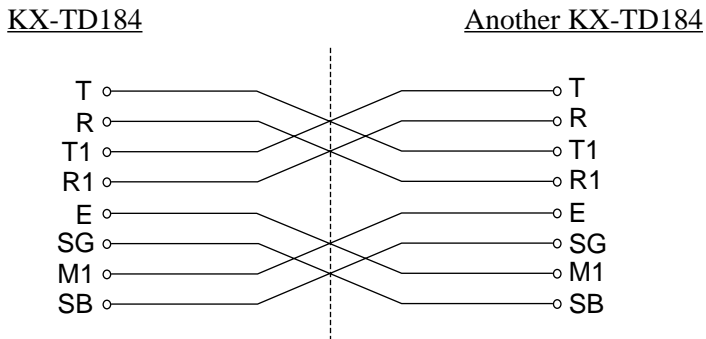

Connecting to the E&M Central Office

1. 2-wire voice path

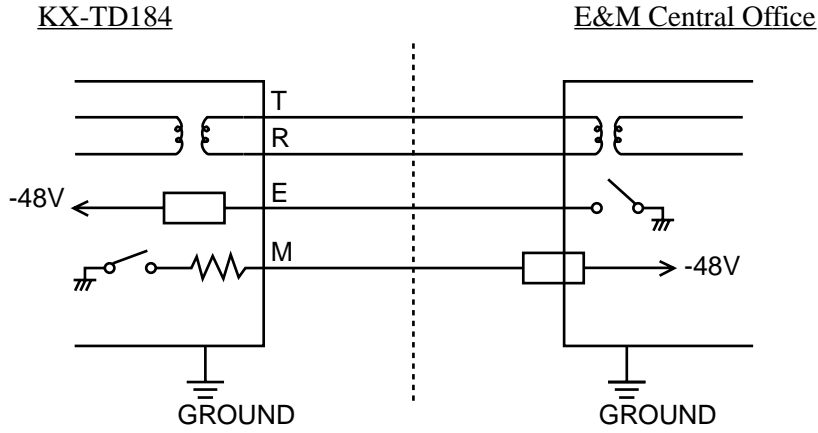

2. 4-wire voice path

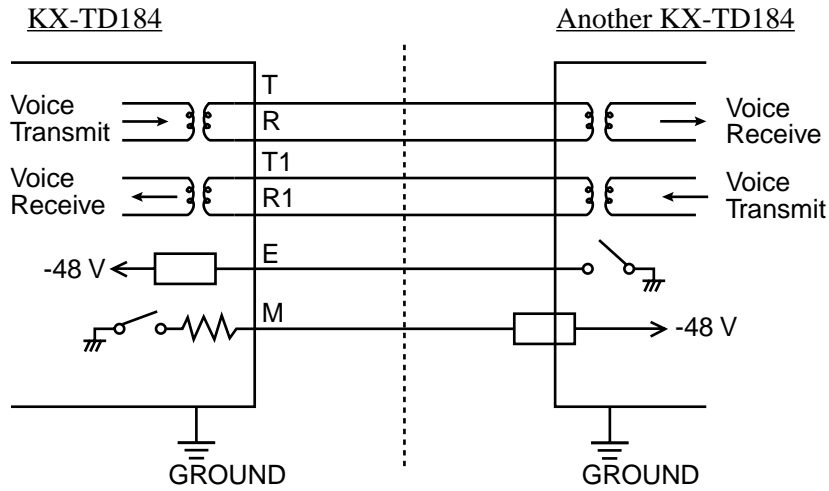

E&M Sequences

You can choose one of the following E&M sequences. <SYS PRG [129]>

1. Continuous E&M

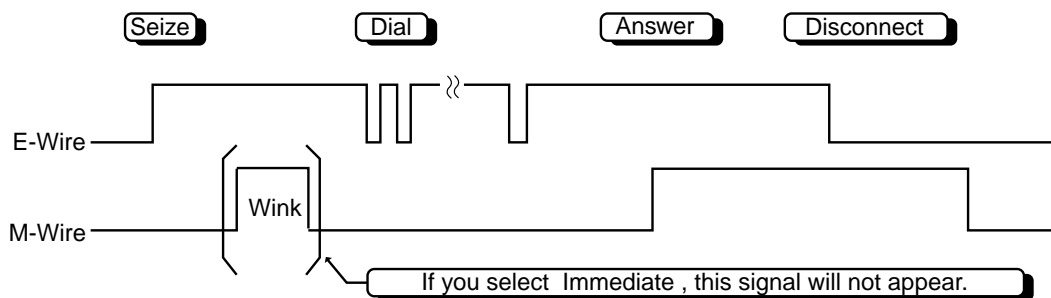

2. Pulsed E&M with Answer signal

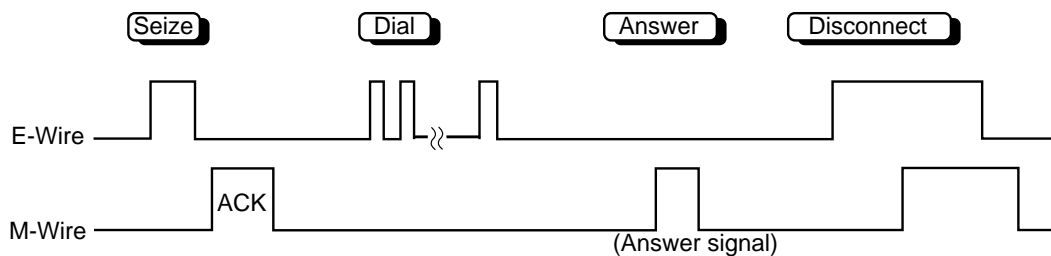

* If you select this sequence, then you must select "Wink" as the start type.

3. Pulsed E&M without Answer signal

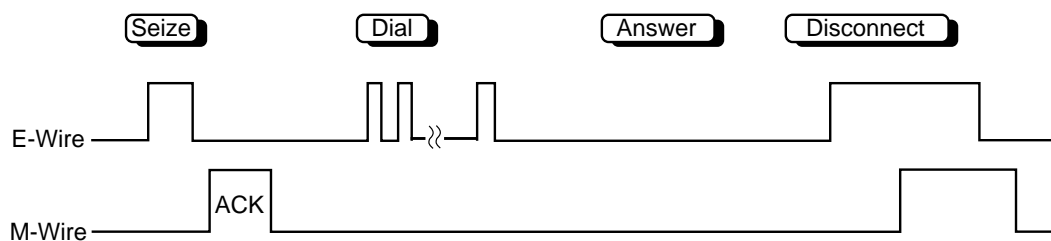

* If you select this sequence, then you must select "Wink" as the start type.

Section 5
DECT Installation

5.1 Wireless System Outline

5.1.1 Overview

To connect the wireless system, the following equipment is required.

Cell Station Interface Unit (KX-TD144)

One KX-TD144 supports up to two Cell Stations (KX-TD142) and four wired extensions. One KX-TD144 can be connected to the KX-TD816 and up to two KX-TD144s can be installed to the master KX-TD1232.

Cell Station Interface Unit (KX-TD146)

One KX-TD146 supports up to six Cell Stations (KX-TD142).

One KX-TD146 can be connected to the KX-TD816 and up to two KX-TD146s can be connected to the master KX-TD1232.

CS: Cell Station (KX-TD142)

This unit determines the range of the supporting PSs. Up to four calls can be made at the same time in one range.

PS: DECT Portable Station (KX-TD7500)

Up to 16 PSs in the KX-TD816 system and up to 64 PSs in the KX-TD1232 system can be used as extensions. For more details about the PS, please refer to the User Manual.

5.1.2 RF Specifications

Item	Description
Radio Access Method	Multi Carrier TDMA-TDD
Multiplex	12
Carrier Frequency Interval	1728 kHz
Transmission Speed	1152 kbps
Frame Structure	10 ms / frame (T×12 slots + R×12 slots)
Modulation Scheme	GFSK
	Roll-off factor = 0.5 50% roll-off in the transmitter
Data Coding for Modulator	Differential Coding
Voice CODEC	32 kbps ADPCM (CCITT G.721)
Transmission Output	Max. 250 mW

5.1.3 Procedure Flow Chart

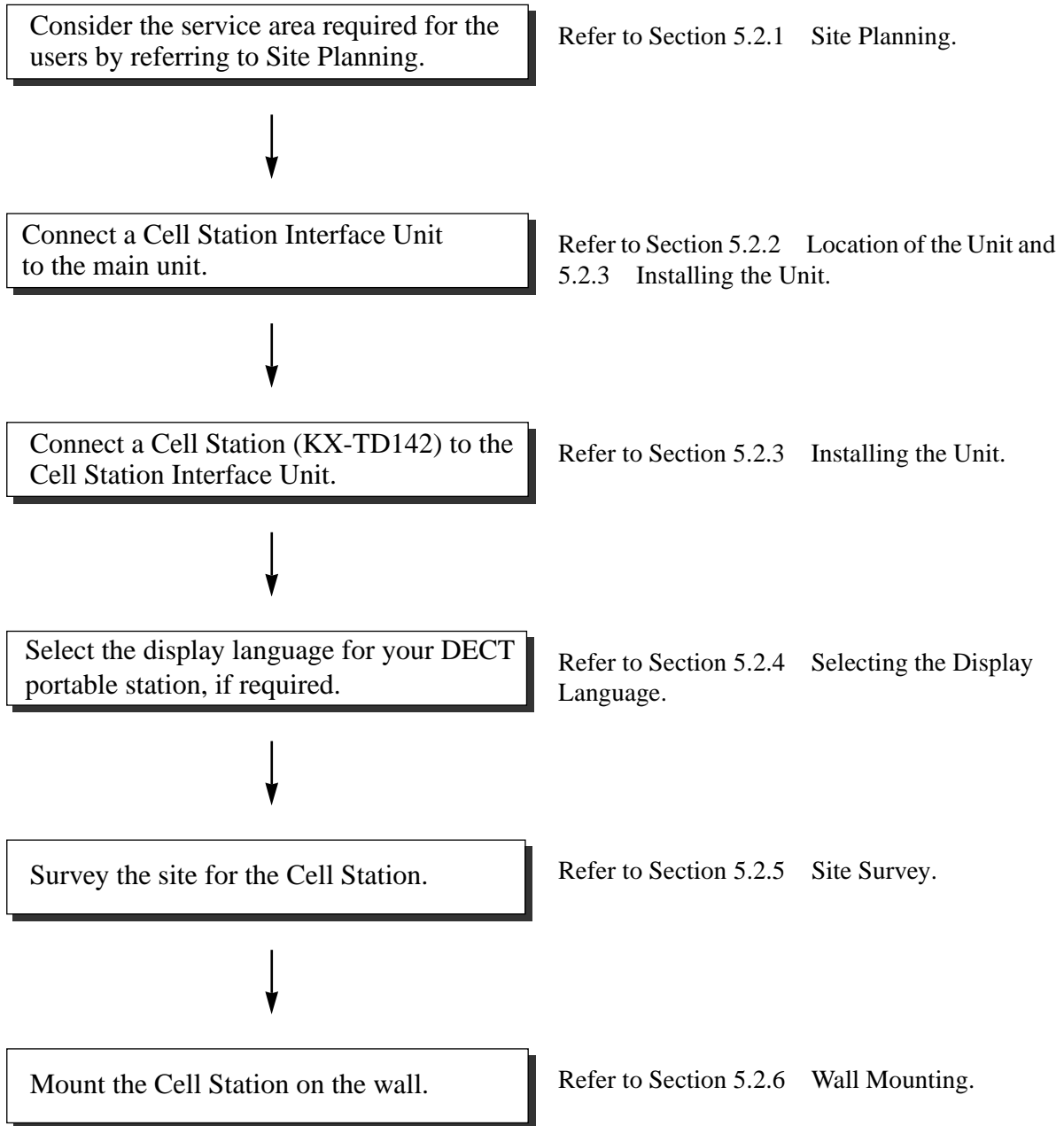

Note

- The master CS number must be assigned before using a Cell Station.
<SYS PRG [680]>

5.2 Wireless System Installation

5.2.1 Site Planning

Choosing the best site for the Cell Station (KX-TD142) requires careful planning and testing of essential areas. The best location may not always be convenient for installation. Please read the following information before you install the unit.

Characteristics of Radio Waves

The transmission of radio waves and the operating range depend on the structure and materials of the building.

Office equipment, such as computers and fax machines, can interfere with radio waves.

Such equipment may create noise or interfere with the performance of the portable station.

The illustration below shows the special transmitting patterns of radio waves.

1. Radio waves are reflected by objects such as those made of metal.
2. Radio waves are diffracted by objects such as metallic columns.
3. Radio waves penetrate objects such as those made of glass.

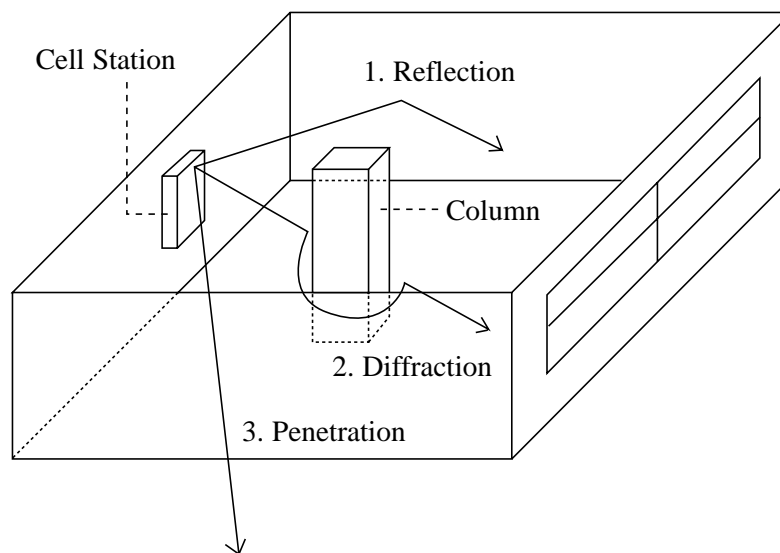

The Relationship between Radio Waves and Building Structure and Materials

- The transmitting range is affected more by the building materials and thickness of the material than the number of obstacles.
- Radio waves tend to be reflected or diffracted by conductive objects and rarely penetrate them.
- Radio waves tend to penetrate insulated objects and are rarely reflected by them.
- Radio waves penetrate thin objects more than thick objects.

- The table below shows the transmission tendency of radio waves when they reach objects made from various materials.

Object	Material	Transmission Tendency
Wall	Concrete	The thicker they are, the less radio waves penetrate them.
	Ferroconcrete	Radio waves can penetrate them, but the more iron there is, the more radio waves are reflected.
Window	Glass	Radio waves usually penetrate them.
	Glass with wire nets	Radio waves can penetrate them, but tend to be reflected.
	Glass covered with heat-resistant film	Radio waves are weakened considerably when they penetrate windows.
Floor	Ferroconcrete	Radio waves can penetrate them, but the more iron there is, the more radio waves are reflected.
Partition	Steel	Radio waves are reflected and rarely penetrate them.
	Plywood, Glass	Radio waves usually penetrate them.
Column	Ferroconcrete	Radio waves can penetrate them, but the more iron there is, the more radio waves tend to be reflected or diffracted.
	Metal	Radio waves tend to be reflected or diffracted.
Cabinet	Steel	Radio waves are usually reflected or diffracted, and rarely penetrate them.
	Wood	Radio waves can penetrate them, but they are weakened.

Installation Preparation

1. Prepare a drawing of the building where you want to install the Cell Station (CS).
(A drawing which shows the size or main structural material of the wall, partition wall or ceiling is preferable.)
2. Consider the service area required for the users.
3. Examine the service area on the drawing.
 - a) Make a circle around the installable area by determining the radio transmission range (inside: 25 m – 50 m, outside: 70 m – 100 m). Note that a CS cannot be installed outside a building.
 - b) If more than one CS is required, the radio transmission ranges should overlap. The overlapping range should be at least 5 to 10 meters.

<Basic location>

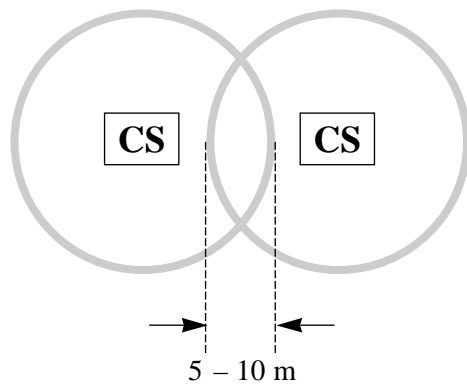

<Location example for a building which has an object in the centre.>

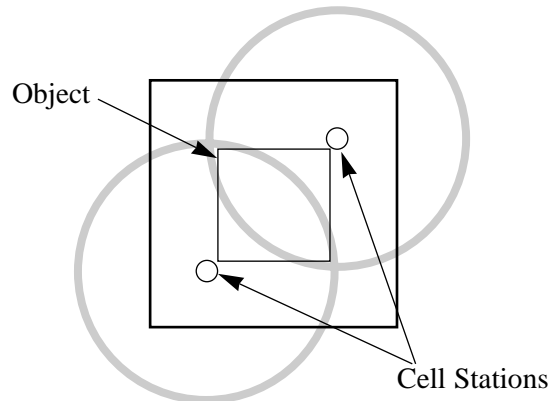

Precautions

- The Cell Station should be kept free of dust, moisture, high temperature (more than 40 °C), low temperature (less than 5 °C), vibration, and should not be exposed to direct sunlight.
- Keep distance between the equipment listed below in order to prevent noise, interference or the disconnection of a conversation.

Equipment	Distance
Cell Station and office equipment such as a computer, telex, fax, etc., or microwaves.	more than 1.8 m
Cell Station and portable station	more than 1 m
Two portable stations	more than 0.5 m
Portable station and proprietary wired telephone	more than 1 m
The system and Cell Station	more than 2 m

Note

- In Cell Station overlap areas, if the signal from one Cell Station becomes weak, the portable station will start Call handover to the next Cell Station. However if there is no free channel for call handover, the portable station will remain with its current Cell Station until out of range and the call is lost.
- Too many Cell Station in a small area can cause problems due to conflicts over which signal channels each Cell Station can use. Ideally Cell Stations should be a minimum of 25 to 40 m apart.

5.2.2 Location of the Unit

KX-TD816 with the KX-TD144

One Cell Station Interface Unit (KX-TD144) can be connected to either of the two expansion areas. Up to two Cell Stations (KX-TD142) can be connected to the KX-TD144.

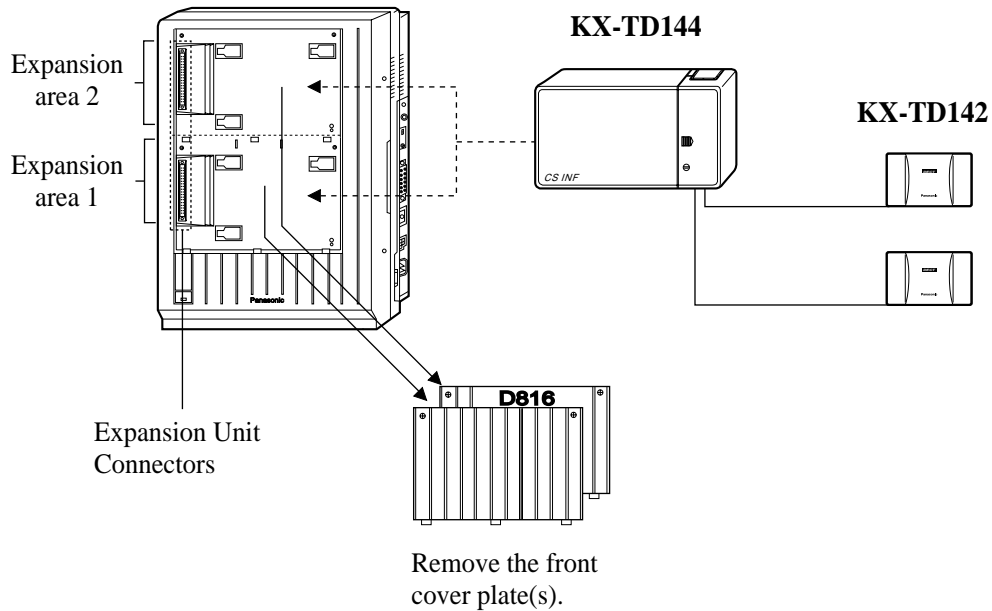

Note

- System Programming is required for expansion unit location.
 <SYS PRG [109]>
Default : Area 1 = 4-CO Line Unit
 Area 2 = 8-Station Line Unit
- For unit combination, refer to Section 1.4.2 Expansion Unit Combination.

KX-TD1232 with the KX-TD144

Up to two Cell Station Interface Units (KX-TD144) can be connected to any of the three expansion areas. Up to two Cell Stations (KX-TD142) can be connected to the KX-TD144.

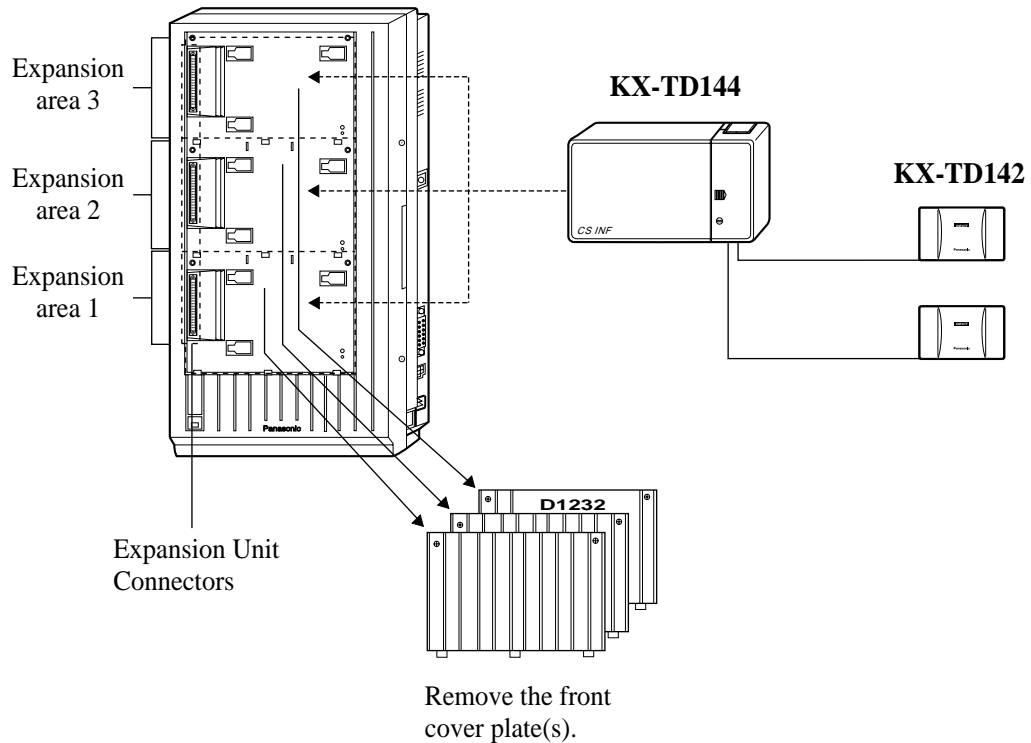

Note

- System Programming is required for expansion unit location.
<SYS PRG [109]>
Default : Area 1 = 4-CO Line Unit
 Areas 2 and 3 = 8-Station Line Unit
- KX-TD144 can only be connected to the Master System.
- For unit combination, refer to Section 1.4.2 Expansion Unit Combination.

KX-TD816 with the KX-TD146

One Cell Station Interface Unit (KX-TD146) can be connected to either of the two expansion areas. Up to six Cell Stations (KX-TD142) can be connected to the KX-TD146.

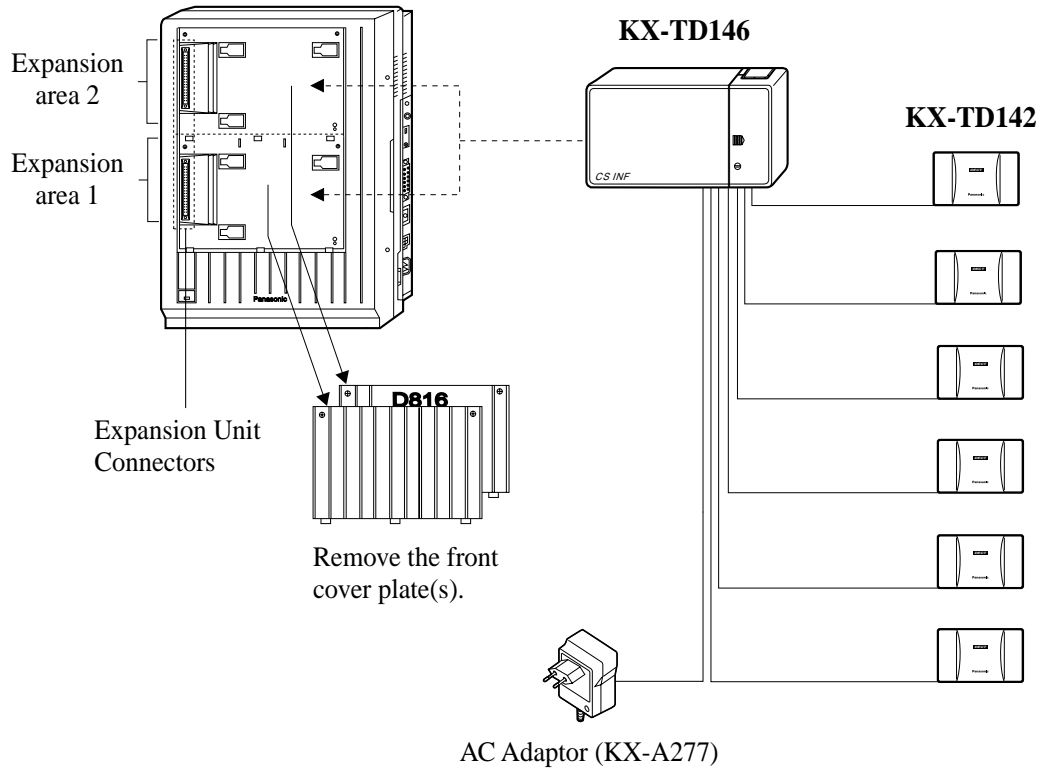

Note

- System Programming is required for expansion unit location.
 <SYS PRG [109]>
 Default : Area 1 = 4-CO Line Unit
 Area 2 = 8-Station Line Unit
- The AC adaptor (KX-A277) is necessary.
- For unit combination, refer to Section 1.4.2 Expansion Unit Combination.

KX-TD1232 with the KX-TD146

Up to two Cell Station Interface Units (KX-TD146) can be connected to any of the three expansion areas. Up to six Cell Stations (KX-TD142) can be connected to the KX-TD146.

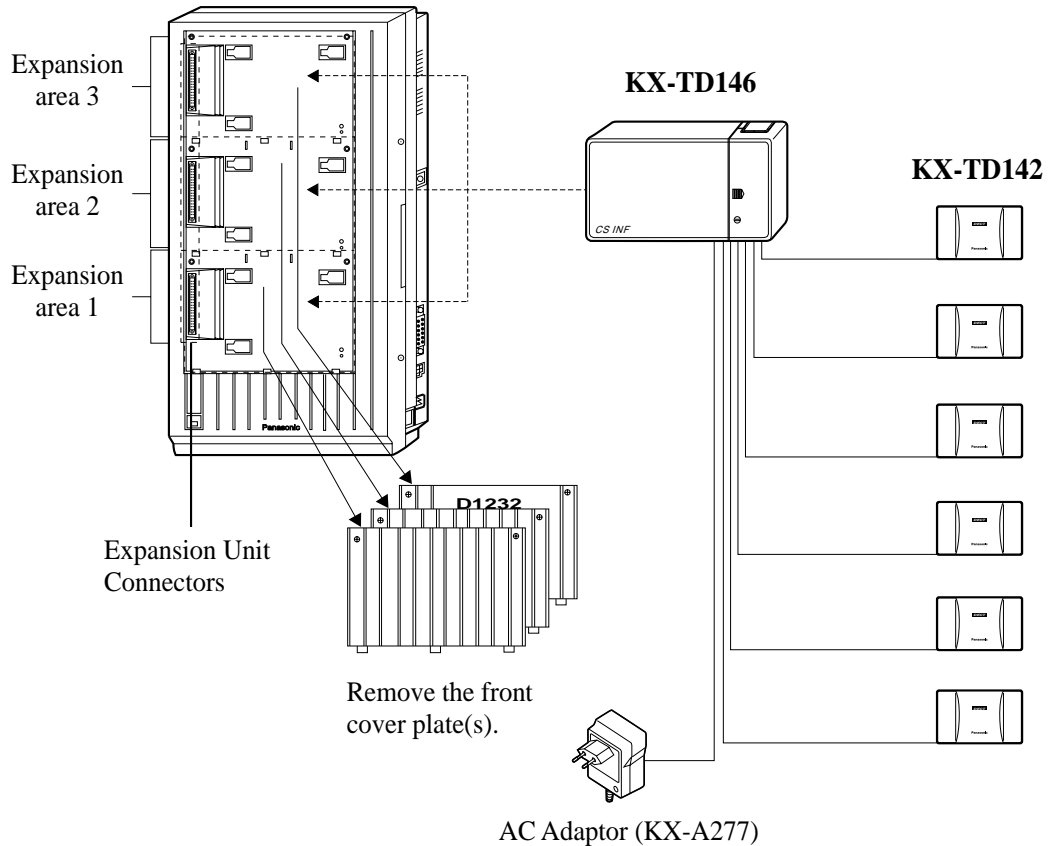

Note

- System Programming is required for expansion unit location.
<SYS PRG [109]>
Default : Area 1 = 4-CO Line Unit
 Areas 2 and 3 = 8-Station Line Unit
- An AC adapter (KX-A277) is necessary.
- KX-TD146 can only be installed to the Master system.
- For unit combination, refer to Section 1.4.2 Expansion Unit Combination.

5.2.3 Installing the Unit

The following procedures can be used to connect Cell Station Interface Unit to the main unit, and then the Cell Station to the Cell Station Interface Unit.

The KX-TD1232 is illustrated as the main unit.

1. Loosen the two screws on the cover plate. Insert your fingers into the slits to remove the cover plate(s).

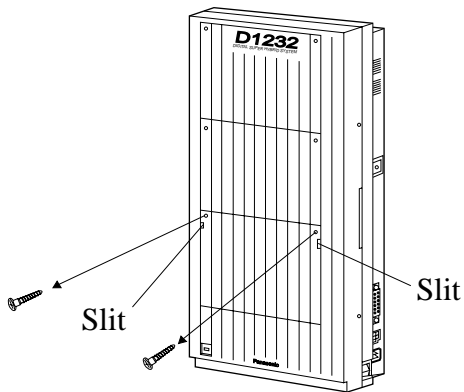

Note

Any of the cover plates can be removed as required.

2. Connect the cabinet cord of the Cell Station Interface Unit to the connector in the main unit firmly.

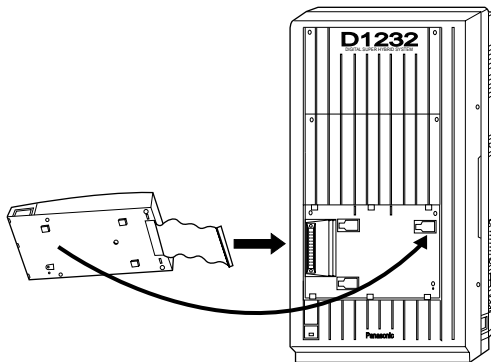

- Hook the cabinet on the main unit and slide the cabinet to the left until it is secured.

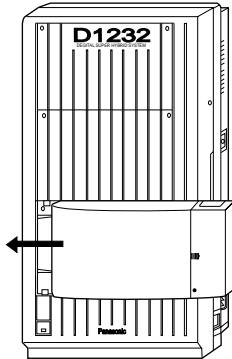

- Loosen the outside screw and slide the cover to the right.

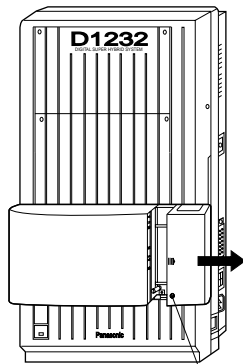

Outside screw

- Secure the inside screw firmly to fix the cabinet to the main unit.

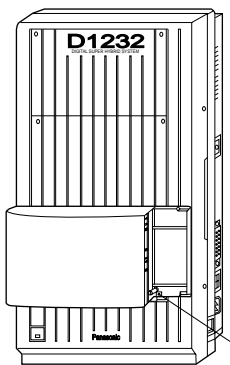

Inside screw

Note

Be sure to fix the inside screw to the main unit, or the unit may not work properly.

6. Wireless Extension Connection

Use a Cell Station Cord (4-conductor wiring - included) and 4-pin plug (included) to connect the cell station line. There are 2 plugs for the KX-TD144 and 6 plugs for the KX-TD146 to connect the Cell Stations.

Maximum length of the cable: AWG 24 (0.6 mm in diameter): Under 1 km

- a) Insert the wires of the 4-conductor wiring cord into the holes in the plug to connect pins "D1", "D2", "V1" and "V2".

D1: Data 1 V1: Voltage +
 D2: Data 2 V2: Voltage -

Press the transparent part into the black part.

Insert the other end of the wires into the modular plug.

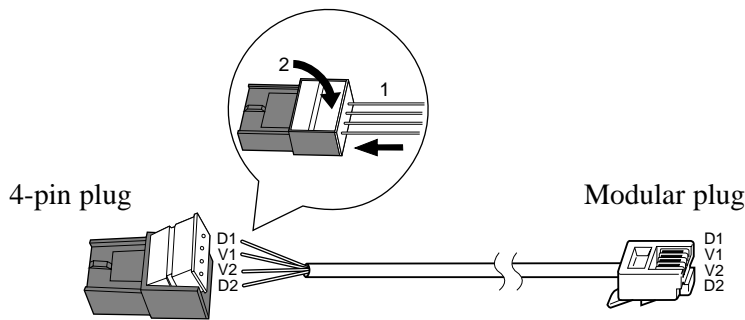

Note

Do not peel off the wire coating. Insert the wires all the way.

- b) Insert the 4-pin plug into a cell station jack on the unit, and attach the ferrite core (included) to the plug cord.

KX-TD144

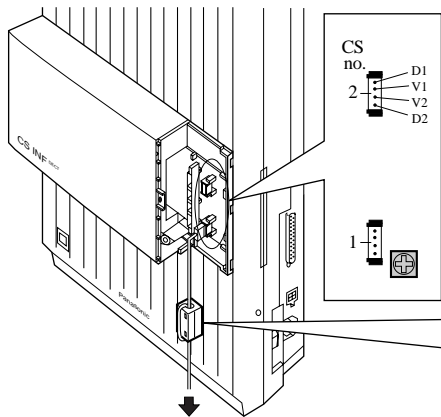

To the Cell Station

- ⊕ Connect the ground terminal to ground.
Note: If other expansion units are installed, the frame ground connection is required for only one unit.

KX-TD146

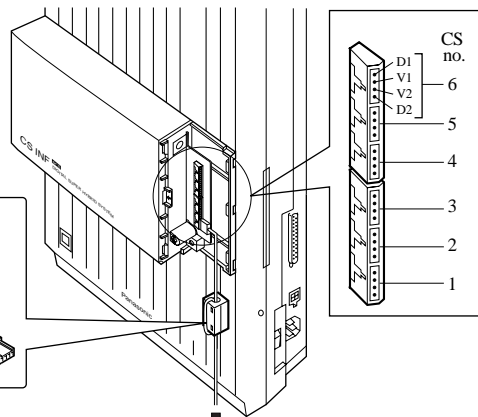

To the Cell Station

Ferrite Core

Roll the cord once around the ferrite core and close the core.

Note: Put it in the cabinet when closing the cabinet cover.

- c) Insert the modular plug into the Cell Station, and attach the ferrite core (included) to the plug cord.

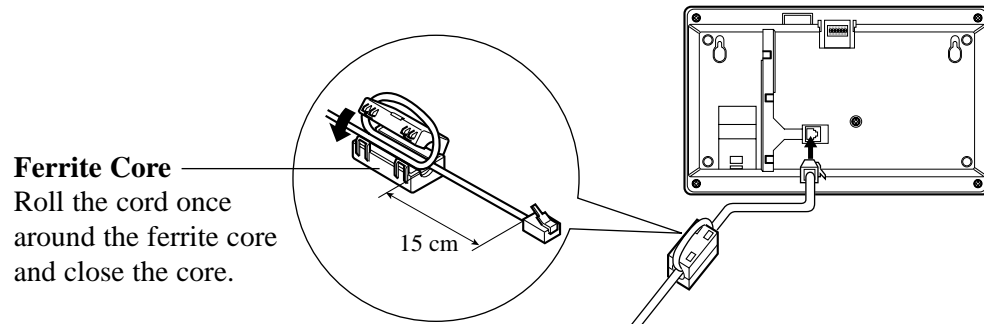

- d) Survey the site for the Cell Station by testing the radio signal. Refer to the Section 5.2.5 Site Survey.

Note

- System Programming is required to assign an extension number to each portable station. <SYS PRG [650], [671]>
- For the KX-TD146, an AC adapter (KX-A277) is necessary. The same AC outlet should be used for the main PBX unit and a Cell Station Interface Unit.

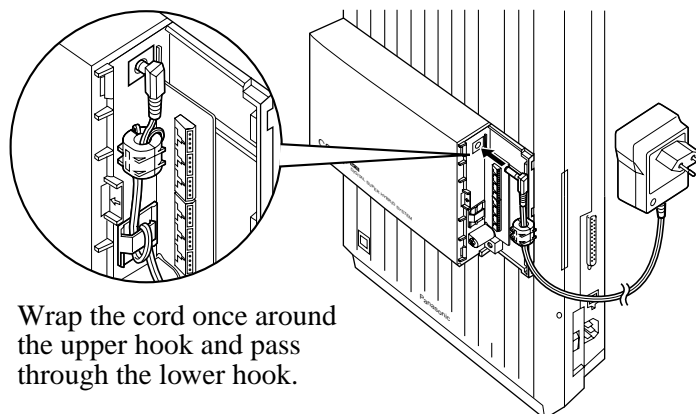

7. Wired Extension Connection (KX-TD144 only)

A Cell Station Interface Unit can support four wired extensions as well as wireless extensions. Use 4-pin plugs to connect the wired extensions.

- a) Insert the required telephone wires into the holes in the plug. Press the transparent part into the black part.

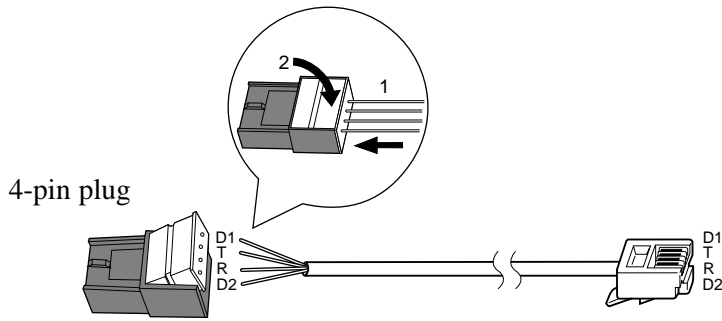

Note

Do not peel off the wire coating. Insert the wires all the way.

- b) Insert the plug into a jack on the unit.

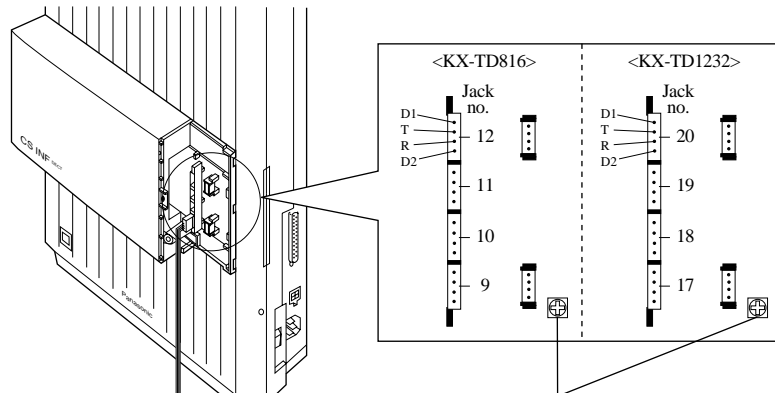

Connect the ground terminal to ground.

Note: If other expansion units are installed, the frame ground connection is required for only one unit.

Note

Actual jack numbers for the KX-TD1232 depend on the type and location of units connected to the system.

- 8. Tie all of the cords into a bundle. If other cords are exposed in the upper cabinet, tie them also.
- 9. Close the cabinet cover and secure the outside screw.

10. Cover the cords with the cord holder (included).

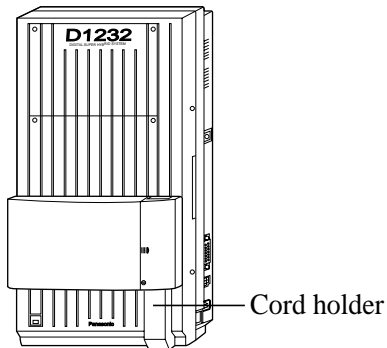

11. Fix the cords to the wall as shown so that the front cover can be opened.

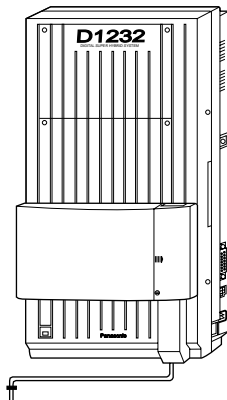

Note

If two expansion units are installed, cut the cabinet cover(s) on the lower cabinet(s) to allow the cords from the upper cabinet to go down through the cabinet cover(s). To protect the cords, smooth any cut edges.

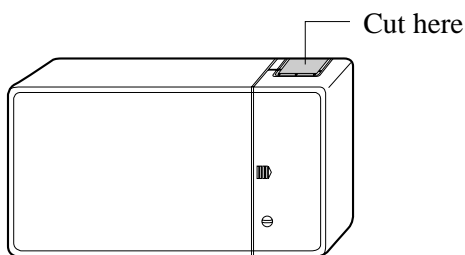

SAFETY CAUTION for KX-TD144

The small cover which provides access to connectors CN402, CN403, CN404 and CN405 shall not have its cable knock-out section removed, unless another expansion unit is mounted above which would prevent finger access via the cable knock-out opening. This safety requirement is necessary to protect users from network voltages.

Programming Guide References













- [650] PS Registration
- [653] PS Extension Name Set
- [671] PS Extension Number Set
- [672] PS Password Set
- [680] Cell Station Number Assignment for Master CS

Features Guide References

- Digital Wireless Connection

5.2.4 Selecting the Display Language

The default setting of the PS displaying language is "AUTO (English)". If Spanish display is required, follow the procedure below.

1. Press  (Function).
Display: KEY
2. Press  (Book) 2 times.
 - You can also search by pressing  (Next) or  (Previous).
 Display: PROGRAMMING
3. Press  (OK).
Display: PS-PROGRAM
4. Press  (OK).
Display: BACKLIGHT
= ON
5. Press  (Next) or  (Previous) repeatedly until the display for the Language Selection appears.
Display: LANGUAGE
= AUTO
6. Press  (Book) until the desired selection is displayed.
 - You can also search by pressing  (Next) or  (Previous).
 Display example: LANGUAGE
= SPANISH
7. Press  (OK).
Display example: BLOQ AGENDA
= NO
8. To exit the PS Programming mode, press  (Cancel).

Note

- Moreover, you can select French, Italian, Dutch or German display.
- If you are going to assign the PS to the Digital Super Hybrid System while the default setting is still "AUTO", the displaying language will depend on the setting of the system.
- During the site survey, only English display is supported regardless of the setting.

5.2.5 Site Survey

Site Survey Specification

The KX-TD7500 portable station has Radio Signal Test Mode which monitors the state of link as one of the means to determine the site planning for the KX-TD142. In the mode, the frame loss and signal strength of a synchronous slot, and the signal strength of the other slots can be measured when the portable station is linking with the KX-TD142.

Flow Chart of the Site Survey

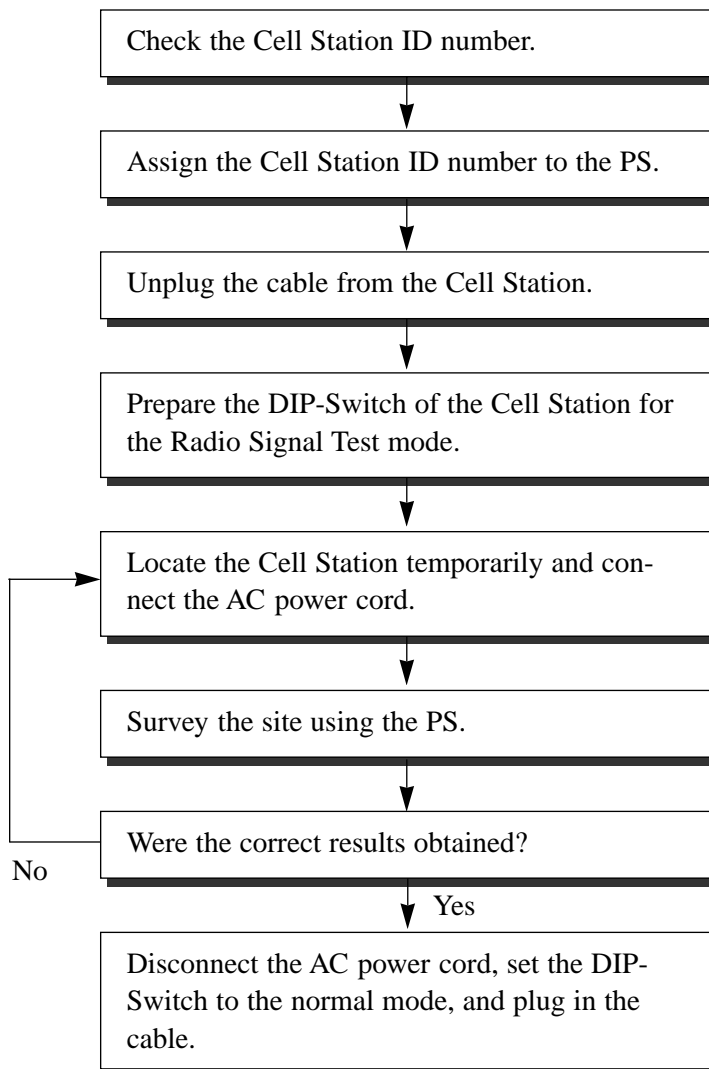

Checking the Cell Station ID Number

Use a personal computer to check the Cell Station (CS) ID number.
File: E1232B2.EXE

Main Menu Display

Main Menu	Off-line	Empty
<p>Panasonic</p> <p>Digital Super Hybrid System (DECT)</p> <p>Operating & Maintenance Tool Ver4.XXB2</p> <p>(C) COPYRIGHT 1997 KYUSHU MATSUSHITA ELECTRIC CO.,LTD.</p>		
<p>1.System Data Programming (BATCH)</p> <p>2.System Data Programming (INTERACTIVE)</p> <p>3.Disk File Management</p> <p>4.DSHS Management</p> <p>5.DSHS Connect/Disconnect</p> <p>6.Quit</p> <p>Select the number: []</p>		
<p>Enter the number, and hit ENTER key</p>		
1	2	3
4	HELP	5
6	7	8

Input Format

1. In the Main Menu Display

Enter **2** and press the **ENTER** key to select "System Data Programming (INTERACTIVE)".

2. In the System Data Programming Main Menu Display

Enter **2** and press the **ENTER** key to select "Station".

3. In the Station Menu Display

Enter **21** and press the **ENTER** key to select "CS Information".
The CS Information Display appears as shown on the next page.

CS Information Display

CS Information				On-line (RS-232C)			Empty	
CS No.	CS-ID			Large Info.	Small Info.	ROM Version	Diag. Code	Obst. Code
01	0000	0000	0000	FALUT	FALUT	0000	00	02
02	0000	0000	0000	FALUT	FALUT	0000	00	02
03	0080	1230	1260	INS	INS	0131	00	03
04	0080	1230	0360	FALUT	INIWAI	0131	00	03
05	0000	0000	0000	FALUT	FALUT	0000	00	02
06	0000	0000	0000	FALUT	FALUT	0000	00	02
07	0000	0000	0000	OUS	FALUT	0000	00	00
08	0000	0000	0000	OUS	FALUT	0000	00	00
09	0000	0000	0000	OUS	FALUT	0000	00	00
10	0000	0000	0000	OUS	FALUT	0000	00	00
11	0000	0000	0000	OUS	FALUT	0000	00	00
12	0000	0000	0000	OUS	FALUT	0000	00	00
13	0000	0000	0000	OUS	FALUT	0000	00	00
14	0000	0000	0000	OUS	FALUT	0000	00	00
15	0000	0000	0000	OUS	FALUT	0000	00	00
16	0000	0000	0000	OUS	FALUT	0000	00	00

↔
CS ID number (10 digits)

Example:

The CS ID number of CS number 03 is "8012301260".
The CS ID number of CS number 04 is "8012300360".

The location of the CS numbers are shown below.
KX-TD144: CS 01, CS 02, CS 07, CS 08
KX-TD146: CS 01 through CS 12

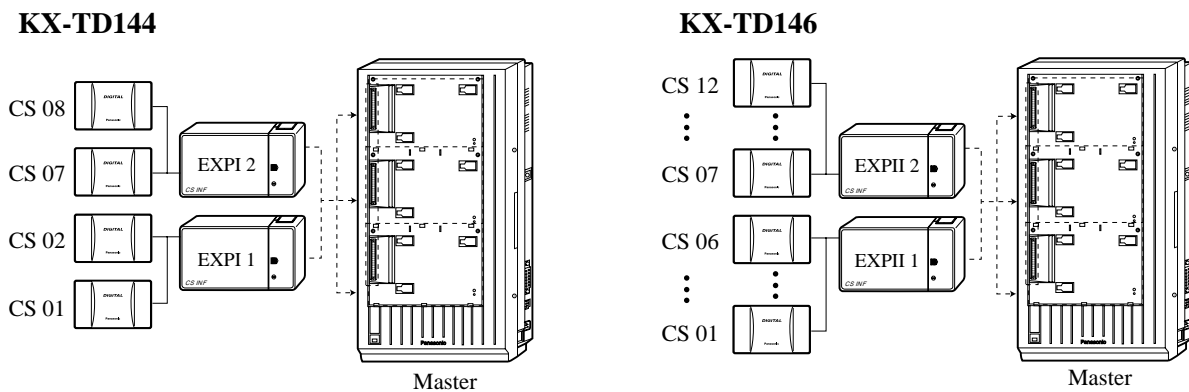



* EXPI : KX-TD144 (Cell Station Interface Unit)
EXPII: KX-TD146 (Cell Station Interface Unit)

Note

- The KX-TD144 / KX-TD146 can only be installed to the Master System.
- One EXP for the KX-TD816 and a maximum of two EXPs for the KX-TD1232 can be installed per system.

Assigning the Cell Station ID Number to the PS

1. Set the PS **Power Switch** to **ON** while pressing  (Talk),  (Recall) and  at the same time.

Display: FUNCTION<0-4>

2. Press .

Display example: CS NO?(1-8)

3. Enter the **Cell Station number**.







Display example: CS ID1=
→

4. Press  (Talk).

Display example: CS ID1=
→

5. Enter the **Cell Station ID number**.

- To enter letters, press the following buttons.

A	 (Hold)	D	 (Function)
B	 (OK)	E	 (Redial)
C	 (Book)	F	 (Recall)

Display example: CS ID1=
→0123456789

6. Press  (Talk).

- The assignment is completed.

Display example: CS NO?(1-8)

7. Repeat steps 3 through 6 to assign other Cell Station ID numbers.

8. Press  (Transfer) to return to the initial display.

Display: FUNCTION<0-4>

Unplugging the Cable from the Cell Station

After assigning the Cell Station ID number to the PS, unplug the cable from the Cell Station once.

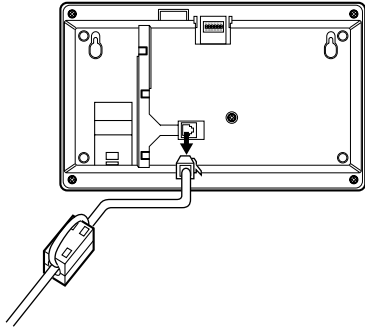

DIP-Switch Setting

After unplugging the Cell Station once, set the DIP-Switch as follows.

1. Switch the **Radio Signal Test Switch** from OFF to ON.
2. Set the **Channel Number Switches** as desired.

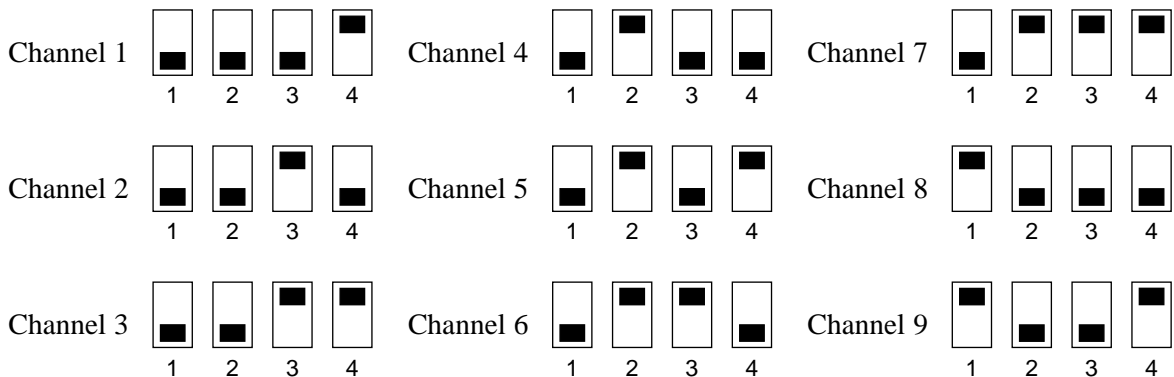
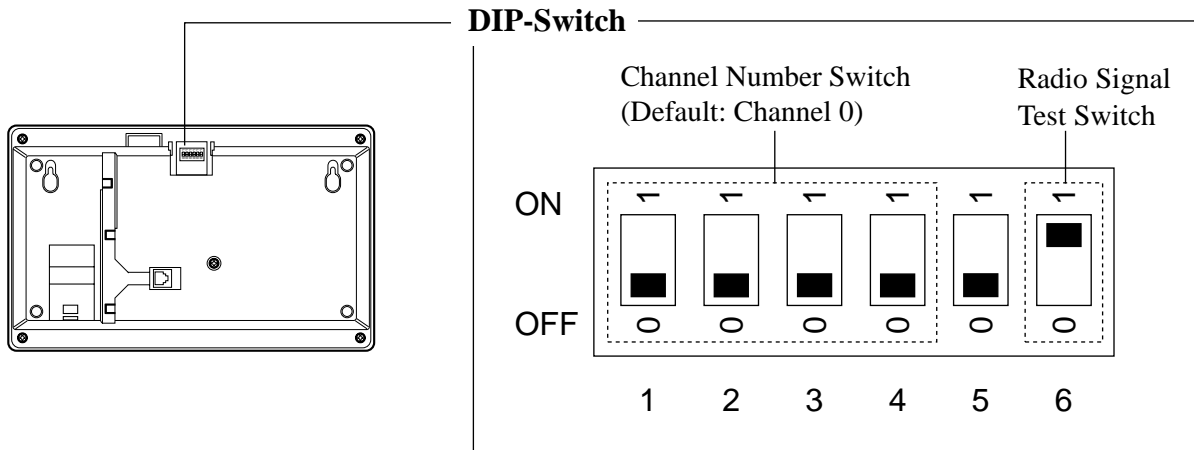

Note

- To see the signal strength of more than one Cell Station, the channel for each Cell Station needs to be set.
- Up to eight Cell Stations can be surveyed at the same time. If more than one Cell Station is in Radio Signal Test mode, each DIP-Switch channel must be different.

Connecting the AC Adaptor to the Cell Station

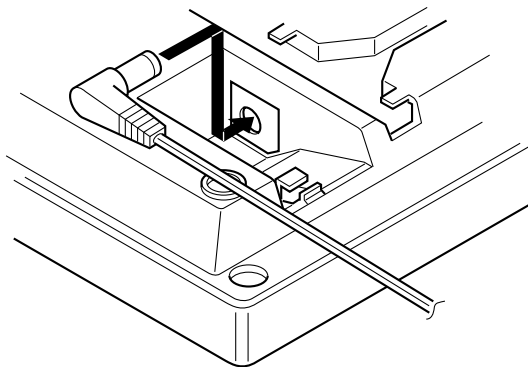

After setting the DIP-Switch, connect the AC Adaptor (KX-A11BS1: 230 VAC, 50 Hz) to the Cell Station.

**Note**



Only use the AC Adaptor for the Site Survey.

Radio Signal Test using the PS

After locating the Cell Station(s) temporarily, execute the Radio Signal Test using the PS. The PS scans whether there is a Cell Station that can link with on channel 0 right after entering the Radio Signal Test mode. The channel to be scanned can be changed by pressing the appropriate 0 through 9 keys.

1. Set the PS **Power Switch** to **ON** while pressing  (Talk),  (Recall) and  at the same time.

Display: FUNCTION<0-4>

2. Press .
 - **To survey other slots**, scroll by pressing  (Next) or  (Previous).
 - **To survey other channels**, enter the channel number (0 through 9).

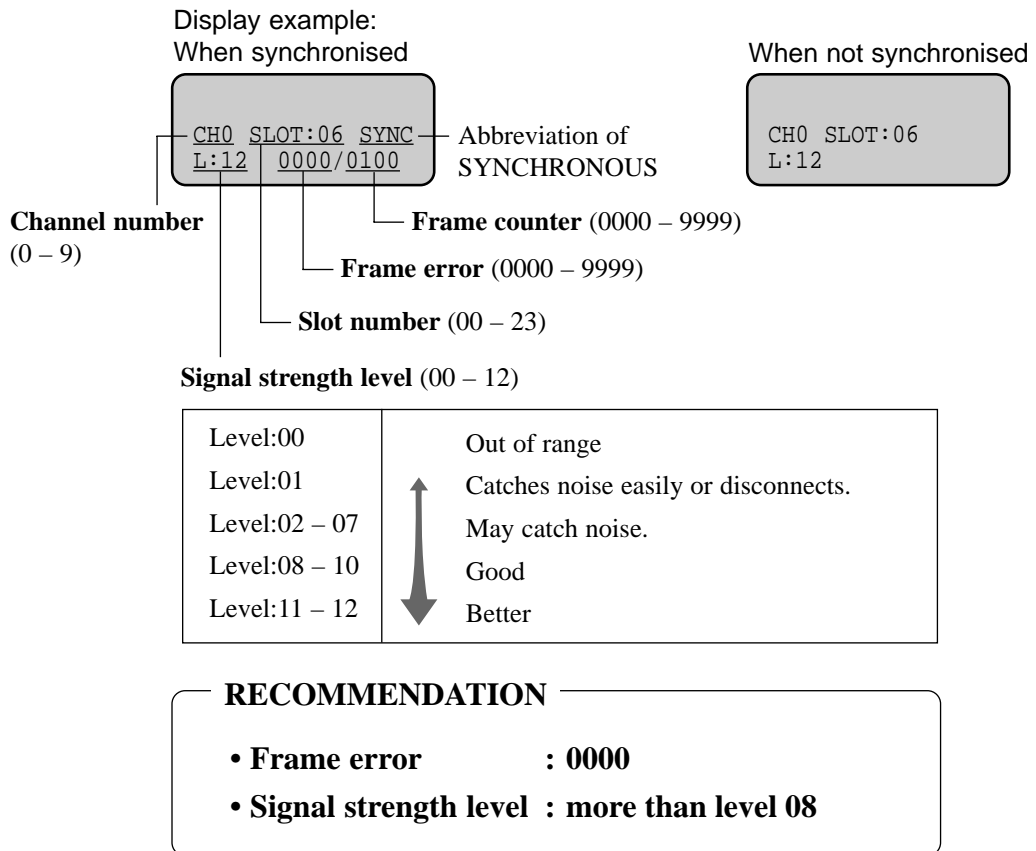

3. To record the result;

a) Press  (Talk).

- **Attention!!**
All directory data will be cleared.

To return to the test result display, press  (Clear).

Display: ALL BOOK DATA
IS CLEARED!!



Display: ARE YOU SURE?
TALK=YES , TRANS=NO

b) Press  (Talk).

- To clear all log data, press  (Recall).
Display: LOG NO.?(0-9)
FLASH=ALL CLR

c) Enter the **log number** (0 through 9).

Display example: LOG NO.?(0-9) 0
FLASH=ALL CLR

d) Press  (Talk).



- The result is recorded.

Display example: LOG NO.?(0-9) 0
STORED

Note

- The results of measurement for the 24 slots on the channel are saved each time a channel is set. If the same channel is set, the new results override the previous ones. Therefore, a measurement of 10 channels \times 24 slots in total can be made.
- If correct results cannot be obtained (e.g. there are many error counters), change the allocation of the Cell Station and repeat the site survey to select the best location.
- When a slot is synchronised in step 2 ("SYNC" is displayed), the other slots in the same channel show "OTHER".
- Please do not use several PSs for the test simultaneously. This may cause interference problems, so that the test may not be executed properly.

Referring to the recorded Radio Signal Test result

1. Set the PS Power Switch to ON while pressing  (Talk),  (Recall) and  at the same time.

Display: FUNCTION<0-4>

2. Press .

Display: RESULT OF SCAN
LOG NO.?(0-9)



3. Enter the desired **log number** (0 through 9).

Display example: RESULT OF SCAN
LOG NO.?(0-9) 0

4. Press  (Talk).

- The results of channel 0 and slot 0 will be displayed.

Display example: CH0 SLOT:00 SYNC
L:12 0000/0100

- **To go to another slot**, scroll by pressing  (Next) or  (Previous).
To go to another channel, enter the channel number (0 through 9).

After the Site Survey

After obtaining the proper measurement results, the following procedures are required before mounting the Cell Station to the wall.

1. **Disconnect** the AC adaptor.

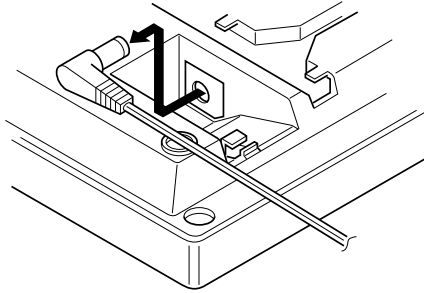

2. Switch the **Radio Signal Test Switch** of the Cell Station from ON to OFF.

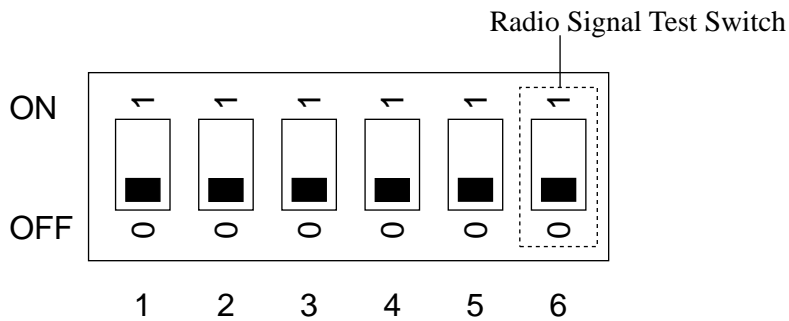

3. **Connect the cable** from the Cell Station Interface Unit the Cell Station, and pass the cord through the groove on the unit.

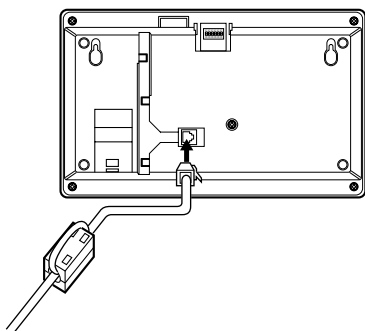

5.2.6 Wall Mounting

1. Place the template (included) on the wall to mark the two screw positions.
2. Install the two screws (included) into the wall.
3. Hook the Cell Station on the screw heads.

Mounting on Concrete or Mortar Walls

In step 2, drill two holes and drive the anchor plugs (included) with a hammer flush to the wall. Then install the screws into the anchor plugs.

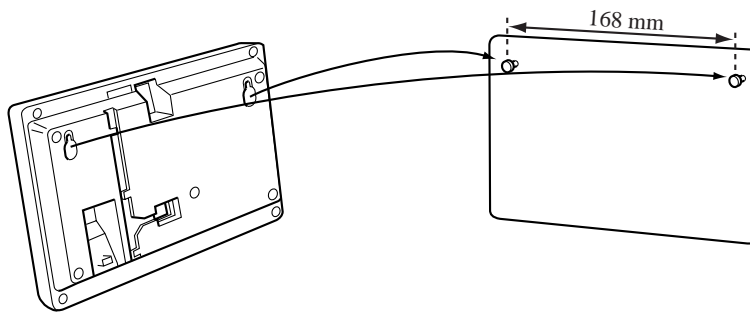

Section 6
Troubleshooting

6.1 Troubleshooting

6.1.1 Installation

PROBLEM	PROBABLE CAUSE	POSSIBLE SOLUTION
Extension does not operate.	<p>Bad printed circuit board (Extension Card).</p> <p>Bad connection between the system and extension.</p> <p>A telephone with an A-A1 relay is connected.</p> <p>Bad extension.</p>	<p>Exchange printed circuit board for another printed circuit board.</p> <p>Take the extension and plug it into the same extension port using a short telephone cord. If the telephone does not work, the connection between the system and the extension must be repaired.</p> <p>Use a 2 wire cord. Set the A-A1 relay switch of the telephone to the "OUT" or "OFF" position.</p> <p>Take the extension and plug it into another extension port that is working. If the telephone does not work, replace the phone.</p>
Incorrect reset operation.		Press the Reset Button.
Noise in external paging.	Induced noise on the wire between the system and the amplifier.	Use a shielded cable as the connection wire between the system and amplifier. A short shielded cable is recommended.
Volume distortion from external music source.	Excessive input level from external music source.	Decrease the output level of the external music source by using the volume control on the music source.
Speed Dialling or One-Touch Dialling does not function.	Bad programming.	Enter the outside line access number (9, 81 through 88) into programming.

6.1.2 Connection

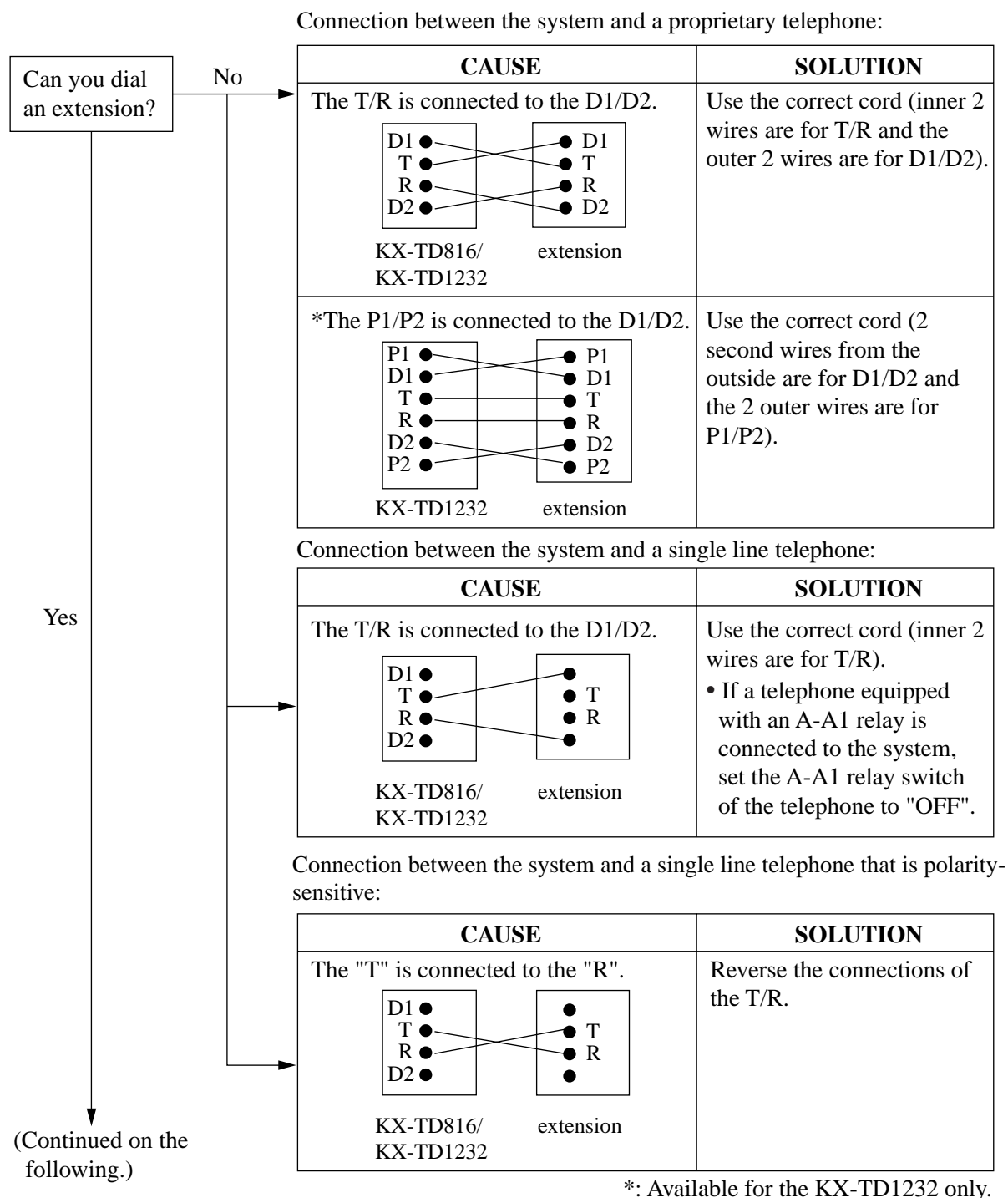

Connection between the central office and the system:

(Continued from the previous.)

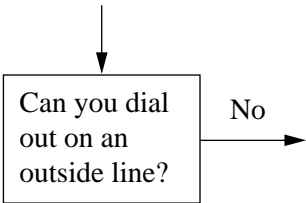

CAUSE	SOLUTION
<p>Outside lines are connected to the T2/T1.</p> <p>Outside line</p> <p>KX-TD816/ KX-TD1232</p>	<p>Reconnect the outside lines to the T1/R1 or T2/R2 of the telephone jack using 2-conductor wiring.</p>
<p>Outside lines are connected to the T2/R1.</p> <p>Outside line</p> <p>KX-TD816/ KX-TD1232</p>	

6.1.3 Operation

PROBLEM	PROBABLE CAUSE	POSSIBLE SOLUTION
<ul style="list-style-type: none"> When using the speakerphone mode with a analogue proprietary telephone, nothing is audible. When using the speakerphone/monitor mode with a digital proprietary telephone, nothing is audible. 	<ul style="list-style-type: none"> The HANDSET / HEADSET selector is set to the "HEADSET" position. The "HEADSET" mode is selected by Station Programming, "Handset/ Headset Selection". 	<ul style="list-style-type: none"> When the headset is not used, set the HANDSET / HEADSET selector to the "HANDSET" position. When the headset is not used, select the "HANDSET" mode by Station Programming.
The unit does not ring.	The Ringer Volume Selector is set to "OFF".	Set to "HIGH" or "LOW".
During a power failure, extensions connected to jack numbers 01, 02, 09, 10 for KX-TD816, and 01, 02, 09, 10, 17, 18 for KX-TD1232 do not operate.	<ul style="list-style-type: none"> A digital or analogue proprietary telephone (DPT / APT) is connected to the jack. The dialling mode (tone or pulse) is improper. 	<ul style="list-style-type: none"> Disconnect the DPT or APT and connect a single line telephone. Set the Tone / Pulse switch to the other position.
During system connection operation for KX-TD1232, originating an intercom/ outside call from one system to the other system is not possible.	Interface between the systems is disconnected.	Connect the interface between the systems and press the Reset Button on both systems.
Originating an outside call, Call Transfer, or Conference cannot be performed.	The corresponding CO button does not exist on the proprietary telephone.	Programme the CO button. See Programme [005] Flexible CO Button Assignment in the Programming Guide.

6.1.4 Using the Reset Button

If the system does not operate properly, use the Reset Button.

(If Master and Slave Systems are in operation by System Connection for KX-TD1232, reset both systems.)

Before using the Reset Button, try the system feature again to confirm whether there definitely is a problem or not.

Note

- When the System Clear Switch is set to "NORMAL", pressing the Reset Button causes the following:
 1. Camp-on is cleared.
 2. Calls on Hold are terminated.
 3. Calls on Exclusive Hold are terminated.
 4. Calls in progress are terminated.
 5. Call Park is cleared.All other data stored in memory is not cleared.
- When the System Clear Switch is set to the "CLEAR" position, you must press the Reset Button with caution. All data stored in memory will be cleared by the following operation: pressing the Reset Button and setting the System Clear Switch to the "NORMAL" position while the Power Indicator is flashing.

Operation

1. If the system does not operate properly,
 - a) Make sure that the System Clear Switch is set to the "NORMAL" position.
 - b) Press the Reset Button with a pointed tool.
2. If the system still does not operate properly,
 - a) Set the System Clear Switch to the "CLEAR" position.
 - b) Press the Reset Button with a pointed tool.
 - c) Return the System Clear Switch to the "NORMAL" position while the Power Indicator is flashing (approximately within 10 seconds).
3. If the system still does not work, switch the power off and on again after five minutes.
4. If the system still does not work,
 - a) Switch the power off.
 - b) Set the System Clear Switch to the "CLEAR" position.
 - c) Switch the power on.
 - d) Press the Reset Button with a pointed tool.
 - e) Set the System Clear Switch to the "NORMAL" position while the Power Indicator is flashing (approximately within 10 seconds).
5. If the system still does not work, switch the power off. If car batteries are connected to the system, disconnect them, too. Then consult an authorised service person.

When the power supply stops, certain extensions are automatically connected straight to specific outside lines:

KX-TD816

Extension (T, R) of jack number 01: Outside line 01

Extension (T, R) of jack number 02: Outside line 02

Extension (T, R) of jack number 09: Outside line 05

Extension (T, R) of jack number 10: Outside line 06

KX-TD1232

Extension (T, R) of jack number 01: Outside line 01

Extension (T, R) of jack number 02: Outside line 02

Extension (T, R) of jack number 09: Outside line 03

Extension (T, R) of jack number 10: Outside line 04

Extension (T, R) of jack number 17: Outside line 09

Extension (T, R) of jack number 18: Outside line 10

Connect single line telephones to the above extension jacks.

Section 7
Index

Numerics

- 16 SLT Line Circuit Unit (KX-TD174) 22
- 2-ISDN S0 Line Unit (KX-TD280) 22, 122, 123, 124, 127, 130
- 4-CO Line Unit (KX-TD180) 22, 69, 70, 74, 86
- 4-CO Line Unit Connection 74
- 6-ISDN S0 Line Unit (KX-TD286) 22, 122, 123, 124, 127, 130
- 8-Station Line Unit (KX-TD170) 22, 69, 70, 75, 79, 81
- 8-Station Line Unit Connection 75

A

- AC Adaptor (KX-A277) 24, 156, 157, 161
- Add-on Key Module (KX-T7545) 24
- Amphenol 57JE Type 81
- Auxiliary Connection for Power Failure Transfer 112

B

- Backup Battery and Adaptor Card (KX-A216) 71
- Basic System Capacity 14
- Basic System Construction 16
- Battery Adaptor (KX-A46) 24, 103, 109
- Battery Adaptor Connection 109
- Before Installation 34

C

- Cell Station 158
- Cell Station (KX-TD142) 22, 148, 154, 155, 156, 157
- Cell Station ID Number 167, 169
- Cell Station Interface Unit 158
- Cell Station Interface Unit (KX-TD144) 22, 148, 154, 155
- Cell Station Interface Unit (KX-TD146) 22, 148, 156, 157
- Channel Number Switches 170
- Characteristics 29, 100
- Closing the Front Cover 105, 114

D

- DECT Portable Station (KX-TD7500) 148
- Digital Attendant Console (KX-T7541) 24
- Digital DSS Console (KX-T7240) 24
- Digital DSS Console (KX-T7440) 24
- Digital DSS Console (KX-T7540) 24
- DIP-Switch Setting 170
- DISA Card (KX-TD191) 23, 72, 87, 92
- DISA Card (KX-TD199) 23, 69, 87, 88
- DISA Unit (KX-TD190) 22, 69, 87, 90
- Display Language 165
- Door Opener Connection 94
- Doorphone (KX-T30865) 24, 94
- Doorphone Card (KX-TD160) 24, 71, 72, 94
- Doorphone Connection 94
- DSS Console (KX-T7040) 24
- DSS Console (KX-T7340) 24
- DSS Console for Attendant (KX-T7441) 24

E

- E & M (TIE) Line Connection 142
- E & M (TIE) Line Service 15, 134
- E & M (TIE) Line Unit (KX-TD184) 22, 134, 136, 137
- Expansion Unit Combination 25
- Extension Connection 45
- External Music Source Connection 60
- External Pager (Paging Equipment) Connection 57
- EXtra Device Port (XDP) 14
- EXtra Device Port (XDP) Connection 54

F

- Ferrite Core 160, 161
- Frame Ground Connection 41, 101, 160

G

- Ground 41, 101, 127, 128, 160

H

- High Speed Remote Card (KX-TD197) 23, 69, 72, 87, 88, 93

I

- Installing Expansion Unit 77
- Internal ISDN S0 Line Connection 130
- ISDN Line Service 15, 122
- ISDN Terminal Equipment (TE) 131, 132

K

- KX-A216 (Backup Battery and Adaptor Card) 71
- KX-A277 (AC Adaptor) 24, 156, 157, 161
- KX-A46 (Battery Adaptor) 24, 103, 109
- KX-T30865 (Doorphone) 24, 94
- KX-T7040 (DSS Console) 24
- KX-T7240 (Digital DSS Console) 24
- KX-T7340 (DSS Console) 24
- KX-T7440 (Digital DSS Console) 24
- KX-T7441 (DSS Console for Attendant) 24
- KX-T7540 (Digital DSS Console) 24
- KX-T7541 (Digital Attendant Console) 24
- KX-T7545 (Add-on Key Module) 24
- KX-TD142 (Cell Station) 22, 148, 154, 155, 156, 157
- KX-TD144 (Cell Station Interface Unit) 22, 148, 154, 155
- KX-TD146 (Cell Station Interface Unit) 22, 148, 156, 157
- KX-TD160 (Doorphone Card) 24, 71, 72, 94
- KX-TD170 (8-Station Line Unit) 22, 69, 70, 75, 79, 81
- KX-TD174 (16 SLT Line Circuit Unit) 22
- KX-TD180 (4-CO Line Unit) 22, 69, 70, 74, 86
- KX-TD184 (E & M (TIE) Line Unit) 22, 134, 136, 137
- KX-TD189 (Pay Tone Card) 22, 71, 72
- KX-TD190 (DISA Unit) 22, 69, 87, 90

-
- KX-TD191 (DISA Card) 23, 72, 87, 92
 - KX-TD192 (System Inter Connection Card) 23, 72, 107
 - KX-TD194 (SLT Message Waiting Lamp Adaptor Unit) 23, 73
 - KX-TD196 (Remote Card) 23, 72, 87, 93
 - KX-TD197 (High Speed Remote Card) 23, 69, 72, 87, 88, 93
 - KX-TD198 (Remote Unit) 23, 69, 87, 90
 - KX-TD199 (DISA Card) 23, 69, 87, 88
 - KX-TD280 (2-ISDN S0 Line Unit) 22, 122, 123, 124, 127, 130
 - KX-TD286 (6-ISDN S0 Line Unit) 22, 122, 123, 124, 127, 130
 - KX-TD290 (Primary Rate Interface ISDN Expansion Unit) 22, 122, 124, 128
 - KX-TD7500 (DECT Portable Station) 148
 - L**
 - Lightning Protectors 66
 - Location of Interfaces 37
 - Location of Optional Cards and Unit 69
 - Location of the Unit 136, 154
 - M**
 - Maximum Cabling Distance 45, 46, 98
 - O**
 - Opening the Front Cover 42, 101
 - Options 22
 - Outside Line Connection 43
 - P**
 - Paralleled Telephone Connection 14, 52
 - Pay Tone Card (KX-TD189) 22, 71, 72
 - Pay Tone Card Installation 84
 - Pin Number Chart 49, 103, 142
 - Polarity Sensitive Telephone Connection 55
 - Power Failure Transfer 112
 - Primary Rate Interface ISDN Expansion Unit (KX-TD290) 22, 122, 124, 128
 - Printer and PC Connection 63
 - Proprietary Telephones 21
 - R**
 - Radio Signal Test 171
 - Radio Signal Test Switch 170, 174
 - Radio Waves 151
 - Remote Card (KX-TD196) 23, 72, 87, 93
 - Remote Unit (KX-TD198) 23, 69, 87, 90
 - Reset Button 116, 118, 119, 182
 - RF Specifications 149
 - S**
 - Serial Interface (RS-232C) connector 63
 - Serial Interface (RS-232C) Signals 65
 - Site Planning 151
 - Site Survey 166
 - SLT Message Waiting Lamp Adaptor Unit (KX-TD194) 23, 73
 - SLT Message Waiting Lamp Adaptor Unit
 - Connection 99
 - Specifications 99, 135, 149
 - Starting the System for the First Time 116
 - System Capacity 14, 30
 - System Clear Switch 116, 118, 119, 182
 - System Connection 15, 107
 - System Connection Diagram 17
 - System Data Clear 119
 - System Highlights 14
 - System Inter Connection Card (KX-TD192) 23, 72, 107
 - System Restart 118
 - T**
 - Telephone Wiring 45, 46
 - Terminating Resistors (TR) 132
 - U**
 - Unpacking 36
 - W**
 - Wall Mounting 39, 100, 110, 175
 - Wireless Extension Connection 160
 - Wireless System 15, 148
-

This PBX except KX-TD816PD fulfills the requirements of following European regulations:

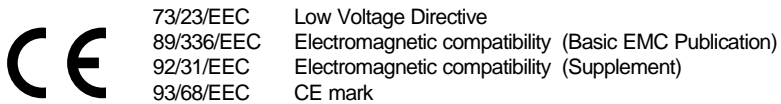

For above mentioned standards the unit is signed with the CE-mark.

Warning:

This is a Class A product. In a domestic environment this product may cause radio interference in which case the user may be required to take adequate measures.

Kyushu Matsushita Electric Co., Ltd.

1-62, 4-chome, Minoshima, Hakata-ku, Fukuoka 812-8531, Japan

Copyright:

This manual is copyrighted by Kyushu Matsushita Electric Co., Ltd. (KME). Under the applicable copyright laws, this manual may not be reproduced in any form, in whole or part, without the prior written consent of KME.

© Kyushu Matsushita Electric Co., Ltd. 2000