

Service Manual

Digital Camera

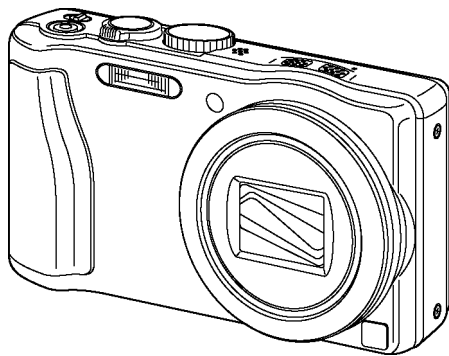

- Model No. **DMC-TZ27EB**
DMC-TZ27EC
DMC-TZ30EB
DMC-TZ30EE
DMC-TZ30EF
DMC-TZ30EG
DMC-TZ30EP
DMC-TZ30GA
DMC-TZ30GC
DMC-TZ30GN
DMC-TZ30SG
DMC-TZ31EG
DMC-ZS19P
DMC-ZS20P
DMC-ZS20PC
DMC-ZS20PU
DMC-ZS20GH
DMC-ZS20GK
DMC-ZS20GT

Colours

- (S).....Silver Type (except DMC-TZ27EB/EC,
TZ30EE/EF/GN/SG, ZS19P, ZS20GT)
(K).....Black Type
(R).....Red Type (except DMC-TZ27EB/EC,
TZ30EP, ZS19P, ZS20GH/GK/GT)

Panasonic[®]

© Panasonic Corporation 2012.
Unauthorized copying and distribution is a violation
of law.

- (T).....Brown Type (except DMC-TZ27EB/EC,
TZ30EB/SG, ZS19P, ZS20P/PC/PU)
(W).....White Type (except DMC-TZ27EB/EC,
TZ30EE/GC, ZS19P, ZS20PC/PU/GH)

⚠ **WARNING**

This service information is designed for experienced repair technicians only and is not designed for use by the general public. It does not contain warnings or cautions to advise non-technical individuals of potential dangers in attempting to service a product. Products powered by electricity should be serviced or repaired only by experienced professional technicians. Any attempt to service or repair the product or products dealt with in this service information by anyone else could result in serious injury or death.

TABLE OF CONTENTS

	PAGE		PAGE
1 Safety Precautions	3	12.4. Sensor Block Diagram	60
1.1. General Guidelines	3	12.5. Lens Drive Block Diagram.....	61
1.2. Leakage Current Cold Check	3	12.6. Power Block Diagram.....	62
1.3. Leakage Current Hot Check (See Figure 1).....	3	13 Wiring Connection Diagram	63
1.4. How to Discharge the Capacitor on Flash P.C.B.	4	13.1. Interconnection Schematic Diagram.....	63
2 Warning	5		
2.1. Prevention of Electrostatic Discharge (ESD) to Electrostatic Sensitive (ES) Devices	5		
2.2. How to Recycle the Lithium Ion Battery (U.S. Only).....	5		
2.3. How to Replace the Lithium Battery	6		
3 Service Navigation	8		
3.1. Introduction	8		
3.2. Service Navigation.....	8		
3.3. General Description About Lead Free Solder (PbF)	9		
3.4. How to Define the Model Suffix (NTSC or PAL model).....	10		
4 Specifications	16		
5 Location of Controls and Components	18		
6 Service Mode	20		
6.1. Error Code Memory Function	20		
7 Troubleshooting Guide	24		
7.1. Checking Method of GPS failure (Except: TZ27EB/EC, ZS19P and 20GK).....	24		
8 Service Fixture & Tools	26		
8.1. Service Fixture and Tools	26		
8.2. When Replacing the Main P.C.B.	26		
8.3. Service Position	27		
9 Disassembly and Assembly Instructions	28		
9.1. Disassembly Flow Chart.....	28		
9.2. P.C.B. Location	28		
9.3. Disassembly Procedure	29		
9.4. Lens Disassembly Procedure.....	36		
9.5. Assembly Procedure for Lens (Revised Version).....	40		
9.6. Removal of the CMOS Unit.....	48		
10 Measurements and Adjustments	49		
10.1. Introduction	49		
10.2. Before Disassembling the unit	49		
10.3. Details of Electrical Adjustment.....	51		
10.4. After Adjustment.....	55		
11 Maintenance	56		
11.1. Cleaning Lens, Viewfinder and LCD Panel.....	56		
12 Block Diagram	57		
12.1. Overall Block Diagram	57		
12.2. System Control Block Diagram.....	58		
12.3. Audio/Video Process/ HDMI Block Diagram	59		

1 Safety Precautions

1.1. General Guidelines

1. IMPORTANT SAFETY NOTICE

There are special components used in this equipment which are important for safety. These parts are marked by \triangle in the Schematic Diagrams, Circuit Board Layout, Exploded Views and Replacement Parts List. It is essential that these critical parts should be replaced with manufacturer's specified parts to prevent X-RADIATION, shock fire, or other hazards. Do not modify the original design without permission of manufacturer.

2. An Isolation Transformer should always be used during the servicing of AC Adaptor whose chassis is not isolated from the AC power line. Use a transformer of adequate power rating as this protects the technician from accidents resulting in personal injury from electrical shocks. It will also protect AC Adaptor from being damaged by accidental shorting that may occur during servicing.
3. When servicing, observe the original lead dress. If a short circuit is found, replace all parts which have been overheated or damaged by the short circuit.
4. After servicing, see to it that all the protective devices such as insulation barriers, insulation papers shields are properly installed.
5. After servicing, make the following leakage current checks to prevent the customer from being exposed to shock hazards.

1.2. Leakage Current Cold Check

1. Unplug the AC cord and connect a jumper between the two prongs on the plug.
2. Measure the resistance value, with an ohmmeter, between the jumpered AC plug and each exposed metallic cabinet part on the equipment such as screwheads, connectors, control shafts, etc. When the exposed metallic part has a return path to the chassis, the reading should be between $1M\Omega$ and $5.2M\Omega$. When the exposed metal does not have a return path to the chassis, the reading must be infinity.

1.3. Leakage Current Hot Check (See Figure 1)

1. Plug the AC cord directly into the AC outlet. Do not use an isolation transformer for this check.
2. Connect a $1.5k\Omega$, 10 W resistor, in parallel with a $0.15\mu F$ capacitor, between each exposed metallic part on the set and a good earth ground, as shown in Figure 1.
3. Use an AC voltmeter, with 1 k Ω/V or more sensitivity, to measure the potential across the resistor.
4. Check each exposed metallic part, and measure the voltage at each point.
5. Reverse the AC plug in the AC outlet and repeat each of the above measurements.
6. The potential at any point should not exceed 0.75 V RMS. A leakage current tester (Simpson Model 229 or equivalent) may be used to make the hot checks, leakage current must not exceed 1/2 mA. In case a measurement is outside of the limits specified, there is a possibility of a shock hazard, and the equipment should be repaired and rechecked before it is returned to the customer.

Hot-Check Circuit

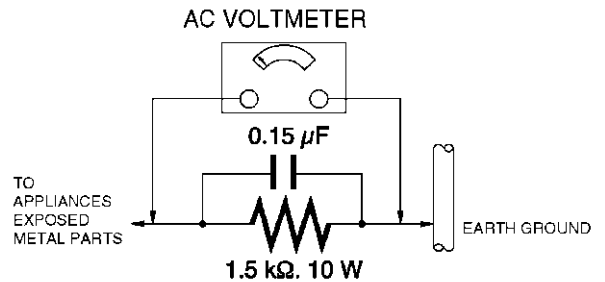

Figure 1

1.4. How to Discharge the Capacitor on Flash P.C.B.

CAUTION:

1. Be sure to discharge the capacitor on Flash P.C.B.
2. Be careful of the high voltage circuit on Flash P.C.B. when servicing.

[Discharging Procedure]

1. Refer to the disassemble procedure and remove the necessary parts/unit.
2. Install the insulation tube onto the lead part of Resistor (ERG5SJ102:1k Ω /5W).
(an equivalent type of resistor may be used.)
3. Place a resistor between both terminals of capacitor on the Flash P.C.B. for approx. 5 seconds.
4. After discharging, confirm that the capacitor voltage is lower than 10V using a voltmeter.

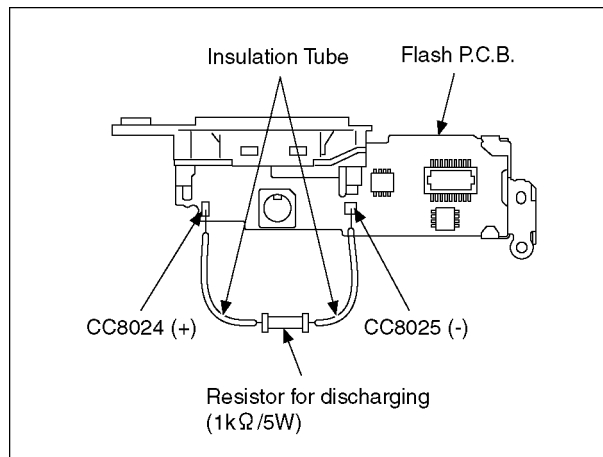

Fig. F1

2 Warning

2.1. Prevention of Electrostatic Discharge (ESD) to Electrostatic Sensitive (ES) Devices

Some semiconductor (solid state) devices can be damaged easily by static electricity. Such components commonly are called Electrostatically Sensitive (ES) Devices.

Examples of typical ES devices are C-MOS image sensor, IC (integrated circuits) and some field-effect transistors and semiconductor "chip" components.

The following techniques should be used to help reduce the incidence of component damage caused by electrostatic discharge (ESD).

1. Immediately before handling any semiconductor component or semiconductor-equipped assembly, drain off any ESD on your body by touching a known earth ground. Alternatively, obtain and wear a commercially available discharging ESD wrist strap, which should be removed for potential shock reasons prior to applying power to the unit under test.
2. After removing an electrical assembly equipped with ES devices, place the assembly on a conductive surface such as aluminum foil, to prevent electrostatic charge buildup or exposure of the assembly.
3. Use only a grounded-tip soldering iron to solder or unsolder ES devices.
4. Use only an antistatic solder removal device. Some solder removal devices not classified as **antistatic (ESD protected)** can generate electrical charge sufficient to damage ES devices.
5. Do not use freon-propelled chemicals. These can generate electrical charges sufficient to damage ES devices.
6. Do not remove a replacement ES device from its protective package until immediately before you are ready to install it. (Most replacement ES devices are packaged with leads electrically shorted together by conductive foam, aluminum foil or comparable conductive material).
7. Immediately before removing the protective material from the leads of a replacement ES device, touch the protective material to the chassis or circuit assembly into which the device will be installed.

CAUTION:

Be sure no power is applied to the chassis or circuit, and observe all other safety precautions.

8. Minimize bodily motions when handling unpackaged replacement ES devices. (Otherwise harmless motion such as the brushing together of your clothes fabric or the lifting of your foot from a carpeted floor can generate static electricity (ESD) sufficient to damage an ES device).

2.2. How to Recycle the Lithium Ion Battery (U.S. Only)

ENGLISH



A lithium ion/polymer battery that is recyclable powers the product you have purchased. Please call 1-800-8-BATTERY for information on how to recycle this battery.

FRANÇAIS



L'appareil que vous vous êtes procuré est alimenté par une batterie au lithium-ion/polymère recyclable. Pour des renseignements sur le recyclage de la batterie, veuillez composer le 1-800-8-BATTERY.

2.3. How to Replace the Lithium Battery

2.3.1. Replacement Procedure

1. Remove the Top P.C.B. (Refer to Disassembly Procedures.)
2. Remove the Lithium battery (Ref. No. **B9901** at foil side of Top P.C.B.) and then replace it into new one.

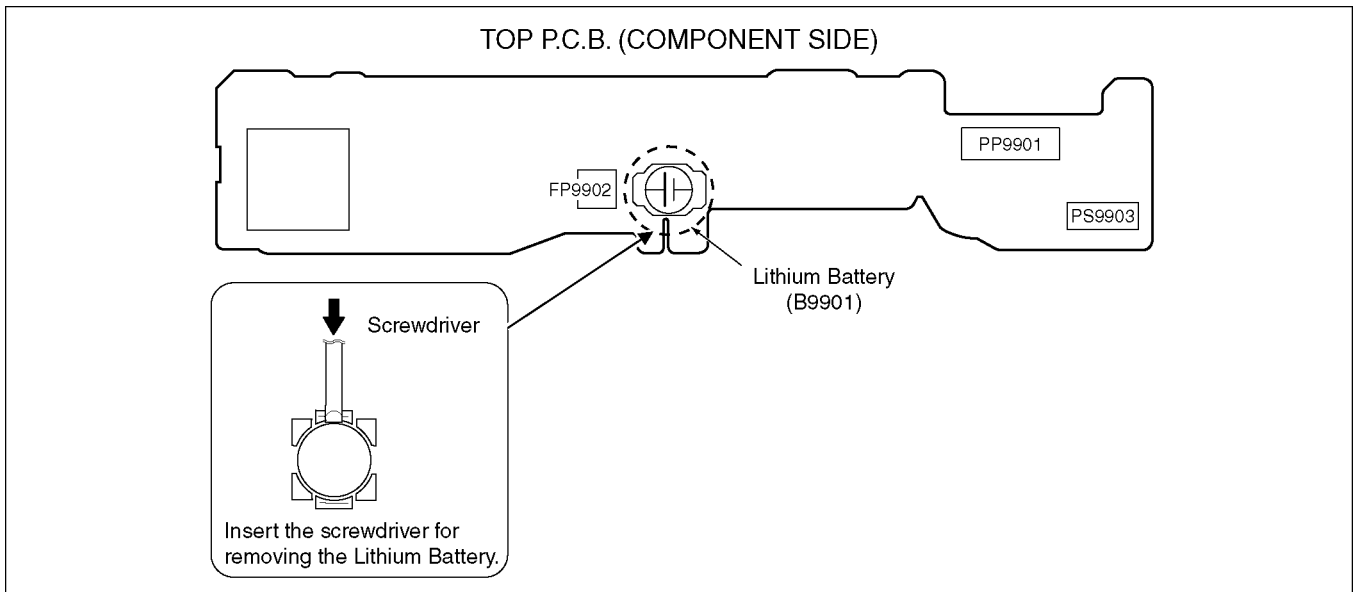

CAUTION

Danger of explosion if battery is incorrectly replaced.
Replace only with the same or equivalent type.

CAUTION

The battery used in this device may present a risk of fire or chemical burn if mistreated.
Do not recharge, disassemble, heat above 100°C (212°F), or incinerate.
Replace battery with Panasonic part number ML-421S/DN only.
Use of another battery may present a risk of fire or explosion.
Dispose of used battery promptly.
Keep away from children.
Do not disassemble and do not dispose of in fire.

Note:

The lithium battery is a critical component.
(Type No.: ML-421S/DN **Manufactured by Energy Company, Panasonic Corporation.**)
It must never be subjected to excessive heat or discharge.
It must therefore only be fitted in equipment designed specifically for its use.
Replacement batteries must be of the same type and manufacture.
They must be fitted in the same manner and location as the original battery, with the correct polarity contacts observed.
Do not attempt to re-charge the old battery or re-use it for any other purpose.
It should be disposed of in waste products destined for burial rather than incineration.

(For English)

CAUTION

Danger of explosion if battery is incorrectly replaced.
Replace only with the same or equivalent type recommended by the manufacturer.
Dispose of used batteries according to the manufacturer's instructions.

(For German)

ACHTUNG

Explosionsgefahr bei falschem Anbringen der Batterie. Ersetzen Sie nur mit einem äquivalentem vom Hersteller empfohlenem Typ.
Behandeln Sie gebrauchte Batterien nach den Anweisungen des Herstellers.

(For French)

MISE EN GARDE

Une batterie de remplacement inappropriée peut exploser. Ne remplacez qu'avec une batterie identique ou d'un type recommandé par le fabricant. L'élimination des batteries usées doit être faite conformément aux instructions du fabricant.

Note:

Above caution is applicable for a battery pack which is for DMC-TZ27/TZ30/TZ31/ZS19/ZS20 series, as well.

3 Service Navigation

3.1. Introduction

This service manual contains technical information, which will allow service personnel's to understand and service this model.

Please place orders using the parts list and not the drawing reference numbers.

If the circuit is changed or modified, the information will be followed by service manual to be controlled with original service manual.

3.2. Service Navigation

3.2.1. About lens block

The image sensor (CMOS) unit which are connected to the lens unit with 3 screws. 2 of these 3 screws are locked with the screw locking glue, after performing the Optical tilt adjustment. During servicing, if one of CMOS fixing screws are loosened, the Optical tilt adjustment must be performed.(About the Optical tilt adjustment, refer to the "10.3.2 Adjustment Specifications" for details.)

NOTE:

It is necessary to use the "DSC_Tilt" software to allow the "Optical tilt adjustment".

The Adjustment software "DSC_Tilt" is available at "TSN Website". To download, click on "Support Information from NWBG/VDBG-AVC".

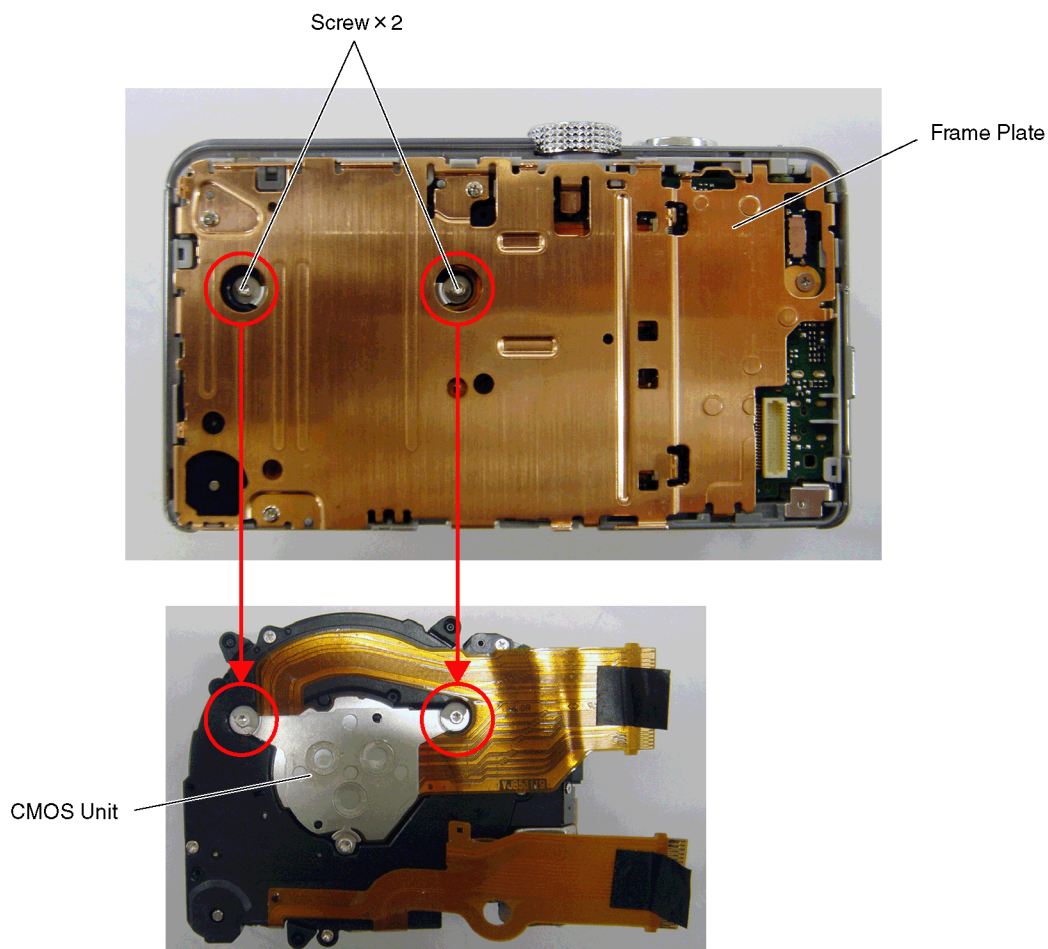

The Optical tilt adjustment can be performed with the Frame Plate attached

3.2.2. About VENUS ENGINE (IC6001) < Located on the Main P.C.B. >

- The VENUS ENGINE (IC6001) consists of two IC chips, which are fixed together with solder.
(It is so called, "Package On Package" type of IC.)

Caution:

- During servicing, do not press down hard on the surface of IC6001.

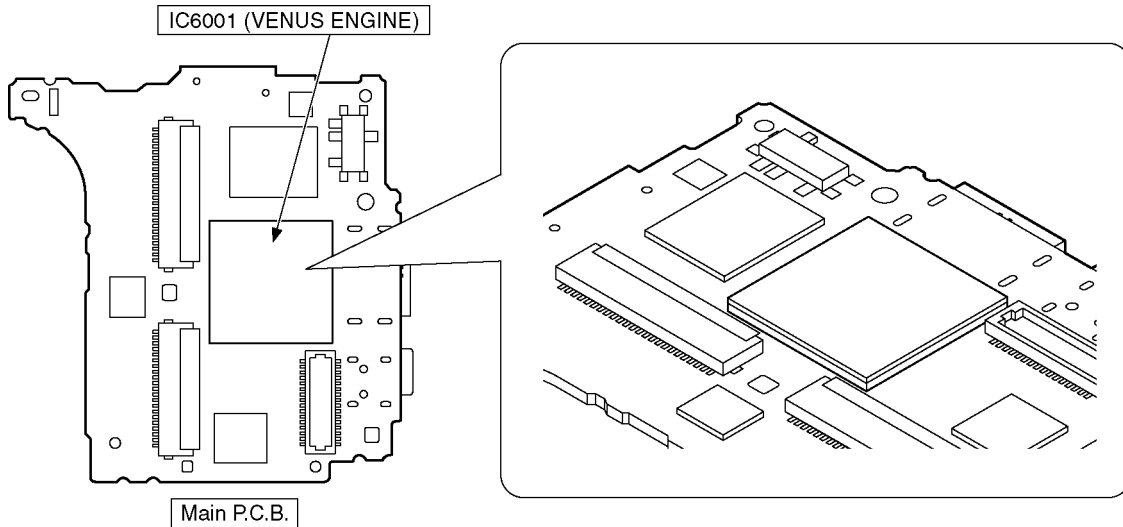

3.3. General Description About Lead Free Solder (PbF)

The lead free solder has been used in the mounting process of all electrical components on the printed circuit boards used for this equipment in considering the globally environmental conservation.

The normal solder is the alloy of tin (Sn) and lead (Pb). On the other hand, the lead free solder is the alloy mainly consists of tin (Sn), silver (Ag) and Copper (Cu), and the melting point of the lead free solder is higher approx.30 °C (86 °F) more than that of the normal solder.

Definition of PCB Lead Free Solder being used

The letter of PbF is printed either foil side or components side on the P.C.B. using the lead free solder. (See right figure)

PbF

Service caution for repair work using Lead Free Solder (PbF)

- The lead free solder has to be used when repairing the equipment for which the lead free solder is used.
- (Definition: The letter of **PbF** is printed on the P.C.B. using the lead free solder.)
- To put lead free solder, it should be well molten and mixed with the original lead free solder.
- Remove the remaining lead free solder on the P.C.B. cleanly for soldering of the new IC.
- Since the melting point of the lead free solder is higher than that of the normal lead solder, it takes the longer time to melt the lead free solder.
- Use the soldering iron (more than 70W) equipped with the temperature control after setting the temperature at 350±30 degrees C (662±86 °F).

Recommended Lead Free Solder (Service Parts Route.)

- The following 3 types of lead free solder are available through the service parts route.
 - RFKZ03D01KS-----(0.3mm 100g Reel)
 - RFKZ06D01KS-----(0.6mm 100g Reel)
 - RFKZ10D01KS-----(1.0mm 100g Reel)

Note:

* Ingredient: tin (Sn) 96.5%, silver (Ag) 3.0%, Copper (Cu) 0.5%, Cobalt (Co) / Germanium (Ge) 0.1 to 0.3%

3.4. How to Define the Model Suffix (NTSC or PAL model)









There are nine kinds of DMC-TZ27/TZ30/TZ31/ZS19/ZS20, regardless of the colours.

- a) DMC-TZ30 (Japan domestic model.) /SG
- b) DMC-ZS20P/PC
- c) DMC-ZS19P
- d) DMC-TZ27EB/EC, TZ30EB/EE/EF/EG/EP, TZ31EG
- e) DMC-TZ30EE
- f) DMC-ZS20GT
- g) DMC-TZ30GN
- h) DMC-ZS20GK
- i) DMC-TZ30GA/GC, ZS20PU/GH

What is the difference is that the "INITIAL SETTINGS" data which is stored in Flash ROM mounted on Main P.C.B.

3.4.1. Defining methods

To define the model suffix to be serviced, refer to the nameplate which is putted on the bottom side of the Unit.

<p>a) DMC-TZ30 (Japan domestic model) /SG The nameplate for this model shows the following Safety registration mark.</p>	 <p style="text-align: center;">Safety registration mark</p>
	
<p>b) DMC-ZS20P/PC The nameplate for these models show the following Safety registration mark.</p>	
	
<p>c) DMC-ZS19P The nameplate for these models show the following Safety registration mark.</p>	
	
<p>c) DMC-TZ27EB/EC, TZ30EB/EF/EG/EP, TZ31EG The nameplate for these models show the following Safety registration mark.</p>	<p>g) DMC-TZ30GN The nameplate for these models show the following Safety registration mark.</p>
	
<p>d) DMC-TZ30EE The nameplate for this model show the following Safety registration mark.</p>	<p>h) DMC-ZS20GK The nameplate for these models show the following Safety registration mark.</p>
	
<p>e) DMC-ZS20GT The nameplate for this model show the following Safety registration mark.</p>	<p>i) DMC-TZ30GA/GC, DMC-ZS20PU/GH The nameplate for these models do not show any above safety registration mark.</p>
	

Note:

After replacing the Main P.C.B., be sure to achieve adjustment.

The Maintenance software (DIAS) is available at "software download" on the "Support Information from NWBG/VDBG-AVC" web-site in "TSN system".

3.4.2. INITIAL SETTINGS:

After replacing the Main P.C.B., make sure to perform the initial settings after achieving the adjustment by ordering the following procedure in accordance with model suffix of the unit.

1. IMPORTANT NOTICE:

Before proceeding Initial settings, be sure to read the following CAUTIONS.

CAUTION 1:(INITIAL SETTINGS)

--- AFTER REPLACING THE MAIN P.C.B. and/or FLASH ROM ---

**[Except "DMC-TZ30EG/EF/EB/EP, TZ31EG and DMC-TZ27EB/EC" models :
(VEP56159A/D is used as a Main P.C.B.)]**

*.The model suffix can be chosen **JUST ONE TIME**.

(Effective model suffix : "DMC-TZ30EE/GC/GA/SG and GN, DMC-ZS20P/PC/PU/GH/GK and GT, DMC-ZS19P")

*.Once one of the model suffix has been chosen, the model suffix lists will not be displayed, thus, it can not be changed.

[Only for "DMC-TZ30EG/EF/EB/EP and TZ31EG" models : (VEP56159B is used as a Main P.C.B.)]

*.From the beginning, only "DMC-TZ30EG/EF/EB/EP and TZ31EG" are displayed as a model suffix lists, and these are displayed from the second times as well.

[Only for "DMC-TZ27EB/EP" models : (VEP56159C is used as a Main P.C.B.)]

*.From the beginning, only "DMC-TZ27EB/EP" are displayed as a model suffix lists, and these are displayed from the second times as well.

CAUTION 2:(Stored picture image data in the unit)

This unit employs "Built-in Memory" for picture image data recording.(Approx.70MB)

After proceeding "INITIAL SETTINGS", the picture image data stored in the unit is erased.

2. PROCEDURES:

• Precautions: Read the above "CAUTION 1" and "CAUTION 2", carefully.

• Preparation:

1. Attach the Battery or AC Adaptor with a DC coupler to the unit.

2. Set the mode dial to the PROGRAM AE mode.

Note: If the mode dial position is other than PROGRAM AE mode, it does not display the initial settings menu.

• **Step 1. The temporary cancellation of "INITIAL SETTINGS":**

Set the REC/PLAYBACK selector switch to "REC (Camera mark)".

While keep pressing "UP of Cursor button" and MOTION PICTURE button simultaneously, turn the Power SW on.

• **Step 2. The cancellation of "INITIAL SETTINGS":**

Set the REC/PLAYBACK selector switch to "PLAYBACK".

Press "UP of Cursor button" and MOTION PICTURE button simultaneously, then turn the Power SW off.

• **Step 3. Turn the Power on:**

Set the REC/PLAYBACK selector switch to "REC (Camera mark)", and then turn the Power SW on.

• **Step 4. Display the "INITIAL SETTINGS" menu:**

Note: If the unit is other than PROGRAM AE mode, it does not display the initial settings menu.

While keep pressing MENU/SET and "RIGHT of Cursor button" simultaneously, turn the Power SW off.

The "INITIAL SETTINGS" menu is displayed.

There are two kinds of "INITIAL SETTINGS" menu form as follows:

[CASE 1. After replacing MAIN P.C.B.]

There are four kinds of menu from as follows:

[Except for "DMC-TZ30EG, EF, EB and EP" models : (VEP56159A is used as a Main P.C.B.)]

When Main P.C.B. has just been replaced, all of the model suffix are displayed as follows. (Four pages in total)

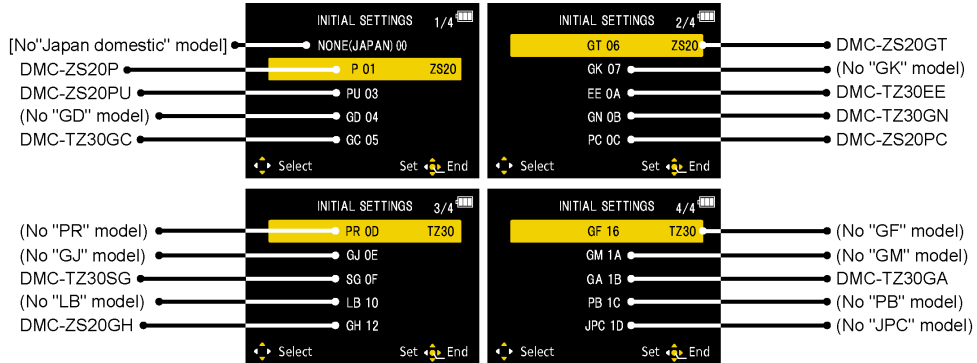

[Only for "DMC-TZ30EG, EF, EB, EP and TZ31EG" models : (VEP56159B is used as a Main P.C.B.)]

When Main P.C.B. has just been replaced, the following model suffix are displayed as follows. (Two pages in total)

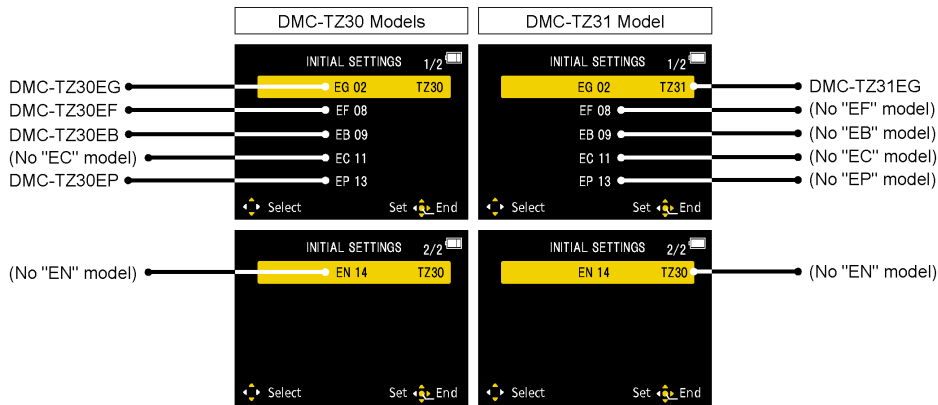

To display the "TZ31" model suffix, choose the "EG" area and press the DELETE button.

[Only for "DMC-TZ27EB and EC" models : (VEP56159C is used as a Main P.C.B.)]

When Main P.C.B. has just been replaced, the following model suffix are displayed as follows. (Two pages in total)

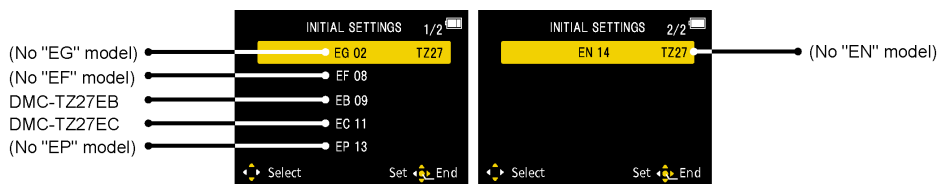

[Only for "DMC-ZS19P and ZS20GK" models : (VEP56159D is used as a Main P.C.B.)]

When Main P.C.B. has been replaced, the following model suffix are displayed as follows. (Four pages in total)

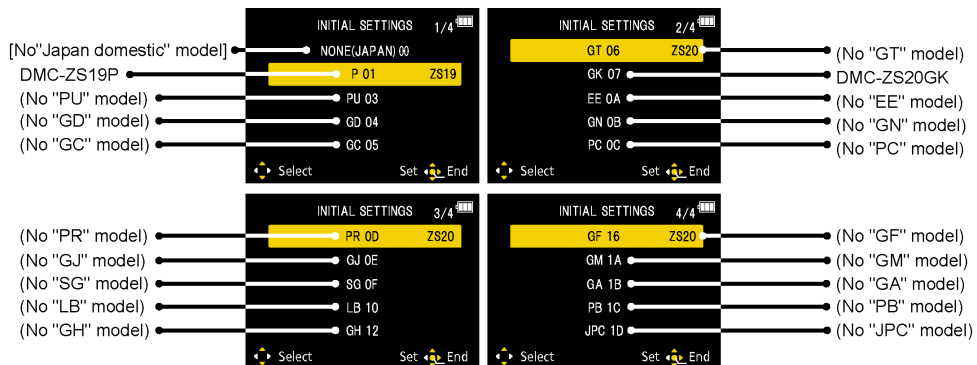

[CASE 2. Other than "After replacing Main P.C.B."]

< Other than "EG/EF/EB/EC and EP" models >

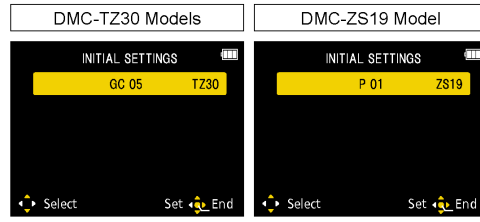

< Only "EG/EF/EB/EC and EP" models >

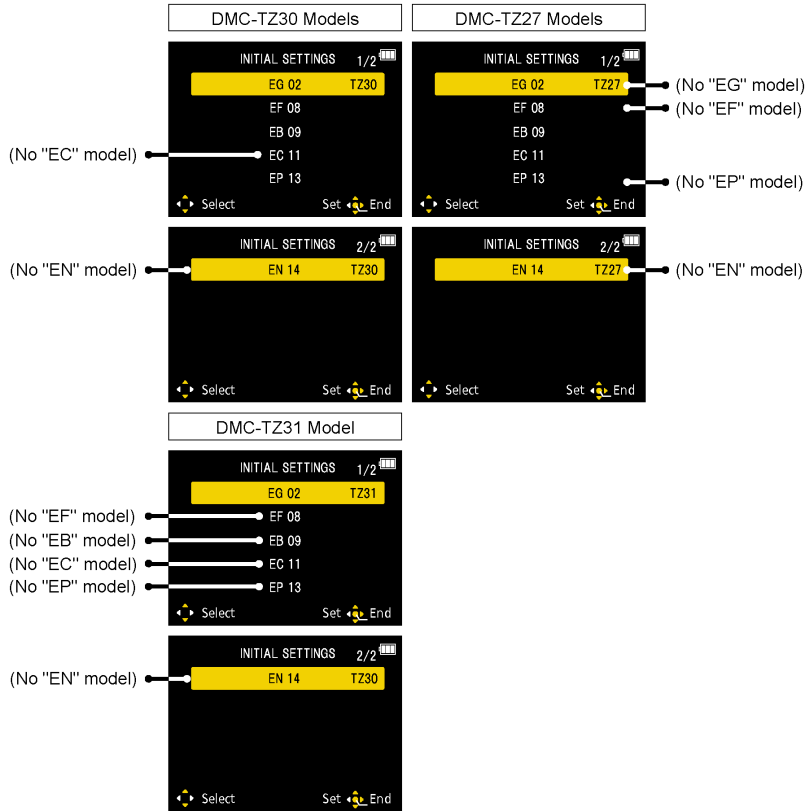

• **Step 5. Chose the model suffix in "INITIAL SETTINGS": (Refer to "CAUTION 1")**

[Caution: After replacing Main P.C.B.]

(Especially, other than "DMC-TZ30EG/EF/EB/EP, TZ31EG and DMC-TZ27EB/EC" models : (VEP56159A/D is used as a Main P.C.B.))

The model suffix can be chosen, JUST ONE TIME.

Once one of the model suffix have been chosen, the model suffix lists will not be displayed, thus, it can not be changed.

Therefore, select the area carefully.

Select the area with pressing "UP / DOWN of Cursor buttons".

• **Step 6. Set the model suffix at "INITIAL SETTINGS":**

Press the "RIGHT" of Cursor buttons".

The only set area is displayed. Press the "RIGHT" of Cursor buttons" after confirmation.

(The unit is powered off automatically.)

• **Step 7. CONFIRMATION:**

Confirm the display of "PLEASE SET THE CLOCK" in concerned language when the unit is turned on again.

When the unit is connected to PC with USB cable, it is detected as removable media.

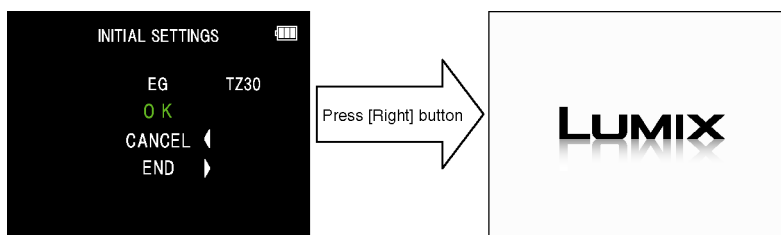

1) As for your reference, major default setting condition is as shown in the following table.

Default setting (After "INITIAL SETTINGS")

	MODEL	VIDEO OUTPUT	LANGUAGE	DATE	REMARKS
a)	DMC-TZ30 (Japan domestic model)	NTSC	Japanese	Year/Month/Date	
b)	DMC-TZ27EB	PAL	English	Date/Month/Year	
c)	DMC-TZ27EC	PAL	English	Date/Month/Year	
d)	DMC-TZ30EB	PAL	English	Date/Month/Year	
e)	DMC-TZ30EE	PAL	Russian	Date/Month/Year	
f)	DMC-TZ30EF	PAL	French	Date/Month/Year	
g)	DMC-TZ30EG	PAL	English	Date/Month/Year	
h)	DMC-TZ30EP	PAL	English	Date/Month/Year	
i)	DMC-TZ30GA	PAL	English	Date/Month/Year	
j)	DMC-TZ30GC	PAL	English	Date/Month/Year	
k)	DMC-TZ30GN	PAL	English	Date/Month/Year	
l)	DMC-TZ30SG	PAL	English	Date/Month/Year	
m)	DMC-TZ31EG	PAL	English	Date/Month/Year	
n)	DMC-ZS19P	NTSC	English	Month/Date/Year	
o)	DMC-ZS20P	NTSC	English	Month/Date/Year	
p)	DMC-ZS20PC	NTSC	English	Month/Date/Year	
q)	DMC-ZS20PU	NTSC	Spanish	Month/Date/Year	
r)	DMC-ZS20GH	PAL	English	Date/Month/Year	
s)	DMC-ZS20GK	PAL	Chinese (simplified)	Year/Month/Date	No Underwater mode.
t)	DMC-ZS20GT	NTSC	Chinese (Traditional)	Year/Month/Date	

4 Specifications

Digital Camera: Information for your safety

Power Source	DC 5.1 V
Power Consumption	When recording: 1.4 W When playing back: 1.1 W
Camera effective pixels	14,100,000 pixels
Image sensor	1/2.33" MOS sensor, total pixel number 15,300,000 pixels Primary color filter
Lens [NANO SURFACE COATING]	Optical 20 x zoom f=4.3 mm to 86.0 mm (35 mm film camera equivalent: 24 mm to 480 mm) / F3.3 (Max. W) to F6.4 (Max. T)
Image Stabilizer	Optical method
Focus range	
P / A / S / M	50 cm (1.6 feet) (Wide) / 2 m (6.6 feet) (Tele) to ∞
Macro / Intelligent Auto / Motion picture	3 cm (0.098 feet) (Wide) / 1 m (3.3 feet) (Tele) to ∞ (5 × to 7 × is 2 m (6.6 feet) to ∞)
Scene Mode	There may be difference in above settings.
Shutter system	Electronic shutter + Mechanical shutter
Minimum Illumination	Approx. 10 lx (when i-Low light is used, the shutter speed is 1/30th of a second)
Shutter speed	15 seconds to 1/2000th of a second
Exposure (AE)	Program AE (P) / Aperture-priority AE (A) / Shutter-priority AE (S) / Manual exposure (M)
Metering Mode	[Multi Metering] / [Center Weighted] / [Spot]

LCD monitor	3.0" TFT LCD (4:3) (Approx. 460,800 dots) (field of view ratio about 100%) / Touch screen
Microphone	Stereo
Speaker	Monaural
Recording media	Built-in Memory (Approx. 12 MB) SD Memory Card / SDHC Memory Card / SDXC Memory Card
Recording file format	
Still picture	JPEG (based on Design rule for Camera File system, based on Exif 2.3 standard / DPOF corresponding) / MPO
Motion pictures	AVCHD / MP4 / QuickTime Motion JPEG
Audio compression format	AVCHD: Dolby Digital (2 ch) MP4: AAC (2 ch)
Interface	
Digital	USB 2.0 (High Speed)
Analog video	NTSC Composite
Audio	Audio line output (Monaural)
Terminal	HDMI: MiniHDMI TypeC AV OUT/DIGITAL: Dedicated jack (8 pin)
Dimensions	Approx. 104.9 mm (W) x 58.9 mm (H) x 28.2 mm (D) [4.13" (W) x 2.32" (H) x 1.11" (D)] (excluding the projection part)
Mass (Weight)	With card and battery: Approx. 206 g (0.454 lb) Excluding card and battery: Approx. 184 g (0.406 lb)
Operating temperature	0 °C to 40 °C (32 °F to 104 °F)
Operating humidity	10%RH to 80%RH

AC adaptor
(Panasonic VSK0768): Information for your safety

Input	~ 110 V to 240 V, 50/60 Hz, 0.2 A
Output	== 5 V, 800 mA

Battery pack (lithium-ion)
(Panasonic DMW-BCG10PP): Information for your safety

Voltage / capacity	3.6 V / 895 mAh
---------------------------	-----------------

Note:

*Above specification is for DMC-ZS20P. Some of the specification may differ depends on model suffix.

[1] Only for "EB/EF/EG/EP" models:

1). [Interface Digital:]

- Data form the PC can not be written to the camera using the USB connection cable.

[2] Others:

1). [Analog video/audio:]

NTSC -----(Only "P/PC/PU/GT/GD" models)

NTSC/PAL Composite (Switched by menu) -----(Except "P/PC/PU/GT/GD" models)

2). [GPS:]

- DMC-TZ27EB/EC, ZS19P and ZS20GK do not equipped with GPS function.

5 Location of Controls and Components

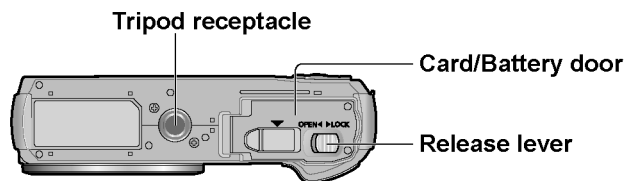
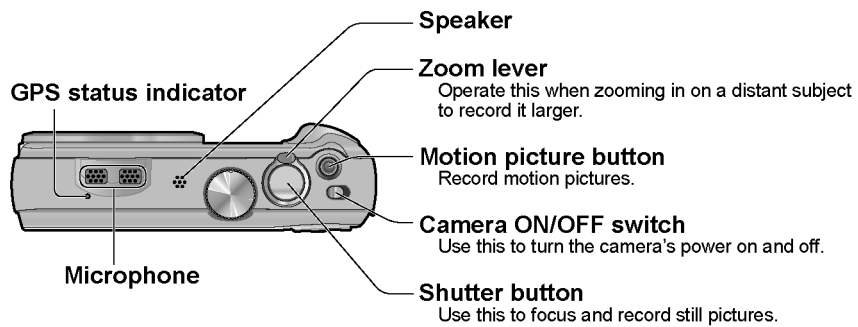
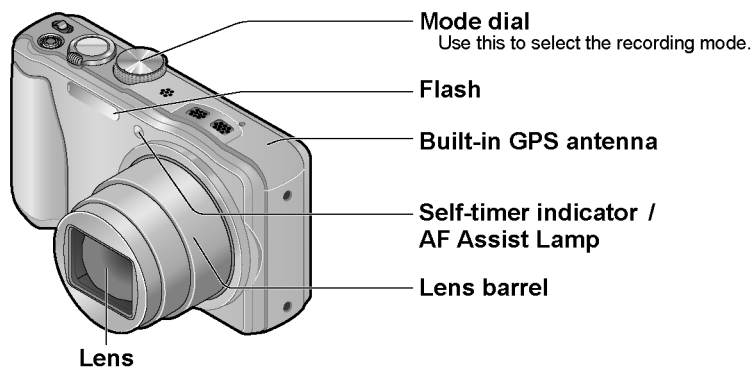

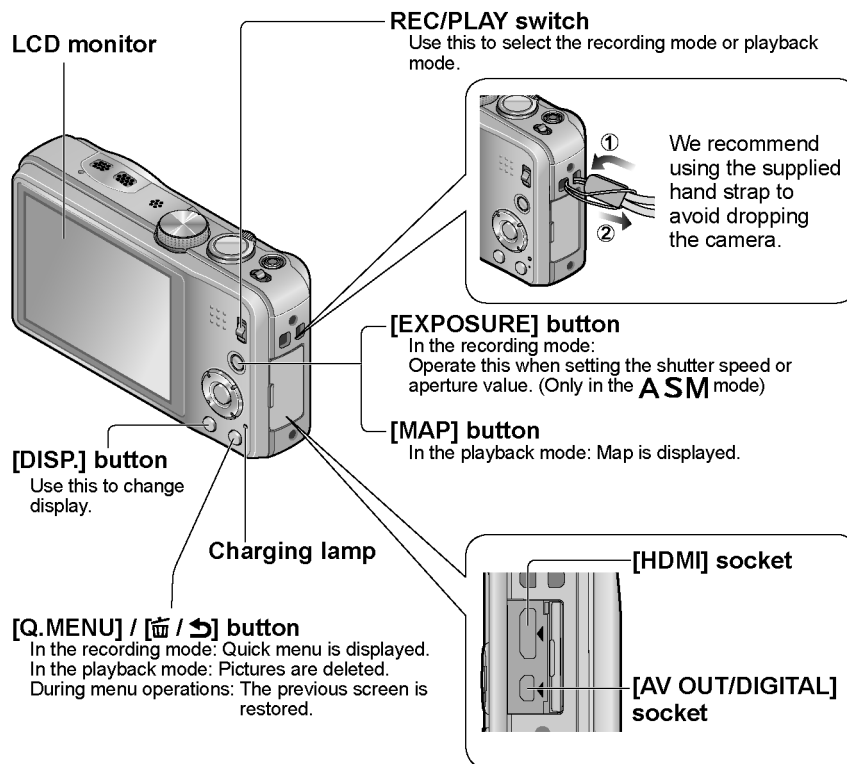

Cursor button

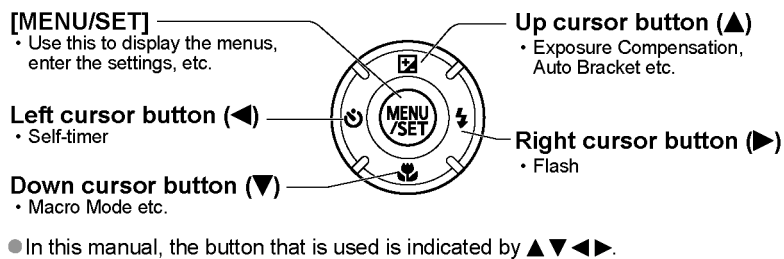

● The illustrations and screens in this manual may differ from the actual product.

Mode dial

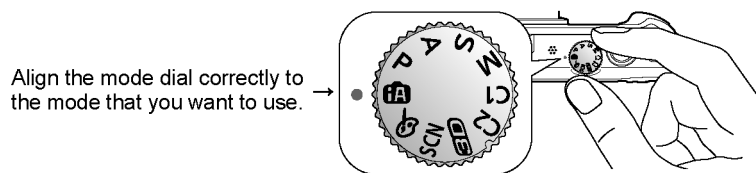

IA	[Intelligent Auto] Mode	Take pictures with automatic settings.
P	[Program AE] Mode	Record pictures with your own settings.
A	[Aperture-Priority] Mode	Determine aperture, then record pictures.
S	[Shutter-Priority] Mode	Determine shutter speed, then record pictures.
M	[Manual Exposure] Mode	Determine aperture and shutter speed, then record pictures.
C1 C2	[Custom] Mode	Record pictures using pre-registered settings.
3D	[3D Photo Mode]	Record 3D still pictures.
SCN	[Scene Mode]	Take pictures according to scene.
CC	[Creative Control] Mode	Take pictures while confirming the picture effect.

6 Service Mode

6.1. Error Code Memory Function

1. General description

This unit is equipped with history of error code memory function, and can be memorized 16 error codes in sequence from the latest. When the error is occurred more than 16, the oldest error is overwritten in sequence.

The error code is not memorized when the power supply is shut down forcibly (i.e., when the unit is powered on by the battery, the battery is pulled out) The error code is memorized to Flash ROM when the unit has just before powered off.

2. How to display

The error code can be displayed by ordering the following procedure:

• Preparation:

1. Attach the Battery to the unit.
2. Set the mode dial to the PROGRAM AE mode.

Note:

*Since this unit has built-in memory, it can be performed without inserting SD memory card.

• Step 1. The temporary cancellation of "INITIAL SETTINGS":

Set the REC/PLAYBACK selector switch to "REC (Camera mark)".

While keep pressing "UP of Cursor button" and MOTION PICTURE button simultaneously, turn the Power SW on.

• Step 2. Execute the error code display mode:

Press the "LEFT of Cursor button", MENU/SET button and MOTION PICTURE button simultaneously.

The display is changed as shown below when the above buttons are pressed simultaneously.

Normal display → Error code display → CAMERA INFO → Normal display →

Example of Error Code Display

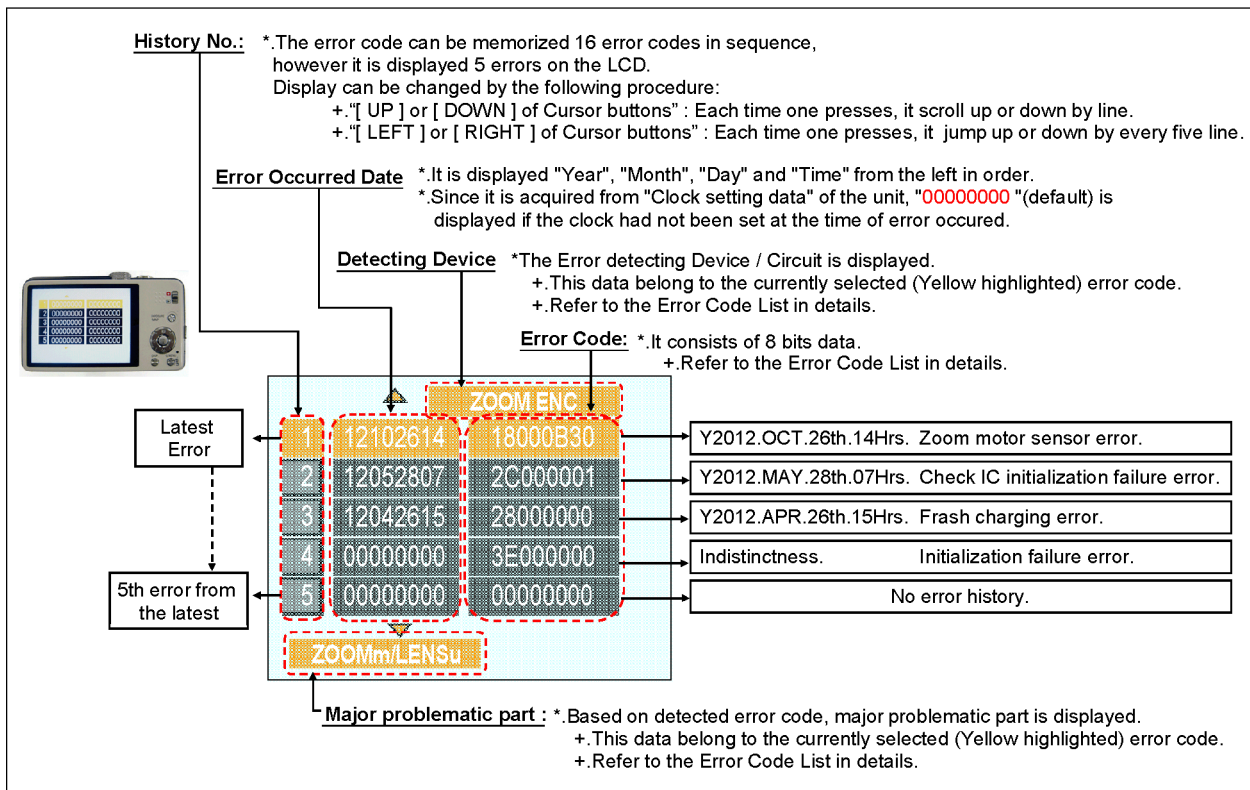

3. Error Code List

The error code consists of 8 bits data and it shows the following information.

Attribute	Main item	Sub item	Error code		Contents (Upper)	Error Indication	
			High 4bits	Low 4 bits	Check point (Lower)	Detecting device	Part/Circuit
LENS	Lens drive	OIS	18*0	1000	PSD (X) error. Hall element (X axis) position detect error in OIS unit. OIS Unit	OIS X	LENSu NG
				2000	PSD (Y) error. Hall element (Y axis) position detect error in OIS unit. OIS Unit	OIS Y	
			3000	GYRO (X) error. Gyro (IC7101) detect error on Main P.C.B. IC7101 (Gyro element) or IC6001 (VENUS ENGINE)	GYRO X	GYRO NG	
				4000	GYRO (Y) error. Gyro (IC7101) detect error on Main P.C.B. IC7101 (Gyro element) or IC6001 (VENUS ENGINE)		GYRO Y
			5000	MREF error (Reference voltage error). IC9101 (LENS drive) or IC6001 (VENUS ENGINE)	OIS REF	LENSSd/DSP NG	
				6000	Drive voltage (X) error. LENS Unit, LENS flex breaks, IC6001(VENUS ENGINE) AD value error, etc.		OISX REF
			7000	Drive voltage (Y) error. LENS Unit, LENS flex breaks, IC6001(VENUS ENGINE) AD value error, etc.	OISY REF		
			Zoom (C.B.)	0?10	Collapsible barrel Low detect error (Collapsible barrel encoder always detects High.) Mechanical lock, FP9005-(11) signal line or IC6001 (VENUS ENGINE)	ZOOM L	ZOOMm/LENSu
		0?20			Collapsible barrel High detect error (Collapsible barrel encoder always detects Low.) Mechanical lock, FP9005-(11) signal line or IC6001 (VENUS ENGINE)		
		0?30		Zoom motor sensor error. Mechanical lock, FP9005-(6), (9) signal line or IC6001 (VENUS ENGINE)	ZOOM ENC		
				0?40		Zoom motor sensor error. (During monitor mode.) Mechanical lock, FP9005-(6), (9) signal line or IC6001 (VENUS ENGINE)	
		0?50		Zoom motor sensor error. (During monitor mode with slow speed.) Mechanical lock, FP9005-(6), (9) signal line or IC6001 (VENUS ENGINE)			
				0?60	Phase error or operation failure of zoom Lens/motor/encoder. (IMPACT) Mechanical lock, zoom encoder.		
		Focus		0?01	HP High detect error (Focus encoder always detects High, and not becomes Low) Mechanical lock, FP9005-(11) signal line or IC6001 (VENUS ENGINE)	FOCUS L	LENS FPC/DSP
					0?02	HP Low detect error (Focus encoder always detects Low, and not becomes High) Mechanical lock, FP9005-(11) signal line or IC6001 (VENUS ENGINE)	
		Lens	18*1	0000	Power ON time out error. Lens drive system	LENS DRV	LENSu
				18*2	0000		

Attribute	Main item	Sub item	Error code		Contents (Upper)	Error Indication		
			High 4bits	Low 4 bits	Check point (Lower)	Detecting device	Part/Circuit	
	Adj.History	OIS	19*0	2000	OIS adj. Yaw direction amplitude error (small)	OIS ADJ	OIS ADJ	
				3000	OIS adj. Pitch direction amplitude error (small)			
				4000	OIS adj. Yaw direction amplitude error (large)			
				5000	OIS adj. Pitch direction amplitude error (large)			
				6000	OIS adj. MREF error			
				7000	OIS adj. time out error			
				8000	OIS adj. Yaw direction off set error			
				9000	OIS adj. Pitch direction off set error			
				A000	OIS adj. Yaw direction gain error			
				B000	OIS adj. Pitch direction gain error			
				C000	OIS adj. Yaw direction position sensor error			
				D000	OIS adj. Pitch direction position sensor error			
				E000	OIS adj. other error			
HARD	VENUS A/D	Flash	28*0	0000	Flash charging error. IC6001-(AC18) signal line or Flash charging circuit	STRB CHG	STRB PCB/ FPC	
	FLASH ROM (EEPROM Area)	FLASH ROM (EEPROM Area)	2B*0	0001	EEPROM read error	FROM RE	FROM	
				0003	IC6001 (Flash ROM)	FROM WR	FROM	
				0004	EEPROM write error			
				0002	IC6001 (Flash ROM)			
				0005	Firmware version up error Replace the firmware file in the SD memory card.	(No indication)	(No indication)	
	0008	SDRAM error	(No indication)	(No indication)				
	0009	SDRAM Mounting defective						
	SYSTEM	RTC	2C*0	0001	SYSTEM IC initialize failure error Communication between IC6001 (VENUS ENGINE) and IC9101 (SYSTEM)	SYS INIT	MAIN PCB	
	SOFT	CPU	Reset	30*0	0001 0007	NMI reset Non Mask-able Interrupt (30000001-30000007 are caused by factors)	NMI RST	MAIN PCB
Card		Card	31*0	0001	Card logic error SD memory card data line or IC6001 (VENUS ENGINE)	SD CARD	SD CARD/ DSP	
				0002	Card physical error SD memory card data line or IC6001 (VENUS ENGINE)			
				0004	Write error SD memory card data line or IC6001 (VENUS ENGINE)			
				39*0	0005	Format error	INMEMORY	FROM
				CPU, ASIC hard	Stop	38*0	0001	Camera task finish process time out. Communication between Lens system and IC6001 (VENUS ENGINE)
0002		Camera task invalid code error. IC6001 (VENUS ENGINE)	DSP	DSP				
0100		File time out error in recording motion image IC6001 (VENUS ENGINE)	INIT	(No indication)				
0200		File data cue send error in recording motion image IC6001 (VENUS ENGINE)						
0300		Single or burst recording brake time out.						
Memory area		3A*0	0008	work area partitioning failure USB dynamic memory securing failure when connecting			(No indication)	(No indication)
			0000	Flash ROM processing early period of camera during movement.	INIT	(No indication)		
Operation		Power on	3B*0	0000	Flash ROM processing early period of camera during movement.	INIT	(No indication)	
Zoom		Zoom	3C*0	0000	Imperfect zoom lens processing Zoom lens	ZOOM	ZOOMm/ LENSu	
				35*0	0000 FFFF	Software error (0-7bit : command, 8-15bit : status)	DSP	DSP
	35*1		0000	Though record preprocessing is necessary, it is not called.	(No indication)	(No indication)		
	35*2		0000	Though record preprocessing is necessary, it is not completed.				

Important notice about "Error Code List"

1) About "*" indication:

The third digit from the left is different as follows.

+In case of 0 (example: 18 **0** 01000)

When the third digit from the left shows "0", this error occurred under the condition of INITIAL SETTINGS has been completed.
It means that this error is occurred basically at user side.

+In case of 8 (example: 18 **8** 01000)

When the third digit from the left shows "8", this error occurred under the condition of INITIAL SETTINGS has been released.
(Example; Factory assembling-line before unit shipment, Service mode etc.)
It means that this error is occurred at service side.

2) About "?" indication: ("18*0 0?01" to "18*0 0?50"):

The third digit from the right shows one of the hexadecimal ("0" to "F") character.

4. How to exit from Error Code display mode:

Simply, turn the power off. (Since Error code display mode is executed under the condition of temporary cancellation of "INITIAL SETTINGS", it wake up with normal condition when turn off the power.)

Note:

The error code can not be initialized.

7 Troubleshooting Guide

7.1. Checking Method of GPS failure (Except: TZ27EB/EC, ZS19P and 20GK)

1. GENERAL DESCRIPTION

- **When [GPS Setting] is [ON], the GPS function works even if the camera's power is off.**
 - Electromagnetic waves from the camera can affect instruments and meters. During takeoff and landing of airplanes or in other restricted areas, set [GPS Setting] to [OFF] or set [Airplane Mode] to [ON], and then turn off the camera.
 - When [GPS Setting] is [ON] and [Airplane Mode] is [OFF], power will drain from the battery even if the camera is turned OFF.
- **Recording location information**
 - The names of recording locations and landmarks (such as buildings) are current as of December 2011. These will not be updated.
 - Depending on the country or area, limited location name and landmark information may be available.
- **Positioning**
 - Positioning will take time in environments where it is difficult to receive the signals from the GPS satellites.
 - **Even if GPS reception is good, it will take approx. 2 to 3 minutes to successfully execute positioning under the following conditions: when positioning is executed for the first time, or when positioning is executed after the camera is turned off with the [GPS Setting] set to [OFF] or [Airplane Mode] set to [ON], and then turned on again. Positioning can be executed faster using GPS assist data.**
 - Because the positions of the GPS satellites are constantly changing, depending on the recording location and conditions, it may not be possible to position such satellites accurately, or positioning discrepancy may occur.
- **When using in another country**
 - GPS may not work in China or in the border regions of countries neighboring China. (Current as of December 2011)
 - Some countries or regions may regulate the use of GPS or related technology. Because this camera has a GPS function, before taking it into another country, check with the embassy or your travel agency whether there are any restrictions on bringing cameras with a GPS function.

Note:
DMC-TZ27EB/EC, ZS19P and ZS20GK do not equipped with GPS function.

2. Checking flowchart of GPS failure.

The checking flowchart of GPS failure is as follows:

Note:

*Perform the GPS communication test, even if the repair being carried out is not related with GPS function.



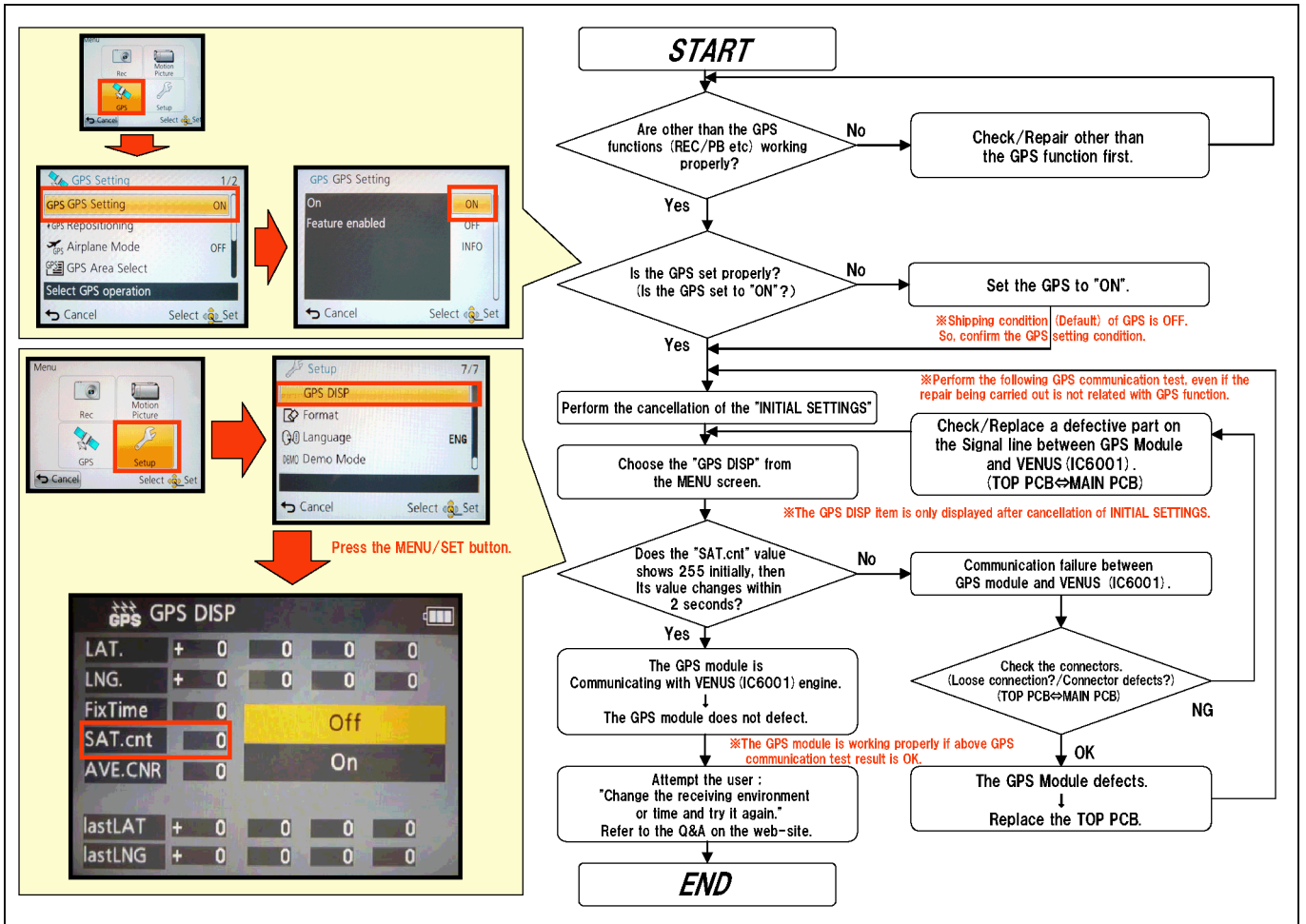



*The GPS function in this unit is performed communication between GPS P.C.B. (on the Top P.C.B.) and VENUS ENGINE (IC6001: on the Main P.C.B.).

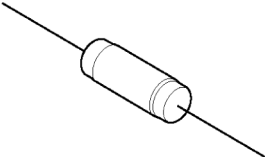
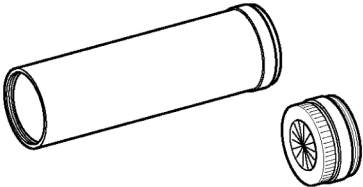
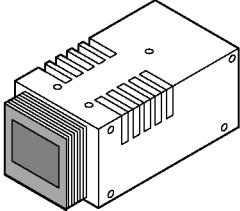
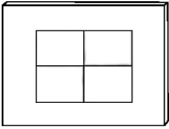

8 Service Fixture & Tools

8.1. Service Fixture and Tools

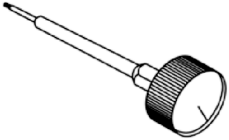
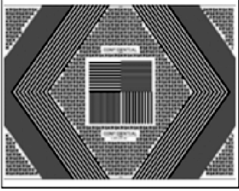
The following Service Fixture and tools are used for checking and servicing this unit.

Resistor for Discharging ERG5SJ102	COLLIMATOR (with Focus Chart) RFKZ0422	LIGHT BOX (with DC Cable) RFKZ0523
 <p>An equivalent type of Resistor may be used.</p>		 <p>※ VFK1164TDVLB may be used.</p>
TR Chart RFKZ0443	Lens Cleaning Kit (BK) VFK1900BK	Screw locking glue RFKZ0573
	 <p>* Only supplied as 10 set/box.</p>	
Diffuser RFKZ0591	Driver (for optical axis adjustment) RFKZ0569	Optical axis adjustment chart RFKZ0570
		
Camera stand RFKZ0333J	Touch Pen Goods on market	
	 <p>* VGQ0C14 (Example)</p>	

8.2. When Replacing the Main P.C.B.

After replacing the Main P.C.B., be sure to achieve adjustment.

The Maintenance software (DIAS) is available at "software download" on the "Support Information from NWBG/VDBG-AVC" web-site in "TSN system".

8.3. Service Position

This Service Position is used for checking and replacing parts. Use the following Extension cables for servicing.

No.	Parts No.	Connection	Form
1	VFK1895	PP9006 (MAIN P.C.B.) - PS9201 (OPERATION P.C.B.)	40PIN B to B
2	RFKZ0545	PP9901 (TOP P.C.B.) - PS9904 (Main P.C.B.)	34PIN B to B
3	VFK1906	PP8001 (FLASH P.C.B.) - PS9903 (TOP P.C.B.)	20PIN B to B

8.3.1. Extension Cable Connections

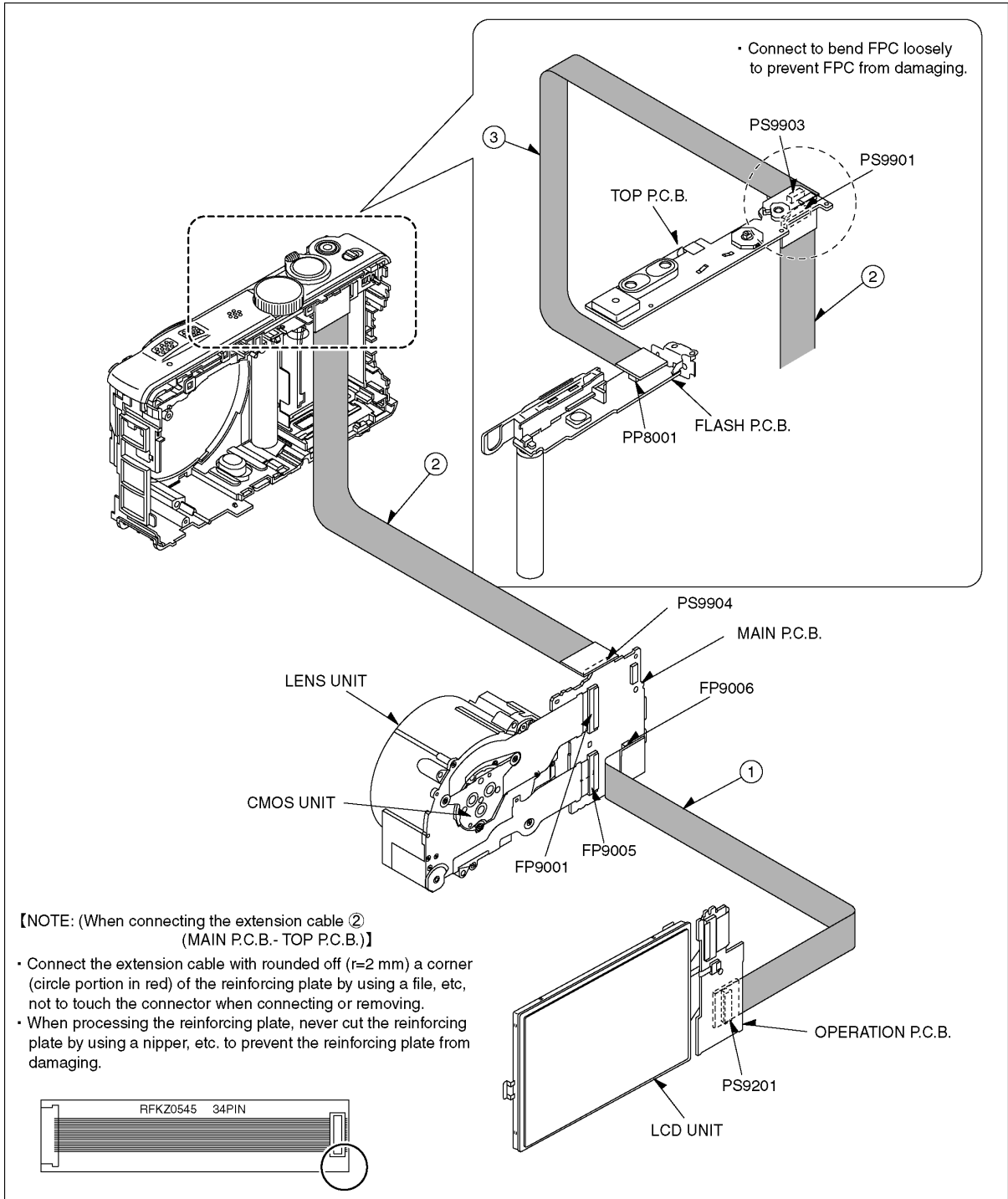

CAUTION-1. (When servicing Flash P.C.B.)

1. Be sure to discharge the capacitor on Flash P.C.B.
Refer to "HOW TO DISCHARGE THE CAPACITOR ON Flash P.C.B.". The capacitor voltage is not lowered soon even if the AC Cord is unplugged or the battery is removed.
2. Be careful of the high voltage circuit on Flash P.C.B.
3. DO NOT allow other parts to touch the high voltage circuit on Flash P.C.B.

9 Disassembly and Assembly Instructions

9.1. Disassembly Flow Chart

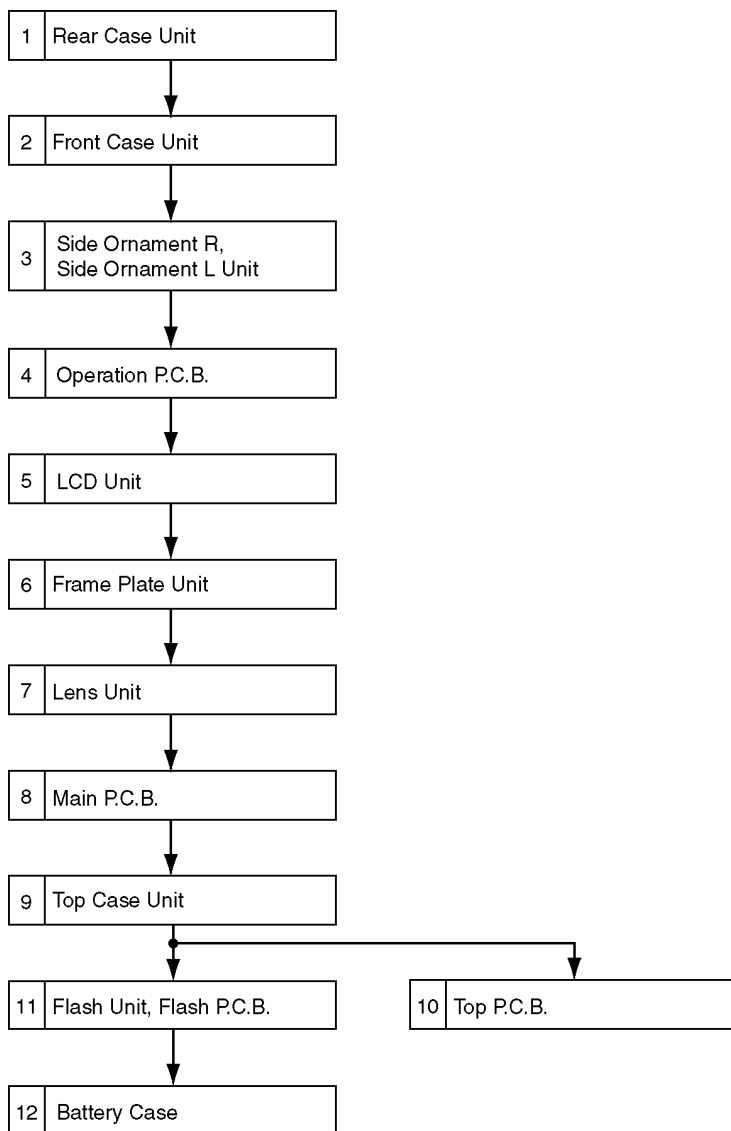

9.2. P.C.B. Location

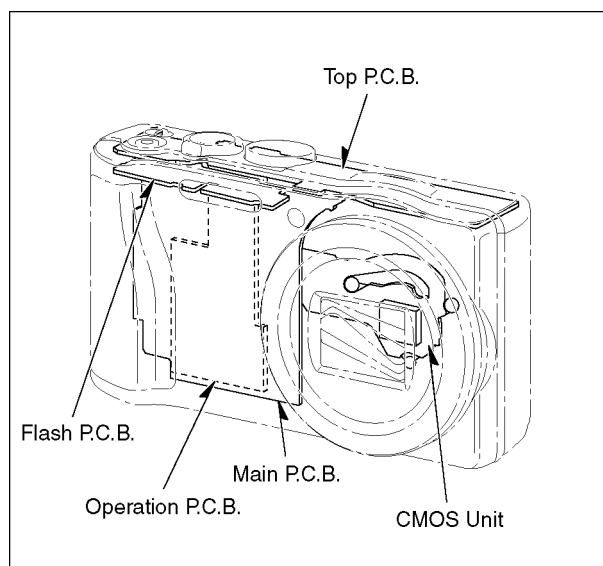

9.3. Disassembly Procedure

No.	Item	Fig.	Removal
1	Rear Case Unit	Fig. D1	4 screws (A)
			1 screw (B)
			Rear Case Unit
2	Front Case Unit	Fig. D2	1 screw (C)
			1 Locking tab
			Front Case Unit
3	Side Ornament R, Side Ornament L Unit	Fig. D3	Side Ornament R, Side Ornament L Unit
4	Operation P.C.B.	Fig. D4	FP9202 (Flex)
			FP9203 (Flex)
			PS9201 (Connector)
			Operation P.C.B.
			Note:(When replacing Operation P.C.B.) Operation Sheet
5	LCD Unit	Fig. D5	1 Locking tab
			LCD Unit
6	Frame Plate Unit	Fig. D6	3 screws (D)
			2 Locking tabs
			Frame Plate Unit
7	Lens Unit	Fig. D7	FP9001 (Flex)
			FP9005 (Flex)
			PCB Spacer
			2 FPC Tapes
			Lens Unit
8	Main P.C.B.	Fig. D8	1 screw (E)
			1 Locking tab
			DPR Sheet
			Main P.C.B.
9	Top Case Unit	Fig. D9	4 Locking tabs
			Top Case Unit
10	Top P.C.B.	Fig. D10	1 screw (F)
			2 Locking tabs (A)
			1 Locking tab (B)
			4 Locking tabs (C)
			FP9902 (Flex)
			Flash Spacer
			Earth Plate R
			Top P.C.B.
			Note:(When replacing Top P.C.B.) DPR Sheet (GPS) Top AF Sheet
11	Flash Unit, Flash P.C.B.	Fig. D12	3 Locking tabs
			Flash Unit, Flash P.C.B.
12	Battery Case	Fig. D13	3 Locking tabs (A)
			1 Locking tab (B)
			Battery Case

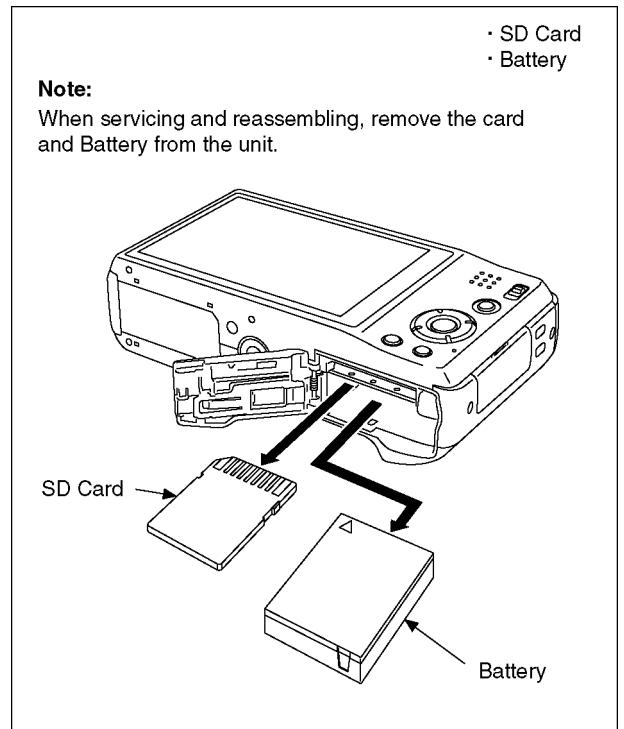

9.3.1. Removal of the Rear Case Unit

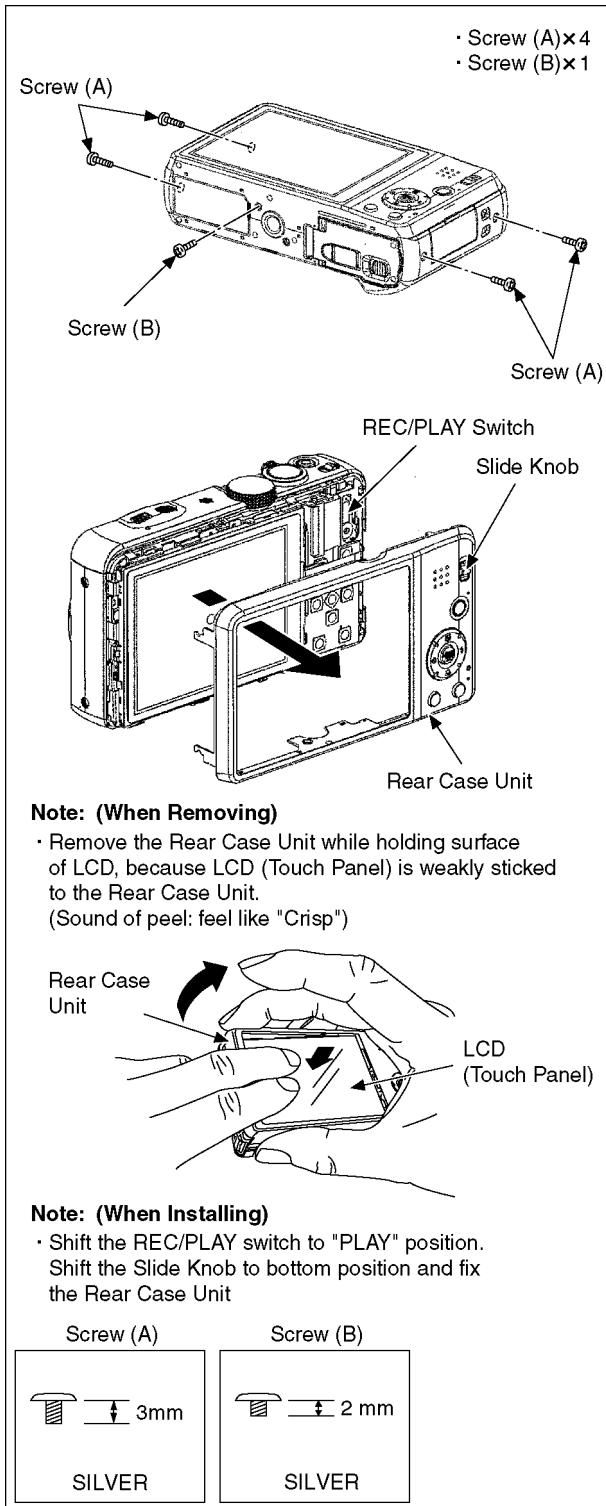

Fig. D1

9.3.2. Removal of the Front Case Unit

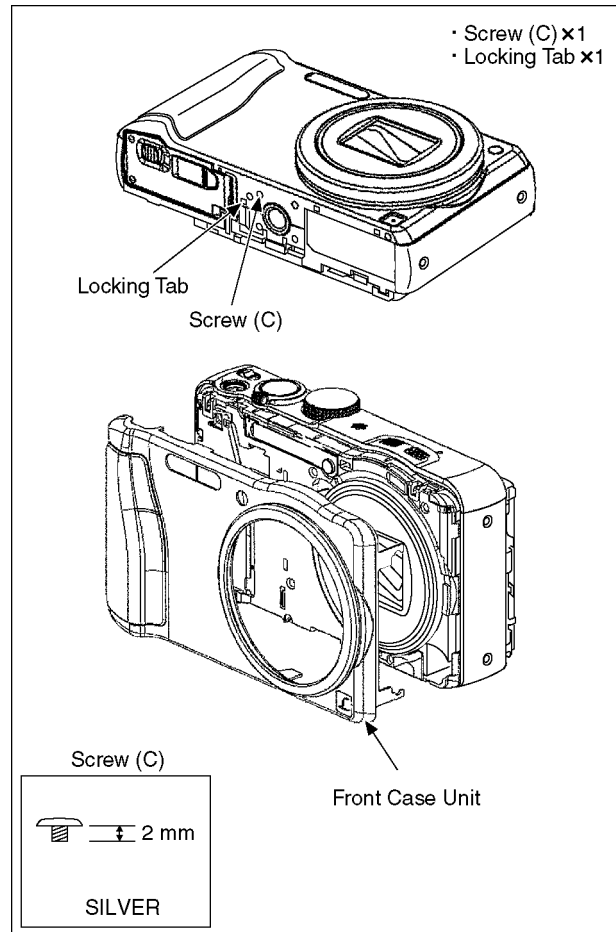

Fig. D2

9.3.3. Removal of the Side Ornament R, Side Ornament L Unit

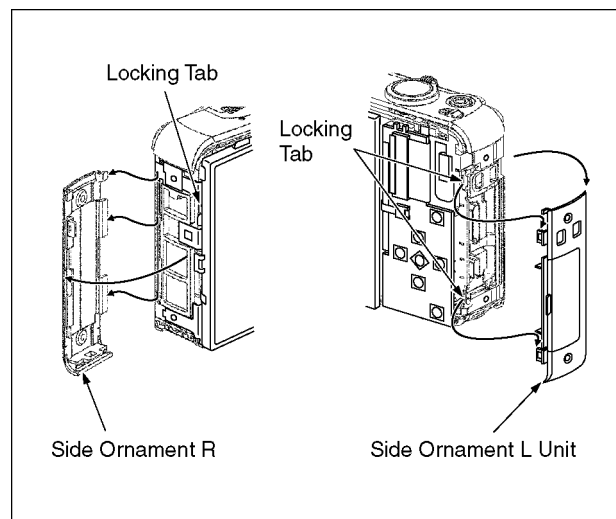

Fig. D3

9.3.4. Removal of the Operation P.C.B.

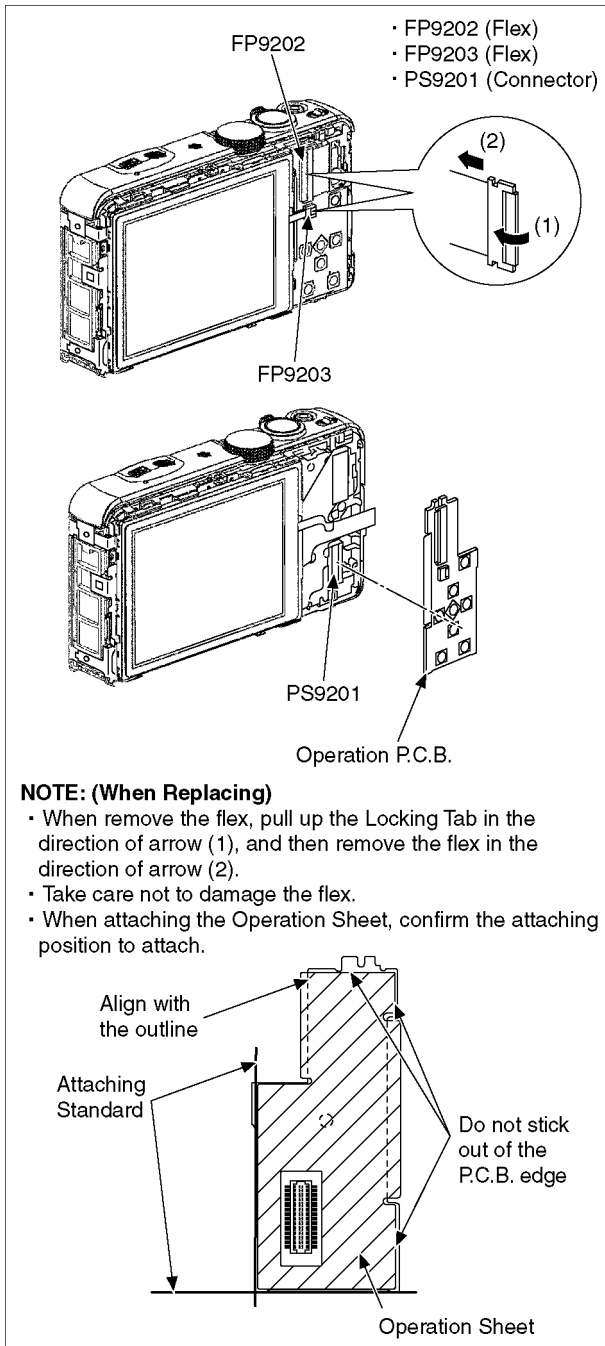

Fig. D4

9.3.5. Removal of the LCD Unit

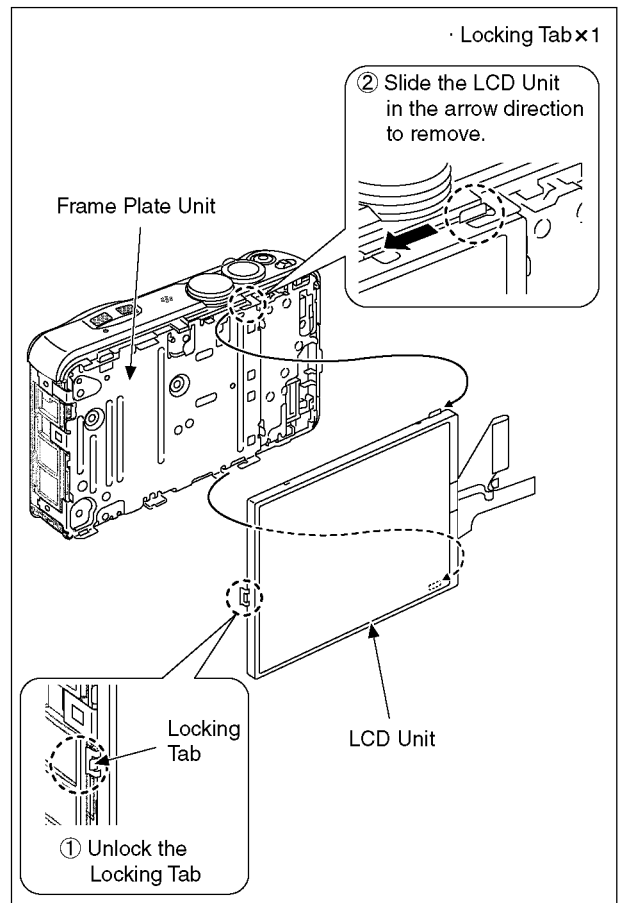

Fig. D5

9.3.6. Removal of the Frame Plate Unit

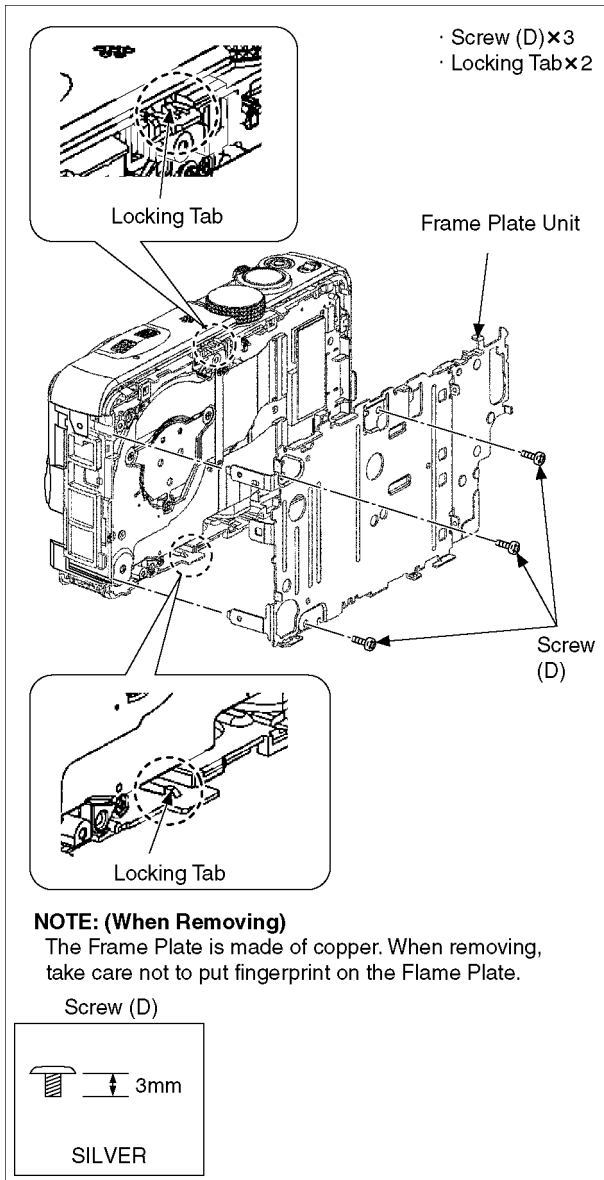

Fig. D6

9.3.7. Removal of the Lens Unit

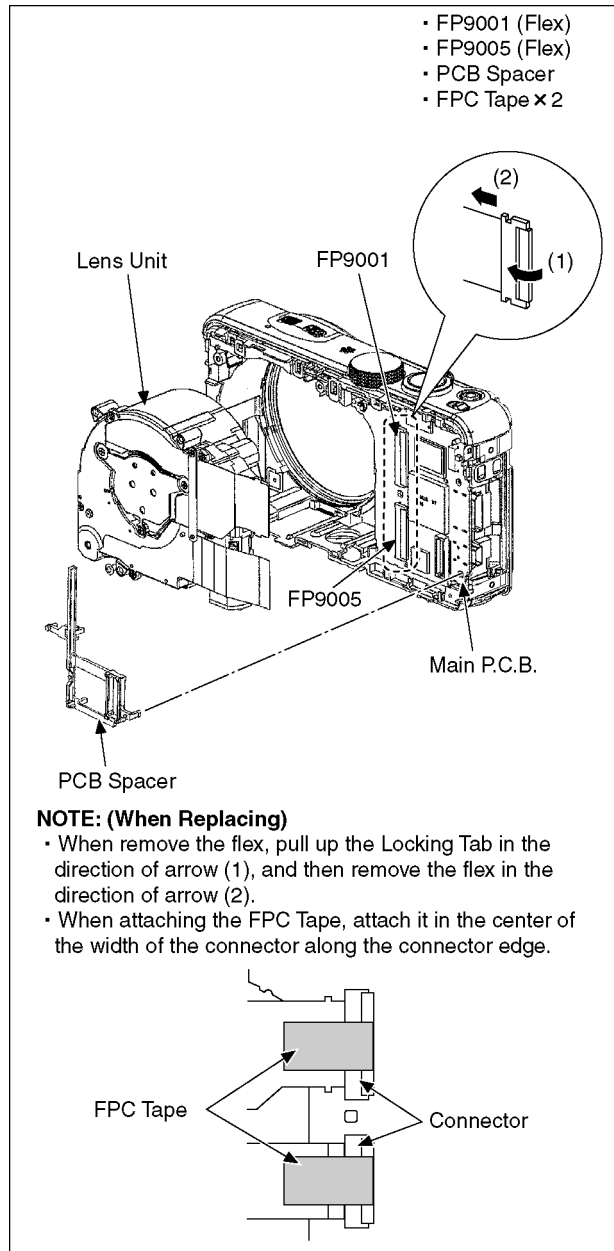

Fig. D7

9.3.8. Removal of the Main P.C.B.

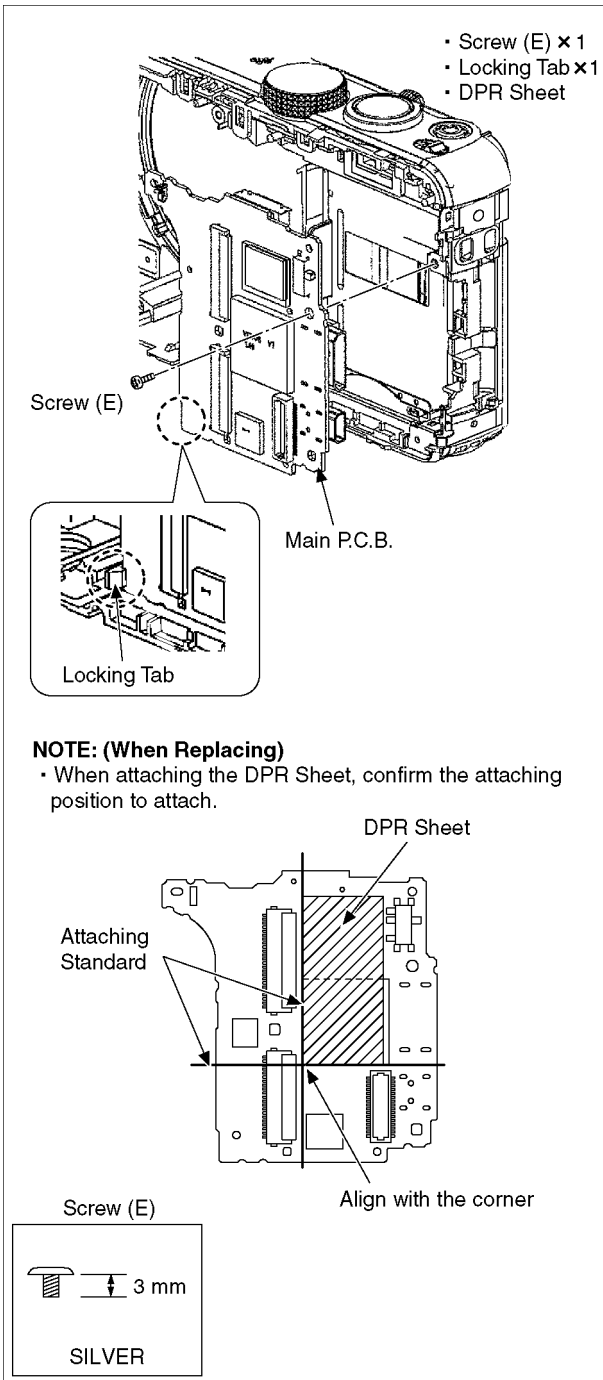

Fig. D8

9.3.9. Removal of the Top Case Unit

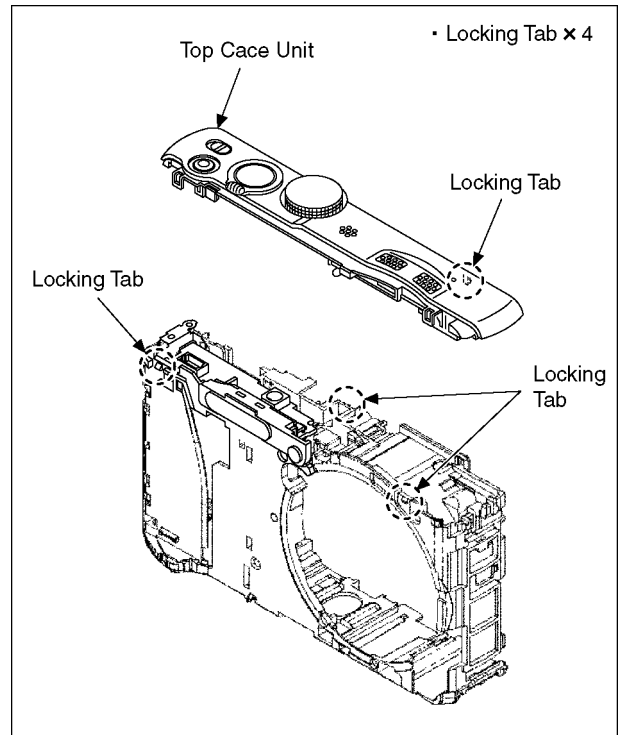
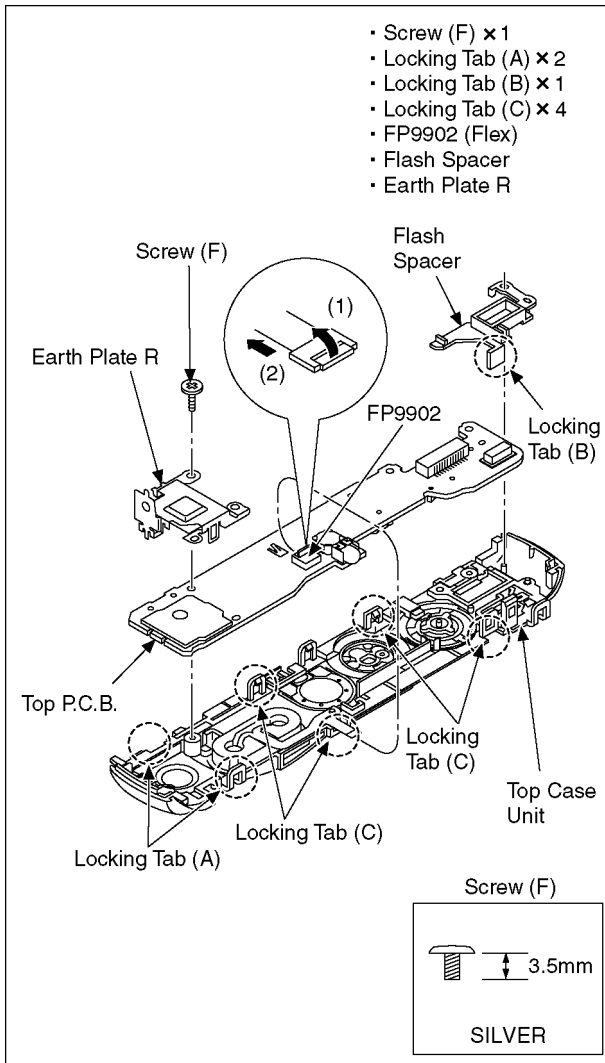

Fig. D9

9.3.10. Removal of the Top P.C.B.



NOTE: (When Replacing)

· When remove the flex, pull up the Locking Tab in the direction of arrow (1), and then remove the flex in the direction of arrow (2).

※ 1: Move the Power Knob to ON position and fix.

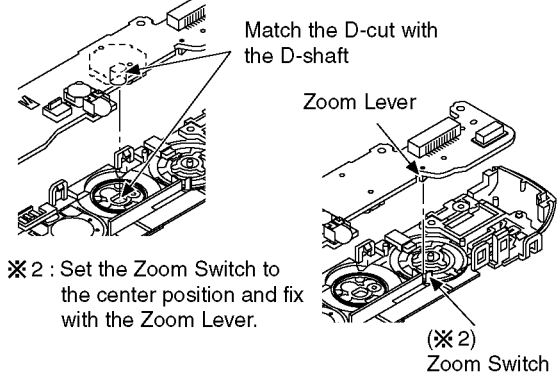

· When attaching the DPR Sheet (GPS) and the Top AF Sheet, confirm the attaching position to attach.

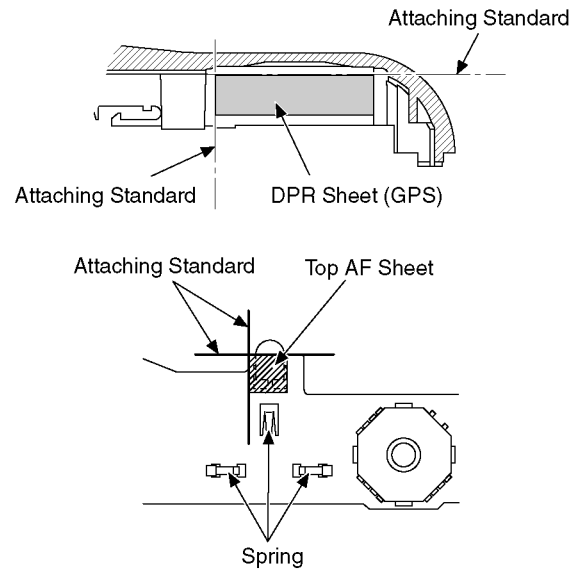

* Do not change the shape of the Spring.

Fig. D11

9.3.11. Removal of the Flash Unit, Flash P.C.B.

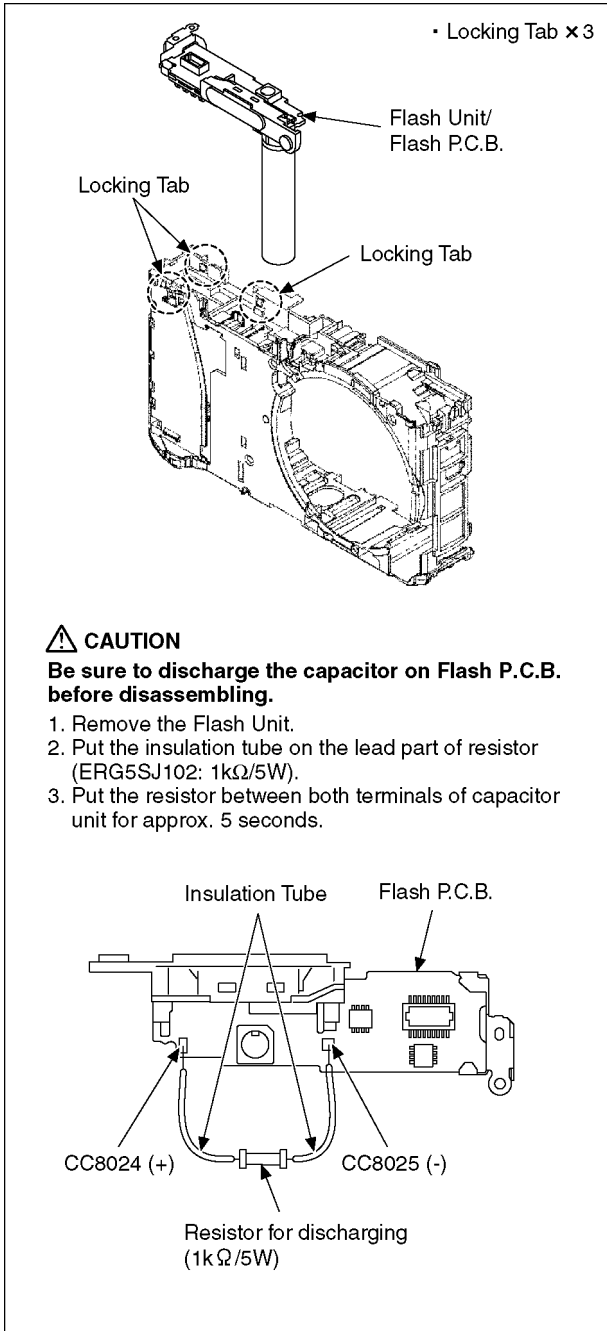

Fig. D12

9.3.12. Removal of the Battery Case

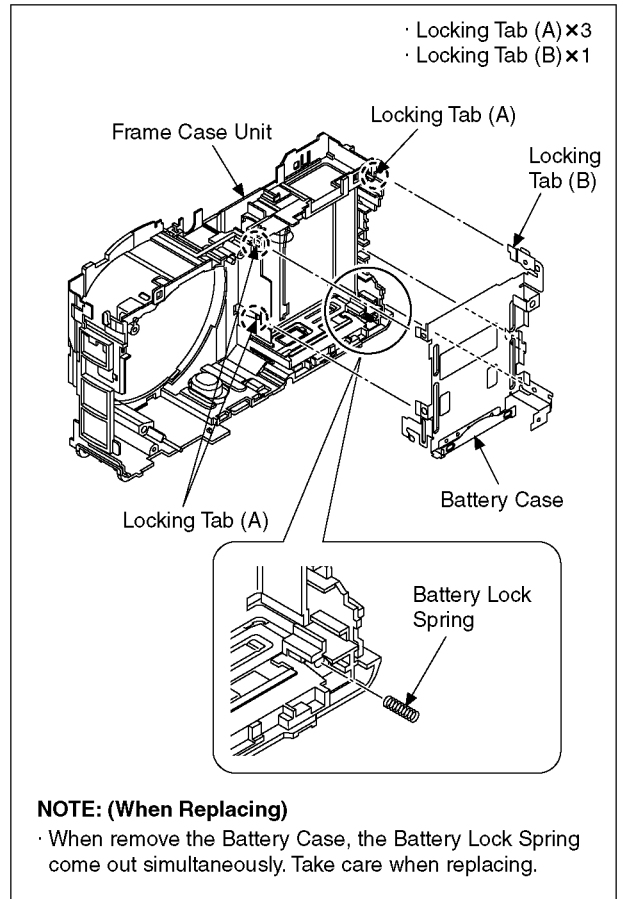

Fig. D13

9.4. Lens Disassembly Procedure

Precaution:

1. Do not remove the CMOS when disassembling or re-assembling the lens in order to maintain it clean.
When remove it, refer to item "9.6".
2. Keep dust or dirt away from the lens.
3. To remove dirt or dust from the lens, blow with dry air.
4. Do not touch the lens surface.
5. Use lens cleaning KIT (BK)(VFK1900BK).
6. Apply grease (RFKZ0472) as shown on "THE APPLICATION OF GREASE METHOD" in the figure.
7. Apply a light coat of grease using an object similar to a toothpick.

9.4.1. Removal of the Master Flange Unit

1. Unscrew the 6 screws (A).
2. Remove the Connector (20p).
3. Remove the Master Flange Unit and Drive Gear.

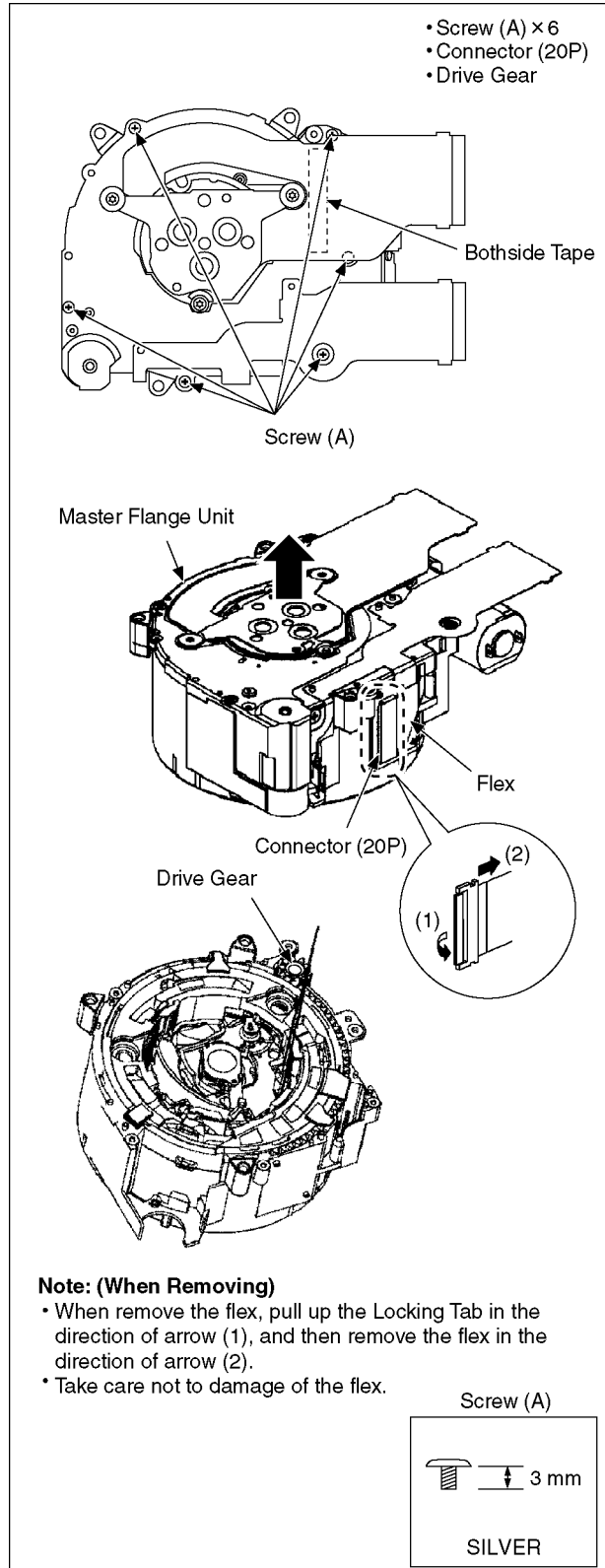

9.4.2. Removal of the Drive Frame Unit, Decorative Frame Unit, Outside Cam Frame, 1st Lens Frame Unit, 2nd Lens Frame Unit, 3rd Lens Frame Unit, Straight Frame and Both Side Cam Frame

1. Turn the Fix Cam Frame Unit in the arrow (1) direction, and align the Δ mark (Fix Cam Frame and Outside Cam Frame and Drive Frame).
2. Push the 1st Lens Frame Unit in the arrow (2) direction from the front of the Lens, and then remove the Unit of Drive Frame Unit, Decorative Frame Unit, Outside Cam Frame, 1st Lens Frame Unit, 2nd Lens Frame Unit, 3rd Lens Frame Unit, Straight Frame and Both Side Cam Frame from the Fix Cam Frame Unit.

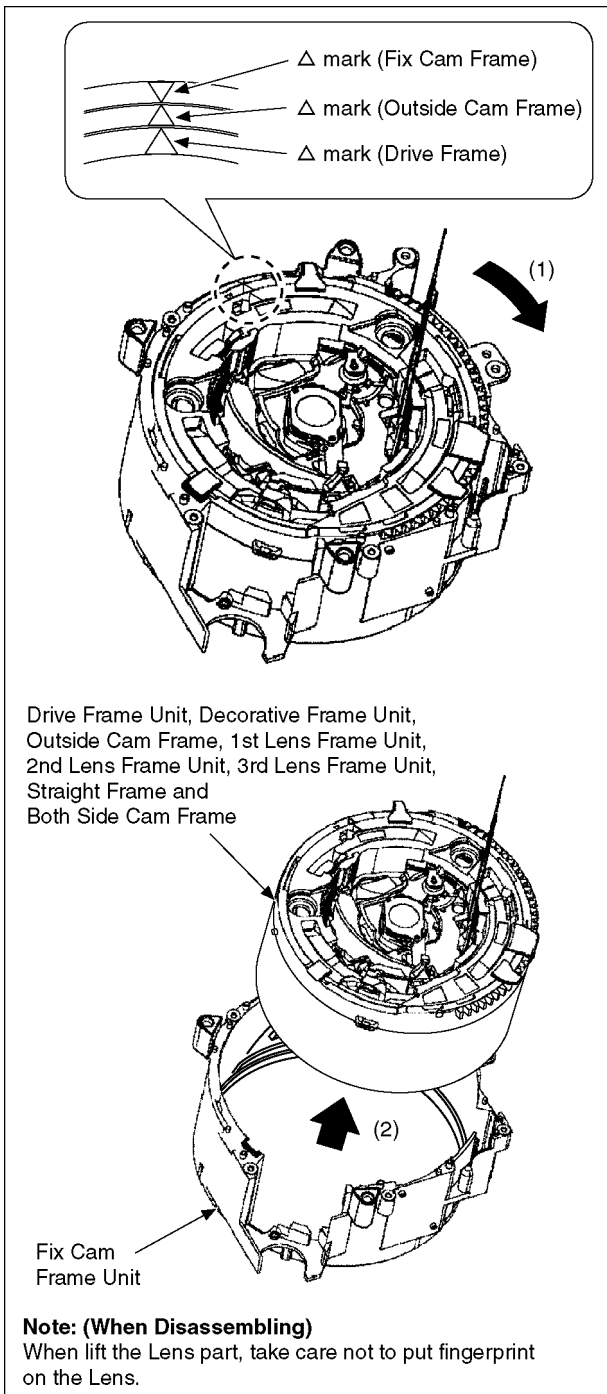

9.4.3. Removal of the Decorative Frame Unit, Outside Cam Frame, 1st Lens Frame Unit, 2nd Lens Frame Unit, 3rd Lens Frame Unit, Straight Frame and Both Side Cam Frame

1. Turn the Outside Cam Frame in the arrow (2) direction, and then align the Δ mark (Drive Frame and Outside Cam Frame).
2. Push the 1st Lens Frame Unit in the arrow (2) direction from the front of the Lens, and remove the Unit of Decorative Frame Unit, Outside Cam Frame, 1st Lens Frame Unit, 2nd Lens Frame Unit, 3rd Lens Frame Unit, Straight Frame and Both Side Cam Frame from the Drive Frame Unit.

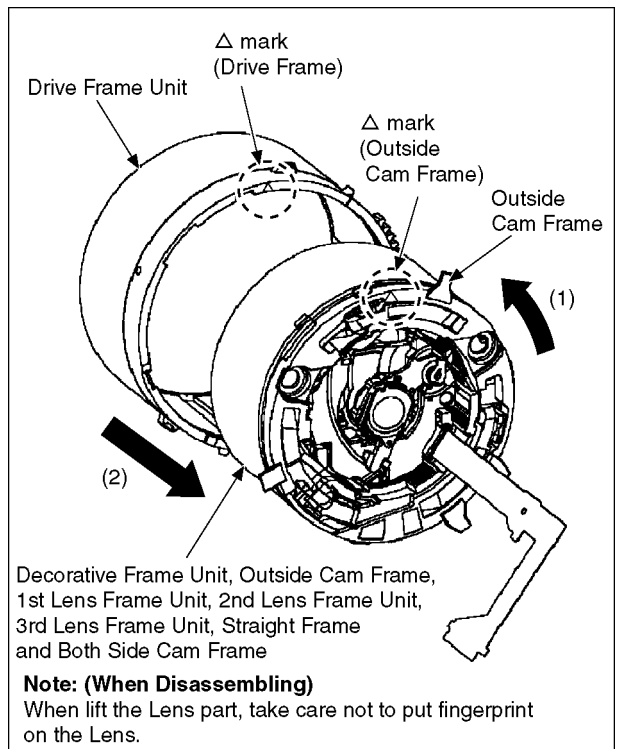

9.4.4. Removal of the Outside Cam Frame, 1st Lens Frame Unit, 2nd Lens Frame Unit, 3rd Lens Frame Unit, Straight Frame and Both Side Cam Frame

- Turn the Decorative Frame Unit in the arrow (1) direction, and remove the Unit of Outside Cam Frame, 1st Lens Frame Unit, 2nd Lens Frame Unit, 3rd Lens Frame Unit, Straight Frame and Both Side Cam Frame from the Decorative Frame Unit in the arrow (2) direction.

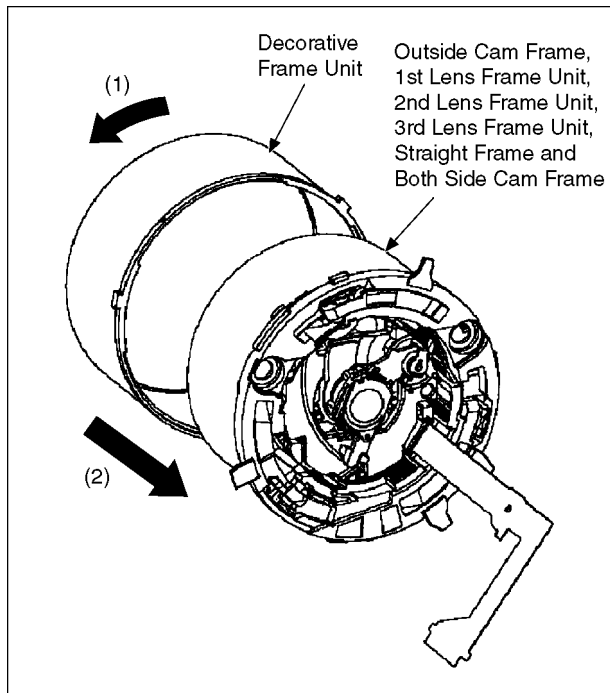

9.4.5. Removal of the 1st Lens Frame Unit, 2nd Lens Frame Unit, 3rd Lens Frame Unit, Straight Frame and Both Side Cam Frame

- Hold the Both Side Cam Frame and turn it in the arrow direction. Align the Δ mark (Outside Cam Frame and Both Side Cam Frame), and then remove the Unit of 1st Lens Frame Unit, 2nd Lens Frame Unit, 3rd Lens Frame Unit, Straight Frame and Both Side Cam Frame from the Outside Cam Frame.

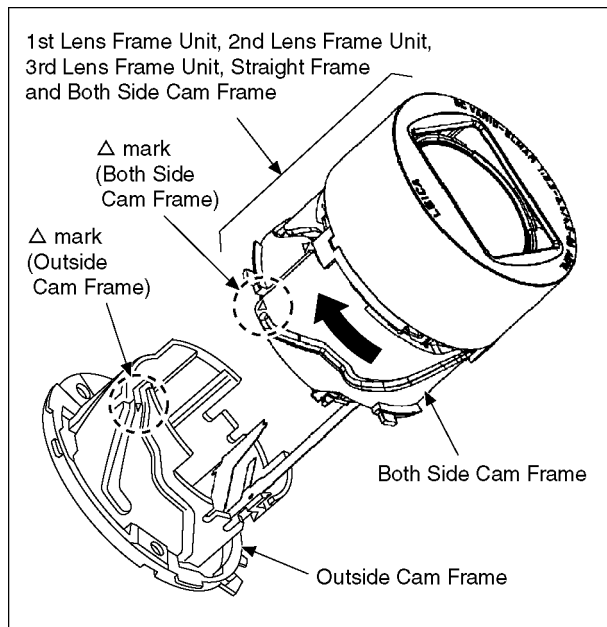

9.4.6. Removal of the 1st Lens Frame Unit

- Turn the 1st Lens Frame Unit in the arrow (1) direction a little, and remove the Unit of 2nd Lens Frame Unit, 3rd Lens Frame Unit, Straight Frame and Both Side Cam Frame in the arrow (2) direction.

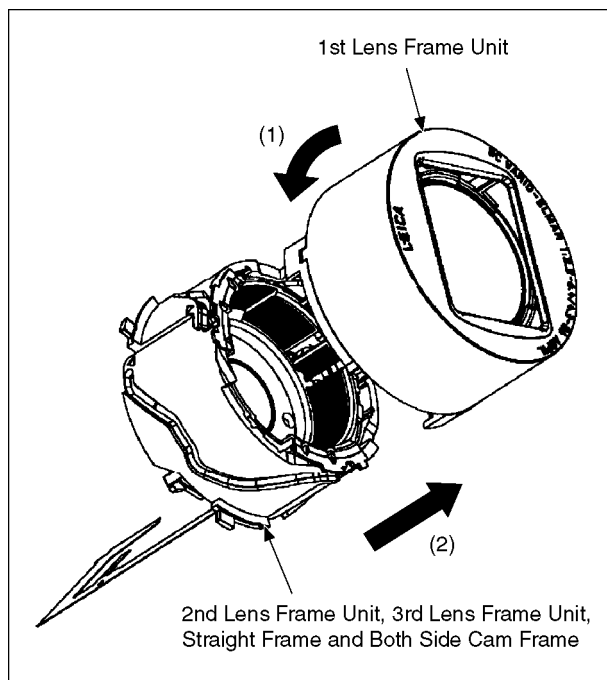

9.4.7. Removal of the 2nd Lens Frame Unit

1. Hold the Straight Frame and turn it in the arrow (1) so that the Δ mark (2nd Lens Frame Unit) meets the Δ mark (Straight Frame).
2. Pushing the 3rd Lens Frame Unit in the arrow (2) direction from the front of the Lens, turn it in the arrow (3) direction.

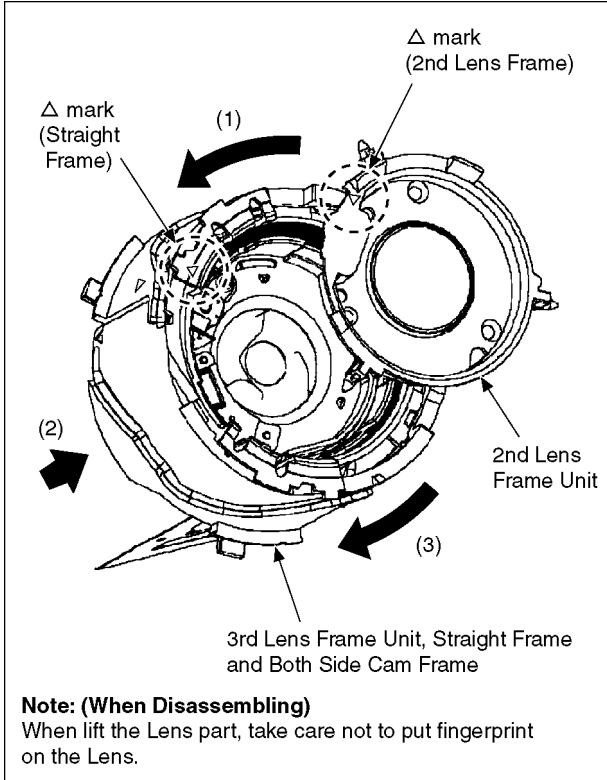

9.4.8. Removal of the 3rd Lens Frame Unit

- Push the 3rd Lens Frame Unit in the arrow direction from the front of the Lens, and remove the 3rd Lens Frame Unit from the Straight Frame and Both Side Cam Frame.

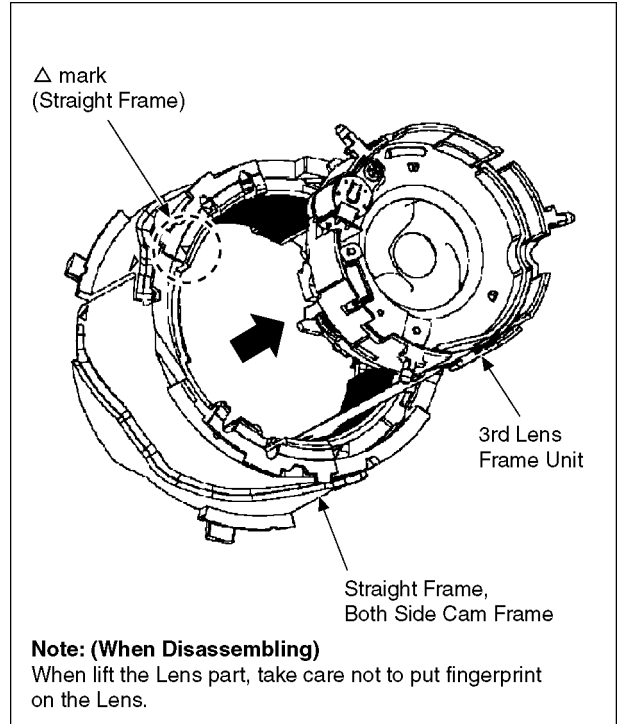

9.4.9. Removal of the Straight Frame

- Turn the Straight Frame in the arrow direction, and align the Δ mark (Straight Frame and Both Side Cam Frame) in the direction as below. Align the Bayonet Key with the Bayonet Inlet, and remove the Straight Frame from the Both Side Cam Frame.

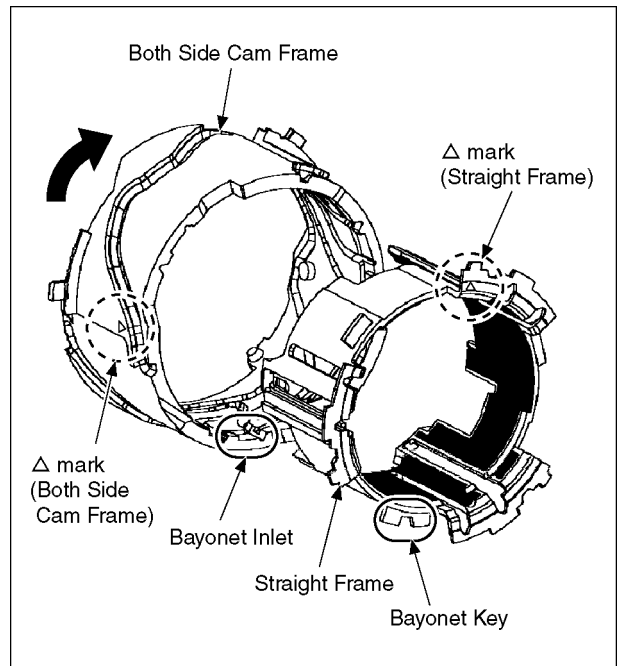

9.5. Assembly Procedure for Lens (Revised Version)

9.5.1. Insert the Straight Frame

Insert the Straight Frame into the Both Side Cam Frame as below.

(The phase difference between the two Δ marks is about 90 degrees.)

*The Δ mark of the Straight Frame is under the Shading Sheet.

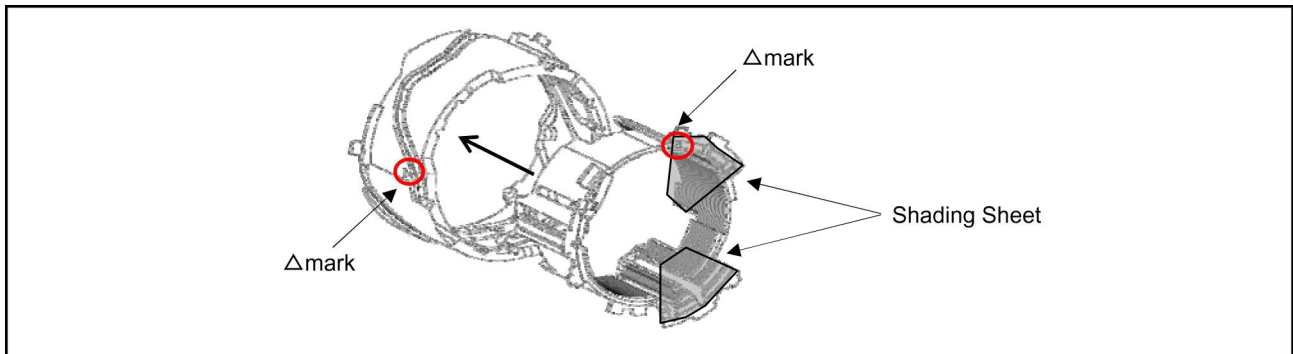

Insert the Bayonet Key of the Straight Frame into the Bayonet Inlet of the Both Side Cam Frame.

(Pass the convexity of Bayonet Inlet through the concavity of Bayonet Key.)

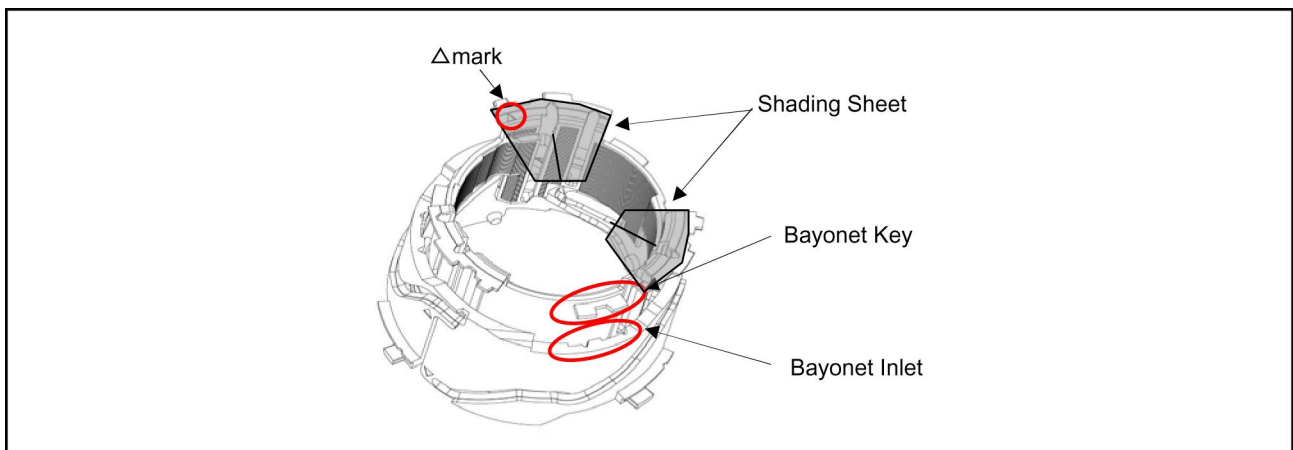

Turn the Straight Frame about 90 degrees in the arrow direction so that the Δ mark of Straight Frame comes close to the Δ mark of Both Side Cam Frame.

*As the drawing below indicates, align the Grooves of Straight Frame with the one of Both Side Cam Frame.

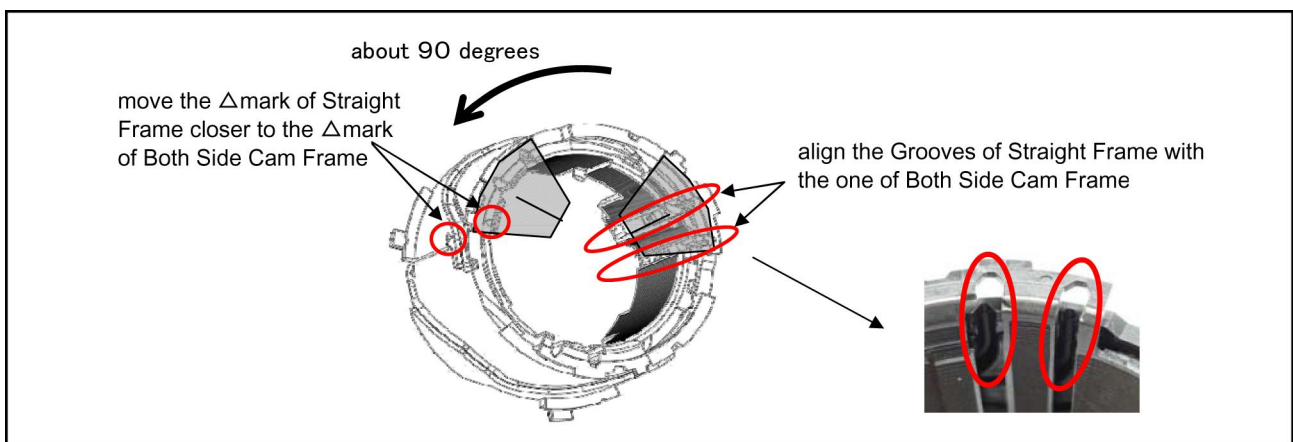

9.5.2. Insert the 3rd Lens Frame Unit and the 2nd Lens Frame Unit

Insert the 3rd Lens Frame Unit as the drawing below indicated.

*Align the Stepping Motor of the 3rd Lens Frame Unit with the Δ mark of the Straight Frame Unit, then put the each Cam Pin of the 3rd Lens Frame Unit in the each Groove of the Straight Frame Unit.

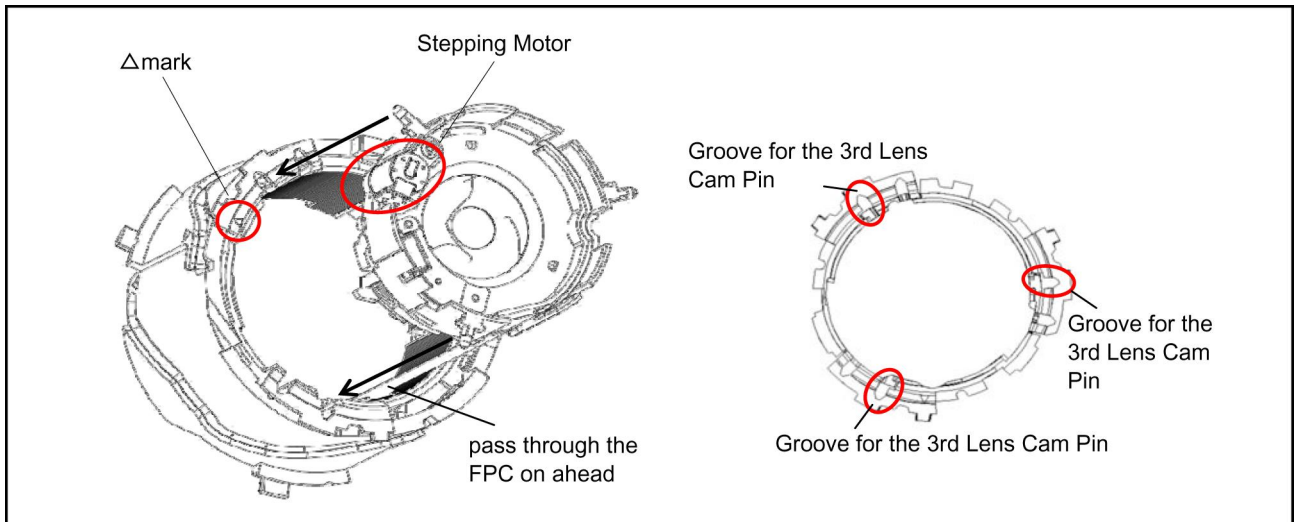

Insert the 2nd Lens Frame Unit as the drawing below indicated.

*Align the Δ mark of the 2nd Lens Frame Unit with the one of the Straight Frame Unit, then put the each Cam Pin of the 2nd Lens Frame Unit in the each Groove of the Straight Frame Unit.

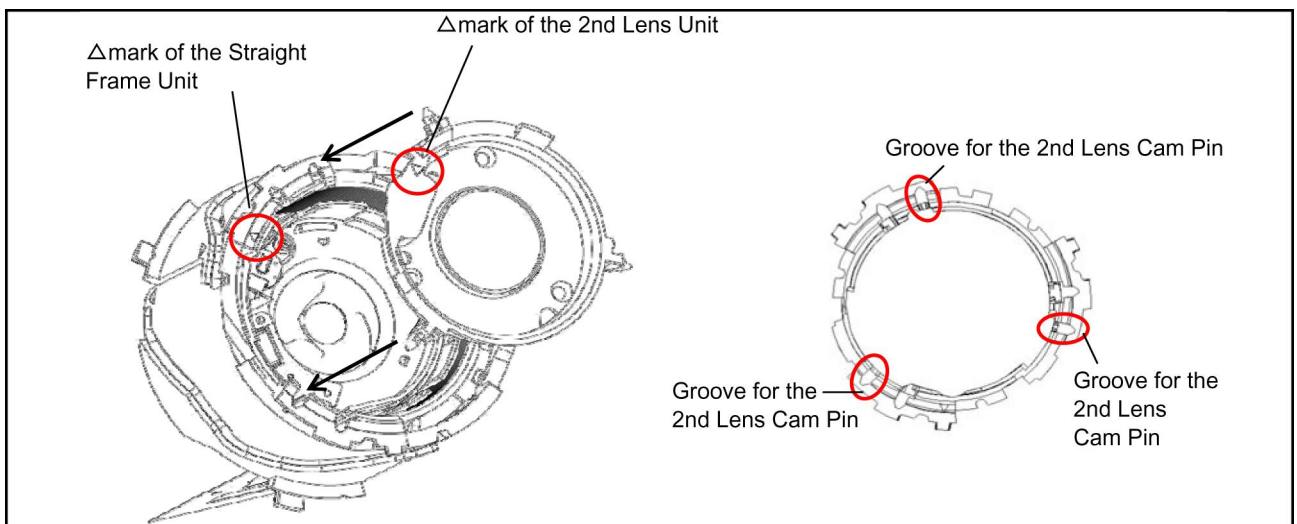

While pushing the 3rd Lens Frame Unit and the 2nd Lens Frame Unit, turn the Straight Frame Unit in the arrow direction to the end.(about 30 degree)

*Need to confirm that the two Lens Frames move smoothly when the Straight Frame Unit rotates in two directions.

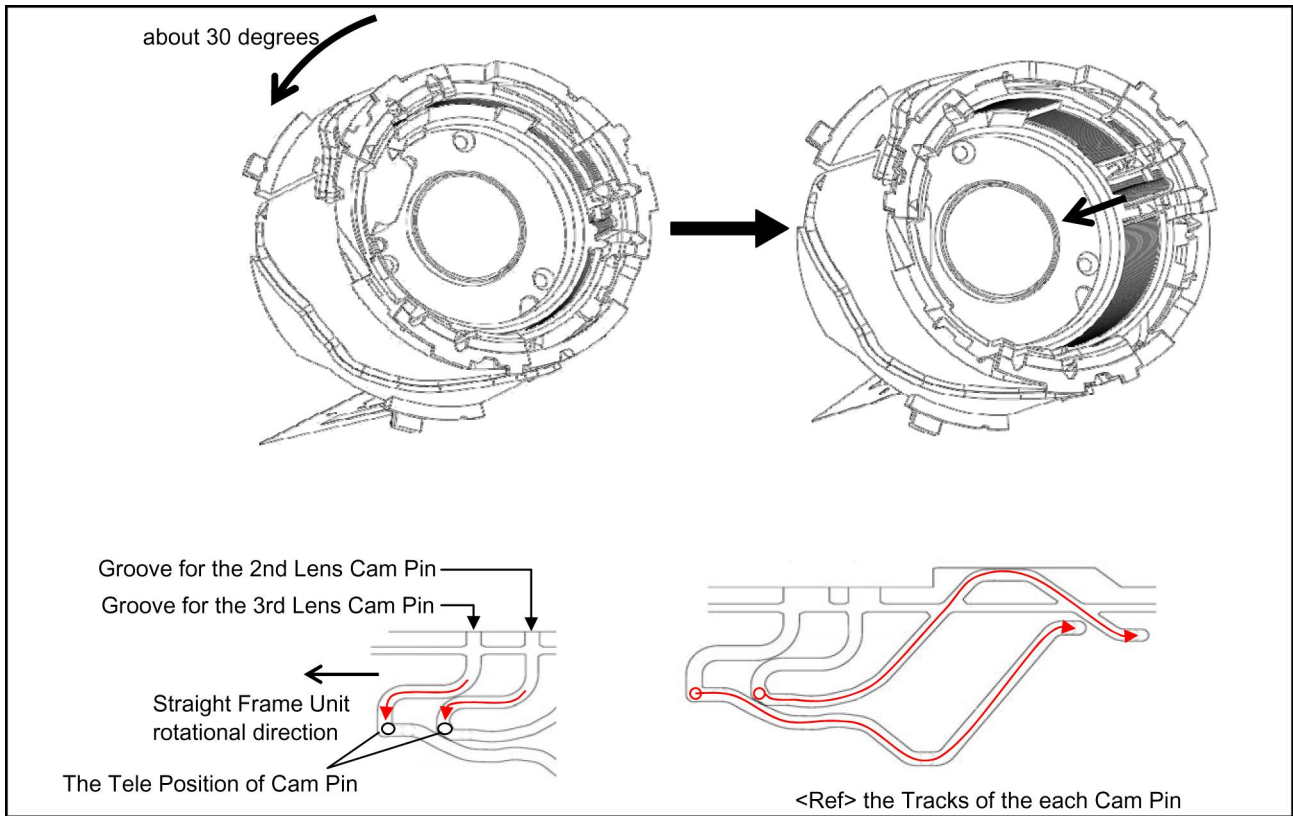

9.5.3. Insert the 1st Lens Frame Unit and the Outside Cam Frame Unit

Insert the 1st Lens Frame as the drawing below indicated.

Pass the Cam Pin of the "LEICA" side of the 1st Lens Frame Unit through the Area of Cam Pin Insertion near the Δ mark of Both Side Cam Frame Unit

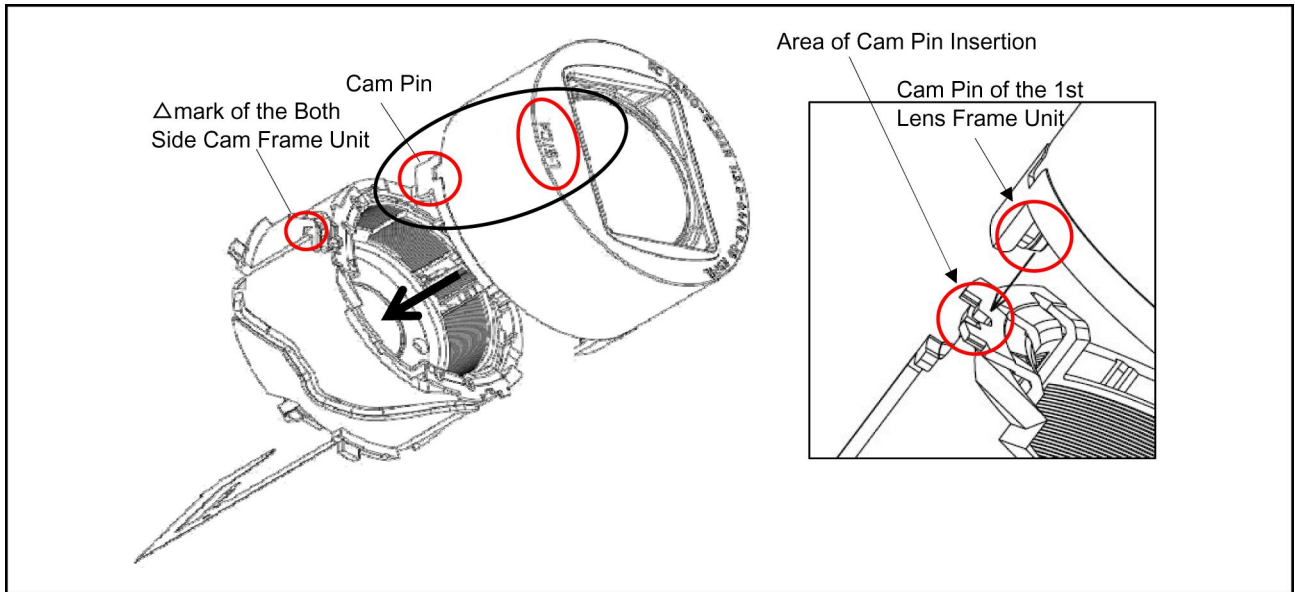

1. Move the Δ mark of the Both Side Cam Frame Unit closer to the Δ mark of the Outside Cam Frame Unit, then turn the 1st Lens Frame Unit just a bit in the arrow direction.(about 2 degrees)
 *Hold the Cam Pin of the Both Side Frame Unit close to the Straight Key of the Straight Frame Unit.
2. Insert the Straight Key and the Cam Pin into the following grooves.
 - (1)The Straight Key of the Straight Unit -> The groove for the Straight key of the Outside Cam Frame Unit
 - (2)The Cam Pin of the Both Side Cam Frame Unit -> The groove for the Cam Pin of the Outside Cam Frame Unit

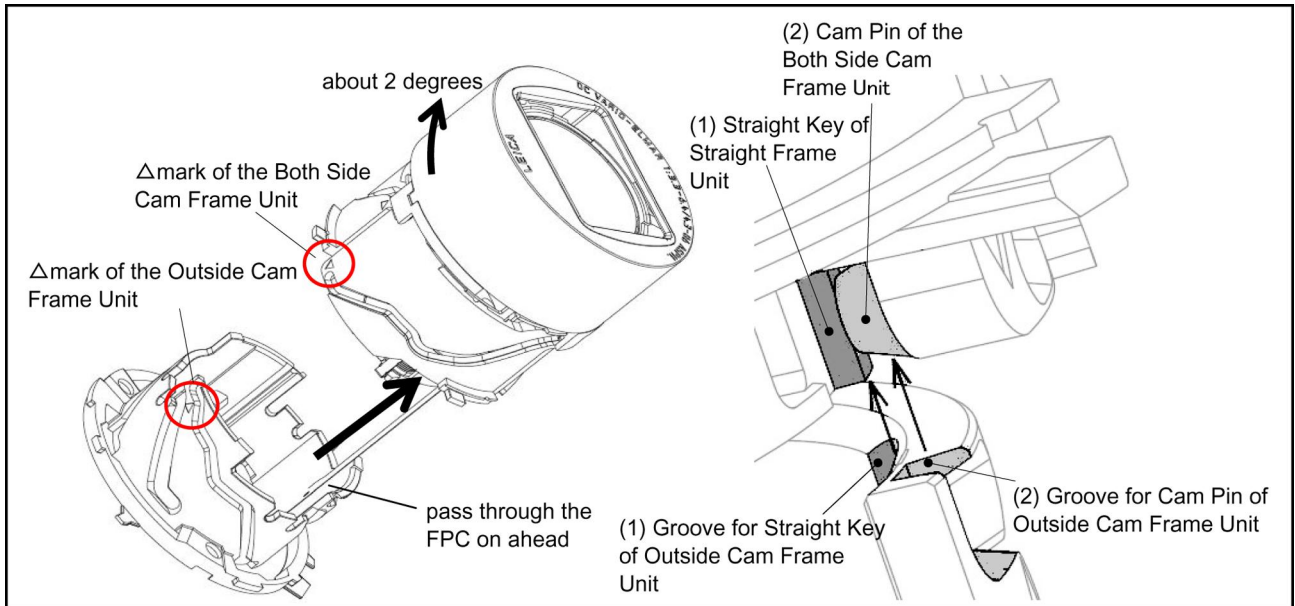

Turn the Both Side Cam Frame Unit to the end in the arrow direction while holding the Outside Cam Frame Unit.
(About 118.5 degrees)

*Confirm that 1st Lens Frame Unit does not rotate when the Both Side Cam Frame Unit rotates.
(It's the confirmation that previous insertion is done normally.)

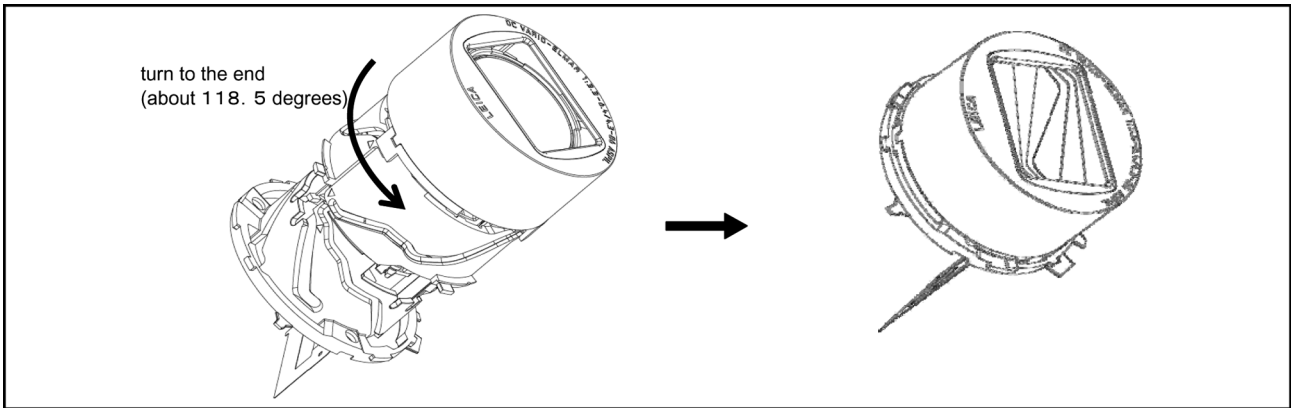

9.5.4. Insert the Decorative Frame Unit

1. Hold the Straight Key (Both Side Cam Frame), turn it in the arrow direction and align with the Straight Key (Outside Cam Frame).

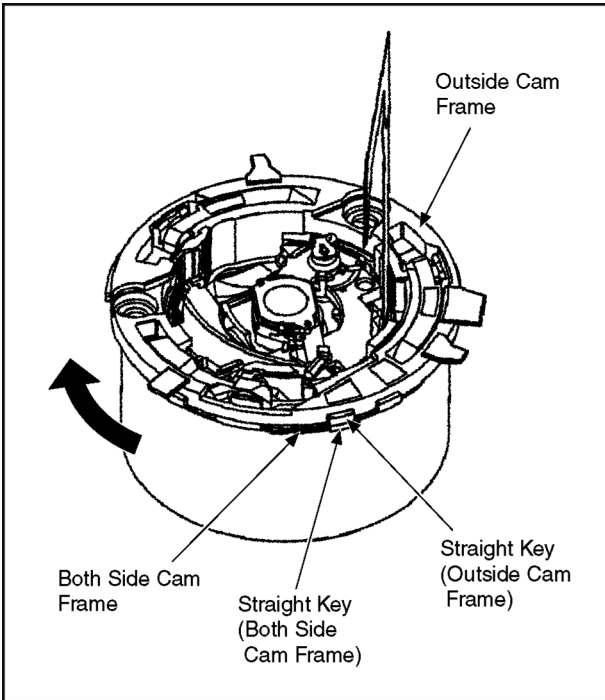

2. Insert 2 toothpicks (rotation stopper) in the position as below.

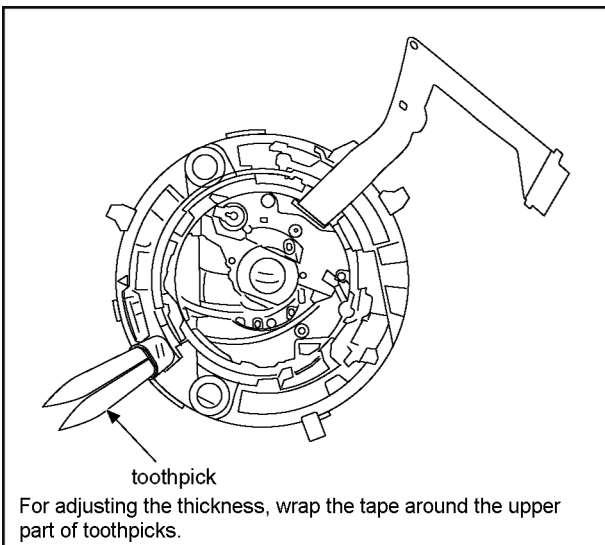

3. Align the Δ mark (Decorative Frame) with the Straight Key (Both Side Cam Frame), and install the Unit of Outside Cam Frame, 1st Lens Frame Unit, 2nd Lens Frame Unit, 3rd Lens Frame Unit, Straight Frame and Both Side Cam Frame to the Decorative Frame Unit.

4. Turn the Decorative Frame Unit in the arrow (2) direction so that the Δ mark (Decorative Frame) meets the Δ mark (Outside Cam Frame).

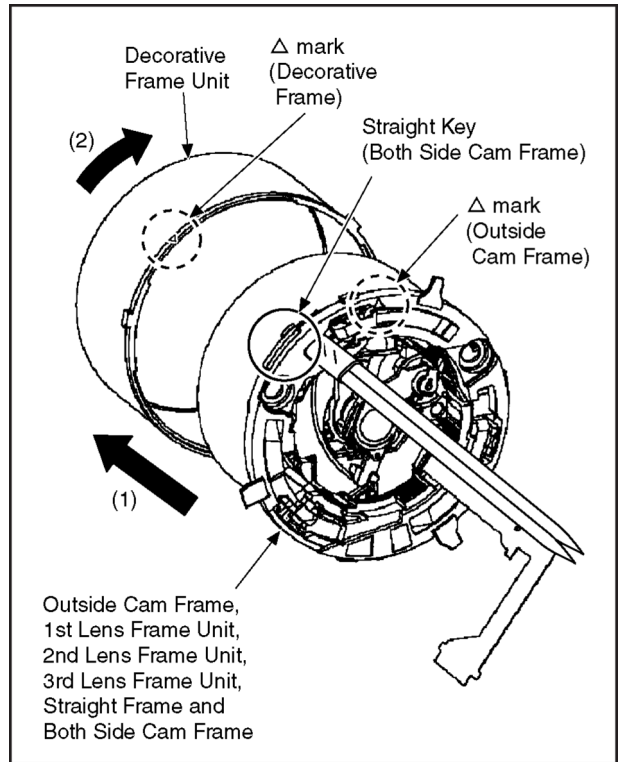

9.5.5. Insert the Drive Frame Unit

- Align the Δ mark (Drive Frame and Outside Cam Frame), and install the Unit of Decorative Frame Unit, Outside Cam Frame, 1st Lens Frame Unit, 2nd Lens Frame Unit, 3rd Lens Frame Unit, Straight Frame and Both Side Cam Frame to the Drive Frame Unit.

*Keep the toothpicks (rotation stopper) inserted.

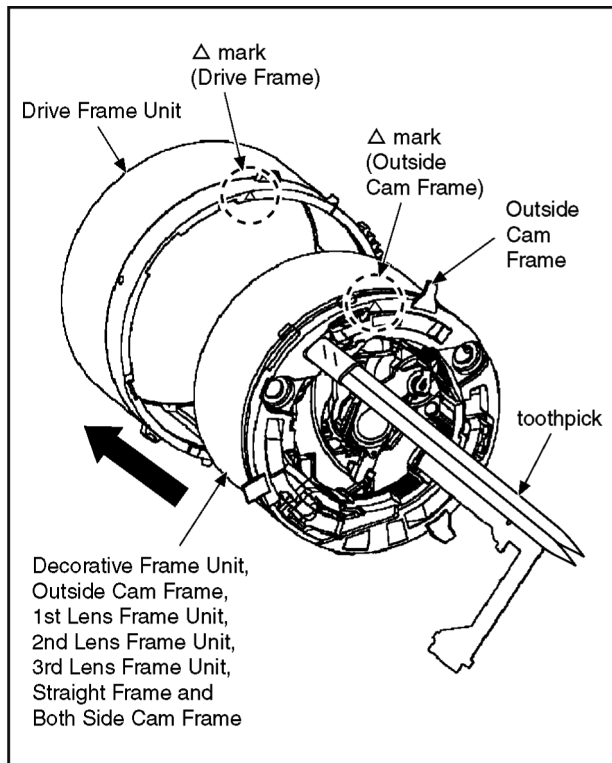

9.5.6. Insert the Fix Frame Unit

1. Install the Drive Gear to the Fix Cam Frame Unit.
2. Align the Δ mark (Outside Cam Frame and Drive Frame) and install the Unit of Drive Frame Unit, Decorative Frame Unit, Outside Cam Frame, 1st Lens Frame Unit, 2nd Lens Frame Unit, 3rd Lens Frame Unit, Straight Frame and Both Side Cam Frame to the Fix Cam Frame Unit.

*Keep the toothpicks (rotation stopper) inserted.

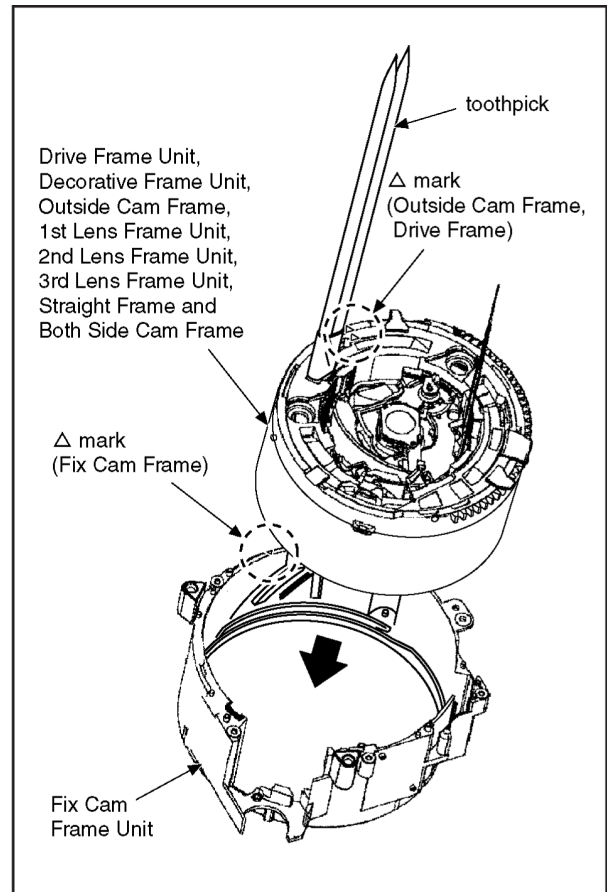

3. Remove the toothpicks (rotation stopper) and insert the Drive Gear.

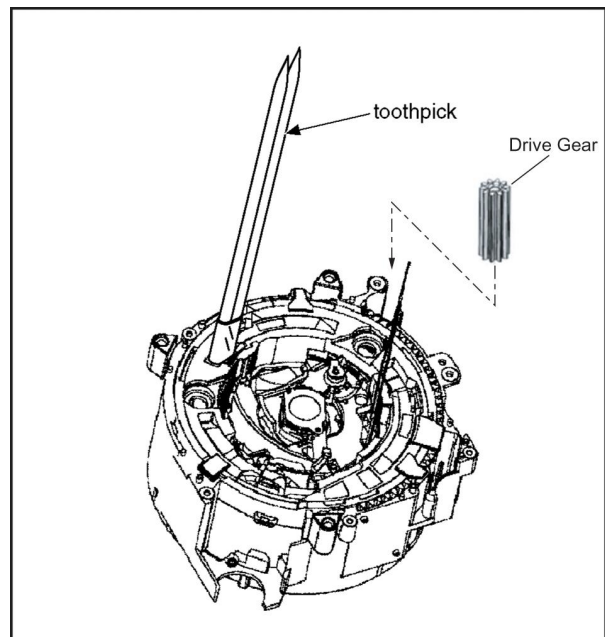

9.5.7. Insert the Master Flange Unit

Note: (When Installing)

Refer to "The Application of Grease Method" when installing the Master Flange Unit.

Take Care not to damage the flex.

Take Care not to tuck in to the Master Flange Unit, When inserting the Shutter Flex.

1. Turn the Drive Frame Unit to the Wide position as below.
2. Push the Hole of the Shutter Flex to the Boss of the Master Flange Unit tightly.
3. Place the Shutter Flex following the Guide of the Fix Cam Frame, and install the Master Flange Unit to the Unit of Fix Cam Frame Unite, Drive Frame Unit, Decorative Frame Unit, Outside Cam Frame, 1st Lens Frame Unit, 2nd Lens Frame Unite, 3rd Lens Frame Unit, Straight Frame and Both Side Cam Frame.
4. Turn the Drive Frame Unit to the completely retracted position.

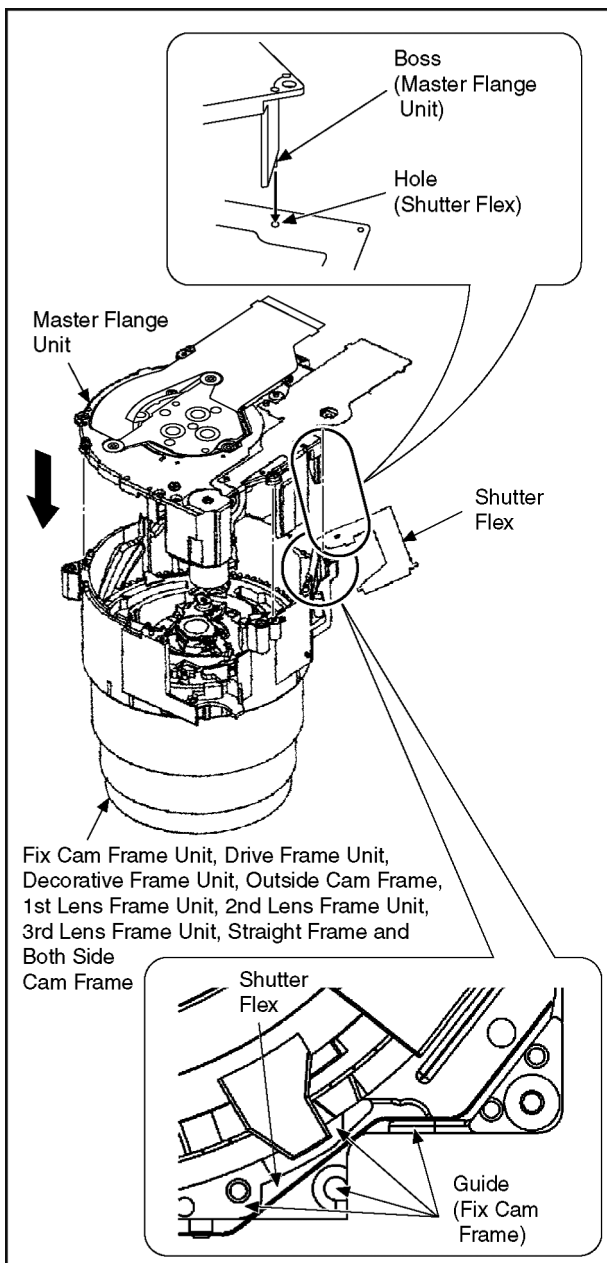

5. Join the Zoom Motor Unit to the Boss, and install to the Fix Cam Frame.

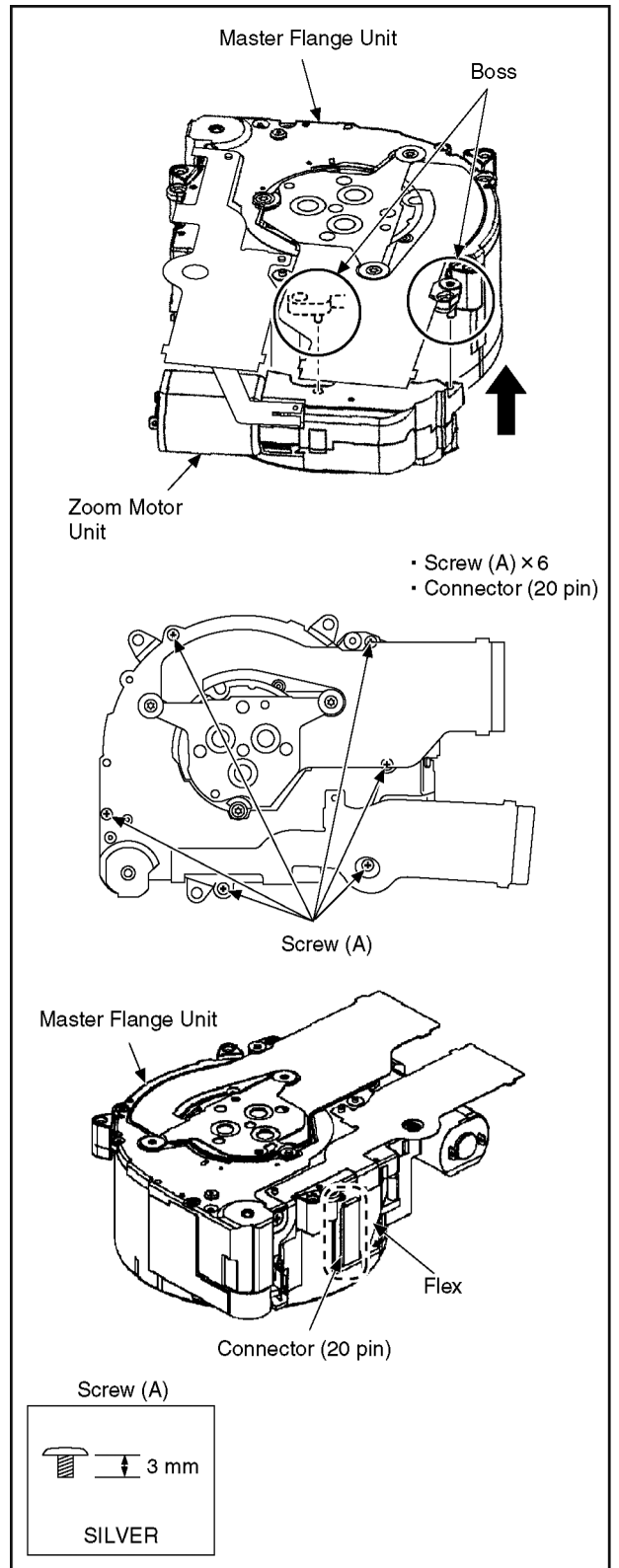

9.6. Removal of the CMOS Unit

When remove the CMOS Unit once (the Torx screw (A) is loosened even a little), the optical tilt adjustment is required.

When loosen the Torx screw (A), necessary the optical tilt adjustment at the end of assembling. (Refer to item "10.3.2.")

To prevent the CMOS Unit from catching the dust and dirt, do not remove the CMOS Unit except for replacing.

CAUTION

- The Torx screw (A) is fixed by the screw locking glue with the optical tilt adjustment finished. When remove the CMOS Unit, wipe the screw locking glue away carefully.
- Don't reuse the Torx screw (A) that the screw locking glue adheres to keep dust or dirt away from the CMOS Unit. (When installing, use new Torx screw (A).)

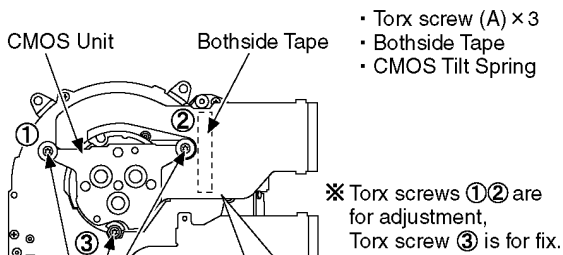

Torx screw (A)

Torx screw (A)

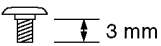

Torx type (T6)
SILVER

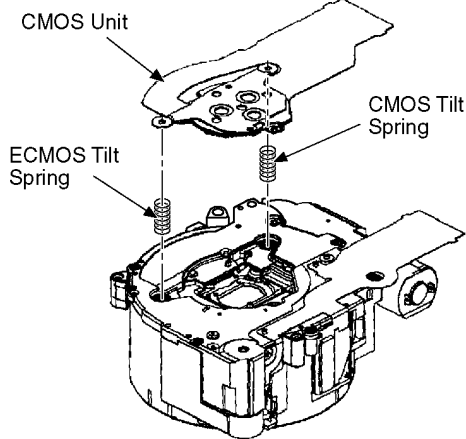
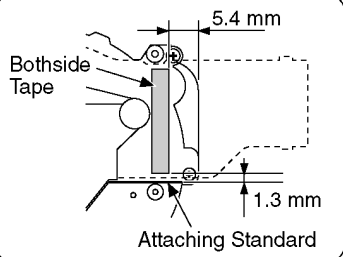

NOTE: (When Replacing)

- When attaching the Bothside Tape, confirm the attaching position to attach.
- When removing/attaching screw (A), use Torx screwdriver (Part No.: VFK1981).
- Take new Torx screw. (Do not reuse the Torx screw that the screw locking glue adheres.)
- Be sure to execute the optical tilt adjustment with the Torx screw ① and ②.
- Tighten the 3 Torx screws in order ①→②→③.
- Screw torque: $5 \pm 0.5 \text{ N} \cdot \text{cm}$
- After the adjustment is finished, apply the screw locking glue as shown on the next item in the figure.

- Remove the bond curing UV completely, then apply the screw locking glue for services to opposite the place of the original application. (Do not adhere locking glue to the head of Torx screw (tilt screw))

(Example)

This is the case where the screw locking glue is applied to inside of the broken line.

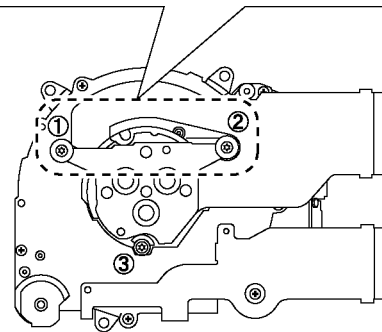
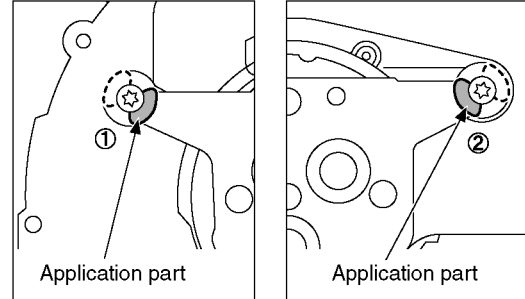

10 Measurements and Adjustments

10.1. Introduction

When servicing this unit, make sure to perform the adjustments necessary based on the part(s) replaced. Before disassembling the unit, it is recommended to back up the camera data stored in flash-rom as a data file.

IMPORTANT NOTICE (After replacing the Main P.C.B.)

After replacing the Main P.C.B., it is necessary to use the "DIAS" software to allow the release of adjustment flag(s).

The Adjustment software "DIAS" is available at "TSN Website". To download, click on "Support Information from NWBG/VDBG-AVC".

*DIAS (DSC Integrated Assist Software)

10.2. Before Disassembling the unit

10.2.1. Initial Setting Release

The cameras specification are initially set in accordance with model suffix (such as EB, EG, GK, GC, and so on.).

Unless the initial setting is not released, an automatic alignment software in the camera is not able to be executed when the alignment is carried out.

Note:

The initial setting should be again done after completing the alignment. Otherwise, the camera may not work properly.

Therefore as a warning, the camera display a warning symbol " ! " on the LCD monitor every time the camera is turned off.

Refer to the procedure described in "3.4.2. INITIAL SETTINGS" for details.

[How to Release the camera initial setting]

Preparation:

Attach the Battery to the unit.

Set the recording mode dial to PROGRAM AE mode.

Step 1. Temporary cancellation of "INITIAL SETTINGS":

Set the REC/PLAYBACK selector switch to "REC" (Camera mark).

While pressing the UP of Cursor button and MOTION PICTURE button simultaneously, turn the Power SW on.

Step 2. Cancellation of "INITIAL SETTINGS":

Set the REC/PLAYBACK selector switch to "PLAYBACK".

While pressing UP of Cursor button and MOTION PICTURE button simultaneously. (The camera will beep after this.)

Turn the Power off. (The warning symbol " ! " is displayed on the LCD monitor.)

10.2.2. Flash-Rom Data Backup

When trouble occurs, it is recommended to backup the Flash-rom data before disassembling the unit. There are two kinds of Flash-rom data backup methods:

[ROM_BACKUP (Method of Non-PC backup)]

1. Insert the SD-card into the camera.
2. Set the camera to "Temporary cancellation of the initial settings".
3. Select the "SETUP" menu.
From the "SETUP" menu, select "ROM BACKUP".

Note:

This item is not listed on the customer's "SET UP" menu.

4. When this "ROM_BACKUP" item is selected, the following submenus are displayed.

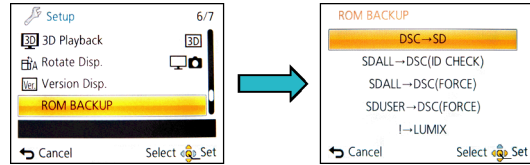

Item	Function	Details
DSC → SD	Save all the DSC's Flash-rom data to SD-CARD	<ul style="list-style-type: none"> • DSC's Flash-rom data is saved to the SD-CARD as a data file by the same format as the TATSUJIN software for the previous models. (DATA BACKUP) -File location: ROOT DIRECTORY in SD-CARD. -File Name: <ol style="list-style-type: none"> 1) User Setup Information data : <Model Number>U.txt [In case of TZ30 : 2 files named "TZ30U.TXT" and "TZ30U3.TXT"] 2) Optical Adjustment data : <Model Number>F.txt [In case of TZ30 : 2 files named "TZ30F.TXT" and "TZ30F3.TXT"] • If the concerned file already exists, "OVERWRITE?" message is displayed.
SDALL → DSC (ID CHECK)	Write the all data to DSC's Flash-rom from SD-CARD	<ul style="list-style-type: none"> • The backup data being stored in the SD card is transferred to DSC unit. • ID CHECK: When the model ID is different, data is not transferred.
SDALL → DSC (FORCE)	Write the all data to DSC's Flash-rom from SD-CARD	<ul style="list-style-type: none"> • FORCE: Even if the model ID is different, data is transferred. * If the main PCB is replaced, select "SDALL→DSC(FORCE)".
SDUSER → DSC (FORCE)	Only "User setup information" is written from the saved file in the SD-CARD to DSC's Flash-rom.	<ul style="list-style-type: none"> • Only the user's "setup" setting condition is transferred to DSC unit. • FORCE: Even if the model ID is different, the data is transferred.
! → LUMIX	Shipping set without initializing "User setup information"	<ul style="list-style-type: none"> • Initial setting is executed without initializing the user's set up setting condition. * The initial setting must be perform while the Self-timer LED is blinking, * The picture data stored in the built-in memory of the DSC is not erased, with this operation.

[DSC Integrated Assist Software (Method of Using PC)]

Same as TATSUJIN software for previous models.

10.2.3. Light Box

If using VFK1164TDVLB Light Box, remove the lens connection ring by loosening three hexagon screws.

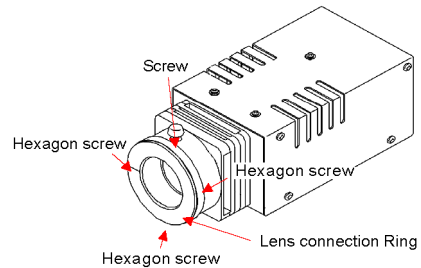

10.3. Details of Electrical Adjustment

10.3.1. How to execute the Electrical Adjustment

It is not necessary to connect the camera to a PC to perform adjustments.

"Flag reset operation" and "Initial setting operation" are required when carrying out the alignment, follow the procedure below.

10.3.1.1. Startup Electrical Adjustment mode

1. Release the initial settings.
2. Insert a recordable SD card.
(Without a SD card, the automatic adjustment can not executed.)
3. Procedure to set the camera into adjustment mode:
 - a. Set the mode into PROGRAM AE mode.
 - b. Set the REC/PLAYBACK selector switch to "REC" (Camera mark).
 - c. Turn the Power SW off.
 - d. Turn the Power SW on pressing MOTION PICTURE and MENU/SET simultaneously.
LCD monitor displays "SERVICE MODE".
(Refer to Fig.F3-1)

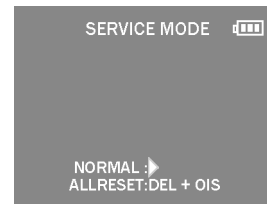

Fig. 3-1

10.3.1.2. Status Adjustment Flag Setting

Reset (Not yet adjusted) the status flag condition.

1. After pressing the DISPLAY button, the LCD monitor displays the Flag status screen (Refer to Fig.3-2.)
2. Select item by pressing the cross keys. (Gray cursor is moved accordingly.)
3. Press the DELETE button.

Note:

The selected item's flag has been changed from "F (green)" to "0 (yellow)".

*(Refer to Fig. 3-3)

*Flag conditions:

F (green)

means that the alignment has been completed and the status flag condition is set. In this case, the flag condition should be reset, if you try to carry out the automatic alignment.

0 (yellow)

means that the alignment has been not "completed" and the status flag condition is "reset". In this case, automatic alignment is available.

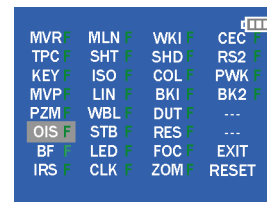

Fig. 3-2

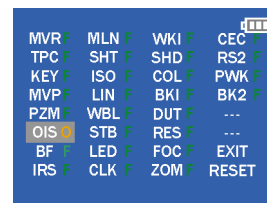

Fig. 3-3

- In case of setting the status flag into set condition again without completion of the alignment, the status flag should be SET by using PC, or UNDO by using ROM BACKUP function.

10.3.1.3. Execute Adjustment

1. Perform step "10.3.1.1." to "10.3.1.2.", to reset the OIS flag status "F" (Set) to "0" (Reset).
2. Press **DISPLAY** button after Flag reset.
OIS Adjustment screen is displayed on the LCD panel.
(Refer to Fig.3-4)
3. Press the shutter button. The adjustment will start automatically.
4. When the adjustment is completed successfully, adjustment report menu appears with Green OK on the LCD monitor. (Refer to Fig.3-5)

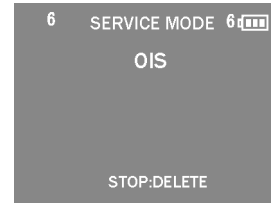

Fig. 3-4

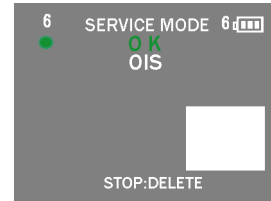

Fig. 3-5

10.3.1.4. Attention point during Adjustment

1. Step "10.3.1.3." procedure shows OIS adjustment as an example. To perform the adjustment, refer to the "10.3.2. Adjustment Specifications" table which shows key point for each adjustment.
2. Do not move the light box, the camera or the chart while adjusting. If one of these is moved accidentally, start the adjustment again.
3. Do not press any buttons/keys until the default menu (Fig.3-6) is displayed on the LCD monitor. Otherwise, adjustment data may not be stored properly.
4. If the adjustment is interrupted accidentally, the alignment data may not be properly saved in the Flash-rom.

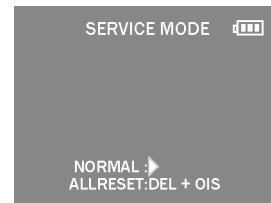

Fig. 3-6

10.3.1.5. Finalizing the Adjustment

1. Several adjustment flags can be reset ("F" into "0") at the same time. In this case, when the adjustment has been completed, the screen will change showing the adjustment for the next item until all reset items are completed.
Also, when the shutter button is pressed, the screen jump to the next adjustment item.
2. To cancel the adjustment mode while in the process of performing the adjustment, follow this procedures.
(1) Press "Right of cross key" button.

Note:

- *.If adjustment is cancelled with above procedure, adjustment is not completed. Make sure to adjust it later.
- *.Adjustment software "DIAS" is able to control the status of the adjustment flags.

10.3.2. Adjustment Specifications

The following matrix table shows the relation between the replaced part and the Necessary Adjustment.

When a part is replaced, make sure to perform the necessary adjustment(s) in the order indicated.

The table below shows all the information necessary to perform each adjustment.

Adjustment order	Adjustment Item	FLAG	Purpose	Replacing Parts						JIG/TOOLS	SET UP	How to Operate
				MAIN PCB/ VENUS ENGINE (IC6001)/ MCP (IC6002)	Lens Parts/CMOS UNIT	MIC UNIT	GYRO (IC7101)	FLASH UNIT	TOUCH PANEL Part			
1	Optical Tilt	-	Align the image sensor installation angle to the Lens	-	○	-	-	-	-	-	Note: · When the Lens Part (include CMOS Unit) or CMOS Unit is replaced, make sure to perform the "Optical tilt adjustment" before another "Optical Adjustment". · The "DSC Tilt" software (include the "Optical tilt adjustment process document") for the "Optical tilt adjustment" is specially uploaded on the Web-site.	
2	Touch Panel Control	TPC	Touch Panel Inspection	-	-	-	-	-	○	Touch Pen	NONE	1)Touch "+" mark displayed on the LCD with the touch pen 5 times in order as below. (upper left → lower left → lower right → upper right → center) 2)After completed, the "OK" menu appears.
3	Venus Zoom	PZM	Venus Zoom Inspection	○	-	-	-	-	-	NONE	NONE	1)Press Shutter Button. 2)After completed, the "OK" menu appears.
4	OIS sensor	OIS	OIS sensor output level adjustment	○	○	-	-	-	-	NONE	NONE	1)Press Shutter Button (Do not apply any shock and vibration for the camera while adjusting) 2)After completed, the "OK" menu appears.
5	Back focus / GYRO	BF	To have the focus tracking curve be appropriate shape and GYRO sensor adjustment	○	○※1	-	○	-	-	-COLLIMATOR (RFKZ0422)	1)Set the camera in front of collimator so that the distance from collimator to camera becomes about 5.5 cm as shown in Fig. A. 2)Set the camera angle so that the center of the chart comes to the center of the LCD monitor. [IMPORTANT] The adjustment "NG" might be happened with the following conditions: - Do not put the black colored stuff at the back side of collimator near hunching chart. It needs to get some certain brightness. - Make sure the hunching chart has no dust and dirty condition. - Do not connect a USB cable during adjustment.	1)Press Shutter Button (Do not apply any shock and vibration for the camera while adjusting) 2)After completed, the "OK" menu appears.
6	Iris	IRS	Iris adjustment	○	○	-	-	-	-	-LIGHT BOX (VFK1164TDVLB or RFKZ0523)	1)Set the camera in front of LIGHT BOX so that the distance from LIGHT BOX to camera becomes about 8 cm as shown in Fig. B. 2)Aim the LIGHTBOX so that the entire LCD screen becomes fully "white". (No dark area).	1)Press Shutter Button 2)After completed, the "OK" menu appears.
7	Monitor Linearity	MLN	Monitor Linearity adjustment	○	○	-	-	-	-		1)Press Shutter Button 2)After completed, the "OK" menu appears.	
8	Shutter	SHT	Shutter speed adjustment	○	○	-	-	-	-		1)Set the camera in front of LIGHT BOX so that the distance from LIGHT BOX to camera becomes about 12 cm as shown in Fig. B. 2)Aim the LIGHTBOX so that the entire LCD screen becomes fully "white". (No dark area).	1)Press Shutter Button 2)After completed, the "OK" menu appears.
9	ISO	ISO	ISO sensitivity adjustment	○	○	-	-	-	-	-LIGHT BOX (VFK1164TDVLB or RFKZ0523) -TR CHART (RFKZ0443)	1) Insert the TR chart into the slot of LIGHT BOX. 2) Set the camera in front of LIGHT BOX so that the distance from LIGHT BOX to camera becomes about 15 cm as shown in Fig. B. 3) Set the camera angle so that the color chart is displayed on the LCD monitor fully.	1)Press Shutter Button 2)After completed, the "OK" menu appears.
10	High brightness coloration	LIN	High brightness coloration adjustment	○	○	-	-	-	-		[IMPORTANT] The adjustment "NG" might be happened with the following conditions: - Since the lens position is automatically set into certain position after executing auto adjustment, confirm the angle after stopping the lens zoom position. - It is no problem even though the chart on to the LCD monitor slightly cut at the corner. - It is no problem even though the focusing slightly becomes out of focusing condition. - Not connect the USB cable at this stage.	1)Press Shutter Button 2)After completed, the "OK" menu appears.
11	White Balance	WBL	White balance adjustment under various color temperature	○	○	-	-	-	-		1)Press Shutter Button 2)After completed, the "OK" menu appears.	
12	Flash	STB	Flash Inspection	○	-	-	-	○	-	NONE	NONE	1)Press Shutter Button and check that Flash is emitted. (The number of emissions differs depending on the model.) If Flash is not emitted, Flash Unit may be damaged. 2)If the inspection result shows "NG", use "DIAS" and rewrite STB to confirm it is adjusted. The result may show "NG" if the inspection is performed on sites other than the specific environment (factory). However, if the flash emission is visible, there is no problem. 3)After completed, the "OK" menu appears.
13	CMOS Missing Pixels (White)	WKI	Compensation of CMOS Missing Pixels (White)	○	○※1	-	-	-	-	NONE	NONE	1)Press Shutter Button 2)After completed, the "OK" menu appears.

Adjustment order	Adjustment Item	FLAG	Purpose	Replacing Parts							JIG/TOOLS	SET UP	How to Operate
				MAIN PCB/ VENUS ENGINE (IC6001)/ MCP (IC6002)	Lens Parts (include CMOS U)/ CMOS UNIT	MIC UNIT	GYRO (IC7101)	FLASH UNIT	TOUCH PANEL Part				
14	Color reproduction inspection and Microphone check	COL	Color reproduction inspection and Microphone check	○	○	○	—	—	—	NONE	Right after pressing the shutter button, enter the continuous sounds (voice) to the microphone until lens unit starting the zooming.	1) Press Shutter Button. Right after pressing the shutter button, make a continuous sound (voice) to the microphone until lens unit starting the zooming. 2) After completed, the "OK" menu appears.	
		BK1	Do not use "BK1" adjustment flag for this unit. Use "BK2" adjustment flag instead. (In case of most DSC models, the adjustment flag for CMOS Missing Pixels is "BK1". But, in this model, "BK2" the adjustment flag for CMOS Missing Pixels.)										
15	CMOS Missing Pixels (Black)	BK2	Compensation of CMOS Missing Pixels (Black)	○	○	—	—	—	—	—	<p>1) Prepare the LIGHTBOX (RFKZ0523). (The LIGHTBOX "VFK1164TDVLB" can be used if the front hood of VFK1164TDVLB is removed.)</p> <p>2) Set the diffuser (RFKZ0591) to the LIGHTBOX.</p> <p>3) Set the LIGHTBOX and Camera unit so that distance becomes about 4.0 cm. (Fig. B)</p> <p>NOTE: Do not use "BK1" adjustment flag for this unit. Use "BK2" adjustment flag instead.</p>	<p>1) Set the LIGHTBOX and Camera unit so that the distance becomes about 4.0 cm. (Refer to Fig. B)</p> <p>2) Press the Shutter Button. (The green mark is displayed on LCD.)</p> <p>3) Aim the LIGHTBOX and make the frame detail alignment so that the entire LCD screen becomes fully "white". (No dark area.)</p> <p>4) Press Shutter Button. (The adjustment is executed, and then green mark is displayed on LCD.)</p> <p>5) Set the LIGHTBOX and Camera unit so that the distance becomes about 5.0 cm. (Refer to Fig. B)</p> <p>6) Press Shutter Button. (The green mark is displayed on LCD.)</p> <p>7) Press Shutter Button. (The adjustment is executed, and then green mark is displayed on LCD.)</p> <p>8) Set the LIGHTBOX and Camera unit so that the distance becomes about 6.0 cm. (Refer to Fig. B)</p> <p>9) Press Shutter Button. (The green mark is displayed on LCD.)</p> <p>10) Press Shutter Button. (The adjustment is executed, then "OK" mark is displayed on LCD when the adjustment has been completed successfully.)</p>	

※1 This adjustment must be performed not only replacing the CMOS unit, but also simply removing the CMOS unit.

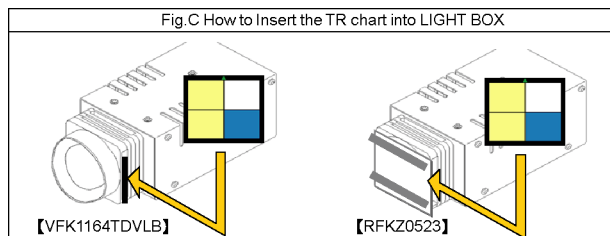
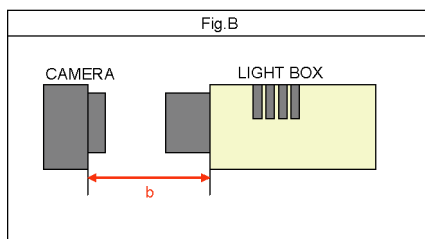
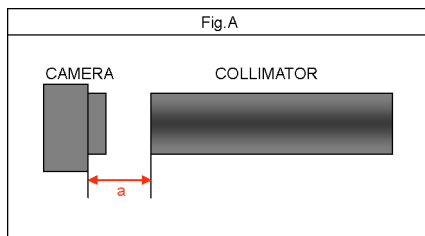

IMPORTANT NOTICE (After replacing the Main P.C.B.)
After replacing the Main P.C.B., make sure to perform the "INITIAL SETTINGS" first, then release the "INITIAL SETTINGS" in order to proceed the electrical adjustment.

Note:

1. If electrical adjustment or data re-writing is executed before "INITIAL SETTINGS", suffix code list is never displayed, and it cannot be chosen suitable suffix code.
2. Never remove the battery during initial setting in process.

10.4. After Adjustment

10.4.1. Initial Setting

Since the initial setting has been released to execute the built-in adjustment software, it should be set up again before shipping the camera to the customer.

Refer to the procedure described in "3.4.2. INITIAL SETTINGS" for details.

[IMPORTANT]

1. The initial setting should be done again after completing the alignment. Otherwise, the camera will not work properly.
Therefore as a warning, the camera display a warning symbol " ! " on the LCD monitor every time the camera is turned off.
2. Confirm that status of all adjustment flag show "F". Even if one of the adjustment flag shows "0", initial setting programmed is never executed.
3. Adjustment software "DIAS" is able to control the status of the adjustment flags.
The Adjustment software "DIAS" is available at "TSN Website", therefore, access to "TSN Website" at "Support Information from NWBG/VDBG-AVC".

11 Maintenance

11.1. Cleaning Lens, Viewfinder and LCD Panel

Do not touch the surface of lens, Viewfinder and LCD Panel with your hand.

When cleaning the lens, use air-Blower to blow off the dust.

When cleaning the LCD Panel, dampen the lens cleaning paper with lens cleaner, and the gently wipe the their surface.

Note:

The Lens Cleaning KIT; VFK1900BK(Only supplied as 10 set/Box) is available as Service Aid.

12 Block Diagram

12.1. Overall Block Diagram

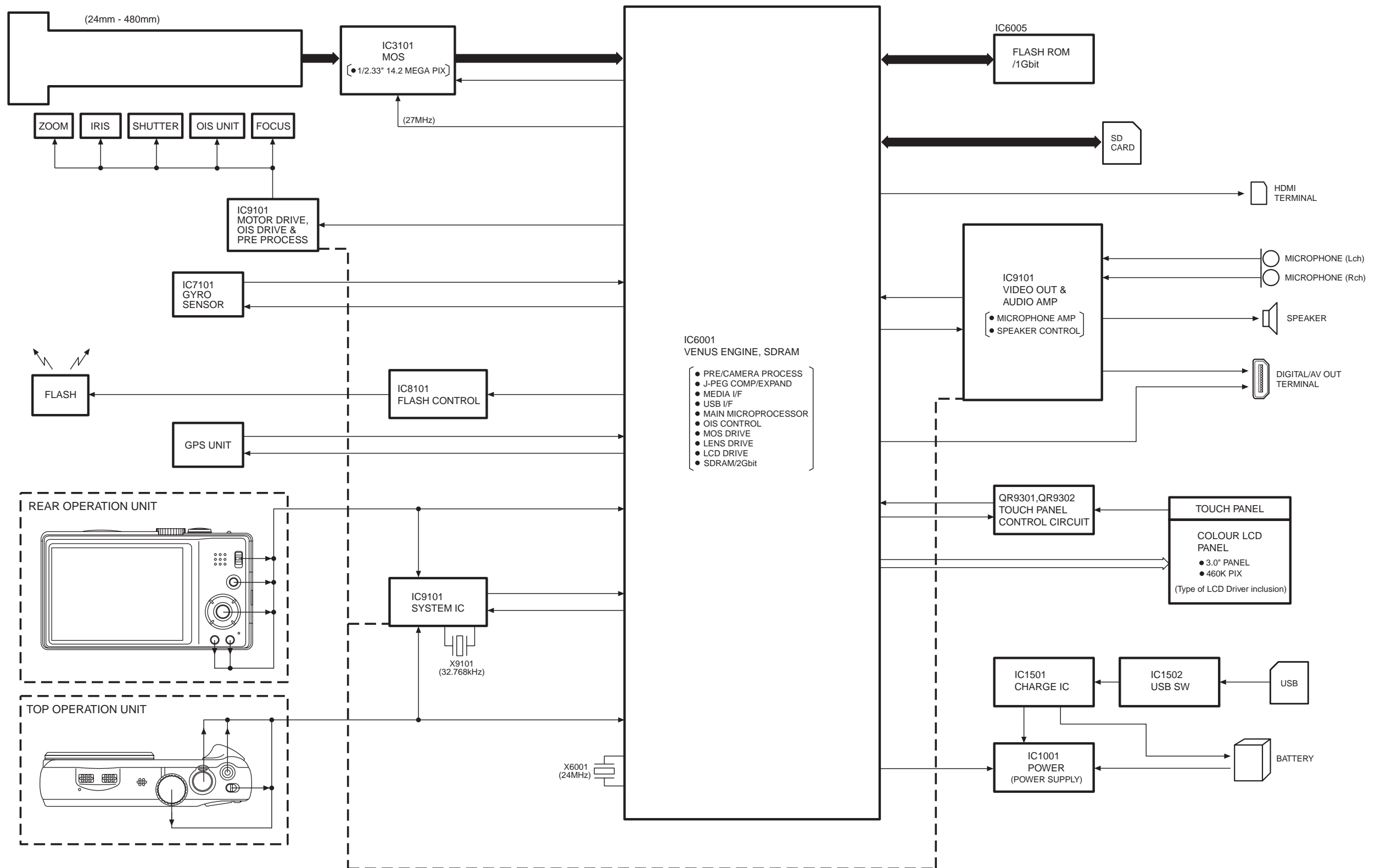

DMC-TZ27/TZ30/TZ31, ZS19/ZS20 OVERALL BLOCK DIAGRAM

12.2. System Control Block Diagram

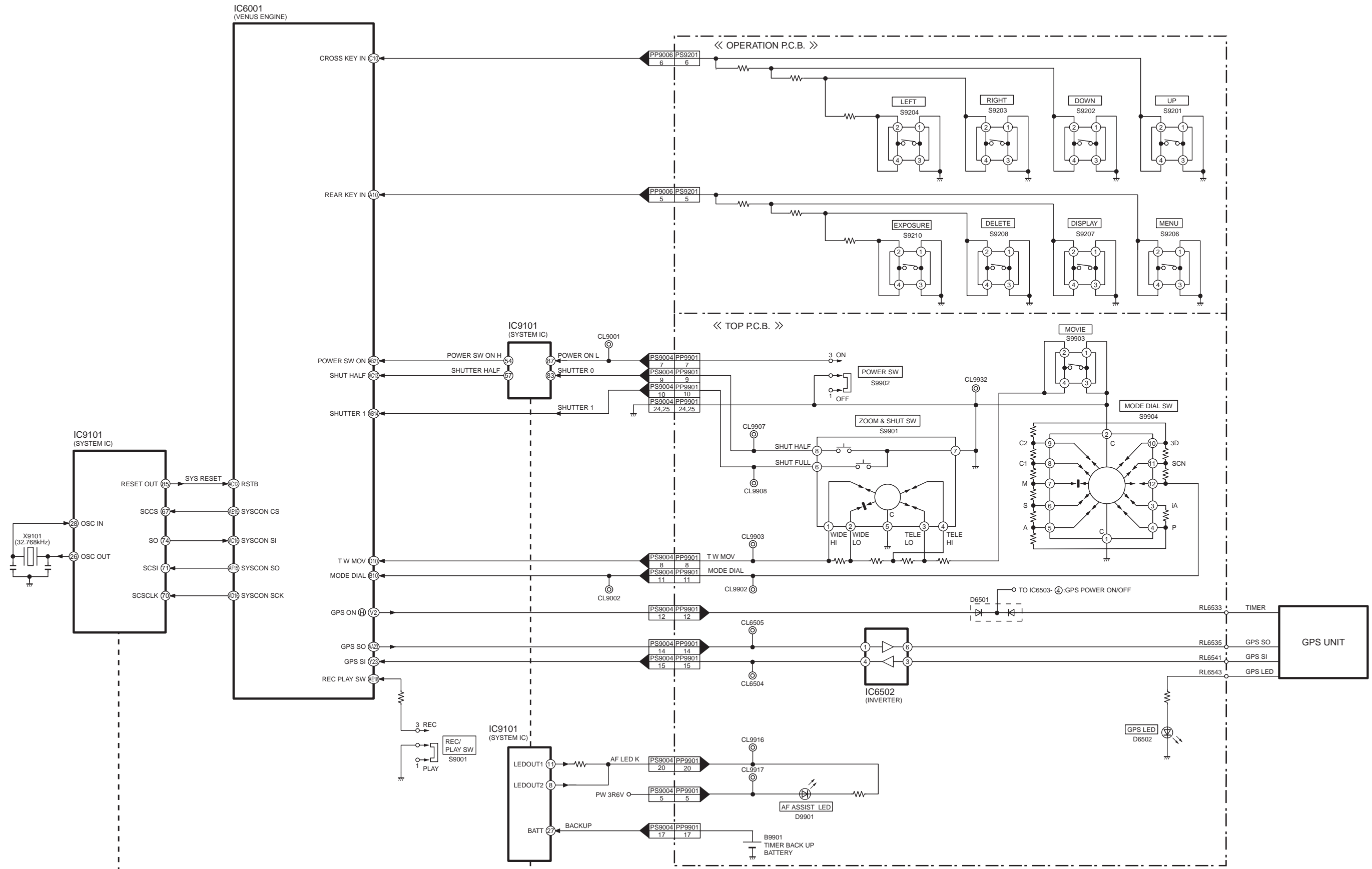

DMC-TZ27/TZ30/TZ31, ZS19/ZS20 SYSTEM CONTROL BLOCK DIAGRAM

12.3. Audio/Video Process/ HDMI Block Diagram

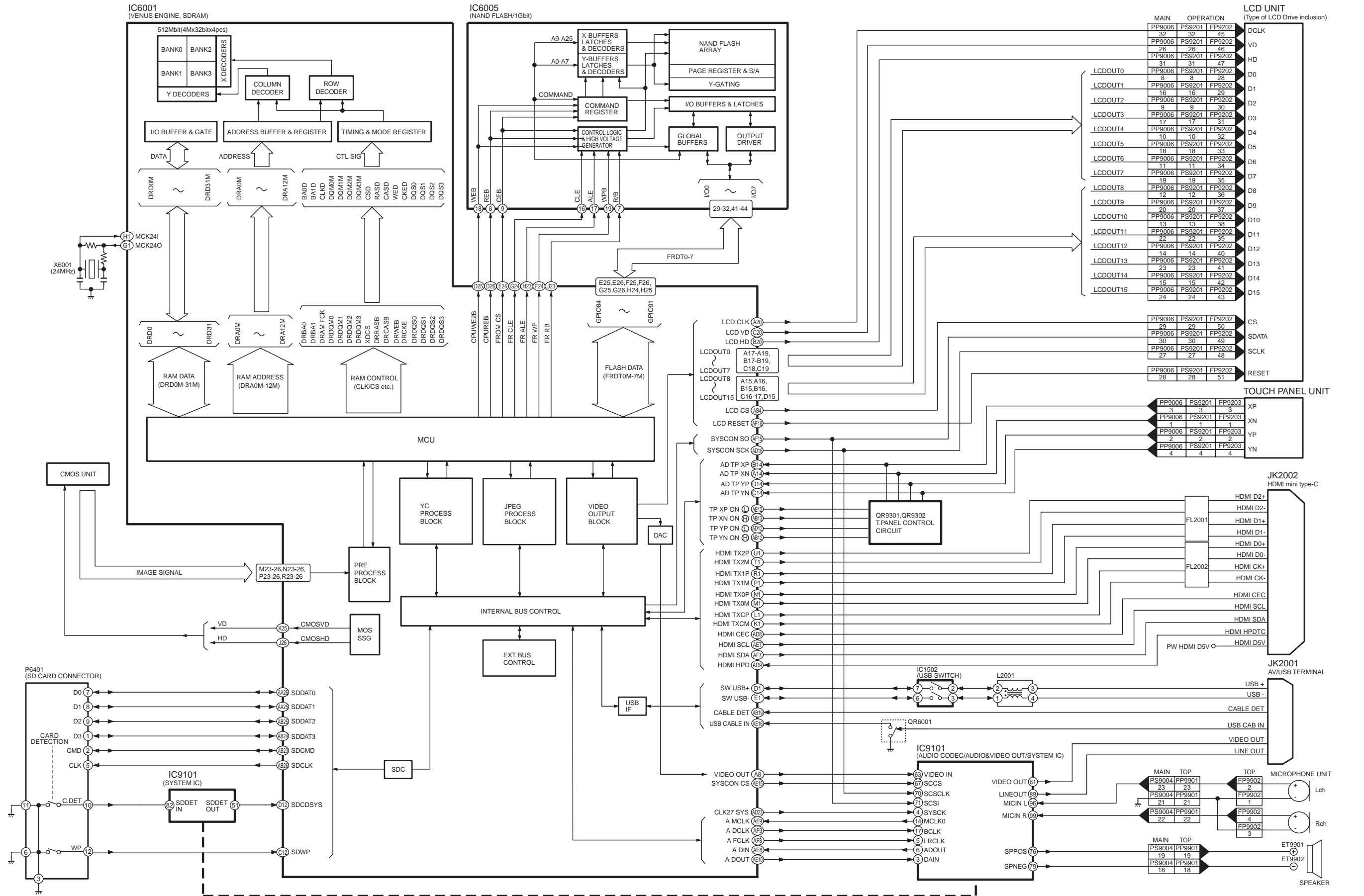

DMC-TZ27/TZ30/TZ31, ZS19/ZS20 AUDIO/VIDEO PROCESS/ HDMI BLOCK DAIGRAM

12.4. Sensor Block Diagram

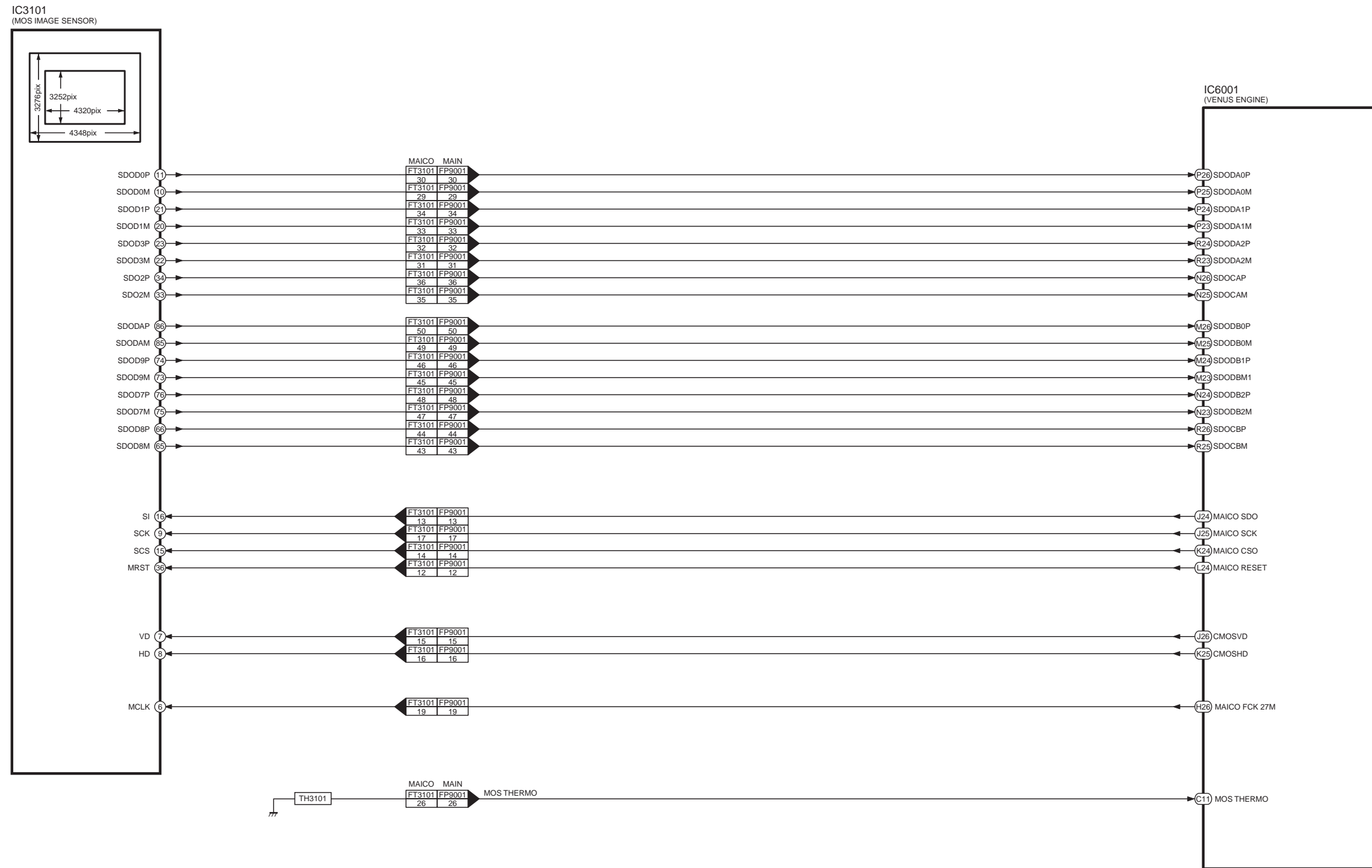

DMC-TZ27/TZ30/TZ31, ZS19/ZS20 SENSOR BLOCK DIAGRAM

12.5. Lens Drive Block Diagram

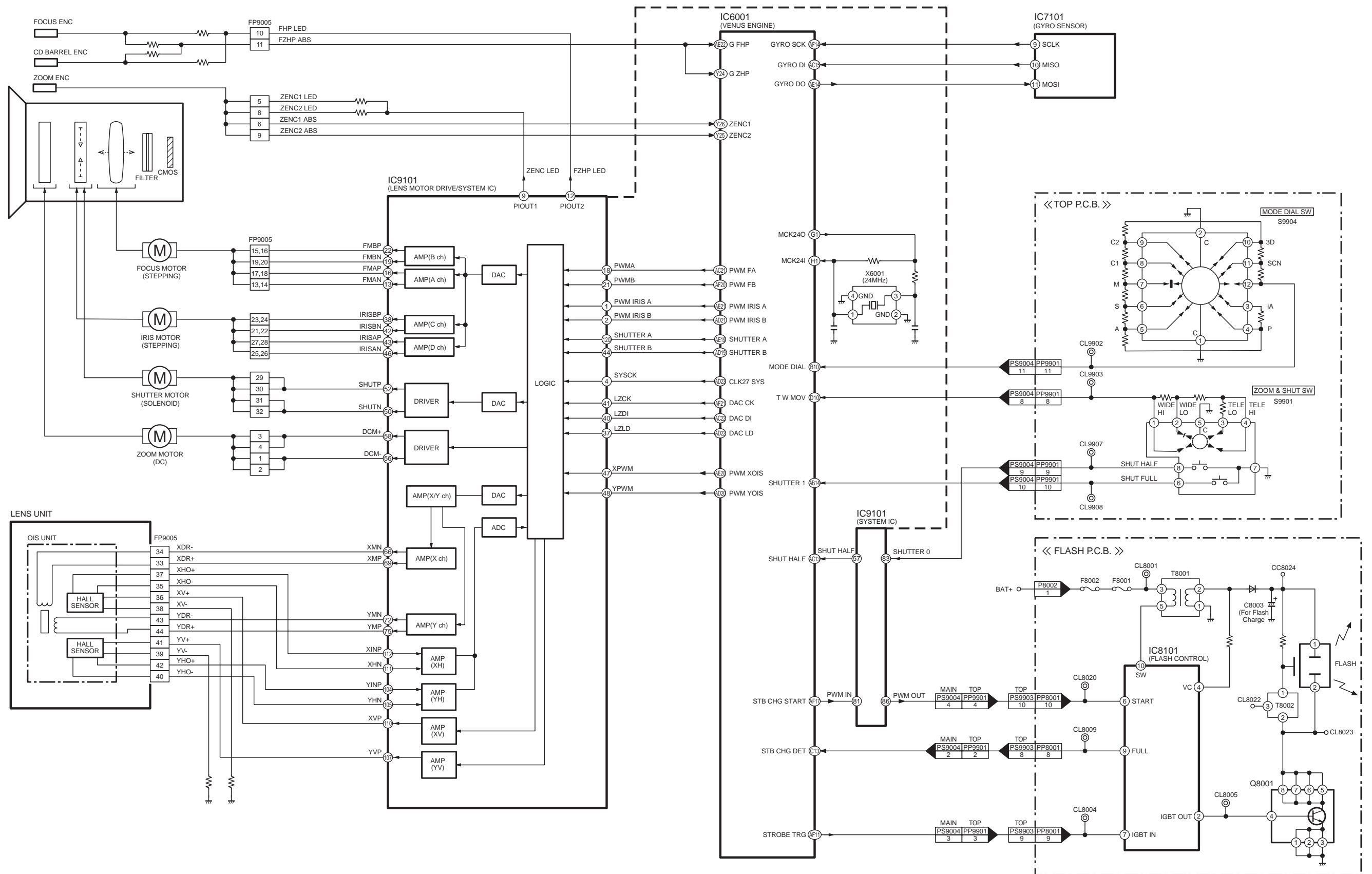

DMC-TZ27/TZ30/TZ31, ZS19/ZS20 LENS DRIVE BLOCK DIAGRAM

12.6. Power Block Diagram

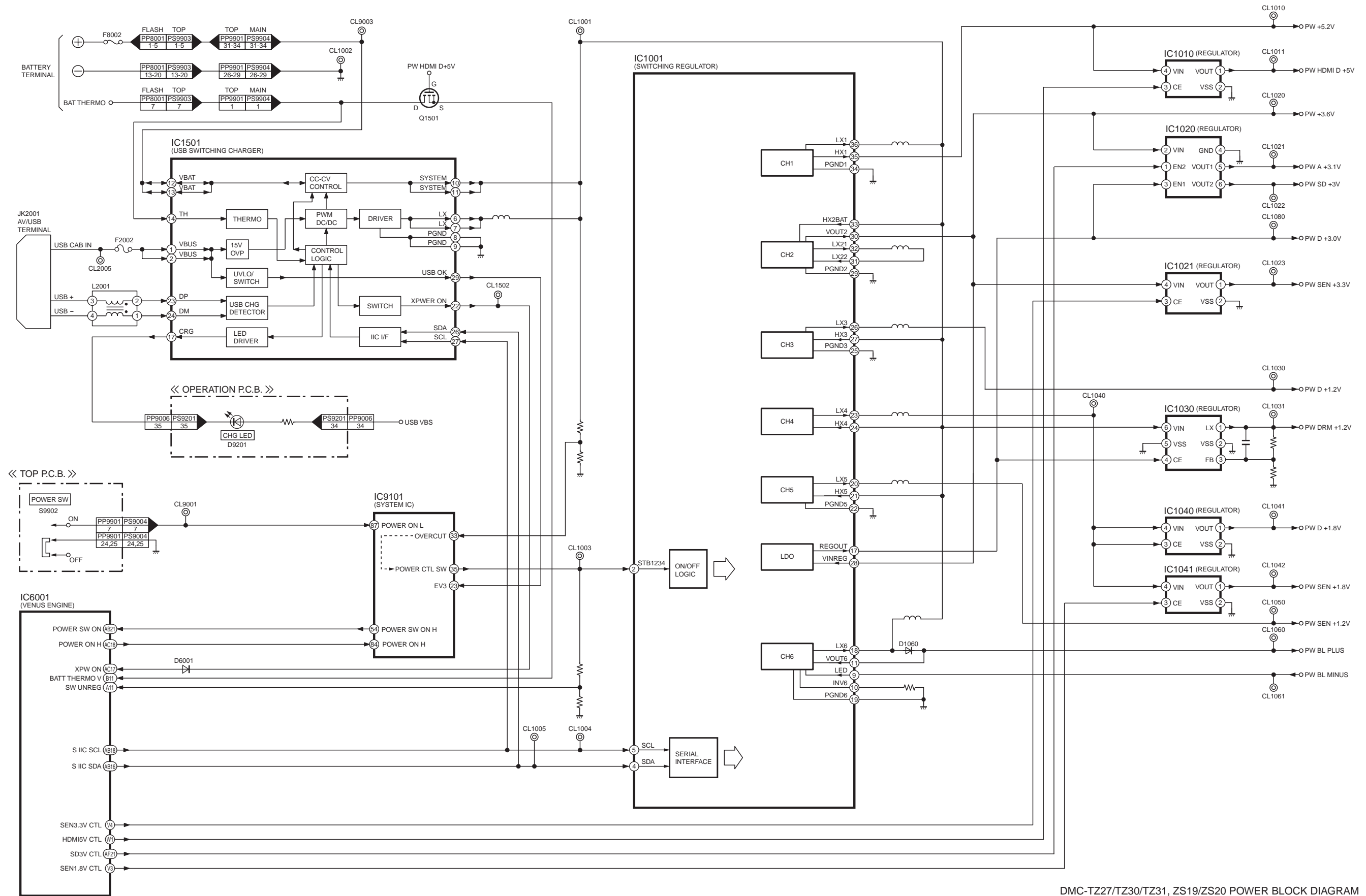

DMC-TZ27/TZ30/TZ31, ZS19/ZS20 POWER BLOCK DIAGRAM

13 Wiring Connection Diagram

13.1. Interconnection Schematic Diagram

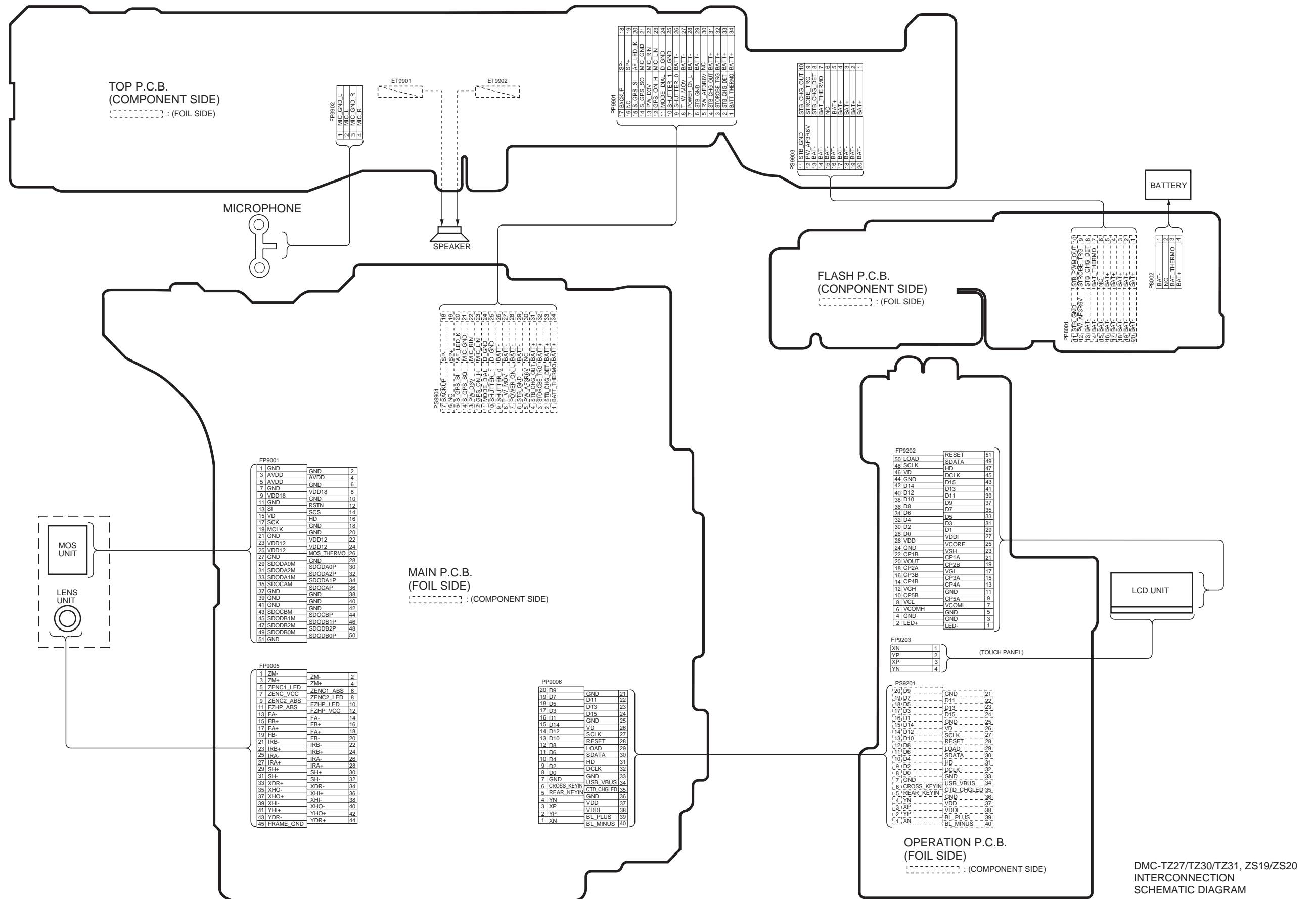

DMC-TZ27/TZ30/TZ31, ZS19/ZS20
 INTERCONNECTION
 SCHEMATIC DIAGRAM

IMPORTANT SAFETY NOTICE:

COMPONENTS IDENTIFIED WITH THE MARK ⚠ HAVE THE SPECIAL CHARACTERISTICS FOR SAFETY. WHEN REPLACING ANY OF THESE COMPONENTS USE ONLY THE SAME TYPE.

1. Although reference number of the parts is indicated on the P.C.B. drawing and/or schematic diagrams, it is NOT mounted on the P.C.B. when it is displayed with "\$" mark.
2. It is only the "Test Round" and no terminal (Pin) is available on the P.C.B. when the TP (Test Point) indicated as "●" mark.
3. Use the parts number indicated on the Replacement Parts List .
4. Indication on Schematic diagrams:

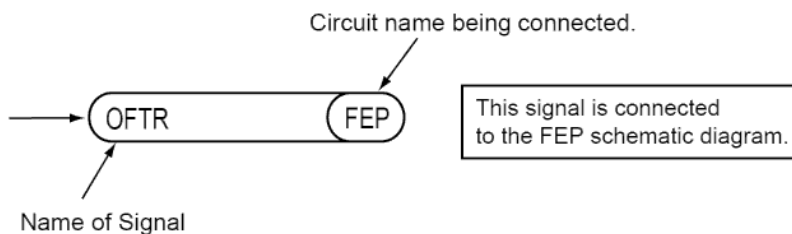

5. It might be taking time for display and/or access of the Schematic Diagrams & P. C. B having the heavy data volume.

Model No. : DMC-TZ27/TZ30/TZ31/ZS19/ZS20 Parts List Note

- Note:
- 1.* Be sure to make your orders of replacement parts according to this list.
 2. IMPORTANT SAFETY NOTICE
Components identified with the mark \triangle have the special characteristics for safety.
When replacing any of these components, use only the same type.
 3. Unless otherwise specified,
All resistors are in OHMS, K=1,000 OHMS. All capacitors are in MICRO-FARADS (uf), P=uuF.
 4. The marking (RTL) indicates the retention time is limited for this item. After the discontinuation of this assembly in production, it will no longer be available.
 5. Supply of CD-ROM, in accordance with license protection, is allowable as replacement parts only for customers who accidentally damaged or lost their own.

E.S.D. standards for Electrostatically Sensitive Devices, refer to “PREVENTION OF ELECTROSTATIC DISCHARGE (ESD) TO ELECTROSTATICALLY SENSITIVE (ES) DEVICES” section.

Definition of Parts supplier:

1. Parts marked with [ENERGY] in the remarks column are supplied from Panasonic Corporation Energy Company.
2. Parts marked with [PAVCX] in the remarks column are supplied from PAVCX.
Others are supplied from AVC-CSC-SPC.

Model No. : DMC-TZ27/TZ30/TZ31/ZS19/ZS20 Power (P) (Main P.C.B.)

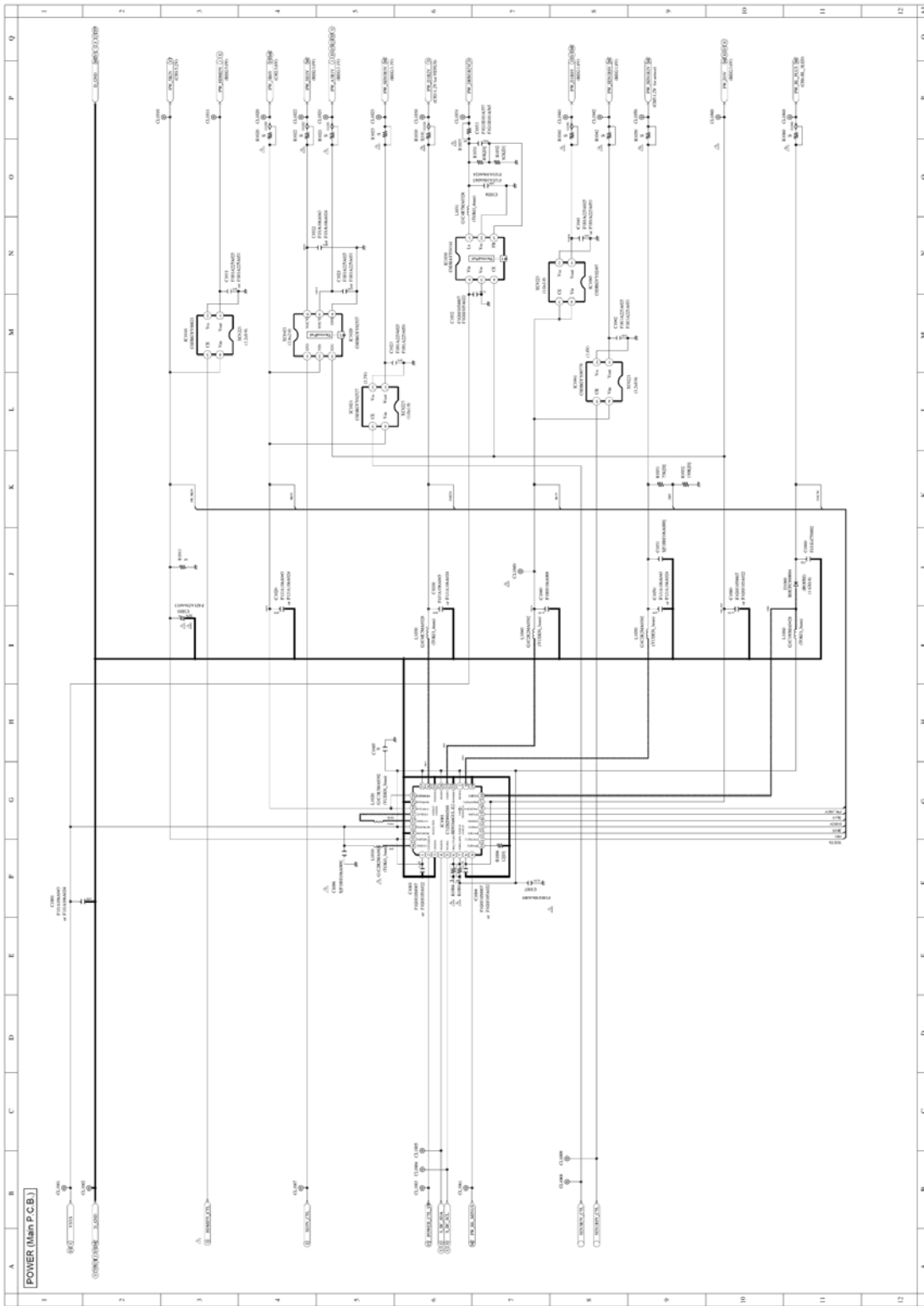

Model No. : DMC-TZ27/TZ30/TZ31/ZS19/ZS20 USB (U) (Main P.C.B.)

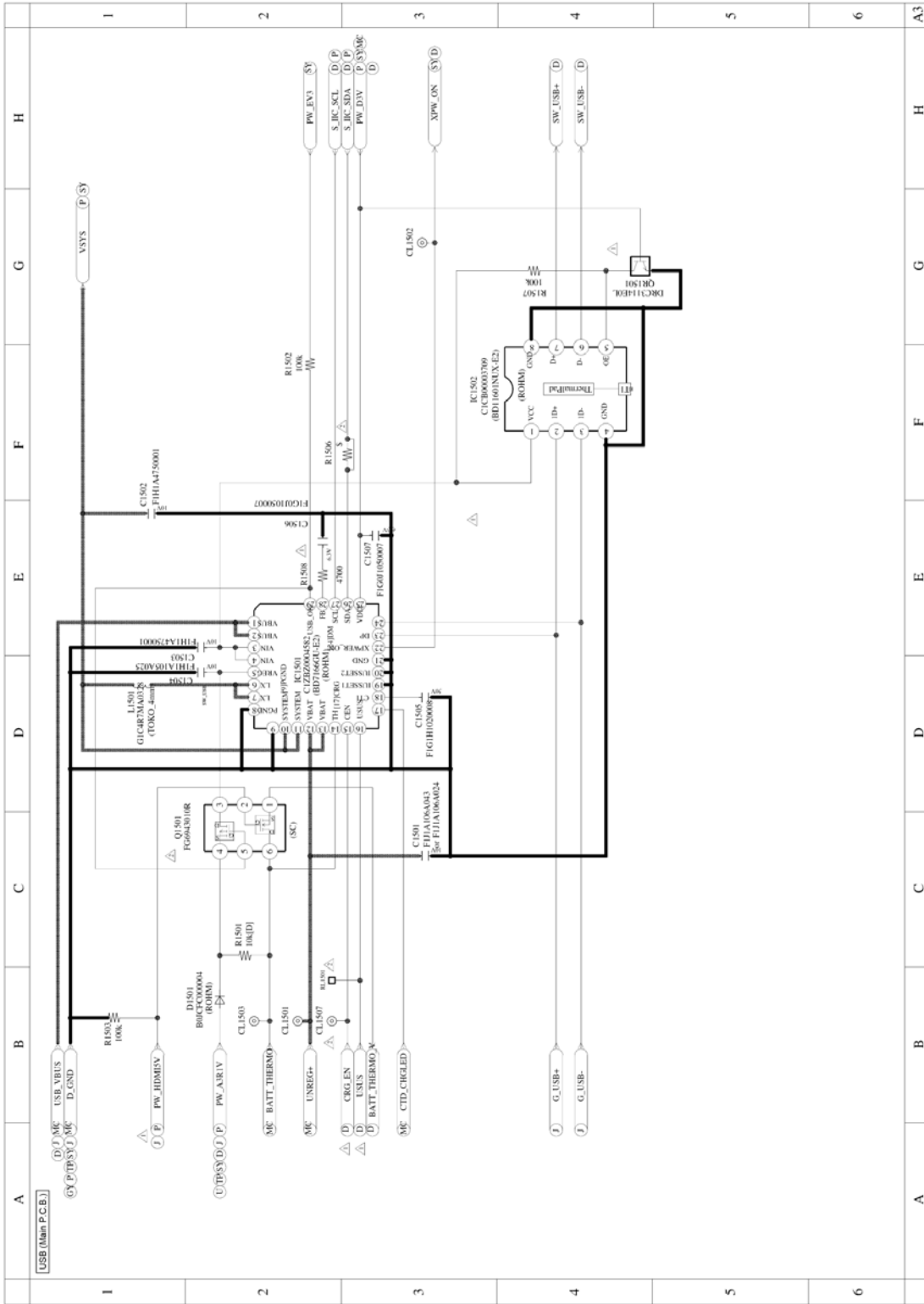

Model No. : DMC-TZ27/TZ30/TZ31/ZS19/ZS20 Jack (J) (Main P.C.B.)

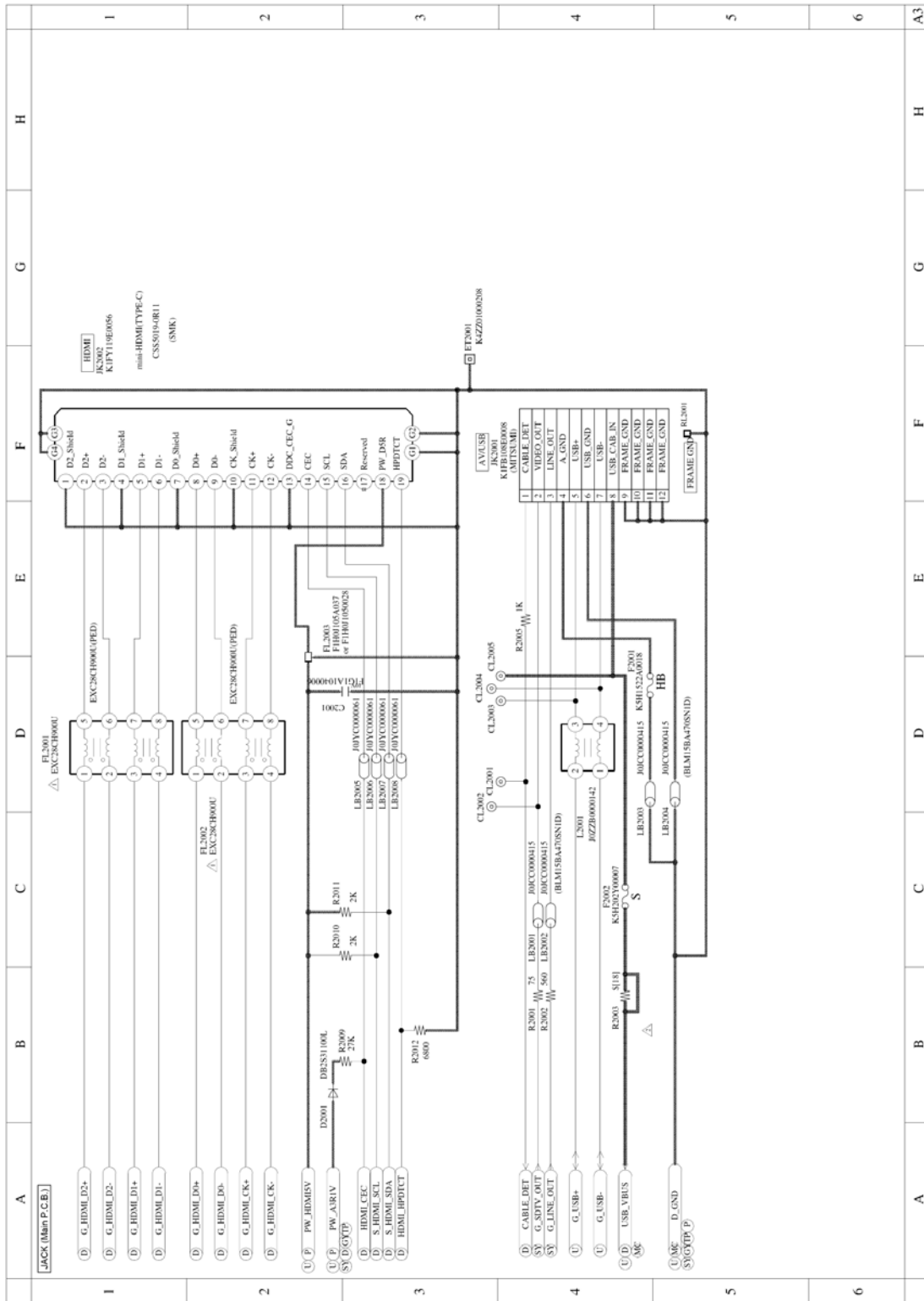

Model No. : DMC-TZ27/TZ30/TZ31/ZS19/ZS20 Digital (D) (Main P.C.B.)

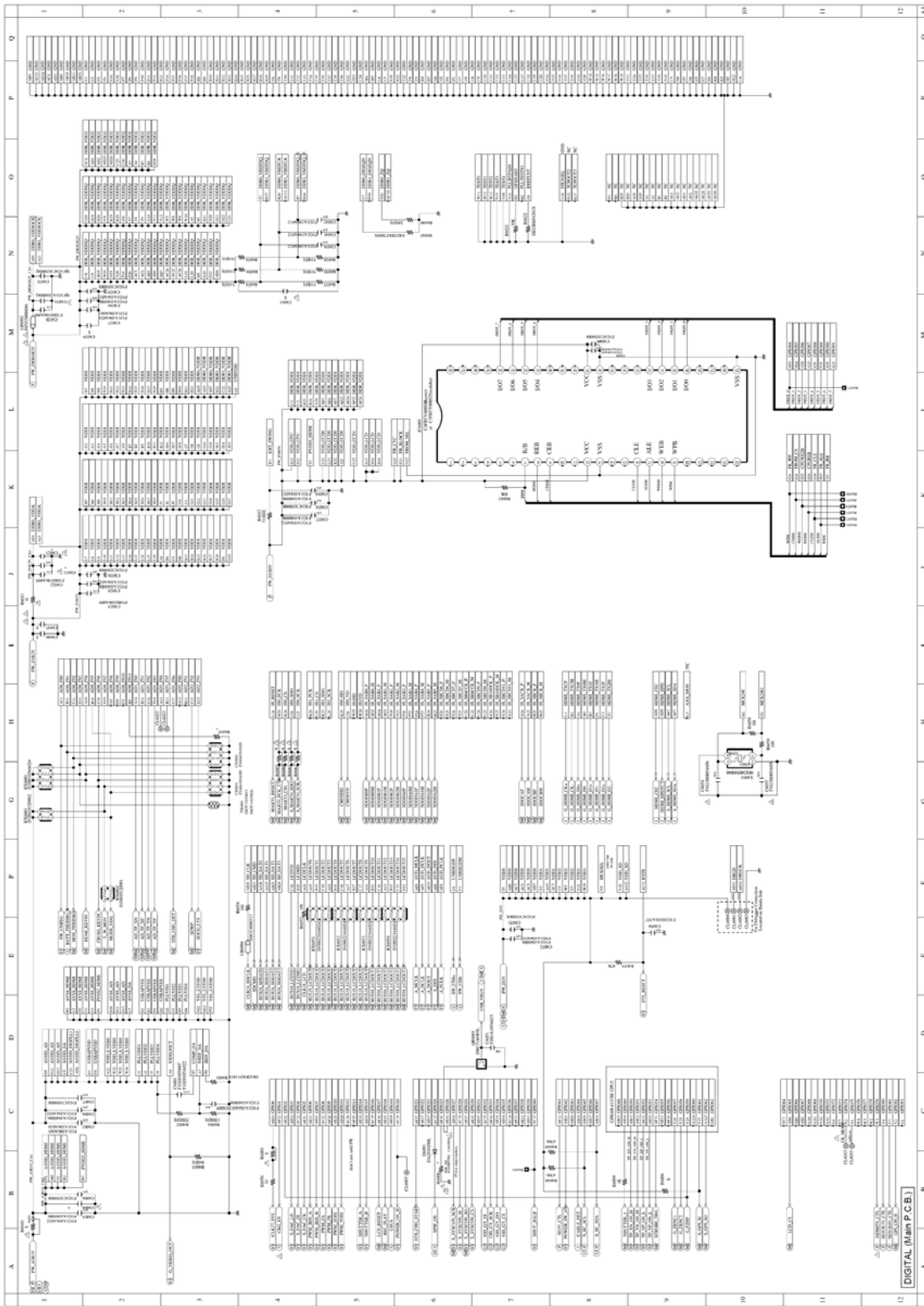

Model No. : DMC-TZ27/TZ30/TZ31/ZS19/ZS20 Gyro (GY) (Main P.C.B.)

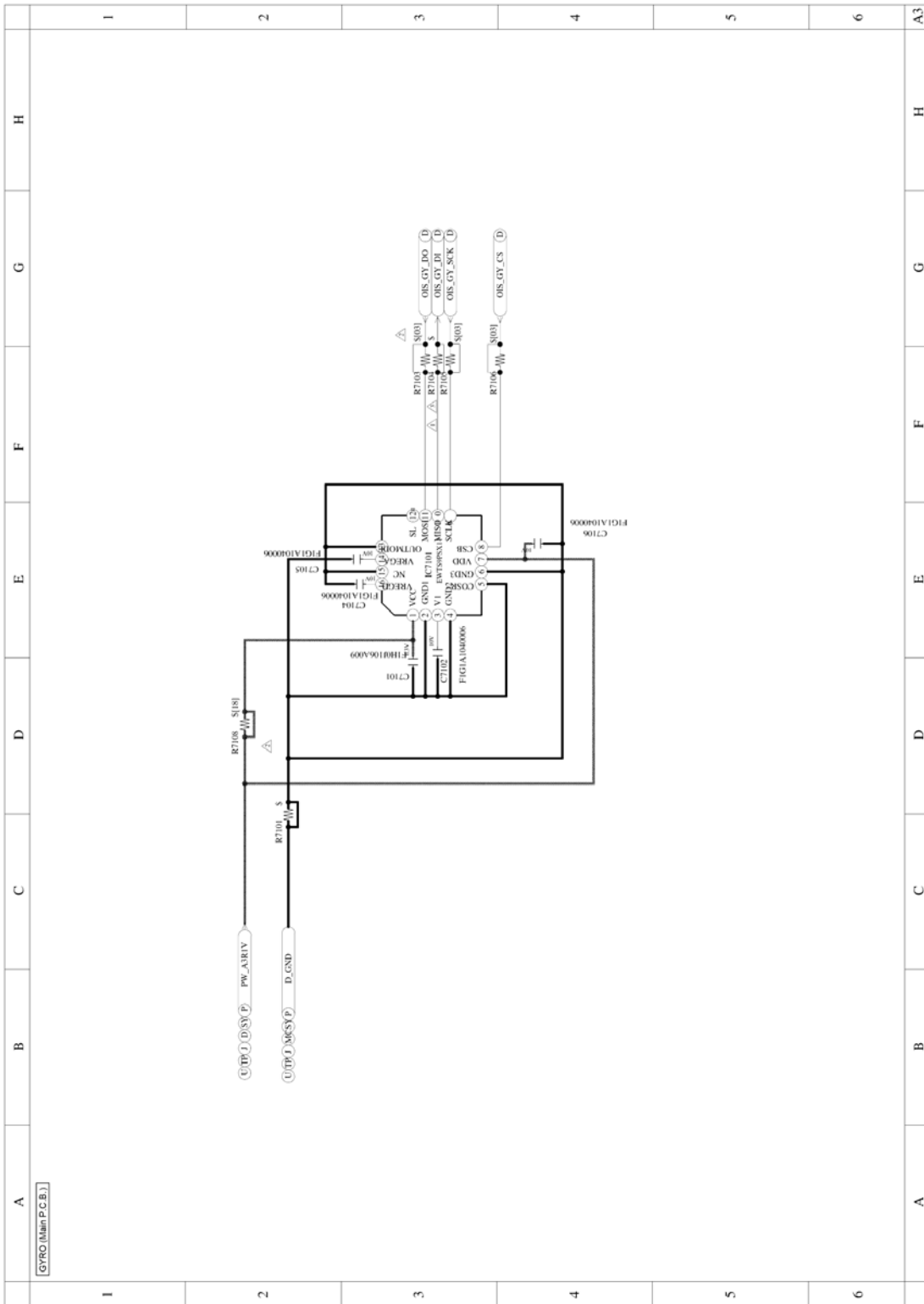

Model No. : DMC-TZ27/TZ30/TZ31/ZS19/ZS20 System Driver (SY) (Main P.C.B.)

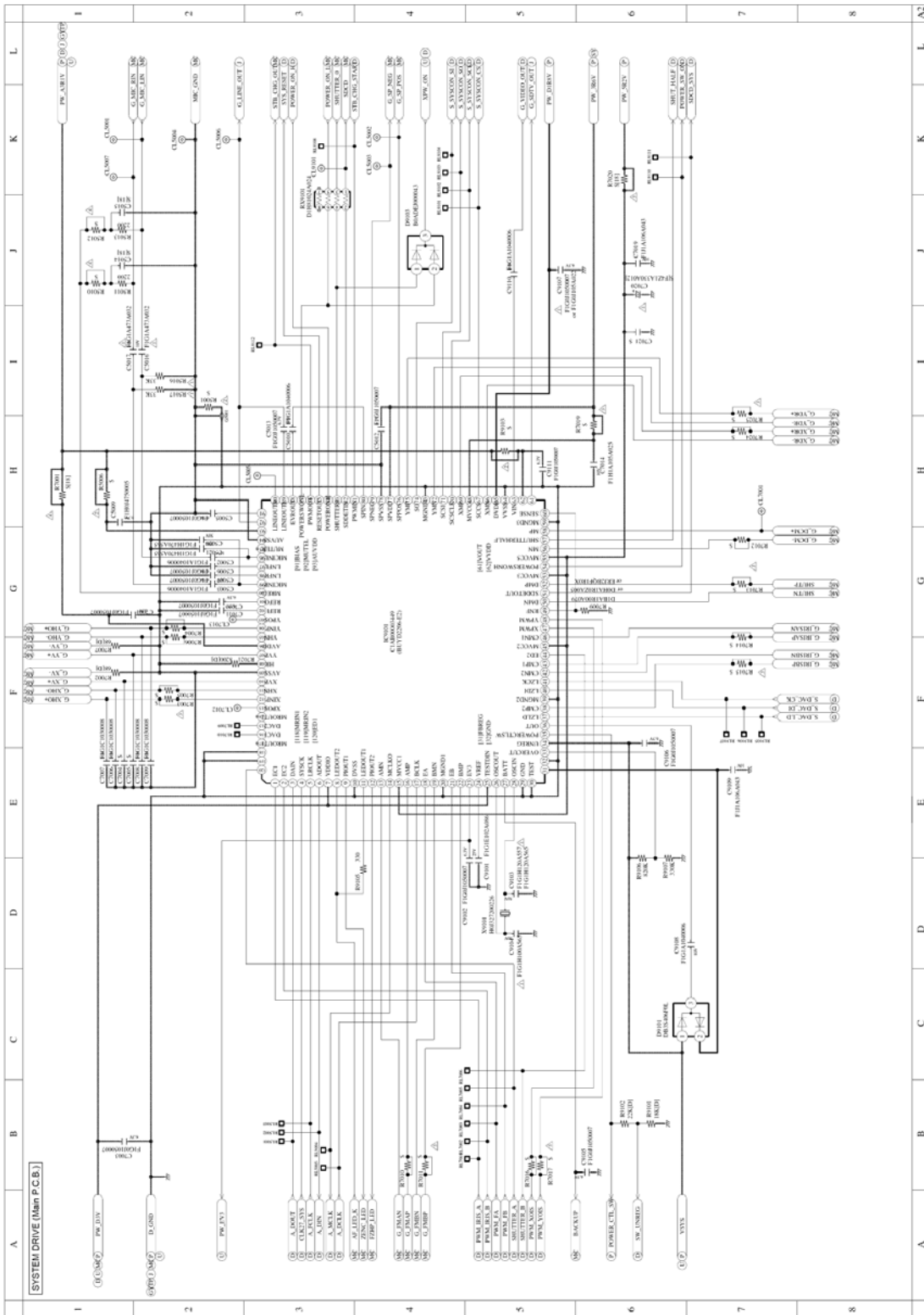

Model No. : DMC-TZ27/TZ30/TZ31/ZS19/ZS20 Touch Panel (TP) (Main P.C.B.)

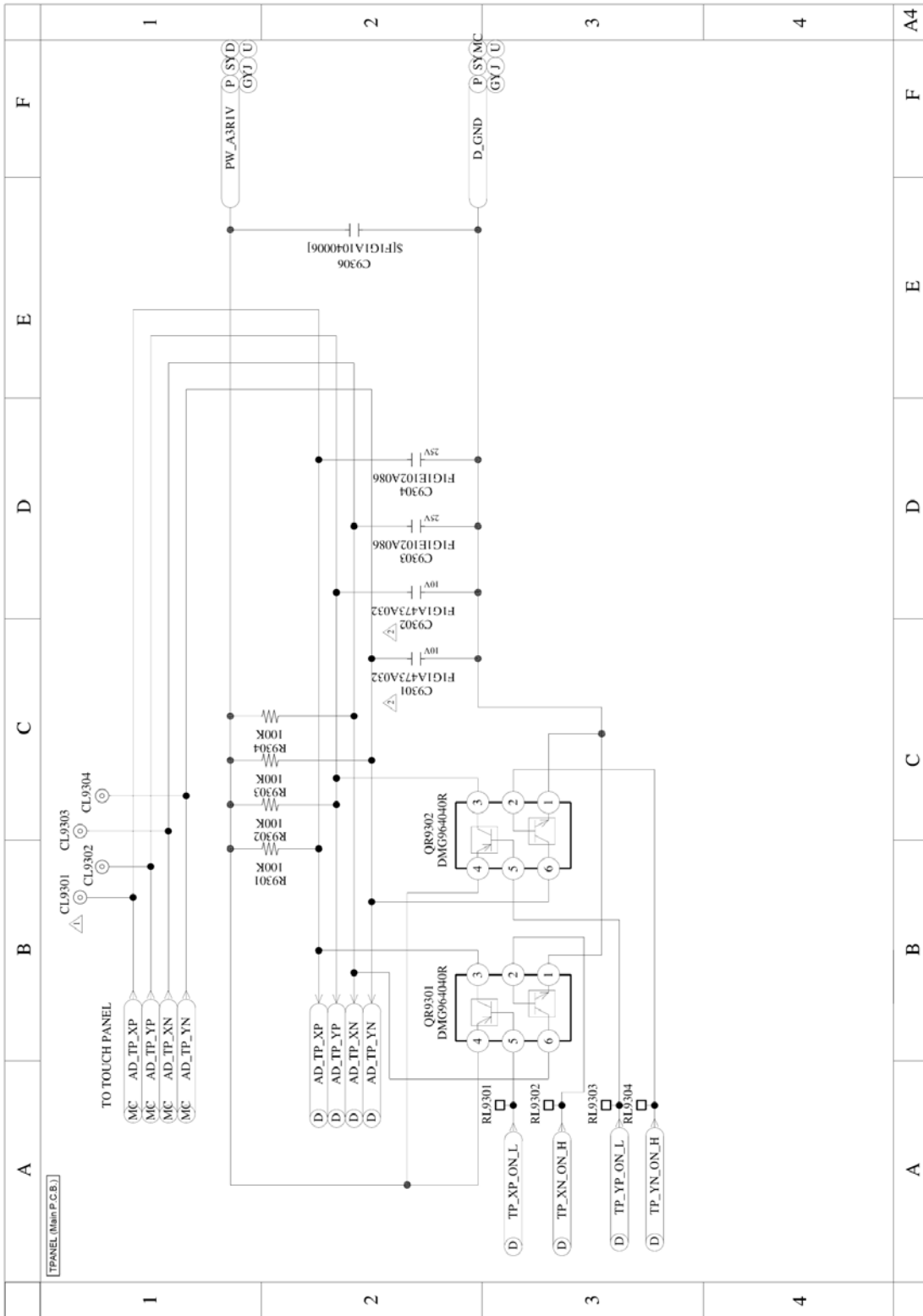

Model No. : DMC-TZ27/TZ30/TZ31/ZS19/ZS20 Main Connection (MC) (Main P.C.B.)

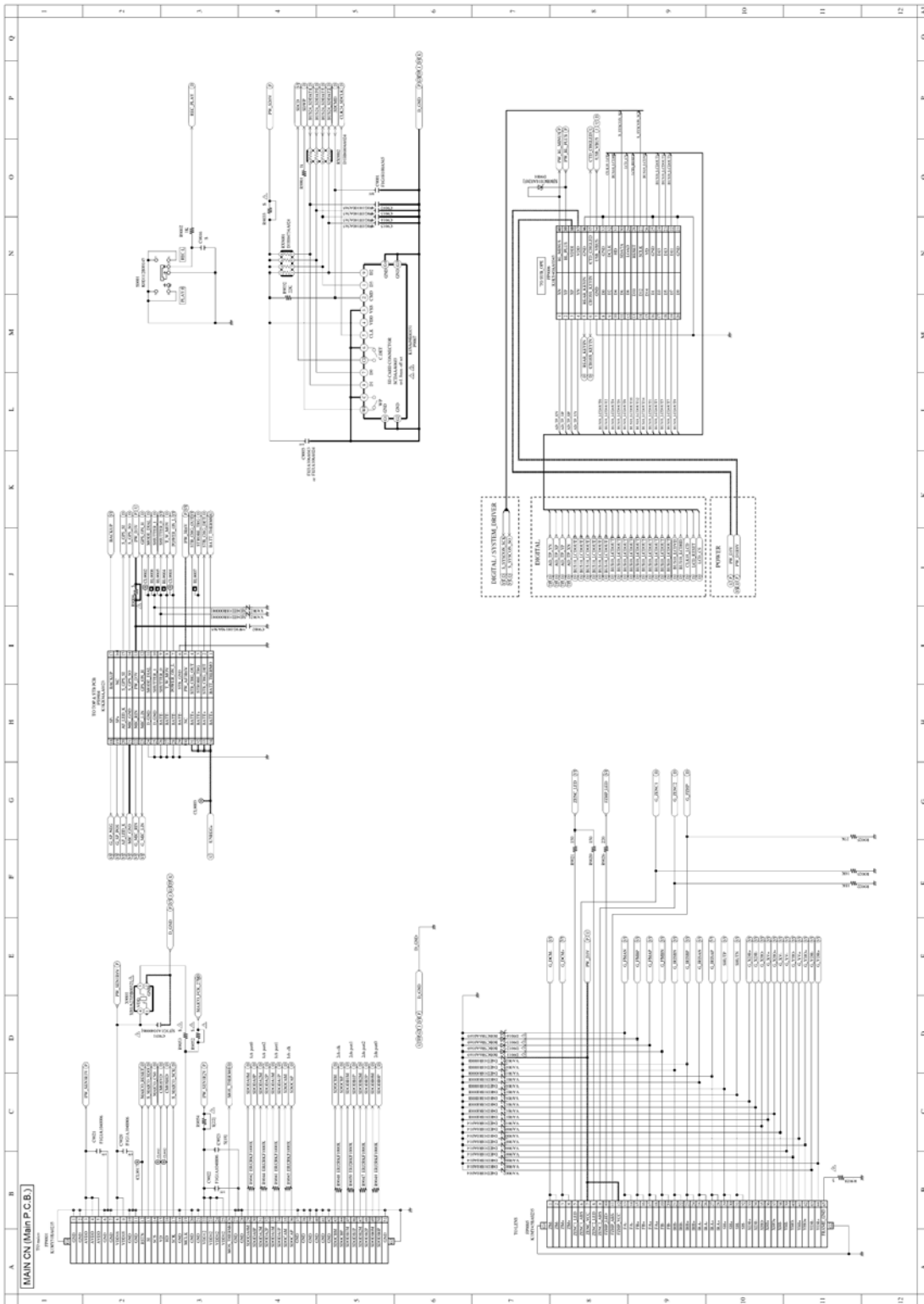

Model No. : DMC-TZ27/TZ30/TZ31/ZS19/ZS20 Rear Operation (Operation P.C.B.)

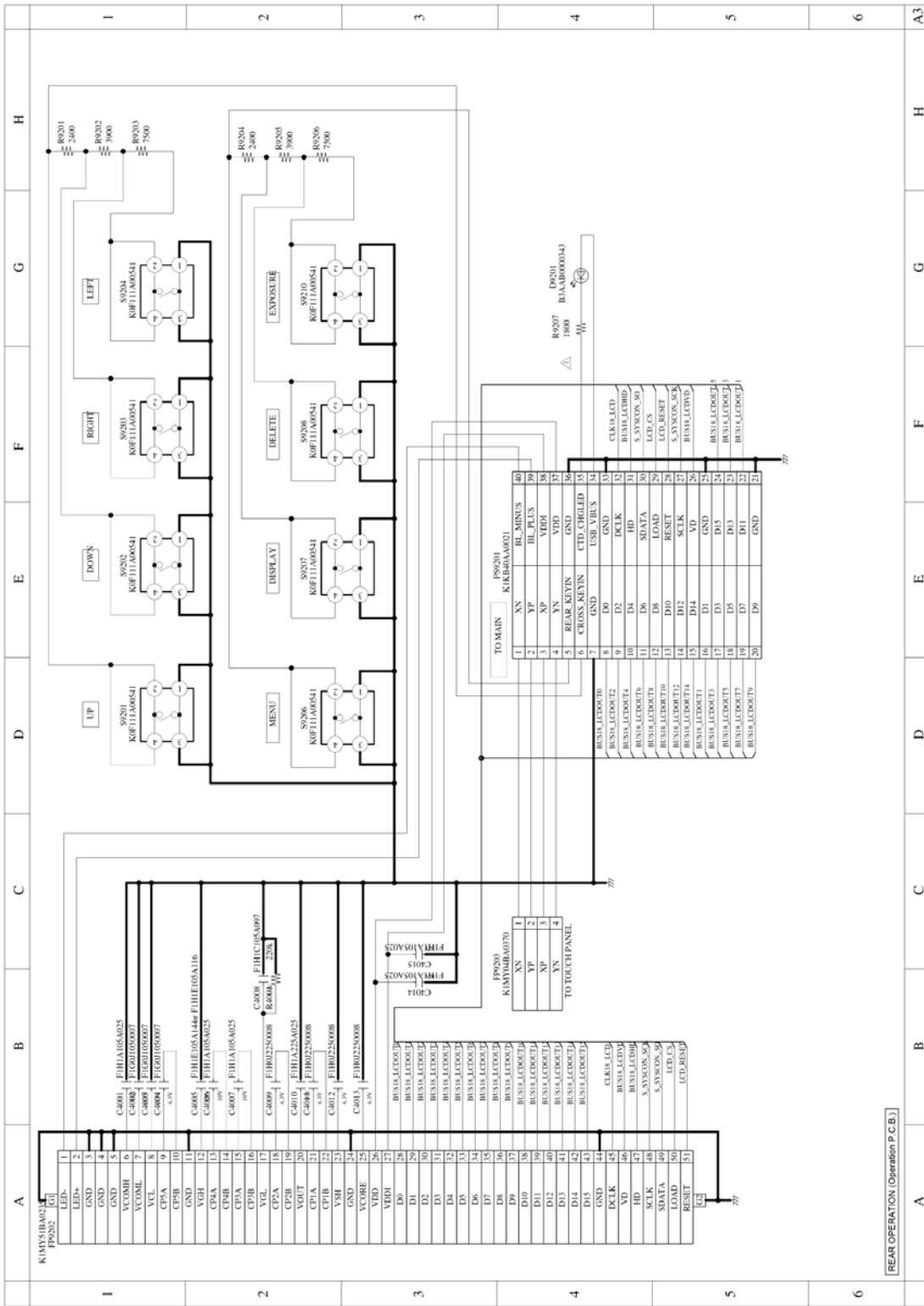

REAR OPERATION (Operation P.C.B.)

Model No. : DMC-TZ27/TZ30/TZ31/ZS19/ZS20 Flash (Flash P.C.B.)

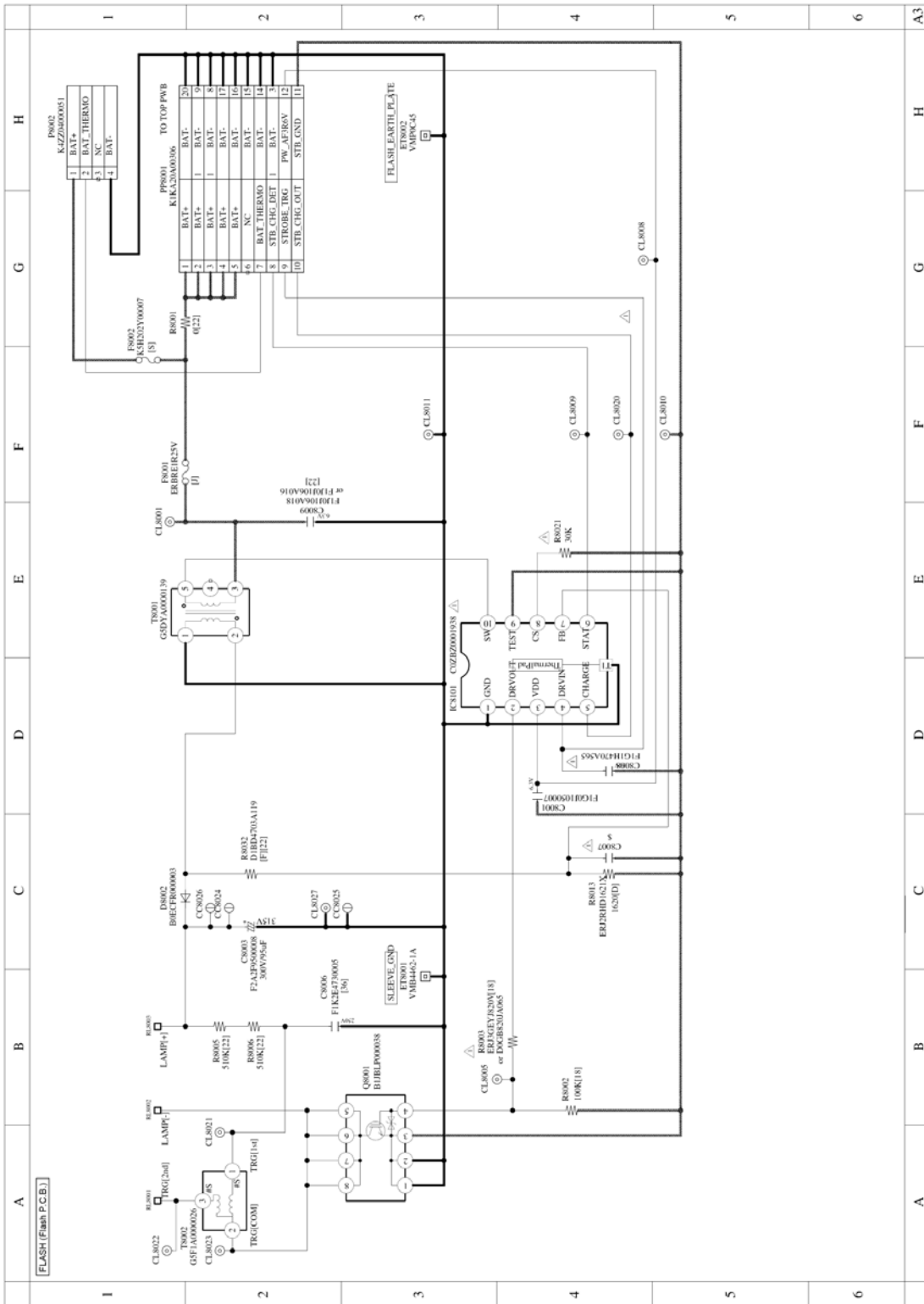

Model No. : DMC-TZ27/TZ30/TZ31/ZS19/ZS20 Top (T) (Top P.C.B.)

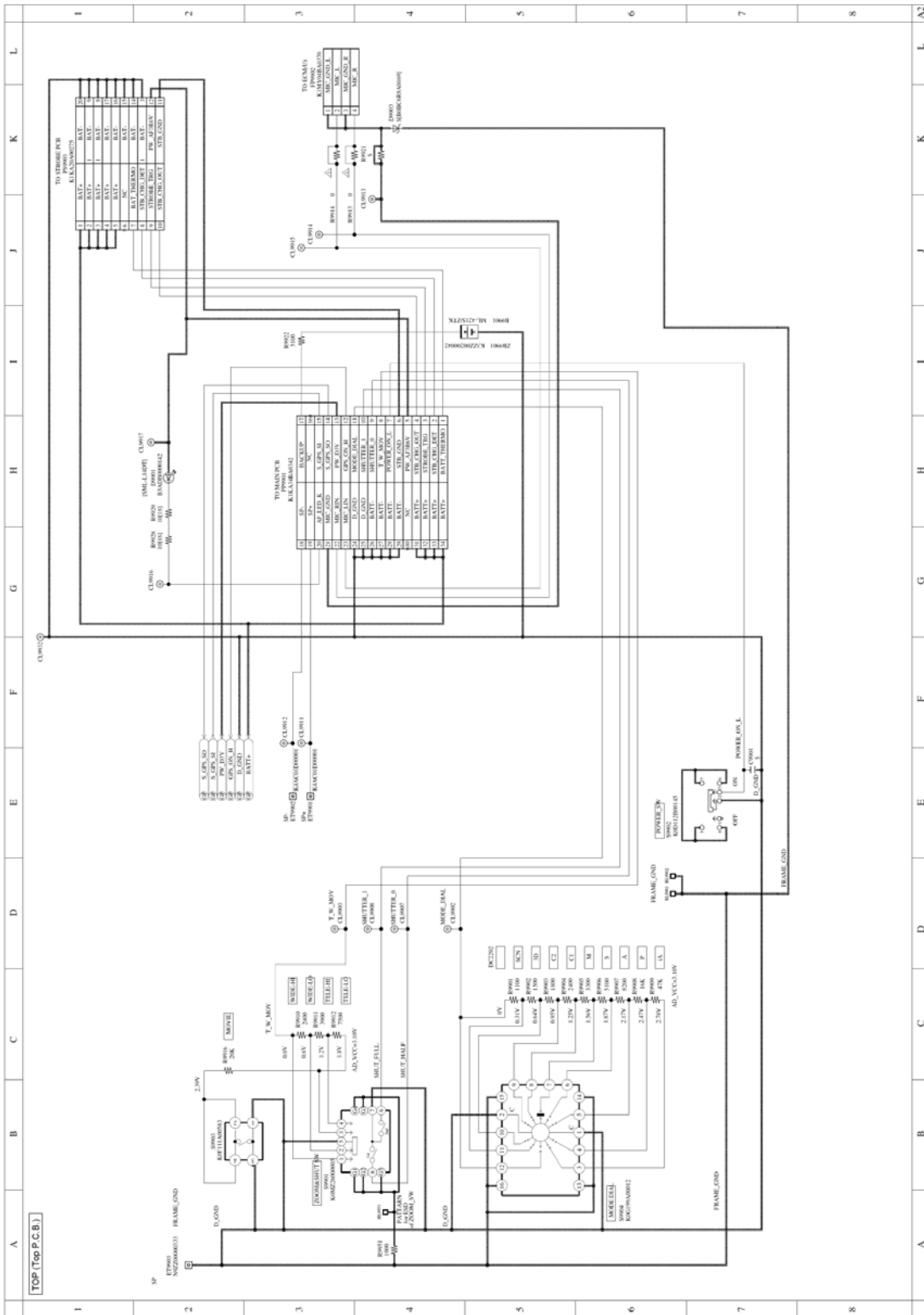

Model No. : DMC-TZ27/TZ30/TZ31/ZS19/ZS20 GPS (GP) (Top P.C.B.)

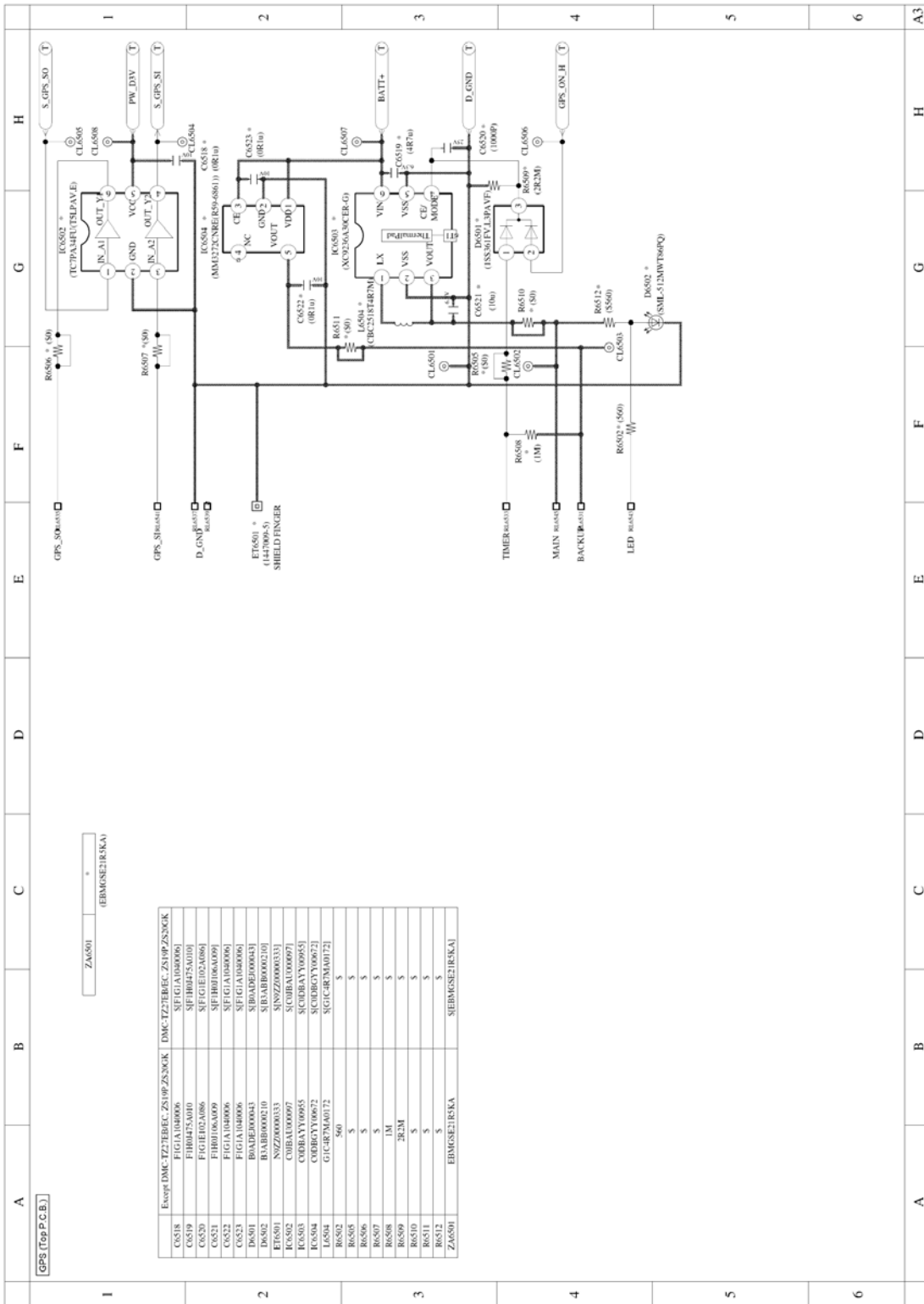

Model No. : DMC-TZ27/TZ30/TZ31/ZS19/ZS20 Main P.C.B. (Component Side)

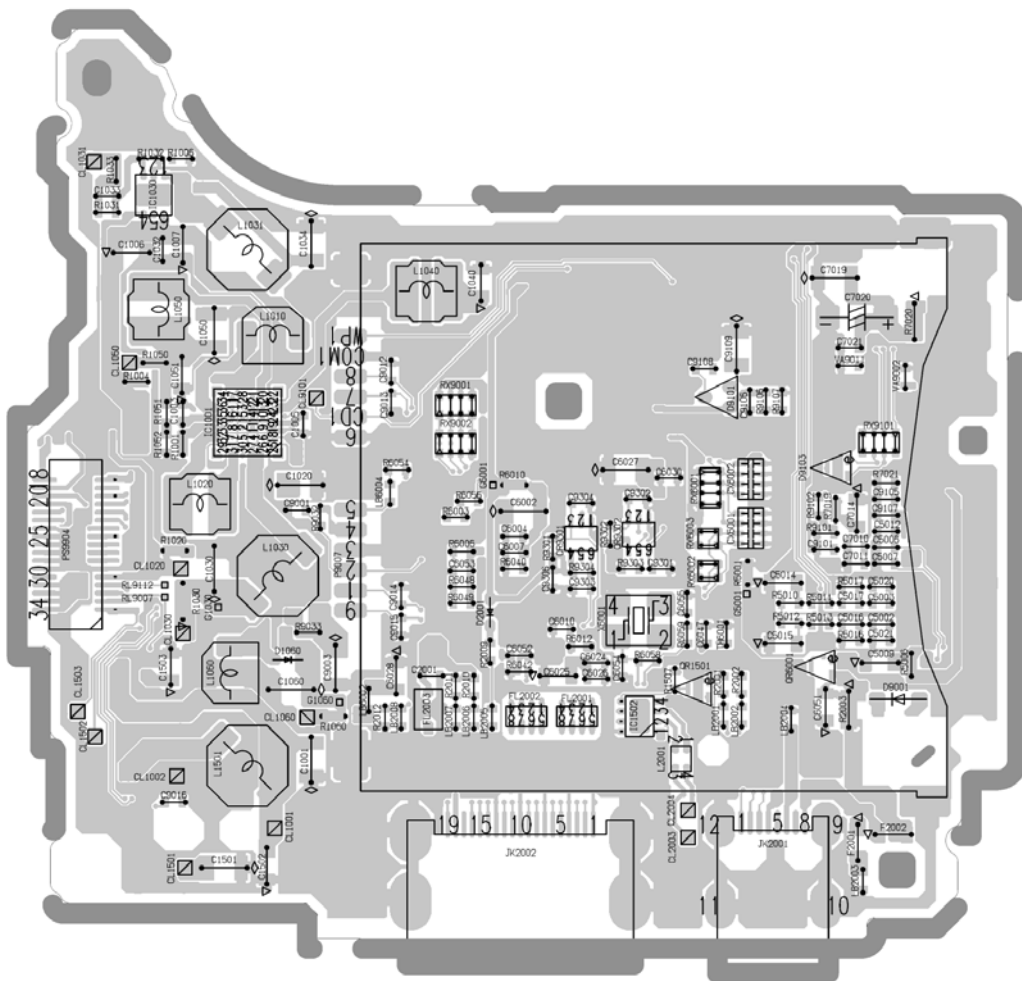

Model No. : DMC-TZ27/TZ30/TZ31/ZS19/ZS20 Main P.C.B. (Foil Side)

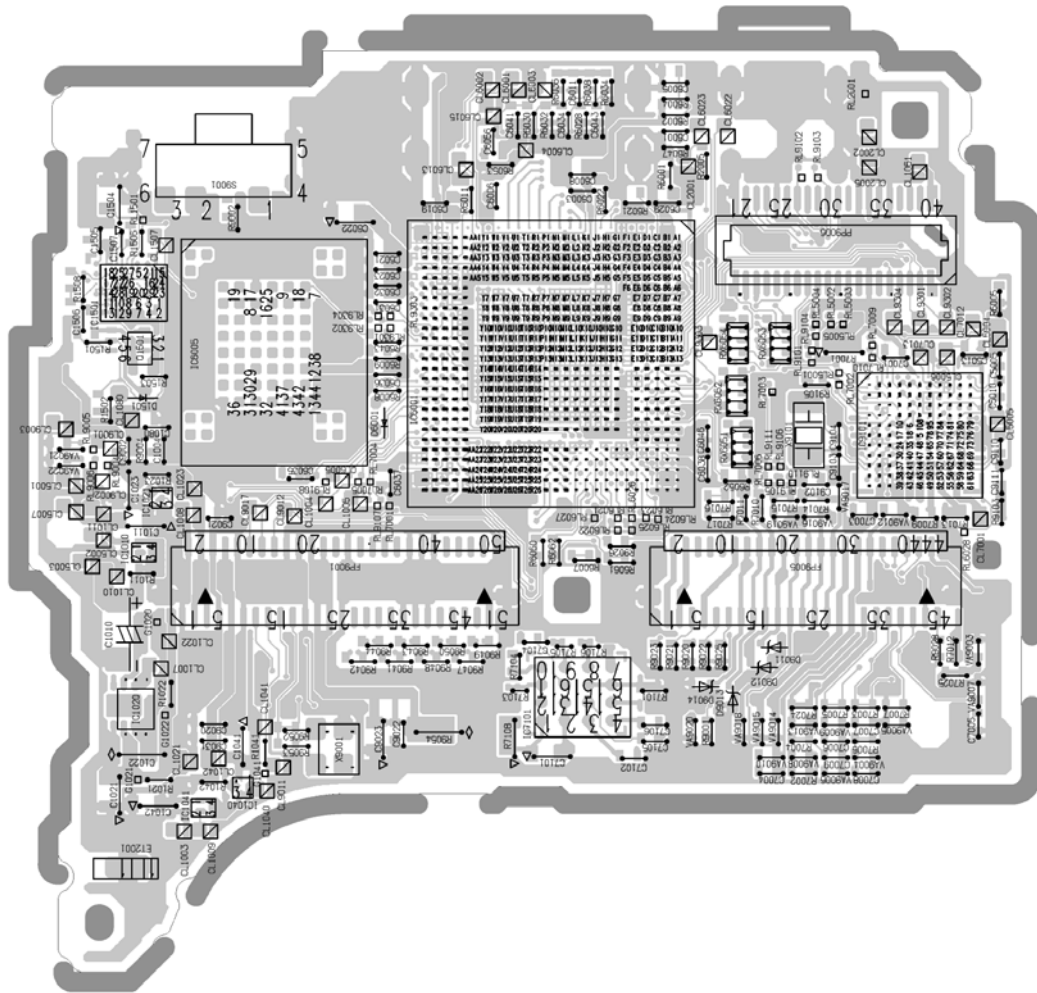

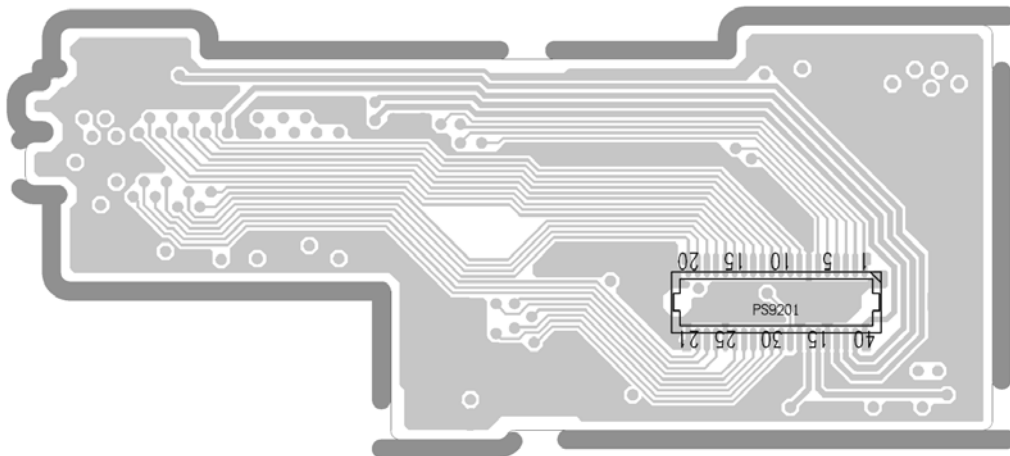

Model No. : DMC-TZ27/TZ30/TZ31/ZS19/ZS20 Operation P.C.B. (Foil Side)

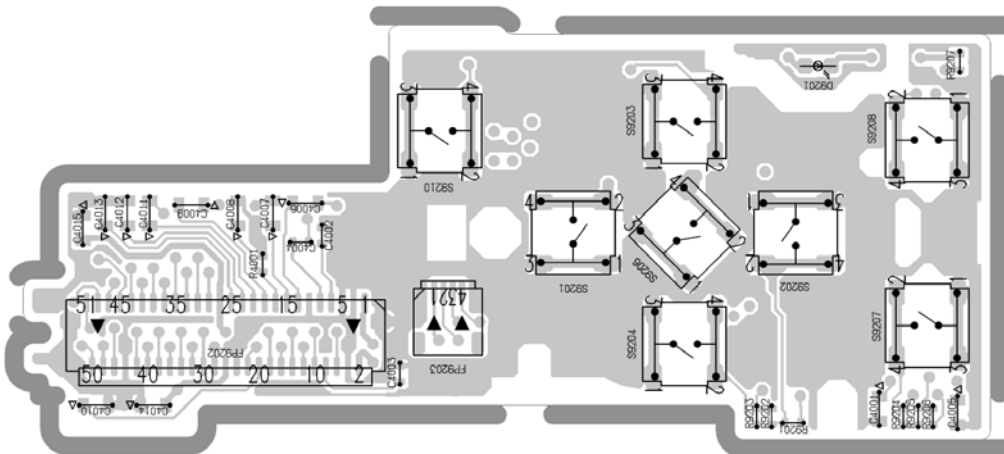

Model No. : DMC-TZ27/TZ30/TZ31/ZS19/ZS20 Flash P.C.B. (Component Side)

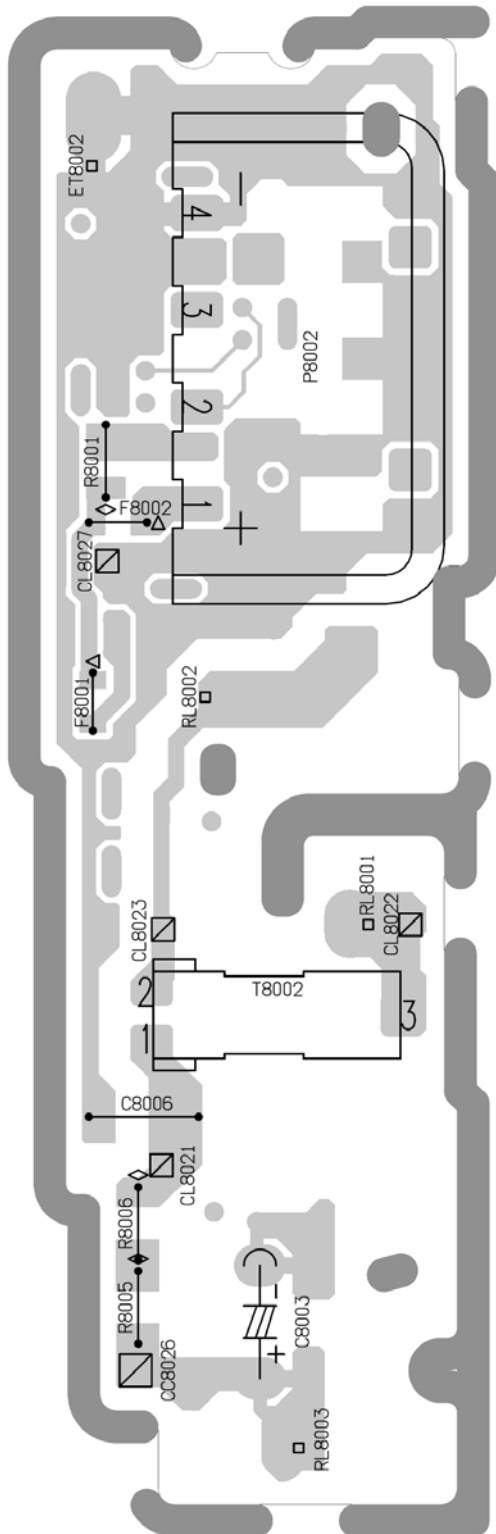

Model No. : DMC-TZ27/TZ30/TZ31/ZS19/ZS20 Flash P.C.B. (Foil Side)

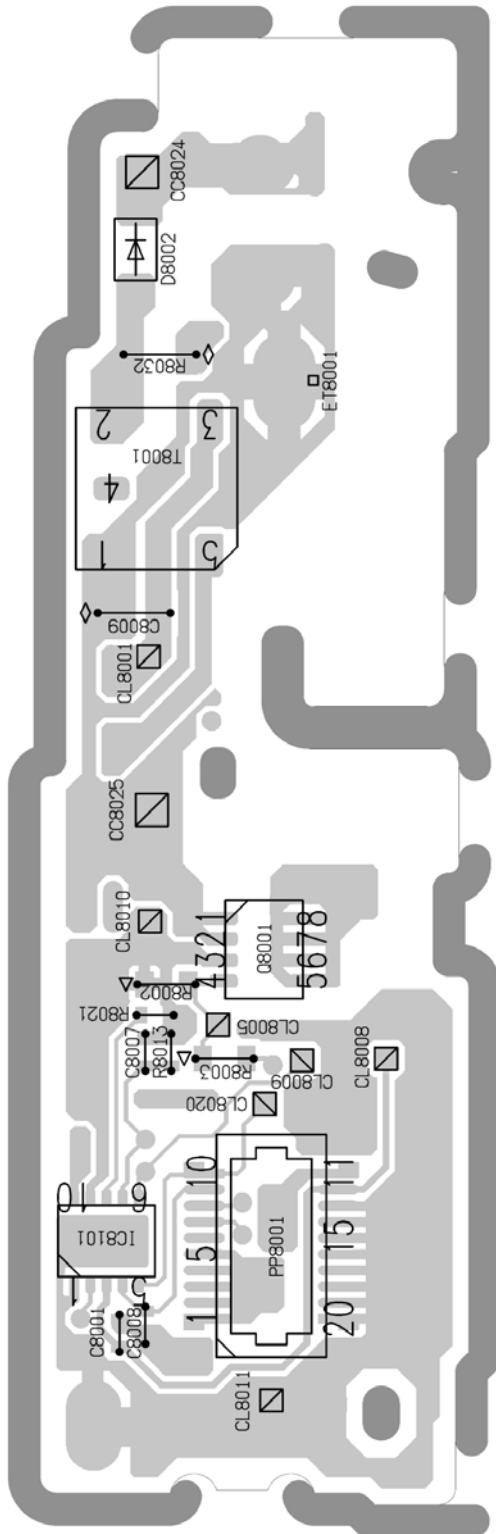

Model No. : DMC-TZ27/TZ30/TZ31/ZS19/ZS20 Top P.C.B. (Component Side)

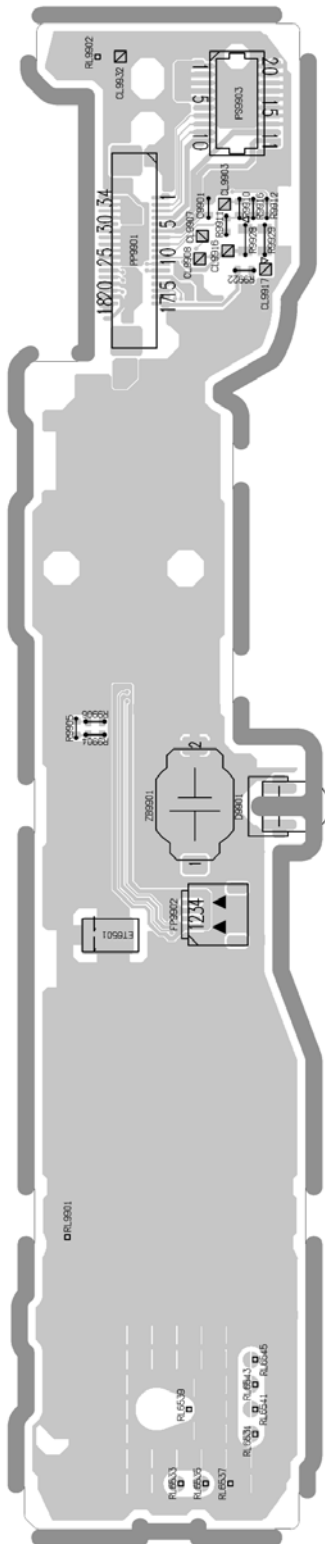

Model No. : DMC-TZ27/TZ30/TZ31/ZS19/ZS20 Parts List

Safety	Ref. No.	Part No.	Part Name & Description	Q'ty	Remarks
	C1001	F1J1A106A043	C.CAPACITOR CH 10V 10U	1	
	C1003	FIG0J1050007	C.CAPACITOR CH 6.3V 1U	1	
	C1004	FIG0J1050007	C.CAPACITOR CH 6.3V 1U	1	
	C1007	F1H0J106A009	C.CAPACITOR CH 6.3V 10U	1	
	C1010	F4Z1A336A013	C.CAPACITOR CH 10V 33U	1	
	C1011	F1H1A225A025	C.CAPACITOR CH 10V 2.2U	1	
	C1020	F1J1A106A043	C.CAPACITOR CH 10V 10U	1	
	C1021	F1H1A225A025	C.CAPACITOR CH 10V 2.2U	1	
	C1022	F1J1A106A043	C.CAPACITOR CH 10V 10U	1	
	C1023	F1H1A225A025	C.CAPACITOR CH 10V 2.2U	1	
	C1030	F1J1A106A043	C.CAPACITOR CH 10V 10U	1	
	C1032	FIG0J1050007	C.CAPACITOR CH 6.3V 1U	1	
	C1033	FIG1H101A557	C.CAPACITOR CH 50V 100P	1	
	C1034	F1J1A106A043	C.CAPACITOR CH 10V 10U	1	
	C1040	F1H0J106A009	C.CAPACITOR CH 6.3V 10U	1	
	C1041	F1H1A225A025	C.CAPACITOR CH 10V 2.2U	1	
	C1042	F1H1A225A025	C.CAPACITOR CH 10V 2.2U	1	
	C1050	F1J1A106A043	C.CAPACITOR CH 10V 10U	1	
	C1060	F1J1E4750002	C.CAPACITOR CH 25V 4.7U	1	
	C1080	FIG0J1050007	C.CAPACITOR CH 6.3V 1U	1	
	C1501	F1J1A106A043	C.CAPACITOR CH 10V 10U	1	
	C1502	F1H1A4750004	C.CAPACITOR CH 10V 4.7U	1	
	C1503	F1H1A4750004	C.CAPACITOR CH 10V 4.7U	1	
	C1504	ECJ1VB1A105K	C.CAPACITOR CH 10V 1U	1	
	C1505	FIG1H1020008	C.CAPACITOR CH 50V 1000P	1	
	C1506	FIG0J1050007	C.CAPACITOR CH 6.3V 1U	1	
	C1507	FIG0J1050007	C.CAPACITOR CH 6.3V 1U	1	
	C2001	FIG1A104A012	C.CAPACITOR CH 10V 0.1U	1	
	C4001	ECJ1VB1A105K	C.CAPACITOR CH 10V 1U	1	
	C4002	FIG0J1050007	C.CAPACITOR CH 6.3V 1U	1	
	C4003	FIG0J1050007	C.CAPACITOR CH 6.3V 1U	1	
	C4004	FIG0J1050007	C.CAPACITOR CH 6.3V 1U	1	
	C4005	F1H1E105A144	C.CAPACITOR CH 25V 1U	1	
	C4006	ECJ1VB1A105K	C.CAPACITOR CH 10V 1U	1	
	C4007	ECJ1VB1A105K	C.CAPACITOR CH 10V 1U	1	
	C4008	F1H1C105A097	C.CAPACITOR CH 16V 1U	1	
	C4009	F1H0J2250008	C.CAPACITOR CH 6.3V 2.2U	1	
	C4010	F1H1A225A025	C.CAPACITOR CH 10V 2.2U	1	
	C4011	F1H0J2250008	C.CAPACITOR CH 6.3V 2.2U	1	
	C4012	F1H0J2250008	C.CAPACITOR CH 6.3V 2.2U	1	
	C4013	F1H0J2250008	C.CAPACITOR CH 6.3V 2.2U	1	
	C4014	ECJ1VB1A105K	C.CAPACITOR CH 10V 1U	1	
	C4015	ECJ1VB1A105K	C.CAPACITOR CH 10V 1U	1	
	C5002	FIG1A104A012	C.CAPACITOR CH 10V 0.1U	1	
	C5003	FIG1A104A012	C.CAPACITOR CH 10V 0.1U	1	
	C5005	FIG0J1050007	C.CAPACITOR CH 6.3V 1U	1	
	C5006	FIG0J1050007	C.CAPACITOR CH 6.3V 1U	1	
	C5007	FIG0J1050007	C.CAPACITOR CH 6.3V 1U	1	
	C5009	F1H0J4750005	C.CAPACITOR CH 6.3V 4.7U	1	
	C5010	FIG1A104A012	C.CAPACITOR CH 10V 0.1U	1	
	C5012	FIG0J1050007	C.CAPACITOR CH 6.3V 1U	1	
	C5013	FIG0J1050007	C.CAPACITOR CH 6.3V 1U	1	
	C5016	ECJ0EB1A473K	C.CAPACITOR CH 10V 0.047U	1	
	C5017	ECJ0EB1A473K	C.CAPACITOR CH 10V 0.047U	1	
	C5020	ECJ0EC1H470J	C.CAPACITOR CH 50V 47P	1	
	C5021	ECJ0EC1H470J	C.CAPACITOR CH 50V 47P	1	
	C6001	FIG0J1050007	C.CAPACITOR CH 6.3V 1U	1	
	C6002	F1J1A106A043	C.CAPACITOR CH 10V 10U	1	
	C6003	FIG1A104A012	C.CAPACITOR CH 10V 0.1U	1	
	C6004	FIG1A104A012	C.CAPACITOR CH 10V 0.1U	1	
	C6005	FIG1A104A012	C.CAPACITOR CH 10V 0.1U	1	
	C6006	FIG1C1030008	C.CAPACITOR CH 16V 0.01U	1	

Model No. : DMC-TZ27/TZ30/TZ31/ZS19/ZS20 Parts List

Safety	Ref. No.	Part No.	Part Name & Description	Q'ty	Remarks
	C6007	FIG1C1030008	C.CAPACITOR CH 16V 0.01U	1	
	C6010	FIG1A104A012	C.CAPACITOR CH 10V 0.1U	1	
	C6021	FIG1A104A012	C.CAPACITOR CH 10V 0.1U	1	(TZ30/ZS20/19) EE,GC,GA,SG,GN,P, PC,PU,GH,GT,GK
	C6022	FIG1H0106A009	C.CAPACITOR CH 6.3V 10U	1	
	C6023	FIG1A104A012	C.CAPACITOR CH 10V 0.1U	1	(TZ30/31/27) EG,EP,EF,EB,EC
	C6024	FIG1A104A012	C.CAPACITOR CH 10V 0.1U	1	
	C6025	FIG1H0106A009	C.CAPACITOR CH 6.3V 10U	1	
	C6026	FIG1C1030008	C.CAPACITOR CH 16V 0.01U	1	
	C6027	FIG1A106A043	C.CAPACITOR CH 10V 10U	1	
	C6028	FIG1H0106A009	C.CAPACITOR CH 6.3V 10U	1	
	C6029	FIG1C1030008	C.CAPACITOR CH 16V 0.01U	1	
	C6030	FIG1A104A012	C.CAPACITOR CH 10V 0.1U	1	
	C6034	FIG1A104A012	C.CAPACITOR CH 10V 0.1U	1	
	C6035	FIG1C1030008	C.CAPACITOR CH 16V 0.01U	1	
	C6036	FIG1A104A012	C.CAPACITOR CH 10V 0.1U	1	
	C6037	FIG1A104A012	C.CAPACITOR CH 10V 0.1U	1	
	C6038	FIG1C1030008	C.CAPACITOR CH 16V 0.01U	1	
	C6041	FIG1A104A012	C.CAPACITOR CH 10V 0.1U	1	
	C6043	FIG1A104A012	C.CAPACITOR CH 10V 0.1U	1	
	C6051	ECJ1VB1A105K	C.CAPACITOR CH 10V 1U	1	
	C6052	FIG1A104A012	C.CAPACITOR CH 10V 0.1U	1	
	C6053	FIG1C1030008	C.CAPACITOR CH 16V 0.01U	1	
	C6054	ECJ0EC1H060D	C.CAPACITOR CH 50V 6P	1	
	C6055	ECJ0EC1H060D	C.CAPACITOR CH 50V 6P	1	
	C6056	FIG1H101A557	C.CAPACITOR CH 50V 100P	1	
	C6518	FIG1A104A012	C.CAPACITOR CH 10V 0.1U	1	(TZ30/31/ZS20) EG,EP,EF,EB,EE,GC,GA,SG,GN,P, PC,PU,GH,GT
	C6519	FIG1H0106A009	C.CAPACITOR CH 6.3V 4.7U	1	(TZ30/31/ZS20) EG,EP,EF,EB,EE,GC,GA,SG,GN,P, PC,PU,GH,GT
	C6520	FIG1H1020008	C.CAPACITOR CH 50V 1000P	1	(TZ30/31/ZS20) EG,EP,EF,EB,EE,GC,GA,SG,GN,P, PC,PU,GH,GT
	C6521	FIG1H0106A009	C.CAPACITOR CH 6.3V 10U	1	(TZ30/31/ZS20) EG,EP,EF,EB,EE,GC,GA,SG,GN,P, PC,PU,GH,GT
	C6522	FIG1A104A012	C.CAPACITOR CH 10V 0.1U	1	(TZ30/31/ZS20) EG,EP,EF,EB,EE,GC,GA,SG,GN,P, PC,PU,GH,GT
	C6523	FIG1A104A012	C.CAPACITOR CH 10V 0.1U	1	(TZ30/31/ZS20) EG,EP,EF,EB,EE,GC,GA,SG,GN,P, PC,PU,GH,GT
	C7001	FIG0J1050007	C.CAPACITOR CH 6.3V 1U	1	
	C7003	FIG0J1050007	C.CAPACITOR CH 6.3V 1U	1	
	C7006	FIG1C1030008	C.CAPACITOR CH 16V 0.01U	1	
	C7007	FIG1C1030008	C.CAPACITOR CH 16V 0.01U	1	
	C7008	FIG1C1030008	C.CAPACITOR CH 16V 0.01U	1	
	C7009	FIG1C1030008	C.CAPACITOR CH 16V 0.01U	1	
	C7010	FIG0J1050007	C.CAPACITOR CH 6.3V 1U	1	
	C7011	FIG0J1050007	C.CAPACITOR CH 6.3V 1U	1	
	C7014	ECJ1VB1A105K	C.CAPACITOR CH 10V 1U	1	
	C7019	FIG1A106A043	C.CAPACITOR CH 10V 10U	1	
	C7101	FIG1H0106A009	C.CAPACITOR CH 6.3V 10U	1	
	C7102	FIG1A104A012	C.CAPACITOR CH 10V 0.1U	1	
	C7104	FIG1A104A012	C.CAPACITOR CH 10V 0.1U	1	
	C7105	FIG1A104A012	C.CAPACITOR CH 10V 0.1U	1	
	C7106	FIG1A104A012	C.CAPACITOR CH 10V 0.1U	1	
	C8001	FIG0J1050007	C.CAPACITOR CH 6.3V 1U	1	[PAVCX]
	C8006	FIG1H0106A018	C.CAPACITOR 250V 0.047U	1	[PAVCX]
	C8008	FIG1H101A565	C.CAPACITOR CH 50V 100P	1	[PAVCX]
	C8009	FIG0J106A018	C.CAPACITOR CH 6.3V 10U	1	[PAVCX]
	C9001	ECJ0EC1H100D	C.CAPACITOR CH 50V 10P	1	
	C9002	ECJ0EC1H150J	C.CAPACITOR CH 50V 15P	1	
	C9003	FIG1A106A043	C.CAPACITOR CH 10V 10U	1	
	C9012	ECJ0EC1H100D	C.CAPACITOR CH 50V 10P	1	
	C9013	ECJ0EC1H100D	C.CAPACITOR CH 50V 10P	1	

Model No. : DMC-TZ27/TZ30/TZ31/ZS19/ZS20 Parts List

Safety	Ref. No.	Part No.	Part Name & Description	Q'ty	Remarks
	C9014	ECJ0EC1H100D	C.CAPACITOR CH 50V 10P	1	
	C9015	ECJ0EC1H100D	C.CAPACITOR CH 50V 10P	1	
	C9020	FIG1A104A012	C.CAPACITOR CH 10V 0.1U	1	
	C9021	FIG1A104A012	C.CAPACITOR CH 10V 0.1U	1	
	C9022	FIG1A104A012	C.CAPACITOR CH 10V 0.1U	1	
	C9101	FIG1H1020008	C.CAPACITOR CH 50V 1000P	1	
	C9102	FIG0J1050007	C.CAPACITOR CH 6.3V 1U	1	
	C9103	FIG1H120A557	C.CAPACITOR CH 50V 12P	1	
	C9104	ECJ0EC1H100D	C.CAPACITOR CH 50V 10P	1	
	C9105	FIG0J1050007	C.CAPACITOR CH 6.3V 1U	1	
	C9106	FIG0J1050007	C.CAPACITOR CH 6.3V 1U	1	
	C9107	FIG0J1050007	C.CAPACITOR CH 6.3V 1U	1	
	C9108	FIG1A104A012	C.CAPACITOR CH 10V 0.1U	1	
	C9109	FIG1A106A043	C.CAPACITOR CH 10V 10U	1	
	C9110	FIG1A104A012	C.CAPACITOR CH 10V 0.1U	1	
	C9111	FIG0J1050007	C.CAPACITOR CH 6.3V 1U	1	
	C9301	ECJ0EB1A473K	C.CAPACITOR CH 10V 0.047U	1	
	C9302	ECJ0EB1A473K	C.CAPACITOR CH 10V 0.047U	1	
	C9303	FIG1H1020008	C.CAPACITOR CH 50V 1000P	1	
	C9304	FIG1H1020008	C.CAPACITOR CH 50V 1000P	1	
	CX6001	F5A84103A020	CAPACITOR NETWORKS	1	
	CX6002	F5A84103A020	CAPACITOR NETWORKS	1	
	D1060	B0JCF0000004	DIODE	1	E.S.D.
	D1501	B0JCF0000004	DIODE	1	E.S.D.
	D2001	DB2S31100L	DIODE	1	E.S.D.
	D6001	DA2S10100L	DIODE	1	E.S.D.
	D6501	B0ADDH000014	DIODE	1	(TZ30/31/ZS20) EG,EP,EF,EB,EE,GC,GA,SG,G N,P, PC,PU,GH,GT E.S.D.
	D6502	B3ABB0000210	LED	1	(TZ30/31/ZS20) EG,EP,EF,EB,EE,GC,GA,SG,G N,P, PC,PU,GH,GT E.S.D.
	D8002	B0ECFR0000003	DIODE	1	E.S.D. [PAVCX]
	D9011	B0BC5R6A0169	DIODE	1	E.S.D.
	D9012	B0BC5R6A0169	DIODE	1	E.S.D.
	D9013	B0BC5R6A0169	DIODE	1	E.S.D.
	D9014	B0BC5R6A0169	DIODE	1	E.S.D.
	D9101	DB3S406F0L	DIODE	1	E.S.D.
	D9103	B0ADDH000014	DIODE	1	E.S.D.
	D9201	B3AAB0000343	LED	1	E.S.D.
	D9901	B3ADB0000142	LED	1	E.S.D.
	ET2001	K4ZZ01000208	EARTH TERMINAL	1	
	ET9901	K4AC01D00001	EARTH SPRING	1	
	ET9902	K4AC01D00001	EARTH SPRING	1	
	ET9903	N9ZZ00000333	EARTH SPRING	1	
	F2001	K5H1522A0018	FUSE 32V 1.5A	1	
	F2002	K5H202Y00007	FUSE 32V 2.0A	1	
	F8001	ERBRE1R25V	FUSE 32V 1.25A	1	[PAVCX]
	F8002	K5H202Y00007	FUSE 32V 2.0A	1	[PAVCX]
	FL2001	EXC28CH900U	FILTER	1	
	FL2002	EXC28CH900U	FILTER	1	
	FL2003	F1H0J105A037	C.CAPACITOR CH 6.3V 1U	1	
	FP9001	K1MY51BA0235	CONNECTOR 51P	1	
	FP9005	K1MY45BA0235	CONNECTOR 45P	1	
	FP9202	K1MY51BA0235	CONNECTOR 51P	1	
	FP9203	K1MY04BA0370	CONNECTOR 4P	1	
	FP9902	K1MY04BA0370	CONNECTOR 4P	1	
	IC1001	C1ZBZ0004588	IC	1	E.S.D.
	IC1010	C0DBGYY00821	IC	1	E.S.D.
	IC1020	C0DBGYY02557	IC	1	E.S.D.
	IC1021	C0DBGYY02527	IC	1	E.S.D.
	IC1030	C0DBAYY01141	IC	1	E.S.D.
	IC1040	C0DBGYY02497	IC	1	E.S.D.
	IC1041	C0DBGYY00779	IC	1	E.S.D.

Model No. : DMC-TZ27/TZ30/TZ31/ZS19/ZS20 Parts List

Safety	Ref. No.	Part No.	Part Name & Description	Q'ty	Remarks
	IC1501	CLZBZ0004582	IC	1	E.S.D.
	IC1502	CLCB00003709	IC	1	E.S.D.
	IC6001	VSG1012	IC	1	(TZ30/31) EG,EP,EF,EB E.S.D.
	IC6001	VSG1011	IC	1	(TZ30/ZS20) EE,GC,GA,SG,GN,P,PC,PU,GH,GT, GK, TZ27, ZS19 E.S.D.
	IC6005	RS10316	IC	1	(TZ30/31/ZS20) EG,EP,EF,EB,EE,GC,GA,SG,GN,P, PC,PU,GH,GT E.S.D.
	IC6005	RS10317	IC	1	GK, TZ27, ZS19 E.S.D.
	IC6502	C0JBAU000097	IC	1	(TZ30/31/ZS20) EG,EP,EF,EB,EE,GC,GA,SG,GN,P, PC,PU,GH,GT E.S.D.
	IC6503	C0DBAYY00955	IC	1	(TZ30/31/ZS20) EG,EP,EF,EB,EE,GC,GA,SG,GN,P, PC,PU,GH,GT E.S.D.
	IC6504	C0DBGYY00672	IC	1	(TZ30/31/ZS20) EG,EP,EF,EB,EE,GC,GA,SG,GN,P, PC,PU,GH,GT E.S.D.
	IC7101	EWT99PSX1A	IC	1	E.S.D.
	IC8101	C0ZBZ0001938	IC	1	E.S.D. [PAVCX]
	IC9101	CLAB00003449	IC	1	E.S.D.
	JK2001	K1FB108E0008	JACK	1	
	JK2002	K1FY119E0056	JACK	1	
	L1010	G1C2R2MA0428	CHIP INDUCTOR 2.2UH	1	
	L1020	G1C3R3MA0392	CHIP INDUCTOR 3.3UH	1	
	L1030	G1C4R7MA0328	CHIP INDUCTOR 4.7UH	1	
	L1031	G1C4R7MA0328	CHIP INDUCTOR 4.7UH	1	
	L1040	G1C2R2MA0392	CHIP INDUCTOR 2.2UH	1	
	L1050	G1C2R2MA0392	CHIP INDUCTOR 2.2UH	1	
	L1060	G1C100MA0428	CHIP INDUCTOR 10UH	1	
	L1501	G1C4R7MA0328	CHIP INDUCTOR 4.7UH	1	
	L2001	J0ZZB0000142	FILTER	1	
	L6504	G1C4R7MA0172	CHIP INDUCTOR 4.7UH	1	(TZ30/31/ZS20) EG,EP,EF,EB,EE,GC,GA,SG,GN,P, PC,PU,GH,GT
	LB2001	J0JCC0000415	FILTER	1	
	LB2002	J0JCC0000415	FILTER	1	
	LB2003	J0JCC0000415	FILTER	1	
	LB2004	J0JCC0000415	FILTER	1	
	LB2005	J0JYC0000061	FILTER	1	
	LB2006	J0JYC0000061	FILTER	1	
	LB2007	J0JYC0000061	FILTER	1	
	LB2008	J0JYC0000061	FILTER	1	
	LB6002	J0JYC0000086	FILTER	1	
	LB6004	J0JCC0000317	FILTER	1	
	P8002	K4ZZ04000051	CONNECTOR 4P	1	[PAVCX]
	P9007	K1NA09E00151	CONNECTOR 9P	1	
	PP8001	K1KA20A00306	CONNECTOR 20P	1	[PAVCX]
	PP9006	K1KY40AA0343	CONNECTOR 40P	1	
	PP9901	K1KA34BA0342	CONNECTOR 34P	1	
	PS9201	K1KB40AA0021	CONNECTOR 40P	1	
	PS9903	K1KA20A00275	CONNECTOR 20P	1	
	PS9904	K1KB34AA0123	CONNECTOR 34P	1	
	Q1501	FG6943010R	TRANSISTOR	1	E.S.D.
	Q8001	BJJBLP000038	TRANSISTOR	1	E.S.D. [PAVCX]
	QR1501	DRC3114E0L	TRANSISTOR-RESISTOR	1	E.S.D.
	QR6001	DRC3144W0L	TRANSISTOR-RESISTOR	1	E.S.D.
	QR9301	DMG964040R	TRANSISTOR-RESISTOR	1	E.S.D.
	QR9302	DMG964040R	TRANSISTOR-RESISTOR	1	E.S.D.
	R1006	ERJ2RKD120	M.RESISTOR CH 1/16W 12	1	
	R1031	ERJ2RHD433	M.RESISTOR CH 1/16W 43K	1	
	R1032	ERJ2RHD823	M.RESISTOR CH 1/16W 82K	1	
	R1051	ERJ2RHD753	M.RESISTOR CH 1/16W 75K	1	
	R1052	ERJ2RKD154	M.RESISTOR CH 1/16W 150K	1	
	R1501	ERJ2RHD103	M.RESISTOR CH 1/16W 10K	1	
	R1502	ERJ2GEJ104	M.RESISTOR CH 1/10W 100K	1	
	R1503	ERJ2GEJ104	M.RESISTOR CH 1/10W 100K	1	

Model No. : DMC-TZ27/TZ30/TZ31/ZS19/ZS20 Parts List

Safety	Ref. No.	Part No.	Part Name & Description	Q'ty	Remarks
	R1507	ERJ2GEJ104	M.RESISTOR CH 1/10W 100K	1	
	R1508	ERJ2GEJ472	M.RESISTOR CH 1/10W 4.7K	1	
	R2001	ERJ2GEJ750	M.RESISTOR CH 1/10W 75	1	
	R2002	ERJ2GEJ561	M.RESISTOR CH 1/16W 560	1	
	R2005	ERJ2GEJ102X	M.RESISTOR CH 1/16W 1K	1	
	R2009	ERJ2GED273X	M.RESISTOR CH 1/10W 27K	1	
	R2010	ERJ2GEJ202	M.RESISTOR CH 1/10W 2K	1	
	R2011	ERJ2GEJ202	M.RESISTOR CH 1/10W 2K	1	
	R2012	ERJ2RHD682X	M.RESISTOR CH 1/10W 6.8K	1	
	R4001	ERJ2GEJ224	M.RESISTOR CH 1/10W 220K	1	
	R5011	ERJ2GEJ222	M.RESISTOR CH 1/10W 2.2K	1	
	R5013	ERJ2GEJ222	M.RESISTOR CH 1/10W 2.2K	1	
	R5016	ERJ2GEJ333	M.RESISTOR CH 1/16W 33K	1	
	R5017	ERJ2GEJ333	M.RESISTOR CH 1/16W 33K	1	
	R6001	ERJ2RKF1183	M.RESISTOR CH 1/16W 118K	1	
	R6002	ERJ2RHD222	M.RESISTOR CH 1/16W 2.2K	1	
	R6004	ERJ2RHD122	M.RESISTOR CH 1/16W 1.2K	1	
	R6005	ERJ2RHD561	M.RESISTOR CH 1/16W 560	1	
	R6008	DOYAR0000007	M.RESISTOR CH 1/10W 0	1	(TZ30/31) EG,EP,EF,EB
	R6009	ERJ2GEJ102X	M.RESISTOR CH 1/16W 1K	1	
	R6011	DOYAR0000007	M.RESISTOR CH 1/10W 0	1	
	R6012	ERJ2RHD511	M.RESISTOR CH 1/16W 510	1	
	R6021	ERJ2GEJ103	M.RESISTOR CH 1/10W 10K	1	
	R6022	ERJ2RKF6201	M.RESISTOR CH 1/16W 6.2K	1	
	R6028	ERJ2RHD511	M.RESISTOR CH 1/16W 510	1	
	R6030	ERJ2RHD511	M.RESISTOR CH 1/16W 510	1	
	R6032	ERJ2RHD511	M.RESISTOR CH 1/16W 510	1	
	R6034	ERJ2RHD511	M.RESISTOR CH 1/16W 510	1	
	R6036	ERJ2RHD511	M.RESISTOR CH 1/16W 510	1	
	R6038	ERJ2RHD511	M.RESISTOR CH 1/16W 510	1	
	R6040	ERJ2RHD241	M.RESISTOR CH 1/16W 240	1	
	R6042	ERJ2RKF2800	M.RESISTOR CH 1/16W 28	1	
	R6043	ERJ2GEJ103	M.RESISTOR CH 1/10W 10K	1	
	R6047	DOYAR0000007	M.RESISTOR CH 1/10W 0	1	(TZ30/31) EG,EP,EF,EB, TZ27
	R6048	ERJ2GEJ472	M.RESISTOR CH 1/10W 4.7K	1	
	R6049	ERJ2GEJ472	M.RESISTOR CH 1/10W 4.7K	1	
	R6052	ERJ2GEJ101	M.RESISTOR CH 1/10W 100	1	
	R6053	ERJ2GEJ473	M.RESISTOR CH 1/16W 47K	1	
	R6054	ERJ2GEJ101	M.RESISTOR CH 1/10W 100	1	
	R6056	ERJ2RKD330	M.RESISTOR CH 1/16W 33	1	
	R6058	ERJ2GEJ105	M.RESISTOR CH 1/10W 1M	1	
	R6059	ERJ2GEJ101	M.RESISTOR CH 1/10W 100	1	
	R6502	ERJ2GEJ561	M.RESISTOR CH 1/16W 560	1	(TZ30/31/ZS20) EG,EP,EF,EB,EE,GC,GA,SG,G N,P, PC,PU,GH,GT
	R6508	ERJ2GEJ105	M.RESISTOR CH 1/10W 1M	1	(TZ30/31/ZS20) EG,EP,EF,EB,EE,GC,GA,SG,G N,P, PC,PU,GH,GT
	R6509	ERJ2GEJ225	M.RESISTOR CH 1/16W 2.2M	1	(TZ30/31/ZS20) EG,EP,EF,EB,EE,GC,GA,SG,G N,P, PC,PU,GH,GT
	R7002	ERJ2RKD680	M.RESISTOR CH 1/16W 68	1	
	R7007	ERJ2RKD680	M.RESISTOR CH 1/16W 68	1	
	R7009	D1BA1R00A079	M.RESISTOR CH 1/8W 1	1	
	R7021	ERJ2RHD822X	M.RESISTOR CH 1/16W 8.2K	1	
	R8001	ERJ6GEY0R00V	M.RESISTOR CH 1/8W 0	1	[PAVCX]
	R8002	D0GB104JA065	M.RESISTOR CH 1/10W 100K	1	[PAVCX]
	R8003	D0GB820JA065	M.RESISTOR CH 1/10W 82	1	[PAVCX]
	R8005	ERJ6GEYJ514V	M.RESISTOR CH 1/8W 510K	1	[PAVCX]
	R8006	ERJ6GEYJ514V	M.RESISTOR CH 1/8W 510K	1	[PAVCX]
	R8013	ERJ2RHD1621X	M.RESISTOR CH 1/16W 1620	1	[PAVCX]
	R8021	D0GA303JA023	M.RESISTOR CH 1/16W 30K	1	[PAVCX]
	R8032	D1BD4703A119	CHIP RESISTOR	1	[PAVCX]
	R9001	ERJ2GEJ102X	M.RESISTOR CH 1/16W 1K	1	
	R9002	ERJ2GEJ102X	M.RESISTOR CH 1/16W 1K	1	

Model No. : DMC-TZ27/TZ30/TZ31/ZS19/ZS20 Parts List

Safety	Ref. No.	Part No.	Part Name & Description	Q'ty	Remarks
	R9020	ERJ2GEJ151	M.RESISTOR CH 1/10W 150	1	
	R9021	ERJ2GEJ151	M.RESISTOR CH 1/10W 150	1	
	R9022	ERJ2GEJ183	M.RESISTOR CH 1/10W 18K	1	
	R9023	ERJ2GEJ183	M.RESISTOR CH 1/10W 18K	1	
	R9025	ERJ2GED273X	M.RESISTOR CH 1/10W 27K	1	
	R9026	ERJ2GEJ221	M.RESISTOR CH 1/16W 220	1	
	R9032	ERJ2GEJ223	M.RESISTOR CH 1/16W 22K	1	
	R9041	ERJ2RKF1000	M.RESISTOR CH 1/16W 1K	1	
	R9042	ERJ2RKF1000	M.RESISTOR CH 1/16W 1K	1	
	R9043	ERJ2RKF1000	M.RESISTOR CH 1/16W 1K	1	
	R9044	ERJ2RKF1000	M.RESISTOR CH 1/16W 1K	1	
	R9047	ERJ2RKF1000	M.RESISTOR CH 1/16W 1K	1	
	R9048	ERJ2RKF1000	M.RESISTOR CH 1/16W 1K	1	
	R9049	ERJ2RKF1000	M.RESISTOR CH 1/16W 1K	1	
	R9050	ERJ2RKF1000	M.RESISTOR CH 1/16W 1K	1	
	R9101	ERJ2RHD183	M.RESISTOR CH 1/16W 18K	1	
	R9102	ERJ2RHD223	M.RESISTOR CH 1/16W 22K	1	
	R9105	ERJ2GEJ331	M.RESISTOR CH 1/16W 330	1	
	R9106	ERJ2GEJ824	M.RESISTOR CH 1/16W 820K	1	
	R9107	ERJ2GEJ334	M.RESISTOR CH 1/16W 330K	1	
	R9201	ERJ2GEJ242	M.RESISTOR CH 1/16W 2.4K	1	
	R9202	ERJ2GEJ392	M.RESISTOR CH 1/10W 3.9K	1	
	R9203	ERJ2GEJ752X	M.RESISTOR CH 1/10W 7.5K	1	
	R9204	ERJ2GEJ242	M.RESISTOR CH 1/16W 2.4K	1	
	R9205	ERJ2GEJ392	M.RESISTOR CH 1/10W 3.9K	1	
	R9206	ERJ2GEJ752X	M.RESISTOR CH 1/10W 7.5K	1	
	R9207	ERJ2GEJ182	M.RESISTOR CH 1/10W 1.8K	1	
	R9301	ERJ2GEJ104	M.RESISTOR CH 1/10W 100K	1	
	R9302	ERJ2GEJ104	M.RESISTOR CH 1/10W 100K	1	
	R9303	ERJ2GEJ104	M.RESISTOR CH 1/10W 100K	1	
	R9304	ERJ2GEJ104	M.RESISTOR CH 1/10W 100K	1	
	R9901	ERJ2GEJ112	M.RESISTOR CH 1/16W 1.1K	1	
	R9902	ERJ2GEJ152	M.RESISTOR CH 1/16W 1.5K	1	
	R9903	ERJ2GEJ182	M.RESISTOR CH 1/10W 1.8K	1	
	R9904	ERJ2GEJ242	M.RESISTOR CH 1/16W 2.4K	1	
	R9905	ERJ2GEJ332	M.RESISTOR CH 1/16W 3.3K	1	
	R9906	ERJ2GEJ512X	M.RESISTOR CH 1/16W 5.1K	1	
	R9907	ERJ2GEJ822	M.RESISTOR CH 1/10W 8.2K	1	
	R9908	ERJ2GEJ163X	M.RESISTOR CH 1/16W 16K	1	
	R9909	ERJ2GEJ473	M.RESISTOR CH 1/16W 47K	1	
	R9910	ERJ2GEJ242	M.RESISTOR CH 1/16W 2.4K	1	
	R9911	ERJ2GEJ392	M.RESISTOR CH 1/10W 3.9K	1	
	R9912	ERJ2GEJ752X	M.RESISTOR CH 1/10W 7.5K	1	
	R9913	DOYAR0000007	M.RESISTOR CH 1/10W 0	1	
	R9914	DOYAR0000007	M.RESISTOR CH 1/10W 0	1	
	R9916	ERJ2GEJ203X	M.RESISTOR CH 1/16W 22K	1	
	R9922	ERJ2GEJ512X	M.RESISTOR CH 1/16W 5.1K	1	
	R9928	ERJ3GEYJ100	M.RESISTOR CH 1/10W 10	1	
	R9929	ERJ3GEYJ100	M.RESISTOR CH 1/10W 10	1	
	R9951	ERJ2GEJ102X	M.RESISTOR CH 1/16W 1K	1	
	RX6001	EXB28V103JX	RESISTOR NETWORKS	1	
	RX6002	D1H410120001	RESISTOR	1	
	RX6003	D1H410320002	RESISTOR NETWORKS	1	
	RX6051	D1H82214A024	RESISTOR NETWORKS	1	
	RX6052	D1H82214A024	RESISTOR NETWORKS	1	
	RX6053	D1H82214A024	RESISTOR NETWORKS	1	
	RX6054	D1H82214A024	RESISTOR NETWORKS	1	
	RX9001	D1H84734A024	RESISTOR NETWORKS	1	
	RX9002	D1H86804A024	RESISTOR NETWORKS	1	
	RX9101	D1H81024A024	RESISTOR NETWORKS	1	
	S9001	K0D112B00145	SWITCH	1	
	S9201	K0F111A00541	SWITCH	1	

Model No. : DMC-TZ27/TZ30/TZ31/ZS19/ZS20 Parts List

Safety	Ref. No.	Part No.	Part Name & Description	Q'ty	Remarks
	S9202	K0F111A00541	SWITCH	1	
	S9203	K0F111A00541	SWITCH	1	
	S9204	K0F111A00541	SWITCH	1	
	S9206	K0F111A00541	SWITCH	1	
	S9207	K0F111A00541	SWITCH	1	
	S9208	K0F111A00541	SWITCH	1	
	S9210	K0F111A00541	SWITCH	1	
	S9901	K0MZ26000005	SWITCH	1	
	S9902	K0D112B00145	SWITCH	1	
	S9903	K0F111A00583	SWITCH	1	
	S9904	K0G199A00012	SWITCH	1	
	T8001	G5DYA0000139	TRANSFORMER	1	[PAVCX]
	T8002	G5F1A0000026	CHIP INDUCTOR	1	[PAVCX]
	TH6001	D4CC11030013	THERMISTOR	1	
	VA9002	D4ED18R0A014	VARISTOR	1	
	VA9003	D4ED18R0A014	VARISTOR	1	
	VA9004	D4ED18R0A014	VARISTOR	1	
	VA9005	D4ED18R0A014	VARISTOR	1	
	VA9006	D4ED18R0A014	VARISTOR	1	
	VA9007	D4ED18R0A014	VARISTOR	1	
	VA9008	D4ED18R0A014	VARISTOR	1	
	VA9009	D4ED18R0A014	VARISTOR	1	
	VA9010	D4ED18R0A014	VARISTOR	1	
	VA9011	D4ED18R00008	VARISTOR	1	
	VA9012	D4ED18R00008	VARISTOR	1	
	VA9013	D4ED18R00008	VARISTOR	1	
	VA9014	D4ED18R00008	VARISTOR	1	
	VA9015	D4ED18R00008	VARISTOR	1	
	VA9016	D4ED18R00008	VARISTOR	1	
	VA9017	D4ED18R00008	VARISTOR	1	
	VA9018	D4ED18R00008	VARISTOR	1	
	VA9019	D4ED18R00008	VARISTOR	1	
	VA9020	D4ED18R00008	VARISTOR	1	
	X6001	H0J240500048	CRYSTAL OSCILLATOR	1	
	X9101	H0J327200226	CRYSTAL OSCILLATOR	1	
	ZA6501	EBMGSE21R5KA	ANTENNA	1	(TZ30/31/ZS20) EG,EP,EF,EB,EE,GC,GA,SG,GN,P,PC,PU,GH,GT
	ZB9901	K3ZZ00200042	BATTERY HOLDER	1	

Model No. : DMC-TZ27/TZ30/TZ31/ZS19/ZS20 Frame and Casing Section

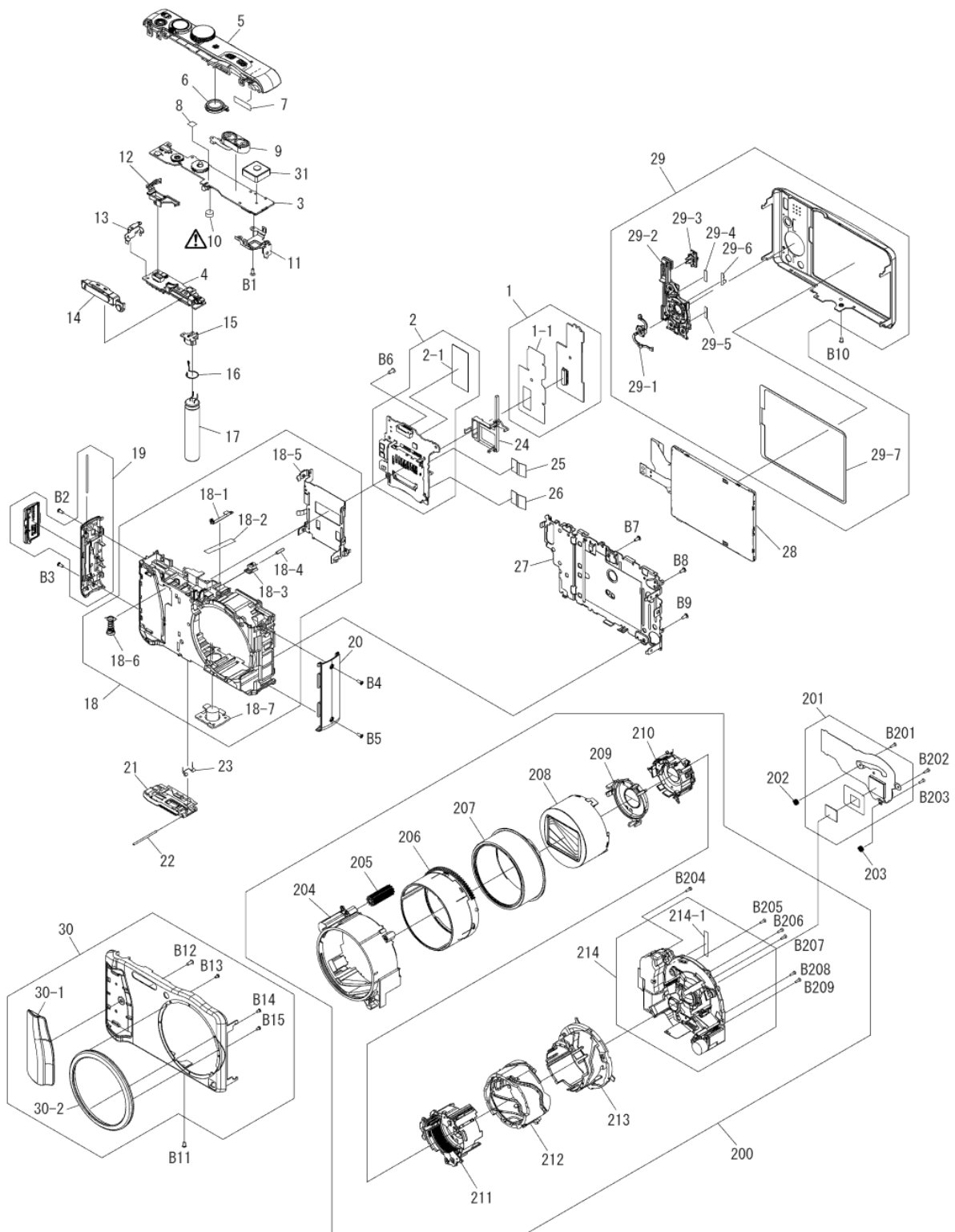

Model No. : DMC-TZ27/TZ30/TZ31/ZS19/ZS20 Packing Parts and Accessories Section (1)

(except for P/PC)

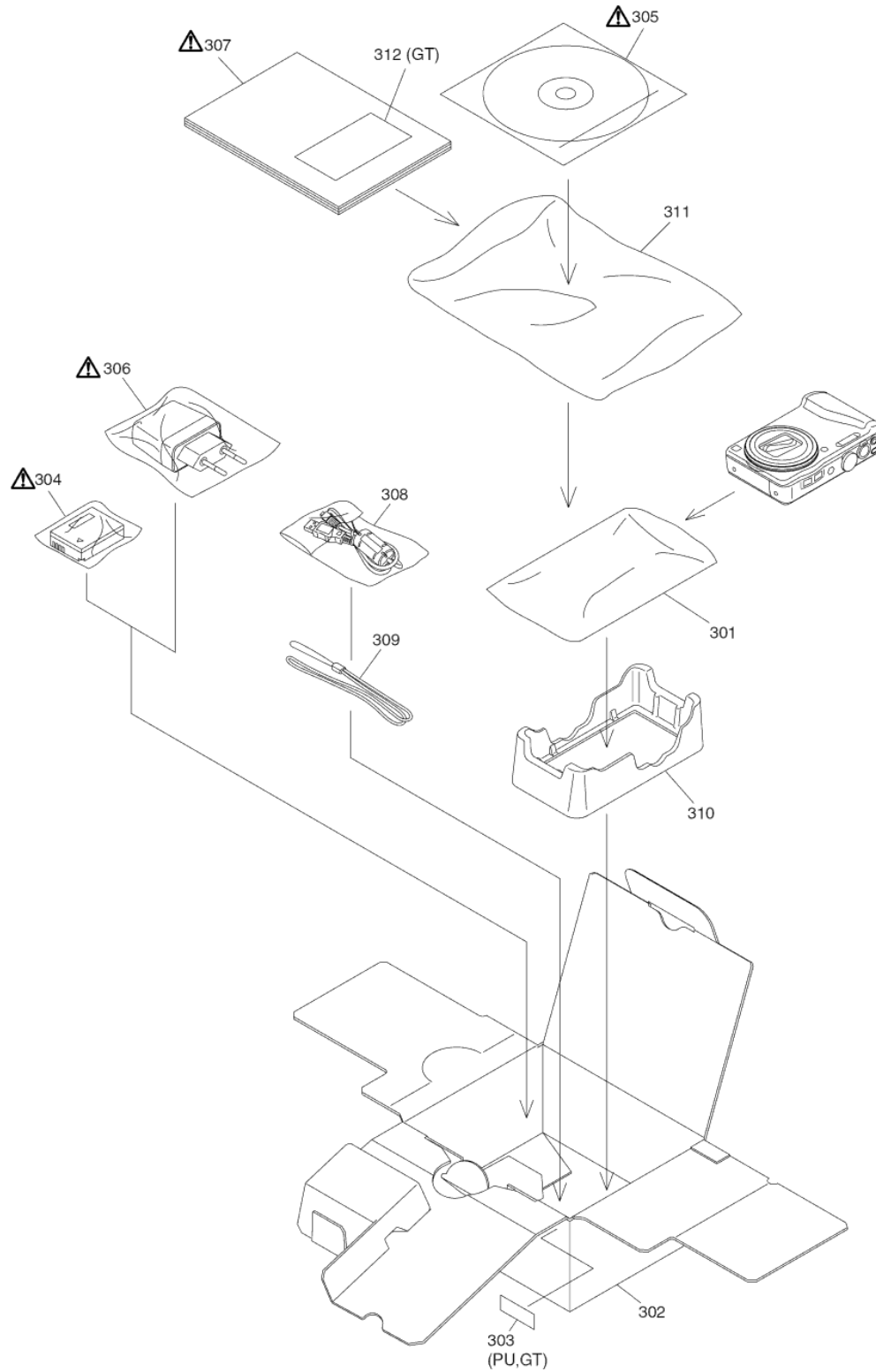

Model No. : DMC-TZ27/TZ30/TZ31/ZS19/ZS20 Packing Parts and Accessories Section (2)

(Only P,PC)

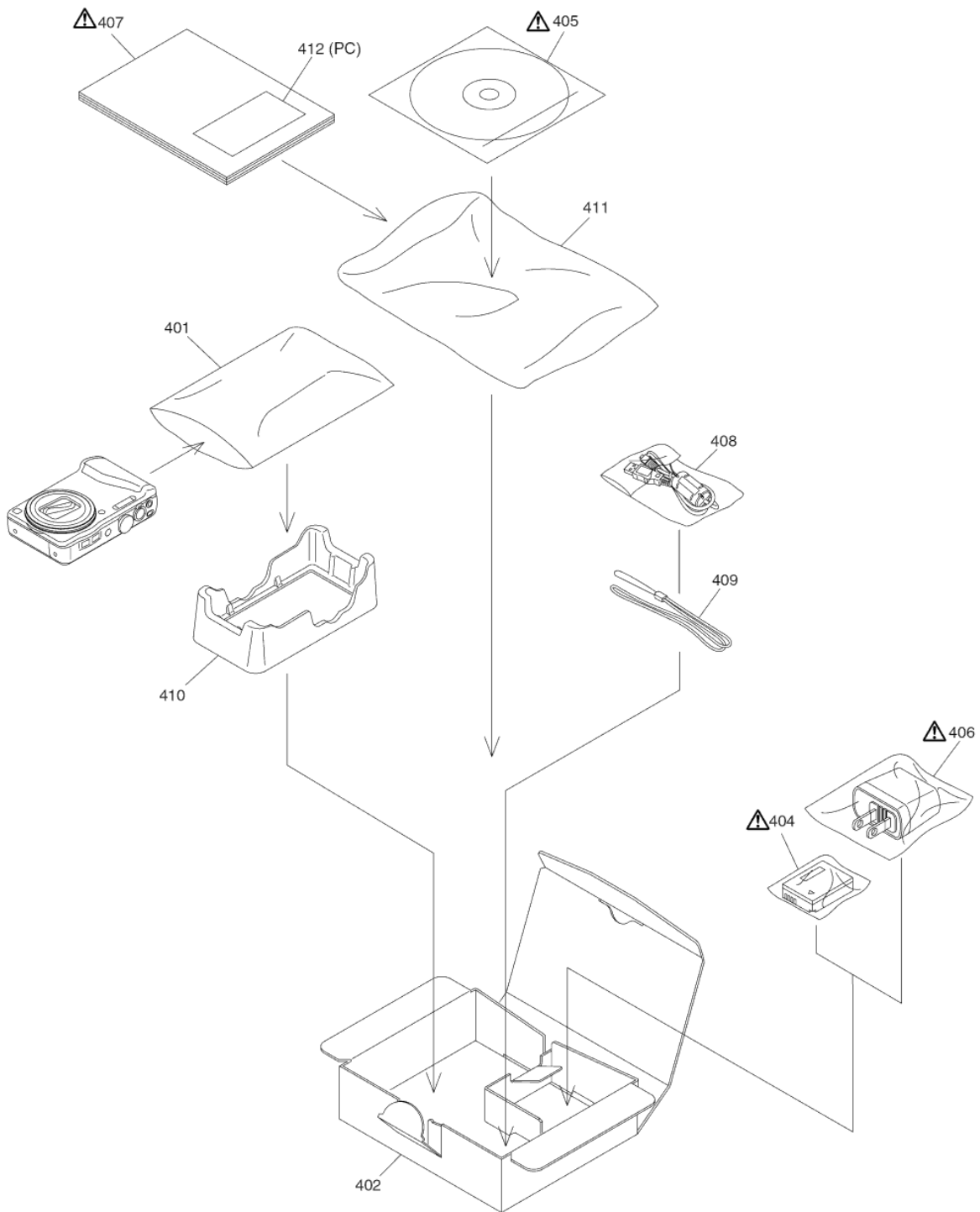



















Model No. : DMC-TZ27/TZ30/TZ31/ZS19/ZS20 Parts List

Safety	Ref. No.	Part No.	Part Name & Description	Q'ty	Remarks
	1	VEK0S84	OPERATION P.C.B. UNIT	1	(RTL)E.S.D.
	1-1	VGQ1B78	OPERATION SHEET	1	
	2	VEK0S88	MAIN P.C.B. UNIT	1	(RTL)E.S.D. (TZ30/31) EG,EP,EF,EB
	2	VEK0S87	MAIN P.C.B. UNIT	1	(RTL)E.S.D. (TZ30/ZS20) EE,GC,GA,SG,GN,P,PC,PU,GH,GT
	2	VEK0S89	MAIN P.C.B. UNIT	1	(RTL)E.S.D. TZ27
	2	VEK0S90	MAIN P.C.B. UNIT	1	(RTL)E.S.D. GK, ZS19
	2-1	VGQ1D50	DPR SHEET	1	
	3	VEP50116A	TOP P.C.B.	1	E.S.D. (TZ30/31/ZS20) EG,EP,EF,EB,EE,GC,GA,SG,GN,P,PC,PU,GH,GT
	3	VEP50116B	TOP P.C.B.	1	(RTL)E.S.D. GK, TZ27, ZS19
	4	VEP58178A	FLASH P.C.B.	1	(RTL) E.S.D. [PAVCX]
	5	VYK5K08	TOP CASE UNIT	1	(TZ30) (-K) EG,EP,EF,EB,EE,GC,GA,SG,GN (-T) EP,EF,EB,EE,GC,GA,GN
	5	VYK5K11	TOP CASE UNIT	1	(TZ30) (-S) EG,EP,EB,GC,GA, (-R) EG,EF,EB,EE,GC,GA,SG,GN (-W) EG,EP,EF,EB,GA,SG,GN
	5	VYK5Q57	TOP CASE UNIT	1	TZ31EG-K/-T
	5	VYK5R49	TOP CASE UNIT	1	TZ31EG-S/-R/-W
	5	VYK5Q58	TOP CASE UNIT	1	TZ27
	5	VYK5K09	TOP CASE UNIT	1	(ZS20) (-K) P,PC,PU,GH,GT (-T) GH,GT
	5	VYK5K12	TOP CASE UNIT	1	(ZS20) (-S) P,PC,PU,GH (-R) P,PC,PU (-W) P,GT
	5	VYK5K10	TOP CASE UNIT	1	GK-K/-T
	5	VYK5K13	TOP CASE UNIT	1	GK-S/-W
	5	VYK5T69	TOP CASE UNIT	1	ZS19
	6	L0AA01A00032	SPEAKER	1	
	7	VGQ1E55	DPR SHEET (GPS)	1	(TZ30/31/ZS20) EG,EP,EF,EB,EE,GC,GA,SG,GN,P,PC,PU,GH,GT
	8	VGQ1D29	TOP AF SHEET	1	
	9	L0CBAY000143	MICROPHONE UNIT	1	
	10	ML-421S/ZTK	BATTERY	1	(B9901) [ENERGY]
	11	VMP0C44	EARTH PLATE R	1	
	12	VGQ1B73	FLASH SPACER	1	
	13	VMP0C45	EARTH PLATE L	1	(ET8002) [PAVCX]
	14	VEK0S63	FLASH UNIT	1	[PAVCX]
	15	VGQ0S27	CONDENSER SPACER	1	[PAVCX]
	16	VMB4462	EARTH SPRING	1	(ET8001) [PAVCX]
	17	F2A2F9500008	CAPACITOR	1	(C8003) [PAVCX]
	18	VYK5V72	FRAME UNIT	1	[PAVCX]
	18-1	VMP0C64	GPS EARTH PLATE	1	[PAVCX]
	18-2	VGQ1B75	CURSOR BUTTON TAPE	1	[PAVCX]
	18-3	VGQ1B69	BATTERY LOCK KNOB	1	[PAVCX]
	18-4	VMB4587	BATTERY LOCK SPRING	1	[PAVCX]
	18-5	VMP0C43	BATTERY CASE	1	[PAVCX]
	18-6	VMB4538	BATTERY OUT SPRING	1	[PAVCX]
	18-7	VGQ1B70	TRIPOD	1	[PAVCX]
	19	VYK5K14	SIDE ORNAMENT L UNIT	1	(TZ30/31/ZS20) (-K/-T)
	19	VYK5K15	SIDE ORNAMENT L UNIT	1	(TZ30/31/ZS20) (-S/-R/-W), TZ27, ZS19
	20	VGK3878	SIDE ORNAMENT R	1	(TZ30/31/ZS20) (-K/-T)
	20	VGK3879	SIDE ORNAMENT R	1	(TZ30/31/ZS20) (-S/-R/-W), TZ27, ZS19
	21	VYK5Q09	BATTERY DOOR UNIT	1	(-K) [PAVCX]
	21	VYK5Q11	BATTERY DOOR UNIT	1	(-S) [PAVCX]
	21	VYK5Q12	BATTERY DOOR UNIT	1	(-T) [PAVCX]
	21	VYK5Q10	BATTERY DOOR UNIT	1	(-R) [PAVCX]
	21	VYK5Q13	BATTERY DOOR UNIT	1	(-W) [PAVCX]
	22	VMS7863	BATTERY DOOR SHAFT	1	[PAVCX]
	23	VMB4588	BATTERY DOOR SPRING	1	[PAVCX]
	24	VGQ1B74	PCB SPACER	1	
	25	VGQ0T64	FPC TAPE	1	
	26	VGQ0T64	FPC TAPE	1	
	27	VYK5V04	FRAME PLATE UNIT	1	















Model No. : DMC-TZ27/TZ30/TZ31/ZS19/ZS20 Parts List

Safety	Ref. No.	Part No.	Part Name & Description	Q'ty	Remarks
	28	L5EDDY00353	LCD UNIT	1	
	29	VYK5P97	REAR CASE UNIT	1	(-K) (EXCEPT ZS20GK-K, TZ27, ZS19) [PAVCX]
	29	VYK5P99	REAR CASE UNIT	1	(-S) (EXCEPT ZS20GK-S) [PAVCX]
	29	VYK5Q00	REAR CASE UNIT	1	(-T) (EXCEPT ZS20GK-T) [PAVCX]
	29	VYK5P98	REAR CASE UNIT	1	(-R) [PAVCX]
	29	VYK5Q01	REAR CASE UNIT	1	(-W) (EXCEPT ZS20GK-W) [PAVCX]
	29	VYK5Q02	REAR CASE UNIT	1	ZS20GK-K, TZ27, ZS19[PAVCX]
	29	VYK5Q04	REAR CASE UNIT	1	ZS20GK-S [PAVCX]
	29	VYK5Q05	REAR CASE UNIT	1	ZS20GK-T [PAVCX]
	29	VYK5Q06	REAR CASE UNIT	1	ZS20GK-W [PAVCX]
	29-1	VGU0L62	MENU BUTTON	1	[PAVCX]
	29-2	VGU0L61	CURSOR BUTTON	1	[PAVCX]
	29-3	VGU0L65	SLIDE KNOB	1	[PAVCX]
	29-4	VGQ1B75	CURSOR BUTTON TAPE	1	[PAVCX]
	29-5	VGQ1B75	CURSOR BUTTON TAPE	1	[PAVCX]
	29-6	VGL1420	REAR PANEL LED	1	[PAVCX]
	29-7	VGQ1B76	PROTECTION SHEET	1	[PAVCX]
	30	VYK5P86	FRONT CASE UNIT	1	(-K) (EXCEPT TZ27, ZS20P-K, ZS19) [PAVCX]
	30	VYK5P88	FRONT CASE UNIT	1	(-S) (EXCEPT ZS20P-S) [PAVCX]
	30	VYK5P89	FRONT CASE UNIT	1	(-T) [PAVCX]
	30	VYK5P87	FRONT CASE UNIT	1	(-R) (EXCEPT ZS20P-R) [PAVCX]
	30	VYK5P90	FRONT CASE UNIT	1	(-W) (EXCEPT ZS20P-W) [PAVCX]
	30	VYK5P96	FRONT CASE UNIT	1	TZ27 [PAVCX]
	30	VYK5P91	FRONT CASE UNIT	1	ZS20P-K [PAVCX]
	30	VYK5P93	FRONT CASE UNIT	1	ZS20P-S [PAVCX]
	30	VYK5P92	FRONT CASE UNIT	1	ZS20P-R [PAVCX]
	30	VYK5P95	FRONT CASE UNIT	1	ZS20P-W [PAVCX]
	30	VYK5T71	FRONT CASE UNIT	1	ZS19 [PAVCX]
	30-1	VGK3873	GRIP PIECE	1	(-K) [PAVCX]
	30-1	VGK3875	GRIP PIECE	1	(-S,-W) [PAVCX]
	30-1	VGK3888	GRIP PIECE	1	(-T) [PAVCX]
	30-1	VGK3874	GRIP PIECE	1	(-R) [PAVCX]
	30-2	VGQ1B67	LENS ORNAMENT	1	(TZ30/31/ZS20) (-K/-T) [PAVCX]
	30-2	VGQ1B68	LENS ORNAMENT	1	(TZ30/31/ZS20) (-S/-R/-W), TZ27, ZS19 [PAVCX]
	31	EBMGSE21R5KA	GPS ANTENNA	1	(TZ30/31/ZS20) EG,EP,EF,EB,EE,GC,GA,SG,G N,P, PC,PU,GH,GT
	200	VXW1421	LENS UNIT (W/O CMOS)	1	(TZ30/31/ZS20) (-K/-T)
	200	VXW1441	LENS UNIT (W/O CMOS)	1	(TZ30/31/ZS20) (-S/-R/-W), TZ27, ZS19
	201	VEK0S59	CMOS UNIT	1	E.S.D.
	202	VMB4601	CMOS TILT SPRING	1	
	203	VMB4601	CMOS TILT SPRING	1	
	204	VXQ2215	FIX CAM FRAME UNIT	1	
	205	VDG1782	DRIVE GEAR	1	
	206	VXP3748	DRIVE FRAME UNIT	1	(TZ30/31/ZS20) (-K/-T)
	206	VXP3773	DRIVE FRAME UNIT	1	(TZ30/31/ZS20) (-S/-R/-W), TZ27, ZS19
	207	VXP3744	DECORATIVE FRAME UNIT	1	(TZ30/31/ZS20) (-K/-T)
	207	VXP3772	DECORATIVE FRAME UNIT	1	(TZ30/31/ZS20) (-S/-R/-W), TZ27, ZS19
	208	VXP3742	1ST LENS FRAME UNIT	1	(TZ30/31/ZS20) (-K/-T)
	208	VXP3771	1ST LENS FRAME UNIT	1	(TZ30/31/ZS20) (-S/-R/-W), TZ27, ZS19
	209	VXP3745	2ND LENS FRAME UNIT	1	
	210	VXP3746	3RD LENS FRAME UNIT	1	
	211	VXP3806	STRAIGHT FRAME UNIT	1	
	212	VDW2433	BOTH SIDE CAM FRAME	1	
	213	VDW2439	OUTSIDE CAM FRAME	1	
	214	VXQ2217	MASTER FLANGE UNIT	1	
	214-1	VZT1098	DOUBLE-STICK TAPE	1	[PAVCX]
	B1	XQN14+BJ35FN	SCREW	1	
	B2	VHD2205	SCREW	1	
	B3	VHD2205	SCREW	1	

Model No. : DMC-TZ27/TZ30/TZ31/ZS19/ZS20 Parts List

Safety	Ref. No.	Part No.	Part Name & Description	Q'ty	Remarks
	B4	VHD2205	SCREW	1	
	B5	VHD2205	SCREW	1	
	B6	VHD2081	SCREW	1	
	B7	VHD1759	SCREW	1	
	B8	VHD1759	SCREW	1	
	B9	VHD1759	SCREW	1	
	B10	VHD2207	SCREW	1	
	B11	VHD2207	SCREW	1	
	B12	VHD1998	SCREW	1	[PAVCX]
	B13	VHD2392	SCREW	1	[PAVCX]
	B14	VHD2392	SCREW	1	[PAVCX]
	B15	VHD2392	SCREW	1	[PAVCX]
	B201	VHD2388	SCREW	1	
	B202	VHD2388	SCREW	1	
	B203	VHD2388	SCREW	1	
	B204	VHD2390	SCREW	1	
	B205	VHD2390	SCREW	1	
	B206	VHD2390	SCREW	1	
	B207	VHD2390	SCREW	1	
	B208	VHD2390	SCREW	1	
	B209	VHD2390	SCREW	1	
	301	RFFW0057	CAMERA BAG	1	EXCEPT FOR P,PC
	302	VPK5271	PACKING CASE	1	(TZ30) (-K) EG,EP,EF,EB,EE,GC,GA,SG,GN
	302	VPK5275	PACKING CASE	1	(TZ30) (-S) EG,EP,EB,GC,GA
	302	VPK5278	PACKING CASE	1	(TZ30) (-T) EG,EP,EF,EE,GC,GA,GN
	302	VPK5283	PACKING CASE	1	(TZ30) (-R) EG,EP,EB,EE,GC,GA,SG,GN
	302	VPK5287	PACKING CASE	1	(TZ30) (-W) EG,EP,EF,EB,GA,SG,GN
	302	VPK5290	PACKING CASE	1	TZ31EG-K
	302	VPK5291	PACKING CASE	1	TZ31EG-S
	302	VPK5292	PACKING CASE	1	TZ31EG-T
	302	VPK5293	PACKING CASE	1	TZ31EG-R
	302	VPK5294	PACKING CASE	1	TZ31EG-W
	302	VPK5295	PACKING CASE	1	TZ27
	302	VPK5272	PACKING CASE	1	(ZS20) (-K) PU,GH,GT
	302	VPK5276	PACKING CASE	1	(ZS20) (-S) PU,GH
	302	VPK5284	PACKING CASE	1	ZS20PU-R
	302	VPK5279	PACKING CASE	1	(ZS20) (-T) GH,GT
	302	VPK5288	PACKING CASE	1	ZS20GT-W
	302	VPK5273	PACKING CASE	1	ZS20GK-K
	302	VPK5277	PACKING CASE	1	ZS20GK-S
	302	VPK5280	PACKING CASE	1	ZS20GK-T
	302	VPK5289	PACKING CASE	1	ZS20GK-W
	303	VQL1Z22	NTSC LABEL	1	PU,GT
	304	-----	BATTERY PACK	1	EXCEPT FOR P,PC,GK
	304	-----	BATTERY PACK	1	GK
	305	VFF0975	DVD (SOFT/INSTRUCTION BOOK)	1	(TZ30/31) EG,EP,EF,EB
	305	VFF0977	DVD (SOFT/INSTRUCTION BOOK)	1	EE
	305	VFF0978	DVD (SOFT/INSTRUCTION BOOK)	1	GC,GA,SG,GN,GH
	305	VFF1000	CD-ROM (SOFT/INSTRUCTION BOOK)	1	TZ27
	305	VFF0974	DVD (SOFT/INSTRUCTION BOOK)	1	PU
	305	VFF0979	DVD (SOFT/INSTRUCTION BOOK)	1	GT
	305	VFF0980	CD-ROM (SOFT/INSTRUCTION BOOK)	1	GK
	306	VSK0772	AC ADAPTOR	1	(TZ30/31/27) EG,EP,EF,EE,GA,EC
	306	VSK0775	AC ADAPTOR	1	(TZ30/27) EB,GC,GH
	306	VSK0771	AC ADAPTOR	1	SG
	306	VSK0776	AC ADAPTOR	1	GN
	306	VSK0768	AC ADAPTOR	1	PU
	306	VSK0769	AC ADAPTOR	1	GT
	306	VSK0770	AC ADAPTOR	1	GK
	307	VQT4B75	BASIC O/I (GERMAN/FRENCH)	1	(TZ30/31) EG
	307	VQT4B76	BASIC O/I (ITALIAN/DUTCH)	1	TZ30EG
	307	VQT4B77	BASIC O/I (SPANISH/PORTUGUESE)	1	TZ30EG

Model No. : DMC-TZ27/TZ30/TZ31/ZS19/ZS20 Parts List

Safety	Ref. No.	Part No.	Part Name & Description	Q'ty	Remarks
	307	VQT4B78	BASIC O/I (TURKISH)	1	TZ30EG
	307	VQT4B79	BASIC O/I (SWEDISH/DANISH)	1	TZ30EP, TZ27EC
	307	VQT4B80	BASIC O/I (POLISH/CZECH)	1	TZ30EP
	307	VQT4B81	BASIC O/I (HUNGARIAN/FINNISH)	1	TZ30EP, TZ27EC
	307	VQT4B82	BASIC O/I (FRENCH)	1	TZ30EF, TZ27EC
	307	VQT4B83	BASIC O/I (ENGLISH)	1	(TZ30/27) EB
	307	VQT4B84	BASIC O/I (RUSSIAN/UKRAINIAN)	1	TZ30EE
	307	VQT4B85	BASIC O/I (ENGLISH/CHINESE (TRADITIONAL))	1	(TZ30/ZS20) GC,GA,SG,GH
	307	VQT4B86	BASIC O/I (ARABIC/PERSIAN)	1	GC,GA
	307	VQT4B87	BASIC O/I (VIETNAMESE)	1	GA
	307	VQT4B90	BASIC O/I (ENGLISH)	1	GN
	307	VQT4B74	BASIC O/I (SPANISH/PORTUGUESE)	1	PU
	307	VQT4B88	BASIC O/I (CHINESE (TRADITIONAL))	1	GT
	307	VQT4B89	BASIC O/I (CHINESE (SIMPLIFIED))	1	GK
	308	K1HY08YY0025	USB CABLE	1	EXCEPT FOR P,PC
	309	VFC4297	HAND STRAP	1	EXCEPT FOR P,PC
	310	VPN7345	CUSHION	1	EXCEPT FOR P,PC
	311	VFF1230	BAG, POLYETHYLENE	1	EXCEPT FOR P,PC
	312	VQL2C68-1	OPERATING LABEL	1	GT
	401	RPFW0057	CAMERA BAG	1	P,PC
	402	VPK5270	PACKING CASE	1	(ZS20) (-K) P,PC
	402	VPK5274	PACKING CASE	1	(ZS20) (-S) P,PC
	402	VPK5282	PACKING CASE	1	(ZS20) (-R) P,PC
	402	VPK5286	PACKING CASE	1	ZS20P-W
	402	VPK5337	PACKING CASE	1	ZS19
	404	-----	BATTERY PACK	1	P,PC
	405	VFF0974	DVD (SOFT/INSTRUCTION BOOK)	1	(ZS20) P,PC
	405	VFF0999	CD-ROM (SOFT/INSTRUCTION BOOK)	1	ZS19
	406	VSK0768	AC ADAPTOR	1	P,PC
	407	VQT4B72	BASIC O/I (ENGLISH/SPANISH)	1	P
	407	VQT4B73	BASIC O/I (ENGLISH/CANADIAN FRENCH)	1	PC
	408	K1HY08YY0025	USB CABLE	1	P,PC
	409	VFC4297	HAND STRAP	1	P,PC
	410	VPN7345	CUSHION	1	P,PC
	411	VFF1230	BAG, POLYETHYLENE	1	P,PC
	412	VQL2C67	OPERATING LABEL	1	PC