

RICOH

RICOH

Ri 1000

User Manual



For safe and correct use, be sure to read the Safety Information in Safety Information and Quick Installation Guide before using the machine.

Version 1.3.0

Where to Inquire

For inquiries, contact your sales or service representative.

Contents

How to Read the Manual	6
Safety Symbols for This Machine	7
1 Before You Begin	8
1.2 Part Identification	10
1.3 Important	12
1.4 Installation	13
Space Needed for Printer	13
Setting Up Your Printer	14
1.5 Control Panel Functions	19
[Print Tab]	19
[Status Panel]	20
[Maintenance]	21
[Alignment]	22
[Service Part Status]	23
[Settings]	24
1.6 Configuring your printer via AnaRIP	25
[Firewall Settings]	26
[Configure your printers IP Address]	32
Configuring the printer's IP address (Windows)	33
[Adding a new printer to AnaRIP]	35
2 Preparing Media for Printing	37
2.1 Mounting Print Table onto Printer	37
2.2 Mounting Substrate onto Print Table	39
2.3 Setting the Print Table to Ready Position	41
[Moving Table]	42
3 Printing your image	44
4 Using AnaRip to Print Light Color Garments	48
4.1 AnaRIP Raster Image Processor	48
4.2 Printer Performance	49
4.3 AnaRIP Advanced features	60
4.4 Removing Garments from the Print Table	63
4.5 Set the Image with Heat	64
5 Using AnaRip to Print Dark Garments	65
Pretreating Substrates (light and dark)	65

[Pre- treatment Application Procedure]	66
5.1 Underbase	68
5.2 Underbase Tab Settings	69
5.3 Underbase Adjustments	72
5.4 Choke	74
5.5 Pure White	76
5.6 Select Border Color to be Removed.....	78
5.7 Set the Image with Heat Treatment	79
6 Maintenance	80
6.1. Nozzle check.....	81
6.2. Automatic Head Cleaning	83
White Clean Freq.	84
6.3 Manual Head Cleaning	85
6.4 Agitating White Cartridge	87
6.5. Circulation	89
6.6. Empty the Waste Ink Bottle.....	89
7 Adjustments	90
7.1 Adjusting Head	91
7.2 Adjusting Table.....	95
7.3 Adjusting the print position	97
8 Replacing Service Parts	99
8.1 Service part	99
8.2 Maintenance Schedule	100
Daily	100
Weekly	102
How to Clean the Maintenance Unit and the Flushing box.....	104
How to Clean the Cover of Head Nozzle Plate (the Nozzle Cover)	113
How to Clean the Guide Rod and the Encoder Strip.....	119
8.3 Preparing Your Printer for Storage/Shipping	128
8.4 Using Printer in 4-color mode (CMYK Only)	129
8.5 Ink Path Guide	130
9 Updating Firmware	131
9.1 Updating Firmware	131
10 About Open Source Software License.....	136
11 Troubleshooting Guide.....	137

How to Read the Manual

Disclaimer

Contents of this manual are subject to change without prior notice.

To the maximum extent permitted by applicable laws, in no event will the manufacturer be liable for any damages whatsoever arising out of failures of this machine, losses of the registered data, or the use or non-use of this product and operation manuals provided with it.

Make sure that you always copy or have backups of the data registered in this machine. Documents or data might be erased due to your operational errors or malfunctions of the machine.

In no event will the manufacturer be responsible for any documents created by you using this machine or any results from the data executed by you.

Notes

Read this manual carefully before you use the product and keep it handy for future reference.

For safe and correct use, be sure to read Safety Information before using the machine.

The manufacturer shall not be responsible for any damage or expense that might result from the use of parts other than genuine parts from the manufacturer with your products.







For good output quality, the manufacturer recommends that you use genuine ink from the manufacturer.

Some illustrations in this manual might be slightly different from the machine.

Certain options might not be available in some countries. For details, please contact your local dealer. Depending on which country you are in, certain units may be optional. For details, please contact your local dealer.





Safety Symbols for This Machine



The meanings of the safety symbols for this machine are as follows:

	Caution
	Prohibition
	General mandatory action sign
	Do not touch
	Caution, risk of having hands or arms caught
	Caution, risk of electric shock
	Caution, hot surface

1 Before You Begin

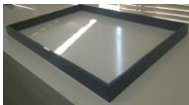
Accessory Box Contents:

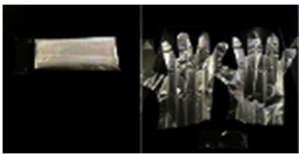
Power cord	1	
Ethernet cable	1	
Waste Bottle	1	
Waste tube	1	
Medium Platen	1	
Medium frame	1	

Maintenance Supplies		
Cleaning Liquid	1	
Cleaning Applicators	1	
Lint Free Wipes	1	
Heat Press Paper	1	
Grease	1	
Polyethylene gloves	5set	
Squeegee	1	
Manual		
Safety & Quick Installation Guide	1	

1.2 Part Identification

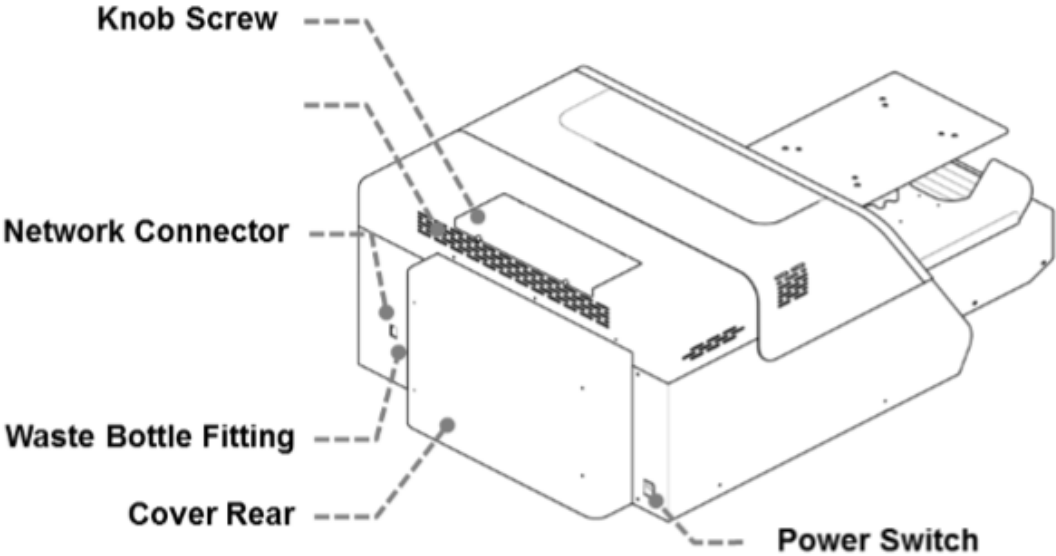
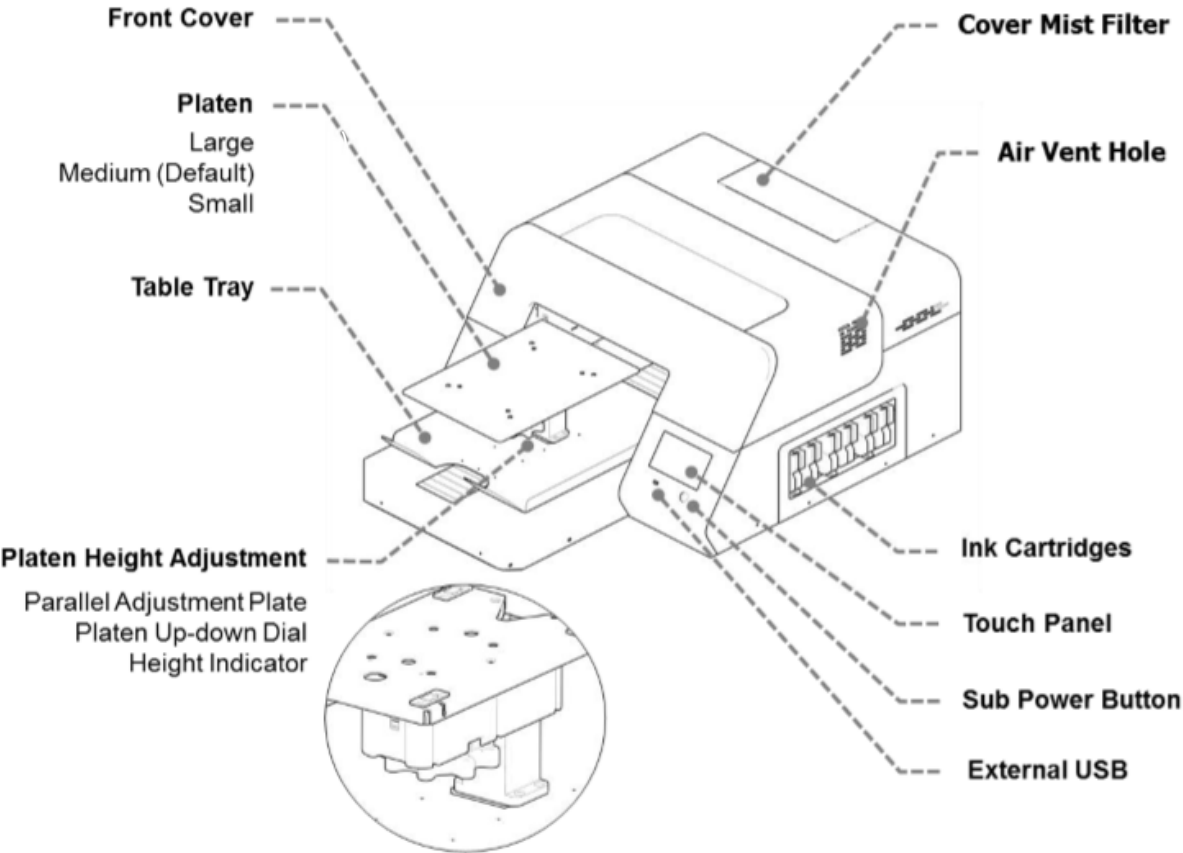

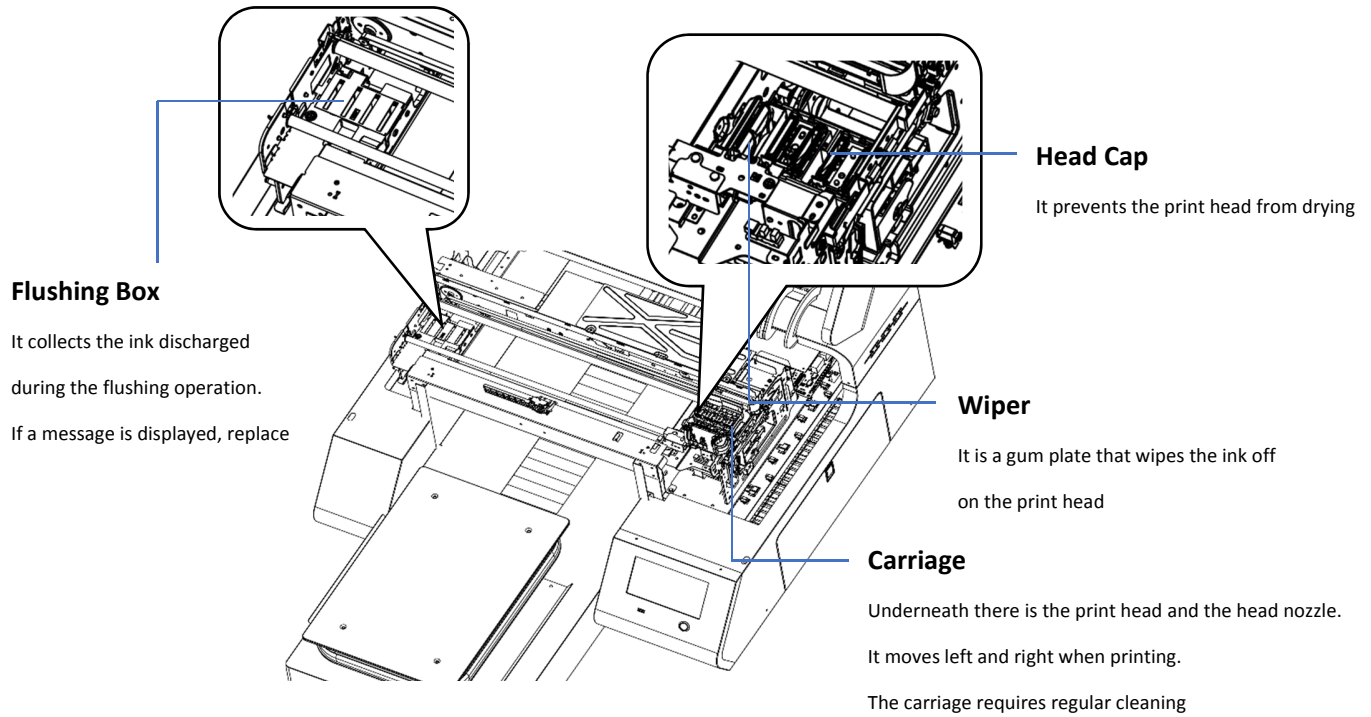

1.3 Important

- **DO NOT POWER OFF THE PRINTER**
This printer periodically circulates ink internally and automatically performs head cleaning. If you keep the printer power off for a long time (more than 12 hours), it will require charge/fill the printer with cleaning solution.
- Perform maintenance as outlined in the maintenance schedule
The printer will perform automatic maintenance periodically. But if you do not maintenance periodically, the ink in the cartridge could settle and/or coagulate, causing poor image quality or printer failure.
- Some parts require periodical replacement
This printer includes parts that require replacement due to usage.
Parts that must be replaced by a service representative.
- If the printer encounters an error message, be sure to resolve the issue before continuing use as the self-maintenance functions will not work if there is a current error being experienced by the printer.

1.4 Installation

Space Needed for Printer

Installation
Space:
Top View

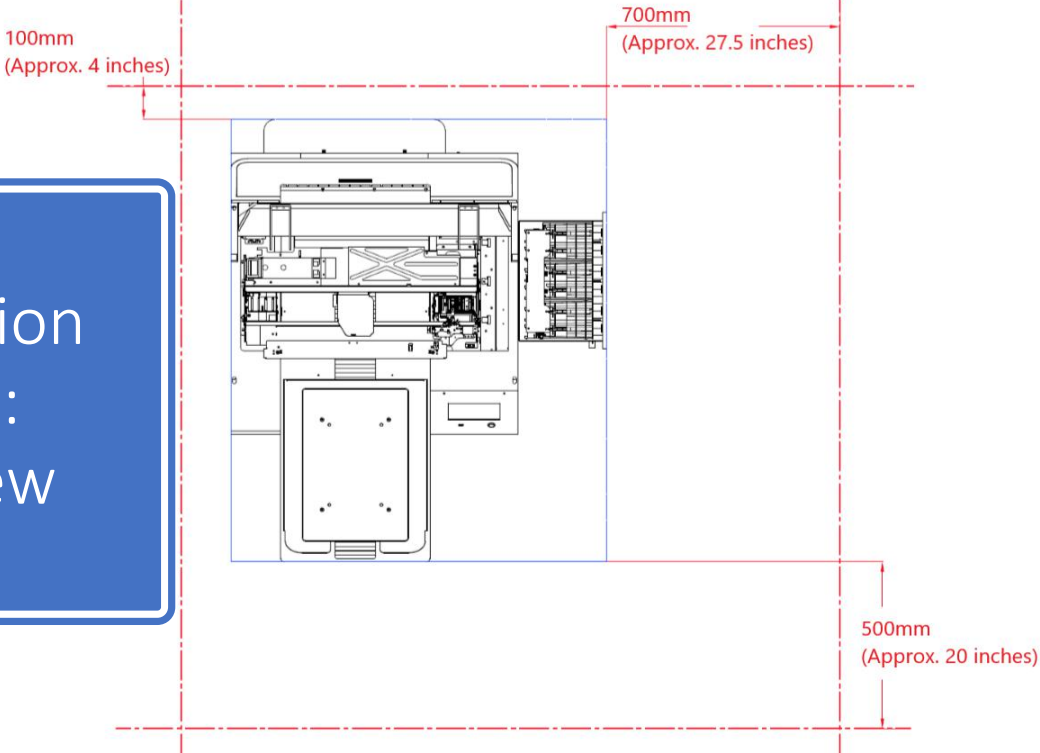

Installation
Space:
Side View

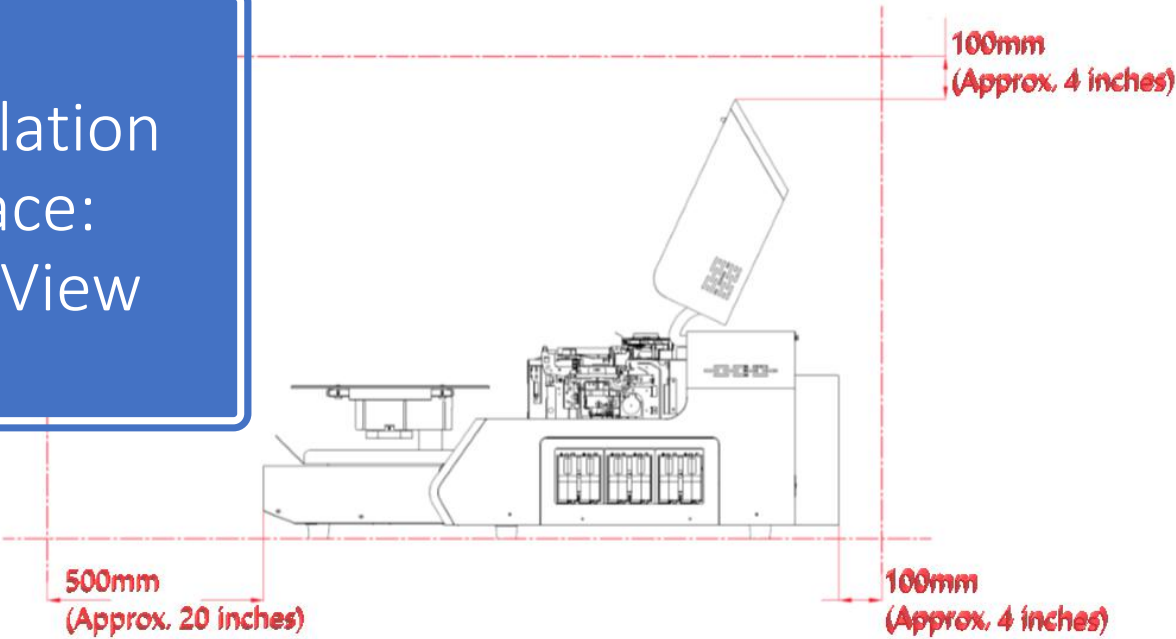

Setting Up Your Printer

1.



Table in printer is secured by Foam block. Please remove before startup

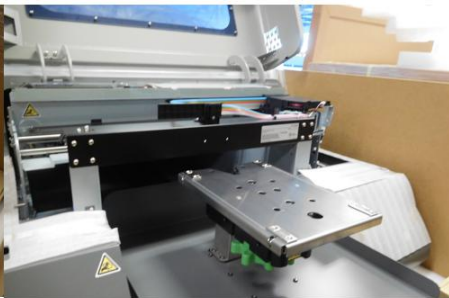

Hold foam block on the side and gently pull forward. With block removed, continue with set up steps as described in the **user manual**.

Your printer has a towelette taped over the waste drain valve use the following steps:

Remove tape and towel from drain connection



Slide drain tube through cap until it meets with the zip-tie



Screw Cap onto bottle



Secure the Waste Ink Bottle



Insert opposite end of drain tube into drain connection

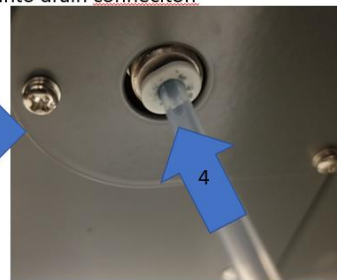

If needing to remove drain tube, use the below instructions:

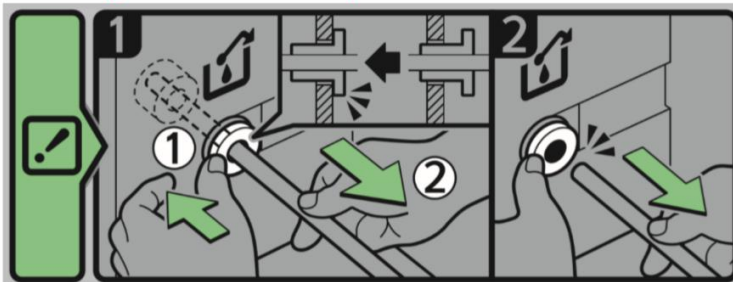

- 1) **GENTLY** push plastic ring in using either two fingers or small flathead screwdriver
- 2) **GENTLY** pull the tube away from the plastic ring, NOTE: tube should come out with *minimal* force.
 - * Drain tube should not be removed unless required for movement of equipment or replacement*
 - ** It is recommended to keep drain tube installed unless absolutely necessary**

DO NOT PULL TUBE

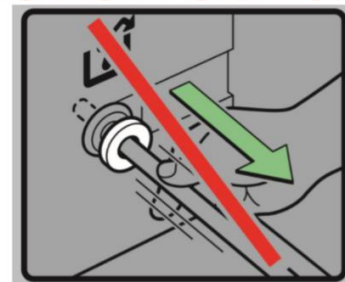

ATTENTION

The printer cannot determine if the waste ink bottle is connected, please make sure the waste ink bottle is connected properly

During the initial ink charge, if the cover is opened, it will pause the procedure. To resume, hold the power button down to reboot the printer

1. Connect the power cable to the back of the printer and to a functional wall outlet

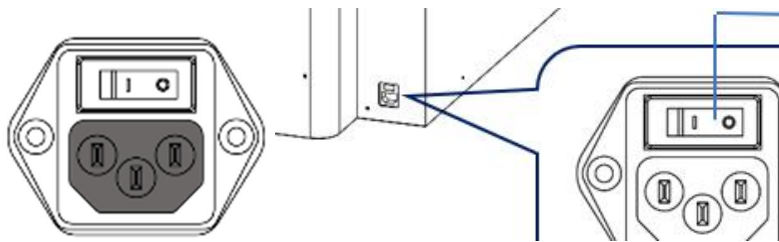

[AC Power Connector]

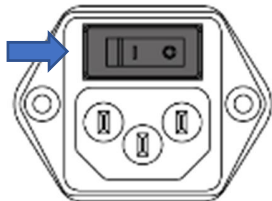

[AC Power Switch] [Power On/Off]

ATTENTION: Please agitate the White 1 and White 2 Cartridge before inserting them into the

printer and initiating the fill process.

Agitating new White Cartridge

Please agitate white ink before setting a new white cartridge in the printer.

The stirring method should follow the following.

CAUTION:

DO NOT hit or drop it when stirring. As it may cause injury, cartridge damage, ink leakage.

DO NOT excessively agitate/shake. as it may cause ink leakage.

MUST AGITATE/SHAKE as instructed. Other methods may cause ink leakage.

- Hold the cartridge as shown in Fig. 1.
- Shake the cartridge in the direction of rotation left and right as shown in Figure 1.
- Make the ink cartridge reciprocate for 50 seconds in the direction of rotation of the arrow in Figure 1 in the left and right directions.
- Shake speed is the speed to make two reciprocations per second.



Fig. 1

Warning

DO NOT shake cartridge too fast or hardly.

2. Insert ink cartridges

- ❖ *Please note, each cartridge is designed for its corresponding slot. WH1 will go in the first slot (closest to the control panel) then WH2 then Black, Cyan, Magenta, and lastly Yellow towards the back of the printer*

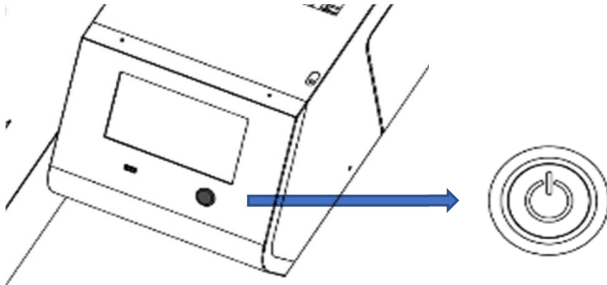

3. To power **on**, after flipping the I/O switch to | (on I), hold down the power button on the front near the LCD screen, for 3 seconds

- ❖ *To power off, hold down the power button on the front near the LCD screen, for more than 3 seconds and return the I/O switch to O (off)*

4. The printer is starting to boot.
5. After booting, the printer will perform initial charging if the printer is not charged.
 - ❖ *Initial charging takes about 15-20 minutes and the display will show a status percentage (%)*

ATTENTION

During the initial ink charging, don't open front cover or cartridge cover.

6. Once the initial charge is completed, the printer will show READY in the upper left-hand corner of the LCD screen



1.5 Control Panel Functions

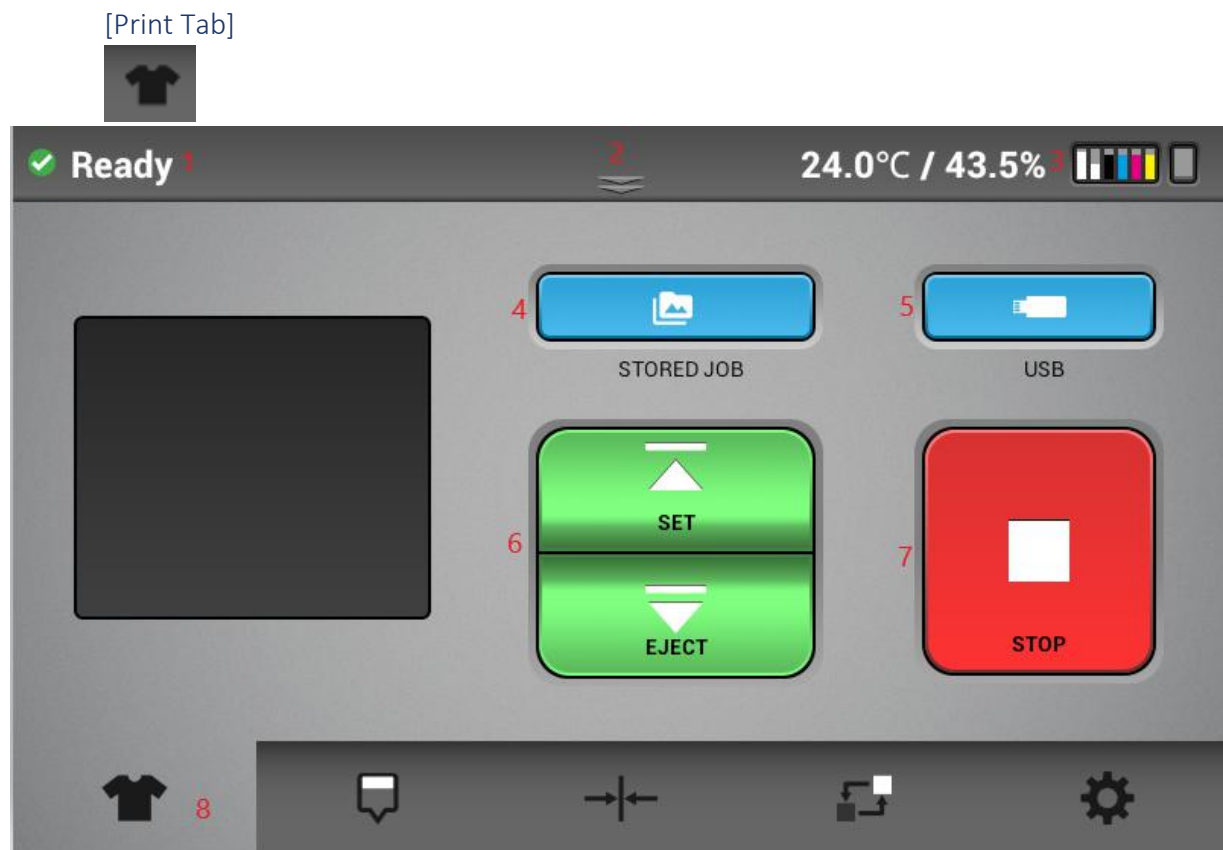

- ① Displays the printer status.
- ② Status Bar- TAP/Drag down to open status screen menu (shown below)
- ③ Displays printer temperature, amount of ink in ink cartridges and waste bottle capacity level.
- ④ Stored Job folder- Check the recent images used for printing. Print directly from the stored folder or from jobs sent via network cable
- ⑤ Choose print job from USB device
- ⑥ SET/EJECT- will move the table into the print ready position (table to the rear of the printer) or EJECT the table to allow the media to be place onto the table.
- ⑦ STOP- will stop any current movement of the table and allows to cancel print job
- ⑧ Function Tabs

[Status Panel]



- ① Displays the printer status in detail, providing print readiness.
- ② Displays current ink levels in each installed cartridge
- ③ Displays the status of waste ink bottle.
- ④ Reset counts of waste ink bottle. Press the icon to initialize the waste ink bottle once waste ink tank is manually drained/emptied

[Maintenance]



- ① Prints a nozzle check pattern result
- ② Performs head cleaning automatically using systems components
- ③ Allows carriage to be released, cover can be opened to manually clean the printheads (during maintenance or troubleshooting) and the maintenance station

[Alignment]

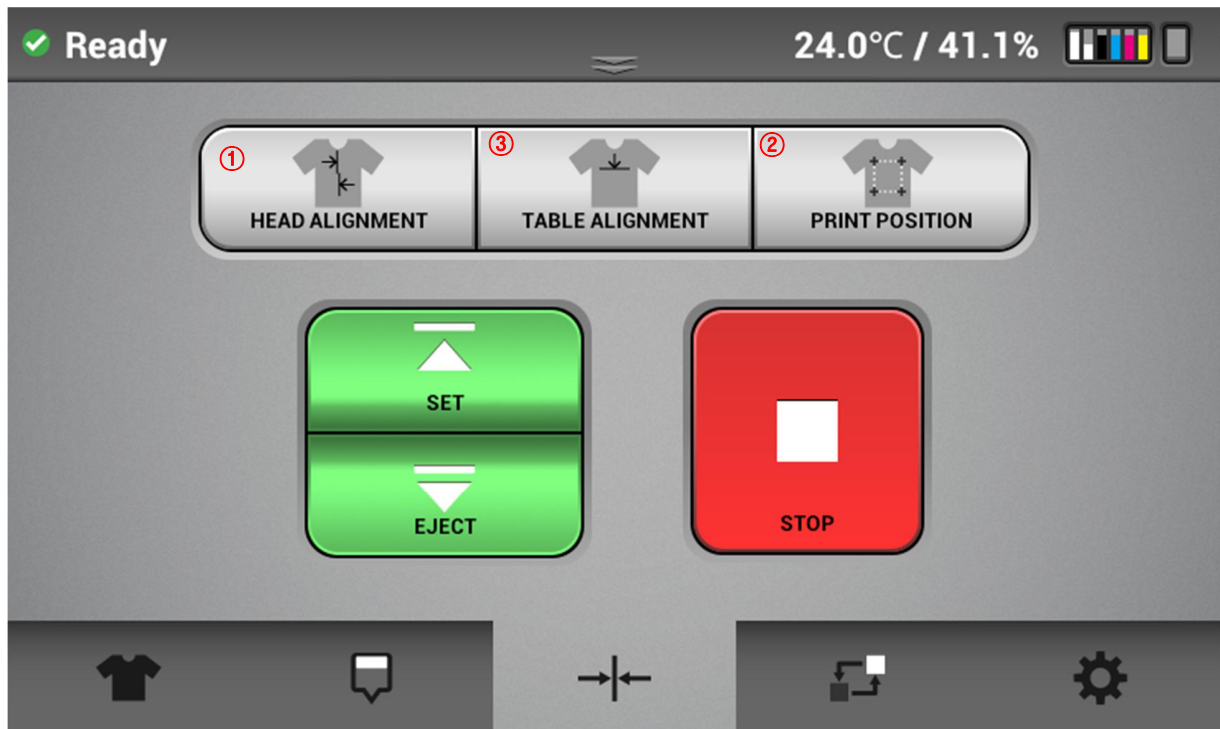

- ① Prints an adjustment pattern for the print head alignment of bi-directional printing
- ② Prints an adjustment pattern to table to carriage alignment
- ③ Prints an adjustment pattern to determine print start position or image alignment during print

[Service Part Status]

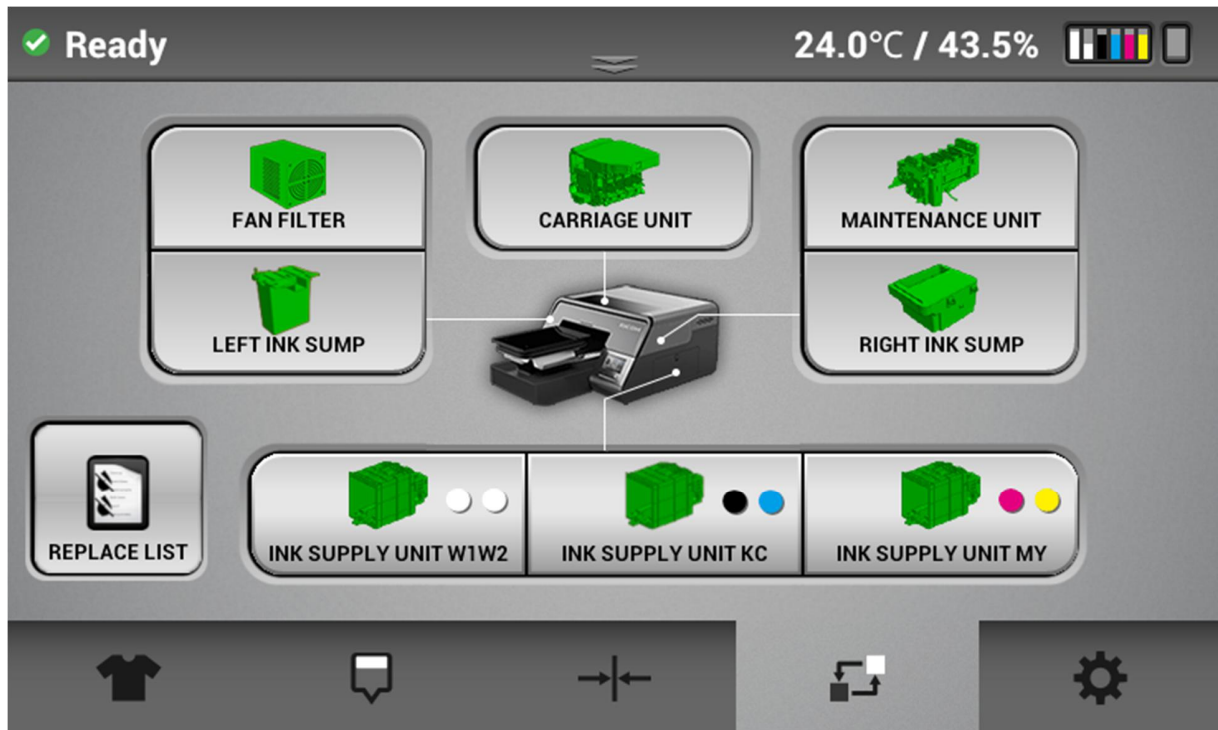

- Displays the current usage or status (Green, Yellow, Red). You can check the part replacement history by pressing the "REPLACE LIST" button.

[Settings]



- ① Perform controls of ink path.
- ② Network setting, factory reset, on/off media sensor, dry time, temperature toggle (C/F), High Speed mode, white clean freq.
- ③ Display printer general information.

1.6 Configuring your printer via AnaRIP

Prior to setting up your printer, you will need to download the latest version of AnaRIP software for your printer. You can find this software at www.AnaJet.com/downloads . Locate the latest version of AnaRIP for your specific printer. You will then be routed to a page with download and installation instructions.

Printer Software Program Requirements

Once the ink cartridges are installed and ink flow has been established, it's time to install the AnaRIP software onto the PC. Your PC must have Microsoft Windows Vista, Windows 7, Windows 8, or Windows 10 operating system, or on a MAC, some kind of Windows emulation must be running such as Parallels or Boot Camp. The computer also needs to have an ETHERNET port

When the software is installed double click the AnaRIP icon to launch the software and then connect the printer to the computer using the provided ETHERNET cable.

[Firewall Settings]

- ① From the WINDOWS control panel dialogue box, select WINDOWS DEFENDER FIREWALL

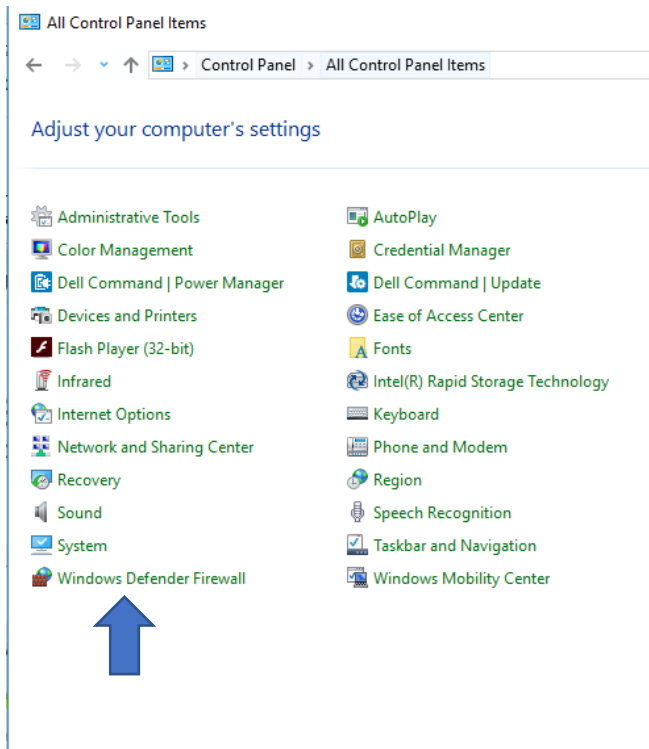

- ② Select the INBOUND RULES in the left frame of the dialogue
- ③ Then select NEW RULE in the ACTIONS BOX

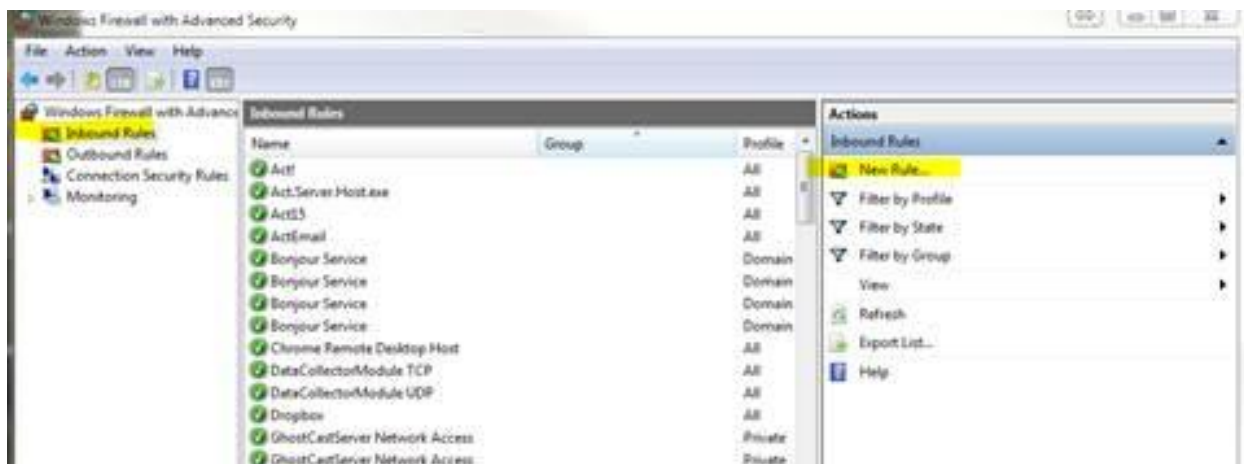

- ④ Select PROGRAM and click NEXT

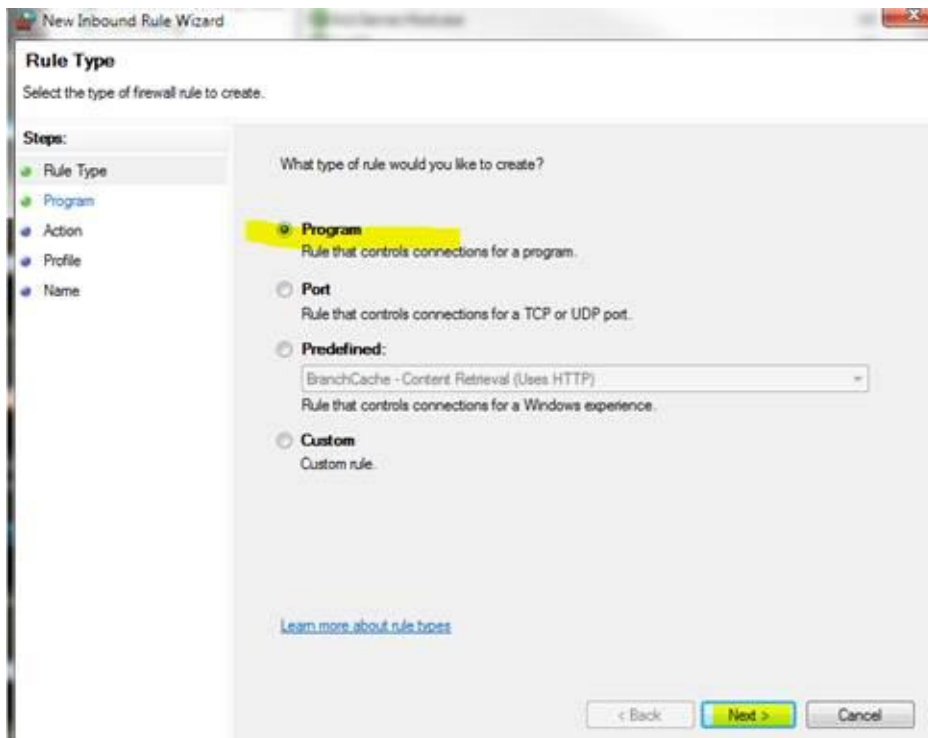

- ⑤ Type the path of the program (e.g. C:\Program Files (x86)\AnaJet\AnaRIP\AnaRIP.exe) or browse to it via the BROWSE button

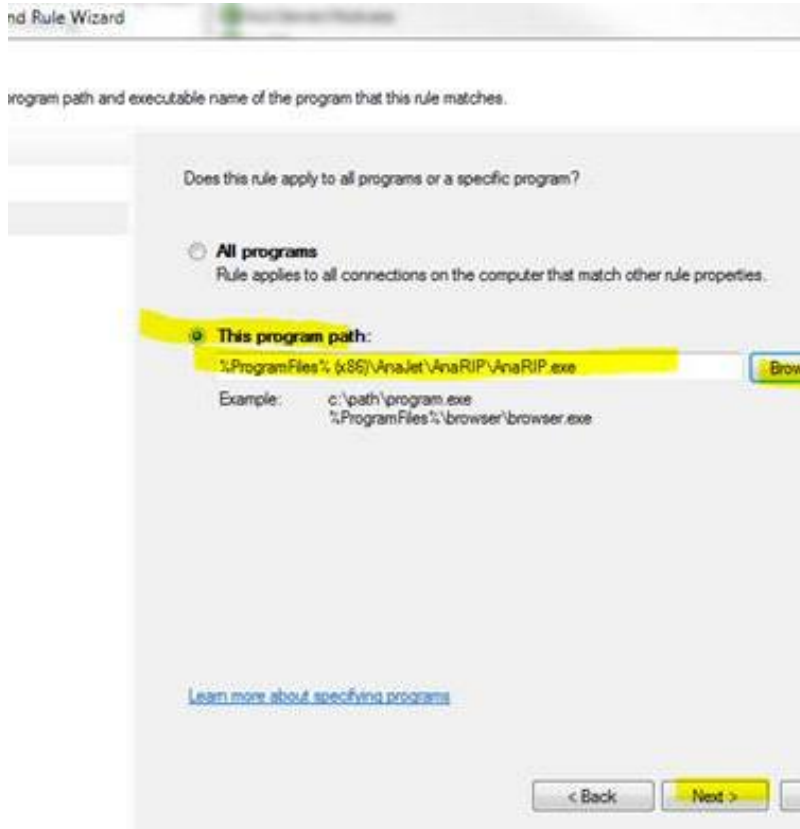

- ⑥ Select NEXT once the file path has been selected

- ⑦ Select the ALLOW THE CONNECTION radial button and click NEXT

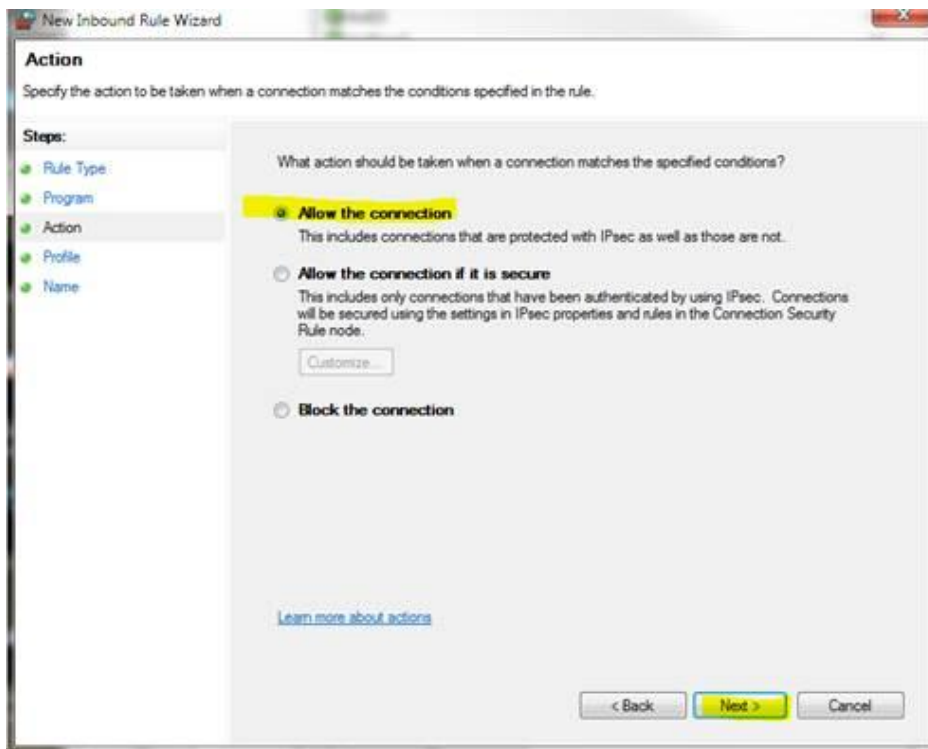

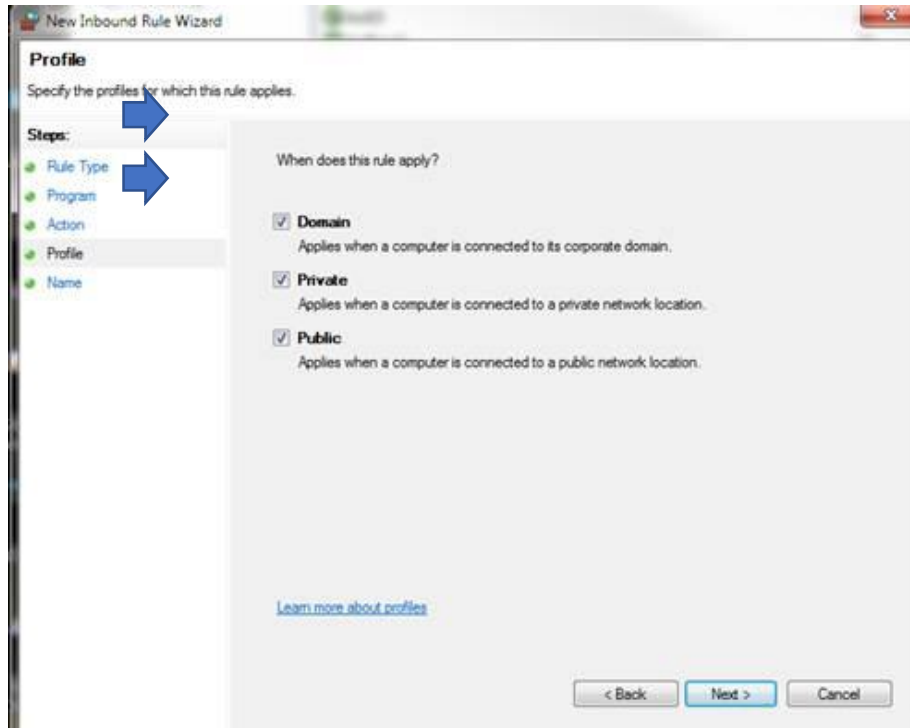

- ⑧ CHECK the box of the correct PROFILE when this should be applied
it is suggested to check DOMAIN and PRIVATE

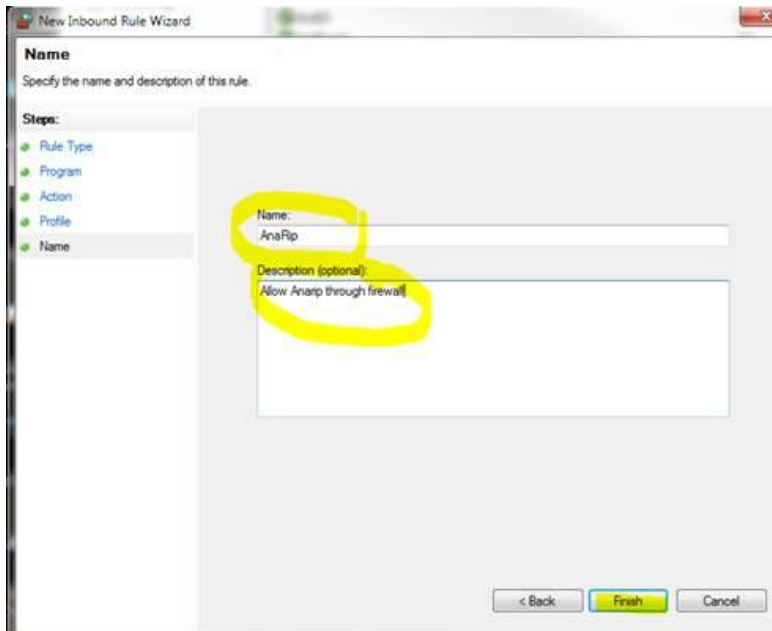

- ⑨ Name the rule and add a description (optional) then select FINISH when completed

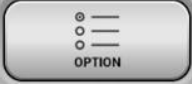

[Configure your printers IP Address]

- A. Go to the settings cog on the Ri 1000 
- B. Select the OPTION under the settings tab 
- C. Select the IP ADDRESS option in the menu dialogue box 
- D. Enter the STATIC IP ADDRESS the printer will be using
 - ❖ **NOTE: Printer must be directly connected to a laptop/desktop device via the provided ethernet cable.**
 - ❖ **For a DYNAMIC setup, enable the DHCP as shown below to add the printer to an existing network**

Example:



Configuring the printer's IP address (Windows)

- Connect the provided ethernet cable to the PC's ethernet port and to the printers ethernet port



- **For connecting directly to the printer from a PC that is not parts of a network.** Open the command prompt dialogue box

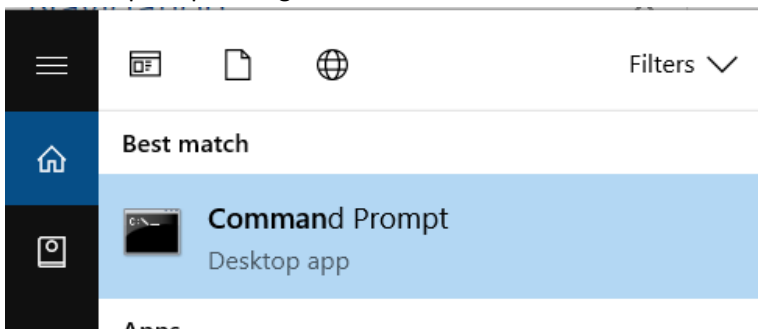

- Type **IPCONFIG** in the first line in the command prompt

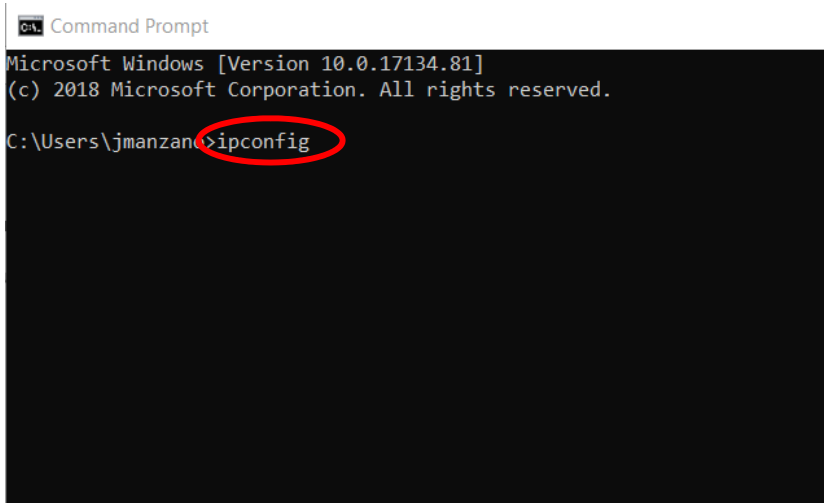

- In the **Ethernet Adapter Ethernet** section, use the IP address but change the last 3 digits to a number that will be unique to the printer and the Subnet Mask. In the example below, we took the XXX.XXX.XXX.172 and will assign 169.254.248.174 to the printer

```
Ethernet adapter Ethernet:  
Connection-specific DNS Suffix . :  
Link-local IPv6 Address . . . . . : fe80::fd62:86d1:6204:f8ac%10  
Autoconfiguration IPv4 Address. : 169.254.248.172  
Subnet Mask . . . . . : 255.255.0.0  
Default Gateway . . . . . :
```

- Enter the **new** IP address and the subnet mask into the printer by going to the settings tab, options **IP Address (DHCP must be disabled)**

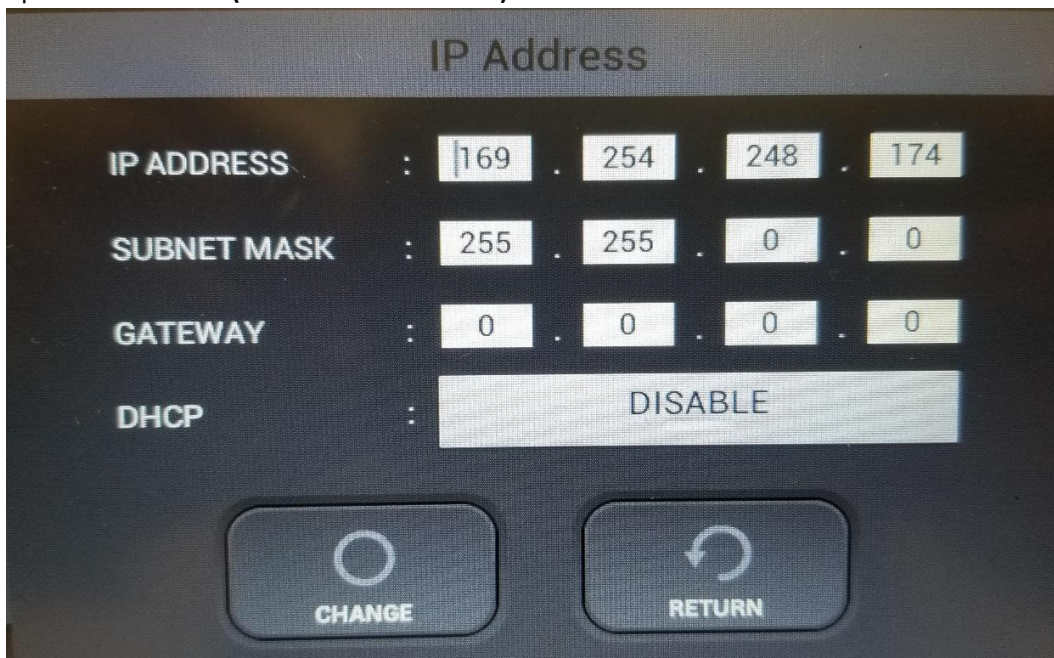

- Select the change option and make sure **DHCP** is disabled

[Adding a new printer to AnaRIP]

To utilize a connected printer via Ethernet, new printers must be added via the Manage Printers in the View section of the RIP.

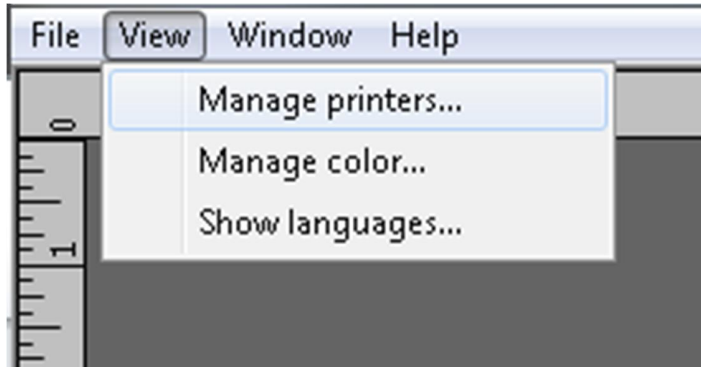

View Manage Printers

**By default, the AnaRIP software will have the Ri 1000, 3000 (mP5) and 6000 (mP10) FILE listed as options.*

- ① In the MANAGE PRINTERS dialogue box, select the ADD PRINTER BY ADDRESS

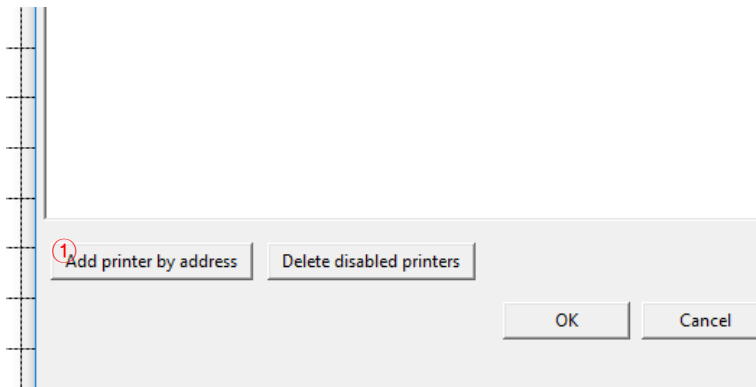

- ② Enter the IP ADDRESS for the printer
- ③ Click CHECK to confirm the IP ADDRESS is correct

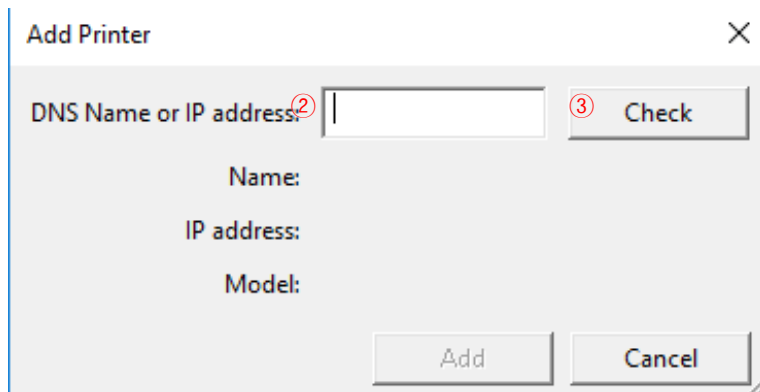

- ④ Click ADD once IP ADDRESS is confirmed and correct
- ⑤ Confirm the IP address matches the information on the printer

2 Preparing Media for Printing

2.1 Mounting Print Table onto Printer

- The Table is mounted on the table base using magnets shown below in black

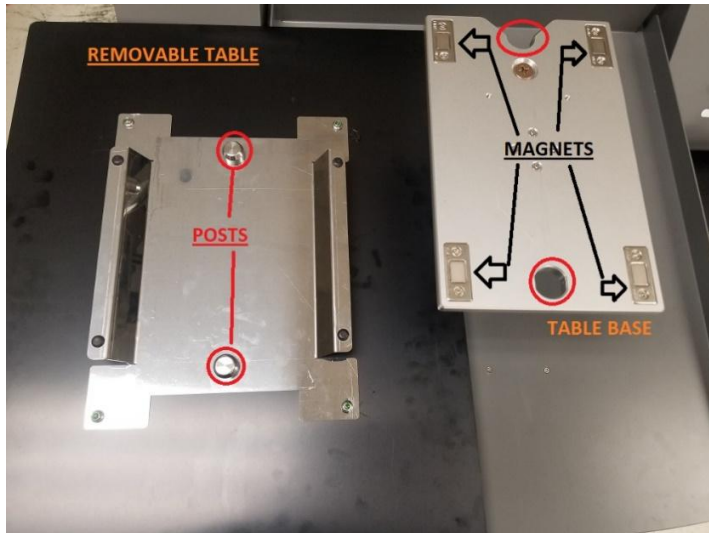

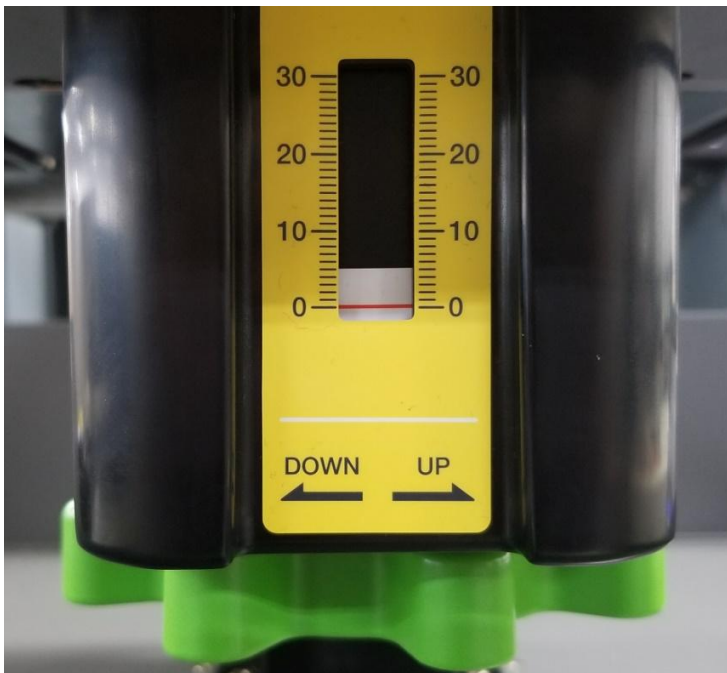

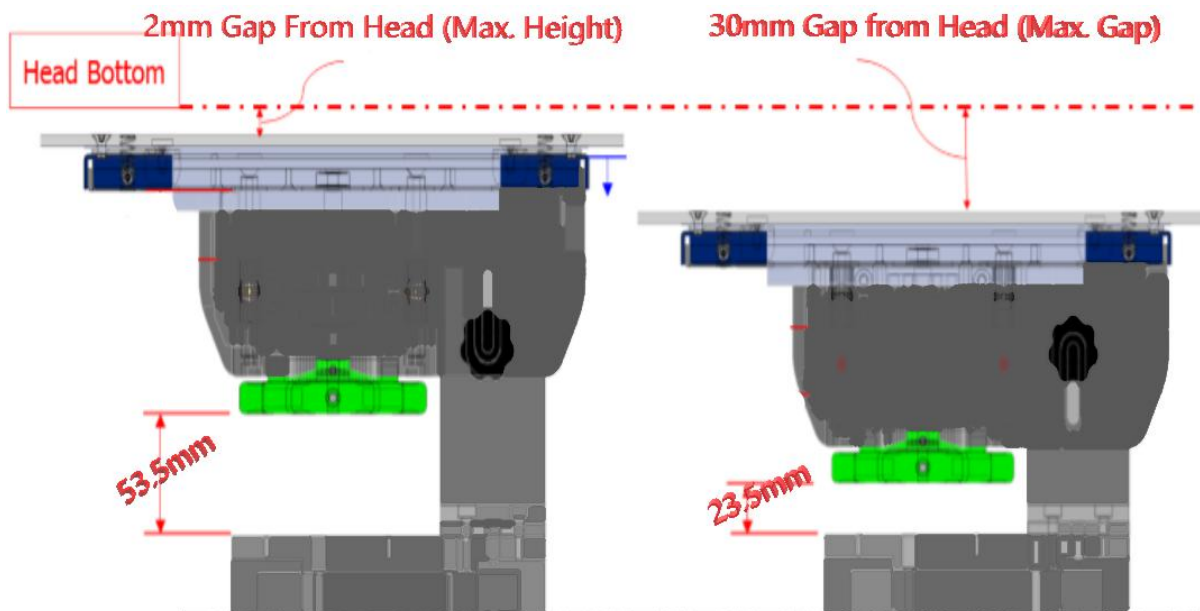

- Turn the height adjustment knob to manually move the table up by turning the knob to the LEFT or down to increase the gap between the printhead and the table (for thicker substrates)
Turning the knob to the RIGHT or up will move the platen up towards the printhead (to achieve best print quality, get **garment printing surface** within 1.5mm of the printhead carriage).
- For T shirts, having table set to zero will allow for best results

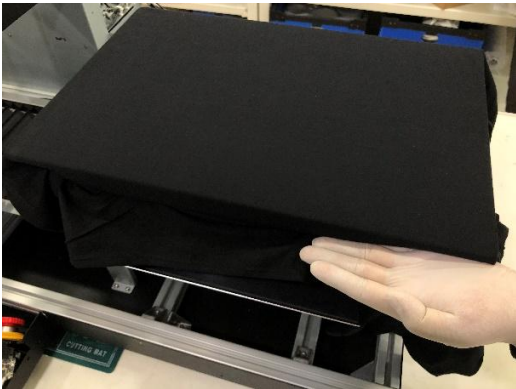

2.2 Mounting Substrate onto Print Table

- Place the substrate on top of the table then place the table hoop back over the substrate and table
 - ❖ ***Sleeve or dress the shirt on to the table so that only one piece of the garment is laying flat on top of the table, pull garment from the sides, front and back to ensure no wrinkles are present, Wrinkles may cause head strikes to occur (pre-press shirts prior to printing to allow for a flatter surface)***
 - ❖ ***Note: Table hoop may not fit around thicker garments***



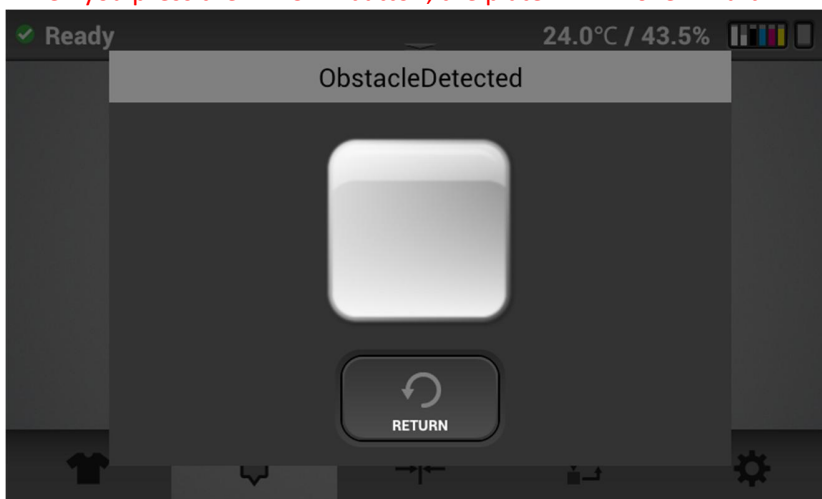

- Click SET  with the garment as flat as possible.
- 1st try flattening garment (easiest if dressed)
**Lower the table when the ObstacleDetected indicate with orange color.
Color will be turn white when close to the Ideal table hight position .
When you press the RETURN button, the platen will move inward.**



- ❖ If an obstacle is detected by the sensor, an orange message is displayed. It is a message that the head and the obstacle will collide if the height of this table is kept. You need to lower the table.



- ❖ Press the EJECT  button, then the SET  to confirm the obstruction has been cleared.
- ❖ **Note: Having the table too far away will affect image quality.** Ideally the garment will be 1.5mm away from the print head. When initially setting the table height, you should raise the table until you get the obstruction detected message then only lower the table slightly. Once the table height has been set in this way you should not need to adjust the table height again unless you are changing the substrate you are printing on (from T-shirt to sweat shirt for example)
- ❖ For this reason, when you get an obstruction message, you should always try to flatten the garment to clear the obstruction before lowering the table.
- ❖ **Caution: Having the head too far away from the printing surface in addition to causing poor prints can interfere with the encoder function and cause an error due to excessive ink mist. It can also cause damage to other components due to excessive ink mist. It is important when changing from a thicker fabric to a thinner fabric that the table height be adjusted.**

2.3 Setting the Print Table to Ready Position

- By clicking SET it will bring the table into the printer
- During this process, an optical lens will scan the top of the table
- If the obstruction detection determines an obstruction, you will need to flatten the garment or lower the table slightly



[Moving Table]

[Set]



- This button moves the table into print position
 - ※ If the table is stops during this process, the system has detected an obstruction and will need to be cleared

[Stop]



- This button is used to stop the printer during movement. If you press stop. The screen below will show up and you will be prompted to cancel the print or continue printing.

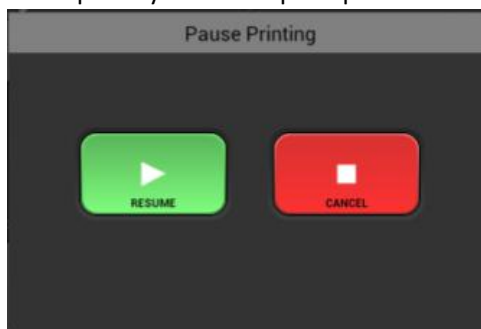

[Eject]

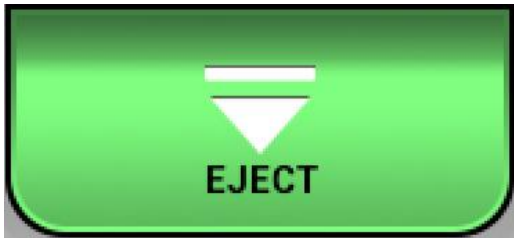

- This button is used to EJECT the table and prepare it for another substrate.

3 Printing your image

Once you have made all of your adjustments to the printing Size, Position, Quality and Color Adjustments you are ready to save your design or print your image. See section 4 for light shirts and 5 for dark shirt details on how to prepare the image

1. Load the substrate onto the table as described in **section 2.3**
2. Confirm the table height is correct and there are no obstructions detected
3. With the garment on the table press the SET  button
4. The **Status Bar** will show **READY** in the upper left-hand corner. If the status bar shows anything else such as maintenance or ink error etc., you will not be able to print

You can print in three ways

- 1) Send the printable file from the PC through the ethernet port. This is done by selected the printer in AnaRIP and pressing the print button (Details in section 5) The job ready to print will show in the preview window.



2) Selecting a job from the USB flash drive

Insert USB Drive into front USB port



Tap the USB icon



Tap the desired file to print then select the PRINT icon

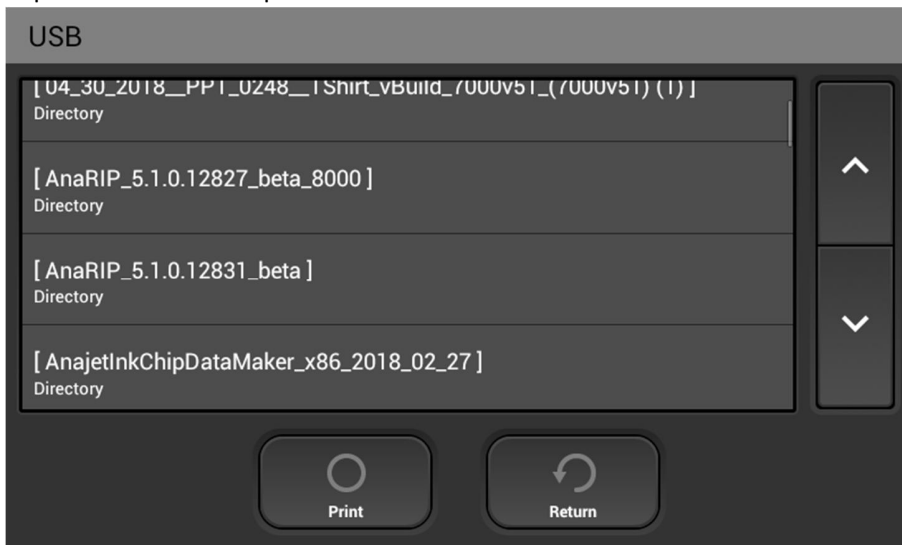

The selected print will be displayed in the thumbnail preview



- 3) Print from the internal memory. Jobs previously sent from the PC will be stored in internal memory

Tap the Stored Job Icon

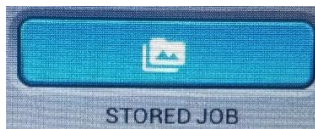

Tap the desired file to print then select the PRINT icon

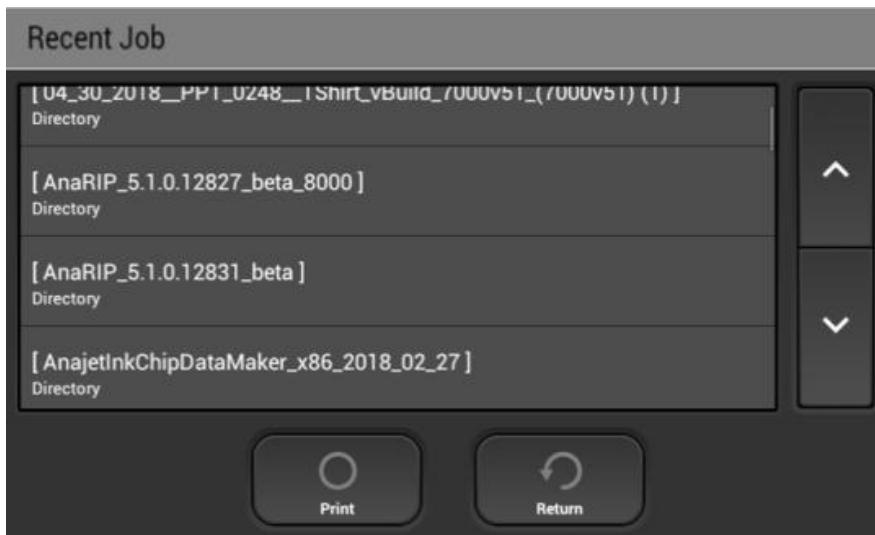

The selected print will be displayed in the thumbnail preview

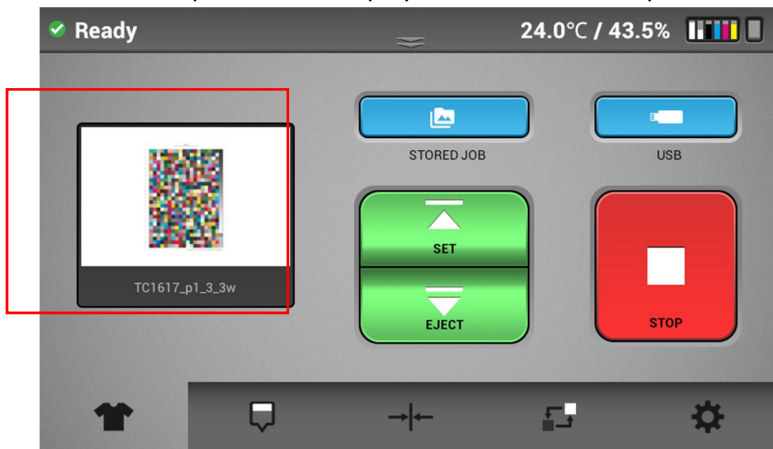

- 4) To CANCEL a print job press the  button during the print, the following dialogue box will appear

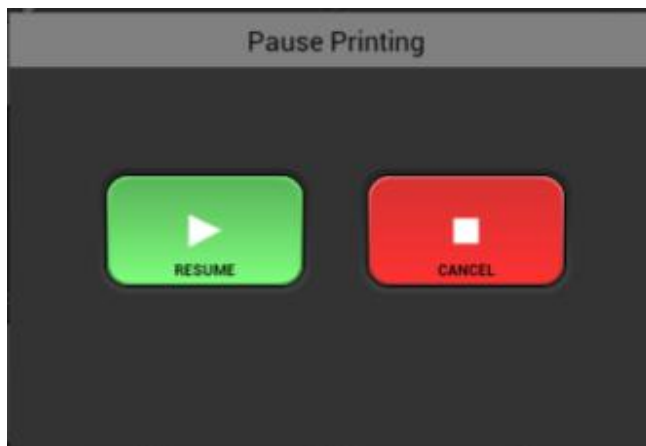

Then select the CANCEL button to stop the current print job.



Front USB Input Slot

When sending the print job directly through **ethernet** and the substrate are SET and in the READY position, the job will print once successfully transmitted from AnaRip

Ethernet Port

A file that has been previously sent directly to the printer can be retrieved from the printer's Internal Storage for reprinting Select Job from Internal Storage. You can now scroll through all of the print jobs and select the file you want to

4 Using AnaRip to Print Light Color Garments

4.1 AnaRIP Raster Image Processor

Ri 1000 AnaRIP printing software is provided for online download at: <http://AnaJet.com/downloads> . AnaRIP is a raster image processor (RIP); it is software which converts the graphic design to bitmap data suitable for printing. In the process, smoothing or interpolation algorithms are applied to the graphic data, ink drop size and exact placement of inkjet ink drops are determined. Thus, the quality of the RIP program used greatly affects the quality of print. Generally, RIP programs are difficult to learn and operate in a production environment. AnaJet has created a powerful RIP program with AnaRIP that is optimized for apparel printing.

- ❖ For optimum results below are the suggested image file settings:
 - Minimum 300 DPI
 - Canvas size 16 x 20 (maximum/Large Platen)
 - Images to be designed in CMYK color mode best Color accuracy
 - Recommended file types for LIGHT shirt printing are; .PNG, TIFF, JPEG
 - Recommended file types for DARK shirt printing are; .PNG and TIFF as they support transparency features and allow for a much more commercially acceptable print
 - AnaRip is able to accept many other file types including but not limited to; PDF, AI, PSD, and GIF

4.2 Printer Performance

Before you start a print job you will want to make sure you have proper ink flow and print quality to assure the best results. This will require that you perform a Nozzle Check, possibly followed by a Print Head Clean if needed. Before printing make sure that you have gone through all of the setup procedures before this chapter. This first thing you will need to do is a Nozzle Check. The Nozzle Check is going to show you how the Print Head Nozzles are performing and if it will require any Print Head Cleans to restore nozzles that are missing. Each color channel must be 100% of the total nozzles to be acceptable, white channels can have a missing nozzle. The intelligent auto clean feature will keep your printer at ready position. Having a good Nozzle Check will give you the best quality prints. Missing nozzles and a poor Nozzle Check will result in low quality prints. If the Nozzle Check is good, then you can now begin printing. If the Nozzle Check is bad you will need to perform a Print Head Clean This will then be followed by another Nozzle Check to ensure the performance print head nozzles. If the performance is still not acceptable repeat this process.

The definition of a light garment is any print that does not use white ink. The general rule to determine whether you need white or not is the colors of the image you will print. If those colors are darker than the color of the substrate you are printing on, white ink is not required.

You will now need to have a graphic that is ready to be placed into the AnaRIP software. You should design your images at the full size that they will be printed with a resolution between 100-300 DPI and a canvas size of 16x20 or smaller (depending on platen size).

The AnaRIP software has a limited number of possible file types you can use. They are JPG, TIFF, and PNG. We recommend that you prepare your images as TIFF or PNG file types. The TIFF and PNG formats both support transparencies generally required for dark shirt printing and use lossless compression that will keep your file high quality.

It is also good practice to avoid saving images as JPG. These are compressed file formats originally design for internet use only that loose quality every time they are re-saved. If you are using the native Adobe file formats of AI or PSD you must flatten all of the layers of you image and save this version for printing your complete image.

Open theAnaRIP program from your desktop.

Once the program is open you can now place the graphic you would like to use by selecting Place Image under the File drop down in the upper left corner of the program. You may also drag and drop a graphic into the program by clicking on the file and dragging it onto the preview are of the AnaRIP software.

- Your graphic should appear in the preview screen

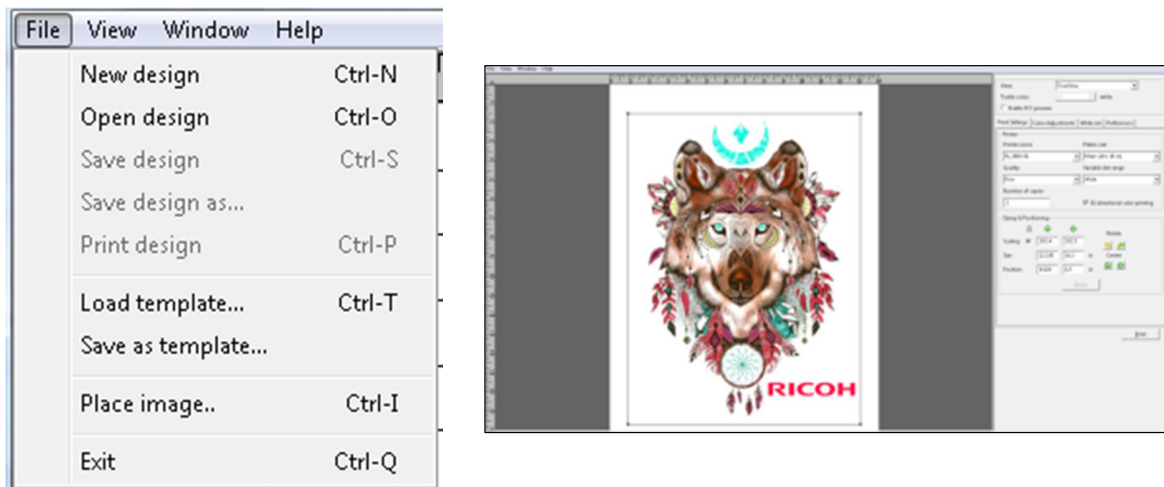

Place Image

Loading Graphic into RIP

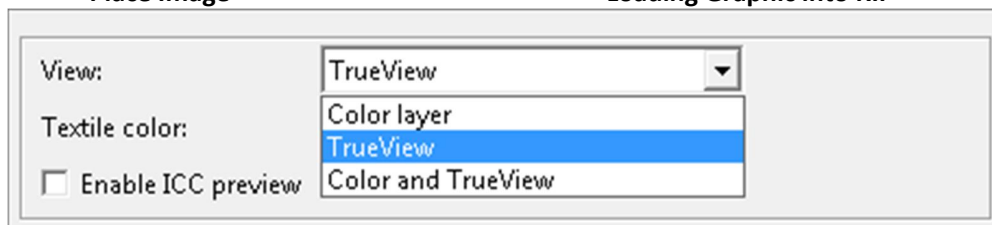

View Menu

- At the right top of the settings you will see a drop down select for View. When printing a light garment, you will see 3 choices.

Color Layer: Displays the CMYK Colors that will appear on your substrate/garment

True View: “What you see is what you get” (WYSIWG), Displays how the final result should appear when print is completed.

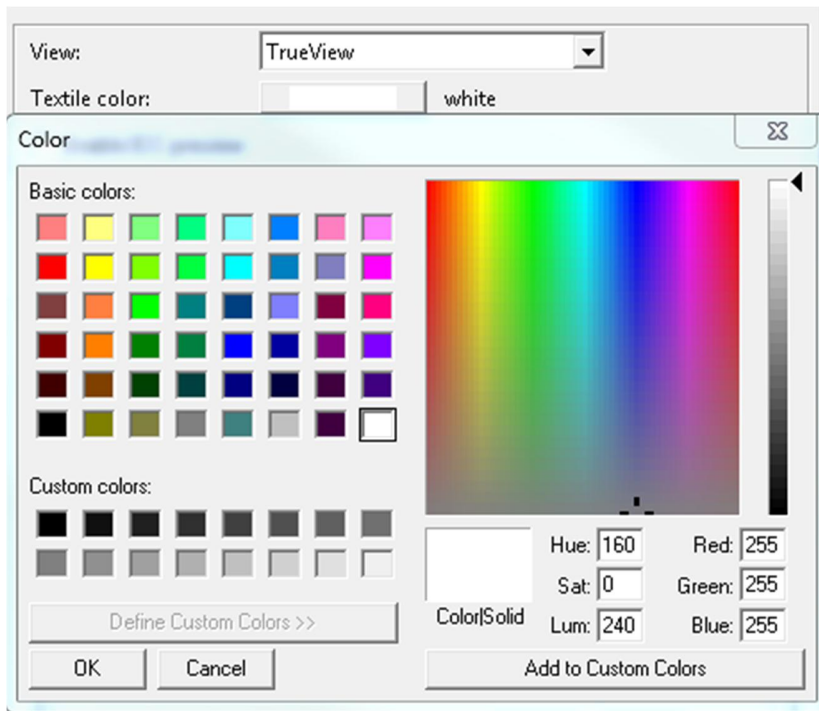

- **Textile Color Selection:** Change the textile color to determine if your image requires a white under base. Light color garment examples are; Yellow, Pink, Light Blue etc. By changing the textile color your preview will change (shown below)

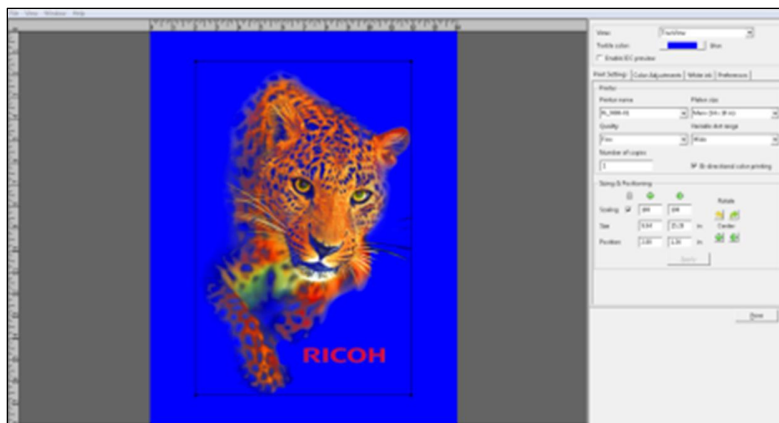



- **Color and True View:** Displays side by side preview of both the CMYK color Layer and the final result

The second tab will be the open default view; this tab is called Print Settings. The first option you will encounter in the Print Settings Tab is the Printer Name drop-down. Here you can select where the print job will be sent when the print button is pressed. If ETHERNET is selected in the Printer Name drop-down then when the print button is pressed the job will RIP to the Ri 1000 printer that is currently connected to the computer through the ethernet cable. Printing this way is similar to using any standard desktop printer. If Ri 1000 File is selected, then the AnaRIP software will process the file to destination of your choice. You can RIP your files to your computer's desktop or to a folder of your choice and print them later, or you can RIP your files to a USB Flash Drive, which can then be plugged into the printers control panel.

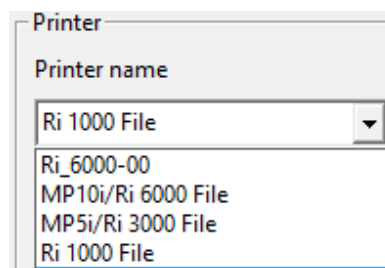

Select Printer

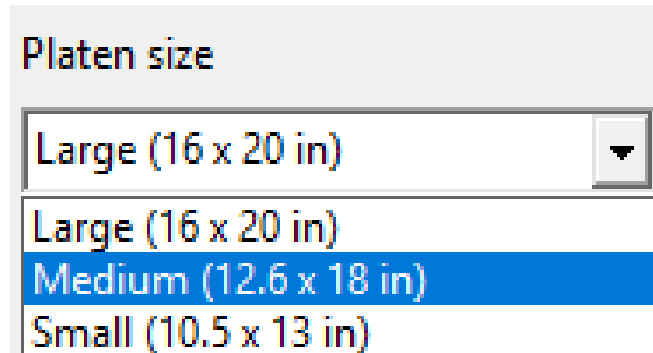

- **Platen Size:** By default, when the Ri 1000 printer is selected, the Platen size will also default to MEDIUM 12.6 X 18 in. This is the Platen that will be included with your printer
LARGE 16 x 20 in and SMALL 10.5 x 13 in are optional Platens that can be purchased as an accessory.

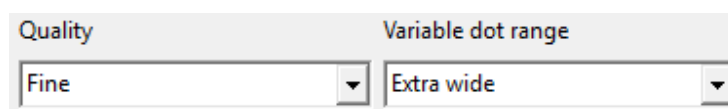

- **Quality and Variable Dot Range:** When the Ri 1000 is selected the default print setting will BE set to a **fine QUALITY** and an **extra wide VARIABLE DOT RANGE**
- The **Quality** has two other options described below:
 - **SPEED:** Used to test substrates not recommended for final print or solid color blocks
- The **Variable Dot Range** has two other options described below:
 - **Narrow:** Must be used with UNI-DIRECTIONAL enabled, provided a smaller droplet size resulting in less saturation, ideal for thinner substrates, like polyester, normally should not be used as prints will be faint ** Disabled in AnaRip with this dot size**
 - **Wide:** Must be used with UNI-DIRECTIONAL enabled, provides a slightly larger droplet size than **Narrow** ** Disabled in AnaRip with this dot size**
 - **Extra Wide: This is the default that should be used for most prints**

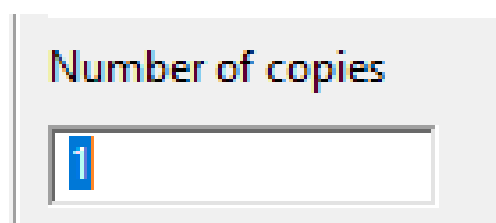

- **Number of Copies** is where you enter the amount of prints you would like to send to the printer.
This feature is disabled for the Ri 1000 and is grayed out

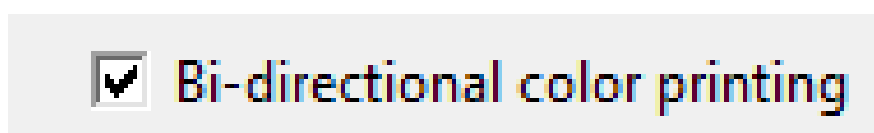

- **Bi-directional Color Printing:** By default, this option will be enabled. This will allow the printer to print in both directions (left to right, right to left) allowing for maximum productivity and speed.
 - By unchecking the **Bi-directional color printing** option, you can achieve a much more accurate CMYK Print but it will sacrifice the speed/productivity as you will be printing **ONLY** from right to left.

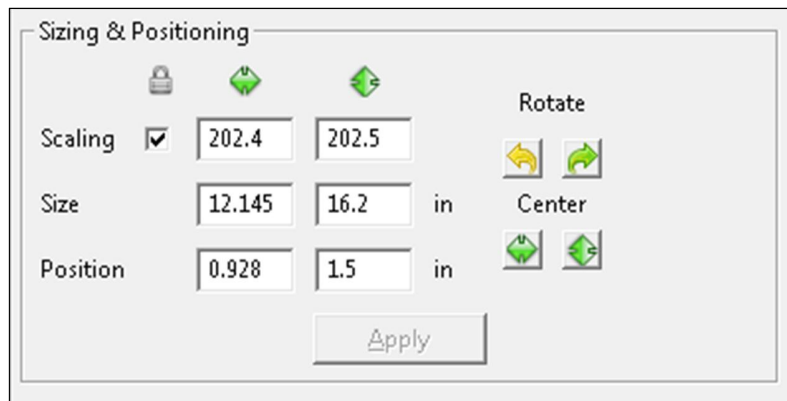

Scaling will adjust your image Horizontal and Vertical size by a percentage. If the lock is clicked on, the aspect ratio of the image will stay the same so the image will not become distorted in size.

Size will affect the images size in specific measurements horizontally and vertically. If the lock is clicked on the aspect ratio or the image will stay the same so the image will not become distorted in size. You can also change the image print size by clicking on and dragging on the image frame in the preview area. If you drag the corners the aspect ratio will be maintained. If you drag the tops or sides you will stretch or compress your image.

Position is for placement of your graphic into a specific area of the Print Table. This will be used to move a graphic higher or lower vertically or left to right horizontally. The image can also be moved by dragging the image with your mouse in the preview screen. If you want to center your image on the print table horizontally or vertically, the Center button for each can be used. Using the Rotate buttons will rotate your image in 90 degree increments left or right.

Input Color Profile

An ICC profile contains information for converting an image between a device-specific color space and a device-independent color space (Photoshop).

The input ICC profile translates color data created on a device (such as a digital camera) into the PCS, profile connection space. The RIP uses the output ICC Ink Set Profile (PowerBright or PowerBright Plus) to convert from the PCS into the native color space of the Ri 1000.

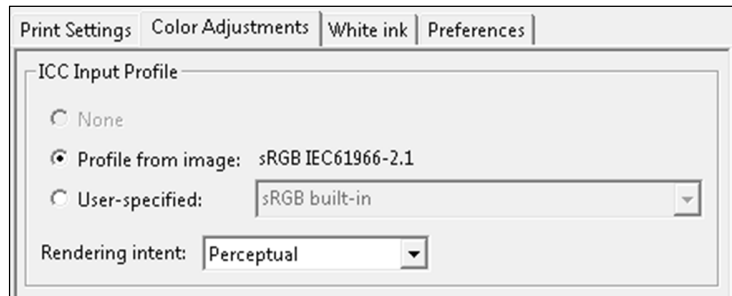

- **ICC Input Profile:** Images created in Photoshop most often contain a built a profile for the specific color space the image was designed in. The rip allows you to change use a different ICC profile instead of the ICC profile that is part of the image file. ** It is recommended to use **Profile from image** in most print cases (if available)

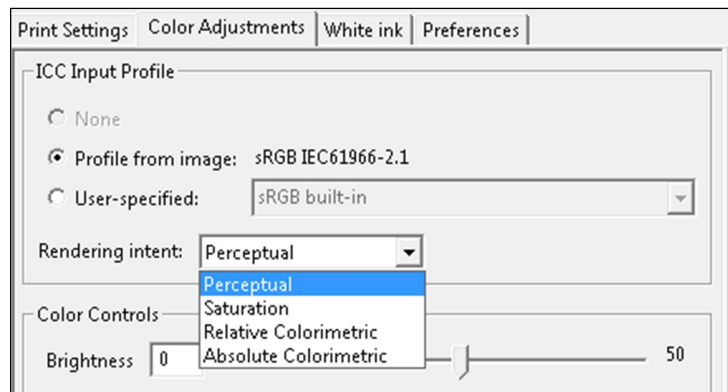

- **Rendering Intent:** specifies the rendering intent that this step should associate with the job. Rendering intents inform the printer what action to take when a print job includes colors that lie outside the color range of the printer.
 - **Perceptual** (default): The printer adjusts all the colors in the image so they are all in the color range of the printer and maintain their color relationships to each other.
 - **Saturation:** The printer substitutes the nearest color that it can print for out-of-range colors and adjusts in-range colors to make them more vivid.
 - **Relative Colorimetric:** The printer substitutes the nearest color that it can print for out-of-range colors; in-range colors are not adjusted.
 - **Absolute Colorimetric:** The printer substitutes the nearest color that it can print for out-of-range colors, and then all colors are adjusted based on the white point of the media.

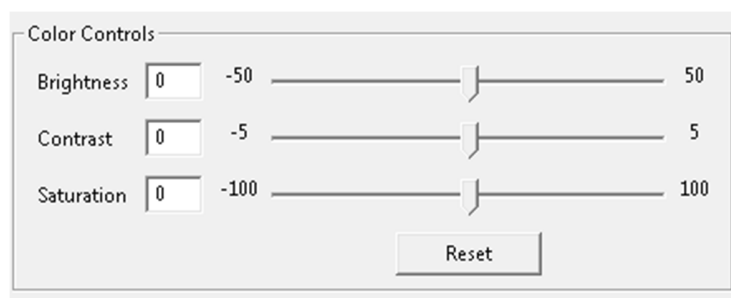

- **Color Controls:** Allows you to adjust the graphics Brightness, Contrast and Saturation. The Color Controls effect will be visible in the preview screen when they are adjusted.

Brightness Adjustment



Brightness Up



Brightness Down

Contrast Adjustment



Contrast Up

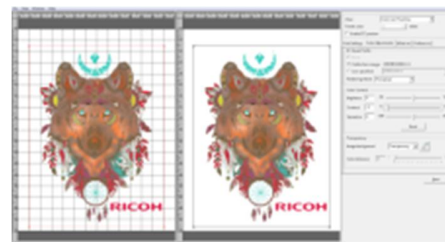

Contrast Down

Saturation Adjustment



Saturation Up



Saturation Down

4.3 AnaRIP Advanced features

Manage Ink Set Profiles

By default, the printer is set with Ri 1000 Type G1 ink set –

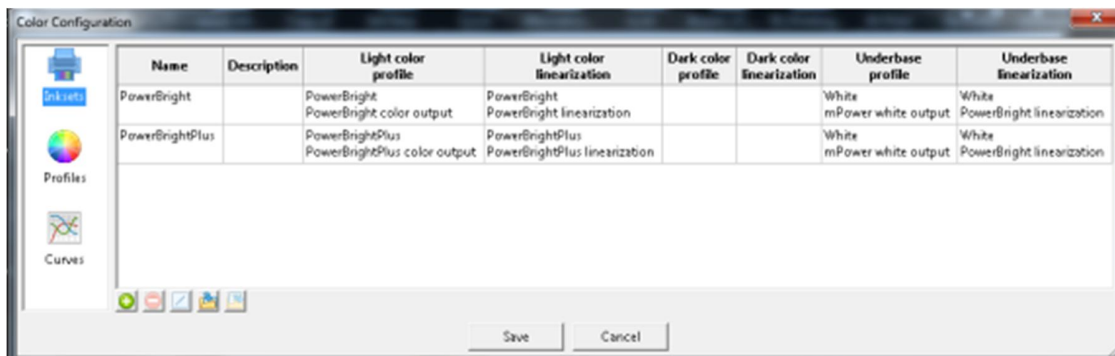

Ink Set Profile Management.

To add an additional Ink Set, select the Plus sign and proceed to fill in the ink set editor.

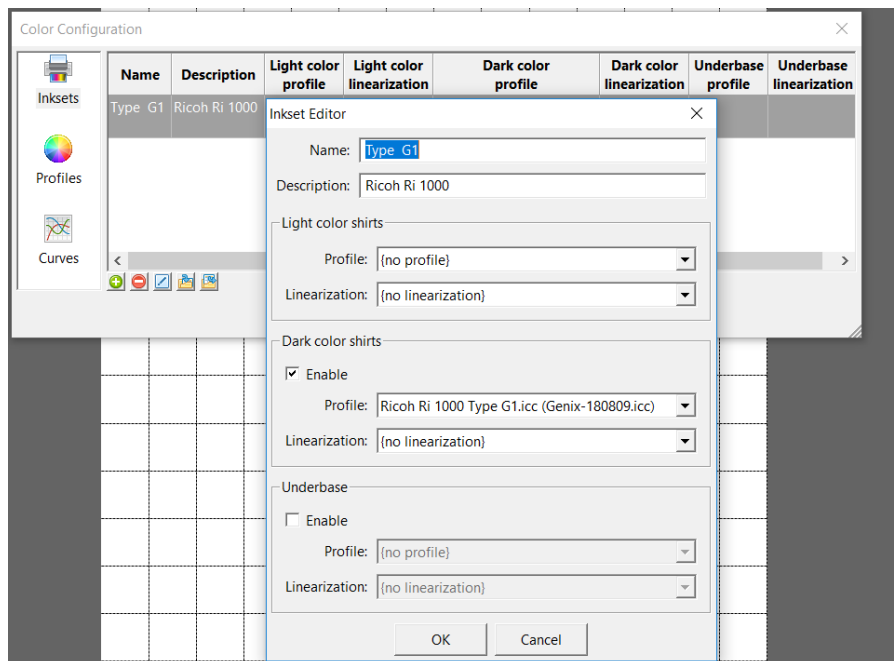

Ink Set Editor

Manage Color Profiles

To add a new ICC color profile, click on the plus icon and locate the location of the file on the PC. Profiles can be created through the use of X-Rite IProfiler or other similar products.

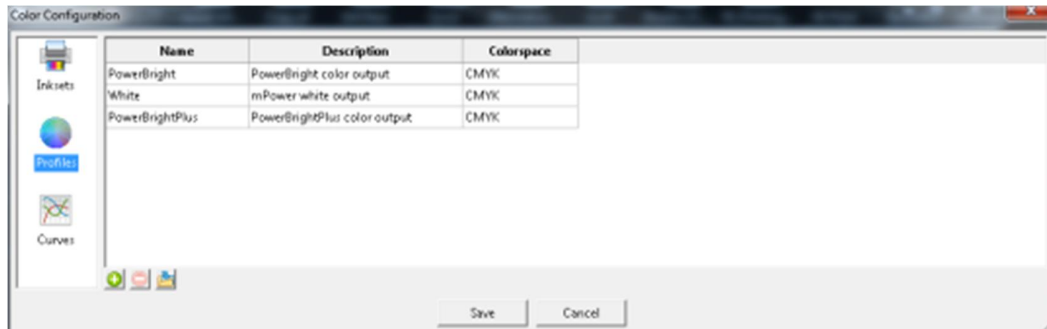

ICC Color Profiles. Manage Color Linearization Curves

To add a new linearization curve, click on the plus icon and locate the location of the file on the PC. AnaRIP comes with a curve editor preinstalled. The curve editor can be located in the Start Menu of the PC. ** Note: The default profiles do not require linearization curves**

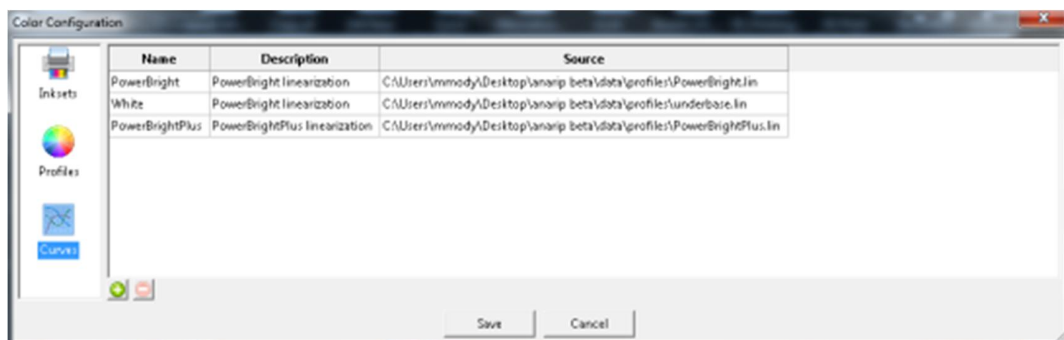

Color Curves

Curve Editor

The curve editor allows the user to develop their own color curves which can be imported into the rip.

Curve editor

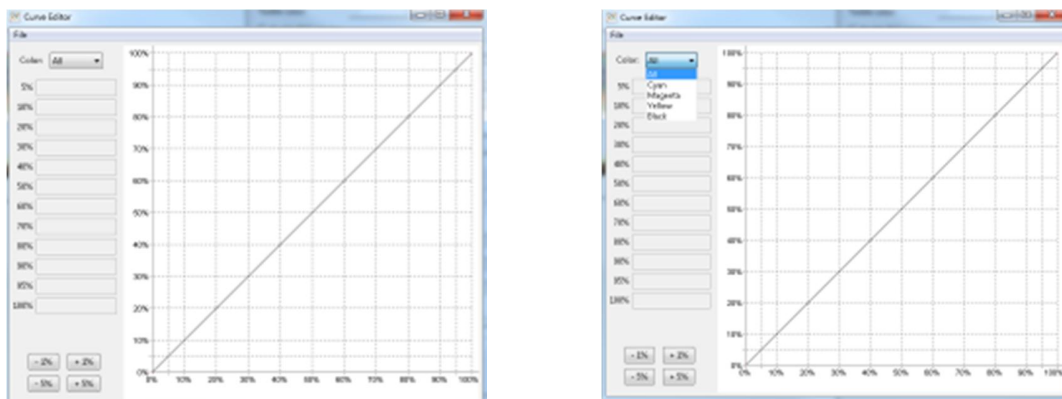

Remember to press the Apply button so the changes are saved for the next print job. When you Enable ICC preview within the AnaRIP, this is modifying the current screen settings on your computer to display our color profile used for the output of our AnaRIP color profile. This function will not change the output of the printer. It will help you see the true color profile rather than the preselected color profile on your monitor. This feature will help achieve color accuracy once you start your production. You can find this feature selected below in the picture.



Selecting ICC Preview

4.4 Removing Garments from the Print Table

After printing has completed, remove the hoop from the table. Do not touch the image as the ink is still wet at this point. Remove the garment from the table being sure that the printed image is facing you when it is removed. Do not let the shirt fold or touch itself as this could cause ink transfer to other parts of the garment. Take the garment to your heat press or conveyer dryer fix the ink to the garment.

CAUTION

- When removing the fabric, be careful so that your hand or any other part of your body does not come in contact with ink. If your skin comes in contact with ink, wash the affected area thoroughly with soap and water. If your clothing comes into contact with ink, wash the stained area with cold water.

4.5 Set the Image with Heat

User's Notes

- For information about how to use the heat press device, see the manual.

In order to cure the ink so that your images will be color-fast when washing, it is necessary to heat treat the image so that the image bonds with the garment.

- If you are using a heat press place the garment on the heat press platen with the printed side up. Pull by the edges to ensure proper placement and that it is flat on the heat press, minding not to touch the wet ink. Cover the garment with a sheet of SoftTouch heat press paper, for Ricoh authorized ink. Close the press and heat the printed garment for 100 seconds at 356°F or 180°C. The pressure applied by the heat press when close should be in the light to medium range. When the time is completed open the heat press and remove the heat press paper immediately. SoftTouch heat press paper can be reused several times.
- Instead of SoftTouch, a Teflon sheet or Kraft Paper Cover Sheet can be used. When reusing the SoftTouch Paper, make sure there are no wrinkles as these will transfer to the garment. If this is the case use a new sheet. The printed garment is now completed. If you are also printing dark shirt images you need to reduce the heat press temperature and increase the time. Settings for dark garments of 330°F or 165°C for 90 seconds will also work for light garments.
- If you are using a textile oven or conveyor dryer, please test the temperature of the printed image when it exits the dryer to assure that it has reached 330°F or 165°C. Also, please do a wash test of your first attempts to be sure that the inks have cured properly and wash ability has been attained.

Ricoh Authorized Ink	Temperature	Time
Light Shirt with Heat Press	356°F or 180°C	100 seconds
Light Shirt with Conveyer Dryer	Printed image must reach 330°F or 165°C	Varies

Heat Curing Temperature and Time Variations for Light Garments

5 Using AnaRip to Print Dark Garments

Pretreating Substrates (light and dark)

CAUTION

- When swallowing or inhaling ink, cleaning solution or pretreatment liquid, or when getting them in the eye, follow the guidance in the appropriate safety data sheet (SDS). Download the SDS from the AnaJet website at <http://anajet.com/technical-documentation>

CAUTION

- Place ink, cleaning solution, and pretreatment liquid in a cool, well-ventilated place out of the reach of children.

- Keep waste ink, containers for ink, cleaning solution and pretreatment liquid, and components that have been in contact with ink out of the reach of children.

- When handling ink, cleaning solution or pretreatment liquid, avoid getting anything on your clothing. If you do, wash the stained area with cold water.

Pre-treatment Liquid is to be used with care. Do not let it contact your eyes. Do not breathe in the vapor or mist. Thoroughly wash your hands after handling it. If your clothing gets contaminated, wash it before reuse. If an accident happens please follow the Caution and First Aid instructions on the Pre-treatment Liquid bottle label.

Due to the corrosive nature of the pre-treatment solution, we recommend that all users apply pre-treatment using gloves and a dust mask. Follow the instructions on the label. For dark substrate printing, the most critical process is proper application of Pre-treatment Solution onto the substrates. Spotty or improper application of the Pre-treatment or improper drying will result in white ink not bonding properly with the substrate fabric. This in turn will cause poor image quality and premature wash out of the image.

For additional information, please refer to the SDS sheets located on the website at <http://anajet.com/technical-documentation>

[Pre- treatment Application Procedure]

- A well-ventilated room. Good ventilation is essential for worker comfort and health. Application of Pre- treatment Liquid outdoors is not recommended on windy days as it can cause uneven application. It is recommended that a room away from the printer be dedicated to the application of pre-treatment so that the spray will not affect your printer.
- Our recommended process for applying the Pre-treatment Liquid is to use a High-Volume Low Pressure (HVLP) spray gun. These spray guns are commonly used for applying paints and are available from paint supply stores or home improvement stores. The Wagner Control Spray Gun, available for US customers **ONLY** and Campbell Hausfeld Paint Sprayer, found in local hardware stores are both good choices.



- Fill the sprayer reservoir with the mixture.
- Lay the substrate on a flat spray table. Make the substrate even and flat.
- Apply the pre-treatment mix with the sprayer adequately and an even amount, achieving an even wet sheen. Remember you only need to apply the pre-treatment to the areas that will be printed on.
- Squeegee the pretreatment in one direction to help spread the pre-treatment evenly after spraying. This also flattens any fabric fibers that may have risen due to the application of the wet pre-treatment.
- Dry the substrate. You can achieve an excellent result by letting the substrates air dry or you can use a heat press in the hover position (This means the heat press is not closed but has a ½-inch to 1-inch gap to allow the steam to escape) or a heat tunnel. Do not dry your substrates in a tumble dryer. These dryers are full of lint and since the pre-treatment is wet and somewhat sticky you will end up with lint stuck to the pre-treatment.
- Once the substrate is dry to the touch, its able to be printed on. If you plan on storing the substrates for later use, be sure that they are completely dry beforehand to prevent mildew.
- When first attempting the pre-treatment process test with a few shirts to determine how much to spray. Too much pre-treatment can leave dark areas on the substrates. Too little pre-treatment can

make the prints look dull. **The performance of white ink is highly dependent on proper application of pre-treatment.**

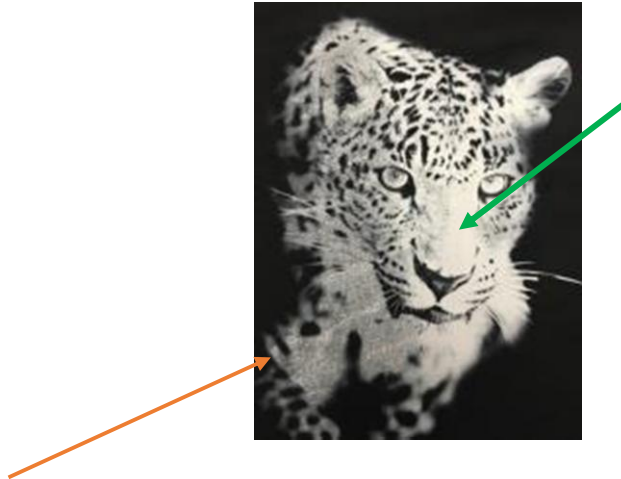

Poor Pre-Treatment Can Be Seen on the Left Side of this Image and is shown to be muddled, gray and not as solid as the nose of the leopard (green arrow)

- Check the Enable White Underbase box to use white underbase layer in the print

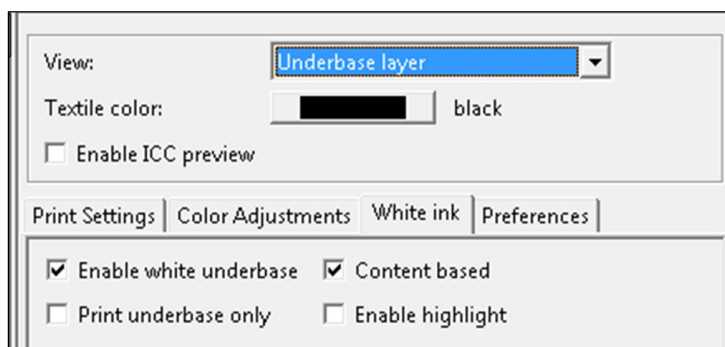

5.1 Underbase

When you enable white ink following things will happen. First the background will switch to black, unless you have a different Preview Color selected. Select the Underbase layer in the view section where True View is displayed by default. ** Most cases can use **Fine Extra Wide** for underbase , **DraftSpeed** should be used to check print position, **Super Fine** should be used for special applications that require a lot of ink**

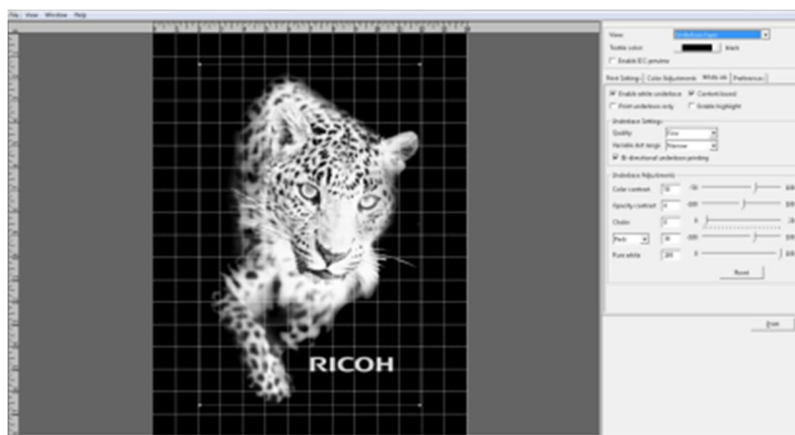

View After Enabling White Ink

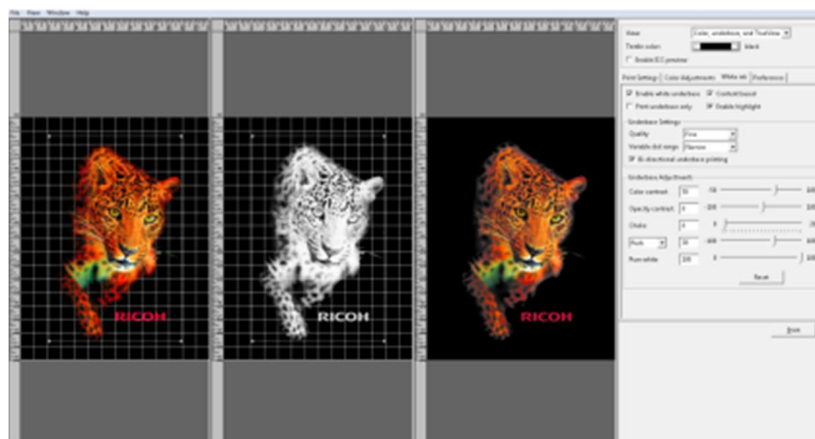

5.2 Underbase Tab Settings

By default:

- Content based checkbox will be checked will only use white ink where required in the image (grayscale effect)

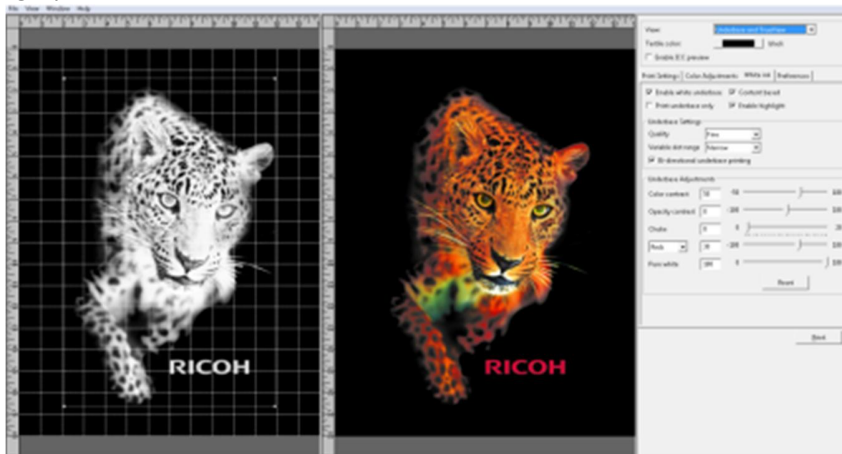

- Quality is set to Fine
- The Variable Dot Range will be set to Extra Wide.
 - ❖ ***The Bi-directional Underbase printing checkbox will be checked for optimum speed when printing the Underbase.***

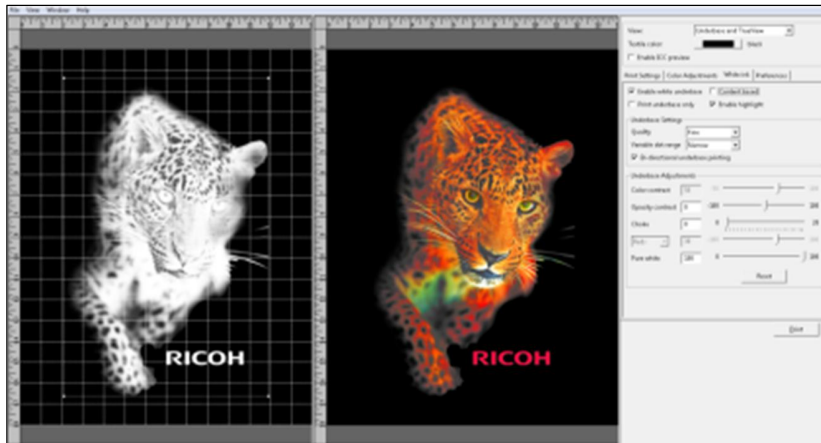



❖ **Content Based Unchecked**

This feature will use print an underbase for all colors being used in the color pass.

- *Note: when using the content based unchecked, it is highly recommended to also add a color layer wait time/dry time in between the white underbase and the color layer*

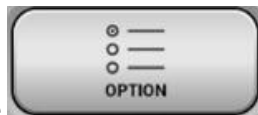
- In the printer  tab



- Tap the  icon



- Tap  icon

- Insert a numeric value in seconds based on how saturated the white under base is



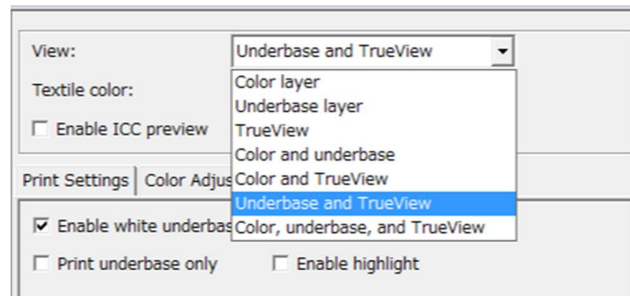
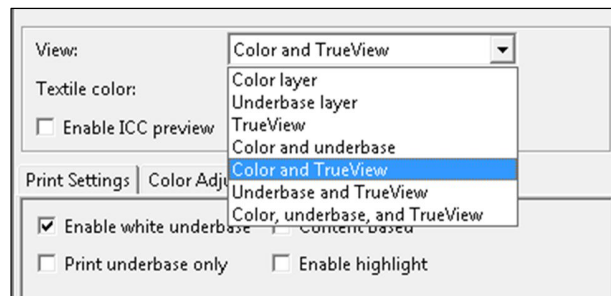

White Ink Enabled > View > Menu Options

Using the View option, you can monitor how your adjustments to the Underbase will affect your printing results by selecting the Underbase and TrueView option (The Underbase and TrueView images should now be visible in the preview screen). There are five ways to adjust your white Underbase, Color Contrast, Opacity Contrast, Choke, Individual Color Adjustments and Pure White. Note that some of the functions are disabled when Content Based is not checked.

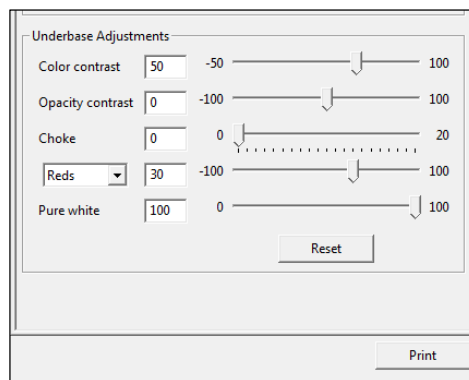

5.3 Underbase Adjustments

Color Contrast will affect the amount of white used in the image and can be adjusted with the Color Contrast slider bar. Moving the Brightness slider bar all the way to the right to 100 will give you a more solid white ink Underbase and in turn brighter colors. Moving the slider bar left towards -100 will create more of a grey scale white Underbase and less vivid colors

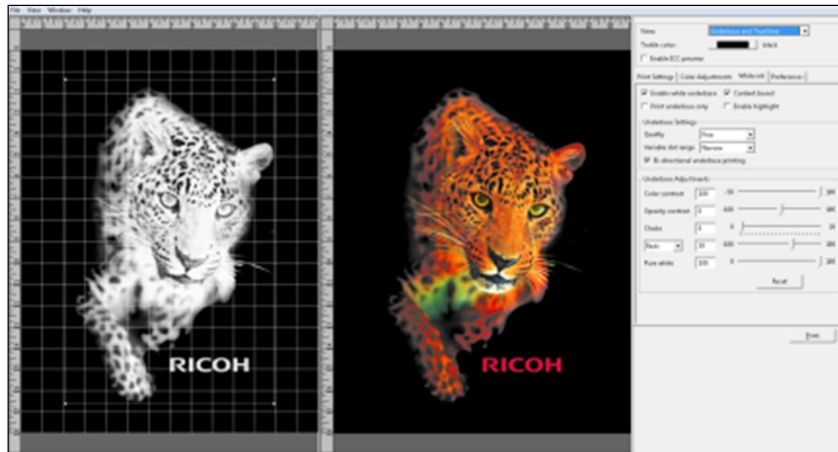

Color Contrast Slider Up

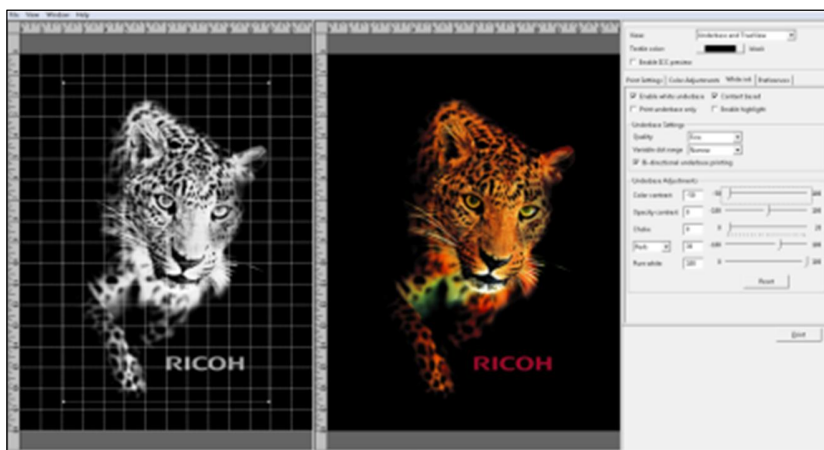

Color Contrast Slider Down

Opacity Contrast is only active when your image has a soft or semi-transparent edge or the image has semi-transparent colors in it. Moving the slider bar to the left will reduce the amount of white Underbase beneath these areas to help create a smoother blend.

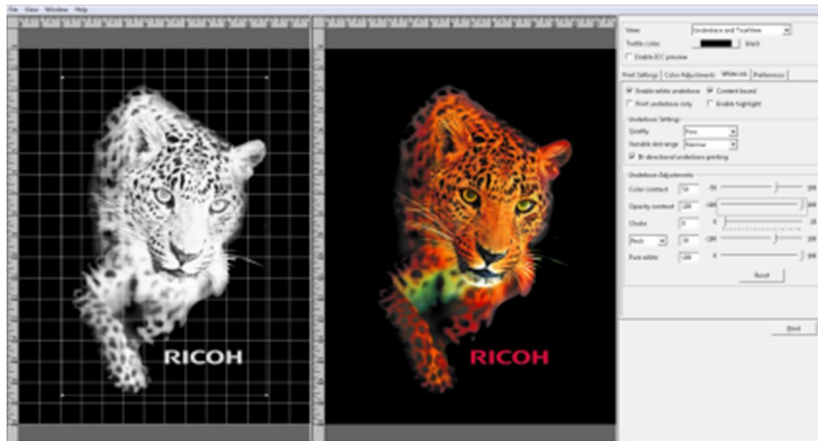

Opacity Contrast Up

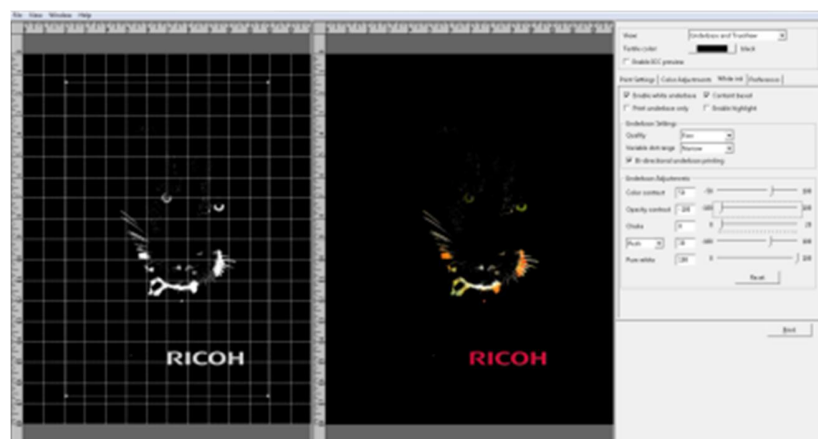

Opacity Contrast Down

5.4 Choke

Combats the phenomena that when printing the White ink Underbase onto a garment the garment will expand and swell. This is the same for any type of garment printing including screen printing. The Choke setting slightly reduces the outside dimensions of the Underbase so that white ink does not appear outside the prints edges of the final color pass. Under the Choke setting use the default value of 2 on a full size print, you will lower this if your image is small. If you see any white around the edges of your final print you will want to increase the choke value.



Choke Needed

If you are printing an image that is only white you will need to set the Choke to 0 to prevent parts from dropping out completely.



Choke Increased to 2



Choke at 0

Individual Color Adjustments By selecting a color from this drop-down menu you are able to increase or decrease the amount of white ink Underbase that will print under that color. This will help you bump up or bring down certain colors in your final print. You can multiple different colors using this setting.

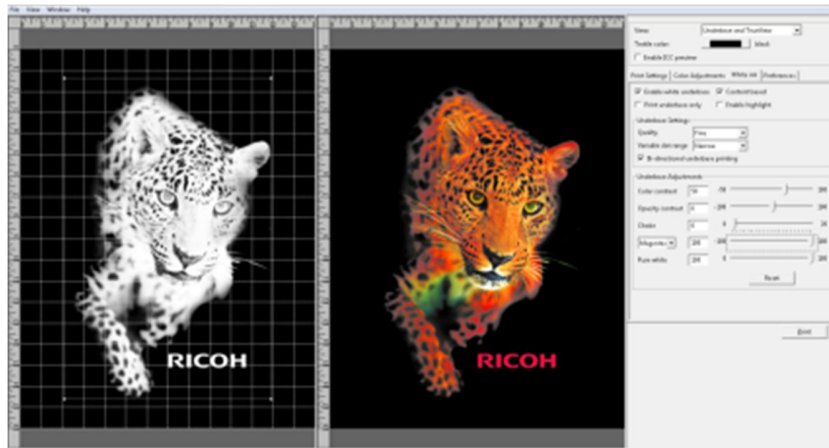

Color Adjusted Up

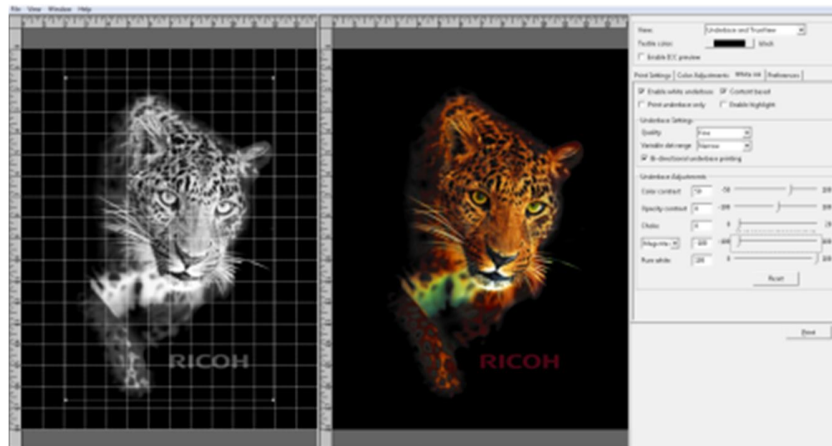

Color Adjusted Down

5.5 Pure White

Is set at 100 by default to print the whitest ink in the pure white areas of your image. If desired this can be lowered here.

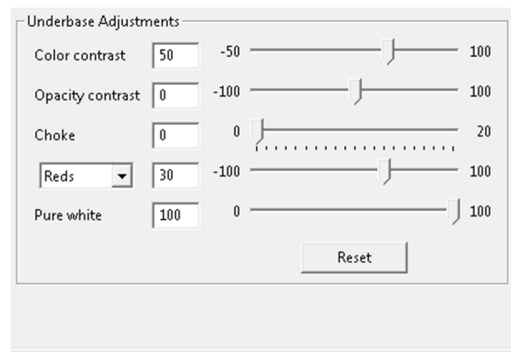

Pure White Adjustment

Remember you can still further adjust your image by changing the settings on the Color Adjustments Tab. Also located on that tab is the Transparency window that will let you remove a color range from your image to create a transparency. *This feature is limited so you may achieve better results using your image editing software.*

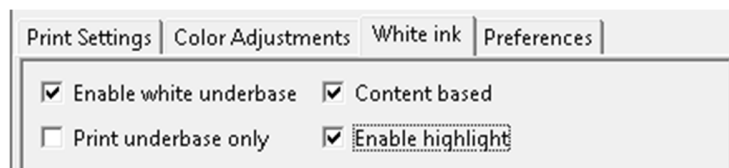

Enable White Highlight

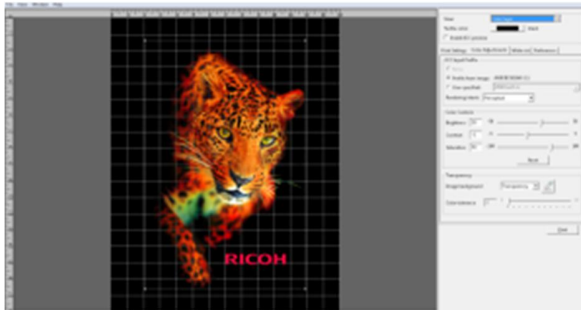

White Highlight Enabled

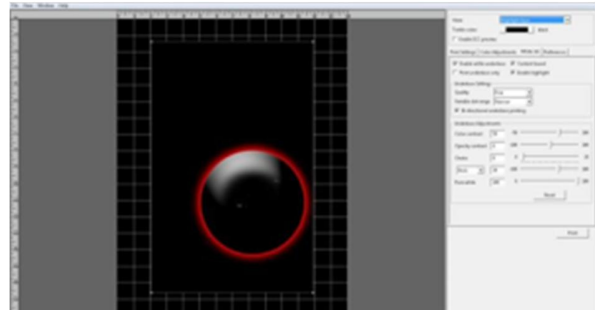

Highlight Layer View

- White Highlight allows for a second layer of pure white to be printed during the color layer, allowing for a brighter white. If using white highlight, make sure there is dead pixel space between any large amounts of pure white and any CMYK color as it may cause white ink to mix the color at the edge.
- To remove all of a specific color range, select Select Color. Then click the color you want to remove from your image. The selected color will be removed from the entire image. You can increase the range of the color removed by adjusting the Color Tolerance slider.

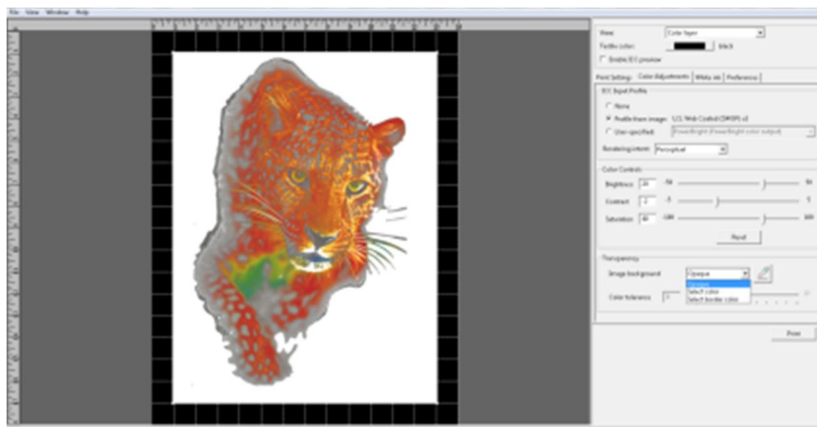

Select Color to be Removed

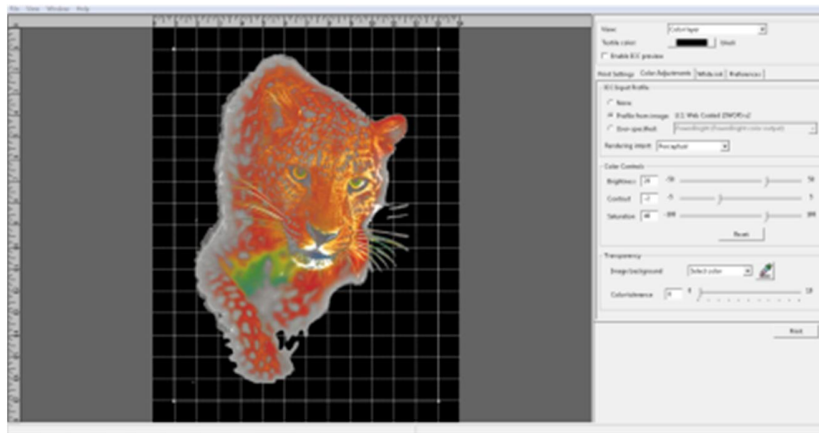

5.6 Select Border Color to be Removed

You can also select to remove a Border color. This removes a contiguous color up to when it changes to another color. Please note that better results will be achieved by using your image editing software to create transparencies.

Once you have completed your settings and adjustments you can now send your image to the printer by pressing Print or save the graphic to your computer or an USB drive by selecting Print to file.

The Printer will first print the White layer. Once completed, the printer will print the Color Pass. Since the white Underbase layer may not be dry enough to receive the color layer, there is an adjustment on the printer's options menu to set a wait color layer wait time before the color layer is printed. By default, it is set to 0.

5.7 Set the Image with Heat Treatment

User's Notes

- For information about how to use the heat press device, see the manual.

In order to cure the ink so that your images will be color-fast when washing, it is necessary to heat treat the image so that the image bonds with the garment.

- Place the garment in your heat curing machine image side up set to the correct settings found below.
- If you are using a heat press bring the top down to within 1 inch of being closed and hover the heat press over the image for 15 seconds. This hovering step prevents the mixing of the white and color layers. Both layers are still wet and need to set up a little before applying pressure. This step is needed to produce the best final result when using a heat press.
- Re-open the heat press and cover the image with SoftTouch heat press paper. Instead of SoftTouch, a Teflon sheet or a Kraft Paper Cover Sheet can be used. If you use a Teflon pad it will leave a semi-glossy look to the prints.
- Close the heat press and let the ink cure for the prescribed time. (Figure 7.6-1)
- When the time is completed open the heat press, remove the heat press paper and your printed garment is complete.
- If you are using a textile oven or conveyor dryer, please test the temperature of the printed image when it exits the dryer to assure that it has reached 330°F or 165°C. Also, please do a wash test of your first attempts to be sure that the inks have cured properly, and wash ability has been attained.

Ricoh Authorized Ink	Temperature	Time
Dark Shirt with Heat Press	330°F or 165°C	90 seconds
Dark Shirt with Conveyor Dryer	Printed image must reach 330°F or 165°C	Varies

Heat Curing Temperature and Time Variations for Dark Garments

6 Maintenance

Your printer performs automatic maintenance routines based on time and use. Because of this your machine is almost always ready to print when you need it. However, it is also a best practice to perform a nozzle check prior to printing.

Below is a list of maintenance procedures and frequency for those that are time based.

Period	Perform
Every 1 hour	White ink circulation
Every 3 hours	White channel cleaning
Every 12 hours	All channel cleaning Alarm agitating white cartridge
Every 7days	Alarm manual cleaning

ATTENTION! Auto maintenance will be not be perform if the following conditions occur. Failure to perform Auto maintenance can result in a clogged print head.

Printer is powered off. (Always keep the printer powered on)

Ink cartridge is missing or reading 0%

CR encoder error

Any Service call message (see trouble shooting guide)

Front cover is open

The ink bay has been opened for maintenance

If the auto maintenance is not being performed, then the print heads can be clogged.

6.1. Nozzle check

- Make sure to perform a nozzle check before printing. If there is a nozzle clogged, perform head cleaning until the clog is removed and reflected on the nozzle check
- Nozzle checks must be performed on transparent overhead projector film
- If any part of the transparent overhead projector film is curled, tape it down to avoid an obstruction detection
- The MEDIUM sized platen (included with the printer, optional small and large tables available) must be used to perform the nozzle check

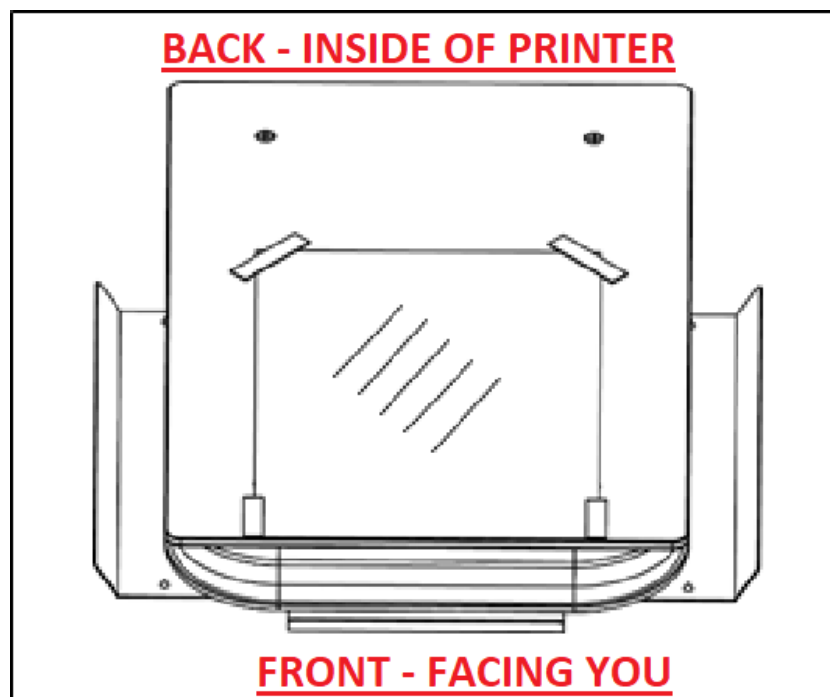

- Press SET to move the table to the print position

- Press  button located in the  tab

- Check the results of the printed nozzle check pattern

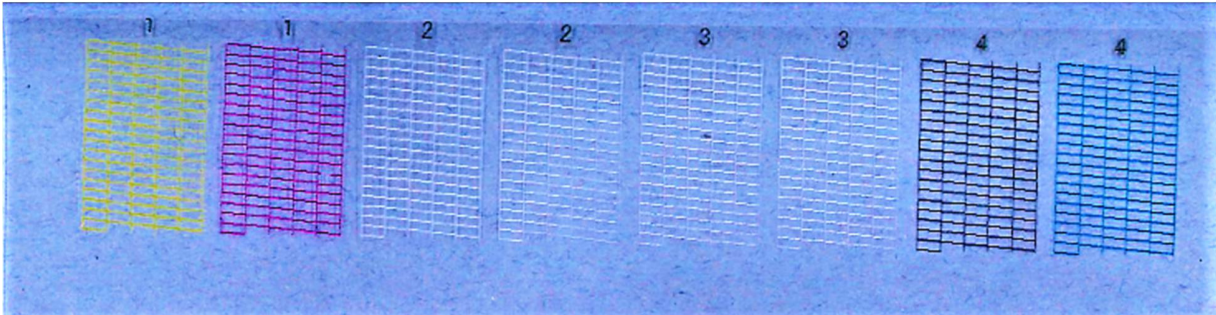

In your nozzle check please check for the following and take the appropriate steps:

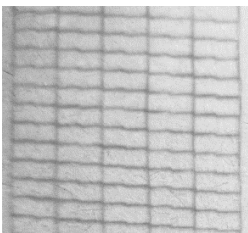

Perfect Nozzle Check

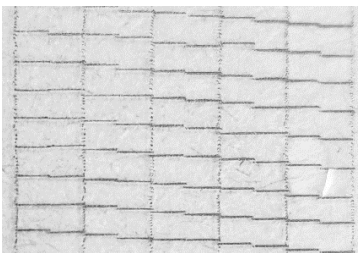

Nozzle Deflection: When horizontal lines are uneven ---__



Clogged Nozzle: When the horizontal lines have small or minor gaps -- --

6.2. Automatic Head Cleaning



- Press AUTO HEAD CLEAN button to perform automatic head cleaning.

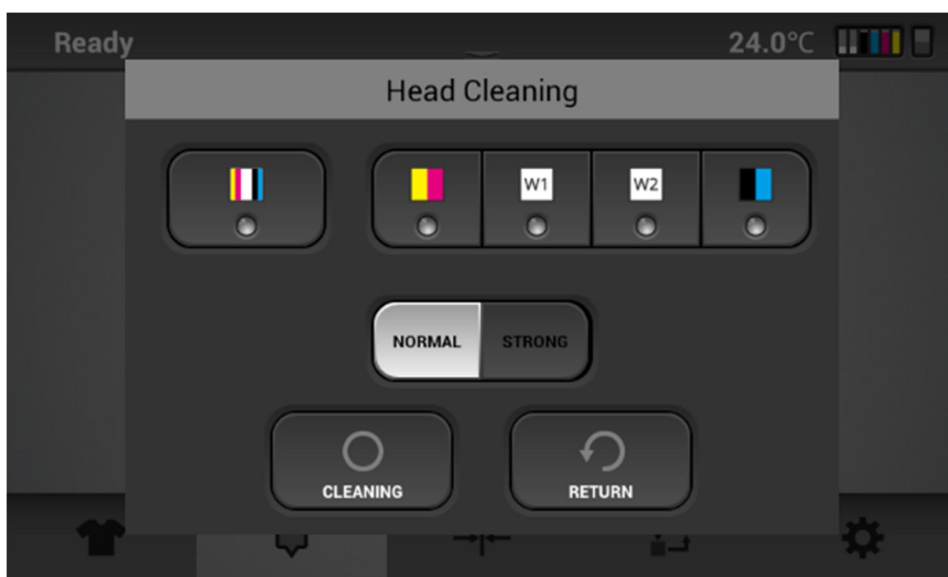

- In this dialogue box, choose the channel to clean using NORMAL for small or minor missing nozzles
- Use STRONG when there are large missing nozzles in the nozzle check
 - ❖ *If missing nozzles persist after performing the normal or strong cleans, let the printer sit idle overnight (6+hrs)*



- After performing the normal cleaning, nozzle condition is not recovered proceed to using the STONG clean option

ATTENTION
STRONG head cleans will use more ink than the NORMAL cleans, use only as needed

White Clean Freq.

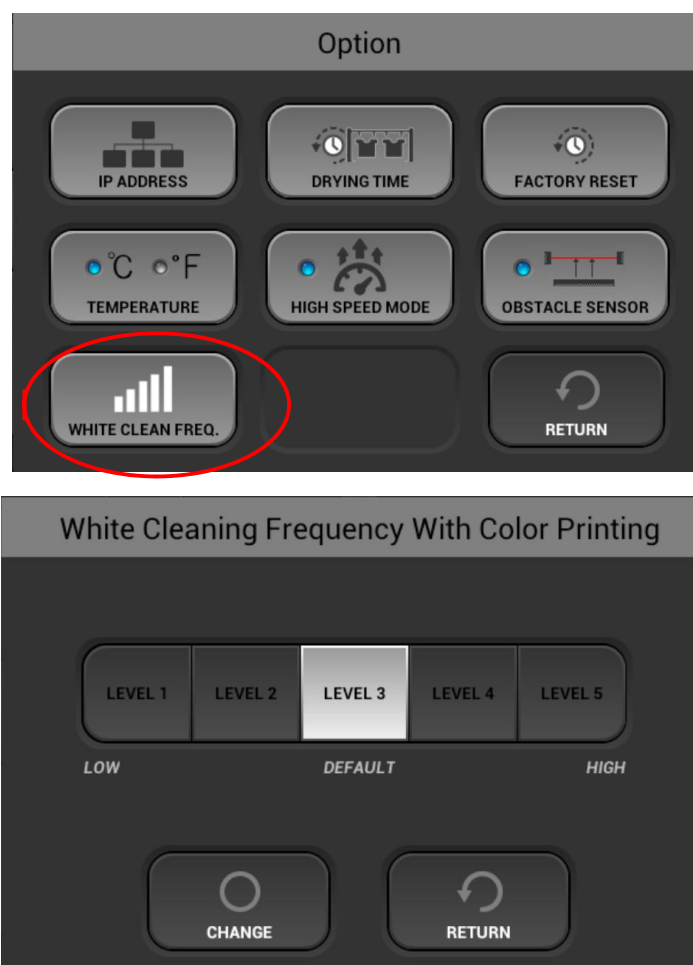

White Clean Frequency

- This option determines how often a automatic white head clean will occur while printing. Below is a description of the clean levels.
(LOW) L1 After 20 CMYK only Prints or after approximately 10 (varies depending on size) CMYK and White prints a white head Clean will occur
L2 After 15 CMYK Prints or 7 to 8 CMYK and white a white head clean will occur
(Default)L3 After 10 CMYK Prints or 5 CMYK and White a white head clean will occur.
L4 After 5 CMYK Prints or 2 to 3 CMYK and White prints a white head clean will occur.
(HIGH) L5 After 1 CMYK or CMYK and white print a white head clean will occur.

6.3 Manual Head Cleaning

- If the Nozzle status is not recovered with automatic head cleanings (NORMAL or STRONG), then you must clean the head manually.



- Pressing the MANUAL HEAD CLEAN button will release the print head and moves it to the center of guide rail
- Open the cover of the printer to allow for better visibility of the print head carriage
- Using a large cleaning applicator, wipe the printheads in one direction, from back to front. DO NOT SCRUB the printhead. DO NOT reuse the same large cleaning applicator for a new printhead



- ❖ To remove stubborn clogged nozzles of the print-head gently wipe the nozzle surface of print-head using swab with RICOH cleaning solution in one direction. DO NOT reuse the same large cleaning applicator for each printhead

- clean the gaskets and wiper mechanism

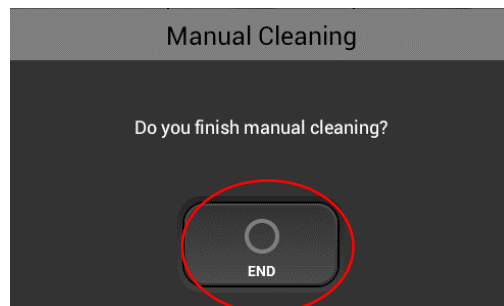
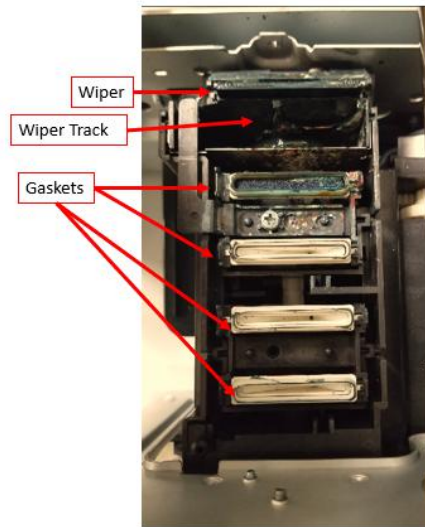

- If the manual cleaning is finished, press [END] button to return to the previous menu and to return the carriage to its home position

6.4 Agitating White Cartridge

The printer will prompt you every 12 hrs with the following message:

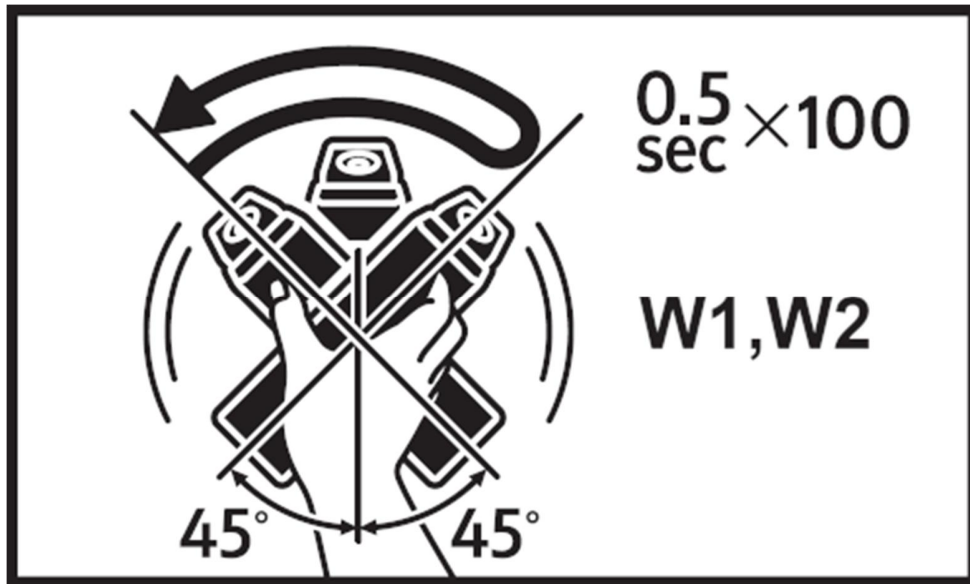

CAUTION:

DO NOT hit or drop it when stirring. As it may cause injury, cartridge damage, ink leakage.

DO NOT excessively agitate/swing. as it may cause ink leakage.

MUST AGITATE/SWING as instructed. Other methods may cause ink leakage.

- Hold the cartridge horizontally as shown in Fig. 1.
- Shake the cartridge in the direction of rotation left and right as shown in Figure 1. of the arrow in Fig. 1.
- Make the ink cartridge reciprocate for 50 seconds in the direction of rotation of the arrow in Figure 1 in the left and right directions.
- Shake speed is the speed to make two reciprocations per second.

Fig. 1



Warning
DO NOT shake cartridge too fast or hardly.

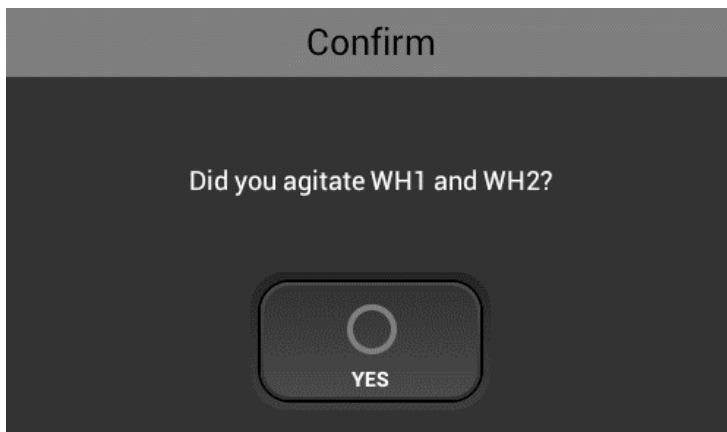

- After agitating cartridges, insert the cartridges

6.5. Circulation

- This printer has the function of white ink circulation that moves the white ink in the system from the ink bay to the printhead and back. This is used to avoid the white ink settling within the lines and provides quality white ink prints.

6.6. Empty the Waste Ink Bottle

- Once a certain amount of ink has been used, the following message is displayed on the touch panel.
- Put the waste ink from the waste ink bottle into a container to discharge it.
- You can check the amount of waste ink on the [Status Panel] and reset the waste ink counter.

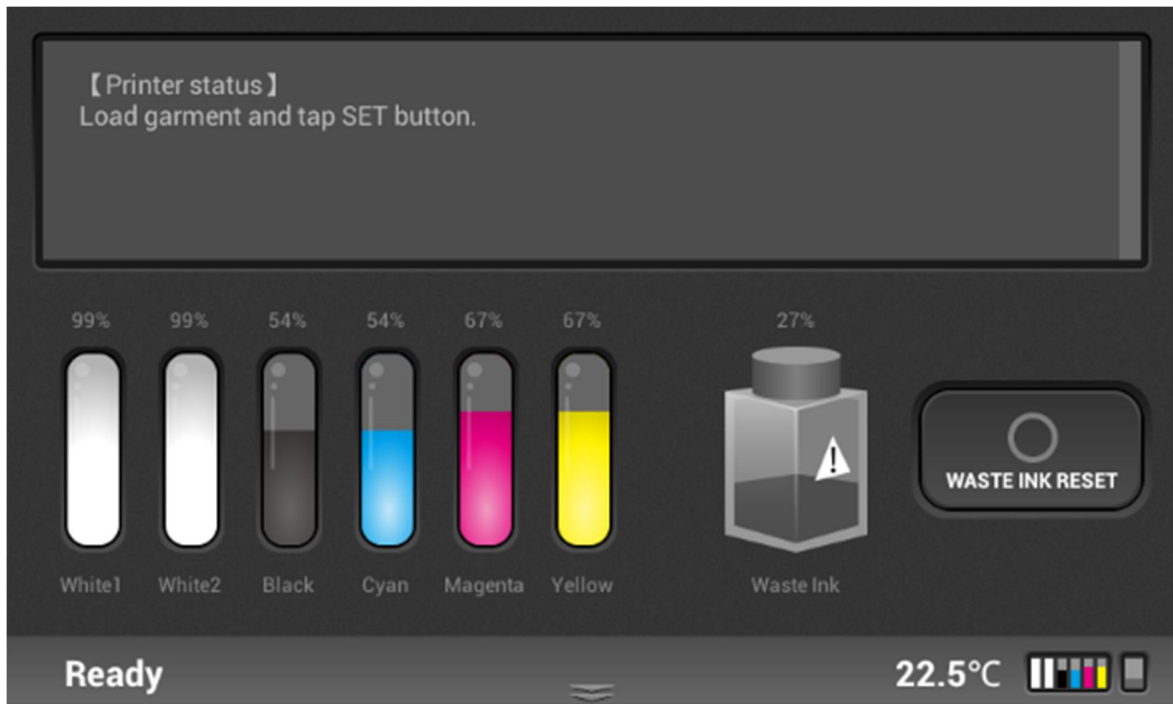

- To reset the waste ink counter, after the waste ink tank has been emptied, press [WASTE INK RESET] button.

CAUTION

- ❖ Do not reset the waste ink tank warning **WITHOUT** emptying the waste ink tank, this will avoid any spilling or other potential hazards

7 Adjustments

- This section describes how to adjust image quality of this printer from touch panel.
- Although the printer head nozzle status is good, if the printer quality is not good, this process need to perform.
- These functions can be performed on the  tab.

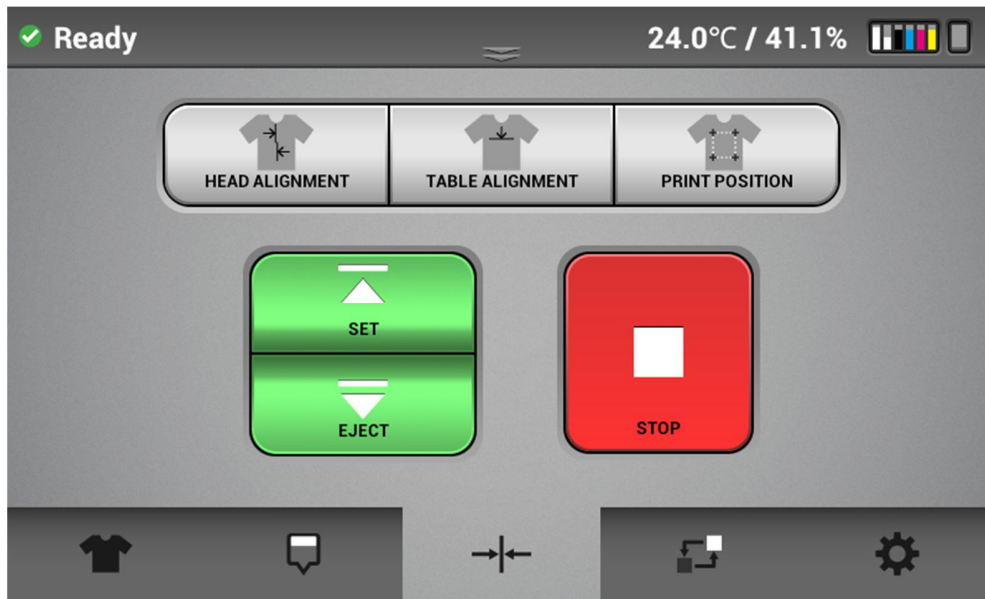

- You can print the basic adjustment pattern. Also it's better to print it on the transparent A4 media (such as OHP films).
- And it is recommended using medium-sized platen.

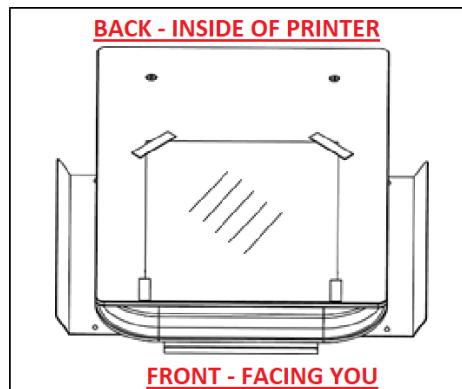

- If a part of the media is raised, use tape to fix the four corners of the media.



- Then, press the  (set) button to send the table into print-ready position

7.1 Adjusting Head

- This function adjusts the print head alignment position. When the print result is not clear (for example, vertical lines are misaligned, or color is not clear. Print is fuzzy) this adjustment may improve the result. NOTE: Always check the table height 1st. The reading on the dial should be close 0 in most cases. If the printing surface is too far away from the head the prints will be fuzzy and the lines may not appear straight



- Press the button, the pattern of adjusting head is printed.

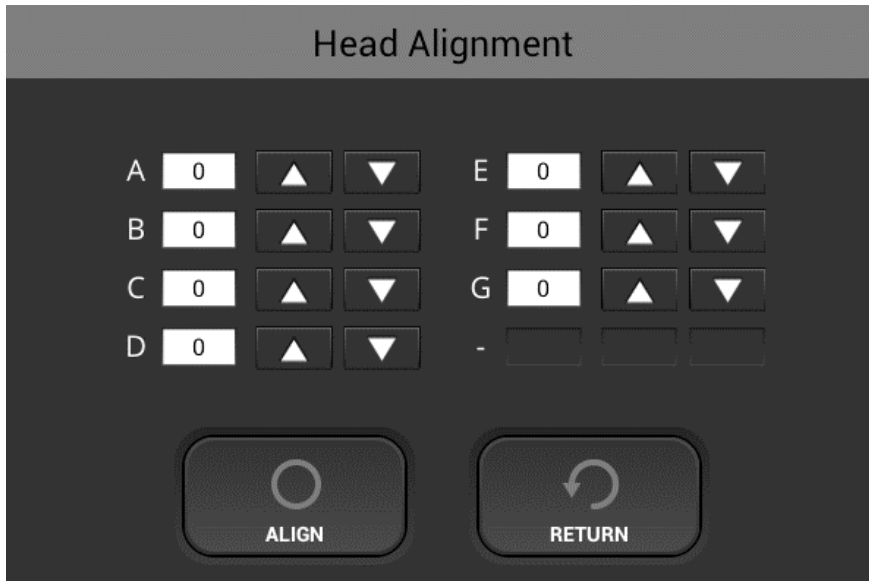

- After find an appropriate adjustment value form the print result of adjustment pattern.

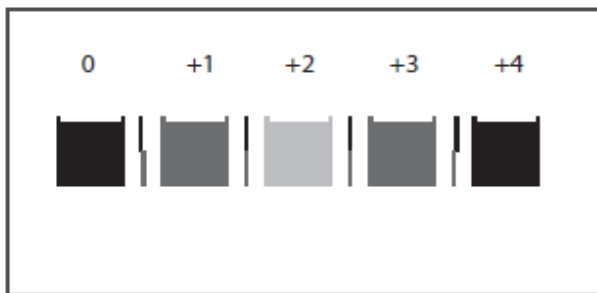

- Find a pattern with a square in the lightest color and vertical lines on both sides (or closest to this condition) aligned in row A
- Note the value indicated over the pattern indicates an appropriate adjustment value.
- An appropriate adjustment value is "+2". In this example
- Enter this value in the box for ROW A (up arrows make the value go up, down arrows make the value go down)
- Repeat this for the other rows in the test pattern (B, C, etc)

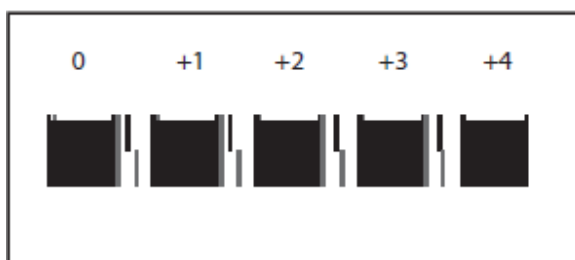

- When there are no straight vertical side lines, like upper illustration, check the last square out of the sequence of squares with the smallest gap in side lines and find a corresponding value.
- As upper illustration, the value is "+4".

After you have entered a value for all the rows, press the ALIGN button which sets the new values.

Reprint the pattern and repeat the above process

Repeat the process until all rows (A,B,C etc.) show the 0 column or close to the 0 column shown as the best value

You can always reset to the original settings by entering the factory reset button by going to the settings tab and select OPTION



7.2 Adjusting Table

- The printing indexing of the table can be adjusted.
- If the print result shows horizontal lines and the nozzle check is perfect (no missing nozzles and no nozzle deflection and the table height is correct), you need to do this function.
- Press the button of print position.



- Find an appropriate adjustment value from the print result of adjustment patterns.

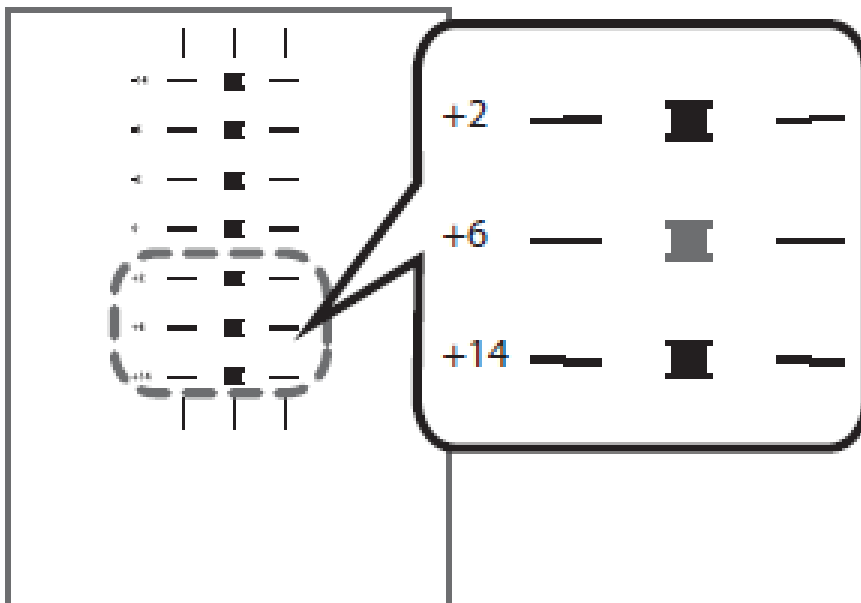

- Find a pattern with a square in the lightest color and horizontal lines on both sides aligned.
- A value on the upper of the pattern indicates an appropriate adjustment value.
- An appropriate adjustment value is "+6".

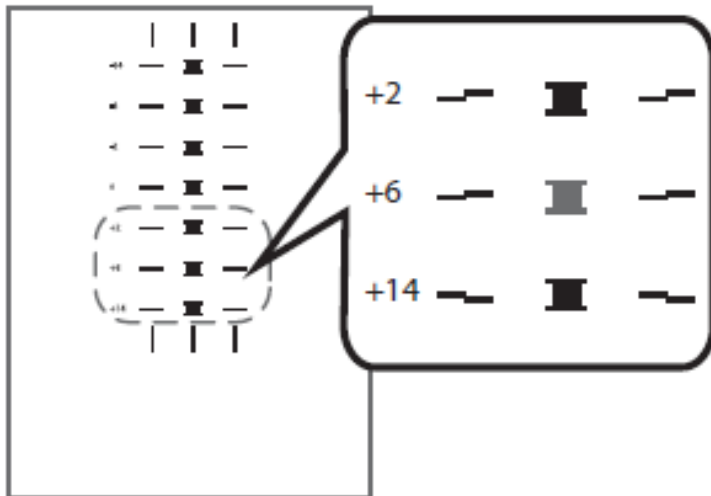

- In some cases, an adjustment value is an in-between value of patterns
- When a square is in the lightest color, but horizontal lines on both sides are misaligned.
- In the upper illustration, a square in the lightest color is for “+6”, but horizontal lines on both sides are misaligned. In this case check horizontal lines for one pattern above and one pattern below of the square.
- The horizontal lines for “+2” and “+6” are misaligned in the same direction, but the horizontal lines for “+14” are misaligned in the opposite direction.
 - In this case, a value that horizontal lines align exists somewhere in between “+6” and “+14”. After passing the value, the horizontal lines begin to be misaligned in the opposite direction as getting closer to “+14”
 - By referring to the alignment of the lines, decide a value between “+6” and “+14” as an appropriate adjustment value.

After entering the value press the ALIGN button and reprint the pattern

Repeat the process until the pattern print shows 0 or close to 0 as the best result as described above.

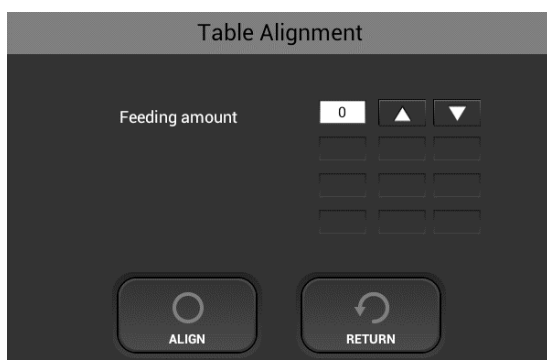

7.3 Adjusting the print position

- The printing start position can be adjusted accurately within the range of $\pm 4\text{mm}$. Use this if appears that the print is not centered.



- The button is for adjusting the printing position.

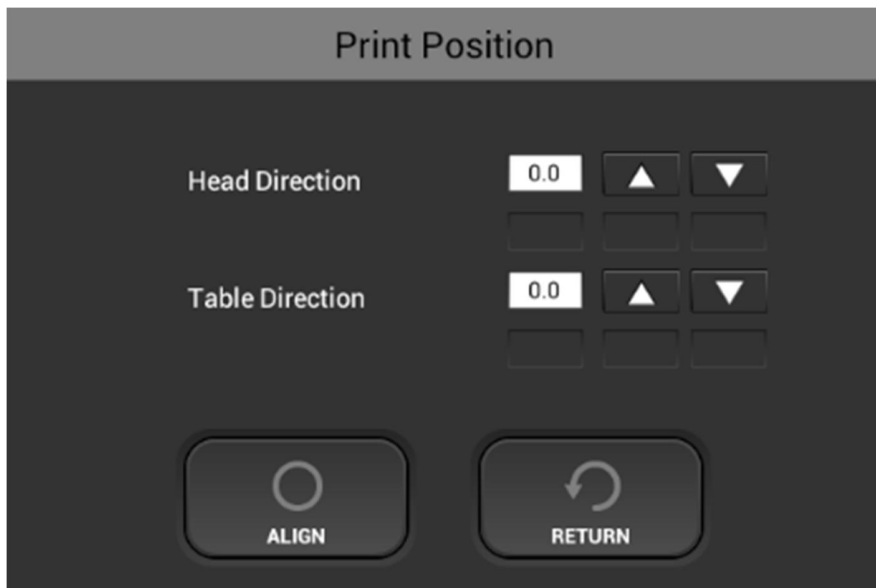

- After printing the pattern for the print position adjustment, you have to find appropriate value.

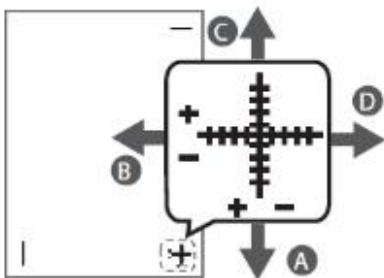

Position the paper so that the cross on the test print paper comes at the right bottom corner.

- Values can be selected between “-4.0” ~ “+4.0” in increments of 0.1mm.
- To move the print position to the “A” direction, input a value between “-1” and “-4” in the Table input area
- To move the print position to the “B” direction input a value between “+1” and “+4”. In the head input area
- To move the print position to the “C” direction input a value between “+1” and “+4”. IN the table input area
- To move the print position to the “D” direction input a value between “-1” and “-4”. IN the Head

d input area

After entering the values - press the align button to set the values

8 Replacing Service Parts

8.1 Service part

- This printer has some replaceable service parts that will need to be changed as discussed below

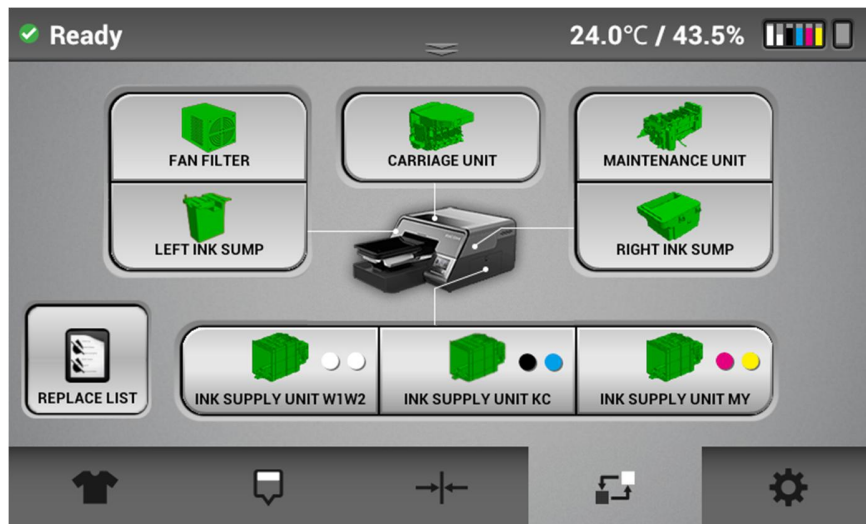

- Each icon will provide the status of each service part

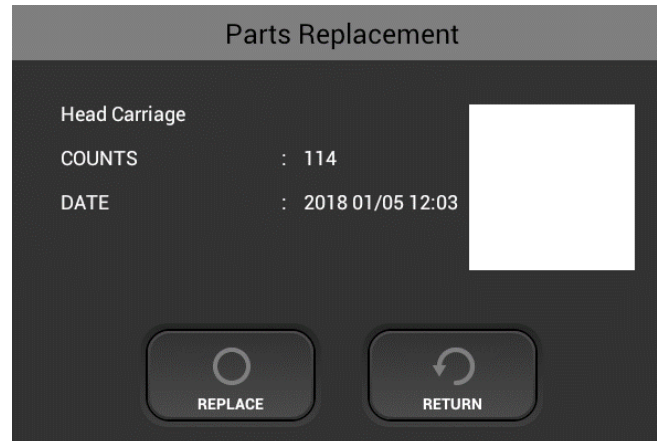

- When a component is selected, the replacement dialogue box is displayed. It shows the count and the date last replaced.
- The color of each component will be displayed in Green or Yellow and Red.



Green is normal

Yellow replace soon.

Red requires replacement.

8.2 Maintenance Schedule

Daily

The Ri 1000 will prompt you every 12 hours with the message below:

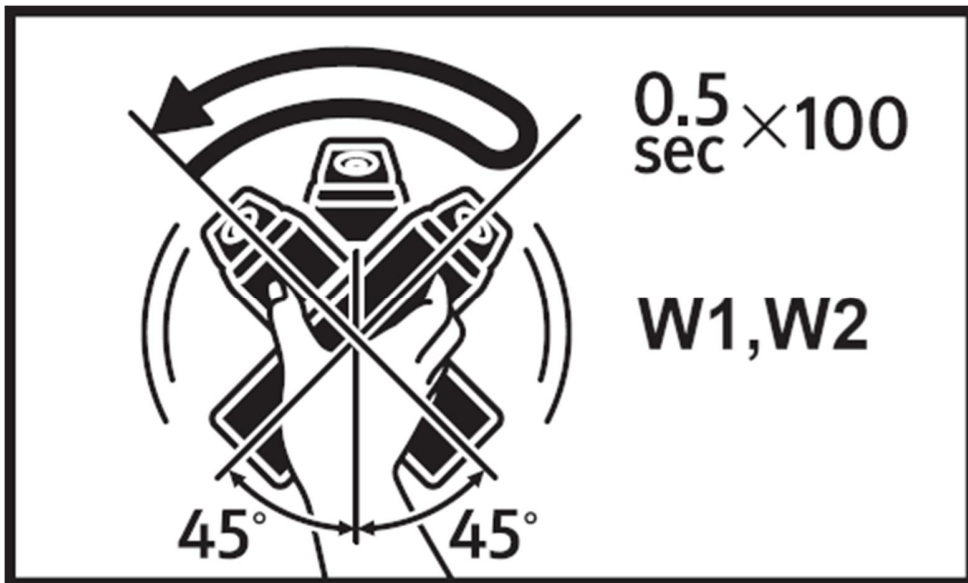

The stirring method should follow the following.

CAUTION:

DO NOT hit or drop it when stirring. As it may cause injury, cartridge damage, ink leakage.

DO NOT excessively agitate/swing. as it may cause ink leakage.

MUST AGITATE/SWING as instructed. Other methods may cause ink leakage.

- Hold the cartridge horizontally as shown in Fig. 1.
- Shake the cartridge in the direction of rotation left and right as shown in Figure 1. of the arrow in Fig. 1.
- Make the ink cartridge reciprocate for 50 seconds in the direction of rotation of the arrow in Figure 1 in the left and right directions.
- Shake speed is the speed to make two reciprocations per second.



Fig. 1

Warning

DO NOT shake cartridge too fast or hardly.

Weekly

The Ri 1000 will prompt you with the message below every **7 days**

When prompted you should perform

Clean the maintenance unit

Clean around the heads

Clean the encoder(Plastic sheet type(Previous type))

Grease the guide rails

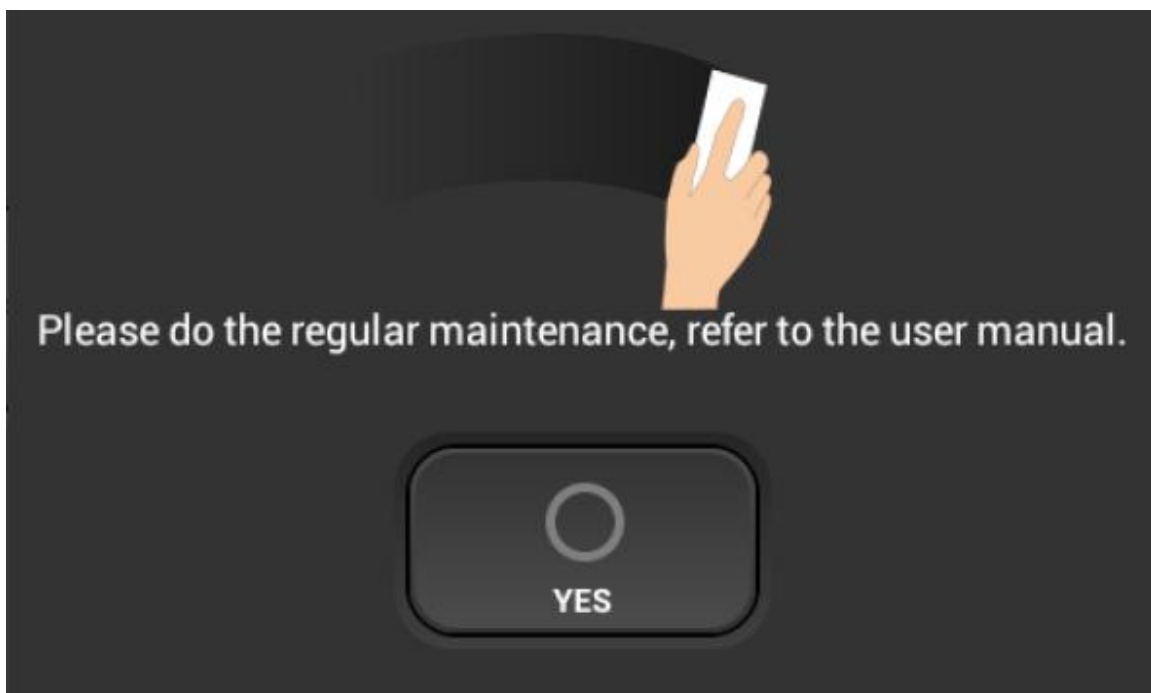

[About the encoder]

The encoder may be a metal slit type.(Depends on the time of purchase)

How to distinguish between metal slit type and plastic sheet type.



Metal slit type
Thin metal glossy sheet



**Plastic sheet type
(Previous type)**
Transparent plastic sheet

If your printer uses plastic sheet encoder strips:

Weekly cleaning is required. See "How to Clean the Guide Rod and the Encoder Strip" section for cleaning procedure.

If your printer uses metal slit type encoder strips:

In principle, cleaning the metal slit type encoder strip is not required.

The method of cleaning the metal slit type encoder strip is basically the same as its of plastic sheet.

Clean the encoder seat only when:

- Grease or ink drops on encoder strip.

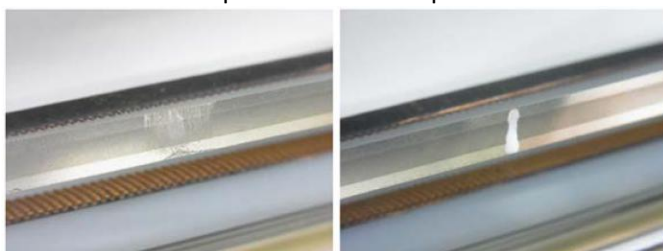

- Vertical stripes appear in the printed image.

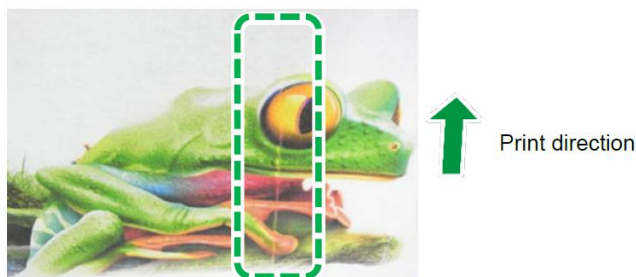

IMPORTANT! The slit part is fragile. Wipe it gently so as not to break or deform the slit part.

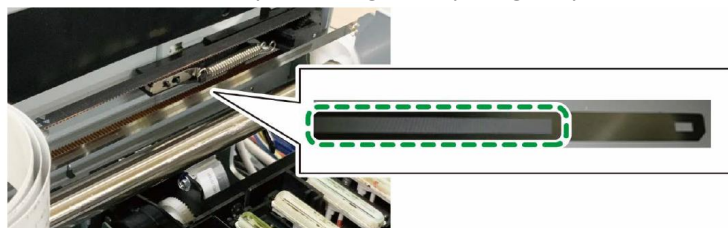

If it is difficult to remove ink or grease, wipe in the direction of the arrow below. The wiping direction must be parallel to the slit.

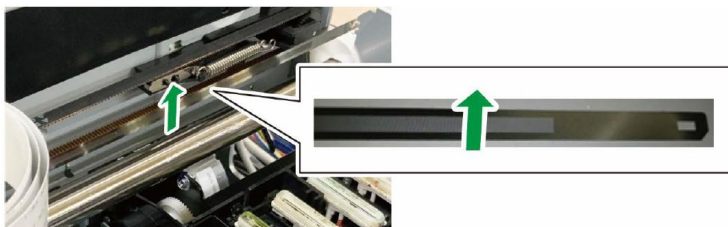

How to Clean the Maintenance Unit and the Flushing box

Cleaning part: The Maintenance Unit and the Flushing box

Timing of Cleaning: Cleaning once a week

Cleaning content: Clean the parts described below with wiping the Cleaning Applicator

impregnated with Cleaning Liquid. Wipe gently and politely.

Replace the Cleaning Applicator if it gets dirty.

Although it depends on the degree of contamination,

it is a standard to use about 5 to 10 in a series of cleaning work.

CAUTION

DO NOT rub too strongly. DO NOT wipe other than the areas indicated.

there is a possibility that parts may be damaged, deformed or detached.

If parts breakage, deformation, or detachment occurs, it may cause a machine failure.

Cleaning time: About 10 minutes

Things to prepare: Gloves (commercial product, one that does not pass ink) / To wear

Protective glasses or goggles (commercially available) / To wear

Cleaning Applicator dedicated to Ri 1000

Cleaning Liquid dedicated to Ri 1000

<Cleaning procedure>

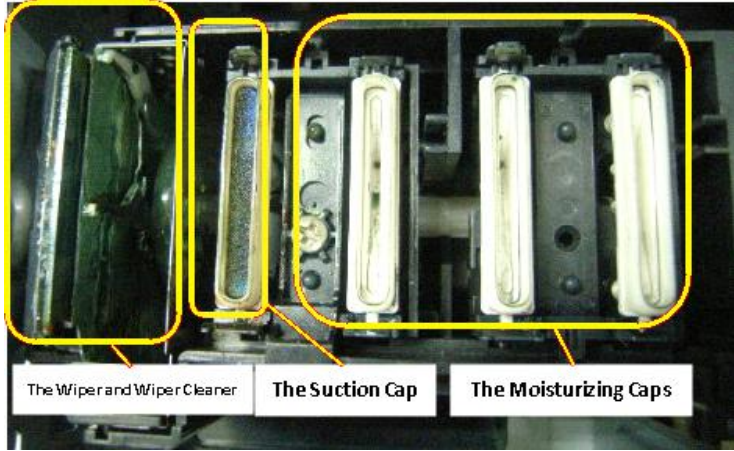
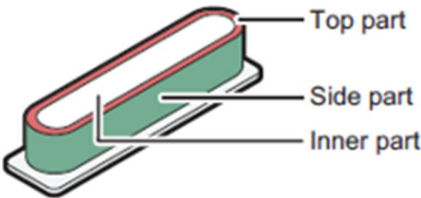
Contents	
Step 1	<p>Press the "MANUAL HEAD CLEAN" button. Then the carriage moves to the center position.</p>  <p>Fig. 1</p>
Step 2	Open the Front Cover.
Step 3	<p><Cleaning the Moisturizing Cap> The Moisturizing Caps (three pieces) in Fig. 1 gently wipes off the top part, the side part, and the inner part of the cap schematic diagram shown in Fig. 2. CAUTION: DO NOT to deform or scratch caps. Deformation and scratches may cause troubles. Especially wipe the top part gently and carefully.</p>  <p>Fig. 1</p>  <p>Fig. 2</p>
Step 4	Fig. 3 shows an example of how to apply the Cleaning Applicator.

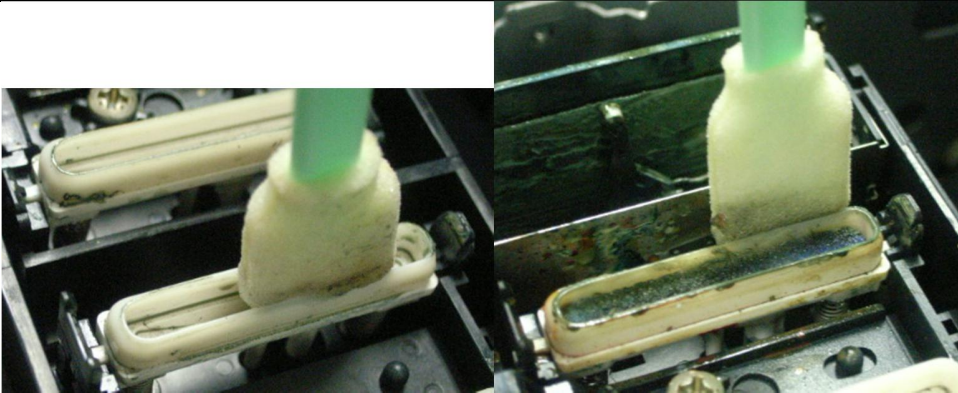
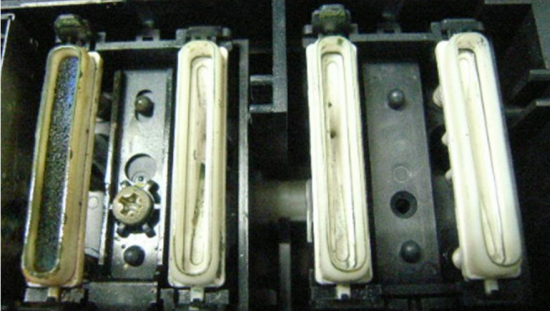
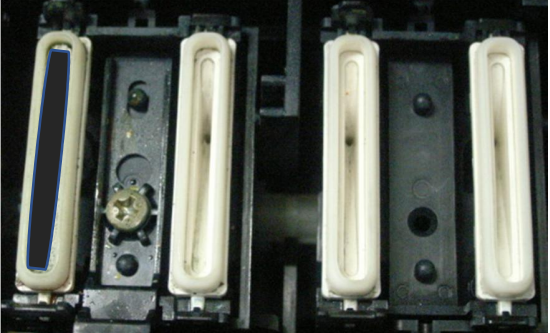
	 <p>Fig. 3</p>
<p>Step 5</p>	<p>Fig. 4 shows an example before cleaning, and Fig. 5 shows an example after cleaning. Dirt to the level of the example after cleaning.</p>  <p>Fig. 4 Before</p>  <p>Fig. 5 After</p>
<p>Step 6</p>	<p><Cleaning the Suction Cap> The method of cleaning the Suction Cap is the same as Step 3 the cleaning method of the Moisturizing Caps. However, there is a vacuum cap inset in the cap, clean it carefully so as not to shift or detach this part. Be sure to return the parts when the parts in the cap are displaced or removed. Press down until the spring bottoms out. If not returned properly, it may cause nozzle out. See Fig. 4 and Fig. 5 for the figures before and after cleaning. For parts inside the Suction Cap, it is sufficient that the solid ink or the stuck ink is removed.</p>
<p>Step 7</p>	<p><Cleaning the Wiper and Wiper Cleaner> 1. Cleaning the frame top of the Wiper Cleaner Clean of the frame top surface indicated by the yellow line in FIG. 6. An example of how to apply the Cleaning Applicator is shown in Fig. 7.</p>

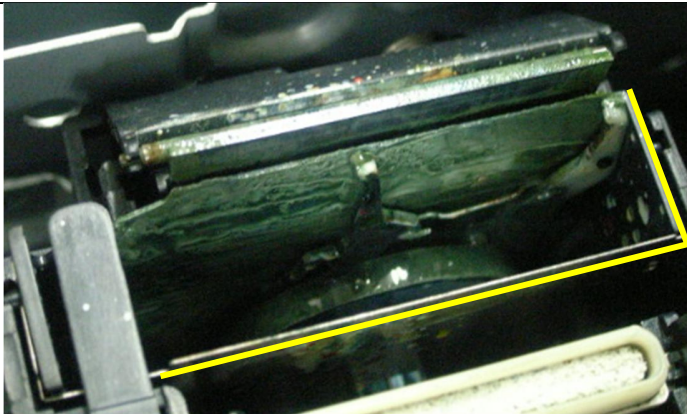

Fig. 6

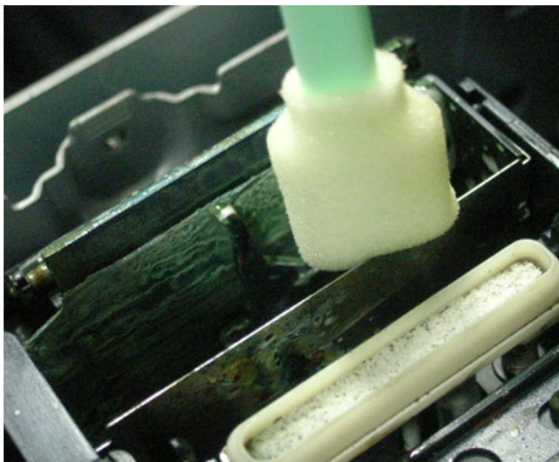

Fig. 7

Step 8

2. Cleaning the surface and the inside parts of the Wiper Cleaner

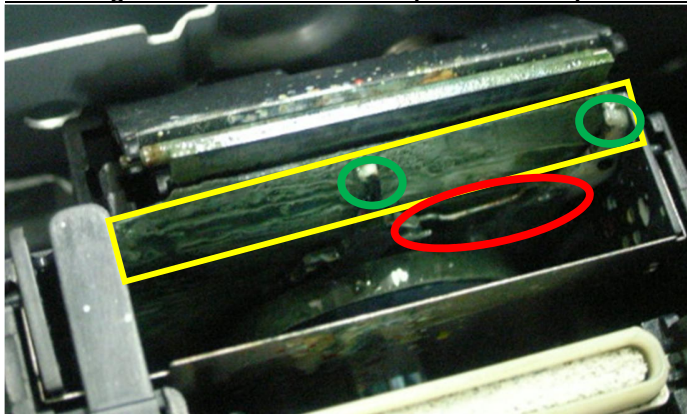

Fig. 8

Clean the area indicated by the yellow frame and the surface of the Lever indicated by the green frame in Figure 8.

- Be careful as the lever is thin, easily deformed, broken, and detached.
- Clean the lever to the surface of the green frame and wipe it gently.

ATTENTION:

- DO NOT touch the bottom side of the lever or the lower side of the range of the yellow frame.
- DO NOT use force cleaning the lever. It may easily deformed, broken, and detached.
- DO NOT touch the wire part surrounded by a red frame. There is a risk of dislodging or deforming.

For example, in Fig. 9, the Cleaning Applicator is put too deeply and it is NG. An example of work is shown in FIG. 10.



Fig. 9

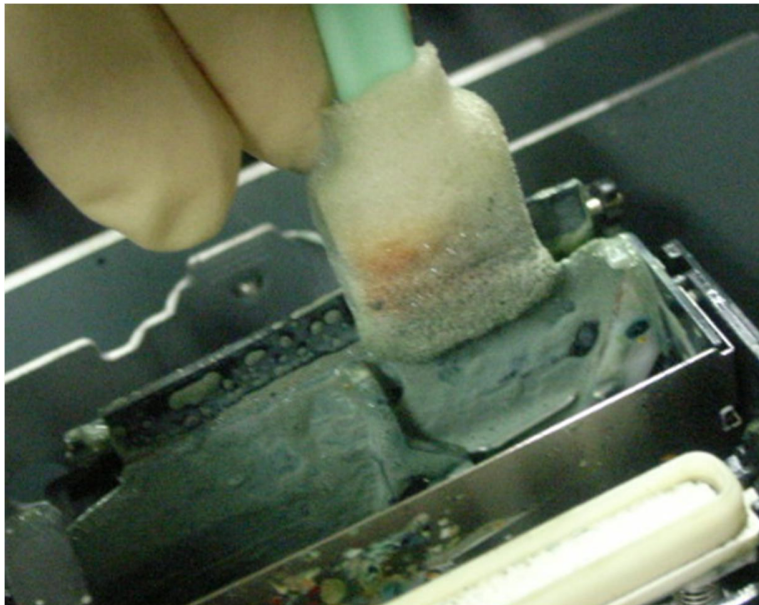

Fig. 10

Step 9

3. Cleaning of the Wiper

As shown in Fig. 12, Fig. 13, and Fig. 14, clean the front and back surfaces and the upper surface of the Wiper (rubber plate part surrounded by the yellow frame in Figure 11).

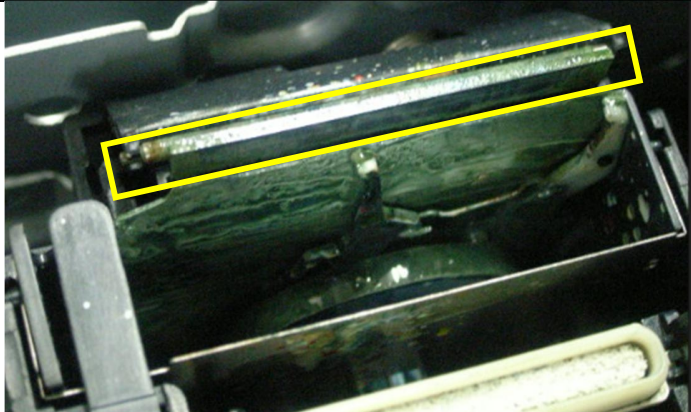

Fig. 11

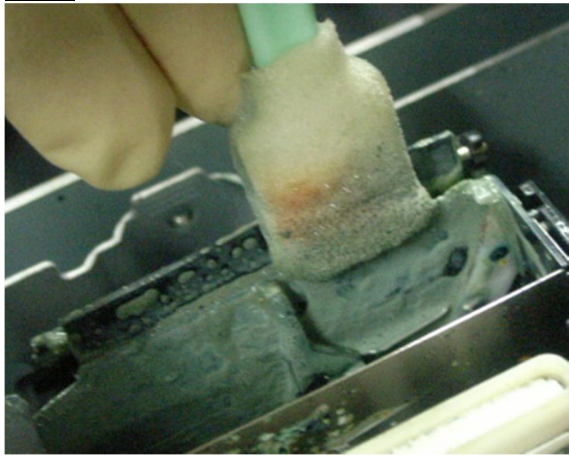

Fig. 12

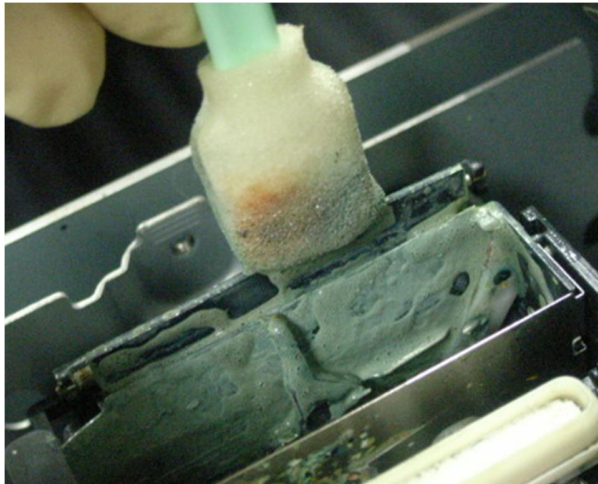

Fig. 13

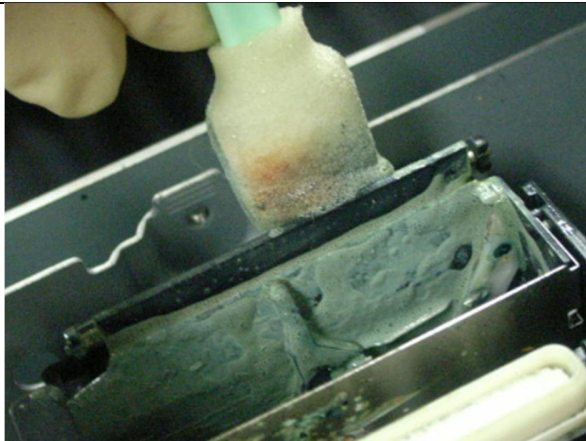

Fig. 14

Step 10

4. Cleaning up the Roller

As shown in Fig. 15, rotate the roller, move the Cleaning Applicator back and forth, and wipe the entire circumference.

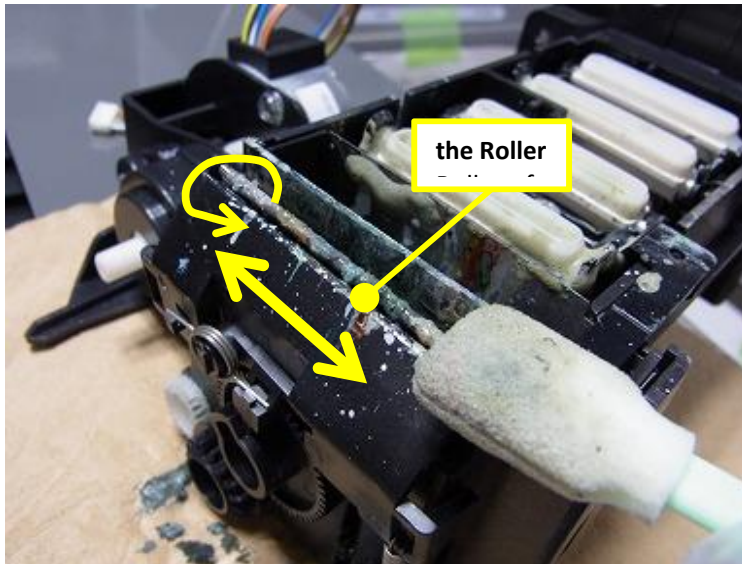

Fig. 15

Fig. 16 and 17 show the state after cleaning of the Wiper and the Wiper Cleaner described above. To remove dirt to this level.

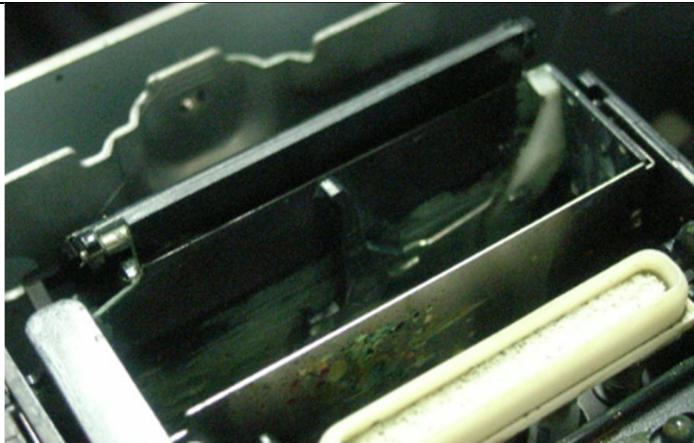

Fig. 16 After cleaning



Fig. 17 After cleaning

Step 11

<Cleaning the Flushing box>

If the top of the Flushing box is dirty with ink, clean it with a clean stick as shown in Fig. 18.

- After wiping off, do not leave convex ink on the top of the Flushing box.
- The part indicated by the red circle in Fig. 18 is fragile, so wipe gently.

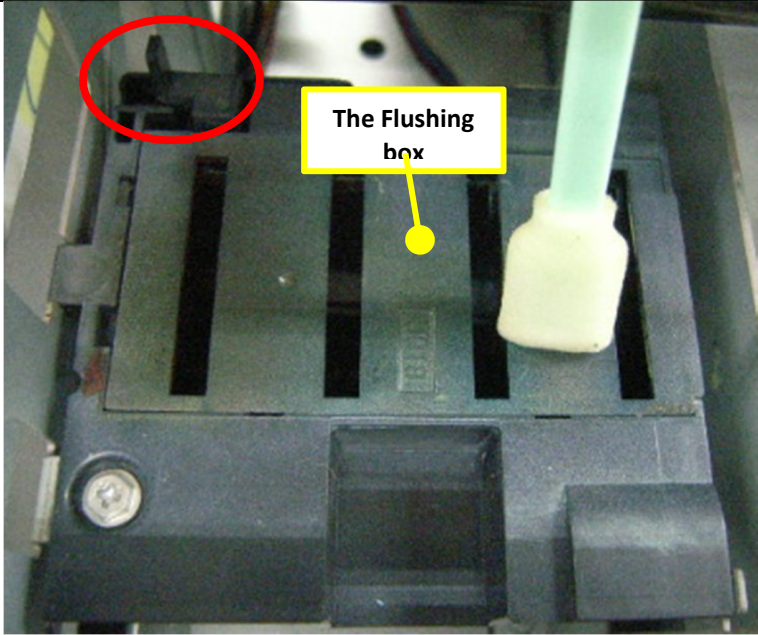
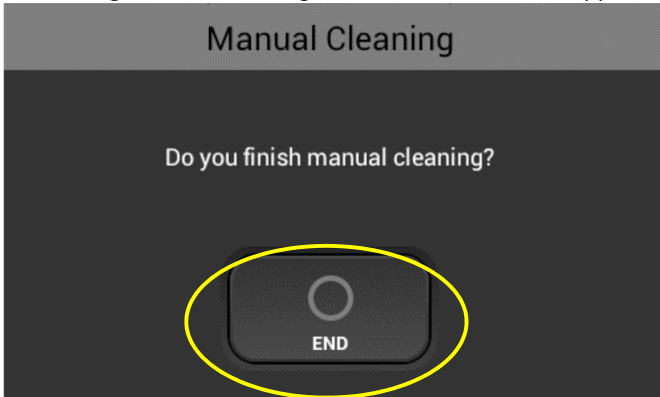

Fig. 18

Step 12 Clean the Encoder Sheet, if necessary. (See clean the encoder sheet instruction)

Step 13 Close the Front Cover.

Step 14 Press the "END" button.
The carriage moves to the right end, and the Head is capped.



Step 15 After completion of cleaning, perform "AUTO HEAD CLEANING". (Recommendation)
It prevents the ink from drying out and clogging the nozzles.



	After completion, it is recommended to print the Nozzle Check and check that the ink discharge is normal.
--	---

How to Clean the Cover of Head Nozzle Plate (the Nozzle Cover)

Cleaning part: The Nozzle Cover (Not clean the nozzle place)

Timing of Cleaning: Once a week



Cleaning content : In order to maintain the head discharge quality and to prevent the printed surface from becoming dirty,
Remove solid ink, lint, etc. that stuck to the Nozzle Cover.
Cleaning must be done with a dedicated cleaning kit.

Cleaning time: About 15 minutes

Things to prepare: Gloves (commercial product, one that does not pass ink) / To wear
Protective glasses or goggles (commercially available) / To wear
Cleaning Applicator dedicated to Ri 1000
Cleaning Liquid dedicated to Ri 1000

<Cleaning procedure>

	Contents
Step 1	<p>Press the "MANUAL HEAD CLEAN" button. The Head moves to the cleaning position of the Nozzle Cover.</p> 
Step 2	Open the Front Cover.

	
<p>Step 3</p>	<p>Put tray or paper under the Head. Prevents solid ink, lint and Cleaning Liquid from entering the unit during cleaning.</p>  <p>CAUTION: Do not move the head and platen by hand. It may cause a failure.</p>
<p>Step 4</p>	<p>Prepare a brand-new Cleaning Applicator (large) and the Cleaning Liquid.</p>  <p>Immerse the Cleaning Liquid into the Cleaning Applicator (large). For cleaning, use the Cleaning Applicator containing the Cleaning Liquid and the Cleaning Applicator not containing the Cleaning Liquid. CAUTION: Be sure to use Cleaning Applicator and Cleaning Liquid dedicated to Ri 1000. Otherwise, it may cause a failure.</p>
<p>Step 5</p>	<p>Look at the bottom of the Head and clean the Nozzle Cover periphery. Clean according to the following instruction 【Details of cleaning part】 .</p>



【Details of cleaning part】

<① nozzle cover surface>

Clean the surface of the specified area of the Nozzle Cover with the Cleaning Applicator containing the Cleaning Liquid.

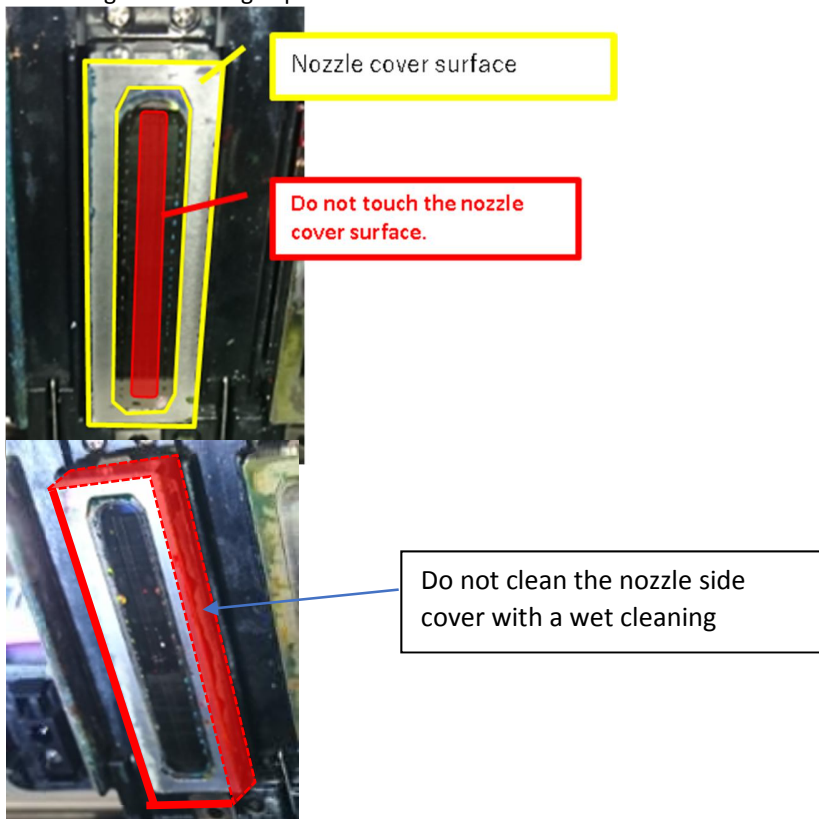

As shown in the figure below, clean along the arrow direction.

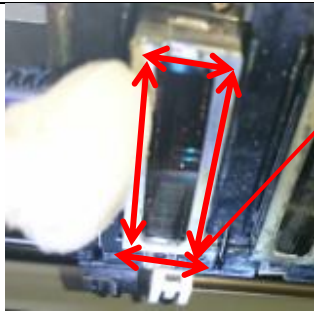

Clean Along the arrow direction as shown

CAUTION:

Be careful not to touch the Nozzle with the Cleaning Applicator.

Also, be careful not to adhere the wiped solid ink or lint to the Nozzle.

Also, be careful not to keep the nozzle area dry (no cleaning fluid) while cleaning the side of the print head

All of these can cause the nozzle out.

<② the stepped portion of the Nozzle surface and the Nozzle Cover >

Wipe off any dirt adhering to the stepped portion of the Nozzle surface and the Nozzle Cover.

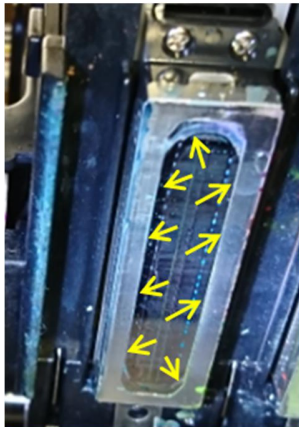

The step portion between the nozzle surface and the nozzle cover.



* After cleaning ① and ②, if washing the Cleaning Liquid and foam etc. attached to surplus have adhered to the Head, wipe it off with the dry, cleaning Applicator that does not contain the Cleaning Liquid. (it is important not to leave wet cleaning fluid on any part of the head after this manual clean)



<③ Head part side part>

Clean the side of the Nozzle Cover with the dry, cleaning Applicator that does not contain the Cleaning Liquid.

When cleaning the side of the Nozzle Cover, scrape the dirt along the direction of the arrow in the figure below and clean it.

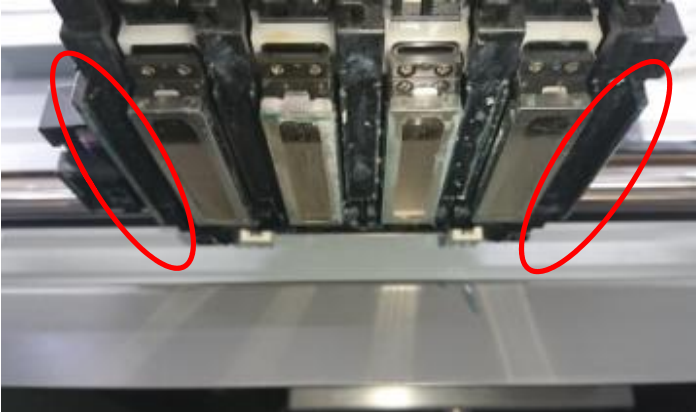

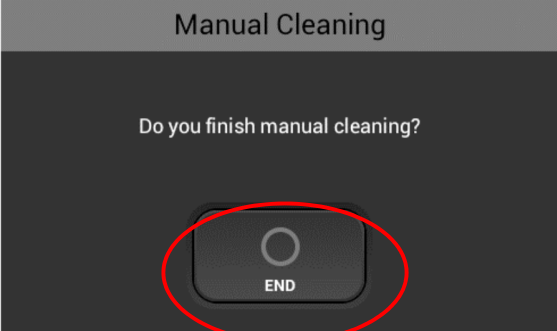
	<p>CAUTION: Do not clean the Nozzle Cover side with a Cleaning Applicator containing the Cleaning Liquid. If bubbles and liquid adhere to the side of the Head, it may cause a failure.</p> <p>CAUTION: Do not wipe the protrusion of the Nozzle Cover downward as shown below. The Nozzle Cover may come off causing failure.</p>   <p>Reference: Cleaned the Nozzle Cover</p>
<p>Step 6</p>	<p>Clean the left and right ribs on both ends of the carriage.</p> 
<p>Step 7</p>	<p>After cleaning the Nozzle Cover, remove the tray or paper placed under the Head.</p>
<p>Step 8</p>	<p>Close the Front Cover.</p>
<p>Step 9</p>	<p>Press the "END" button. The carriage moves to the right end, and the Head is capped.</p>

		
Step 10	<p>After completion of cleaning, perform "AUTO HEAD CLEANING". It prevents the ink from drying out and clogging the Nozzles.</p>  <p>After completion, it is recommended to print the Nozzle Check and check that the ink discharge is normal.</p>	

How to Clean the Guide Rod and the Encoder Strip

Cleaning part: The Guide Rod and the Encoder Strip

Timing of Cleaning: Cleaning once a week

Cleaning content : Clean the Guide Rod and the Encoder Strip to maintain head ejection quality and allow normal operation of the carriage.

Apply grease to the Guide Rod,
and clean the Encoder Strip with Cleaning Liquid.

Cleaning work should be carried out until completion, without interruption.

Also, sure to use Cleaning Applicator and Cleaning Liquid dedicated to Ri 1000.

Otherwise, it may cause a failure

Cleaning time: Half an hour

Things to prepare: Gloves (commercial product, one that does not pass ink) / To wear

Protective glasses or goggles (commercially available) / To wear

Cleaning Applicator dedicated to Ri 1000





Grease dedicated to Ri 1000



Lint Free Wipe dedicated to Ri 1000

Cleaning Liquid dedicated to Ri 1000

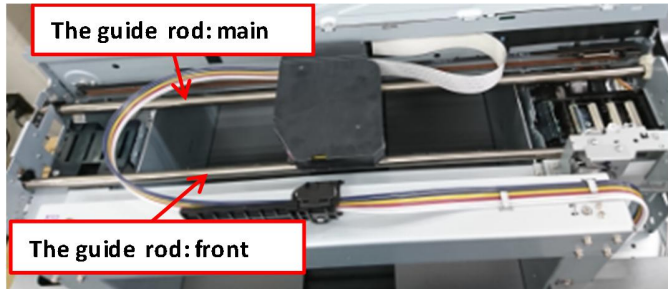
[NOTE]For safety instructions, please refer to Safety Information and Quick Installation Guide that came with the printer.

<Cleaning procedure>

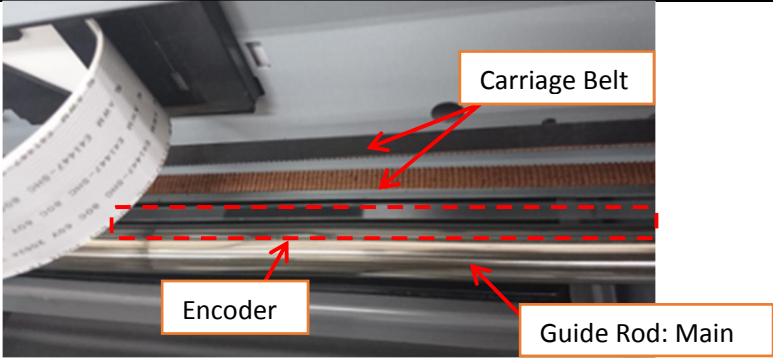
Contents	
<p>Step 1</p>	<p>When the movement of the Platen is completed, Press the “MANUAL HEAD CLEAN” button. Then the carriage moves to the center position.</p> 
<p>Step 2</p>	<p>Open the Front Cover.</p> 
<p>Step 3</p>	<p>Wipe off the old grease and lint stuck on the guide rod with a cleaning applicator. There are two guide rods "guide rod: front" and "guide rod: main". To clean both two.</p>   <p>(Caution) When cleaning the guide rods, try to avoid touching the encoder or the carriage belt. The printer may not operate properly.</p> <div style="border: 1px solid black; padding: 2px; display: inline-block;">Cleaning applicator</div>

	
<p>Step 4</p>	<p>Apply dedicated grease to the Guide Rod. Use new Cleaning Applicator(large) for application.</p>  <p>CAUTION: Be sure to use the Cleaning Applicator dedicated to Ri 1000 and dedicated grease. This grease is designed for this purpose and the applicators are lint free – use of incorrect grease and the accumulation of lint can cause the carriage to malfunction and need to be replaced if the guide rods are not cleaned and greased correctly</p>
<p>Step 5</p>	<p>As shown in Fig. 1, <The Guide Rod: main> Apply approximately 0.01 ml of grease to each of the six peripheral parts of the arrow. <The Guide Rod: front> The six peripheral parts of the arrow. After putting grease, apply it to the full range of the dot-dash line and adjust it. Refer to Fig. 2 and Fig. 3 for the circumferential grease application range of the Guide Rod.</p>

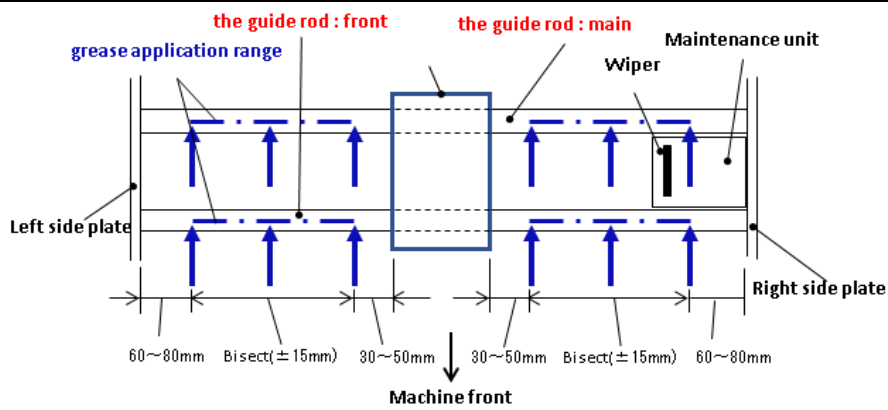

Fig. 1: Grease coverage

<Sample amount of grease to be applied to six places each rod>

	At putting	After applying
0.01~ 0.02ml (height: 2mm)		

<Circumferential grease application range >

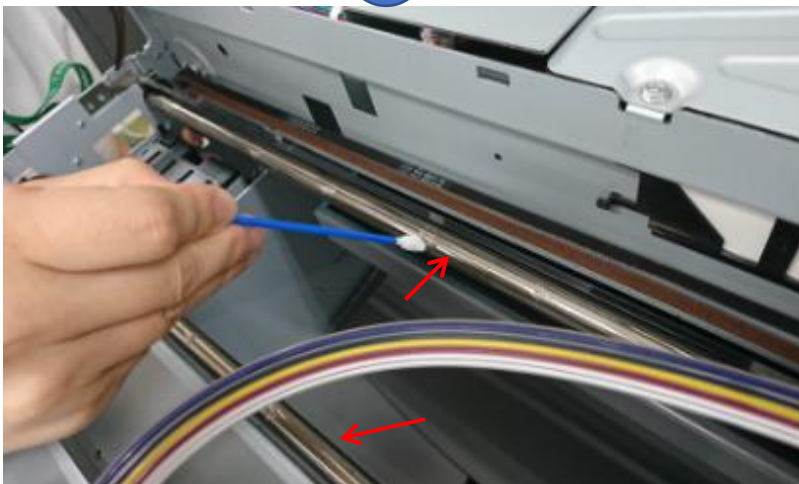

Use a dedicated Cleaning Applicator to spread the grease smoothly on the top portion of the rod (cover about the top third of the circumference of the rod.)

Grease the top of
the rod in this area

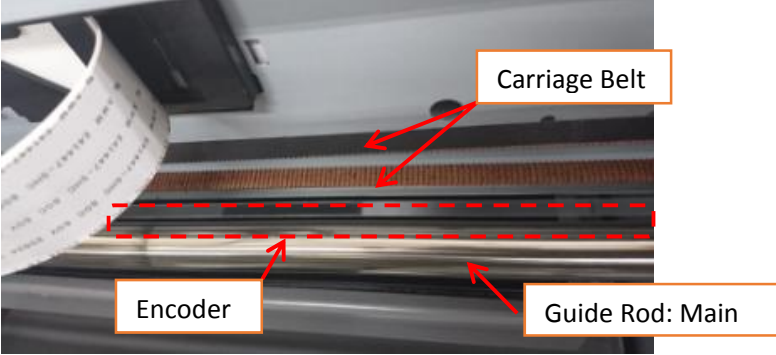
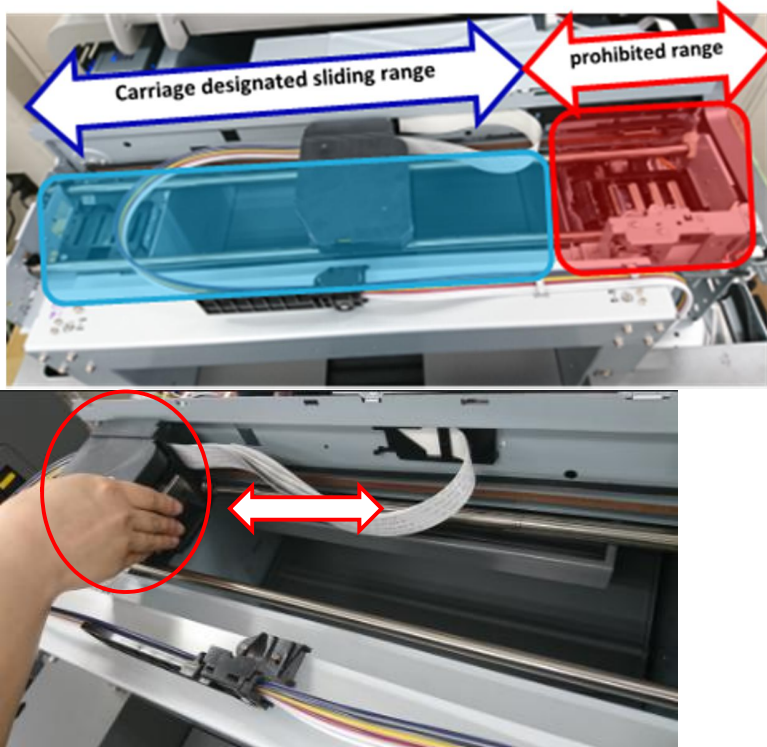

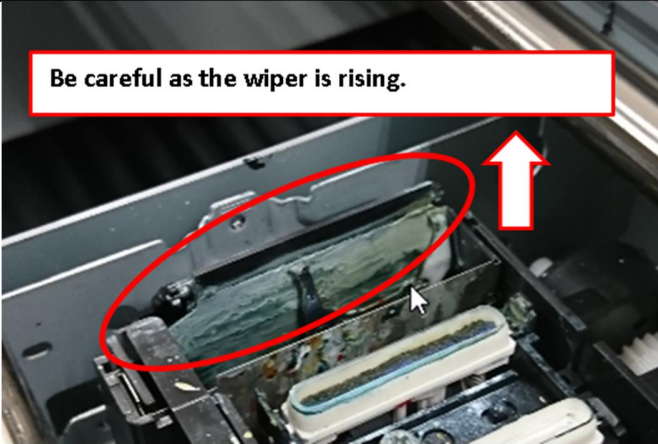
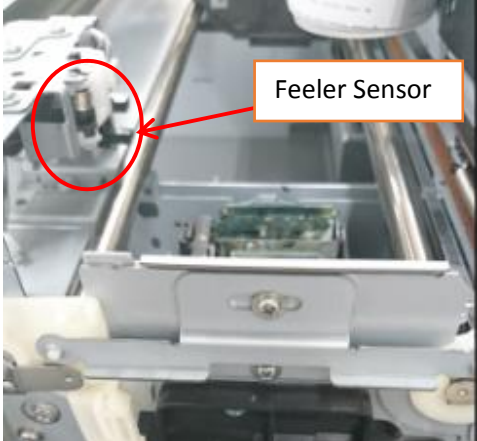
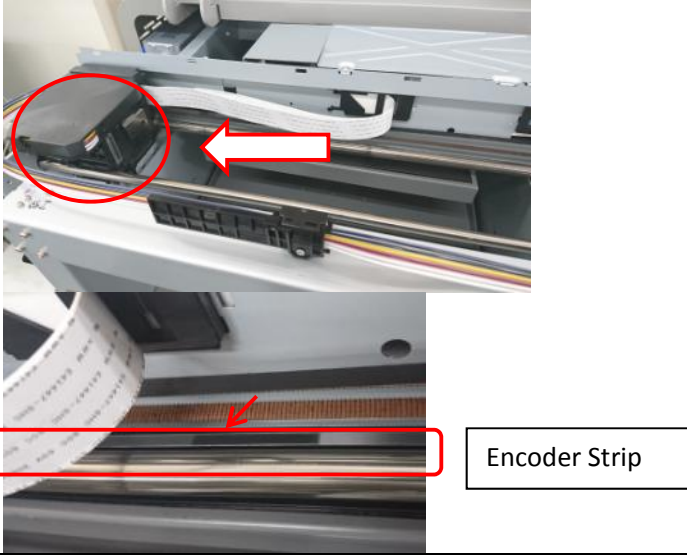
	<p>CAUTION:</p> <ul style="list-style-type: none"> • Do not allow grease to adhere to the Encoder • Do not allow grease to adhere to the carriage Belt.  <ul style="list-style-type: none"> • Do not allow grease to adhere to the carriage •
<p>Step 6</p>	<p>Move the carriage to the left and right by hand, to smooth the grease. Move the carriage slowly over 2 seconds within the designated sliding range, and move it more than two round trips.</p>  <p>CAUTION: Do not move the carriage to the sliding prohibited range which is outside the designated sliding range. Since the wiper of the Maintenance Unit is raised to the Wiper cleaning position, when the carriage is moved to above the Maintenance Unit, the Wiper interferes with the Head, it may damage the Head.</p>

	 <p>Be careful as the wiper is rising.</p>
Step 7	<p>Wipe away grease that protrudes far beyond the coverage of Fig. 1, 2 and 3. Also, confirm that grease is not attached to the Feeler Sensor.</p>  <p>Feeler Sensor</p>
Step 8	<p>When to clean the encoder strip depends on the type of encoder strip installed. See "Weekly" section of "Maintenance Schedule". Clean the Encoder strip after applying grease to the Guide Rod. Move the carriage to the left end side by hand.</p>  <p>Encoder Strip</p>

<p>Step 9</p>	<p>Wet a Lint Free Wipe with the Cleaning Liquid.</p> <div data-bbox="311 324 917 582"></div> <div data-bbox="311 593 1278 728" style="border: 1px dashed black; padding: 5px;"><p>Alternatively, ethanol (commercially available) can be used for cleaning. Using ethanol to clean the encoder strip will be faster. Although, results may vary. Never use ethanol in other places such as the nozzle cover or maintenance unit.</p></div>
<p>Step 10</p>	<p>Using the Lint Free Wipe impregnated with Cleaning Liquid, remove lint and ink adhering to the Encoder strip. Wipe from the right edge of the encoder strip to near the carriage. Move the carriage to the center to wipe the remaining part of the encoder strip and finish cleaning the entire Encoder strip. Repeat this procedure for 3 to 5 times.</p> <div data-bbox="311 896 917 1164"></div> <div data-bbox="311 1187 853 1467"></div> <p>CAUTION:</p> <ul style="list-style-type: none">• Be sure to clean in the direction of the arrow in the figure.• Do not directly touch the encoder strip with hands.• Do not bend the encoder strip.• Do not allow the Cleaning Liquid to adhere to the timing belt.• Do not allow the Lint Free Wipes to come into contact with the Guide Rod. If you do accidentally touch it, make sure to re-apply grease.

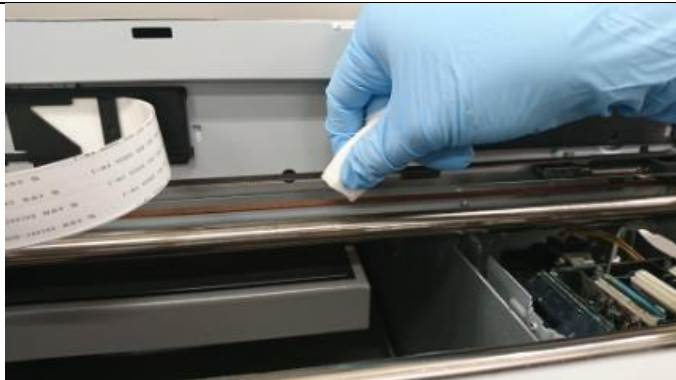

All of these can cause a CR encoder error and the encoder will have to be re-cleaned.



Step 11 Clean the encoder strip as same way as Step 10 with a Lint Free Wipe moistened with water (a low impurity water, distilled water is strongly recommended).
Wipe twice.
[NOTE]If you are using ethanol with very few impurities, this step can be skipped.

Step 12 Clean it as the same way as Step 10 using a dry Lint Free Wipe due to remove the remaining liquid droplets and so on.
Wipe once. Gently wipe it.
If you wipe too hard, the encoder strip may be scratched.

Step 13 After cleaning the Encoder, move the carriage to the left side. If you don't, the wiper may damage the Carriage during homing procedure.

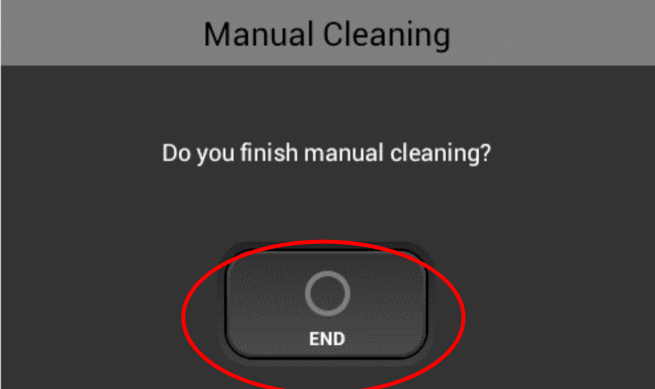

The Wiper may hurt the Head if it makes it stand by on the right end Maintenance Unit.

Step 14	<p>Close the Front Cover.</p> <p>Press the "END" button.</p> <p>The carriage moves to the right end, and the Head is capped.</p> 
Step 15	<p>After completion of cleaning, perform "AUTO HEAD CLEANING". It prevents the ink from drying out and clogging the nozzles.</p>  <p>After completion, it is recommended to print the Nozzle Check and check that the ink discharge is normal.</p> <p>NOTE:</p> <ul style="list-style-type: none">· If dirt remains on the encoder strip after cleaning, clean again.· If the problem persists, please contact your dealer.

8.3 Preparing Your Printer for Storage/Shipping

Note: Please have cleaning cartridges available for all channels

- Remove Ink Cartridges
- Insert Cleaning Cartridges

- Go to  tab

- Select 

- Select 

- Confirm by selecting YES to charge the system with cleaning solution

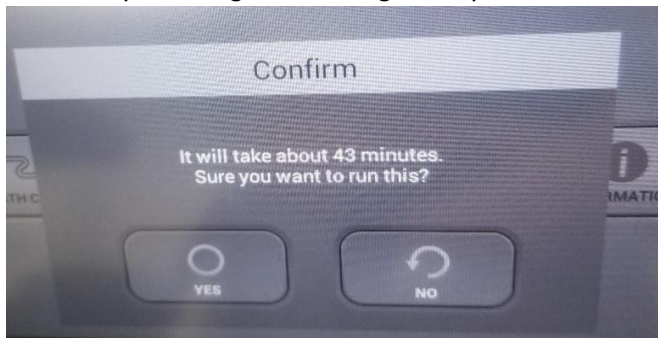

8.4 Using Printer in 4-color mode (CMYK Only)

Using the printer in Four (4) color mode, allows you only to use CMYK and keep the white in a storage mode.

1. Insert the Cleaning cartridges designated for W1 and W2 channels
2. Select [INK PATH CONTROL] from the [SETTING] tab



3. Select [CLEANER CHARGING]
4. Select [WHITE ONLY]

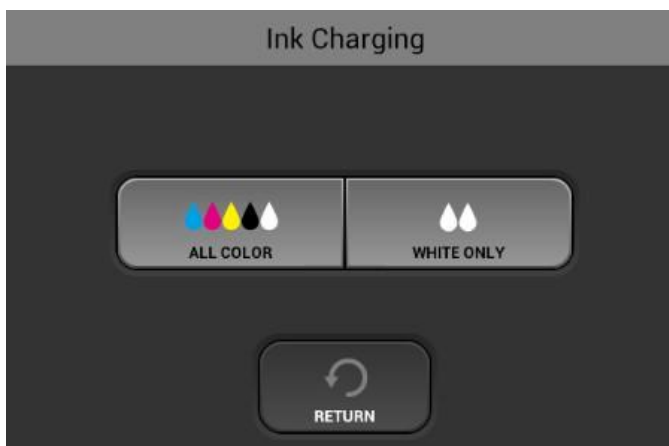

***PLEASE ALLOW UP TO 40 MINS (APPROX.) FOR THE SYSTEM TO FLUSH THE INK OUT AND FILL THE WHITE LINES WITH CLEANING SOLUTION**

8.5 Ink Path Guide

Status	Printable media	Remarks
Ink in all channels 6 Color mode After ink charging state	White media, Dark media (requiring underbase)	All kinds all printing
Color ink in color channel Cleaner in white channel 4 color mode After ink without white state	White media	OK for any printing that does not require a white under base The Cleaner in white channel is for protect the nozzle of print head.
Cleaner in all channels. After cleaner charging state	unprintable	For long term storage./ Shipping

10

Ink Stage Change Map

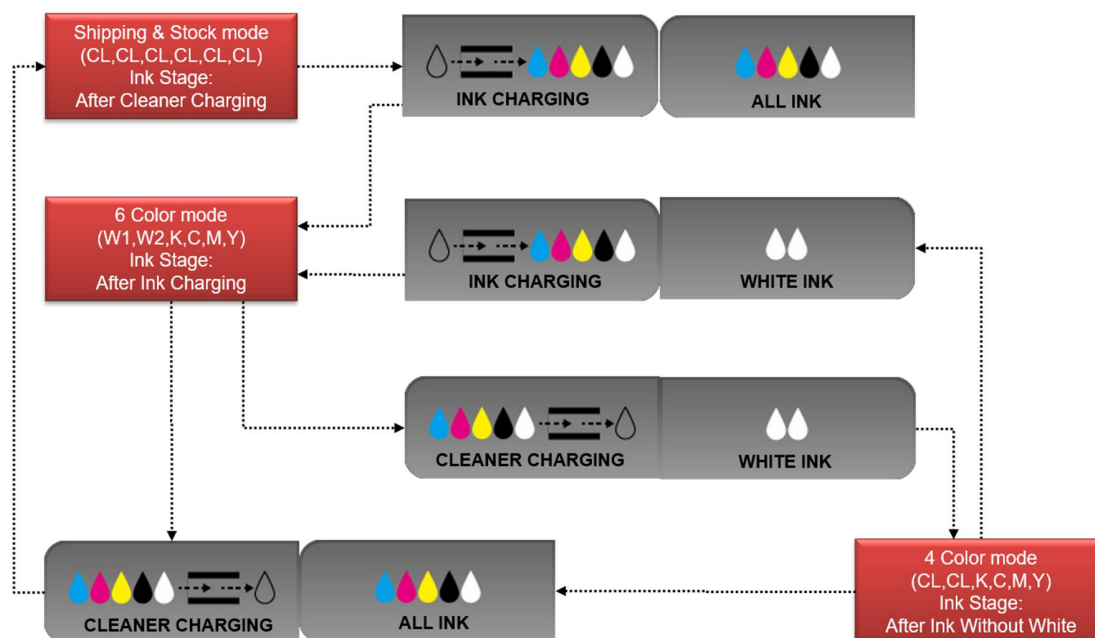

9 Updating Firmware

WARNING: Do not perform a firmware update unless the printer is in Ready Status



9.1 Updating Firmware

1. Download the application from <http://support.ricoh.com/bb/html/direction/re2/model/ri1000/ri1000.htm>
2. Open the Printer Manager Application
3. Enter the printer IP address needing to be updated

A screenshot of a web interface showing an "IP Address" label followed by a text input field containing the IP address "192 . 168 . 1 . 71".

4. Select the version to use for the update

A screenshot of a web interface for firmware updates. It shows an "IP Address" field with "192 . 168 . 1 . 71". Below it is a dropdown menu for "SCB" with "STM_GNX317W_SCB_GX180731.bin" selected. There are two buttons: "SCB F/W UPDATE" and "START UPDATE". Below these is a dropdown menu for "GIB" with "ries_1_32_6_180809.apk" selected. A list of other firmware files is visible: "ries_1_32_0_180507.apk", "ries_1_32_1_180608.apk", "ries_1_32_2_180622.apk", "ries_1_32_3_180630.apk", "ries_1_32_4_180710.apk", "ries_1_32_5_180727.apk", and "ries_1_32_6_180809.apk". At the bottom, there is a "CTL" label and the selected file "ries_1_32_6_180809.apk".

5. Click the F/W Update button then select START UPDATE to send the firmware update
Note: always update the Interface Board first prior to any firmware updates

6. Wait for the notification that the firmware update delivery is complete

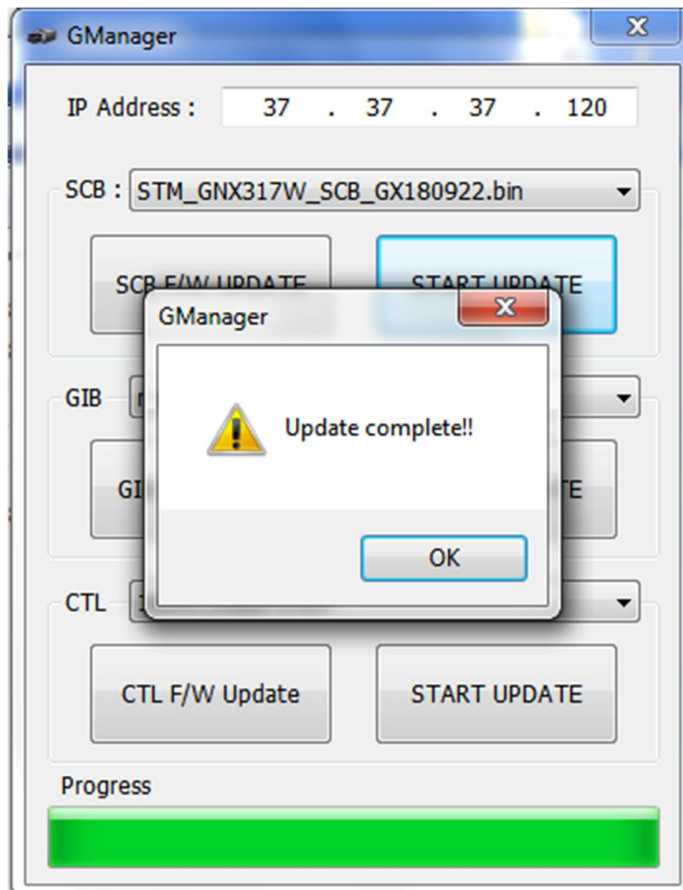

7. Click **OK** on your printer's screen to continue the update

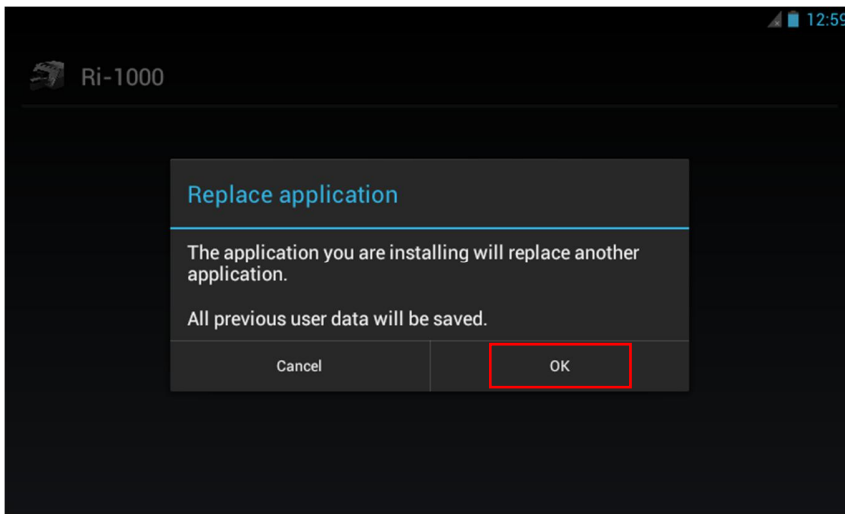

8. Click the **install** option on the screen to continue

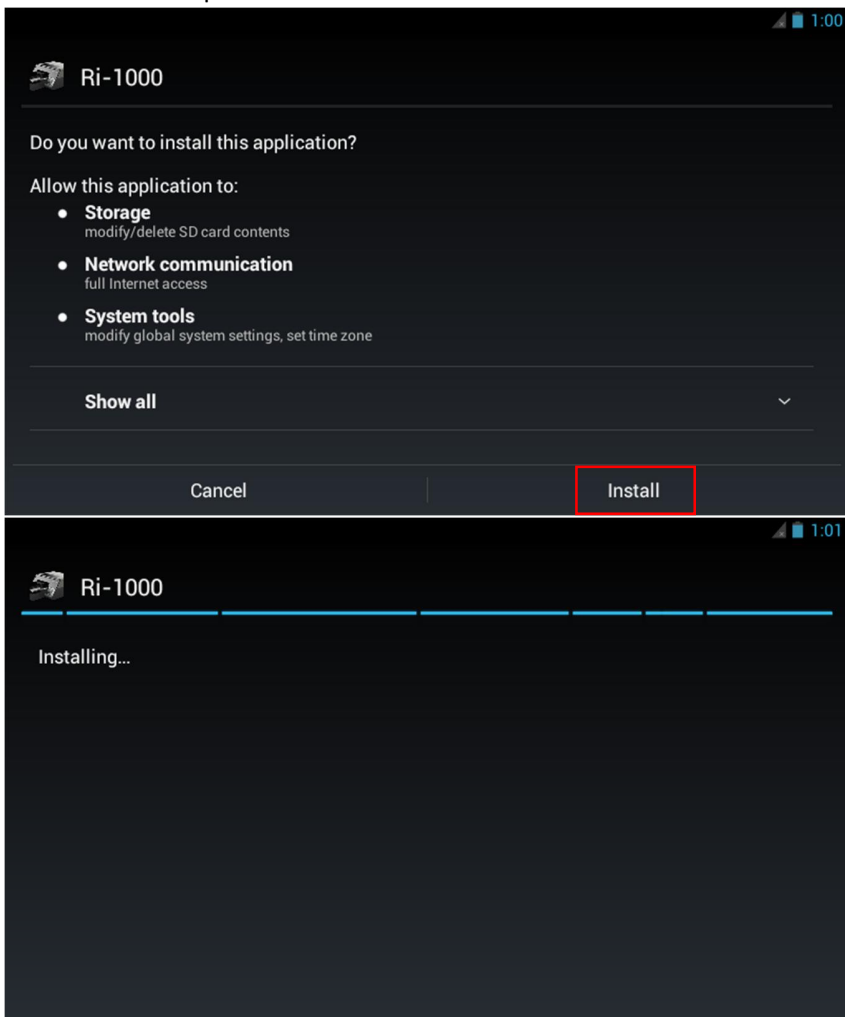

9. Then select **open**

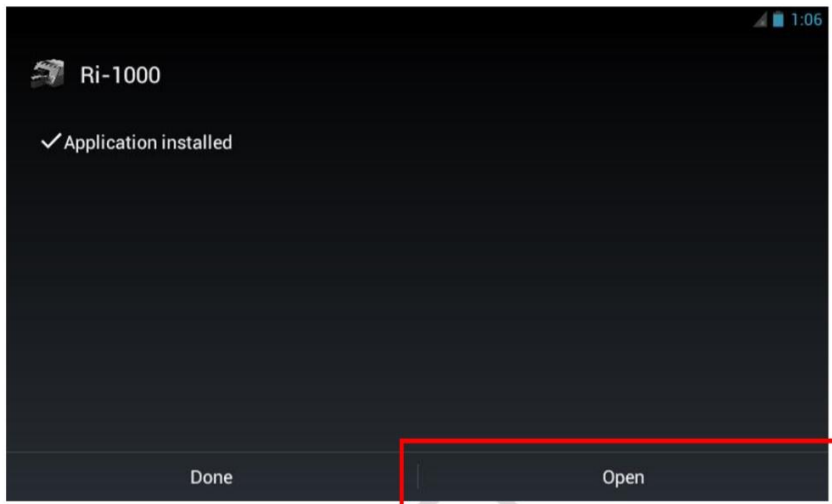

10. Wait for the update to complete then restart the printer as instructed by pressing the **yes** button

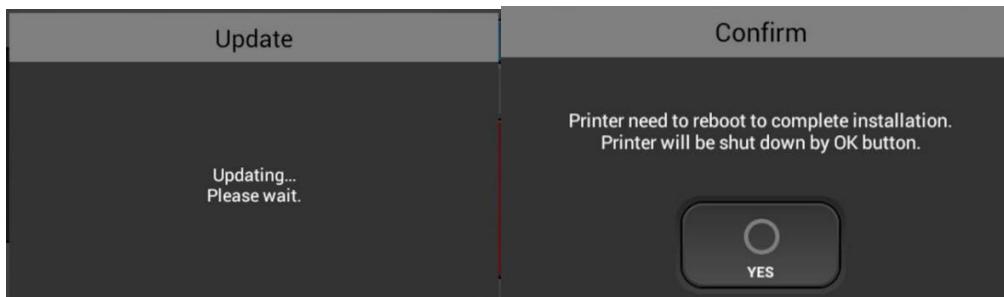

- Go to the information section in the settings tab

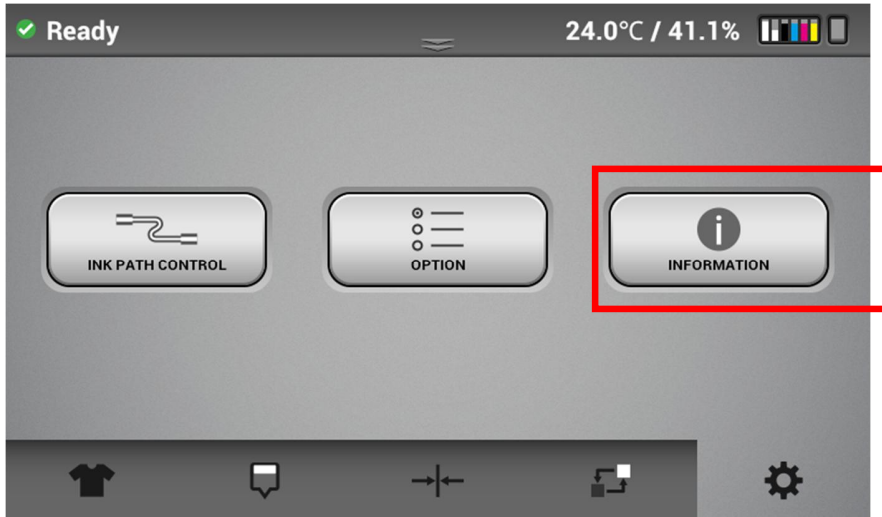

- Verify the Firmware version matches the one installed

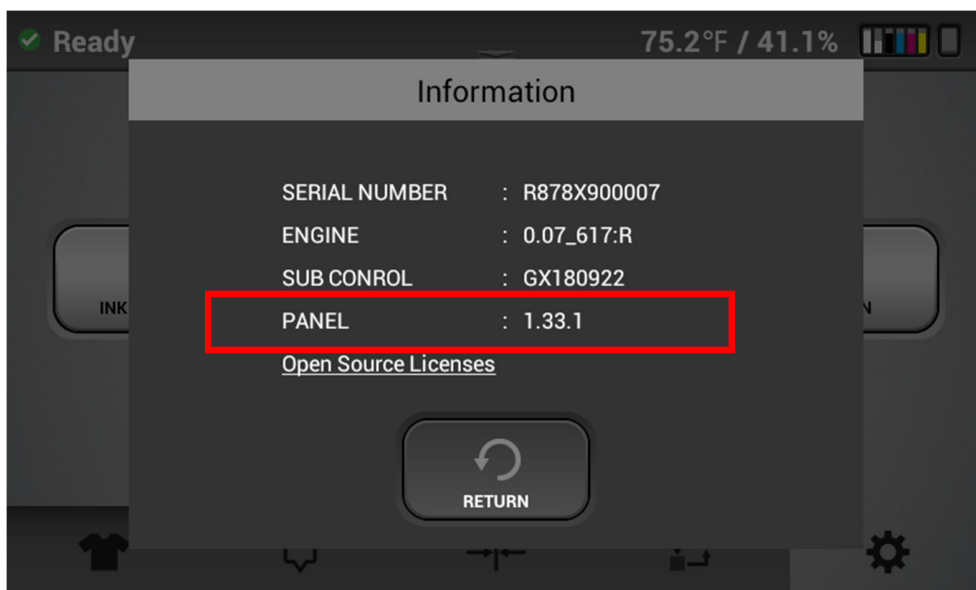

10 About Open Source Software License

ZLib

Copyright (C) 1995-1996 Jean-loup Gailly and Mark Adler

This software is provided 'as-is', without any express or implied warranty. In no event will the authors be held liable for any damages arising from the use of this software.

Permission is granted to anyone to use this software for any purpose, including commercial applications, and to alter it and redistribute it freely, subject to the following restrictions:

1. The origin of this software must not be misrepresented; you must not claim that you wrote the original software. If you use this software in a product, an acknowledgment in the product documentation would be appreciated but is not required.
2. Altered source versions must be plainly marked as such, and must not be misrepresented as being the original software.
3. This notice may not be removed or altered from any source distribution.

Jean-loup Gailly Mark Adler

gzip@prep.ai.mit.edu madler@alumni.caltech.edu

11 Troubleshooting Guide

Issue/ Error	Possible reason	Countermeasure
1) Fuzzy blurry prints	Table height is to low	For most T-shirts the indicator below the height adjustment knob on the table should be set to 0 or near 0. The best printing is achieved when the print head is 1.5mm away from the printing surface
	Too much ink (oversaturated) causing bleeding (mostly for white or light shirts without pretreat	Check the settings in the RIP - especially rendering intent (perceptual is default and should be used in most cases). Make sure the ink set and profiles are correct. Profiles meant for 600 x 600 dpi will have to much ink if 1200 X 1200 dpi output is selected
	Nozzle check shows all nozzles but some areas show deflection. (See section 6.1 Nozzle check)	perform head clean or cleans and recheck nozzle to see if the deflection is gone
	For dark shirt with a white under base- poor pretreat - Not enough pretreat can make the white can CMYK areas of print to appear dull or fuzzy. Especially if a section of the print appears sharp and another section appears dull or fuzzy	See section 5 user manual
	Head alignment is off	Perform head alignment procedure (see section 7.1) make sure to rule out the above reasons before this adjustment
2) Horizontal banding - thin horizontal lines across the entire shirt	Nozzles missing - if nozzle check shows some nozzle missing	Perform head cleans until the CMYK nozzles are 100%
	Nozzles all there but some showing minor deflection	Check table height - the effect of any deflection will be exaggerated if the printing surface is too far away from the head - For most T-shirts the indicator below the height adjustment knob on the table should be set to 0 or near 0. The best printing is achieved when the print head is 1.5mm away from the printing surface
		Perform head cleans until the deflection is reduced
	Nozzles 100% and little to no deflection	Perform table alignment procedure (see section 7.2)

<p>3) Horizontal banding - thick horizontal lines across the entire shirt</p>	<p>Nozzles 100% - appears in solid colors of dark or gray - bi directional banding - has to do with the colors laying down in different sequence depending on which direction the carriage is traveling</p>	<p>Uncheck the bi directional box in the RIP.</p>
	<p>Nozzles 100% - appears in solid colors - the color is inconsistent in the scanning direction of the carriage. This is caused by the different drops of CMYK not combining consistently</p>	<p>This can show in Speed Quality mode for CMYK - Print in Fine Quality mode for CMYK - if still persists - print in 1200 X 1200 dpi (Kothari RIP)</p>
<p>4) Several nozzles out – improves not at all or just a little with head normal and strong head cleans</p>	<p>During an initial ink fill - air has been introduced to the head or after a head clean cleaning fluid or air was inadvertently pushed into the head by the cleaning applicator</p>	<p>Let the printer sit overnight which will give the air a chance to settle – after the nozzle should be good</p>
<p>5) Dark shirt prints look dull</p>	<p>White nozzles 100 % or near 100%. - Inadequate amount of pretreat on shirt - this can cause the white ink to mostly sink into the shirt</p>	<p>Increase the amount of pretreat being sprayed on the shirt</p>
	<p>White nozzles 100 % or near 100% but look dull. - White ink has settled</p>	<p>If the white cartridges have not been agitated per instructions - will need to agitate the white ink cartridges for 2 minutes. Then perform 3 to 4 strong head cleans - this will replace most of the settled ink</p>
	<p>Missing many nozzles on one or both white heads</p>	<p>Perform head cleans to recover the nozzle to 100% or near 100%</p>
<p>6) Light shirt looks too dull</p>	<p>Nozzle is 100% - Wrong output profile is selected</p>	<p>If printing in 600 X 600 Dpi and using a profile meant for 1200 X 1200 DPI then the shirt will look dull</p>
<p>7) Cartridge reads 0% but was just at a high % (example 65%) at the previous operation. (before printing or before cleaning)</p>	<p>Temporary loss of Comm caused cartridge reading error</p>	<p>Pull out the cartridge that reads 0%. The status should change to NC and the cartridges not loaded message will appear in the status bar. Put the cartridge back in and the % reading should go back to normal. If the % still reads 0 after reinserting the cartridge then turn the printer off and turn it back on and the cartridge will read correctly</p>

Maintenance Requirements

IMPORTANT! Perform the following to prevent the risk of printer failure:

- Always keep the machine power on. If it is necessary to turn off the machine for over 12 hours then fill the printer with cleaning fluid.
- Do not leave the machine with an empty ink cartridge installed in it, or with any pending errors or service call messages.
- Always keep spare ink on hand. If you do not have replacement ink, fill the printer with cleaning fluid to prevent the risk of damage to the carriage.
- If white ink clogging occurs frequently, please increase the frequency of cleaning the white ink. Refer to the user manual for details.
- Do not move the table back and forth by hand. It can cause printer failure.

Maintenance Schedule

Always perform the following maintenance schedule. These are minimum guidelines. More frequent cleaning may be necessary depending on machine usage. Please refer to the user manual for detailed instructions.

[Daily]

Shake White Cartridge

[Weekly]

Clean the Maintenance Unit and the Flushing Box

Clean the Nozzle Cover

Clean the Guide Rod and the Encoder Strip

Installation/Operation Environment

Temperature: 59°F/15°C - 90°F/32°C

Humidity: 45% - 80%RH, non-condensing humidifier recommended

Attention

Ensure the garment lies flat and is smooth.

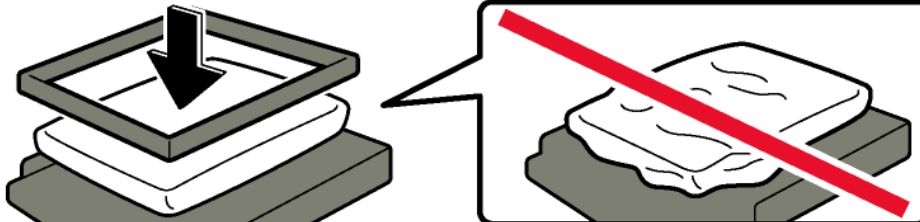

Position the table close to the print head.

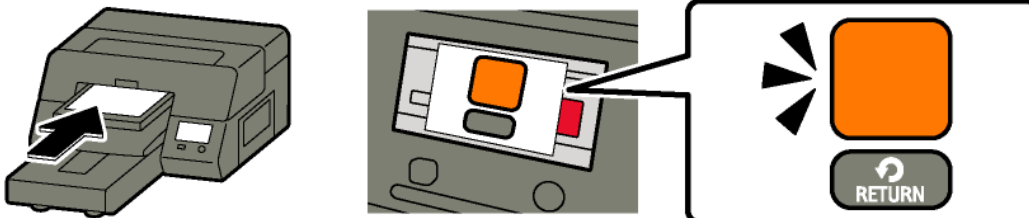

If the warning "Obstacle Detected" appears, slowly turn the dial to the left until the orange indicator turns white. Do not lower the table any further.

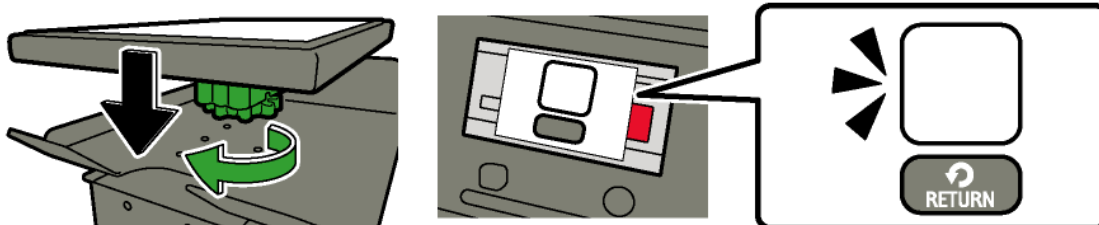

Press [Return] and then [SET]

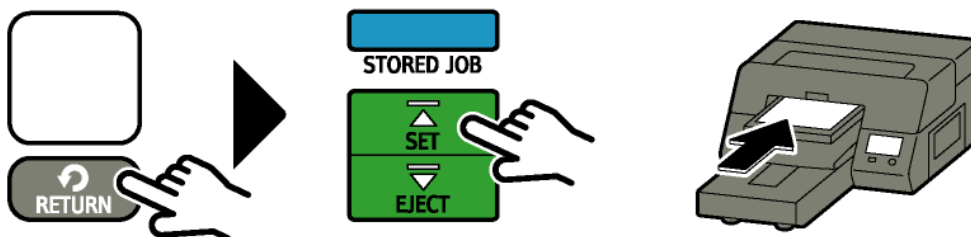

⚠ IMPORTANT!

Do not lower the table more than is necessary to stop the "Obstacle Detected" warning. Too big a gap may cause misting and printer failure.