

router. raiZer

RZ 100

Installation Instructions:

TO AVOID CONFUSION DURING INSTALLATION
follow steps 1 through 5 listed below

- Step 1.** Remove pages 2 through 7 from book
- Step 2.** Remove your router install pages
- Step 3.** Return extra pages to box
- Step 4.** For smoothest plunging action purchase STP® before installation. SEE PAGE 2
- Step 5.** See page 3 for parts diagram

Router Install Pages

- Craftsman 27505-27506-27510-27511 -- (8-9-10)**
- De Walt DW 625 & ELU 3337- 3338-3339 -- (11-12-13)**
- De Walt DW 621 -- (14-15-16)**
- Freud FT 2000 -- (17-18-19)**
- Hitachi M12V -- (20-21-22)**
- Hitachi TR12 -- (23-24-25)**
- Makita 3612 Series -- (26-27-28-29)**
- Porter Cable 6931 Plunge Base -- (30-31-32-33-34-35)**
- Porter Cable 7538 / 7539 -- (36-37-38)**
- Porter Cable 7529 / 8529 -- (39-40-41)**
- Ryobi RE 600 -- (42-43-44)**
- Ryobi RE 500 -- (instructions available on our website)**

For Parts or Installation Assistance Contact

router TECHNOLOGIES INC. phone: 1-866-266-1293
 fax: 1-515-266-2122
 2729 Delaware Ave, Des Moines, IA. 50317

Visit our Website @
www.routertechnologies.com

© 2000-2005 Router Technologies
 All Rights Reserved

Craftsman is a registered trademark of the Sears, Roebuck and Co. Corporation
 DeWalt is a registered trademark of the Black and Decker Corporation
 ELU is a registered trademark of the A.G. Corporation
 Freud is a registered trademark of Freud USA Ltd
 Hitachi is a registered trademark of the Hitachi Ltd Corporation
 Makita is a registered trademark of the Makita Electric Works Corporation
 Porter Cable is a registered trademark of the Porter Cable Corporation
 Ryobi is a registered trademark of the Ryobi Ltd Corporation

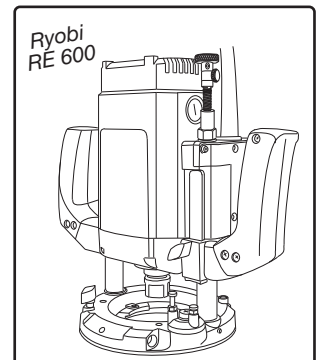
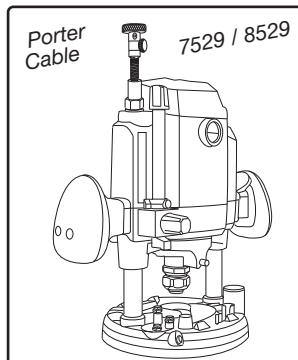
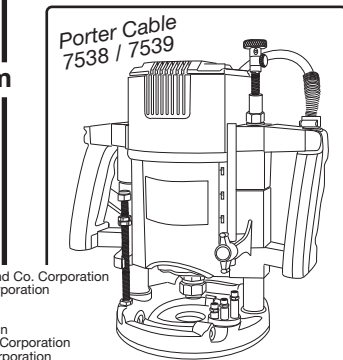
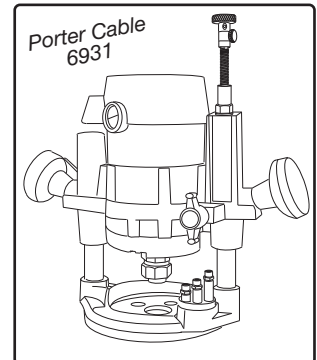
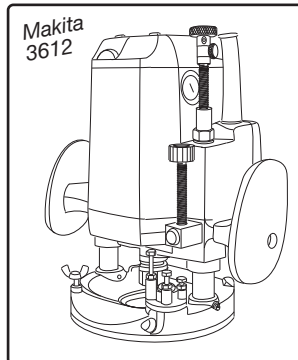
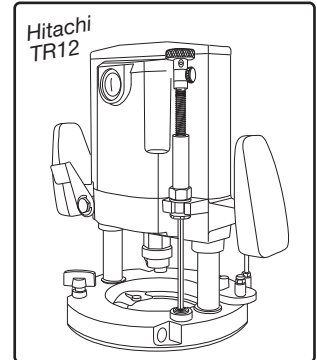
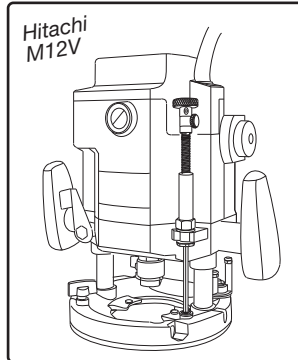
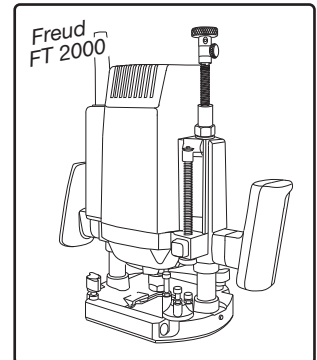
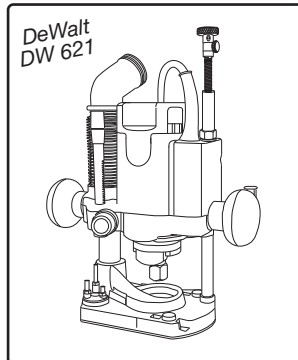
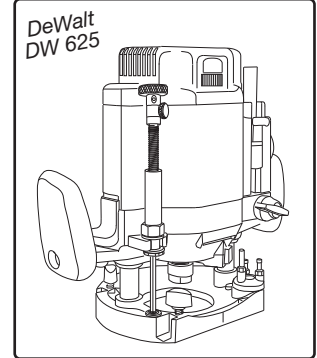
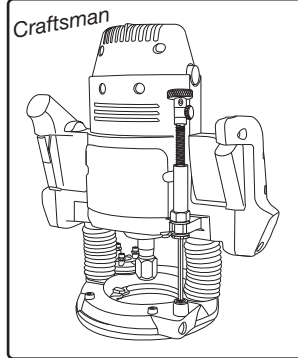

METRIC EQUIVILANTS FOR INTERNATIONAL CUSTOMERS

Note: The following metric drill bit or wrench sizes may be substituted for all operations other than drilling hole for #30 Dust Cover Insert.

1/8" = 0.125"	3.20mm = 0.126"
3/32" = 0.093	2.4mm = 0.094
5/32" = 0.156"	no metric equivalent, this hole must be drilled to 5/32"
7/32" = 0.218"	5.5mm = 0.216"
5/16" = 0.312"	8.0mm = 0.315
21/64" = 0.328"	8.3mm = 0.326" or 8.5mm = 0.334"
1/2" = 0.500"	12.8mm = 0.503 or 13mm = 0.511
11/16" = 0.687"	17.5mm = 0.689" or 18mm = 0.708"
3/4" = 0.750"	19.0mm = 0.748

30 Dust Cover Insert must be 0.500" use a 12.5mm bit and sand hole to fit cover. 12.5mm = 0.492"

This instruction manual covers several different makes and models of plunge routers. The instructions are written for a person with some mechanical ability. If you understand the parts and operation of a plunge router, installing the Router Raizer is not difficult. Before beginning installation compare the illustrations and photos to your router, original subbase or router table insert plate. Understand the location and function of both original and Router Raizer parts. Keep all spare parts, instruction manual and templates for future reference.

Responsibility of the Owner

Important: Read, understand and follow instructions to avoid personal injury.

1. The responsibility of the owner is to follow the instructions, cautions, and warnings bellow and in the instructions
2. Know and understand the location of both original and Router Raizer parts.
3. Follow all the assembly instructions carefully.
4. Correctly adjust the components making sure the plunge action is smooth and plunge lock operates properly.
5. Carefully read and follow all notes, tips, cautions and warnings.
6. Make sure all operators of the Router Raizer know how to correctly use it.

Caution: Before and during installation of Router Raizer make sure power switch is in the off position and tool is disconnected from power source to avoid accidental starting of the tool which may result in personal injury.

Caution: Always make sure router power switch is in the off position and disconnected from power source before and during any adjustments to the router or Router Raizer.

Warning: Never remove or reinstall #31 dust cover or make any depth of cut adjustments from either end of #1 mainshaft until router power switch is off, cutting tool has completely stopped rotating and tool is disconnected from power source.

Caution: Always secure plunge lock before and during routing operations.

ROUTER TECHNOLOGIES LIMITED TWO YEAR WARRANTY

Router Technologies warrants the Router Raizer to be free from defects in material and workmanship for a period of Two (2) Years from the original date of purchase to original owner. Our responsibility under this warranty is to replace, at no cost, any part which upon inspection at our facility is found to be defective in either material or workmanship. This warranty does not imply that the product is fit for a particular use or application, this warranty does not apply to parts which have been modified, altered, misused, damaged by improper storage. It also does not cover loss of parts during use, or mechanical adjustments which are covered in the instruction manual. In no event shall Router - Technologies be liable for any indirect, incidental or consequential damages from the sale or use of the product. This disclaimer applies both during and after the term of the warranty.

This warranty is your only remedy and parts are to be returned prepaid to our facility for inspection at Router Technologies, 2729 Delaware Ave, Des Moines, IA. 50317.

This warranty gives you specific legal rights, and you may have other rights which may vary from state to state. Any legal actions must be brought in Polk County Iowa.

FULL SIZE PARTS DIAGRAM ON BACK OF THIS PAGE (PAGE 3)

1. Remove Pages From Book

Before installation please remove the pages required for your router from this book. *Failure to do so can result in referring to the wrong page, confusion and damaged parts!*

2. Installation

The Router Raizer is designed to make the plunge router easy and enjoyable to adjust . It may appear to be complex and difficult to install, but the plunge router is an easy tool to disassemble and reassemble. Allow approximately 1½ hours for installation. For technical assistance call toll free 1-866-266-1293

3. Multiple Parts (After installation you will have extra parts)

The Router Raizer is a universal kit containing many parts you will not install into your router. Each instruction page lists the parts required for installation into that router. We advise keeping and storing all the extra parts and instructions.

4. STP® for Lubricating The Plunging Action (All Plunge Routers)

For maximum performance and smoothest plunging action all plunge posts require a light film of lubrication. We only recommend using STP® MOTOR OIL TREATMENT.

Before beginning the installation please purchase a bottle of STP®. Apply a light film to the posts and inside the post bushings just before reassembling the router.

1. Install the Router Raizer components into the base and motor housing of the router.
2. Before reinstalling the motor housing onto the base, use a Q tip, brush or little finger to apply a film of STP® to the inside of both post bushings and the outside of both plunge posts.

NOTE: STP® on the posts can attract dust, but the lubricating properties are not affected. Periodically wiping the posts clean and reapplying STP® to the posts only will keep the router operating smoothly.

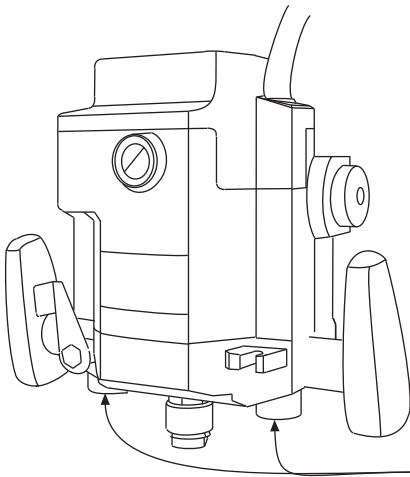

Post Bushings Apply light film on the inside surface of both post bushings.

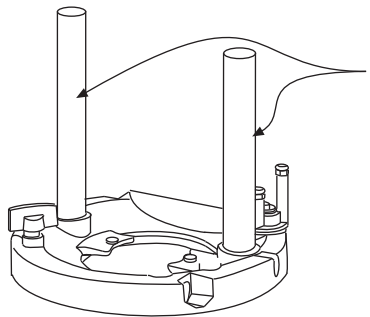

Plunge Posts Apply light film to the outside surface of both plunge posts.

5. Plunge Post Boots

Some plunge routers use rubber boots to seal the posts from dust and debris.

We recommend leaving these boots off when reassembling the router, and using the above lubrication and maintenance to keep the router operating smoothly.

Plunge Post Boots

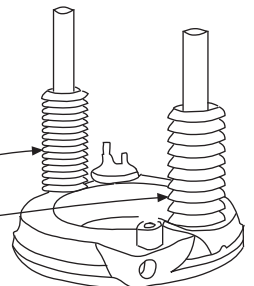

To avoid confusion during installation remove this page and router being installed pages, return others to box.

RZ 100 Parts Diagram

Parts Shown Full Size

Note: Actual mainshaft length 12 1/4"

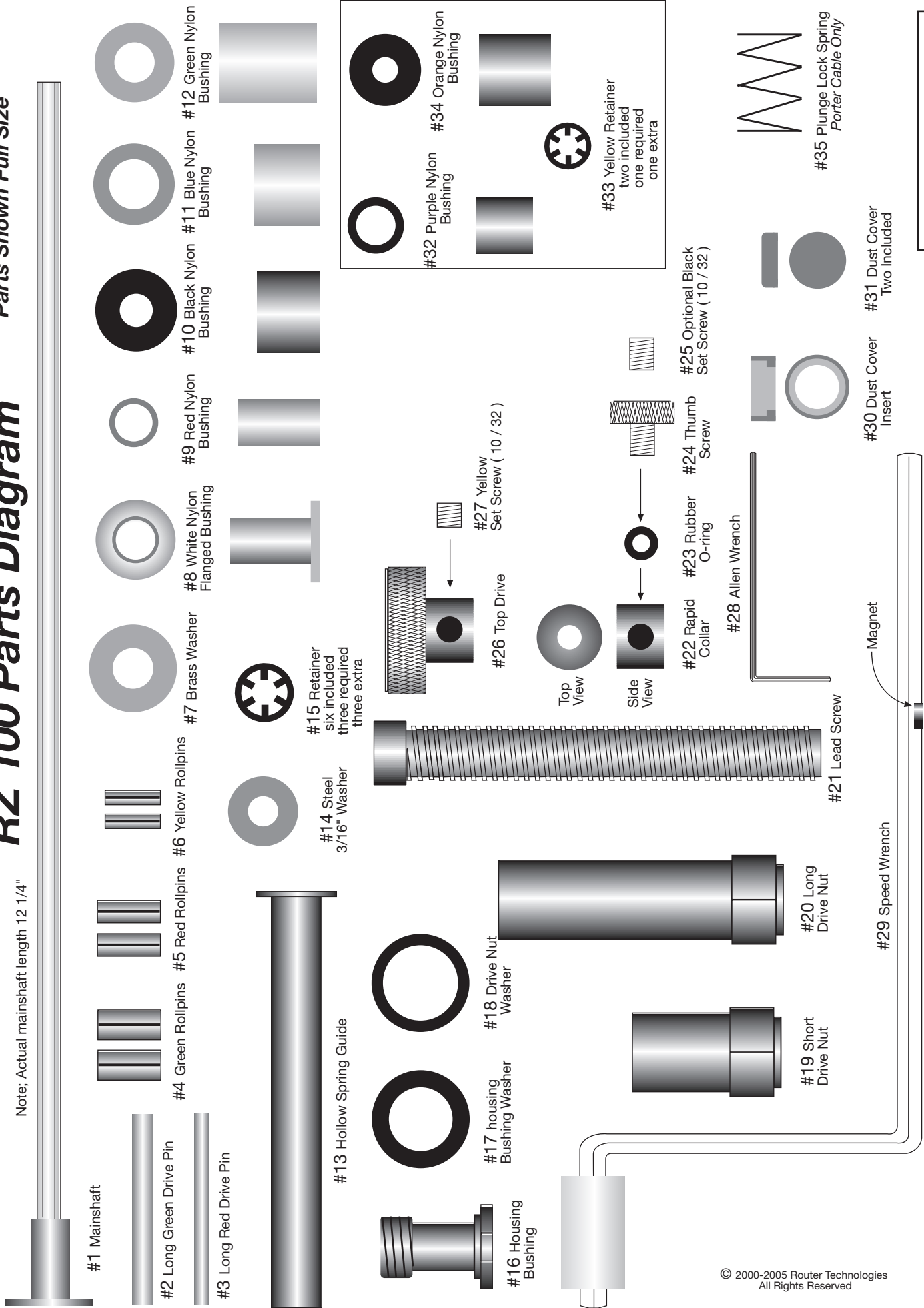

Caution: Before and during installation of Router Raizer make sure power switch is in the off position and tool is disconnected from power source to avoid accidental starting of the tool which may result in personal injury.

Use this pin to simplify locating the Router Raizer access hole required through the original subbase or router table.

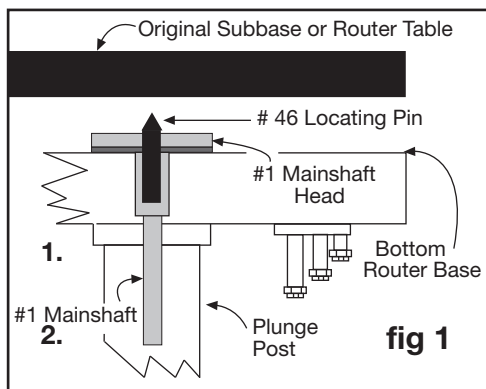

Locating Hole in Original Subbase

Using fig 1 support router upside down on bench and place locating pin into bottom of #1 mainshaft head. Secure subbase to router base gently tightening screws. Using a hammer gently tap the subbase over the pin. Remove subbase and drill hole on center punch mark using the Router Raizer template instructions.

Locating Hole in Router Table

If your router table is already drilled to mount the router, use above step using table or insert plate in place of original subbase.

If your router table or insert plate have not been drilled use the provided paper template or original subbase to first locate and drill the router mounting holes, then use #46 locating pin to drill Router Raizer access hole.

NOTE: For highest accuracy, the locating pins point should just project above the #1 mainshaft head. Shorten the pin to desired length by securing pointed end of locating pin in jaws of cordless or electric drill. Grind but end of pin off and debur ground end. Cool pin before removing from chuck jaws!

Preparing and Drilling Router Table Top

- Determine if the head of the #1 mainshaft protrudes above the base of your router (shown Fig 1 above)
 - If the head of the #1 mainshaft does not protrude above the base of your router, use #46 locating pin then drill a 1/2" hole through table top or insert plate and install #30 dust cover insert as shown at bottom of page 5
 - If the head of the #1 mainshaft protrudes above the base of your router clearance is required for the head of #1 mainshaft to rotate freely. Select either method #1 or #2 (page 4 and 5) and follow instructions for selected method.

METHOD #1 (Drilling 3/4" Pocket in Back of Insert Plate requires min 3/8" thick plate)

- Use the #46 locating pin to mark the back of the insert plate or table top.
- Center 1/8" drill bit on locating pin center mark and drill completely through plate or top.
- CAUTION 3/4" pocket must be drilled on the bottom side of plate or table top. (fig's 2 & 3)**
From bottom side, center 3/4" forstner bit on 1/8" pilot hole and drill pocket **no deeper than 3/32"**
- From top side, center 1/2" drill bit on 1/8" pilot hole and drill through into 3/4" pocket.
- From top side, press #30 dust cover insert into 1/2" hole until flush with top surface. If insert is loose in 1/2" hole, place a drop of super glue from bottom side around edge of the insert ring. (fig's 3 & 4)

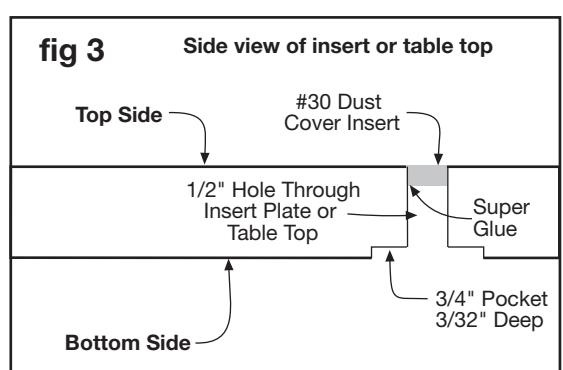
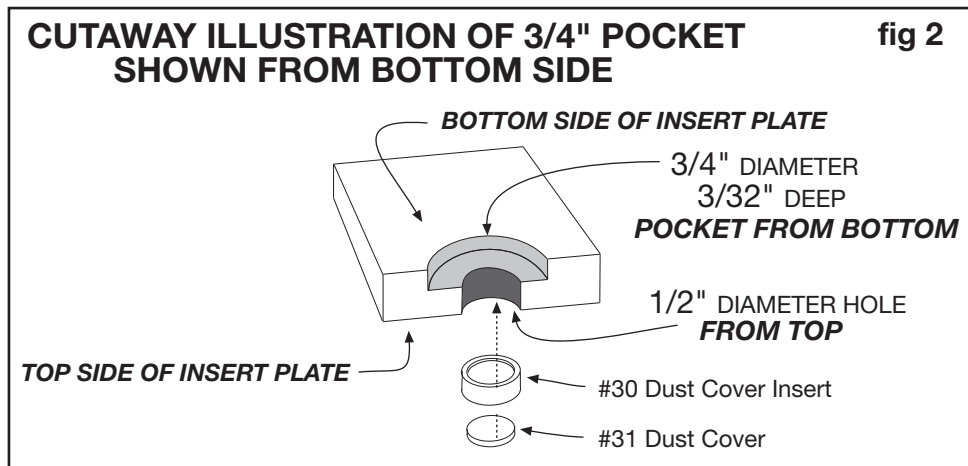
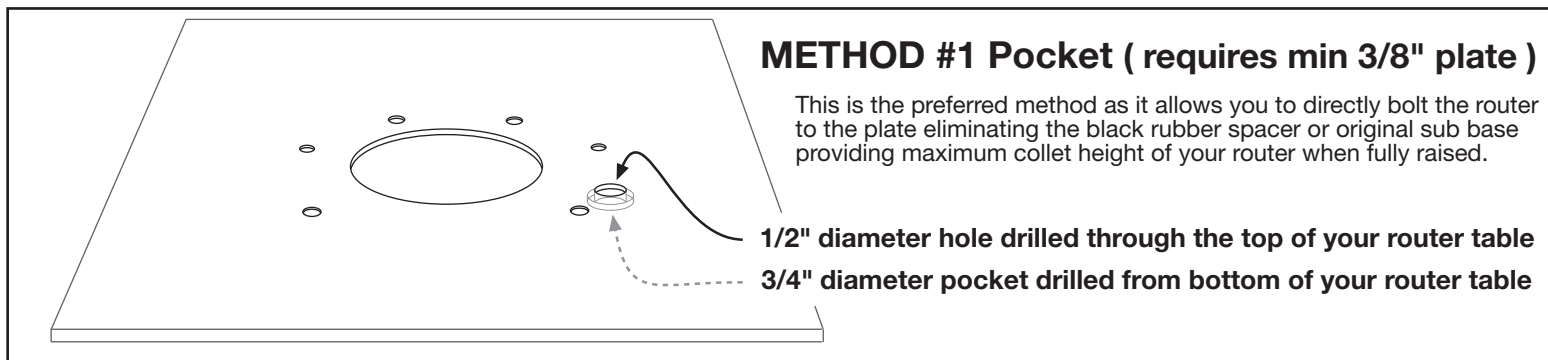

NOTE: All installations require a 1/2" diameter hole drilled through the top of your router table top or insert plate to accept the #30 dust cover insert shown bottom of page.

If method #1 drilling pocket is not possible, a spacer must be placed between the router and table top providing space for #1 mainshaft rotation.

METHOD #2 (A) Black Rubber spacer

Some table tops and steel insert plates do not allow cutting the pocket from the back side. An 8" X 8" black rubber spacer is provided to cut out and place between the router and the table top or insert plate.

1. Place the rubber spacer onto base of your router with the pre-punched 3/4" hole centered on the #1 mainshaft head.
2. Use a utility knife or raiser blade to cut out the center hole and router mounting holes. **Note:** Mounting holes can be cut square and rounding outside of spacer is optional. This method may require slightly longer mounting screws.

METHOD #2 (B) Routers Original Sub Base

Preferred method for steel insert plates or installations where the router is secured to the plate using a pre designed clamping system. This method may also be used in place of method #2 (A)

1. Use #46 locating pin, then drill 3/4" hole through original sub base and secure subbase to router with original screws.

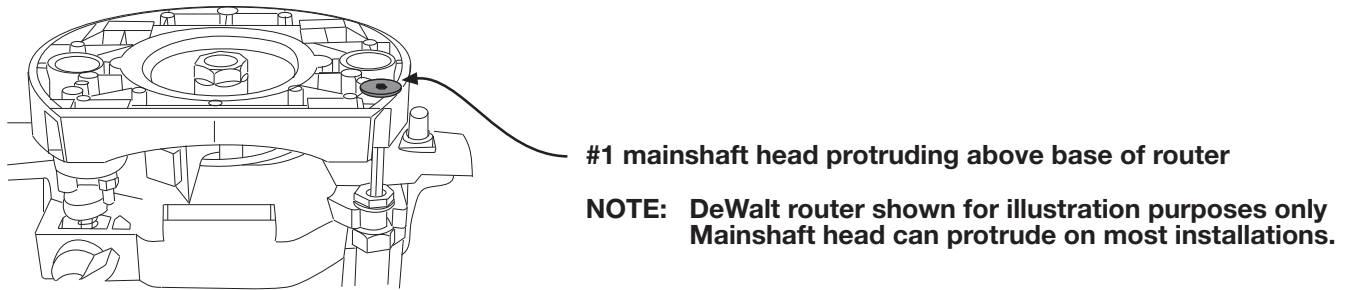
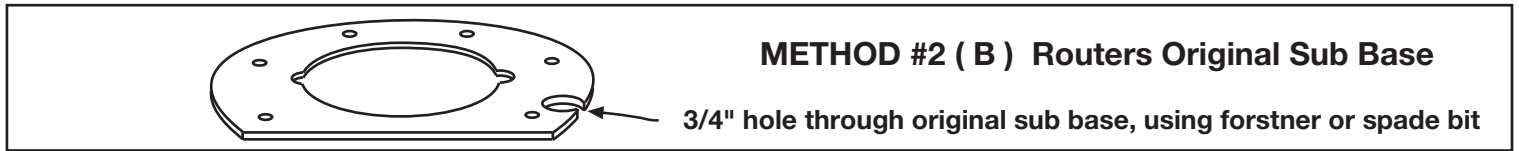
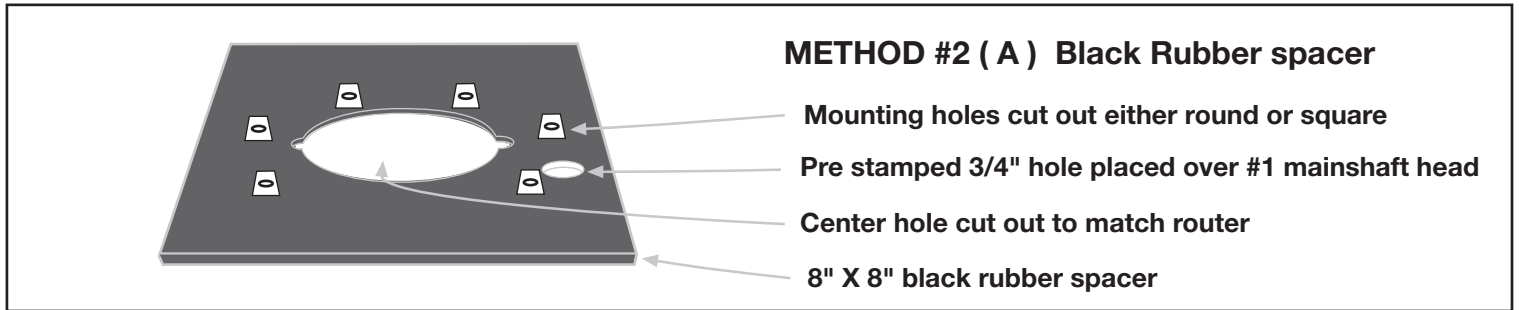

Installing #30 Dust Cover Insert and #31 Dust Cover

1. Using (fig 7) select #30 dust cover insert (1/2" dia, X 3/16" tall, turned aluminum ring) and #31 dust cover (3/8" dia. X 1/8 thick stamped steel plug) From top of insert plate, press #30 cover insert into the 1/2" Router Raizer access hole until flush.

Tip: If cover insert fits loosely, secure with drop of Super Glue® or Crazy Glue®.

2. Mount router to insert plate and install into table

3. Place #31 dust cover into #30 dust cover insert. Using (fig's 1 & 2) remove #30 dust cover with magnet on back of #29 speed wrench. With dust cover on speed wrench, insert wrench to make adjustments. To reinstall dust cover, place cover into insert and slide wrench away. **Caution: Remove dust cover with speed wrench before removing router from table or cleaning table with vacuum sweeper.**

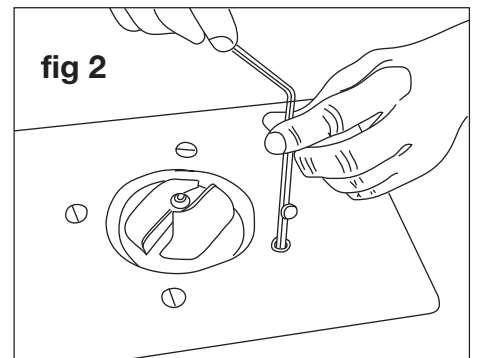
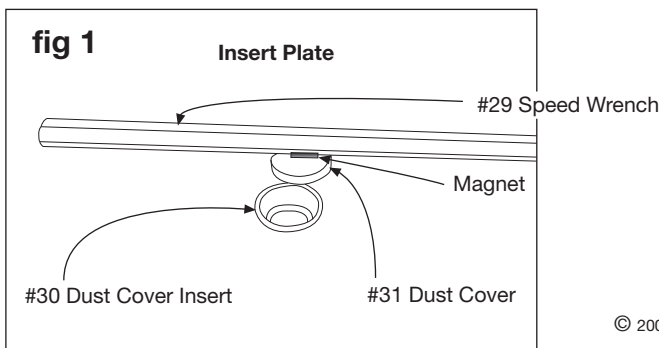
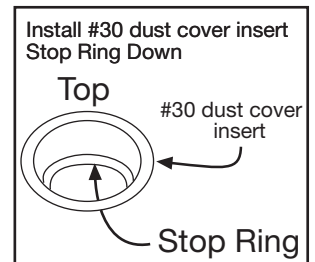

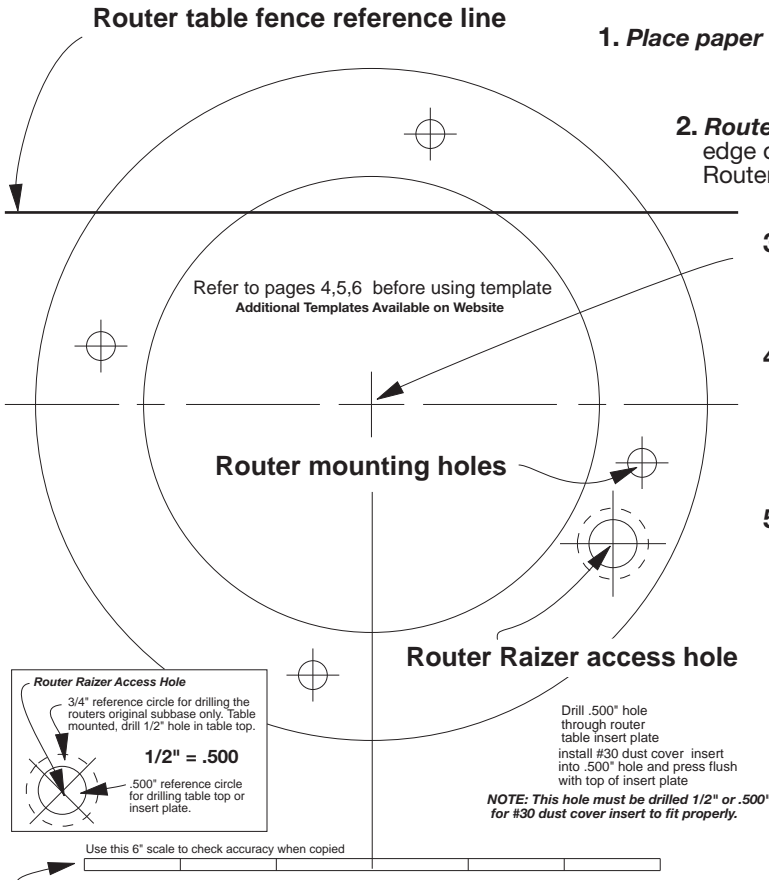

1. Place paper template lettering up onto top side of router table or inset plate.

2. Router table fence reference line. Setting this line parallel with the back edge of the router table or inset plate positions the router so the Router Raizer access hole will be drilled out in front of the fence.

3. Center cross hairs. Accurately center this point in the hole of the router table or inset plate, using a pencil compass or tape measure. Tape in place and recheck before drilling holes.

4. Router mounting holes. For highest accuracy place the routers original subbase over the templates router mounting holes and tape subbase down. Use a Vix bit, center punch or drill bit to transfer holes to the router table or insert.

5. Router Raizer access hole. Use page 4 and # 46 locating pin to accurately mark the access hole location

WARNING: IF 3/4" POCKET IS REQUIRED PAGES 4 & 5. DO NOT DRILL 3/4" HOLE COMPLETELY THROUGH THE TABLE TOP OR INSERT PLATE. A 1/2" HOLE IS REQUIRED IN THE TOP TO ACCEPT THE #30 DUST COVER INSERT.

IF ORIGINAL SUBBASE IS USED BETWEEN ROUTER AND TABLE PAGES 4 & 5. USE #46 LOCATING PIN THEN DRILL 3/4" HOLE THROUGH ORIGINAL SUBBASE.

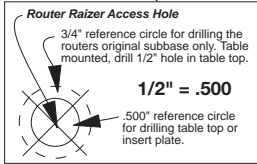

Drill .500" hole through router table insert plate install #30 dust cover insert into .500" hole and press flush with top of insert plate

NOTE: This hole must be drilled 1/2" or .500" for #30 dust cover insert to fit properly.

Use this 6" scale to check accuracy when copied

6" Scale. If template is copied or downloaded from web site, use this scale to accurately check template size.

Troubleshooting

Problem	Cause	Solution
Router Raizer will not raise or lower the router	#19 or #20 Drive nut loose	The drive nut cannot rotate, Retighten the drive nut on router.
	Router plunge posts dry	Clean posts and lubricate with STP® MOTOR OIL TREATMENT
Router Raizer Speed Wrench turns hard	Pocket in table top or insert plate not counter sunk deep enough	Check pocket depth and deepen if necessary. #1 mainshaft head must rotate freely.
	#21 lead screw has no lubrication	Re lubricate using supplied red grease or heavy wheel bearing grease.
	Router plunge posts dry	Clean posts and lubricate with STP® MOTOR OIL TREATMENT
Router Raizer will not raise router high enough	Turret stop on router improperly set	Locate rotating turret stop on base of router and adjustable stop directly above. Adjustable stop must be retracted as high as possible. Turret stop must be rotated so shortest post is under adjustable stop.
	Reached maximum plunge depth of router	All plunge routers have a predetermined plunge stroke, the Router-Raizer will not increase this stroke. With router fully compressed-check amount of plunge post still visible. 1/16" to 1/4" post should be visible. If more than 1/16" to 1/4" of post is visible, Call 1-866-266-1293 Addition of a collet extension is required to safely run some bits.
Router becomes harder to raise and lower	Router plunge posts dry	Clean posts and lubricate with STP® MOTOR OIL TREATMENT

Caution: Always make sure router switch is in the off position, and tool is disconnected from power source when performing maintenance or making any adjustments to either the router or height adjustments to avoid accidental starting of tool which may result in personal injury.

Using in a Router Table

Dust Cover Insert and Dust Cover

The dust cover insert and dust cover allow easy adjustment access to the Router Raizer mainshaft and restricts dust and debris infiltration during use. A small magnet is recessed into speed wrench handle to remove and hold the dust cover during adjustments.

1. Removing dust cover: Using (fig 1) place #29 speed wrench over #31 dust cover, lift speed-wrench to remove dust cover. Leave dust cover on wrench while making height adjustments.

2. Replacing dust cover: Position speed wrench with dust cover over the insert, press cover into insert and swipe wrench away leaving the dust cover in the insert.

3. Always remove #31 dust cover before removing router and insert from table. Or cleaning table with vacuum sweeper
Warning: Never remove the dust cover while the router is running. Always wait until the bit has stopped spinning.

4. Rapid collar positioning: The rapid collar is for hand held use only, for router table use position collar against retainer clips and top drive (fig 2). Secure with #24 thumb screw or optional #25 black set screw.

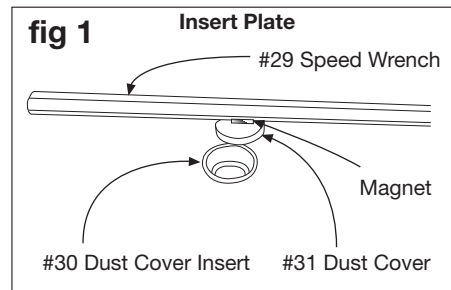

Using Handheld

When used hand-held the hex shaped #1 mainshaft provides a constant engagement of the Router Raizer mechanism, allowing easy height adjustments while retaining original plunge capabilities and all other original functions of the router.

1. Height adjustments can be made from either end of the router. To adjust from the base, engage #29 speed wrench into the head of #1 mainshaft. To adjust from the top, engage #29 speed wrench into the top of #26 top drive. The knurled #26 top drive also allows adjustments by hand.

The #24 thumb screw and #22 rapid collar allow positioning the cutter to height. bypassing multiple revolutions of the speed wrench

1. (fig 2) Illustrates compressing the plunge router with rapid collar locked in the router table position. Insert #29 speed wrench into #26 top drive, or lay router on its side and insert #29 speed wrench into bottom of #1 mainshaft. Rotating the speed wrench will thread #21 lead screw in or out of the drive nut, compressing and un compressing the router.

2. (fig 3) Illustrates compressing the plunge router with the rapid collar. Thread #21 lead screw into the drive nut leaving approx 1/2" exposed threads, the router will be un compressed. Secure desired router bit in collet, stand router upright hand plunge to approx desired depth lock plunge lock lever. Release #24 thumb screw and drop rapid collar into contact with #21 lead screw. secure thumb screw and release plunge lock lever. Insert #29 speed wrench into #26 top drive, lay router on its side and insert #29 speed wrench into bottom of #1 mainshaft and adjust to required depth. Re lock plunge lock before routing. When done release thumb screw and router will quickly return to the un compressed position for easier bit removal.

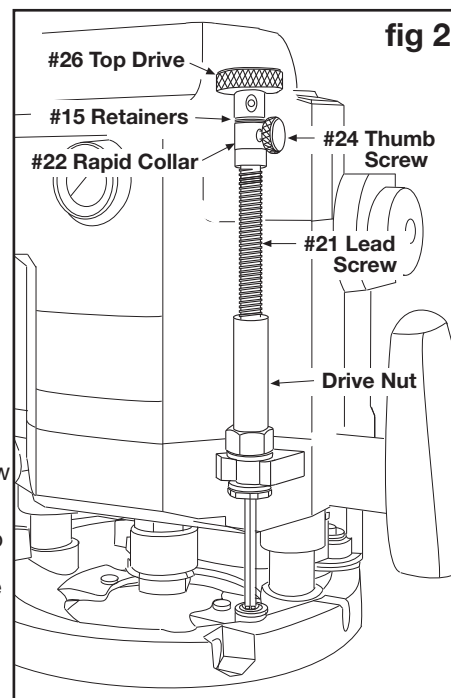

Caution: #22 rapid collar is not designed to maintain cutter height during routing operations. Always secure plunge lock before and during all routing operations.

4. If #24 thumb screw will not provide enough pressure to secure #22 rapid collar, replace thumb screw with #25 optional black set screw and #28 allen wrench.

Direction of Rotation for Adjustment

Adjustments from #26 top drive:

Clockwise rotation Decreases depth of cut. Counterclockwise rotation Increases depth of cut.

Adjustments from #1 Mainshaft Head :

Clockwise rotation Increases depth of cut. Counterclockwise rotation Decreases depth of cut.

One complete rotation of the speedwrench, raises or lowers the bit 1/16"

Caution: Always secure plunge lock during routing operations.

Transporting or Storing Router

To prevent damage to the #1 mainshaft and #21 lead screw, adjust the lead screw leaving 1/2" threads exposed. Grasp router handles, release plunge lock, advance router up until lead screw rapid collar and retainers are all in contact, engage plunge lock.

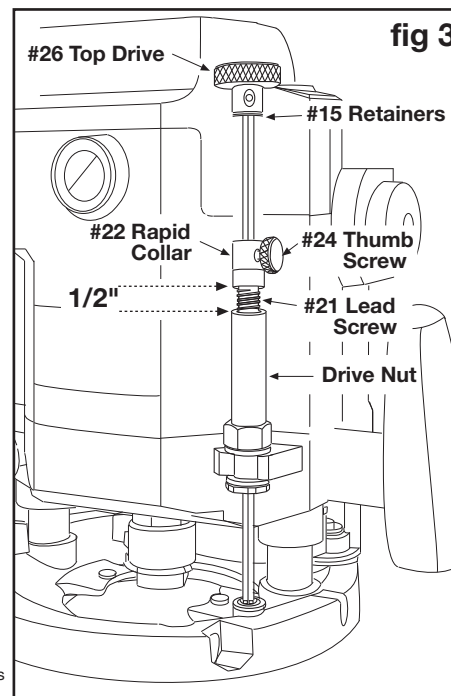

NOTE: Check Off Each Step When Done

Ryobi RE 600

Tools Required: 11/16" wrench, phillips & straight screwdrivers, hammer, 1/2" drill bit, drill, hacksaw

Router Raizer Parts Required: (see page 1) #1, #3 #6, #7, #9, #12, #13, #14, (three #15) #16, #18, #19, #21, #22, #23, #24, #26, #27, #28, #29, (#30,#31, #46 for router table installation)

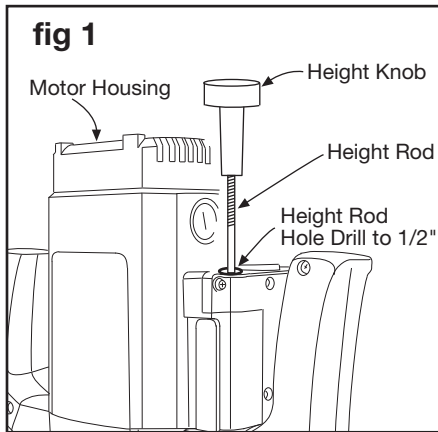

1. Cut #1 mainshaft to 11" overall length and debur cut end. Set aside to install later.

Preparing Motor Housing

1. Using (fig 1) Engage plunge lock. Remove height knob by unscrewing from height rod.
2. Stand router upright, grasp both handles, release plunge lock and lift motor to clear plunge springs. Remove and set aside plunge springs with the spring guide in top of each spring, (fig 2).
3. Select a 1/2" drill bit and drill. Using (fig's 1 & 3) drill the motor housing height rod hole to 1/2".
4. Using (fig 3) select #16 housing bushing, #18 drive nut washer, #19 short drive nut. Remove power switch side handle secured with three phillips screws. Remove the power switch variable speed cover secured with five phillips screws. Place #16 housing bushing into remaining half of drilled height rod hole. Place #18 drive nut washer onto #16 bushing, and thread #19 short drive nut onto #16 housing bushing. Tighten using 11/16" wrench.

NOTE: #18 washer must fit on small shoulder #19 nut compare to inset A (fig 3)

5. Check that variable speed circuit board is located properly in housing slots, Position switch cover and tap into place, loosen #19 short drive nut if necessary. Replace and tighten five screws. Retighten #19 short drive nut, replace handle.

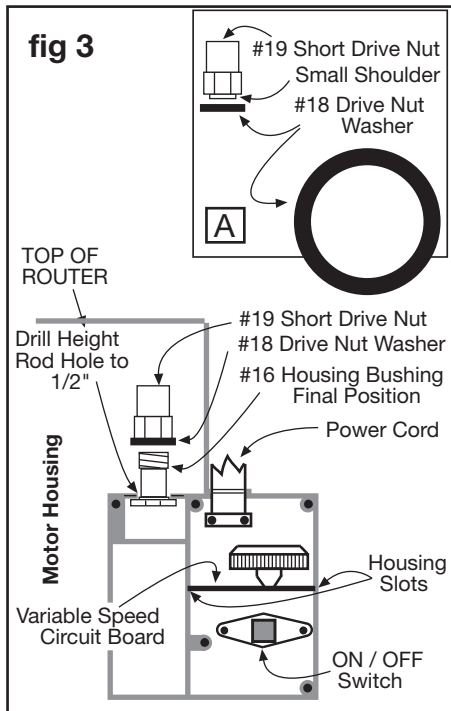
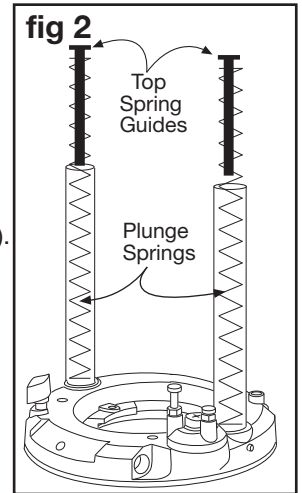

Preparing the Base

1. Select: hammer, phillips screwdriver, #3 red drive pin, #6 two yellow roll pins, Using (fig 4) remove and set aside subbase. Line #3 red drive pin up with the height rod roll pin and drive roll pin from base. **Note:** this rollpin can drive out hard, and may require re-straightening of #3 drive pin. From bottom of base, drive height rod out of post, leaving the original steel bushing in place. **Note:** Height rod is pressed into steel bushing and can require force to remove, **Store height rod, rod pin, and height knob.**

2. Align the roll pin holes through the base, post and original steel bushing. If necessary use a pointed tool to align.

Note: the following step secures the post and original steel bushing to the base using two roll pins. Both roll pins are installed from the outside of the base, and cannot extend into the original steel bushing bore shown dotted lines (fig 5) If #6 yellow roll pins extend into bore, insert a screwdriver into bottom of bushing bore and push pins flush.

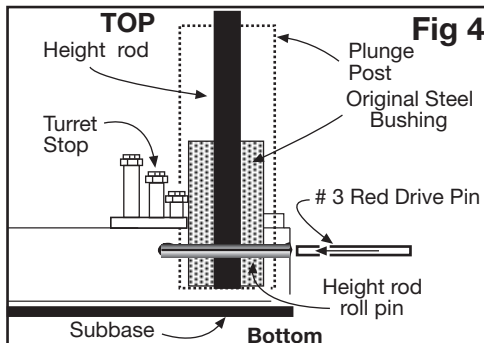

3. Select two #6 yellow roll pins and #3 red drive pin. Using (fig 5) place one yellow roll pin into hole, drive in until flush with outside of base. Align #3 red drive pin with roll pin, and drive through original steel bushing to opposite side. Check and adjust this roll pin to be flush inside bushing bore. Start second yellow roll pin into base, drive in leaving 1/16" exposed. Check bore and adjust if necessary.

4. Select #9 red nylon bushing. Using (fig 5) drive bushing into bottom of original steel bushing until flush. **Tip:** sand slight chamfer on top edge of #9 red bushing to ease installation.

5. Select #1 mainshaft, #7 brass washer, #13 hollow spring guide #14, 3/16" steel washer, #15 one retainer, #29 speed wrench. Cut #1 mainshaft to 11" overall length, and debur cut end. Using (fig 6) Grease both sides of #7 brass washer with included red grease. Slide #7 down #1 mainshaft. From bottom, slide #1 mainshaft through #9 red bushing. Place base upright. Drop (#14) 3/16" washer down #1 mainshaft. Set #15 retainer, teeth up on top of #1 mainshaft. Use #13 hollow spring guide with flange up to start and push #15 retainer down the shaft and into the post. When the hollow guides flange meets top of post, set end of #29 speed wrench or screwdriver on flange and push guide into post until tight. **Remove #13 hollow spring guide.** Check end play of #1 mainshaft, retighten if necessary.

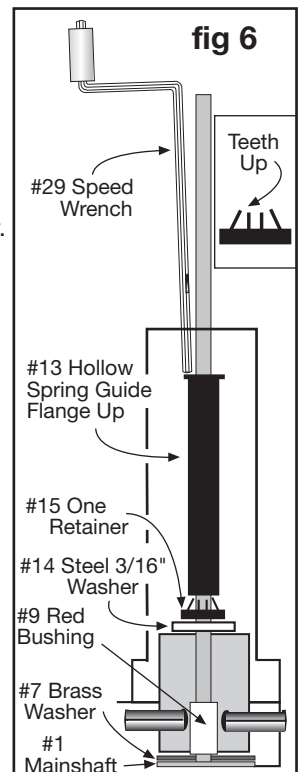
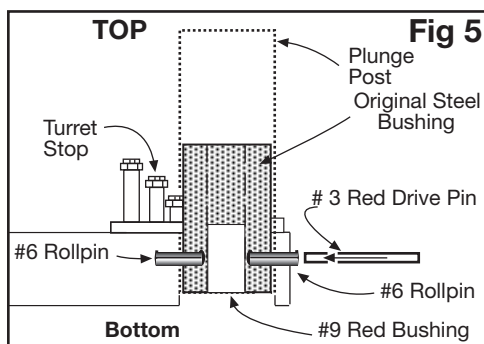

See other side to finish installation

Ryobi RE 600

Reassembling Router (Plunge Springs Must be Installed)

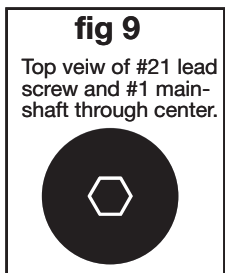

1. Stand base upright, using (fig 7 & 8) replace both plunge springs. Place #13 hollow spring guide in top of #1 mainshaft side spring. Place one original spring guide in top of other spring. **Caution: Do not assemble router without plunge springs and spring guides.**
2. Make sure a brass plug is still in the end of the plunge lock bolt. Look for brass plug inside the motor housing plunge lock bore. The brass plug should be visible in the end of the plunge lock bolt. If missing place grease on tip of brass plug and install.
3. Unlock plunge lock. Grasp router handles and guide springs into motor housing. Slowly lower the motor housing. Aligning #1 mainshaft through #19 short drive nut. Plunge the router and engage plunge lock.
4. Select #12 green bushing (Two #15 retainers) #21 lead screw, #22 rapid collar, #23 O-ring, #24 thumb screw, #26 top drive, #27 yellow set screw, #28 allen wrench, red grease. Using (fig 8) place grease on threads of #21 lead screw, Place lead screw down #1 mainshaft and thread into #19 short nut until one inch of mainshaft extends above the head #21 lead screw. Alignment of #1 mainshaft and #21 screw hex is required (fig 9). **Tip:** # 29 speed wrench can be used to speed threading.

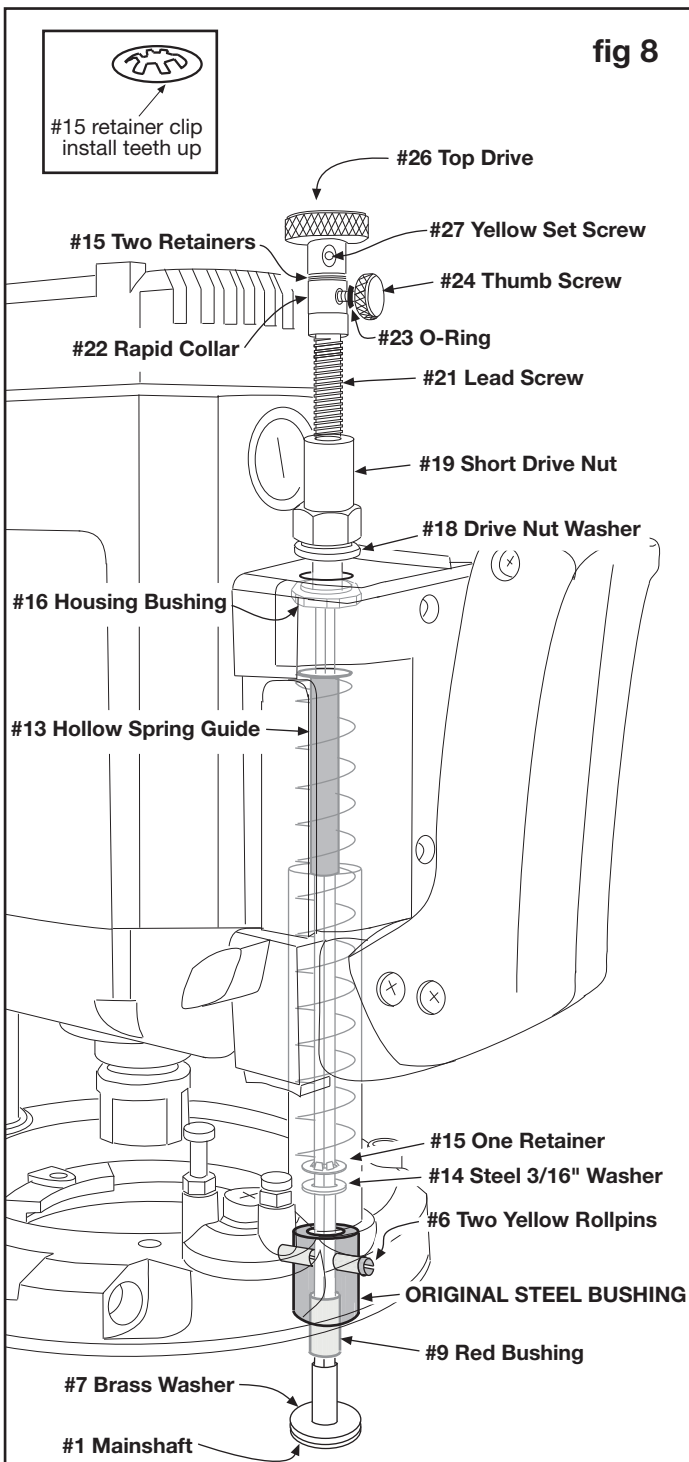

5. Press #23 O-ring onto #24 thumb screw shaft. Thread thumb screw into #22 rapid collar. Place rapid collar onto #1 mainshaft 1/2" from top of mainshaft to top of rapid collar and tighten (fig 8). Release plunge lock and slowly raise the router until lead screw contacts the rapid collar. If the collar moves, reset to 1/2". Place one #15 retainer teeth up on top of #1 mainshaft, using #12 green bushing as installation tool push retainer into contact with collar repeat with second #15 retainer and push flush with first retainer. **Return #12 green bushing to box.** Place #26 top drive onto #1 mainshaft until it contacts retainer clip, Thread #27 yellow set screw into #26 top drive using #28 allen wrench and tighten.

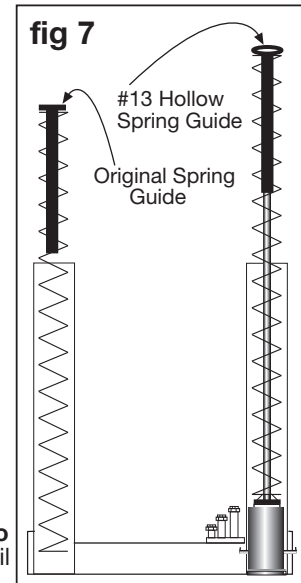

Sub-base or Router Table Insert Plate Installation

1. Use #46 locating pin to locate the Router Raizer access hole on the original subbase or router table. For detailed instructions see page 4. Drill original subbase hole to 3/4" (fig 10). For router table installation see 3/4" pocket or 8" X 8" black rubber spacer page 4,5,6.
2. See pages 4,5,6, for further instruction, #30 dust cover insert and #31 dust cover, are table insert only. Drill a 1/2" hole through insert plate at the Router Raizer access point and press #30 in from top until flush. # 31 sets in #30 and is removed during adjustments with magnet on back edge of # 29 speed handle. These components keep dust from entering the hex drive.
3. **Periodic inspection and re-greasing of #21 lead screw is recommended.**

fig 10 Locate raizer access point on original subbase. Drill a 3/4" hole through subbase

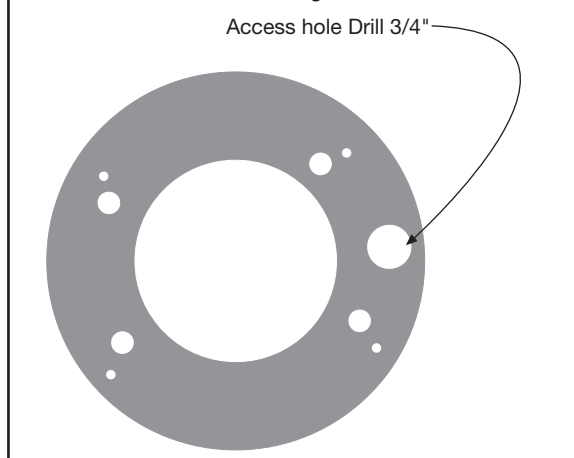

Refer to pages 4,5,6, before using template

NOTE: This router requires a 3/4" pocket or use of 8" X 8" black rubber spacer for router table installation. Pages 4,5,6.

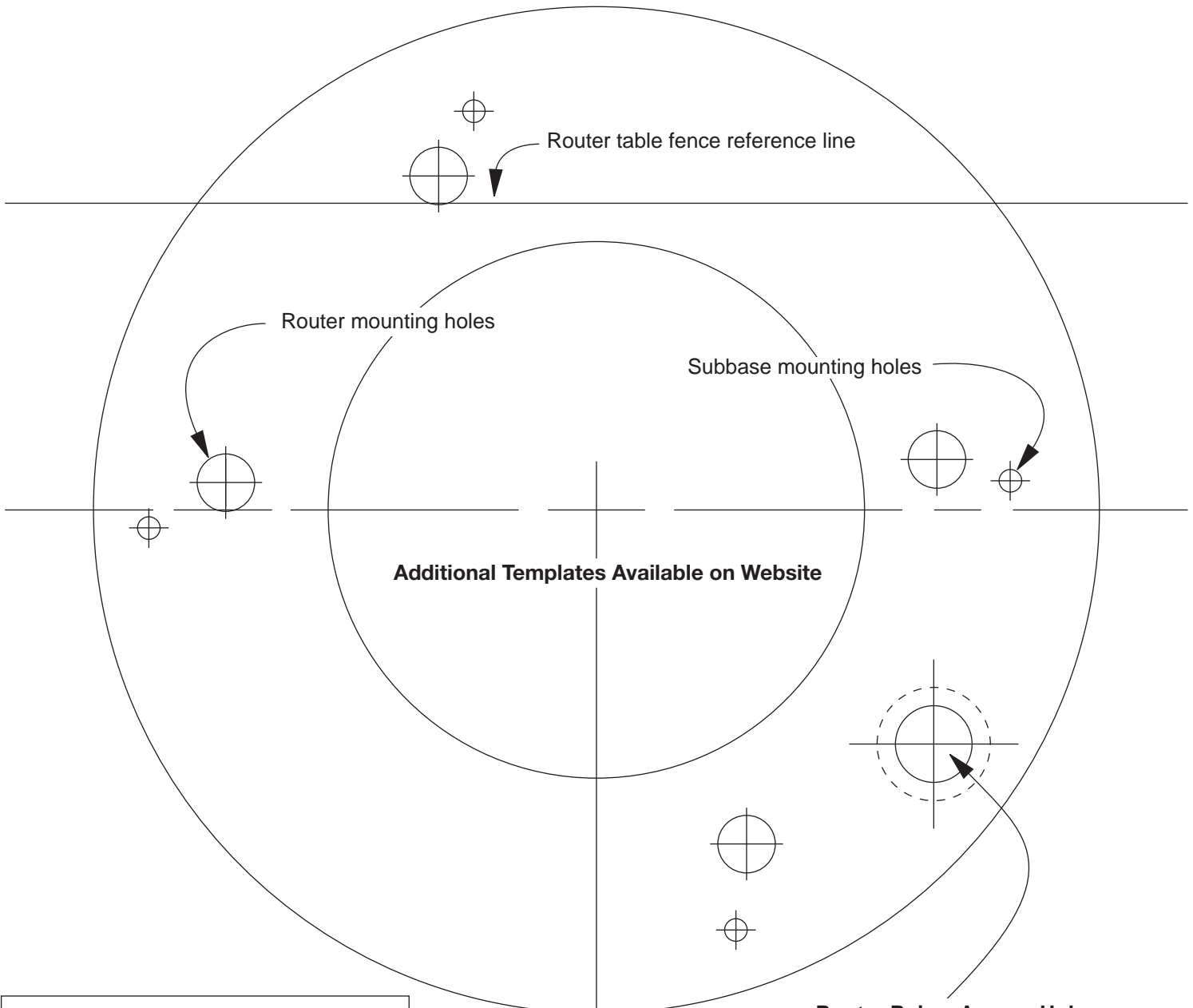

Additional Templates Available on Website

Router Raizer Access Hole

3/4" reference circle for drilling the routers original subbase only. Table mounted, drill 1/2" hole in table top.

1/2" = .500

.500" reference circle for drilling table top or insert plate.

Router Raizer Access Hole

Drill .500" hole through router table insert plate
install #30 dust cover insert into .500" hole and press flush with top of insert plate

NOTE: This hole must be drilled 1/2" or .500" for #30 dust cover insert to fit properly.

Use this 6" scale to check accuracy when copied



Ryobi RE600

Note: Cross lines for locating and drilling holes are accurate. The illustration of subbase may vary slightly in size and design, but is accurate enough for cutting the rubber spacer if required.