

Gigaset

SL910-SL910A

Congratulations

By purchasing a Gigaset, you have chosen a brand that is fully committed to sustainability. This product's packaging is eco-friendly!

To learn more, visit www.gigaset.com.



GIGASET. INSPIRING CONVERSATION.
MADE IN GERMANY

Gigaset SL910/SL910A – with the special "touch"

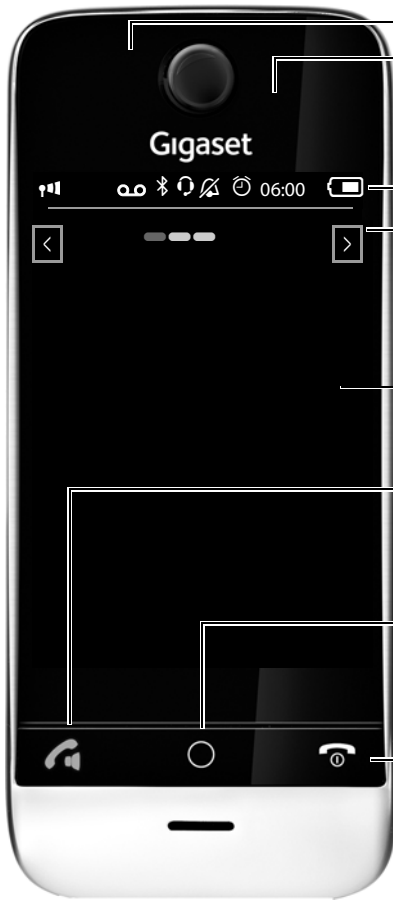

Message LED

Proximity sensor

Touchscreen/display

Status bar (→ enclosed poster)

Icons show the telephone's current settings and operating status. Touch the status bar to open the status page.

Navigation area

Page position marker 
Change page 

Idle displays or menu (→ enclosed poster)

Handset keys

 Talk key

Press **briefly**: Dial displayed number, accept call, switch between earpiece and handsfree mode, open the redial list
Press and **hold**: assign a line

 Menu key

Press **briefly**: open main menus
Press and **hold**: activate/deactivate keypad and display lock

 End call/end key

Press **briefly**: end call/paging, reject internal call, switch off ring tone for external call, return to idle status
Press and **hold**: switch handset on/off

Mini USB connection socket

Connect wire-bound headset or handset to your PC (Gigaset QuickSync)

Charging contacts

Gigaset SL910/SL910A – with the special "touch"

The **base of the Gigaset SL910/SL910A** is supplied in **two variants**. The functionality and features of both variants are **identical**.

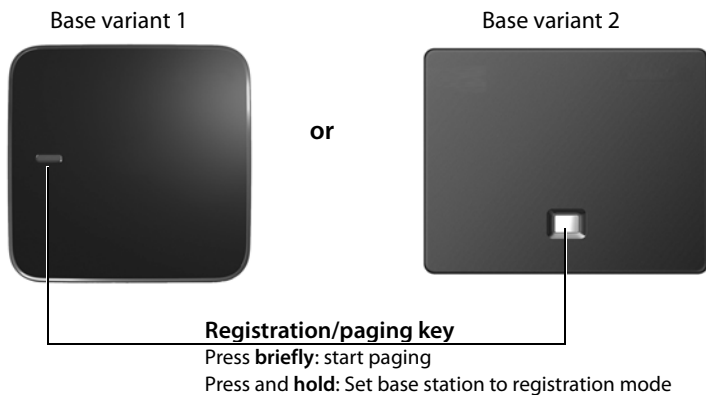

Contents

Gigaset SL910/SL910A – with the special "touch"	1
Safety precautions	4
Getting started	5
Display icons	16
Setting options	17
Answering machine (Gigaset SL910A)	22
Using the telephone	25
Making calls	29
Contacts (address book)	31
SMS (text messages)	33
Room monitor	35
Calendar	35
Alarm	36
ECO DECT – Reducing transmission power (radiation)	36
Bluetooth devices	37
Customer Service & Assistance	38
Manufacturer warranty (Middle East)	40
Service Centres (Middle East)	41
Index	43

Safety precautions

Warning

Read the safety precautions and the user guide before use.
 Explain their content and the potential hazards associated with using the device to your children.



Use only the power adapter indicated on the device.



Use only **rechargeable batteries** that correspond to the **specification** (see "Technical Data"). Never use a conventional (non-rechargeable) battery or other battery types as this could result in significant health risks and personal injury. Rechargeable batteries, which are noticeably damaged, must be replaced.



Using your telephone may affect nearby medical equipment. Be aware of the technical conditions in your particular environment, e.g., doctor's surgery. If you use a medical device (e.g., a pacemaker), please contact the device manufacturer. They will be able to advise you regarding the susceptibility of the device to external sources of high frequency energy (for the specifications of your Gigaset product see "Technical Data").



Do not hold the rear of the handset to your ear when it is ringing or when speaker mode is activated. Otherwise you risk serious and permanent damage to your hearing.

Your Gigaset is compatible with the majority of digital hearing aids on the market. However, perfect function with all hearing aids cannot be guaranteed.

The phone may cause interference in analogue hearing aids (humming or whistling) or cause them to overload. If you require assistance, please contact the hearing aid supplier.



The devices are not splashproof. For this reason do not install them in a damp environment such as bathrooms or shower rooms.



Do not use the devices in environments with a potential explosion hazard (e.g., paint shops).



If you give your Gigaset to a third party, make sure you also give them the user guide.



Remove faulty devices from use or have them repaired by our Service team, as these could interfere with other wireless services.

Please note

- ◆ The device cannot be used in the event of a power failure. It is also **not** possible to transmit **emergency calls**.
- ◆ Emergency numbers cannot be dialled if the keypad lock is activated!

Getting started

Checking the package contents

- ◆ One Gigaset SL910/SL910A **base**
- ◆ One power adapter for the base
- ◆ One phone cable (flattened)
- ◆ One Gigaset SL910H **handset**
- ◆ One battery cover (rear cover for the handset)
- ◆ One battery
- ◆ One **charger**
- ◆ One power adapter for the charger
- ◆ One poster, one user guide and one CD.

Installing the base and charger

The base and charging cradle are designed for use in dry rooms in a temperature range of +5°C to +45°C.

- ▶ Set up the base on a level, non-slip surface at a central point in the building or mount the base on the wall (→ **page 7**).

Please note

Pay attention to the range of the base.

This is up to 300 m in unobstructed outdoor areas and up to 50 m inside buildings. The range is reduced when Eco Mode is activated.

The phone's feet do not usually leave any marks on surfaces. However, due to the multitude of different varnishes and polishes used on today's furnishings, the occurrence of marks on the surfaces cannot be completely ruled out.

Please note:

- ◆ Never expose the telephone to the effects of heat sources, direct sunlight or other electrical devices.
- ◆ Protect your Gigaset from moisture, dust, corrosive liquids and fumes.

Connecting the base with the phone network and the mains power supply

Base variant 1

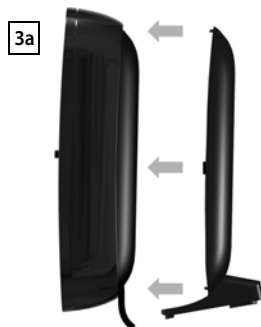
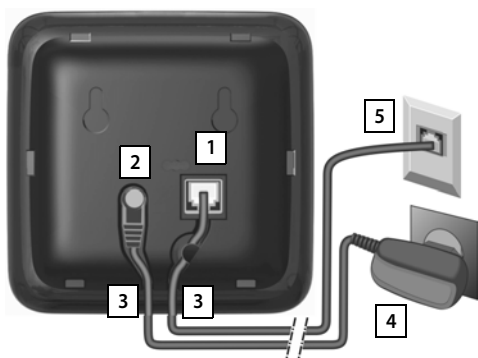

Base variant 2

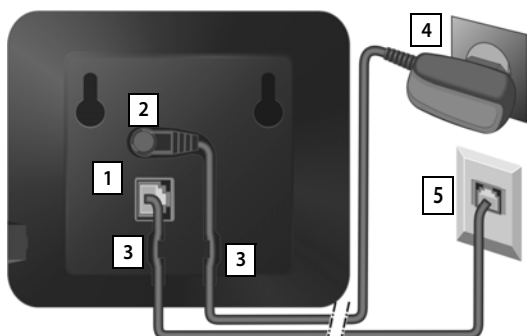

- ▶ Insert the phone cable (cable slightly flattened) into the right/lower connection socket **1** at the rear of the base until it clicks into place.
- ▶ Insert the power cable for the power adapter into the left/upper connection socket **2**.
- ▶ Insert both cables into the appropriate cable channels **3**.
- ▶ Base variant 1: Place the cover in the notches on the back of the base and click into place **3a** (not if mounting on the wall).
- ▶ First connect the power adapter **4** and then connect the telephone jack **5**

Please note:

- ◆ The power adapter must **always be connected**, as the phone will not operate without a power supply.
- ◆ Only use the power adapter and phone cord **supplied**. Pin connections on telephone cables can vary.

Wall mounting the base (optional)

Base variant 1

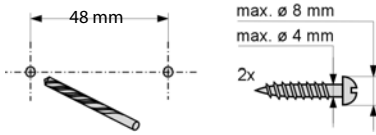

Approx. 2.5 mm

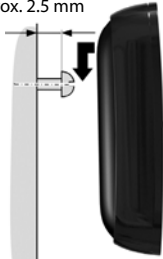

Base variant 2

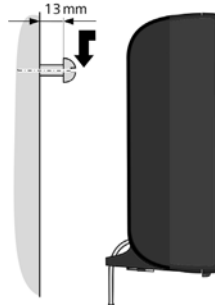
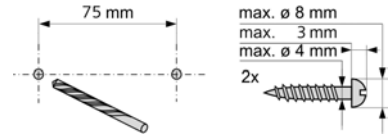

Connecting the charger cradle

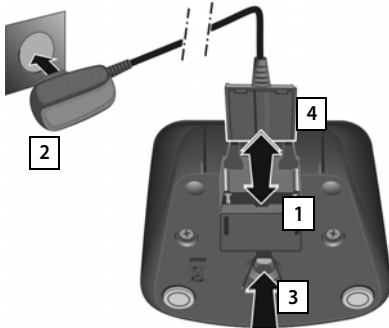

- ▶ Connect the flat plug to the power adapter **1**.
- ▶ Plug the power adapter into the plug socket **2**.

If you have to remove the plug from the charger cradle again:

- ▶ First disconnect the power adapter from the mains power supply.
- ▶ Then press the release button **3** and disconnect the plug **4**.

Setting up the handset for use

The handset's display and keys are covered with a protective film. **Please remove the protective film!**



Caution

Please do **not** use any touchscreen styli to operate the handset!

Do not use protective cover/film from other manufacturers. This can restrict operability of your handset.

Inserting the battery and closing the battery cover

Caution

Use only rechargeable batteries recommended by Gigaset Communications GmbH, as doing otherwise could result in significant health risks and personal injury. For example, the outer casing of the battery could be destroyed or the battery could explode. The phone could also malfunction or be damaged as a result of using batteries that are not of the recommended type.

- ▶ First, insert battery with the contact surface facing down **1**.
- ▶ Then press the battery downwards **2** until it clicks into place.

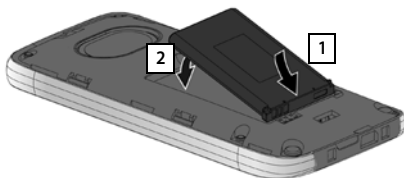

- ▶ First, align the protrusions on the side of the battery cover with the notches on the inside of the casing.
- ▶ Then press the cover until it clicks into place.

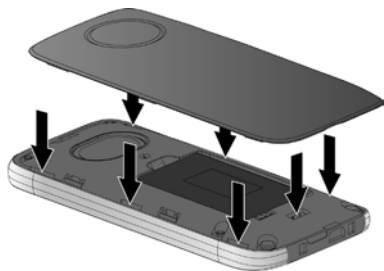

To **reopen the battery cover** to replace the battery:

- ▶ Insert your fingernail into the notch on the bottom of the battery cover and pull the battery cover upwards.



Charging the battery

The battery is supplied with a partial charge. Please charge it completely before use.

- ▶ Charge the handset in the charger cradle for **5 hours**.



Please note

- ◆ The handset must only be placed in the designated charger cradle.
- ◆ The battery is also charged if the handset is connected via a USB connection to a PC with a power supply of 500 mA
- ◆ The battery may heat up during charging. This is not dangerous.
- ◆ After a time, the charge capacity of the battery will decrease for technical reasons.

Registering the handset

Handsets contained in the package have already been registered to the base. If, however, a handset has not been registered (display "**Handset not registered to any base**"), please register it manually. You must initiate registration on the base and on the handset:

- 1) **On the base:** ▶ Press and **hold** (for approx. 3 seconds) the registration/paging key.
- 2) **On the handset** (within 60 seconds): ▶ Press **Register** and if necessary, enter the system PIN of the base (default setting: 0000) and confirm with .

Setting up the base and handset — installation wizard

Once the battery has been inserted, the time and date symbols flash. The installation wizard starts automatically as soon as you touch one of the flashing symbols. It helps you to configure the following key settings on the handset and base. These keys are required for operation:

- ◆ Time and date
- ◆ Display language
- ◆ Country in which the phone will be used
- ◆ Your own area (dial code)

Getting started

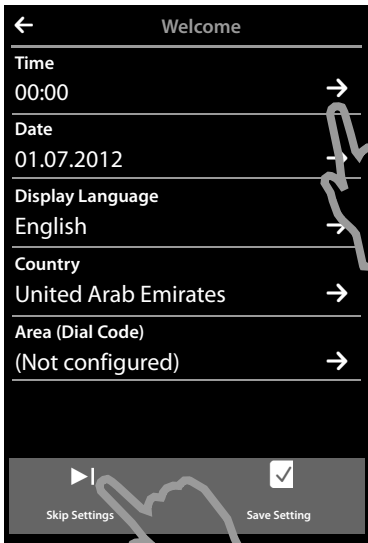

If you do not want to configure the settings at this point:

- ▶ Touch the [▶] **Skip Settings** option at the bottom of the display.

The handset then switches to idle status.

You can configure the settings at a later stage using the **Settings** menu on your handset.

If you want to configure the settings:

- ▶ Touch the ▶ icon next to the time to set the time.

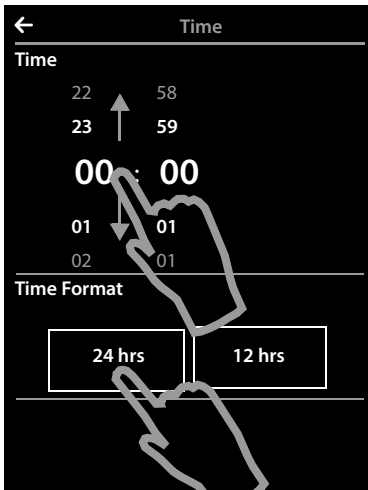

- ▶ Use the left-hand number wheel to select the current hour by touching the number wheel with a finger and moving it upwards or downwards. The number wheel will follow your movements.
- ▶ Operate the right-hand number wheel in the same way to select the minutes.
- ▶ Specify whether you wish the time to be displayed in **12 hrs** or **24 hrs** mode. To do this, touch the corresponding area under **Time Format**. The current setting is highlighted.
- ▶ Touch the ◀ icon (at the top left of the display) to save the settings and return to the **Welcome** page.

Comment: If you set the **12 hrs** mode, **am/pm** is shown next to the number wheels.



- ▶ Touch the ▶ icon next to **Date** to set the date.





- ▶ Use the three number wheels to set the current date. The procedure is the same as for setting the time.

The current mode for displaying the date is displayed under **Date Order** (here: **Day Month Year**). If you want to change the mode:

- ▶ Touch the  icon.



The date order setting is indicated by .

- ▶ Touch the  icon to switch between **Day Month Year**/**Month Day Year**
- ▶ Keep touching the  icon until the **Welcome** page appears.



The current language is displayed under **Display Language**.

If you want to change the setting:

- ▶ Touch the  icon next to the displayed language.

Getting started

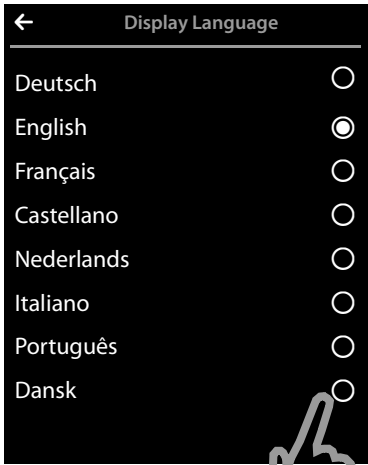

This brings up a list containing all the available languages.

The current language is marked with .

► Touch the  icon next to the required language.

If your language is not displayed, the list may be "longer" than the display. You must then scroll through the list.

► To do this, put a finger on the display and move it slowly upwards.

The lower section of the list is then displayed and you can select a language.

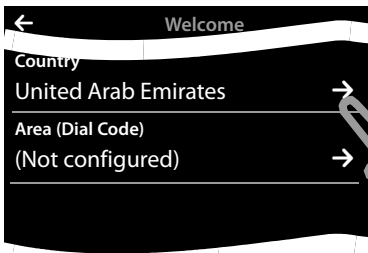

Under **Country** enter the country in which you will operate the phone and for which it is authorised. If the setting is not correct:

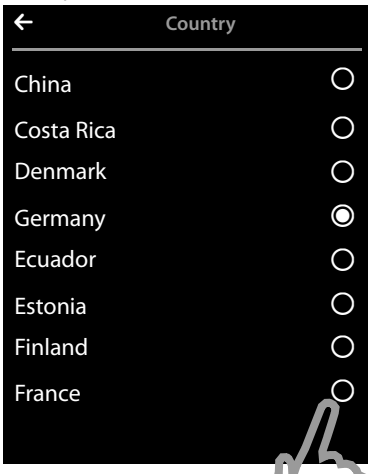

► Touch the  icon next to **Country**.

(Example)



A list of countries is displayed.

The current country is marked with .

► If necessary, as mentioned before, you must scroll through the list to find your country. Touch the  icon next to your country. The  mark moves to this country.

► Touch the  icon to save the change and to return to the **Welcome** page.

Please note

If you have selected **Other Country** instead of a country, the **Welcome** page will also show the **Country (Dial Code)** entry.

- ▶ Touch  next to **Country (Dial Code)** and enter the **International Prefix** and **International Area Code** for the international country code, as described below for the area (dial code).

Proceed as described below.

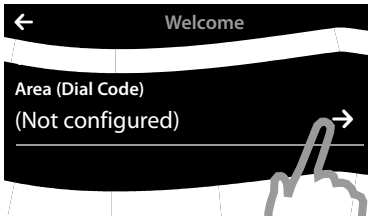



Finally, you have to enter your area (dial code):

- ▶ Touch the  icon next to **Area (Dial Code)**.



The **Local Prefix** is the country-specific local prefix that precedes the **Local Area Code**, when the country code itself is not given.

- ▶ On the keypad displayed, enter the **Local Prefix** of your country in the first field (maximum 4 characters; in the example, "0"). This may already be populated for the selected country.
- ▶ Briefly touch the second input field and enter the **Local Area Code** (maximum 8 characters, in the example "89"). You can correct incorrect entries using .
- ▶ Touch  after entering the numbers to complete the entry.

Getting started

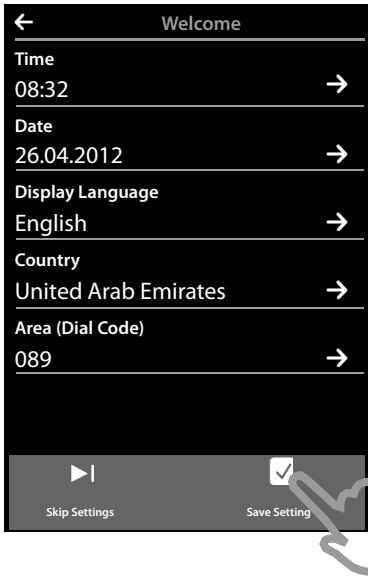

The **Welcome** page is displayed again.

- ▶ Touch the [**Save Setting**] option to save your settings.

Once you have configured all the necessary settings, your handset switches to idle status.

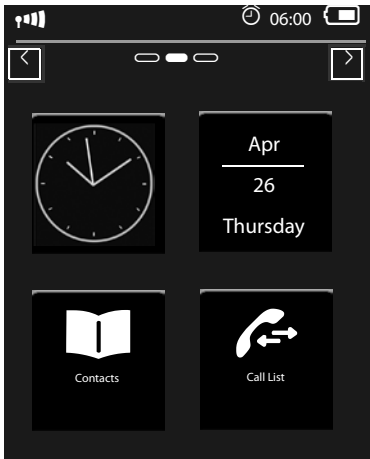

Your phone is now ready for use.

What would you like to do next?

After successfully setting up the phone, you can make calls straight away, customise your Gigaset according to your requirements or firstly familiarise yourself with the touch display (→ **Using the telephone, page 25**).

Creating your own idle display page

Use your configurable idle display page to collate important functions and phone numbers that you want to start or dial via the one touch display (→ attached poster).

Synchronising with contacts in Google or Outlook

Synchronise your handset's Contacts list using your PC and our Gigaset QuickSync software. For the free download and more information, see www.gigaset.com/gigasets910.

Setting ringtones and silent alert

Assign specific tunes to internal and external calls, reminders, wake-up calls and to certain callers. Use time management for calls.

Menu option **O**. ▶ Return to the **Settings** menu page ▶  **Audio Settings**]

Setting up the answering machine

Record your own message and set your recording parameters.

Menu option **O**. ▶ Return to the **Settings** menu page ▶  **Answer Machine**]

Registering existing Gigaset handsets to the base

Use these handsets to continue calling from your new base. Transfer Contacts entries from these handsets to your new handset. For further information see the user guides for these handsets.

Making ECO DECT settings

Reduce the transmission power (emissions) of your phone.

Open the status page. ▶ Switch **Eco Mode** (reduce range)/**Eco Mode+** (switch off wireless) on/off with the applicable switch.

Download your personal ringtones and images to your handset.

Connect your handset to your PC via Bluetooth/USB and download ringtones and images to your handset with the help of our **Gigaset QuickSync** software. For the free download and more information, see www.gigaset.com/gigasets910.

- ◆ For more details about your telephone functions, please refer to the user guide on the CD supplied or online at www.gigaset.com.
- ◆ If you have any questions about using your phone, please read the troubleshooting tips attached to this user guide or contact our Customer Care team (→ **page 38**).

Display icons

Options bar icons

The following functions are available in the options bar depending on the operating situation.

Icon	Action
	Activate speaker mode
	(Speaker mode is activated) Deactivate speaker mode
	Speaker profile
	Mute handset microphone
	Unmute handset microphone
	Deactivating the ring tone
	Setting the volume
	Open call lists
	Opening Contacts
	Accept number in Contacts
	Create SMS
	Sending an SMS
	Reply to SMS
	Opening the draft list
	Deregistering the handset
	Open list of internal callers/make internal call
	Create new Contacts entry
	Initiating a consultation call:
	Initiate/end three-way conference call
	Speed dial
	Copy list
	Copy entry
	Editing entries
	Show keypad
	Determine free memory in the media pool
	Search
	Skip settings

Icon	Action
	Deleting
	Save/select
	Enter new appointment
	Calendar: Set selected date to Today
	Change order (sort by last name or first name)
	Contacts entry: Delete caller ring tone assignment
	Contacts entry: Delete caller picture assignment
	Delete birthday
	Trust Bluetooth device found
	Divert call to answering machine
	Play messages
	(red) Recording an announcement
	Stop recording
	During message playback: Go back five seconds

Please note

The menu icons can be found in the menu overview on [page 17](#).

Setting options

Open the **Settings** menu page:

- ▶ **Briefly** press menu key **O** when the handset is in idle mode.
- ▶ Drag your finger horizontally across the display to switch to the **Settings** menu page.

Please note

Not all of the functions described in this user guide are available in all countries.

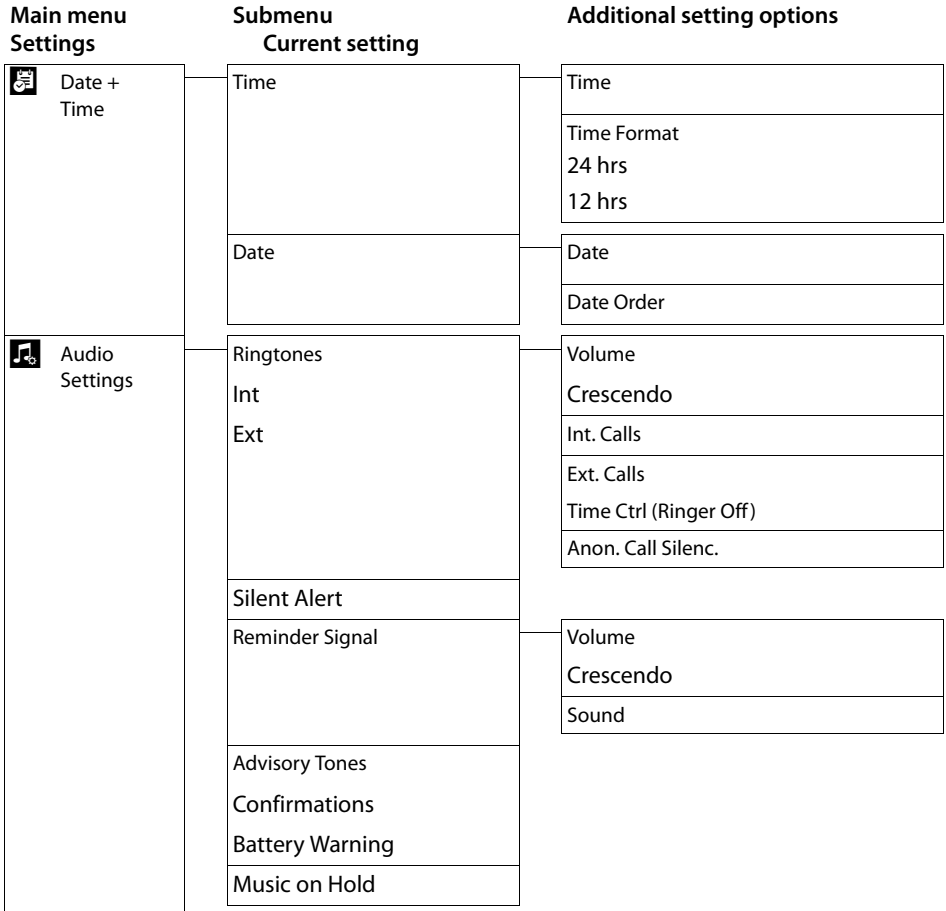

Setting options

Main menu Settings

 Display + Keypad

 Language + Location

Submenu Current setting

Screensaver
Activation
Selection

Backlight
In Charger
Out of Charger
Timeout

Number Info in Dial Lists

Indication of New Messages
LED + Display Info

Keypad
Key Tones
Key Vibration
Keypad with R/P
Keypad w. Letters

Display Language
Country
Country (Dial Code)
Area (Dial Code)

Additional setting options

- Slideshow
- Analogue Clock
- Digital Clock 1
- Digital Clock 2
- (List of **Screensavers** images)

15 sec. / 30 sec. / 1 min. / 2 min.

- Number Type Only
- Type and Number

— List of available languages

— List of countries

Only if **Country = Other Country**

**Main menu
Settings**

 Handsets + Base

 System

**Submenu
Current setting**

This Handset
Register
De-register
Rename

Registered Handsets
(List of registered handsets)

Connected to Base

ECO DECT
Max. Range
No Radiation

Repeater Mode

Security Check
System PIN

Resets
Handset Reset
Base Reset
Clean-up List

Additional setting options

(Only if more than one handset is registered)

Base 1

:

Base 4

Best Base

Appointments
All Past Appointments

Calls
Missed Calls
Accepted Calls
Outgoing Calls

Messages
Text Messages
Answer Machine





Contacts

Setting options

Main menu Settings

Submenu Current setting

Additional setting options

 System	Only with base variant 2 (even after firmware update)	
	Local Network 192.168.2.2 (Current IP address)	IP Address Type Static Dynamic
		IP Address Subnet Mask Default Gateway Preferred DNS server
	Firmware Update	Automatic Check Update Firmware
 Telephony	Auto Answer	
	Listening In	
	Access Code Use	Never Calls from Call Lists All Calls
	Dialling Mode	Tone Pulse
	Recall	80 ms/.../800 ms
 SMS Service Centres	Active Send Centre	
	Service Centr. 1 : Service Centr. 4	
 Bluetooth	Own Device	
	Known Devices	
	Activation	
	Devices found (only if Activation = on)	Device Name

**Main menu
Settings**

**Submenu
Current setting**

Additional setting options

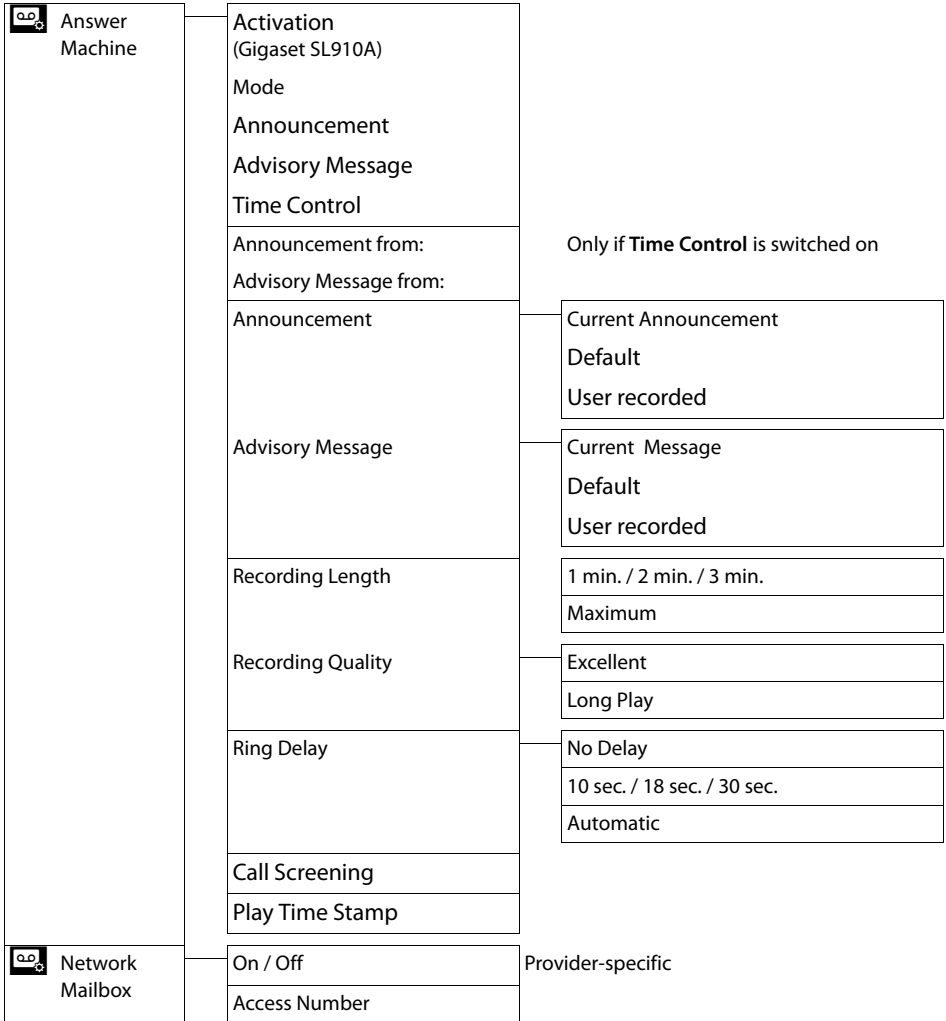

Please note

This quick user guide only describes a small proportion of your telephone's functions. You will find an extensive description of all functions contained in the menu overview in the detailed user guide for your Gigaset SL910/SL910A both on the enclosed CD and on the Internet at www.gigaset.com.

Answering machine (Gigaset SL910A)

Open the submenu for setting and operating the answering machine:

- ▶ Menu key **O** ▶ Menu page **Settings** ▶ [**☰**] **Answer Machine**

Activating/deactivating the answering machine

- ▶ Activate/deactivate the answering machine with the switch next to **Activation**.

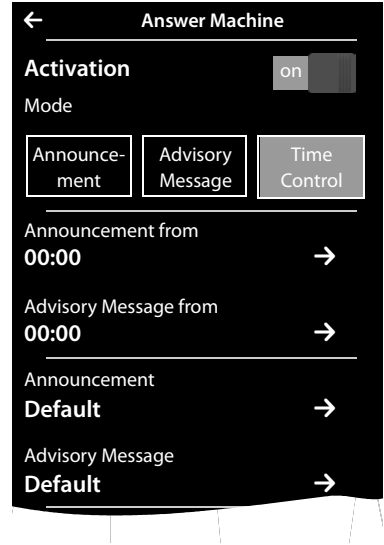

Setting up the answering machine

Define Mode

- ▶ Touch the corresponding area (activated mode is highlighted).
 - **Announcement:** The caller can leave messages.
 - **Advisory Message:** The caller only hears a recorded message.
 - **Time Control:**
 - ▶ Next to **Announcement from/ Advisory Message from** touch **[⌚]** ▶ Enter the times when the relevant mode should be activated
 - ▶ Save and return with **[←]**

Recording a personal announcement/advisory message

Recording a new announcement deletes the announcement previously saved.

- ▶ Scroll to **Announcement** or **Advisory Message** and touch the relevant **[▶]**
- ▶ Touch [**● Record own**] / [**● Re-Record**] ▶ Record an announcement after the ready tone (minimum 3 seconds up to a maximum of 180 seconds).
- ▶ Touch [**■ End**] to complete and save the recording.

Cancel a recording: Briefly press the end call key **[⏏]** or touch **[←]** while recording.

After recording you can:



- ▶ **Listen to the announcement:** Touch [**▶ Play**].
- ▶ **Repeat your recording:** During playback, touch [**● New**].
- ▶ **Delete the recording:** Touch [**■ Delete**] and confirm with **Yes**.

Please note

- ◆ Recording ends if there is a pause lasting longer than 3 seconds.
- ◆ If you cancel the recording, the default announcement is used.
- ◆ If the answering machine's memory is full, it switches to **Advisory Message** mode. After old messages have been deleted, it switches back into **Announcement** mode.

Additional setting options

◆ Setting the recording parameters:

- ▶ Scroll until you reach the desired recording parameter:
- **Recording Length:** 1 min., 2 min., 3 min. or **Maximum**.
- **Recording Quality:** Excellent or Long Play.
- **Ring Delay:** No Delay, 10 sec., 18 sec., 30 sec. or **Automatic** (10 seconds if there are new messages, otherwise 18 seconds).
- ▶ Next to the relevant recording parameter, touch 
 - ▶ Touch the desired setting ( = selected)
 - ▶ Save and return with 

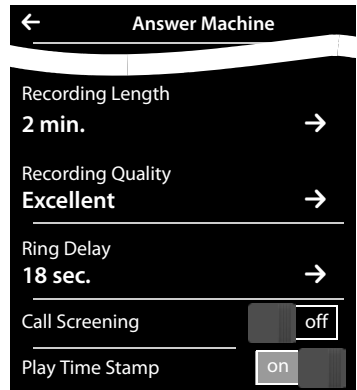



◆ Switching call screening on/off on the handset:

- ▶ Touch the switch next to **Call Screening**.





Deactivating call screening for the current recording: ▶ Touch [ **Silence**] or press .

◆ Activating/deactivating playback of the recording time: ▶ Activate/deactivate playback with the switch next to **Play Time Stamp**.

Playing/deleting messages

- ▶ Switch to the message page ▶ Touch the  icon.
 - ▶ **Listen to all new messages:** Touch [ **Play all new**].
 - ▶ **Listen to individual messages:** Touch list entry.
 - ▶ **Call the caller of the entry marked with the green dot:** Press .

The following options are available during message playback:

- ◆ Adjust the playback volume: [ **Volume**],
- ◆ Repeat the last 5 seconds of playback: [ **5 sec.**],
- ◆ Copy the caller's number to contacts: [ **Copy Number**],
- ◆ Delete message: [ **Delete**].

Deleting all messages

- ▶ Menu key  ▶ Menu page **Settings** ▶ [ **System**] ▶ (Scroll if necessary) ▶ Next to **Clean-up List** touch  ▶ Touch  next to **Answer Machine** ▶ Confirm with **Yes**.

More answering machine functions



◆ **Pick up call during answering machine recording**

▶ Press  or touch [ **Accept**].

◆ **Divert call to answering machine:**

If the answering machine is switched on and the handset is displaying an external call

▶ Touch [ **Divert**]. The answering machine starts immediately in **Announcement** mode.

◆ **Two-way recording of external call:** ▶ In the options bar, touch  ▶ Touch [ **Record**] to start and end the two-way recording.

Tell the other party that the call is being recorded.

During a two-way recording, all options apart from [ **End Recording**] are greyed out. You cannot initiate a consultation call, nor accept nor reject a waiting call.

Please note

You will find further information about using the answering machine while you are away from home (remote operation) in the detailed user guide for your Gigaset SL910-SL910A on the enclosed CD and on the Internet at www.gigaset.com.

Using the telephone

Activating/deactivating the handset

In idle status, **press and hold** the end call key .

Returning to idle status

- ▶ **Briefly** press end call key .

Or:

- ▶ If you do not press any key and do not touch the display, the display **automatically** reverts to idle status after approximately three minutes.

Activating/deactivating key and display lock

The key and display lock prevents the phone being operated unintentionally.

- ▶ Press and **hold** the  menu key to activate or deactivate the lock.

When you activate the key and display lock, the message **Keys and display locked** is displayed briefly. The display backlight switches itself off.

You can accept the incoming call, despite the lock.

The key and display locks activate again once the call has finished.

Please note

- ◆ When the keypad lock is active, you cannot call emergency numbers.
- ◆ The display is automatically locked with the aid of a proximity sensor if you hold the handset to your ear (display backlight disappears). This lock is deactivated again when you remove the handset from your ear.
The sensor is located on the right next to the earpiece. If you cover it accidentally with your finger during a call, the display will also be locked.

Operating the touchscreen

You operate the handset mainly via the display.

Icons, list entries, switches and selection areas shown on the display are sensitive areas. You can set up and activate functions, enter or dial phone numbers and navigate between the various display screens (pages) by touching these areas and dragging them across the display.

Selecting functions/list entries

Touch a list entry or the corresponding icon to select the list item (Contacts, submenu, call lists) or to activate/deactivate a function.

Scrolling in lists and menus (scrolling vertically)

- ▶ Drag the display in a vertical direction.

If there are more list entries than can be displayed all at once, a drop shadow at the bottom or top edge of the display indicates the direction in which you have to scroll to view more of the list.

As soon as you scroll in a list, a scroll bar appears on the right side of the display. This shows the size and position of the visible section of the list.



Scrolling through lists is not continuous, i.e., you have to scroll back to return to the top from the end of the list.

Options, option slider



Many displays have an **options bar** at the bottom. This displays all the actions that you can apply in the current context (icons used, → [page 16](#)). There are single-row (e.g., in Contacts) and double-row option sliders (e.g., during an external call).

- ▶ Touch an option to execute the corresponding action.

If there are more options available than can be displayed in an options bar at the same time, these additional options are provided as follows:

- ◆ With a one-line options bar, the arrow on the right  and/or left  next to the options (see image) indicates that further options are available.
 - ▶ Touch the option slider and drag it in the direction of the arrow in order to move the additional options into the display (scroll horizontally).



- ◆ With a two-row option slider, the icon  below the option slider indicates that further options are available.
 - ▶ Touch  to display a further option slider that conceals the original option slider.

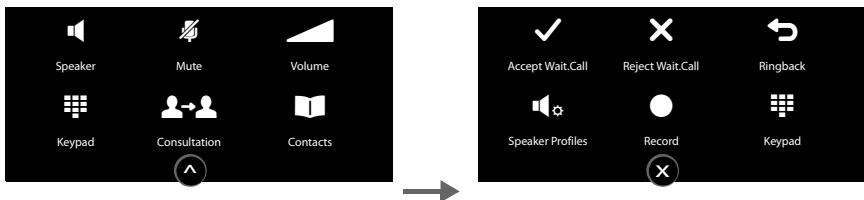

- ▶ Touch  to hide the additional options again.

Changing the settings

Touch an icon on one of the menu pages to open the corresponding application/function. The display shows the configurable parameters and user interface elements as well as their current settings (orange in the display).

Examples:

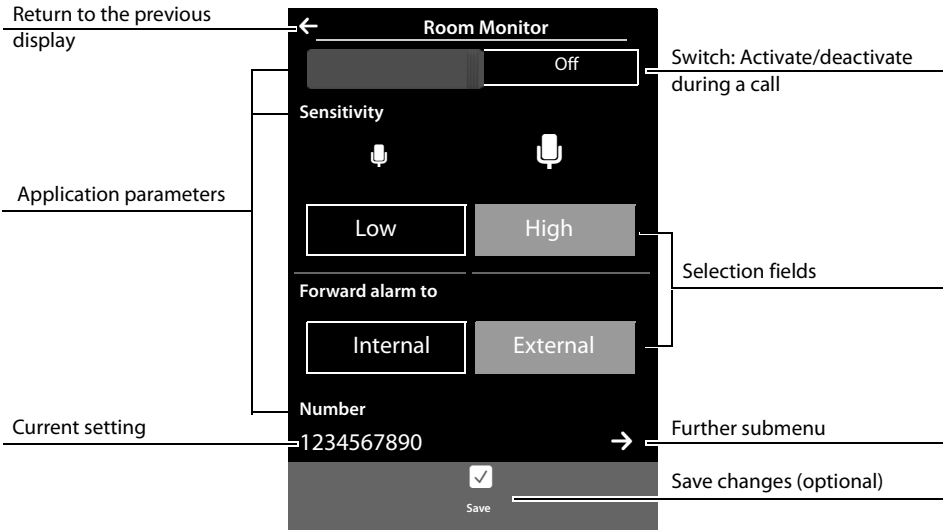

Switch: Activating/deactivating functions

- **Briefly** touch the switch to activate/deactivate functions such as baby-phone call or answering machine.



The function is activated/deactivated if the orange-coloured area (**On / on**) is visible.

Selection fields

If two or three alternative settings are available for one parameter, these alternatives are displayed in the form of selection fields. The current setting appears in orange.

- To change it, briefly touch the selection field you require.

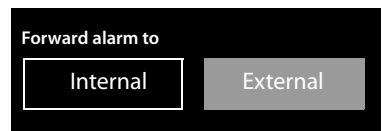

Opening the submenu to set a parameter

The  icon indicates that another submenu is available.

- Briefly touch  to open this submenu.

Entering numbers and text



Touch a character on the display to enlarge it. Keep your finger on the display until you see the desired character enlarged. As soon as you remove your finger from the display, the character is copied to the text field in which the cursor is blinking.

Correcting incorrect entries







































Briefly touch : The last character you entered is deleted.

Press and hold : The entire content of the number or text field is deleted.















Entering text

- ▶ Shift key : Toggle between lower and upper case.
- ▶ Number key : Enter a numeral/special character.
 - ▶ **More...**: Enter further special characters.
 - ▶ **abc**: Return to text entry.
- ▶ Enter special letters (diacritical characters, e.g., umlauts): Press and **hold** the corresponding initial letters, select characters from the list.









Latin (default) character set:

a         c   e      i    
l  n   o       s   u    
y   z  



Greek character set:

α  ε  η  ι     ο  σ  υ     ω 

Cyrillic character set:

е    и    г  б 

Due to the larger space requirement of the Cyrillic character set, you can also access the following letters by pressing and **holding** the bold characters shown below. Touch the required character.

ц  х  ж 

- ▶  (touch repeatedly if necessary): Change character set/keyboard layout. The options are:
 - Latin (default) character set with QWERTZ keyboard layout (central Europe), QWERTY (American default) and AZERTY (French-speaking area)
 - Greek character set
 - Cyrillic character set

Making calls

Making an external call

- ▶ Call up the dial page, enter the number and briefly press .

Or:

- ▶ Press and hold ; enter number.

You can cancel dialling by pressing .

Dialling with the redial list

- ▶ Briefly press  to open the redial list. ▶ Briefly touch a list entry.

Dialling from a call list

- ▶ Call-up messages page. ▶ Open the desired list. ▶ Briefly touch a list entry.

Dialling with Contacts

- ▶ Open Contacts: On the dial page, touch [ Contacts].

You have the following options:

- ▶ Press . The default number of the entry marked with the green dot is dialled.

Or:

- ▶ Touch the name in the entry. The default number of the entry is dialled.

Or:

- ▶ Touch  next to the entry and then touch the required number in the detail view.

Making internal calls

Internal calls to other handsets registered to the same base are free of charge.

- ▶ Open the dial page. ▶ Touch [ Internal]. ▶ If necessary, select the handset from the list or touch **All Handsets** (group call).

Accepting a call

- ▶ Press .

Or:

- ▶ If **Auto Answer** is activated, remove the handset from the charger.

Or:

- ▶ Gigaset SL910A: Touch [ Divert] to divert the call to the answering machine.

Speaker



If you are going to let someone listen in, you should tell the other party that this is happening.

Activating while dialling

- ▶ Enter the number, press  twice.

Switching between earpiece and speaker mode

During a call, when establishing the connection and when listening to the answering machine (Gigaset SL910A only):



- ▶ Press  or touch [ Speaker].

Placing the handset in the charger during a call:

- ▶ Press and hold  while placing the handset in the charger and hold for a further 2 seconds.

Changing the earpiece, handsfree and headset volume

You adjust the volume for the current mode (handsfree, earpiece, headset) during a call:

- ▶ Touch [ Volume] ▶ Adjust the volume with \oplus / \ominus .
- ▶ If a headset is connected: To adjust the **Microphone Sensitivity** touch \oplus / \ominus in the second row several times if necessary.
- ▶ Touch  at the bottom of the display to save the settings.
Or: The setting is saved automatically after approximately 2 seconds.



Activating/deactivating the microphone (muting)

If you turn the microphone off during a call, your caller can no longer hear you.

- ▶ To activate/deactivate the microphone, touch [ Mute].

Using provider-specific functions (network services)

You have to request these services from your network provider (there may be additional charges). Network services fall into two distinct groups

- ◆ Network services that are activated outside of a call for the next call or all subsequent calls (e.g., "Divert calls to a different phone connection", "Withhold number (no calling line identification)"). You can easily activate/deactivate these network services via the sub-menu [ Select Services] on the **Settings** menu page.
- ◆ Network services that are activated during an external call, e.g., "consultation", "swap between two callers", "set up conference calls". These services are provided to you during an external call in the option slider (e.g., [ Consultation], [ Conference]).

For additional information on the network services, see the user guide on the enclosed CD and on the Internet at www.gigaset.com.

Contacts (address book)

Managing entries in Contacts

Opening Contacts

- ▶ Menu key ▶ [Contacts] or
- ▶ Touch [Contacts] on the dial page or during a call.

Creating a new entry

- ▶ Open Contacts. ▶ Touch [New Entry]. ▶ Enter the components of the entry (touch next to the component concerned). ▶ Confirm a component with or [Select] as necessary.
- ▶ Add caller picture: ▶ Touch []. ▶ Select picture with / and touch [Select].
- ▶ Touch [Save].

highlights the standard number of the entry that is automatically selected when you touch the entry in Contacts.

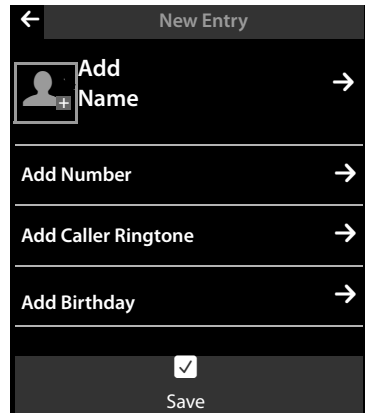

Viewing entries

- ▶ Open Contacts. ▶ Touch next to an entry to open the detail view.

Editing entries

- ▶ Touch [Edit] in the detail view.
 - Edit/delete name, surname or number: ▶ Touch ▶ If necessary, touch the corresponding field. ▶ Enter/edit name/number. ▶ Confirm with .
 - Assign a VIP ringtone or delete a birthday: ▶ Touch next to **Add Caller Ringtone/ Add Birthday**. ▶ Touch [No Ringtone]/[No Birthday].
 - Delete assignment of a caller picture: ▶ Touch the caller picture. ▶ Touch [No Picture].
 - Edit standard number: ▶ To activate a number other than a standard number, touch next to this number.
- ▶ Touch [Save].

Deleting an entry

- ▶ Touch [Delete] in the detail view. ▶ Press **Yes** to confirm.

Delete **all** entries in Contacts:

- ▶ Menu key ▶ Menu page **Settings** ▶ [System] ▶ (Scroll if necessary) ▶ Next to **Clean-up List** touch ▶ Next to **Contacts** touch ▶ Confirm with **Yes**.

Transferring an entry/Contacts to another handset

- ◆ The sending and receiving handsets must both be registered to the same base.
- ◆ The other handset and the base can send and receive Contacts entries.



Transferring individual entries

- ▶ Open the detail view for the entry. ▶ Touch [ Copy].
 - ▶ Answer the prompt with **Internal Handset**. Select the recipient handset.

Transferring the entire Contacts list

- ▶ Open Contacts. ▶ Touch [ Copy List].
 - ▶ Answer the prompt with **Internal Handset**. ▶ Select the recipient handset.

Adding a displayed number to Contacts

- ▶ Touch [ Copy Number]. You have the following options:
 - Create new entry (→ **page 31**): ▶ Touch [ New Entry]. The number is copied as the first number of the entry with number type **Home**.
 - Add a number to an existing entry:
 - ▶ Open the detail view for the entry. ▶ Touch **Add** . Number is entered with number type **Home**.
 - Or:
 - ▶ Select the number you want to overwrite. ▶ Touch **Yes**.

Configuring QuickDial/QuickDial shortcuts

You have two options:

- ◆ Create, for each number, a symbol on the configurable (own) page.
- ◆ Transfer a number to the QuickDial shortcuts.

Creating a QuickDial icon on the configurable page

- ▶ Open the configurable page and start the configuration (press and hold the display).
 - ▶ Drag icon  from the selection bar onto the page. ▶ Select the Contacts entry.
 - ▶ Where an entry has several numbers, the detail view will open: select telephone number.



An icon for QuickDial is created on the configurable page. The number is not entered into the QuickDial shortcuts.

Dial number: ▶ Touch the QuickDial shortcut icon on the configurable page.



Delete QuickDial: ▶ In configuration mode, drag the QuickDial icon to be deleted into the selection bar. The Contacts entry does not change.

Transferring the telephone number to the QuickDial shortcuts

The QuickDial shortcuts can contain a maximum of 7 entries.

- ▶ Switch to the dial page and touch [ QuickDial]. ▶ Touch [ New Entry]. ▶ Select the Contacts entry. ▶ Where an entry has several numbers: open the detail view and select telephone number.

Dial number: ▶ Open the dial page and touch [ QuickDial]. ▶ Select an entry. ▶ Press .

Delete entries: ▶ Touch [ Delete]. ▶ Touch all the entries to be deleted in sequence and then [ Delete].

Please note

If you change/delete a number from Contacts, the same number is automatically deleted from the QuickDial list.

SMS (text messages)





The following prerequisites must be satisfied if you wish to use the SMS function.

Prerequisites:

- ◆ Calling Line Identification is enabled.
- ◆ Your network provider supports SMS within the fixed line network.
- ◆ You have entered the telephone number of at least one SMS centre (→ [page 34](#)).
- ◆ To receive SMS messages, you must be registered with your network provider.
This usually occurs automatically when you send your first text message.

Writing and sending text messages

Your system can send a **linked SMS** (made up of up to four individual SMS messages) as one message.

Write SMS: ▶ Menu key  ▶ [ Write Text Message]. ▶ Touch the **To** field. ▶ Enter the recipient's number **with area code**. ▶ Confirm with . ▶ Touch the **Message** field. ▶ Enter the SMS text. ▶ Confirm with .







Send SMS: ▶ Touch [ Send].

Please note

- ◆ If the SMS text cannot be displayed in full, you can scroll up and down within the text.
- ◆ Position the cursor within the text: touching the left half of a word will position the cursor and the new text in front of this word. Touching the right half of the word will position the cursor and hence the new text after this word.
- ◆ **Sending SMS messages can result in additional costs.** Please consult your provider.

Receiving, reading and managing SMS messages

Received text messages are saved in the incoming message list. If text messages are saved in this list the symbol  is displayed on the messages page in the standby display.



- ▶ Open the messages page. ▶ Touch the  symbol. ▶ Touch  next to the text message entry. You have the following options:
 - [ **Reply**]: Write and send an SMS to the sender.
 - [ **Edit**]: Edit the SMS text and return it to the sender.
 - [ **Delete**]: Delete the SMS.
 - Press : Call sender of the SMS.
 - **Touch sender/number in the message text**: Call number or save in Contacts. The number must not contain spaces or special characters.

Delete the entire contents of SMS inbox and drafts list:

- ▶ Menu key  ▶ Menu page **Settings** ▶ [ **System**] ▶ (Scroll if necessary) ▶ Next to **Clean-up List** touch  ▶  **Touch Text Messages** next to ▶ Confirm with **Yes**.

SMS centre





If you wish to use the SMS function, you must have saved the telephone number of at least one SMS centre in the device.

- ▶ Check **Active Send Centre**: ▶ Menu key  ▶ Menu page **Settings** ▶ [ **SMS Service Centres**]

Ask your service provider for the telephone number of an SMS centre.

SMS messages are received from **every** entered SMS centre as long as they are registered with their service provider. Your SMS messages are sent via the SMS service centre that is entered as the active send centre.

Entering/changing the SMS centre, setting the send centre

- ▶ Menu key  ▶ Menu page **Settings** ▶ [ **SMS Service Centres**] ▶ Next to an SMS centre, touch  ▶ Enter the telephone number of the SMS centre ▶ Confirm with .
- ▶ If necessary, repeat the procedure for the other SMS centres.
- ▶ **Specify Active Send Centre**: Touch the number of the SMS centre (1–4) you wish to use as the send centre at the top of the display. For the SMS centres 2 to 4, the setting only applies to the next SMS.

Please note

If you have agreed a flat fixed line network rate with your network operator, the chargeable numbers with dialling code 0900 are often blocked. If, in this case, you enter a 0900 number for the SMS service centre, you will not be able to send text messages from your phone.

Room monitor

When the room monitor is switched on, the stored (internal or external) destination number is called as soon as a defined noise level is exceeded in the vicinity of the handset.

Incoming calls are signalled only via the display, the lighting is reduced to 50%. Vibration alarm, ringtones, advisory tones and paging are switched off.

Caution

- ◆ **Always check the function when switching on (noise sensitivity, connection to an external number).**
Please note that the room monitor is only activated 20 seconds after being switched on.
- ◆ Place the handset **in the charger** so that the front with the microphone is facing the baby and the distance between the handset and the baby is no more than 1 to 2 metres.
- ◆ No answering machine may be activated at the destination number.

Changing the settings:

▶ Menu key ▶ In [Room Monitor] touch [Edit]. ▶ Select the sensitivity (**High or Low**) and the destination for the room monitor call (**External or Internal**). Touch next to **Number**. ▶ Enter the destination number or select the internal number. ▶ Confirm with .
▶ Touch [Save].

Switch on room monitor: ▶ Menu key ▶ [Room Monitor] ▶ Touch the key on the right.

Accept alarm call: ▶ On the destination phone/handset of the alarm call, press the pick-up key or pick up the receiver.

Cancel alarm call: ▶ Press .

Switch off room monitor: ▶ On the handset on which the room monitor is activated, touch the key on the left.

Calendar

You can remind yourself of up to **100 appointments**. Birthdays saved in Contacts are transferred to the calendar. The current day is highlighted in the calendar. Days with appointments are marked with a coloured bar.

Saving appointments to the calendar

Prerequisite: the date and time have already been set.





▶ Menu key ▶ [Calendar]. ▶ Touch / to set the month. ▶ Touch a day and then [New]. ▶ Enter the name, the time of the appointment and the reminder. ▶ Touch / next to **Sound** to switch the audible signal off and on. ▶ Touch [Save].

Setting the tones and volumes of the reminder signal

▶ Menu key ▶ Menu page **Settings**. ▶ [Audio Settings] ▶ Touch next to **Reminder Signal**. ▶ Set the volume and melody. ▶ Save and go back with .

Alarm

Prerequisite: the date and time have already been set.

- ▶ Open the status page. ▶ Touch  **Alarm**.
- ▶ Touch [ **Edit**] to change the settings for the alarm.
- ▶ Set the hour and minute for the wake-up time.
- ▶ Touch the days of the week on which the alarm should ring (orange = selected).
- ▶ Touch  next to **Ringtone**. ▶ Select a ringtone for the alarm call. ▶ Save and go back with .
- ▶ Touch the key to switch the alarm on and off.
- ▶ Touch [ **Save**].

Deactivating the wake-up call/repeating after a pause (snooze mode)

Prerequisite: A wake-up call sounds on the handset.

- ▶ **Deactivate:** Touch **Off**.
- ▶ **Snooze mode:** Touch **Snooze**. The wake-up call is repeated after 5 minutes. After the second repetition, the wake-up call is deactivated completely.

ECO DECT – Reducing transmission power (radiation)

On delivery, the device is set to maximum range. This guarantees optimised wireless management. You can reduce the transmission power further as follows:

Shorten range – Reduces the transmission power by up to 80%



- ▶ Open the status page. ▶ Use the key next to  **Max. Range** to switch the function on/off.

Completely switch off the base wireless signals in idle status (Eco Mode+)

- ▶ Open the status page. ▶ Use the key next to  **No Radiation** to switch the function on/off (on = wireless transmission switched off).

Bluetooth devices

Up to 5 data devices (PC, PDA, mobile phone) and one Bluetooth headset can be registered on the handset. The distance to the Bluetooth device should not exceed 10 m.

- ▶ Open the status page. ▶ Touch  Bluetooth. ▶ The Bluetooth page ( image) is displayed.
 - ▶ Activate/deactivate Bluetooth using the switch next to **Activation**.

Finding and trusting Bluetooth devices





The search starts as soon as the Bluetooth page is opened and Bluetooth has been activated.

- ▶ Touch  next to **Devices found**. ▶ Select device.
 - ▶ Touch [ Trust Device]. ▶ If necessary, enter the PIN of the device. ▶ Confirm with .

Managing known (trusted) devices

- ▶ Touch  next to **Known Devices**.

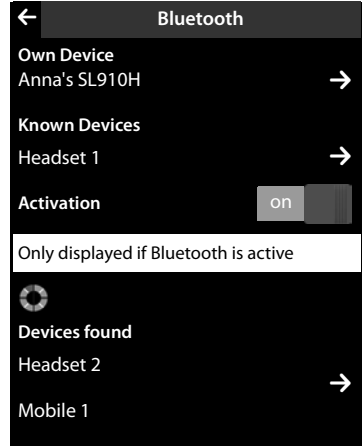

You can:

- ◆ **De-register (delete) devices:** ▶ Touch [ Delete].
 - ▶ Touch  for each device to be de-registered.
 - ▶ Touch [ Delete]. ▶ Confirm with **Yes**.
- ◆ **Change the name of a device:** ▶ Select device.
 - ▶ Enter/change name. ▶ Confirm with .



Rejecting/accepting an unregistered Bluetooth device

An unregistered Bluetooth device is trying to establish a connection (bonding).

- ◆ **Reject:** ▶ Touch  or press .
- ◆ **Accept:** ▶ Enter the PIN of the device. ▶ Confirm with .
 - ▶ Touch **Yes**: Add to the **Known Devices** list, or
 - ▶ Touch **No**: Temporarily use device.

Changing the Bluetooth name of the handset

- ▶ Touch  next to **Own Device**. ▶ Change name and confirm with .

Customer Service & Assistance

Do you have any questions? As a Gigaset customer, you can find help quickly in this User Manual and in the service section of our Gigaset online portal www.gigaset.com/service.

In our constantly updated online service you can find:

- ◆ Extensive information about our products
- ◆ FAQ compilations
- ◆ Keyword search to help find topics quickly
- ◆ Compatibility database: Find out which base stations and handsets can be combined
- ◆ Product comparison: Compare the features of several products with each other
- ◆ Downloads for user manuals and current software updates
- ◆ E-mail contact form for customer service

Please register your phone online right after purchase.

This enables us to provide you with even better service regarding questions or an after sales query/issue/claim. In order to contact our customer service via email, please use the email contact form from our Gigaset online portal after selecting your home country.

Our representatives are also available on the telephone hotlines for consultation.

Customer Service & Assistance

Australia -----	+61 1300 780 878	Jordan -----	00962 6 5625460/1/2
Austria -----	-0043 1 311 3046	Kuwait -----	+965 -22458737/22458738
Bahrain -----	-31 73 11 173	Lebanon -----	+9611240259/
Belgium -----	07815 6679	-----	+9611236110
Bosnia Herzegovina -----	033 276 649	Luxembourg-----	(+352) 8002 3811
Brazil		Malaysia-----	+603-8076 9696
Grandes Capitais e Regiões Metropolitanas:		Malta -----	+39 02360 46111 (0,10 €)
-----	-4003 3020	Mexico -----	-01800 999 4442738
(Preço de uma ligação local)		-----	(01800 999 GIGASET)
-----	Demais localidades:	Netherlands-----	-0900-3333102
-----	-0800 888 3020	New Zealand -----	-0800 780 878
(Gratuito)		Norway -----	+47 2231 0845
Bulgaria -----	+359 2 9710666	Oman-----	+968 70928 Ext. 49/21/75
Canada -----	1-866 247-8758	Poland -----	-801 140 160
China -----	0 21 400 670 6007 (RMB 0.11)	Portugal-----	+351 808 788 877
Croatia -----	01 / 2456 555	-----	(custo de uma chamada local)
Czech Republic-----	233 032 727	Romania -----	+40 021 204 9130
Denmark-----	+45 43682003	Russia -----	8-800 333 4956
Finland -----	+358 (0)9725 19734	Serbia -----	-0800 222 111
France-----	+33 (0)157 324 522	Singapore -----	6735 9100
Germany-----	-01805 333 222	Slovak Republic-----	044 5567 988 alebo
Greece -----	+30 2111 98 1778	-----	02 59682266
Hong Kong -----	-2763 0203	Slovenija -----	-01 5466 511
-----	2389 7285	South Africa-----	0800 98 08 42
Hungary -----	-(06-1) 267 2109 (27 Ft)	Spain -----	- 902 103935
India -----	Please refer to your	Sweden -----	+46 (0)8502 52347
-----	local warranty card	Switzerland -----	-0848 212 000
Indonesia -----	-(62-21) 5673813	Taiwan -----	-02 266 24343
-----	(62-21) 888856000	Turkey -----	+90 216 223 01 57
Ireland -----	+353 818 200 033	Ukraine -----	+380-44-451-71-72
Italy-----	199.15.11.15	United Arab Emirates-----	+97144458255
(€ cent 8,36 + IVA al minuto da telefono fisso		-----	+97144458254
della rete Telecom Italia senza scatto alla		United Kingdom -----	+44 84503 18190
risposta mentre per le chiamate effettuate		USA -----	-1-866 247-8758
attraverso la rete di altri operatori fissi o		-----	tollfree
mobili consultate le tariffe del vostro			
operatore)			

Please have your record of purchase ready when calling. After sales service is not offered in countries where our product is not sold by authorised dealers.

Manufacturer warranty (Middle East)

On the purchase of your new Gigaset product, we guarantee that this equipment is a genuine manufacturer's product and extend the following warranty:

We guarantee this product against manufacturing defects for two full years from the date of purchase, unless specified otherwise.

Adaptors and batteries for cordless phones carry 6 months warranty from the date of purchase.

Gigaset Communications authorized Service Centres will replace or repair, if necessary, any defective part/parts free of charge by presenting this certificate of warranty at the Service Centre mentioned overleaf.

This Certificate of warranty does not apply if the telephone has:

- ◆ Been misused, mishandled, willfully damaged, neglected, damaged by lightning, improperly repaired, tested, altered improperly in any way.
- ◆ A defect arising out of any failure to follow instructions either in the manual or product specification.
- ◆ In case repairs are carried out of by unauthorized personnel or unauthorized source warranty will be void.
- ◆ A defect arising from using non-Gigaset approved accessories or ancillary items attached to or in connection with the telephone.
- ◆ If this certificate of warranty is not signed and stamped by the authorized distributor.
- ◆ Any other claim resulting out of or in connection with the device shall be excluded from this warranty.

For Southern Africa:

In the event of an after-sales issue/warranty claim please refer back to your point of purchase.

Proof of purchase (receipt) has to be submitted.

Certificate of warranty (Middle East)

The warranty is not valid if it is not signed and stamped by the authorized distributor.

Please fill in the following details and stamp the card to validate the warranty.

All details must be filled in by the dealer and retained by the customer.

This warranty shall apply to products purchased in the Middle East only.

Customer's Name: _____

Product / Model: _____

Dealer's Name: _____

Date of Purchase: _____

Invoice / Cash Memo Details: _____

Dealer's Stamp

Service Centres (Midde East)

UAE

Customer Service Hotline UAE

TEL: 00971-4-4458255 / 00971-4-4458254

Service Collection Point

www.technocare-prodigy.com

KARAMA

Sea Shell Electronics

Opp. Karama Centre

Dubai, UAE

Tel: 00971-4-3979228

Fax: 00971-4-3966205

Deira

Souvenir Mobiles,

Omar Bin Katab Road,

Oppst. Gulf Peral hotel (Tahir Hotel)

Al Baraha Street,

Tel: 00971-4-2731910 / 00971-4-2737377

Sharjah

Hotline Telecom

Sahara Centre

Sharjah, UAE

Tel: 00971-6-5312126

Al Ain

Phone Station

Al Ain Mall, Town Centre,

Tel: 00971-3-7515588

Fujairah

Al Manzil,

Al Gurfa Street,

Main market Road,

Tel: 00971-9-2233488

Oman

National Telephone Services Co. LLC

P.O. Box 2786 PC:112, Sultanate of Oman

Tel: +968-709281 Ext. 45/21/75

Fax: +968-791013

E-mail: isonts@omentel.net.om

Qatar

Modern Home,

51-East - Salwa Road,

Al-Maha Complex, Doha

Tel: 00974-4257844 / 00974-4257777

Fax: 00974-4314700

Bahrain

Authorized Service Center,

Bldg: 211, Rd: 339, Block: 321,

Old Place Road, Manama,

Tel: 00973-17311173

E-mail: servicemanager@ashrafs.com.bh

Saudi Arabian Service Centers:

Ahmed Abdulwahed Trading Co.

Jeddah Service Center

Al-Amal Plaza, Hail Street,
Jeddeh, Saudi Arabia,
Tel: 02-6500282 Ext. 209

Riyadh Service Center

Olaya Street
Riyadh, Saudi Arabia,
Tel: 01-4622470 / 4623850

Khobar Service Centre

Al-Khobar Street,
Al-Khobar, Saudi Arabia,
Tel: 03-8944193/03-8952359

Madina Munawara

Al-Ayon Street,
Tel: 00966-4-8387931

Khamis Mushyat

Al-Khalidiya St.,
Tel: 00966-7-2230772

Tabuk

Main Street,
Tel: 00966-4-4219232

Please note

Signs of wear on the display and housing are excluded from the warranty.

Authorisation

This device is intended for analogue phone lines outside the European Economic Area (with the exception of Switzerland) depending on national type approval.

Country-specific requirements have been taken into consideration.

We, Gigaset Communications GmbH, declare that this device meets the essential requirements and other relevant regulations laid down in Directive 1999/5/EC.

A copy of the Declaration of Conformity is available at this Internet address:
www.gigaset.com/docs

CE 0682

Kuwait

Customer Service Hotline Kuwait

Tel: 00965-22458737 / 00965-22458738
Al-Baptain Service Center
Shop #: 247
Qibla, Block 11,
Avenue 11,
Souk al Kabeer,
Fahad Al Salem Street,
Tel: 00965-2464993

Jordan

SEDR Home & office Electronics
Co - Tronicom
Wasfi Al-Tal St.,
Building No. 80,
2nd floor,
Tel: 00962-6-5625460/1/2

Lebanon

306, Jdeideh Sin el Fil Blvd,
Tel: 00961-1240259 / 00961-1236110

Index

A

- Activating
 - answering machine 22
 - two-way recording 24
- Activating/deactivating
 - answering machine 23
 - Bluetooth 37
 - function 27
 - room monitor 35
- Alarm 36
- Alarm call 36
- Announcement (answering machine) ... 22
- Answering machine 22
 - activating/deactivating 22
 - deleting messages 23
 - playing back messages 23
 - recording 24
 - recording a personal announcement/
advisory message 22
 - time control 22
- Area code - prefix 13
- Arrow in option slider 26
- Authorisation 42
- Auto answer 20, 29

B

- Back function 27
- Base
 - connecting to power/telephone
network 6
 - setting 9
 - setting up 5
 - variants 1 and 2 2
 - wall mounting 7
- Battery
 - charging 9
 - inserting 8
- Birthday 31
 - saving in Contacts 31
- Bluetooth
 - activating 37
 - changing device name 37
 - known devices 37
 - registering device 37
 - rejecting device 37
 - trusted devices 37

C

- Calendar 35
- Call
 - accepting 29
 - anonymous 30
 - diverting 30
 - diverting (ans. mach.) 24
 - external 29
 - internal 29
 - picking up from answering machine .. 24
 - recording 24
 - redirecting (ans. mach.) 24
- Call screening during recording
(ans. mach.) 23
- Call swapping 30
- Calling
 - external 29
 - internal 29
- Calling Line Identification 30
- Changing device name (Bluetooth) 37
- Changing settings
 - user interface elements 27
- Character set
 - changing 28
 - Cyrillic 28
 - Greek 28
 - keypad layout 28
- Charger (handset)
 - setting up 5
- Charger cradle (handset)
 - connecting 7
- Charging contacts 1
- Cloud synchronisation 15
- Conference 30
- Configurable page 32
- Configuring QuickDial 32
- Connecting the phone cable 6
- Connecting the power cable 6
- Consultation call 30
- Contacts 31
 - copying number 32
 - creating entry 31
 - deleting entry 31
 - managing entries 31
 - opening 29, 31
 - saving birthdays 31
 - saving entry 31
 - sending entry/list to handset 32
 - sending to handset 32

Index

- Correcting incorrect entries 28
- Customer Care 38
- Customer Service & Assistance 38
- D**
- Deactivating
 - answering machine 22
 - two-way recording 24
- Default number 29, 31
- Deleting
 - announcement for answering machine 22
 - Contacts entry 31
 - message (answering machine) 23
 - QuickDial. 32
- Deleting (text message) 34
- Destination number (room monitor) 35
- Device
 - changing name (Bluetooth) 37
 - registering (Bluetooth) 37
 - rejecting (Bluetooth) 37
 - trusting (Bluetooth) 37
- Dial page (idle display) 29
- Dialling
 - using the messages list 29
 - using the redial list 29
 - with Contacts 29
 - with selection field 29
- Display icons. 16
- Display lock
 - automatic 25
 - switching on/off 25
- Diverting a call
 - to answering machine. 24
- E**
- Earpiece mode 30
- Earpiece volume 30
- ECO DECT 36
- Eco mode + (switching off wireless module) 36
- End call/end key 1
- End call/end key s. Poster
- End key, see End call/end key
- Entering diacritical characters 28
- Entering special characters. 28
- Entering special letters 28
- Entering text. 28
- Entering umlauts. 28
- Entry in Contacts 31
- External call
 - diverting to answering machine. 24
- F**
- Function
 - activating/deactivating 27
 - selecting 25
- G**
- Getting started 5
- H**
- Handset
 - activating/deactivating 25
 - connecting charger cradle 7
 - earpiece volume 30
 - idle status 14, 25
 - muting 30
 - registering 9
 - setting 9
 - setting up 8
 - speaker volume. 30
 - using room monitor 35
- Handsfree volume. 30
- Hearing aids 4
- I**
- Icons
 - options bar 16
- Idle status
 - handset s. Poster
 - returning to 25
- Incoming message list (SMS) 34
- Incorrect entry correction. 28
- Installation wizard. 9
- Internal call 29
- K**
- Key lock
 - activating/deactivating 25
 - automatic 25
- Keypad layout 28
- Keypad/display lock on/off. 1

- Keys**
- end call/end key1
 - end call/end keys. Poster
 - handset1
 - menu keys. Poster
 - paging key (base)2
 - talk key1
 - talk keys. Poster
- L**
- List**
- cleaning up.....23, 31, 34
 - known devices (Bluetooth)..... 37
 - scrolling in 26
 - selecting entry..... 25
- Lock**
- automatic 25
 - switching on/off 25
- Lower/upper case 28**
- M**
- Main menu settings 17
 - Making calls
 - accepting a call 29
 - external 29
 - internal 29
 - Making internal calls 29
 - Manufacturer warranty (Middle East) ... 40
 - Medical equipment4
 - Menu key.....1
 - Menu keys. Poster
 - Menu settings 17
 - Message LED1
 - Message length (ans. mach.) 23
 - Messages
 - delete (ans. mach.) 23
 - playing back (ans. mach.) 23
 - Messages list..... 29
 - Microphone sensitivity 30
 - Mini USB connection socket.....1
 - Mounting the base on the wall7
 - Muting the handset 30
- N**
- Navigation area1
 - Network services, provider-specific 30
 - Number
 - as destination for room monitor..... 35
 - copying to Contacts 32
 - saving in Contacts 31
 - Numbers
 - entering..... 28
- O**
- Opening the submenu 27
 - Opening/closing the battery cover8
 - Option slider
 - showing/hiding..... 26
 - Options 26
 - Options bar..... 26
 - icons..... 16
 - Overview
 - setting options 17
 - telephone and operation s. Poster
- P**
- Package contents5
 - Paging2
 - Paging key.....2
 - Parameter 27
 - Playing back
 - announcement (answering machine) . 22
 - message (answering machine) 23
 - Power adapter4
 - Prefix for area code..... 13
 - Proximity sensor1
 - Proximity sensor s. Poster, 25
- Q**
- QuickDial icon 32
 - QuickDial shortcut 33
- R**
- Radiation..... 36
 - Range.....5
 - reducing 36

Index

Recording	
announcements (answering machine).....	22
two-way recording.....	24
Recording (ans. mach.).....	24
Recording quality (ans. mach.).....	23
Redirecting (ans. mach.).....	24
Registering	
handset.....	9
Registration mode.....	2
Reminder signal.....	35
Ring delay	
answering machine.....	23
automatic.....	20, 29
Room monitor.....	35
S	
Safety precautions.....	4
Scrolling	
horizontally.....	26
in lists.....	26
vertical.....	26
Searching for Bluetooth devices.....	37
Selection fields.....	27
Sending	
complete Contacts to handset.....	32
Contacts entry to handset.....	32
SMS.....	33
Service Centres (Midde East).....	41
Setting an appointment.....	35
Setting options	
answering machine.....	22
overview.....	17
Setting the area code.....	9
Setting the country.....	9
Setting the date.....	9
Setting the display language.....	9
Setting the time.....	9
Setting up	
base.....	5
handset.....	8
Settings menu.....	17
SMS.....	33
active send.....	34
sending.....	33
writing.....	33

SMS centre	
changing number.....	34
setting.....	34
Snooze mode (alarm).....	36
Speaker.....	30
Status bar.....	1
Switch.....	27
Switching microphone (handset)	
on/off.....	30
Switching off wireless module.....	36
Switching on/off	
alarm.....	36
answering machine.....	23
function.....	27
Synchronising Contacts.....	15
Synchronising Google contacts.....	15

T

Talk key.....	1
Talk key.....	s. Poster
Text message, see SMS	
Time control (ans. mach.).....	22
Touchscreen.....	1
operating.....	25
Transferring a call	
to another number.....	30

U

Upper/lower case.....	28
USB connection socket.....	1
User interface elements.....	27
Using the redial list.....	29
Using the telephone.....	25

V

Vertical scrolling.....	26
VIP ringtone.....	31
Volume	
handsfree/earpiece volume of handset.....	30

W

Withholding number.....	30
Writing (SMS).....	33

Issued by

Gigaset Communications GmbH
Frankenstr. 2a, D-46395 Bocholt

© Gigaset Communications GmbH 2012

Subject to availability.

All rights reserved. Rights of modification reserved.

www.gigaset.com