

## SIMATIC NET

### Industrial Ethernet Switches SCALANCE X-200

#### Operating Instructions

#### Introduction

---

Safety notices

---

1

Recommendations on  
network security

---

2

Description of the device

---

3

Installation

---

4

Connecting up

---

5

Technical specifications

---

6

Approvals

---

7

Dimension drawings

---

A

Test of mechanical stability

---

B

## Legal information

### Warning notice system

This manual contains notices you have to observe in order to ensure your personal safety, as well as to prevent damage to property. The notices referring to your personal safety are highlighted in the manual by a safety alert symbol, notices referring only to property damage have no safety alert symbol. These notices shown below are graded according to the degree of danger.

<b>⚠ DANGER</b>
indicates that death or severe personal injury <b>will</b> result if proper precautions are not taken.

<b>⚠ WARNING</b>
indicates that death or severe personal injury <b>may</b> result if proper precautions are not taken.

<b>⚠ CAUTION</b>
indicates that minor personal injury can result if proper precautions are not taken.

<b>NOTICE</b>
indicates that property damage can result if proper precautions are not taken.

If more than one degree of danger is present, the warning notice representing the highest degree of danger will be used. A notice warning of injury to persons with a safety alert symbol may also include a warning relating to property damage.

### Qualified Personnel

The product/system described in this documentation may be operated only by **personnel qualified** for the specific task in accordance with the relevant documentation, in particular its warning notices and safety instructions. Qualified personnel are those who, based on their training and experience, are capable of identifying risks and avoiding potential hazards when working with these products/systems.

### Proper use of Siemens products

Note the following:

<b>⚠ WARNING</b>
Siemens products may only be used for the applications described in the catalog and in the relevant technical documentation. If products and components from other manufacturers are used, these must be recommended or approved by Siemens. Proper transport, storage, installation, assembly, commissioning, operation and maintenance are required to ensure that the products operate safely and without any problems. The permissible ambient conditions must be complied with. The information in the relevant documentation must be observed.

### Trademarks

All names identified by ® are registered trademarks of Siemens AG. The remaining trademarks in this publication may be trademarks whose use by third parties for their own purposes could violate the rights of the owner.

### Disclaimer of Liability

We have reviewed the contents of this publication to ensure consistency with the hardware and software described. Since variance cannot be precluded entirely, we cannot guarantee full consistency. However, the information in this publication is reviewed regularly and any necessary corrections are included in subsequent editions.

# Introduction

## Purpose of the Operating Instructions

These operating instructions support you when commissioning networks with the devices of the product line SCALANCE X-200.

## Validity of the Operating Instructions

These Operating Instructions apply to the following devices:

<b>SCALANCE X-200 and SCALANCE XF-200</b>	
<b>Device</b>	<b>Article number</b>
X204-2	6GK5 204-2BB10-2AA3
X204-2TS	6GK5 204-2BB10-2CA2
X204-2FM	6GK5 204-2BB11-2AA3
X204-2LD	6GK5 204-2BC10-2AA3
X204-2LD TS	6GK5 204-2BC10-2CA2
X206-1	6GK5 206-1BB10-2AA3
X206-1LD	6GK5 206-1BC10-2AA3
X208	6GK5 208-0BA10-2AA3
X208PRO	6GK5 208-0HA10-2AA6
X212-2	6GK5 212-2BB00-2AA3
X212-2LD	6GK5 212-2BC00-2AA3
X216	6GK5 216-0BA00-2AA3
X224	6GK5 224-0BA00-2AA3
Flat design:	
XF204	6GK5 204-0BA00-2AF2
XF204-2	6GK5 204-2BC00-2AF2
XF206-1	6GK5 206-1BC00-2AF2
XF208	6GK5 208-0BA00-2AF2

<b>SCALANCE X-200IRT and XF-200IRT</b>	
<b>Device</b>	<b>Article number</b>
X200-4P IRT	6GK5 200-4AH00-2BA3
X201-3P IRT	6GK5 201-3BH00-2BA3
X201-3P IRT PRO	6GK5 201-3JR00-2BA6
X202-2IRT	6GK5 202-2BB00-2BA3
X202-2P IRT	6GK5 202-2BH00-2BA3
X202-2P IRT PRO	6GK5 202-2JR00-2BA6

SCALANCE X-200IRT and XF-200IRT	
Device	Article number
X204IRT	6GK5 204-0BA00-2BA3
X204IRT PRO	6GK5 204-0JA00-2BA6
Flat design:	
XF204IRT	6GK5 204-0BA00-2BF2
XF204-2BA IRT *)	6GK5 204-2AA00-2BD2

\*) Basic device without bus adapter

Premounted variants			
Device	Article number	Components	Component article numbers
XF201-3P IRT	6GK5 201-3BH00-2BD2	1 basic device XF204-2BA IRT	6GK5 204-2AA00-2BD2
		1 bus adapter BA 2xSCRJ	6ES7 193-6AP00-0AA0
		1 bus adapter BA SCRJ/ RJ-45	6ES7 193-6AP20-0AA0
XF202-2P IRT	6GK5 202-2BH00-2BD2	1 basic device XF204-2BA IRT	6GK5 204-2AA00-2BD2
		2 bus adapters BA SCRJ/ RJ-45	6ES7 193-6AP20-0AA0

Unless mentioned otherwise, the descriptions in these operating instructions refer to all devices of the SCALANCE X-200 product group named above in the section on validity.

### Designations used

Classification	Description	Terms used
Product line	For all devices and variants of all product groups within the SCALANCE X-200 product line, the term X-200 IE switches is used.	X-200 IE switches
Product group	For all devices and variants of a product group, only the product group is used.	SCALANCE X-200
Device	For a device, only the device name is used.	e.g. SCALANCE X204-2

### See also

60243748 (<https://support.industry.siemens.com/cs/ww/en/view/60612658>)

27069465 (<https://support.industry.siemens.com/cs/ww/en/view/27069465>)

84922825 (<https://support.industry.siemens.com/cs/ww/en/view/84922825>)

39134641 (<http://www.siemens.de/snst>)

SIMATIC ET 200SP Manual Collection (<https://support.industry.siemens.com/cs/ww/en/ps/man>)

## Documentation on configuration

You will find detailed information on configuring the devices in the configuration manual:

- SIMATIC NET Industrial Ethernet switches SCALANCE X-200 Configuration Manual

You will find the Configuration Manual here:

- On the data medium that ships with some products:
  - Product CD / product DVD
  - SIMATIC NET Manual Collection
- On the Internet pages of Siemens Industry Online Support (<https://support.industry.siemens.com/cs/ww/en/ps/15247>).

## Further documentation

In the system manuals "Industrial Ethernet / PROFINET Industrial Ethernet" and "Industrial Ethernet / PROFINET passive network components", you will find information on other SIMATIC NET products that you can operate along with the devices of this product line in an Industrial Ethernet network.

There, you will find among other things optical performance data of the communications partner that you require for the installation.

You will find the system manuals here:

- On the data medium that ships with some products:
  - Product CD / product DVD
  - SIMATIC NET Manual Collection
- On the Internet pages of Siemens Industry Online Support:
  - Industrial Ethernet / PROFINET Industrial Ethernet System Manual (<https://support.industry.siemens.com/cs/ww/en/view/27069465>)
  - Industrial Ethernet / PROFINET Passive Network Components System Manual (<https://support.industry.siemens.com/cs/ww/en/view/84922825>)

## SIMATIC NET manuals

You will find the SIMATIC NET manuals here:

- On the data medium that ships with some products:
  - Product CD / product DVD
  - SIMATIC NET Manual Collection
- On the Internet pages of Siemens Industry Online Support (<https://support.industry.siemens.com/cs/ww/en/ps/15247>).

## SIMATIC NET glossary

Explanations of many of the specialist terms used in this documentation can be found in the SIMATIC NET glossary.

You will find the SIMATIC NET glossary here:

- SIMATIC NET Manual Collection or product DVD  
The DVD ships with certain SIMATIC NET products.
- On the Internet under the following address:  
50305045 (<https://support.industry.siemens.com/cs/ww/en/view/50305045>)

## Security information

Siemens provides products and solutions with industrial security functions that support the secure operation of plants, systems, machines and networks.

In order to protect plants, systems, machines and networks against cyber threats, it is necessary to implement – and continuously maintain – a holistic, state-of-the-art industrial security concept. Siemens' products and solutions constitute one element of such a concept.

Customers are responsible for preventing unauthorized access to their plants, systems, machines and networks. Such systems, machines and components should only be connected to an enterprise network or the internet if and to the extent such a connection is necessary and only when appropriate security measures (e.g. firewalls and/or network segmentation) are in place.

For additional information on industrial security measures that may be implemented, please visit

<https://www.siemens.com/industrialsecurity> (<https://www.siemens.com/industrialsecurity>)

Siemens' products and solutions undergo continuous development to make them more secure. Siemens strongly recommends that product updates are applied as soon as they are available and that the latest product versions are used. Use of product versions that are no longer supported, and failure to apply the latest updates may increase customers' exposure to cyber threats.

To stay informed about product updates, subscribe to the Siemens Industrial Security RSS Feed under

<https://www.siemens.com/industrialsecurity> (<https://www.siemens.com/industrialsecurity>)

## Catalogs

You will find the article numbers for the Siemens products of relevance here in the following catalogs:

- SIMATIC NET Industrial Communication / Industrial Identification, catalog IK PI
- SIMATIC Products for Totally Integrated Automation and Micro Automation, catalog ST 70
- Industry Mall - catalog and ordering system for automation and drive technology, Online catalog (<https://mall.industry.siemens.com/goos/WelcomePage.aspx?regionUrl=/en&language=en>)

You can request the catalogs and additional information from your Siemens representative.

## Device defective

If a fault develops, please send the device to your SIEMENS service center for repair. Repairs on-site are not possible.

## Recycling and disposal

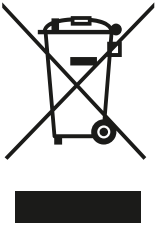

The products are low in pollutants, can be recycled and meet the requirements of the WEEE directive 2012/19/EU for the disposal of electrical and electronic equipment.

Do not dispose of the products at public disposal sites.

For environmentally friendly recycling and the disposal of your old device contact a certified disposal company for electronic scrap or your Siemens contact (Product return (<https://support.industry.siemens.com/cs/ww/en/view/109479891>)).

Note the different national regulations.

## Trademarks

The following and possibly other names not identified by the registered trademark sign ® are registered trademarks of Siemens AG:

SIMATIC NET, SCALANCE, C-PLUG, OLM

## Electrostatic discharge



### NOTICE

#### Electrostatic sensitive devices (ESD)

Electronic modules contain electrostatic sensitive components

These components can easily be destroyed if handled incorrectly.

Note the following instructions to avoid damage.

- Touch electronic modules only when you absolutely need to work on them.
- If electronic modules need to be touched, the body of the person involved must first be electrostatically discharged and grounded.
- Do not bring electronic modules in contact with electrically isolating materials such as plastic film, isolating table top pads or clothing made of synthetic fibers.
- Place the modules only on conductive surfaces.
- Pack, store and transport electronic modules and components only in conductive packaging such as metalized plastic or metal containers, conductive foam or household aluminum foil.





# Table of contents

	Introduction .....	3
<b>1</b>	<b>Safety notices .....</b>	<b>11</b>
<b>2</b>	<b>Recommendations on network security .....</b>	<b>13</b>
<b>3</b>	<b>Description of the device .....</b>	<b>17</b>
3.1	Functions .....	17
3.2	Product overview .....	20
3.3	Device views .....	22
3.4	Accessories .....	24
3.5	The LEDs .....	27
3.5.1	LED display when the device starts up .....	27
3.5.2	Power LED "L" (green/yellow LED) .....	27
3.5.3	Fault LED "F" (yellow/red LED) .....	27
3.5.4	Redundancy manager LED "RM" (green LED) .....	28
3.5.5	Standby LED "RM" (yellow LED) .....	29
3.5.6	Port LEDs "P" (green/yellow LEDs) .....	29
3.5.7	Diagnostics LEDs for optical connectors "F" (yellow LED) .....	30
3.5.8	Show Location .....	30
3.6	The SET button .....	31
3.7	The C-PLUG .....	32
3.8	Starting the device for the first time .....	35
<b>4</b>	<b>Installation .....</b>	<b>37</b>
4.1	Safety notices for installation .....	37
4.2	Installation options .....	41
4.3	Installation on a DIN rail .....	42
4.4	Mounting onto standard rail (SCALANCE XF204-2BA IRT) .....	43
4.5	Installation on a standard rail .....	45
4.6	Wall mounting .....	46
4.7	Mounting bus adapters .....	47
<b>5</b>	<b>Connecting up .....</b>	<b>49</b>
5.1	Safety when connecting up .....	49
5.2	Wiring rules .....	52
5.3	Power supply .....	53
5.3.1	Supply with X-200 via the terminal block .....	53
5.3.2	Supply for X208PRO .....	54
5.3.3	Supply for IRT-PRO devices .....	54

5.3.4	Supply with XF-200IRT devices with bus adapter slots .....	56
5.4	Grounding .....	58
5.5	Signaling contact.....	59
5.6	Attachment to Industrial Ethernet.....	61
5.6.1	Electrical connections .....	61
5.6.1.1	Electrical attachments to Industrial Ethernet.....	61
5.6.1.2	Electrical connectors of the X208PRO .....	63
5.6.2	Optical attachments to Industrial Ethernet .....	64
5.6.2.1	Multimode fiber-optic cable .....	65
5.6.2.2	Single mode fiber-optic cable .....	65
5.6.2.3	POF and PCF cables .....	66
5.6.3	Push-pull connector for IRT-PRO devices .....	67
<b>6</b>	<b>Technical specifications.....</b>	<b>69</b>
<b>7</b>	<b>Approvals.....</b>	<b>81</b>
<b>A</b>	<b>Dimension drawings .....</b>	<b>91</b>
<b>B</b>	<b>Test of mechanical stability .....</b>	<b>97</b>
	<b>Index.....</b>	<b>99</b>

# Safety notices

## Read the safety notices

Note the following safety notices. These relate to the entire working life of the device.

You should also read the safety notices relating to handling in the individual sections, particularly in the sections "Installation" and "Connecting up".

 <b>CAUTION</b>
--

To prevent injury, read the manual before use.
--

## Safety notices on use in hazardous areas

### General safety notices relating to protection against explosion

 <b>WARNING</b>
---

<b>EXPLOSION HAZARD</b>
-------------------------

Do not open the device when the supply voltage is turned on.
--

### Safety notices when using the device according to Hazardous Locations (HazLoc) and FM.

If you use the device under HazLoc or FM conditions you must also keep to the following safety notices in addition to the general safety notices for protection against explosion:

This equipment is suitable for use in Class I, Division 2, Groups A, B, C and D or non-hazardous locations only.

This equipment is suitable for use in Class I, Zone 2, Group IIC or non-hazardous locations only.



## Recommendations on network security

### NOTICE

#### Information security

Connect to the device and change the standard passwords for the users "admin" and "user" before you operate the device. To be able to change passwords you need to be logged in with write access to the configuration data.

To prevent unauthorized access, note the following security recommendations.

### General

- You should make regular checks to make sure that the device meets these recommendations and/or other security guidelines.
- Evaluate your plant as a whole in terms of security. Use a cell protection concept with suitable products (<https://www.industry.siemens.com/topics/global/en/industrial-security/Seiten/default.aspx>).
- When the internal and external network are disconnected, an attacker cannot access internal data from the outside. Therefore operate the device only within a protected network area.
- For communication via non-secure networks use additional devices with VPN functionality to encrypt and authenticate the communication.
- Terminate management connections correctly (WBM, Telnet, SSH etc.).

### Physical access

- Restrict physical access to the device to qualified personnel because the plug-in data medium can contain sensitive data.
- Lock unused physical interfaces on the device. Unused interfaces can be used to gain access to the plant without permission.

### Software (security functions)

- Keep the firmware up to date. Check regularly for security updates for the device. You can find information on this at the Industrial Security website.
- Inform yourself regularly about security recommendations published by Siemens ProductCERT.
- Only activate protocols that you require to use the device.
- Restrict access to the management of the device with rules in an access control list (ACL).

- The option of VLAN structuring provides protection against DoS attacks and unauthorized access. Check whether this is practical or useful in your environment.
- Use a central logging server to log changes and accesses. Operate your logging server within the protected network area and check the logging information regularly.

### See also

[www.siemens.com/industrialsecurity](http://www.siemens.com/industrialsecurity) (<http://www.siemens.com/industrialsecurity>)

<http://www.siemens.com/cert/en/cert-security-advisories.htm> (<http://www.siemens.com/cert/en/cert-security-advisories.htm>)

### Passwords

- Define rules for the assignment of passwords.
- Regularly change your passwords to increase security.
- Use passwords with a high password strength.
- Make sure that all passwords are protected and inaccessible to unauthorized persons.
- Do not use the same password for different users and systems.

### Certificates and keys

- On the device there is a preset SSL certificate with key. Replace this certificate with a self-made certificate with key. We recommend that you use a certificate signed either by a reliable external or by an internal certification authority.
- Use a certification authority including key revocation and management to sign certificates.
- Make sure that user-defined private keys are protected and inaccessible to unauthorized persons.
- It is recommended that you use password-protected certificates in the PKCS #12 format
- Verify certificates and fingerprints on the server and client to prevent "man in the middle" attacks.
- It is recommended that you use certificates with a key length of at least 2048 bits.
- Change certificates and keys immediately, if there is a suspicion of compromise.

## Secure/non-secure protocols

- Avoid or disable non-secure protocols, for example Telnet and TFTP. For historical reasons, these protocols are available, however not intended for secure applications. Use non-secure protocols on the device with caution.
- Check whether use of the following protocols and services is necessary:
  - Non authenticated and unencrypted ports
  - MRP, HRP
  - LLDP
  - DHCP Options 66/67

The following protocols provide secure alternatives:

- HTTP → HTTPS
- TFTP → FTPS
- Telnet → SSH
- SNTP → NTP
- SNMPv1/v2c → SNMPv3

Check whether use of SNMPv1/v2c. is necessary. SNMPv1/v2c are classified as non-secure. Use the option of preventing write access. The device provides you with suitable setting options.

If SNMP is enabled, change the community names. If no unrestricted access is necessary, restrict access with SNMP.

Use the authentication and encryption mechanisms of SNMPv3.

- Use secure protocols when access to the device is not prevented by physical protection measures.
- If you require non-secure protocols and services, operate the device only within a protected network area.
- Restrict the services and protocols available to the outside to a minimum.
- For the DCP function, enable the "DCP read-only" mode after commissioning.

## Available protocols

The following list provides you with an overview of the open protocol ports.

The table includes the following columns:

- **Protocol**
- **Port**
- **Default port status**
  - Open  
The factory setting of the port is "Open".
  - Closed  
The factory setting of the port is "Closed".

- **Configurable port**
  - ✓  
The port status can be changed.
  - --  
The port status cannot be changed.
- **Authentication**  
Specifies whether the communication partner is authenticated.
- **Encryption**  
Specifies whether or not the transfer is encrypted.

Protocol	Port number	Port status	Factory setting	Authentication	Encryption
SSH	TCP/22	Open	Open	Yes	Yes
HTTP	TCP/80	Open	Open	Yes	No
HTTPS	TCP/443	Open	Open	Yes	Yes
SNTP NTP (secure)	UDP/123	Open (when configured)	Closed	No	Yes No
SNMP	UDP/161	Open (when configured)	Open	Yes	Yes (SNMPv3)
PROFINET IO	UDP/34964 UDP/1026, UDP/1027 *)	Open	Open	No	No
PROFINET IO Service	TCP/84	Open	Open	No	No
TELNET	TCP/23	Open (when configured)	Open	Yes	No
DHCP	UDP/67, UDP/68	Open (when configured)	Closed	No	No
TFTP	UDP/69	Open (when configured)	Closed	No	No

\*) These ports are assigned dynamically and can differ from the values specified here.



## Description of the device

### 3.1 Functions

#### Functions of the X-200 IE Switches

The X-200 IE switches are ideally suited for setting up Industrial Ethernet networks in bus, star and ring structures with transmission rates of 10/100 Mbps. All X-200 switches operate in the SIMATIC environment.

##### Hardware properties:

- X devices have a rugged metal housing and can be installed on a DIN rail, a standard rail or directly on a wall.
- XF devices have a plastic housing and a flat design. They are suitable for installation on a DIN rail.
- Redundant power supply, 2 x 24 VDC (exception: IRT-PRO devices)
- Diagnostics LED
- Signaling contact
- SET button for local configuration of the signaling contact
- Slot for C-PLUG
- Reliable plug-in connections thanks to rugged device connectors suitable for industry in conjunction with PROFINET-compliant FastConnect plugs.
- TS devices have varnished printed circuit boards (conformal coating) and meet the requirements of the railway standard EN 50155

##### Software properties:

- PROFINET Diagnostics
- Topology support (LLDP)
- CLI - Command Line Interface / Telnet
- WBM - Web Based Management
- Configuration with STEP 7
- SNMP
- Ring redundancy including redundancy manager
- Passive Listening
- FM devices support the Fiber Monitoring Protocol and allow the monitoring of optical line sections.

### 3.1 Functions

#### Special features of the X-200IRT IE switches

The IRT variants were designed specifically for setting up Industrial Ethernet networks with isochronous/clock synchronous real-time communication. In addition to the properties named above, the IRT switches also provide the following functions:

- IRT communication based on the combination of the switching methods cut through and store and forward.
- Fast media redundancy thanks to an integrated redundancy manager for Fast Ethernet.
- Standby redundancy

#### Special features of the PRO variants

The devices with the "PRO" supplement are designed with degree of protection IP65 or IP67 for use outside a cabinet.

#### Frame delay times

The number of IE Switches X-200 connected in a line influences the frame delay.

---

##### Note

##### Frame delay time with X-200 without IRT

When a frame passes through X-200 IE switches, it is delayed by the Store&Forward function of the X-200 IE switches.

- With a 64 byte frame length by approx. 10 microseconds (at 100 Mbps).
- With a 1500 byte frame length by approx. 130 microseconds (at 100 Mbps).

This means that the more IE Switch X-200 devices the frame passes through, the longer the frame delay.

---

##### Note

##### Frame delay time with X-200 with IRT

The more X-200IRT IE switches a frame runs through, the higher the frame delay. By using the "cut through" switching mechanism, the X-200IRT IE switches are ideal to meet the real-time requirements of PROFINET.

Cut through is, however, not possible:

- Between a port set to 10 Mbps and a port set to 100 Mbps.
  - When two packets are to be sent at the same time on one port.  
In this case, an X-200 IE switch changes to Store&Forward and the delay increases.
-

### Overview of the functions

The following table shows the hardware and software properties for each product variant of the X-200 switches in detail:

Device type	Hardware										Software											
	Flat design	Compact housing	LED diagnostics	SIMATIC environment	Redundant Power supply	Signaling contact	SET button	Slot for C-PLUG	Slots for bus adapters	Railway approval	PROFINET diagnostics	Topology support (LLDP)	Comman Line Interface (CLI) / Telnet	Web Based Management (WBM)	Configuration with STEP 7	SNMP	Ring redundancy incl. redundancy manager	Standby redundancy	IRT communication	Passive Listening	Fiber Monitoring Protocol	
SCALANCE X-200	X204-2		•	•	•	•	•	•	•			•	•	•	•	•	•			•		
	X204-2TS		•	•	•	•	•	•	•		•	•	•	•	•	•	•			•		
	X204-2FM		•	•	•	•	•	•	•			•	•	•	•	•	•			•	•	
	X204-2LD		•	•	•	•	•	•	•			•	•	•	•	•	•			•		
	X204-2LD TS		•	•	•	•	•	•	•		•	•	•	•	•	•	•			•		
	X206-1		•	•	•	•	•	•	•			•	•	•	•	•	•			•		
	X206-1LD		•	•	•	•	•	•	•			•	•	•	•	•	•			•		
	X208		•	•	•	•	•	•	•			•	•	•	•	•	•			•		
	X208PRO		•	•	•	•	•	•	•			•	•	•	•	•	•			•		
	X212-2		•	•	•	•	•	•	•			•	•	•	•	•	•			•		
	X212-2LD		•	•	•	•	•	•	•			•	•	•	•	•	•			•		
	X216		•	•	•	•	•	•	•			•	•	•	•	•	•			•		
	X224		•	•	•	•	•	•	•			•	•	•	•	•	•			•		
	XF204	•		•	•	•	•	•	•			•	•	•	•	•	•			•		
	XF204-2	•		•	•	•	•	•	•			•	•	•	•	•	•			•		
	XF206-1	•		•	•	•	•	•	•			•	•	•	•	•	•			•		
	XF208	•		•	•	•	•	•	•			•	•	•	•	•	•			•		
	SCALANCE X-200IRT	X200-4P IRT		•	•	•	•	•	•			•	•	•	•	•	•		•	•	•	
X201-3P IRT			•	•	•	•	•	•			•	•	•	•	•	•		•	•	•		
X201-3P IRT PRO			•	•	•	•	•	•			•	•	•	•	•	•		•	•	•		
X202-2IRT			•	•	•	•	•	•			•	•	•	•	•	•		•	•	•		
X202-2P IRT			•	•	•	•	•	•			•	•	•	•	•	•		•	•	•		
X202-2P IRT PRO			•	•	•	•	•	•			•	•	•	•	•	•		•	•	•		
X204IRT			•	•	•	•	•	•	•			•	•	•	•	•	•		•	•	•	
X204IRT PRO			•	•	•	•	•	•	•			•	•	•	•	•	•		•	•	•	
XF204IRT		•		•	•	•	•	•	•			•	•	•	•	•	•		•	•	•	
XF204-2BA IRT		•		•	•	•	•	•	•	•		•	•	•	•	•	•		•	•	•	

• applies

### Number of electrical and optical connectors in the product name

The number before the hyphen in the product name indicates the number of electrical connectors. The number following the hyphen indicates the number of optical connectors of the device. For example, the switch X212-2 has twelve electrical and two optical connectors.

## 3.2 Product overview

### Article numbers

You can find the article numbers of the devices in the section "Introduction (Page 3)".

### Unpacking, checking

#### **WARNING**

Do not use any parts that show evidence of damage. If you use damaged parts, there is no guarantee that the device will function according to the specification.

If you use damaged parts, this can lead to the following problems:

- Injury to persons
- Loss of the approvals
- Violation of the EMC regulations

Use only undamaged parts.

1. Make sure that the package is complete.
2. Check all the parts for transport damage.

If the consignment is incomplete or damaged, contact your supplier or your local Siemens office.

### Components of the product

The following parts ship with a SCALANCE X-200 IE switch:

- One device
- One 2-pin plug-in terminal block (signaling contact)
- One 4-pin plug-in terminal block (power supply)
- One DVD (configuration manual, operating instructions, Primary Setup Tool, SNMP OPC profiles)

The following components are supplied with a SCALANCE X-200 IE switch with the **PRO** supplement:

- One device
- Protective caps for the data interfaces
- Protective caps for the connectors of the power supply
- One protective cap for the signaling contact
- One DVD (configuration manual, operating instructions, Primary Setup Tool, SNMP OPC profiles)

The following parts ship with a SCALANCE XF-200IRT IE switch with slots for **bus adapters**:

- One device
- One 2-pin plug-in terminal block (signaling contact)
- Two 2-pin plug-in terminal blocks (power supply)
- One DVD (configuration manual, operating instructions, Primary Setup Tool, SNMP OPC profiles)
- In addition with the premounted variant SCALANCE XF202-2P IRT:
  - 2 bus adapters BA SCRJ/RJ-45
- In addition with the premounted variant SCALANCE XF201-3P IRT:
  - 1 bus adapter BA 2xSCRJ
  - 1 bus adapter BA SCRJ/RJ-45

### 3.3 Device views

#### Device view based on the example of an X204-2TS

The following figure describes the individual components of an IE switch X200.

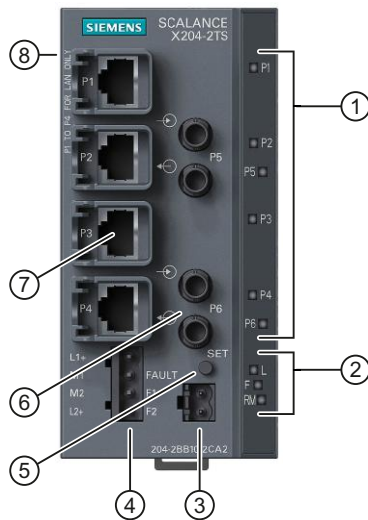

- 1 LEDs for attachments to Industrial Ethernet
- 2 LEDs
  - L: Power LED, power supply
  - F: Fault LED
  - RM: Redundancy manager or standby
- 3 Connector for signaling contact
- 4 Connector for power supply
- 5 SET button
- 6 Optical attachment to Industrial Ethernet
- 7 Electrical attachment to Industrial Ethernet
- 8 (on rear of device, not shown in figure:) Slot for C-PLUG

#### Device view based on the example of an X202-2P IRT PRO

The following figure describes the individual components of a PRO version of an IE switch X-200.

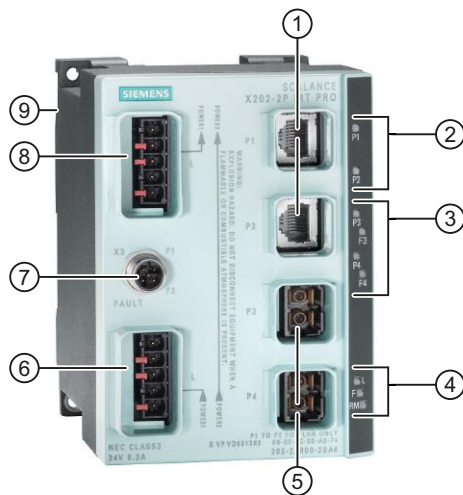

- 1 Electrical attachments to Industrial Ethernet
- 2 LEDs for electrical connectors
- 3 LEDs for optical connectors with diagnostics LEDs
- 4 LEDs
  - L: Power LED, power supply
  - F: Fault LED
  - RM:
    - green = redundancy manager
    - yellow = standby indicator
- 5 Optical attachments to Industrial Ethernet
- 6 Connector for the power supply (supplied with L1, additionally looped through to L2)
- 7 Connector for signaling contact
- 8 Power supply for further devices (looped through from L1 to L2)
- 9 (on rear of device, not shown in figure): Slot for the C-PLUG and SET button

### Device view based on the example of an XF204

The following figure describes the individual components of an IE switch X-200, flat design.

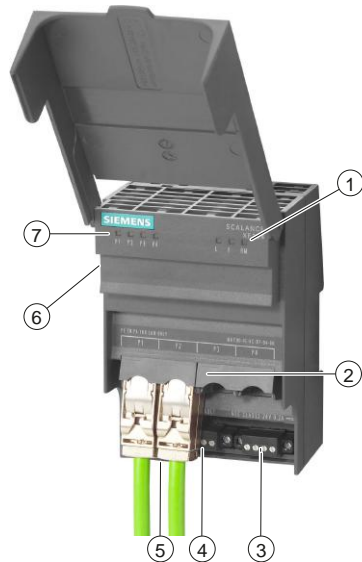

- 1 LEDs
  - L: Power LED, power supply
  - F: Fault LED
  - RM: Redundancy manager
- 2 Attachments to Industrial Ethernet
- 3 Connector for power supply
- 4 Connector for signaling contact
- 5 (behind the connectors, not shown in figure:) SET button
- 6 (on side of device, not shown in figure:) Slot for C-PLUG
- 7 LEDs for attachments to Industrial Ethernet

### Device view based on the example of an XF204-2BA IRT

The following figure describes the individual components of an IE switch XF-200IRT, flat design.

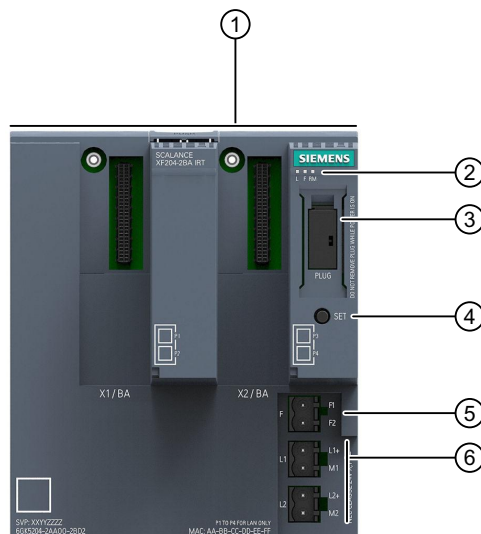

- 1 BaseUnit with slots for 2 bus adapters  
The BaseUnit provides the electrical and mechanical connection of the bus adapters.
- 2 LEDs
  - L: Power LED, power supply
  - F: Fault LED
  - RM: Redundancy manager
- 3 Slot for C-PLUG
- 4 SET button
- 5 Connector for signaling contact
- 6 Connector for power supply

## 3.4 Accessories

### C-PLUG

Component	Description	Article number
C-PLUG	Configuratiioon plug, exchangeable storage medium for configuration data	6GK1 900-0AB00

### Power limiter

Component	Description	Article number
Redundancy module SITOP PSE202U NEC Class 2	Extension module for limiting the output power according to NEC Class 2 (power limiter)	6EP1 962-2BA00

### Plug Power Plug PRO

Component	Description	Article number
Power Plug PRO	5-pin push-pull-connector for installation on site 1 connector per package	6GK1 907-0AB10-6AA0

### RJ-45 data plug-in connector

Component	Description	Article number
IE FC RJ-45 PLUG PRO (push pull)	RJ-45 data plug-in connector for IE FC TP cables 2x2, IP65 1 connector per package	6GK1 901-1BB20-6AA0
IE RJ-45 PLUG PRO (push pull)	RJ-45 data plug-in connector for IE TP cables 2x2, IP65 1 connector per package	6GK1 901-1BB10-6AA0
IE FC RJ-45 PLUG 180 2x2	RJ-45 data plug-in connector for IE FC cables 2x2, 180° cable outlet 10/100 Mbps, rugged metal housing, 1 connector per package	6GK1 901-1BB10-2AA0
IE FC RJ-45 PLUG 180 2x2	RJ-45 data plug-in connector for IE FC cables 2x2, 180° cable outlet, 10/100 Mbps, rugged metal housing 10 connectors per package	6GK1 901-1BB10-2AB0
IE FC RJ-45 PLUG 180 2x2	RJ-45 data plug-in connector for IE FC cables 2x2, 180° cable outlet, 10/100 Mbps, rugged metal housing 50 connectors per package	6GK1 901-1BB10-2AE0
IE FC RJ-45 PLUG 180 4x2	RJ-45 data plug-in connector for IE FC cables 4x2 (24 AWG), 180° cable outlet, CAT6A, 10/100/1000/10000 Mbps, rugged metal housing 1 connector per package	6GK1 901-1BB12-2AA0



Component	Description	Article number
IE FC RJ-45 PLUG 180 4x2	RJ-45 data plug-in connector for IE FC cables 4x2 (24 AWG), 180° cable outlet, CAT6A, 10/100/1000/10000 Mbps, rugged metal housing 10 connectors per package	6GK1 901-1BB12-2AB0
IE FC RJ-45 PLUG 180 4x2	RJ-45 data plug-in connector for IE FC cables 4x2 (24 AWG), 180° cable outlet, CAT6A, 10/100/1000/10000 Mbps, rugged metal housing 50 connectors per package	6GK1 901-1BB12-2AE0

### SC RJ plug-in connector

Component	Description	Article number
IE SC RJ POF PLUG PRO (push pull)	SC RJ plug-in connector for POF fiber-optic cables 1 duplex connector per package	6GK1 900-0MB00-6AA0
IE SC RJ PCF PLUG PRO (push pull)	SC RJ plug-in connector for PCF fiber-optic cables 1 duplex connector per package	6GK1 900-0NB00-6AA0

### Bus adapter

The bus adapters allow you a free choice of the connector technology for SCALANCE XF204-2BA IRT.

SCALANCE XF204-2BA IRTs support the following bus adapters:

Component	Description	Article number
BA 2×RJ45 *)	PROFINET bus adapter with Ethernet socket for standard RJ-45 plugs	6ES7 193-6AR00-0AA0
BA 2×RJ45 (Coated) *)	PROFINET bus adapter with Ethernet socket for standard RJ-45 plugs, with printed circuit boards with conformal coating.	6AG1 193-6AR00-7AA0
BA 2×FC *)	PROFINET bus adapter with FastConnect Ethernet connector for direct connection of the bus cable)	6ES7 193-6AF00-0AA0
BA 2×FC (Coated) *)	PROFINET bus adapter with FastConnect Ethernet connector for direct connection of the bus cable with printed circuit boards with conformal coating.	6AG1 193-6AF00-7AA0
BA 2xSCRJ	PROFINET bus adapter with fiber-optic connector POF/PCF	6ES7 193-6AP00-0AA0
BA 2xSCRJ (Coated)	PROFINET bus adapter with FO connector POF/PCF with printed circuit boards with conformal coating.	6AG1 193-6AP00-2AA0
BA SCRJ/RJ45	Media converter, PROFINET bus adapter with fiber-optic connector POF/PCF ↔ standard RJ-45 plug	6ES7 193-6AP20-0AA0
BA SCRJ/FC	Media converter (PROFINET bus adapter with fiber-optic connector POF/PCF ↔ direct connection of the bus cable	6ES7 193-6AP40-0AA0

\*) The approvals for shipbuilding are only valid with the indicated bus adapters.

3.4 Accessories

**Note**

If you wish to operate a SCALANCE XF204-2BA IRT with just one BusAdapter, insert the BusAdapter in the left-hand slot, ports P1 and P2.

If only one BusAdapter is plugged in the right-hand slot (ports P3 and P4), communication via all ports of the SCALANCE XF204-2BA IRT is blocked.

**Note**

**Note approvals of the bus adapters**

Bus adapters do not always have the same approvals as the basic devices. If you operate a basic device with a bus adapter that does not meet the conditions of an approval, this approval no longer applies to the basic device.

The bus adapter BA 2xSCRJ (coated), for example has no FM approval. If you operate the basic device with a BA 2xSCRJ (coated) the FM approval of the basic device lapses.

**Accessories for devices with bus adapter slots**

**Reference identification plates**

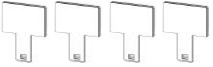
Component	Description	Article number	Figure
Reference identification plates	<p>The reference identification plates (according to EN 81346) can be plugged into every bus adapter, see Manual Collection "Distributed IO system ET 200SP", reference in the section "Introduction (Page 3)" section "Further documentation".</p> <p>The plates allow reference identification of the ET 200SP components.</p> <p>They can be ordered on a mat for thermotransfer and ink jet printers.</p> <p>Due to the standard plotter frame, the reference identification plate is suitable for labeling with ECAD systems.</p> <p>Mat with 16 plates Pack of 10</p>	6ES7 193-6LF30-0AW0	
Cover for the bus adapter slots	<p>Cover for the unused bus adapter slots</p> <p>With the cover the plug contacts are protected from contamination.</p> <p>Pack of 5</p>	6ES7 591-3AA00-0AA0	-

## 3.5 The LEDs

### 3.5.1 LED display when the device starts up

When the X-200 starts up, the LEDs light up in the following sequence:

- The green power LED lights up immediately after turning on the device.
- The LEDs of the Ethernet connectors light up for approximately 6 seconds.
- When the Ethernet LEDs go off, the red fault LED is lit for approximately 20 seconds.
- Following this, after approximately 2 seconds the correct link status is displayed.

The X-200 is now ready for operation.

### 3.5.2 Power LED "L" (green/yellow LED)

The power LED shows the status of the power supply on the X-200 IE switch. The power LED can light up either green or yellow. The meanings of the display are as follows:

LED color	LED status	Meaning
Green	Lit	Both power supplies are connected; in other words, redundant power supply.
Yellow	Lit	Only one power supply is connected or the voltage is < 14 VDC at one of the two connectors.
-	Off	No power supply is connected or the voltage is < 14 VDC or with TS devices < 8 VDC.

#### Note

The following devices do not have a redundant power supply:

- X201-3P IRT PRO
- X202-2P IRT PRO
- X204IRT PRO

### 3.5.3 Fault LED "F" (yellow/red LED)

The fault LED indicates a fault/error on the X-200. If the X-200 detects an error, the signaling contact is opened at the same time assuming that the response of the signaling contact was not configured differently.

3.5 The LEDs

The meanings of the fault LED display are as follows:

LED color	LED status	Meaning
Yellow	Lit	The LED can only adopt this status with FM devices. Check the received power or the loss of power on optical connections. If necessary, replace the parts.
Red	Lit	The fault LED lighting up can have the following meanings: <ul style="list-style-type: none"> <li>• Link down event on a monitored port</li> <li>• Loss of the power supply</li> <li>• C-PLUG error</li> <li>• Device is in PROFINET mode:                             <ul style="list-style-type: none"> <li>– There is no connection to the controller.</li> <li>– There is a connection to the controller. A configured diagnostics interrupt is also pending, for example power fail interrupt, C-PLUG interrupt etc.</li> </ul> </li> <li>• Redundancy manager connected through</li> <li>• Switchover of standby connection</li> <li>• A defined value was undershot in a monitored optical connection.</li> <li>• A loop was detected.</li> <li>• Device startup. The LED lights up for approximately 20 seconds.</li> </ul>
Red	Flashing	Internal error detected. Notify maintenance personnel. If necessary, send the device in for repair.
-	Off	No error detected.

3.5.4 Redundancy manager LED "RM" (green LED)

The green LED shows the following statuses of the X-200:

LED color	LED status	Meaning
Green	Lit	The device is operating in the role of redundancy manager. The ring is operating free of errors. The monitoring is enabled.
Green	Flashing	The device is operating in the role of redundancy manager. An interruption was detected in the ring. The device has switched through.
-	Off	The device is not operating in the role of redundancy manager.

**Note**

This LED labeled on the device with "RM" has a dual function. The color of the display changes depending on the function:

- If the LED is lit green, the redundancy manager function is indicated.
- If the LED is lit yellow, the standby function is indicated.

In Web Based Management (WBM), the LED is labeled differently depending on the function:

- The redundancy manager function (as shipped) is labeled "RM".
- The standby function is labeled "SB" in the WBM.

### 3.5.5 Standby LED "RM" (yellow LED)

You will find the standby LED only on devices with the IRT function.

---

#### Note

This LED labeled on the device with "RM" has a dual function. The color of the display changes depending on the function:

- If the LED is lit green, the redundancy manager function is indicated.
- If the LED is lit yellow, the standby function is indicated.

In Web Based Management (WBM), the LED is labeled differently depending on the function:

- The redundancy manager function (as shipped) is labeled "RM".
  - The standby function is labeled "SB" in the WBM.
- 

The yellow LED indicates the following statuses of the X-200IRT:

LED color	LED status	Meaning
Yellow	Lit	The standby function is activated, the switch is in active mode.
Yellow	Flashes slowly	The standby function is activated, the switch is in passive mode.
Yellow	Flashes quickly	Standby partner lost.
-	Off	The standby function is not activated.

### 3.5.6 Port LEDs "P" (green/yellow LEDs)

The LEDs of the Ethernet connectors can be lit green or yellow. The meanings of the display are as follows:

LED color	LED status	Meaning
Green	Lit	Link exists, no data reception
Yellow	Lit	Link exists, data being received Device startup. The LED lights up for approximately 6 seconds.
Yellow	Flashing	Setting or display of the fault mask

The following statuses of the port LEDs do not exist on devices with the IRT function:

LED color	LED status	Meaning
Green	flashes once per period	Link exists and port in "blocking" status. In this status, the port only receives management data (no user data).
Green	flashes three times per period	Link exists and port is deactivated by the management. In this status, no data is sent or received via the port.
Green	flashes four times per period	Port exists and is in the "monitor port" status. In this status, the data traffic of another port is mirrored to this port.

### 3.5 The LEDs

#### 3.5.7 Diagnostics LEDs for optical connectors "F" (yellow LED)

You will find the diagnostics LEDs only on the devices with the IRT function. With the SCALANCE XF204-2BA IRT you will only find the diagnostics LEDs on bus adapters with SCRJ ports.

The status of the optical connectors is indicated by an additional yellow LED per connector. The LEDs signal the following statuses:

LED color	LED status	Meaning
Yellow	Lit	Check the plug-in connection and the quality of the fiber-optic cable. If necessary, replace the parts.
-	Off	Relevant only if the link exists. The existing link power margin is adequate for error-free operation.

#### 3.5.8 Show Location

##### Localizing an IE Switches X-200

To identify an IE Switch X-200 locally and with certainty, you can use the "show location" function on a programming device to select the node over the network and make it flash. This can be used, for example, when assigning addresses to make sure that the correct node receives the address. All port LEDs of the addressed node flash green at 2 Hz.

With the Primary Setup Tool (PST) V3.0 or higher, you can trigger this function with "Module \ Flash".

## 3.6 The SET button

### Function of the SET button

With the SET button, you can change various settings of the device. The changed settings remain after cycling power to the device.

Different settings are made depending on how long you hold down the SET button, as described in the following table:

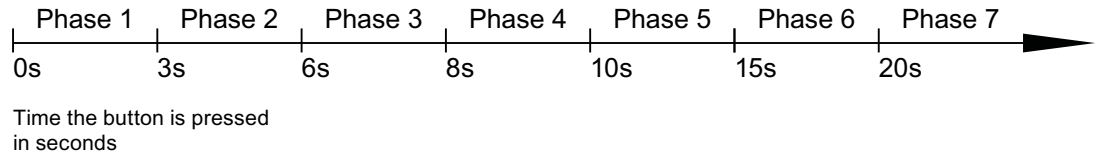

Figure 3-1 Phases for changing settings using the SET button

Phase	Description
1	The currently set fault mask is displayed. If no fault mask has been set, all ports flash one after the other. If you release the button in phase 1, this has no effect.
2	The LEDs of the ports at which there is currently a link flash at 2.5 Hz. If you release the button in phase 2, this has no effect.
3	The LEDs of the ports at which there is currently a link and the LEDs of the connected power supply are lit permanently. If you release the button in phase 3, the fault mask corresponding to the lit LEDs is adopted.
4	The RM LED flashes. If you release the button in phase 4, the redundancy manager is deactivated. The redundancy function remains enabled. The device changes to "Automatic Redundancy Detect" mode.
5	The RM LED is lit permanently. If you release the button in phase 5, the redundancy function is activated and the device is configured as HRP manager.
6	The LEDs of the ring ports flash and the RM LED is off. If you release the button in phase 6, the redundancy function is disabled.
7	All LEDs flash. The device is reset to factory settings.

### 3.7 The C-PLUG

#### Area of application

The C-PLUG is an exchangeable medium for storage of the configuration and project engineering data of the basic device. This means that the configuration data remains available if the basic device is replaced.

#### How it works

Power is supplied by the basic device. The C-PLUG retains all data permanently when the power is turned off.

If an empty C-PLUG (factory settings) is inserted, all configuration data of an IE Switch X-200 is saved to it when the device starts up. Changes to the configuration during operation are also saved on the C-PLUG without any operator intervention being necessary.

If a C-PLUG is inserted, the configuration stored internally on the basic device is no longer changed. All changes made to the configuration during ongoing operation are only stored on the C-PLUG.

A basic device with an inserted C-PLUG automatically uses the configuration data of the C-PLUG when it starts up. This is, however, only possible when the data was written by a compatible device type.

This allows fast and simple replacement of the basic device. If a device is replaced, the C-PLUG is taken from the failed component and inserted in the replacement device. The first time it is started up, the replacement device has the same configuration as the failed device except for the MAC address set by the vendor.

#### Compatible devices

As a general rule, the data on the C-PLUG is only compatible with devices having an identical order number and the same device name.

The device combinations shown in the following table are exceptions. With these devices, the exchange of the C-PLUG is possible in one direction.

Device type	C-PLUG created by device with order number		Compatible with device with order number
X204-2	6GK5 204-2BB00-2AA3	➔	6GK5 204-2BB10-2AA3
X204-2LD	6GK5 204-2BC00-2AA3		6GK5 204-2BC10-2AA3
X206-1	6GK5 206-1BB00-2AA3		6GK5 206-1BB10-2AA3
X206-1LD	6GK5 206-1BC00-2AA3		6GK5 206-1BC10-2AA3
X208	6GK5 208-0BA00-2AA3		6GK5 208-0BA10-2AA3
X208PRO	6GK5 208-0HA00-2AA6		6GK5 208-0HA10-2AA6

#### Note

Combinations other than those shown in the table are not compatible with each other.



**Note**

If you insert a C-PLUG in a compatible device, the system name of the original device is entered both in the system name as well as in the PROFINET IO device name of the compatible device.

---

**Using a previously written C-PLUG**

If you want to insert a C-PLUG that has already been used and written to into a new differently configured X-200 IE switch, you will first need to delete the existing data on the C-PLUG. You will find information about this in the configuration manual of the SCALANCE X-200 in the section on the WBM menu items.

---

**Note**

The X-200 IE switches normally start up with the configuration of the C-PLUG, assuming this was written to by a compatible device type. If the C-PLUG was written to by an incompatible device type, the basic device will not start up fully and signals an error. The WBM menu "System C-PLUG" is displayed automatically. Here, use the "Modify C-PLUG" function to specify whether or not the device operates with a C-PLUG.

If you operate a device with a C-PLUG, the C-PLUG can either be initialized with the factory settings or with the settings stored internally on the device.

---

**Diagnostics**

The following events are signaled by the diagnostics mechanisms of the X-200, such as LEDs, WBM etc.:

- Inserting a C-PLUG that contains the configuration of an incompatible device type.
- The accidental removal of a C-PLUG
- General malfunctions of the C-PLUG.

**The C-PLUG does not ship with the product**

The C-PLUG is not supplied with the IE switches X-200, see section "Accessories (Page 24)".

**Inserting in the slot****NOTICE**

- **Insert and remove the C-PLUG only when power is off.**
- **In a device with a varnished printed circuit board, you may only use a C-PLUG with a varnished board.**

3.7 The C-PLUG



Figure 3-2 C-PLUG and slot based on the example of an X-200

You will find information regarding the location of the C-PLUG slot for the various product groups in the "Device views (Page 22)".

Follow the steps below to insert the C-PLUG:

1. Remove the screw cover.
2. Insert the C-PLUG in the slot.
3. Close the slot with the screw cover.

### Removing the C-PLUG

It is only necessary to remove the C-PLUG if the IE Switch X-200 develops a fault.

You can lever the C-PLUG out of the slot carefully using flat pliers, tweezers, or a small screwdriver.

If no C-PLUG is inserted in the device, when the device restarts, an error message is output in Web Based Management and in the Command Line Interface. In this case, you will need to set the device to operation without C-PLUG. For further information, refer to the section "System C-PLUG" in the section on the WBM menu in the configuration manual.

## 3.8 Starting the device for the first time

---

### **Note**

When the device is started up for the first time, the power-up time is approximately 1 minute longer than for all other starts of the device. The reason for this delay is the calculation of the certificates required for encrypted communication. With SCALANCE devices, encrypted access is possible via Web Based Management with HTTPS or via the Command Line Interface with SSH.

---

*3.8 Starting the device for the first time*

# Installation

## 4.1 Safety notices for installation

### Safety notices

When installing the device, keep to the notices listed below.

 **WARNING**

**When used in ships, a DIN rail does provide adequate support**

For the following devices, installation on a 35 mm DIN rail for use in ships is not permitted:

- X201-3P IRT PRO
- X202-2P IRT PRO
- X204IRT PRO
- X208PRO
- X212-2
- X212-2LD
- X216
- X224

In ships, the DIN rail does not provide adequate support.

 **WARNING**

If a device is operated in an ambient temperature of more than 50 °C, the temperature of the device housing may be higher than 70 °C. The device must therefore be installed so that it is only accessible to service personnel or users that are aware of the reason for restricted access and the required safety measures at an ambient temperature higher than 50 °C.

 **WARNING**

If the device is installed in a cabinet, the inner temperature of the cabinet corresponds to the ambient temperature of the device.

### Safety notices on use in hazardous areas

#### General safety notices relating to protection against explosion

 <b>WARNING</b>
<b>EXPLOSION HAZARD</b>
Replacing components may impair suitability for Class 1, Division 2 or Zone 2.

 <b>WARNING</b>
The device is intended for indoor use only.

 <b>WARNING</b>
The device may only be operated in an environment with pollution degree 1 or 2 (see IEC 60664-1).

 <b>WARNING</b>
When used in hazardous environments corresponding to Class I, Division 2 or Class I, Zone 2, the device must be installed in a cabinet or a suitable enclosure.

#### Safety notices for use according to ATEX and IECEx

If you use the device under ATEX or IECEx conditions you must also keep to the following safety notices in addition to the general safety notices for protection against explosion:

 <b>WARNING</b>
The equipment shall only be used in an area of not more than pollution degree 2, as defined in EN/IEC 60664-1.

 <b>WARNING</b>
<b>Requirements for the cabinet/enclosure</b>
The equipment shall be installed in a suitable enclosure that provides a degree of protection not less than IP54 in accordance with EN/IEC 60079-15.

#### Devices with approval [op is Gb] for optical interfaces

Some devices have an additional ATEX approval according to II 3 (2) G Ex nA [op is Gb] IIC T4 Gc and an additional approval in compliance with IECEx according to Ex nA [op is Gb] IIC T4 Gc, see section "Approvals (Page 81)". This is indicated on the type plate. With these devices the FO bus connections may run through or in a Zone 1 hazardous area.

**⚠ WARNING****Cable**

If the cable or conduit entry point exceeds 70 °C or the branching point of conductors exceeds 80 °C, special precautions must be taken. If the equipment is operated in an air ambient in excess of 50 °C, only use cables with admitted maximum operating temperature of at least 80 °C.

**Safety notices when using according to FM**

If you use the device under FM conditions you must also keep to the following safety notices in addition to the general safety notices for protection against explosion:

**⚠ WARNING****EXPLOSION HAZARD**

For operation the device is intended to be installed within an enclosure/control cabinet. The inner temperature of the enclosure/control cabinet corresponds to the ambient temperature of the device. Use installation wiring connections with admitted maximum operating temperature of at least 30 °C higher than maximum ambient temperature.

**⚠ WARNING**

Wall mounting outside of the control cabinet or housing does not fulfill the requirements of the FM approval.

**⚠ WARNING**

Wall mounting is only permitted if the requirements for the housing, the installation regulations, the clearance and separating regulations for the control cabinets or housings are adhered to. The control cabinet cover or housing must be secured so that it can only be opened with a tool. An appropriate strain-relief assembly for the cable must be used.

**Note**

You must not install the device on a wall in hazardous areas.

**Safety notices when using the device as industrial control equipment according to UL 61010-2-201**

If you use the device under UL 61010-2-201 conditions you must also keep to the following safety notices in addition to the general safety notices for protection against explosion:

 <b>WARNING</b>
<p>The devices are "open equipment" acc. to the standard UL 61010-2-201. To fulfill requirements for safe operation with regard to mechanical stability, flame retardation, stability, and protection against contact, the following alternative types of installation are specified:</p> <ul style="list-style-type: none"><li>• Installation in a suitable cabinet.</li><li>• Installation in a suitable enclosure.</li><li>• Installation in a suitably equipped, enclosed control room.</li></ul>

**Further notes**

<b>NOTICE</b>
<p><b>Warming and premature aging of the IE switch due to direct sunlight</b></p> <p>Direct sunlight can heat up the device and can lead to premature aging of the IE switch and its cabling.</p> <p>Provide suitable shade to protect the IE switch against direct sunlight.</p>

---

**Note**

**Note the mounting position for XF and TS devices**

With the following IE switches, an ambient temperature of maximum +40 °C is permitted if the device is installed on a vertical rail:

- X204-2TS
- X204-2LD TS
- XF204
- XF204-2
- XF206-1
- XF208
- XF204IRT

---



## 4.2 Installation options

### **Types of installation**

IE Switches X-200 can be installed in the following ways:

- Installation on a 35 mm DIN rail complying with DIN EN 60715
- Installation on a SIMATIC S7-300 standard rail
- Wall mounting

Unless stated otherwise, the mounting options listed below apply to all X-200 IE switches.

### **Exception XF-200**

The XF devices (flat design) can only be installed on a 35 mm DIN rail.

### **Installation clearance**

Keep to the following minimum clearances so that the convection ventilation of the device is not blocked:

- Below at least 10 cm
- Above at least 10 cm

## 4.3 Installation on a DIN rail

### Installation

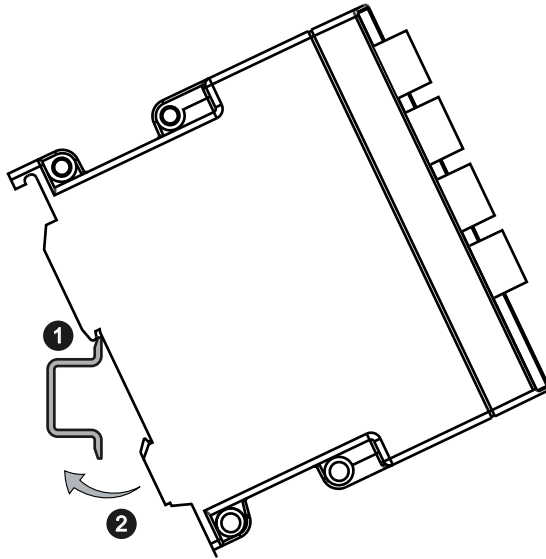

Figure 4-1 Installation on a 35 mm DIN rail

To install an X-200 on a 35 mm DIN rail complying with DIN EN 60715, follow the steps below:

1. Fit the middle locking mechanism of the device on to the DIN rail.
2. Press the device down against the DIN rail until it locks into place.
3. Fit the connectors for the power supply.
4. Fit the connectors for the signaling contact
5. Insert the terminal blocks or M12 cable connectors into the sockets on the device.

### Removal

To remove an X-200 from a DIN rail, follow the steps below:

1. First disconnect all connected cables.
2. Use a screwdriver to release the lower DIN rail catch of the device and pull the lower part of the device away from the rail.

## 4.4 Mounting onto standard rail (SCALANCE XF204-2BA IRT)

### Installation

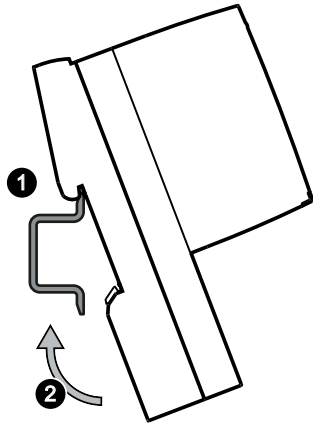

Figure 4-2 DIN rail mounting

To install the device on a 35 mm DIN rail complying with DIN EN 60715, follow the steps below:

1. Place the housing guide of the device on the top edge of the DIN rail ①.
2. Press the device down against the DIN rail until the spring catch locks in place ②.
3. Fit the connectors for the power supply, see the section "Connecting up (Page 49)".
4. Insert the terminal blocks into the sockets on the device.

### Removal

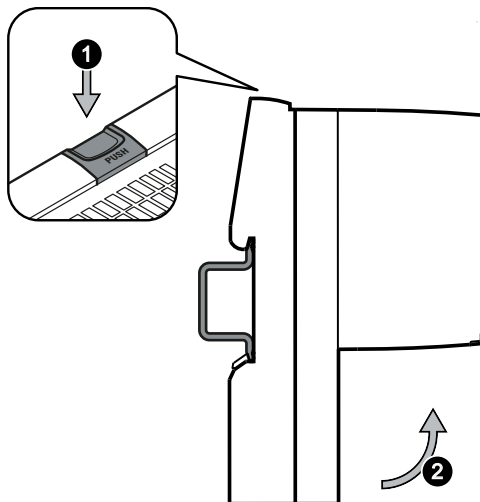

Figure 4-3 Removing from a DIN rail

*4.4 Mounting onto standard rail (SCALANCE XF204-2BA IRT)*

To remove the device from a DIN rail, follow the steps below:

1. Disconnect all connected cables.
2. Release the DIN rail locking mechanism by pressing down on the release button ①.
3. Pull the lower part of the device away from the DIN rail ②.

## 4.5 Installation on a standard rail

### Installation on a SIMATIC S7-300 standard rail

To install an X-200 on a standard rail, follow the steps below:

1. Fit the housing guide on the top of the housing into the standard rail.
2. Screw the X-200 to the underside of the standard rail.
3. Fit the connectors for the power supply.
4. Fit the connectors for the signaling contact.
5. Insert the terminal blocks or M12 cable connectors into the sockets on the X-200.

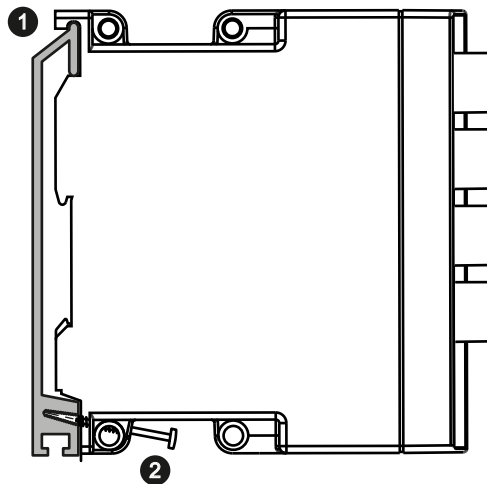

Figure 4-4 Installation on a SIMATIC S7-300 standard rail

### Removal

To remove an X-200 from a standard rail, follow the steps below:

1. First disconnect all connected cables.
2. Release the screws on the bottom of the standard rail.
3. Remove the X-200 from the standard rail.

## 4.6 Wall mounting

### Wall mounting

---

#### Note

The wall mounting must be capable of supporting at least four times the weight of the X-200, see section Technical specifications (Page 69).

---

When mounting on a wall, use mounting fittings suitable for the type of wall. To secure the device in concrete, you could, for example use the following material:

- 4 wall plugs, 6 mm in diameter and 30 mm long
- 4 screws 3.5 mm in diameter and 40 mm long

Follow the steps below to install the X-200 on a wall:

1. Prepare the drill holes for wall mounting.  
You will find the precise dimensions in the Appendix Dimension drawings (Page 91).
2. Connect the electrical cable connecting cables.
3. Fit the connectors for the signaling contact.
4. Insert the terminal blocks or M12 cable connectors into the sockets on the IE Switch X-200.
5. Screw the device to the wall.

## 4.7 Mounting bus adapters

### NOTICE

#### Cover unused bus adapter slots

If you do not cover unused bus adapter slots, this can lead to the following problems:

- Loss of the approvals
- Violation of the EMC regulations
- Failure of the data traffic

Close unused bus adapter slots with the supplied covers.

Remove the covers only immediately before you mount the bus adapter.

### Required tool:

- Slotted screwdriver, blade width 3 to 3.5 mm
- or
- Torx screwdriver, size T10

### Installation

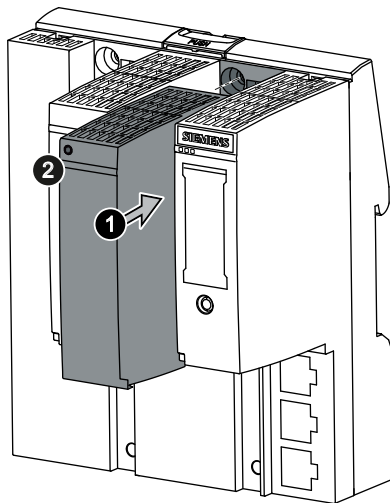

Figure 4-5 Mounting bus adapters

To fit a bus adapter, follow the steps below:

1. Turn off the power to the device.
2. Remove the cover of the bus adapter slot.
3. If necessary mount a strain relief, see section "AUTOHOTSPOT".
4. Plug the bus adapter parallel into the BaseUnit until it can be heard to lock in place ①.

*4.7 Mounting bus adapters*

5. Screw the bus adapter to the BaseUnit of the device with the supplied screw (tightening torque 0.2 Nm) ②.  
Use the specified tool for this.
6. Insert the connection plugs into the sockets intended for this on the bus adapter.

**Removal**

To remove a bus adapter, follow the steps below:

1. Turn off the power to the device.
2. Remove all connected cables from the BusAdapter.
3. Loosen the screw connection of the bus adapter.
4. Pull the bus adapter out of the Base Unit to the front.
5. If necessary remove the strain relief, see section "AUTOHOTSPOT".
6. Close the bus adapter slot with a cover.



## Connecting up

### 5.1 Safety when connecting up

#### Safety notices

When connecting up the device, keep to the safety notices listed below.

 **WARNING**

The equipment is designed for operation with Safety Extra-Low Voltage (SELV) by a Limited Power Source (LPS).

This means that only SELV / LPS complying with IEC 60950-1 / EN 60950-1 / VDE 0805-1 must be connected to the power supply terminals, or the power supply unit for the equipment power supply must comply with NEC Class 2, as described by the National Electrical Code (r) (ANSI / NFPA 70).

If the equipment is connected to a redundant power supply (two separate power supplies), both must meet these requirements.

---

**Note**

**Limitation of the output voltage according to NEC Class 2 by redundancy module**

To meet the requirements according to NEC Class 2, you can use a power supply with SELV along with a power limiter, see e.g. the section "Accessories (Page 24)".

---

**Note**

**Safety extra-low voltage**

The supply of the devices by PELV (Protective Extra Low Voltage) according to DIN VDE 0100-410 or IEC 60364-4-41 is permitted when the generated nominal voltage does not exceed the voltage limits 25 VAC or 60 VDC.

---

### Safety notices on use in hazardous areas

#### General safety notices relating to protection against explosion

 <b>WARNING</b>
<b>EXPLOSION HAZARD</b>
Do not connect or disconnect cables to or from the device when a flammable or combustible atmosphere is present.

#### Exceptions

For the devices listed below, there are no requirements according to NEC Class 2 or LPS. For these devices, note the conditions described in the section Supply for IRT-PRO devices (Page 54).

- X201-3P IRT PRO
- X202-2P IRT PRO
- X204IRT PRO

#### Safety notices when using the device according to Hazardous Locations (HazLoc)

If you use the device under HazLoc conditions you must also keep to the following safety notices in addition to the general safety notices for protection against explosion:

 <b>WARNING</b>
<b>EXPLOSION HAZARD</b>
You may only connect or disconnect cables carrying electricity when the power supply is switched off or when the device is in an area without inflammable gas concentrations.

#### Safety notices for use according to ATEX and IECEx

If you use the device under ATEX or IECEx conditions you must also keep to the following safety notices in addition to the general safety notices for protection against explosion:

 <b>WARNING</b>
Take measures to prevent transient voltage surges of more than 40% of the rated voltage. This is the case if you only operate devices with SELV (safety extra-low voltage).

 <b>WARNING</b>
Provisions shall be made to prevent the rated voltage from being exceeded by transient disturbances of more than 119 V.

## Further notes

 **WARNING****Safety notice for connecting with a LAN ID (Local Area Network)**

A LAN or LAN segment with all the interconnected devices should be contained completely in a single low voltage power distribution in a building. The LAN is designed either for "Environment A" according to IEEE802.3 or "Environment 0" according to IEC TR 62102.

Do not connect any electrical connectors directly to the telephone network (telephone network voltage) or a WAN (Wide Area Network).

**NOTICE****Overvoltage protection**

If IE Switches X-200 are supplied over long 24 V power supply lines or networks, measures are necessary to prevent interference by strong electromagnetic pulses on the supply lines. These can result, for example, due to lightning or switching of large inductive loads.

One of the tests used to attest the immunity of devices of the IE Switches X-200 to electromagnetic interference was the "surge immunity test" according to EN61000-4-5. This test requires overvoltage protection for the power supply lines. A suitable device is, for example, the Dehn Blitzductor BVT AVD 24 V type no. 918 422 or a comparable protective element.

Manufacturer: DEHN+SÖHNE GmbH+Co.KG, Hans-Dehn-Str.1, Postfach 1640, D-92306 Neumarkt, Germany.

## 5.2 Wiring rules

When wiring use cables with the following AWG categories or cross sections.

Wiring rules for ...		Screw/spring-loaded terminals
connectable cable cross sections for flexible cables ...	without wire end ferrule	0.25 - 2.5 mm <sup>2</sup> AWG: 24 - 13
	with wire end ferrule with plastic ferrule**	0.25 - 2.5 mm <sup>2</sup> AWG: 24 - 13
	with wire end ferrule without plastic ferrule**	0.25 - 2.5 mm <sup>2</sup> AWG: 24 - 13
	with TWIN wire end ferrule**	0.5 - 1 mm <sup>2</sup> AWG: 20 - 17
Stripped length of the cable		8 - 10 mm
Wire end ferrule according to DIN 46228 with plastic ferrule**		8 - 10 mm

\* AWG: American Wire Gauge

\*\* See note "Wire end ferrules"

### Note

#### Wire end ferrules

Use crimp shapes with smooth surfaces, such as provided by square and trapeze shaped crimp cross sections.

Crimp shapes with wave-shaped profile are unsuitable.

## 5.3 Power supply

### 5.3.1 Supply with X-200 via the terminal block

#### Power supply

The power supply is connected via a 4-pin plug-in terminal block that ships with the device.

- The power supply can be connected redundantly.
  - Both inputs are isolated.
  - No load distribution.
  - The power supply unit with the higher output voltage supplies the device alone.
- Power: 24 VDC
- Cable cross section for X-200: 2.5 mm<sup>2</sup>
- Cable cross section for XF-200: 1.5 mm<sup>2</sup>
- The power supply is connected over a high resistance with the enclosure to allow an ungrounded set up.
- The power supply is non-floating.
- The signal cables of the electrical Ethernet interfaces are floating.

The following table shows the pin assignment:

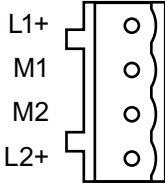
Assignment	
L1+: 24 VDC	
<b>With TS devices:</b> L1+: 12 to 24 VDC	
M1: Ground	
M2: Ground	
L2+ 24 VDC	
<b>With TS devices:</b> L2+ 12 to 24 VDC	

#### Note

##### Special features with X208PRO and the IRT-PRO devices

Note the special requirements for the power supply for the devices in the following sections.

### 5.3.2 Supply for X208PRO

#### Power supply for X208PRO

With the IE switch SCALANCE X208PRO, the power supply is connected via two 4-pin a-coded M12 sockets.

- The power supply can be connected redundantly.
  - Both inputs are isolated.
  - No load distribution.
  - The power supply unit with the higher output voltage supplies the device alone.
- Power: 24 VDC
- The power supply is connected over a high resistance with the enclosure to allow an ungrounded set up.
- The power supply is non-floating.
- The signal cables of the electrical Ethernet interfaces are floating.

The following table shows the pin assignment:

Pin no.:	Assignment
1	L1 or L2: 24 VDC
2	n. c.
3	M1 or M2
4	n. c.

### 5.3.3 Supply for IRT-PRO devices

#### Power supply for the devices of the IRT PRO version

The following descriptions of the power supply apply to the following devices:

- X201-3P IRT PRO
- X202-2P IRT PRO
- X204IRT PRO

#### Connector

##### Plastic version (standard)

The power supply is connected by default via the push-pull Power Plug PRO. This plug has a high degree of protection (IP65) and is suitable for use outside cabinets and complies with PROFINET connector technology.

The Power Plug PRO does not ship with the device, see the section “Accessories (Page 24)”:

### **Metal version**

In areas subject to the EU directives ATEX and IECEX of the National Electric Code (NEC), the Canadian Electric Code (CEC) and UL, metal connectors must be used.

Further information and technical advice on this subject is available from:  
Jürgen Hertlein, [juergen.hertlein@siemens.com](mailto:juergen.hertlein@siemens.com).

## **Power supply**

- Power: 24 VDC
- The power supply is connected over a high resistance with the enclosure to allow an ungrounded set up.
- The power supply is non-floating.
- The signal cables of the electrical Ethernet interfaces are floating.

---

### **Note**

#### **No redundant power supply**

Since the IRT PRO version of the devices does not have a redundant power supply, connect the power supply to L1 and N1.

---

### **Note**

#### **Maximum current 16 A**

The current through the Power Plug PRO must not exceed 16 A. You should therefore include a fuse that trips at a current higher than 16 A.

In areas subject to the NEC or CEC, the fuse must meet the following requirements:

- Suitable for DC (min. 60 V / max. 16 A)
- Breaking current at least 10 kA
- UL / CSA listed (UL 248-1 / CSA 22.2 No. 248.1)
- Classes R, J, L, T or CC

Otherwise the following requirements must be met:

- Suitable for DC (min. 60 V / max. 16 A)
  - Breaking current at least 10 kA
  - Approved according to IEC/EN 60127-1
  - Breaking characteristics
    - With circuit breakers: B or C
    - With fuses: slow blow
- 

## **Power supply looped through**

The devices also have a connector for the switched mode and unswitched power supply of other devices with 24 VDC. Via these interfaces (L1+, N1 and L2+, N2) it is possible to loop the power through with connector technology compliant with PROFINET.

You should also refer to the manual "SIMATIC Distributed IO System ET 200pro (<https://support.industry.siemens.com/cs/ww/en/view/21210852>)".

**Note**

**Notes on operating under marginal conditions**

When looping through the power supply, take into account the limit values; in other words, the maximum permitted current depending on the ambient temperature; refer to the table "Operation under marginal conditions" below.

When looping through the power supply under the marginal conditions described below, the device may only be operated if it is installed horizontally. Horizontal installation position means that the device is mounted, for example on a horizontal DIN or standard rail or that the labeling on the device can be read in the normal reading direction.

If no power is looped through, any installation position is permitted.

Table 5-1 Operation under marginal conditions

Environment	Max Power 1 (L1+, N1)	Max Power 2 (L2+, N2)
+40°C	16 A	16 A
+50°C	12 A	12 A
+60°C	8 A	8 A
SCALANCE X204IRT PRO only:		
+70°C	6 A	6 A

**Pin assignment of the connectors**

The following table shows the pin assignment of the two power supply connectors:

Pin no.:	Assignment
1	L1: 24 VDC
2	N1
3	L2: 24 VDC
4	N2
5	FE (Functional Earth)

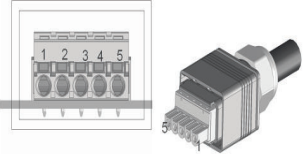

**5.3.4 Supply with XF-200IRT devices with bus adapter slots**

**Power supply for devices with bus adapter slots**

The following descriptions of the power supply apply to the following devices:

- XF204-2BA IRT



## Information on the power supply

- The power supply is connected via two 2-pin plug-in terminal blocks that ship with the device.
- The power supply can be connected redundantly.
  - Both inputs are isolated.
  - No load distribution.
  - The power supply unit with the higher output voltage supplies the device alone.
- Power: 24 VDC
- Cable cross-section: max. 2.5 mm<sup>2</sup>
- The power supply is connected over a high resistance with the enclosure to allow an ungrounded set up.
- The power supply is non-floating.
- The signal cables of the electrical Ethernet interfaces are floating.

## Position and assignment

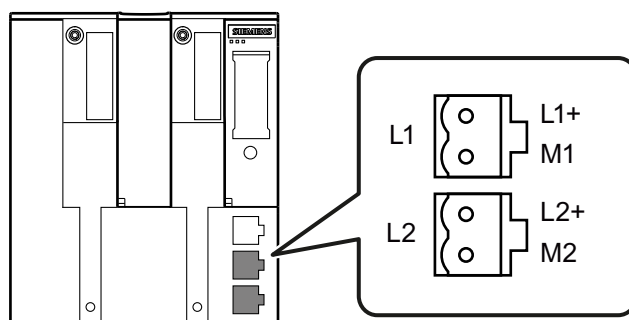

Figure 5-1 Position of the power supply and assignment of the terminal blocks

Contact	Assignment
L+	24 VDC
M	Ground

## 5.4 Grounding

### Grounding when installing on a DIN rail

The device is grounded over the DIN rail.

### Grounding when installing on an S7 standard rail

The device is grounded over its rear panel and the neck of the screw.

### Grounding with wall mounting

The device is grounded by the securing screw in the unpainted hole.

Please note that X-200 IE switches must be grounded over one securing screw with minimum resistance.

If an IE Switch X-200 is mounted on a non-conducting base, a grounding cable must be installed. The grounding cable is not supplied with the device. Connect the paint-free surface of the device to the nearest grounding point using the grounding cable.

## 5.5 Signaling contact

### Signaling contact

The signaling contact or relay contact is a floating switch with which error/fault states can be signaled by breaking the contact.

The following errors/faults can be signaled by the signaling contact:

- The loss and the establishment of a link on a monitored port.
- The failure of one of the two redundant power supplies.  
Note: Devices of the IRT PRO version do not have a redundant power supply
- The loss of the connection to the controller in PROFINET IO mode.
- The redundancy manager signals an error
- An incompatible C-PLUG was inserted.

The connection or disconnection of a communication node on an unmonitored port does not lead to an error message.

The signaling contact remains activated until the error/fault is eliminated or until the current status is applied as the new desired status using the SET button.

When the IE Switch X-200 is turned off, the signaling contact is always activated, i.e. opened.

<b>NOTICE</b>
<b>Load on the signaling contact</b>
The signaling contact can be subjected to a <b>maximum</b> load of <b>100 mA</b> (safety extra-low voltage (SELV), 24 VDC).

### Connection via 2-pin terminal block

The signaling contact is connected to a 2-pin plug-in terminal block.

The following table shows the pin assignment:

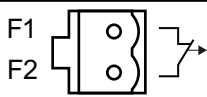
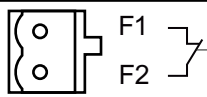
Assignment	
F1: Fault contact 1	
F2: Fault contact 2	
	SCALANCE X-200, XF-200, X-200IRT
	SCALANCE XF-200IRT

### Connection via M12 socket

With the X-200 IRT PRO devices and with the X208PRO, the connection is via a 5-pin, b-coded M12 socket.

The following table shows the pin assignment:

Pin no.:	Assignment	
1	F1	 SCALANCE X-200 IRT PRO
2	n.c.	
3	n.c.	
4	F2	
5	n.c.	

## 5.6 Attachment to Industrial Ethernet

---

### Note

#### Redundancy mechanisms

If you use redundancy mechanisms such as media redundancy "HRP" or "MRP" and/or redundant linking of rings via a standby link, remember the following:

Open the redundant path before you insert a new device or replacement device in an operating network. A bad configuration or attachment of the Ethernet cables to incorrectly configured ports causes overload in the network and a breakdown in communication.

A device may only be inserted in a network and connected in the following situations:

- HRP / MRP
  - The ring ports of the device being inserted in the ring were configured as ring ports.
  - The required redundancy mode is also enabled.
  - If the device is intended to operate as the redundancy manager, "Enable Ring Redundancy" must also be set.
- Standby link
  - Select "Enable Standby Master".
  - The "Standby Connection Name" must match the name of the partner device.
  - You must also configure the standby port.

You will find detailed information in the SCALANCE X-200 configuration manual.

---

### 5.6.1 Electrical connections

---

#### Note

##### Strain relief for the Ethernet cables

In order to avoid mechanical stress on the Ethernet cables and resulting interruption of the contact, fasten the cables at a short distance from the connector using a cable guide or busbar.

---

#### 5.6.1.1 Electrical attachments to Industrial Ethernet

##### Connection via RJ-45 jacks

The electrical connectors for Industrial Ethernet on the X-200 IE switch are designed as RJ-45 jacks with the following properties:

- MDI-X assignment
- Autonegotiation
- Auto polarity exchange

### MDI / MDI-X autocrossover function

The advantage of this function is that straight-through cables can be used throughout and external Ethernet crossover cables are unnecessary. This prevents malfunctions resulting from mismatching send and receive wires. This makes installation much easier for the user.

---

#### Note

##### Formation of loops

Please note that the direct connection of two ports on the switch or accidental connection over several switches causes an illegal loop. Such a loop can lead to network overload and network failures.

---

### Autonegotiation

Autonegotiation means the automatic detection of the functionality of the port at the opposite end. Using autonegotiation, repeaters or end devices can detect the functionality available at the port of a partner device allowing automatic configuration of different types of device. With autonegotiation, two components connected to a link segment can exchange parameters and set themselves to match the supported communication functionality.

---

#### Note

- If a port operating in autonegotiation mode is connected to a partner device that is not operating in autonegotiation mode, the partner device must be set permanently to half duplex mode.
  - If a port is set permanently to full duplex, the connected partner device must also be set to full duplex.
  - If the autonegotiation function is disabled, the MDI/MDI-X autocrossover function is also inactive. This means it may be necessary to use a crossover cable.
- 

### Auto polarity exchange

If the pair of receiving cables is incorrectly connected, in other words, RD+ and RD- are swapped over, the polarity is reversed automatically.

## Pin assignment

The following table shows the pin assignment of the RJ-45 connectors:

Pin no.:	Assignment
8	n. c.
7	n. c.
6	TD-
5	n. c.
4	n. c.
3	TD
2	RD-
1	RD+

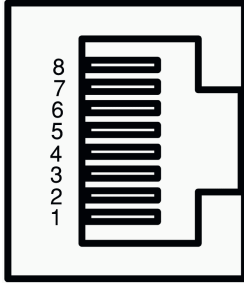

## Permitted cable lengths

- With connection using TP cords or TP-XP cords: maximum 10 m
- When connected using IE FC cable with IE RJ-45 plug:  
Depending on the cable type, a total length of up to 100 m is permitted between two devices.

### 5.6.1.2 Electrical connectors of the X208PRO

#### Connection via M12 sockets

With the IE switch SCALANCE X208PRO, the connection to Industrial Ethernet is via 4-pin, d-coded M12 sockets with MDI-X assignment.

#### MDI / MDI-X autocrossover function

The advantage of this function is that straight-through cables can be used throughout and external Ethernet crossover cables are unnecessary. This prevents malfunctions resulting from mismatching send and receive wires. This makes installation much easier for the user.

---

#### Note

##### Formation of loops

Please note that the direct connection of two ports on the switch or accidental connection over several switches causes an illegal loop. Such a loop can lead to network overload and network failures.

---

### Pin assignment

The following table shows the pin assignment of the M12 sockets:

Pin no.:	Assignment
1	RX+
2	TX+
3	RX-
4	TX-

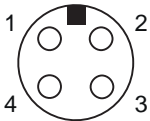

### Permitted cable lengths

- With connection using TP cords or TP-XP cords: maximum 10 m
- When connected using IE FC cable with IE RJ45 plug:  
Depending on the cable type, a total length of up to 100 m is permitted between two devices.

### IE FC M12 plug PRO

The IE FC M12 Plug PRO has a high degree of protection (IP65/67) and is suitable for connecting the X208PRO to Industrial Ethernet. You can obtain this plug using the following order number: 6GK1 901-0DB20-6AA0.

## 5.6.2 Optical attachments to Industrial Ethernet

### NOTICE

#### Failure of the data traffic due to contamination of optical plug-in connections

Optical sockets and plugs are sensitive to contamination of the end face. Contamination can lead to the failure of the optical transmission network. Take the following precautions to avoid functional impairments:

- Clean the end face of field-assembled connectors carefully before connecting. No residues of processing may remain on the connector.
- Only remove the dust caps of optical transceivers and pre-configured cables shortly before connecting the cables.
- Close unused optical sockets and plugs as well as pluggable transceivers and slots with the supplied protective caps.



### 5.6.2.1 Multimode fiber-optic cable

#### Transmission medium

The following X-200 IE switches use multimode fiber-optic cables as the transmission medium:

- X204-2
- X204-2TS
- X204-2FM
- X206-1
- X212-2
- XF204-2
- XF206-1
- X202-2IRT
- XF204-2BA IRT with corresponding bus adapter

#### Characteristics:

Transmission speed	100 Mbps
Transmission mode	100Base-FX according to IEEE 802.3
Connectors	BFOC sockets
Wavelength	1300 nm
Core diameter	50 or 62.5 $\mu\text{m}$
Outer diameter	125 $\mu\text{m}$
Light source	LED
Maximum range (segment length)	5 km

#### Note

##### No autonegotiation

With optical transmission, the full duplex mode and transmission speed cannot be changed. For this reason, the autonegotiation function cannot be selected.

### 5.6.2.2 Single mode fiber-optic cable

#### Transmission medium

The following X-200 IE switches use single mode fiber-optic cables as the transmission medium:

- X204-2LD
- X204-2LD TS

- X206-1LD
- X212-2LD

**Characteristics:**

Transmission speed	100 Mbps
Transmission mode	100Base LX
Connectors	BFOC sockets
Wavelength	1310 nm
Core diameter	9 µm
Outer diameter	125 µm
Light source	LED
Maximum range (segment length)	26 km

**Note**

**No autonegotiation**

With optical transmission, the full duplex mode and transmission speed cannot be changed. For this reason, the autonegotiation function cannot be selected.

**5.6.2.3 POF and PCF cables**

**Transmission medium**

The following X-200 IE switches use Plastic Optical Fiber (POF) or Polymer Cladded Fiber (PCF) as the transmission medium:

- X200-4P IRT
- X201-3P IRT
- X201-3P IRT PRO
- X202-2P IRT
- X202-2P IRT PRO
- XF204-2BA IRT with corresponding bus adapter

**Characteristics:**

Transmission speed	100 Mbps
Transmission mode	100Base-FX analogous to IEEE 802.3
Connectors	SC RJ jacks
Wavelength	650 nm

Core diameter	
<ul style="list-style-type: none"> <li>• with POF</li> <li>• with PCF</li> </ul>	<ul style="list-style-type: none"> <li>• 980 µm</li> <li>• 200 µm</li> </ul>
Outer diameter	
<ul style="list-style-type: none"> <li>• with POF</li> <li>• with PCF</li> </ul>	<ul style="list-style-type: none"> <li>• 1000 µm</li> <li>• 230 µm</li> </ul>
Light source	LED
Cable lengths	
<ul style="list-style-type: none"> <li>• minimum</li> <li>• maximum segment length</li> </ul>	<ul style="list-style-type: none"> <li>• 0 m</li> <li>• 50 m for POF</li> <li>• 100 m for PCF</li> </ul>
Signal attenuation	
<ul style="list-style-type: none"> <li>• with POF</li> <li>• with PCF</li> </ul>	<ul style="list-style-type: none"> <li>• 0.230 dB/m</li> <li>• 0.01 dB/m</li> </ul>

**Note****No autonegotiation**

With optical transmission, the full duplex mode and transmission speed cannot be changed. For this reason, the autonegotiation function cannot be selected.

**GI-PCF**

For segment lengths longer than 100 m, you can use GI-PCF cables. Note the information of the manufacturer.

**5.6.3 Push-pull connector for IRT-PRO devices****Push-pull connector technology**

With the following devices, the connection to Industrial Ethernet makes use of the PROFINET-compliant push-pull connector technology:

- X204IRT PRO
- X202-2P IRT PRO
- X201-3P IRT PRO

Due to their high degree of protection (IP65), the push-pull connectors are suitable for installation outside cabinets. The plugs do not ship with the product, see the section "Accessories (Page 24)".



# Technical specifications

## Construction

Type	Dimensions (W x H x D) in mm	Weight in g	Installation options - DIN rail - S7-300 standard rail - Wall mounting
X204-2	60 x 125 x 124	780	+
X204-2TS	60 x 125 x 124	780	+
X204-2FM	60 x 125 x 124	780	+
X204-2LD	60 x 125 x 124	780	+
X204-2LD TS	60 x 125 x 124	780	+
X206-1	60 x 125 x 124	780	+
X206-1LD	60 x 125 x 124	780	+
X208	60 x 125 x 124	780	+
X208PRO	90 x 125 x 124	1000	+
X212-2	120 x 125 x 124	1200	+
X212-2LD	120 x 125 x 124	1200	+
X216	120 x 125 x 124	1200	+
X224	180 x 125 x 124	1600	+
XF204	75 x 125 x 73	250	DIN rail mounting only
XF204-2	75 x 125 x 73	250	DIN rail mounting only
XF206-1	75 x 125 x 73	250	DIN rail mounting only
XF208	75 x 125 x 73	250	DIN rail mounting only
X200-4P IRT	60 x 125 x 124	780	+
X201-3P IRT	60 x 125 x 124	780	+
X201-3P IRT PRO	90 x 125 x 124	1000	+
X202-2IRT	60 x 125 x 124	780	+
X202-2P IRT	60 x 125 x 124	780	+
X202-2P IRT PRO	90 x 125 x 124	1000	+
X204IRT	60 x 125 x 124	780	+
X204IRT PRO	90 x 125 x 124	1000	+
XF204IRT	75 x 125 x 73	250	DIN rail mounting only
XF204-2BA IRT	100 x 117,1 x 74	250	DIN rail mounting only

## Ports

Type	Connectors for end devices or network components via twisted pair RJ-45 jacks with MDI X pinning 10/100 Mbps (half / full duplex) <sup>1)</sup>	Connections for end devices or network components via FO cable BFOC sockets (100 Mbps, full duplex to 100BaseFX)	Connectors for power supply 4-pin plug-in terminal block, redundant <sup>2)</sup>	Connectors for signaling contact 2-pin plug-in terminal block <sup>3)</sup>
X204-2	4	2	1	1
X204-2TS	4	2	1	1
X204-2FM	4	2	1	1
X204-2LD	4	2	1	1
X204-2LD TS	4	2	1	1
X206-1	6	1	1	1
X206-1LD	6	1	1	1
X208	8	-	1	1
X208PRO	8 <sup>1)</sup>	-	1 <sup>2)</sup>	1 <sup>3)</sup>
X212-2	12	2	1	1
X212-2LD	12	2	1	1
X216	16	-	1	1
X224	24	-	1	1
XF204	4	-	1	1
XF204-2	4	2	1	1
XF206-1	6	1	1	1
XF208	8	-	1	1
X202-2IRT	2	2	1	1
X204IRT	4	-	1	1
XF204IRT	4	-	1	1

1) Exception X208PRO: Connection via 4-pin, d-coded M12 socket, IP65/67.

2) Exception X208PRO: Connection via 4-pin, a-coded M12 socket, IP65/67.

3) Exception X208PRO: Connection via 5-pin, b-coded M12 socket, IP65/67.

Type	Connectors for end devices or network components via twisted pair RJ-45 jacks with MDI X pinning 10/100 Mbps (half / full duplex)	Connections for end devices or network components via FO cable SC RJ jacks (push-pull) (100 Mbps, full duplex to 100BaseFX)	Connector for power supply 4-pin plug-in terminal block, redundant	Connector for signaling contact 2-pin plug-in terminal block
X200-4P IRT	-	4	1	1
X201-3P IRT	1	3	1	1
X202-2P IRT	2	2	1	1

Type	Slots for bus adapters	Connector for power supply 2-terminal plug-in block	Connector for signaling contact 2-terminal plug-in block
XF204-2BA IRT	2	2	1

Type	Connectors for end devices or network components via twisted pair RJ-45 jacks with MDI X pinning 10/100 Mbps half / full duplex	Connections for end devices or network components via FO cable SC RJ jacks (push-pull), 100 Mbps, full duplex to 100BaseFX	Connector for power supply 5-pin Power Plug PRO connector (male)	Connector for signaling contact 5-pin b-coded M12 connector (male)
X201-3P IRT PRO	1	3	2	1
X202-2P IRT PRO	2	2	2	1
X204IRT PRO	4	-	2	1

### Signaling contact

The following applies to all devices:

- Voltage for the signaling contact: 24 VDC
- Current through the signaling contact: maximum 100 mA
- Resistor between F1-F2: < 8 ohms

### Electrical data

Type	Supply voltage with redundant connection Rated voltage 12 to 24 VDC SELV Voltage range 10 VDC to 28.8 VDC Permitted voltage range incl. total ripple 10 VDC to 30.2 VDC	Power loss at 12 VDC	Current consumption at rated voltage	Overcurrent protection at input Non-replaceable fuse (F)
X204-2TS	+	6.60 W	600 mA	3.0 A / 32 V
X204-2LD TS	+	6.60 W	600 mA	3.0 A / 32 V

Type	Supply voltage with redundant connection Rated voltage 24 VDC Voltage range 19.2 VDC to 28.8 VDC Permitted voltage range incl. total ripple 18.5 VDC to 30.2 VDC	Power loss at 24 VDC	Current consumption at rated voltage	Overcurrent protection at input PTC resettable fuse
X204-2	+	6.36 W	265 mA	600 mA / 60 V
X204-2FM	+	6.36 W	265 mA	600 mA / 60 V
X204-2LD	+	6.36 W	265 mA	600 mA / 60 V
X206-1	+	5.28 W	220 mA	600 mA / 60 V
X206-1LD	+	5.28 W	220 mA	600 mA / 60 V
X208	+	3.84 W	185 mA	600 mA / 60 V
X208PRO	+	4.4 W	185 mA	600 mA / 60 V

Type	Supply voltage with redundant connection Rated voltage 24 VDC Voltage range 19.2 VDC to 28.8 VDC Permitted voltage range incl. total ripple 18.5 VDC to 30.2 VDC	Power loss at 24 VDC	Current consumption at rated voltage	Overcurrent protection at input PTC resettable fuse
X212-2	+	7.92 W	330 mA	1.1 A / 33 V
X212-2LD	+	7.92 W	330 mA	1.1 A / 33 V
X216	+	5.76 W	240 mA	1.1 A / 33 V
X224	+	8.40 W	350 mA	1.1 A / 33 V
XF204	+	2.64 W	110 mA	1.1 A / 33 V
XF204-2	+	5.28 W	220 mA	1.1 A / 33 V
XF206-1	+	4.08 W	170 mA	1.1 A / 33 V
XF208	+	3.12 W	130 mA	1.1 A / 33 V
X200-4P IRT	+	9.6 W	400 mA	1.1 A / 33 V
X201-3P IRT	+	8.4 W	350 mA	1.1 A / 33 V
X201-3P IRT PRO	no redundancy	7.2 W	300 mA	1.1 A / 33 V
X202-2IRT	+	6.0 W	300 mA	600 mA / 60 V
X202-2P IRT	+	7.2 W	300 mA	1.1 A / 33 V
X202-2P IRT PRO	no redundancy	7.2 W	300 mA	1.1 A / 33 V
X204IRT	+	4.8 W	200 mA	600 mA / 60 V
X204IRT PRO	no redundancy	4.8 W	200 mA	600 mA / 60 V
XF204IRT	+	4.8 W	200 mA	600 mA / 60 V
XF204-2BA IRT <sup>1)</sup>	+	2.4 W	100 mA	2.5 A (non-replaceable fuse F)

1) With the specified power loss and current consumption these are the values of the basic device without plugged in bus adapters. The values change depending on the port types of the plugged in bus adapters. Per port you need to add the following values to the values of the basic device:

Port type	Power loss	Current consumption
RJ-45	0.6 W	25 mA
SCRJ	1.8 W	75 mA

### Examples

The following table shows the power loss and current consumption as an example for the basic device with different bus adapters:

Type	Plugged in bus adapter	Port types	Power loss	Current consumption
XF204-2BA IRT	2 bus adapter BA 2xRJ-45	4 x RJ-45	4.8 W	200 mA
	2 bus adapters BA 2xSCRJ	4 x SCRJ	9.6 W	400 mA
	1 bus adapter BA 2xSCRJ	3 x SCRJ + 1 x RJ-45	8.4 W	350 mA
	1 bus adapter BA SCRJ/RJ-45			



## Optical data

Type	Transmitter output (optical)		Receiver input	
	min. [dBm]	max. [dBm]	Sensitivity min. [dBm]	Input power max. [dBm]
X204-2 X204-2TS X204-2FM X206-1 X212-2 XF204-2 XF206-1 X202-2IRT	-19	-14	-32	-3
X204-2LD X204-2LD TS X206-1LD X212-2LD	-15	-8	-34	-3
X200-4P IRT X201-3P IRT X201-3P IRT PRO X202-2P IRT X202-2P IRT PRO	-8	-2	-23	+1

Type	Transmitter output (optical)				Receiver input			
	min. [dBm]		max. [dBm]		Sensitivity min. [dBm]		Input power max. [dBm]	
XF204-2BA IRT (with corresponding bus adapters)	POF cable	HCS cable	POF cable	HCS cable	POF cable	HCS cable	POF cable	HCS cable
	-8	-19	-4.5	-11	-23	-26.8	+1	-4

## Permitted cable lengths - copper

### For devices with degree of protection IP20/30

The following cables are permitted in the specified lengths:

- **0 to 55 m:**  
IE TP torsion cable with IE FC RJ-45 Plug 180
  - Alternative:  
0 to 45 m IE TP Torsion Cable + 10 m TP Cord via IE Outlet RJ-45
- **0 to 85 m:**  
IE FC TP marine / trailing / flexible / FRNC / festoon / food cable with IE FC RJ-45 Plug 180
  - Alternative:  
0 to 75 m IE FC TP marine / trailing / flexible / FRNC / festoon / food cable + 10 m TP cord over IE FC outlet RJ-45
- **0 to 100 m:**  
IE FC TP standard cable with IE FC RJ-45 plug 180
  - Alternative:  
0 to 90 m IE FC TP standard cable + 10 m TP cord via IE FC outlet RJ-45

**For devices with the "PRO" supplement (degree of protection IP65)**

With these devices, splitting of the cables (as above) is not permitted. The following cables are permitted in the specified lengths:

- **0 to 55 m:**  
IE TP torsion cable with IE FC RJ-45 Plug 180
- **0 to 85 m:**  
IE FC TP marine / trailing / flexible / FRNC / festoon / food cable with IE FC RJ-45 Plug 180
- **0 to 100 m:**  
IE FC TP standard cable with IE FC RJ-45 plug 180

**For X208PRO (degree of protection IP65/67)**

With the X208PRO, splitting of the cables (as above) is not permitted either. The following cables are permitted in the specified lengths:

- **0 to 55 m:**  
IE TP torsion cable with IE FC M12 Plug PRO
- **0 to 85 m:**  
IE FC TP marine / trailing / flexible / FRNC / festoon / food cable with IE FC M12 Plug PRO
- **0 to 100 m:**  
IE FC TP standard cable with IE FC M12 plug PRO

**Permitted cable lengths - fiber-optic**

Type	1 - 50 m 980/1000 plastic optical fiber (POF)	1 - 100 m 200/230 polymer clad fiber (PCF) 6 dB max. permitted cable attenuation with 3 dB link power margin	0 - 4000 Glass FO cable 62.5/125 µm glass fibers 0 - 5000 Glass FO cable 50/125 µm glass fibers ≤ 1 dB/km at 1300 nm; 600 MHz x km; 6 dB max. permitted cable attenuation with 3 dB link power margin	0 - 26000 m glass FO cable 9/125 µm single mode fiber; 0.5 dB/km at 1310 nm; 13 dB max. permitted cable attenuation with 2 dB link power margin
X204-2	-	-	+	-
X204-2TS	-	-	+	-
X204-2FM	-	-	+	-
X204-2LD	-	-	-	+
X204-2LD TS	-	-	-	+
X206-1	-	-	+	-
X206-1LD	-	-	-	+
X212-2	-	-	+	-
X212-2LD	-	-	-	+
XF204-2	-	-	+	-
XF206-1	-	-	+	-
X200-4P IRT	+	+	-	-
X201-3P IRT	+	+	-	-
X201-3P IRT PRO	+	+	-	-

Type	1 - 50 m 980/1000 plastic optical fiber (POF)	1 - 100 m 200/230 polymer clad fiber (PCF) 6 dB max. permitted cable attenuation with 3 dB link power margin	0 - 4000 Glass FO cable 62.5/125 µm glass fibers 0 - 5000 Glass FO cable 50/125 µm glass fibers ≤ 1 dB/km at 1300 nm; 600 MHz x km; 6 dB max. permitted cable attenuation with 3 dB link power margin	0 - 26000 m glass FO cable 9/125 µm single mode fiber; 0.5 dB/km at 1310 nm; 13 dB max. permitted cable attenuation with 2 dB link power margin
X202-2IRT	-	-	+	-
X202-2P IRT	+	+	-	-
X202-2P IRT PRO	+	+	-	-

### Degree of protection and MTBF

Type	Degree of protection	MTBF
X204-2	IP30	64 years
X204-2TS	IP20	63 years
X204-2FM	IP30	87 years
X204-2LD	IP30	60 years
X204-2LD TS	IP20	85 years
X206-1	IP30	72 years
X206-1LD	IP30	69 years
X208	IP30	83 years
X208PRO	IP65/67	83 years
X212-2	IP30	46 years
X212-2LD	IP30	43 years
X216	IP30	52 years
X224	IP30	45 years
XF204	IP20	48 years
XF204-2	IP20	60 years
XF206-1	IP20	69 years
XF208	IP20	54 years
X200-4P IRT	IP30	73 years
X201-3P IRT	IP30	78 years
X201-3P IRT PRO	IP65	85 years
X202-2IRT	IP30	62 years
X202-2P IRT	IP30	84 years
X202-2P IRT PRO	IP65	85 years
X204IRT	IP30	81 years
X204IRT PRO	IP65	99 years
XF204IRT	IP20	81 years
XF204-2BA IRT	IP20	78 years

## Switching properties

Type	Max. number of learnable addresses	Aging time	Switching technique	Latency
X-200	8000	30 s	Store and forward	5 µs
XF-200	8000	30 s	Store and forward	5 µs
X-200IRT	4096	30 s (configurable)	Store and forward / cut through	< 5 µs
XF-200IRT	4096	30 s (configurable)	Store and forward / cut through	< 5 µs

## PRP compatibility

For a device to be used in PRP networks, it must be able to process a frame length of at least 1528 bytes (Jumbo Frames). This value is the maximum frame length including VLAN tag of 1522 bytes plus the length of the PRP trailer of 6 bytes. The following table shows the version as of which the devices are PRP compatible.

Type	As of version *
X204-2	V4.4
X204-2TS	V4.4
X204-2FM	HS 1
X204-2LD	V4.4
X204-2LD TS	HS 1
X206-1	V4.4
X206-1LD	V4.4
X208	V4.4
X208PRO	V4.4
X212-2	V4.4
X212-2LD	V4.4
X216	V4.4
X224	V4.4
XF204	V4.4
XF204-2	V4.4
XF206-1	V4.4
XF208	V4.4
X200-4P IRT	V1.0
X201-3P IRT	V1.0
X201-3P IRT PRO	V1.0
X202-2IRT	V1.0
X202-2P IRT	V1.0
X202-2P IRT PRO	V1.0
X204IRT	V1.0
X204IRT PRO	V1.0
XF204IRT	V1.0
XF204-2BA IRT	HS 1

\* Information about the hardware release (HS) or the firmware version (V) as of which PRP is supported.

## Permitted ambient conditions

### Note

#### Note the mounting position for XF and TS devices

With the following switches an ambient temperature of maximum +40 °C is permitted if the device is installed on a vertical rail:

- XF204
- XF208
- XF204-2
- XF206-1
- XF204IRT
- X204-2TS
- X204-2LD TS

Type	Operating temperature	Storage/transport temperature	Rel. humidity in operation (no condensation)	Operating altitude at max. xx °C ambient temperature
X204-2	-40 °C to +60 °C	-40 °C to +70 °C	< 95 %	2000 m at max. 56 °C 3000 m at max. 50 °C
X204-2TS	-40 °C to +70 °C *)	-40 °C to +70 °C	< 95 %	2000 m at max. 56 °C 3000 m at max. 50 °C
X204-2FM	-40 °C to +60 °C	-40 °C to +70 °C	< 95 %	2000 m at max. 56 °C 3000 m at max. 50 °C
X204-2LD	-40 °C to +60 °C	-40 °C to +70 °C	< 95 %	2000 m at max. 56 °C 3000 m at max. 50 °C
X204-2LD TS	-40 °C to +70 °C *)	-40 °C to +70 °C	< 95 %	2000 m at max. 56 °C 3000 m at max. 50 °C
X206-1	-40 °C to +60 °C	-40 °C to +70 °C	< 95 %	2000 m at max. 56 °C 3000 m at max. 50 °C
X206-1LD	-40 °C to +60 °C	-40 °C to +70 °C	< 95 %	2000 m at max. 56 °C 3000 m at max. 50 °C
X208	-40 °C to +60 °C	-40 °C to +70 °C	< 95 %	2000 m at max. 56 °C 3000 m at max. 50 °C
X208PRO	-40 °C to +70 °C	-40 °C to +70 °C	< 95 %	2000 m at max. 56 °C 3000 m at max. 50 °C
X212-2	-40 °C to +60 °C	-40 °C to +70 °C	< 95 %	2000 m at max. 56 °C 3000 m at max. 50 °C
X212-2LD	-40 °C to +60 °C	-40 °C to +70 °C	< 95 %	2000 m at max. 56 °C 3000 m at max. 50 °C
X216	-40 °C to +60 °C	-40 °C to +70 °C	< 95 %	2000 m at max. 56 °C 3000 m at max. 50 °C
X224	-40 °C to +60 °C	-40 °C to +70 °C	< 95 %	2000 m at max. 56 °C 3000 m at max. 50 °C
XF204	-40 °C to +60 °C *)	-40 °C to +70 °C	< 95 %	2000 m at max. 56 °C 3000 m at max. 50 °C
XF204-2	-40 °C to +60 °C *)	-40 °C to +70 °C	< 95 %	2000 m at max. 56 °C 3000 m at max. 50 °C
XF206-1	-40 °C to +60 °C *)	-40 °C to +70 °C	< 95 %	2000 m at max. 56 °C 3000 m at max. 50 °C

Type	Operating temperature	Storage/transport temperature	Rel. humidity in operation (no condensation)	Operating altitude at max. xx °C ambient temperature
XF208	-40 °C to +60 °C *)	-40 °C to +70 °C	< 95 %	2000 m at max. 56 °C 3000 m at max. 50 °C
X200-4P IRT	-25 °C to +40 °C	-40 °C to +70 °C	< 95 %	2000 m at max. 35 °C 3000 m at max. 30 °C
X201-3P IRT	-25 °C to +50 °C	-40 °C to +70 °C	< 95 %	2000 m at max. 45 °C 3000 m at max. 40 °C
X201-3P IRT PRO	-25 °C to +60 °C	-40 °C to +70 °C	< 95 %	2000 m at max. 56 °C 3000 m at max. 50 °C
X202-2IRT	-40 °C to +60 °C	-40 °C to +70 °C	< 95 %	2000 m at max. 56 °C 3000 m at max. 50 °C
X202-2P IRT	-25 °C to +60 °C	-40 °C to +70 °C	< 95 %	2000 m at max. 56 °C 3000 m at max. 50 °C
X202-2P IRT PRO	-25 °C to +60 °C	-40 °C to +70 °C	< 95 %	2000 m at max. 56 °C 3000 m at max. 50 °C
X204IRT	-40 °C to +70 °C	-40 °C to +70 °C	< 95 %	2000 m at max. 56 °C 3000 m at max. 50 °C
X204IRT PRO	-25 °C to +70 °C	-40 °C to +70 °C	< 95 %	2000 m at max. 56 °C 3000 m at max. 50 °C
XF204IRT	-40 °C to +60 °C *)	-40 °C to +70 °C	< 95 %	2000 m at max. 56 °C 3000 m at max. 50 °C

\*) Note the information on the mounting position above.

Type	Plugged in bus adapter	Operating temperature	Storage/transport temperature	Rel. humidity in operation (no condensation)	Operating altitude at max. xx °C ambient temperature
XF204-2BA IRT	-	-40 °C to +60 °C	-40 °C to +85 °C	< 95 %	2000 m at max. 56 °C 3000 m at max. 50 °C
	2 bus adapter BA 2×RJ-45 <sup>1)</sup>	0 °C to +60 °C			2000 m at max. 56 °C 3000 m at max. 50 °C
	2 bus adapters BA 2×RJ-45 (coated) <sup>1)</sup>	-40 °C to +60 °C			2000 m at max. 56 °C 3000 m at max. 50 °C
	2 bus adapters BA 2xSCRJ	0 °C to +50 °C			2000 m at max. 45 °C 3000 m at max. 40 °C
	2 bus adapters BA 2xSCRJ (coated)	-40 °C to +50 °C (startup at -25 °C)			2000 m at max. 45 °C 3000 m at max. 40 °C
	2 bus adapters BA SCRJ/ RJ45 <sup>1)</sup>	0 °C to +55 °C			2000 m at max. 50 °C 3000 m at max. 45 °C
	1 bus adapter BA 2xSCRJ 1 bus adapter BA SCRJ/ RJ45 <sup>1)</sup>	0 °C to +50 °C			2000 m at max. 45 °C 3000 m at max. 40 °C
	1 bus adapter BA 2×RJ-45 <sup>1)</sup> 1 bus adapter BA SCRJ/ RJ45 <sup>1)</sup>	0 °C to +55 °C			2000 m at max. 50 °C 3000 m at max. 45 °C
	1 bus adapter BA 2xSCRJ 1 bus adapter BA 2×RJ-45 <sup>1)</sup>	0 °C to +50 °C			2000 m at max. 45 °C 3000 m at max. 40 °C

1) Bus adapters with FC interfaces have the same temperature values as bus adapters with RJ-45 interfaces.

## Frame delay times

The number of IE Switches X-200 connected in a line influences the frame delay.

---

### Note

#### Frame delay time with X-200 without IRT

When a frame passes through X-200 IE switches, it is delayed by the Store&Forward function of the X-200 IE switches.

- With a 64 byte frame length by approx. 10 microseconds (at 100 Mbps).
- With a 1500 byte frame length by approx. 130 microseconds (at 100 Mbps).

This means that the more X-200 IE switches the frame passes through, the longer the frame delay.

---

### Note

#### Frame delay time with X-200 with IRT

The more X-200IRT IE switches a frame runs through, the higher the frame delay. By using the "cut through" switching mechanism, the X-200IRT IE switches are ideal to meet the real-time requirements of PROFINET.

Cut through is, however, not possible:

- Between a port set to 10 Mbps and a port set to 100 Mbps.
- When two packets are to be sent at the same time on one port.  
In this case, an X-200 IE switch changes to Store&Forward and the delay increases.

---

## Hardware version

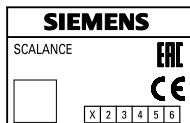

You will find the hardware version of your device on the type plate. On the type plate, the hardware version is printed as a placeholder "X".

Example: X 2 3 4 5 6

In this case, "X" would be the placeholder for hardware version 1.





# Approvals

## Approvals issued

---

### Note

#### Issued approvals on the type plate of the device

The specified approvals apply only when the corresponding mark is printed on the product. You can check which of the following approvals have been granted for your product by the markings on the type plate.

Approvals for shipbuilding are not printed on the device type plate.

---

## Current approvals on the Internet

You will find the current approvals for the product on the Internet pages of Siemens Industry Online Support (<https://support.industry.siemens.com/cs/ww/en/ps/15273/cert>).

## Notes for the manufacturers of machines

The devices are not machines in the sense of the EC Machinery Directive. There is therefore no declaration of conformity relating to the EC Machinery Directive 2006/42/EC for these devices.

If the devices are part of the equipment of a machine, they must be included into the EU declaration of conformity procedure by the manufacturer of the machine.

## See also

SIMATIC NET Industrial Ethernet TP and Fiber Optic Networks (<http://support.automation.siemens.com/WW/view/en/8763736>)

## EC declaration of conformity



The SIMATIC NET products described in these operating instructions meet the requirements and safety objectives of the following EC directives and comply with the harmonized European

standards (EN) which are published in the official documentation of the European Union and here.

- **2014/34/EU (ATEX explosion protection directive)**  
Directive of the European Parliament and the Council of 26 February 2014 on the approximation of the laws of the member states concerning equipment and protective systems intended for use in potentially explosive atmospheres, official journal of the EU L96, 29/03/2014, pages. 309-356
- **2014/30/EU (EMC)**  
EMC directive of the European Parliament and of the Council of February 26, 2014 on the approximation of the laws of the member states relating to electromagnetic compatibility; official journal of the EU L96, 29/03/2014, pages. 79-106
- **2011/65/EU (RoHS)**  
Directive of the European Parliament and of the Council of 8 June 2011 on the restriction of the use of certain hazardous substances in electrical and electronic equipment, official journal of the EC L174, 01/07/2011, pages 88-110

You will find the EC declaration of conformity for these products on the Internet pages of Siemens Industry Online Support (<https://support.industry.siemens.com/cs/ww/en/ps/15273/cert>).

The EC Declaration of Conformity is available for all responsible authorities at:

Siemens Aktiengesellschaft  
Division Process Industries and Drives  
Process Automation  
DE-76181 Karlsruhe  
Germany

### ATEX (explosion protection directive)

 <b>WARNING</b>
<b>Risk of explosion in hazardous areas</b>
When using SIMATIC NET products in hazardous area zone 2, make absolutely sure that the associated conditions in the following document are adhered to: "SIMATIC NET Product Information Use of subassemblies/modules in a Zone 2 Hazardous Area".
You will find this document here:
<ul style="list-style-type: none"><li>• On the data medium that ships with some products:<ul style="list-style-type: none"><li>– Product CD / product DVD</li><li>– SIMATIC NET Manual Collection</li></ul></li><li>• On the Internet pages of Siemens Industry Online Support</li></ul>

The SIMATIC NET products described in these operating instructions meet the requirements of the EU directive 2014/34/EU "Equipment and Protective Devices for Use in Potentially Explosive Atmospheres".

---

**Note****Type of protection of the device**

The devices are approved for various types of protection. You can find the type of protection of your device and the ATEX certificate number on the nameplate.

---

**Permitted types of protection**

The following types of protection are possible:

- nA  
ATEX classification: II 3G Ex nA IIC T4 Gc  
Certificate no.: KEMA 07ATEX0145 X  
The products meet the requirements of the following standards:
  - EN 60079-15 (Explosive atmospheres - Part 15: Equipment protection by type of protection "n")
  - EN 60079-0 (Explosive atmospheres - Part 0: Equipment - General requirements)
- nA [op is]  
ATEX classification: II 3 (2) G Ex nA [op is Gb] IIC T4 Gc  
Certificate no.: DEKRA 11ATEX0060 X  
The products meet the requirements of the following standards:
  - EN 60079-28 (Explosive atmospheres - Part 28: Protection of equipment and transmission systems using with optical radiation)
  - EN 60079-15 (Explosive atmospheres - Part 15: Equipment protection by type of protection "n")
  - EN 60079-0 (Explosive atmospheres - Part 0: Equipment - General requirements)
- ec  
ATEX classification: II 3 G Ex ec IIC T4 Gc  
Certificate no.: DEKRA 18ATEX0025 X  
The products meet the requirements of the following standards:
  - EN 60079-7 (Explosive atmospheres - Part 7: Equipment protection through increased safety "e")
  - EN 60079-0 (Explosive atmospheres - Part 0: Equipment - General requirements)

You will find the current versions of the standards in the currently valid ATEX certificates.

**See also**

SIOS (<https://support.industry.siemens.com/cs/ww/en/view/78381013>)

## IECEX

The SIMATIC NET products described in these operating instructions meet the requirements of explosion protection according to IECEx.

---

### Note

#### Type of protection of the device

The devices are approved for various types of protection. You can find the type of protection of your device and the IECEx certificate number on the nameplate.

---

#### Permitted types of protection

The following types of protection are possible:

- nA  
IECEX classification: Ex nA IIC T4 Gc  
Certificate no.: DEK 14.0025X  
The products meet the requirements of the following standards:
  - IEC 60079-15 (Explosive atmospheres - Part 15: Equipment protection by type of protection "n")
  - IEC 60079-0 (Explosive atmospheres - Part 0: Equipment - General requirements)
- nA [op is]  
IECEX classification: Ex nA [op is Gb] IIC T4 Gc  
Certificate no.: DEK 14.0026X  
The products meet the requirements of the following standards:
  - IEC 60079-28 (Explosive atmospheres - Part 28: Protection of equipment and transmission systems using with optical radiation)
  - IEC 60079-15 (Explosive atmospheres - Part 15: Equipment protection by type of protection "n")
  - IEC 60079-0 (Explosive atmospheres - Part 0: Equipment - General requirements)
- ec  
IECEX classification: Ex ec IIC T4 Gc  
Certificate no.: DEK 18.0017X  
The products meet the requirements of the following standards:
  - IEC 60079-7 (Explosive atmospheres - Part 7: Equipment protection through increased safety "e")
  - IEC 60079-0 (Explosive atmospheres - Part 0: Equipment - General requirements)

You will find the current versions of the standards in the currently valid IECEx certificates.

## Note for devices with CLASS 1 LASER

Important note on products certified according to Type Examination Certificate KEMA 07ATEX0145 X as of Issue 95 / DEKRA 18ATEX0025X and IECEx Certificate of Conformity DEK 14.0025X as of Issue 43 / DEK 18.0017X and containing Class 1 optical radiation sources.

---

### Note

#### CLASS 1 LASER

The device contains optical radiation sources which comply with the limits of Class 1 according to IEC 60825-1. Fiber-optic cables connected to these optical radiation sources may therefore be routed either to or through hazardous areas requiring Category 2G, 3G, 2D or 3D equipment.

---

## EMC directive (electromagnetic compatibility)

The SIMATIC NET products described in these operating instructions meet the requirements of EU directive 2014/30/EU "Electromagnetic Compatibility" (EMC Directive).

Applied standards:

- EN 61000-6-2 Electromagnetic compatibility (EMC) - Part 6-2: Generic standards - Immunity for industrial environments
- EN 61000-6-4 Electromagnetic compatibility (EMC) - Part 6-4: Generic standards - Emission standard for industrial environments

You will find the current versions of the standards in the currently valid EC declaration of conformity.

## EMC directive (railway applications)

The TS device variant also meets the requirements of the EU Directive 2014/30/EU "Electromagnetic Compatibility" (EMC Directive).

Applied standards:

- EN 50121-3-2 Railway applications - Electromagnetic compatibility - part 3-2: Rolling stock - Devices
- EN 50121-4 Railway applications - Electromagnetic compatibility - part 4: Interference emissions and immunity of signal telecommunications equipment

You will find the current versions of the standards in the currently valid EC declaration of conformity.

## RoHS

The SIMATIC NET products described in these operating instructions meet the requirements of the EC directive 2011/65/EC for the restriction of the use of certain hazardous substances in electrical and electronic equipment:

Applied standard:

- EN 50581

## FM

The product meets the requirements of the standards:

- Factory Mutual Approval Standard Class Number 3611
- FM Hazardous (Classified) Location Electrical Equipment:  
Non Incendive / Class I / Division 2 / Groups A,B,C,D / T4 and  
Non Incendive / Class I / Zone 2 / Group IIC / T4

### **cULus approval for industrial control equipment**

cULus Listed IND. CONT. EQ.

Underwriters Laboratories Inc. complying with

- UL 508
- CSA C22.2 No. 142-M1987

Report no. E85972

### **cULus approval for industrial control equipment**

cULus Listed IND. CONT. EQ.

Underwriters Laboratories Inc. complying with

- UL 61010-2-201
- CAN/CSA-IEC 61010-2-201

Report no. E85972

### **cULus Approval for Information Technology Equipment**

cULus Listed I. T. E.

Underwriters Laboratories Inc. complying with

- UL 60950-1 (Information Technology Equipment)
- CSA C22.2 No. 60950-1-03

Report no. E115352

### **cULus Approval Hazardous Location**

cULus Listed I. T. E. FOR HAZ. LOC.

Underwriters Laboratories Inc. complying with

- UL 60950-1 (Information Technology Equipment)
- ANSI/ISA 12.12.01-2007
- CSA C22.2 No. 213-M1987

Approved for use in  
Cl. 1, Div. 2, GP A, B, C, D T4  
Cl. 1, Zone 2, GP IIC T4

Report no. E240480

### Note for Australia - RCM

The product meets the requirements of the RCM standard.

Applied standards:

- AS/NZS CISPR11 (Industrial, scientific and medical equipment - Radio-frequency disturbance characteristics - Limits and methods of measurement).
- EN 61000-6-4 Electromagnetic compatibility (EMC) - Part 6-4: Generic standards - Emission standard for industrial environments

You will find the current versions of the standards in the currently valid RCM SDoCs (Self-Declaration of Conformity).

### MSIP 요구사항 - For Korea only

**A급 기기(업무용 방송통신기자재)**

이 기기는 업무용(A급) 전자파 적합기기로서 판매자 또는 사용자는 이 점을 주의하시기 바라며, 가정 외의 지역에서 사용하는 것을 목적으로 합니다.

### Marking for the customs union



EAC (Eurasian Conformity)

Eurasian Economic Union of Russia, Belarus, Armenia, Kazakhstan and Kyrgyzstan

Declaration of conformity according to the technical regulations of the customs union (TR ZU)

### Shipbuilding

Note that the approvals for shipbuilding with the SCALANCE XF204-2BA IRT are valid with all bus adapters, see section "Accessories (Page 24)".

### CSA Approval for Information Technology Equipment

CSA Certification Mark

Canadian Standard Association CSA C22.2 No. 60950-1-03

### CSA Approval for Industrial Control Equipment

CSA Certification Mark

Canadian Standard Association CSA C22.2 No. 142-1987

**FDA and IEC marking**

The following devices meet the FDA and IEC requirements listed below:

Device	CLASS 1 LASER Product
SCALANCE X200-4P IRT	•
SCALANCE X201-3P IRT	•
SCALANCE X201-3P IRT PRO	•
SCALANCE X202-2IRT	•
SCALANCE X202-2P IRT	•
SCALANCE X202-2P IRT PRO	•
SCALANCE X204-2	•
SCALANCE X204-2 TS	•
SCALANCE X204-2FM	•
SCALANCE XF204-2	•
SCALANCE X204-2LD	•
SCALANCE X204-2LD TS	•
SCALANCE X206-1	•
SCALANCE XF206-1	•
SCALANCE X206-1LD	•
SCALANCE X212-2	•
SCALANCE X212-2LD	•

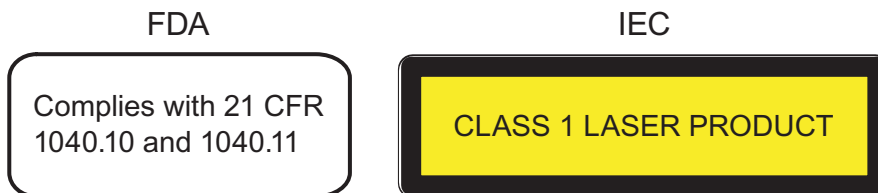

Figure 7-1 FDA and IEC approvals

<p><b>⚠ CAUTION</b></p> <p>Use of controls or adjustments or performance of procedures other than those specified herein may result in hazardous radiation exposure.</p>
--

**Railway approval**

The TS variant of the device meets the requirements of the railway standard

- EN 50155 "Railway applications - Electronic equipment used on rolling stock".

**Note**

When used on railway stock, a stabilized power supply must be used to comply with EN50155.



## Railway approval

The SCALANCE X204-2 TS meets the requirements of the railway standard EN 50155:2007 "Railway Applications - Electronic equipment used on rolling stock".

The two TS device variants SCALANCE X204-2 TS and SCALANCE X204-2LD TS meet the requirements of the railway standard DIN EN 45545-2+A1 "Railway Applications - Fire protection on railway vehicles - Part 2: Requirements for fire behavior of materials and components".

## Installation guidelines

The devices meet the requirements if you adhere to the installation and safety instructions contained in this documentation and in the following documentation when installing and operating the devices.

- "Industrial Ethernet / PROFINET Industrial Ethernet" System Manual (<https://support.industry.siemens.com/cs/ww/en/view/27069465>)
- "Industrial Ethernet / PROFINET - Passive Network Components" System Manual (<https://support.industry.siemens.com/cs/ww/en/view/84922825>)
- "EMC Installation Guidelines" configuration manual (<https://support.industry.siemens.com/cs/ww/en/view/60612658>)



### WARNING

#### Personal injury and property damage can occur

The installation of expansions that are not approved for SIMATIC NET products or their target systems may violate the requirements and regulations for safety and electromagnetic compatibility.

Only use expansions that are approved for the system.

### Note

The test was performed with a device and a connected communications partner that also meets the requirements of the standards listed above.

When operating the device with a communications partner that does not comply with these standards, adherence to the corresponding values cannot be guaranteed.



# Dimension drawings

# A

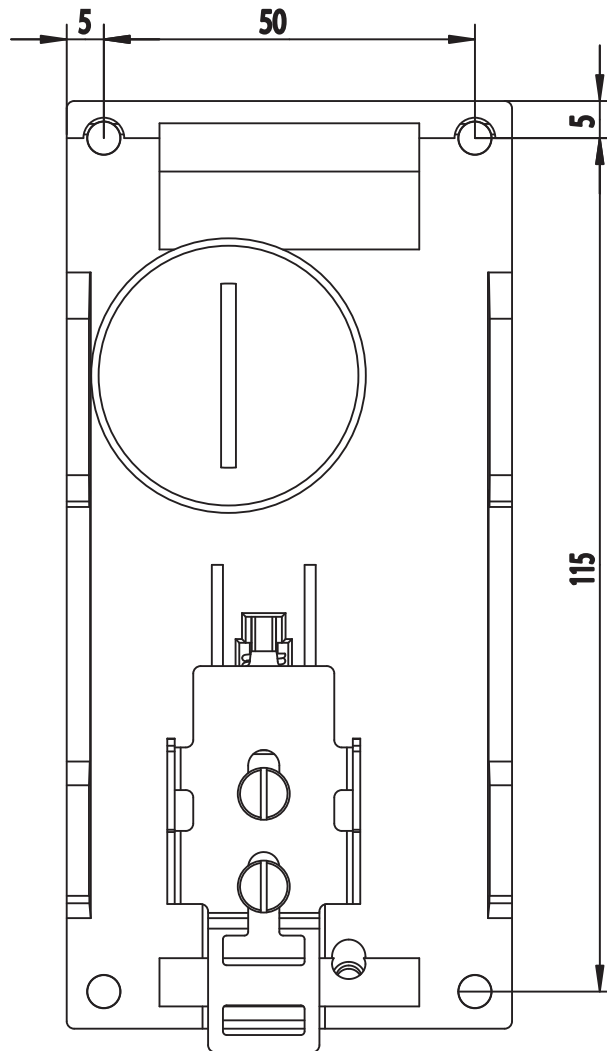

Figure A-1 Drilling pattern SCALANCE X204-2, X204-2TS, X204-2FM, X204-2LD, X204-2LD TS, X206-1, X206-1LD, X208, X200-4P IRT, X201-3P IRT, X202-2IRT, X202-2P IRT, X204IRT

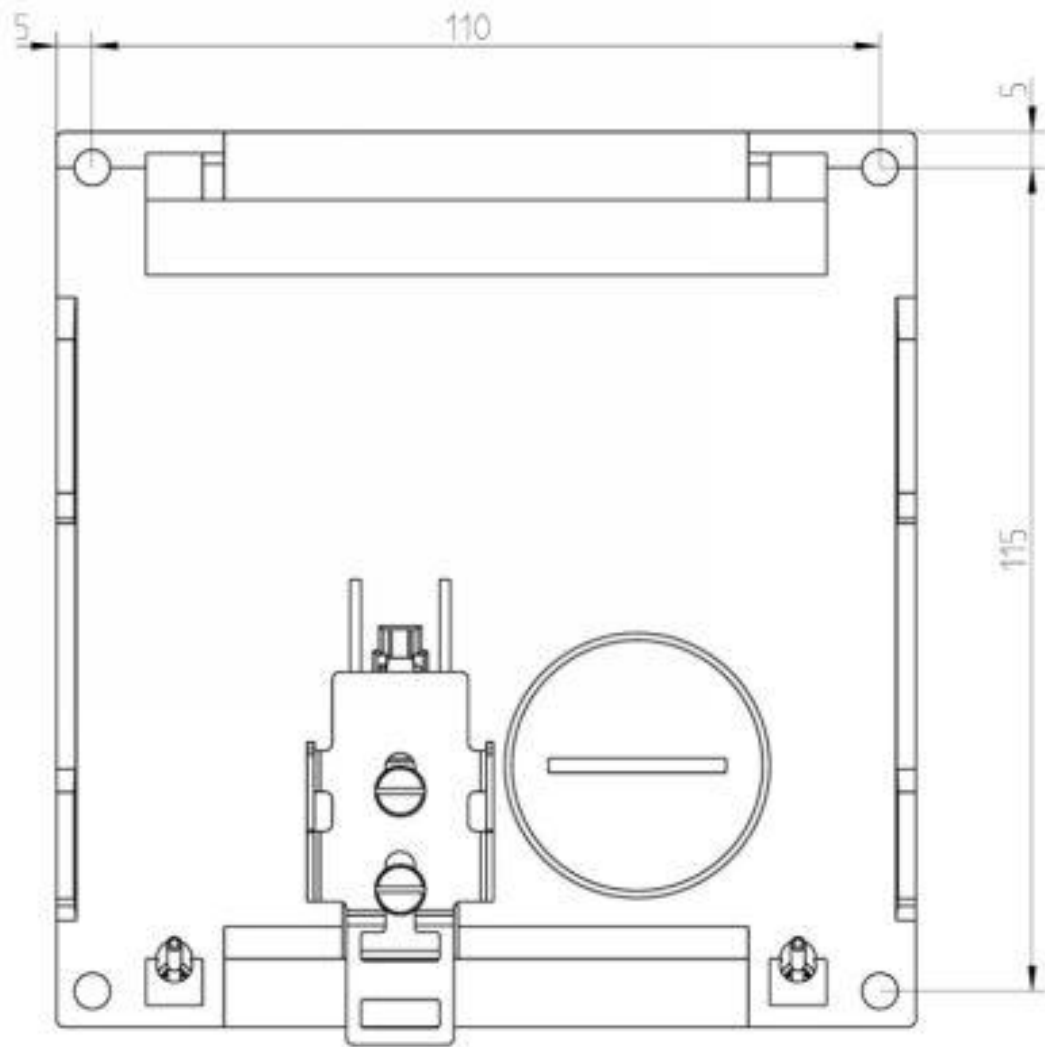

Figure A-2 Drilling pattern SCALANCE X212-2, X212-2LD and X216

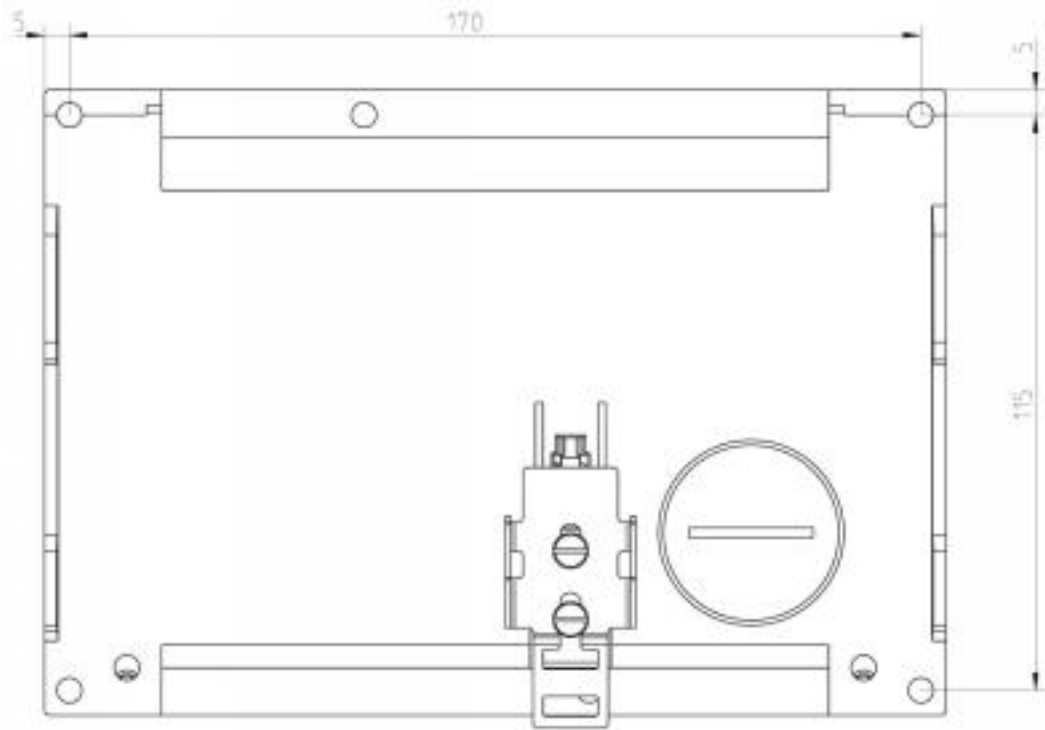

Figure A-3 Drilling pattern SCALANCE X224

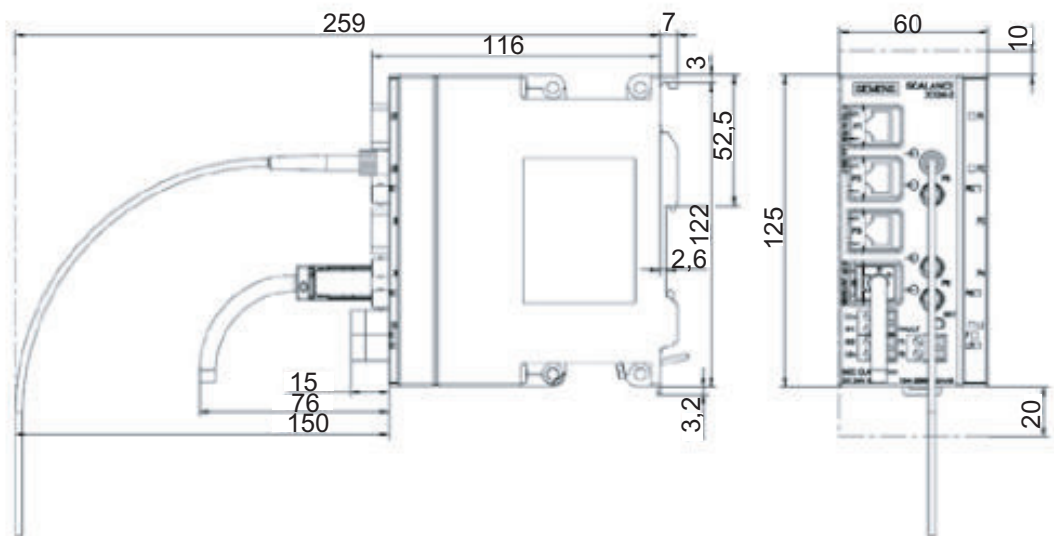

Figure A-4 Side view SCALANCE X-200

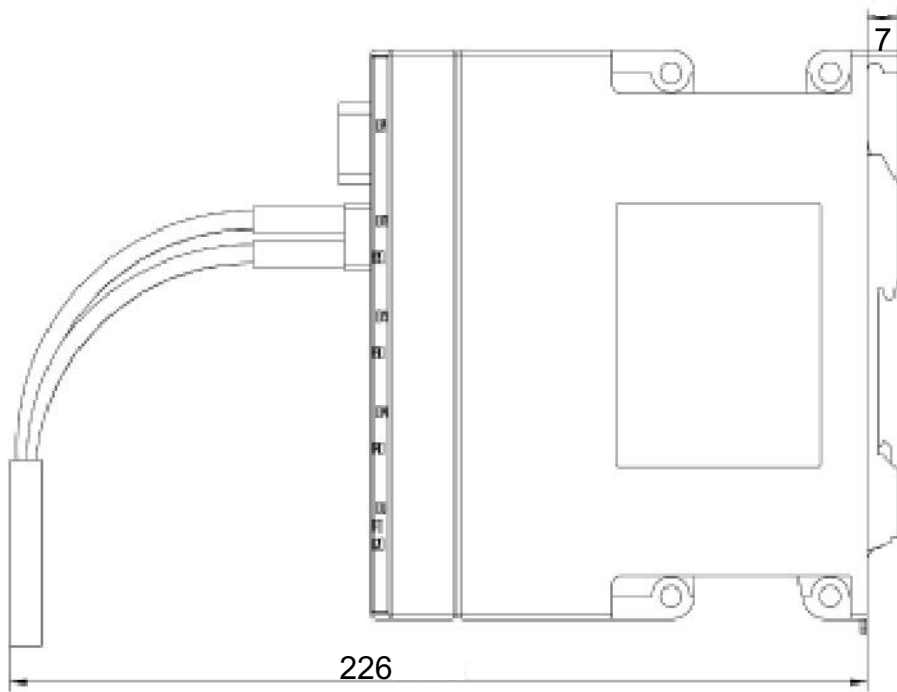

Figure A-5 Side view SCALANCE X-200 POF with POF interface

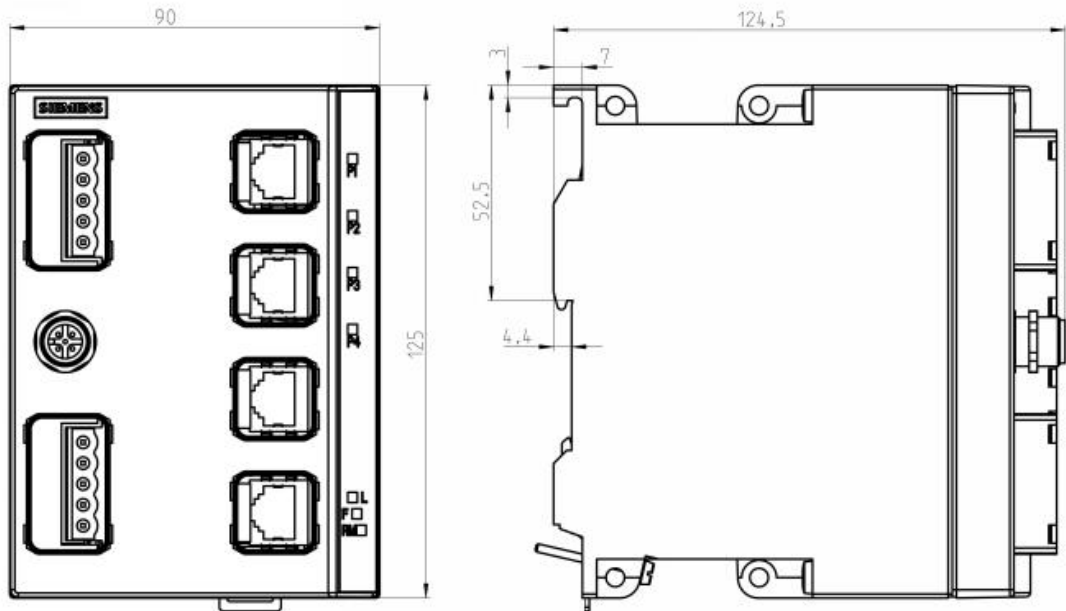

Figure A-6 Dimension drawings of the SCALANCE X208PRO, SCALANCE X201-3P IRT PRO, SCALANCE X202-2P IRT PRO and SCALANCE X204IRT PRO

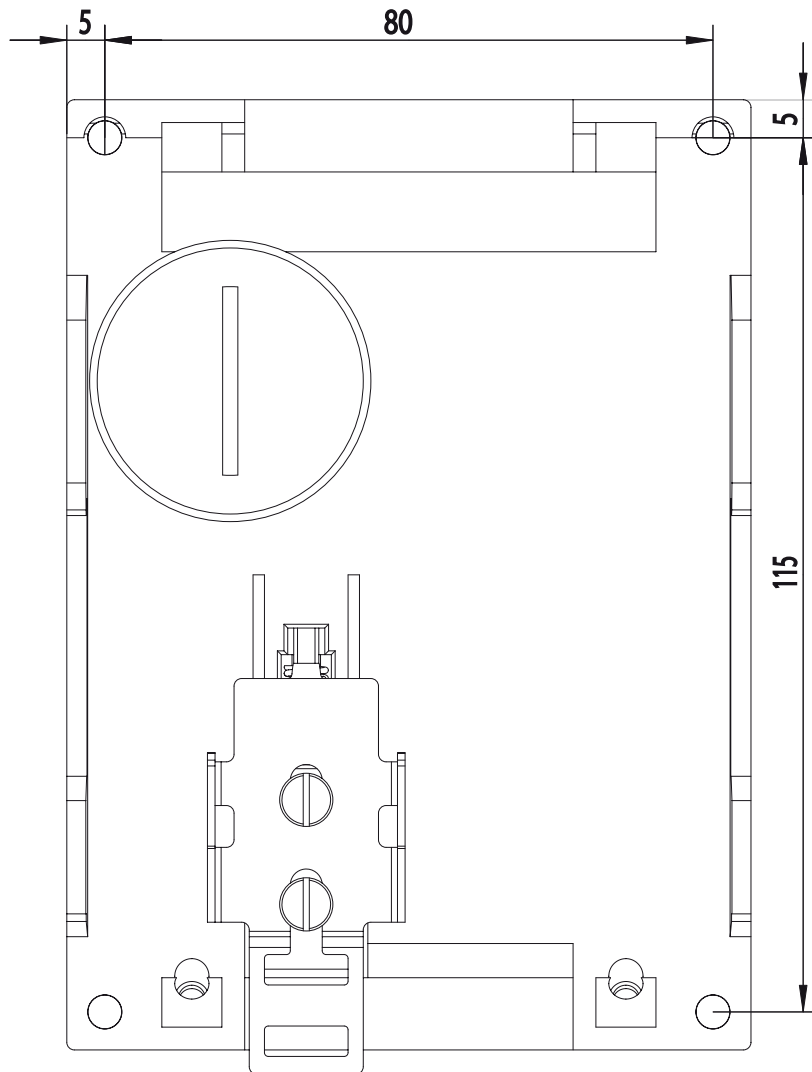

Figure A-7 Drilling pattern of the SCALANCE X208PRO, SCALANCE X201-3P IRT PRO, SCALANCE X202-2P IRT PRO and SCALANCE X204IRT PRO

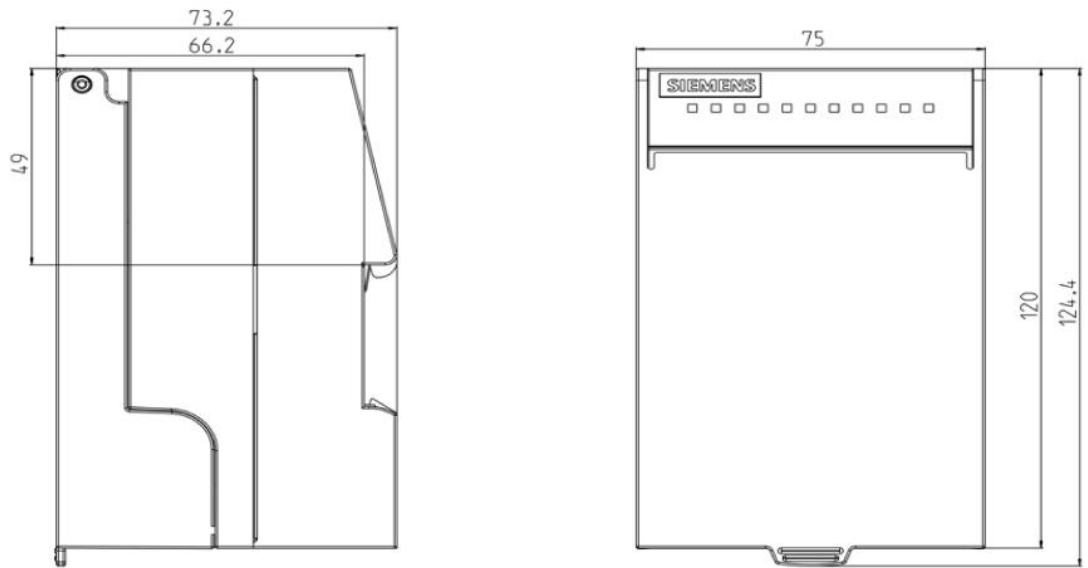

Figure A-8 SCALANCE XF-200 dimension drawings

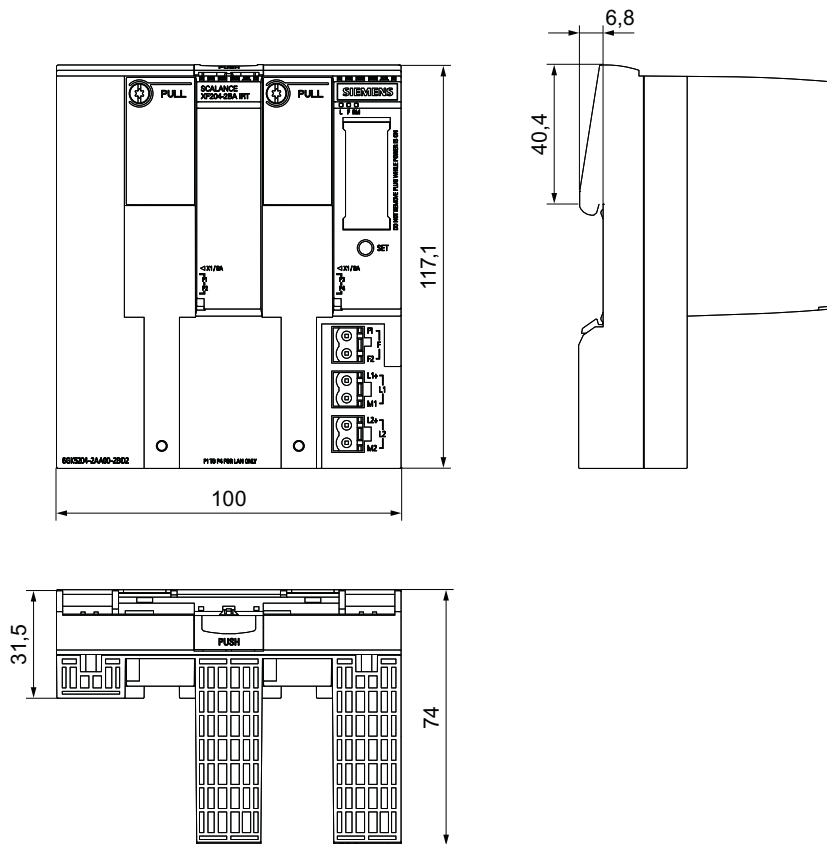

Figure A-9 Dimension drawing SCALANCE XF204-2BA IRT



## Test of mechanical stability

### Mechanical stability

Device type SCALANCE	IEC 60068-2-6 vibration		IEC 60068-2-27 shock	
X204-2	5 – 9 Hz: 3.5 mm 9 – 500 Hz: 1 g 1 octave/min, 20 sweeps		15 g, 6 ms duration 6 shocks per axis	
X204-2TS	5 – 9 Hz: 3.5 mm 9 – 500 Hz: 1 g 1 octave/min, 20 sweeps	5 – 150 Hz: Max. 7.9 g random	15 g, 6 ms duration 6 shocks per axis	50 g, 30 ms duration 6 shocks per axis
X204-2FM	5 – 9 Hz: 3.5 mm 9 – 500 Hz: 1 g 1 octave/min, 20 sweeps		15 g, 6 ms duration 6 shocks per axis	
X204-2LD	5 – 9 Hz: 3.5 mm 9 – 500 Hz: 1 g 1 octave/min, 20 sweeps		15 g, 11 ms duration 6 shocks per axis	
X204-2LD TS	5 – 9 Hz: 3.5 mm 9 – 500 Hz: 1 g 1 octave/min, 20 sweeps	5 – 150 Hz: Max. 7.9 g random	15 g, 6 ms duration 6 shocks per axis	50 g, 30 ms duration 6 shocks per axis
X206-1	5 – 9 Hz: 3.5 mm 9 – 500 Hz: 1 g 1 octave/min, 20 sweeps		15 g, 6 ms duration 6 shocks per axis	
X206-1 LD	5 – 9 Hz: 3.5 mm 9 – 500 Hz: 1 g 1 octave/min, 20 sweeps		15 g, 6 ms duration 6 shocks per axis	
X208	5 – 9 Hz: 3.5 mm 9 – 500 Hz: 1 g 1 octave/min, 20 sweeps		15 g, 6 ms duration 6 shocks per axis	
X208PRO	5 - 9 Hz 3.5 mm 9 - 150 Hz 1 g 10 cycles		15 g, 11 ms duration 6 shocks/axis	
X212-2	5 – 9 Hz: 3.5 mm 9 – 500 Hz: 1 g 1 octave/min, 20 sweeps		15 g, 11 ms duration 6 shocks per axis	
X212-2LD	5 – 9 Hz: 3.5 mm 9 – 500 Hz: 1 g 1 octave/min, 20 sweeps		15 g, 6 ms duration 6 shocks per axis	
X216	5 – 9 Hz: 3.5 mm 9 – 500 Hz: 1 g 1 octave/min, 20 sweeps		15 g, 11 ms duration 6 shocks per axis	
X224	5 – 9 Hz: 3.5 mm 9 – 500 Hz: 1 g 1 octave/min, 20 sweeps		15 g, 11 ms duration 6 shocks per axis	
XF204	5 – 9 Hz: 3.5 mm 9 – 500 Hz: 1 g 1 octave/min, 20 sweeps		15 g, 6 ms duration 6 shocks per axis	

Device type SCALANCE	IEC 60068-2-6 vibration	IEC 60068-2-27 shock
XF204-2	5 – 9 Hz: 3.5 mm 9 – 500 Hz: 1 g 1 octave/min, 20 sweeps	15 g, 6 ms duration 6 shocks per axis
XF206-1	5 – 9 Hz: 3.5 mm 9 – 500 Hz: 1 g 1 octave/min, 20 sweeps	15 g, 6 ms duration 6 shocks per axis
XF208	5 – 9 Hz: 3.5 mm 9 – 500 Hz: 1 g 1 octave/min, 20 sweeps	15 g, 6 ms duration 6 shocks per axis
X200-4P IRT	5 – 9 Hz: 3.5 mm 9 – 500 Hz: 1 g 1 octave/min, 20 sweeps	15 g, 11 ms duration 6 shocks per axis
X201-3P IRT	5 – 9 Hz: 3.5 mm 9 – 500 Hz: 1 g 1 octave/min, 20 sweeps	15 g, 11 ms duration 6 shocks per axis
X201-3P IRT PRO	5 – 9 Hz: 3.5 mm 9 – 150 Hz: 1 g 10 cycles per axis	15 g, 11 ms duration 6 shocks per axis
X202-2IRT	10 - 58 Hz: 0.075 mm 58 - 500 Hz: 1 g 10 cycles per axis	10 g, 16 ms duration 6 shocks per axis
X202-2P IRT	5 – 9 Hz: 3.5 mm 9 – 500 Hz: 1 g 1 octave/min, 20 sweeps	15 g, 11 ms duration 6 shocks per axis
X202-2P IRT PRO	5 – 9 Hz: 3.5 mm 9 – 150 Hz: 1 g 10 cycles per axis	15 g, 11 ms duration 6 shocks per axis
X204IRT	10 - 58 Hz: 0.075 mm 58 - 500 Hz: 1 g 10 cycles per axis	10 g, 16 ms duration 6 shocks per axis
X204IRT PRO	5 – 9 Hz: 3.5 mm 9 – 150 Hz: 1 g 10 cycles per axis	15 g, 11 ms duration 6 shocks per axis
XF204IRT	10 - 58 Hz: 0.075 mm 58 - 500 Hz: 1 g 10 cycles per axis	10 g, 16 ms duration 6 shocks per axis
XF204-2BA IRT	10 - 58 Hz: 0.075 mm 58 - 500 Hz: 1 g 10 cycles per axis	10 g, 16 ms duration 6 shocks per axis

### Note

The interfaces of the X-200 IE switches can be divided into groups each with 4 ports:

- P1 to P4
- P5 to P8
- P9 to P12
- etc.

If only ports of different port groups are used, the device meets the requirements for Environment B in compliance with IEEE 802.3, Section 33.4.1.1. If ports of the same port group are used, the requirements for Environment A are met.

# Index

## A

Approvals, 81  
Article number, 3  
    C-PLUG, 24  
    Power Plug PRO, 54  
    Redundancy module, 24  
    RJ-45 data plug-in connector, 24  
    SC RJ plug-in connector, 25  
Auto polarity exchange, 62  
Autonegotiation, 62

## B

Bus adapter, 25

## C

CE mark, 81  
Components of the product, 20

## E

ESD directives, 7  
Extension module, 24, 49

## F

Factory settings, 31  
Frame delay times, 18  
Function, 17

## G

GI-PCF, 67  
Glossary, 5

## I

Installation  
    Installation on a DIN rail, 43  
Installation on a DIN rail, 43

## M

MDI / MDI-X autocrossover, 62, 63

## N

Node localization, 30  
Number of connectors, 19

## O

Order number  
    C-PLUG, 33  
Overview of the functions, 19

## P

Polarity reversal, 62  
Power limiter, 24, 49  
Power Plug PRO  
    Article number, 54

## R

Redundancy module, 49  
Reference identification plate, 26

## S

Safety notices  
    general, 11  
    Use in hazardous areas, 11, 49  
    when connecting up, 49  
SET button, 31  
SIMATIC NET glossary, 5  
SIMATIC NET manual, 5  
System manual, 5, 89

