

SONY®

4-690-450-E3(1)

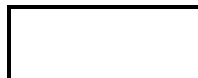

Television

Reference Guide



Lea este manual antes de usar el producto

Centro de Asistencia de Sony

<http://esupport.sony.com/ES/LA/>

Llame al número telefónico que aparece en su póliza de garantía.

Por favor no devuelva el producto a la tienda donde adquirió el producto.

BRAVIA

XBR-75X900E / 75X850E / 65X900E / 65X850E / 55X900E

Table of Contents

IMPORTANT NOTICE	2
Safety information	3
Precautions	6
Parts and Controls	8
Controls and Indicators	8
Using Remote Control	9
Remote Control Parts Description	9
Connection Diagram	11
Installing the TV to the Wall	13
Detaching the Table-Top Stand from the TV	15
Installing the TV against a wall or enclosed area	16
Troubleshooting	17
Troubles and Solutions	17
Specifications	18

Introduction

Thank you for choosing this Sony product. Before operating the TV, please read this manual thoroughly and retain it for future reference.

Note

- Images and illustrations used in the Setup Guide and this manual are for reference only and may differ from the actual product.

The 75" class has a 74.5 inch (189.3 cm) viewable image size, the 65" class has a 64.5 inch (163.9 cm) viewable image size and the 55" class has a 54.6 inch (138.8 cm) viewable image size (measured diagonally).

Location of the Setup Guide

Setup Guide is placed on top of the cushion inside the TV carton.

Help/Help Guide

Help feature offers a lot of information about your TV. To use the Help feature, press **HELP** on the remote control. You can find how to and troubleshooting from the list or keyword search. Select [Help Guide] on Help menu to view the manual. If you connect your TV to the internet, the Help feature and information will be updated.

Location of the identification label

Labels for the TV Model No. and Power Supply rating are located on the rear of the TV.

For models with supplied AC adapter:

Labels for the AC adapter Model No. and Serial No. are located on the bottom of the AC adapter.

IMPORTANT NOTICE

Owner's Record

The model and serial numbers are located at the side and/or rear of the TV. Record these numbers in the spaces provided below. Refer to them whenever you call upon your Sony dealer regarding this TV.

Model Name

Serial No.

IMPORTANT NOTICE TO MEXICO

This equipment operation is subject to the following two conditions: (1) It is possible that this equipment or device may not cause harmful interference, and (2) this equipment or device must accept any interference, including interference that may cause undesired operation.

For information related to certificate number, refer to the package label and/or product.

CAUTION

To prevent electric shock and blade exposure, do not use this AC plug with an extension cord, receptacle or other outlet unless the blades can be fully inserted.

- Operate the TV only on 110 V - 240 V AC (except models with supplied AC adapter).
- Operate the TV only on DC 24 V (with AC adapter) (XBR-65X900E only).
- Operate the TV only on DC 19.5 V (with AC adapter) (XBR-55X900E only).

Note

This television includes a QAM demodulator which should allow you to receive unscrambled digital cable television programming via subscription service to a cable service provider. Availability of digital cable television programming in your area depends on the type of programming and signal provided by your cable service provider.

Safety information

WARNING

Never place a television set in an unstable location. A television set may fall, causing serious personal injury or death. Many injuries, particularly to children, can be avoided by taking simple precautions such as:

- Using cabinets or stands recommended by the manufacturer of the television set.
- Only using furniture that can safely support the television set.
- Ensuring the television set is not overhanging the edge of the supporting furniture.
- Not placing the television set on tall furniture (for example, cupboards or bookcases) without anchoring both the furniture and the television set to a suitable support.
- Not placing the television set on cloth or other materials that may be located between the television set and supporting furniture.
- Educating children about the dangers of climbing on furniture to reach the television set or its controls.

If your existing television set is being retained and relocated, the same considerations as above should be applied.

NOTE ON AC ADAPTER (models with supplied AC adapter only)

Warning

To reduce the risk of fire or electric shock, do not expose this apparatus to rain or moisture.

To prevent fire or shock hazard, do not place objects filled with liquids, such as vases, on the apparatus. Do not install this equipment in a confined space, such as a bookshelf or similar unit.

- Please ensure that the AC power outlet is installed near the equipment and shall be easily accessible.
- Be sure to use the supplied AC adapter and AC power cord. Otherwise it may cause a malfunction.
- Connect the AC adapter to an easily accessible AC power outlet.
- Do not coil the AC power cord around the AC adapter. The core wire may be cut and/or it may cause a malfunction of the TV.



- Do not touch the AC adapter with wet hands.
- If you notice an abnormality in the AC adapter, disconnect it from the AC power outlet immediately.
- The set is not disconnected from the AC source as long as it is connected to the AC power outlet, even if the set itself has been turned off.
- As the AC adapter will become warm when it is used for a long time, you may feel hot when touching it by hand.

Before setting up your TV

Some TV models are packaged with a detached Table-Top Stand so you can mount your TV to a wall right away. See page 13 (Installing the TV to the Wall) if you want to mount the TV to a wall. If you are not mounting the TV to a wall, you will need to attach the Table-Top Stand. You will need a Phillips screwdriver (not supplied) and the supplied screws to complete the task. Look for the Setup Guide.

Be sure to consider the following while setting up your TV:

- Disconnect all cables when carrying the TV.
- Carry the TV with the adequate number of people; larger size TVs require two or more people.
- Correct hand placement while carrying the TV is very important for safety and to avoid damage.

XBR-75/65/55X900E

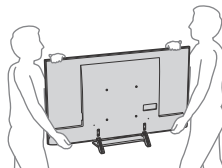

XBR-75/65X850E

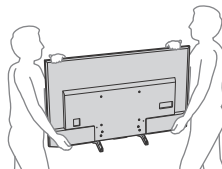

- Ensure your TV has adequate ventilation, see page 16.
- For best picture quality, do not expose the screen to direct illumination or sunlight.
- Avoid installing the TV in a room with reflective wall and floor materials.
- Avoid moving the TV from a cold area to a warm area. Sudden room temperature changes may cause moisture condensation. This may cause the TV to show poor picture and/or poor color. Should this occur, allow moisture to evaporate completely before powering the TV on.

Securing the TV



Sony strongly recommends taking measures to prevent the TV from toppling over. Unsecured TVs may topple and result in property damage, serious bodily injury or even death.

Preventing the TV from Toppling

- Secure the TV to a wall and/or Stand.
- Do not allow children to play or climb on furniture and TV sets.
- Avoid placing or hanging items on the TV.
- Never install the TV on:
 - slippery, unstable and/or uneven surfaces.
 - furniture that can easily be used as steps, such as a chest of drawers.
- Install the TV where it cannot be pulled, pushed, or knocked over.

- Install the TV so that the TV's Table-Top Stand does not protrude out from the Stand (not supplied). If the Table-Top Stand protrudes out from the Stand, it may cause TV set to topple over, fall down, and cause personal injury or damage to the TV.

XBR-75/65/55X900E

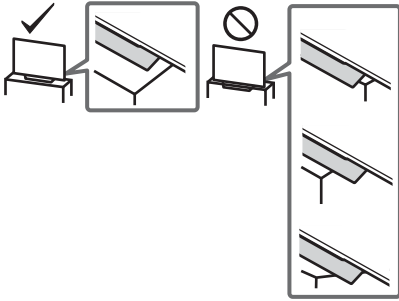

XBR-75/65X850E

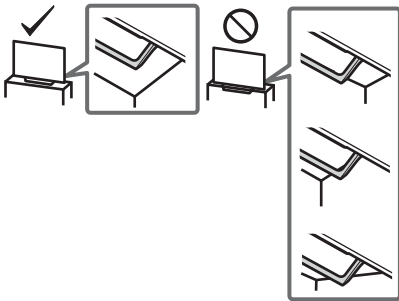

- Route all AC power cords and connecting cables so that they are not accessible to curious children.

Recommended Measures to Secure the TV

Consider the following measures when securing your TV to a Stand (not supplied).

1 Secure the Stand for the TV.

Make sure the Stand can adequately support the weight of the TV. Use two angle braces (not supplied) to secure the Stand. For each angle brace use the appropriate hardware to:

- Attach one side of the angle brace to the wall stud.
- Attach the other side to the Stand.

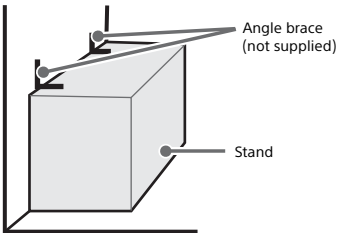

2 Secure the TV to the Stand.

Use the optional hardware listed as follows (not supplied):

- M6 machine screws (screwed into the TV's rear cover).
- A screw or similar (attach it to the Stand).
- Rope or chain (strong enough to support the weight of the TV). Make sure that there is no excess slack in the rope or chain.

XBR-75/65/55X900E

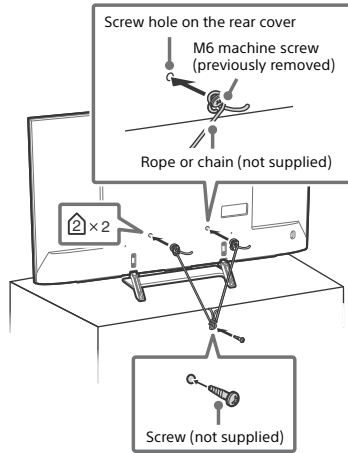
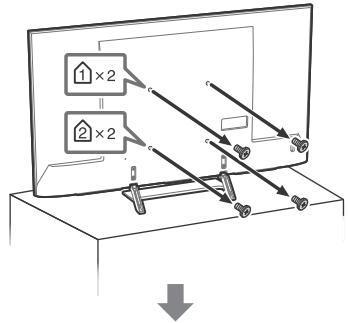

XBR-75X850E

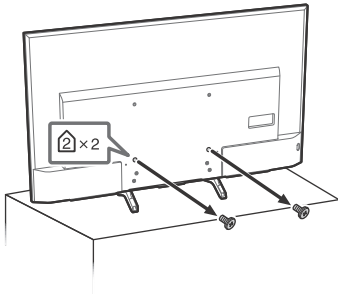

XBR-65X850E

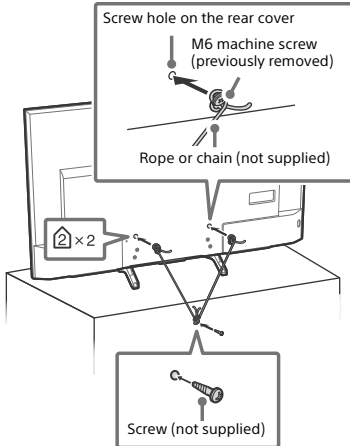
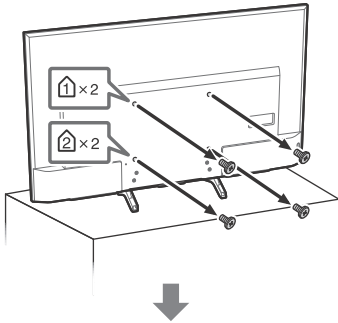

The length of the M6 machine screw differs depending on the rope or chain diameter. Please see below illustration.

8 mm - 12 mm

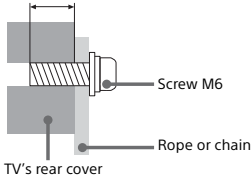

3 Anchor the TV to the wall by using bolts, wall anchor and chain (or rope).

XBR-75/65/55X900E

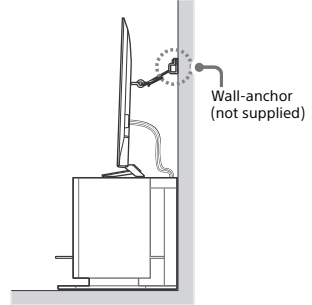
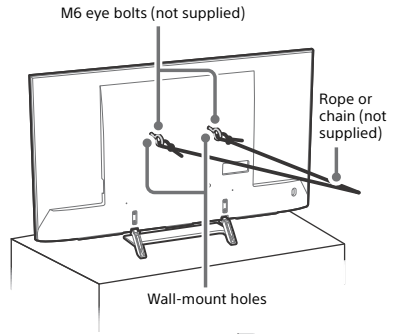

XBR-75/65X850E

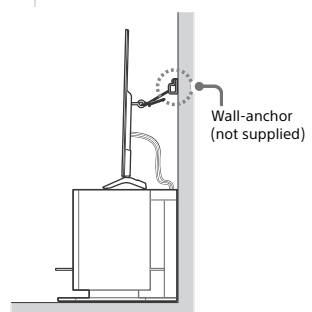
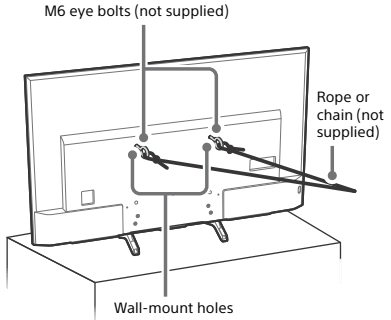

Please see below illustration for M6 eye bolt length.

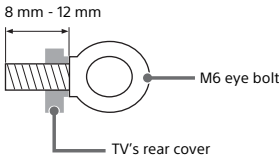

Note

- Your TV is shipped with screws attached to the rear of the TV depending on the TV model. (They are fastened in the screw holes for wall mounting.) Be sure to remove the upper two screws prior to anchoring the TV to a wall.
- Securing the TV to the Stand without securing the TV and the Stand to the wall provides minimum protection against the TV toppling over. For further protection, be sure to follow the three measures recommended.

Precautions

How to care for your BRAVIA TV

Safety is very important. Please read and follow the safety documentation (Safety Booklet) separately provided.

Unplug the TV and other connected equipment from the wall outlet before you begin cleaning your TV.

- Wipe the LCD screen gently with a soft cloth.
- Stubborn stains may be removed with a cloth slightly moistened with a solution of mild soap and warm water.
- If using a chemically pretreated cloth, please follow the instruction provided on the package.
- Never spray water or detergent directly on the TV set. It may drip to the bottom of the screen or exterior parts and enter the TV set, and may cause damage to the TV set.
- Never use strong solvents such as a thinner, alcohol or benzene for cleaning.
- Do not plug in the TV into the wall outlet until the moisture from cleaning has evaporated.
- Do not touch the TV if your hand is covered in any chemical substance such as hand cream or sunblock.

The TV should also be placed on a stable surface to prevent it from toppling over (see page 3). If you have young children or pets at home, check regularly to ensure the TV is securely fastened.



Recommendation for an F type plug

Projection of the inner wire from the connection part must be less than 1.5 mm.

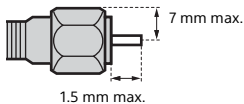

(Reference drawing for an F type plug)

The BRAVIA® 4K TV Experience

Thank you for choosing Sony! Your new BRAVIA® TV opens the door to the "4K TV Experience." This document will help you get the most out of your TV. Please take a moment to register your TV at: <http://esupport.sony.com/LA/perl/registration.pl>

Four Steps to a 4K TV Experience

Set, Source, Sound, and Setup.

1 Set

Now that you have made the best selection in LED backlit LCD TV technology, be sure to remove all of the accessories from the packaging before setting up your TV.

2 Source

To experience the stunning detail of your BRAVIA TV, you need access to HD programming.

- Upgrade your signal or content source to high-definition (HD) by contacting your HD service provider.

This TV displays all video input signals in a resolution of 3,840 dots x 2,160 lines.

- Receive over-the-air HD broadcasts with an HD-quality antenna connected directly to the back of your TV. Visit <http://www.antennaweb.org> for more information on antenna selection and setup.
- Discover the wealth of entertainment now available on super-high resolution Blu-ray Disc™ player and other Sony HD equipment.





3 Sound

Complete the high-definition experience with a BRAVIA Sync™ surround sound system or A/V receiver from Sony.

4 Setup

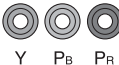
Install your TV and connect your sources. See page 11 for sample connection diagrams. To help assure the highest quality for your HD experience, use Sony HDMI (High-Definition Multimedia Interface) cables.

The following chart shows the high-definition (HD) and standard-definition (SD) video formats supported by your BRAVIA TV inputs.

	INPUT	VIDEO	AUDIO	SUPPORTED FORMATS									
				4K*1	1080/24p/30p	1080p*1	1080i	720/24p/30p	720p*1	480p	480i	PC*2	
4K / HD	HDMI			✓	✓	✓	✓	✓	✓	✓	✓	✓	✓
	COMPONENT	 Y Pb Pr	 Audio L/R			✓	✓		✓	✓	✓		
SD	VIDEO	 Composite video connection	 Audio L/R									✓	

*1 For details of supported formats, refer to the "Specifications" in this manual.

*2 For supported PC formats refer to the Help Guide.

Parts and Controls

Controls and Indicators

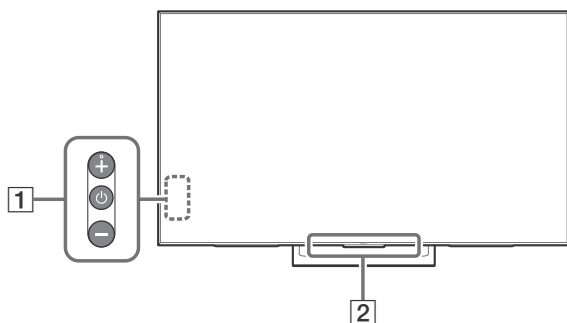



1 (Power) /+/-

When the TV is off,

Press  to power on.

When the TV is on,

Press and hold  to power off.

Press  repeatedly to change the

function, then press + or - button to:

- Adjust the volume.
- Select the channel.
- Select the input source of TV.

2 **Remote Control sensor* / Light sensor* / Illumination LED**

The illumination LED lights up or blinks according to the status of the TV.

For more information, refer to the Help Guide.

* Do not place anything near the sensor.

Using Remote Control

Remote Control Parts Description

The remote control shape, location, availability and function of remote control button may vary depending on your region/country/TV model.

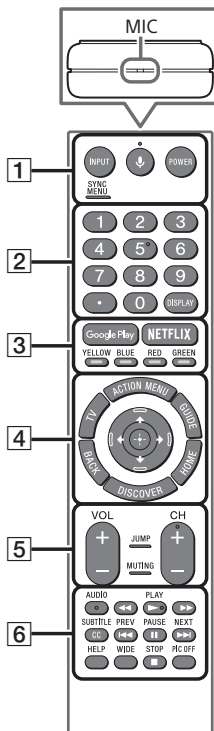

1 INPUT

Display and select the input source.

(Microphone)

Use Voice Function. (e.g., Search various content by voice.)

POWER

Turn on or turn off the TV (standby mode).

SYNC MENU

Display the BRAVIA Sync Menu.

2 Number buttons



Use with the 0-9 buttons to select digital channels.

DISPLAY

Display information about the channel/program/input you are viewing.

3 Google Play

Access the "Google Play" online service.

NETFLIX (Only on limited region/country/TV model)

Access the "NETFLIX" online service.

Color buttons

Execute corresponding function at that time.

4 ACTION MENU

Display a list of contextual functions.

TV

- Switch to a TV channel or input from other applications.
- Turn on the TV to display TV channel or input.

GUIDE

Display the digital program guide.

BACK

Return to previous screen.

HOME

Display the TV Home Menu.

DISCOVER

Bring up the Content Bar to search for content.

▲/▼/◀/▶/⊕ (Item select/Enter)

5 VOL +/- (Volume)

Adjust the volume.

JUMP

Jump back and forth between two channels or inputs. The TV alternates between the current channel or input and the last channel or input that was selected.

MUTING

Mute the sound. Press again to restore the sound.

CH +/- (Channel)

Select the channel.

6 AUDIO

Change the language for the program currently being viewed.



Operate media contents on TV and connected BRAVIA Sync-compatible device.

SUBTITLE/CC

Turn subtitles on or off (when the feature is available).

HELP

Display Help menu. Help Guide can be accessed from here.

WIDE

Change the screen format.

PIC OFF

Turn the picture off, while sound remains on.

Guidelines for IR Remote Control

- Point your remote control directly at the IR sensor located on your TV.
- Make sure that no objects are blocking the path between the remote control and the IR sensor on your TV.

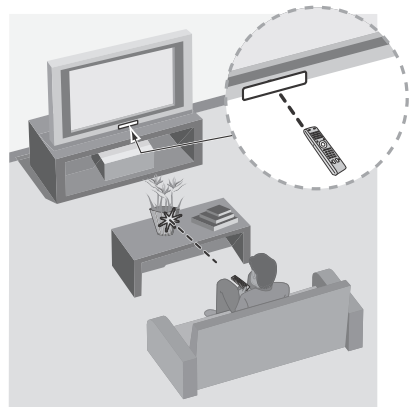

- Fluorescent lamps can interfere with your remote control; try turning off the fluorescent lamps.
- If you are having problems with the remote control, reinsert or replace your batteries and make sure that they are correctly inserted.

IR Blaster Setup

- Follow the on-screen instructions to perform IR Blaster setup during initial setup.
- To perform IR Blaster setup later, press the **HOME** button, then select [Settings] → [External inputs] → [IR Blaster setup].

Connection Diagram

For more information on connections, refer to the Help Guide by pressing **HELP** on the remote control.

Note

- When connecting the cable to the Cable/Antenna input, finger tighten only, over tightening the connection can damage the TV.

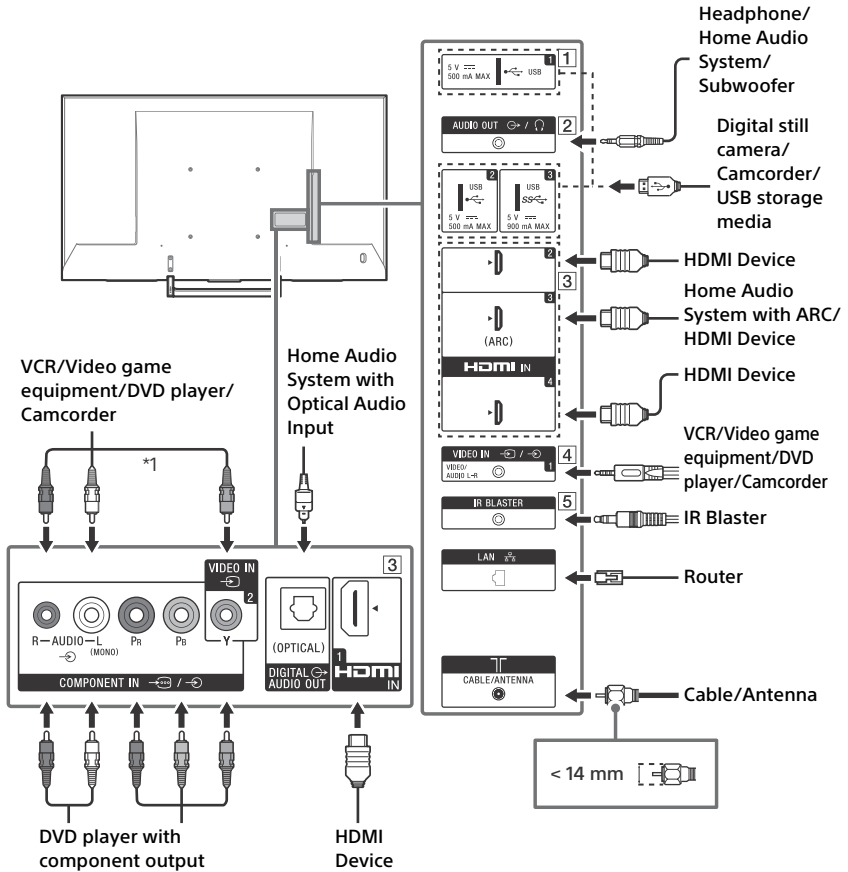

1 **USB 1/2, *SS* USB 3**

- Connecting a large USB device may interfere with other connected devices beside it.
- When connecting a large USB device, connect to the USB 1 port.

2 **AUDIO OUT**

- Supports 3-pole stereo mini jack only.
- To listen to the TV's sound through the connected equipment, press **HOME**. Select [Settings] → [Sound] → [Headphone/Audio out] and then select the desired item.

3 **HDMI IN 1/2/3/4**

- If connecting a digital audio system that is compatible with Audio Return Channel (ARC) technology, use HDMI IN 3. If not, an additional connection with DIGITAL AUDIO OUT (OPTICAL) is necessary.

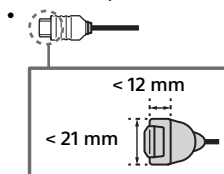

4 **VIDEO IN 1**

- For a composite connection, use an Analog Extension Cable (not supplied).

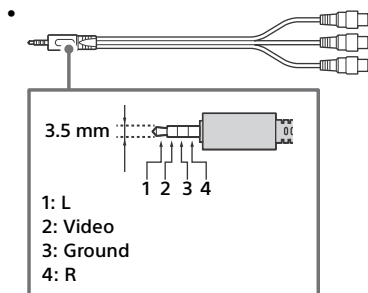

5 **IR BLASTER*2**

*1 When connecting mono equipment, connect to the L (MONO) audio jack (socket).

*2 Only on limited region/country/TV model.

Installing the TV to the Wall

This TV's instruction manual only shows the steps on preparing the installation of the TV before installing to the wall.

Your TV can be mounted on a wall using a Wall-Mount Bracket (not supplied) out of the box as packaged. If the Table-Top Stand is attached to the TV, the TV may require detaching the Table-Top Stand; see page 15 (Detaching the Table-Top Stand from the TV).

Prepare the TV for the Wall-Mount Bracket before making cable connections.

For product protection and safety reasons, Sony strongly recommends that installation of your TV on the wall be performed by qualified professionals. Do not attempt to install it yourself.

- Follow the instruction guide provided with the Wall-Mount Bracket for your model. Sufficient expertise is required in installing this TV, especially to determine the strength of the wall for withstanding the TV's weight.
- The length of the screw for Wall-Mount Bracket differs depending on the Wall-Mount Bracket thickness. Please see below illustration.

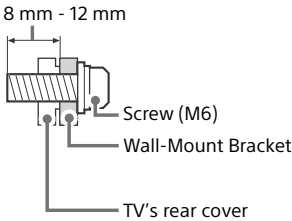

- Be sure to store the unused screws and Table-Top Stand in a safe place until you are ready to attach the Table-Top Stand. Keep the screws away from small children.

Note

- Read the supplied Safety Booklet for additional safety information.

1 Removing the screws from the rear of the TV

XBR-75/65/55X900E

XBR-75X850E

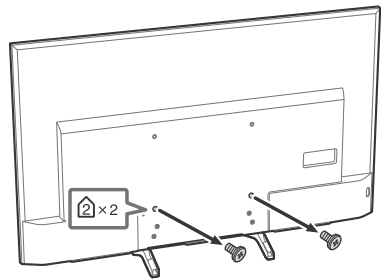
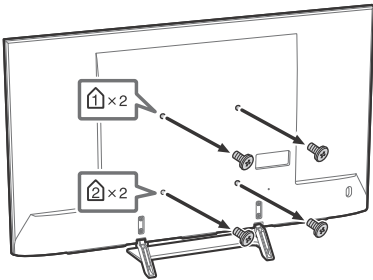

XBR-65X850E

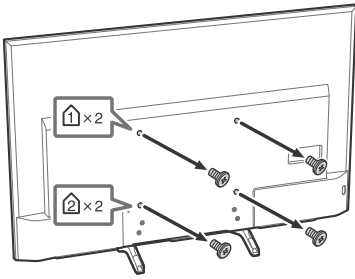

2 Attach the Wall-Mount Bracket (not supplied) using the screws (not supplied).

XBR-75/65/55X900E

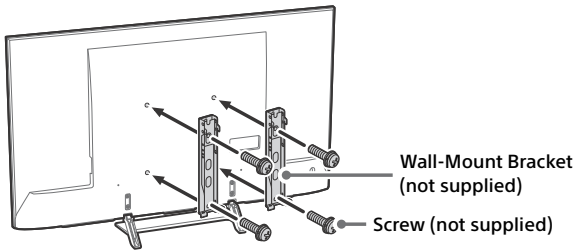

XBR-75/65X850E

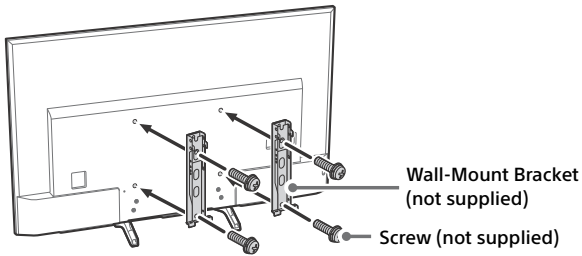

Note

- If using an electric screwdriver, set the torque at approximately 1.5 N·m {15 kgf·cm}.

Detaching the Table-Top Stand from the TV

To detach the Table-Top Stand from the TV, remove the screws .

XBR-75/65/55X900E

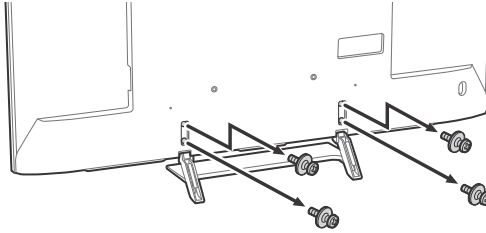

XBR-75/65X850E

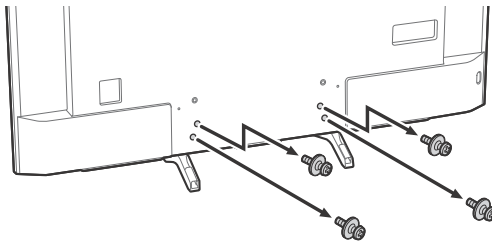

Note

- Do not remove the Table-Top Stand for any reason other than to install corresponding accessories on the TV.
- Be sure the TV is vertical before turning on. To avoid uneven picture uniformity do not power on the TV with the LCD panel facing down.
- When attaching the Table-Top Stand again, be sure to fasten the screws (previously removed) to the original holes on the rear of the TV.

Installing the TV against a wall or enclosed area

Ventilation

- Never cover the ventilation holes or insert anything in the cabinet.
- Leave space around the TV set as shown below.

Installed with stand

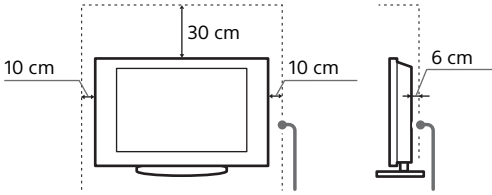

Leave at least this much space around the set.

Installed on the wall

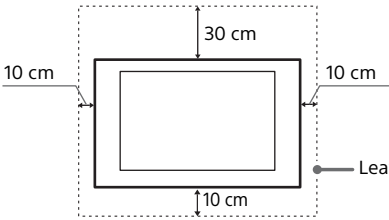

Leave at least this much space around the set.

Never install the TV set as follows:

Air circulation is blocked. Air circulation is blocked.

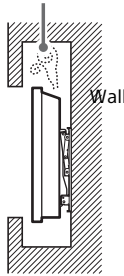
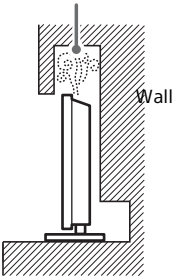

Note

- Inadequate ventilation can lead to overheating of the TV and may cause damage to your TV or cause a fire.

Troubleshooting

General troubleshooting for issues like: black screen, no sound, frozen picture, TV does not respond, or network is lost, do the following steps.

- 1 Restart your TV by pressing the power button on the remote control until a message appears. The TV will restart. If the TV does not recover, try unplugging the TV from the AC power cord for two minutes and then plug it in again.
- 2 Refer to the Help menu by pressing **HELP** on the remote control.
- 3 Connect your TV to the Internet and perform a software update.
- 4 Visit Sony support website (information provided on the front cover).
- 5 Perform the factory data reset. Refer to "How to reset the TV to factory settings" (page 17).

When [A new TV system software update is available...] message is displayed.

Sony strongly recommends you to update the TV software by selecting [Update Now]. These software updates improve your TV performance or add new features. The following screen with [Updating...] will appear and the illumination LED flashes white while software is updating.

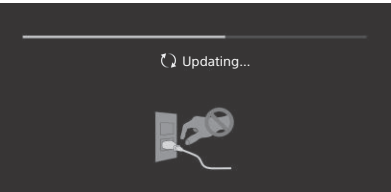

Do not unplug the AC power cord during the software update. If you do, the software update may not finish completely, and it may cause a software malfunction. Software updates can take up to 15 minutes.

When you plug in TV, the TV may not be able to turn on for a while even if you press the power button on the remote control or the TV.

It takes time to initialize the system. Wait for about one minute, then operate it again.

How to reset the TV to factory settings

WARNING: The reset will clear all of your customized settings including the parental lock setting.

- Turn on the TV. You can reset the TV to factory settings by pressing **HOME**, then select [Settings] → [Storage & reset] → [Factory data reset].
- To force factory data reset, unplug the AC power cord. Press and hold both \odot and $-$ buttons on the TV, then plug in the AC power cord. Release both buttons when the illumination LED blinks in green.
- For security purposes, be sure to remove all personal and account information before discarding, selling or passing your TV to someone else by: unlinking/unregistering, signing out of and deactivating all network services as well as factory reset the TV.

Troubles and Solutions

When the illumination LED is flashing in red.

- Count how many times it flashes (interval time is three seconds).
Reboot the TV by disconnecting the AC power cord from the TV for two minutes, then turn on the TV.
If the problem persists, disconnect the AC power cord, and contact Sony Customer Support (information provided on the front cover) with the number of times the illumination LED flashes.

There is no picture (screen is dark) and no sound.

- Check the cable/antenna connection.
- Connect the TV to AC power, and press the \odot button on the TV or **POWER** button on the remote control.

Some programs cannot be tuned.

- Check the cable/antenna connection.

The remote control does not function.

- Replace the batteries.

The parental lock password has been forgotten.

- Enter 4357 for the password and select [Change PIN].

The restricted profile password has been forgotten.

- Perform the force factory data reset. Refer to "How to reset the TV to factory settings" (page 17).

The TV and its surroundings become warm.

- When the TV is used for an extended period of time, the TV and its surroundings may become warm to the touch. This is not a malfunction of the TV.

Specifications

System

Television system

NTSC: American TV standard

ATSC (8VSB terrestrial): ATSC compliant 8VSB

QAM on cable: ANSI/SCTE 07 2000 (Does not include CableCARD functionality)

Channel coverage

Analog terrestrial: 2 - 69 / Digital terrestrial: 2 - 69

Analog Cable: 1 - 135 / Digital Cable: 1 - 135

Panel system

LCD (Liquid Crystal Display) Panel, LED Backlight

Speaker output

10 W + 10 W

Wireless technology

Protocol IEEE802.11ac/a/b/g/n

Bluetooth Version 4.1

Input/Output jacks

CABLE/ANTENNA

75-ohm external terminal for RF inputs

 /  VIDEO IN 1

Video/Audio input (mini jack)

 /  COMPONENT IN

YPbPr (Component Video): 1080p (60 Hz),

1080i (60 Hz), 720p (60 Hz), 480p, 480i

Audio input (phono pin jack)

 VIDEO IN 2

Video input (common phono pin with Y input)

HDMI IN 1/2/3/4 (Support 4K resolution, HDCP 2.2-compatible)

Video:

4096 × 2160p (60 Hz)^{*1*}, 4096 × 2160p

(24 Hz)^{*1}, 3840 × 2160p (60 Hz)^{*2},

3840 × 2160p (24, 30 Hz), 1080p (30, 60 Hz),

1080/24p, 1080i (60 Hz), 720p (30, 60 Hz),

720/24p, 480p, 480i, PC Formats^{*3}

^{*1} When 4096 × 2160p is input and [Wide mode] is set to [Normal], the resolution is displayed as 3840 × 2160p. To display 4096 × 2160p, set [Wide mode] setting to [Full 1] or [Full 2].

^{*2} HDMI IN 2 / 3 only.

^{*3} Refer to the Help Guide for details.

Audio: 5.1 channel linear PCM: 32, 44.1, 48, 88.2, 96, 176.4 and 192 kHz, 16, 20 and 24 bits, Dolby Digital, Dolby Digital Plus and DTS

ARC (Audio Return Channel) (HDMI IN 3 only)

(Two channel linear PCM: 48 kHz, 16 bits, Dolby Digital, Dolby Digital Plus, DTS)

🔊 DIGITAL AUDIO OUT (OPTICAL)

Digital optical jack (Two channel linear PCM: 48 kHz, 16 bits, Dolby Digital, DTS)

AUDIO OUT 🎧 / 🔊 (Stereo mini jack)

Headphone, Audio output, Subwoofer

🔌 1, 🔌 2, 🚀 3

USB port 1 and 2 support High Speed USB (USB2.0).

USB port 3 supports Super Speed USB (USB3.0).

🌐 LAN

10BASE-T/100BASE-TX connector
(Connection speed may differ depending on the network environment. 10BASE-T/100BASE-TX communication rate and communication quality are not guaranteed for this TV.)

Home Network

Refer to the Help Guide for supported formats.

⊖ ⊕ DC IN 24 V (XBR-65X900E only)

AC adapter input (24 V DC)

⊖ ⊕ DC IN 19.5 V (XBR-55X900E only)

AC adapter input (19.5 V DC)

IR BLASTER

IR Blaster Cable input (mini jack)

Others

Receptor IR (infrarrojo) con cable

AC adapter*1

ACDP-240E02 (XBR-65X900E only)

ACDP-200D02 (XBR-55X900E only)

Operating temperature

0 °C – 40 °C

Power and others

Power requirement

except models with supplied AC adapter

110 V - 240 V AC, 50/60 Hz

models with supplied AC adapter only

24 V DC with AC adapter (XBR-65X900E)

19.5 V DC with AC adapter (XBR-55X900E)

AC adapter electrical ratings*1

Model: ACDP-240E02

Input: 100 V - 240 V AC, 50/60 Hz, 2.6 A

Output: DC 24 V, 10 A

Model: ACDP-200D02

Input: 100 V - 240 V AC, 50/60 Hz, 2.5 A

Output: DC 19.5 V, 10.26 A

Power consumption

in use

XBR-75X900E: 310 W

XBR-75X850E: 219 W

XBR-65X900E: 212 W

XBR-65X850E: 174 W

XBR-55X900E: 171 W

in standby*2*3

Less than 0.50 W with 120 V AC and less than

0.50 W with 240 V AC

Screen size (measured diagonally) (Approx.)

XBR-75X900E: 189.3 cm / 74.5 inches

(75" class)

XBR-75X850E: 189.3 cm / 74.5 inches

(75" class)

XBR-65X900E: 163.9 cm / 64.5 inches

(65" class)

XBR-65X850E: 163.9 cm / 64.5 inches

(65" class)

XBR-55X900E: 138.8 cm / 54.6 inches

(55" class)

Display resolution

3,840 dots (horizontal) × 2,160 lines (vertical)

Output Rating

USB 1/2

5 V, —, 500 mA MAX

USB 3

5 V, —, 900 mA MAX

*1 Refiérase al adaptador ca/cc suministrado.

*2 Specified standby power is reached after the TV finishes necessary internal processes.

*3 Standby power consumption will increase when your TV is connected to the network.

Dimensions (Approx.)

with stand

XBR-75X900E: 1,674 × 1,021 × 296 mm

XBR-75X850E: 1,677 × 1,032 × 284 mm

XBR-65X900E: 1,447 × 895 × 259 mm

XBR-65X850E: 1,454 × 905 × 266 mm

XBR-55X900E: 1,228 × 772 × 259 mm

without stand

XBR-75X900E: 1,674 × 959 × 66 mm

XBR-75X850E: 1,677 × 968 × 53 mm

XBR-65X900E: 1,447 × 830 × 60 mm

XBR-65X850E: 1,454 × 840 × 44 mm

XBR-55X900E: 1,228 × 707 × 60 mm

wall-mount hole pattern

XBR-75X900E: 400 × 400 mm

XBR-75X850E: 400 × 300 mm

XBR-65X900E: 300 × 300 mm

XBR-65X850E: 300 × 300 mm

XBR-55X900E: 300 × 300 mm

wall-mount screw size (mm)

M6 (length: see diagram on page 13.)

Mass (Approx.)

with stand

XBR-75X900E: 35 kg

XBR-75X850E: 35.2 kg

XBR-65X900E: 23.2 kg

XBR-65X850E: 22.1 kg

XBR-55X900E: 18.1 kg

without stand

XBR-75X900E: 33.2 kg
XBR-75X850E: 34.1 kg
XBR-65X900E: 22 kg
XBR-65X850E: 21 kg
XBR-55X900E: 16.9 kg

Note

- Optional accessories availability depends on countries/region/TV model/stock.
- Design and specifications are subject to change without notice.

Licensing Information

- The terms HDMI and HDMI High-Definition Multimedia Interface, and the HDMI Logo are trademarks or registered trademarks of HDMI Licensing LLC in the United States and other countries.
- Manufactured under license from Dolby Laboratories. Dolby, Dolby Audio, and the double-D symbol are trademarks of Dolby Laboratories.
- "BRAVIA" and BRAVIA, S-Force, Motionflow, BRAVIA Sync, and  are trademarks or registered marks of Sony Corporation.
- Gracenote, Gracenote eyeQ, Gracenote VideoID, Gracenote Video Explore, the Gracenote logo and logotype, and the "Powered by Gracenote" logo are either registered trademarks or trademarks of Gracenote in the United States and/or other countries.
- Opera® Devices SDK. Copyright 1995-2016 Opera TV AS. All rights reserved.
- Wi-Fi, Wi-Fi Direct, Miracast, Wi-Fi Protected Setup and Wi-Fi CERTIFIED Logo are trademarks or registered trademarks of Wi-Fi Alliance.
- For DTS patents, see <http://patents.dts.com>. Manufactured under license from DTS, Inc. DTS, the Symbol, & DTS and the Symbol together are registered trademarks, and DTS Digital Surround is a trademark of DTS, Inc. © DTS, Inc. All Rights Reserved.

- The Bluetooth® word mark and logos are registered trademarks owned by the Bluetooth SIG, Inc. and any use of such marks by Sony Corporation is under license. Other trademarks and trade names are those of their respective owners.
- TUXERA is a registered trademark of Tuxera Inc. in the US and other countries.
- USB-IF SuperSpeed USB Trident logo is a registered trademark of USB Implementers Forum, Inc. 



TUXERA

YOUR DATA - WHERE YOU WANT IT

4K

Resolución real:
3 840 x 2 160 píxeles

For Your Convenience

Online Registration:	Be sure to register your TV. http://esupport.sony.com/LA/perl/registration.pl
Software Updates:	Your TV is capable of receiving software updates. For the latest information about software updates for your TV, visit: http://esupport.sony.com/LA/ NOTE: If your TV is connected to the Internet, you can check for software updates by pressing HELP , and select [System software update].



Help Guide

http://rd1.sony.net/help/tv/eusltn1/h_us/