

STIHL FS 74, FS 76

**Instruction Manual
Owner's Manual**

**Assembling
Safety Precautions
Operating Instructions
Maintenance**

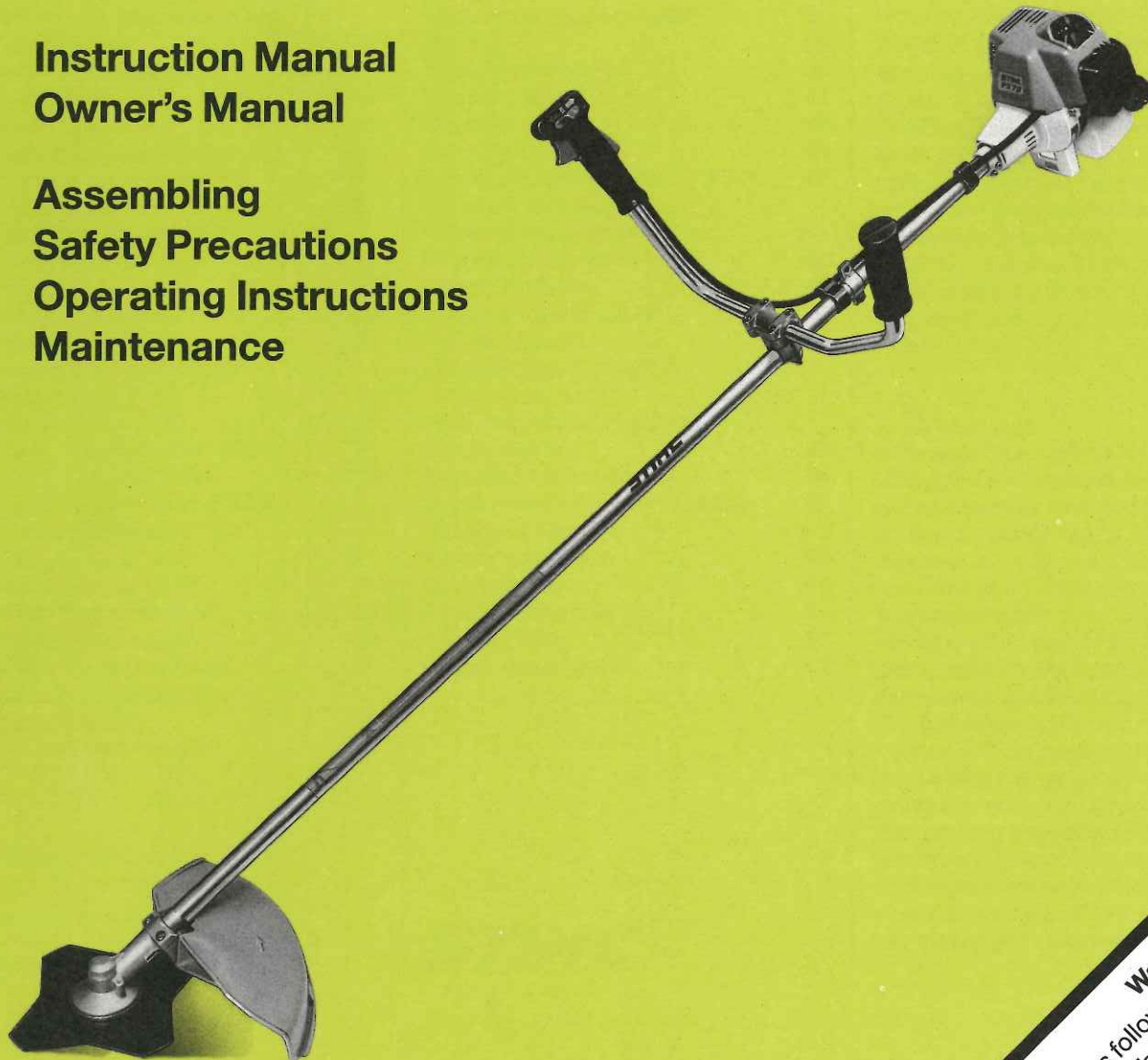

Warning:
Always follow safety precautions in
Owner's Manual - improper use
can cause serious injury!

Contents

Parts and Controls		Fuel	31
- Version with Bike Handle	2	Fueling	33
- Version with Loop Handle	4	Fitting the Harness	33
- Version with Loop Handle and Standoff Lever	4	- Balancing the Brushcutter	34
Safety Precautions and Working Techniques	6	Starting	35
Selecting the Cutting Tool	18	Adjusting Carburetor	39
Mounting the Bike Handle	20	Checking Spark Plug	42
Mounting Loop Handle with Standoff Lever	21	Cleaning Air Filter	42
Mounting the Loop Handle		Gearbox Lubrication	43
- Version A	22	Lubricating Flexible Shaft (FS 74)	43
- Version B	23	Sharpening Cutting Tools	
Mounting the Deflector	23	- Grass Cutting Blade 230-4	44
- Fitting stop	24	- Grass Cutting Blade 230-8	45
Mounting the Cutting Tools		- Brush Knife 250	46
- Preparations	24	- Circular Saw Blade 200 (Chisel Tooth)	47
- Blocking Drive Shaft	25	- Circular Saw Blade 200 (Scratcher Tooth)	48
- STIHL "Supercut 20-1" (FS 74)	26	Replacing Starter Rope and Rewind Spring	49
- STIHL "Supercut 20-2"	26	Operating Instructions	51
- STIHL "Autocut 20-2" (FS 74)	27	Spark Arresting Screen in Muffler	52
- STIHL "Autocut 25-2"	27	Storing the Machine	52
- STIHL "Autocut 30-2"	27	Maintenance Chart	53
- STIHL "Autocut 24-2"	28	Specifications	54
- STIHL "Polymatic 30-2"	28	Special Accessories	
- STIHL "Polycut 20-3"	28	- Cutting Tools	56
- STIHL "Fixed Line Head"	29	- Other Accessories	56
- Grass Cutting Blade 230	30		
- Brush Knife 250	30		
- Circular Saw Blade 200	30		

Printed on chlorine-free paper

© 1997 Andreas Stihl, Waiblingen

0458 356 3021. M0,35. G7. DI. Printed in Germany

x

STIHL[®]

This manual contains warnings, operating and safety precautions for the STIHL FS 74 and FS 76 brushcutters. Pay special attention to the safety precautions outlined on pages 6 to 17. Allow only persons who understand this manual to operate your brushcutter. To receive maximum performance and satisfaction from your STIHL brushcutter, it is important that you read and understand the maintenance and safety precautions before using your brushcutter. Contact your STIHL dealer or the STIHL distributor for your area if you do not understand any of the instructions in this manual.



Warning!

Because a brushcutter is a high-speed cutting tool some special safety precautions must be observed to reduce the risk of personal injury. Careless or improper use may cause serious or even fatal injury. Make sure your unit is equipped with the proper deflector, handle and harness for the type of cutting attachment being used. Always wear proper eye protection. STIHL's philosophy is to continually improve all of its products. As a result, engineering changes and improvements are made from time to time. If the operating characteristics or the appearance of your brushcutter differs from those described in this manual, please contact your STIHL dealer for information and assistance.

Parts and Controls

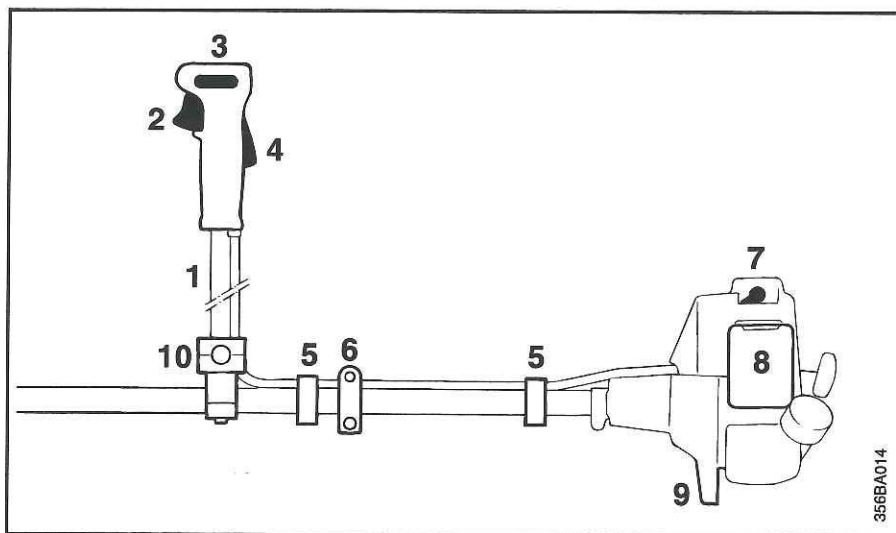

Version with bike handle

- 1 = Bike handle
- 2 = Throttle trigger
- 3 = Slide control
- 4 = Throttle trigger interlock
- 5 = Hose tie (FS 74),
throttle cable retainer (FS 76)
- 6 = Carrying ring
- 7 = Spark plug boot
- 8 = Air filter cover
- 9 = Machine support
- 10 = Handle support

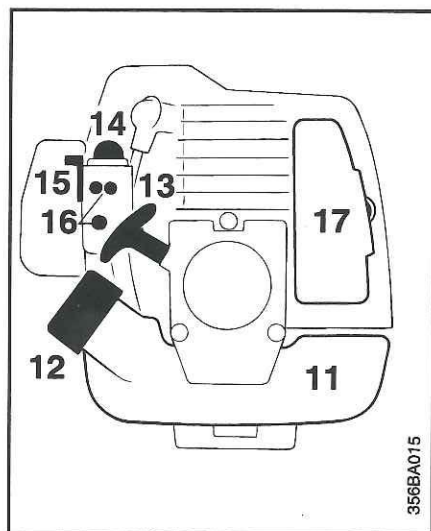

- 11 = Fuel tank
- 12 = Fuel filler cap
- 13 = Starter grip
- 14 = Fuel pump
- 15 = Choke lever
- 16 = Carburetor adjusting screws
- 17 = Muffler

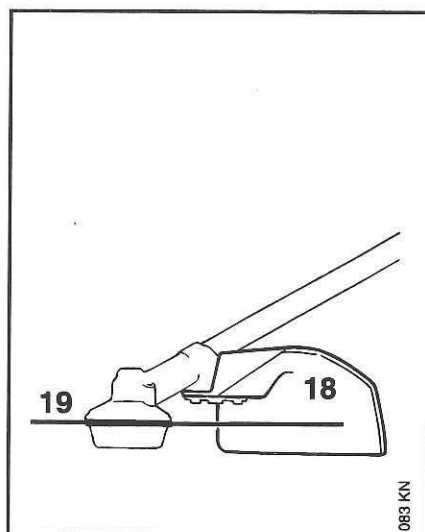

- 18 = Deflector
- 19 = Cutting tool

Definitions

1. **Bike handle.**
To hold the brushcutter with both hands.
2. **Throttle trigger.**
Controls the speed of the engine.
3. **Slide control.**
Starting throttle lock and stop switch.
Keeps the throttle partially open during starting and switches the engine's ignition off and stops the engine.
4. **Throttle trigger interlock.**
Must be depressed before the throttle trigger can be activated.
5. **Hose tie (FS 74),
throttle cable retainer (FS 76)**
Fixes the throttle cable on the drive shaft.
6. **Carrying ring.**
The device to connect the brushcutter to the harness.
7. **Spark plug boot.**
Connects the spark plug to the ignition wire.
8. **Air filter cover.**
Covers the air filter element.
9. **Machine support.**
For resting machine on the ground.
10. **Handle support.**
Connects the drive shaft to the handle bars.
11. **Fuel tank.**
For fuel and oil mixture.
12. **Fuel filler cap.**
For closing the fuel tank.
13. **Starter grip.**
The grip of the pull starter, which is the device to start the engine.
14. **Fuel pump.**
Provides additional fuel feed for a cold start.
15. **Choke lever.**
Eases engine starting by enriching mixture.
16. **Carburetor adjusting screws.**
For tuning carburetor
17. **Muffler.**
Attenuates exhaust noises and diverts exhaust gases away from operator.
18. **Deflector.**
The deflector is designed to reduce the risk of injury from foreign objects flung backwards toward the operator by the cutting tool and from contact with the cutting tool.
19. **Cutting tool.**
The cutting attachment, i. e. blade, made from metal for different purposes (special accessory).

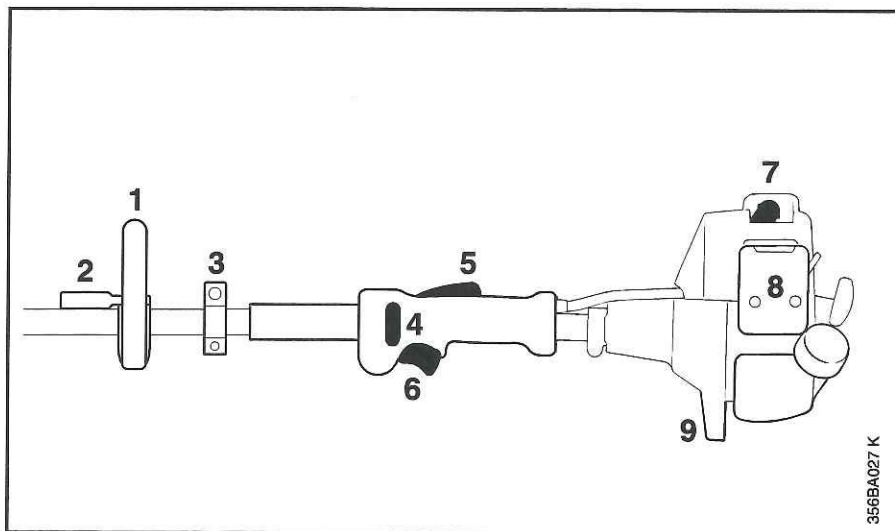

356BA027 K

Version with loop handle and loop handle with standoff lever

- 1 = Loop handle
- 2 = Standoff lever
- 3 = Carrying ring
- 4 = Slide control
- 5 = Throttle trigger interlock
- 6 = Throttle trigger
- 7 = Spark plug boot
- 8 = Air filter cover
- 9 = Machine support

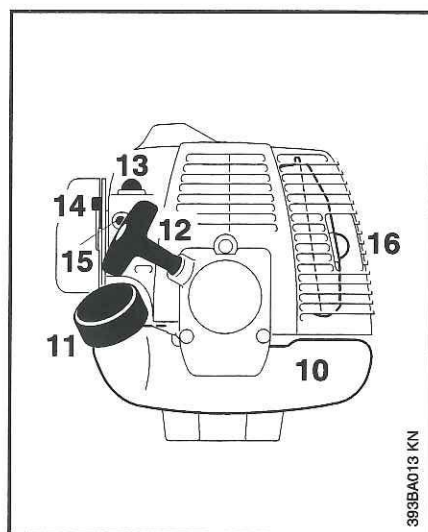

393BA013 KN

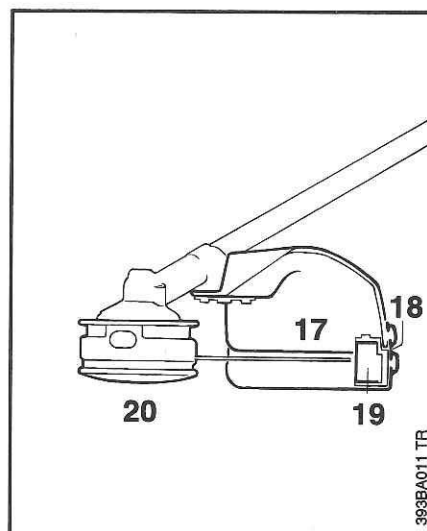

393BA011 TR

- 10 = Fuel tank
- 11 = Fuel filler cap
- 12 = Starter grip
- 13 = Fuel pump
- 14 = Choke lever
- 15 = Carburetor adjusting screws
- 16 = Muffler
- 17 = Deflector
- 18 = Skirt
- 19 = Blade
- 20 = Cutting tool

Definitions

1. **Loop handle.**
For easy control of machine during cutting work.
2. **Standoff lever.**
Helps keep unit at a safe distance from operator's feet and legs.
3. **Carrying ring.**
The device to connect the brushcutter to the harness.
4. **Slide control.**
Starting throttle lock and stop switch.
Keeps the throttle partially open during starting and switches the engine's ignition off and stops the engine.
5. **Throttle trigger interlock.**
Must be depressed before the throttle trigger can be activated.
6. **Throttle trigger.**
Controls the speed of the engine.
7. **Spark plug boot.**
Connects the spark plug to the ignition wire.
8. **Air filter cover.**
Covers the air filter element.
9. **Machine support.**
For resting machine on the ground.
10. **Fuel tank.**
For fuel and oil mixture.
11. **Fuel filler cap.**
For closing the fuel tank.
12. **Starter grip.**
The grip of the pull starter, which is the device to start the engine.
13. **Fuel pump.**
Provides additional fuel feed for a cold start.
14. **Choke lever.**
Eases engine starting by enriching mixture.
15. **Carburetor adjusting screws.**
For tuning carburetor
16. **Muffler.**
Attenuates exhaust noises and diverts exhaust gases away from operator.
17. **Deflector with skirt.**
The deflector is designed to reduce the risk of injury from foreign objects flung backwards toward the operator by the cutting tool and from contact with the cutting tool.
18. **Skirt.**
The skirt at the bottom of the deflector must be adjusted as described in the chapters on mounting the various cutting tools.
19. **Blade.**
Metal blade at the deflector in order to keep the line of the mowing head at the proper length.
20. **Cutting tool.**
The cutting attachment, i. e. cutting head, for different purposes (special accessory).

Safety Precautions and Working Techniques



Warning!

Because a brushcutter is a high-speed, fast-cutting power tool, special safety precautions must be observed to reduce the risk of personal injury.



It is important that you read, fully understand and observe the following safety precautions and warnings. Read the owner's manual and the safety instructions periodically. Careless or improper use of any brushcutter may cause serious or fatal injury. Have your STIHL dealer show you how to operate your brushcutter. Observe all applicable local safety regulations, standards and ordinances.



Warning!

The use of any brushcutter may be hazardous. If the rotating cutting tool comes in contact with your body, it will cut you. When it comes in contact with solid foreign objects such as rocks or bits of metal, it may fling them directly or by ricochet in the direction of bystanders or the operator.

Striking such objects could damage the cutting attachment and may cause blades to crack, chip or break.

STIHL does not recommend the use of rigid blades when cutting in stony areas. Thrown objects or damaged blades may result in serious or fatal injury to the operator or bystanders.



Warning!

Minors should never be allowed to use a brushcutter. Bystanders, especially children, and animals should not be allowed in the area where a brushcutter is in use.

Never let the brushcutter run unattended.



Warning!

Do not lend or rent your brushcutter without the owner's manual. Be sure that anyone using your brushcutter understands the information contained in this manual.

Most of these safety precautions and warnings apply to the use of all STIHL brushcutters. Different models may have different parts and controls. See the appropriate section of your owner's manual for a description of the controls and function of the parts of your model brushcutter.

Safe use of a brushcutter involves

1. the operator
2. the brushcutter
3. the use of the brushcutter.

THE OPERATOR!

Physical Condition

You must be in good physical condition and mental health and not under the influence of any substance (drugs, alcohol, etc.) which might impair vision, dexterity or judgment. Do not operate a brushcutter when you are fatigued.

Be alert - if you get tired while operating your brushcutter, take a break. Tiredness may result in loss of control. Working with any brushcutter can be strenuous. If you have any condition that might be aggravated by strenuous work, check with your doctor before operating a brushcutter. Prolonged use of a brushcutter (or other machines) exposing the operator to vibrations may produce whitefinger disease (Raynaud's phenomenon) or carpal tunnel syndrome. These conditions reduce the hand's ability to feel and regulate temperature, produce numbness and burning sensations and may cause nerve and circulation damage and tissue necrosis.



Warning!

Antivibration systems do not guarantee that you will not sustain whitefinger disease or carpal tunnel syndrome. Therefore, continual and regular users should monitor closely the condition of their hands and fingers. If any of the above symptoms appear, seek medical advice immediately.

Proper Clothing



Warning!



Brushcutter operation can cause serious injury to eyes, ears and person. The deflector provided with your brushcutter may not protect the operator from all foreign objects (gravel, glass, wire, etc.) thrown by the rotating cutting attachment. Thrown objects may also ricochet and strike the operator. Therefore, to reduce the risk of injury to your eyes never operate a brushcutter unless wearing goggles or properly fitted safety glasses with adequate top and side protection complying with ANSI Z 87.1 (or your applicable national standard). To reduce the risk of injury to your face STIHL recommends that you also wear a face shield or face screen over your goggles or safety glasses.



Warning!



Brushcutter noise may damage your hearing. Wear sound barriers (ear plugs or ear muffs) to protect your hearing. Continual and regular users should have their hearing checked regularly.

Wear proper protective clothing.



Protect your hands with gloves when handling the brushcutter and the cutting tool. Heavy-duty, nonslip gloves improve your grip and protect your hands.



Clothing must be sturdy and snug-fitting, but allow complete freedom of movement. Avoid loose-fitting jackets, scarfs, neckties, jewelry, flared or cuffed pants, unconfined long hair or anything that could become caught on branches, brush or moving parts of the unit. Wear long pants made of heavy material to protect your legs. Do not wear shorts, pants, sandals or go bare foot. Secure hair so it is above shoulder level.



Good footing is most important in brushcutter work. Wear sturdy boots with nonslip soles. Steel-toed safety boots are recommended.



Wear an approved safety hard hat to reduce the risk of injury to your head when there is a danger of head injuries.

THE BRUSHCUTTER

For illustrations and definitions of the brushcutter parts see the chapter on "Parts and Controls"



Warning!

Never modify a brushcutter in any way. Only attachments supplied by STIHL or expressly approved by STIHL for use with the specific STIHL brushcutter models are authorized. Although certain unauthorized attachments are useable for the STIHL brushcutter, their use may, in fact, be extremely dangerous.

THE USE OF THE BRUSHCUTTER

Transporting the brushcutter



Warning!

Always turn off the engine and make sure the cutting attachment has stopped before putting a brushcutter down. When transporting your brushcutter in a vehicle, properly secure it to prevent turnover, fuel spillage and damage to the brushcutter. Keep metal cutting tools covered with the transport guard (optional accessory).

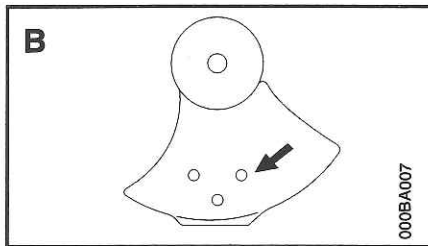
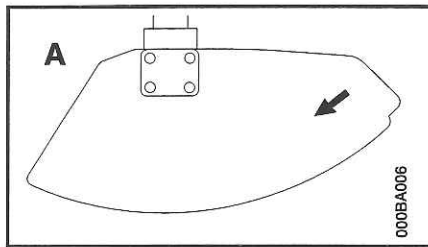

Preparation for the use of the brushcutter

Adjust carrying harness and hand grip to suit your size before starting work. The machine should be properly balanced as specified in your owner's manual for proper control and less fatigue in operation.

Always check your brushcutter for proper condition and operation before starting, particularly the throttle trigger, throttle trigger interlock (if applicable), stop switch, cutting tool, deflector and harness.

Arrows on the deflector (A) and stop (B) show the correct direction of rotation of the cutting tool.

The throttle trigger must move freely and always spring back to the idle position. The cutting tool must be properly tightened and in safe operating condition. Inspect for loose parts (nuts, screws, etc.) and for cracked, bent, warped or damaged blades.

Fueling

Your STIHL brushcutter uses an oil-gasoline mixture for fuel (see the chapter on "Fuel" of your owner's manual).

Warning!



Gasoline is an extremely flammable fuel. If spilled and ignited by a spark or other ignition source, it can cause fire and serious burn injury or property damage. Use extreme caution when handling gasoline or fuel mix.

Do not smoke or bring any fire or flame near the fuel.

Fueling Instructions

Fuel your brushcutter in well-ventilated areas, outdoors.

Warning!

Gasoline vapor pressure may build up inside the gas tank of a two cycle engine depending on the fuel used, the weather conditions, and the venting system of the tank. In order to reduce the risk of burns and other personal injury from escaping gas vapor and fumes, remove the fuel filler cap on your brushcutter carefully so as to allow any pressure build-up in the tank to release slowly. Never remove fuel filler cap while engine is running. Select bare ground for fueling and move at least 10 feet (3 m) from the fueling spot before starting the engine. Wipe off any spilled fuel before starting your brushcutter and check for leakage.

Warning!

Check for fuel leakage while refueling and during operation. If fuel or oil leakage is found, do not start or run the engine until leak is fixed and spilled fuel has been wiped away. If this happens, change your clothing immediately.

Warning!



Unit vibrations can cause an improperly tightened fuel cap to loosen or come off and spill quantities of fuel.

In order to reduce risk of fuel spillage and fire, tighten fuel cap by hand with as much force as possible.

The screwdriver end of the STIHL combination wrench or other similar tool can be used as an aid for tightening slotted fuel caps.

Operating instructions

Warning!

Improper use of any brushcutter can cause serious or fatal personal injury. Read, understand and follow all safety instructions in your owner's manual before operating these products. To reduce the risk of personal injury to the operator from blade contact and thrown objects, make sure your unit is equipped with the proper deflector, handle and harness for the type of cutting attachment being used (see chart in chapter on "Selecting the Cutting Tool"). Always wear proper eye protection.

Starting

Warning!

Your brushcutter is a one-person machine. Once started, it may fling foreign objects for a great distance.

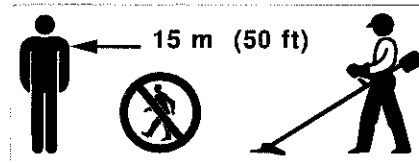

To reduce the risk of eye and other injury insure that bystanders are at least 50 feet (15 m) away. Stop the engine and cutting tool immediately if you are approached. Start and operate your brushcutter without assistance. For specific starting instructions, see the appropriate section of your manual. Place the brushcutter on firm ground or other solid surface in an open area. Maintain a good balance and secure footing.

Warning!

To reduce the risk of injury from loss of control, be absolutely sure that the cutting tool is clear of you and all other obstructions and objects, including the ground, because when the engine starts at starting-throttle, engine speed will be fast enough for the clutch to engage and turn the cutting tool.

Warning!

When you pull the starter grip, don't wrap the starter rope around your hand. Do not allow the grip to snap back, but guide the starter rope to rewind it properly. Failure to follow this procedure may result in injury to hand or fingers and may damage the starter mechanism.

With the engine running but at idle, attach the brushcutter to the spring hook of your harness (see appropriate chapter of this manual).



Warning!



Unit vibrations can cause an improperly tightened fuel cap to loosen or come off and spill quantities of fuel.

In order to reduce risk of fuel spillage and fire, tighten fuel cap by hand with as much force as possible.

The screwdriver end of the STIHL combination wrench or other similar tool can be used as an aid for tightening slotted fuel caps.

Operating instructions



Warning!

Improper use of any brushcutter can cause serious or fatal personal injury. Read, understand and follow all safety instructions in your owner's manual before operating these products. To reduce the risk of personal injury to the operator from blade contact and thrown objects, make sure your unit is equipped with the proper deflector, handle and harness for the type of cutting attachment being used (see chart in chapter on "Selecting the Cutting Tool"). Always wear proper eye protection.

Starting



Warning!

Your brushcutter is a one-person machine. Once started, it may fling foreign objects for a great distance.

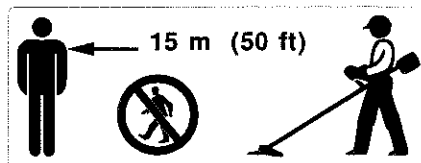

To reduce the risk of eye and other injury insure that bystanders are at least 50 feet (15 m) away. Stop the engine and cutting tool immediately if you are approached. Start and operate your brushcutter without assistance. For specific starting instructions, see the appropriate section of your manual. Place the brushcutter on firm ground or other solid surface in an open area. Maintain a good balance and secure footing.



Warning!

To reduce the risk of injury from loss of control, be absolutely sure that the cutting tool is clear of you and all other obstructions and objects, including the ground, because when the engine starts at starting-throttle, engine speed will be fast enough for the clutch to engage and turn the cutting tool.



Warning!

When you pull the starter grip, don't wrap the starter rope around your hand. Do not allow the grip to snap back, but guide the starter rope to rewind it properly. Failure to follow this procedure may result in injury to hand or fingers and may damage the starter mechanism.

With the engine running but at idle, attach the brushcutter to the spring hook of your harness (see appropriate chapter of this manual).

Working Conditions

Operate and start your brushcutter only outdoors in a ventilated area.



Warning! Your brushcutter produces toxic exhaust fumes as soon as the engine is running. These gases (e.g. carbon monoxide) may be colourless and odourless. To reduce the risk of serious or fatal injury from inhaling toxic fumes, never run the brushcutter indoors or in poorly ventilated locations.



Warning! The muffler and other parts of the engine (e.g. fins of the cylinder, spark plug) become hot during operation and remain hot for a while after stopping the engine. To reduce risk of burns do not touch the muffler and other parts while they are hot.

Operate the brushcutter under good visibility and daylight conditions only. Work carefully.

Do not cut any material other than grass, brush and wood. The cutting tools may be used only for the operations described in your manual.

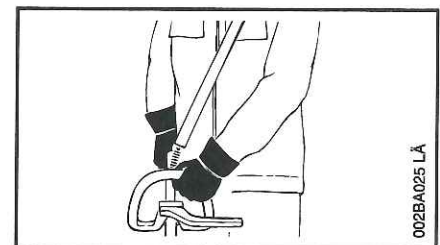
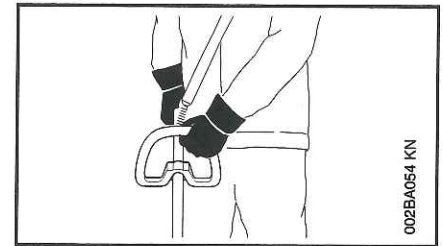
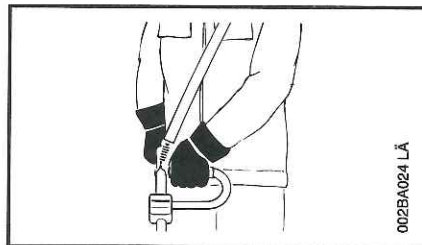
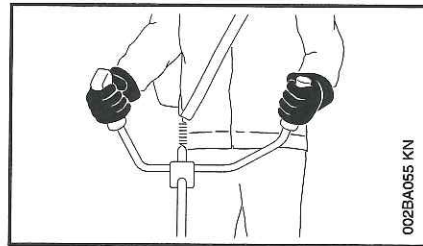

Always hold the brushcutter firmly with both hands. Wrap your fingers tightly around the handles, keeping the handles cradled between your thumb and forefinger. Keep your hands in this position, to have your brushcutter under control at all times. Make sure your brushcutter handles and grip are in good condition and free of moisture, pitch, oil or grease.



Warning! Never attempt to operate any brushcutter with one hand. Loss of control of the brushcutter resulting in serious or fatal injury may result.

To reduce the risk of bodily injury resulting from loss of control and/or contact with the cutting tool, make sure your unit is equipped with the proper handle and harness for the type of cutting attachment being used (see chart in chapter on "Selecting the Cutting Tool").

Special care must be taken in slippery conditions (wet ground, snow) and in difficult, overgrown terrain. Watch for hidden obstacles such as tree stumps, roots and ditches to avoid stumbling.



Before cutting, inspect the area for stones, glass, pieces of metal, trash or other solid objects. The cutting attachment could throw objects of this kind.



To reduce the risk of injury from thrown objects and blade contact, never operate a brushcutter without a properly mounted deflector. Keep the skirt on the deflectors adjusted properly at all times (see chapter on mounting the various cutting tools of your owner's manual). Do not overreach. Keep proper footing and balance at all times.



Warning!
This brushcutter is normally to be used at ground level with the cutting attachment parallel to the ground. Use of a brushcutter above ground level or with the cutting attachment perpendicular to the ground may increase the risk of injury, since the cutting attachment is more fully exposed and the brushcutter may be more difficult to control. Never use your brushcutter as a hedge trimmer.



Warning!
When using rigid blades, avoid cutting close to fences, sides of buildings, tree trunks, stones or other such objects that could cause the brushcutter to kick out or could cause damage to the blade. STIHL recommends use of the nylon line heads or Polycut head for such jobs. In addition, be alert to an increased possibility of ricochets in such situations.

Do not operate using the starting throttle lock as you do not have control of the engine speed. See section of your owner's manual on the proper use of the slide control.

If the cutting tool or deflector becomes clogged or stuck, always turn off the engine and make sure the cutting tool has stopped, before cleaning. Grass, weeds, etc. should be cleaned off the cutting tool at regular intervals.



Warning!
During cutting, check the tightness and the condition of the cutting tool at regular intervals. If the behavior of the tool changes, stop the engine immediately, and check the nut securing the tool for tightness and the cutting tool for cracks and damage. Replace cracked, bent, warped, damaged or dull cutting tools immediately. Such tools may shatter at high speed and cause serious or fatal injury.



Warning!
A loose blade may cause the blade to vibrate, crack, break or come off the brushcutter, which may result in serious or fatal injury. Make sure that the blade is properly tightened. Use the wrench supplied or one of sufficient length to obtain the proper torque. If the blade loosens after being properly tightened, stop work immediately. The retaining nut may be worn or damaged and should be replaced. Never use unauthorized parts to secure the blade. If the blade continues to loosen, see your STIHL dealer. Never use a brushcutter with a loose blade.



Warning!
Keep hands and feet away from cutting tool. Never touch a rotating cutting tool with your hand or any part of your body. It continues to rotate for a short period after the throttle trigger is released (flywheel effect).

Important adjustments

 **Warning!**

To reduce the risk of personal injury from loss of control or contact with the running cutting tool, do not use a cutting tool with incorrect idle adjustment. At correct idle speed, the cutting tool should not move. For directions on how to adjust idle speed, see the appropriate section of your owner's manual.

If you cannot set the correct idle speed, have your STIHL dealer check your brushcutter and make proper adjustments and repairs

MAINTENANCE, REPAIR AND STORING

Maintenance, replacement, or repair of the emission control devices and systems may be performed by any nonroad engine repair establishment or individual. However if you claim warranty for a component which has not been serviced or maintained properly or if nonapproved replacement parts were used, STIHL may deny warranty.

Use only identical STIHL replacement parts for maintenance and repair. Use of non-STIHL parts may cause serious or fatal injury.

Follow the maintenance and repair instructions in the appropriate section of your owner's manual. Please refer to the maintenance chart on the last pages of this manual.

 **Warning!**

Always stop the engine and make sure that the cutting tool is stopped before doing any maintenance or repair work or cleaning the brushcutter. Do not attempt any maintenance or repair work not described in your owner's manual. Have such work performed at your STIHL service shop only.

 **Warning!**

Never repair damaged cutting attachments by welding, straightening or modifying the shape. This may cause parts of the cutting tool to come off and result in serious or fatal injuries.

 **Warning!**

Check condition of cutting tool at regular short intervals. If behavior of tool changes, check it immediately for tightness or any signs of cracks in particular. Replace damaged or dull cutting tools immediately, even if they have only superficial cracks. If the blade loosens after being properly tightened, the retaining nut may be worn or damaged and should be replaced. If the blade continues to loosen, see your STIHL dealer. Do not attach any blade to a unit without proper installation of all required parts. Never use unauthorized parts to secure the blade. Failure to use the proper parts may cause the blade to fly off and seriously injure the operator or bystanders.

**Warning!**

To reduce the risk of fire and burn injuries, check fuel filler cap for leaks at regular intervals. Use the specified spark plug and make sure it and the ignition lead are always in good condition.

**Warning!**

Never test the ignition system with ignition wire boot removed from spark plug or with unseated spark plug, since uncontained sparking may cause a fire.

**Warning!**

To reduce the risk of fire and burn injury, use only spark plugs authorized by STIHL. Always press spark plug boot snugly onto spark plug boot of the proper size. (Note: If boot has detachable SAE adapter nut, it must be attached.) A loose connection between spark plug boot and ignition wire connector in the boot may create arcing that could ignite combustible fumes and cause a fire. Keep spark plug clean, and make sure ignition lead is in good condition.

**Warning!**

Do not operate your brushcutter if the muffler is damaged, missing or modified. An improperly maintained muffler will increase the risk of fire and hearing loss. Never touch a hot muffler or burn will result. If your muffler was equipped with a spark-arresting screen to reduce the risk of fire (e.g. in the USA, Canada and Australia), never operate your brushcutter if the screen is missing or damaged. Do not modify or remove any part of the muffler or spark arresting screen. Remember that the risk of forest fires is greater in hot or dry weather.

Keep cutting tool sharp. Tighten all nuts, bolts and screws, except the carburetor adjustment screws, after each use.

Additionally, the daily maintenance schedule for your brushcutter set forth in your STIHL Owner's Manual should be strictly followed.

Store brushcutter in a dry, high or locked location out of reach of children.

Before storing for longer than a few days, always empty the fuel tank.



USING THE CUTTING TOOLS

For an illustration of the various cutting tools and instructions on proper mounting see the chapter on "mounting the cutting tools" in your owner's manual.

Using the mowing heads

The STIHL Supercut, Autocut, Polymatic and Polycut mowing heads produce a clean and tidy finish.

They are to be used only on brushcutters equipped with a limiter blade in the deflector in order to keep the line at the proper length (see "Parts and Controls" chapter of this manual).

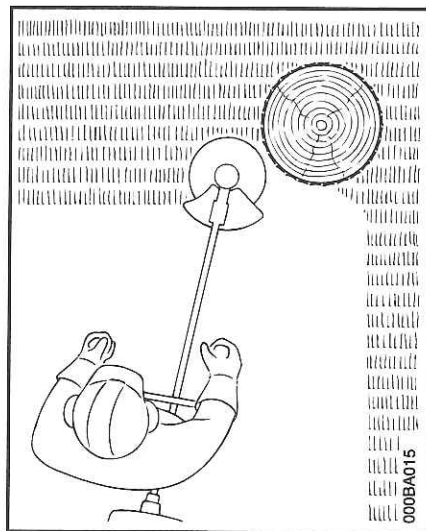

If the lawn edges are planted with trees or bordered by a fence etc., it is best to use a nylon line head. It achieves a "softer" cut with less risk of damaging tree bark etc. than with the polymer blades.

However, the polymer bladed STIHL "Polycut" produces a better cut if there are no plants along the edge of the lawn. Sharpening is not necessary and worn cutting blades are easily replaced.

Warning!

To reduce the risk of serious injury, never use wire or metal-reinforced line or other material in place of the nylon cutting lines. Pieces of wire could break off and be thrown at high speed toward the operator or bystanders.

STIHL "Supercut" mowing head
Fresh line is advanced automatically. Frayed line is replaced by a simple adjustment (see instruction sheet supplied with mowing head).

STIHL "Polymatic" mowing head
Frayed line is replaced by a simple adjustment (see instruction sheet supplied with mowing head).

STIHL "Autocut" mowing head
Nylon cutting cord advances automatically when tapped against the ground.

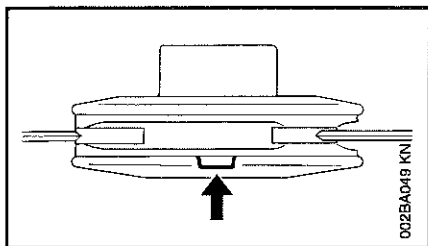

STIHL "Polycut" mowing head

Uses either nylon lines or nonrigid plastic blades

Important!

Three rectangular wear limit marks are applied to the base (periphery) of the Polycut. To reduce the risk of serious injury from breakage of the head or blades, the Polycut must not be used when it has worn as far as one of these marks. It is important to follow the maintenance instructions supplied with the head!

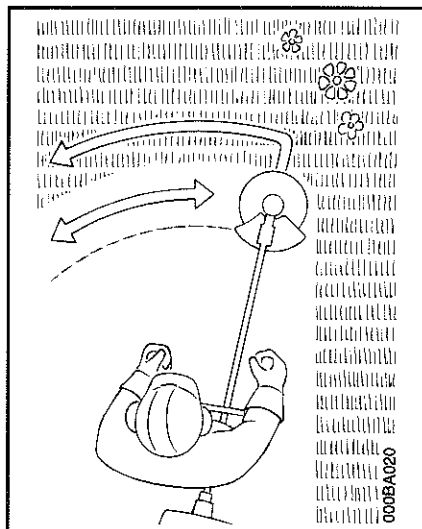

Using the grass cutting blade

All kinds of grass and weeds can be easily cut with the grass cutting blade. The brushcutter is swept in an arc similar to a scythe.



Warning!

To reduce the risk of serious or fatal injury never attempt to cut woody materials.

The **4-tooth** grass cutting blade is intended to cut grass and weeds. It has 4 cutting knives with cutting edges on both sides, i.e. front and rear.

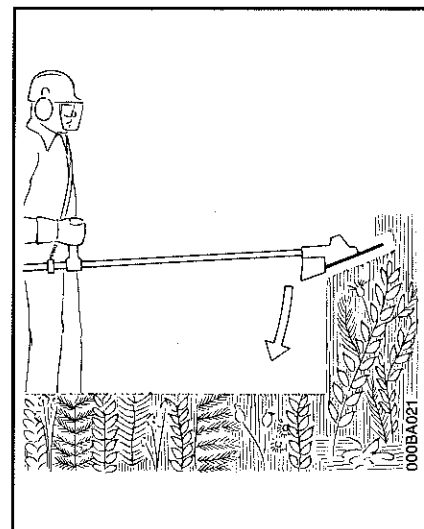

The **8-tooth** grass cutting blade is recommended for cutting fern or reed.

Both blades have to be resharpened when all cutting edges are dull.

Using the brush knife

When fitted to the brushcutter, the brush knife is suitable for applications ranging from cutting matted grass to clearing weeds, wild growth and scrub.

To cut wild growth and scrub, lower the rotating brush knife down onto the growth to achieve a chopping effect. Use the brushcutter like a scythe to cut grass, i.e. sweep it to and for in an arc.



Warning!

When cutting woody materials, use the left side of the blade to avoid "kickout" (blade thrust) situations.



Warning!

Improper use of a brush knife may cause it to crack, chip or shatter. Thrown parts may seriously injure the operator or bystanders. To reduce the risk of personal injury it is essential to take the following precautions:

Avoid contact with hard or solid foreign objects such as stones, rocks or pieces of metal.

Never cut wood or shrubs with a stem diameter of more than 2cm (3/4") - use a circular saw blade for such work. Inspect the brush knife at regular short intervals for signs of damage. Do not continue working with a damaged brush knife. Resharpen the brush knife regularly (when it has dulled noticeably).



Warning!

When cutting young saplings or other woody materials up to 2cm (3/4") in diameter, use left side of the blade to avoid "kickout" situations (see appropriate section in this manual). Do not attempt to cut woody material with a larger diameter, since the blade may

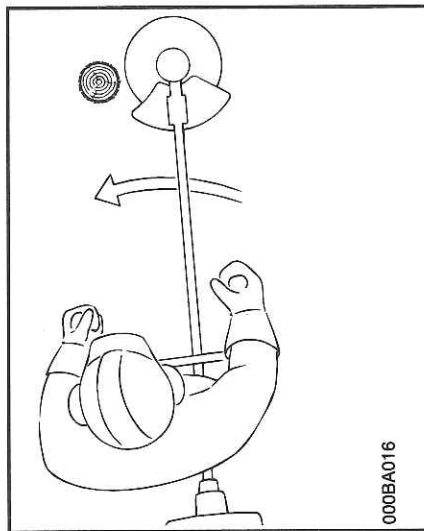

catch or jerk the brushcutter forward. This may cause damage to the blade or brushcutter or loss of control of the brushcutter, resulting in personal injury.

Using the circular saw blade

Circular saw blades are suitable for thinning brush and cutting small trees up to a diameter of 4 cm (1 9/16 in). Do not attempt to cut trees with larger diameters, since the blade may catch or jerk the brushcutter forward. This may cause damage to the blade or loss of control of the brushcutter which may result in serious injury.

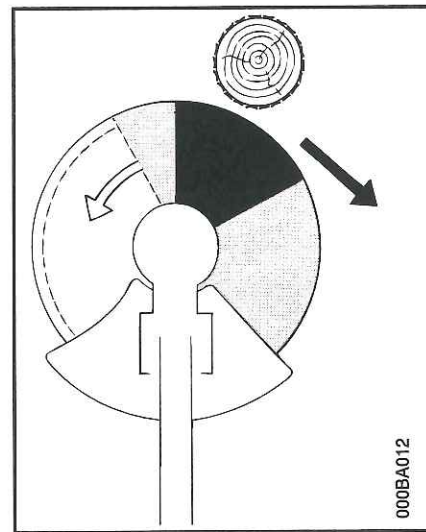

When the brushcutter with circular saw blade is used to cut down small trees, STIHL recommends that the standard deflector be removed and replaced by the special "stop" (see chapter "circular saw blade" for mounting instructions). This stop helps to keep the brushcutter positioned against the tree during the cutting process. Inexperienced users should place the left side of the stop against the tree trunk before beginning to cut. This will keep the brushcutter against the tree during the cutting operation and will reduce the risk of loss of control and possible kickout (described in the following section).

Warning!

In order to reduce the risk of injury from thrown objects or from operator contact with the cutting tool, be sure to remount the standard deflector for all other uses.

Before starting the cut, accelerate the engine up to full throttle. Perform cut with uniform pressure. STIHL recommends that the circular saw blade be applied to the right of the tree, using the non-shaded area of the blade.

Warning!

The risk of kickout is highest when cutting in the darker shaded area. To reduce the risk of kickout and resulting injury, do not use this area of the circular saw blade for cutting trees or shrubs. Special techniques using the lighter shaded areas of the blade to cut shrubs and trees should only be used by experienced operators with specialized training in use and control of the brushcutter.

To reduce the risk of serious injury to the operator or bystanders by a kickout, never use a circular saw blade on a brushcutter with a loop handle.

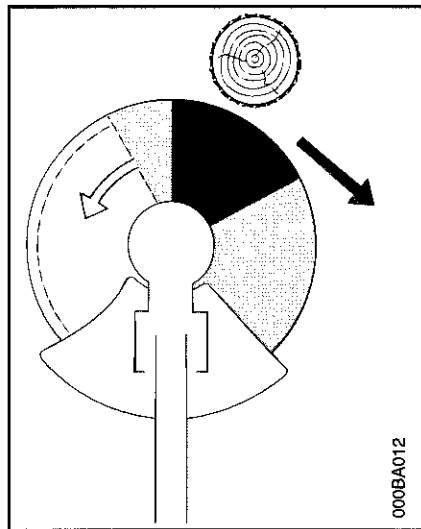

**Risk of "kickout" (blade thrust)
with all rigid cutting blades**

Warning!

Kickout (blade thrust) is the sudden and uncontrolled motion towards the operator's right or rear that can occur when the shaded area of the rotating blade comes in contact with a solid object like a tree, rock, bush or wall. The rapid counterclockwise rotation of the blade may be stopped or slowed, and the cutting attachment may be thrown in an area to the right or to the rear.

This kickout (blade thrust) may cause loss of control of the brushcutter and may result in serious or fatal injury to the operator or bystanders. To reduce the risk of injury, extreme caution should be used when cutting with the shaded area of any rigid blade.

Selecting the Cutting Tool

Cutting tools:

- 1 STIHL Supercut 20-1 cutting head (FS 74 only)
- 2 STIHL Supercut 20-2 cutting head
- 3 STIHL Autocut 20-2 cutting head (FS 74 only)
- 4 STIHL Autocut 21-2 cutting head (FS 74 only)
- 5 STIHL Autocut 25-2 cutting head
- 6 STIHL Autocut 30-2 cutting head
- 7 STIHL Polymatic 30-2 cutting head
- 8 STIHL Polycut 20-3 cutting head

- 9 Cutting blade 230-4
- 10 Cutting blade 230-8
- 11 Brush knife 250

- 12 Circular saw blade 200 (scratcher tooth)
- 13 Circular saw blade 200 (chisel tooth)

Deflectors:

- 14 Deflector for cutting heads
- 15 Deflector for all cutting tools **with**
- 16 Skirt and line limiting blade
- 17 Deflector for all cutting tools **without** skirt and line limiting blade
- 18 Stop for circular saw blades

Handles:

- 19 Loop handle
- 20 Loop handle **with**
- 21 Standoff lever
- 22 Bike handle

Carrying straps:

- 23 Shoulder strap recommended
- 24 Shoulder strap
- 25 Full harness recommended
- 26 Full harness

A fully equipped brushcutter comprises, among other items:

- Cutting tool
- Deflector
- Handle
- Carrying strap

Select the correct combination from the table according to the cutting tool you intend to use:











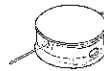
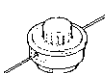

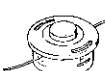
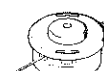

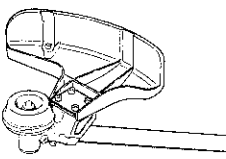
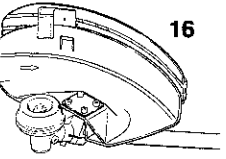







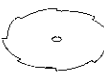

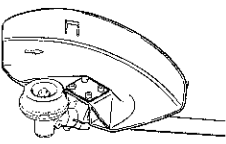
For safety reasons, you may only combine the cutting tool, deflector, handle and carrying strap versions shown when you read **the table horizontally from left to right.**

Other combinations, e.g. reading the table diagonally, are not permitted since there is otherwise a risk of serious injury.

Warning!

STIHL brushcutters with a loop handle **without standoff lever** may be used only with the above-mentioned cutting heads with nylon line or plastic blades.

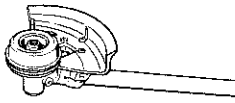
Other plastic or metal cutting tools may only be used on brushcutters with a bike handle, "J"-handle or loop handle **with standoff lever** in order to minimize the risk of personal injury through contact with the cutting tool.

Cutting tools	Deflectors	Handles	Carrying straps
<p>1  2 </p> <p>3  4 </p> <p>5  6 </p> <p>7  8 </p>	<p>14 </p> <p>15 </p>	<p>19  </p> <p>21  22 </p> <p>22 </p>	<p>23 </p> <p>24 </p>
<p>9  10 </p> <p>11 </p>	<p>17 </p>	<p>20  21 </p> <p>22 </p>	<p>24 </p> <p>25 </p>
<p>12  13 </p>	<p>18 </p>	<p>22 </p>	<p>26 </p>

Mounting the Bike Handle

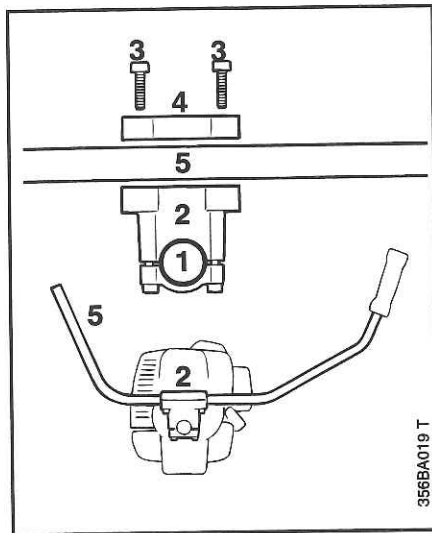

- The handlebar support (2) is mounted on the drive shaft (1). Take out the 4 screws (3) - remove the clamp (4). Position the handlebar (5) in the support and place the clamp over both parts -
- Line up holes in clamp and handlebar support -
 - Insert the screws - screw home as far as stop -
 - Align the handlebar as required -
 - Tighten the screws firmly.

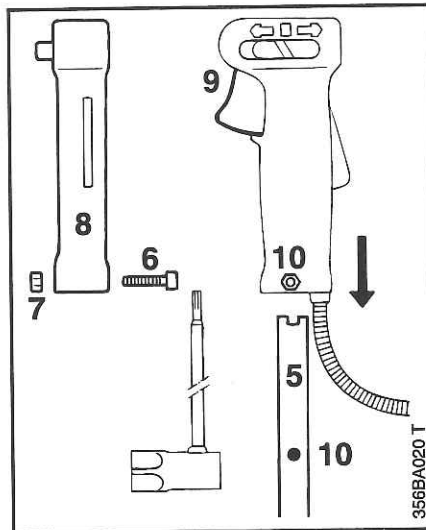

Fitting the control handle

- Remove the screw (6) from the nut (7) - Take both parts out of the control handle (8) -
- Push the control handle onto the handlebar (5) - Throttle trigger (9) must point in direction of gear head. Line up the holes (10) -
 - Fit nut and screw in the control handle -
 - Tighten the screw firmly

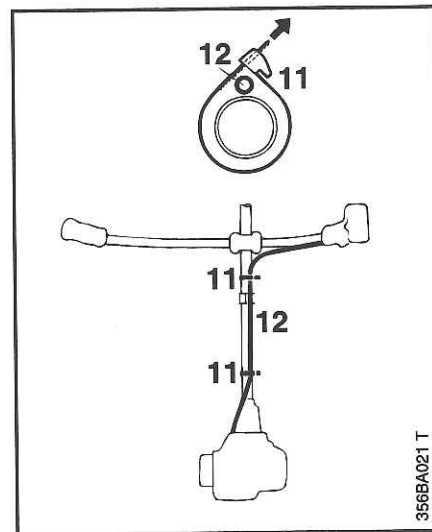

Fitting the throttle cable

Do not kink the throttle cable - make sure the throttle trigger moves freely.

FS 74

Fit hose ties (11) around the drive shaft and throttle cable (12), close them and pull tight.

Mounting Loop Handle with Standoff Lever

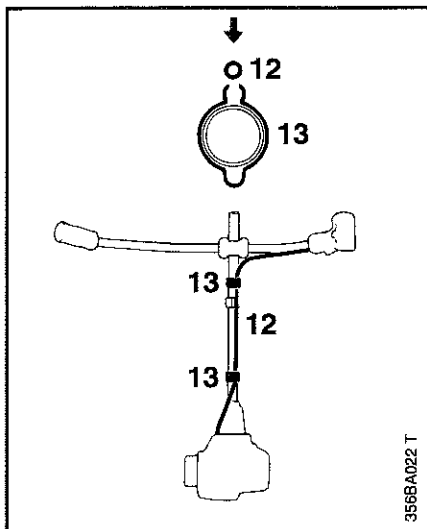

FS 76

Press throttle cable (12) into the retainers (13).

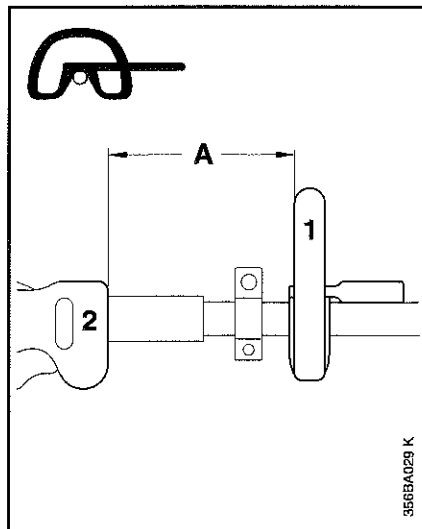

- Mount the loop handle (1) with standoff lever 20 cm/8" (A) forward of the control handle (2).

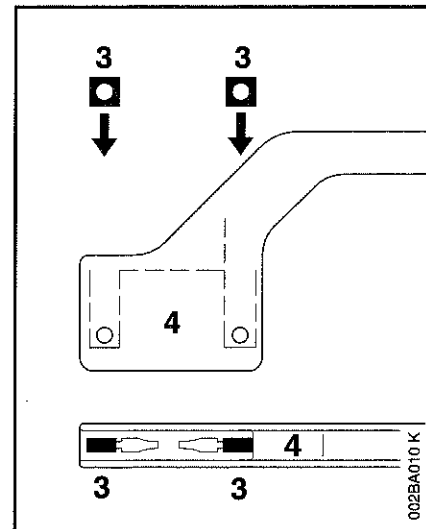

- Insert square nuts (3) in the standoff lever (4) - line up the holes.

Mounting the Loop Handle Version A

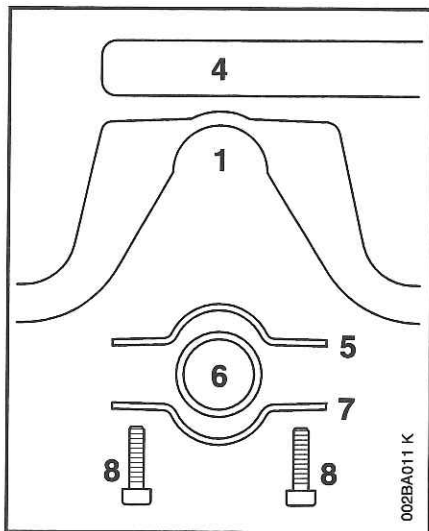

- Place the clamp (5) in the loop handle (1) and position them both against the drive tube (6).
- Fit the clamp (7) and place standoff lever (4) in position - line up the holes.
- Insert screws (8) in holes and screw them into standoff lever fingertight.
- Align the loop handle.
- Tighten the screws firmly.

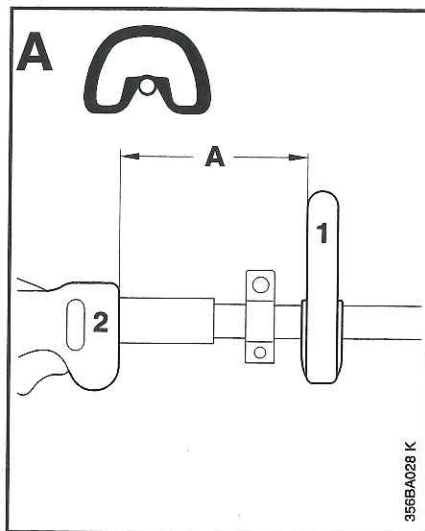

- Mount the loop handle (1) 20 cm/8" (A) forward of the control handle (2).

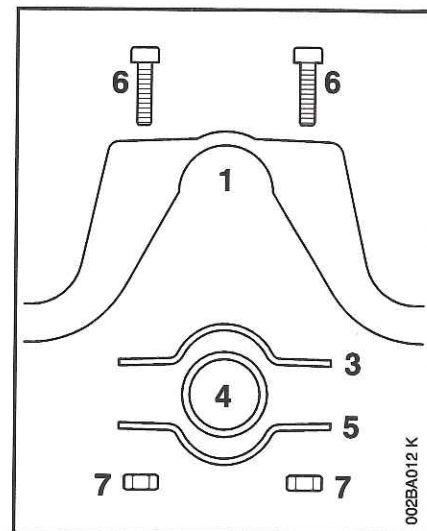

- Place the clamp (3) in the loop handle (1) and position them both against the drive tube (4).
- Fit the clamp (5) - line up the holes.
- Insert screws (6) in holes and screw on the nuts (7) fingertight.
- Align the loop handle.
- Lock the nuts and tighten the screws firmly.

Mounting the Loop Handle Version B

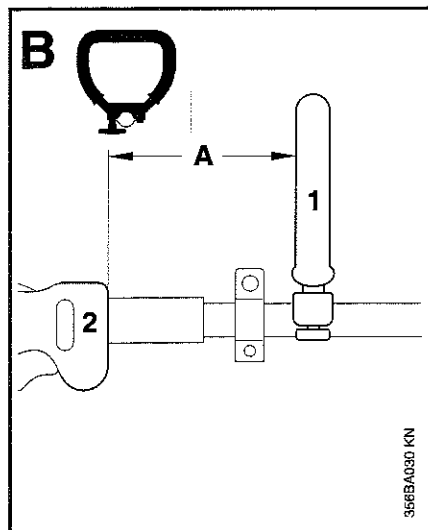

- Mount the loop handle (1) on the drive tube - 15cm/6" (A) forward of the control handle (2).
- Position clamp (3) against the drive tube and slide it into the loop handle.

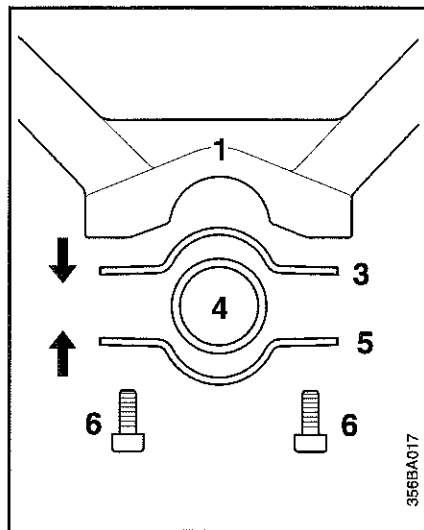

- Fit square nut (4) in the loop handle.
- Insert the clamp screw (5) from the other side and tighten down securely.

Adjusting loop handle to most comfortable position:

- Release clamp screw (5).
- Move the loop handle along the drive tube as required and then tighten the clamp screw.

Mounting the Deflector

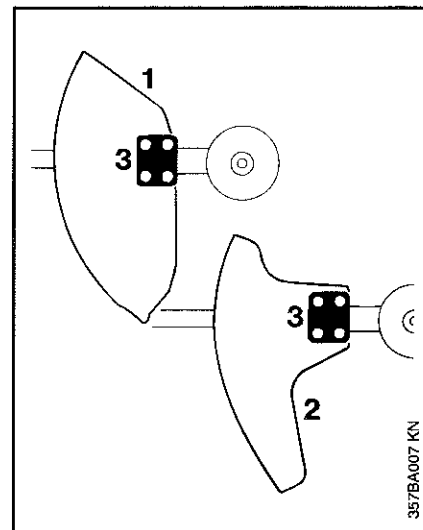

- Place the deflector (1) for all cutting tools or deflector (2) for mowing heads on the gearhead flange -
- Fit the plate (3) and line it up -
- Insert M 5 x 18 screws and tighten down securely.

Mounting the Cutting Tools

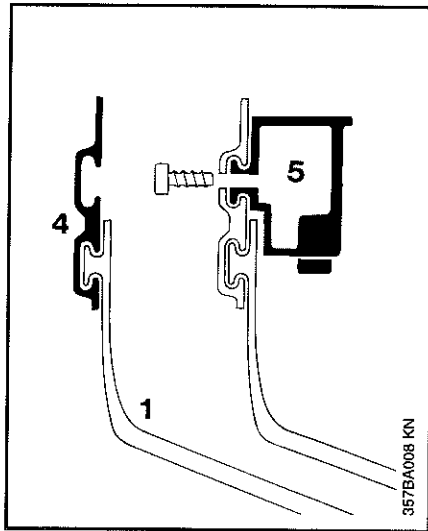

Fitting skirt and blade

- Slide the **lower** guide slot of the skirt (4) on to the deflector (1) - it must snap into position.
- Push blade (5) into the **upper** guide on the skirt and line it up with the first hole.
- Fit the screw and tighten it down firmly.

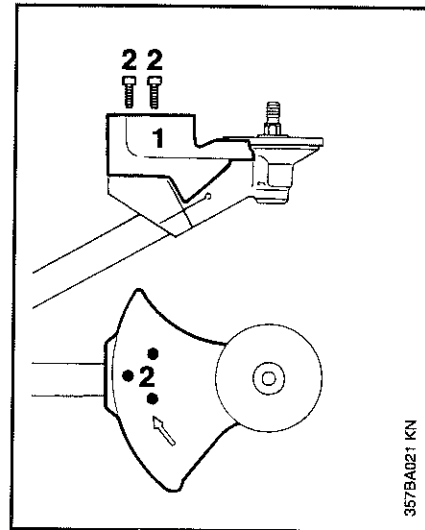

Fitting stop - for circular saw blades

- Remove standard deflector. Place the stop (1) on the gear head flange - fit the three M 5 x 18 screws (2) provided and tighten down securely.

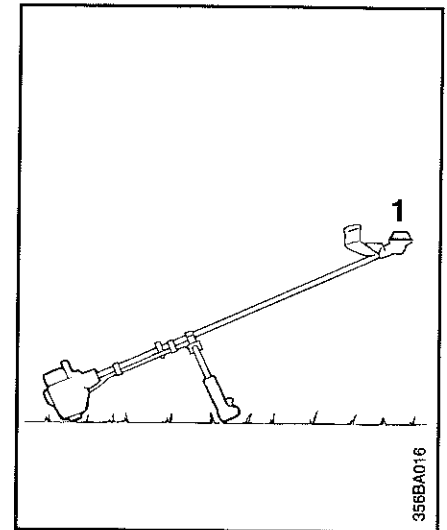

Preparations

- Lay your brushcutter on its back with the gear head (1) facing upward.

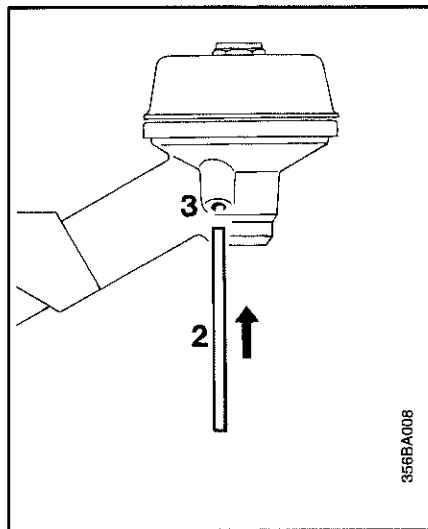

Blocking drive shaft

Insert the stop pin (2) in the bore (3) at the side of the gear head - as far as stop - apply slight pressure.

- Rotate the drive shaft until the stop pin slips into position and blocks the drive shaft.

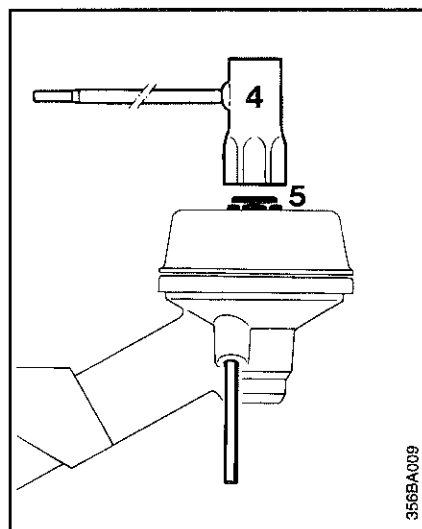

Removing cutting tool mounting hardware

Position combination wrench (4) on the mounting nut (5).

- Release and unscrew the nut clockwise (left-hand thread).

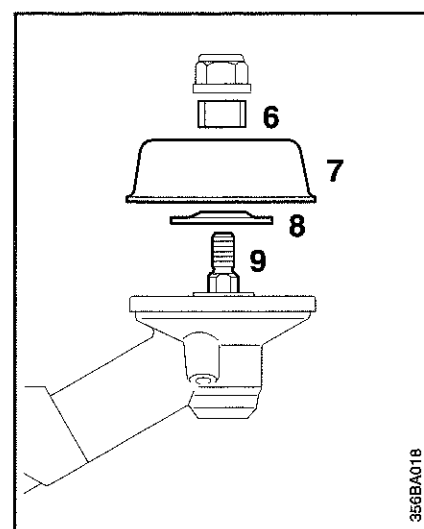

Remove shipping keeper (6) - if fitted.

Pull the rider plate (7) and thrust washer (8) off the shaft (9).

- Now fit the cutting tool.

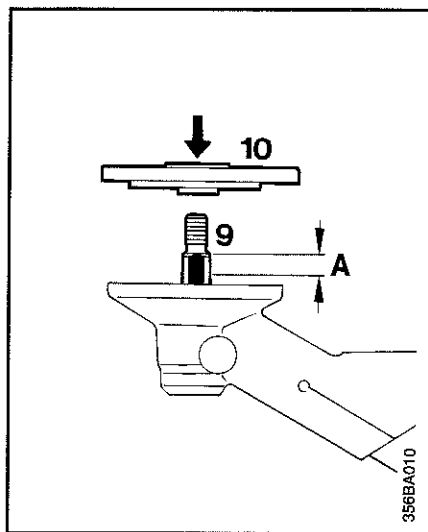

FS 74

Fit the thrust plate (10) over the shaft (9) - as far as stop - the two flats must project about 8mm/0.3" (A).

- Now fit the cutting tool.

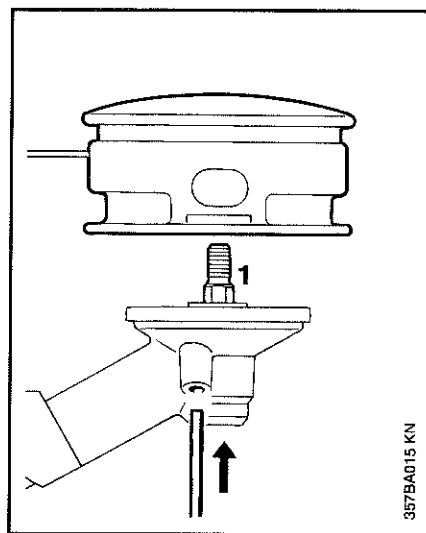

STIHL "Supercut 20-1" mowing head STIHL "Supercut 20-2" mowing head

- Lay your brushcutter on its back with the gear head facing upward.
- Screw mowing head counterclockwise onto the drive shaft (1) - as far as it will go -
- Block the drive shaft -
- Tighten down the mowing head securely.

Important!

- Remove the stop pin.

Keep instruction sheet for mowing head in a safe place.

Removing mowing head

- Block the drive shaft and unscrew the mowing head clockwise.

Adjusting nylon line

- Fresh line is advanced automatically, providing at least 6cm/2.5" of line is still projecting from the head -
- Blade on deflector trims surplus line to correct length.
- Fit new nylon line as described in instructions supplied with mowing head.

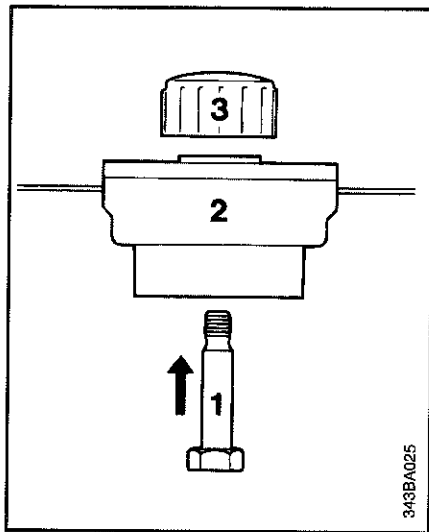

STIHL "Autocut 20-2" mowing head
 STIHL "Autocut 25-2" mowing head
 STIHL "Autocut 30-2" mowing head

Assembling Autocut 20-2 mowing head

- Push the bolt (1) into the head (2) and engage it in the hexagon recess -
- Screw the cap (3) counterclockwise on to the bolt and tighten it down securely.

Keep instruction sheet for mowing head in a safe place.

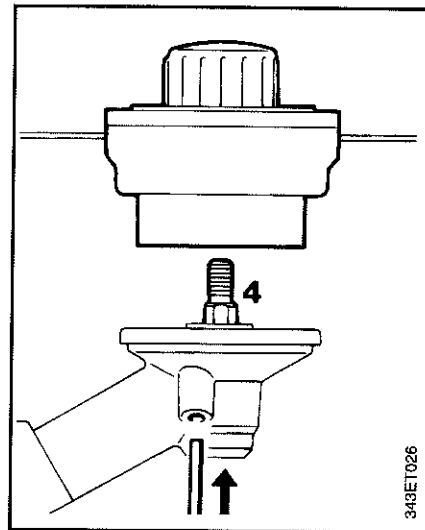

Mounting the mowing head

- Lay your brushcutter on its back with the gear head facing upward.
- Screw mowing head counterclockwise onto the drive shaft (4) - as far as it will go -
- Block the drive shaft -
- Tighten down the mowing head securely.

Important!

- Remove the stop pin.

Removing mowing head

- Block the drive shaft and unscrew the mowing head clockwise.

Adjusting nylon line

- Hold the rotating mowing head horizontal above the lawn - tap it on the ground - about 3cm/1 1/4" fresh line is advanced - blade on deflector trims surplus line to the correct length - avoid tapping head more than once.
- Line feed operates only if both lines still have a minimum length of 2.5 cm/1".
- Fit new nylon line as described in instructions supplied with mowing head.

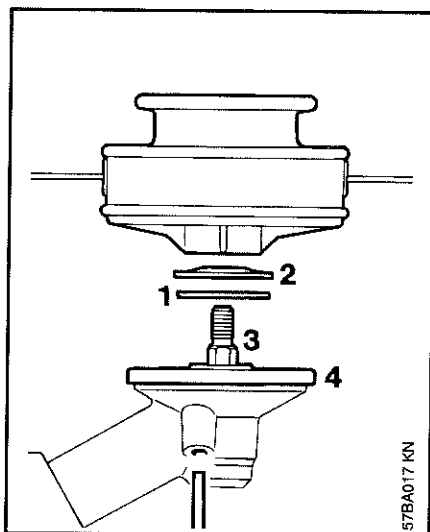

57BA017 KN

STIHL "Polymatic 30-2" mowing head
STIHL "Autocut 24-2" mowing head

- Lay your brushcutter on its back with the gear head facing upward. Slip the washer (1) and thrust washer (2) over the drive shaft (3) and against the thrust plate (4) -
- Screw mowing head counterclockwise onto the drive shaft - as far as it will go -
- Block the drive shaft -
- Tighten down the mowing head securely.

Important!

- Remove the stop pin.

Removing mowing head

- Block the drive shaft and unscrew the mowing head clockwise.

Adjusting nylon line

- Refer to instruction sheet supplied with mowing head.

Keep instruction sheet for mowing head in a safe place.

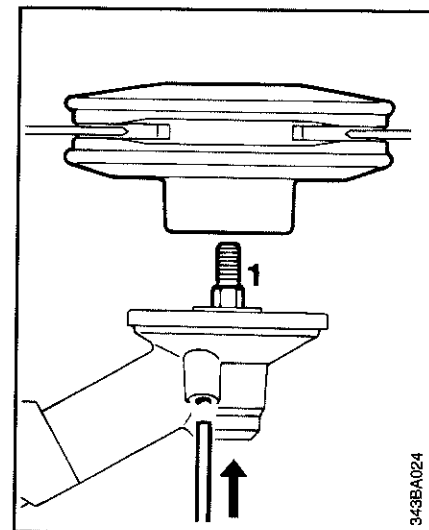

343BA024

STIHL "Polycut 20-3" mowing head

- Lay your brushcutter on its back with the gear head facing upward.
- Screw mowing head counterclockwise onto the drive shaft (1) - as far as it will go -
- Block the drive shaft -
- Tighten down the mowing head securely.

Important!

- Remove the stop pin.

Keep instruction sheet for mowing head in a safe place.

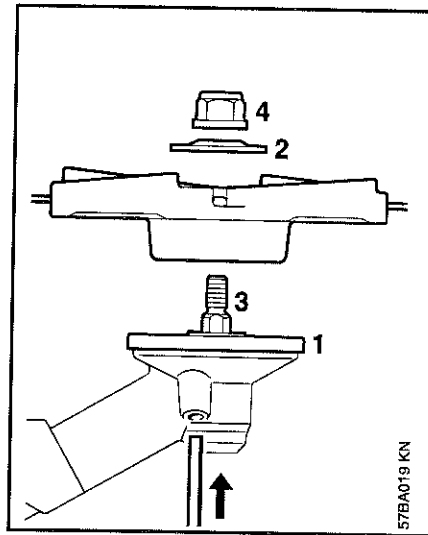

Removing mowing head

- Block the drive shaft and unscrew the mowing head clockwise.

Replacing cutting blades

- Refer to instruction sheet supplied with mowing head.

STIHL "Fixed Line Head"

- Lay your brushcutter on its back with the gear head facing upward.
- Position the mowing head on the thrust plate (1) - slip the thrust washer (2) over the drive shaft (3) -
- Block the drive shaft - Screw mounting nut (4) clockwise on to the drive shaft and tighten it down firmly.

Important!

- Remove the stop pin.

Keep instruction sheet for mowing head in a safe place.

Releasing mounting nut

- Block the drive shaft and unscrew the mounting nut clockwise.

If the mounting nut becomes slack due to frequent loosening and retightening, fit a new one.

Fitting nylon line

- Refer to instruction sheet supplied with mowing head.

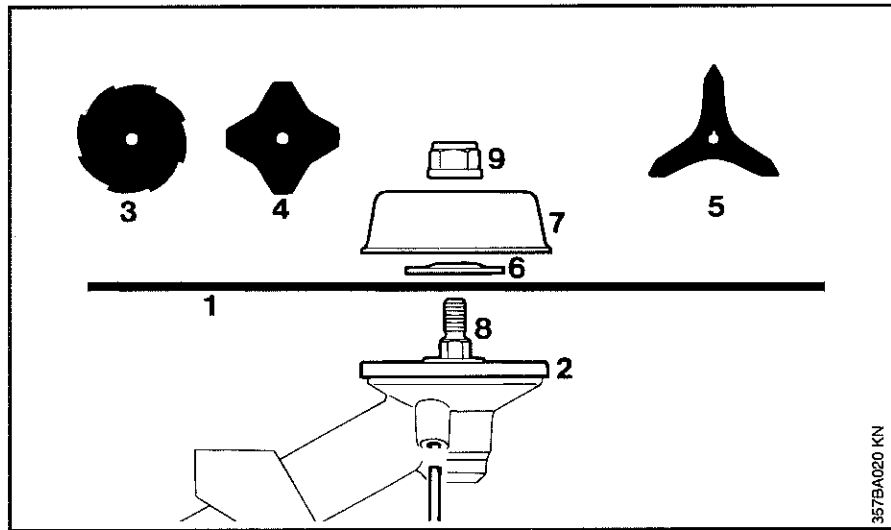

357BA020 KN

**Grass cutting blade 230
Brush knife 250**

Note: Remove skirt and blade from deflector before mounting these cutting tools.

- Lay your brushcutter on its back with the gear head facing upward. Place cutting tool (1) on the thrust plate (2) - Cutting edges of cutting blade 230-8 (3) must point clockwise. Cutting blade 230-4 (4) and brush knife 250 (5) may be fitted either way round.

Slip the thrust washer (6) and rider plate (7) over the drive shaft (8) -

- Block the drive shaft - Screw mounting nut (9) counterclockwise on to drive shaft and tighten down securely.

Releasing mounting nut

- Block the drive shaft and unscrew the mounting nut clockwise.

If the mounting nut becomes slack due to frequent loosening and retightening, fit a new one.

**Circular saw blade 200
(chisel and scratcher tooth)**

Fit the appropriate stop before mounting circular saw blade.

Fitting the stop see chapter "Mounting the Deflector".

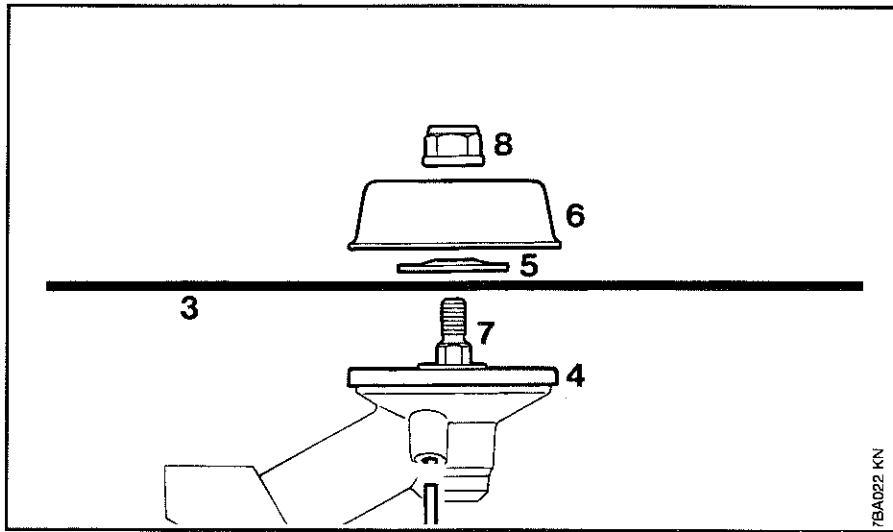

Mounting circular saw blade

- Lay your brushcutter on its back with the gear head facing upward. Position saw blade (3) on the thrust plate (4) - teeth must point in clockwise direction - Slip the thrust washer (5) and rider plate (6) over the drive shaft (7) -
- Block the drive shaft - Screw mounting nut (8) counterclockwise on to drive shaft and tighten down securely.

Releasing mounting nut

- Block the drive shaft and unscrew the mounting nut clockwise.
- If the mounting nut becomes slack due to frequent loosening and retightening, fit a new one.

Your two-stroke engine requires a mixture of brand-name gasoline and quality two-stroke engine oil with the **classification TC**.

Use regular branded unleaded gasoline with a minimum octane number of 90 ROZ (U.S.A./Canada: pump octane min. 89!). If the octane number of the regular grade gasoline in your area is lower use premium unleaded fuel. Fuel with a lower octane number may result in preignition (causing "pinging") which is accompanied by an increase in engine temperature. This, in turn, increases the risk of the piston seizure and damage to the engine.

The chemical composition of the fuel is also important. Some fuel additives not

only detrimentally affect elastomers (carburetor diaphragms, oil seals, fuel lines etc.), but magnesium castings as well. This could cause running problems or even damage the engine. For this reason it is essential that you use only name branded fuels!

Use only STIHL two-stroke engine oil or equivalent branded two-stroke air-cooled engine oils with the classification TC for mixing.

We recommend STIHL 50:1 two-stroke engine oil since it is specially formulated for use in STIHL engines. The mix ratio with STIHL oil is 50:1 (50 parts gasoline to 1 part oil), or 25:1 (25 parts gasoline to 1 part oil) with other branded two-stroke-air-cooled engine oils.

Do not use BIA or TCW (two-stroke water cooled) mix oils!
 Take care when handling gasoline. Avoid direct contact with the skin and avoid inhaling fuel vapour.
 The canister should be kept tightly closed in order to avoid any moisture getting into the mixture.
 The fuel tank and the canister in which fuel mix is stored should be cleaned from time to time.

Fuel mix ages:

Only mix sufficient fuel for a few days work, not to exceed 30 days of storage. Store in approved safety fuel-canisters only. When mixing, pour oil into the canister first, and then add gasoline.

Gasoline	STIHL engine oil 50:1		Other branded TC oils 25:1	
	Liters	(cc)	Liters	(cc)
1	0.02	(20)	0.04	(40)
5	0.10	(100)	0.2	(200)
10	0.20	(200)	0.4	(400)
15	0.30	(300)	0.6	(600)
20	0.40	(400)	0.8	(800)
25	0.50	(500)	1.0	(1000)

Gasoline	STIHL engine oil 50:1		Other branded TC oils 25:1	
	US gal.	US fl.oz	US gal.	US fl.oz
1	2.6		5.1	
2 1/2	6.4		12.8	
5	12.8		25.6	

Fueling

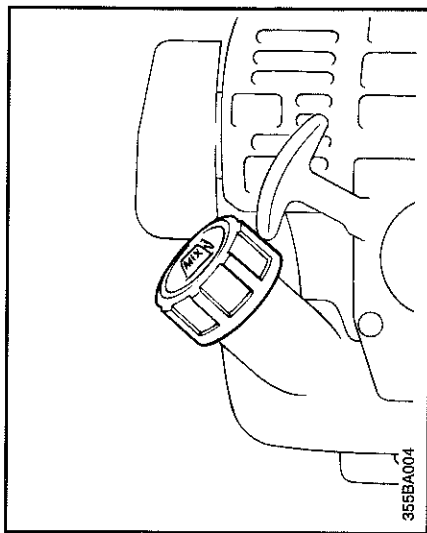

Before fueling, clean the filler cap and the area around it to ensure that no dirt falls into the tank.

Always thoroughly shake the mixture in the canister before fueling your machine.

Warning!

In order to reduce the risk of burns or other personal injury from escaping gas vapor and fumes, remove the fuel filler cap carefully so as to allow any pressure build-up in the tank to release slowly.

Warning!

After fueling, tighten fuel cap as **securely as possible** by hand.

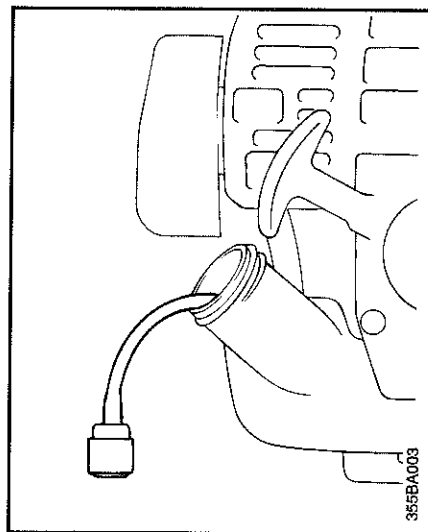

Change the fuel pick up body every year.

Before storing your machine for a long period, drain and clean the fuel tank and run engine until carburetor is dry.

Fitting the Harness

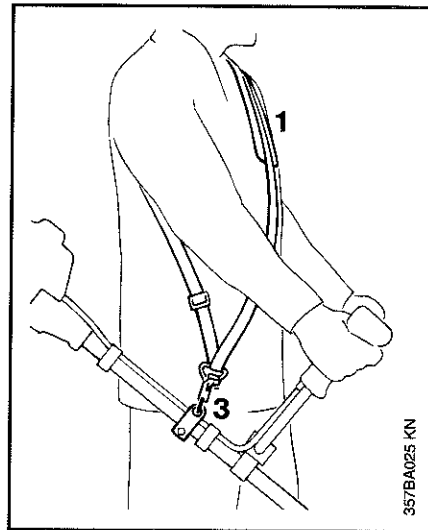

Models with a loop handle come without a harness (available as special accessory for these models).

Shoulder strap

- Put on the shoulder strap (1).
- Adjust length until the spring hook (3) rests against your right hip.

Use of the carrying strap is described in chapters "Safety Precautions" and "Selecting the Cutting Tool".

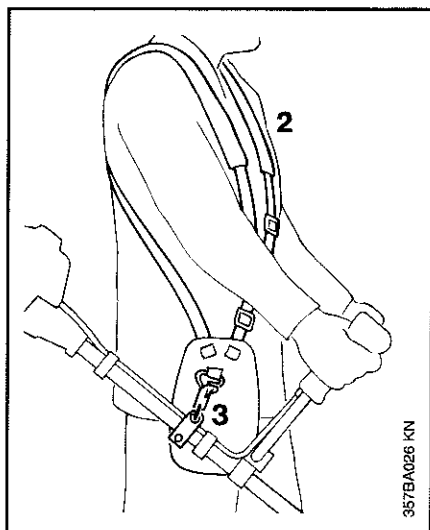

Full harness

- Put on the full harness (2).
- Adjust length until the spring hook (3) rests against your right hip.

Use of the carrying strap is described in chapters "Safety Precautions" and "Selecting the Cutting Tool".

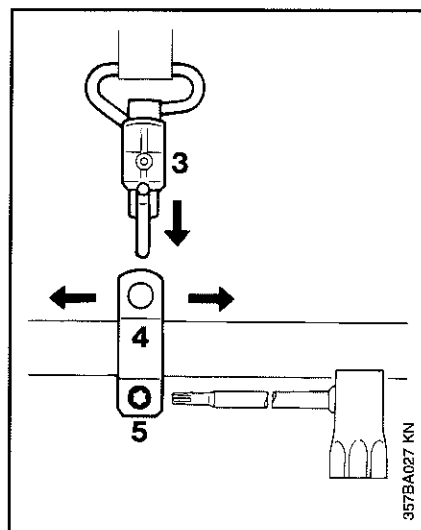

Balancing the brushcutter

- Attach the spring hook (3) to the clamp (4) on the drive shaft - slacken the screw (5) -
- Slide the clamp up or down the drive shaft -
- Tighten the screw moderately.

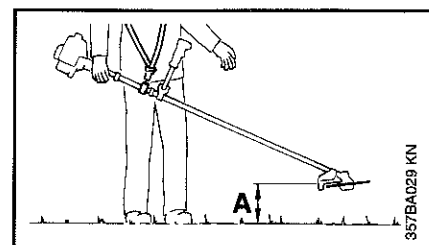
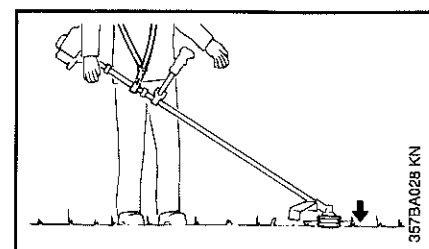

- Let go of the brushcutter and check to see how it is balanced -

mowing heads, cutting blade and brush knife must rest on the ground..
Circular saw blades must stay about 30cm/1ft (A) clear of the ground..

Starting

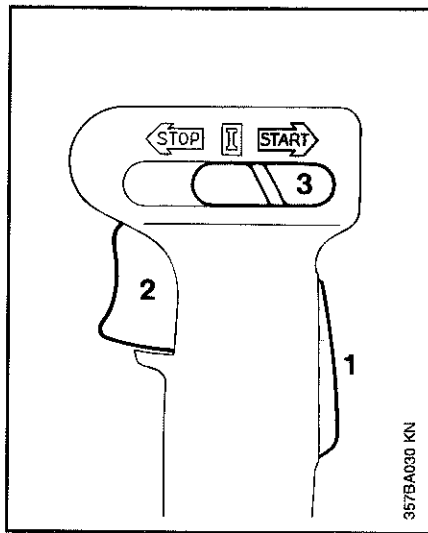

- Observe safety precautions - see section "Safety Precautions" in this manual.

Hold down the throttle trigger interlock (1) and squeeze the throttle trigger (2). Move the slide control (3)

- to **START** position.
- Now release the throttle trigger, slide control and trigger interlock in that order = This is the **starting-throttle position**.

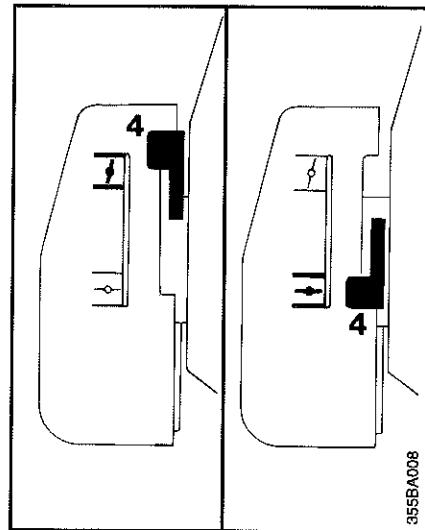

Set the choke lever (4):

For cold start to

For warm start to

(even if engine has been running but is still cold)

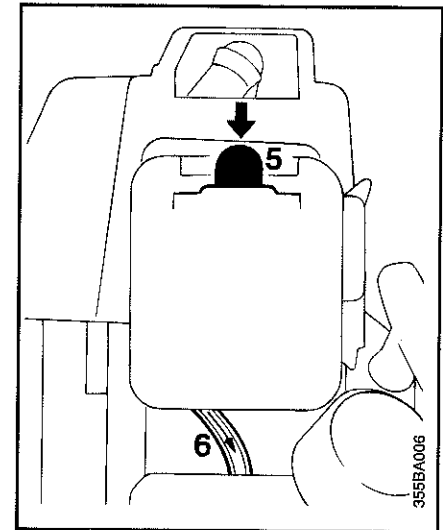

Press fuel pump bulb (5) several times - until you see fuel flowing in the transparent hose (6).

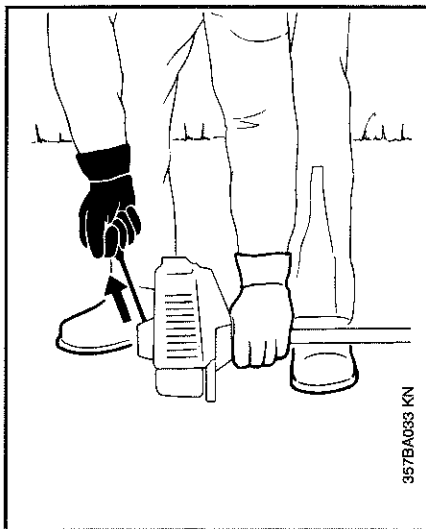

- Put the unit on the ground: It must rest securely on the engine support and deflector. Check that the cutting tool is not touching the ground or any other obstacles.
- Make sure you have a firm footing: Hold the unit with your left hand and press it down **firmly**. Do not stand or kneel on the drive shaft.

- Pull the starter grip slowly with your right hand until you feel it engage - and then give it a brisk strong pull. Do not pull out starter rope more than 75cm (30") - it might break.

Do not let the starter grip snap back - guide it slowly into the housing so that the starter rope can rewind properly.

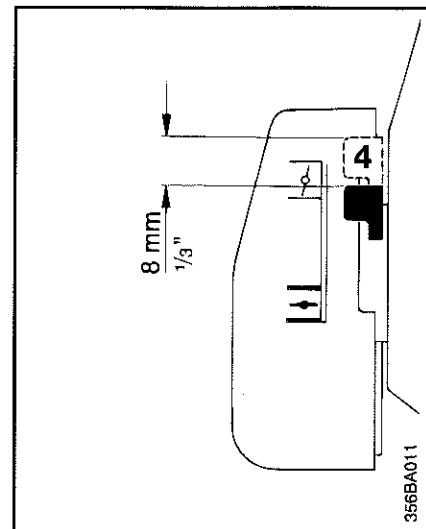

When engine begins to fire:

If engine is **cold** - move choke lever (4)

about 8 mm (1/4") in direction of 

You will notice an increase in resistance - choke shutter is now **partly** open - continue cranking.

If engine is **warm** - continue cranking.

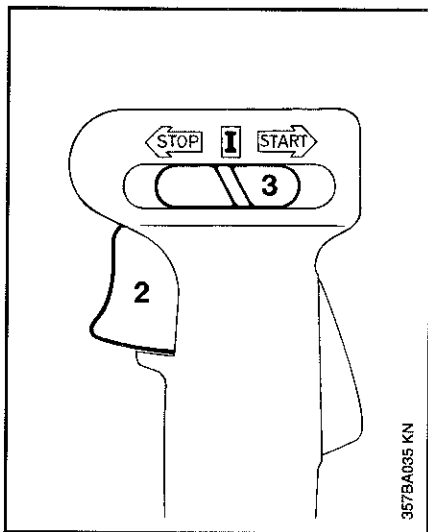

As soon as **cold engine** is running:

Squeeze throttle trigger (2) -
warm up engine at full throttle for
short period -
let go of throttle trigger -
Slide control (3) jumps to

- "Run" position **I**

and the engine settles down to idling
speed.

- Move choke lever
immediately to 

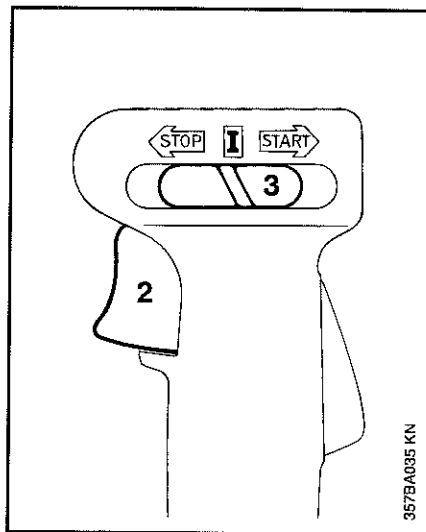

As soon as **warm engine** is running:

Blip the throttle trigger (2) -
Slide control (3) jumps to

- "Run" position **I**

and the engine settles down to idling
speed.

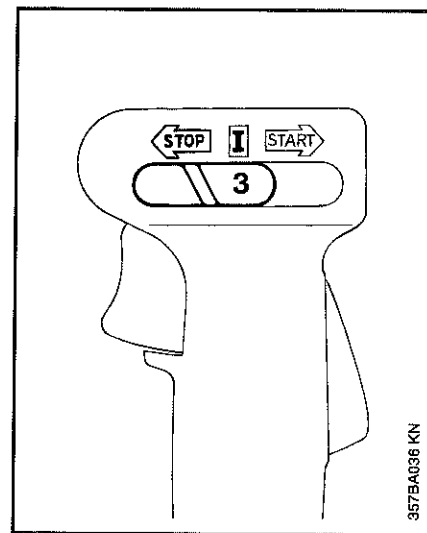

Make sure carburetor is correctly
adjusted - cutting tool must not
rotate when engine is idling.

Your brushcutter is ready for
operation.

To shut down engine:
Move slide control (3) to **STOP**

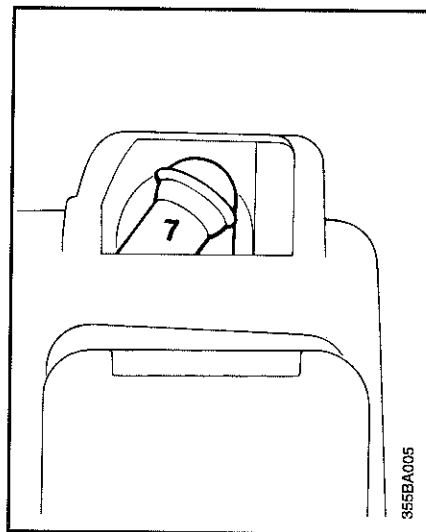

**At very low outside temperatures:
Allow engine to warm up.**

- As soon as engine is running:
● Open choke shutter **part way** -
open throttle slightly -
warm up engine for short period.
Let go of throttle trigger to
disengage it from starting throttle
position -
slide control jumps to

"Run" position **I**

and the engine settles down to
idling speed.

If the engine doesn't start:

If you did not move the
choke lever to 

quickly enough after the engine
began to fire, the combustion
chamber has flooded.

- Remove spark plug terminal (7) -
- Unscrew and dry off the
spark plug -
- Set slide control to **STOP** -
- Open the throttle fully -
- Pull the starter rope several
times to clear the combustion
chamber -

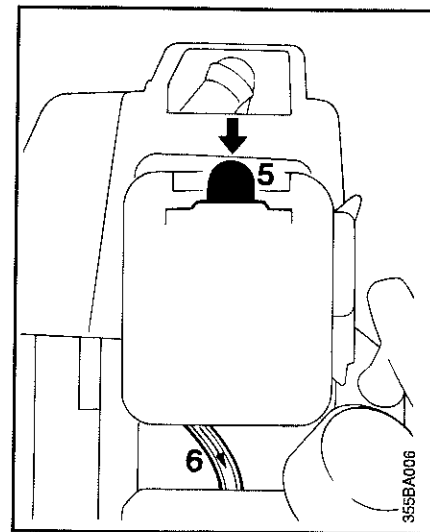

- Refit the spark plug and connect
the spark plug terminal -
- Set slide control to **START** -
- Set choke lever to 
- even if engine is cold.
- Now start the engine.

**Fuel tank run until dry
and then refueled**

- Press fuel pump bulb (5) several
times - until you see fuel flowing
in transparent hose (6) -
- Now start the engine.

Adjusting Carburetor

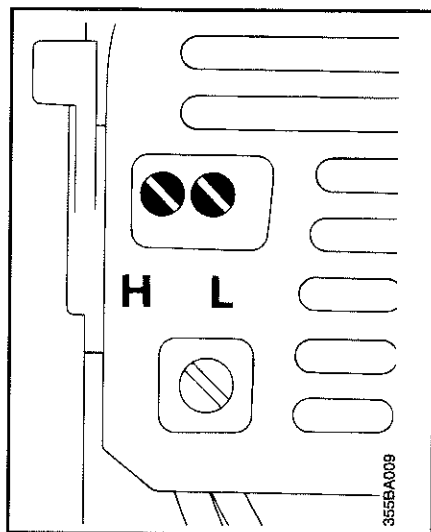

The carburetor has been adjusted for optimum performance under the barometric pressure and climatic conditions at the factory.

Basic setting

This setting is the starting point for fine tuning and can be used as a **standard setting**.

- Check air filter and clean it if necessary.
Carefully screw the high speed adjusting screw (**H**) and low speed adjusting screw (**L**) down onto their seats (clockwise).
Now rotate them counterclockwise as follows:

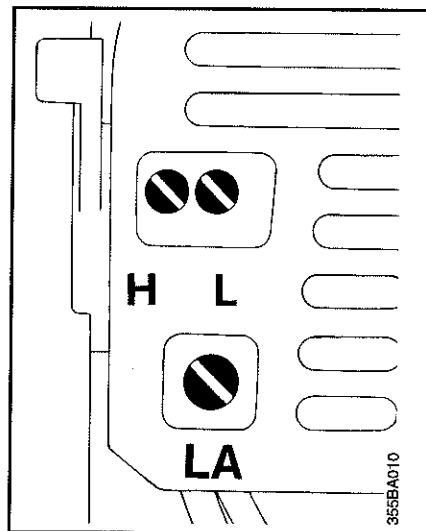

- H** 1 full turn
- L** 1 full turn

- Start the engine and adjust idling speed with the idle speed adjusting screw (**LA**):
cutting tool must not rotate.

This is the optimum setting of the high speed adjusting screw for normal operation at an altitude of about 300 m/ 1000 ft above sea level.

It ensures your machine will deliver maximum power, be fuel efficient and operate reliably.

It may be necessary fine-tune the carburetor **if operating conditions change**, e.g. higher or lower altitudes, extreme changes in humidity and temperature or **if you fit a different cutting tool**:

The fine tuning procedures described below ensure maximum performance under the new operating conditions.

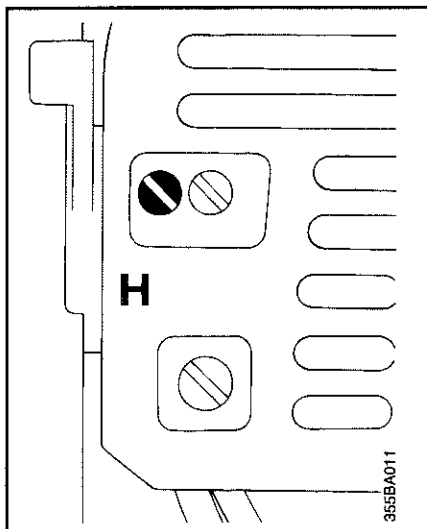

Fine tuning

- Mount the cutting tool.

Machines with cutting head:

- Trim line to correct length: Lines must extend as far as line limiting blade on the deflector.
- Carry out the basic setting.
- Warm up engine by running it for about 1 minute at full throttle and then return to idle speed. Back off high speed adjusting screw (H) one half turn (counterclockwise).
- Run engine at full throttle and rotate high speed adjusting screw (H) carefully clockwise until you hear

no further increase in r.p.m. - back off screw 1/8 turn from this position (counterclockwise).

Machines with metal cutting tool:

A **tachometer** is necessary for the following adjustment.

If no tachometer is available, do not turn screws beyond the basic setting.

- Carry out the basic setting.
- Warm up engine by running it for about 1 minute at full throttle and then return to idle speed.

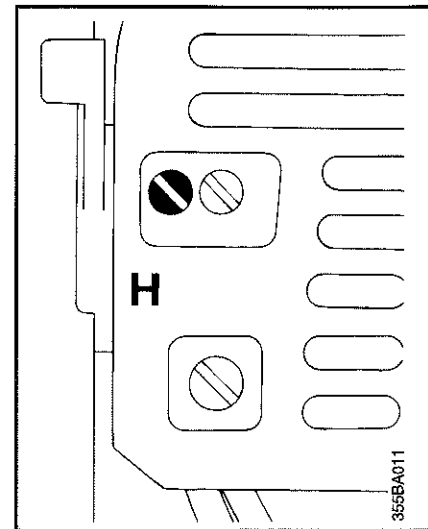

Back off high speed adjusting screw (H) one half turn (counterclockwise).

- Run engine at full throttle and rotate high speed adjusting screw (H) carefully clockwise until maximum speed between 9,500 and 11,500 r.p.m. is reached (speed limited by control valve).

Turning the screw (H) any further in the clockwise direction will make the fuel-air mixture too lean -

this could damage the engine.

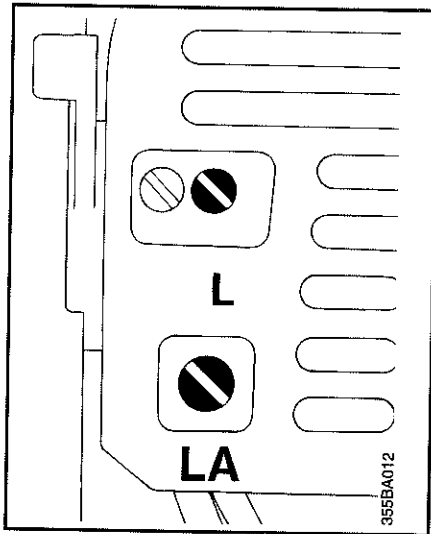

Adjusting idle speed

It is usually necessary to change the setting of the idle speed adjusting screw (**LA**) after every correction to the low speed adjusting screw (**L**).

Engine stops while idling

Turn the idle speed adjusting screw (**LA**) clockwise until engine runs smoothly - cutting tool must not rotate.

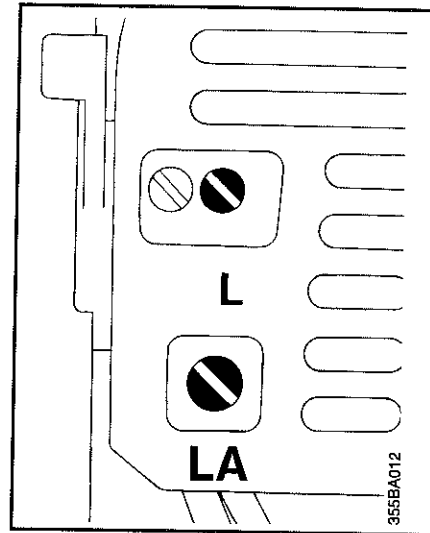

Cutting tool rotates when engine is idling

Turn the idle speed adjusting screw (**LA**) counterclockwise until cutting tool stops rotating - then back off screw about another one half turn from that position.

Erratic idling behavior, poor acceleration

Idle setting is too lean. Turn the low speed adjusting screw (**L**) counterclockwise until engine runs and accelerates smoothly.

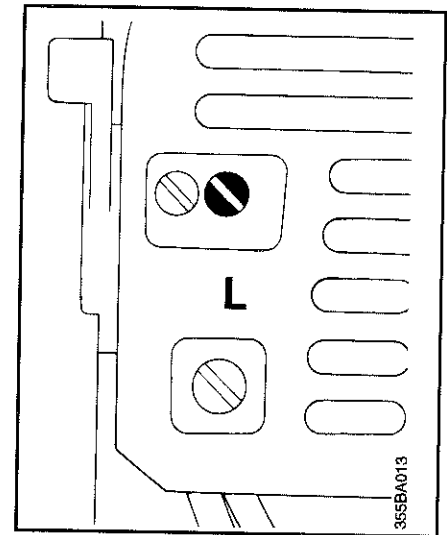

Exhaust smokes at idle speed

Idle setting is too rich. Turn the low speed adjusting screw (**L**) clockwise until engine speed drops. Then turn screw back one quarter turn and check that engine still accelerates smoothly when you open the throttle.

Checking Spark Plug

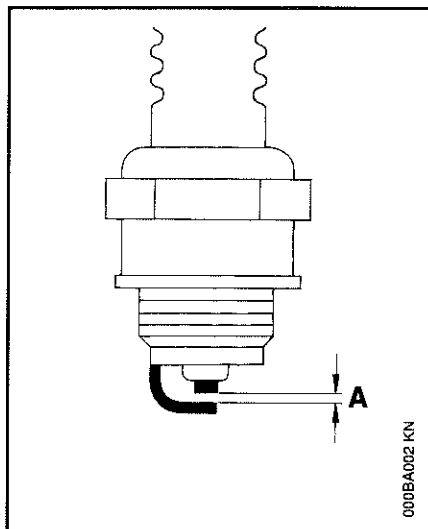

If engine is down on power, difficult to start or runs poorly at idling speed, first check the spark plug.

- Remove spark plug as described in chapter "Starting".
- Check electrode gap (A) - it should be 0.5 mm (0.02") - correct if necessary.
- Keep spark plug clean, and make sure ignition lead is in good condition.

Rectify faults which have caused fouling of spark plug:
Incorrect carburetor setting, too much oil in fuel mix, dirty air filter, unfavorable running conditions, e.g. operating at part load.

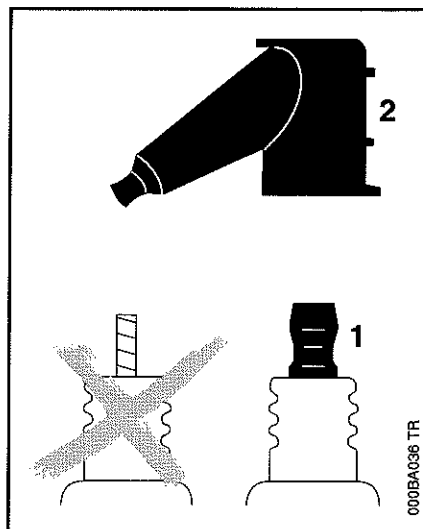

Fit a new spark plug after approx. 100 operating hours - or sooner if the electrodes are badly eroded.

Warning!

To reduce the risk of fire and burn injury, use only spark plugs authorized by STIHL. Always press spark plug boot (2) snugly onto spark plug terminal (1) of the proper size. (Note: If terminal has detachable SAE adapter nut, it must be attached.) A loose connection between spark plug boot and ignition wire connector in the boot may create arcing that could ignite combustible fumes and cause a fire.

Cleaning Air Filter

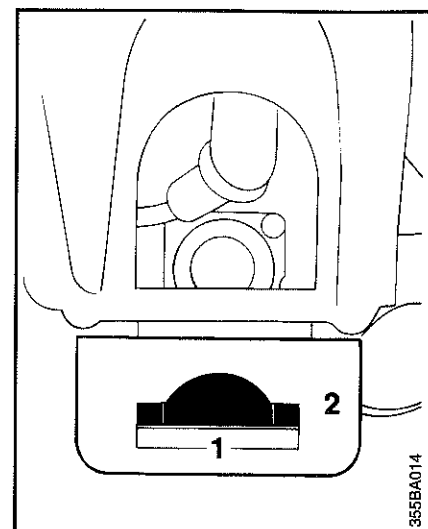

If there is a noticeable loss of engine power:

- Turn choke lever to \overline{I} - Press in the tab (1). Ease the filter cover (2) over the tab and lift it away.
- Clean away dirt from around the filter -

Gearbox Lubrication

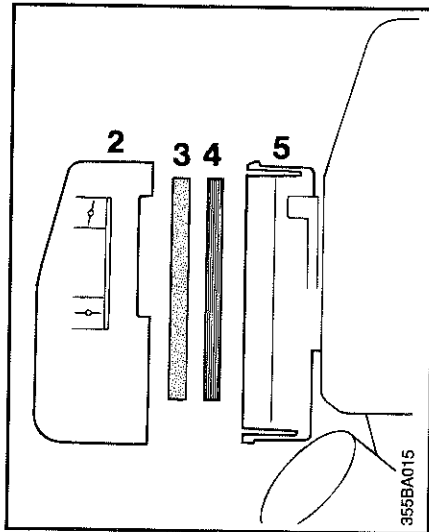

- Remove the foam element (3) and felt element (4).
- Wash the air filter in fresh, non-flammable cleaning solution (e.g. warm soapy water) and then dry.

Always replace a damaged filter element.

- Fit the foam element in the filter cover.
- Fit the felt element in the filter base (5).
- Fit filter cover and engage it in position.

355BA015

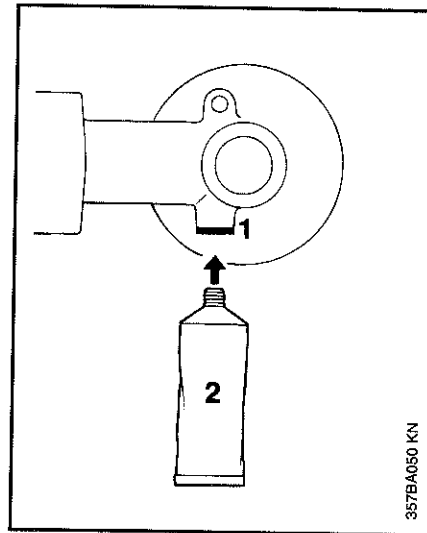

- Check grease level regularly - about every 50 hours of operation. Unscrew the filler plug (1). If no grease can be seen on the inside of the filler plug - Screw the tube (2) of STIHL gear lubricant 0781 120 1117 into the filler hole.
- Squeeze grease into the gear housing - about 5 - 10 g (1/4 oz).

Do not completely fill the gear housing with grease.

- Refit the filler plug and tighten it down firmly.

357BA050 KN

Lubricating Flexible Shaft (FS 74)

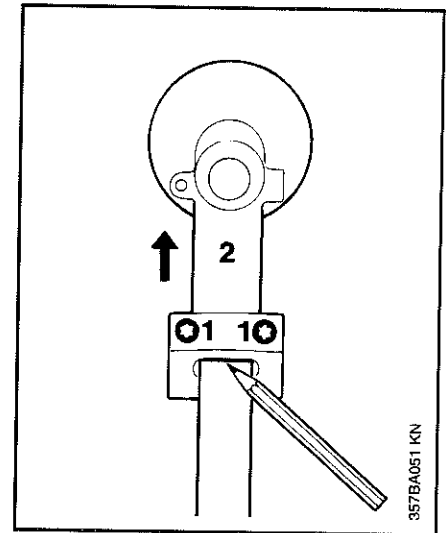

- Check film of lubricant at regular intervals - once weekly if you use your brushcutter daily or every 25 hours of operation if you use your brushcutter occasionally.
- Mark the end of the gear head on the drive tube - Release the clamp screws (1). Pull the gear head (2) off the drive tube.

357BA051 KN

Sharpening Cutting Tools

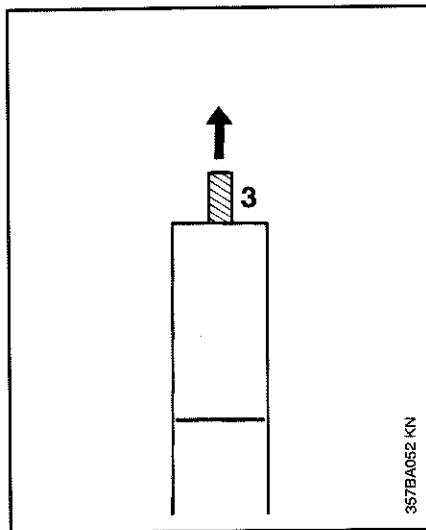

Pull the flexible shaft (3) out of the drive tube.

- Use STIHL multipurpose grease 0781 120 1109 to coat dry areas of the shaft:
Do not apply too much grease - never pump grease into the drive tube.

If shaft has turned blue, fit a new one.

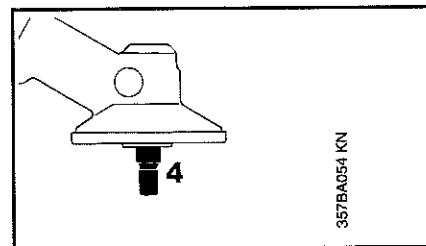
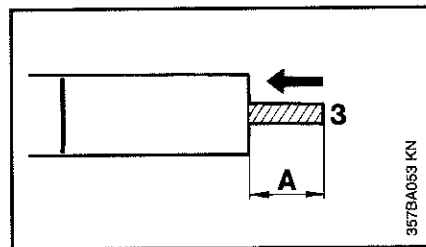

Push shaft (3) into the drive tube - turn it to and fro until distance A is less than 20mm (3/4").

- Slide the drive tube into the gear head - turn drive shaft (4) back and forth until mark is reached.
- Line up the gear head.
- Tighten down the clamp screws.

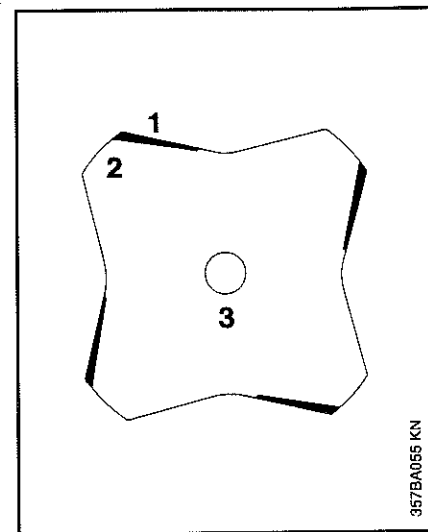

Grass cutting blade 230-4

Never straighten or weld a bent or cracked cutting blade - it might shatter and cause serious or fatal injury.

- Resharpen only when all cutting edges (1) on both sides of the blade are dull: This ensures balanced wear.

To avoid out-of-balance:

Resharpen the cutters (2) uniformly - do not alter the contour of the parent blade (3) in any way.

- After resharpening about 5 times, have blade checked on STIHL balancer 5910 850 2600 and rebalanced as necessary.

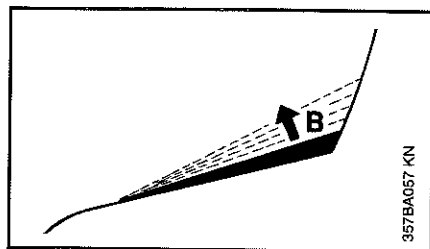
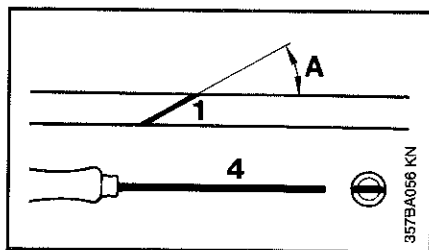

- Sharpen correctly**
- If slightly dull: Use flat file (4) 0814 212 3310 - In case of more serious wear or nicks: Resharpener with a grinder - maintain a sharpening angle of 30° (A) on the cutting edge (1).
 - File back the cutting edge parallel to the lines (B) (see illustration).
 - Resharpener frequently, take away as little material as possible - two or three strokes of the file are usually enough.

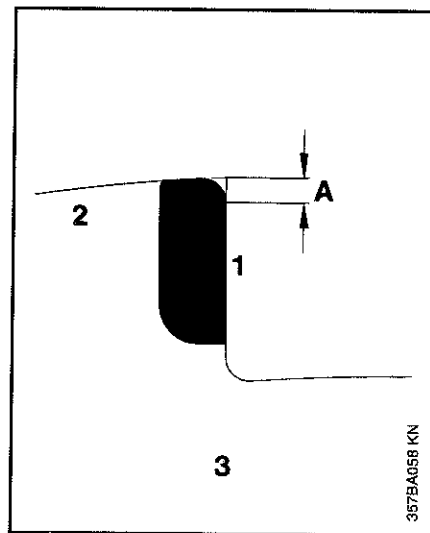

Grass cutting blade 230-8

Never straighten or weld a bent or cracked cutting blade - it might shatter and cause serious or fatal injury.

- Resharpener when the tips of the cutting edges (1) have worn about 1mm/3/64" (A).
- To avoid out-of-balance:**
Resharpener the cutters (2) uniformly - do not alter the contour of the parent blade (3) in any way.
- After resharpener about 5 times, have blade checked on STIHL balancer 5910 850 2600 and rebalanced as necessary.

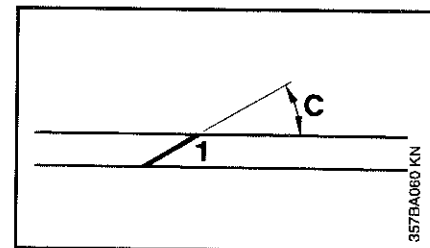
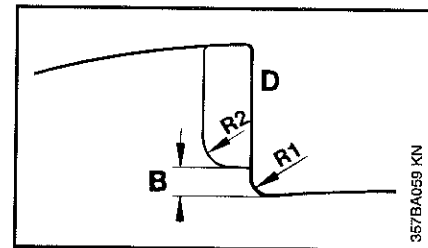

Measurements and angles for resharpener

Leave clearance of 2mm/5/64" (B) between cutting edge and parent blade - R1 should be 2mm/5/64" - Radius R2 is 2.5mm/7/64" and is obtained automatically if you use the specified file and maintain a filing angle of 30° (C). Cutting edge (D) must be exactly in line with center of blade's mounting hole.

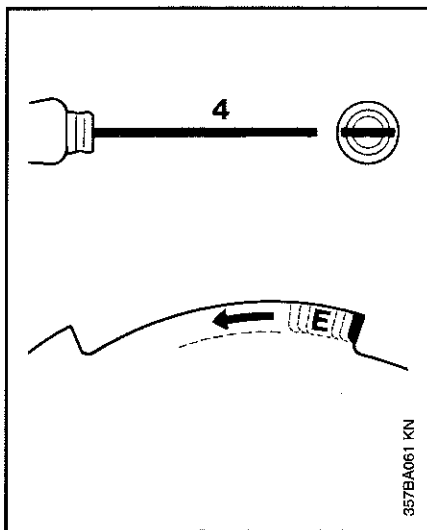

357BA061 KN

Sharpen correctly

- If slightly dull: Use flat file (4) 0814 212 3310 - In case of more serious wear or nicks: Resharpen with a grinder -
- File back the cutting edge parallel to the lines (E) (see illustration).
- Resharpen frequently, take away as little material as possible - two or three strokes of the file are usually enough.

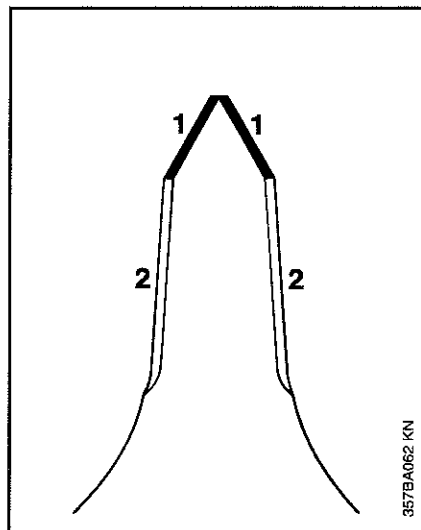

357BA062 KN

Brush knife 250

Never straighten or weld a bent or cracked brush knife - it might shatter and cause serious or fatal injury.

- Only sharpen the cutting edges (1) at the pointed tips - do not sharpen curved cutting edges (2) even if they nicked in places.

To avoid out-of-balance:

- Resharpen cutting edges uniformly - use the sharpening template 0457 342 2629 provided.
- After resharpening about 5 times, have blade checked on

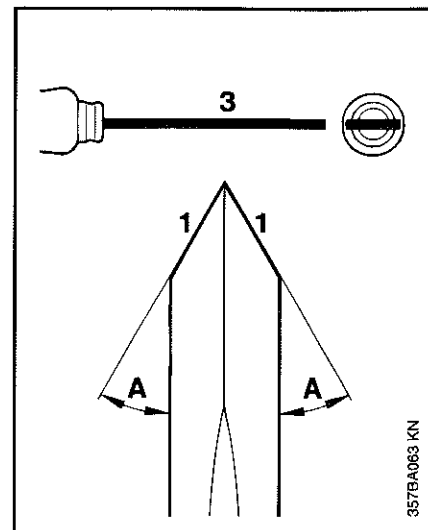

357BA063 KN

STIHL balancer 5910 850 2600 and rebalanced as necessary.

Sharpen correctly

- If slightly dull: Use flat file (3) 0814 212 3310 - In case of more serious wear or nicks: Resharpen with a grinder - maintain a sharpening angle of 30° (A) on the cutting edge (1).
- File back the cutting edge parallel to the lines on the sharpening template.
- Resharpen frequently, take away as little material as possible - two or three strokes of the file are usually enough.

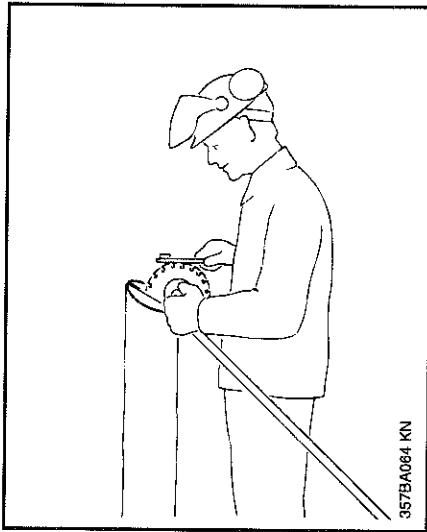

357BA084 KN

Circular saw blade 200 (chisel tooth)

Never straighten or weld a bent or cracked circular saw blade - it might shatter and cause serious or fatal injury.

Sharpening circular saw blade on the unit

- Cut a vertical slit in the top of a tree stump - lean the unit against the stump so that the saw blade rests in the slit.
- Turn the blade with one hand while sharpening - **Wear gloves!**

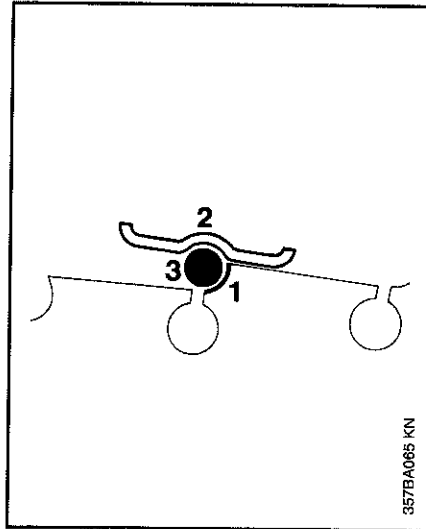

357BA085 KN

Sharpen correctly

- File only the side plate (1).
- If slightly dull: Use file holder (2) 5605 750 4343 and matching 5.5mm dia. round file (3) 0811 411 8108. In case of major or very irregular wear: Use an electric grinder.
- File right and left-hand teeth in the direction of set .

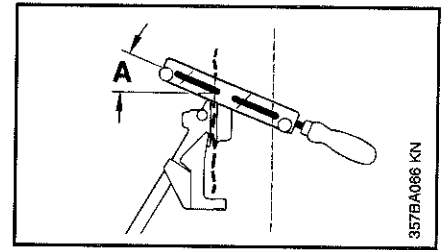

357BA086 KN

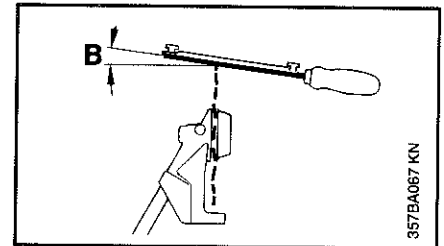

357BA087 KN

- File at the angle marked on the file holder: Filing angle is 15° (A) - file should slope upward at an angle of 5° (B).
- Resharpen frequently, take away as little material as possible - two or three strokes of the file are usually enough.

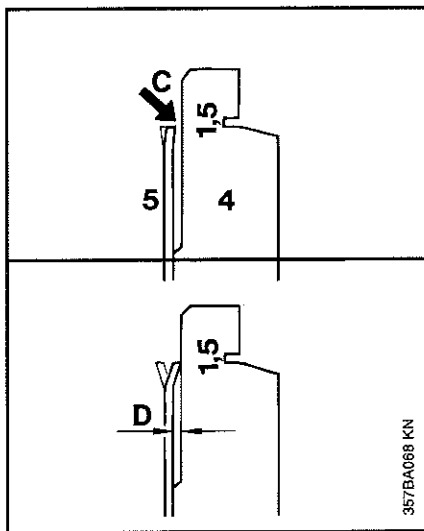

Resetting the teeth

If the saw blade does not cut freely or binds in the cut:

Check set of teeth -

Hold the saw set (4) 4020 893 5000 against the saw blade (5) - if there is a gap (C) between the tooth and saw set: see "Resetting the teeth". If the tooth just touches the saw set: Clearance D is 1mm (3/64") and the set is correct.

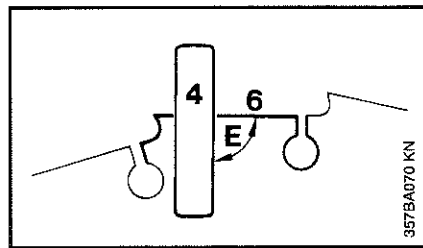
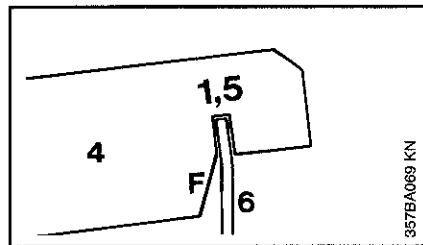

Resetting the teeth

Fit notch of saw set (4) over the tooth (6) - blade thickness 1.5mm (about 1/16"). Maintain the angle of 90° (E) and keep to existing direction of set.

- Push the saw set downward until the sloping side (F) of the notch butts against the saw blade.
- Check set of teeth again.

Circular saw blade 200 (scratcher tooth)

Never straighten or weld a bent or cracked circular saw blade - it might shatter and cause serious or fatal injury.

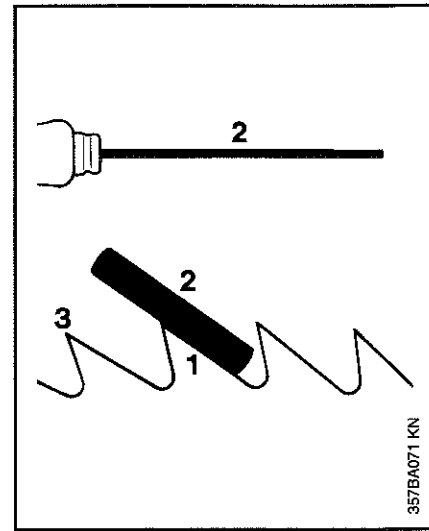

Sharpen correctly

- File only the back of the tooth (1).
- If slightly dull: Use flat file (2) 0814 212 3310 - In case of more serious wear or nicks: Resharpen with a grinder - until the tips (3) of the teeth are restored to full sharpness.
- Resharpen frequently, take away as little material as possible - two or three strokes of the file are usually enough. Do not alter tooth profile.

Replacing Starter Rope and Rewind Spring

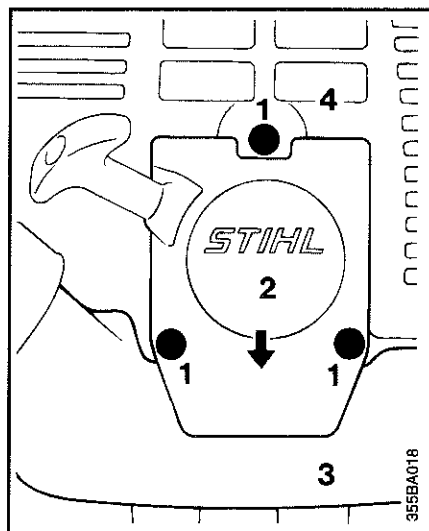

Remove the three screws (1). Lift the starter cover (2) off the tank (3) and pull it out under the shroud (4).

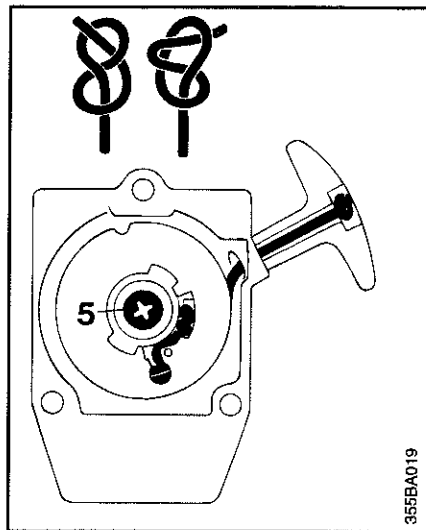

- Take out the screw (5).
- Remove the rope rotor very carefully - the rewind spring is seated in the rope rotor and may pop out and uncoil if care is not taken.
- Remove remaining rope from rotor - thread the new rope - 3mm x 900mm (1/8" dia. x 35 1/2") - into the rotor and secure it with a simple overhand knot. Thread other end - from inside - through the rope guide bush and the underside of the starter grip and secure with special knot - do not wind rope onto rotor.

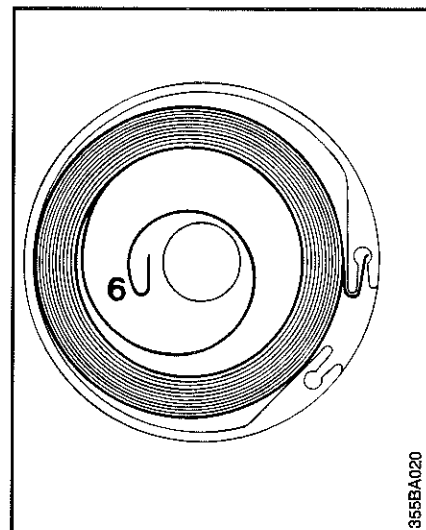

- Coat rope rotor bearing bore with non-resinous oil.
- Slide rotor onto starter post - turn it back and forth until anchor loop (6) of rewind spring engages.
- Fit screw and tighten down firmly.

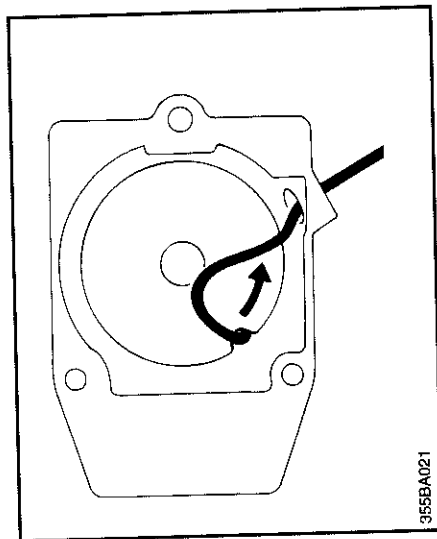

Tensioning rewind spring

- Make a loop in the starter rope and use it to turn the rope rotor five full revolutions counterclockwise. Hold the rotor steady - straighten the twisted rope - release the rotor - let go of rope slowly so that it winds onto the rotor.

The starter grip must be firmly seated in the rope guide bush. If grip droops to one side: Add one more turn on rope rotor to increase spring tension.

355BA021

When starter rope is fully extended it must be possible to rotate the rotor another two turns. If this is not the case, the spring is overtensioned and could break. Take one turn of rope off the rotor.

Replacing a broken rewind spring

- Lubricate the new spring with a drop of non-resinous oil - do not open the wire retainer.

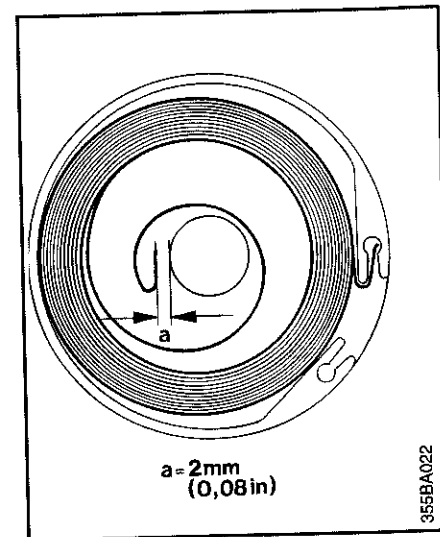

a = 2mm
(0,08 in)

355BA022

- Remove the rope rotor.
- Remove parts of old spring.
- Fit the new spring - position outer spring loop in the recess - the wire retainer slips off in this process.
- Install the rope rotor.
- Tension the rewind spring.
- Fit the starter cover - locate upper mounting boss under the shroud - align tank - lower part of cover locates against tank.

If the spring has popped out: Refit it in the counterclockwise direction - starting outside and working inward.

Operating Instructions

During break-in period

A factory new machine should not be run at high revs (full throttle off load) for the first three tank fillings. This avoids unnecessary high loads during the break-in period.

As all moving parts have to bed in during the break-in period, the frictional resistances in the engine are greater during this period. The engine develops its maximum power after about 5 to 15 tank fillings.

During operation

After long period of full-throttle operation, allow engine to run for a while at idling speed so that the heat in the engine can be dissipated by flow of cooling air. This protects engine-mounted components (ignition, carburetor) from thermal overload.

After finishing work

Storing for short period :
To avoid condensation, fill the fuel tank and keep the unit in a dry place until you need it again.

Storing for a long period:
Drain and clean the fuel tank - run engine until carburetor is dry.

Check tightness of nuts and screws (not adjusting screws) at regular intervals and retighten as necessary.

Spark Arresting Screen in Muffler

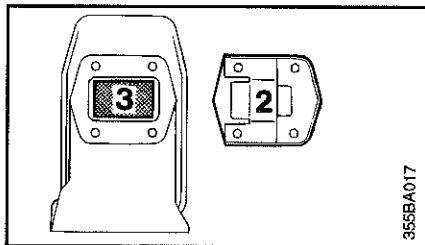
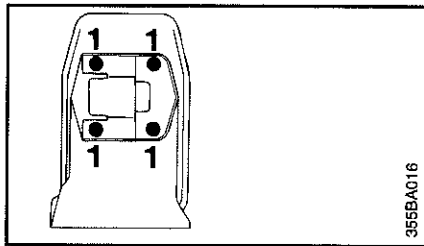

If the engine is low on power, check the spark arresting screen inside the muffler.

- Remove the shroud.
Take out the screws (1).
Remove the cover (2).
Remove the spark arresting screen (3).
- Clean spark arresting screen if necessary.
- If screen is damaged or coked up, fit a new one.
- Refit the spark arresting screen.
- Fit the cover.

Storing the Machine

For periods of about 3 months or longer:

- Drain and clean the fuel tank.
- Run engine until carburetor is dry - this helps prevent the carburetor diaphragms sticking together.
- Remove, clean and inspect the cutting tool.
- Thoroughly clean the machine - pay special attention to the cylinder fins and air filter.
- Store the machine in a dry, high or locked location - out of the reach of children and other unauthorized persons.

Maintenance Chart

Please note that the following maintenance intervals apply for normal operating conditions only. If your daily working time is longer than normal or operating conditions are difficult (very dusty work area resinous growth etc.), shorten the specified intervals accordingly		before starting work	after finishing work or daily	after each refueling stop	weekly	monthly	if faulty	if damaged	as required	see page:
Complete machine	Visual inspection (condition leaks)	x		x						
	Clean		x							
Throttle trigger, slide control	Check operation	x		x						
Air filter	Clean						x		x	42-43
	Replace							x		42-43
Filter in fuel tank	Check						x			33
	Replace							x	x	33
Fuel tank	Clean					x				32
Carburetor	Check idle setting - cutting tool must not turn	x		x						39-41
	Readjust idle								x	39-41
Spark plug	Readjust electrode gap						x			42
Cylinder fins	Clean				x					52
Spark arresting screen in muffler	Inspect		x							52
	Clean or replace								x	52
All accessible screws and nuts (not adjusting screws)	Retighten								x	
Cutting tool	Visual inspection	x		x						24-31
	Replace							x	x	24-31
	Check tightness of cutting tool	x								24-31
Gearbox lubrication	Check				x					43
	Top up								x	43
Flexible drive shaft (FS 74)	Check lubrication				x					43-44
	Complete lubrication								x	43-44

Specifications

The user of the brushcutter may carry out only the maintenance operations described in this manual. Other repair work may be performed only by an authorized STIHL Service Shop.

Warranty claims following repairs can be accepted only if the repair has been performed by an authorized STIHL Service Shop using original STIHL spare parts.

Original STIHL parts can be identified by the STIHL part number, the **STIHL** logo and the STIHL parts symbol . The symbol may appear alone on small parts.

Engine

Single cylinder two-stroke engine
Displacement: 23.9 cm³
(1.46 cu.in)
Bore: 33 mm (1.30 in)
Stroke: 28 mm (1.10 in)
Engine power to
ISO 8893: 0.8 kW (1,1 bhp)
Max. output shaft speed
(tool mounting)
FS 74 / 74 R: 8500 rpm
FS 76 / 76 R: 7700 rpm
Idle speed: 2800 rpm
Max. engine speed:
As described under "Adjusting
carburetor"

Ignition System

Type:
Electronic magneto ignition
Ignition timing:
Spark plug
(suppressed): Bosch WSR 6 F
or
NGK BPMR 7A;
Heat range 200
Electrode gap: 0.5 mm (0.02 in)
Spark plug thread: M 14 x 1.25;
9.5 mm
(0.37 in) long

Fuel System

Carburetor:
All position diaphragm carburetor
with integral fuel pump

Air filter:
Foam and felt elements

Fuel tank capacity:
0.42 l (0.9 US pt)

Fuel mix:
see chapter "Fuel"

Weights

without cutting tool and deflector:

FS 74
with loop handle 5.2 kg 11.5 lbs

FS 74
with handlebar 5.6 kg 12.3 lbs

FS 76
with loop handle 4.9 kg 10.8 lbs

FS 76
with handlebar 5.3 kg 11.7 lbs

Model	Tool	Sound pressure level L_{peq} to ISO 7917 ¹⁾	Sound power level L_{weq} to ISO 10884 ¹⁾	Vibration acceleration to ISO 7916		Vibration acceleration to ISO 7916	
		dB (A)	dB (A)	Idle speed (m/s^2)	Handle	Max. RPM (m/s^2)	Handle
				right	left	right	left
FS 74 ²⁾	Mowing head	97	108	1.1	1.4	2.4	2.5
FS 74 ²⁾	Metaltool	92	105	1.1	1.4	2.6	2.9
FS 74 R ³⁾	Mowing head	97	108	2.0	2.7	4.9	5.1
FS 74 R ⁴⁾	Metaltool	92	105	2.4	2.3	7.0	4.7
FS 76 ²⁾	Mowing head	95	108	1.0	0.9	4.7	5.9
FS 76 ²⁾	Metaltool	93	105	1.0	0.9	2.8	2.7
FS 76 R ³⁾	Mowing head	95	108	0.9	1.5	7.9	7.2
FS 76 R ⁴⁾	Metaltool	93	105	0.9	1.5	8.2	5.6

- 1) Weighted equivalent level includes idling and maximum RPM with the same duration of exposure
- 2) Version with bike handle
- 3) Version with loop handle
- 4) Version with loop handle with standoff lever

Special Accessories

Cutting tools

- | | |
|--|--|
| <p>1 STIHL "Supercut 20-1" mowing head
4002 710 2160 (FS 74 only)</p> <p>2 STIHL "Supercut 20-2" mowing head
4002 710 2162</p> <p>3 STIHL "Autocut 20-2" mowing head
4002 710 2106 (FS 74 only)</p> <p>4 STIHL "Autocut 24-2" mowing head
4002 710 2109</p> <p>5 STIHL "Autocut 25-2" mowing head
4002 710 2108</p> <p>6 STIHL "Autocut 30-2" mowing head
4002 710 2107</p> <p>7 STIHL "Polymatic 30-2" mowing head
4002 710 2120</p> <p>8 STIHL "Polycut 20-3" mowing head
4002 710 2130</p> <p>9 STIHL "Fixed Line Head"
4001 413 2100</p> <p>10 Grass Cutting blade 230-4*
4001 713 3801</p> <p>11 Grass Cutting blade 230-8*
4001 713 3803</p> <p>12 Brush knife 250 -3*
4112 713 4100</p> | <p>13 Circular saw blade 200
(scratcher tooth)**
4112 713 4201</p> <p>14 Circular saw blade 200
(chisel tooth)**
4112 713 4203</p> |
|--|--|
- * Not approved for FS 74 and FS 76
with loop handle **without** standoff
lever.
- ** Not approved for FS 74 and FS 76
with loop handle.

Other special accessories

Nylon line for mowing heads

2.0 mm/0.08" diameter / green:

15 m/50 ft	0000 930 2217
372 m/1220 ft	0000 930 2263
620 m/2035 ft	0000 930 2264

for 3

2.4 mm/0.095" diameter / orange:

15 m/50 ft	0000 930 2243
44 m/143 ft	0000 930 2244
87 m/285 ft	0000 930 2245
261 m/855 ft	0000 930 2246
434 m/1425 ft	0000 930 2247

for 1 to 9

2.7 mm/0.105" diameter / red:

10.7 m/35 ft	0000 930 2218
72 m/235 ft	0000 930 2224

for 8 and 9

Thermoplastic blades for Polycut 20-3

Pack of 12	4111 007 1001
------------	---------------

Transport guard for
cutting blade 4116 790 3906

Transport guard for brush knife and
circular saw blade 4112 790 3901

Full harness

Safety goggles

STIHL multipurpose grease
(80 g/3 oz tube) 0781 120 1109

(225 g/8 oz tube) 0781 120 1110

STIHL gear lubricant
(80 g/3 oz tube) 0781 120 1117

(225 g/8 oz tube) 0781 120 1119

 **WARNING!**

The engine exhaust from this product contains chemicals known to the State of California to cause cancer, birth defects or other reproductive harm.

englisch/englisch U.S.A.