



Residential Products

---

---

# Walk Power Mower Drive Systems Service Manual





# ABOUT THIS MANUAL

---

This service manual was written expressly for Toro and Lawn-Boy service technicians. The Toro Company has made every effort to make the information in this manual complete and correct.

Basic shop safety knowledge and mechanical/electrical skills are assumed. The Table of Contents lists the systems and the related topics covered in this manual.

This manual contains material covering Toro and Lawn-Boy Walk Behind Mower Drive Systems with models ranging from 1990 through 2013. The manual may also be specified for use on later model products of similar design. For information specific to the engines used on these models, refer to the appropriate engine manufacturer's service and repair instructions.

Due to the compact design, parts may have been removed for photographic purposes when necessary.

We are hopeful that you will find this manual a valuable addition to your service shop. If you have any questions or comments regarding this manual, please contact us at the following address:

**The Toro Company  
Residential and Landscape Contractor Service Training Department  
8111 Lyndale Avenue South  
Bloomington, MN 55420**

The Toro Company reserves the right to change product specifications or this manual without notice.

**THIS PAGE INTENTIONALLY LEFT BLANK.**

# TABLE OF CONTENTS

## 1 - Safety Information

General Information.....	1-2
Think Safety First.....	1-2

## 2 - Worm Drive Transmission

GENERAL .....	2-2
INTERNALLY CLUTCHED .....	2-2
Description .....	2-2
Lubrication .....	2-3
The Shifting Process.....	2-3
Removal & Installation (front wheel drive applications) .....	2-4
Disassembly.....	2-5
Assembly .....	2-8
Controls.....	2-10
Adjustment .....	2-10
CONSTANT MESH.....	2-11
Description .....	2-11
Removal and Installation.....	2-12
Controls.....	2-13
WHEEL CLUTCH .....	2-13

## 3 - Single Speed Spur/Bevel Gear Transmission

GEAR CASE ASSEMBLY.....	3-2
Description .....	3-3
Lubrication .....	3-3
Transmission Removal and Replacement .....	3-3
Transmission Internal Repair .....	3-4
Assembly .....	3-6

## 4 - Single Speed Bevel Gear Transmission

EXPLODED VIEW - SINGLE SPEED BEVEL GEAR TRANSMISSION .....	4-2
GENERAL INFORMATION.....	4-3
FRONT AXLE AND TRANSMISSION ASSEMBLY.....	4-4
22" FRONT WHEEL DRIVE MODELS .....	4-5
Remove Transmission .....	4-5
Transmission Disassembly .....	4-7
Transmission Assembly .....	4-7
Assembly Tips.....	4-8
Belt Service - Front Wheel Drive Models .....	4-9
22" TORO & LAWN-BOY REAR WHEEL DRIVE MODELS.....	4-10
Transmission Removal and Belt Replacement .....	4-10
Rear Axle Disassembly .....	4-15
Transmission Disassembly .....	4-16
Transmission Assembly .....	4-16
Axle Assembly Tips .....	4-17

# TABLE OF CONTENTS

---

## 4 - Single Speed Bevel Gear Transmission cont.

LAWN-BOY INSIGHT TRANSMISSION REMOVE AND REPLACE .....	4-19
Transmission Removal & Belt Replacement .....	4-20
Transmission Disassembly .....	4-24
Transmission Assembly & Installation .....	4-24
Axle Assembly Tips .....	4-24
Transmission Installation Tips .....	4-25

## 5 - Three Speed Transmission

GEAR CASE ASSEMBLY .....	5-2
OPERATION .....	5-3
Removal - Toro Vacu Power/Lawn-Boy Medallion Models .....	5-5
Removal - Recycler/Rear Bagger Chassis .....	5-6
Alternate Method .....	5-6
Disassembly .....	5-6
Transmission - Assembly .....	5-8
Output Shaft Assembly .....	5-8
Input Shaft Assembly .....	5-9
Intermediate Shaft Assembly .....	5-10
Installation .....	5-10
Special Assembly Notes for Toro Vacu Power/Lawn-Boy Medallion .....	5-11
TROUBLESHOOTING TIPS - 3 SPEED TRANSMISSION .....	5-12
Hard Shifting .....	5-12
Slipping Gears .....	5-12

## 6 - General Transmissions®

General Information .....	6-2
22" Steel Deck - Rear Axle and Transmission Assembly .....	6-3
22" Steel Deck - Rear Axle Belt Replacement .....	6-4
22" Steel Deck - Rear Axle Transmission Replacement .....	6-6
22" Steel Deck - Front Axle and Transmission Assembly .....	6-7
22" Steel Deck - Front Axle Belt Replacement .....	6-8
22" Steel Deck - Front Axle Transmission Replacement .....	6-9
21" Steel Deck - Rear Axle and Transmission Assembly .....	6-10
21" Steel Deck - Rear Axle Belt Replacement .....	6-11
21" Steel Deck - Rear Axle Transmission Replacement .....	6-12
Cast Deck - Rear Axle and Transmission Assembly .....	6-13
Cast Deck - Rear Axle Belt Replacement .....	6-14
Cast Deck - Rear Axle Transmission Replacement .....	6-15

## 7 - Wheel Pinion Clutch

GEAR CASE AND WHEEL ASSEMBLY, ROCKING KEY STYLE .....	7-2
Wheel Pinion Clutch .....	7-3
Component Definitions .....	7-3
Test for Function .....	7-4
Quick Test .....	7-4
Rear Height-of-Cut and Wheel Pinion Clutch - Disassembly .....	7-4
Rear Height-of-Cut and Wheel Pinion Clutch - Assembly .....	7-5

# TABLE OF CONTENTS

## 7 - Wheel Pinion Clutch cont.

GEAR CASE AND WHEEL ASSEMBLY, SPRING RATCHET STYLE .....	7-8
Spring Ratchet Style .....	7-9
Servicing the System .....	7-9
WHEEL PINION SERVICE .....	7-9

## 8 - BBC / BOS / BCS

BLADE BRAKE CLUTCH SYSTEM (BBC) .....	8-2
Description .....	8-2
BBC Clutch Operation .....	8-2
BBC Control Box Operation .....	8-2
Handle Controls .....	8-3
Control Box Disassembly .....	8-6
Control Box Assembly .....	8-7
TORO BBC SERVICE GUIDE .....	8-10
BLADE BRAKE CLUTCH ASSEMBLY (Toro Vacu Power/Lawn-Boy Medallion BBC) .....	8-11
TORO VACU POWER/LAWN-BOY MEDALLION BBC .....	8-12
Bellcrank System Disassembly (Toro Vacu Power/Lawn-Boy Medallion) .....	8-12
Bellcrank System Assembly (Toro Vacu Power/Lawn-Boy Medallion) .....	8-13
Under Deck Components Disassembly (Toro Vacu Power/Lawn-Boy Medallion) .....	8-15
Under Deck Components Assembly (Toro Vacu Power/Lawn-Boy Medallion) .....	8-17
BBC Cable Removal (Toro Vacu Power/Lawn-Boy Medallion) .....	8-19
BBC Cable Installation (Toro Vacu Power/Lawn-Boy Medallion) .....	8-20
ENGINE AND BLADE ASSEMBLY (Toro Recycler / Rear Bagger) .....	8-21
TORO RECYCLER/REAR BAGGER BBC .....	8-22
Idler Arm System Disassembly (Recycler/Rear Bagger) .....	8-22
Idler Arm System Assembly (Recycler/Rear Bagger) .....	8-25
BBC Cable Removal (Recycler/Rear Bagger) .....	8-28
BBC Cable Installation (Recycler/Rear Bagger) .....	8-29
BLADE OVERRIDE SYSTEM (BOS) .....	8-29
BLADE CLUTCH SYSTEM (BCS) .....	8-29
Disassembly .....	8-29
Brake Arm Assembly .....	8-33
BOS/BCS System Assembly .....	8-34

## 9 - Handles & Control Cables

Toro 2 Bail Handle .....	9-2
Personal Pace Generation 1/Easy Stride Generation 1 .....	9-3
Operation .....	9-3
Disassembly .....	9-3
Reassembly .....	9-5
Adjusting the Personal Pace Cable .....	9-6
Personal Pace Generation 2/Easy Stride Generation 2 .....	9-6
Disassembly .....	9-6
Adjusting the Personal Pace/Easy Stride Cable .....	9-8
Lawn-Boy 2 Bail Handle .....	9-8

# TABLE OF CONTENTS

---

## 9 - Handles & Control Cables cont.

Lawn-Boy Sens-a-Speed.....	9-9
Operation .....	9-9
Handle Disassembly, Zone Start Models .....	9-9
Assembly .....	9-10
Cable Adjustment.....	9-11
Self-Propel Cable.....	9-11
Handle Disassembly, Lawn-Boy Blade Clutch System (BCS) Models .....	9-11
3 Speed Transmission Models .....	9-13
3 Speed Control Cables.....	9-13
BBC Cable Adjustment (Toro Vacu Power/Lawn-Boy Medallion).....	9-14
Toro BBC Cable Adjustment (Recycler/Rear Bagger).....	9-16
Toro BOS Control .....	9-17
Toro BOS Control Cable Adjustment.....	9-17
Lawn-Boy BCS Control.....	9-18
Lawn-Boy BCS Control Cable Adjustment.....	9-18

## 10 - Self-Propel Belt Replacement

Toro 21" Front Wheel Drive – Worm Drive Transmission .....	10-2
21" Steel & Cast Deck – Single Speed Spur/Bevel Gear Transmission .....	10-2
22" Front Wheel Drive – Single Speed Bevel Gear Transmission.....	10-2
22" Rear Wheel Drive – Single Speed Bevel Gear Transmission .....	10-2
21" Lawn-Boy Insight Mowers .....	10-2
21" Cast Deck Mowers – 3 Speed Transmission.....	10-3
20", 21", 22", 48cm, 50cm, & 53cm Steel & Cast Deck – General Transmission .....	10-3
21" Toro & Lawn-Boy Mowers with Blade Brake Clutch .....	10-3
21" Toro Mowers with Blade Override System (BOS) & Lawn-Boy Mower w/Blade Clutch System (BCS) ..	10-3



# USING THIS MANUAL

Following each model number in the list below are codes identifying the type of deck material, transmission, wheel pinion clutch, hand controls, and blade clutch system if applicable. Use this information to select the correct service manual section for the mower being serviced.

## Code List

1B – one bail	ADS – Automatic Drive System
2B – two bail	ES1 – Easy Stride 1st generation
3S – 3-speed	ES2 – Easy Stride 2nd generation
20stl – 20" steel deck	PP1 – Personal Pace 1st generation
21stl – 21" steel deck	PP2 – Personal Pace 2nd generation
22stl – 22" steel deck	B – bevel gear
BBC – blade brake clutch	RK – rocking key
BBC VP – blade brake clutch for Vacu-Power	SB – spur bevel
BOS – blade override system	SR – spring ratchet
CD – cast deck	SS – Sens-a-Speed
CDVP – cast deck Vacu-Power	W – worm
INS – Insight	NS – not serviceable

Model	Trans R&R	Trans Internal Repair	Wheel Pinion	Handle Repair	Blade Clutch
10301	CD	SB	RK	2B	None
10302	CD	SB	RK	2B	None
10304	CD	SB	RK	2B	None
10305	CD	SB	RK	2B	None
10307	CD	SB	RK	2B	None
10309	CD	SB	RK	2B	None
10310	CD	SB	RK	2B	None
10311	CD	SB	RK	2B	None
10312	CD	SB	RK	2B	None
10313	CD	SB	RK	2B	None
10314	CD	SB	RK	2B	None
10316	CD	SB	RK	2B	None
10317	CD	SB	RK	2B	None
10318	CD	SB	RK	2B	None
10319	CD	SB	RK	2B	None
10320	CD	SB	RK	2B	None
10321	CD	SB	RK	2B	None
10323	CD	SB	RK	2B	None
10324	CD	SB	RK	2B	None
10324C	CD	SB	RK	2B	None
10327	CD	SB	RK	2B	None
10328	CD	SB	RK	2B	None
10329	CD	SB	RK	2B	None

# USING THIS MANUAL

## Code List

1B – one bail	ADS – Automatic Drive System
2B – two bail	ES1 – Easy Stride 1st generation
3S – 3-speed	ES2 – Easy Stride 2nd generation
20stl – 20” steel deck	PP1 – Personal Pace 1st generation
21stl – 21” steel deck	PP2 – Personal Pace 2nd generation
22stl – 22” steel deck	B – bevel gear
BBC – blade brake clutch	RK – rocking key
BBC VP – blade brake clutch for Vacu-Power	SB – spur bevel
BOS – blade override system	SR – spring ratchet
CD – cast deck	SS – Sens-a-Speed
CDVP – cast deck Vacu-Power	W – worm
INS – Insight	NS – not serviceable

Model	Trans R&R	Trans Internal Repair	Wheel Pinion	Handle Repair	Blade Clutch
10330	CD	SB	RK	2B	None
10331	CD	SB	RK	2B	None
10332	CD	SB	RK	2B	None
10334	CD	SB	RK	2B	None
10335	CD	SB	RK	2B	None
10342	CD	SB	RK	2B	None
10343	CD	SB	RK	2B	None
10344	CD	SB	RK	2B	None
10345	CD	SB	RK	2B	None
10356	CD	SB	RK	2B	None
10357	CD	SB	RK	2B	None
10358	CD	SB	RK	2B	None
10359C	CD	SB	RK	2B	None
10360	CD	SB	RK	2B	None
10360C	CD	SB	RK	2B	None
10361	CD	SB	RK	2B	None
10362	CD	SB	RK	2B	None
10363	CD	SB	RK	2B	None
10515	CD	3S	RK	2B	None
10516	CD	3S	RK	2B	None
10517	CD	3S	RK	2B	None
10518	CD	3S	RK	2B	None
10519	CD	3S	RK	2B	None
10520	CD	3S	RK	2B	None
10521	CD	3S	RK	2B	None
10522	CD	3S	RK	2B	None
10523	CD	3S	RK	2B	None

# USING THIS MANUAL

## Code List

1B – one bail	ADS – Automatic Drive System
2B – two bail	ES1 – Easy Stride 1st generation
3S – 3-speed	ES2 – Easy Stride 2nd generation
20stl – 20” steel deck	PP1 – Personal Pace 1st generation
21stl – 21” steel deck	PP2 – Personal Pace 2nd generation
22stl – 22” steel deck	B – bevel gear
BBC – blade brake clutch	RK – rocking key
BBC VP – blade brake clutch for Vacu-Power	SB – spur bevel
BOS – blade override system	SR – spring ratchet
CD – cast deck	SS – Sens-a-Speed
CDVP – cast deck Vacu-Power	W – worm
INS – Insight	NS – not serviceable

Model	Trans R&R	Trans Internal Repair	Wheel Pinion	Handle Repair	Blade Clutch
10524	CD	3S	RK	2B	None
10525	CD	3S	RK	2B	None
10527	CD	3S	RK	2B	None
10528	CD	3S	RK	2B	None
10533	CD	3S	RK	1B	BBC VP
10545	CD	3S	RK	2B	None
10546	CD	3S	RK	2B	None
10547	CD	3S	RK	2B	None
10548	CD	3S	RK	2B	None
10550	CD	SB	RK	ES1	None
10551	CD	SB	RK	ES1	None
10552	CD	SB	RK	ES1	None
10604	20stl	NS	None	2B	None
10605	20stl	NS	None	2B	BBC
10606	20stl	NS	None	2B	None
10607	20stl	NS	None	SS	None
10624	20stl	NS	None	2B	None
10625	20stl	NS	None	2B	BBC
10627	20stl	NS	None	SS	None
10632	20stl	NS	None	2B	None
10634	20stl	NS	None	2B	None
10641	20stl	NS	None	2B	None
10641C	20stl	NS	None	2B	None
10642	20stl	NS	None	2B	None
10642C	20stl	NS	None	2B	None
10644C	20stl	NS	None	2B	None
10646	20stl	NS	None	2B	None

# USING THIS MANUAL

## Code List

1B – one bail	ADS – Automatic Drive System
2B – two bail	ES1 – Easy Stride 1st generation
3S – 3-speed	ES2 – Easy Stride 2nd generation
20stl – 20" steel deck	PP1 – Personal Pace 1st generation
21stl – 21" steel deck	PP2 – Personal Pace 2nd generation
22stl – 22" steel deck	B – bevel gear
BBC – blade brake clutch	RK – rocking key
BBC VP – blade brake clutch for Vacu-Power	SB – spur bevel
BOS – blade override system	SR – spring ratchet
CD – cast deck	SS – Sens-a-Speed
CDVP – cast deck Vacu-Power	W – worm
INS – Insight	NS – not serviceable

Model	Trans R&R	Trans Internal Repair	Wheel Pinion	Handle Repair	Blade Clutch
10647	20stl	NS	None	2B	None
10649C	20stl	NS	None	2B	None
10650C	20stl	NS	None	2B	None
10655	22stl	B	SR	ES2	None
10656	22stl	B	SR	ES2	None
10658	20stl	NS	None	2B	BBC
10662	21stl	NS	None	2B	None
10684C	21stl	NS	None	2B	None
10665	21stl	NS	None	SS	None
10665C	21stl	NS	None	SS	None
10666	21stl	NS	None	SS	None
10666C	21stl	NS	None	SS	None
10672	INS	B	SR	SS	None
10673	INS	B	SR	SS	None
10682	INS	B	SR	2B	None
10684	INS	B	SR	2B	None
10684C	INS	B	SR	2B	None
10685	INS	B	SR	SS	None
10686	INS	B	SR	SS	None
10686C	INS	B	SR	SS	None
10687	INS	B	SR	SS	BCS
10695	INS	B	SR	SS	None
10696	INS	B	SR	SS	None
10696C	INS	B	SR	SS	None
10697	INS	B	SR	SS	BCS
10765	CD	NS	None	SS	None
10780	CD	NS	None	2B	None

# USING THIS MANUAL

## Code List

1B – one bail	ADS – Automatic Drive System
2B – two bail	ES1 – Easy Stride 1st generation
3S – 3-speed	ES2 – Easy Stride 2nd generation
20stl – 20” steel deck	PP1 – Personal Pace 1st generation
21stl – 21” steel deck	PP2 – Personal Pace 2nd generation
22stl – 22” steel deck	B – bevel gear
BBC – blade brake clutch	RK – rocking key
BBC VP – blade brake clutch for Vacu-Power	SB – spur bevel
BOS – blade override system	SR – spring ratchet
CD – cast deck	SS – Sens-a-Speed
CDVP – cast deck Vacu-Power	W – worm
INS – Insight	NS – not serviceable

Model	Trans R&R	Trans Internal Repair	Wheel Pinion	Handle Repair	Blade Clutch
10785	CD	NS	None	SS	None
10795	CD	NS	None	SS	None
10796	CD	NS	None	SS	None
10797	CD	NS	None	SS	BBC
10910	CD	SB	RK	2B	None
10910B	CD	SB	RK	2B	None
10926	CD	SB	RK	2B	None
10927	CD	SB	RK	2B	None
10928	CD	3S	RK	1B	None
10929	CD	SB	RK	2B	None
10995	INS	B	SR	SS	None
10996	21stl	NS	None	SS	None
10997	21stl	NS	None	SS	None
10998	21stl	NS	None	SS	None
11001	CD	3S	RK	2B	None
11001B	CD	3S	RK	2B	None
11003	CD	3S	RK	2B	None
16212	W	Worm	None	None	None
16212B	W	Worm	None	None	None
16212W	W	Worm	None	None	None
16212WG	W	Worm	None	None	None
16401	W	Worm	None	None	None
16402	W	Worm	None	None	None
16404	W	Worm	None	None	None
16411	W	Worm	None	None	None
16775	W	Worm	None	None	None
16776	W	Worm	None	None	None

# USING THIS MANUAL

## Code List

1B – one bail	ADS – Automatic Drive System
2B – two bail	ES1 – Easy Stride 1st generation
3S – 3-speed	ES2 – Easy Stride 2nd generation
20stl – 20” steel deck	PP1 – Personal Pace 1st generation
21stl – 21” steel deck	PP2 – Personal Pace 2nd generation
22stl – 22” steel deck	B – bevel gear
BBC – blade brake clutch	RK – rocking key
BBC VP – blade brake clutch for Vacu-Power	SB – spur bevel
BOS – blade override system	SR – spring ratchet
CD – cast deck	SS – Sens-a-Speed
CDVP – cast deck Vacu-Power	W – worm
INS – Insight	NS – not serviceable

Model	Trans R&R	Trans Internal Repair	Wheel Pinion	Handle Repair	Blade Clutch
16785	W	Worm	None	None	None
16793	W	Worm	None	None	None
20001	22stl	B	SR	2B	None
20003	22stl	B	SR	2B	None
20005	22stl	B	SR	2B	None
20007	22stl	B	SR	2B	None
20011	22stl	SB	RK	2B	None
20012	22stl	B	SR	2B	None
20013	22stl	B	SR	PP2	None
20014	22stl	B	SR	PP2	None
20016	22stl	B	SR	2B	None
20017	22stl	B	SR	PP2	None
20018	22stl	B	SR	PP2	None
20019	22stl	B	SR	2B	None
20020	CD	SB	RK	2B	None
20021	CD	SB	RK	2B	None
20028	CD	SB	RK	2B	None
20031	22stl	B	SR	PP2	None
20036	CD	SB	RK	PP2	None
20037	CD	SB	RK	PP2	None
20038	CD	SB	RK	PP2	None
20039	CD	SB	RK	PP2	None
20041	22stl	B	SR	PP2	None
20044	CD	3SP	RK	1B	None
20047	22stl	B	RK	PP2	None
20049	22stl	B	SR	PP2	None
20051	22stl	B	SR	PP2	None

# USING THIS MANUAL

## Code List

1B – one bail	ADS – Automatic Drive System
2B – two bail	ES1 – Easy Stride 1st generation
3S – 3-speed	ES2 – Easy Stride 2nd generation
20stl – 20" steel deck	PP1 – Personal Pace 1st generation
21stl – 21" steel deck	PP2 – Personal Pace 2nd generation
22stl – 22" steel deck	B – bevel gear
BBC – blade brake clutch	RK – rocking key
BBC VP – blade brake clutch for Vacu-Power	SB – spur bevel
BOS – blade override system	SR – spring ratchet
CD – cast deck	SS – Sens-a-Speed
CDVP – cast deck Vacu-Power	W – worm
INS – Insight	NS – not serviceable

Model	Trans R&R	Trans Internal Repair	Wheel Pinion	Handle Repair	Blade Clutch
20054	CD	SB	RK	PP2	None
20055	CD	SB	RK	PP2	None
20056	CD	SB	RK	PP2	BOS
20057	CD	SB	RK	PP2	None
20058	CD	SB	RK	PP2	BOS
20070	22stl	B	SR	PP2	None
20079	22stl	B	SR	PP2	None
20106	CD	3SP	RK	1B	BBC
20107	CD	3SP	RK	1B	BBC
20192	CD	NS	None	PP2	None
20194	CD	NS	None	PP2	BBC
20197	CD	NS	None	PP2	BBC
20897	CD	NS	None	PP2	BBC
20210	CD	3SP	RK	1B	BBC
20211	CD	3SP	RK	1B	BBC
20214	CD	3SP	RK	1B	None
20216	CD	3SP	RK	1B	None
20218	CD	3SP	RK	1B	None
20219	CD	3SP	RK	1B	BBC
20314	20stl	NS	None	2B	None
20316	20stl	NS	None	2B	None
20320	CD	3SP	RK	1B	None
20321	CD	3SP	RK	1B	None
20322	CD	3SP	RK	1B	None
20324	CD	3SP	RK	1B	BBC
20325	CD	3SP	RK	1B	BBC
20327B	CD	3SP	RK	1B	None

# USING THIS MANUAL

## Code List

1B – one bail	ADS – Automatic Drive System
2B – two bail	ES1 – Easy Stride 1st generation
3S – 3-speed	ES2 – Easy Stride 2nd generation
20stl – 20” steel deck	PP1 – Personal Pace 1st generation
21stl – 21” steel deck	PP2 – Personal Pace 2nd generation
22stl – 22” steel deck	B – bevel gear
BBC – blade brake clutch	RK – rocking key
BBC VP – blade brake clutch for Vacu-Power	SB – spur bevel
BOS – blade override system	SR – spring ratchet
CD – cast deck	SS – Sens-a-Speed
CDVP – cast deck Vacu-Power	W – worm
INS – Insight	NS – not serviceable

Model	Trans R&R	Trans Internal Repair	Wheel Pinion	Handle Repair	Blade Clutch
20328B	CD	3SP	RK	1B	None
20330	22stl	NS	None	2B	None
20330C	22stl	NS	None	2B	None
20331	22stl	NS	None	2B	None
20331C	22stl	NS	None	2B	None
20332	22stl	NS	None	PP2	None
20332C	22stl	NS	None	PP2	None
20333	22stl	NS	None	PP2	BBC
20333C	22stl	NS	None	PP2	BBC
20334	22stl	NS	None	PP2	None
20334C	22stl	NS	None	PP2	None
20338	22stl	NS	None	2B	None
20350	22stl	NS	None	2B	None
20351	22stl	NS	None	2B	None
20352	22stl	NS	None	PP2	None
20370	22stl	NS	None	2B	None
20371	22stl	NS	None	2B	None
20372	22stl	NS	None	PP2	None
20373	22stl	NS	None	PP2	BBC
20374	22stl	NS	None	PP2	None
20376	22stl	NS	None	PP2	BBC
20377	22stl	NS	None	2B	None
20378	22stl	NS	None	2B	None
20380	CD	NS	None	2B	None
20381	CD	NS	None	PP2	None
20382	CD	NS	None	PP2	None
20383	CD	NS	None	PP2	BBC



# USING THIS MANUAL

## Code List

1B – one bail	ADS – Automatic Drive System
2B – two bail	ES1 – Easy Stride 1st generation
3S – 3-speed	ES2 – Easy Stride 2nd generation
20stl – 20" steel deck	PP1 – Personal Pace 1st generation
21stl – 21" steel deck	PP2 – Personal Pace 2nd generation
22stl – 22" steel deck	B – bevel gear
BBC – blade brake clutch	RK – rocking key
BBC VP – blade brake clutch for Vacu-Power	SB – spur bevel
BOS – blade override system	SR – spring ratchet
CD – cast deck	SS – Sens-a-Speed
CDVP – cast deck Vacu-Power	W – worm
INS – Insight	NS – not serviceable

Model	Trans R&R	Trans Internal Repair	Wheel Pinion	Handle Repair	Blade Clutch
20384	CD	NS	None	PP2	None
20388	CD	NS	None	PP2	None
20436	CD	3SP	RK	1B	None
20436WF	CD	3SP	RK	1B	None
20437	CD	3SP	RK	1B	None
20438	CD	3SP	RK	1B	BBC
20438WF	CD	3SP	RK	1B	BBC
20439	CD	3SP	RK	1B	BBC
20439WF	CD	3SP	RK	1B	BBC
20442	CD	SB	RK	1B	None
20444	CD	SB	RK	1B	None
20462	CD	3SP	RK	1B	None
20463	CD	3SP	RK	1B	None
20464	CD	3SP	RK	1B	None
20465	CD	3SP	RK	1B	BBC
20466	CD	3SP	RK	1B	BBC
20470	CD	3SP	RK	1B	None
20472	CD	3SP	RK	1B	None
20473	CD	3SP	RK	1B	None
20474	CD	3SP	RK	1B	None
20475	CD	3SP	RK	1B	BBC
20476	CD	3SP	RK	1B	BBC
20478	CD	3SP	RK	1B	None
20479	CD	3SP	RK	1B	None
20480	CD	3SP	RK	1B	None
20481	CD	3SP	RK	1B	None
20482	CD	3SP	RK	1B	BBC

# USING THIS MANUAL

## Code List

1B – one bail	ADS – Automatic Drive System
2B – two bail	ES1 – Easy Stride 1st generation
3S – 3-speed	ES2 – Easy Stride 2nd generation
20stl – 20” steel deck	PP1 – Personal Pace 1st generation
21stl – 21” steel deck	PP2 – Personal Pace 2nd generation
22stl – 22” steel deck	B – bevel gear
BBC – blade brake clutch	RK – rocking key
BBC VP – blade brake clutch for Vacu-Power	SB – spur bevel
BOS – blade override system	SR – spring ratchet
CD – cast deck	SS – Sens-a-Speed
CDVP – cast deck Vacu-Power	W – worm
INS – Insight	NS – not serviceable

Model	Trans R&R	Trans Internal Repair	Wheel Pinion	Handle Repair	Blade Clutch
20483	CD	3SP	RK	1B	BBC
20486	CD	3SP	RK	1B	None
20487	CD	3SP	RK	1B	BBC
20488	CD	3SP	RK	1B	None
20489	CD	3SP	RK	1B	None
20490	CD	3SP	RK	1B	BBC
20494	CD	3SP	RK	1B	None
20495	CD	3SP	RK	1B	None
20622	CD	3SP	RK	1B	BBC
20632	CD	3SP	RK	1B	BBC
20652	21stl	SB	RK	PP1	None
20654	21stl	SB	RK	PP2	None
20655	22stl	B	SR	PP2	None
20656	22stl	B	SR	PP2	None
20666	CD	3SP	RK	1B	None
20667	CD	3SP	RK	1B	BBC
20668	CD	3SP	RK	1B	None
20677	CD	3SP	RK	1B	None
20680	CD	3SP	RK	1B	None
20692	CD	3SP	RK	1B	None
20695	CD	3SP	RK	1B	BBC
20711	CD	SB	RK	1B	None
20761B	CD	3SP	RK	1B	None
20763B	CD	3SP	RK	1B	None
20764B	CD	3SP	RK	1B	None
20764BC	CD	3SP	RK	1B	None
20766B	CD	3SP	RK	1B	None

# USING THIS MANUAL

## Code List

1B – one bail	ADS – Automatic Drive System
2B – two bail	ES1 – Easy Stride 1st generation
3S – 3-speed	ES2 – Easy Stride 2nd generation
20stl – 20” steel deck	PP1 – Personal Pace 1st generation
21stl – 21” steel deck	PP2 – Personal Pace 2nd generation
22stl – 22” steel deck	B – bevel gear
BBC – blade brake clutch	RK – rocking key
BBC VP – blade brake clutch for Vacu-Power	SB – spur bevel
BOS – blade override system	SR – spring ratchet
CD – cast deck	SS – Sens-a-Speed
CDVP – cast deck Vacu-Power	W – worm
INS – Insight	NS – not serviceable

Model	Trans R&R	Trans Internal Repair	Wheel Pinion	Handle Repair	Blade Clutch
20766BC	CD	3SP	RK	1B	None
20767B	CD	3SP	RK	1B	None
20768B	CD	3SP	RK	1B	None
20776	CD	3SP	RK	1B	None
20777	CD	3SP	RK	1B	None
20778	CD	3SP	RK	1B	None
20781	CD	SB	RK	PP2	None
20783	CD	SB	RK	PP2	None
20784	CD	SB	RK	PP2	None
20786	CD	3SP	RK	1B	None
20787	CD	3SP	RK	1B	None
20792	CD	SB	RK	PP2	None
20793	CD	SB	RK	PP2	None
20795	CD	SB	RK	PP2	None
20796	CD	SB	RK	PP2	None
20797	CD	NS	None	PP2	None
20817	CD	SB	RK	PP2	None
20819	CD	SB	RK	PP2	None
20828	CD	SB	RK	PP2	None
20831	CD	SB	RK	PP2	None
20832	CD	SB	RK	PP2	None
20833	CD	SB	RK	PP2	None
20835	CD	NS	None	PP2	None
20836	CD	NS	None	PP2	None
20837	CD	NS	None	PP2	None
20905	CD	Worm	RK	1B	None
20905B	CD	Worm	RK	1B	None

# USING THIS MANUAL

## Code List

1B – one bail	ADS – Automatic Drive System
2B – two bail	ES1 – Easy Stride 1st generation
3S – 3-speed	ES2 – Easy Stride 2nd generation
20stl – 20” steel deck	PP1 – Personal Pace 1st generation
21stl – 21” steel deck	PP2 – Personal Pace 2nd generation
22stl – 22” steel deck	B – bevel gear
BBC – blade brake clutch	RK – rocking key
BBC VP – blade brake clutch for Vacu-Power	SB – spur bevel
BOS – blade override system	SR – spring ratchet
CD – cast deck	SS – Sens-a-Speed
CDVP – cast deck Vacu-Power	W – worm
INS – Insight	NS – not serviceable

Model	Trans R&R	Trans Internal Repair	Wheel Pinion	Handle Repair	Blade Clutch
20906B	CD	Worm	RK	1B	None
20911B	CD	Worm	RK	1B	None
20915	CD	Worm	RK	1B	None
20916B	CD	Worm	RK	1B	None
20920	CD	Worm	RK	1B	None
20920B	CD	Worm	RK	1B	None
20921B	CD	Worm	RK	1B	None
20925	CD	Worm	RK	1B	None
20925B	CD	Worm	RK	1B	None
20926B	CD	Worm	RK	1B	None
20927B	CD	Worm	RK	1B	None
20995	21stl	NS	None	2B	None
20996	21stl	NS	None	SS	None
20997	21stl	NS	None	SS	None
20999	21stl	NS	None	ADS	None
20192	CD	NS	None	ADS	None
20194	CD	NS	None	ADS	BBC
20197	CD	NS	None	ADS	BBC
20897	CD	NS	None	ADS	BBC
20899	CD	NS	None	ADS	None
22156	CD	NS	None	2B	None
22156TE	CD	NS	None	2B	None
22186TE	CD	NS	None	2B	None
22271	21stl	NS	None	2B	None
26620B	CD VP	3SP	RK	1B	None
26620BF	CD VP	3SP	RK	1B	None
26620BG	CD VP	3SP	RK	1B	None

# USING THIS MANUAL

## Code List

1B – one bail	ADS – Automatic Drive System
2B – two bail	ES1 – Easy Stride 1st generation
3S – 3-speed	ES2 – Easy Stride 2nd generation
20stl – 20” steel deck	PP1 – Personal Pace 1st generation
21stl – 21” steel deck	PP2 – Personal Pace 2nd generation
22stl – 22” steel deck	B – bevel gear
BBC – blade brake clutch	RK – rocking key
BBC VP – blade brake clutch for Vacu-Power	SB – spur bevel
BOS – blade override system	SR – spring ratchet
CD – cast deck	SS – Sens-a-Speed
CDVP – cast deck Vacu-Power	W – worm
INS – Insight	NS – not serviceable

Model	Trans R&R	Trans Internal Repair	Wheel Pinion	Handle Repair	Blade Clutch
26621	CD VP	3SP	RK	1B	BBC VP
26621B	CD VP	3SP	RK	1B	BBC VP
26622	CD VP	3SP	RK	1B	BBC VP
26623	CD VP	3SP	RK	1B	BBC VP
26624	CD VP	3SP	RK	1B	BBC VP
26625B	CD VP	3SP	RK	1B	None
26625BG	CD VP	3SP	RK	1B	None
26626	CD VP	3SP	RK	1B	BBC VP
26630B	CD VP	3SP	RK	1B	None
26630BC	CD VP	3SP	RK	1B	None
26630BG	CD VP	3SP	RK	1B	None
26631B	CD VP	3SP	RK	1B	BBC VP
26631BC	CD VP	3SP	RK	1B	BBC VP
26632	CD VP	3SP	RK	1B	None
26632B	CD VP	3SP	RK	1B	None
26633	CD VP	3SP	RK	1B	BBC VP
26633B	CD VP	3SP	RK	1B	BBC VP
26635B	CD VP	3SP	RK	1B	None
26635BC	CD VP	3SP	RK	1B	None
26635BG	CD VP	3SP	RK	1B	None
26636	CD VP	3SP	RK	1B	None
26636B	CD VP	3SP	RK	1B	None
26637	CD VP	3SP	RK	1B	None
26638	CD VP	3SP	RK	1B	BBC VP
26639	CD VP	3SP	RK	1B	None
26640B	CD VP	3SP	RK	1B	None
26640BC	CD VP	3SP	RK	1B	None

# USING THIS MANUAL

---

## Code List

---

1B – one bail	ADS – Automatic Drive System
2B – two bail	ES1 – Easy Stride 1st generation
3S – 3-speed	ES2 – Easy Stride 2nd generation
20stl – 20” steel deck	PP1 – Personal Pace 1st generation
21stl – 21” steel deck	PP2 – Personal Pace 2nd generation
22stl – 22” steel deck	B – bevel gear
BBC – blade brake clutch	RK – rocking key
BBC VP – blade brake clutch for Vacu-Power	SB – spur bevel
BOS – blade override system	SR – spring ratchet
CD – cast deck	SS – Sens-a-Speed
CDVP – cast deck Vacu-Power	W – worm
INS – Insight	NS – not serviceable

Model	Trans R&R	Trans Internal Repair	Wheel Pinion	Handle Repair	Blade Clutch
26643	CD VP	3SP	RK	1B	None
26643B	CD VP	3SP	RK	1B	None
26680	CD VP	3SP	RK	1B	None
26680WG	CD VP	3SP	RK	1B	None
26682	CD VP	3SP	RK	1B	BBC VP
26683	CD VP	3SP	RK	1B	BBC VP
27500	CD VP	3SP	RK	1B	BBC VP
27501	CD VP	3SP	RK	1B	BBC VP
27502	CD VP	3SP	RK	1B	BBC VP
29639	20stl	NS	None	2B	None
29643	20stl	NS	None	2B	None

# SAFETY INFORMATION

<b>Safety Information . . . . .</b>	<b>1</b>
Worm Drive Transmission . . . . .	2
Single Speed Spur/Bevel Gear Transmission . . . . .	3
Single Speed Bevel Gear Transmission . . . . .	4
Three Speed Transmission . . . . .	5
General Transmissions® . . . . .	6
Wheel Pinion Clutch . . . . .	7
Blade Brake Clutch Systems (BBC), Blade Override System (BOS), Blade Clutch Systems (BCS) . . . . .	8
Handles and Control Cables . . . . .	9
Self-Propel Belt Replacement . . . . .	10

# SAFETY INFORMATION

---

## General Information



This symbol means WARNING or PERSONAL SAFETY INSTRUCTION – read the instruction because it has to do with your safety. Failure to comply with the instruction may result in personal injury or even death.

This manual is intended as a service and repair manual only. The safety instructions provided herein are for service, and repair of Toro and Lawn-Boy walk behind mowers.

## Think Safety First

### Avoid unexpected starting of engine...

Always turn off the engine and disconnect the spark plug wire(s) before cleaning, adjusting, or repair.

### Avoid lacerations and amputations...

Stay clear of all moving parts whenever the engine is running. Treat all normally moving parts as if they were moving whenever the engine is running or has the potential to start.

### Avoid burns...

Do not touch the engine, muffler, or other components, which may increase in temperature during operation, while the unit is running or shortly after it has been running.

### Avoid fires and explosions...

Avoid spilling fuel and never smoke while working with any type of fuel or lubricant. Wipe up any spilled fuel or oil immediately. Never remove the fuel cap or add fuel when the engine is running. Always use approved, labeled containers for storing or transporting fuel and lubricants.

### Avoid asphyxiation...

Never operate an engine in a confined area without proper ventilation.

The operator's manuals contain safety information and operating tips for safe operating practices. Operator's manuals are available online through your Toro parts source or:

**The Toro Company**  
**Publications Department**  
**8111 Lyndale Avenue South**  
**Bloomington, MN 55420**

### Avoid injury from batteries...

Battery acid is poisonous and can cause burns. Avoid contact with skin, eyes and clothing. Battery gases can explode. Keep cigarettes, sparks and flames away from the battery.

### Avoid injury due to inferior parts...

Use only original equipment parts to ensure that important safety criteria are met.

### Avoid injury to bystanders...

Always clear the area of bystanders before starting or testing powered equipment.

### Avoid injury due to projectiles...

Always clear the area of sticks, rocks or any other debris that could be picked up and thrown by the powered equipment.

### Avoid modifications...

Never alter or modify any part unless it is a factory approved procedure.

### Avoid unsafe operation...

Always test the safety interlock system after making adjustments or repairs on the machine. Refer to the Electrical section in this manual for more information.



# WORM DRIVE TRANSMISSION

---

Safety Information . . . . .	1
<b>Worm Drive Transmission . . . . .</b>	<b>2</b>
Single Speed Spur/Bevel Gear Transmission . . . . .	3
Single Speed Bevel Gear Transmission . . . . .	4
Three Speed Transmission . . . . .	5
General Transmissions® . . . . .	6
Wheel Pinion Clutch . . . . .	7
Blade Brake Clutch Systems (BBC), Blade Override System (BOS), Blade Clutch Systems (BCS) . . . . .	8
Handles and Control Cables . . . . .	9
Self-Propel Belt Replacement . . . . .	10

# WORM DRIVE TRANSMISSION

## GENERAL

There are two versions of the worm drive transmission. The first is a clutch type and is used on 21" front wheel drive mowers. The second version is constant mesh and is used on International 48cm rear wheel drive mowers.

## INTERNALLY CLUTCHED

### Description

This is a worm and helical gear transmission. The worm shaft (input shaft) is driven by a belt from the engine crankshaft. A spring which hooks into the tab on the front of the transmission (where the roll pin is) and to

the mower housing, pivots the transmission forward to maintain tension on the belt.

The worm is in constant mesh with the helical gear. The clutching action is provided by a sliding clutch jaw. A shift fork moves the clutch jaw to engage and disengage the transmission. When the clutch jaw engages the helical gear, power is transferred from the clutch jaw to the sleeve inside the clutch jaw. The sleeve is pinned to the axle. The axle then begins to rotate (Fig. 001).

- |                 |                                |
|-----------------|--------------------------------|
| A. Belt         | E. Shift Fork                  |
| B. Spring       | F. Sleeve                      |
| C. Helical Gear | G. Input Shaft<br>(worm shaft) |
| D. Clutch Jaw   |                                |

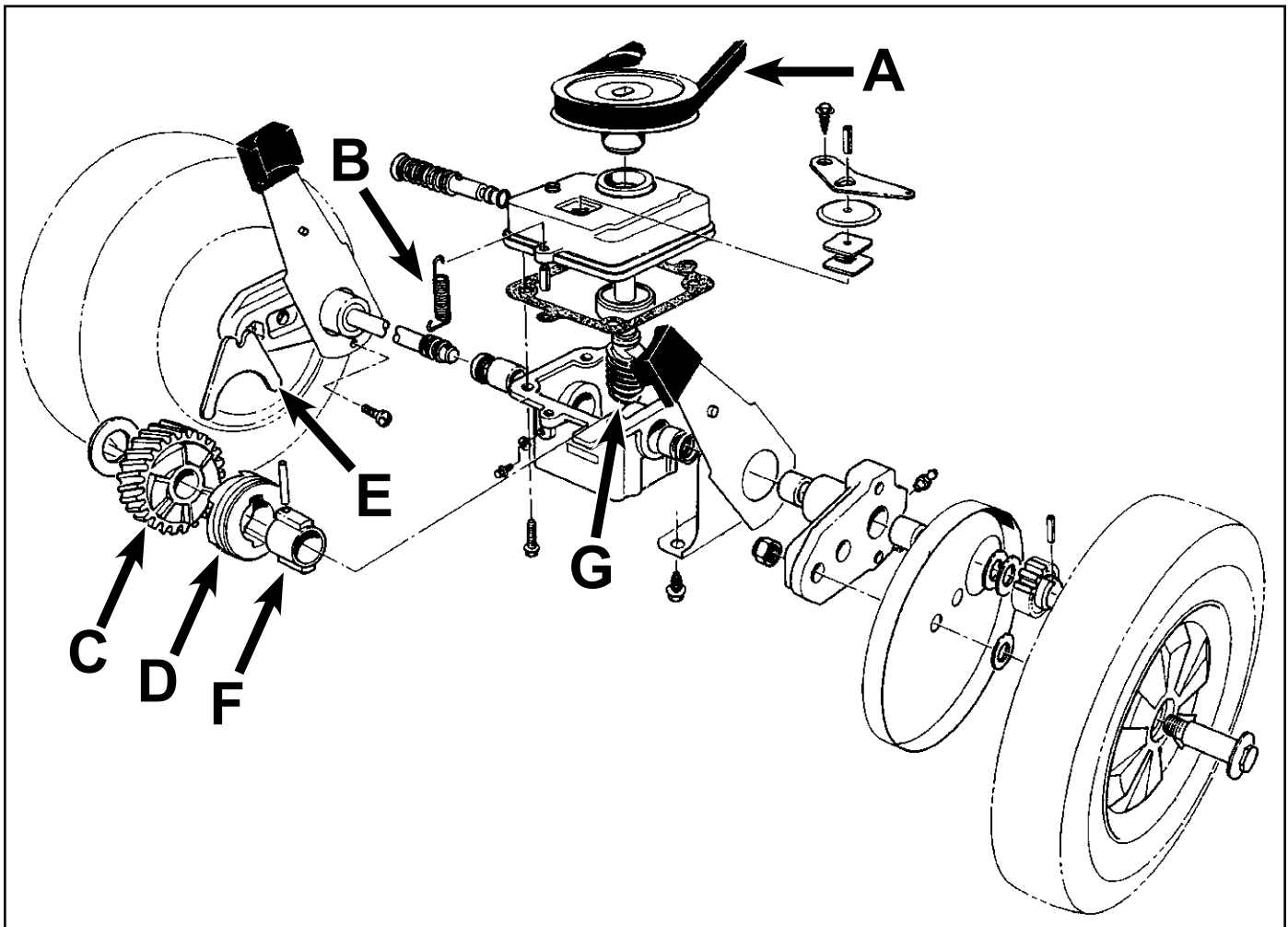

Fig. 001

fig. 1

# WORM DRIVE TRANSMISSION

## Lubrication

This transmission requires 90 wt. gear oil. A variable weight such as 85w90 is acceptable as long as the range includes 90 weight. The second part of the requirement is an EP rating of GL 5 or higher.

The transmission has a fill/check plug in the front. With the transmission level, fill until level with the hole. **NOTE:** This is equal to about the center of the axle.

Unless the case is cracked, oil can not leak out. Even if a seal fails, oil will leak out only to the bottom of the seal on the axle.

If gear failure occurs, the resulting friction can cook the oil down to a smear in the bottom of the case. This does not indicate a lack of lubrication.

This type of transmission will last less than 30 minutes with no lubrication. If a transmission lasts even a few weeks in consumer use, it had lubrication to start.

## The Shifting Process

The upper end of the clutch fork slides over a groove in a spring loaded rod. This spring pushes the shift fork and clutch jaw towards the engaged position (Fig. 002).

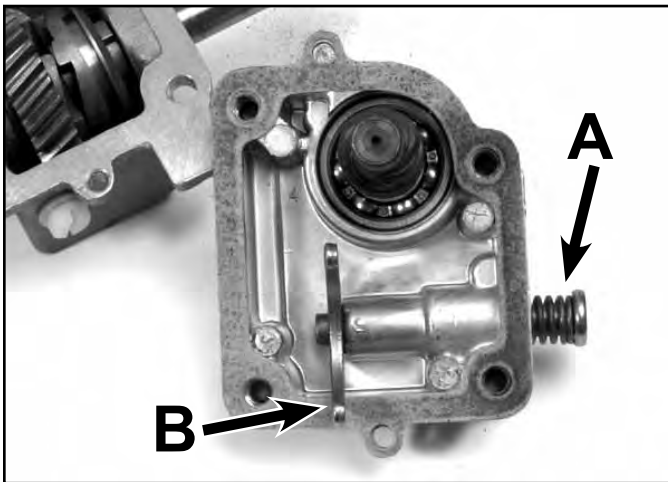

Fig 002

3428-0150

A. Shift Rod

B. Shift Fork

The shift rod has a roll pin protruding through the top of the transmission. This pin goes through a latch plate with an L shaped slot in it. The slot guides the pin in its travel from engagement to disengagement. Above the latch plate is a dust filter and a dust cover. The shift arm on top of the transmission holds all these parts in place (Fig. 003).

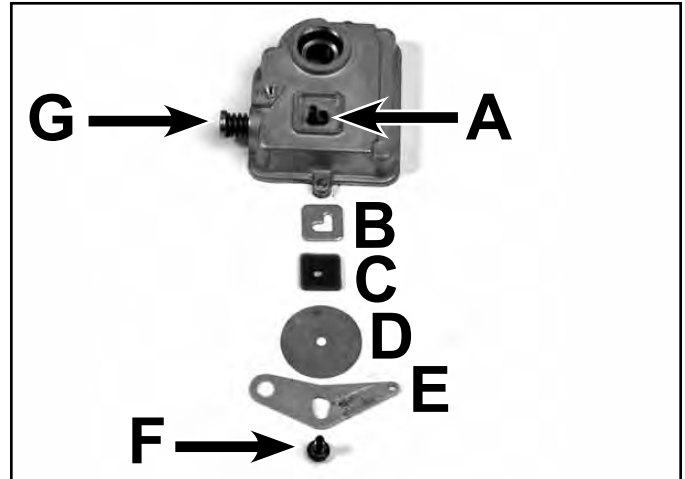

Fig 003

3428-0165

A. Roll Pin

E. Shift Arm

B. Latch Plate

F. Screw

C. Dust Filter

G. Shift Rod

D. Dust Cover

When the shift arm is pulled to the rear by the shift cable, the pin moves to the left side of the mower, then to the rear. This moves the shift pin, the shift fork, and the clutch jaw to the disengage position.

**Note: Dirt packed in the latch plate can prevent disengagement. The dust filter and dust cover help prevent this failure.**

When the shift cable is engaged, tension on the shift arm is released. The spring on the shift rod applies pressure to the rod, fork, and clutch jaw to engage the transmission.

# WORM DRIVE TRANSMISSION

## Removal & Installation (front wheel drive applications)

1. Remove the belt cover and unhook the spring on the front of the transmission. Slip the belt off the transmission pulley (Fig. 004).

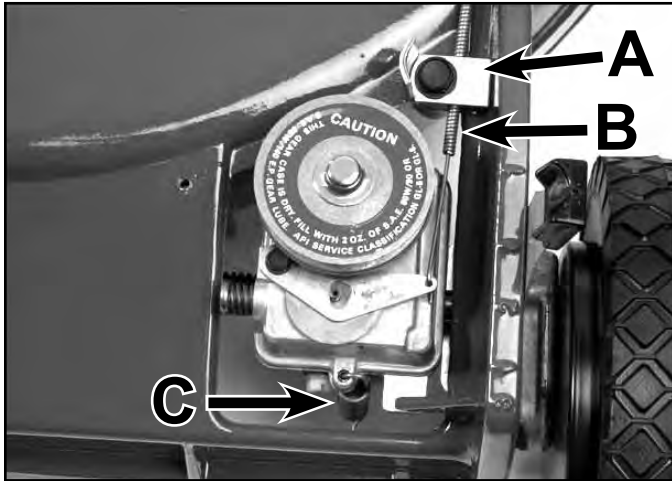

Fig 004

3428-0127

- A. Cable Clamp                      C. Spring  
B. Shift Cable

2. Raise the front of the mower off the bench and support it with blocks.
3. Disconnect the shift cable.

4. Remove both front wheels and wheel covers (Fig. 005).

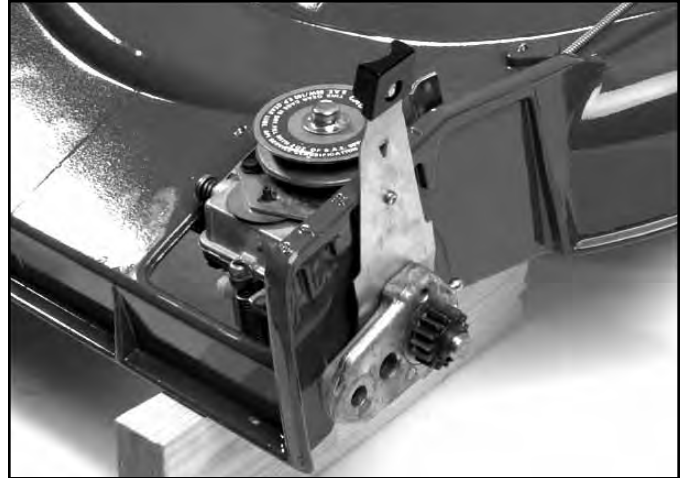

Fig 005

3428-0129

5. Pivot (both) front spring arms forward until they point straight down. (This removes the tension from the pivot arms so the roll pin can be removed) (Fig. 006).

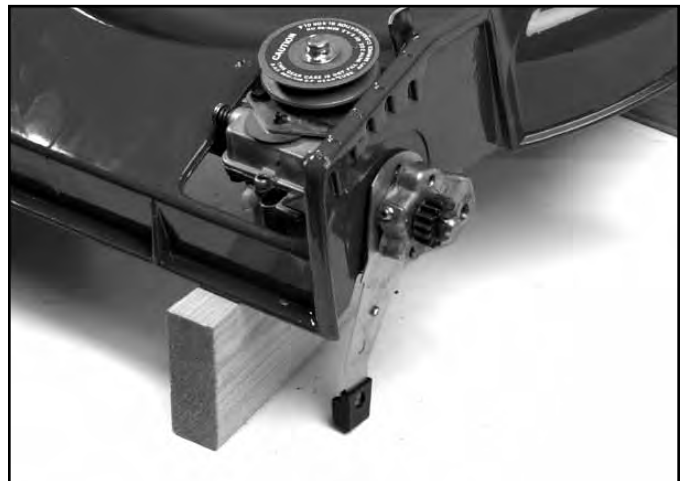

Fig 006

3428-0131

# WORM DRIVE TRANSMISSION

- Place a block of wood under the wheel pinion for support and drive the roll pin out of the axle (Fig. 007). Repeat the process on the other side.

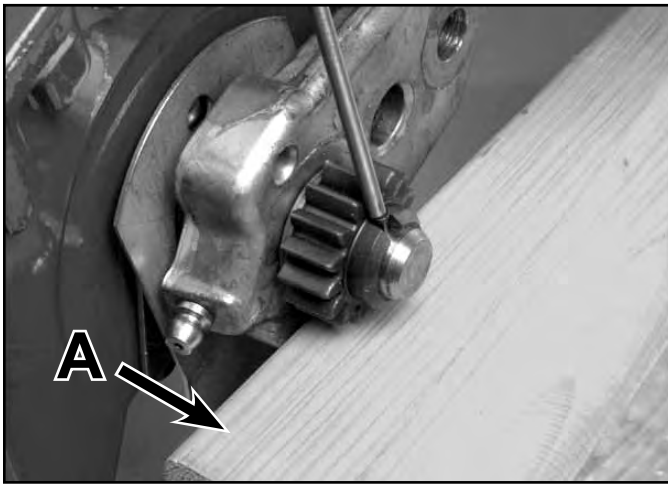

Fig 007

3428-0135

- A. Wood Block

- The wheel pinion, thrust washer, pivot, and spring arm will now slide off the end of the axle (Fig. 008). Repeat the process on the other side.



Fig 008

3428-0137

- Remove the transmission from the chassis.
- Reverse the procedure to install.

**Note:** Support the wheel pinions with the wood block while driving the roll pins in. This will prevent the axle from being bent. Fill the transmission with oil after it is installed in the mower (Fig. 009).

Note the front of the transmission is identified by the oil fill/check screw and the flat tab which is part of the lower case.

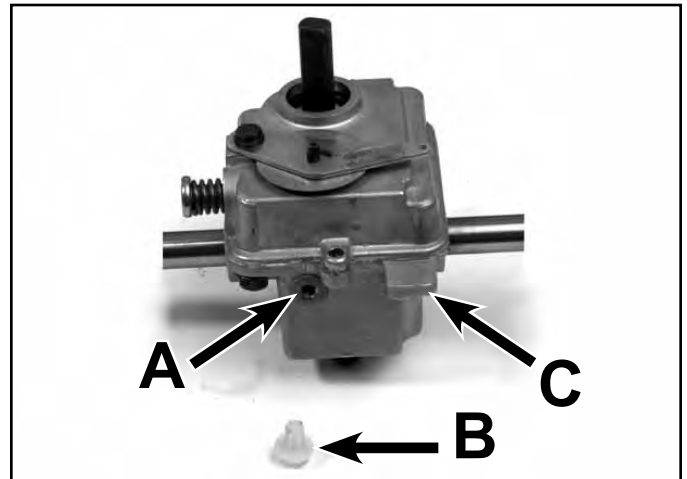

Fig 009

3428-0166

- A. Fill/Check  
B. Plug  
C. Tab

## Disassembly

- Cut and discard the push-on retainer on top of the transmission pulley. Remove the belt and pulley.

# WORM DRIVE TRANSMISSION

2. Drive the roll pins out of the flanges in the front and rear of the case. (These pins align the top and bottom parts of the case) (Fig. 010).

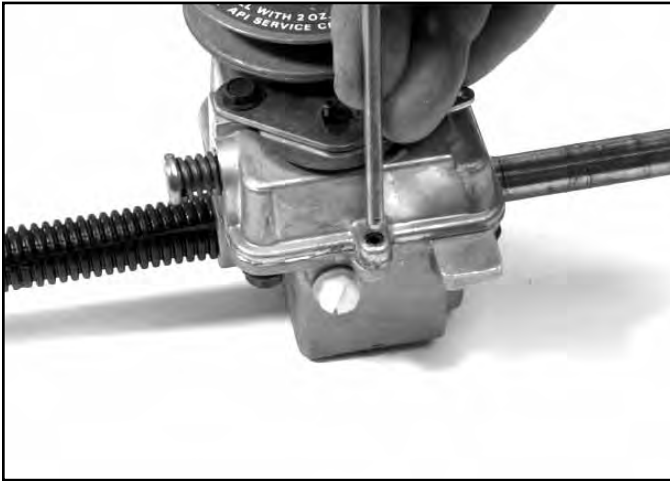

Fig 010 3428-0146

5. Push the worm shaft out of the cover. This may require a little pressure.
6. To remove the axle, slide the clutch jaw to the side and drive the roll pin out of the sleeve and axle (Fig. 012).



Fig 012 3428-0151

3. Remove the 4 self-tapping screw that connect the top and bottom cases.

**Note: If you turn this transmission on its side or upside down, oil may leak out of the top. This is not a sealed case.**

4. Remove the transmission cover. The shift fork may come with the cover or may fall into the bottom of the case (Fig. 011).

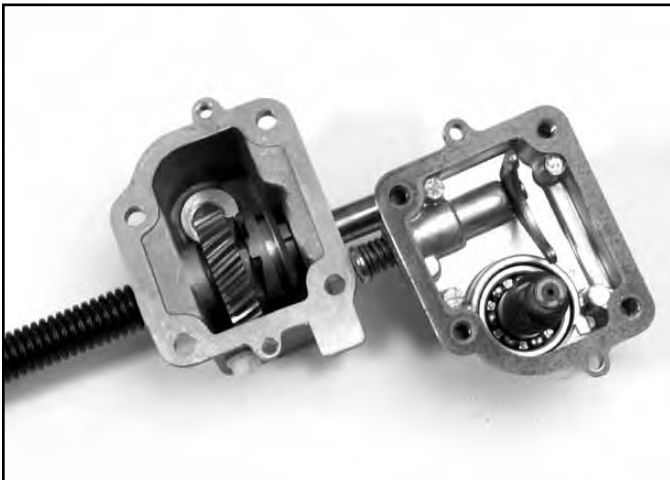

Fig 011 3428-0148

7. If the axle bearings are to be re-used, clean the end of the axle before drawing it out of the case.
8. Remove the sleeve, clutch jaw, helical gear, and thrust washer (Fig. 013)

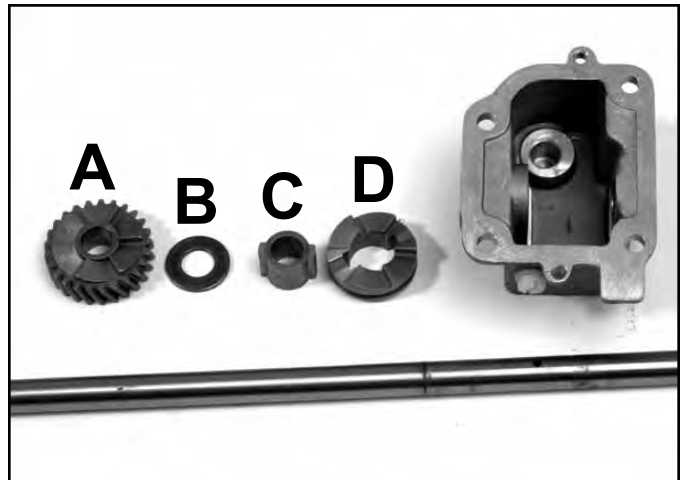

Fig 013 3428-0153

- |                  |               |
|------------------|---------------|
| A. Helical Gear  | C. Sleeve     |
| B. Thrust Washer | D. Clutch Jaw |

# WORM DRIVE TRANSMISSION

9. Clean the old gasket material from the mating surfaces of the case and cover.
10. A hook or small screwdriver can be used to pry the seals out of the case.
11. An arbor press or large vise will be needed when removing and replacing the bushings.
12. Clean the oil residue and any metal shavings from the case.
13. Worm and helical gears are sold as a set. Even after a short run time, they will develop a wear pattern. Replacing only one gear will result in rapid failure (Fig. 014).

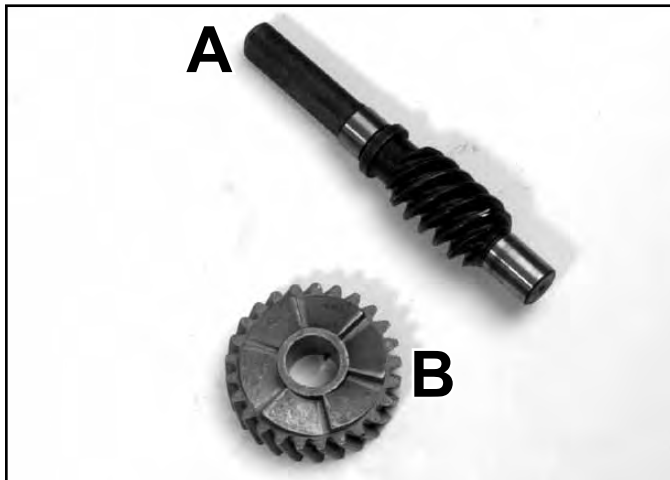

Fig 014 3428-0157

- A. Worm Shaft                      B. Helical Gear

14. Remove the screw from the shift arm and remove the shift arm, dust cover, and wear plate (Fig. 015). If the ball bearing is to be replaced, press it out at this time.

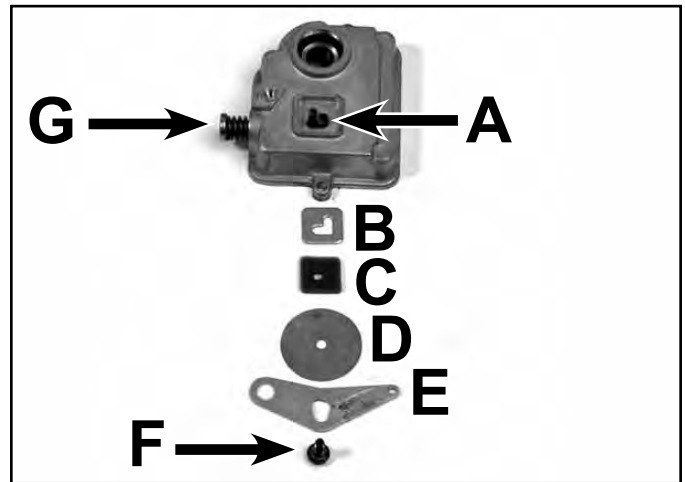

Fig 015 3428-0165

- |                |              |
|----------------|--------------|
| A. Roll Pin    | E. Shift Arm |
| B. Latch Plate | F. Screw     |
| C. Dust Filter | G. Shift Rod |
| D. Dust Cover  |              |

15. Remove the roll pin and pull shifter rod out of the cover. Clean the cover.

# WORM DRIVE TRANSMISSION

## Assembly

1. Use bushing installation tool P/N 27-0460, to press in new axle bushings. This tool helps keep the bushing straight and keeps the inner diameter of the bushing correctly sized.

**Note:** The bushings are two different lengths. The side of the case with the thicker boss uses a longer bushing to support the axle. The bushings should be flush with the inside of the case (Fig. 016).

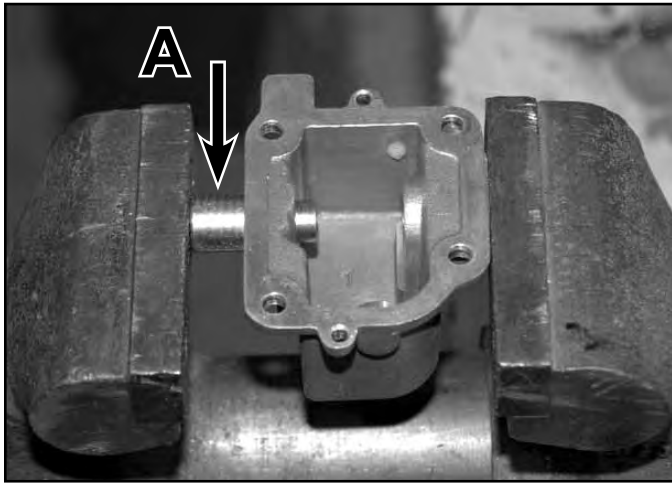

Fig 016 3428-0158

- A. Tool P/N 27-0460

2. Clean the rust and dirt from the both ends of the axle. Wipe the inner diameter of the bushings with a clean cloth. Lightly oil the axle and insert it into the gear case. When facing the front of the gearbox, insert the short end of the axle from left to right. Install the thrust washer, helical gear, and the sleeve and clutch jaw. Then push the axle through the other side of the case.

3. Note: Some replacement axles have more than one hole that can be used to pin the sleeve to the axle. Refer to the original axle to identify the correct hole to use. Then drive a roll pin through the sleeve and axle (Fig. 017).



Fig 017 3428-0151

4. Using a seal protector, slide new seals down each side of the axle, Install the seal with the lip facing the transmission. The outer edge of the seal should be flush with the outside of the case. If a seal protector is not available, wrap a piece of cellophane around the axle (Fig. 018).

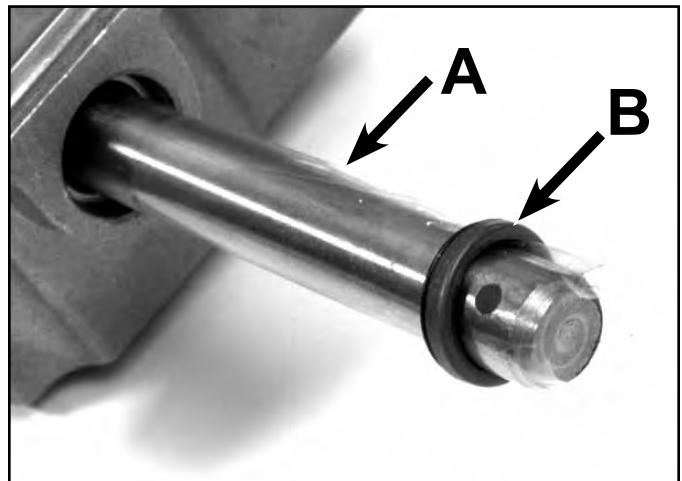

Fig 018 3428-0170

- A. Seal protector or Cellophane      B. Seal



# WORM DRIVE TRANSMISSION

5. If the bearing in the cover is being replaced, use tool P/N 27-0490 to press it in place. This bearing only has one seal. Install the bearing such that the seal is visible from the top of the cover and the open side faces the gears. Press the bearing in until it is fully seated in the case (Fig. 019).

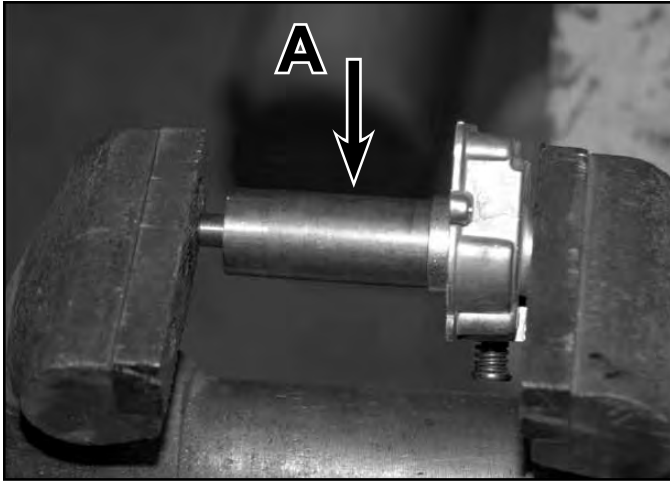

Fig 019

3428-0159

- A. Tool P/N 27-0490

6. Install worm shaft in bearing.
7. Use a new gasket. Install the cover on the bottom case and start the 4 self-tapping screws. Do not fully tighten them.
8. Install the front and rear roll pins to align the cover and case. Then secure the 4 self-tapping screws.

9. Fill the transmission with gear oil AFTER it is installed in the mower. The top of this transmission is not sealed. It will leak if tipped on its side (Fig. 020).

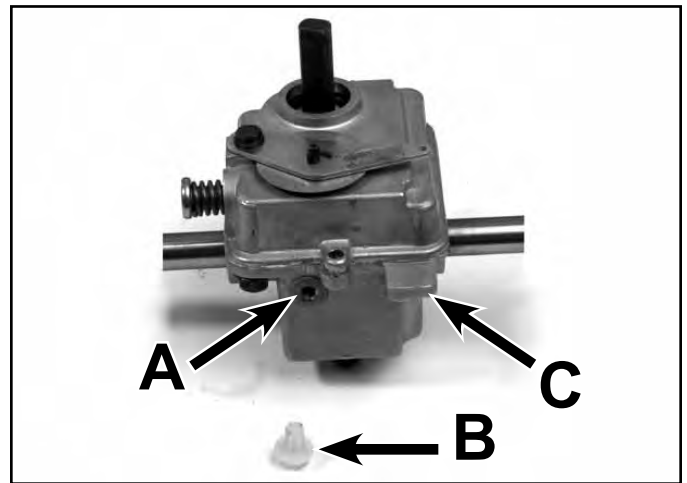

Fig 020

3428-0166

- A. Fill/Check

- B. Plug

# WORM DRIVE TRANSMISSION

---

## Controls

There are two control cables used with this system. One cable operates the engine kill switch and flywheel brake; the other controls the transmission.

## Adjustment

The transmission cable is a standard lever type. Since the spring and pin on top of the transmission pushes the shift fork towards the engaged position, the cable pulls the shift arm to the rear to disengage the transmission. The adjustment point is on the mower housing just to the rear of the transmission. To adjust, pull the control to the rear (disengage). Go to the cable clamp/adjustment. Loosen the clamp, pull the cable to the rear until the shift lever is as far back as it will go. Hold it there and tighten the clamp (Fig. 021).

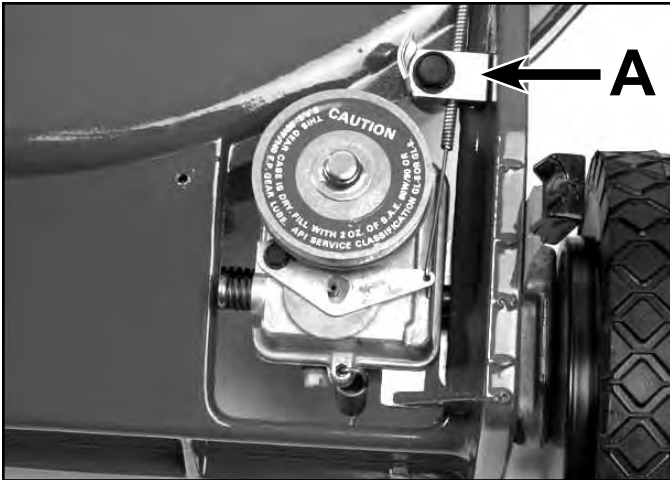

Fig 021

3428-0127

A. Cable Clamp

# WORM DRIVE TRANSMISSION

## CONSTANT MESH

### Description

This transmission is very similar to the "INTERNALLY CLUTCHED" on page 1 – 1. However, the helical gear is different as there is no internal clutching (Fig. 022). Engagement and disengagement is accomplished by pivoting the transmission to tighten or loosen the belt.

Internal repair procedures are the same, as is the lubrication requirement, 90 wt. gear oil rated GL-5 or higher.

- |                       |                          |
|-----------------------|--------------------------|
| 1. Jam nut            | 13. Oil Seal             |
| 2. Lock washer        | 14. Output shaft         |
| 3. Half pulley        | 15. Traction bracket     |
| 4. V Belt             | 16. Thread forming screw |
| 5. Pulley spacer      | 17. Gearbox case         |
| 6. Gearbox cover      | 18. Thrust washer        |
| 7. Shaft & worm       | 19. Roll pin             |
| 8. Ball bearing       | 20. Helical gear         |
| 9. Gearbox gasket     | 21. Thrust washer        |
| 10. Check plug        | 22. Bushing              |
| 11. Gasket check plug | 23. Roll pin             |
| 12. Bushing           |                          |

The constant mesh type transmission is used in a 48cm rear wheel drive application.

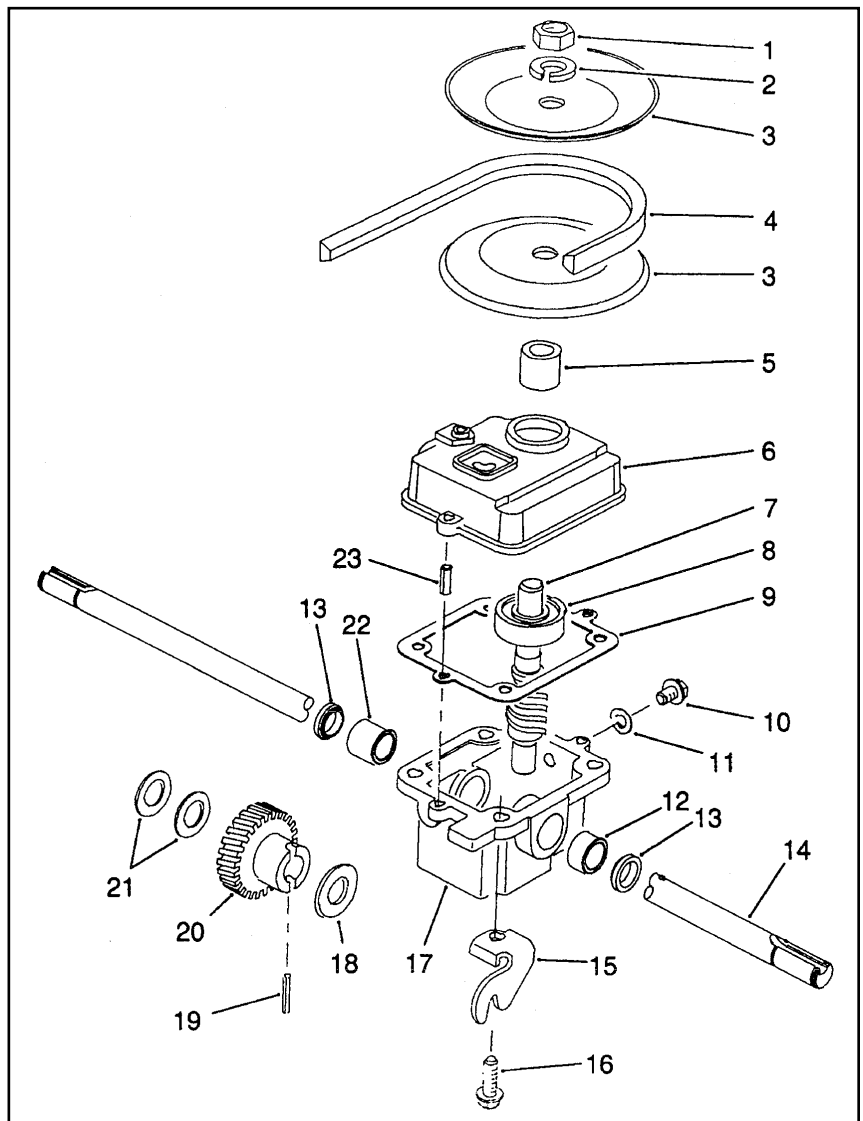

Fig 022

fig 18-A

# WORM DRIVE TRANSMISSION

## Removal and Installation

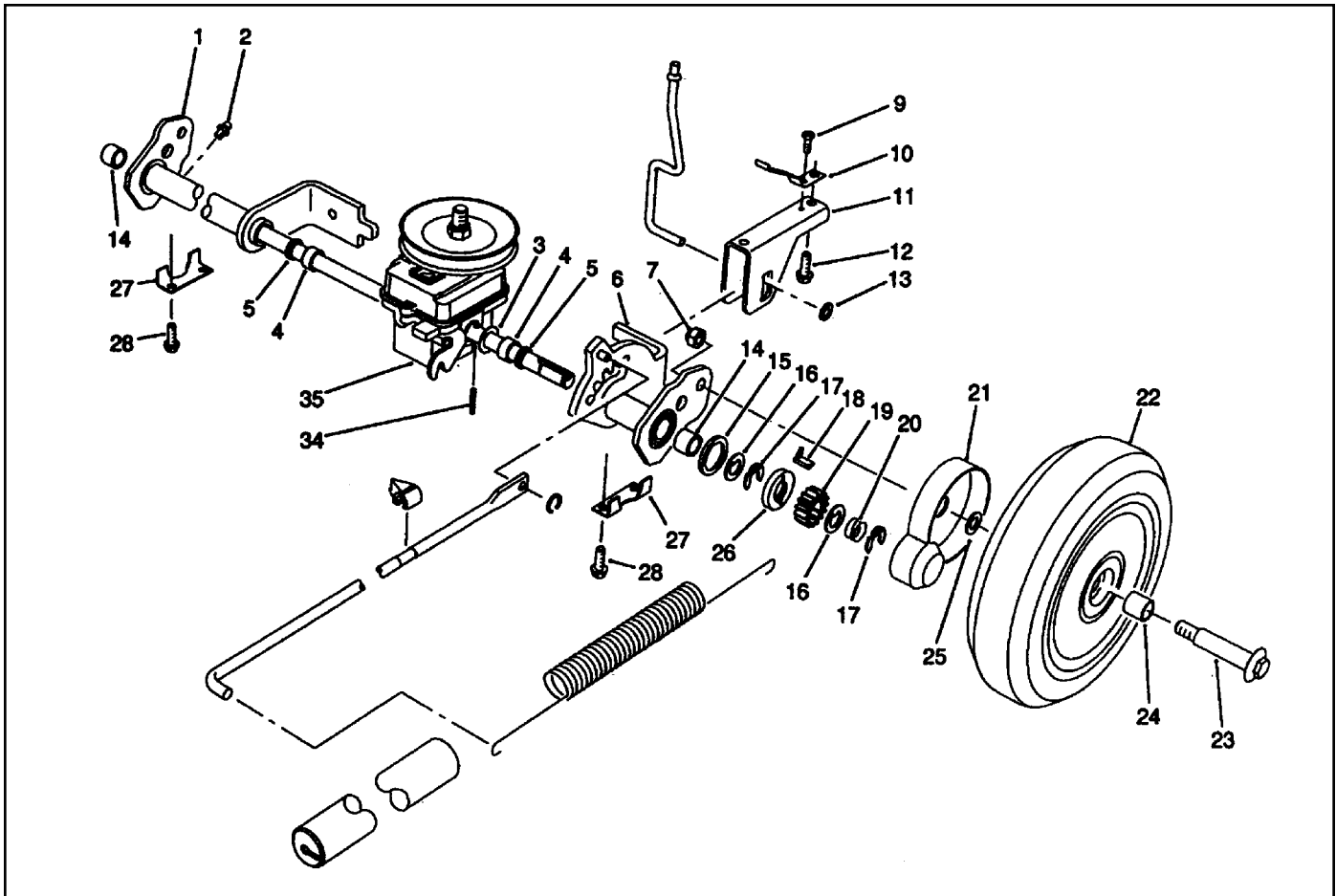

Fig 023 20911B sprearaxleassy

Ref. No.	Qty	Description
1	1	Rear Pivot Assembly RH (incl. Ref. #2, 4, 5 & 14)
2	2	Grease Fitting
3	2	Washer
4	2	Sleeve Bushing
5	2	Grease Seal
6	1	Rear Pivot Assembly LH (incl. Ref. #3, 4, 5 & 14)
7	2	Locknut
9	1	Thread Forming Screw
10	2	Trigger Return Spring
11	1	H.O.C. Saddle
12	2	Thread Forming Screw
13	1	Push Nut
14	2	Needle Bearing
15	2	Friction Washer

Ref. No.	Qty	Description
16	4	Keyed Thrust Washer
17	4	Retaining Ring
18	1	LH Rocking Key
19	2	Pinion Gear
20	2	Compression Spring
21	2	Wheel Cover
22	2	Tire & Gear Assy Wheel (incl. Ref. #24)
23	2	Wheel Bolt
24	4	Wheel Bushing
25	2	Wheel Spacer
26	2	Clutch Washer
27	2	Rear Suspension Plate
28	4	Thread Forming Screw
34	2	Roll Pin
35	1	Gearbox Assembly

# WORM DRIVE TRANSMISSION

To remove the transmission from the mower proceed as follows:

1. Remove both rear wheels.
2. Remove the retaining rings, springs, gears, keys, clutches, and pivot arms on both sides ("Wheel Pinion Clutch" on page 5-2).
3. Remove the belt.
4. There is a suspension bracket on each side that secures the transmission and pivot arms to the chassis. Each bracket has 2 screws. Once they are removed, the transmission will drop out.

To install, reverse the above process.

Fill the transmission level with the fill plug opening after it is installed in the chassis. The top of the transmission is not sealed, so it may leak if filled and tipped.

## Controls

### Adjusting Wheel Traction Drive

1. Stop the engine.
2. Rotate the adjustment knob under the lower left-hand side of the control panel 1/2 turn clockwise to tighten the belt, or 1/2 turn counterclockwise to loosen the belt. Hold the control cable while rotating the knob to prevent the cable from turning (Fig. 024).

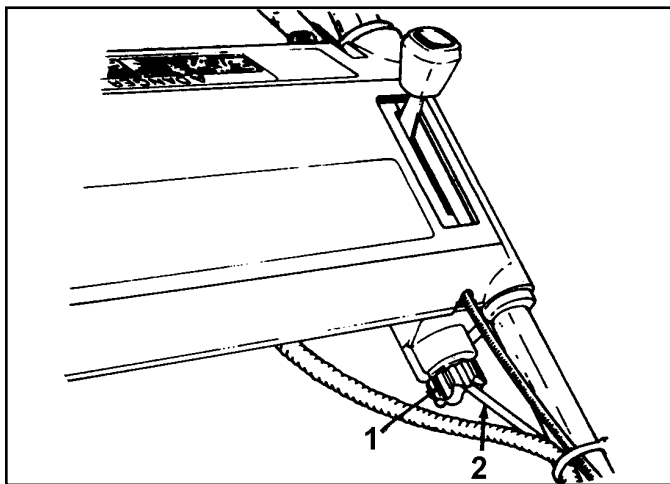

Fig 024

fig 19

1. Knob
2. Cable

3. To check the adjustment, slowly squeeze the control bar towards the handle. The cable is adjusted correctly when resistance is felt when the control bar is approximately 1" (25mm) from the upper handle (Fig. 025).

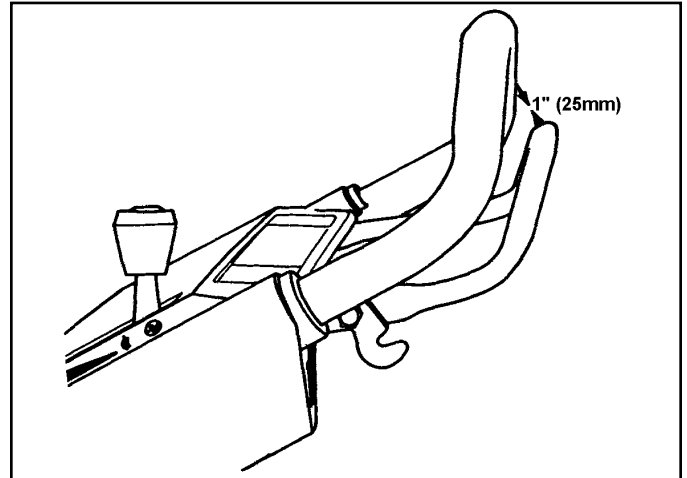

Fig 025

fig 20

4. If loss of traction or improper engagement still occurs after adjustment, repeat steps 2 – 3 until properly adjusted.

## WHEEL CLUTCH

See Rocking Key Wheel Clutch, page 5-3.

**THIS PAGE INTENTIONALLY LEFT BLANK.**

# SINGLE SPEED SPUR/BEVEL GEAR TRANSMISSION

Safety Information . . . . .	1
Worm Drive Transmission . . . . .	2
<b>Single Speed Spur/Bevel Gear Transmission . . . . .</b>	<b>3</b>
Single Speed Bevel Gear Transmission . . . . .	4
Three Speed Transmission . . . . .	5
General Transmissions® . . . . .	6
Wheel Pinion Clutch . . . . .	7
Blade Brake Clutch Systems (BBC), Blade Override System (BOS), Blade Clutch Systems (BCS) . . . . .	8
Handles and Control Cables . . . . .	9
Self-Propel Belt Replacement . . . . .	10

# SINGLE SPEED SPUR/BEVEL GEAR TRANSMISSION

## GEAR CASE ASSEMBLY

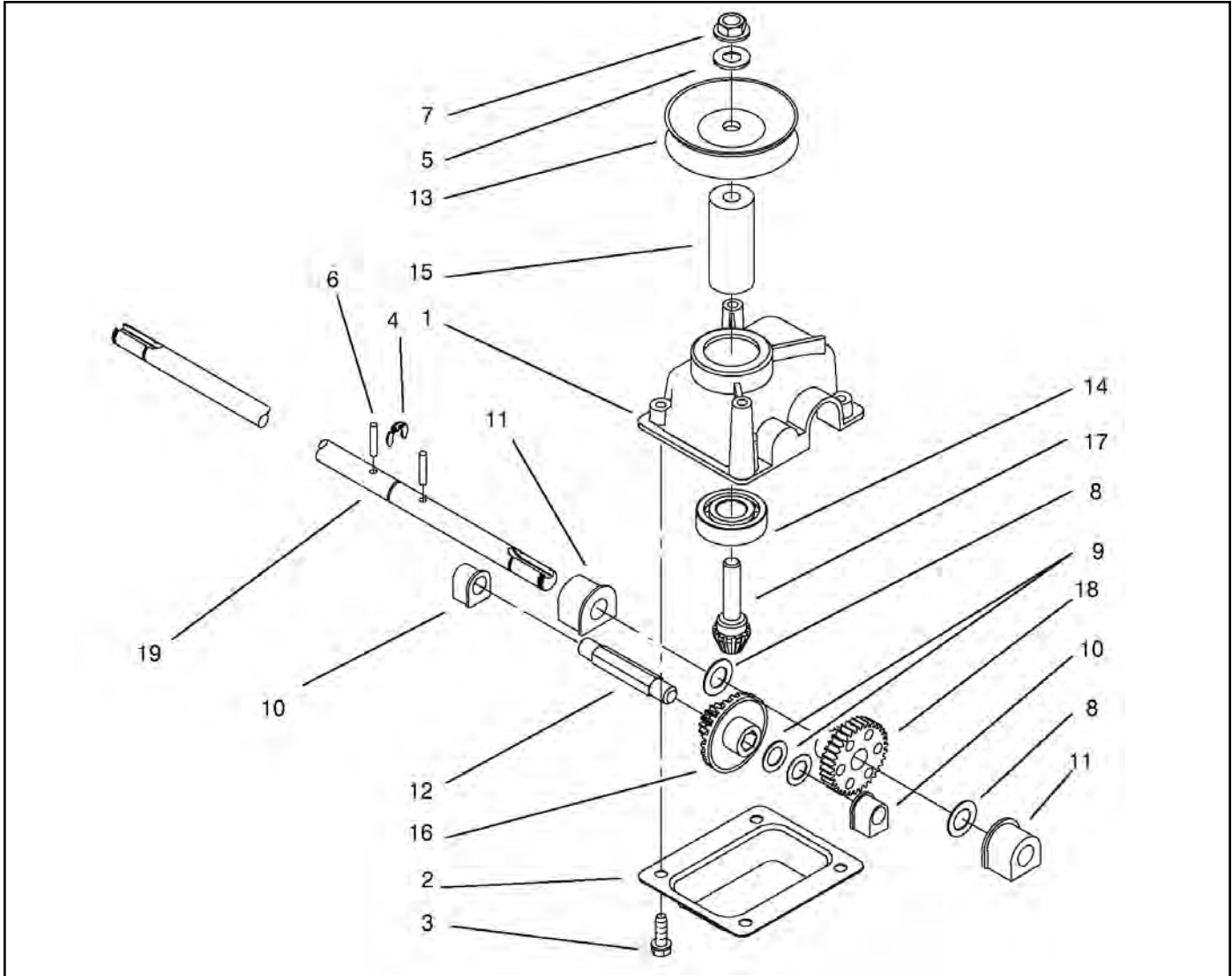

Fig 026

snglspspurbvlgearbox

Ref. No.	Qty	Description
1	1	Gear Case Casting
2	1	Gear Case Cover
3	1	HWH Screw
4	1	Retaining Ring
5	2	Flat Washer
6	2	Groove Pin
7	2	Lock Nut NI
8	2	Washer
9	1	Thrust Washer
10	1	Bushing

Ref. No.	Qty	Description
11	2	Output Bushing
12	1	Intermediate Shaft
13	1	Pulley Half
14	2	Ball Bearing
15	2	Pulley Spacer
16	2	Bevel Gear 15t Spur, 37t
17	2	Pinion Gear Bevel
18	2	Gear
19	2	Output Shaft



# SINGLE SPEED SPUR/BEVEL GEAR TRANSMISSION

## Description

This basic transmission has been in use for several years. There are minor variations, such as different shafts on the bevel pinion gear to accommodate belt alignment on different chassis. All use a bevel pinion input gear which mates with a combination bevel/spur gear, which drives a final spur gear.

## Lubrication

Proper lubrication for this transmission is 2.5 – 3 fluid ounces (7.1cc – 9.0cc) of lithium based No. 2 grease.

## Transmission Removal and Replacement

1. Raise the rear of the mower and support with a block (Fig. 027).

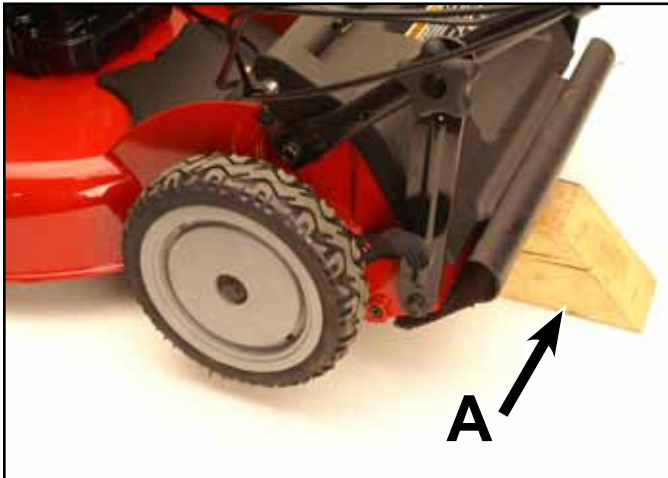

Fig 027

PICT-1870

A. Wood block

2. Remove transmission belt cover.
3. Remove both rear wheels.
4. Remove retaining ring, spring, thrust washer, and pinion from both axles (Fig. 028). Refer to “Wheel Pinion Clutch” on page 5-3 for additional information about the clutch mechanism.



Fig 028

PICT-1873a

5. Continue disassembly, remove rocking key, clutch washer, clip ring, keyed thrust washer, pivot arm thrust washer, and friction ring. The pivot arm and spring arm will then slide off the axle (Fig. 029).



Fig 029

PICT-1874a

# SINGLE SPEED SPUR/BEVEL GEAR TRANSMISSION

6. Remove the belt guide. Note the location of the spacer under the front mounting screw (Fig. 030). Do not try to force the belt off the pulley without removing the belt guide. This often results in damage to the belt or slightly bending the belt guide, causing an increased tendency for belt jumping.



Fig 030 PICT-1880a

On some models, removing these 2 screws makes transmission removal easier (Fig. 032).

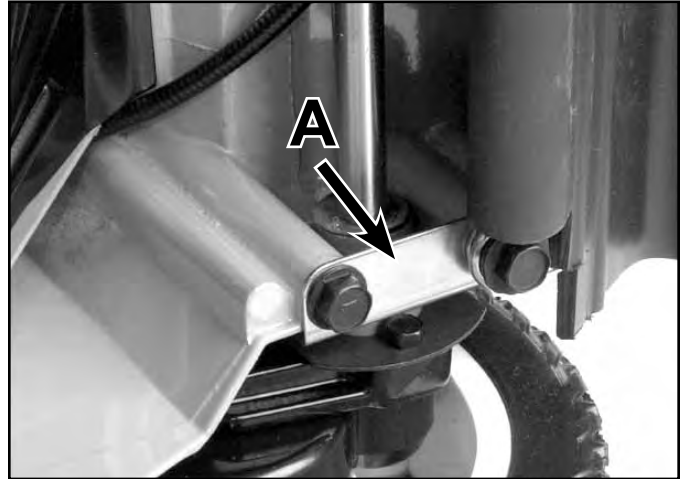

Fig 032 3428-0121

A. End cap

7. The transmission can be moved to the right until the short end of the axle clears the housing and the transmission can be removed (Fig. 031). Some models have the axle shaft retained by an end cap.



Fig 031 3428-0074

## Transmission Internal Repair

The nut on the pulley can be removed now. The spacer under the pulley varies with the chassis and the length of the shaft on the pinion (Fig. 033). Remove the self-tapping screws holding the cover on the transmission.



Fig 033 3428-0008

# SINGLE SPEED SPUR/BEVEL GEAR TRANSMISSION

Before removing the parts from the case, note the quantity and location of the thrust washers (Fig. 034).

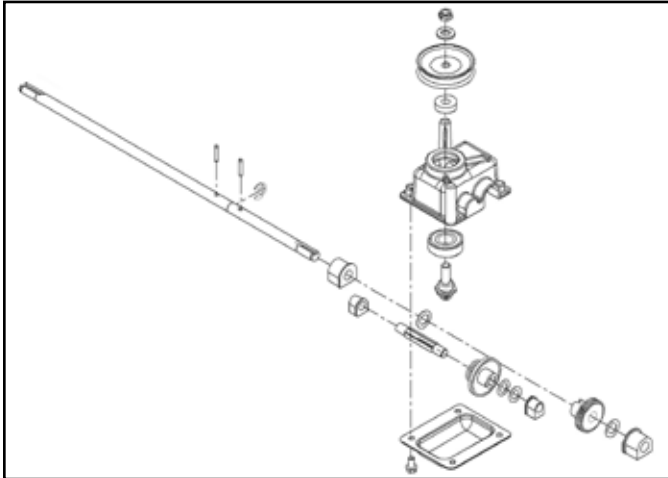

Fig 034

108-8140-1b

Remove the axle and intermediate shaft with the gears. The bearing in the cover should be sealed on both sides. Inspect the bearing and its seals for damage (Fig. 035). Replace as necessary. The bearing is pressed into the cover. Make sure bearing is fully seated.

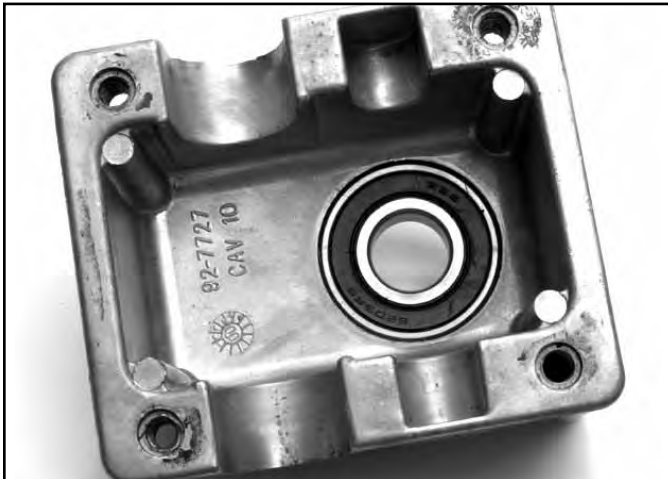

Fig 035

3428-0018

Clean the gears in solvent and inspect carefully. Any damaged gear must be replaced. Also replace the mate for the damaged gear. When gears run together, they develop a wear pattern that will result in premature failure if only one gear is replaced. The exception for this is if the transmission has VERY little running time before failure.

The axle has two roll pins through it. One connects the single spur gear to the axle (Fig. 036). The other pin aligns the axle and transmission case.



Fig 036

3428-0016

# SINGLE SPEED SPUR/BEVEL GEAR TRANSMISSION

## Assembly

Assemble with the correct number of thrust washers. Refer to the parts manual if there is any doubt at all. It is not possible to locate the shafts and bearings in the wrong location, due to differences in sizes.

Prior to installation of oil impregnated bushings, it is wise to apply a light coating of engine oil to the running surface (Fig. 037). Add grease and install the cover.



Fig 037

3428-0019

Finally, install the spacer and pulley on the input shaft. The internal gears will help hold the pinion while the nut is tightened (Fig. 038).

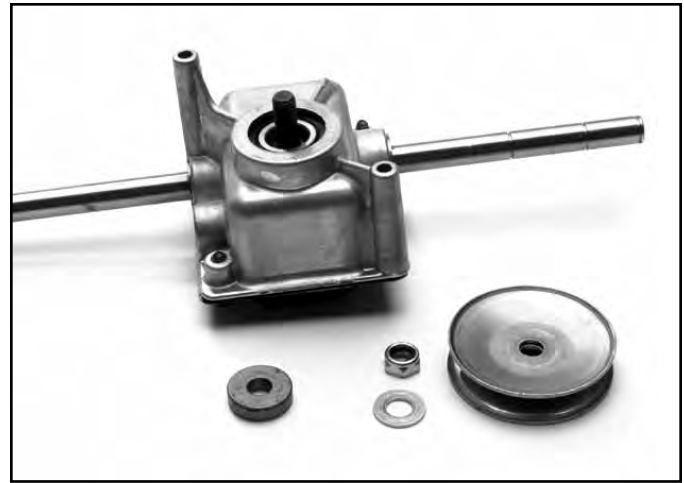

Fig 038

3428-0022

Insert the transmission back into the chassis. Refer to the section on the wheel pinion clutch for assembly instructions.

Install self-propel cable. Adjust as needed; see "Handles and Control Cables" Section 7.

# **SINGLE SPEED BEVEL GEAR TRANSMISSION**

---

Safety Information . . . . .	1
Worm Drive Transmission . . . . .	2
Single Speed Spur/Bevel Gear Transmission . . . . .	3
<b>Single Speed Bevel Gear Transmission . . . . .</b>	<b>4</b>
Three Speed Transmission . . . . .	5
General Transmissions® . . . . .	6
Wheel Pinion Clutch . . . . .	7
Blade Brake Clutch Systems (BBC), Blade Override System (BOS), Blade Clutch Systems (BCS) . . . . .	8
Handles and Control Cables . . . . .	9
Self-Propel Belt Replacement . . . . .	10

# SINGLE SPEED BEVEL GEAR TRANSMISSION

## EXPLODED VIEW - SINGLE SPEED BEVEL GEAR TRANSMISSION

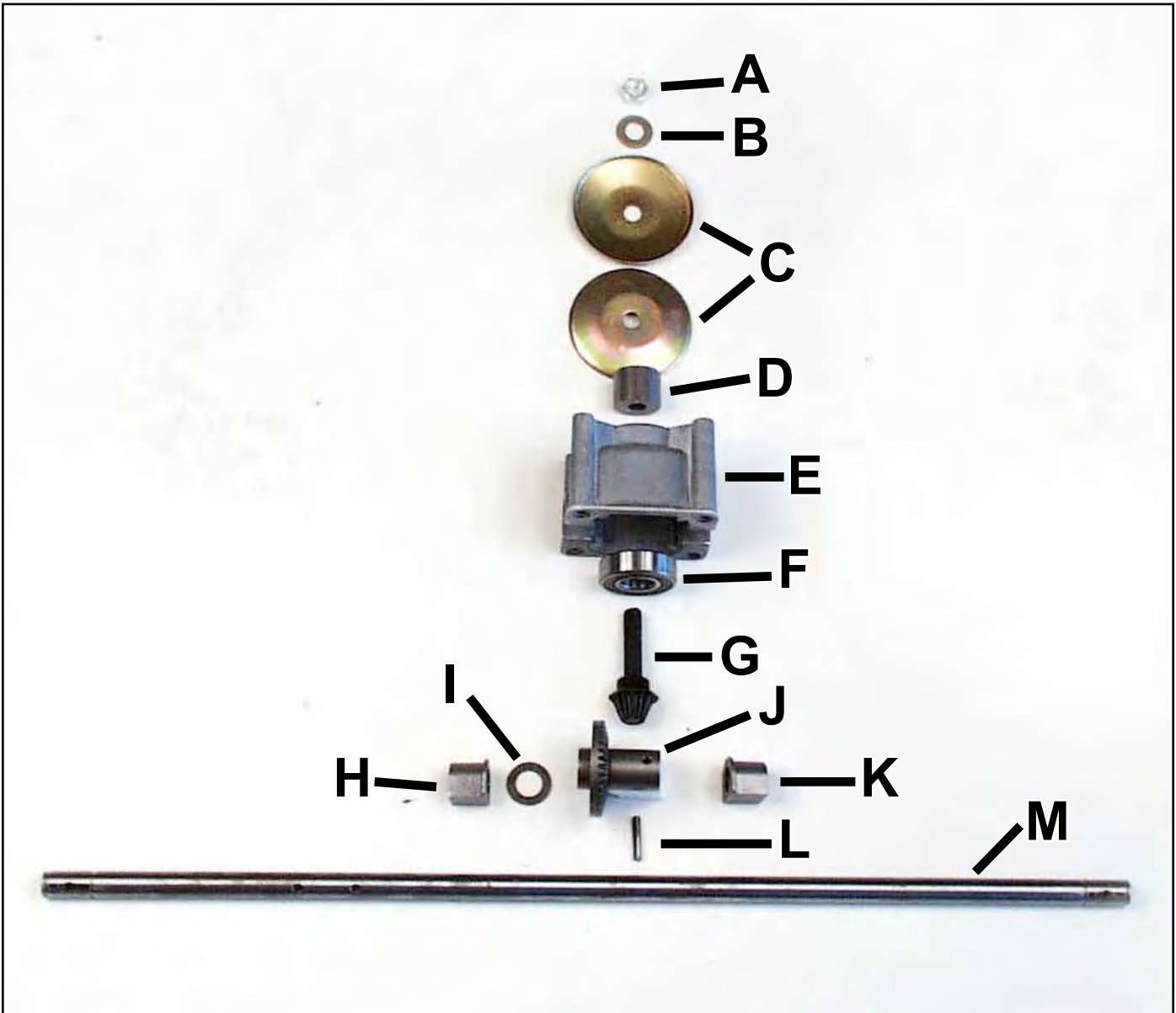

Fig 039

single speedtrans a

- |            |                  |
|------------|------------------|
| A. Nut     | H. Bushing       |
| B. Washer  | I. Thrust washer |
| C. Pulley  | J. Bevel Gear    |
| D. Spacer  | K. Bushing       |
| E. Housing | L. Roll pin      |
| F. Bearing | M. Axle          |
| G. Pinion  |                  |

# SINGLE SPEED BEVEL GEAR TRANSMISSION

## GENERAL INFORMATION

This transmission was first used on 22" steel deck models for 2002. It is used in both front wheel and rear wheel drive configurations. The bevel gear is reversed when used in the front drive versus the rear drive to change axle shaft direction of rotation.

In both cases, the gears are in constant mesh. Clutching is done by rocking the transmission to tighten or loosen the drive belt (Fig. 040). The control cable will move the transmission to tighten the belt. When released, the weight of the transmission causes it to rock towards the engine to disengage.

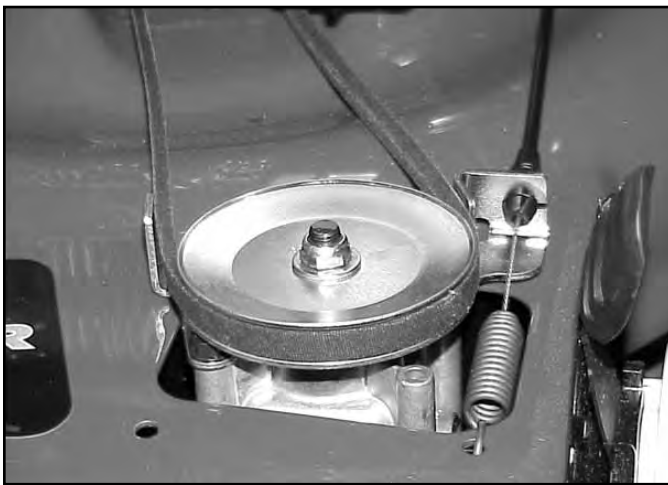

Fig 040

MVC-485

# SINGLE SPEED BEVEL GEAR TRANSMISSION

## FRONT AXLE AND TRANSMISSION ASSEMBLY

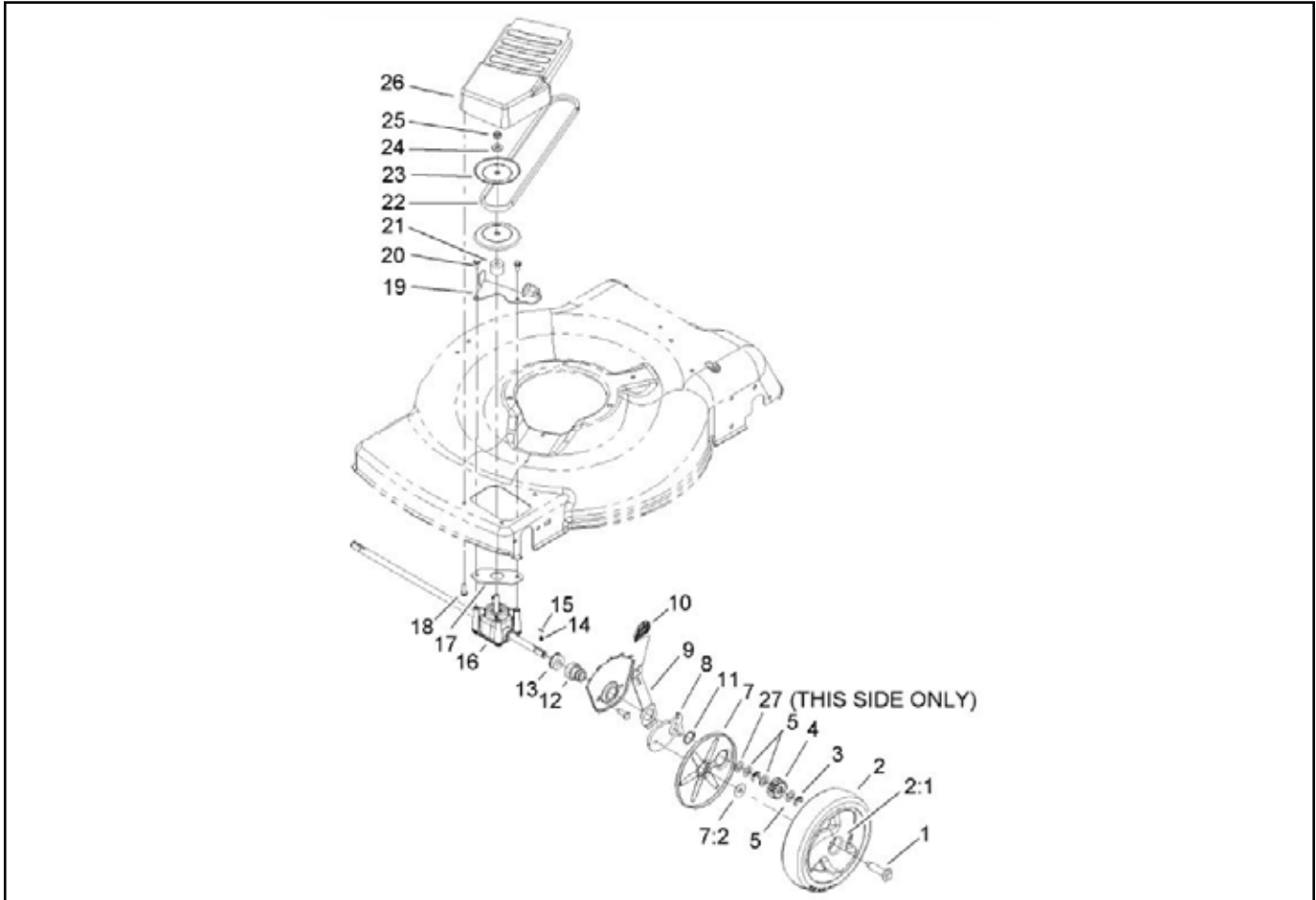

Fig 041

3354-613\_5

Ref. No.	Qty	Description
1	2	Bolt-Shoulder
2	2	Wheel Gear ASM
2:1	2	Bushing
3	4	Klipring-Locking
4	2	Gear-Pinion, 13T
5	6	Washer-Thrust
7	2	Cover-Wheel
7:1	1	Cover
7:2	1	Washer-Stepped
8	2	Arm-Pivot, Front
9	2	Arm-Spring
10	2	Knob-Lever, HOC
11	2	Ring-Retaining
12	2	Retainer-Bearing, HOC
13	2	Bearing-Ball

Ref. No.	Qty	Description
14	2	Spring-Compression
15	2	Key
16	1	Transmission ASM
17	1	Gasket-Gearbox
18	2	Screw-HWH
19	1	Bracket-Pivot, Fwd
20	2	Screw-HWH
21	1	Spacer
22	1	V-Belt
23	2	Pulley-Half, Front
24	1	Washer-Flat
25	1	Nut-Lock
26	1	Cover-Belt, Front
27	1	Washer



# SINGLE SPEED BEVEL GEAR TRANSMISSION

## 22" FRONT WHEEL DRIVE MODELS

### Remove Transmission

1. Block the front of the mower up. There are two screws that secure the belt cover to the housing. They are accessed from the bottom (Fig. 042).

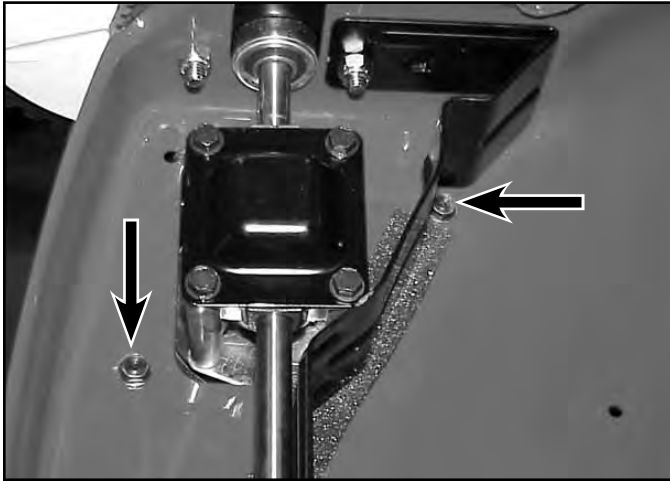

Fig 042

MVC-482

2. Slip the belt out between the transmission pulley and belt guide.
3. Grip the axle with locking pliers and remove the locknut on the transmission pulley (Fig. 043).



Fig 043

MVC-486

4. Remove the nut, washer, transmission pulley halves, and spacer.
5. Remove the belt guide.
6. Remove both front wheels; note there is a washer between the wheel and wheel cover.
7. To remove the wheel pinions, remove the clip ring and thrust washer. The pinion will now slide off the axle (Fig. 044).

**Note:** The spring-loaded drive key is under the pinion.

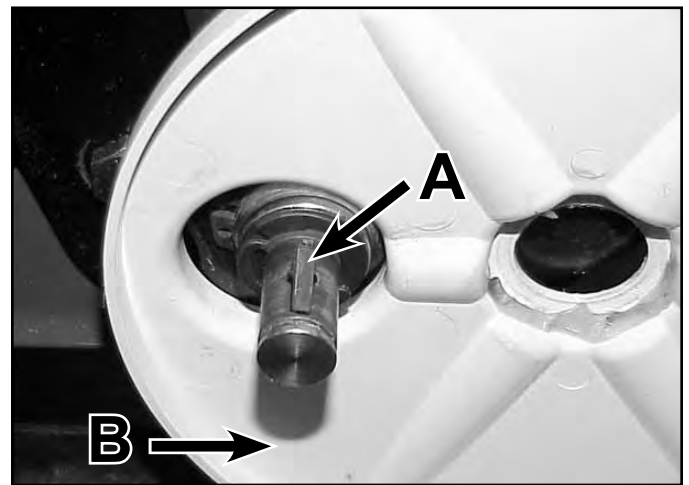

Fig 044

MVC-472

A. Key

B. Wheel cover

8. Remove the wheel cover.

# SINGLE SPEED BEVEL GEAR TRANSMISSION

9. Remove the two bolts and nuts securing each pivot arm to the housing. There is a notch in the pivot arm for clearance of a socket (Fig. 045).

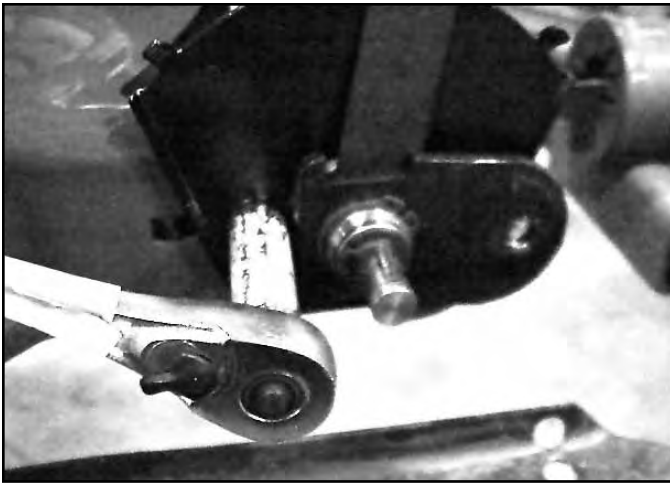

Fig 045

MVC-475a

10. Remove the clip ring and thrust washer from each end of the axle (the left side has 2 thrust washers, the right side, one). The bearing, bearing retainer, HOC plate, spring arm and pivot arm all come off as one unit (Fig. 047).



Fig 047

PICT-1858a

The axle assembly will now drop out of the chassis (Fig. 046).



Fig 046

PICT-1857a

11. To disassemble the pivot arm assembly, compress the components with two clamps or locking pliers (Fig. 048).



Fig 048

MVC-478

# SINGLE SPEED BEVEL GEAR TRANSMISSION

The snap ring can now be removed. Loosen the clamps with care due to the spring arm tension. Separate the spring arm components (Fig. 049).



Fig 049

PICT-1869a

## Transmission Disassembly

1. Remove the 4 screws holding the cover onto the transmission. The axle, bearings, and bevel gear can be lifted out (Fig. 050).

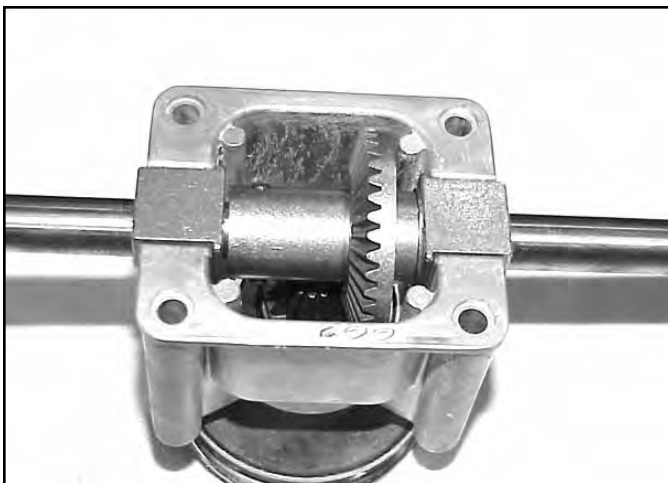

Fig 050

MVC-462

2. Since the pulley was previously removed, the input shaft will now slip out of the transmission case.
3. If the input bearing is to be removed, press it out of the case now.
4. Slide the bearings and thrust washer off the axle. Drive the roll pin out and the bevel gear can be removed (Fig. 051).

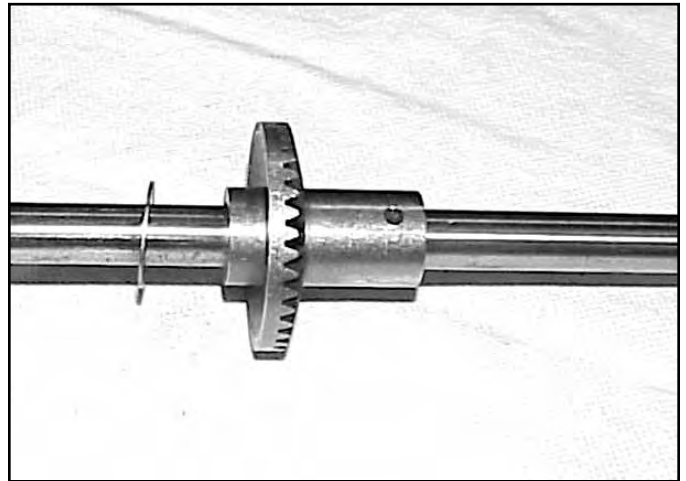

Fig 051

MVC-468

## Transmission Assembly

Assemble in reverse order.

*See Assembly Tips next page.*

# SINGLE SPEED BEVEL GEAR TRANSMISSION

## Assembly Tips

1. The same axle is used for both front and rear drive versions. There are two holes in the axle about one inch apart. Front wheel drive transmissions use the hole in the axle that is about 5 3/4" (14.6cm) from the end or closest to the center of the axle (Fig. 052).

Slip the gear on such that the teeth and longest hub face the longer end of the axle. Drive the pin into place. A double check is that neither of the pin holes should be visible when the gear is installed.

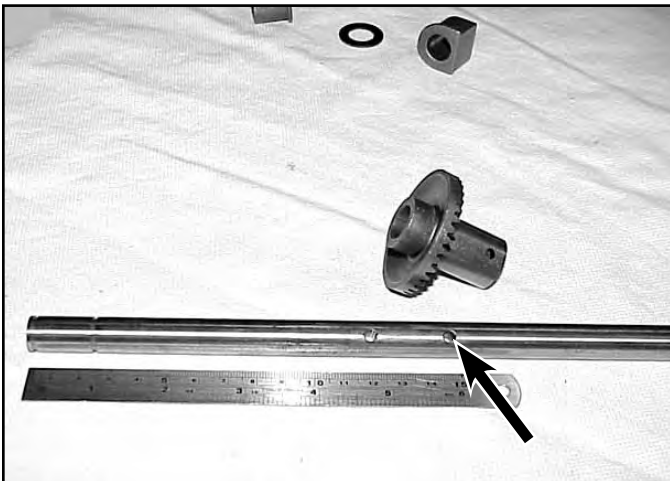

Fig 052

MVC-466

2. Install the trust washer on the side of the gear with the shorter hub, away from the gear teeth (Fig. 053).

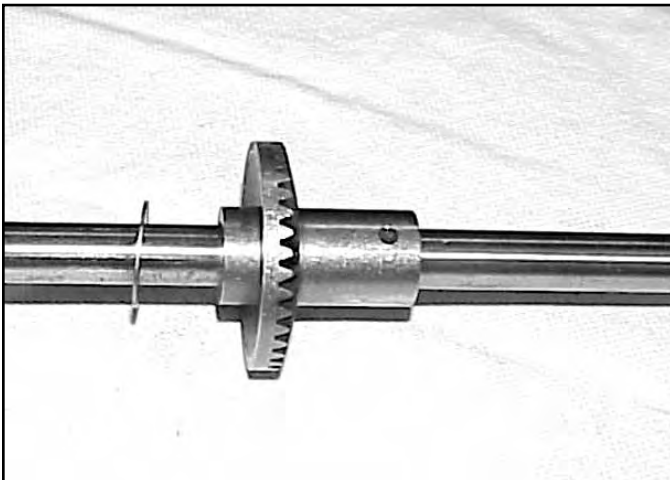

Fig 053

MVC-468

3. Install the transmission bearings with the flange facing the gear (Fig. 054).

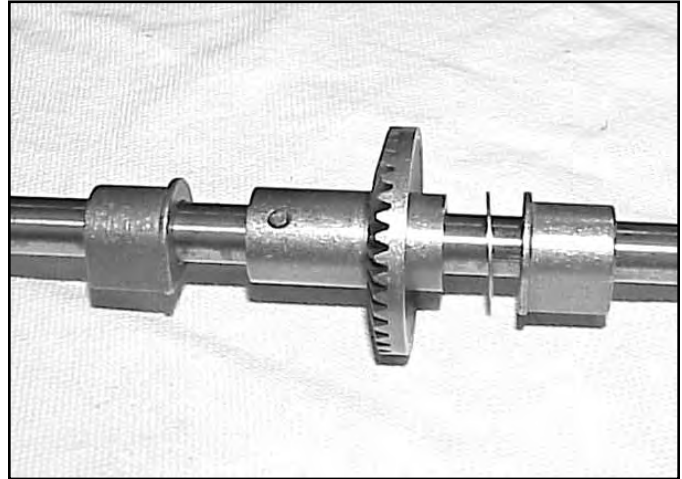

Fig 054

MVC-470

4. If the input bearing was removed, press the new one in until it bottoms in the case.
5. Fill the transmission case approximately 2/3 full with #2 lithium base grease.
6. Assemble the bearing, bearing retainer, height of cut plate, spring arm and pivot arm. Use two clamps or vise grips to compress the assembly so the snap ring can be installed.

**Note: Install the snap ring with the sharp edge facing away from the spring arm.**

# SINGLE SPEED BEVEL GEAR TRANSMISSION

7. Coat the axle, key, and spring with #2 molybdenum disulfide base grease or anti-seize compound before installing the pinion (Fig. 055).



Fig 055

MVC-472

8. The wheel pinion is marked with an R and L for right and left. Identify right and left from the operator's position (Fig. 056). On the right side, the letter R should face out. The letter L should face out on the left side. If the wheel pinions are reversed, the wheels will not drive.



Fig 056

MVC-474

**Note:** For more information on the wheel clutch see Section 5, Wheel Pinion Clutch.

## Belt Service - Front Wheel Drive Models

To replace the self-propel drive belt, proceed as follows:

1. Drain the fuel and oil and tip the mower on its right side.
2. Remove the two screws securing the belt cover from under the housing (Fig. 057).

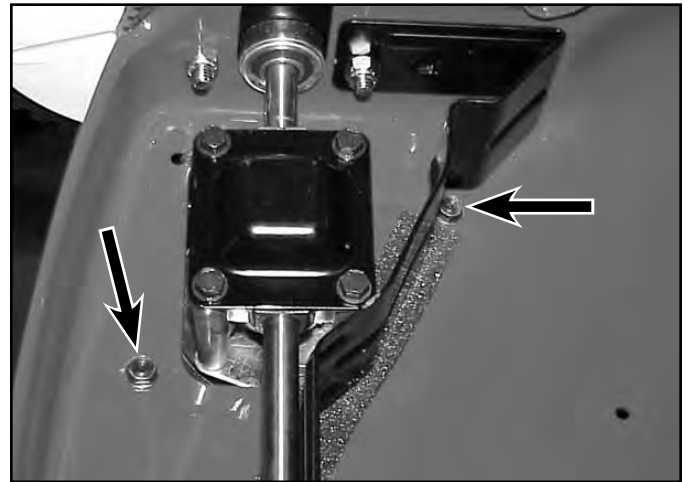

Fig 057

MVC-482

3. Slip the belt off the transmission pulley and push it towards the engine (Fig. 058).



Fig 058

MVC-487

# SINGLE SPEED BEVEL GEAR TRANSMISSION

4. Remove one of the mounting screws for the belt guide and loosen the other. DO NOT bend the belt guide (Fig. 059).

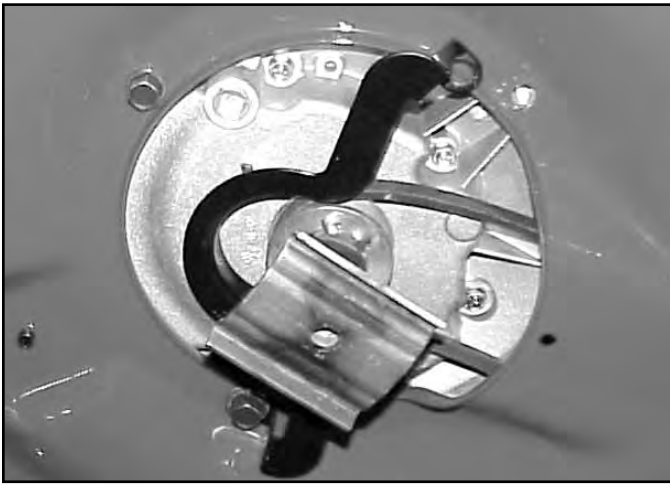

Fig 059

MVC-490

**Note:** Blade removed for clarity. The blade can be removed, but it is not required for belt replacement.

5. Slip the belt out of the crankshaft pulley and over the blade (Fig. 060).

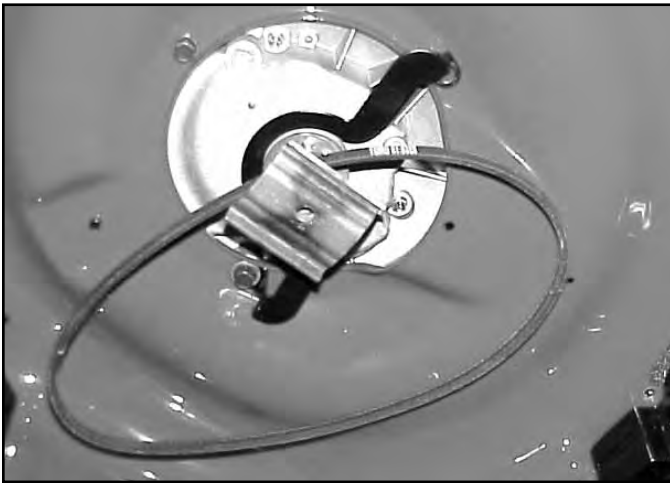

Fig 060

MVC-491

## 22" TORO & LAWN-BOY REAR WHEEL DRIVE MODELS

### Transmission Removal and Belt Replacement

On rear wheel drive models, it is necessary to separate the rear drive assembly from the mower housing in order to change the drive belt.

1. Drain fuel and oil from the engine.
2. Remove the single retaining screw from the center of the bag door spring. Slide the door to one side and remove it from the rear HOC side plates (Fig. 061).

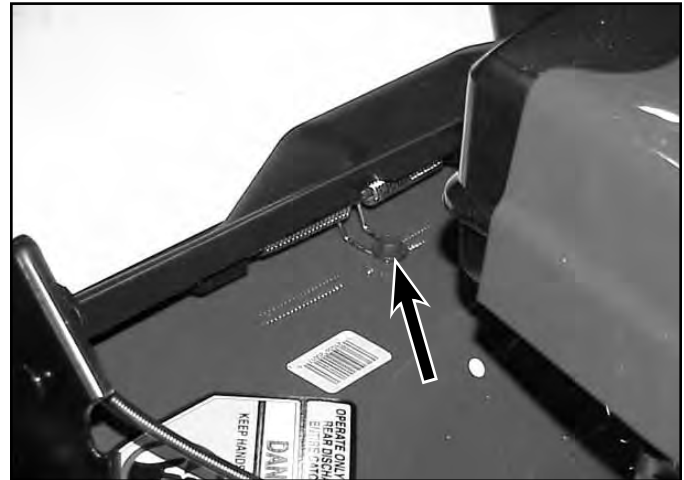

Fig 061

MVC-733

# SINGLE SPEED BEVEL GEAR TRANSMISSION

3. Remove the plug from the hole next to where the self-propel cable goes through the chassis (Fig. 062).

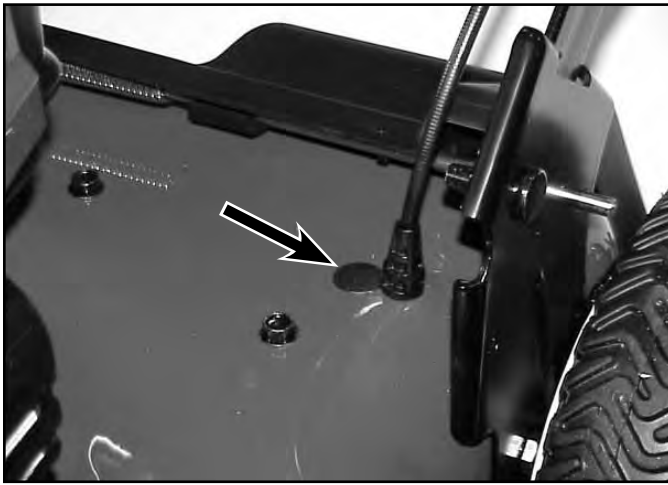

Fig 062

MVC-735

4. Tip the mower on its side. The cable snaps in from the top and connects to an arm on the transmission belt guide (Fig. 063).

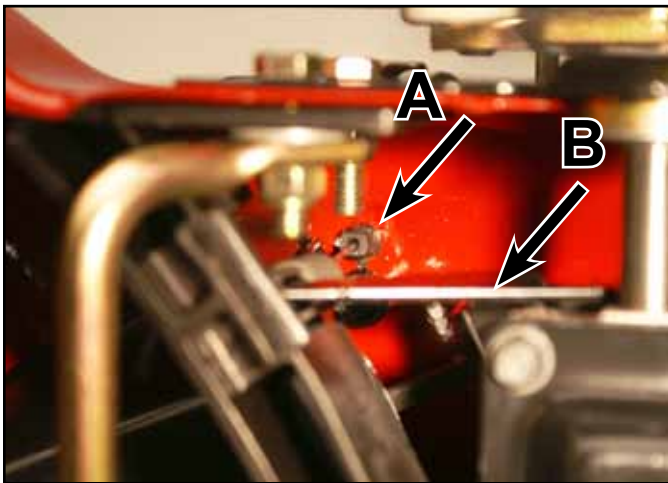

Fig 063

PICT-1884a

A. Cable

B. Belt guide

5. The cable tool (P/N 105-6819) will compress the locking tabs on the cable so it can be removed from the housing.
6. Slide the cable tool over the end of the cable and push (Fig. 064). At the same time, reach around the mower and pull the cable out of the housing.



Fig 064

PICT-1895a

A. Cable tool

7. With the plug removed from the larger hole next to the cable, move the cable through the slot (Fig. 065).



Fig 065

PICT-1904

# SINGLE SPEED BEVEL GEAR TRANSMISSION

8. Push it into the larger hole (Fig. 066).



Fig 066

PICT-1897

9. Remove both rear wheels and both wheel covers.

10. Remove the stop cable from the engine (Fig. 067) and disconnect the self-propel cable spring from the transmission.

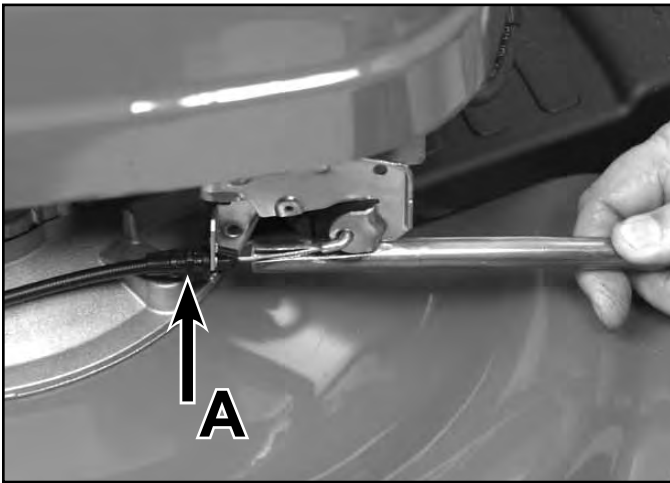

Fig 067

DSC-017

A. Stop cable

11. Pinch the ends of the lower handle together to disengage them from the pins on the HOC plates (Fig. 068).



Fig 068

MVC-737

12. Tip the mower onto its right side (carburetor up) and remove the blade.

13. Remove one of the belt guide screws and loosen the other enough to pivot the guide away (Fig. 069). Do not bend the belt guide. Slide the pulley/blade adapter and belt off the crankshaft.



Fig 069

MVC-738



# SINGLE SPEED BEVEL GEAR TRANSMISSION

14. Place the mower right side up and remove the three hex head and one Allen head cap screws on each side that hold the height of cut plates to the chassis (Fig. 070). The transmission assembly will now drop down.

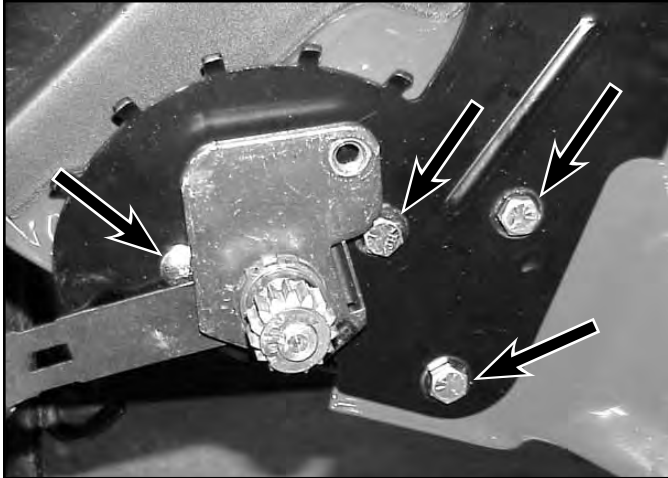

Fig 070

MVC-848

15. There is a cross brace underneath the mower that is held in place by two of the cap screws shown above (Fig. 071).

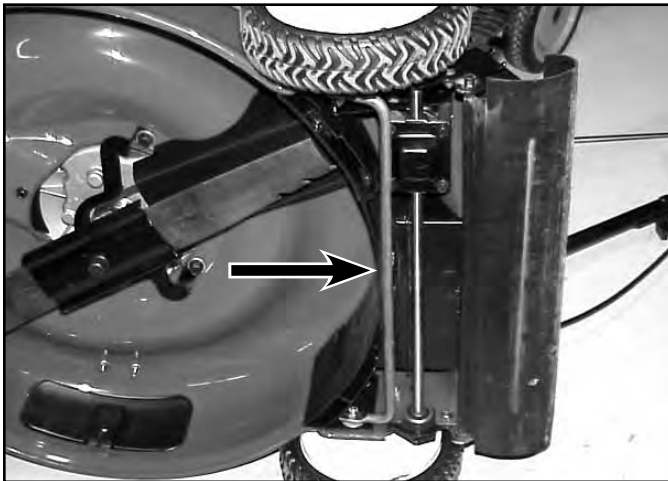

Fig 071

MVC-852

16. The belt cover must be removed in order to remove the belt (Fig. 072).

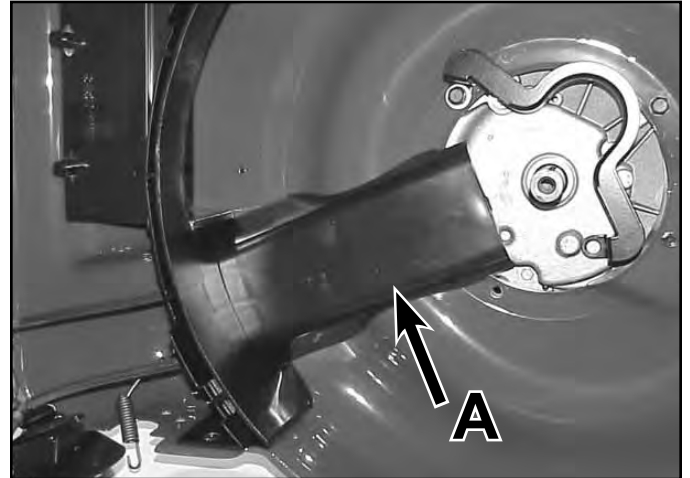

Fig 072

MVC-743

A. Belt cover

17. Remove 3 screws that secure the belt cover to the housing (Fig. 073).

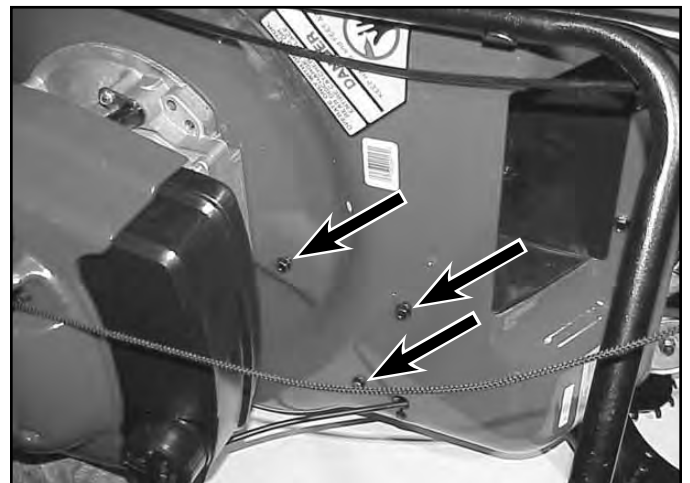

Fig 073

MVC-744

# SINGLE SPEED BEVEL GEAR TRANSMISSION

18. Pull the belt cover out from under the rear wall and the belt is exposed (Fig. 074).

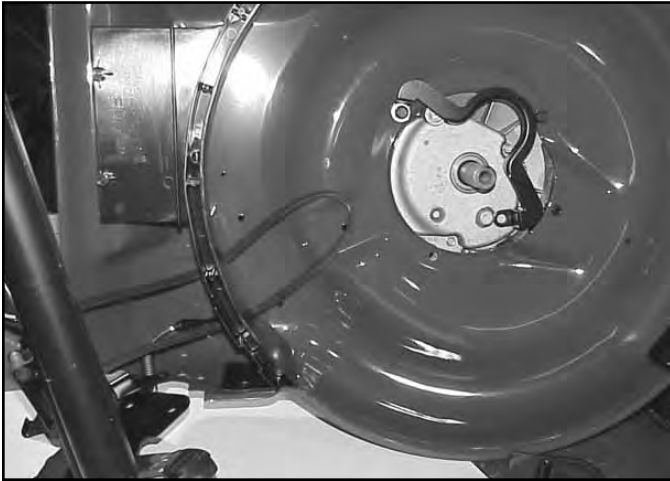

Fig 074

MVC-745

19. Clamp the axle with locking pliers and remove the pulley nut and transmission pulley (Fig. 075). Do not bend the belt guide. The pulley must be lifted up slightly to slip the belt off.



Fig 075

MVC-740

20. The cable may be unhooked from the arm on the transmission to help prevent cable damage (Fig. 076).

**Note:** It is not necessary to remove the transmission to replace the control cable.

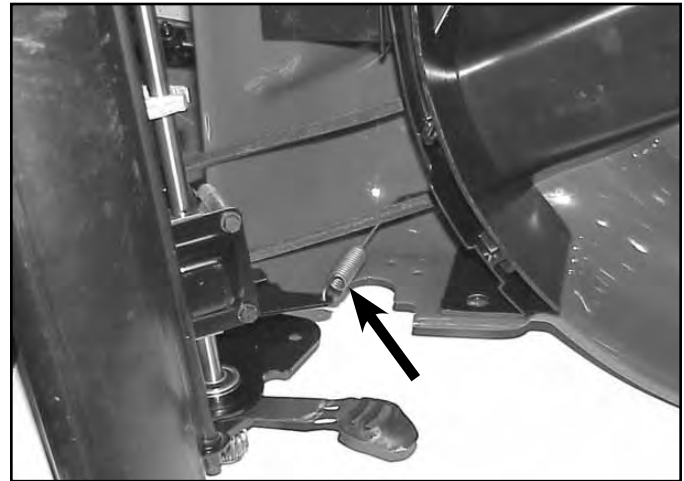

Fig 076

MVC-741

21. Pull the belt towards the crankshaft and remove.

**If only the belt is to be replaced, install a new one now. Reverse the process to assemble.**

**If transmission service is necessary proceed as follows.**

# SINGLE SPEED BEVEL GEAR TRANSMISSION

## Rear Axle Disassembly

1. Remove the clip rings and thrust washers that secure the pinions to the axle (Fig. 077).

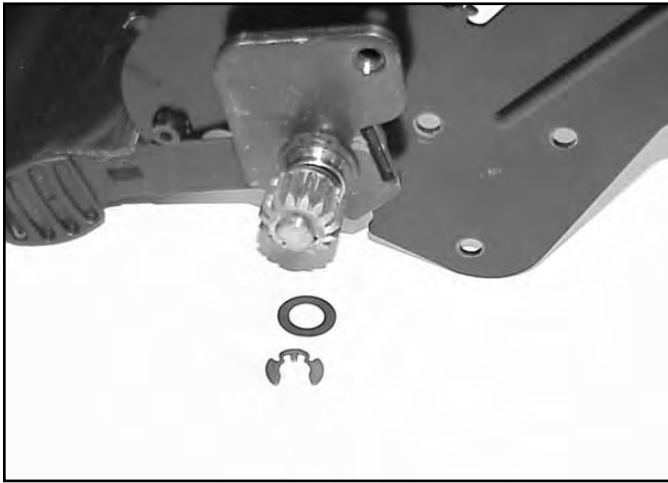

Fig 077

MVC-746

2. When removing the pinions, note that there is a spring-loaded key under them.
3. Remove the other thrust washer and retaining ring holding the pivot assembly to the axle (Fig. 078).

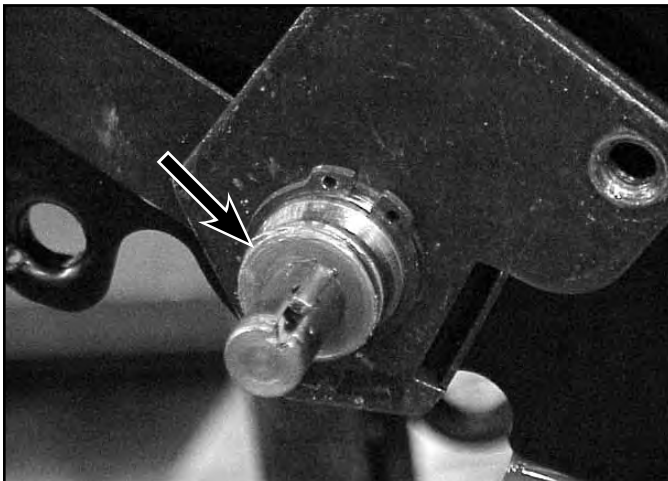

Fig 078

MVC-850

4. The pivot assembly will slide off the axle. This includes the bearing, bearing retainer, HOC plate, spring arm, and pivot arm (Fig. 079).



Fig 079

MVC-747

5. Clamp the pivot assembly with 2 pairs of locking pliers or other clamps and remove the snap ring (Fig. 080).



Fig 080

MVC-748

# SINGLE SPEED BEVEL GEAR TRANSMISSION

6. You can now release the clamps and separate the HOC plate, spring arm, and pivot arm (Fig. 081).



Fig 081

MVC-750

2. Since the pulley was previously removed, the input shaft will now slip out of the transmission case.
3. If the input bearing is to be removed, press it out now.
4. Slide the bearings and thrust washer off the axle. Drive the roll pin out and the bevel gear can be removed (Fig. 083).

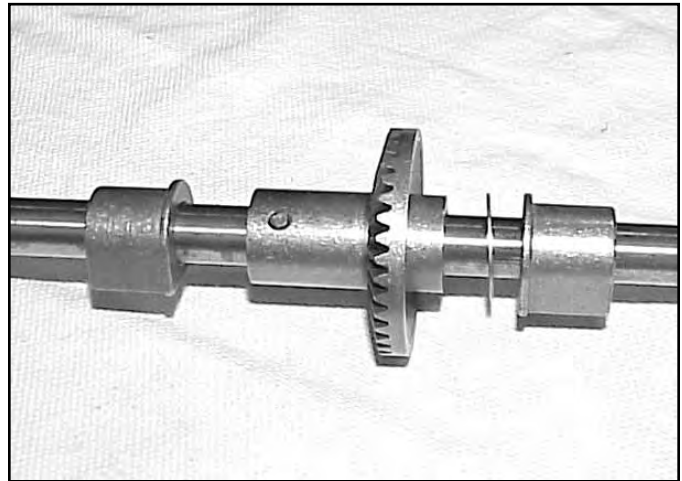

Fig 083

MVC-470

## Transmission Disassembly

1. Remove the 4 screws holding the cover on the transmission. The axle, bearings, and bevel gear can be lifted out (Fig. 082).

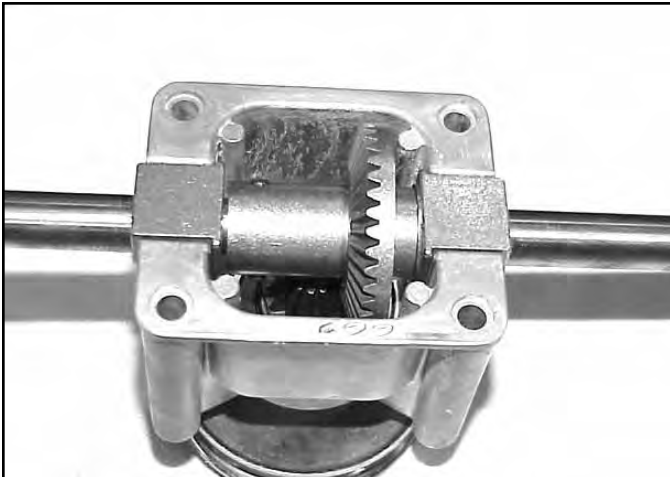

Fig 082

MVC-462

## Transmission Assembly

Assemble in reverse order.

# SINGLE SPEED BEVEL GEAR TRANSMISSION

## Axle Assembly Tips

1. The same axle is used for both front and rear wheel drive models. There are two holes in the axle about one inch apart.

Rear wheel drive models use the hole about 4-3/4" (12cm) from the end. Slip the gear on such that the teeth and the longest hub face the short end of the axle. Drive the pin into place. A double check is that neither of the pin holes should be visible when the gear is installed (Fig. 084).

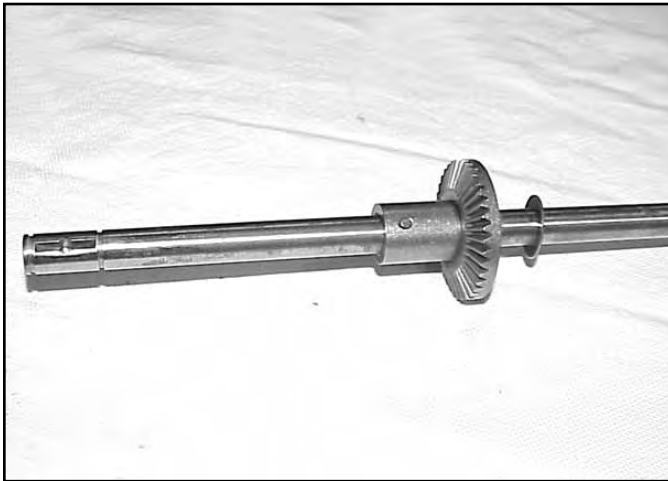

Fig 084

MVC-469

- A. Gear                      B. Thrust washer

2. Install the thrust washer on the side of the gear with the shortest hub, away from the gear teeth (Fig. 084).

3. Install the transmission bearings with the flange facing the gear (Fig. 085).

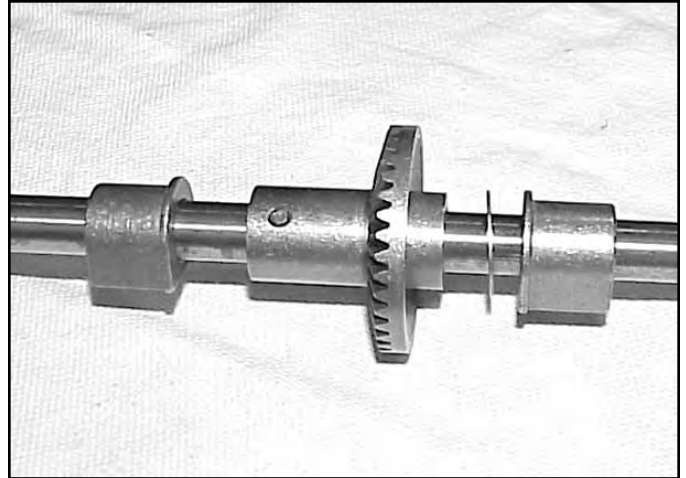

Fig 085

MVC-470

4. Fill the transmission approximately 2/3 full with #2 Lithium base grease (1.5 oz or 43gm).
5. Assemble the bearing, bearing retainer, HOC plate, spring arm, and pivot arm. Use two vise grips or clamps to compress the assembly so the snap ring can be installed (Fig. 086).

**Note:** Install the snap ring with the sharp edge facing away from the spring arm.



Fig 086

MVC-748

# SINGLE SPEED BEVEL GEAR TRANSMISSION

---

6. Coat the axle, key, and spring with #2 molybendum disulfide grease or anti-seize compound before installing the pinion (Fig. 087).



Fig 087

MVC-472

7. The wheel pinion is marked with an R and L for right and left. Identify right and left from the operator's position (Fig. 088). On the right side, the R should face outward. The letter L should face outward on the left side. If the wheel pinions are reversed, the wheels will not drive.

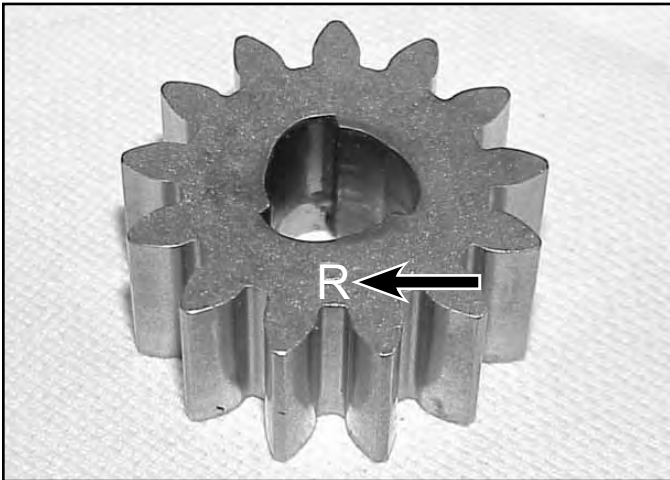

Fig 088

MVC-474

**Note:** See Chapter 5 for more information on Wheel Clutches.

# SINGLE SPEED BEVEL GEAR TRANSMISSION

## LAWN-BOY INSIGHT TRANSMISSION REMOVE AND REPLACE

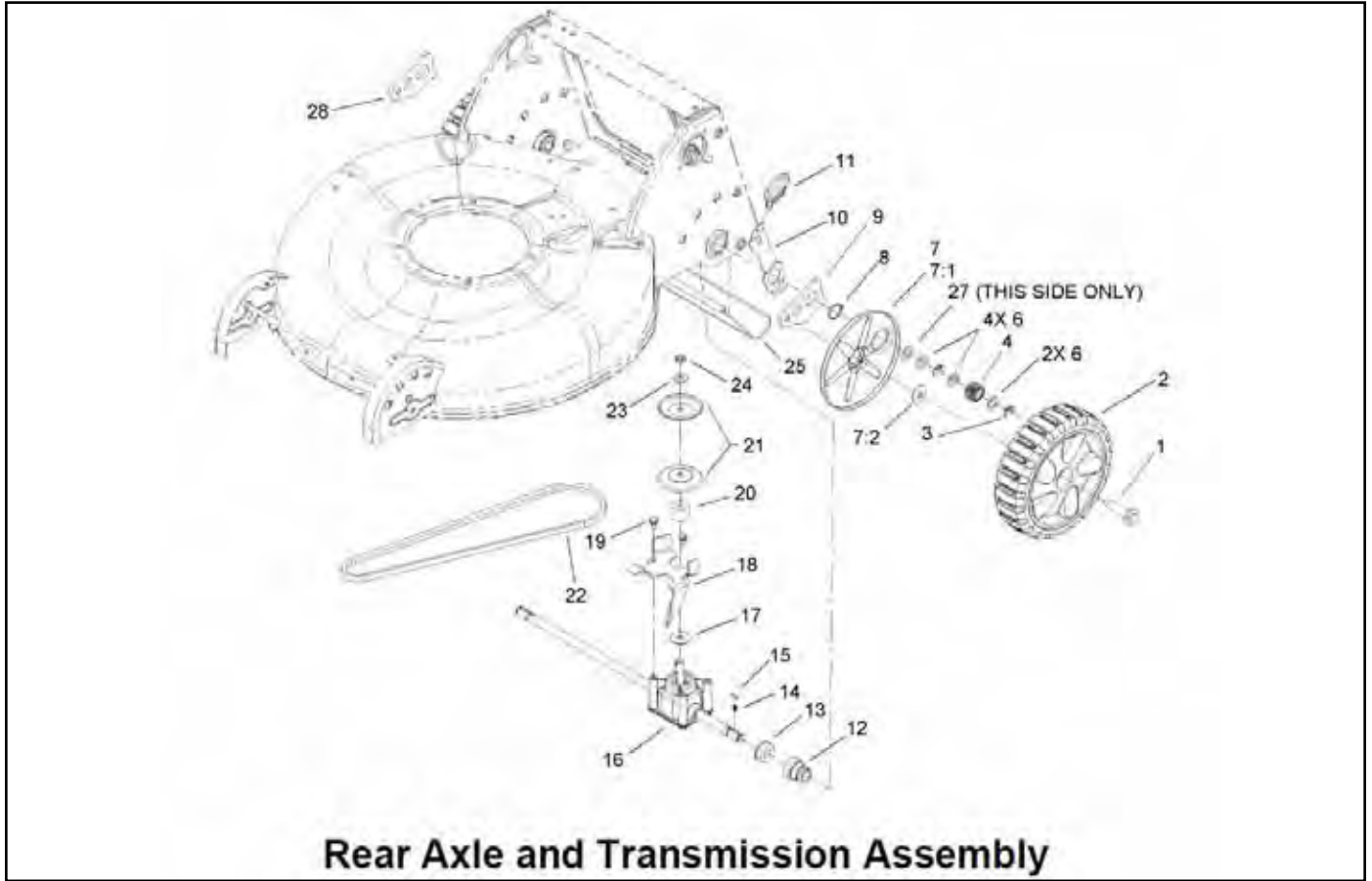

Fig 089

3352-960\_6

Ref. No.	Qty	Description
1	2	Bolt-Shoulder
2	2	Rear Wheel ASM
3	4	Klipring-Locking
4	2	Gear-Pinion, 15T
6	6	Washer-Thrust
7	2	Wheel Cover ASM
7:1	1	Cover-Wheel
7:2	1	Washer-Stepped
8	2	Ring-Retaining
9	1	Arm-Rear, Pivot, LH
10	2	Arm-Spring, Rear
11	2	Knob-Lever, HOC
12	2	Retainer-Bearing, HOC
13	2	Bearing-Ball

Ref. No.	Qty	Description
14	2	Spring-Compression
15	2	Key
16	1	Transmission ASM
17	1	Washer-Shield
18	1	Bracket-Transmission
19	2	Screw-HWH
20	1	Spacer
21	2	Pulley-Half
22	1	V-Belt
23	1	Washer-Flat
24	1	Nut-Lock
25	1	Shield-Trailing
27	1	Washer
28	1	Arm-Rear Pivot, RH

# SINGLE SPEED BEVEL GEAR TRANSMISSION

## Transmission Removal & Belt Replacement

The following steps will show one method of replacing the belt or removing the transmission on the Lawn-Boy Insight mowers.

1. Prepare the mower. Drain the gas and oil and disconnect the spark plug wire.
2. Remove two screws that secure the rear cover (Fig. 090).



Fig 090 MVC-285X

3. Remove the 3 belt cover screws (Fig. 091).

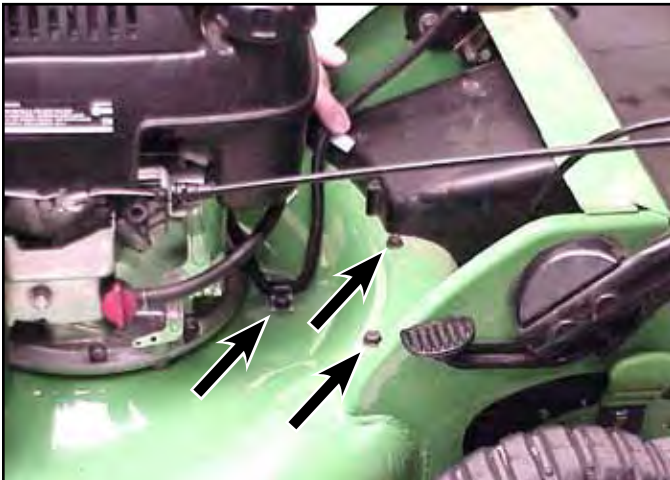

Fig 091 MVC-286Xa

4. The belt cover will drop off the bottom (Fig. 092).



Fig 092 MVC-288Xa

- A. Belt cover
5. If you have an electric start model, remove the battery and battery box.
6. Clamp the axle with a locking pliers and remove the nut from the transmission pulley. If you are using an air wrench, you may not need to hold the axle (Fig. 093).



Fig 093 MVC-291X



# SINGLE SPEED BEVEL GEAR TRANSMISSION

7. Lift the top half of the transmission pulley off. If just replacing the belt, push the belt into the cutting chamber and slip the belt over the blade. Reverse the process to install the new belt (Fig. 094).

**Note:** Do not get anti-seize on the belt or the drive will slip.



Fig 094

MVC-292X

9. Bend the trailing shield slightly in the middle and remove it from the mower. Rotate both rear spring arms down to disengage them from the mower housing (Fig. 096).



Fig 096

MVC-295Xa

**If the transmission is to be removed, continue:**

8. Support the back of the mower on a wood block and remove the rear wheels (Fig. 095).



Fig 095

MVC-294Xa

10. Remove clip ring, thrust washer, pinion, key spring and thrust washer (Fig. 097).

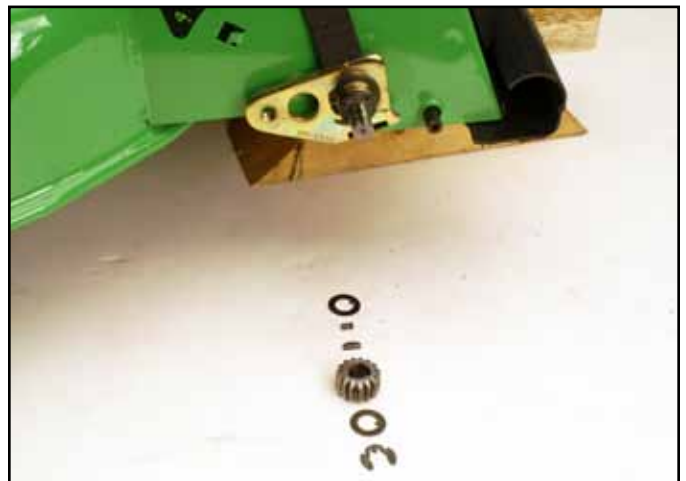

Fig 097

PICT-1914a

# SINGLE SPEED BEVEL GEAR TRANSMISSION

11. Remove clip ring, keyed thrust washer, and standard thrust washer (left side of mower has the standard thrust washer, right side does not) (Fig. 098).



Fig 098

PICT-1915a

13. Push the bearings and bearing retainers inward, towards the transmission (Fig. 100).



Fig 100

MVC-297Xa

12. Remove the snap ring, pivot arm and spring arm (Fig. 099).



Fig 099

PICT-1921a

14. Unhook the traction cable from the transmission belt guide (Fig. 101 and Fig. 102).



Fig 101

PICT-1923

# SINGLE SPEED BEVEL GEAR TRANSMISSION



Fig 102 MVC-211X1

15. Remove the nut, washer, 2 pulley halves, and spacer from the transmission input shaft. Remove 2 screws securing the belt guide to the transmission (Fig. 103).

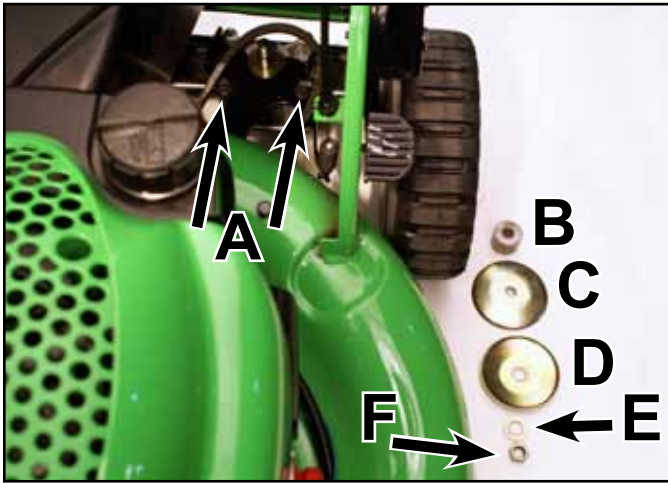

Fig 103 PICT-1926a

- |                                    |                |
|------------------------------------|----------------|
| A. 2 screws on top of transmission | D. Pulley half |
| B. Spacer                          | E. Washer      |
| C. Pulley half                     | F. Nut         |

16. Push the transmission to the left, as shown, and rotate to clear the tunnel. Drop the left side down, then pull the assembly out to the left side (Fig. 104).

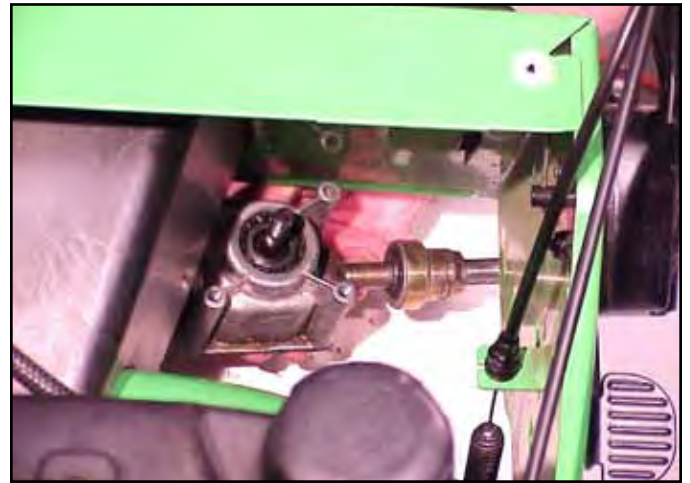

Fig 104 MVC-300X

17. The last step is to slide the bearings and bearing retainers off the axle (Fig. 105).

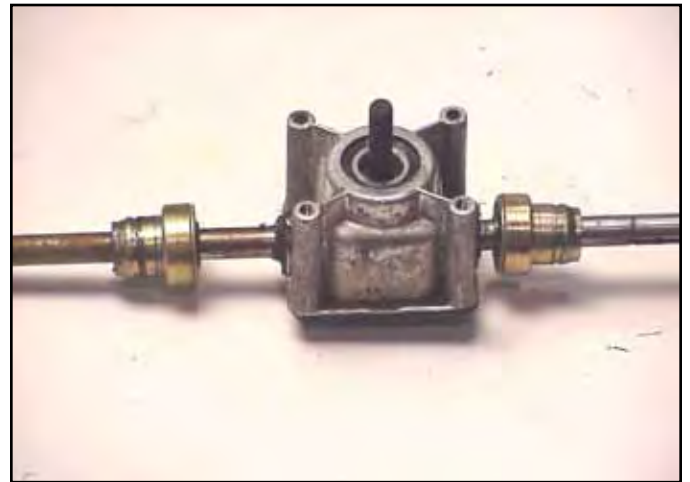

Fig 105 MVC-301X

# SINGLE SPEED BEVEL GEAR TRANSMISSION

## Transmission Disassembly

1. Remove the 4 screws holding the cover on the transmission. The axle, bearings, and bevel gear can be lifted out (Fig. 106).

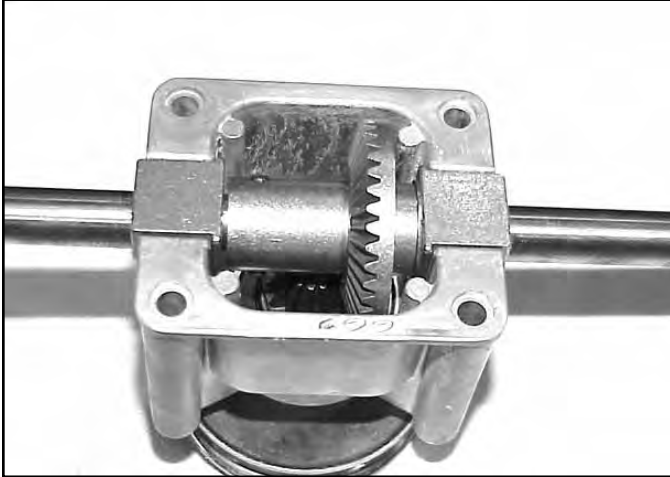

Fig 106

MVC-462

2. Since the pulley was previously removed, the input shaft will now slip out of the transmission case.
3. If the input bearing is to be removed, press it out now.
4. Slide the bearings and thrust washer off the axle. Drive the roll pin out and the bevel gear can then be removed (Fig. 107).

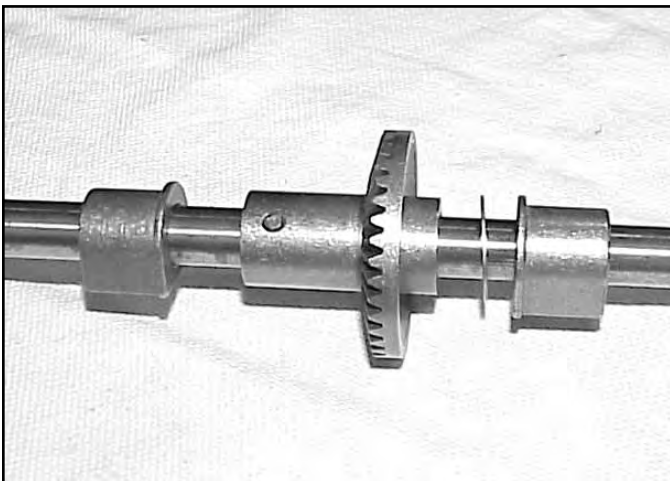

Fig 107

MVC-470

## Transmission Assembly & Installation

Assemble in reverse order. See Axle Assembly and Installation Tips following.

### Axle Assembly Tips

1. The same axle is used for both front and rear wheel drive models. There are two holes in the axle about one inch apart.

Rear wheel drive models use the hole about 4-3/4" (12cm) from the end. Slip the gear on such that the teeth and the longest hub face the short end of the axle. Drive the pin into place. A double check is that neither of the pin holes should be visible when the gear is installed (Fig. 108).

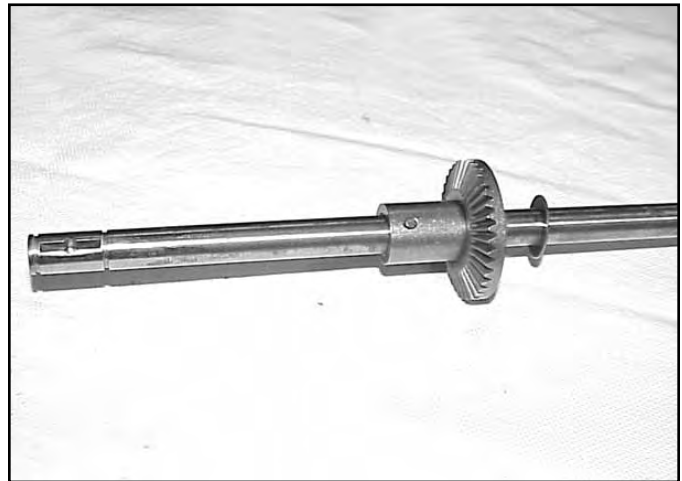

Fig 108

MVC-469

2. Install the thrust washer on the side of the gear with the shortest hub, away from the gear teeth (Fig. 108).

# SINGLE SPEED BEVEL GEAR TRANSMISSION

3. Install the transmission bearings with the flange facing the gear (Fig. 109).

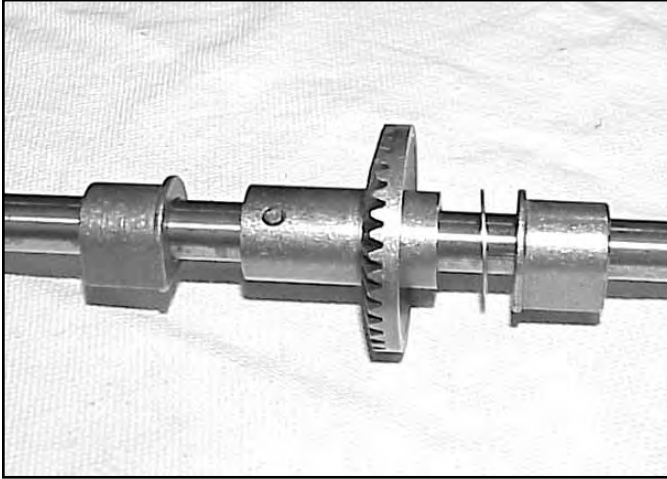

Fig 109

MVC-470

4. Fill the transmission approximately 2/3 full with #2 Lithium base grease (1.5 oz or 43gm).
5. Assemble the bearings and bearing retainers; install the transmission in the housing (Fig. 110).



Fig 110

MVC-301Xa

## Transmission Installation Tips

1. Reconnect the cable to the belt guide and install the washer and spacer before installing the guide on the transmission.
2. Install the snap rings and clip rings with the sharp side out (in the direction of the force). The left end of the axle uses the extra thrust washer, the one without the tab. Install the snap ring, the regular thrust washer then the thrust washer with the tab.
3. Coat the axle, key, and spring with #2 molybdenum disulfide grease or anti-seize compound before installing the pinion (Fig. 111).



Fig 111

MVC-472

# SINGLE SPEED BEVEL GEAR TRANSMISSION

- The wheel pinion is marked with an R and L for right and left. Identify right and left from the operator's position (Fig. 112). On the right side, the R should face outward. The letter L should face outward on the left side. If the wheel pinions are reversed, the wheels will not drive.

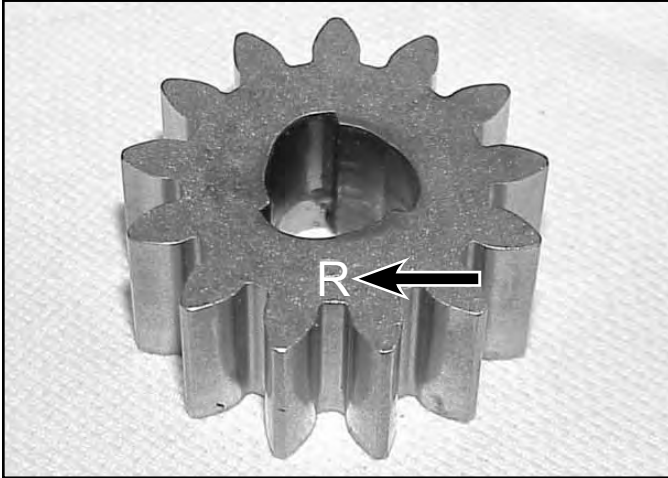

Fig 112

MVC-474

- When installing the rear cover, note the bosses on the back side of the cover. They must go behind the notch in the chassis to secure the cover. The top of the cover is retained with screws (Fig. 113).

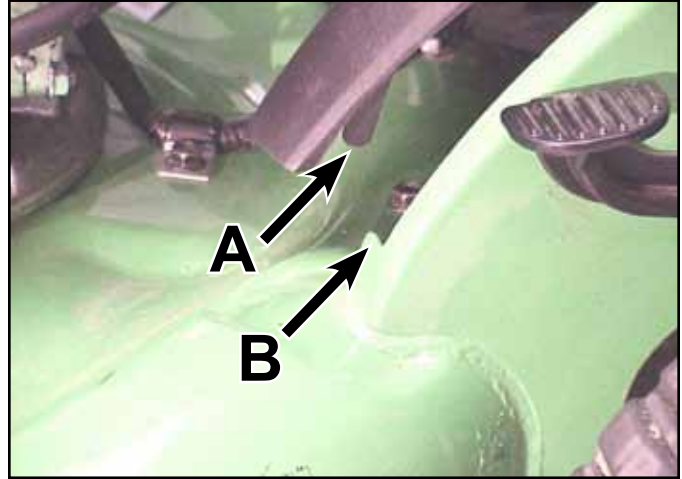

Fig 113

MVC-303

- Make sure the stepped washer is properly seated in the wheel cover. The best way is to assemble the wheel, wheel cover, and wheel bolt, then put them all on the mower together.
- Do not use an impact wrench on the crankshaft belt guide screws. Over-tightening can cause the belt guide to deform and cause the belt not to declutch properly. Tighten firmly with a ratchet.

A. Boss

B. Notch

**Note: Wheel Clutch Service - see Spring Ratchet Key Style Clutch, page 5-8. Control Cable Adjustment - see Handles & Control Cables.**

# THREE SPEED TRANSMISSION

---

Safety Information . . . . .	1
Worm Drive Transmission . . . . .	2
Single Speed Spur/Bevel Gear Transmission . . . . .	3
Single Speed Bevel Gear Transmission . . . . .	4
<b>Three Speed Transmission . . . . .</b>	<b>5</b>
General Transmissions® . . . . .	6
Wheel Pinion Clutch . . . . .	7
Blade Brake Clutch Systems (BBC), Blade Override System (BOS), Blade Clutch Systems (BCS) . . . . .	8
Handles and Control Cables . . . . .	9
Self-Propel Belt Replacement . . . . .	10

# THREE SPEED TRANSMISSION

## GEAR CASE ASSEMBLY

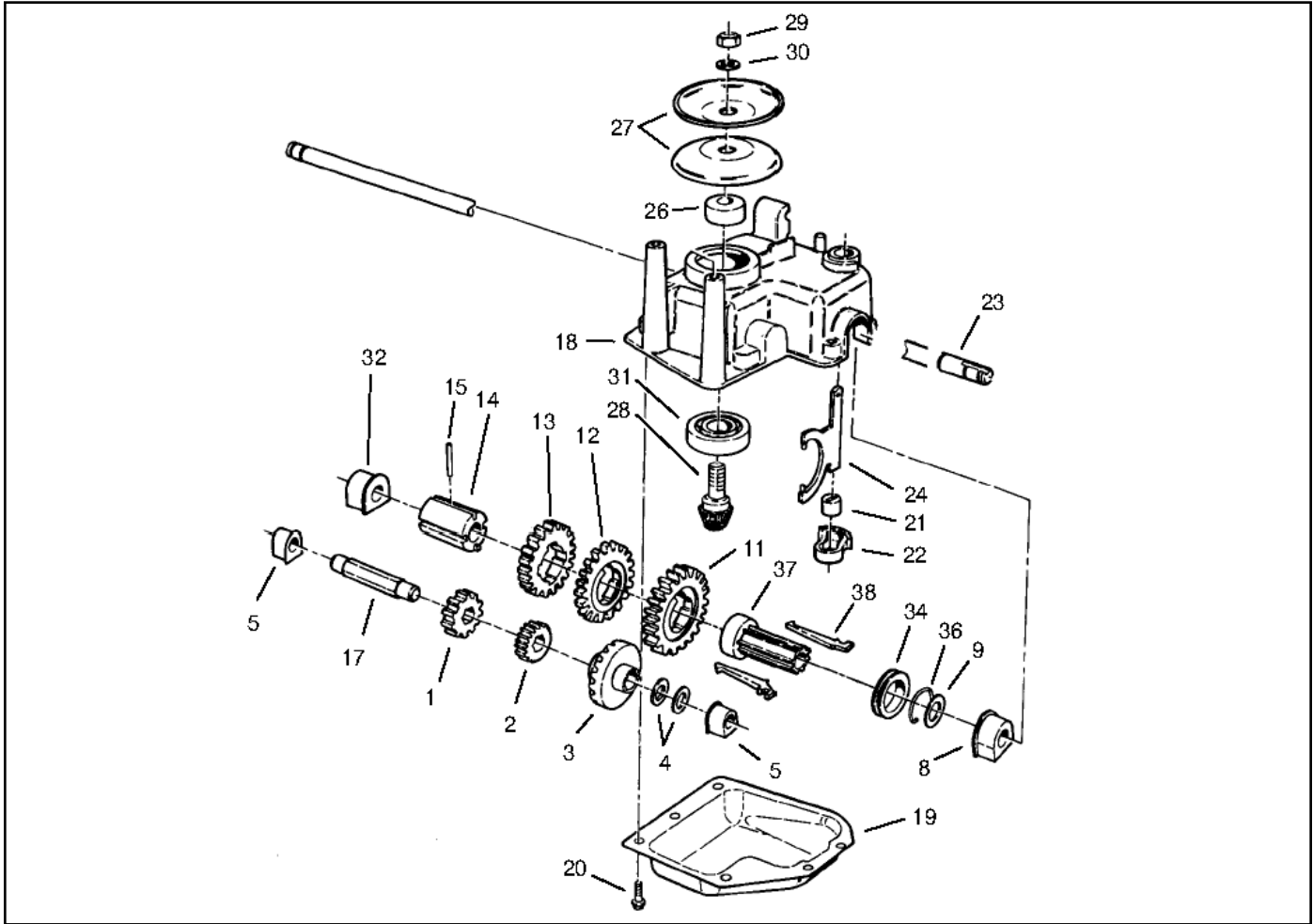

Fig 114

gear case assy

Ref. No.	Qty	Description
1	1	Pinion-25T
2	1	Pinion-20T
3	1	Gear-15t Spur, 37t Bevel
4	2	Washer - Thrust
5	2	Bushing
8	1	Bushing - Output
9	1	Washer
11	1	Gear-49 T
12	1	Gear-44 T
13	1	Gear-39 T
14	1	Sleeve - Gear
15	1	Pin - Spring
17	1	Shaft - Intermediate
18	1	Case - Gear, Upper
19	1	Cover - Case, Gear
20	6	Screw - Tapping

Ref. No.	Qty	Description
21	1	Bushing - Yoke
22	1	Retainer - Fork, Shift
23	1	Shaft - Output
24	1	Yoke - Shift
26	1	Spacer
27	2	Pulley - Half
28	1	Gear - Pinion, Bevel
29	1	Nut - Lock NI
30	1	Washer - Flat
31	1	Bearing - Ball
32	1	Bushing - Output
34	1	Collar - Shift
36	1	Clip - Spring
37	1	Sleeve - Key, Shift
38	2	Key - Shift



# THREE SPEED TRANSMISSION

## OPERATION

### *Input System:*

Power is transferred from the engine to the transmission by a belt. The self-propel pulley at the engine is keyed to the crankshaft. The pulley on top of the transmission is supported by a ball bearing and drives a pinion gear inside the transmission. Tensioning of the belt is accomplished by pivoting the transmission. When the operator squeezes the control bar toward the handle, a control cable tilts the transmission backward and tensions the belt. When the control bar is released, gravity pivots the transmission forward to loosen the belt.

Belt guides at the engine pulley and atop the transmission ensure disengagement by forcing the belt to loop around the engine pulley (Fig. 115).

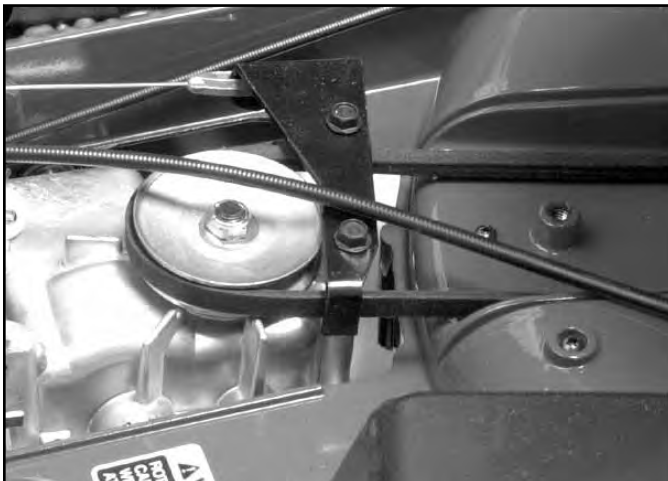

Fig 115

3428-0196

### *Speed Reduction System:*

Speed reduction is accomplished by two sets of gears – one set on the intermediate shaft and the other set on the output shaft. The gears on the intermediate shaft are powdered metal and ride on a hexagonal shaft supported on each end by oil impregnated bushings. These gears are driven by the pinion at the bottom of the input shaft. The driven bevel gear turns the shaft so that all three gears on the intermediate shaft have the same rotational velocity (Fig. 116).

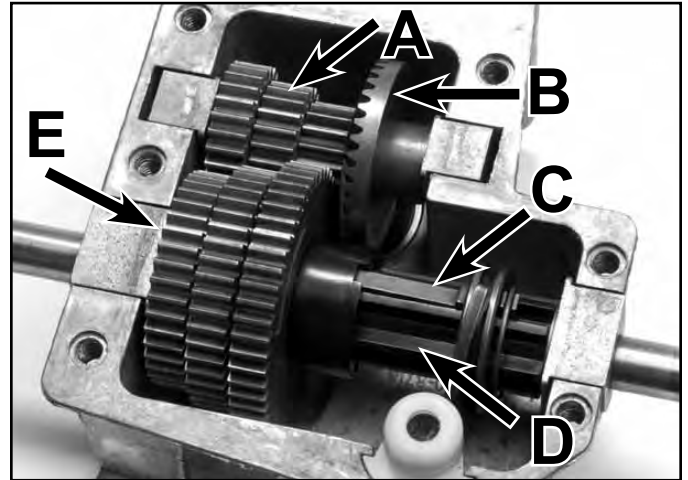

Fig 116

3428-0058

- |                               |                |
|-------------------------------|----------------|
| A. Intermediate shaft & gears | C. Shift key   |
| B. Bevel gear                 | D. Gear sleeve |
| E. Output shaft & gears       |                |

# THREE SPEED TRANSMISSION

There are also three gears on the output shaft. These three gears rotate freely on the gear sleeve. The gear sleeve is coupled to the output shaft with a roll pin so the gear sleeve always rotates with the output shaft. The gear selection system determines which one of these three gears will be coupled with the gear sleeve and the output shaft. This determines the final drive ratio.

## **Gear Selection System:**

Gear selection is determined by moving sliding shift keys in a sleeve that is fixed to the output shaft. These keys engage one of the three gears that rotate on the gear sleeve. Once the key engages one of the gears, that gear will rotate the output shaft. Table 1 shows approximate speeds in gears for two different engine speeds.

Table 1

Gear	Ground Speed @ 3000 RPM	Ground Speed @ 2000 RPM
1	1.8 mph (2.9km/h)	1.2 mph (1.9km/h)
2	2.7 mph (4.4km/h)	1.8 mph (2.9km/h)
3	3.8 mph (6.1km/h)	2.5 mph (4.3km/h)

The shift keys are retained on one end by the shift collar. Movement of the shift fork positions the shift collar and shift key. The shift fork is supported, both top and bottom, by nylon bushings for smooth operation and long wear (Fig. 117).

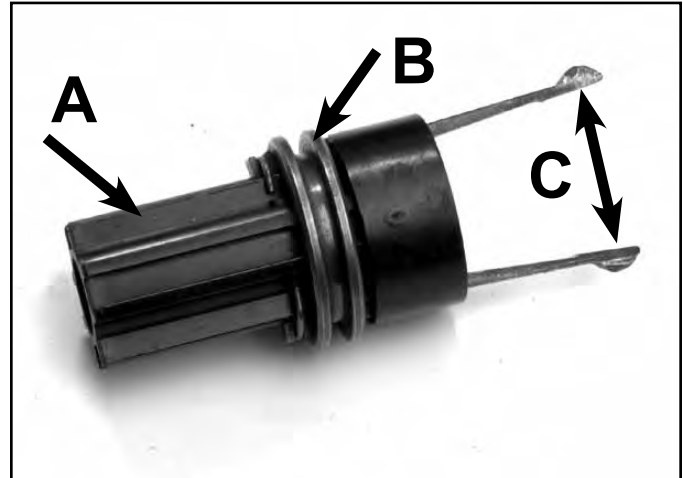

Fig 117

3428-0065

- A. Gear Sleeve
- B. Shift Collar
- C. Keys

The operator controls movement of the shift fork by means of the gear selection control and cable.

**Note: There are no shift detents in or on the transmission on 1988 and newer mowers.**

# THREE SPEED TRANSMISSION

## Removal - Toro Vacu Power/Lawn-Boy Medallion Models

Complete transmission removal on the Toro Vacu Power/Lawn-Boy Medallion mower is quite easy and is recommended for most self-propel system repairs.

1. Remove the spark plug lead from the engine to prevent accidental starting. Drain the fuel and oil.
2. Place the ground speed selector in neutral. This will make it easier to remove the speed selection cable later.
3. Remove the two flanged head self-tapping screws securing the screen panel to the housing and remove the panel (Fig. 118).

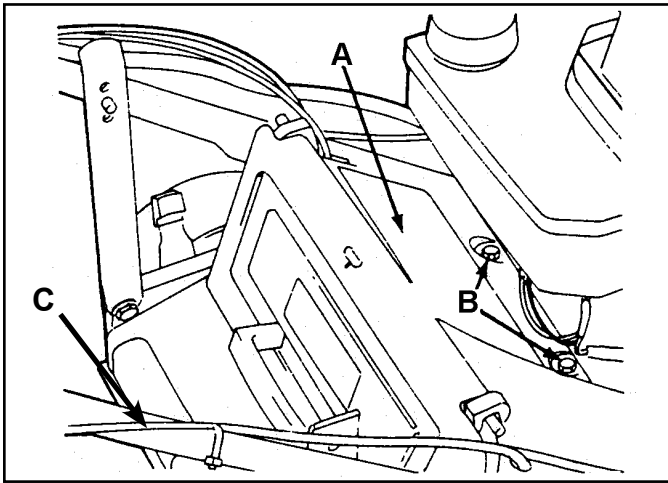

Fig 118

fig 94

- A. Screen panel  
B. Screws  
C. Transmission access cover

4. Remove the black plastic transmission cover from the top rear of the housing.
5. Remove the two flanged head self-tapping screws securing the belt cover to the top of the transmission. Pull the cable from belt guide and remove the belt guide.
6. Remove the transmission access cover from the rear of the housing by pressing from underneath.
7. Loosen the gear selection control cable clamp screw until the cable comes free. Do not attempt to remove the gear selection cable from the control arm at this time.
8. Turn the mower onto its right side and remove the four flanged head self-tapping screws securing the end caps to the housing (Fig. 119).

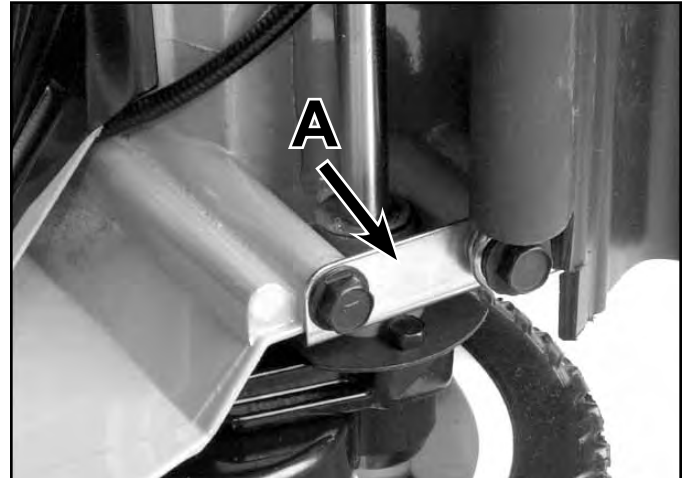

Fig 119

3428-0121

- A. End cap

9. Slowly pull the transmission from the housing being very careful not to damage the gear selection cable. Once clear of the housing, rotate the assembly until the cable can be safely removed.

# THREE SPEED TRANSMISSION

## Removal - Recycler/Rear Bagger Chassis

To remove the transmission from the chassis, raise the rear and support it with blocks.

1. Remove both rear wheels and wheel covers.
2. Remove the rocking key clutches (see "Wheel Pinion Clutch" on page 5-3).
3. Slide the pivot arm and spring arm off the axles.
4. Remove the belt cover. Loosen the belt guide and slip the belt off the pulley. Disconnect shift and clutch cables.
5. Slide the transmission to the right to slip the short end of the axle out of the chassis.

## Alternate Method

1. Pivot both spring arms until they point straight.
2. Remove belt cover and belt.
3. Disconnect shift and clutch cables.
4. Remove 4 self-tapping screws securing end caps to housing (Fig. 120).



Fig 120

3428-0121

## Disassembly

Inspection of this transmission can be accomplished without removing the pivot arm assembly from the output shaft. Only if components on the output shaft require replacement will pivot arm removal be necessary.

1. Remove the six flanged head self-tapping screws securing the transmission cover to the transmission case. Remove the cover (Fig. 121).

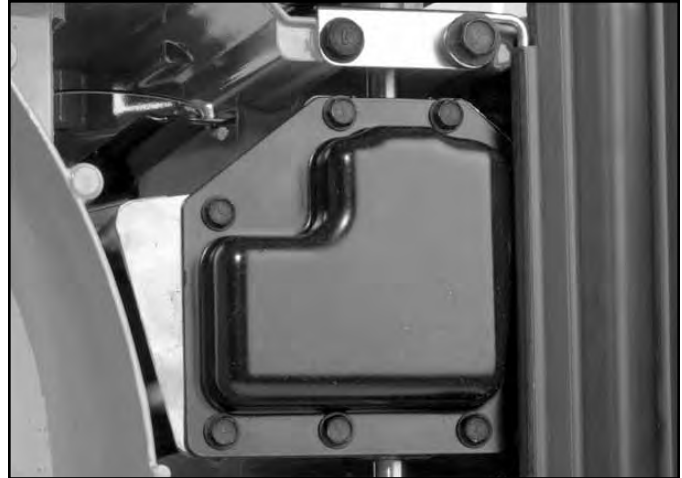

Fig 121

3428-0120

2. Before disassembling further, check for proper operation of the input system, the gear reduction system and gear selection system. For more information on this, refer to "OPERATION" on page 5-3.

# THREE SPEED TRANSMISSION

3. Removal of the input shaft and pulley assembly can be difficult because the input pinion has a tendency to turn as the pulley nut is loosened. This situation can be addressed by using an impact wrench or by removing the 20 (B) and 25 (A) tooth gears (Fig. 122) from the intermediate shaft and then putting the intermediate shaft assembly back onto the transmission. The hexagonal intermediate shaft can then be held with a 7/16" end wrench while the pulley nut is loosened.

**Note:** A cut-away transmission cover can be fabricated to hold the intermediate shaft in place to facilitate pulley nut removal.

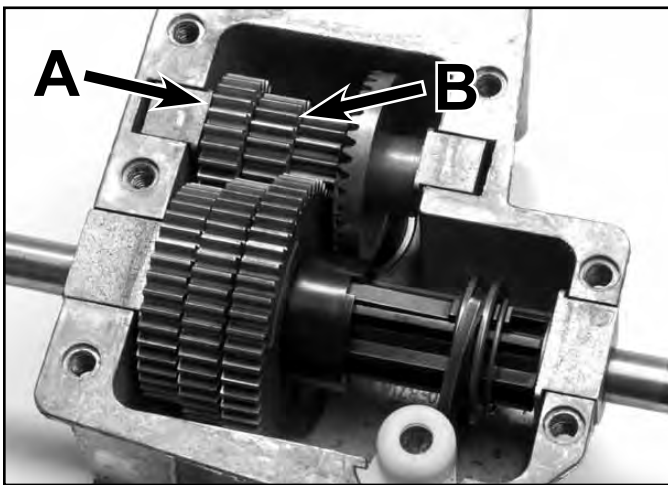

Fig 122

3428-0058

A. 25-tooth gear

B. 20-tooth gear

4. Remove the intermediate shaft from the transmission and clean. Inspect all gears for wear, cracks, and/or broken teeth. Inspect the bushings for excessive wear. Replace any parts necessary. Be careful not to lose the two spacers that fit between the bevel gear and the bushing.

5. Remove the cotter pin from the top of the shift fork and remove the shift lever.
6. Carefully pull the output shaft from the transmission case, clean, and inspect all components for wear or damage. Check the input shaft ball bearing for roughness or excessive drag and replace any parts necessary. If ball bearing replacement is required, press the ball bearing out using an arbor press.
7. If service of any of the output shaft gears, or the gear selection system, is required, remove the left pivot arm as described under "Rear Height-of-Cut and Wheel Pinion Clutch – Disassembly" on page 5-4 and 5-5.

**Note:** It is possible to replace the shift keys and spring clip without removing the pivot arm if the roll pin securing the gear sleeve to the output shaft is first driven out. However, it is not recommended since inspection of the inside of the output gears is not possible.

8. Pull the output shaft bushing, the spacer, the shift collar, the shift keys and spring clip, and the shift key sleeve from the output shaft.
9. Remove the three output shaft gears from the output shaft.
10. Drive out the roll pin securing the gear sleeve to the output shaft. Remove the gear sleeve and remaining output shaft bushing. Inspect all parts for wear and damage and replace if necessary.

# THREE SPEED TRANSMISSION

## Transmission - Assembly

The transmission uses 6 oz. (177cc) No. 2 lithium-based grease as a lubricant. When assembling, be sure to coat all moving components with grease to ensure proper lubrication.

## Output Shaft Assembly

1. Slide the output bushing onto the output shaft, flanged side last. Assemble from the end of the shaft closest to the hole for the roll pin.
2. Slide the gear sleeve onto the output shaft, tabs last and secure with a new roll pin.
3. Apply a light coat of lithium-based grease on the output shaft under the output bushing, on the gear sleeve, and on the three output shaft gears. Slide the three output shaft gears onto the gear sleeve, notched sides last.
4. Slide the nylon shift key sleeve onto the output shaft, large end first. Make sure that it engages the tabs on the gear sleeve (Fig. 123).

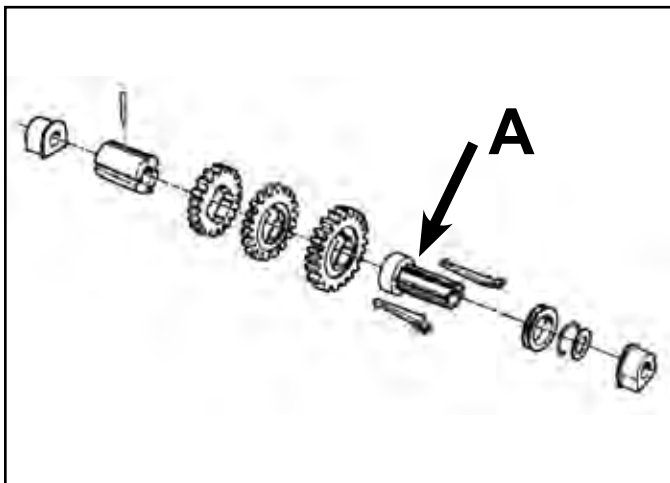

Fig 123

492-4733 fig. 4-1

A. Shift key sleeve

5. Coat the shift key sleeve with grease and prepare the shift keys, shift collar, and spring clip for assembly as shown in Figure 124.

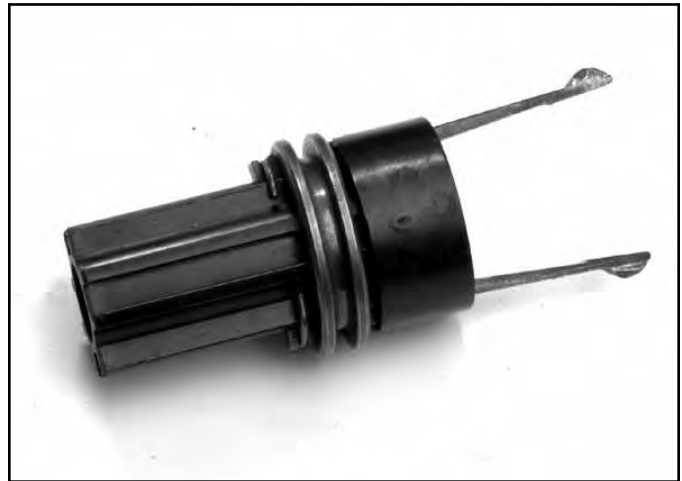

Fig 124

3428-0065

6. Slide the shift key assembly into the shift key sleeve until the shift collar bottoms out.
7. Complete the output shaft assembly by sliding a spacer washer and the other output bushing, flanged side first, onto the output shaft. Don't forget to coat these components with a light coat of grease (Fig. 125).



Fig 125

3428-0066

8. If the left pivot arm was removed for servicing, reassemble now as described under "Rear Height-of-Cut and Wheel Pinion Clutch – Assembly" on page 7-5.

# THREE SPEED TRANSMISSION

## Input Shaft Assembly

1. If the input bearing was removed, press a new one into the gear case using an arbor press. Press only on the outer race or bearing damage may result.
2. Slide the input shaft and pinion through the ball bearing and assemble the spacer and two pulley halves as shown in Figure 126. Install a flat washer and a nylon locknut finger tight.

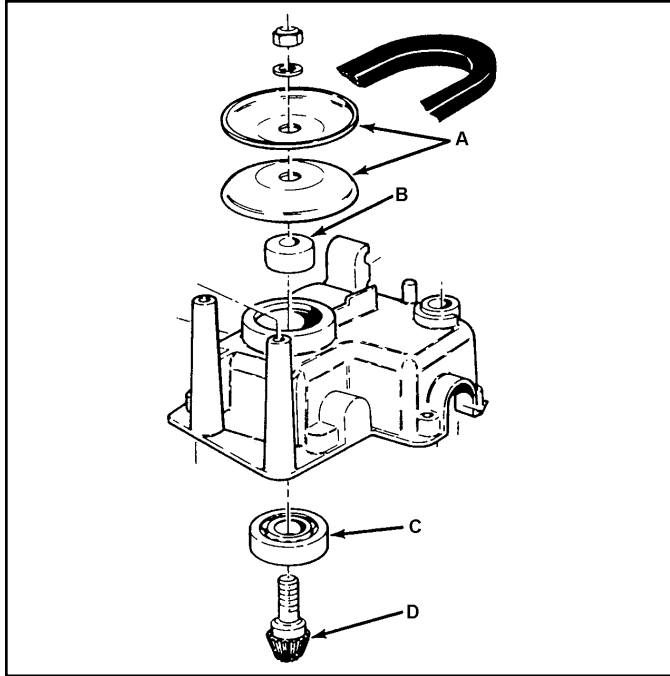

Fig 126

Fig. 100

- |           |                 |
|-----------|-----------------|
| A. Pulley | C. Ball bearing |
| B. Spacer | D. Pinion       |

3. The input pulley nut can be tightened after complete transmission assembly, or at this point using the process in step 3, under Disassembly, page 4-7.
4. Slip the shift fork into the slot on the shift collar and place the shift fork and output shaft assembly into the transmission.

**Note:** The long end of the shift fork shaft should go through the hole in the gear case. Make sure that the output bushings are trapped in the proper locations. Note that the larger output bushing holes on the longer end of the shaft and the shorter output bushing goes on the shorter end of the shaft.

5. Slide the yoke bushing onto the lower end of the shift fork, then secure the shift fork with the white nylon shift fork retainer (Fig. 127).

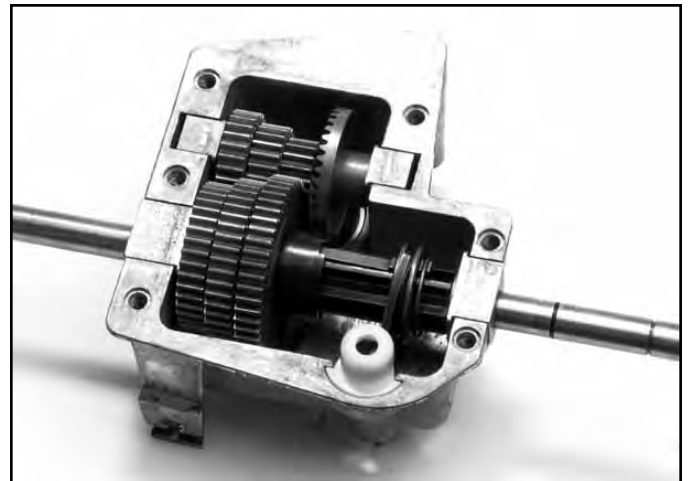

Fig 127

3428-0059

- |                       |                        |
|-----------------------|------------------------|
| A. Intermediate shaft | C. Shift fork retainer |
| B. Flange             |                        |

# THREE SPEED TRANSMISSION

## Intermediate Shaft Assembly

**Note:** Before assembling, coat the intermediate shaft with No. 2 lithium-based grease. Apply a light bead of lithium-based grease to flange.

1. Slip an intermediate shaft bushing onto the left end of the intermediate shaft, flanged end first (Fig. 128).

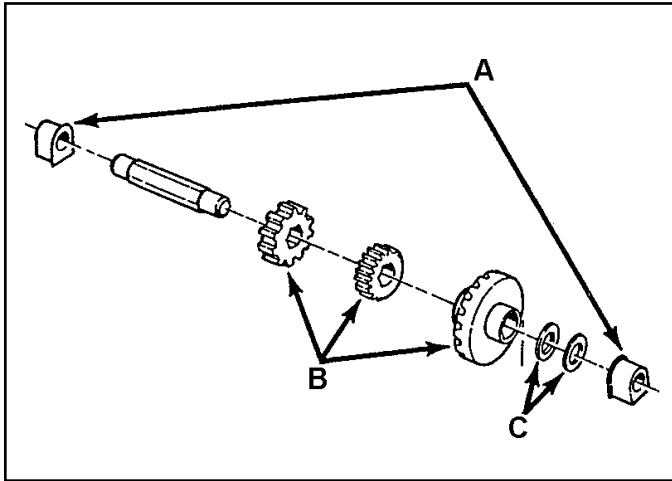

Fig 128

fig. 102

A. Bushings  
B. Gears

C. Spacers

2. Slide the intermediate shaft gears onto the intermediate shaft in this order:
  - a. 25 tooth gear
  - b. 20 tooth gear
  - c. 15 tooth gear/bevel gear
3. Slide 2 spacer washers onto the intermediate shaft next to the bevel gear and follow with an intermediate shaft bushing, flanged side first.
4. Drop the intermediate shaft into the gear case, making sure that all gears engage properly.
5. Fill the gear case with 6 oz. (177cc) of No. 2 lithium-based grease, then install the cover with the six flanged head self-tapping capscrews.
6. Secure the input pulley nut.

## Installation

For assembly, reverse the removal process.

Torque the belt guide fasteners to 130 in-lbs. (15 Nm) (Fig. 129).

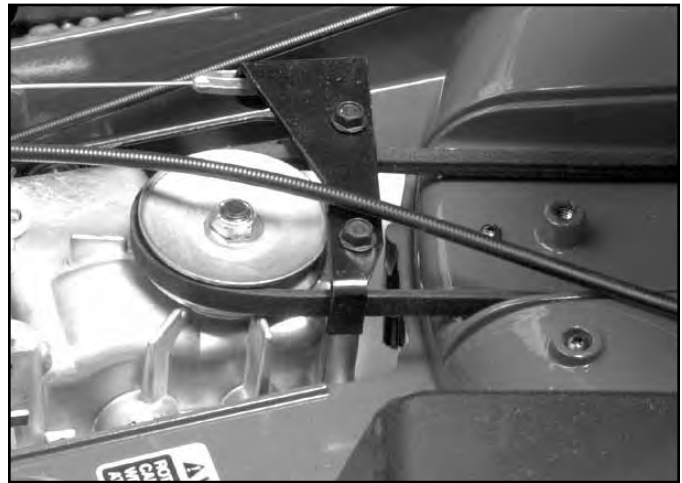

Fig 129

3428-0196



# THREE SPEED TRANSMISSION

## Special Assembly Notes for Toro Vacu Power/Lawn-Boy Medallion

1. Slip the gear selection cable into the shift fork lever through the bottom as shown in Figure 130.



Fig 130

3428-0123

2. Bring the transmission assembly into position underneath the deck, making sure that the end caps are on the outside of the housing. Before securing, install the shift fork control arm onto the shift fork and secure with the cotter pin. Place the transmission and pivot arm assembly into the deck.
3. Loosely install the two front end cap fasteners.

4. Slip the two rear end cap fasteners through the safety shield guide wires then install. Tighten all four end cap fasteners (Fig. 131).

**Note: End cap fastener torque: 225 in-lbs. (26 Nm)**

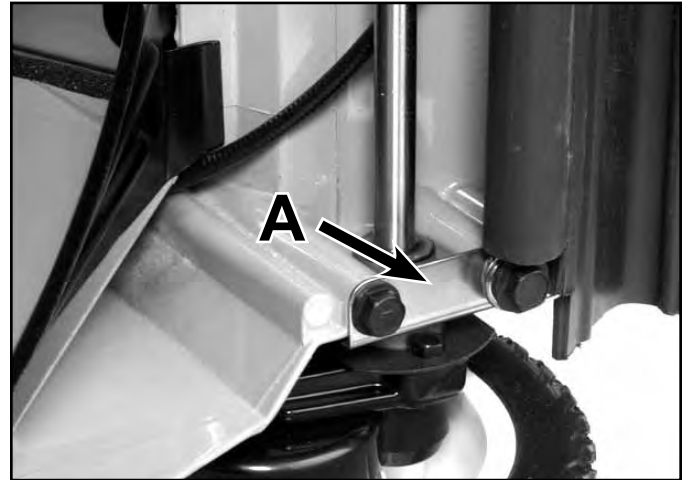

Fig 131

3428-0122

- A. End cap
  5. Slip the traction belt into position on the transmission pulley. Make sure that it does not bind on any of the bosses.
  6. Slip the end of the traction cable into the belt guide bracket from the outside. Install the belt guide bracket onto the top of the transmission, making sure that the traction belt is inside the guide.
- Note: Belt guide fastener torque: 130 in-lbs. (15 Nm)**
7. Slip the black plastic transmission cover into place making sure that the belt falls in the appropriate grooves. Install the upper BBC cover with the two flanged head self-tapping capscrews. Make sure that the top edge is trapped underneath the lip of the housing.

# THREE SPEED TRANSMISSION

## TROUBLESHOOTING TIPS - 3 SPEED TRANSMISSION

### Hard Shifting

A raised boss molded into each gear causes the leading edge of the key to depress before it can enter the next gear (Fig. 132).

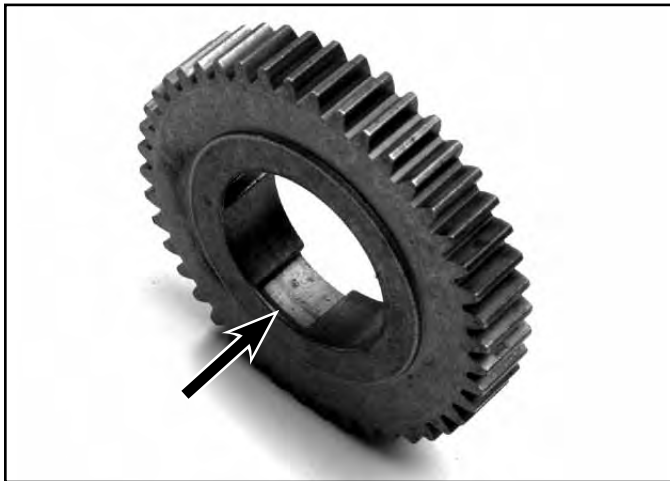

Fig 132

3428-0067

The ring on the shift collar end of the key holds the drive end of the key up. If dried grease or dirt keeps the keys from rocking up and down, the force required to shift gears will increase. Check the cable for free movement where it enters the transmission. These are quick checks and should be made before opening the transmission.

### Slipping Gears

The actual gears are in constant mesh. Unless gear teeth are broken off, they cannot slip. If the wheels lurch forward, then pause and lurch again, along with a loud bang each time, the keys might be slipping.

Look at the key and the notch in the gear that it engages. Excessive wear to the tip of the key or the notch in the gear may be the problem (Fig. 133).

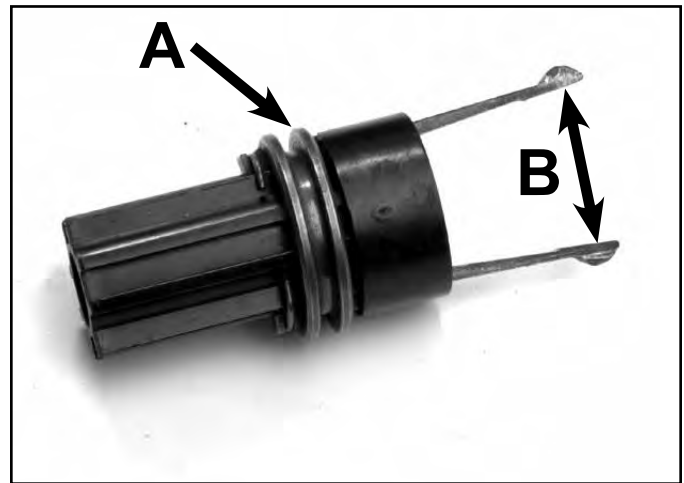

Fig 133

3428-0065

A. Shift collar

B. Shift keys

If the forces push straight on the key, it will drive the axle. However, if due to wear the force tries to depress the key, it can lower enough to disengage from the notch in the gear (Fig. 134).

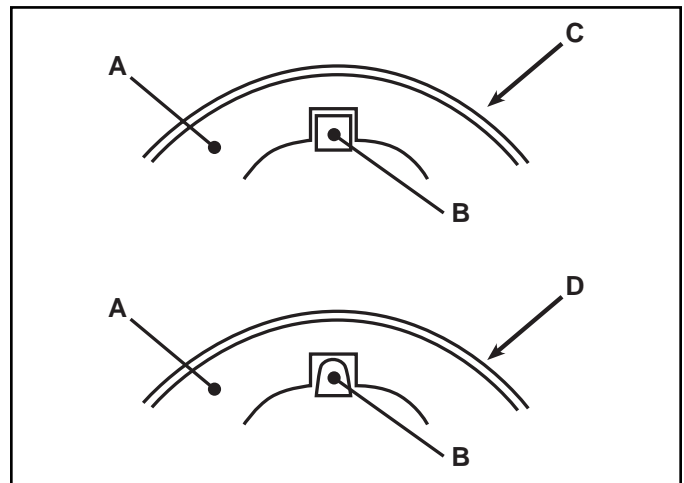

Fig 134

gear and key

A. Gear  
B. Key

C. Good gear and key  
D. Worn gear and key

Safety Information . . . . .	1
Worm Drive Transmission . . . . .	2
Single Speed Spur/Bevel Gear Transmission . . . . .	3
Single Speed Bevel Gear Transmission . . . . .	4
Three Speed Transmission . . . . .	5
<b>General Transmissions® . . . . .</b>	<b>6</b>
Wheel Pinion Clutch . . . . .	7
Blade Brake Clutch Systems (BBC), Blade Override System (BOS), Blade Clutch Systems (BCS) . . . . .	8
Handles and Control Cables . . . . .	9
Self-Propel Belt Replacement . . . . .	10

# GENERAL TRANSMISSIONS®

---

## General Information

General Transmissions internal gears are in constant mesh. Clutching, engaging and disengaging the traction cable will rock the transmission to tighten or loosen the drive belt. When engaged, the traction cable will move the transmission to tighten the belt. When released, the weight of the transmission causes it to rock towards the engine to disengage. These transmissions are not serviceable.

General Transmissions can be found in the following:

- 20" Toro and Lawn-Boy
- 21" Toro and Lawn-Boy
- 22" Toro
- 48cm, 50cm, and 53cm International Toro
- Steel and Cast Aluminum Decks
- Front Wheel Drive
- Rear Wheel Drive

## 22" Steel Deck - Rear Axle and Transmission Assembly

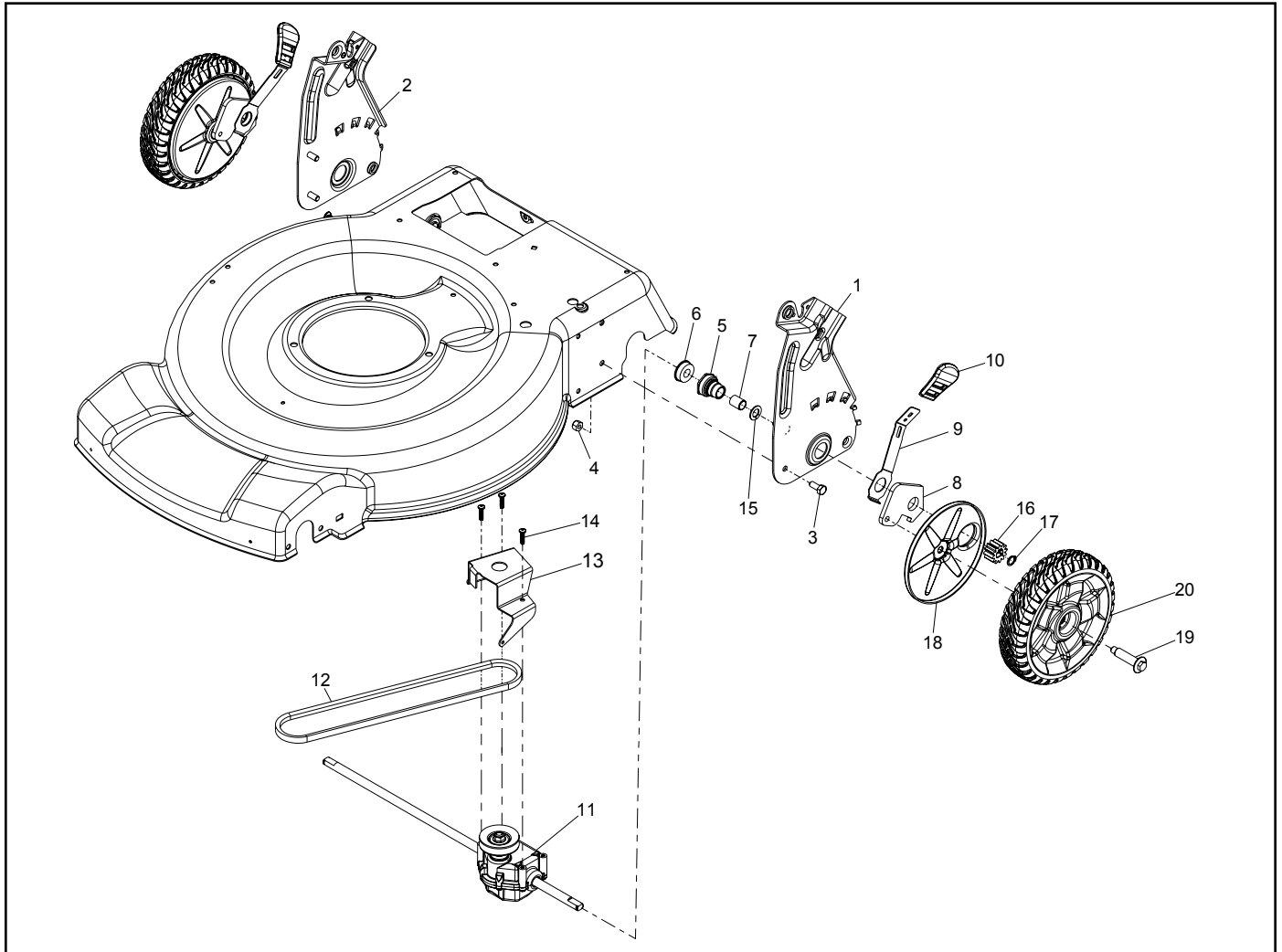

Fig. 135

rear\_drive\_asm

Item	Qty	Description
01	1	Plate-Rear LH
02	1	Plate-Rear RH
03	4	Screw-HH
04	4	Nut-Lock
05	2	Retainer-Bushing, HOC
06	2	Bearing-Ball
07	2	Bushing-Sleeve
08	2	Arm-Pivot Rear
09	2	Arm-Spring
10	2	Knob-HOC
11	1	Transmission Asm
11	1	Transmission

Item	Qty	Description
12	1	Belt-V
13	1	Bracket-Transmission
14	3	Screw-Plastite
15	2	Washer-Thrust
16	2	Gear-Pinion
17	2	Ring-Retaining
18	2	Wheel Cover Asm
19	2	Bolt-Shoulder
20	2	Wheel Gear Asm

# GENERAL TRANSMISSIONS®

## 22" Steel Deck - Rear Axle Belt Replacement

1. Remove (2) belt cover screws (Fig. 136).



Fig. 136

001

2. Move height-of-cut spring arms past the highest setting to gain access to the fasteners on both sides (Fig. 137).



Fig. 137

002a

3. There are a total of (5) rear baffle screws. There are (2) screws, as shown, on each side and (1) screw on the back of the machine under the bag door (Fig. 138).



Fig. 138

002

4. Tip mower on its side, air filter up. DO NOT tip the mower with the air filter side down. Remove the rear baffle and belt cover (Fig. 139).

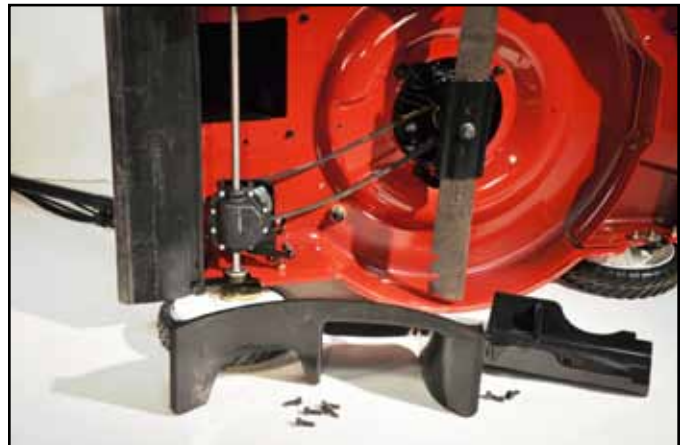

Fig. 139

003a

- Remove blade bolt(s) (A), blade support (B), blade (C), and blade driver (D) (Fig. 140).

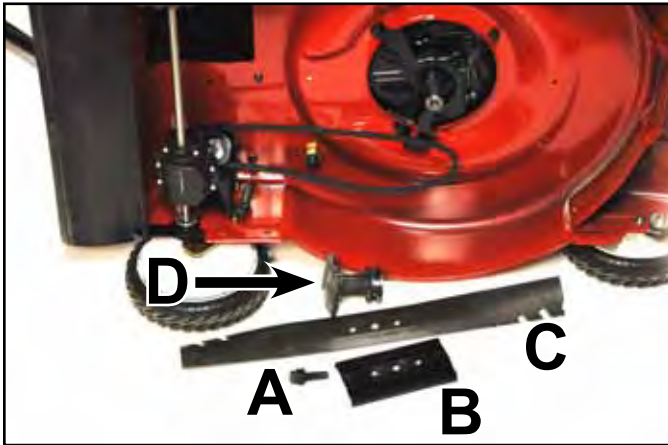

Fig. 140

004

- Release traction cable guide bushing (Fig. 141).

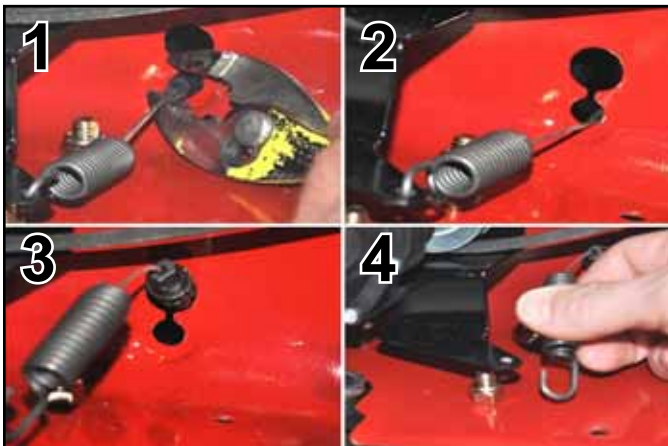

Fig. 141

005

- Move traction cable up to allow the cable guide bushing to pass through the larger upper hole. This will provide enough slack to disconnect the cable from the transmission (Fig. 141).
- Disconnect cable from transmission (Fig. 141).

- Rotate the transmission forward enough to remove the (3) screws (#14) holding the belt guide (#13) to the top of the transmission (#11). Remove belt guide (Fig. 142).

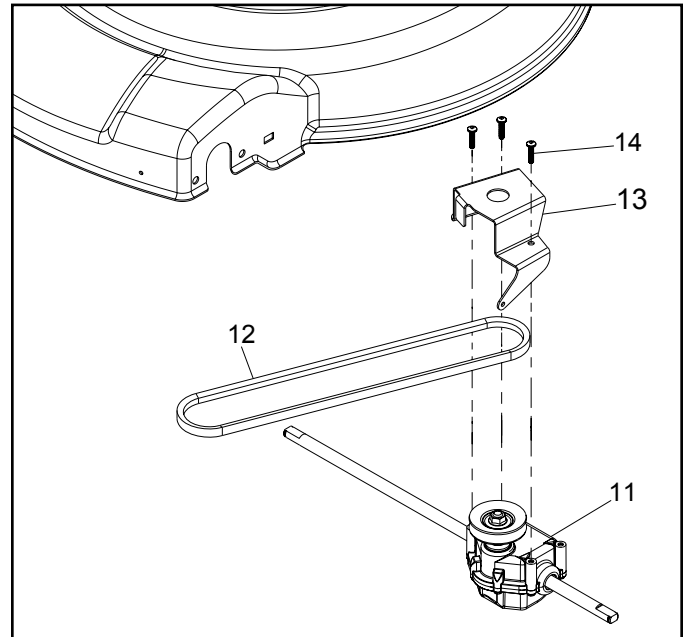

Fig. 142

rear drive-bg

- Remove the old belt and install a new belt. If not replacing the transmission reassemble in reverse order. To replace the transmission see "22" Steel Deck - Rear Axle Transmission Replacement" in this chapter. **See operator's manual for blade bolt torque specification.**

# GENERAL TRANSMISSIONS®

## 22" Steel Deck - Rear Axle Transmission Replacement

1. Remove both shoulder bolts (#19), wheel assemblies (#20), retaining rings (#17), and pinion gears (#16) (Fig. 143).

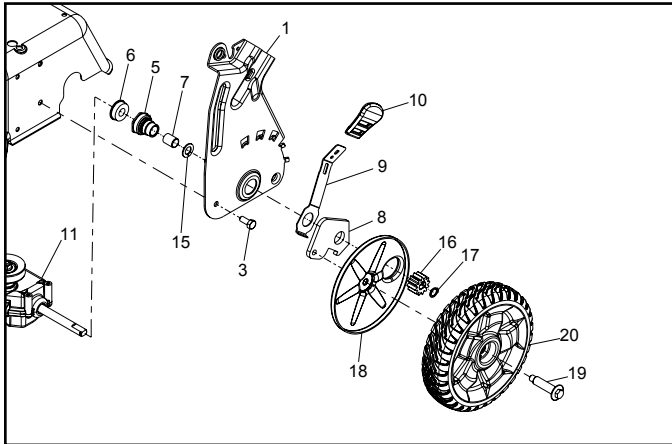

Fig. 143 rear\_drive\_pinion\_a

2. Loosen but don't remove (2) screws (#3) from left side height-of-cut plates (Fig. 144).

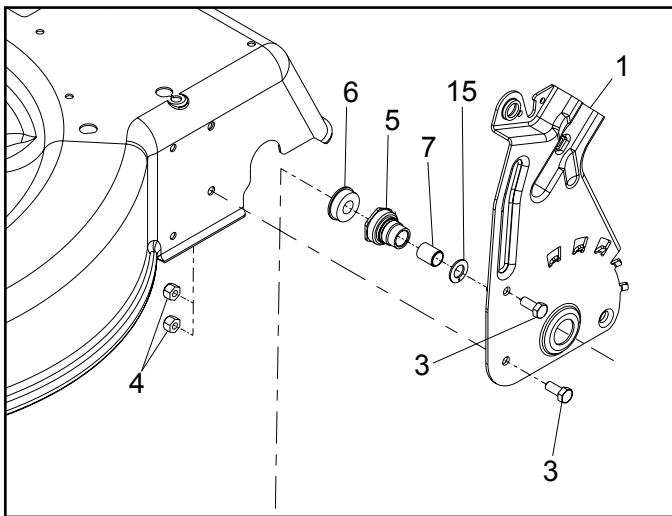

Fig. 144 rear\_drive\_asm\_plate

3. Remove (2) screws (#3) from right side height-of-cut plates.
4. Slide transmission toward the left side of the mower and out of the right hand bearing retainer and pivot arm (Fig. 145).

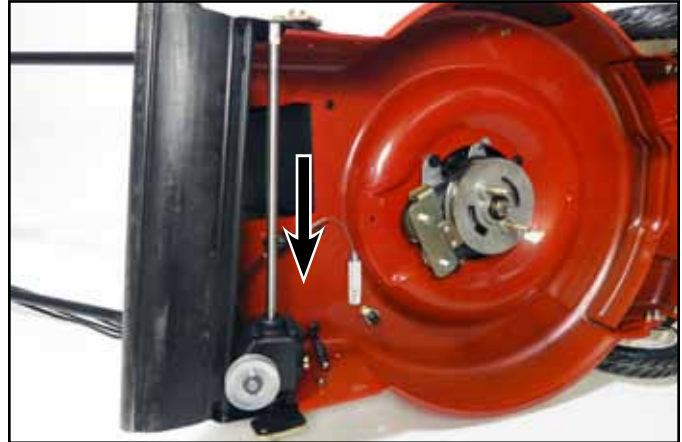

Fig. 145 006a

5. Once the transmission is out of the right side bearing retainer and pivot arm, slide the transmission toward the right side and out of the left hand bearing retainer and pivot arm (Fig. 146).

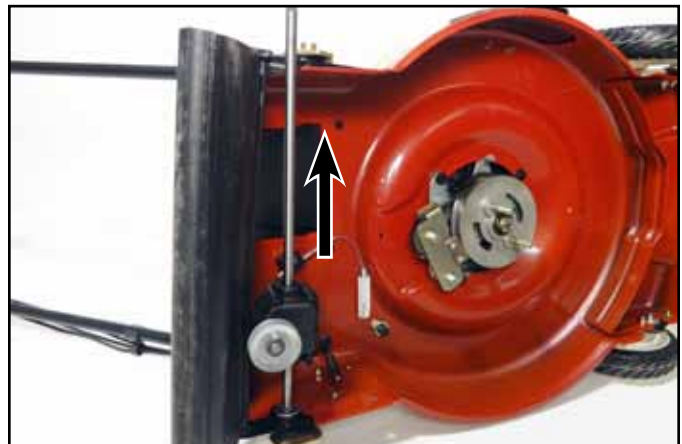

Fig. 146 PICT-007

6. Replace transmission.
7. Follow the procedure in reverse order to reassemble. **See operator's manual for blade bolt torque specification.**



## 22" Steel Deck - Front Axle and Transmission Assembly

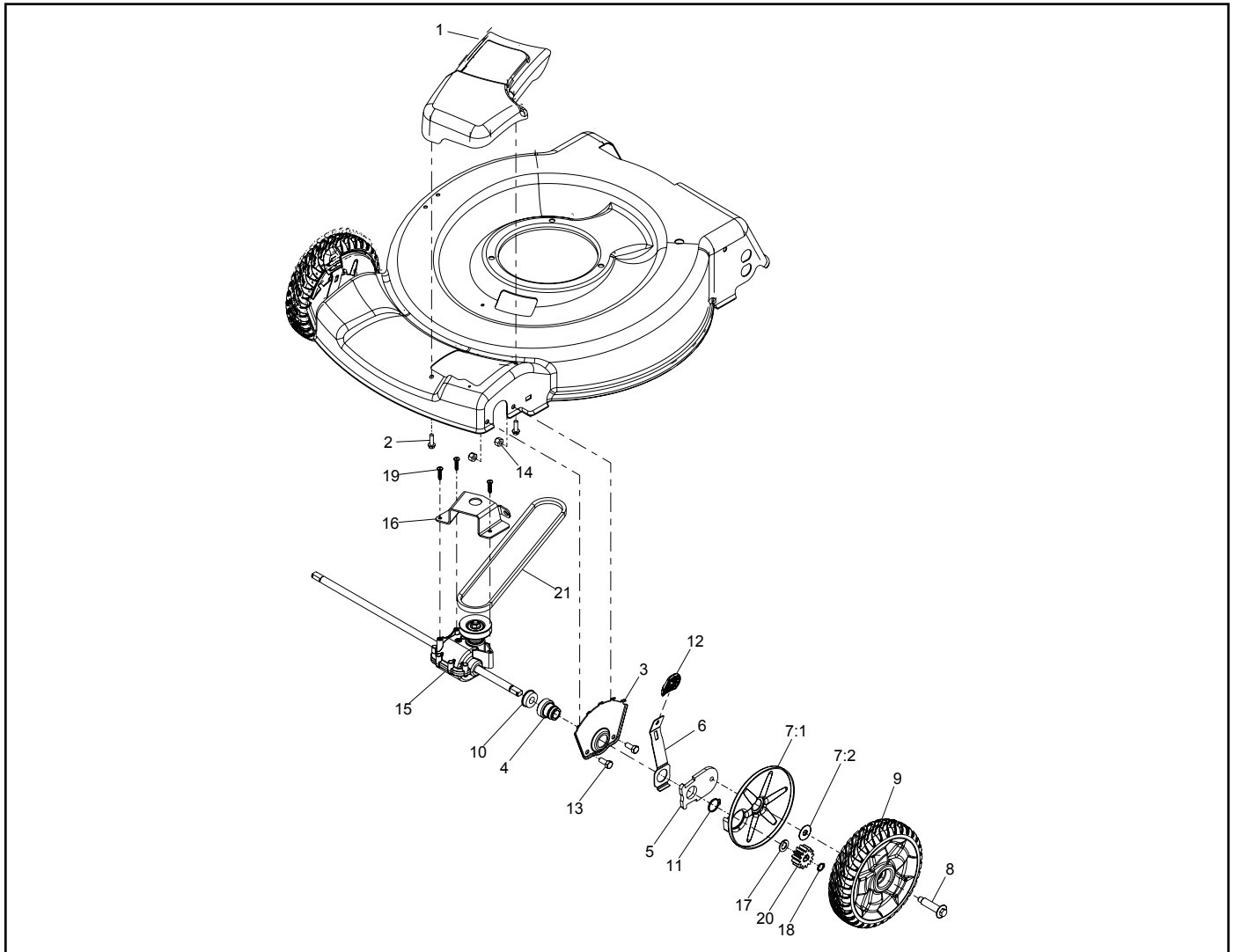

Fig. 147

front\_drive\_asm

Item	Qty	Description
01	1	Cover-Belt
02	2	Screw
03	2	Plate-HOC
04	2	Retainer-bearing, HOC
05	2	Arm-Pivot, Front
06	2	Arm-Spring
07	2	Wheel Cover Asm
08	2	Bolt-Shoulder
09	2	Wheel Gear Asm
10	2	Bearing-Ball
11	2	Ring-Retaining

Item	Qty	Description
12	2	Knob-Lever, HOC
13	4	Screw-HH
14	4	Nut-Lock
15	1	Transmission
16	1	Bracket-Transmission
17	2	Washer-Thrust
18	2	Ring-Retaining
19	3	Screw-Plastite
20	2	Gear-Pinion
21	1	V-Belt

# GENERAL TRANSMISSIONS®

## 22" Steel Deck - Front Axle Belt Replacement

1. Remove (2) belt cover screws (#2) to expose transmission (Fig. 148).

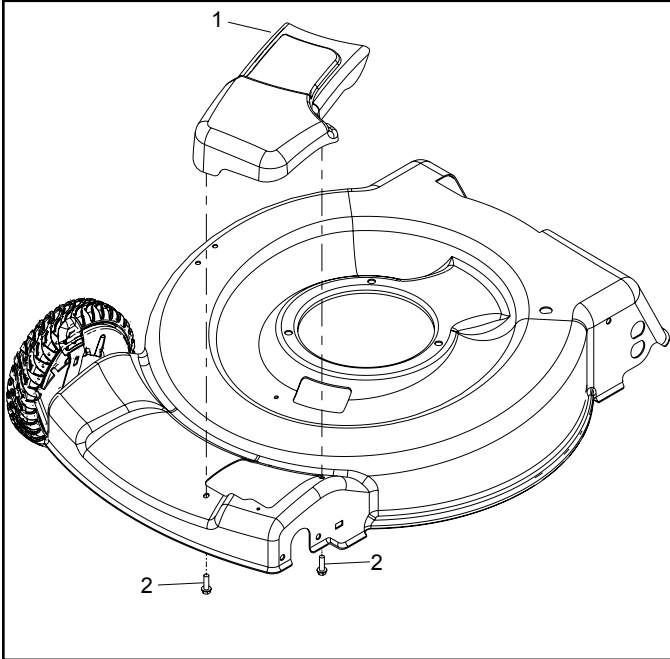

Fig. 148 front\_drive\_asm\_cover

2. Remove the (3) screws (A) holding the transmission belt guide to the top of the transmission and remove transmission belt guide (Fig. 149 and Fig. 150).

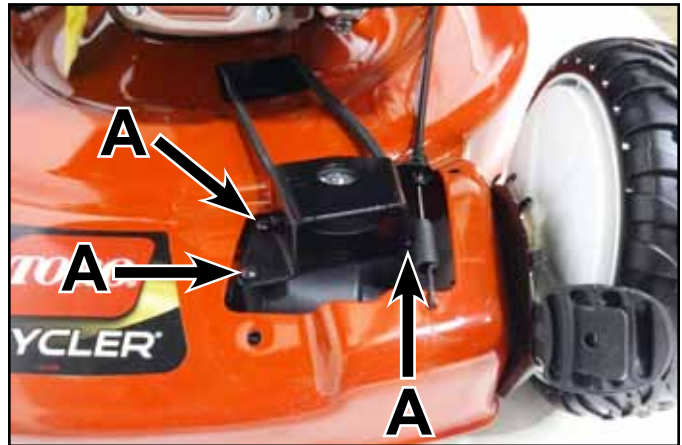

Fig. 149

010a



Fig. 150

011a

- Tip mower on its side, air filter up. DO NOT tip the mower with the air filter side down (Fig. 151).



Fig. 151

008a

- Remove blade bolt (B), blade support (C), blade (D) and blade driver (E) (Fig. 152).

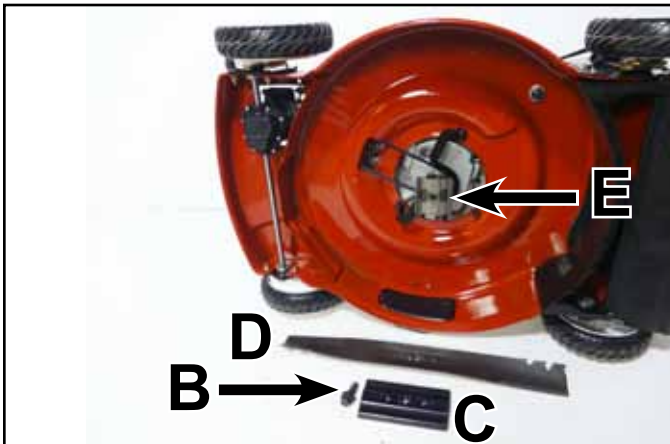

Fig. 152

012

- Remove the old belt and install a new belt. To replace the transmission see "22" Steel Deck - Front Axle Transmission Replacement" in this chapter. If not replacing the transmission, reassemble in reverse order. **See operator's manual for blade bolt torque specification.**

## 22" Steel Deck - Front Axle Transmission Replacement

- Remove both shoulder bolts (#8), wheel assemblies (#9), retaining rings (#18), and pinion gears (#20) (Fig. 153).

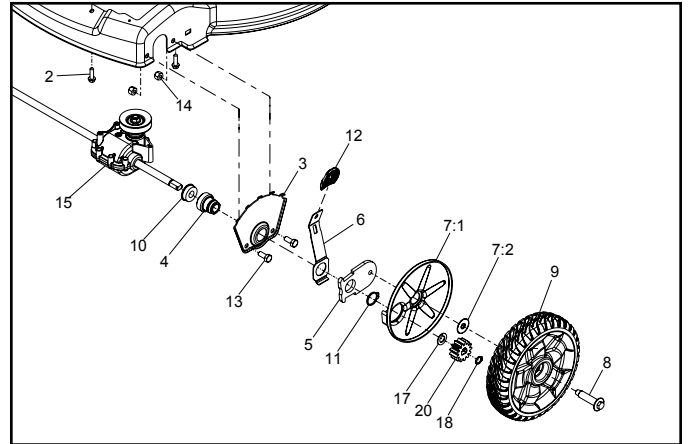

Fig. 153

front\_drive\_pinion

- Remove (2) screws (#13) from each height-of-cut plate (#3) (Fig. 154).

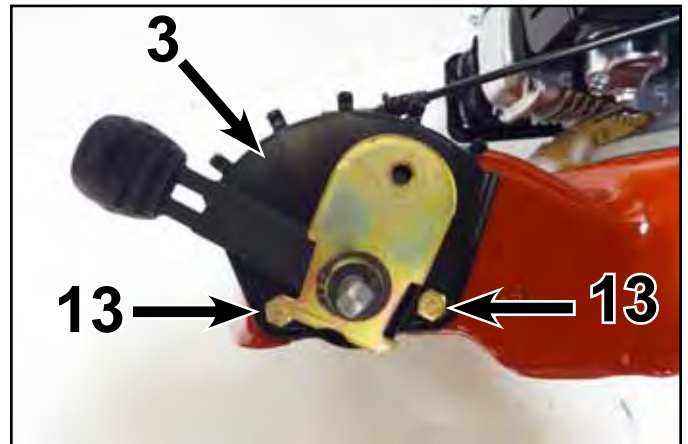

Fig. 154

013a

- Remove height-of-cut plates with transmission.
- Slide pivot arm assemblies (#5) off of the transmission shafts (Fig. 153).
- Replace transmission.
- Follow the procedure in reverse order to reassemble. **See operator's manual for blade bolt torque specification.**

# GENERAL TRANSMISSIONS®

## 21" Steel Deck - Rear Axle and Transmission Assembly

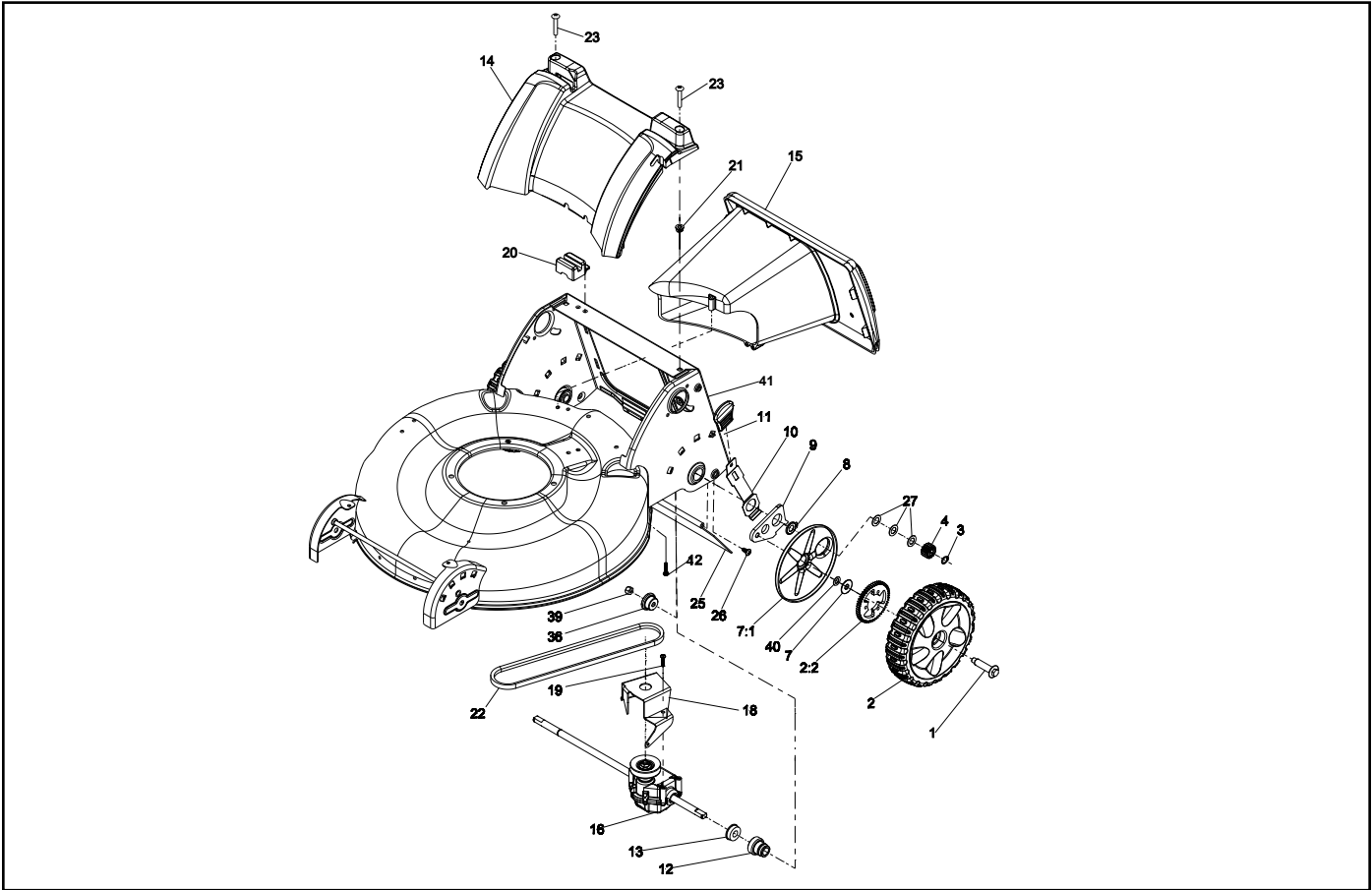

Fig. 155

drive\_asm\_a1

Item	Qty	Description
01	2	Bolt - Shoulder
02	2	Wheel and Gear Asm
03	2	Ring - Retaining
04	2	Gear - Pinion
07	2	Wheel Cover Asm
08	2	Ring - Retaining
09	1	Arm - Rear Pivot, LH
10	2	Arm - Spring, Rear
11	2	Knob - HOC
12	2	Retainer - Bearing, HOC
13	2	Bearing - Ball
14	1	Cover - Rear
15	1	Tunnel
16	1	Transmission
18	1	Bracket - Transmission

Item	Qty	Description
19	3	Screw - Plastite
20	1	Module - Switch
21	2	Nut - Clip
22	1	V-Belt
23	2	Screw - PTH
25	1	Shield - Trailing
26	2	Screw - PTH
27	3	Washer - Plain
28	1	Arm - Rear Pivot, RH
36	2	Bushing - Mount, HOC
39	2	Nut - Lock
40	2	Washer (Bolt, Wheel)
41	1	Deck
42	8	Screw - Plastite

## 21" Steel Deck - Rear Axle Belt Replacement

1. Remove (2) screws from rear cover to access belt cover and tunnel screws (Fig. 156).



Fig. 156

015a

2. Remove (3) belt cover screws and belt cover (Fig. 157).

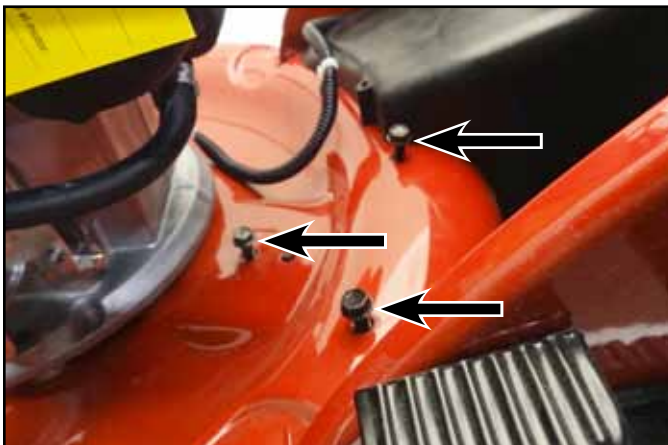

Fig. 157

016a

3. Tip mower on its side air filter up. DO NOT tip the mower with the air filter side down.

4. Remove (3) screws from tunnel and remove tunnel.

**Note:** Although it is not necessary to remove this part it provides the best access to remove the transmission belt guide screws (Fig. 158).

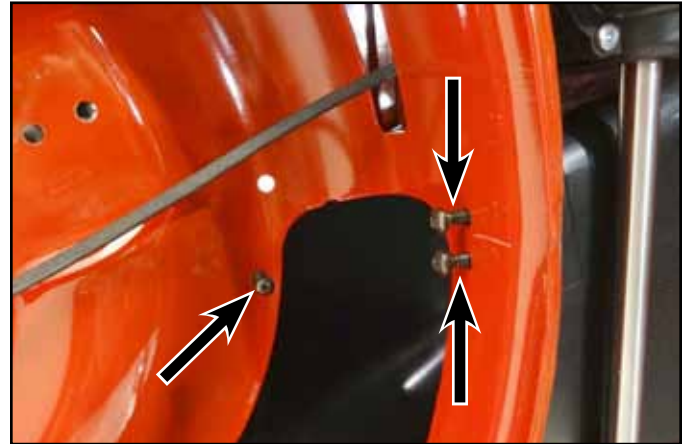

Fig. 158

017a

5. Remove blade bolt, blade support, blade, blade driver and belt cover.

6. Tip mower back onto its wheels to remove (3) transmission belt guide screws and belt guide by accessing screws through rear deck opening (Fig. 159).



Fig. 159

019a

7. Remove the old belt and install a new belt. If not replacing the transmission reassemble in reverse order. To replace the transmission see "21" Steel Deck - Rear Axle Transmission Replacement" in this chapter. **See operator's manual for blade bolt torque specification.**

# GENERAL TRANSMISSIONS®

## 21" Steel Deck - Rear Axle Transmission Replacement

1. Remove (2) screws (#26) from trailing shield (#25) and remove trailing shield (Fig. 160).
2. Remove both wheel assemblies (#2) (Fig. 160).

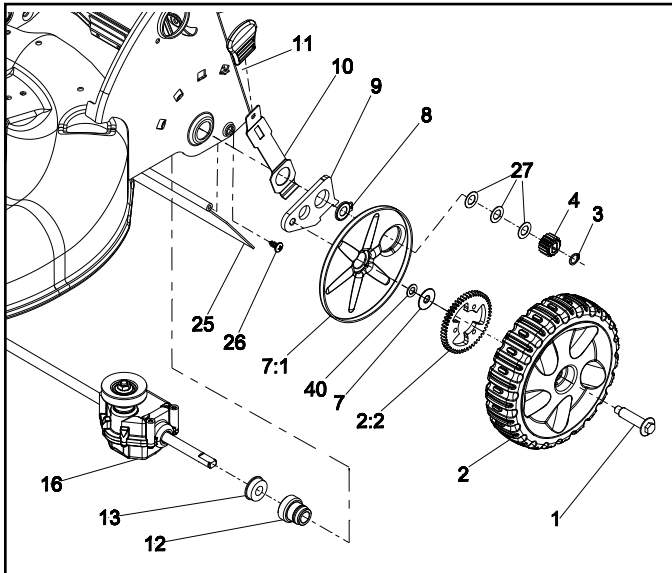

Fig. 160

drive\_pinion

4. Remove retaining rings (#3), pinion gears (#4), bearing retainer retaining rings (#8), pivot arms (#9), and height-of-cut spring arms (#10) (Fig. 160).
5. Slide both bearing retainers (#12) in toward the transmission case (Fig. 160).
6. Slide transmission to the right hand side and out of the left hand bearing retainer frame hole.
7. Slide transmission to the left hand side and out of the right hand bearing retainer frame hole.
8. Replace transmission.
9. Follow the procedure in reverse order to reassemble. **See operator's manual for blade bolt torque specification.**

3. Rotate both height-of-cut spring arms down below deck to relieve tension on the bearing retainer retaining ring (Fig. 161).



Fig. 161

020

## Cast Deck - Rear Axle and Transmission Assembly

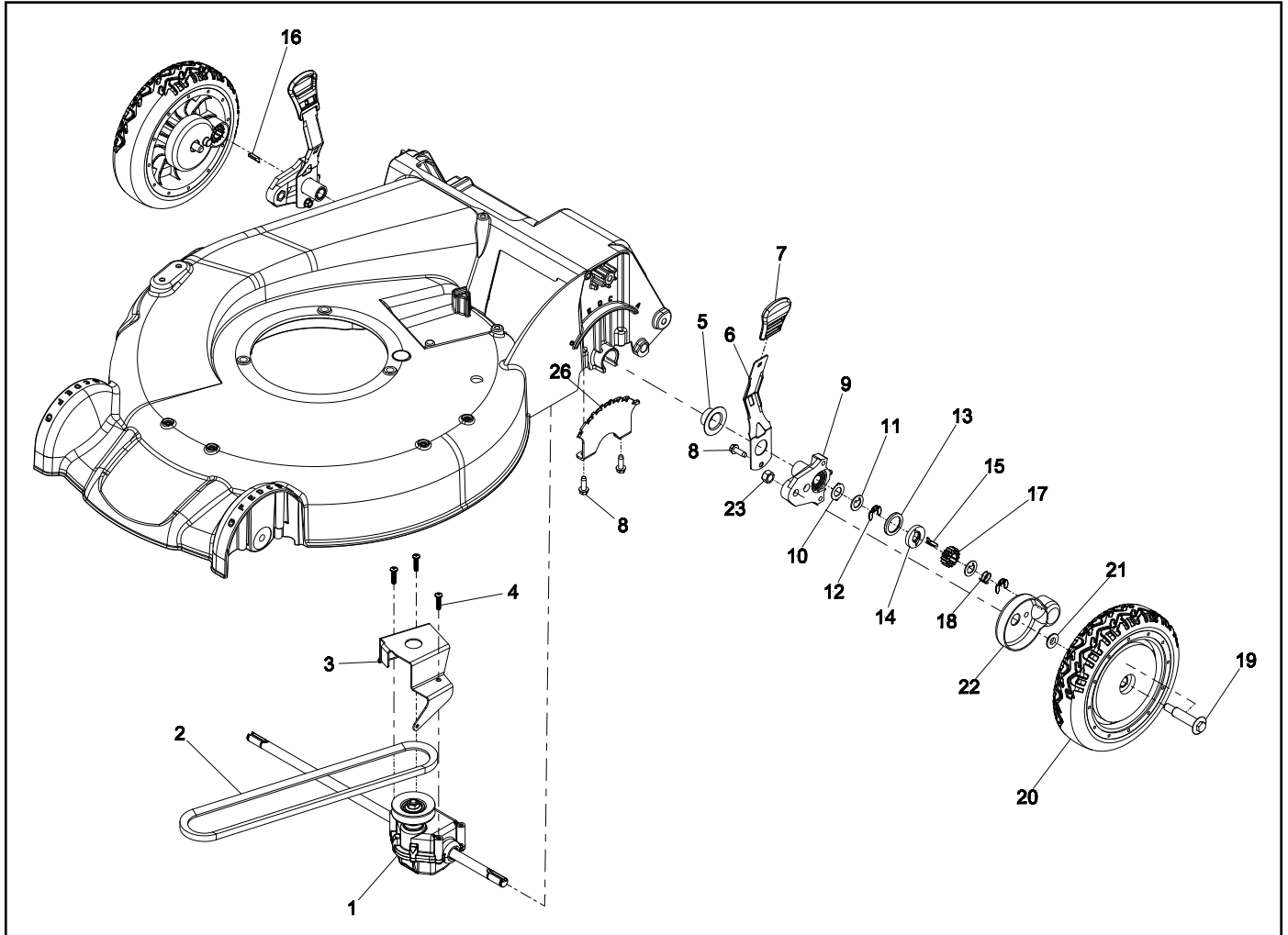

Fig. 162

cast\_deck\_asm\_a

Item	Qty	Description
01	1	Transmission Asm
02	1	V-Belt
03	1	Bracket - Transmission
04	3	Screw - Plastite
05	2	Cap - End
06	2	Arm - Spring
07	2	Knob - HOC
08	6	Screw
09	2	Pivot Arm Asm
10	2	Washer - Arm, Pivot
11	4	Washer - Thrust, Keyed
12	4	Ring - Clip, Locking

Item	Qty	Description
13	2	Ring, Friction
14	2	Washer - Clutch
15	1	Key - Rocking, LH
16	1	Key - Rocking, RH
17	2	Gear - Pinion
18	2	Spring - Compression
19	2	Bolt - Shoulder
20	2	Wheel Gear Asm
21	2	Spacer - Cover, Wheel
22	2	Cover - Wheel
23	2	Nut - Hex
26	2	Plate - HOC

# GENERAL TRANSMISSIONS®

## Cast Deck - Rear Axle Belt Replacement

1. Up near the handle, loosen traction cable anchor nut (#14) and pull traction cable housing (#15) up toward handle, which provides enough slack to remove traction cable from transmission (Fig. 163).

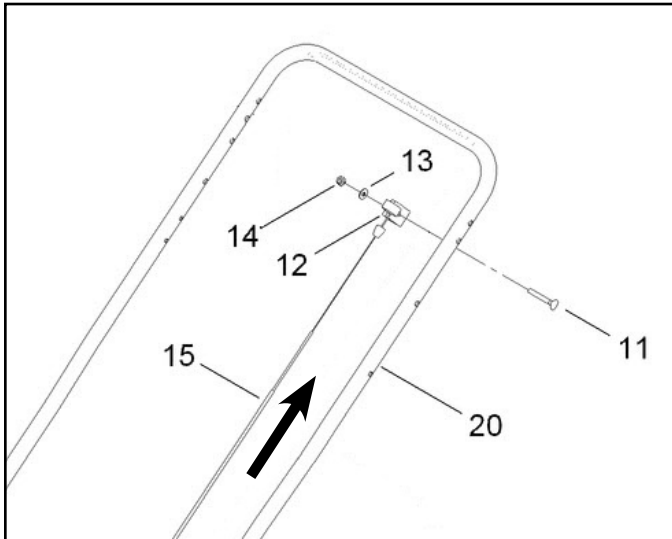

Fig. 163 handle

- |                    |                      |
|--------------------|----------------------|
| 11. Screw          | 14. Nut - Lock       |
| 12. Anchor - Cable | 15. Cable - Traction |
| 13. Washer - Flat  | 20. Handle           |

2. Remove (1) belt cover screw and belt cover from top of deck, which provides access to the transmission belt guide screws (Fig. 164).



Fig. 164 021

3. Disconnect traction cable from transmission (Fig. 165).
4. Remove blade bolt, blade accelerator, blade, and blade driver.
5. Tip mower on its side, air filter up. DO NOT tip the mower with the air filter side down.
6. Remove (3) transmission belt guide screws and belt guide (Fig. 165).



Fig. 165 022a

7. Remove the old belt and install a new belt. If not replacing the transmission, reassemble in reverse order. To replace the transmission see "Cast Deck - Rear Axle Transmission Replacement" in this chapter. **See operator's manual for blade bolt torque specification.**



## Cast Deck - Rear Axle Transmission Replacement

1. Rotate both height-of-cut spring arms forward and down below deck to relieve tension on the locking ring clip (Fig. 166).

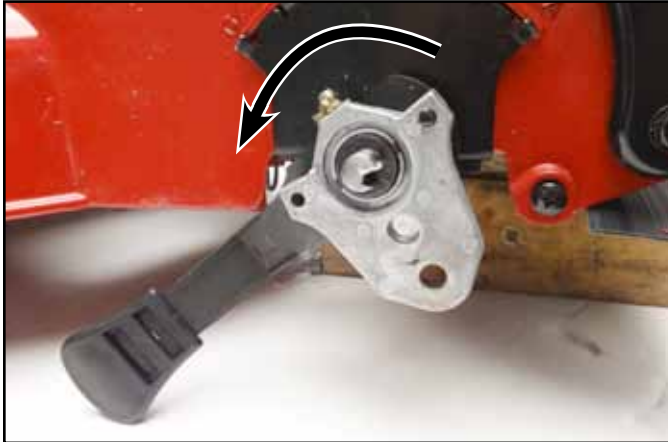

Fig. 166

023a

2. On both sides remove stack up of parts, 1-12, from wheel shoulder bolt to second locking ring clip. See breakdown (Fig. 167).

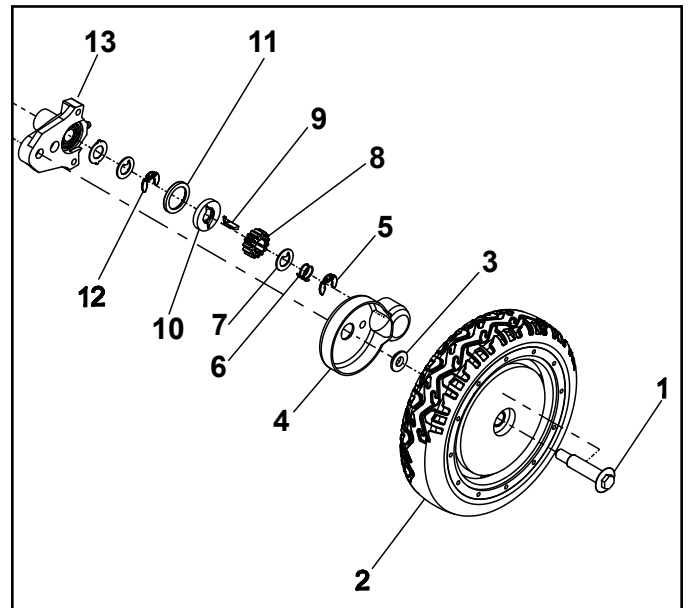

Fig. 167

024

- |                        |                         |
|------------------------|-------------------------|
| 1. Bolt-Shoulder       | 7. Washer-Thrust, Keyed |
| 2. Wheel Gear Asm      | 8. Gear-Pinion          |
| 3. Spacer-Cover, Wheel | 9. Key-Rocking, LH      |
| 4. Cover-Wheel         | 10. Washer-Clutch       |
| 5. Ring-Clip, Locking  | 11. Ring-Friction       |
| 6. Spring-Compression  | 12. Ring-Clip, Locking  |
|                        | 13. Pivot arm assembly  |

3. Slide pivot arm assemblies #13 (Fig. 167) out of deck slots and off transmission shafts.
4. Replace transmission.
5. Follow the procedure in reverse order to reassemble. **See operator's manual for blade bolt torque specification.**

**THIS PAGE INTENTIONALLY LEFT BLANK.**

# WHEEL PINION CLUTCH

Safety Information . . . . .	1
Worm Drive Transmission . . . . .	2
Single Speed Spur/Bevel Gear Transmission . . . . .	3
Single Speed Bevel Gear Transmission . . . . .	4
Three Speed Transmission . . . . .	5
General Transmissions® . . . . .	6
<b>Wheel Pinion Clutch . . . . .</b>	<b>7</b>
Blade Brake Clutch Systems (BBC), Blade Override System (BOS), Blade Clutch Systems (BCS) . . . . .	8
Handles and Control Cables . . . . .	9
Self-Propel Belt Replacement . . . . .	10

# WHEEL PINION CLUTCH

## GEAR CASE AND WHEEL ASSEMBLY, ROCKING KEY STYLE

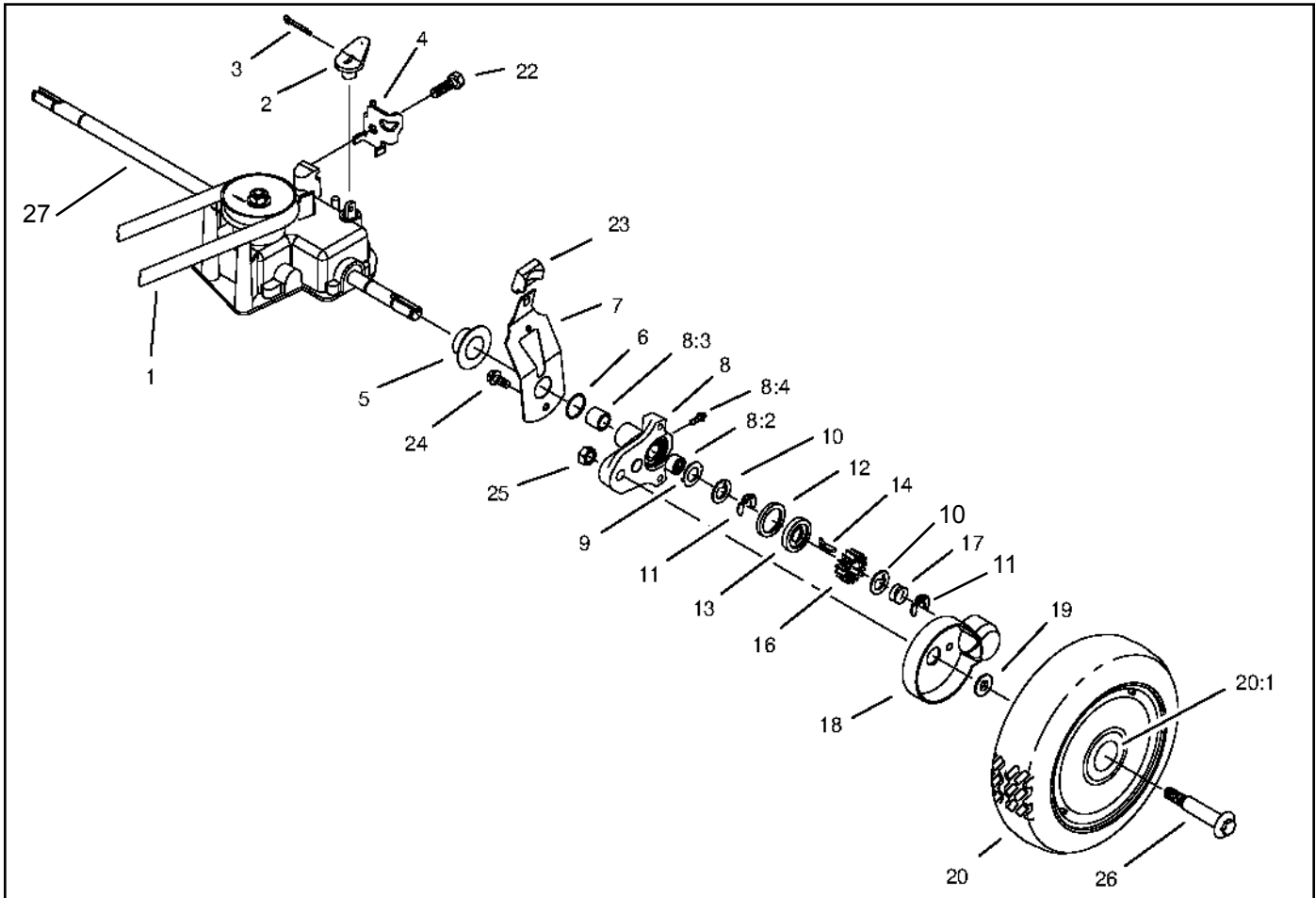

Fig 168 gear case wheel assy

Ref. No.	Qty	Description
1	1	V-Belt
2	1	Lever-Shift
3	1	Pin-Cotter
4	1	Clamp-Cable
5	2	Cap-End
6	2	O-Ring
7	2	Spring Arm ASM
8	2	Pivot Arm ASM
8:2	1	Bushing
8:3	1	Bushing
8:4	1	Fitting-Zerk
9	2	Washer-Arm, Pivot
10	4	Washer-Thrust, Keyed
11	4	Ring-Klip
12	2	Ring-Friction

Ref. No.	Qty	Description
13	2	Washer-Clutch
14	1	Key-Rocking, LH
*15	1	Key-Rocking, RH
16	2	Gear-Pinion
17	2	Spring-Compression
18	2	Cover-Wheel
19	2	Spacer-Cover, Wheel
20	2	Wheel ASM
20:1	2	Bushing
22	1	Screw-HH
23	2	Knob-Arm
24	2	Screw-HH
25	2	Nut
26	2	Bolt-Shoulder
27	1	Output Shaft

\*Not illustrated

# WHEEL PINION CLUTCH

## Wheel Pinion Clutch

The wheel pinion clutch has a three-fold purpose. One, when the transmission is engaged, it causes the pinions to move with the output shaft and drives the wheels. Two, it provides differential action to allow easy turning and excellent maneuverability. Three it disengages the wheel pinions from the output shaft when the operator is not squeezing the handle. This allows the wheels to turn backwards without turning the gears inside the transmission and provides low pull back forces similar to those on a hand-push version (Fig. 169).



Fig 169

3428-0028

## Component Definitions

27. *Output Shaft* – turns when the operator squeezes the handle to provide power to the wheels.
8. *Pivot Arm Assembly* – provides support for the output shaft with a bushing and a needle bearing. It can be rotated in the end cap to change height-of-cut.
9. *Washer Pivot Arm* – fits in corresponding recesses on the pivot arm to protect pivot arm from premature wear.
10. *Keyed Thrust Washer* – internal tab fits in the keyway on the output shaft. This washer rotates with the output shaft and protects outboard clutch components from wear.
11. *Clip Ring* – fits in a groove on the output shaft to retain the pivot arm and spring arm. The tab at the center of the clip is extended and fits in the keyway of the output shaft to prevent rotation. If an E-clip is substituted, premature failure of the wheel pinion clutch system will result.
12. *Friction Ring* – fits in a circular groove in the pivot arm and works with the clutch washer to actuate the key. It does not rotate.
13. *Clutch Washer* – is affixed to the output shaft by means of the key so it turns with the output shaft. It is also allowed to rotate slightly with respect to the output shaft. This slight back and forth rotation actuates the wheel pinion key. Friction between the clutch washer and friction ring causes the clutch washer to lag the output shaft slightly once it is engaged. That slight rotation is all that is necessary to raise the wheel pinion key and engage the pinion.
14. *LH Rocking Key* – causes the wheel pinion to turn with the output shaft when up. Allows the wheel pinion to “free-wheel” when down. Clutch washer brings key up. Wheel pinion turning forward “wipes” key down. There is a left-hand and right-hand key.
15. *RH Rocking Key* – causes the wheel pinion to turn with the output shaft when up. Allows the wheel pinion to “free-wheel” when down. Clutch washer brings key up. Wheel pinion turning forward “wipes” key down. There is a left-hand and right-hand key.
16. *Pinion Gear* – positively engages the wheel gear at all times. Engagement with the output shaft is controlled by the wheel pinion key. The wheel pinion is a powdered metal part and is symmetrical so that it can be put on either way and still function properly.
17. *Compression Spring* – provides the light, constant, inward force necessary for proper clutch washer and friction ring engagement.

It is extremely important that the wheel pinion clutch be maintained according to the instructions in the operator's manual, which is greasing every 25 hours with one or two pumps of grease. Greasing regularly will prevent contaminants from damaging or wearing the system.

**Note: Over-greasing will also cause the system to malfunction.**

# WHEEL PINION CLUTCH

---

## Test for Function

### Function

The rocking keys provide a differential action by engaging and disengaging each drive wheel individually.

When the drive is engaged and the axle begins to turn, friction between the friction ring and clutch washer cause them to rotate the tail on the key. This results in the main part of the key engaging the teeth on the inside of the pinion gear.

Should one or both wheels turn faster than the axle, the pinion rotates and pushes the key back down into the groove. The pinion can now roll freely over the key. When turning the inside wheel will drive the mower. The outside wheel must turn faster and overrides the key. When the mower is straightened out the pinion is no longer turning faster than the axle so the key re-engages the pinion.

To operate this system, practice the following. Walk along at a normal pace. When you stop walking, keep your elbows at your sides. The mower will continue forward for a few inches due to its momentum. As the mower rolls away, the drive will disengage as the Personal Pace/ Easy Stride handle extends and disengages the transmission. From the point where the transmission is no longer turning the axle, the mower must roll about 1-1/2" forward. This causes the pinions to rock the drive keys to the disengage position. At this time the mower can be pulled backward with minimal effort. When the drive is engaged and the axle begins to turn the keys should re-engage.

## Quick Test

If you are unsure that the keys are disengaging properly, stop the mower, shut the engine off and push the mower forward a few inches. If the keys disengage the system is working correctly. Start the engine and engage the drive, if both engage they are OK. If one or the other do not engage or disengage properly try greasing the pivot arm. Use #2 lithium grease and only one or two pumps from a hand grease gun. If grease does not help disassembly is necessary.

## Rear Height-of-Cut and Wheel Pinion Clutch - Disassembly

The rear height-of-cut system and the wheel pinion clutch can be serviced with the transmission in or out of the unit. For information on removing the transmission from the unit, see Transmission – Removal, page 3-3, 5-5 or 5-6 depending on mower type.

1. Remove the shoulder bolt securing the wheel and tire assembly to the pivot arm and remove the wheel and tire assembly complete with shoulder bolt, spacers, wheel cover, and nylon locknut.
2. Remove the special retaining clip at the end of the output shaft and pull off the following six wheel pinion clutch components:
  - Spring
  - Internally tabbed thrust washer
  - Wheel pinion
  - Wheel pinion key
  - Clutch washer
  - Friction ring
3. Remove the inner special retaining clip from the output shaft and remove the following components:
  - Internally tabbed thrust washer
  - Externally tabbed thrust washer
  - Pivot arm and spring arm assembly
  - End cap (if desired)

# WHEEL PINION CLUTCH

4. Check all components at this time for damage and wear. Pay particular attention to the grooves at the end of the output shaft, the bearing surfaces on the output shaft, and the wheel pinion clutch components. Replace parts as necessary.
5. Check the innermost groove on the output shaft which is located 2-1/4" (5.7cm) in from the end of the shaft; make sure that the O-ring seal is present and intact. This seal is important to keep grease in and contaminants out. Replace it (Item 6) if necessary (Fig. 170). Some models do not have this O-ring.

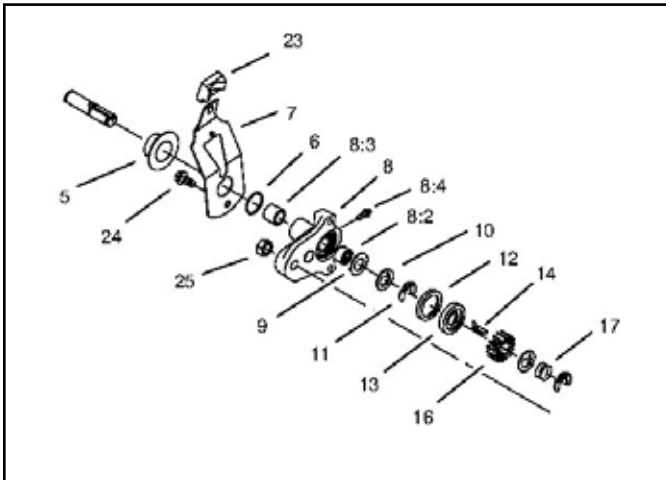

Fig 170 gear case wheel assy 2

6. Press the needle bearing and the oil impregnated bushing from the pivot arm using an arbor press.
7. Removal of the grease fitting is not recommended because it is pressed in. However, if damaged or lost, we suggest tapping and installing a threaded grease fitting.
8. If the spring arm knob requires replacement, push in on the detent tab, then pull the knob straight off.

**Note:** The detent rivet is not replaceable.

## Rear Height-of-Cut and Wheel Pinion Clutch - Assembly

1. Pack the caged needle bearing with grease, then press into the outside of the pivot arm until it is flush with the groove that houses the externally tabbed thrust washer.
2. Press the oil impregnated bushing into the boss on the pivot arm until it is flush with the face of the boss.
3. If spring arm disassembly was required, install the knob making sure that the detent is pressed out about .060" (1.5mm). Install the spring arm knob so that the concave side of the knob and the convex side of the rivet align.
4. Assemble the spring arm and pivot arm as shown in Figure 171.

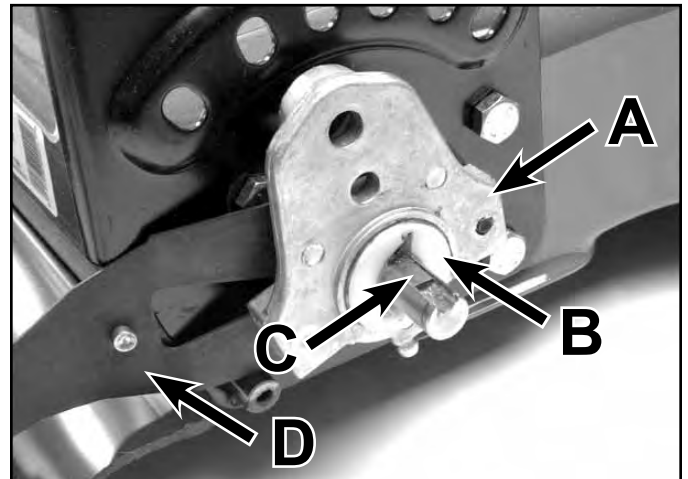

Fig 171

3428-0028

- |                    |               |
|--------------------|---------------|
| A. Pivot arm       | C. Key        |
| B. Friction washer | D. Spring arm |

# WHEEL PINION CLUTCH

5. To increase service life, make sure all parts are clean prior to assembly and coated with new grease.
6. If removed, install a new O-ring in the innermost groove 2-1/4" (5.7cm) in from the end on each output shaft, making sure that it is fully seated in the groove. Refer to Figure 171 above. Not all models use an O-ring.
7. Slip the end cap onto the output shaft, but do not fasten at this time.
8. Slide the pivot arm and spring arm assembly onto the output shaft, boss first.

**Note: The convex side of the spring arm rivet and the concave side of the knob on the spring arm should both be facing the housing.**

9. Slide the externally tabbed thrust washer and the internally tabbed thrust washer onto the output shaft. Make sure that the tab on the internally tabbed thrust washer enters the keyway. Secure with the special retaining clip. Make sure that the center tab fits properly into the keyway. This will prevent rotation of the clip on the output shaft.
10. Place the friction ring into the groove on the pivot arm, flat side out.
11. Slide the clutch washer onto the shaft so that the recesses for the key are facing out.

12. Place the wheel pinion key in the groove on the output shaft with the leg toward the clutch washer.

**Note: There is a left and a right wheel pinion key. You are using the correct key if, when placed in the groove, the top of the key is flat and the straight portion of the leg is perpendicular to the shaft.**

Before assembling further, rotate the clutch washer back and forth slightly, making sure that the key actuates properly (Fig. 172).

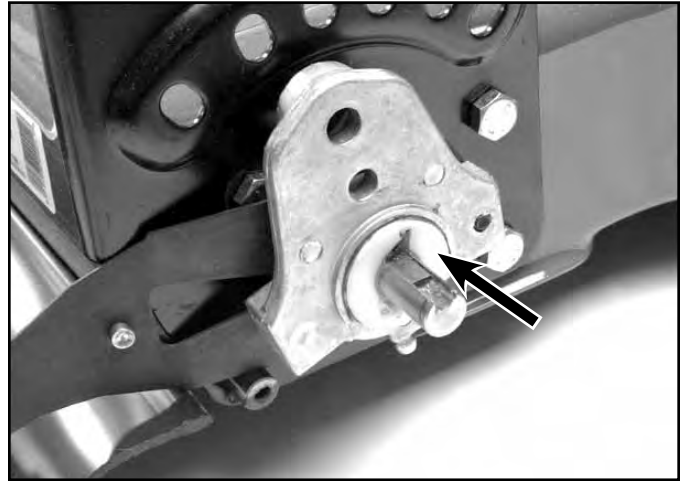

Fig 172

3428-0028



# WHEEL PINION CLUTCH

13. Place the wheel pinion onto the output shaft. It is symmetrical and can be put on either way.
14. Install the internally tabbed thrust washer onto the output shaft making sure that the tab enters the keyway.
15. Slip the spring onto the end of the output shaft and secure with the special retaining clip. Again, make sure that the center tab fits properly into the keyway to prevent rotation of the clip (Fig. 173).

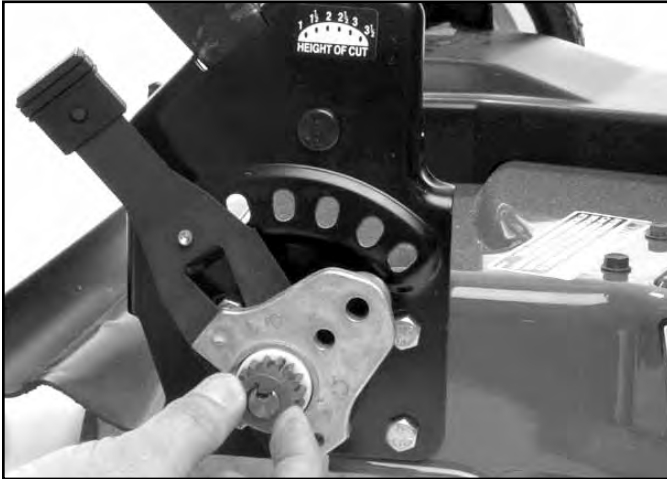

Fig 173

3428-0040

16. Slip the wheel, the original number of spacers, and the wheel cover onto the shoulder bolt and secure to the pivot arm using the nylon locknut.
17. Grease with No. 2 lithium-based grease. Use a hand grease gun to avoid excess pressure that may prevent the friction parts from working. As a rule, use two pumps to ensure that you do not over-grease. Be sure to grease after every 25 hours of use for maximum service life.

# WHEEL PINION CLUTCH

## GEAR CASE AND WHEEL ASSEMBLY, SPRING RATCHET STYLE

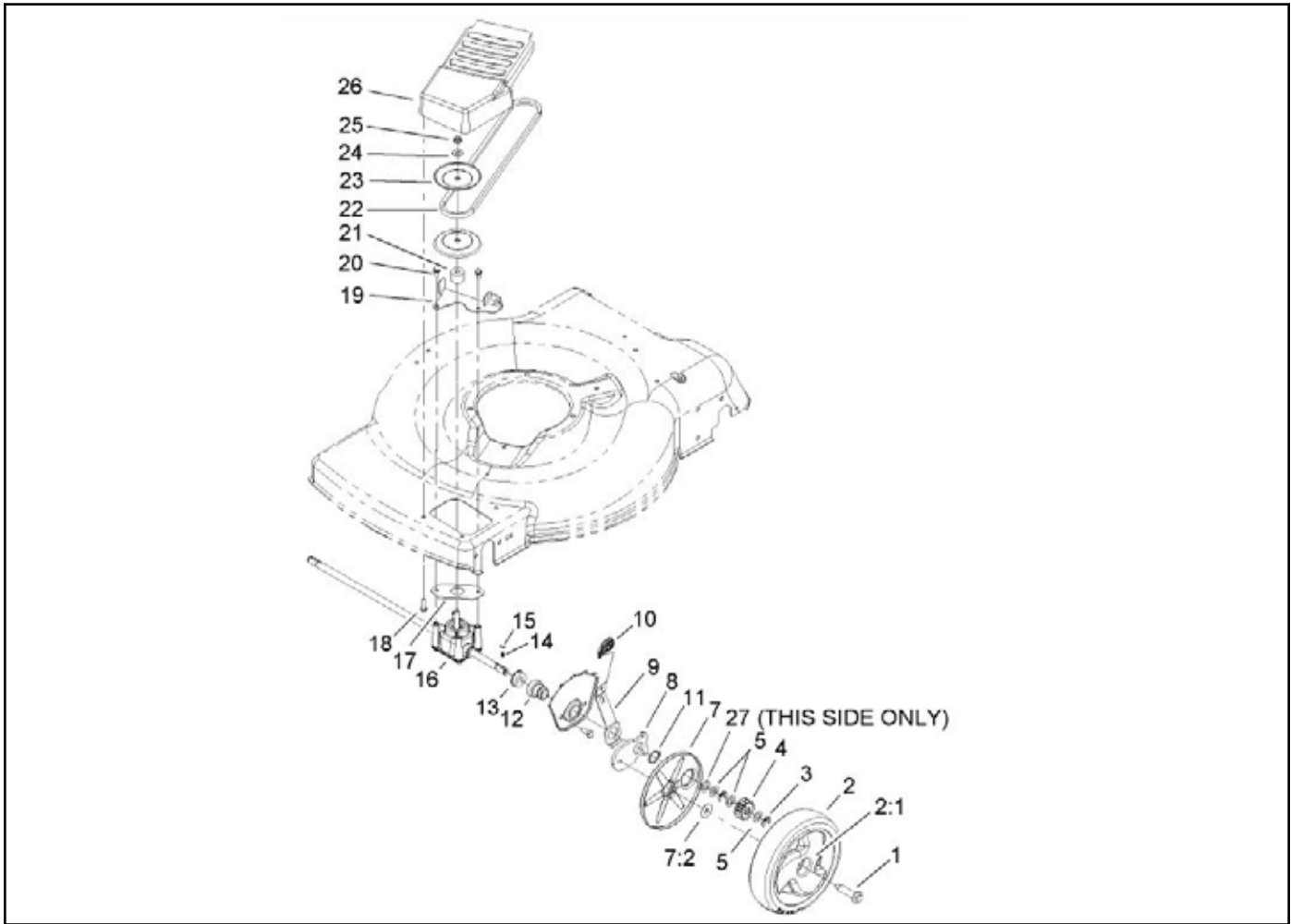

Fig 174

3354-613\_5

Ref. No.	Qty	Description
1	2	Bolt-Shoulder
2	2	Wheel Gear ASM
2:1	2	Bushing
3	4	Klipring-Locking
4	2	Gear-Pinion, 13T
5	6	Washer-Thrust
7	2	Cover-Wheel
7:1	1	Cover
7:2	1	Washer-Stepped
8	2	Arm-Pivot, Front
9	2	Arm-Spring
10	2	Knob-Lever, HOC
11	2	Ring-Retaining
12	2	Retainer-Bearing, HOC
13	2	Bearing-Ball

Ref. No.	Qty	Description
14	2	Spring-Compression
15	2	Key
16	1	Transmission ASM
17	1	Gasket-Gearbox
18	2	Screw-HWH
19	1	Bracket-Pivot, Fwd
20	2	Screw-HWH
21	1	Spacer
22	1	V-Belt
23	2	Pulley-Half, Front
24	1	Washer-Flat
25	1	Nut-Lock
26	1	Cover-Belt, Front
27	1	Washer

# WHEEL PINION CLUTCH

## Spring Ratchet Style

The Spring Ratchet type wheel clutch system has been used on a wide variety of models. It consists of a spring supporting a drive key which engages the pinion. When the mower drive is engaged the axle turns the key which is engaged with an internal tooth on the pinion. The pinion turns the wheel gear. When the mower is pushed or turned, the pinion must rotate faster than the axle. As the pinion rotates it depresses the key, allowing the differential action.

The axle drives both keys and pinions equally but they will ratchet individually. When the mower is pulled backwards, this type of clutch does not disengage. It will require the axle and transmission to turn backwards. It is critical to easy backing to make sure the self-propel belt properly disengages.

## Servicing the System

The things that can impede the function are dirt, rust or wear. The owner's manual requires that ordinary engine oil be added to each side of the pinion periodically. This is to keep the anti seize from drying up. If that is not done, it will be necessary to remove the pinion, key and spring to clean and re-lubricate with anti-seize compound.

On the left side there will be two keyed thrust washers and one regular thrust washer. Clean the end of the axle, keyway, and the parts removed. Inspect the key; if worn, replace. Make sure the thrust washers have the key tab on them. If the tab is broken, the pinion will tend to push the retaining rings out of their grooves.

Lubricate the key, spring, and axle with anti-seize compound and reassemble. Note the pinion has the letter "R" stamped on one side and "L" on the other. If you are on the right side of the mower, the letter "R" should face you when you install the pinion. The letter "L" should be visible on the left side of the mower.

## WHEEL PINION SERVICE

The steps to service the wheel pinions are the same for both front and rear wheel drive models.

1. Raise the mower until the wheel is off the ground. Support with a block.
2. Remove the wheel bolt, wheel and wheel cover (Fig. 175).



Fig 175

MVC-739

3. Remove the retaining ring and thrust washer (Fig. 176).

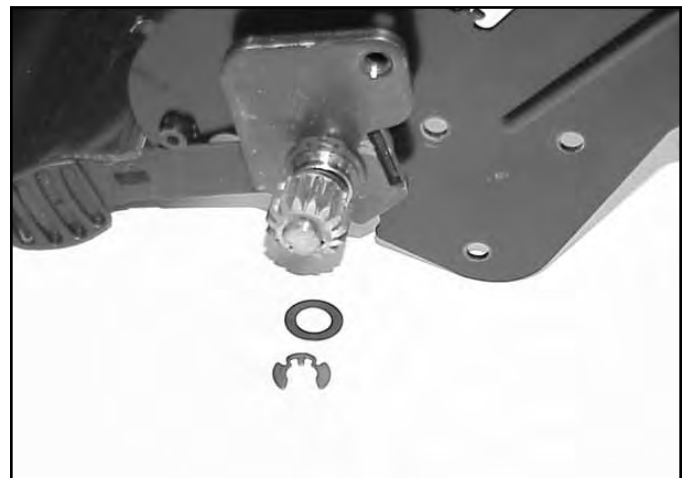

Fig 176

MVC-746

# WHEEL PINION CLUTCH

- Slide the wheel pinion off the axle.

**Note:** There is a spring-loaded key under the pinion (Fig. 177).

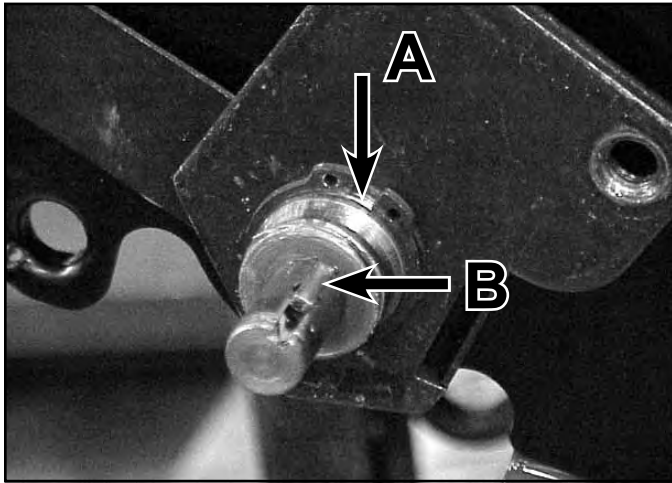

Fig 177

MVC-850

- A. Retaining ring and thrust washer      B. Key

- Behind the pinion should be another thrust washer and retaining ring (Fig. 144).

Reassemble in reverse order:

- Install one thrust washer, then the first retaining ring with the sharp edge facing the chassis (Fig. 178).



Fig 178

MVC-472

- Lubricate with anti-seize and assemble in the original order.

Safety Information . . . . . 1

Worm Drive Transmission . . . . . 2

Single Speed Spur/Bevel Gear Transmission . . . . . 3

Single Speed Bevel Gear Transmission . . . . . 4

Three Speed Transmission . . . . . 5

General Transmissions® . . . . . 6

Wheel Pinion Clutch . . . . . 7

**Blade Brake Clutch Systems (BBC), Blade Override System (BOS), Blade Clutch Systems (BCS) . . . . . 8**

Handles and Control Cables . . . . . 9

Self-Propel Belt Replacement . . . . . 10

## BLADE BRAKE CLUTCH SYSTEM (BBC)

### Description

There are two basic blade clutching system designs. The first is commonly referred to as the BBC or Blade Brake Clutch. It has two versions which have been used on many Toro models as well as Lawn-Boy Medallion mowers. The second design was introduced in 2005 and is used on Toro (Blade Override System) and Lawn-Boy (Blade Clutch System) (Fig. 179 and Fig. 180).



Fig 179

3428-0001



Fig 180

3428-0004

The blade clutch system offers the customer convenience to stop the blade while allowing the engine to continue to run.

Before troubleshooting the BBC deck mechanism, be sure that it is adjusted properly. Refer to the BBC cable adjustment section for proper adjustments.

### BBC Clutch Operation

The clutch operates by using a flywheel which turns with the engine crankshaft and a brake drum and blade that are free to turn separately from the flywheel. The two are connected by tensioning a drive belt between the flywheel and brake drum. The combination idler arm and brake controls the belt. When the control is engaged, the idler with the brake pad backs away from the brake drum and tightens the belt. When the control is released, a spring causes the idler to pivot towards the brake drum releasing the belt and engaging the brake. This stops the blade but allows the flywheel and crankshaft to continue to turn.

### BBC Control Box Operation

The BBC control mechanism's purpose is to actuate the deck mechanism. It does this by tensioning and loosening the BBC cable. The control mechanism meets the federal government's "2-step" blade engagement procedure. The traction drive can also be integrated with this control system.

The normal or “at rest” position of the control bar is indicated by the number 1 in the Figure 181. In order to engage the blade, the operator must first “cock” the control bar down to position 2, then raise the control bar to position 3.

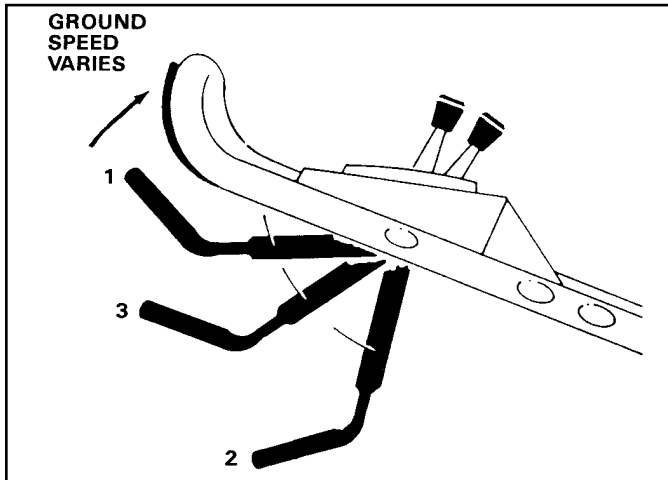

Fig 181

fig 27

Notice that position 3 is approximately 5” (12cm) below the handle. This distance between position 3 and the handle is reserved for engagement of the transmission on those models equipped with self-propel. On units without self-propel, the control bar can be lifted to the handle without affecting operation of the BBC system.

After engagement of the blade, release of the control bar disengages the blade and, on self-propel models, the transmission. By gradually releasing the control bar, the operator can regulate the ground speed of self-propel models without disengaging the blade.

## Handle Controls

The control box components and their functions (Fig. 182) are described below.

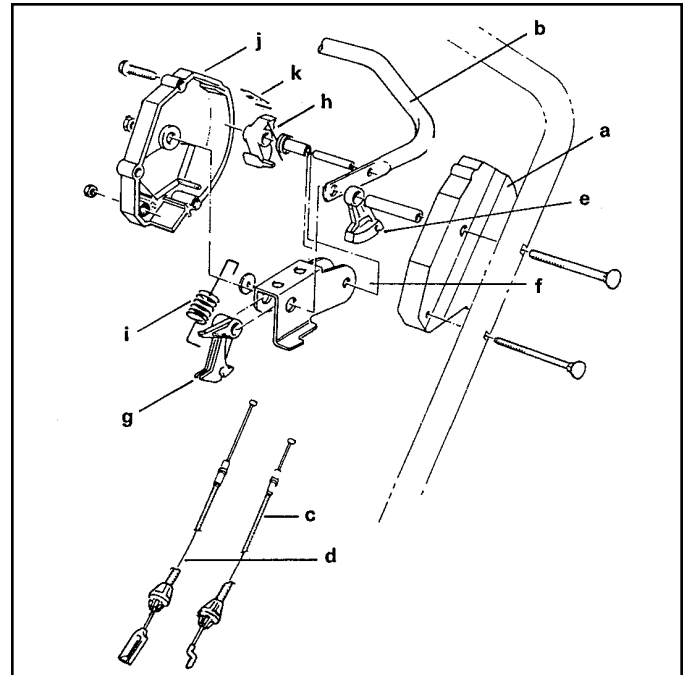

Fig 182

fig. 28

- a. *Left Control Housing*: serves as the cover for the BBC control mechanism. It also houses the end of traction and BBC cables.
- b. *Control Bar*: pivots on upper shoulder bolt. Transfers operator inputs to control box components.
- c. *Traction Cable*: engages the transmission by transferring inputs from the control box. The transmission is engaged when the cable is tightened; disengaged when the cable is loosened.
- d. *BBC Cable*: transfers inputs from the control box to the BBC deck mechanism.

# BBC / BOS / BCS

- e. *Traction Lever*: provides input to the traction cable since the end of the traction cable is retained in it. It also pivots on the upper shoulder bolt when the control bar is moved.
- f. *Rocker Arm*: pivots on the upper carriage bolt. It is affixed solidly to the control arm by means of the roll pin. It houses both the control hook and cable lever. It also provides slot and stop for the buckling spring.
- g. *BBC Cable Lever*: controls tensioning and loosening of the BBC cable since the end of the BBC cable is retained by it. Pivots freely on the upper carriage bolt. Movement is controlled by the control hook.
- h. *Control Hook and Spring*: pivots on the roll pin and is spring-loaded in the counterclockwise direction by the torsion spring. The control hook “grabs” the cable lever when the control bar is cocked and releases the cable lever when the control bar is dropped.
- i. *Buckling Spring*: sole purpose is to hold the control bar in the middle position when at rest. The spring is flexed or “buckled” when the control bar is operated. It rides in a slot on the rocker arm to prevent it from applying force to the control bar when the control bar is at its lowest or uppermost positions.
- j. *Right Control Housing*: serves as the other half of the control box cover. Houses the leaf spring.
- k. *Leaf Spring*: releases the control hook as the control bar drops to “at rest” position. Because of its orientation, it allows the control hook to slip by as the control bar is raised.

These components interact to provide control to the BBC deck mechanism. Notice in Figure 183 the position of the traction cable lever and the BBC cable lever. This is the “at rest” position; both the BBC and the transmission are disengaged. When the control bar is in this position, it is the buckling spring that supports it. Notice that the buckling spring is not flexed and is at the left end of the slot in the rocker arm.

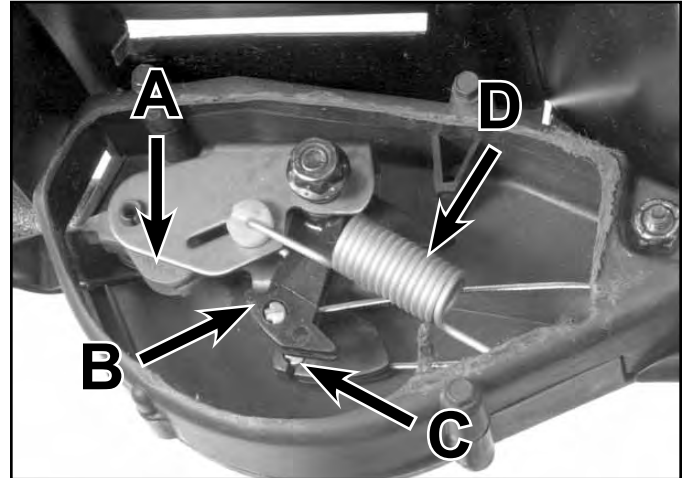

Fig 183

3428-0278

- A. Control hook
- B. BBC cable lever
- C. Traction cable lever
- D. Buckling spring



When the control bar is cocked to its lowest position as in Figure 184. The buckling spring is flexed and moved to the right end of the rocker arm slot. Another event takes place inside the rocker arm: The spring-loaded control hook slides over the cable lever and grasps it so that when the lever is raised, the BBC cable will come with it.

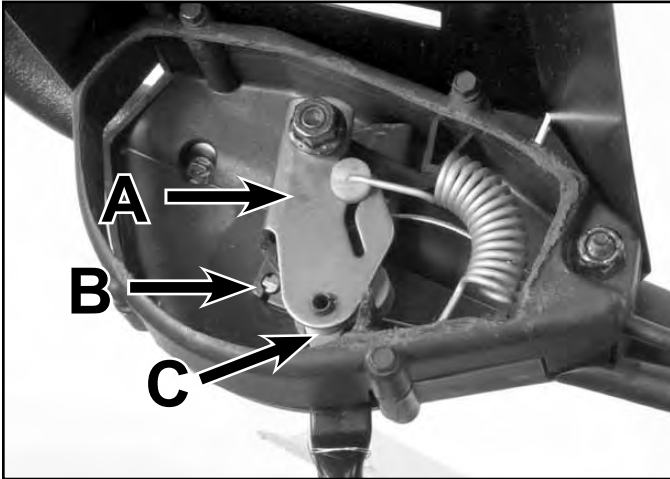

**Fig 184** 3428-0286

- A. Rocker arm
- B. BBC cable lever
- C. Control hook

When the control bar is raised to a point 5" (12.7cm) below the handle, the BBC cable has been tightened enough to engage the blade (Fig. 185).

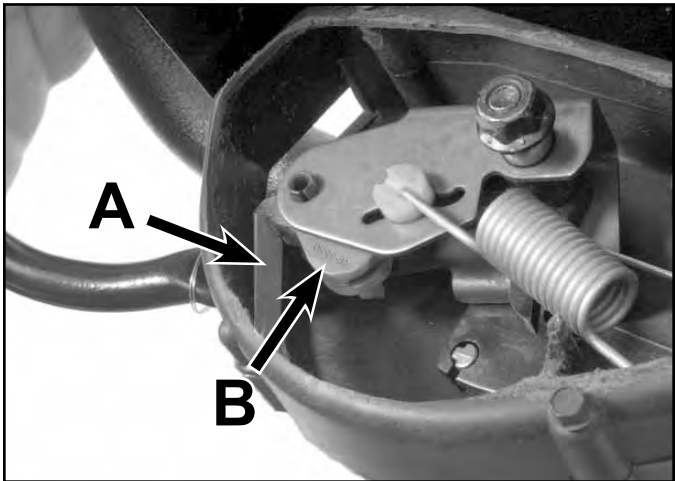

**Fig 185** 3428-0289

- A. Leaf spring
- B. Control hook

Raising the control bar straightens the buckling spring. Also important is the function of the leaf spring. As the control bar is raised, the left tip of the control hook slips by the leaf spring without causing release of the cable lever.

Continuing to raise the control bar causes the traction lever to move and the traction cable engages the transmission.

When the control bar is released, the tip of the control hook catches on the leaf spring causing it to rotate. This releases the BBC cable lever, thereby causing the BBC to declutch and apply the blade brake (Fig. 186).

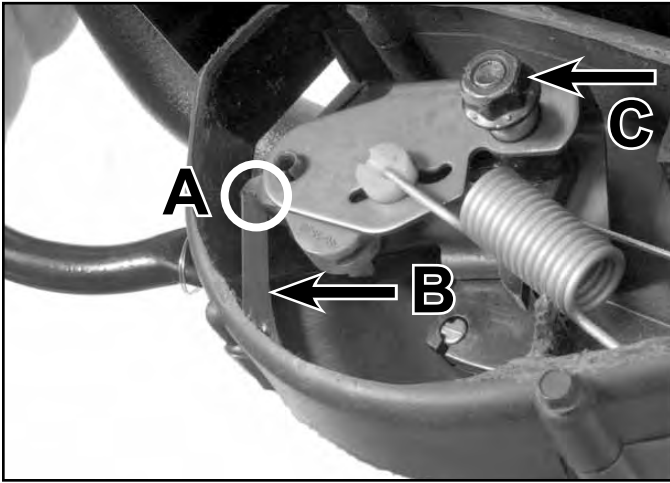

Fig 186

3428-0290

A. Contact point  
B. Leaf spring

C. Flange nut

## Control Box Disassembly

**Note:** When servicing the BBC control box, be careful not to disassemble the unit any further than necessary as it will then become difficult to trouble shoot. Instead, remove the right housing half, then operate the control box while watching for proper function of internal components. See Step 5 below for more information.

1. Place a piece of duct tape over the heads of the carriage bolts passing through the handle and the BBC control box. This will prevent them from falling out later during troubleshooting.
2. Bend the locking tab securing the throttle control to the control panel, then tap the throttle control out using a rubber mallet.
3. Remove the 3 flanged head screws retaining the 2 control box halves.
4. Carefully remove the 2 flange nuts retaining the control box to the handle and remove the right control box half. Be careful not to dislodge any internal components.
5. Reinstall the flange nuts to help hold things together. Determine if any of the components inside the control box are malfunctioning.

**CAUTION!** Wear gloves and eye protection when operating an open control box as the buckling spring could fly out.

**Note:** The cable ends and end of the spring are not retained once the right cover is removed. Be sure to use one of the two methods below to retain them.

The first and quickest method is to manually hold the ends of the cable and the end of the buckling spring while operating the control bar. However, with the right case half removed, the leaf spring is no longer in place and you will not be able to observe release of the BBC cable lever.

A better method is to make a special cut-away version of the right control box housing half as shown in Figure 187. When this cut-away version is installed, all components will function normally. Notice the cut-away cover and how it houses the leaf spring. This will aid in diagnosis.

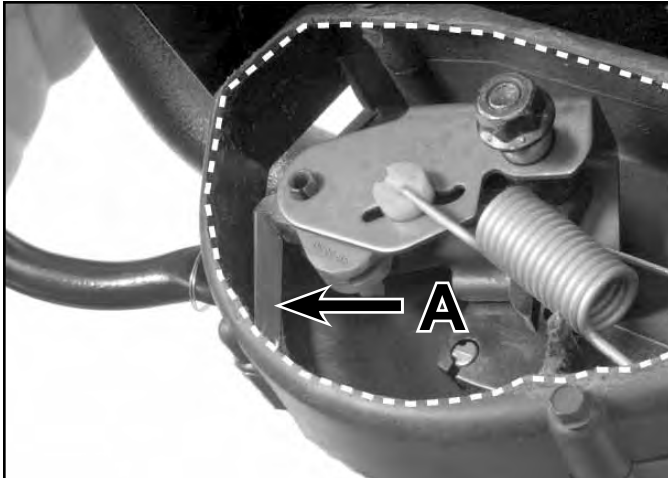

Fig 187

3428-0289b

A. Leaf spring

6. If further disassembly is required, remove the buckling spring and washer from the rocker arm assembly.
7. Remove the BBC cable from the BBC cable lever and the left-hand control box half.
8. Remove the rocker arm as an assembly, complete with cable lever and control hook.
9. Remove the cable lever from the rocker arm assembly.
10. Press the roll pin from the rocker arm and remove the control hook and torsion spring.
11. Remove the traction cable from the traction lever and the left-hand control housing.

12. Pull the tape from the outside of the handle. Remove the upper carriage bolt along with the cable lever and spacer.
13. Remove the lower carriage bolt and remove the left control housing.
14. Inspect all parts for wear and/or damage and replace as required.

## Control Box Assembly

1. Slip the lower carriage bolt through the handle, then slide the left control housing onto it.
2. Slip the end of the traction cable into the traction lever. Place the control housing, traction lever, and the control bar into position as shown in Figure 188. Once in position, slide the carriage bolt through all three components.

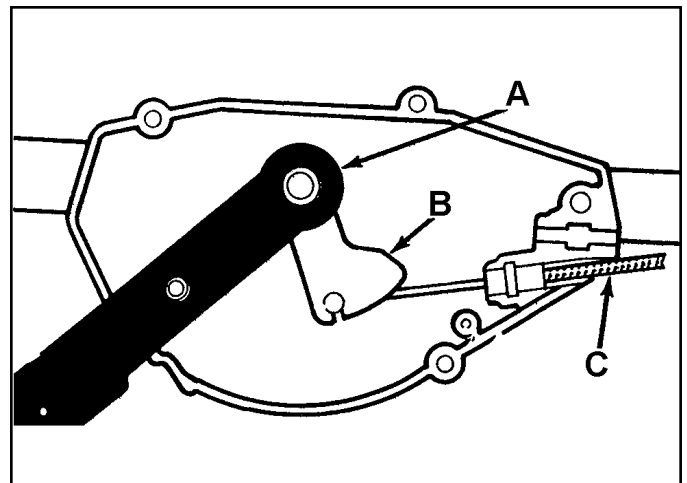

Fig 188

fig 34

A. Leaf spring  
B. Traction lever

C. Traction cable

# BBC / BOS / BCS

3. Place a piece of duct tape over the heads of the carriage bolts that slide through the handle and the left control box housing. This will aid in assembly.
4. Slide the sleeve onto the upper carriage bolt making sure that it passes through the control bar, traction lever, and left control housing.
5. Position the control hook and torsion spring in the rocker arm as shown in Figure 189. Secure with the roll pin making sure that the roll pin is flush with the side indicated in the figure. Loosely install the BBC cable lever as indicated. When correctly installed, the control hook and the cable lever will be engaged.

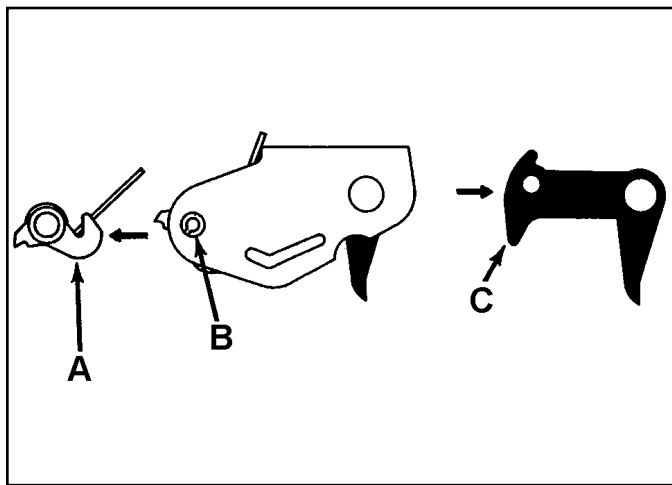

Fig 189

fig 35

- A. Control hook
- B. Roll pin flush with this side
- C. Cable lever

6. Slide the rocker arm assembly over the upper carriage bolt and sleeve making sure that the sleeve passes through the cable lever. Also make sure that the roll pin passes through the hole in the control bar.
7. Release the BBC cable lever from the control hood and install the BBC cable into the cable lever (Fig. 190).

**Note: The BBC cable lever is behind the spring.**

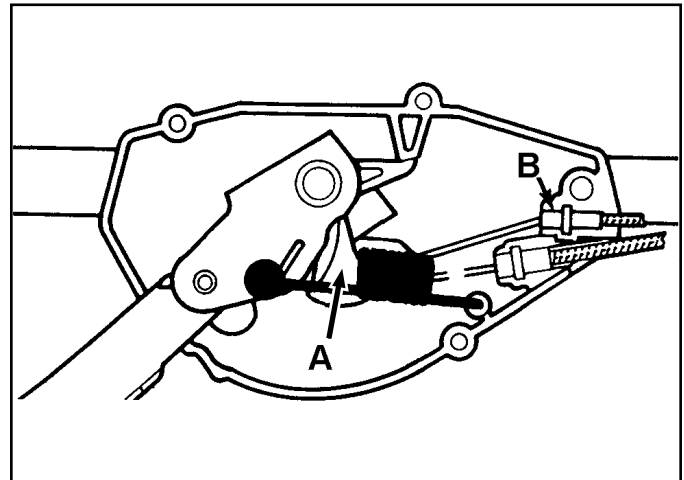

Fig 190

fig 36

- A. BBC cable lever
- B. BBC cable

- Slip the white nylon washer onto the J end of the buckling spring. The slotted side of the washer should face away from the end of the spring. Slip the spring into position in the rocker arm and the left control housing as shown in Figure 191.

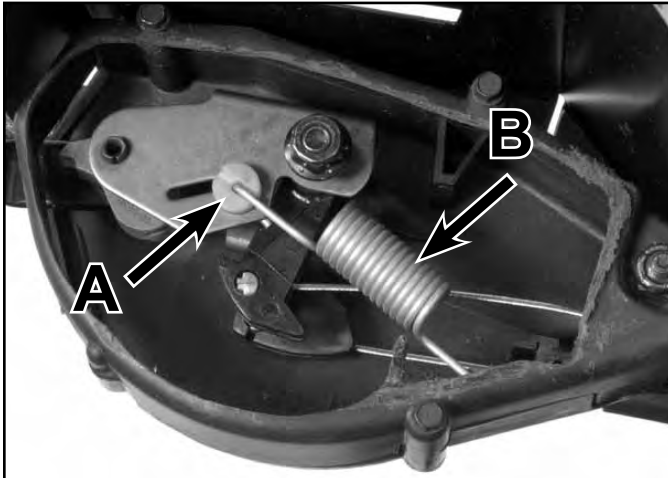

Fig 191

3428-0281

- A. Nylon washer                      B. Buckling spring

- Assemble the right control housing by installing the leaf spring and pin to retain the leaf spring (Fig. 192).

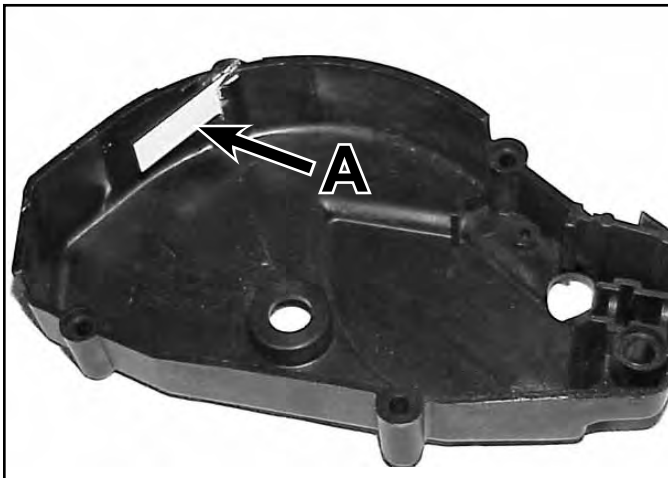

Fig 192

MVC-488

- A. Leaf spring

- Before installing the right control housing, check to make sure that both cable sheath ends are fully seated in their slots in the left housing. Also make sure that the sleeve passes through all components including the left control housing. Finally, make sure that the roll pin passes through the rocker arm and control bar.

Install the right control housing and secure with the 2 nylon locknuts or 1 locknut and 1 flange nut.

- Install the 3 flanged head screws that retain the two control box halves.
- Check for proper operation of the entire BBC system. Correct as required.
- Bend the throttle control locking tab forward to provide positive lock with the throttle control and install the throttle control.
- Adjust the BBC cable and traction cables as needed. See page 7-16.

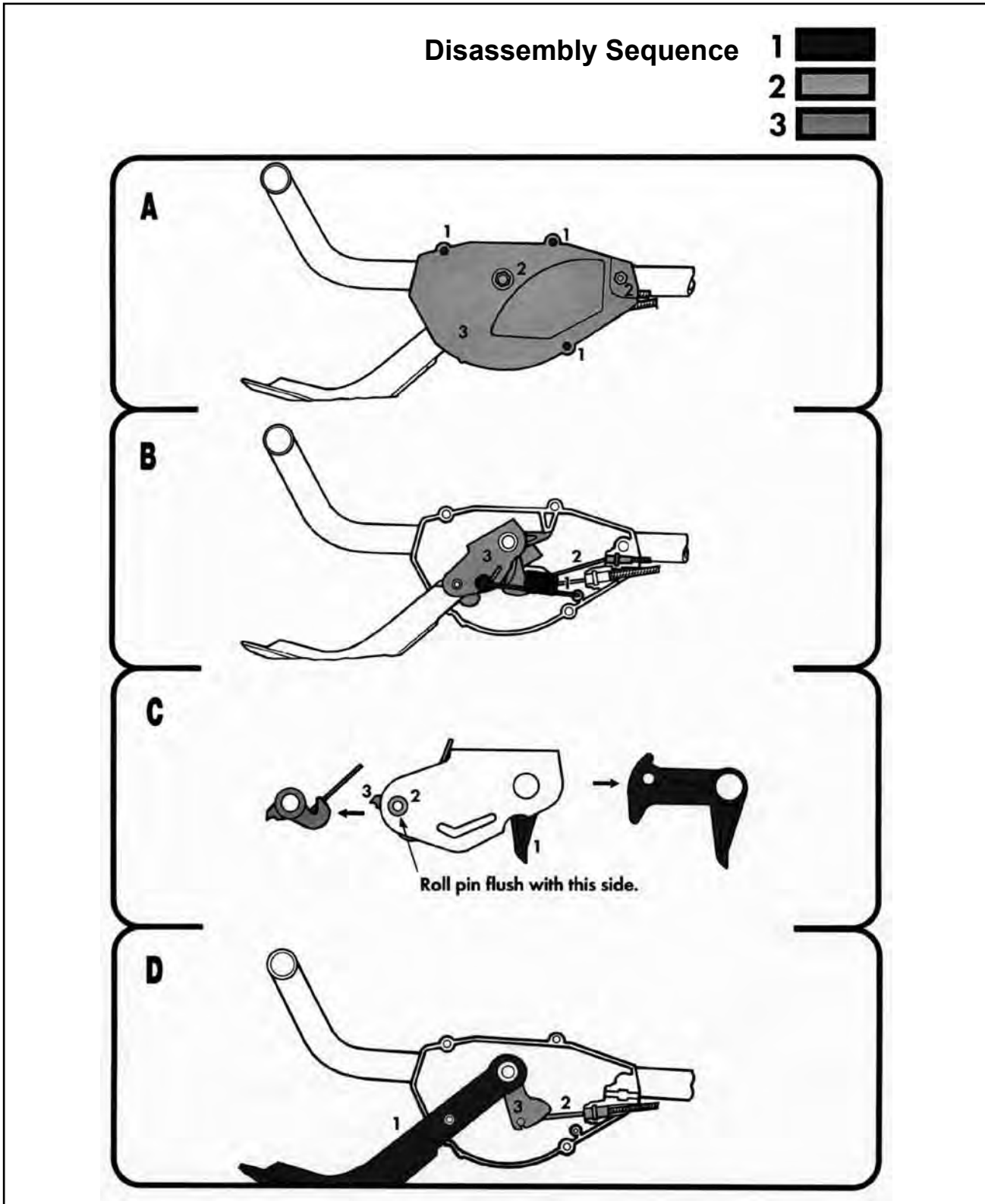
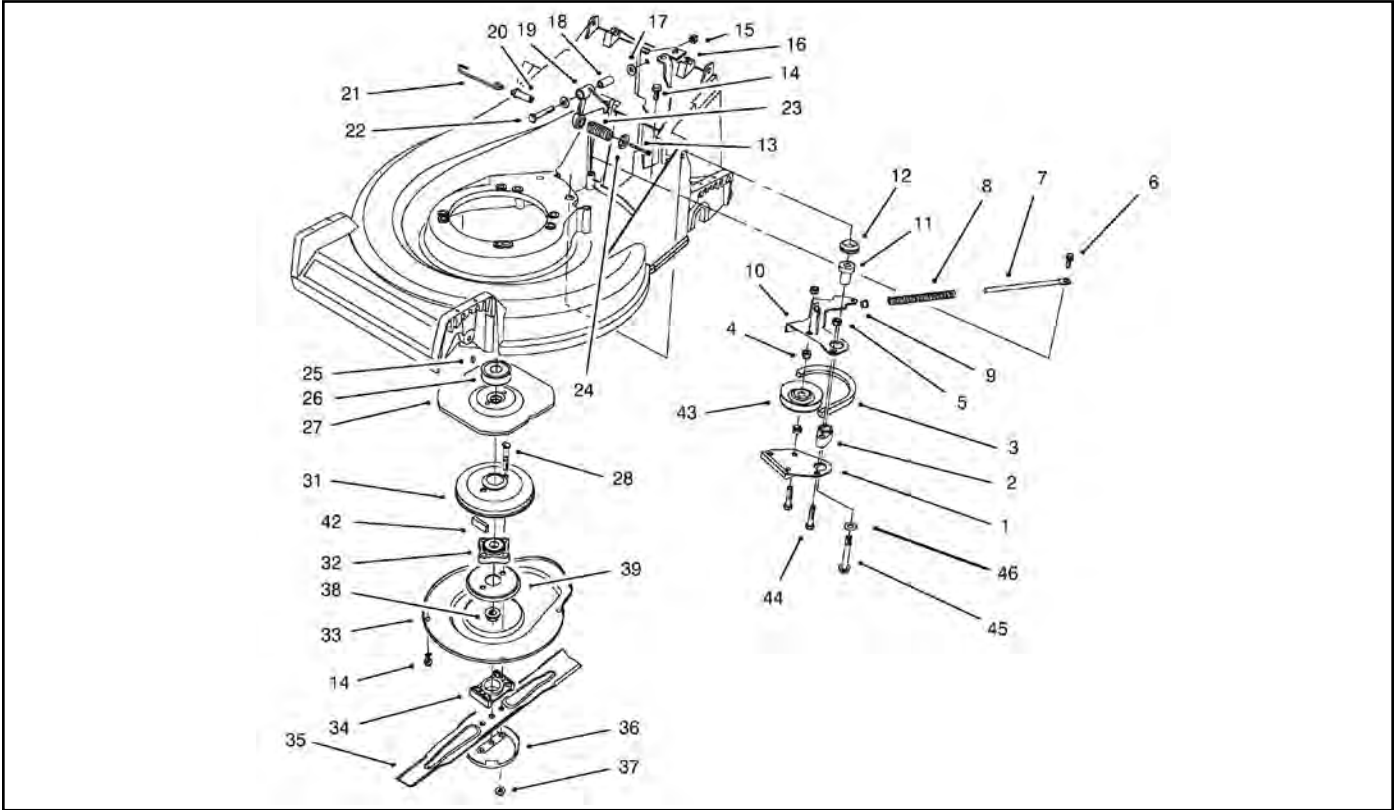

Fig 193

bbc scan

**BLADE BRAKE CLUTCH ASSEMBLY (Toro Vacu Power/Lawn-Boy Medallion BBC)**



**Fig 194** blade brake clutch assy

Ref. No.	Qty	Description
1	1	Brake Shoe
2	1	Plate Hub
3	1	V Belt
4	2	Pulley Hub
5	2	Lock Nut
6	1	Spring Rod
7	1	Shoulder Bolt
8	1	Compression Spring
9	1	Flange Bushing
10	1	Lever Wa
11	1	Bushing
12	1	Ring Seal
13	1	HWH Screw
14	5	TAP Screw
15	1	Flange Nut
16	1	Cable Bracket Support
17	2	Flat Washer
18	1	Bellcrank Bushing
19	1	Crank
20	1	Spring Pin
21	1	Control Link

Ref. No.	Qty	Description
22	1	HH Screw
23	1	Compression Spring
24	1	Spring Retainer
25	1	Woodruff Key
26	1	Driver Pulley
27	1	BBC Flywheel
28	2	Blade Bolt
31	1	Brake Drum
32	1	Hub ASM
33	1	BBC Shield
34	1	Blade Spacer
35	1	21" Blade
36	1	Anti Scalp Cup
37	2	Lock Nut
38	1	Lock Nut
39	1	BBC Screen
42	2	Vibration Damper
43	1	Idler Pulley
44	2	HH Screw
45	1	Thd Forming Screw
46	1	Flat Washer

# BBC / BOS / BCS

## TORO VACU POWER/LAWN-BOY MEDALLION BBC



Fig 195

DSC-068a

2. Pull the black plastic transmission cover up to remove it from the housing (Fig. 197).



Fig 197

3428-0082

### Bellcrank System Disassembly (Toro Vacu Power/Lawn-Boy Medallion)

1. Remove the flanged head self-tapping capscrews securing the upper BBC cover to the housing and remove the upper BBC cover (Fig. 196).



Fig 196

3428-0079

3. Remove the shoulder bolt and flanged nut securing the bellcrank to the control cable bracket. Once loose, remove the bellcrank assembly complete with control link from the unit (Fig. 198).

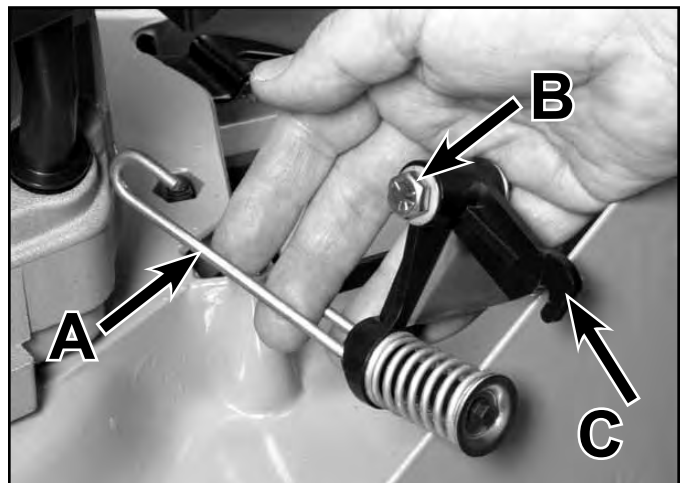

Fig 198

3428-0090

- A. Control link  
B. Shoulder bolt

C. Bellcrank



4. Remove the bushing from inside the bellcrank.
5. Using the control link to hold the control pin, remove the flanged head screw from the control pin (Fig. 199).



Fig 199

3428-0093

**CAUTION!** Always wear safety goggles and gloves when disassembling items under spring tension or compression.

6. Remove the control link from the control pin.
7. Inspect all parts for wear and damage and replace as necessary.

## Bellcrank System Assembly (Toro Vacu Power/Lawn-Boy Medallion)

1. Insert the control pin into the recessed area on the bellcrank.
2. Place the spring onto the control pin. Place the spring retainer onto the spring and insert the screw into the control pin. Using the control link to prevent rotation of the control pin, tighten the flanged head screw until the retainer bottoms out on the control pin (Fig. 199).
3. Note the orientation of the control link in Figure 200. Make sure that it is installed correctly into the bellcrank.

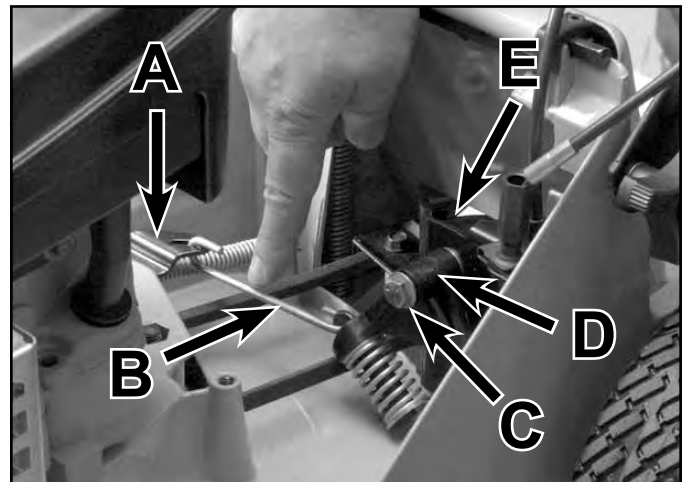

Fig 200

3428-0088

- |                      |                          |
|----------------------|--------------------------|
| A. Brake plate lever | D. Bellcrank             |
| B. Control link      | E. Cable bracket support |
| C. Shoulder bolt     |                          |

4. Slide a flat washer and a bushing onto the shoulder bolt and slide into the front side of the bellcrank as shown in Figure 200. Complete reassembly of the bell crank system by sliding another flat washer onto the carriage bolt.

**Note:** Lubrication of the bushing is not recommended.

# BBC / BOS / BCS

- Hook the end of the control link into the brake plate lever, then slip the BBC control cable onto the bellcrank. Finally, slip the shoulder bolt through the hole in the cable bracket support and secure with the flanged nut.

**Note: The serrations in the flanged nut must fully seat on the control cable bracket.**

- Check the adjustment of the BBC cable as described under "BBC Cable Removal (Recycler/Rear Bagger)" on page 6-19.
- Slide the black plastic transmission cover into place making sure that the belt slides into the grooves provided. Some contact between the belt and the cover may be evident.

**Note: It may be necessary to push the transmission back slightly to get the transmission cover to slide in completely.**

- Place the upper BBC cover into position on the housing and secure with the two self-tapping flanged head capscrews.
- Check for proper operation of all controls, especially the BBC, and adjust as necessary.

**Note: The spring length on the bellcrank assembly is the primary indicator of proper BBC adjustment. It should measure 1" (25mm) with the blade engaged when properly adjusted. If spring measures more than 1-1/4" (32mm), correct by adjusting the BBC control cable.**

## BBC Cover and Screen:

The BBC cover and screen are two important components that keep dirt and debris out of the BBC mechanism. The screen (Fig. 201) is installed, sharp edge down, to allow air to be drawn in through the screen panel on top of the deck and down underneath the deck. This venting improves the airflow underneath the deck thereby improving quality of cut and bagging performance. Be sure to clean the screen on occasion, especially if quality of cut or bagging performance has degraded.

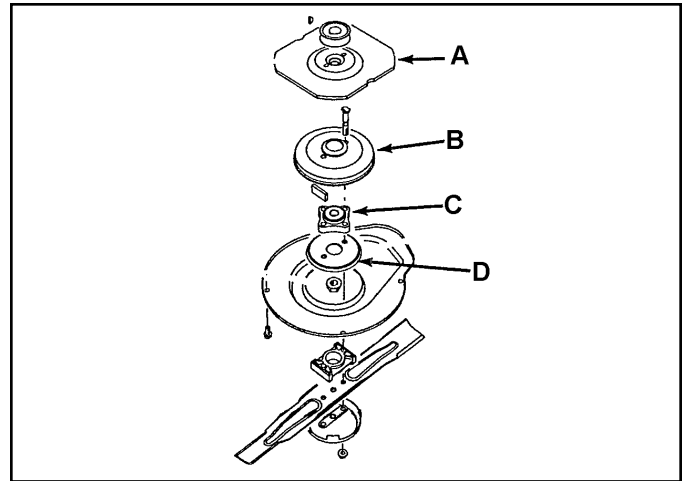

Fig 201

fig. 43

- |                 |                  |
|-----------------|------------------|
| A. BBC flywheel | C. Bearing block |
| B. Brake drum   | D. Screen        |

## Under Deck Components Disassembly (Toro Vacu Power/Lawn-Boy Medallion)

1. Stop the engine and disconnect the spark plug lead to prevent accidental starting. Drain fuel.
2. Remove the 2 flanged nylon locknuts securing the blade to the bearing block and remove the anti-scalp cup, the blade, the blade spacer, and the lower BBC screen (Fig. 202).



Fig 202

3428-0099

3. Remove the 4 flanged head self-tapping screws securing the lower BBC cover to the housing, and remove the lower BBC cover.
4. Before disassembling further, check to make sure that the BBC components are functioning normally. Make sure that the brake and brake drum fully disengage when the control bar is cocked, then raised. Make sure that the BBC flywheel and the brake drum rotate together when the control bar is raised. Make sure that the belt loosens properly when the control bar is lowered. Repair or replace parts as required.

5. If further disassembly is required, begin by removing the crankshaft nut. An impact wrench works best. However, if you must remove it manually, use a large screwdriver or bar to wedge the BBC flywheel while removing the nut (Fig. 203).

**Note:** Be careful not to damage the bearing seal when removing this nut, or premature bearing failure could result.



Fig 203

MVC-724

6. Pivot the brake plate counterclockwise slightly and remove the bearing block and brake drum from the crankshaft (Fig. 204).



Fig 204

MVC-726

7. Again, pivot the brake plate counterclockwise and remove the BBC flywheel.
8. BBC Belt or Idler Pulley Replacement: If the BBC belt or idler pulley requires replacement, it can be done without removal of the brake plate. Remove the idler pulley capscrew and nylon locknut then pull the belt and pulley from the brake plate as an assembly.

**Note: The hubs of the pulley are replaceable, however, the bearing inside the idler pulley is not replaceable separately.**

9. If the brake pad has reached its service life or if the brake plate has been damaged, remove the other capscrew securing the brake plate to the brake plate hub and lever and remove the brake plate assembly. The brake pad is not replaceable separately.
10. If necessary, remove the flanged head capscrew securing the brake lever and hub to the housing.

**CAUTION! The brake plate lever is under moderate spring-loading. Heavy gloves and eye protection are recommended when removing the brake plate lever.**

**Note: Do not use an air wrench on the brake lever self-tapping screw as thread damage to the housing may result.**

11. Remove the brake plate and hub assembly from the housing and disassemble the seal/oil impregnated bushing, the hub, self-tapping capscrew, and washer from the brake lever. Be careful not to lose the plastic bushing which fits on the end of the brake spring rod (Fig. 205).

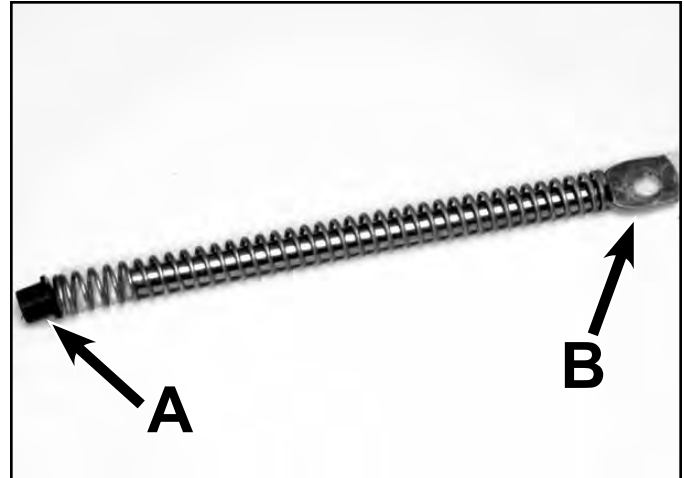

Fig 205

3428-0106

A. Plastic bushing

B. Brake rod

12. Complete disassembly of the brake plate by removing the brake plate screws and the bearing block.
13. Remove the two bearings from the bearing block by pressing the bearings out on an arbor press. Press only on the outer race to prevent bearing damage (use an appropriately sized arbor or a 1-1/8" (28mm) socket).
14. Inspect all parts for damage and/or wear and replace as necessary.

## Under Deck Components Assembly (Toro Vacu Power/Lawn-Boy Medallion)

1. Check to make sure that the brake plate seal is in good condition, then stretch onto the brake plate bushing (Fig. 206).

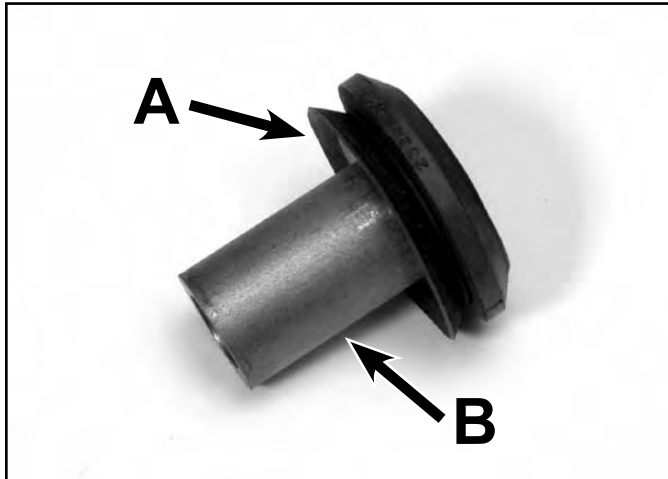

Fig 206

3428-0108

- A. Seal                      B. Brake plate bushing

2. Hook the control link into the slot on the brake lever. Place the spring and bushing onto the brake rod, then slip the bushing and brake rod through the hole provided in the brake lever. Finally, install the bushing hub and flanged head self-tapping screw with the washer through the brake lever.

**Note:** Brake plate capscrew torque: 225 in-lbs. (25.5 Nm)

**Note:** If the self-tapping screw strips the threads in the housing, do not helicoil; rather, place a hex nut in the recess provided in the top side of the deck.

3. Loosely secure the brake plate, complete with brake pad, to the brake lever and brake hub as shown in Figure 207. Note that the bolt should go through the brake plate first. Secure with a nylon locknut but do not tighten at this time. This will allow proper alignment of the idler pulley later.

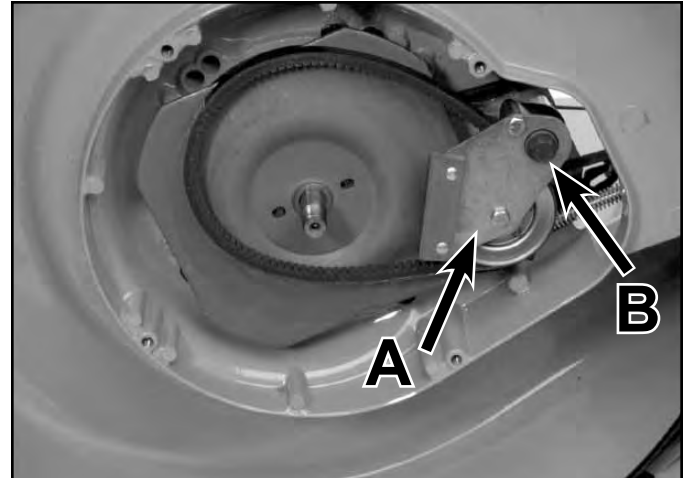

Fig 207

3428-0101

- A. Brake plate                      B. Bolt

4. Install an idler hub into each side of the idler pulley bearing, then slip the belt onto the idler pulley. Slip the entire assembly between the brake plate and brake lever. Secure the carriage bolt and nylon locknut as shown in Figure 207.
5. Tighten the idler pulley bolt. Make sure that the idler pulley spins freely.

**Note:** Idler pulley bolt torque: 100 in-lbs. (11.33 Nm)

# BBC / BOS / BCS

6. Install the BBC flywheel onto the crankshaft, making certain that the slots in the BBC flywheel align with the bumps on the bottom of the self-propel pulley (Fig. 208).

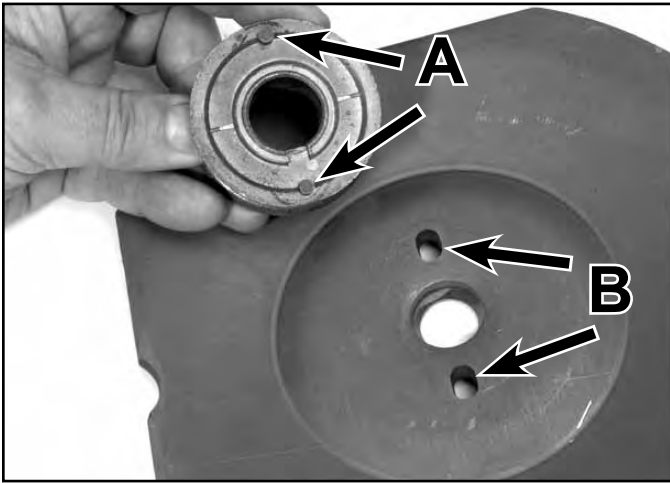

Fig 208

3428-0117

A. Bumps

B. Slots

**Note:** If the crankshaft nut is tightened with these bumps misaligned, the boss at the bottom of the keyway on the self-propel pulley will break and the self-propel pulley will be free to slide up and down on the crankshaft (Fig. 209). This can result in noisy operation, premature belt wear, and belt jumping.

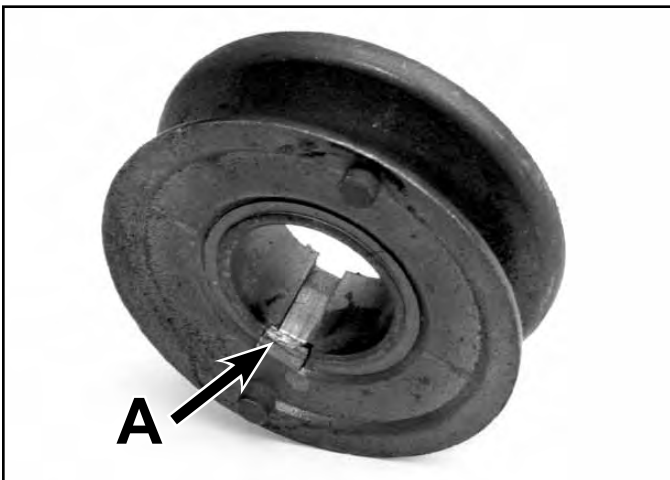

Fig 209

3428-0116

A. Boss

7. Press the bearings into the bearing block, using an arbor press. Press only on the outer race, otherwise bearing damage will result (use an appropriately sized arbor or a 1-1/8" (28mm) socket to press the bearing into the block).
8. Make sure that the foam rubber anti-vibration pads are in place on the brake drum and assemble the brake drum bearing block and BBC screws onto the crankshaft as shown in Figure 210. Secure with the crankshaft nut.

**Note:** Crankshaft nut torque: 45 - 70 ft-lbs. (61 - 95 Nm)



Fig 210

MVC-726

**CAUTION!** As with disassembly, the flywheel can be wedged to tighten the nut. Make sure the bumps in the self-propel pulley stay engaged with the flywheel or the pulley will be damaged.

**Note:** Make sure that the blade bolts are properly aligned before tightening the crankshaft nut.

9. Install the BBC cover with the four flanged head self-tapping screws.
10. Install the BBC screen, the blade spacer, the blade, and the anti-scalp cup onto the BBC screw and secure with the two flanged nylon locknuts. Torque to 300 in-lbs. (37 Nm).

**Note:** Blade locknut torque: 300 in-lbs. (37 Nm)

11. Complete BBC service by checking BBC and self-propel controls, making sure that all are functioning normally. Adjust as necessary.

## BBC Cable Removal (Toro Vacu Power/ Lawn-Boy Medallion)

1. Remove the two flanged head self-tapping screws securing the screen panel to the housing and remove the screen panel as shown in Figure 211.

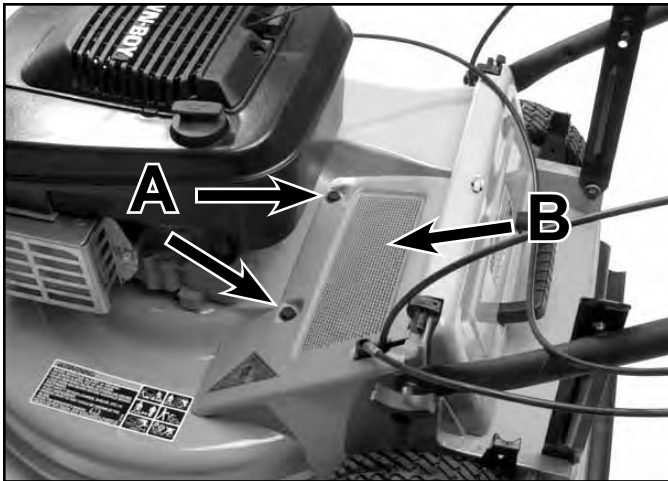

Fig 211

3428-0079

- A. Screws                      B. Screen Panel

2. On early models, the end of the BBC cable sheath has two protruding ears that catch the underside of the cable bracket. Remove the cable by squeezing the ears together, then pulling the cable out vertically. Later models use a clip that must be pushed to the side to remove.

3. Bend the throttle control locking tab back slightly and tap the throttle control from the control panel with a rubber mallet. Place a piece of duct tape over the heads of the handle and the BBC control box. This will prevent the control box components from falling out of the handle during disassembly.
4. Remove the three flanged head screws securing the control box halves.
5. Remove the two nylon locknuts securing the control box to the handle and carefully remove the right control housing half.
6. Slip the end of the BBC cable from the cable lever and remove the cable (Fig. 212).

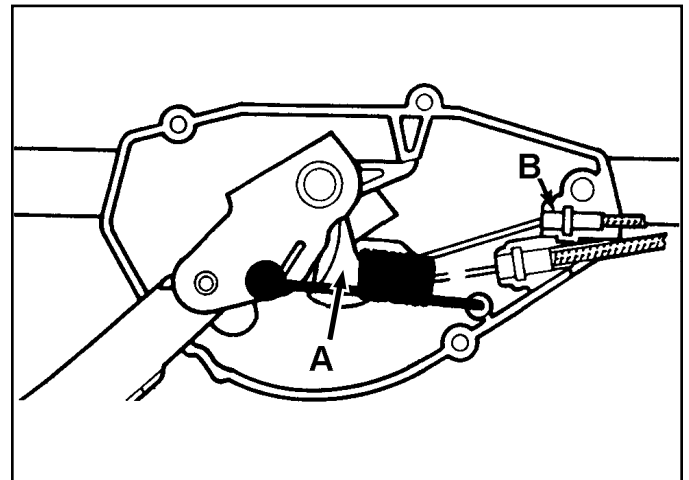

Fig 212

fig 36

- A. BBC cable lever              B. BBC cable

# BBC / BOS / BCS

## BBC Cable Installation (Toro Vacu Power/Lawn-Boy Medallion)

1. Slide a new BBC cable into the BBC cable lever. Then install the end of the cable sheath in the recess provided in the left control housing half (Fig. 213).

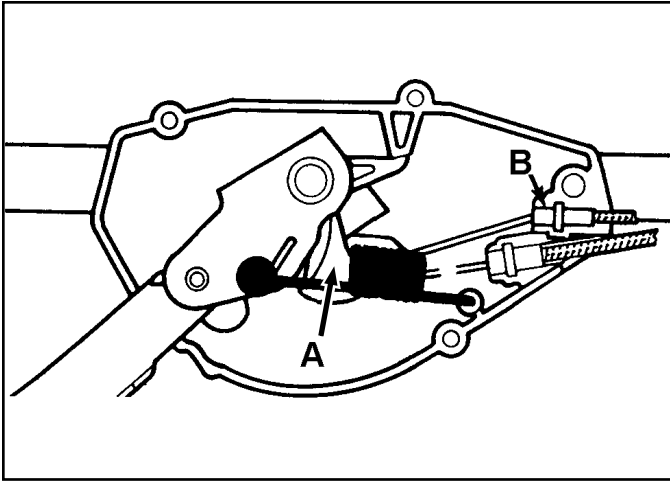

Fig 213

fig 36

- A. BBC cable lever      B. BBC cable

2. Before installing the right control housing half, make sure that the traction and BBC ends are completely seated in their recesses. Also make sure that the sleeve on the upper carriage bolt passes completely through the BBC control box components to the handle. Finally, make sure that the roll pin in the rocker arm passes through the hole in the control bar. Install the right control housing half. Secure with two nylon locknuts.

**Note:** The flanged locknut fits on the upper carriage bolt.

3. Install the three flanged head screws securing the control box halves.
4. Bend the throttle control locking tab forward so that it will provide positive engagement with the throttle control. Install the throttle control.
5. Hook the lower end of the BBC cable onto the bell-crank. Slip the cable through the slot in the cable bracket. Push the end of the cable sheath into the cable support bracket as shown in Figure 214.

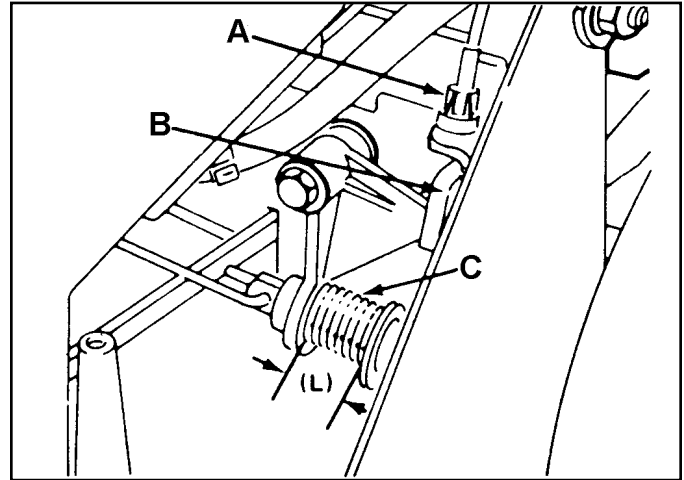

Fig 214

fig 68

- A. Plastic fitting      C. Spring  
B. Cable fitting

6. Before installing the screen panel, adjust the BBC cable as described under "BBC Cable Adjustment (Toro Vacu Power/Lawn-Boy Medallion Models)", which follows. See page 7-15.



## ENGINE AND BLADE ASSEMBLY (Toro Recycler / Rear Bagger)

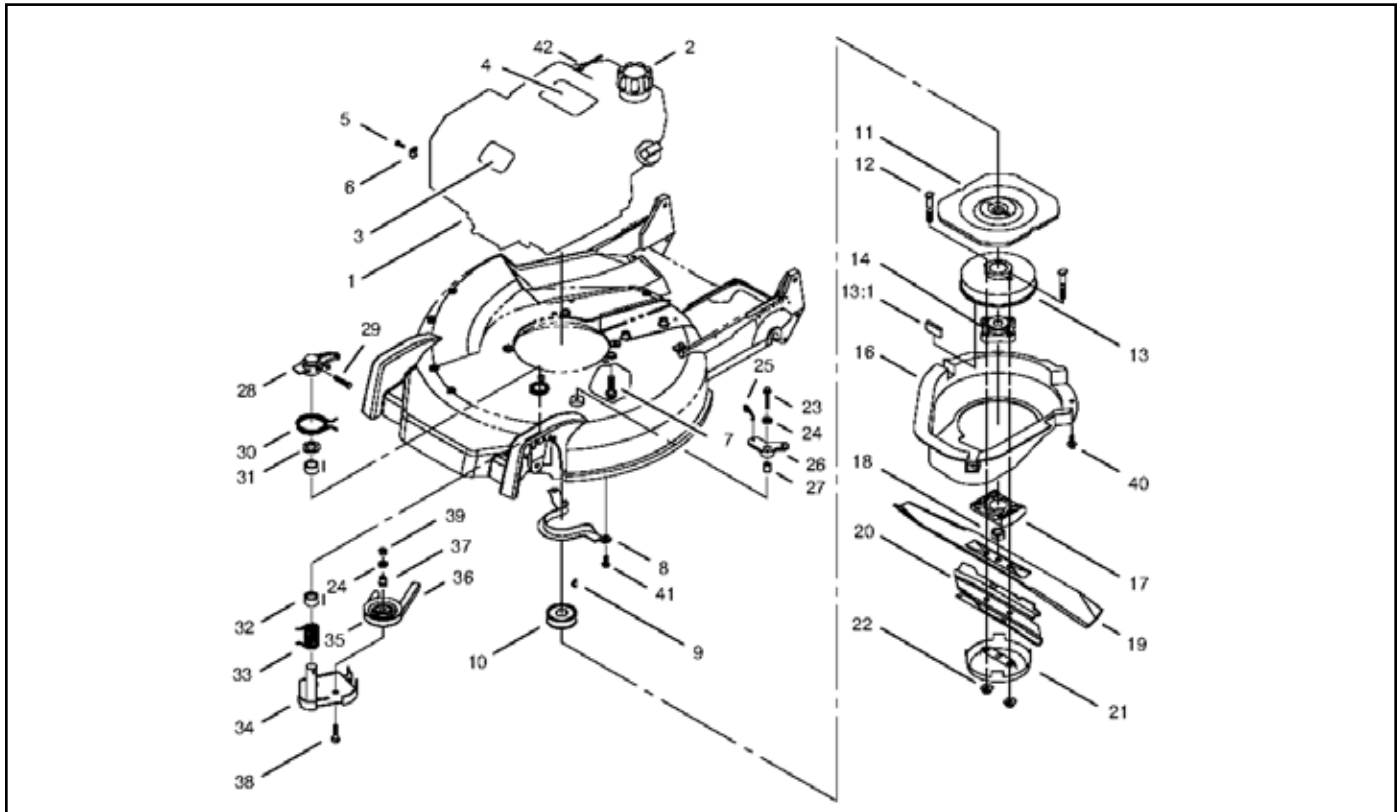

Fig 215 engine and blade assy

Ref. No.	Qty	Description
1	1	Gts Ohv 200 Engine
2	1	Gas Cap ASM
3	1	Toro Nameplate
4	1	Recoil Decal
5	1	Clamp Screw
6	1	Casing Clamp
7	3	HWH Screw
8	1	Belt Guide Bracket
9	1	Woodruff Key
10	1	Pulley
11	1	Flywheel
12	2	Blade Bolt
13	1	Brake Drum ASM
13:1	2	Vibration Dampener
14	1	Hub ASM
16	1	Shield
17	1	Blade Spacer
18	1	Blade Nut
19	1	Recycler Blade
20	1	Blade Stiffener
21	1	Anti-Scalp Cup

Ref. No.	Qty	Description
22	2	Lock Nut
23	1	HH Screw
24	2	Flat Washer
25	1	Control Link
26	1	Bellcrank
27	1	Bellcrank Sleeve
28	1	Lever
29	1	HH Screw
30	1	Torsion Spring
31	1	Washer
32	2	Bearing
33	1	Torsion Spring
34	1	Brake ASM
35	1	Idler Pulley
36	1	V Belt
37	1	Idler Hub Pulley
38	1	HH Screw
39	2	NI Lock Nut
40	3	HWH Screw
41	2	HH Screw
42	1	Rope Stop

## TORO RECYCLER/REAR BAGGER BBC



Fig 216

1350-001 a

### Idler Arm System Disassembly (Recycler/ Rear Bagger)

1. Drain the fuel and oil. Remove the spark plug wire. Disassembly for the idler arm begins on top of the mower housing.

2. On the left side of the mower next to the rear wheel, loosen the clamp that secures the BBC cable to the mower housing. Near the left front wheel, unhook the spring end of the cable from the bellcrank. Remove the screw, bellcrank, sleeve, and unhook the control link from the lever (Fig. 217).



Fig 217

3428-0174

3. Take a loop of wire or rope and unhook the spring under the lever (Fig. 218). With the tension removed you can now remove the long screw through the lever. We would suggest loosening this screw, but leave it engaged at this time (Fig. 220).

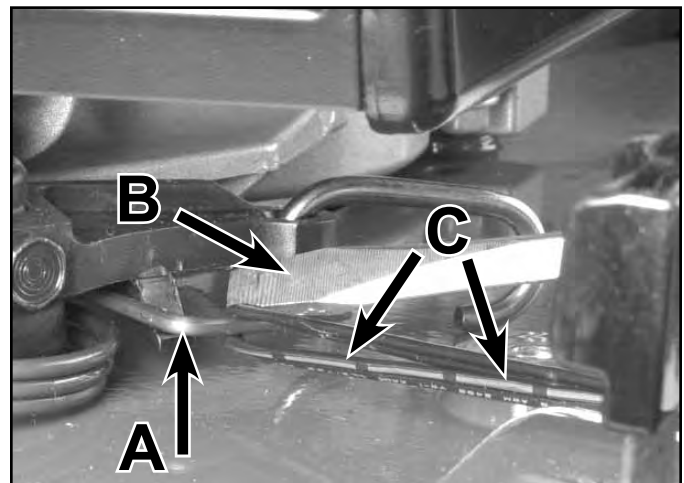

Fig 218

3428-0177-2

- A. Spring  
B. Screwdriver

- C. Wire loop

4. Turn the mower on its side. Remove the blade and the BBC cover. Brush any grass clippings out of the area. Locate the idler arm. Remove the bolt and locknut that retains the idler pulley. Note the pulley is on the deck side and there is a spacer between the pulley and idler arm (Fig. 219). With the pulley removed, the idler arm can pivot away from the brake drum and the belt can be removed.



Fig 219

3428-0182

Slide the lever off the shaft and the idler/brake shaft can be pulled down and out of the housing (Fig. 221).



Fig 221

3428-0192

There are two bearings pressed into the housing that the idler shaft rides on. If they are to be replaced, press them out at this time (Fig. 222).

5. Now reach around to the top of the housing and pull the screw out of the lever (Fig. 220).



Fig 220

3428-0179

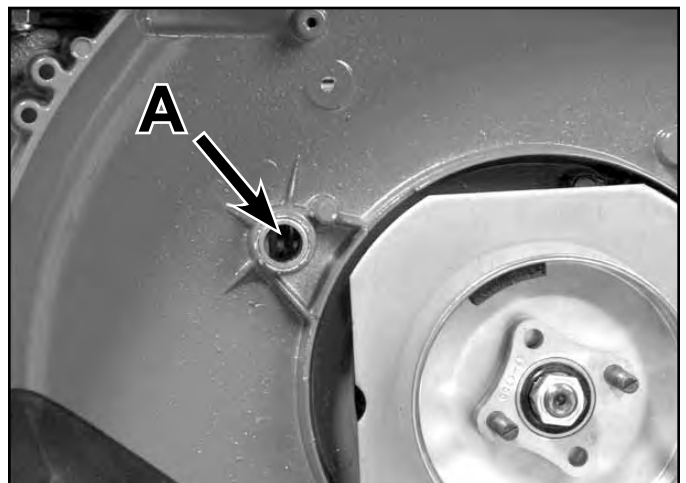

Fig 222

3428-0185

A. Bearings

# BBC / BOS / BCS

6. Now, disassemble the components on the crankshaft. If you have an impact wrench, the large nut on the crankshaft can be spun off. If you must remove it manually, wedge a bar or large screwdriver into the BBC flywheel (Fig. 223). This will hold the crankshaft so the nut can be removed.



Fig 223

3428-0187

7. Remove the hub assembly and brake drum. The flywheel is pressed onto a taper on the crankshaft. It might require a tap with a hammer to loosen (Fig. 224).



Fig 224

3428-0103

8. Roll the self-propel belt off the pulley and remove the pulley and the key in the crankshaft.

9. Inspect the pulley. One end of the keyway is blocked off. If that is broken, the pulley will bounce up and down during use and make a rattling noise (Fig. 225). There are two bumps on the outside of the pulley that are intended to engage two holes in the flywheel. If this wall is broken out or the bumps on the pulley are damaged, the pulley must be replaced. Usually this is caused by an error in assembly. Refer to "Idler Arm System Assembly (Recycler/Rear Bagger)" on page 6-25 for instructions to avoid this.

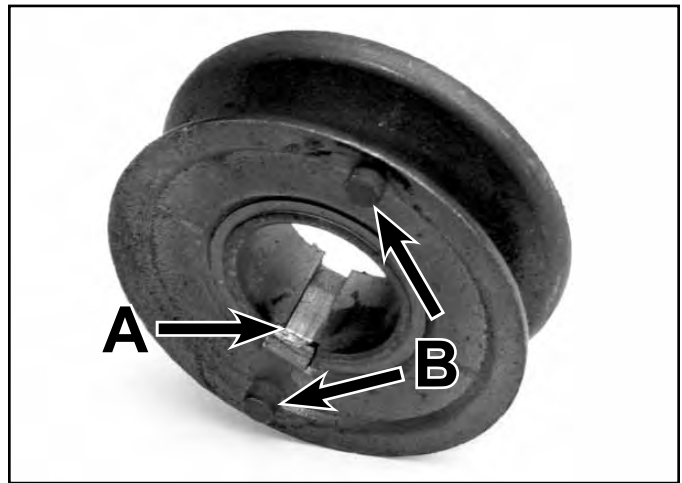

Fig 225

3428-0116

A. Wall

B. Bumps

## Idler Arm System Assembly (Recycler/Rear Bagger)

1. Start by installing the key and self-propel pulley. The two bumps on the pulley should face you (Fig. 226). Slip the belt over the pulley.

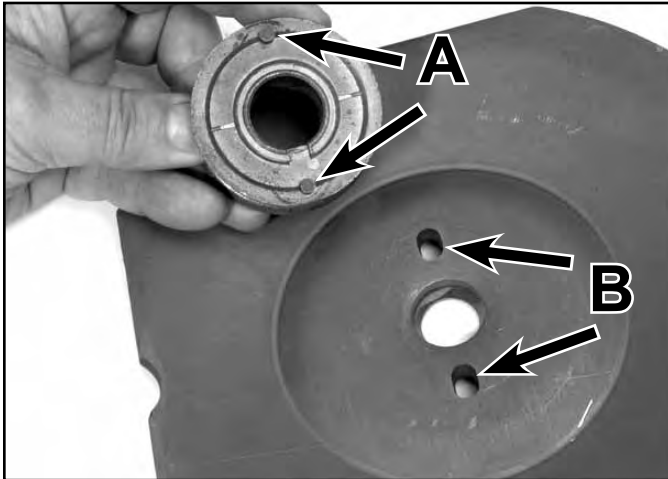

Fig 226

3428-0117

- A. Bumps                      B. Holes in flywheel

2. Install the flywheel. The two bumps on the pulley **MUST** engage the holes in the flywheel. If not, when the nut on the crankshaft is tightened, the flywheel will push the pulley upwards, either breaking the wall out of the key groove or crushing the two bumps or both.

The flywheel must be installed with the side that looks like 1/2 of a pulley facing the brake drum (Fig. 227). Push the flywheel firmly on the taper of the crankshaft. If you can't push the flywheel on far enough to hold, do not be concerned. **DO NOT** drive it on with a hammer.



Fig 227

MVC-727

3. Note the two small foam pads inside the brake drum (Fig. 228).

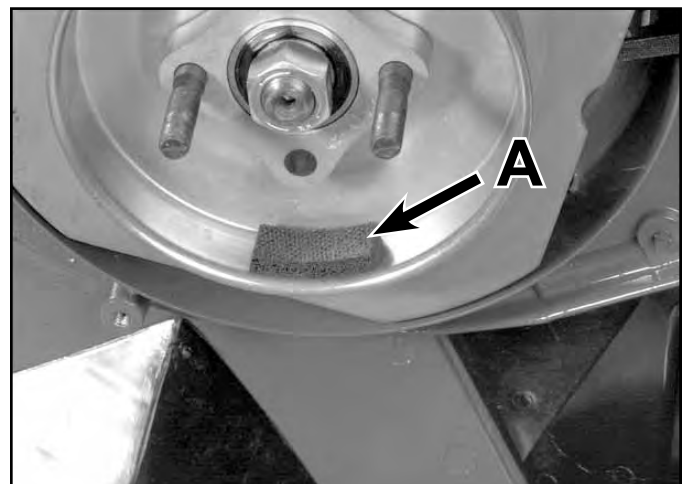

Fig 228

3428-0188

- A. Foam pad

# BBC / BOS / BCS

They are noise dampeners. Without them, when the brake pad hits the drum, the drum will ring like a bell. Also look at the two blade mounting bolts. Each has a flat side on the head to prevent them from rotating when the nut is tightened (Fig. 229). Make sure the bolts are fully seated. Install the brake drum.



Fig 229

3428-0189

**CAUTION!** The two bumps on the pulley **MUST** engage the flywheel. If you do not have an impact wrench, this is where the two bumps become important. If you engage the bumps on the pulley into the flywheel, you can now wedge the flywheel and through the pulley and key, it will hold the crankshaft from rotating while you tighten the nut (Fig. 230).

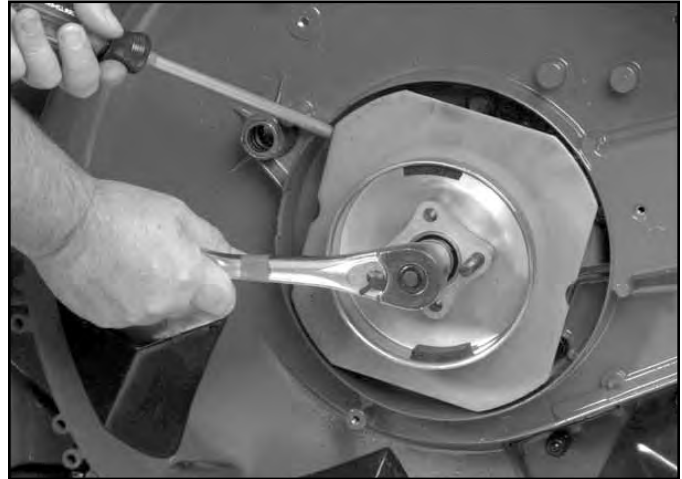

Fig 230

3428-0187

4. Inspect the hub assembly if the old one is to be reused. Rust on the outside is harmless. But the seals in the bearing need to be intact. If the seals are damaged or the bearing feels rough when it is turned, replace the hub assembly.
5. Start the nut on the crankshaft. As during disassembly, an impact wrench works best.

6. Slip the BBC belt over the parts on the crankshaft.
7. Check the shaft of the idler/brake arm. Clean as necessary and apply a light coat of grease.

8. Slip the spring over the shaft. One tang of the spring must engage the tab as shown (Fig. 231).



**Fig 231** 3428-0190

A. Idler/brake arm

9. Start the shaft into the hole in the housing. Rotate the idler/brake arm clockwise so the upper tab on the spring can engage the boss in the housing. Rotate the idler/spring arm counterclockwise (Fig. 232) and push the rest of the way into the housing. The brake pad should now ride on the brake drum.



**Fig 232** 3428-0192

10. Hold the idler/brake arm in place. Slip the spring over the end on top of the deck as shown. Install the lever and install the screw through the lever and idler/brake arm shaft (Fig. 233). Once the screw is secured take a loop of wire or rope and hook the end of the spring. Pull it towards you and hook the end as shown.

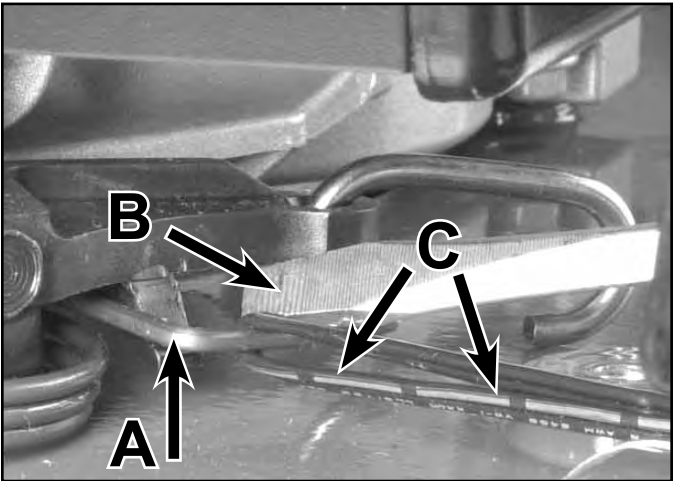

**Fig 233** 3428-0177-3

A. Spring  
B. Screwdriver  
C. Wire loop

# BBC / BOS / BCS

## BBC Cable Removal (Recycler/Rear Bagger)

1. Loosen the cable clamp and pull cable out from under the screw (Fig. 234).



Fig 234

3428-0172

2. Unhook the spring and cable from the bellcrank (Fig. 235).



Fig 235

3428-0173

3. Bend the throttle control locking tab back slightly and tap the throttle control from the control panel with a rubber mallet. Place a piece of duct tape over the heads of the handle and the BBC control box mounting bolts. This will prevent control box components from falling out of the handle during disassembly.
4. Remove the three flanged head screws securing the control box halves.
5. Remove the two nylon locknuts securing the control box to the handle and carefully remove the right control housing half.
6. Slip the end of the BBC cable from the cable lever and remove the cable (Fig. 236).

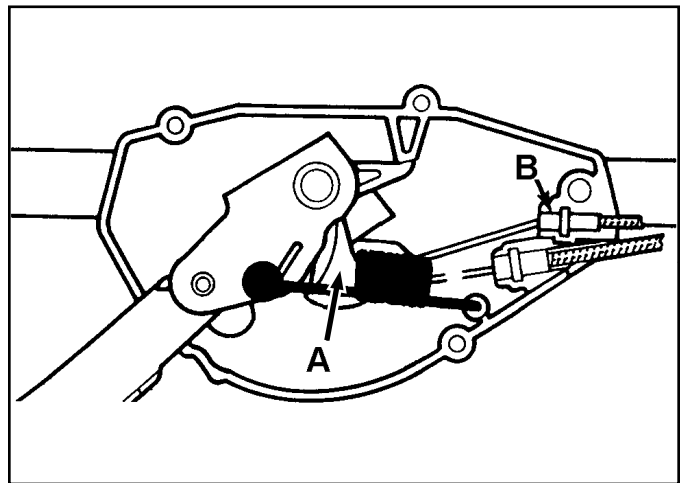

Fig 236

fig 36

- A. BBC cable lever      B. BBC cable



## BBC Cable Installation (Recycler/Rear Bagger)

1. Slide a new BBC cable into the BBC cable lever. Install the end of the cable sheath in recess provided in the left control housing half.
2. Before installing the right control housing half, make sure that the traction and BBC ends are completely seated in their recesses. Also make sure that the sleeve on the upper carriage bolt passes completely through the BBC control box components to the handle. Finally, make sure that the roll pin in the rocker arm passes through the hole in the control bar. Install the right control housing half. Secure with two nylon locknuts.

**Note: The flanged locknut fits on the upper carriage bolt.**

3. Install the three flanged head screws securing the control box halves.
4. Bend the throttle control locking tab forward so that it will provide positive engagement with the throttle control. Install the throttle control.
5. Hook the spring on the end of cable and into the bellcrank arm (Fig. 237).



Fig 237

3428-0173

6. Slip end of cable under screw. See page 7-16.

## BLADE OVERRIDE SYSTEM (BOS) BLADE CLUTCH SYSTEM (BCS)

Both Toro and Lawn-Boy use the same blade clutching system on some models. On Toro it is named the Blade Override System. On Lawn-Boy it is named the Blade Clutch System.

It is designed to allow the blade to stop while the engine keeps running. This is especially helpful when bagging, as the engine will not need to be restarted each time you stop to empty the bag.

### Disassembly

The following steps are disassembly of the system, including the steps necessary to replace the blade drive and self-propel belts.

1. Drain the fuel and oil and tip the mower on its side. We recommend carburetor side up to prevent any oil or gasoline from draining into the air filter and causing hard starting.
2. Remove the two locknuts securing the blade (Fig. 238).



Fig 238

MVC-195X

# BBC / BOS / BCS

3. Remove the blade and blade stiffener (Fig. 239).



Fig 239

MVC-197X

5. Remove the 3 capscrews and lift off the belt cover (Fig. 241).



Fig 241

MVC-199X

4. Remove the blade support and disc (Fig. 240).



Fig 240

MVC-198X

6. Remove the brake pivot bolt. You will need a second wrench to hold the bolt head (Fig. 242).

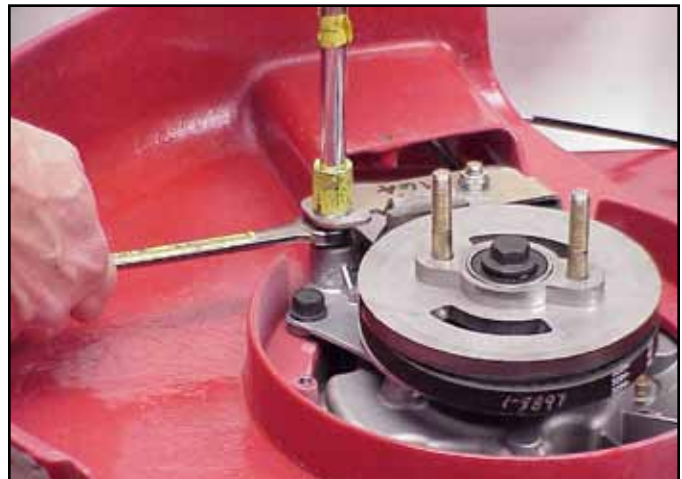

Fig 242

MVC-200X

7. Unhook both springs from the slot in the brake arm (Fig. 243).



**Fig 243** MVC-203X

9. To replace the blade drive belt, remove the idler pulley bolt (Fig. 245).



**Fig 245** MVC-207Xa

8. Lift the brake assembly and blade drive belt from the mower (Fig. 244).



**Fig 244** MVC-205X

10. The components of the idler assembly are shown here (Fig. 246).

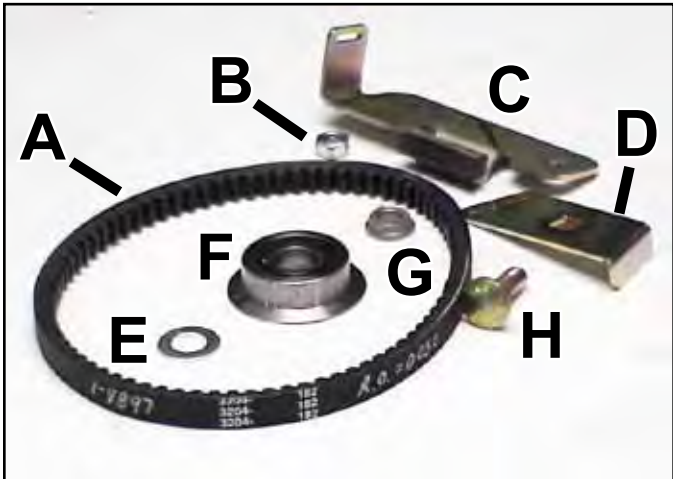

**Fig 246** MVC-209Xa

- A. Belt
- B. Nut
- C. Brake arm
- D. Belt guard
- E. Washer
- F. Bearing with flange
- G. Spacer
- H. Bolt

# BBC / BOS / BCS

11. Continuing with the disassembly, remove the bolt securing the pulley to the crankshaft.

**Note:** Use a large screwdriver or pry bar to keep the pulley from turning while you unscrew the bolt (Fig. 247).

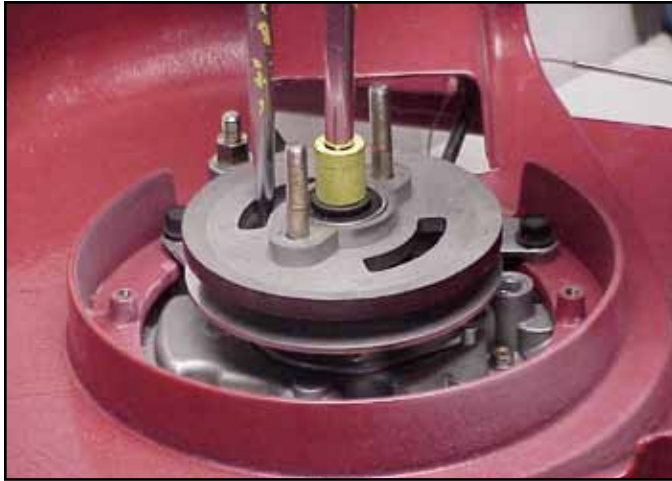

Fig 247

MVC-218X

13. Lift the crankshaft pulley half off of the crankshaft. Note this pulley half is keyed to the crankshaft and this pulley half is also the drive pulley for the self-propel belt. Go to the transmission to continue replacing the self-propel belt (Fig. 249).



Fig 249

MVC-222X

12. Rock the pulley half slightly and lift it off. The blade bolts will now drop out of their pockets (Fig. 248).



Fig 248

MVC-220X

14. Remove the two bolts holding the anchor plate to the chassis (Fig. 250).



Fig 250

MVC-223X

15. The anchor plate contains a pivot screw with a bushing. Remove the locknut (Fig. 251).



**Fig 251** MVC-224Xa

16. The bushing has a notch removed from the flange end. Align that notch in the bushing with the tab in the anchor plate (Fig. 252).

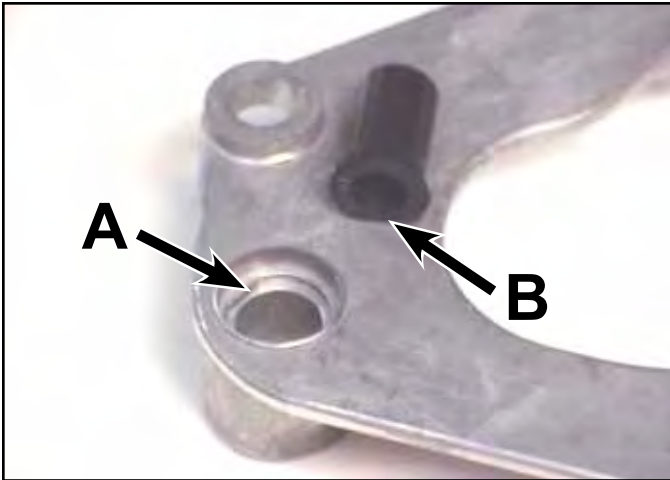
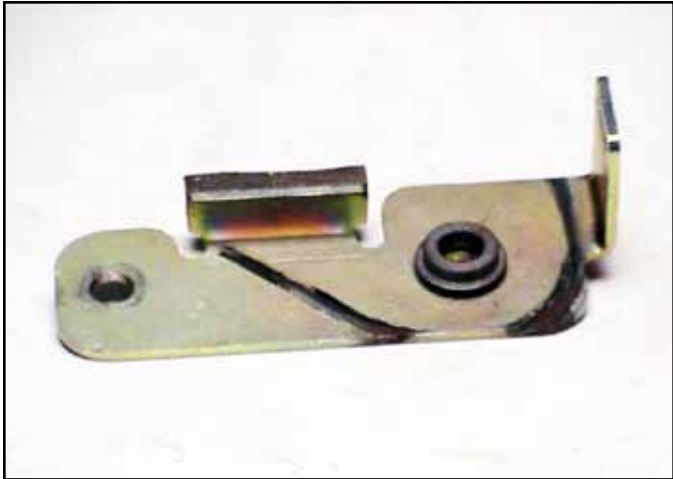

**Fig 252** MVC-257X

A. Tab                      B. Notch

**Brake Arm Assembly**

1. Place the spacer with the large diameter down on the brake arm (Fig. 253).



**Fig 253** MVC-211Xa

2. Place the bearing with the flange side down on the spacer and place the washer on top of the bearing (Fig. 254).



**Fig 254** MVC-213Xa

3. Install the belt, belt guide, and carriage bolt on the brake arm and secure with the carriage bolt (Fig. 255).



Fig 255

MVC-216Xa

## BOS/BCS System Assembly

Assemble all other parts in reverse order.

**Bolt torque as follows:**

**Blade nuts: 350 - 400 in-lbs. (39.5 – 45.2 Nm)**

**Crankshaft Bolt: 45 - 55 ft-lbs. (60.9 – 74.5 Nm)**

# HANGLES & CONTROL CABLES

---

Safety Information . . . . .	1
Worm Drive Transmission . . . . .	2
Single Speed Spur/Bevel Gear Transmission . . . . .	3
Single Speed Bevel Gear Transmission . . . . .	4
Three Speed Transmission . . . . .	5
General Transmissions® . . . . .	6
Wheel Pinion Clutch . . . . .	7
Blade Brake Clutch Systems (BBC), Blade Override System (BOS), Blade Clutch Systems (BCS) . . . . .	8
<b>Handles and Control Cables . . . . .</b>	<b>9</b>
Self-Propel Belt Replacement . . . . .	10

# HANDLES & CONTROL CABLES

There are four types of handle and control assemblies on mowers not covered in other parts of this manual. This section will cover disassembly and repair of those types.

## Toro 2 Bail Handle



Fig 256

3428-0049

A. Self-propel cable adjuster

The 2 bail style is shown here. The top bail is the engine kill. Release it and the ignition is grounded and a brake comes on to help stop the flywheel. The lower bail is the self-propel bail. Squeeze it to tension the belt and drive the transmission. It should be adjusted so that lowering the bail about 1" (25mm) disengages the self-propel.

Handle disassembly is self explanatory so we will not discuss that.

The engine stop cable is not adjustable. If it fails to function, it must be replaced.

The self-propel cable is adjustable through a clamp which is typically located a few inches down the handle. Loosen this clamp and push the cable jacket up or down to adjust. When the bail is lowered about 1" (25mm) the drive should disengage. This is a gap that is comfortable for most operators.

Some models used a knob to adjust the self-propel cable (Fig. 257).

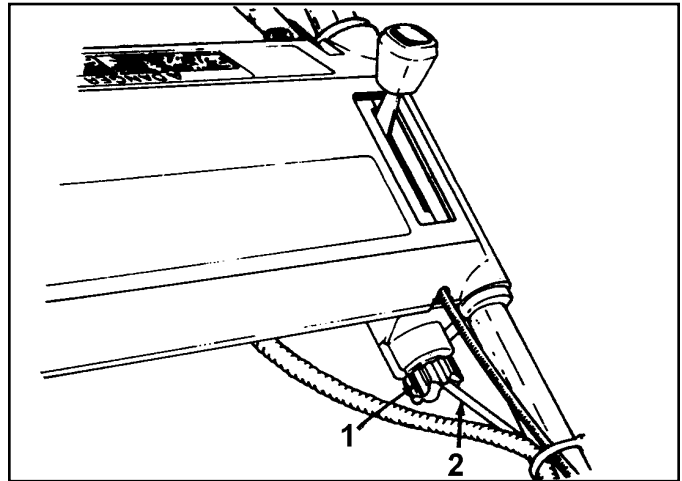

Fig 257

fig 19

1. Knob
2. Cable

Turning the knob tightens or loosens the cable. When the bail is lowered about 1" (25mm) the drive should disengage.



# HANDLES & CONTROL CABLES

## Personal Pace Generation 1/Easy Stride Generation 1

This is the original Toro Personal Pace/ Lawn Boy Easy Stride system. The handle is telescoping and as it slides, it tensions the transmission drive belt.

### Operation

The best way to use this system is as follows: Hold your elbows at your sides and your hands straight out in front of you and just walk. If you want to go faster, walk faster. The key is keeping your elbows at your sides. This applies the right amount of pressure to the handle to engage the drive. If you just push the handle down it will engage too rapidly and the mower will jump forward.

### Disassembly



Fig 258

DSC-4801a

1. Squeeze the ends of the control bail to disengage it from the handle. Disconnect the cable from the bail and set aside (Fig. 259).



Fig 259

DSC-4804a

2. Turn the handle over and remove the cable clamp, screw and the cable from the pocket (Fig. 260).



Fig 260

DSC-4808a

# HANDLES & CONTROL CABLES

3. Remove 6 screws from the traction rod retainer (Fig. 261).



Fig 261

DSC-4810a

5. Disconnect the cable from the traction lever (Fig. 263).



Fig 263

DSC-4815a

4. Remove the traction rod retainer. Note the location of the traction control rod (Fig. 262).



Fig 262

DSC-4811a

6. Unhook the springs from each side of the handle (Fig. 264).



Fig 264

DSC-4814a

# HANDLES & CONTROL CABLES

7. Slide the handle up and off (Fig. 265).



Fig 265

DSC-4819a

8. If you need to replace the traction control rod or either of the springs, one of the handle guides will need to be removed. The guides are held on by 2 screws (Fig. 266).



Fig 266

DSC-4821a

## Reassembly

Reassemble in reverse order.

1. There are 3 bosses on the inside of the guide. The top and bottom ones receive the mounting screws. The boss in the photo must line up with the end of the control rod. This boss keeps the rod from moving sideways and falling out of the handle (Fig. 267).

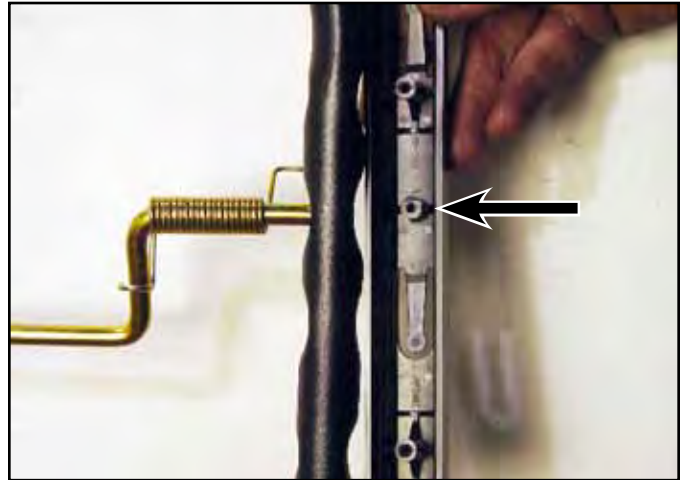

Fig 267

DSC-4828a

2. One end of the springs goes into a hole in the handle, the other around the traction control rod. The springs apply pressure to the handle to hold it in the retracted, upper position (Fig. 268).



Fig 268

DSC-4814a

# HANDLES & CONTROL CABLES

## Adjusting the Personal Pace Cable

Ensure the transmission belt is disengaged, transmission tilted forward. Loosen the cable clamp on the handle. When you pull the cable down the personal pace handle should raise to the stop. Hold the cable and secure the clamp (Fig. 269).



Fig 269

DSC-4829a

## Personal Pace Generation 2/Easy Stride Generation 2



Fig 270 tco\_s\_wpm\_20018\_handle

This is the second generation of the Personal Pace/Easy Stride handle assembly. It works the same as the original in the sense that the handle is telescoping. As the handle is depressed it tightens the self-propel belt and drives the transmission.

## Disassembly

To ease removal of the Personal Pace handle from a 22" Recycler, make a tool from a piece of metal strapping or banding material. You will need two pieces about 5" (12.7cm) long each. Bend them as shown in the photo and round the ends to remove burrs. This tool permits the handle to slide up and over the internal handle stops (Fig. 271).



Fig 271

MVC-712Xa

1. Disconnect the control cables and the key switch (electric start models) from the upper handle and Personal Pace handle. Separate the upper and lower handle. Remove the brake bail by pressing the two ends together until they come out of the holes in the handle.

# HANDLES & CONTROL CABLES

2. Install the tool over the stop in the handle guides as shown, one on each side. Push the handle down. The tool will allow the handle to slide over the stop built into the handle guide (Fig. 272).



Fig 272

MVC-005Xa

3. As the handle begins to slide downward, pull the traction control bar farther out of the handle (Fig. 273).

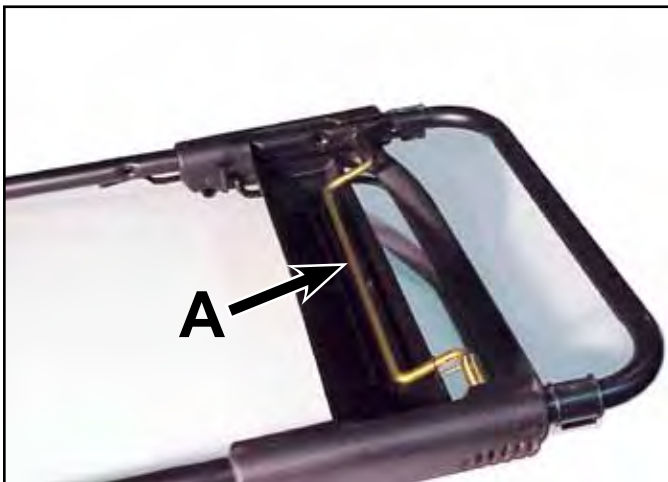

Fig 273

MVC-707Xa

A. Traction Control Bar

4. Continue pushing the handle down until it slides off the end of the upper handle (Fig. 274).



Fig 274

MVC-709Xa

5. When reinstalling the handle, reconnect the spring as shown. The spring should push the handle upwards toward the disengage position (Fig. 275).

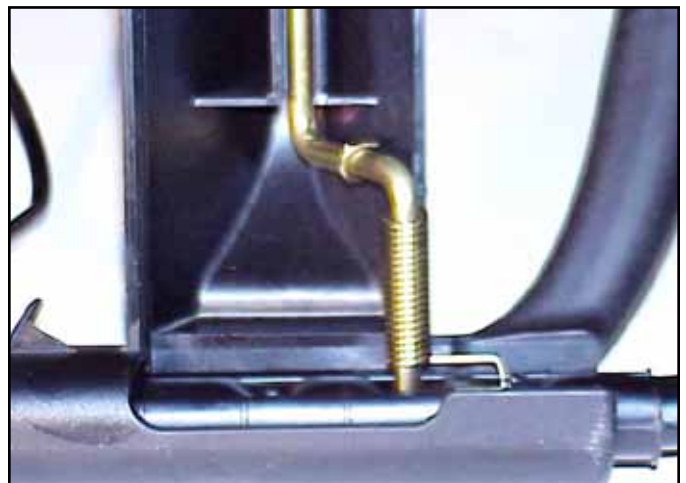

Fig 275

MVC-710Xa

# HANDLES & CONTROL CABLES

## Adjusting the Personal Pace/Easy Stride Cable

Ensure the transmission belt is disengaged, transmission tilted forward. Loosen the cable clamp on the handle. When you pull the cable down the Personal Pace/Easy Stride handle should raise to the stop. Hold the cable and secure the clamp (Fig. 276).



Fig 276

DSC-4829a

## Lawn-Boy 2 Bail Handle

The 2 bail style is shown here (Fig. 277). The top bail is the engine stop. Release it and the ignition is grounded and a brake comes on to help stop the flywheel. The lower bail is the self-propel bail. Squeeze it to tension the belt and drive the transmission.



Fig 277

3428-0049

The engine stop cable is not adjustable. If it does not function, it must be replaced.

The self-propel cable is adjustable through a clamp. It should be adjusted so that lowering the bail about 1" (25mm) disengages the self-propel. This is a gap that is comfortable for most operators.

# HANDLES & CONTROL CABLES

## Lawn-Boy Sens-a-Speed

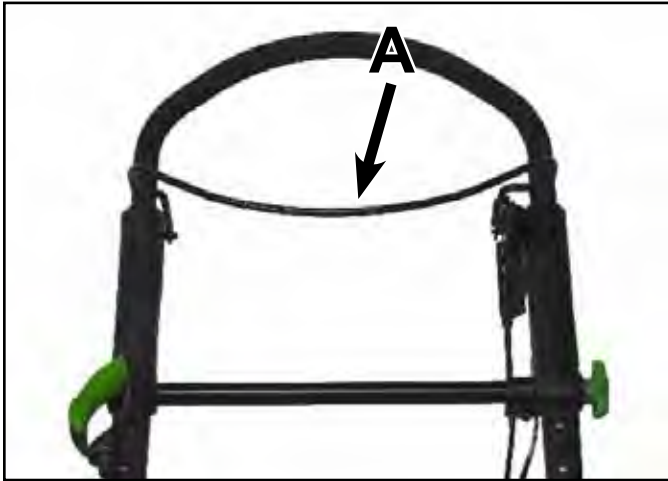

Fig 278

DSC-4864a

A. Top bail

The Lawn-Boy Sens-a-Speed handle is made in two forms, zone start and blade clutch. The basic function is the same but the addition of the blade clutch mechanism makes the handle for those models a little more complex.

### Operation

The top mounted bail is the engine stop control on zone start models and the blade control on blade clutch models.

On a zone start model, pull the top bail down and hold to keep the engine running. The Sens-a-Speed handle telescopes and as it is depressed tensions the transmission drive belt. To operate this keep your elbows at your sides, hold your hands straight out in front of you and walk. If you want to go faster, walk faster. Do not push the Sens-a-Speed handle down. That will activate the drive too aggressively and the mower will jump forward.

On blade clutch models, the engine on and off is controlled by a switch on the left hand handle. The bail engages and disengages the blade. The Sens-a-Speed handle controls the self-propel the same way as on a zone start model.

### Handle Disassembly, Zone Start Models

1. Loosen the cable clamp and disconnect the Sens-a-Speed cable (Fig. 279).



Fig 279

DSC-4869a

2. Squeeze the ends of the upper bail to disengage them from the handle. On some models the right side of the bail may be connected to the pin by a push nut. The push nut can be removed or the bail removed with the pin attached (Fig. 280).



Fig 280

DSC-4871a

# HANDLES & CONTROL CABLES

---

3. Remove the shoulder bolt and the traction lever (Fig. 281).



Fig 281

DSC-4880a

4. Slide the pin out of the left hand handle and pull the upper handle up and out.
5. The plastic sleeves will slide off the upper handle.
6. The springs can be removed from the top slides if necessary.

## Assembly

If the handle has been binding, clean the top slides and the sleeves before assembling. Dirt and grit in the sliding part of the handle can cause a bind.

Assemble in reverse order. When you install the upper handle, line up the holes and install the pivot pins (Fig. 282).



Fig 282

DSC-4885a



# HANDLES & CONTROL CABLES

## Cable Adjustment

The engine brake cable is not adjustable. If it fails to function it will need to be replaced.

## Self-Propel Cable

To properly adjust the self-propel cable, loosen the cable clamp, pull the cable downward to remove all the slack (Fig. 283) then push the cable jacket up 1/8" (3.17cm) (Fig. 284) and secure with the cable clamp.

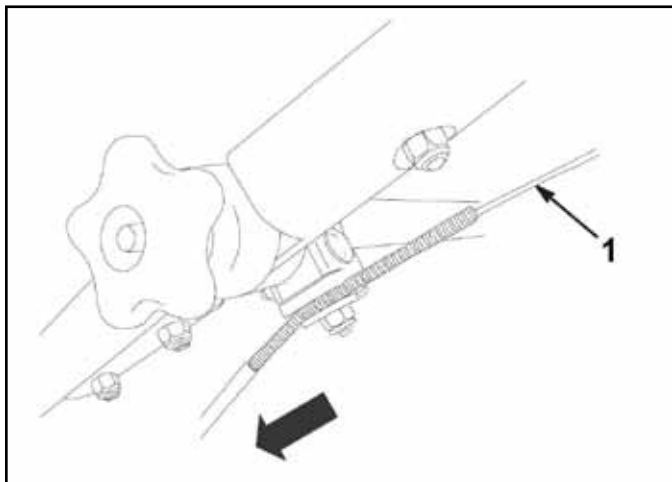

Fig 283

G002635\_a

1. Cable

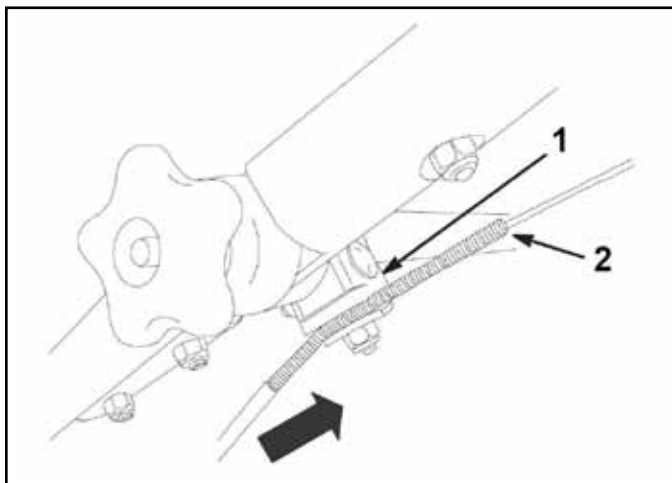

Fig 284

G002634\_a

1. Cable clamp
2. Cable

## Handle Disassembly, Lawn-Boy Blade Clutch System (BCS) Models

1. Remove the upper wire bail. On the right hand side it slides over a pin. On some models this pin has a push nut on it (Fig. 285). It can be compressed so that either the bail slides off the pin or it draws the pin out of the handle. Either is acceptable.



Fig 285

DSC-4871a

2. Remove the e-clip on the left side pivot pin (Fig. 286).

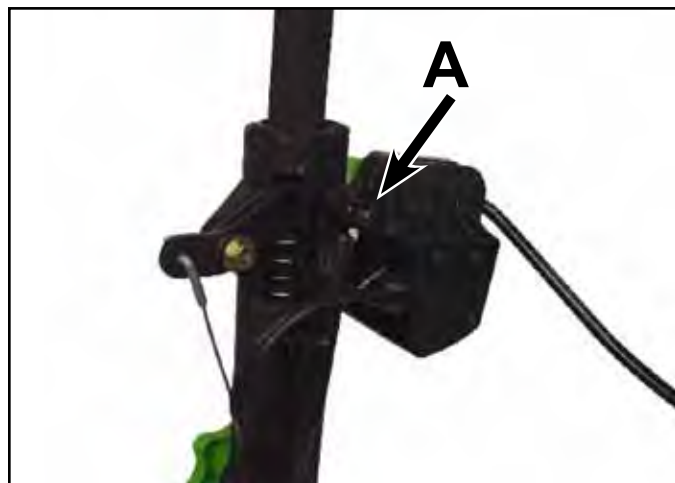

Fig 286

DSC-4896a

- A. E-clip

# HANDLES & CONTROL CABLES

- Slide the pivot assembly, bail and the brake cable to the right until the bail slides off the pin (Fig. 287).

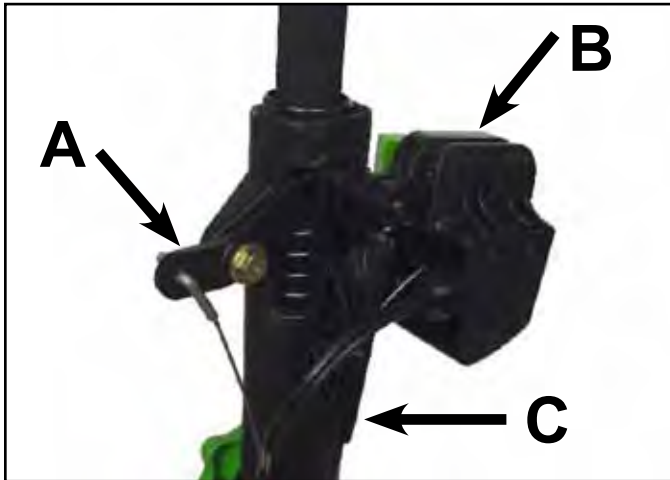

Fig 287

DSC-4899a

- A. Traction lever
- B. Pivot assembly
- C. Top slide

- Continue sliding the pivot assembly and brake cable off the pin.
- Remove the shoulder bolt that the traction lever pivots on and remove the traction lever.
- Pull the pin out of the left hand handle. Note it is snapped in and will require a locking pliers or something similar to remove. When removed, the springs will push the handle upwards (Fig. 288).



Fig 288

DSC-4907a

- Slide the upper handle out of the top slide.

Reverse the process to assemble.

Note how the switch assembly, bail and control cable are assembled before they are installed on the pin (Fig. 289).



Fig 289

DSC-4908a

# HANDLES & CONTROL CABLES

## 3 Speed Transmission Models

Handles on 3 speed models are basic and easily disassembled.

### 3 Speed Control Cables

The shift cables are not adjustable. To install the shift cable, insert the end of the cable in the shift arm and slip the end of the cable jacket into the bracket (Fig. 290).

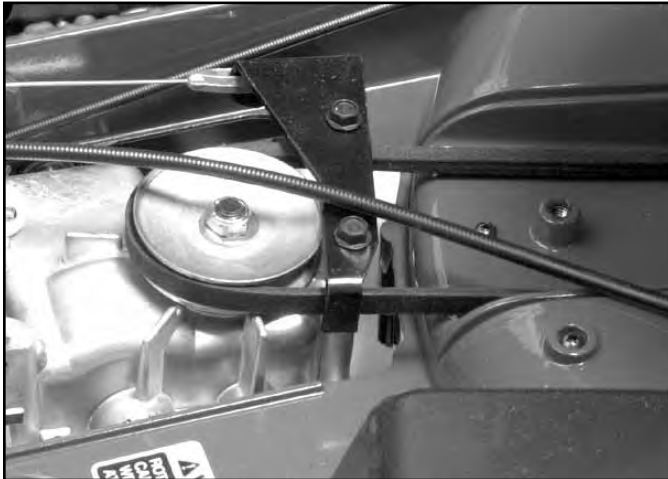

Fig 290

3428-0196

The traction control cable tilts the transmission backward to tighten the belt and engage the transmission (Fig. 291). It must tighten sufficiently to fully drive the transmission, yet allow the transmission to rock forward and loosen the belt to disengage.



Fig 291

3428-0195

The adjustment point for this cable is a knob, jam nuts, or a clamp to the handle (Fig. 292 and Fig. 293).

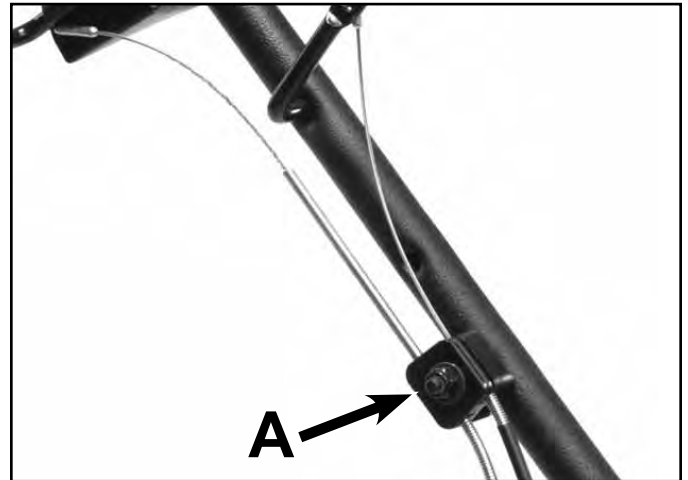

Fig 292

3428-0043-2

A. Clamp

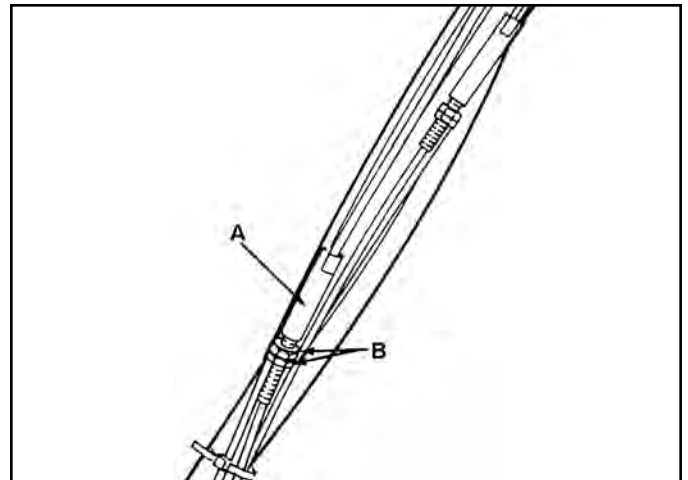

Fig 293

fig 69

A. Blade brake cable

B. Jam nuts

# HANDLES & CONTROL CABLES

The objective is to have the wheels begin to drive when the bail is about 1" (25mm) below the upper handle, yet be able to lower the bail enough to stop the wheels without releasing the bail (Fig. 294).

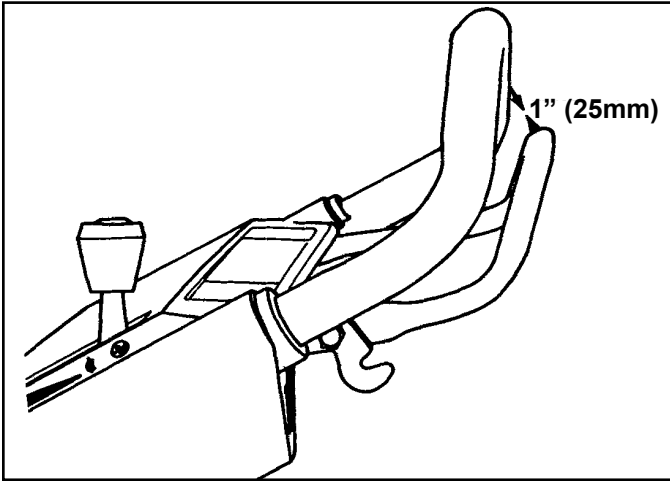

Fig 294

fig 20

To adjust, turn the knob or loosen the cable clamp and slide the cable jacket up or down. Secure with the clamp.

## BBC Cable Adjustment (Toro Vacu Power/Lawn-Boy Medallion)

1. Remove the two flanged head self-tapping screws securing the screen panel to the housing and remove the screen panel (Fig. 295).

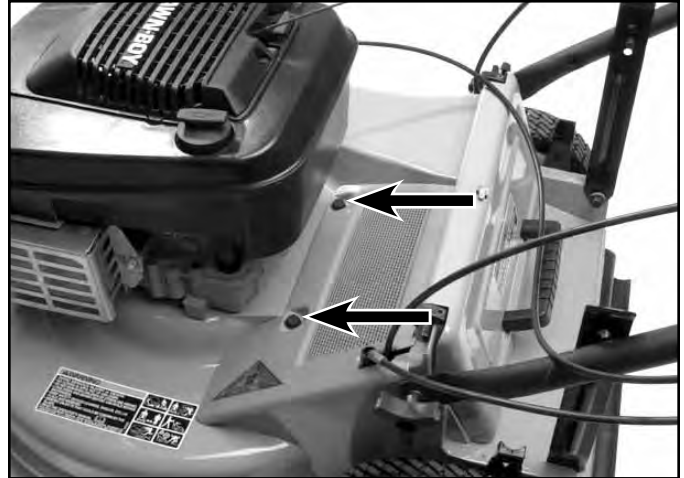

Fig 295

3428-0079

# HANDLES & CONTROL CABLES

2. With the engine off and the spark plug wire disconnected, cock and lift the control bar to engage the blade. Tape the control bar to the handle with the blade engaged, then measure the length of the over-travel spring (Fig. 296). When adjusted properly, it should measure 1" (25mm). If it does, skip ahead to step 5. Otherwise proceed with adjustment in the following step.

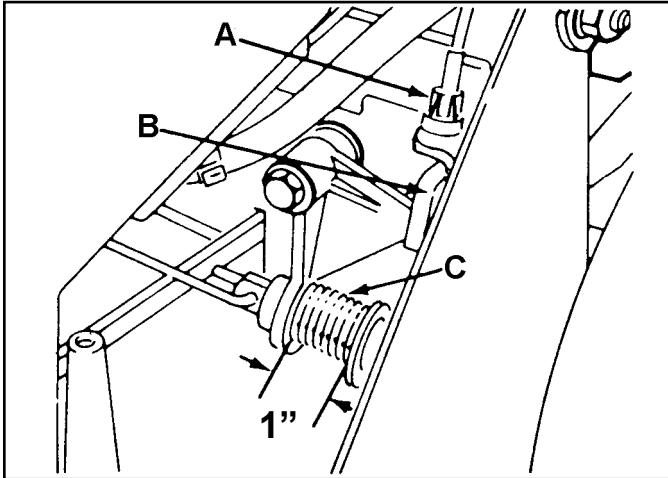

Fig 296

fig. 68

- A. Plastic fitting                      C. Spring  
B. Cable fitting

3. There is a turnbuckle in the cable about halfway between the control panel and the chassis. Adjust the turnbuckle until the over-travel spring measures 1" (25mm).
4. Remove the tape from the handle and disengage the blade.

5. Install the screen panel with the two flanged head self-tapping screws. Make sure that the top edge of the screen panel is under the lip at the top of the housing. The screen is installed, sharp edge down, to allow air to be drawn in through the screen panel on top of the deck and down underneath the deck. This venting improves the airflow underneath the deck thereby improving quality of cut and bagging performance. Be sure to clean the screen on occasion, especially if quality of cut or bagging performance has degraded.

**Note:** An overly tight cable will cause the BBC to disengage before the bail can be raised to the normal operating position. Cock the bail downward and raise to the handle. If the BBC disengages and you hear the brake engage with a snap, the cable is likely too tight. Excessive cable tension causes the control hook in the control box to release. It doesn't do any permanent damage to any parts. Loosen the cable slightly and repeat the test.

On BBC models, the control bail also controls the transmission belt engagement. The adjustment point is a knob about halfway between the control panel and transmission. Ideally, the cable should be set so that the transmission drive will disengage when the bail is lowered about 1" (25mm). This allows the bail to be lowered so that the wheels stop driving and the BBC remains engaged, but the gap isn't so large that the handle is hard to hold (Fig. 297). This measurement is not an exact requirement. It can be varied to accommodate a customer with small hands, etc.

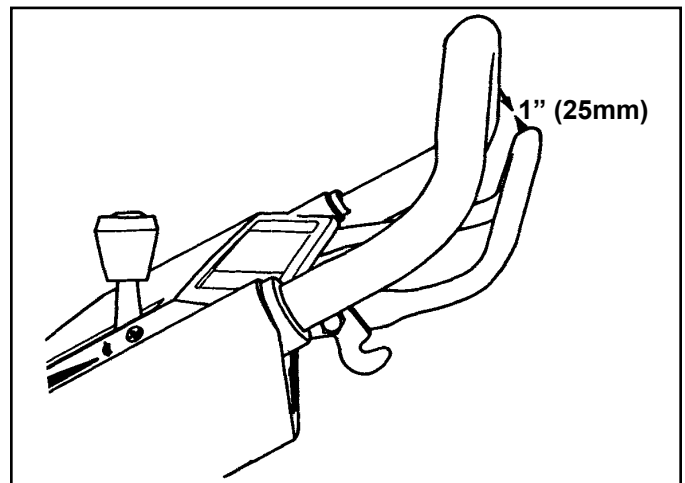

Fig 297

fig 20

# HANDLES & CONTROL CABLES

## Toro BBC Cable Adjustment (Recycler/Rear Bagger)

The cable adjustment is the clamp on top of the housing on the left side of the mower. Loosen the screw holding the cable clamp. Pull the cable to the rear just enough to remove the slack (Fig. 298). Hold and tighten the clamp. The spring on the forward end of the cable should be suspended just off the housing.

**Note:** An overly tight cable will cause the BBC to disengage before the bail can be raised to the normal operating position. Cock the bail downward and raise to the handle. If the BBC disengages and you hear the brake engage with a snap, the cable is likely too tight. Excessive cable tension causes the control hook in the control box to release. It doesn't do any permanent damage to any parts. Loosen the cable slightly and repeat the test.



Fig 298

348-0172

On BBC models, the control bail also controls the transmission belt engagement. The adjustment point is a knob about halfway between the control panel and transmission. Ideally, the cable should be set so that the transmission drive will disengage when the bail is lowered about 1" (25mm). This allows the bail to be lowered so that the wheels stop driving and the BBC remains engaged, but the gap isn't so large that the handle is hard to hold (Fig. 299). This measurement is not an exact requirement. It can be varied to accommodate a customer with small hands, etc.

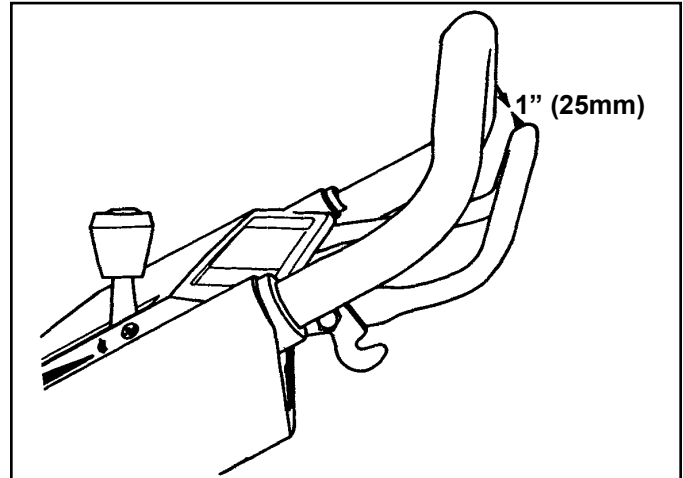

Fig 299

fig 20

# HANDLES & CONTROL CABLES

## Toro BOS Control

The BOS control is the upper bail on the handle. For the required 2 step engagement, there is a pivoting stop on the right hand handle. Rotate it out of the way and then pull the bail down for blade engagement (Fig. 300).

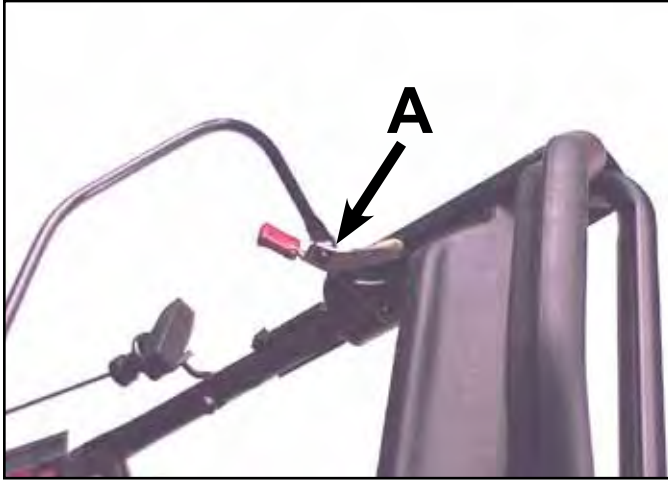

Fig 300

MVC-102

A. Pivoting stop

## Toro BOS Control Cable Adjustment

The blade clutch control is adjusted by removing the cover between the engine and bag door. Loosen the cable clamp and draw the cable to the rear to remove the slack. Now push the cable outer jacket forward  $5/8$ " (1.5cm) and secure. This will create  $5/8$ " (1.5cm) slack in the cable (Fig. 301).



Fig 301

MVC-BOS457X

# HANDLES & CONTROL CABLES

## Lawn-Boy BCS Control

To engage the blade clutch, press the control button. Then pull the control bar to the handle. To disengage the blade, release the control bar. (Fig. 302).



Fig 302

lwpm\_10797a

## Lawn-Boy BCS Control Cable Adjustment

Lawn-Boy Insight and Insight Gold:

1. Remove the grass bag and tunnel (Fig. 303).



Fig 303

DSC-5360a

2. Loosen cable clamp. Draw cable to rear to remove slack. Now push outer jacket of cable forward 5/8" (1.5cm) and secure. This will create 5/8" (1.5cm) slack in the cable (Fig. 304).



Fig 304

DSC-5357a



# HANDLES & CONTROL CABLES

Lawn-Boy Insight Platimun:

1. Remove the gas and oil and tip the mower on its side with the air filter up.
2. Remove the BCS cover and belt cover.
3. Loosen the 2 cap-screws securing the bracket to the housing. Pull the cable to the rear to remove the slack. Push the cable forward 5/8" (1.5cm) and secure. This will create 5/8" (1.5cm) of slack (Fig. 305).



**Fig 305**

DSC-5352a

4. Install the BCS cover, belt cover and tunnel.

## **HANGLES & CONTROL CABLES**

---

**THIS PAGE INTENTIONALLY LEFT BLANK.**

# SELF-PROPEL BELT REPLACEMENT

---

Safety Information . . . . .	1
Worm Drive Transmission . . . . .	2
Single Speed Spur/Bevel Gear Transmission . . . . .	3
Single Speed Bevel Gear Transmission . . . . .	4
Three Speed Transmission . . . . .	5
General Transmissions® . . . . .	6
Wheel Pinion Clutch . . . . .	7
Blade Brake Clutch Systems (BBC), Blade Override System (BOS), Blade Clutch Systems (BCS) . . . . .	8
Handles and Control Cables . . . . .	9
<b>Self-Propel Belt Replacement . . . . .</b>	<b>10</b>

# SELF-PROPEL BELT REPLACEMENT

---

There are several different procedures for replacing the self-propel belt. Mowers with a blade brake clutch (BBC) mechanism are the most complex as parts of that will need to be removed to access the self-propel belt.

## **Toro 21” Front Wheel Drive – Worm Drive Transmission**

See “Worm Drive Transmission” on page 2-1.

These mowers usually have a model number that starts with 16xxx.

Remove the belt cover, push the top of the transmission to the rear to create slack in the belt, and remove the belt. Push the belt towards the engine. If necessary, drain the fuel and oil to prevent spillage. Tip the mower on its side, air filter side up. Slip the belt off the crankshaft pulley. In some cases, there might not be enough clearance blade mower housing. It might be necessary to remove the blade to remove the belt.

Follow the procedure in reverse order to reassemble.

## **21” Steel & Cast Deck – Single Speed Spur/Bevel Gear Transmission**

If necessary, drain the fuel and oil to prevent spillage. Tip the mower on its side, air filter side up. Remove the belt cover. Loosen or remove the belt guides so the belt can be replaced without forcing it off. See the “Single Speed Spur/Bevel Gear Transmission” section for a typical transmission and drive layout, on page 3-1.

Follow the procedure in reverse order to reassemble.

## **22” Front Wheel Drive – Single Speed Bevel Gear Transmission**

See “Single Speed Bevel Gear Transmission” on page 4-1.

These mowers usually have a model number that starts with 200XX.

If necessary, drain the fuel and oil to prevent spillage. Tip the mower on its side, air filter side up. Remove the two belt cover mounting screws. DO NOT bend the belt guides or force the belt between the pulley and belt guide. Loosen or remove the mounting screws to pivot the belt guides out of the way. If the belt guides are bent or out of place, the belt may have a tendency to jump

and may not disengage properly. It may be necessary to remove the blade to replace the belt. Do not force the new belt between the blade and mower housing. A nick or cut in the new belt can cause premature failure.

Follow the procedure in reverse order to reassemble.

## **22” Rear Wheel Drive – Single Speed Bevel Gear Transmission**

Toro and Lawn-Boy steel deck models

In order to replace the self-propel drive belt the transmission must be removed from the chassis. This is necessary to access the pulley and belt guide on top of the transmission. See “Single Speed Bevel Gear Transmission, Rear Wheel Drive Models, Transmission Removal and Belt Replacement”, on page 4-10.

If necessary, drain the fuel and oil to prevent spillage. Tip the mower on its side, air filter side up. DO NOT bend the belt guides or force the belt between the pulley and belt guide. Loosen or remove the mounting screws to pivot the belt guides out of the way. If the belt guides are bent or out of place, the belt may have a tendency to jump and may not disengage properly. It may be necessary to remove the blade to replace the belt. Do not force the new belt between the blade and mower housing. A nick or cut in the new belt can cause premature failure.

Follow the procedure in reverse order to reassemble.

## **21” Lawn-Boy Insight Mowers**

The Zone Start models use a basic self-propel system. See “Transmission Remove and Replace”, on page 4-19, which also explains the belt replacement process.

# SELF-PROPEL BELT REPLACEMENT

---

## **21” Cast Deck Mowers – 3 Speed Transmission**

Toro and Lawn-Boy models

If necessary, drain the fuel and oil to prevent spillage. Tip the mower on its side, air filter side up. Remove the belt cover, just behind the engine on top of the mower, to access the transmission. DO NOT bend the belt guides or force the belt between the pulley and belt guide. Loosen or remove the mounting screws to pivot the belt guides out of the way. If the belt guides are bent or out of place, the belt may have a tendency to jump and may not disengage properly. It may be necessary to remove the blade to replace the belt. See the on the “Three-Speed Transmission” section starting on page 5-1.

Follow the procedure in reverse order to reassemble.

## **20”, 21”, 22”, 48cm, 50cm, & 53cm Steel & Cast Deck – General Transmission**

Toro and Lawn-Boy models

See the appropriate section in the “General Transmission” chapter, starting on page 6-1, for self-propel belt replacement instructions.

## **21” Toro & Lawn-Boy Mowers with Blade Brake Clutch**

Part of the BBC must be disassembled to access the self-propel belt. See the “BBC, BOS, BCS” section starting on page 8-1 for more information.

## **21” Toro Mowers with Blade Override System (BOS) & Lawn-Boy Mower with Blade Clutch System (BCS)**

Part of the BOS or BCS must be removed to replace the self-propel belt. See the “BOS, BCS” section on page 8-29 for more information. The Lawn-Boy Insight has a black access cover just to the rear of the engine on top of the chassis. Remove it for easy access to the top of the transmission.

# **SELF-PROPEL BELT REPLACEMENT**

---

**THIS PAGE INTENTIONALLY LEFT BLANK.**



---

---

---

---

# **Walk Power Mower Drive Systems Service Manual**