

MODEL: 38225-0000001 & UP
MODEL: 38235-0000001 & UP

**OPERATOR'S
MANUAL**

TORO S200 SNOWTHROWER
(RECOIL AND ELECTRIC START)



PRICE \$1.00

FOREWORD

The S200 is an outstanding product for throwing snow. It has advanced concepts in engineering, design and safety; and if maintained properly, the S200 will be reliable.

Since the S200 is a quality product, Toro is concerned about its future use and the safety of the user. Therefore, read this manual to familiarize yourself with correct set-up, operation, and maintenance. The five major sections of the manual are:

1. Safety Instructions
2. Setting Up Instructions
3. Preparation Before Starting
4. Operating Instructions
5. Maintenance

Some information in this manual needs emphasizing. The words CAUTION, IMPORTANT, and NOTE are used to classify the information. "Caution" identifies personal safety related information. "Important" identifies mechanical information demanding special attention. Be sure to read the directive because it has to do with the possibility of damaging a part or parts of the snowthrower. "Note" identifies general information worthy of special attention.

If help — concerning the snowthrower — is ever needed, contact the local Authorized TORO Service Dealer or TORO Distributor. Refer to the yellow pages for assistance. In addition to genuine TORO replacement parts, the dealer and distributor have other TORO products and many accessories for these products.

TABLE OF CONTENTS

	Page
Safety Instructions	3-4
Safety Decals	4
Specifications	5
Loose Parts	5
Setting Up Instructions	6
Install Wheels	6
Install Upper Handle	6
Controls	7
Preparation Before Starting	8-9
Mix Gasoline and Oil	8-9
Fill Fuel Tank	9
Starting and Stopping Instructions	10
Operating Instructions	10-11
Adjusting Vanes	10
Operating Tips	10-11
Maintenance	12-15
Lubricating Snowthrower	12
Replacing Nylon Scraper	12
Replacing Drive Belt	12
Adjusting Carburetor	13
Replacing Spark Plug	14
Preparing Snowthrower for Storage	15
Identification and Ordering	15
The Toro Promise	Back Page

SAFETY INSTRUCTIONS



This safety alert symbol means **CAUTION – PERSONAL SAFETY INSTRUCTION**. Read the instruction because it has to do with safety. Failure to comply with the instruction may result in personal injury.

The snowthrower is designed and tested to offer reasonably safe service, provided it is operated in strict accordance with the following Safety Instructions. Failure to comply with the following instructions **MAY RESULT IN PERSONAL INJURY**.

BEFORE OPERATING

1. Never allow children to operate the snowthrower. Adults should operate the snowthrower only after **READING THIS MANUAL** and receiving proper instructions.
2. Familiarize yourself with the controls. Know how to stop the engine and disengage controls quickly.
3. Keep everyone, especially children and pets, away from the area of operation.
4. Wear adequate winter clothing and footwear that will improve footing on slippery surfaces.
5. Since fuel is highly flammable, handle it with care. Fill fuel tank with mixture of gasoline and oil before trying to start the engine.
 - A. Use an approved fuel container for storing the gasoline/oil mixture.
 - B. Fill fuel tank outdoors, not indoors. Fuel tank must not be filled when engine is running or when engine is hot.
 - C. Install gasoline container cap and fuel tank cap, and wipe up any spilled gasoline before starting the engine.
6. Thoroughly inspect the area where snowthrower will be used. Remove all door mats, sleds, boards, wires, and any other foreign objects.
7. Keep all shields and safety devices in place. If a shield or safety device is defective, make all repairs before operating snowthrower. Also tighten loose nuts, bolts, and screws.
8. Start engine and let it warm up outdoors for about two minutes to adjust to outdoor temperature before clearing snow.

WHILE OPERATING

9. Use only the extension cord provided with the S200 Electric Start.
10. Do not plug extension cord into outlet while standing in water or when hands are wet.
11. Do not use or connect cord if gasoline has been spilled on it.
12. Always replace a damaged extension cord immediately.
13. Never operate snowthrower without good visibility or light. Always maintain secure footing and keep a firm grip on the handle when clearing snow; walk never run. **DO NOT USE SNOWTHROWER ON A ROOF.**
14. Do not run engine indoors.
15. Keep face, hands, feet, and any other part of your body or clothing away from concealed, moving, or rotating parts. Stay behind the handle while operating the snowthrower. **STAY CLEAR OF DISCHARGE OPENING AT ALL TIMES.**
16. Do not attempt to make adjustments while engine is running.
17. Use extreme caution when clearing snow from a walk, road or a gravel drive. Push down on handle to raise skid and impeller blades so rocks are not picked up and thrown. Stay alert for hidden hazards and traffic on roads.
18. Never direct discharge or operate snowthrower near bystanders, glass enclosures, automobiles and trucks, window wells, or a drop-off without proper adjustment of the snow discharge angle. Keep children and pets away.
19. Never direct snow discharge at bystanders, and do not allow anyone in front of the snowthrower.
20. Never clear snow from steep slopes. Exercise extreme caution when changing direction on slopes.
21. Do not overload the snowthrower by clearing snow at too fast a rate.
22. If a solid object is hit or if the snowthrower vibrates abnormally, turn key to OFF and wait for engine and all moving parts to stop. Next, check snowthrower for possible damage, an obstruction, or loose parts. Repair damage before starting and operating the snowthrower.

SAFETY INSTRUCTIONS

23. Before leaving the operator's position – behind handle – shut engine off and wait for all moving parts to stop. Remove key from switch if snowthrower will be left unattended.
24. Before adjusting, cleaning, repairing and inspecting the snowthrower, and before unclogging the discharge guide, shut engine off and wait for all moving parts to stop.
25. Let engine run for a few minutes after clearing snow so moving parts do not freeze.

MAINTENANCE AND STORAGE

26. When storing the snowthrower, REMOVE KEY FROM SWITCH. Store key in a memorable place.
27. Never leave fuel in the snowthrower fuel tank when snowthrower is stored in a building where there is flame or spark present. Allow engine to cool before storing. Never store snowthrower in

house or basement, as gasoline and fumes are highly flammable, explosive and dangerous if inhaled.

28. Before performing any maintenance or servicing the snowthrower, turn key to OFF and wait for engine and all moving parts to stop. Remove key from switch.

29. Reinstall fuel cap when top cover is removed for maintenance procedures. Perform maintenance and use storage instructions described in this manual.

30. Keep all nuts, bolts, and screws tight to assure snowthrower is in safe working condition. Be sure to check the rotor and engine mounting bolts.

31. ALWAYS USE TORO REPLACEMENT PARTS AND ACCESSORIES TO ASSURE SAFETY AND OPTIMUM PERFORMANCE. NEVER USE "WILL-FIT" REPLACEMENT PARTS AND ACCESSORIES.



SAFETY DECALS

Safety and instruction decals are located on the impeller housing and control panel. Replace any decal that is damaged.

ON CONTROL PANEL



RECOIL START

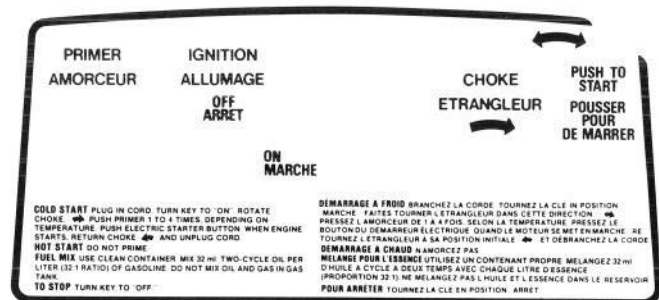

ELECTRIC START

WARNING

• KEEP HANDS OUT OF DISCHARGE GUIDE AND KEEP CLEAR OF IMPELLER WHILE ENGINE IS RUNNING.

- DO NOT DIRECT DISCHARGE AT BYSTANDERS OR WINDOWS
- STOP ENGINE AND WAIT FOR ALL MOVEMENT TO STOP BEFORE SERVICING MACHINE
- READ OPERATORS MANUAL FOR COMPLETE SAFETY AND OPERATING INSTRUCTIONS. FREE OPERATORS MANUALS ARE AVAILABLE FROM THE TORO COMPANY, MINNEAPOLIS, MINN. 55420. SPECIFY MODEL AND SERIAL NUMBERS

ATTENTION

• GARDEZ LES MAINS HORS DU GUIDE D'EJECTION ET DEMEUREZ A L'ECART DU ROTOR LORSQUE LE MOTEUR TOURNE.

- NE DIRIGEZ PAS LA NEIGE VERS LES PERSONNES OU LES FENETRES.
- ARRÊTEZ LE MOTEUR ET ATTENDEZ QUE TOUT MOUVEMENT AIT CESSÉ AVANT DE DÉBLOQUER OU RÉPARER LA MACHINE
- LISEZ À FOND LES RÈGLES DE SÉCURITÉ ET D'UTILISATION DANS LE MANUEL D'UTILISATION. ON PEUT OBTENIR DES MANUELS D'UTILISATION GRATUITS DE LA COMPAGNIE TORO, MINNEAPOLIS, MINN. 55420. EN MENTIONNANT LES NUMÉROS DE MODÈLE

SPECIFICATIONS

Tecumseh Engine: Model AH520, two cycle, air cooled engine with an output of 2.25 hp (1.67 kw) @ 4300 rpm and 2½-ft-lb (3.4 N·m) of torque @ 3000-4000 rpm. Displacement is 5.2 cubic inches (85.3 cc). Compression release and primer are for easy starting.

Fuel Tank: Tank is made of polyethylene and has an approximate capacity of one quart (0.946 l). The winterized fuel tank cap has a side vent.

Muffler: Welded steel muffler has diameter of 2 inches (50.8 mm) and length of 14 inches (0.356 m). Because of its volume and configuration, muffler quiets exhaust noise and directs exhaust toward ground.

Impeller: Two section, drum-type impeller is made of aluminum, and two rubber blades are mounted between the halves. Impeller is supported by a ball bearing on the drive end and an oil impregnated bronze bearing on the other end. Diameter of impeller is approximately 8 inches (0.203 m), length is approximately 18 inches (0.457 m).

Impeller Housing: Width between side plates is 20 inches (0.508 m).

Impeller Drive: Drive is belt type with spring loaded idler pulley. Reduction from engine to impeller is 4.4:1.

Tires: Tire is 6 inches (0.152 m) in diameter, 1½ inches (38 mm) wide, and has lug-type tread.

Frame: Formed aluminum side plates, steel engine mounting bracket, and muffler form an integral frame to support engine and impeller.

Handle: Two 7/8 inch (22 mm) diameter aluminum tubing handles have vinyl coating at grip areas.

Controls: Mounted on the control panel are a key-type switch, primer, choke, recoil starter, and electric start button on S200 Electric Start. Vane control is mounted on right side of lower handle.

Dimensions:

Overall width is approximately 20½ inches (0.521 m).

Overall length is approximately 39 inches (0.991 m).

Overall height is approximately 36 inches (0.914 m).

Electric System: (Model 38235 only) C.S.A. approved, double insulated system with permanent magnet motor equipped with bendix drive for high impact plastic pinion; aluminum mounting bracket. C.S.A. approved, 10 foot (3.05 m) extension cord. Motor rated 6.0 amps, 115 VAC.

LOOSE PARTS

Note: Using care, remove snowthrower and other parts from carton. Use chart below to assure all parts have been shipped.

Description	Qty.	Use
Electric Extension Cord (Electric Start Only)	1	Use to start engine.
Wheel	2	Install wheels on axle.
Axle	1	Slide axle through mounting brackets.
Washer	2	Slide washers onto axle.
Push Nut	2	Use nuts to hold wheels on axle.
Upper Handle	1	Mount upper handle against outside of lower handle.
Machine Screw	4	Screws are used to mount upper handle.
Key	2	Use key in ignition switch.
Operator's Manual	1	Read operator's manual before operating snowthrower.
Registration Card	1	

SETTING UP INSTRUCTIONS

Note: Stand behind the snowthrower and face forward to determine left and right sides.

INSTALL WHEELS

Tools Required: Hammer

1. Install one push nut onto end of axle (Fig. 1) by placing nut on flat surface, inserting end of axle shaft and striking opposite end of shaft lightly with a hammer.
2. Slide wheel onto axle and against push nut (Fig. 1). Make sure hub side of wheel with six spokes is toward center of axle.
3. Slide flat washer onto end of axle and against side of wheel hub (Fig. 1).

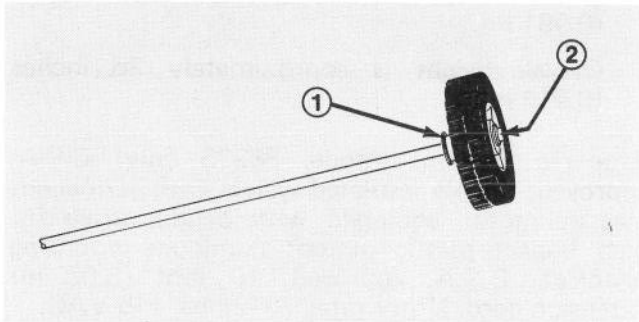

Figure 1

1. Flatwasher
2. Push nut

4. Slide axle through both mounting brackets (Fig. 2). Note position of flat washer (Fig. 2).

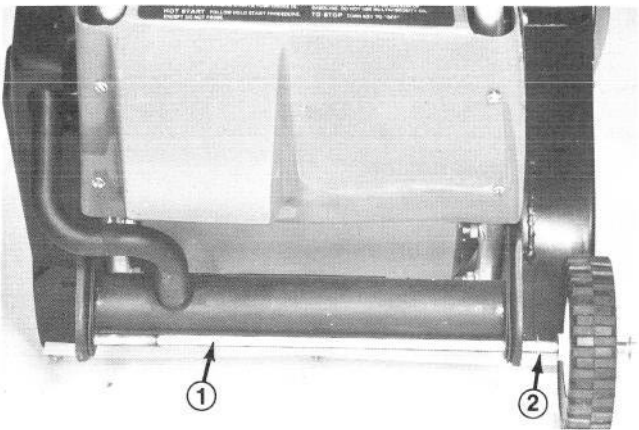

Figure 2

1. Axle
2. Washer

5. Tip snowthrower onto side that has wheel mounted; then put a wooden block under the wheel so push nut contacts block. Next, slide flat washer and wheel onto axle assuring that hub side of wheel is toward center of axle. Drive push nut onto end of axle to retain wheel in place.

INSTALL UPPER HANDLE

Tools Required: Screwdriver

1. Set snowthrower upright on its wheels.
2. Slide upper handle down between lower handle and shroud (Fig. 3). Line up holes in shroud, upper handle, and lower handle (Fig. 3).

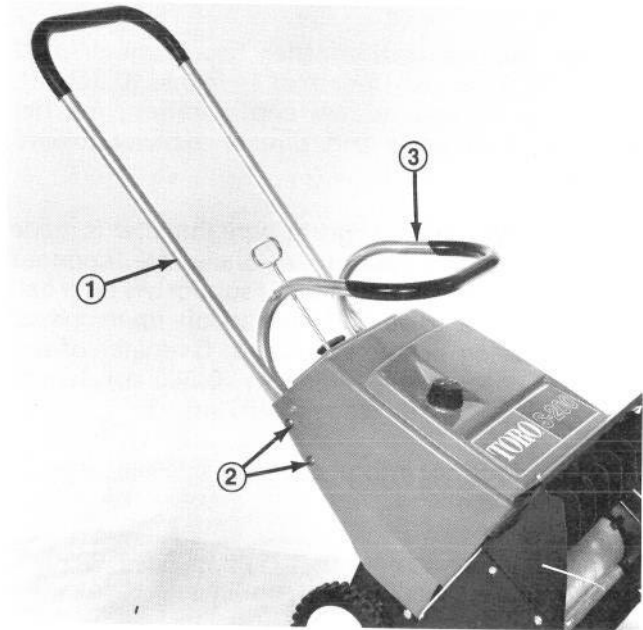

Figure 3

1. Upper handle
2. Line up holes
3. Lower handle

3. Secure both sides of handle in place with four machine screws (Fig. 4). Tighten screws securely.

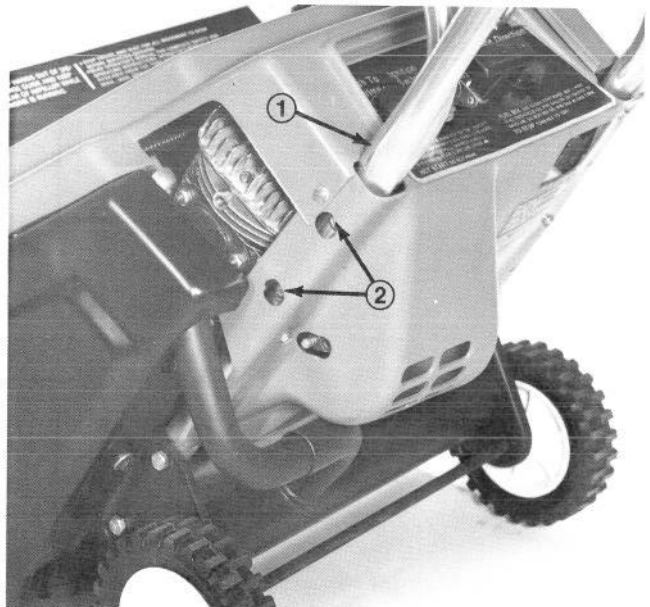

Figure 4

1. Handle
2. Screws

CONTROLS

1. Primer (Fig. 5) — Push primer to pump a small amount of fuel into the carburetor, which allows the engine to be started easier in cold temperatures. **DO NOT USE PRIMER WHEN ENGINE IS HOT.**

2. Choke (Fig. 5) — Rotate choke clockwise to start engine. Because air intake into carburetor is restricted, engine receives a rich fuel mixture for easy starting.

3. Ignition Switch (Fig. 5) — Switch has ON and OFF position. Rotate key to ON to open the switch; then engine can be started by pulling recoil starter or pushing start button on S200 Electric Start. Rotate key to OFF to stop the engine.

4. Electric Start Plug-in (Fig. 6) — Insert electric start cord. Plug opposite end of cord into 115 VAC electrical outlet to provide power for electric starter.

5. Electric Starter (Fig. 6) — Push start button to start engine.

6. Recoil Starter (Fig. 5) — Pull recoil starter to start the engine.

7. Vane Direction Control (Fig. 5 and 6) — Rotate vane control to direct discharge of snow to either side or straight forward.

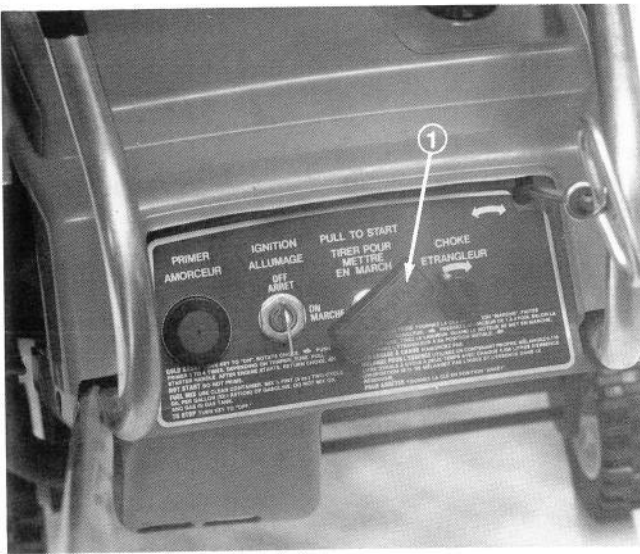

Figure 5

1. Recoil starter

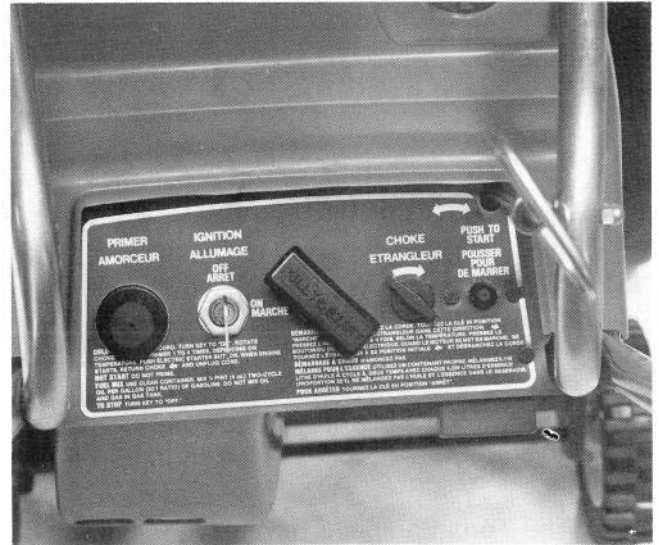

Figure 6



Recoil Start



Electric Start

PREPARATION BEFORE STARTING



CAUTION

Gasoline is flammable and caution must be used when handling or storing it. Do not fill fuel tank while snowthrower is running, hot, or when snowthrower is in an enclosed area. Keep away from open flame, electrical spark, and **DO NOT SMOKE** while mixing fuel or filling the fuel tank. Fill fuel tank to within 1/4 – 1/2 inch (6.3 – 12.7 mm) from top of tank to provide space for expansion of fuel. Never fill fuel tank to top of filler neck. Always fill fuel tank outdoors and use a funnel or spout to prevent spilling. Make sure to wipe up any spilled fuel before starting the engine.

Store gasoline in a clean, approved container, and keep the cap in place on the container. Keep gasoline in a cool, well ventilated place; never in the house. Never buy more than a 30 day supply of gasoline to assure volatility. Gasoline is intended to be used as a fuel for internal combustion engines; therefore, do not use gasoline for any other purpose. Since many children like the smell of gasoline, keep it out of their reach because the fumes are dangerous to inhale, as well as being explosive.

MIX GASOLINE AND OIL

Tools Required: Gas Can, Funnel, and Clean Rag

The two cycle engine used in the S200 requires a mixture of GASOLINE and OIL for lubrication of bearings and other moving parts. The correct fuel mixture ratio is 32:1.

Note: Gasoline and oil must be premixed in a clean gasoline container. Never mix gasoline and oil indoors or in the snowthrower fuel tank. Always use fresh gasoline.

Store the oil indoors, so it will be at room temperature (above 50° F [10° C] and will more readily mix with the gasoline.

Note: The Toro Company recommends the use of TORO 2 cycle engine oil for optimum performance and engine longevity. This oil has been specially formulated for use in the S-200 snowthrower and may be obtained from your local TORO dealer.



CAUTION

Do not store the oil near open flame or in an extremely warm environment as the oil is flammable.

IMPORTANT: When mixing fuel be sure to use the correct amounts of oil and gasoline depending on the units of measurement being used: U.S. Gallons, Imperial Gallons or Liters. Using an incorrect fuel mixture may result in damage to your snowthrower.

U.S. GALLONS

1. Add 1 U.S. quart of leaded or unleaded **REGULAR** gasoline to a gasoline container (Fig. 7).
2. Pour 1/2 cup – 4 oz – of two cycle engine oil into the gasoline container (Fig. 7). **DO NOT** use multi-viscosity oils.
3. Shake the gasoline container vigorously so oil mixes with gasoline (Fig. 7). Remember to install cap on gasoline container before shaking.
4. Add an additional 3 U.S. quarts of gasoline to the premixed gasoline (Fig. 7). Fuel mixture is now ready to use in your S200 Snowthrower.



Figure 7

PREPARATION BEFORE STARTING

IMPERIAL GALLONS

1. Add 1 Imperial quart of leaded or unleaded REGULAR gasoline to a gasoline container (Fig. 7B).
2. Pour 5 Imperial oz. of two cycle engine oil into the gasoline container (Fig. 7B). DO NOT use multi-viscosity oils.
3. Shake the gasoline container vigorously so oil mixes with gasoline (Fig. 7B). Remember to install cap on gasoline container before shaking.
4. Add an additional 3 Imperial quarts of gasoline to the gasoline container (Fig. 7B).

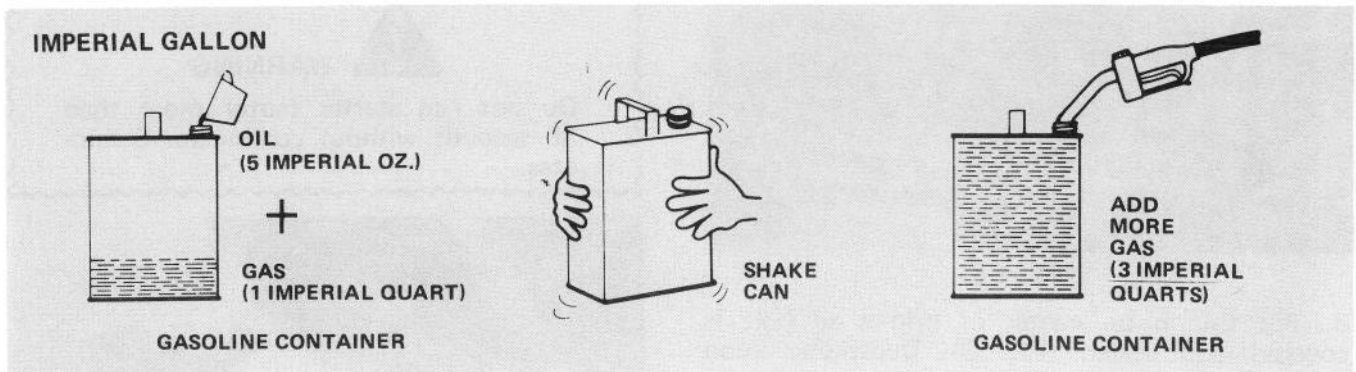

Figure 7B

LITERS

1. Add 250 milliliters of leaded or unleaded REGULAR gasoline to a gasoline container (Fig. 7C).
2. Pour 32 milliliters of two cycle engine oil into the gasoline container (Fig. 7C). DO NOT use multi-viscosity oils.
3. Shake the gasoline container vigorously so oil mixes with gasoline (Fig. 7C). Remember to install cap on gasoline container before shaking.
4. Add an additional 750 milliliters of gasoline to the gasoline container (Fig. 7C).

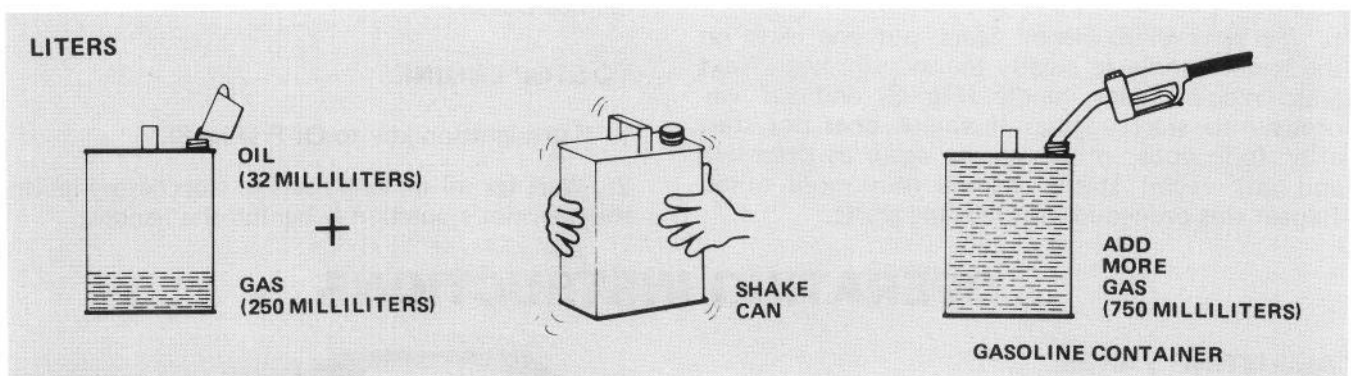

Figure 7C

FILL FUEL TANK

Tools Required: Funnel and Clean Rag

IMPORTANT: Do not fill fuel tank with gasoline that does not have oil mixed in it. Do not use gasoline additives because the engine could be damaged.

1. Mix gasoline and oil; refer to Mix Gasoline and Oil, page 8.
2. Clean area around snowthrower fuel tank cap
3. Shake fuel mixture in gasoline container; then fill snowthrower fuel tank to within $\frac{1}{4}$ – $\frac{1}{2}$ inch (6.3–12.7 mm) from the top of the tank, not the filler neck.
4. Install cap securely on snowthrower fuel tank.

so foreign matter does not get into fuel tank. Remove cap from fuel tank.

3. Shake fuel mixture in gasoline container; then fill snowthrower fuel tank to within $\frac{1}{4}$ – $\frac{1}{2}$ inch (6.3–12.7 mm) from the top of the tank, not the filler neck.

Note: When filling fuel tank with gasoline/oil mixture that has been sitting for some time, shake the mixture first because the oil may have settled.

4. Install cap securely on snowthrower fuel tank.

STARTING AND STOPPING INSTRUCTIONS

TO START ENGINE:

1. Check the impeller and blades. There must not be an obstruction; impeller must be free to rotate.
2. Rotate choke clockwise (Fig. 8).

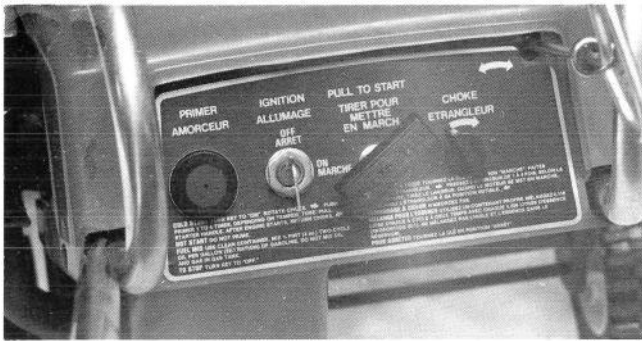

Figure 8

3. Put thumb on center of primer so hole is covered and sealed (Fig. 8). Depending upon temperature at which the machine is stored, push the primer one to four times. For temperatures above +20° F (-7° C) use one or two primes; below +20° F (-7° C), use three or four primes; for extremely cold temperatures below -10° F (-23° C) use five to six primes.

Note: If engine is hot, do not use primer. Only use primer when engine is cold. However, rotate choke to start a hot engine.

4. Turn ignition key to ON (Fig. 8).
5. To start S200 Recoil Start, put one hand on the lower handle to steady the snowthrower. Next grasp recoil starter handle (Fig. 8) and pull vigorously to start engine. If engine does not start after four pulls, prime engine again as described and pull recoil starter handle four more times. Repeat this procedure until engine starts.

To start S200 Electric Start, plug in extension cord (Fig. 9) and push start button (Fig. 7). If engine does not start within 10 seconds, repeat priming and starting procedure until the engine starts.

6. When engine starts, rotate choke counter-clockwise.

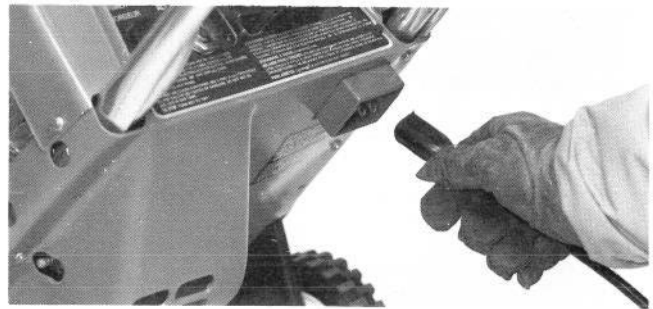

Figure 9

If engine does not start, starts hard or operates erratically, a carburetor adjustment may be required: refer to Adjusting Carburetor, page 13. If engine will not start or runs erratically after adjustment, contact your local Authorized Toro Service Dealer.

TO STOP ENGINE:

1. Turn ignition key to OFF (Fig. 8).
2. Wait for all moving parts to stop before leaving the operator's position – behind the handles.

OPERATING INSTRUCTIONS

ADJUSTING VANES

Rotate vane direction control (Fig. 10) to direct discharge of snow to either side or to the front. After clearing snow, rotate vane control so vanes are in vertical position, not to either side. If vanes are allowed to remain in a side position, the vanes may distort and take a somewhat permanent set. The set affects the normal and efficient discharge of snow.

OPERATING TIPS

1. Use only a 32:1 gasoline/oil mixture ratio for running the engine.
2. The snowthrower is designed to operate at temperatures not to exceed +45° F (7° C). When

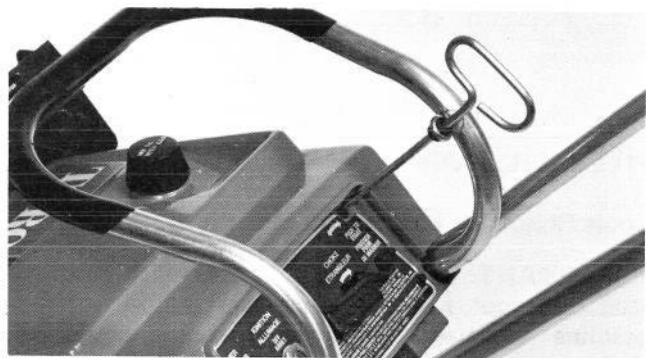

Figure 10

1. Vane control

unit is operated in temperatures above +45° F (7° C), engine may overheat.

OPERATING INSTRUCTIONS

3. Thoroughly inspect area where snowthrower will be used. Remove door mats, sleds, toys, boards, wires, and anything else that may have been covered by the snow. While clearing snow, objects such as the preceding ones could be picked up and thrown by the impeller blades.

4. For most efficient snow throwing, keep vanes vertical, discharge snow downwind, and overlap each swath slightly (Fig. 11).

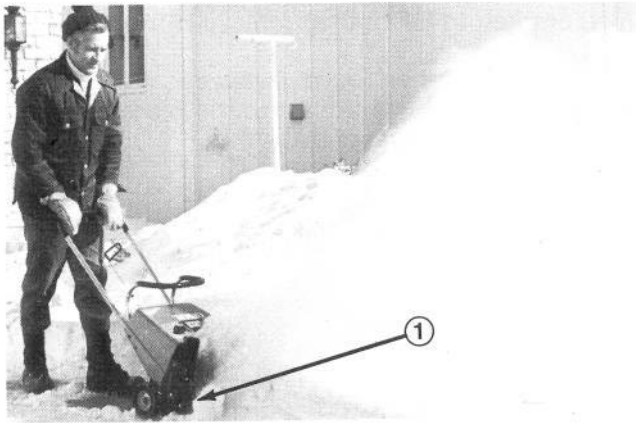

Figure 11

1. *Overlap in heavy snow*

5. When clearing snow from steps or cutting through deep drifts, hold snowthrower by the upper and lower handles and use a sweeping side to side motion (Fig. 12).

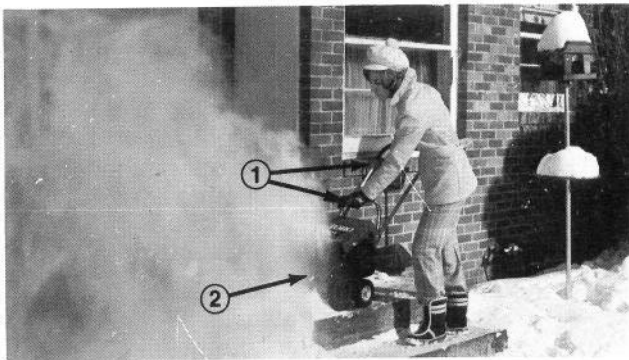

Figure 12

1. *Hold both handles*
2. *Use swinging or sweeping motion*



CAUTION

Use caution when operating snowthrower as exhaust tube is hot and could cause damage to clothing or personal injury.

6. The snowthrower will self propel itself when it is tilted forward so impeller blades contact the ground. However, the depth and weight of the snow govern the forward speed of the snowthrower.

7. Before storing the snowthrower, let engine run for a few minutes so ice does not form on moving parts. Wipe ice and snow off control panel and top of upper shroud so control linkages do not freeze.

8. Move vanes to vertical position when storing snowthrower. Hang snowthrower by upper handle for convenient storage (Fig. 13).

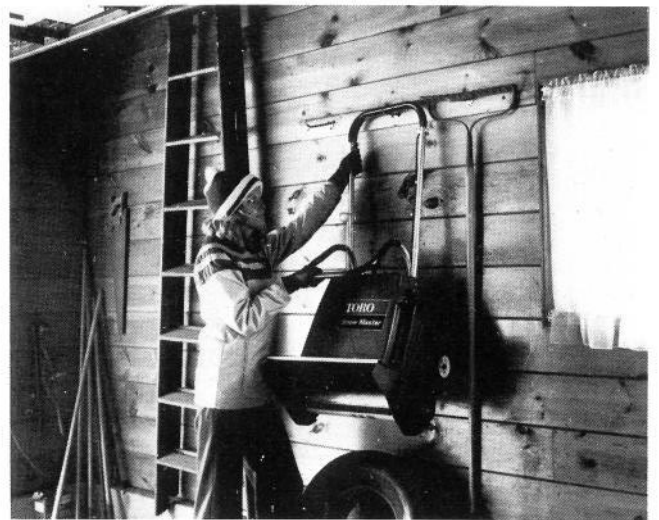

Figure 13

MAINTENANCE



CAUTION

To prevent accidental starting of the engine while performing maintenance, turn ignition key to OFF and remove it from switch.

LUBRICATING SNOWTHROWER

Tools Required: None

The snowthrower does not have to be lubricated because all bearings are lubricated for the life of the product; therefore no other lubrication is required.

REPLACING NYLON SCRAPER

Tools Required: 3/8 Inch Wrench

1. If fuel tank is not empty, drain fuel from tank.
2. Tip snowthrower on its right side.
3. Remove three locknuts and carriage bolts holding scraper against bottom of impeller housing (Fig. 14).

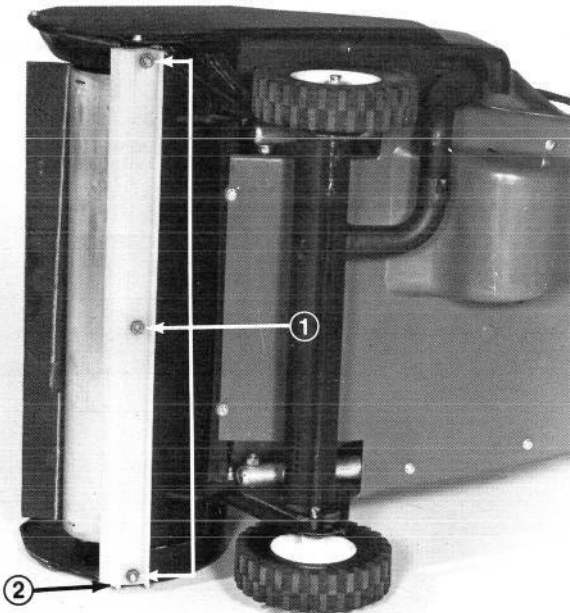

Figure 14

1. Locknuts and carriage bolts
2. Scraper

4. Install new scraper with three carriage bolts and locknuts (Fig. 14).

REPLACING DRIVE BELT

Tools Required: 7/16 Wrench, 5/16-Inch Wrench and 3/8-Inch Wrench

The belt that drives the impeller is tensioned by a spring loaded idler pulley which compensates for belt wear. However, after many hours of use, the belt may be worn severely, causing the impeller to slip. If impeller slips, check and replace the belt if it is worn.

1. Turn key to OFF; then remove it from switch.
2. Remove washer faced capscrew, four screws, and locknuts holding drive cover in place (Fig. 15). Remove cover and set it aside.

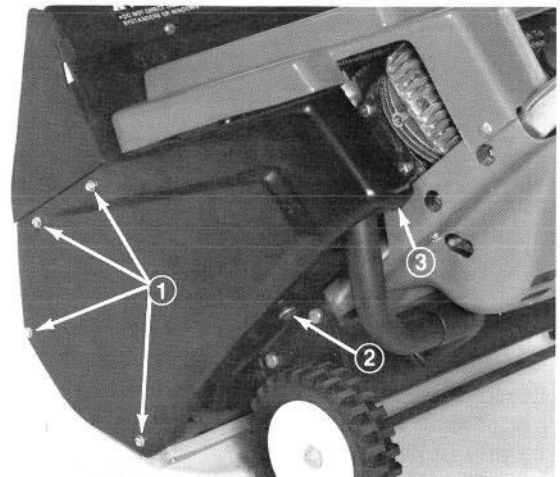

Figure 15

1. Screws
2. Washer faced capscrew
3. Cover

3. Move idler pulley up and pull drive belt out (Fig. 16) so it is free; then allow spring loaded idler to release, but do not let idler pulley snap.

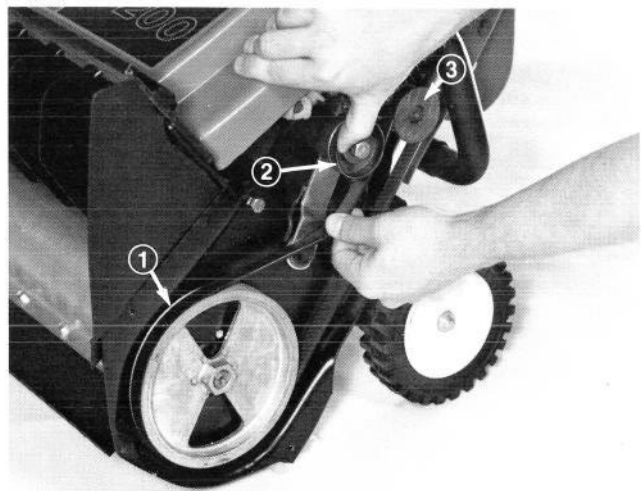

Figure 16

1. Impeller pulley
2. Idler pulley
3. Engine pulley

MAINTENANCE

4. Remove drive belt from impeller pulley and engine pulley (Fig. 16).

5. To install new belt, loop belt around engine pulley, under the idler pulley, and start the belt around the impeller pulley (Fig. 17).

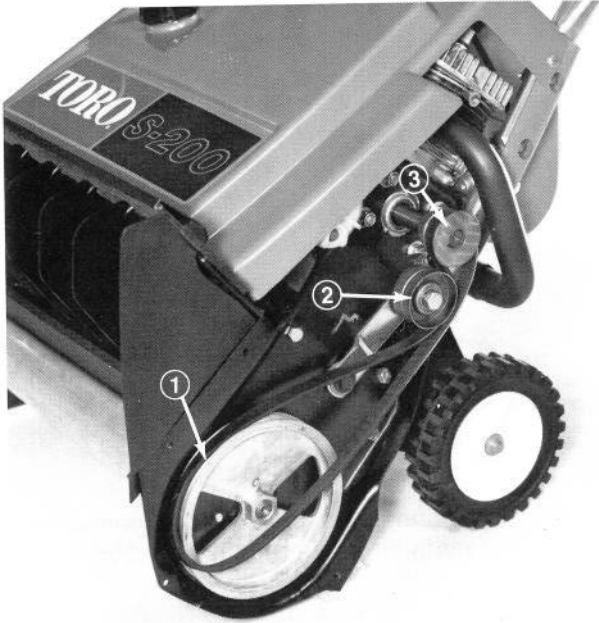

Figure 17

1. Impeller pulley
2. Idler pulley
3. Engine pulley

6. Pull idler pulley up and rotate impeller pulley forward so belt rolls onto it (Fig. 18).



Figure 18

7. Install drive cover with washer face capscrew, four screws, and locknuts (Fig. 15).

ADJUSTING CARBURETOR

Tools Required: Screwdriver

The carburetor has been adjusted at the factory, but an adjustment may be required to compensate for differences in fuel, temperature and altitude.

IMPORTANT: Do not close mixture adjustment screw too tight because the screw and seat will likely be damaged.

1. Mixture Adjustment Screw (Fig. 19) — Close screw by gently rotating it clockwise until a slight seating resistance is felt. Next, rotate mixture adjusting screw 1-1/4 turns counterclockwise.

Note: This setting is approximate; however, this setting will allow engine to be started so carburetor can be fine tuned — steps 2-3.

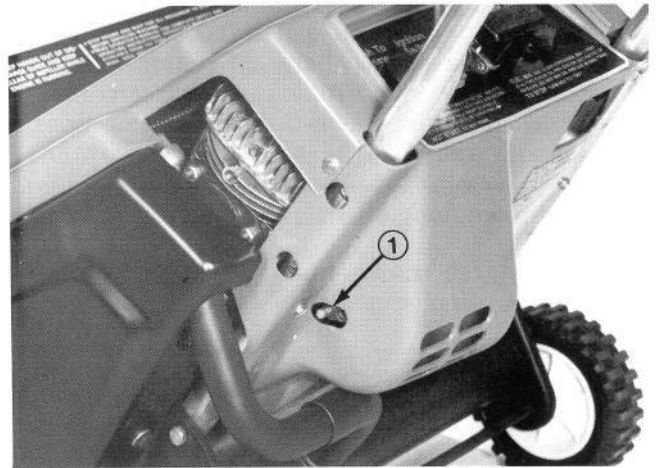

Figure 19

1. Mixture adjustment screw



CAUTION

Engine must be running so final adjustment of the carburetor can be performed. Stay away from rotor because it turns while engine is running. To guard against possible personal injury, keep hands, feet, and face away from concealed, moving, or rotating parts.

2. Start the engine and let it warm up for approximately 3 - 5 minutes. Do not adjust carburetor when engine is cold. Be sure to perform carburetor adjustments while at a temperature that will be the average outdoor temperature at which the machine will be used.

MAINTENANCE

3. With engine running, turn mixture adjustment screw slowly clockwise until engine falters. Remember this location. Now turn screw counterclockwise until engine just starts to sputter. Remember this location. Turn screw clockwise until it is halfway between your first position where your engine faltered and your last position where engine started to sputter. This should be the optimum setting on your carburetor.

Note: In extremely low temperatures or heavy loading conditions the mixture adjustment screw may have to be rotated counterclockwise another 1/8 turn.

REPLACING SPARK PLUG

Tools Required: 13/16-Inch Spark Plug Socket, Spark Plug Gapping Tool, Clean Rag, and Screwdriver

Correct spark plug to use is a Champion RJ18Y or equivalent, and correct air gap is 0.035 (0.889 mm) of an inch. Since air gap between center and side electrodes of the spark plug increases gradually during normal engine operation, check condition of center and side electrodes after every 25 hours of engine operation. If electrodes are deteriorated or plug is fouled, install a new plug.

1. Remove three screws holding front of shroud to impeller housing (Fig. 20).

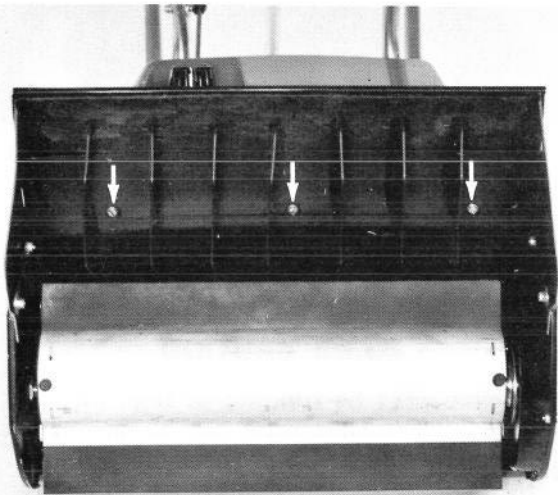

Figure 20

2. Remove cap from snowthrower fuel tank (Fig. 21).

3. Remove two self tapping screws holding sides of upper shroud; then remove shroud (Fig. 21). Reinstall cap on snowthrower fuel tank.

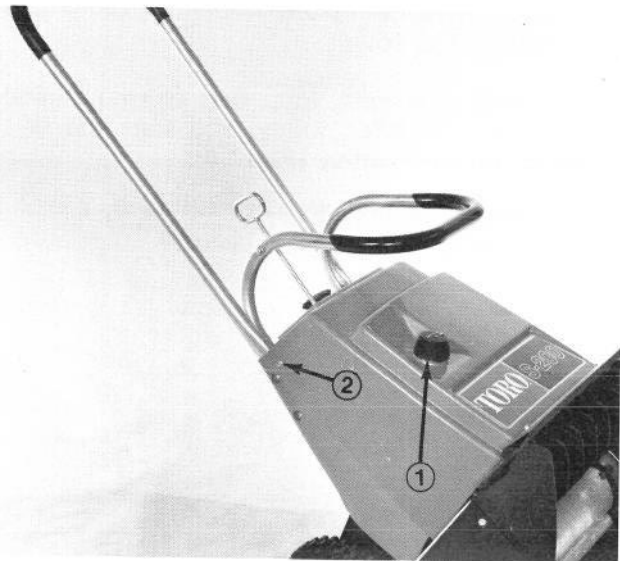

Figure 21

1. Remove cap
2. Shroud mount screw

4. Clean area around spark plug so foreign matter cannot fall into cylinder when plug is removed.

5. Pull high tension wire off spark plug and remove plug from cylinder head (Fig. 22).

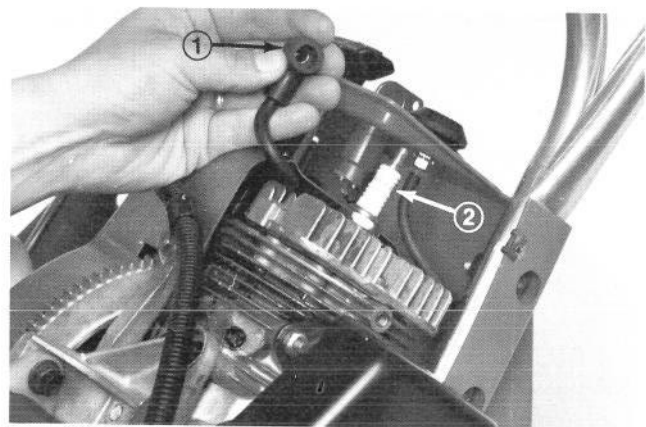

Figure 22

1. High tension wire
2. Spark plug

IMPORTANT: A cracked, fouled, or dirty spark plug must be replaced. Do not sandblast, scrape, or clean electrodes using a wire brush because grit may eventually release from the plug and fall into the cylinder. The result will likely be engine damage. Therefore if condition of plug is doubtful, install a new plug — step 6.

6. Set air gap between electrodes of new spark plug at 0.035 of an inch (0.889 mm) (Fig. 23). Install spark plug in cylinder head and tighten it to 15 ft-lb (20.4 N·m). If torque wrench is not used, tighten plug firmly.

MAINTENANCE

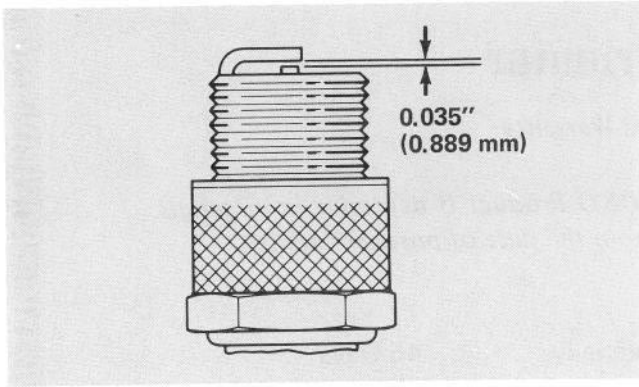

Figure 23

7. Push high tension wire onto spark plug (Fig. 22).
8. Remove cap from snowthrower fuel tank and set upper shroud in place (Fig. 21). Reinstall cap on fuel tank.
9. Secure front of shroud to impeller housing with three $\frac{3}{4}$ inch long (19 mm) screws (Fig. 20).
10. Insert front panel into grooves of upper shroud. Secure sides of upper shroud with two $\frac{1}{2}$ inch (12.7 mm) long self tapping screws (Fig. 21).

PREPARING SNOWTHROWER FOR STORAGE



CAUTION

Because gasoline/oil mixture in snowthrower fuel is explosive, the fuel mixture must be drained outdoors, away from fire or flame. Do not smoke while draining gasoline. If fuel mixture explodes, personal injury may result.

1. Remove cap from snowthrower fuel tank and tip snowthrower upside down so fuel drains into a container. After fuel is drained, install cap on fuel tank. Wipe up any fuel that may have spilled.

2. Start the engine and let engine run until it stops because there is no fuel. When engine sputters, rotate choke clockwise so fuel in carburetor is expended.

Note: After fuel is drained from fuel tank, there may not be enough fuel in the fuel system to start the engine. Nevertheless, fuel must be expended to prevent gum-like varnish deposits from forming in carburetor, fuel line, and fuel tank. Such deposits, if allowed to form, will cause starting problems next snow season. Therefore, if engine will not start, pull recoil starter handle 5 - 10 times to expend all fuel in the system.

3. Remove spark plug from cylinder head: refer to Replacing Spark Plug, steps 1-5, page 14. Next, pour two teaspoons of engine oil into the spark plug hole in the cylinder head. Pull recoil starter slowly to distribute oil on inside of cylinder. Reinstall spark plug in cylinder head and tighten it to 15 ft-lb (20.4 N·m).

4. Clean impeller, impeller housing, and exterior of snowthrower.

5. Tighten all screws and nuts. If any part is damaged, repair or replace it.

6. Store snowthrower in a clean, dry place, and cover it to give protection. Never store snowthrower in the house or basement.

7. Store S200 Electric Start extension cord with the machine so it will not be misplaced.

IDENTIFICATION AND ORDERING

MODEL AND SERIAL NUMBERS

The snowthrower has two identification numbers: a model number and a serial number. The two numbers are stamped on a decal (Fig. 24) which is located on right side of impeller housing, just ahead of the right wheel. In any correspondence concerning the snowthrower, supply model and serial numbers to assure that correct information and replacement parts are obtained.

To order replacement parts from an Authorized TORO Service Dealer, supply the following information:

1. Model and serial numbers of the snowthrower.

2. Part number, description, and quantity of part(s) desired.

Note: Do not order by reference number if a parts catalog is being used; use the PART NUMBER.

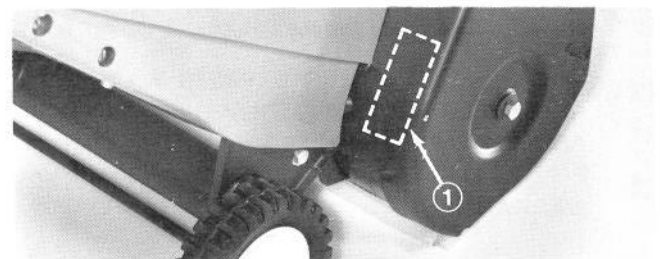

Figure 24

1. Model and serial number

The Toro Promise

A One Year Limited Warranty

The Toro Company promises to repair any TORO Product if defective in materials or workmanship. The following time periods from the date of purchase apply:

Residential Product	1 Year
Residential Products Used Commercially . . .	45 Days

The costs of parts and labor are included, but the customer pays the transportation costs. Just return any residential product to an Authorized TORO Service Dealer or TORO Distributor.

Should you feel your TORO is defective and wish to rely on The Toro Promise, the following procedure is recommended:

1. Contact any Authorized TORO Service Dealer, TORO Master Service Dealer, or TORO Distributor (the Yellow Pages of your telephone directory is a good reference source).
2. He will either instruct you to return the product to him or recommend another Authorized TORO Service outlet which might be more convenient.
3. Bring the product along with your original sales slip, or other evidence of purchase date, to the service dealer.
4. The servicing dealer will inspect the unit, advise you whether the product is defective and, if so, make all repairs necessary to correct the defect without extra charge to you.

If for any reason you are dissatisfied with the dealer's analysis of the defect or the service performed, you may contact us.

Write:

TORO Customer Service Department
8111 Lyndale Avenue South
Minneapolis, Minnesota 55420

The above remedy of product defects through repair by an Authorized TORO Service Dealer is the purchaser's sole remedy for any defect.

THERE IS NO OTHER EXPRESS WARRANTY. ALL IMPLIED WARRANTIES OF MERCHANTABILITY AND FITNESS FOR USE ARE LIMITED TO THE DURATION OF THE EXPRESS WARRANTY.

Some states do not allow limitation on how long implied warranty lasts, so the above limitation may not apply to you.

This Warranty applies only to parts or components which are defective and does not cover repairs necessary due to normal wear, misuse, accidents, or lack of proper maintenance. Regular, routine maintenance of the unit to keep it in proper operating condition is the responsibility of the owner.

All warranty repairs reimbursable under The Toro Promise must be performed by an Authorized TORO Service Dealer using Toro approved replacement parts.

Repairs or attempted repairs by anyone other than an Authorized TORO Service Account are not reimbursable under The Toro Promise. In addition, these unauthorized repair attempts may result in additional malfunctions, the correction of which is not covered by warranty.

The Toro Company is not liable for indirect, incidental or consequential damages in connection with the use of the product including any cost or expense of providing substitute equipment or service during periods of malfunction or non-use.

Some states do not allow the exclusion of incidental or consequential damages, so the above exclusion may not apply to you.

This warranty gives you specific legal rights, and you may also have other rights which vary from state to state.