



GROUNDSMASTER® 220

20 HP

Traction Unit

Model No. 30620 - 790001 & UP

Operator's Manual

IMPORTANT: Read this manual carefully. It contains information about your safety and the safety of others. Also become familiar with the controls and their proper use before you operate the product.

FOREWARD

The GROUNDSMASTER 220 was developed to satisfy the demand for a maneuverable, intermediate size, turf maintenance rotary mower. The machine has advanced concepts in engineering, design and safety; and if maintained properly, it will give excellent service.

Since the GROUNDSMASTER 220 is a high quality product, Toro is concerned about the future use of the machine and the safety of the user. Read this manual to familiarize yourself with the proper set-up, operation, and maintenance instructions. The major sections of this manual are:

1. Safety Instructions
2. Set Up Instructions
3. Before Operating
4. Operating Instructions
5. Maintenance

Certain information in this manual is emphasized. DANGER, WARNING and CAUTION identify personal safety related information. IMPORTANT identifies mechanical information demanding special attention. Be sure to read the directive because it deals with the possibility of damaging a part or parts of the machine. NOTE identifies general information worthy of special attention.

If help concerning set up, operation, maintenance or safety is ever needed, contact a local Authorized Toro Distributor. In addition to genuine Toro replacement parts, the distributor also has optional equipment from the complete line of Toro turf care equipment. Keep your Toro all Toro — buy genuine Toro replacement parts and accessories.

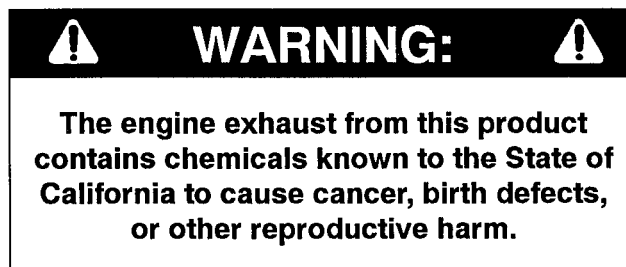

OPTIONAL SPARK ARRESTER MUFFLER

In some areas there are local, state or federal regulations requiring that a spark arrestor muffler be used on the engine of this mower. If a spark arrestor muffler is required, order the following part from you Authorized Toro Distributor.

(1) 46-2390 Spark Arrestor Muffler Assembly

This part is certified to meet the requirements of USDA Forest Service Standard No. 5100-1A. The approval number for the exhaust system is 18731.

When the mower is used or operated on any California forest, brush or grass covered land, a properly operating spark arrester must be attached to the muffler. The operator is violating state law, Section 442 Public Resources Code if a spark arrester is not used.

If help concerning set-up, operation, maintenance or safety is ever needed, contact your local Authorized Toro ProLine Dealer. In addition to genuine TORO replacement parts, the dealer also has optional equipment for the complete line of Toro turf care equipment.

TABLE OF CONTENTS

	PAGE		PAGE
SAFETY INSTRUCTIONS	4	Servicing Air Cleaner Filter	19
SAFETY AND INSTRUCTION DECALS	6	Inspecting Filter Element	20
SPECIFICATIONS	7	ENGINE MAINTENANCE	20
LOOSE PARTS CHART	8	Changing Engine Oil And Filter	20
SET-UP INSTRUCTIONS	8	Cleaning Cylinder head Fins	21
Install Steering Wheel	9	Cleaning Combustion Chamber	21
Installing Seat	9	FUEL SYSTEM MAINTENANCE	22
Check Tire Pressure	10	Adjusting Carburetor	22
BEFORE OPERATING	10	Adjusting Low Speed Idle	23
Connect Battery	10	Adjusting High Speed Idle	23
Check Crankcase Oil	11	Replacing Fuel Filter	23
Check Hydraulic System Fluid	11	ELECTRICAL MAINTENANCE	23
Fill Fuel Tank	12	Checking and Replacing Spark Plugs	23
CONTROLS	13	Servicing Battery	24
OPERATING INSTRUCTIONS	14	Wiring Harness Service	24
Starting and Stopping	14	Adjusting PTO Lever Switch	24
Checking Interlock System	15	WIRING SCHEMATIC	25
Operating Characteristics	15	HYDRAULIC SCHEMATIC MAINTENANCE	25
Pushing Or Towing Traction Unit	16	Adjusting Transmission For Neutral	25
LUBRICATION MAINTENANCE	16	Changing Hydraulic Oil and Filter	26
Greasing Bearings And Bushings	16	PRODUCT IDENTIFICATION	26
BRAKE MAINTENANCE	18	PREPARATION FOR SEASONAL STORAGE ...	27
Adjusting Service Brakes	18	SERVICE INTERVAL CHART AND SERVICE	
AIR CLEANER MAINTENANCE	19	SPECIFICATIONS	28
General Maintenance Practices	19	THE TORO PROMISE	Back Cover
Servicing Dust Cup and Baffle	19		
SERVICE INTERVAL CHART	20		
DAILY MAINTENANCE CHECK LIST	21		

THE ENCLOSED ENGINE OWNER'S MANUAL IS SUPPLIED FOR CALIFORNIA EMISSION CONTROL REGULATION INFORMATION ON EMISSION SYSTEMS, MAINTENANCE AND WARRANTY.

KEEP THIS ENGINE OWNER'S MANUAL WITH YOUR UNIT. SHOULD THIS ENGINE OWNER'S MANUAL BECOME DAMAGED OR ILLEGIBLE, REPLACE IMMEDIATELY. REPLACEMENTS MAY BE ORDERED THROUGH THE ENGINE MANUFACTURER.



SAFETY INSTRUCTIONS

This machine meets or exceeds the B71.4-1990 specifications of the American National Standards Institute. However, improper use or maintenance by the operator or owner can result in injury. To reduce the potential for injury, comply with these safety instructions and always pay attention to the safety alert  symbol, which means CAUTION, WARNING or DANGER—"personal safety instruction." Failure to comply with the instruction may result in personal injury.

WARNING: Engine exhaust contains carbon monoxide which is an odorless, deadly poison. Carbon monoxide is also known to the State of California to cause birth defects. Do not run engine indoors or in an enclosed area without adequate ventilation.

BEFORE OPERATING

1. Read, understand and follow the instructions in this Operator's Manual and on the machine before starting. Become familiar with all controls and know how to stop the machine and engine quickly. A replacement manual is available by sending complete model and serial number to:

The Toro Company
8111 Lyndale Avenue South
Bloomington, Minnesota 55420-1196
Attn: Technical Publications

2. Never allow children to operate the machine. Do not allow adults to operate machine without proper instruction. Only trained operators who have read this manual should operate this machine.

3. Never operate the machine when under the influence of drugs or alcohol.

4. Remove all debris or other objects that might be picked up and thrown by the blades or fast moving components from other attachments. Keep all bystanders away from operating area.

5. Do not operate machine unless all shields, guards, covers and safety devices are in place. If a shield, guard, safety device or decal is illegible or damaged, repair or replace it before operating the machine.

6. Do not operate machine while wearing sandals, tennis shoes, sneakers or shorts. Also do not wear loose fitting clothing that could get caught in moving parts and possibly cause personal injury. Always wear long pants and substantial shoes. Wearing safety glasses, safety shoes, and a helmet is advisable and required by some local ordinances and insurance regulations.

7. Check interlock switches daily for proper operation (Refer To Checking Interlock Switches, Page 15). Do not rely entirely on safety switches -shut off engine before getting off seat. If a switch fails, replace it before operating the machine. The interlock system is for your protection, so do not bypass it. Replace all interlock switches every two years. Interlock switches should be adjusted so:

- A. Engine cannot be started unless traction pedal is released (neutral position)—and PTO lever is DISENGAGED (off position).
- B. Engine stops if operator gets off seat when traction pedal is depressed.
- C. Engine stops if operator gets off seat when PTO lever is ENGAGED (on position).

8. Grass deflectors must be installed in lowest position on side discharge units.

9. Since gasoline is highly flammable, handle it carefully:

- A. Use an approved fuel container.
- B. Never remove fuel cap or add fuel when the engine is running. Allow the engine to cool before refueling. Do not smoke.
- C. Never refuel the machine indoors.
- D. Keep hood closed when refueling
- E. Fill fuel tank outdoors and only to within an inch from the top of the tank, not the filler neck. Do not overfill.

WHILE OPERATING

10. Never carry passengers.

11. Traverse slopes carefully. Do not start or stop suddenly when traveling uphill or downhill.

12. Operator must be skilled and trained in how to drive on hillsides. Failure to use caution on slopes or hills may cause loss of control and vehicle to tip or roll possibly resulting in personal injury or death.

13. Using the machine demands attention, and to prevent loss of control:

- A. Mow only in daylight or when there is good artificial light.
- B. Watch for holes or other hidden hazards.
- C. Do not drive close to a sand trap, ditch, creek or other hazard.
- D. Reduce speed when making sharp turns.
- E. Avoid sudden stops and starts.
- F. Cut slopes carefully. Do not start or stop, or turn on a hillsides.
- G. Before backing up, look to the rear and assure no one is behind machine.
- H. Watch out for traffic when near or crossing roads. Always yield the right-of-way.



SAFETY INSTRUCTIONS

14. If engine stalls or loses headway and cannot make it to the top of a slope, do not turn machine around. Always back slowly straight down the slope.

15. Do not operate unless grass deflector, Recycler cover or entire grass collector is installed. The grass deflector must always be installed and in the lowest position on the side discharge cutting unit. This product is designed to drive objects into the ground where they lose energy quickly in grassy areas. **HOWEVER DON'T TAKE AN INJURY RISK!** When a person or pet appears unexpectedly in or near the mowing area, **STOP MOWING**. Careless operation, combined with terrain angles, ricochets, or improperly positioned guards, can lead to thrown object injuries. Do not resume mowing until area is cleared.

16. Never raise the cutting unit or other attached implement while the blades or other parts are rotating.

17. If cutting blade(s) strikes a solid object or the machine vibrates abnormally, stop immediately, turn engine off, set parking brake and wait for all motion to stop. Inspect for damage. If damaged, repair or replace any components before operating.

18. Do not touch engine, muffler or exhaust pipe while engine is running or soon after it is stopped. These areas could be hot enough to cause burns.

19. Never leave a running machine unattended. Always turn off blades, set parking brake, stop engine and remove key before dismounting.

20. Do not run engine in a confined area without adequate ventilation. Exhaust fumes are hazardous and could possibly be deadly.

21. This product may exceed noise levels of 85 dB(A) at the operator position. Ear protectors are recommended for prolonged exposure to reduce the potential of permanent hearing damage.

MAINTENANCE

22. Remove key from ignition switch and disconnect spark plug wire(s) to prevent accidental starting of the engine when servicing, adjusting or storing the machine.

23. Be sure machine is in safe operating condition by keeping all nuts, bolts and screws tight. Check the

blade mounting molts and nuts frequently to be sure they are tightened to specifications.

24. To reduce potential fire hazard, keep the engine free of excessive grease, grass, leaves and accumulated dirt.

25. Make sure all hydraulic line connectors are tight, and all hydraulic hoses and lines are in good condition before applying pressure to the system.

26. Keep body and hands away from pin hole leaks or nozzles that eject high pressure hydraulic fluid. Use cardboard or paper to find hydraulic leaks. Hydraulic fluid escaping under pressure can penetrate skin and cause injury. Fluid accidentally injected into the skin must be surgically removed within a few hours by a doctor familiar with this form of injury or gangrene may result.

27. Before disconnecting or performing any work on the hydraulic system, all pressure in system must be relieved by stopping engine and lowering implement to the ground.

28. If engine must be running to perform maintenance or an adjustment, keep hands, feet, clothing and other parts of the body away from cutting unit blades and other moving parts. Keep all bystanders away.

29. Do not overspeed the engine by changing governor setting. To assure safety and accuracy, have an Authorized Toro Distributor check maximum engine speed.

30. Allow engine to cool before storing mower in any enclosure such as a garage or storage shed. Make sure the mower fuel tank is empty if the machine is to be stored in excess of 30 days. Do not store mower near any open flame or where gasoline fumes may be ignited by a spark. Always store gasoline in a safety-approved red metal container.

31. At the time of manufacture, the machine conformed to the safety standards for commercial riding mowers. Therefore to assure optimum performance and continued safety certification, always use genuine Toro replacement parts and accessories. Replacement parts and accessories made by other manufacturers may result in non-conformance with the safety standards, and could void the warranty.



SAFETY AND INSTRUCTION DECALS

The following safety and instruction decals are affixed to the traction unit. If any decal becomes illegible or damaged, replace it. The decal part numbers are listed below and in your Parts Catalog. Replacements can be ordered from your Authorized TORO ProLine Dealer.

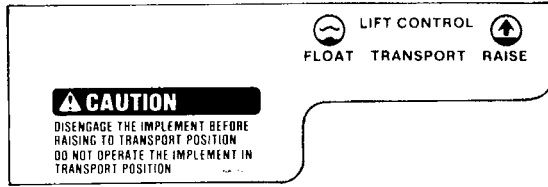

AROUND LIFT CONTROL LEVER
(Part No. 68-7320)



ALONGSIDE FUEL TANK
(Part No. 27-7310)

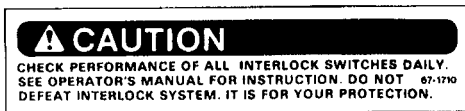

FORWARD OF LIFT LEVER
(Part No. 67-1710)



ON GAS TANK
(Part No. 43-8480)

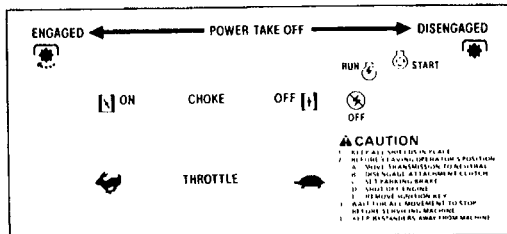

CONTROL PANEL
(Part No. 68-7350)

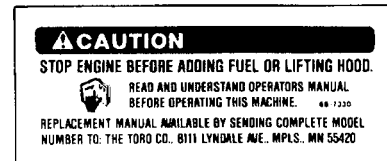

LEFT SIDE OF SEAT
(Part No. 68-7330)

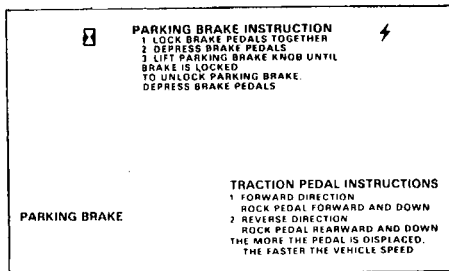

AROUND STEERING COLUMN
(Part No. 41-8910)

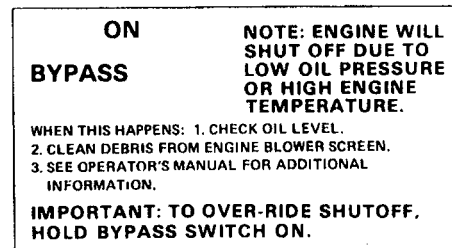

FRONT CONTROL PANEL
(Part No. 46-3460)

SPECIFICATIONS

Engine:

Manufacturer — Onan
Horsepower — 20 (14.9 kw) @ 3600 RPM.
Torque — 32 lb-ft (43.3 N-m) @ 2700 RPM.
Displacement — 47.7 cu. in. (782 cc).
Crankcase Capacity — 1.8 qt (1.7 l).
Governor — Mechanical.
Governor Limit — 3100-3300 RPM.
Idle Speed — 1500 RPM.
Spark Plug — Champion RS14YC
Air Gap — 0.025 in. (0.64 mm).
Ignition — Solid State Electronic.

Air Cleaner: Donaldson heavy duty with precleaner. Remote mounted.

Fuel Tank Capacity: 6 gal (22.7 l).

Electrical: Battery — 12 volt, 42 plate, 300 CCA. 20 amp alternator with regulator/rectifier.

Drive Coupling: Transmission driven by steel shaft with flexible rubber couplings at each end.

Transmission:

Manufacturer & Type — Sundstrand Hydrostatic, Type U.
Normal Charge Pressure — 70-150 psi (483-1034 kPa).
Implement Relief Setting — 700-800 psi (4 826 - 5 516 kPa).

Hydraulic Filter: 25 micron mounted directly to transmission. Replaceable (Toro Part No. 23-2300).

Drive Axle: Manufacturer — Dana Corp., Model GT-20. Used as hydraulic reservoir with approx. 5 qt (5.7 l) capacity. Mates directly with transmission.

Brakes: Mechanical drum type, 7 in. (17.8 cm) dia. x 1-3/4 in. (45 mm) wide. Individually controlled by two pedals connected by cable and conduit for steering assist. Pedals may be latched together for two wheel braking. Lever provided for parking brake.

Tires, Wheels, Pressure:

Wheels — demountable type.
Front Tires — 20 x 8.00 x 10.
Rear Tires — 15 x 6.00 x 6.
All tires 4 ply rating, tubeless type.
(Pressure — 10-15 psi (69-103 kPa)).

Steering: 15 in. (38 cm) steering wheel. Saginaw Automotive steering gear assembly.

Main Frame: Frame is welded, formed steel, reinforced with square tubing.

Gauges: Hour meter and ammeter are mounted on steering tower console.

Controls: Throttle, choke, PTO lever, parking brake, implement lift, ignition switch, and low oil pressure or

high cylinder head temperature by-pass switch are all hand-operated. Traction pedal and brakes are foot operated.

PTO Drive: 1 in. (25 mm) diameter, splined PTO shaft is driven by HA Section Torque Team tight-slack V-belt directly from engine output shaft. PTO shaft clutched by pivoting PTO shaft support with spring loaded, over-center hand operated lever. PTO speed — 2269 RPM @ 3300 RPM engine speed.

Implement Connection — Weasler universal joint and telescoping shaft assembly.

Lift Cylinders: Two, with 1-1/2 in. (38 mm) bore, 4 in. (102 mm) stroke.

Lift Arms: High strength low alloy channel welded to a high strength elbow plate with a front mounting bar for the bolt on carriage frame. The lift arms stay on the traction unit for ease of interchangeability with other decks or attachments and are actuated by the hydraulic cylinders.

Control Valve: Equipped with load check valves to prevent settling of implement.

Interlock Switches: Prevents engine starting if traction pedal or PTO levers are engaged. Stops engine if operator leaves seat with either traction pedal or PTO levers engaged.

Dimensions and Weight (approx):

Traction Unit	Length:	78 in. (19.6 cm)
w/Standard	Width:	42 in. (10.7 cm)
Seat	Height:	48 in. (12.2 cm)
	Weight:	825 lb

OPTIONAL EQUIPMENT:

52" Cutting Unit — Model No. 30652

62" Cutting Unit — Model No. 30662

Recycler Kit — Model 59225 — Use with Model 30662 Cutting Unit.

Mulcher Kit — Model No. 30792. Use with Model 30662 Cutting Unit.

Mulcher Kit — Model No. 30700. Use with Model 30652 Cutting Unit.

Grass Collection System — Order Separately:

Blower Kit

— Model 30502 for 52" Cutting Unit Model No. 30652

— Model No. 30503 for 62" Cutting Unit Model No. 30662

Hopper Kit

— Model No. 30504 for 52" & 62" Cutting Units Model Nos. 30652 and 30662.

48 in. (1.219 m) V-Plow — Model No. 30750

V-Plow Mounting Kit — Model No. 30749 (Required for mounting V-Plow). Consists of push arm attaching brackets and tire chains.

SPECIFICATIONS

Wheel Weight — Model No. 30762. 100lb (45.4 kg).

Spark Arrestor Muffler— Part No. 46–2390.

Rear Weight Kit — Part No. 24–5790. 35lb (15.6kg).

Deluxe Seat Kit — Model No. 30705

Tire Chains — Part No. 28–5470

LOOSE PARTS

NOTE: Use this chart as a checklist to assure all parts have been received. Without these parts, total set–up cannot be completed.

DESCRIPTION	QTY.	USE
Steering Wheel	1	Install Steering Wheel.
Roll Pin 1/4 x 2 in.	1	
Seat	1	Install seat.
“U” Spring	2	
Seat Mounting Bracket	2	
Plastic Spacers	4	
Capscrew	8	
Lockwasher	8	
Nut	8	
Shoulder Blot	2	
Flat Washer	2	
Adjustment Handle	2	
Washer	2	
Locknut	2	
Manual Tube	1	
R–Clamp	2	
Roll Pin	1	Secure universal shaft to implement.
Return Spring	2	Use to mount cutting unit.
Operator’s Manual (Traction Unit)	2	Fill out and return to Toro
Parts Catalog	1	
Registration Card	1	
Set-up Report Card	1	

SET-UP INSTRUCTIONS



WARNING

PTO universal shaft is attached to traction unit. **DO NOT ENGAGE PTO** without first removing universal shaft or coupling it to a suitable implement.

INSTALL STEERING WHEEL

1. Move rear wheels so they point straight ahead.
2. Slide steering wheel onto steering shaft aligning mounting holes (Fig. 1).
3. Secure steering wheel in place with roll pin (Fig. 1).

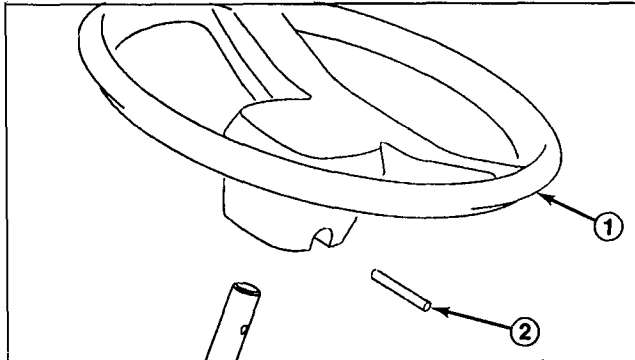

Figure 1

1. Steering wheel
2. Roll pin

INSTALLING SEAT

1. Attach "U" springs to seat mounting brackets using bolts and locknut as shown in (Fig. 2).

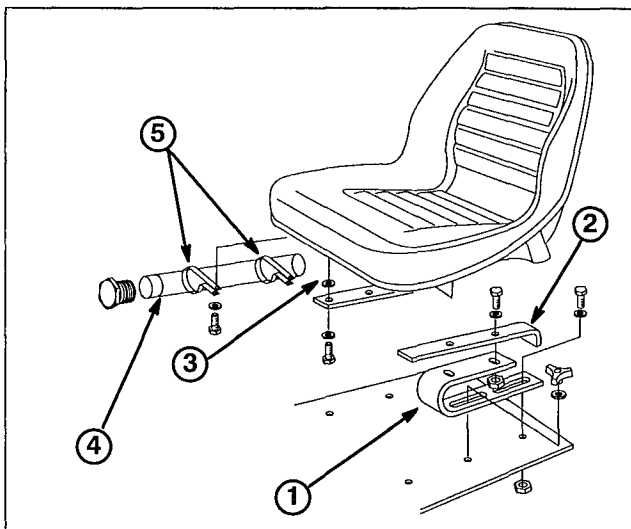

Figure 2

1. "U" spring
2. Seat mounting bracket
3. Plastic Spacer
4. Manual Tube
5. R-clamp

2. Install lockwashers and R-Clamps onto each mounting capscrew for the right seat mount. Insert the assemblies through the seat bracket holes and secure the bracket to the seat (Fig. 2). Install lockwashers onto each mounting capscrew for the left seat bracket and secure the bracket to the seat. Install manual tube into R-Clamps.

Note: Mount the bracket in the forward set of tapped mounting holes in seat.

3. Mount seat and spring assembly to rear holes in traction unit mount plate with two shoulder bolts, flat washers and locknuts (Fig. 3).
4. Secure front slots of seat springs to mount plate with adjustment handles and flatwashers (Fig. 3).

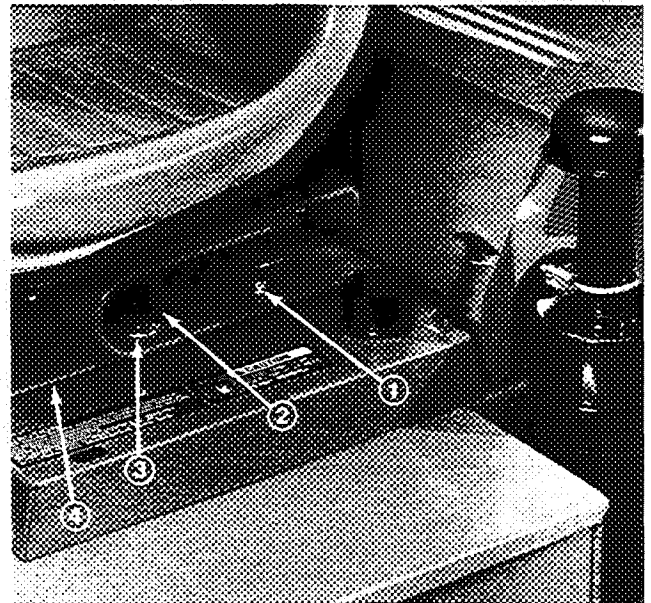

Figure 3

1. Shoulder bolt, flat washer, locknut
2. Adjustment handle
3. Flat washer
4. Mount plate

Note: Be sure to use flatwashers with small I.D.

5. When seat is adjusted to desirable position, tighten all fasteners.

Optional Seat kit, Model No. 30705, Deluxe Seat:

1. Mount seat mounting plate over four threaded studs at the bottom of seat suspension assembly and secure in place with lockwashers and nuts (Fig. 4).
2. Assemble seat suspension assembly to four capscrews on seat bottom and install a lockwasher and flatwasher at all four locations. Install and R-clamp over right front and right rear capscrews of seat and

SET-UP INSTRUCTIONS

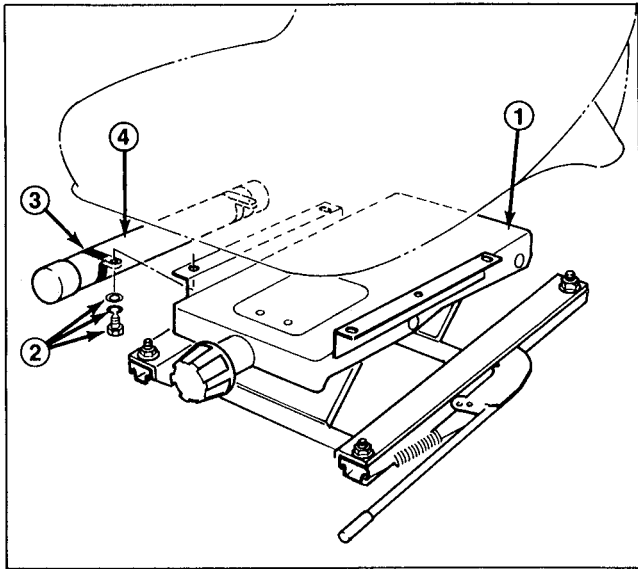

Figure 4

- | | |
|--|-------------------------|
| 1. Adjustable suspension unit | 3. R-clamp (2) |
| 2. Capscrew, lockwasher and flatwasher | 4. Manual tube and caps |

install and tighten nuts to secure all four locations (Fig. 4). Install manual tube into R-clamps.

3. Mount seat support over four threaded studs at the bottom of seat suspension assembly and secure in place with lockwashers and nuts (Fig. 5).

4. Adjust seat for operator's comfort and weight. To adjust seat fore and aft, pull handle on left side of seat assembly outward. Release handle to lock seat position. To adjust for operator's weight, turn spring ten-

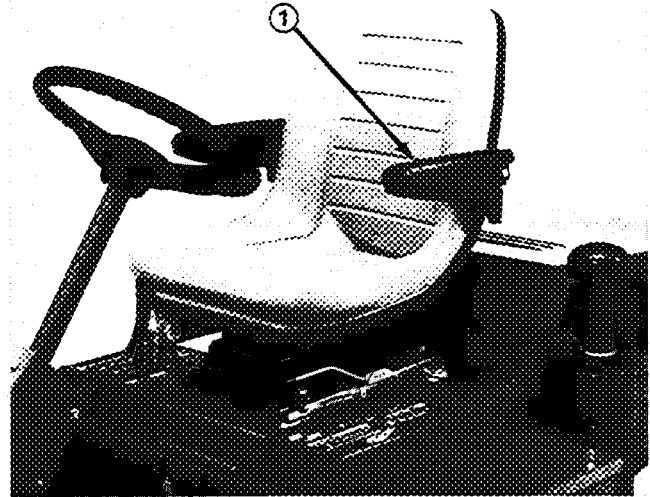

Figure 5

1. Arm rest

sion knob; clockwise to increase tension, counter-clockwise to decrease spring tension.

5. Install arm rests to sides of seat with capscrews supplied with kit (Fig.5).

CHECK TIRE PRESSURE

The tires are over-inflated for shipping. Therefore, release some of the air to reduce the pressure. Correct air pressure in front and rear tires is 10 to 15 psi (68.9 to 103.4 Kpa).

BEFORE OPERATING

CONNECT BATTERY

1. Loosen capscrew securing battery cover and open cover (Fig. 6).

2. Slide battery partially out of battery compartment until terminals are accessible (Fig. 7).

3. Connect the positive battery cable (red) to the positive post (+) of the battery. Secure with wrench, coat terminal with petroleum jelly and slide boot over terminal.

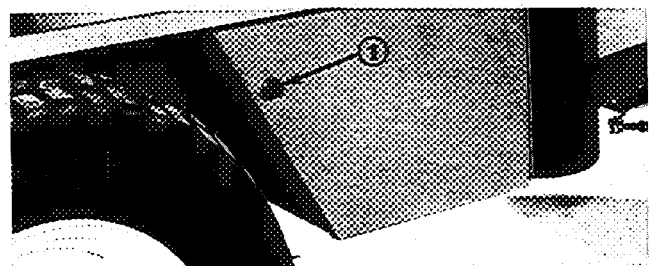

Figure 6

1. Battery cover capscrew

BEFORE OPERATING

4. Connect the black ground cable to the negative (–) post of battery. Secure with wrench, coat terminal with petroleum jelly.
5. Slide battery back into battery compartment and secure cover.

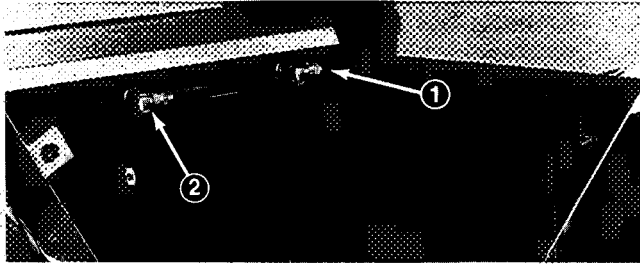

Figure 7

1. Negative battery cable
2. Positive battery cable

CHECK CRANKCASE OIL

The Onan engine is shipped with 1.8 qt (1.70 l) of oil in the crankcase; however, level of oil must be checked before and after the engine is first started.

1. Position machine on a level surface.
2. Disengage hood latches and open the hood.
3. Unscrew dipstick and wipe it with a clean rag. Screw dipstick into the filler neck and make sure it is seated fully. Unscrew dipstick out of filler neck and check level of oil (Fig. 8). If oil level is low, add enough oil to raise level to FULL mark on dipstick.

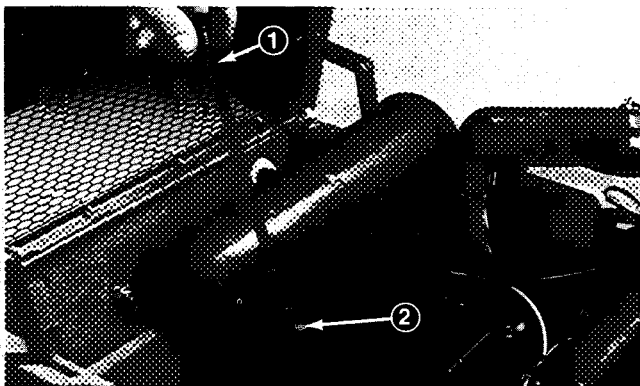

Figure 8

1. Dipstick
2. Filler neck

Note: If level of oil is at the ADD mark on the dipstick, add 1 pint (0.47 l) of oil to raise level to FULL. Do not overfill.

4. Pour oil into filler neck until level is at the FULL mark on dipstick. The Onan engine uses any high-quality detergent oil having the American

Petroleum Institute — API — “service classification” SF. Oil viscosity — weight — must be selected according to anticipated ambient temperature (Fig. 9). Refer to temperature/viscosity recommendations.

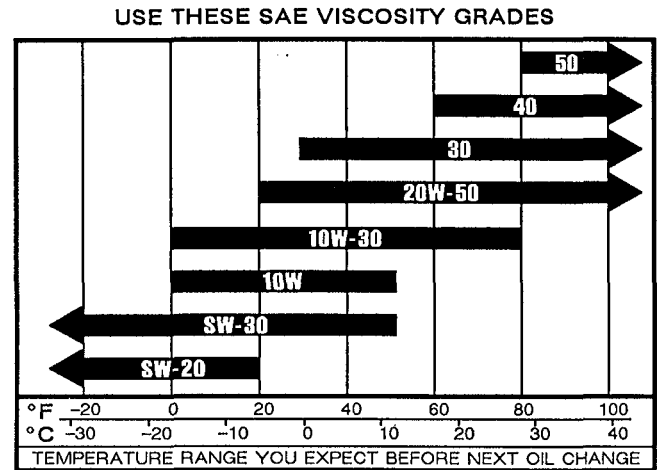

Figure 9

IMPORTANT: Check level of oil every 8 operating hours or daily. Initially, change oil after the first 25 hours of operation; thereafter, under normal conditions, change oil after every 50 hours of operation. However, change oil more frequently when engine is operated in extremely dusty or dirty conditions.

5. Since pressure in the crankcase operates the fuel pump, make sure dipstick is seated tightly in the filler neck. If the dipstick and filler neck do not seal, the fuel pump may not function properly. Furthermore, the engine will use excessive amounts of oil. Therefore, be sure dipstick is seated in oil filler neck.

CHECK HYDRAULIC SYSTEM FLUID

The hydraulic system is designed to operate on any high quality detergent oil having the American Petroleum Institute — API — “service classification” SF/CC or CD. Oil viscosity — weight — must be selected according to anticipated ambient temperature for the season in which product will be used.

Temperature/viscosity recommendations are:

Expected Ambient Temperature	Recommended Viscosity and Type
(Extreme) over 90°F	SAE 30, Type SF/CC or CD engine oil.
(Normal) 40-100°F	SAE 10W-30 or 10W-40, Type SF/CC or CD engine oil.
(Cool — Spring/Fall) 30-50°F	SAE 5W-30, Type SF/CC or CD engine oil.

BEFORE OPERATING

(Winter) Below 30°F Type "F" or "FA" ATF Automatic Transmission Fluid. **DO NOT USE DEXTRON II ATF.**

Note: Do not mix engine oil and automatic transmission fluid or hydraulic system component damage may result. When changing fluids, completely drain system and change transmission filter.

1. Position machine on a level surface, raise the cutting unit and stop the engine.
2. Remove dipstick cap (Fig. 10) from filler neck and wipe it with a clean rag. Screw dipstick cap finger-tight onto filler neck; then remove it and check level of fluid. If level is not within 1/2 inch (13 mm) from the groove in the dipstick (Fig. 10), add fluid to raise level to groove mark. Do not overfill. Use proper SAE weight oil or transmission fluid that is in hydraulic system.

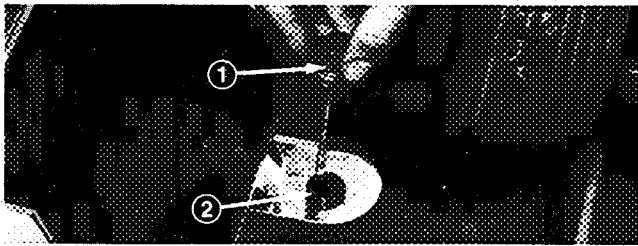

Figure 10

1. Dipstick
2. Filler neck

IMPORTANT: When adding engine oil/transmission fluid to the hydraulic system, use a funnel with a fine wire screen — 200 mesh or finer — and make sure funnel and engine oil/transmission fluid are immaculately clean. This procedure prevents accidental contamination of the hydraulic system.

3. Thread dipstick filler cap finger-tight onto filler neck. It is not necessary to tighten cap with a wrench.

FILL FUEL TANK WITH GASOLINE

THE TORO COMPANY STRONGLY RECOMMENDS THE USE OF CLEAN, FRESH **UNLEADED** REGULAR GASOLINE IN TORO GASOLINE POWERED PRODUCTS. UNLEADED GASOLINE BURNS CLEANER, EXTENDS ENGINE LIFE, AND PROMOTES GOOD STARTING BY REDUCING THE BUILD-UP OF COMBUSTION CHAMBER DEPOSITS. LEADED GASOLINE CAN BE USED IF UNLEADED IS NOT AVAILABLE.

NOTE: NEVER USE METHANOL, GASOLINE CONTAINING METHANOL, GASOLINE CONTAINING MORE THAN 10% ETHANOL, GASOLINE ADDITIVES, GASOLINE DE-ICERS, PREMIUM GASOLINE, OR WHITE GAS BECAUSE ENGINE FUEL SYSTEM DAMAGE COULD RESULT.



DANGER

Because gasoline is flammable, caution must be used when storing or handling it. Do not fill fuel tank while engine is running, hot or when machine is in an enclosed area. Vapors may build up and be ignited by a spark or flame source many feet away. **DO NOT SMOKE** while filling the fuel tank to prevent the possibility of an explosion. Always fill fuel tank outside and wipe up any spilled gasoline before starting engine. Use a funnel or spout to prevent spilling gasoline before starting engine and fill tank to about 1 inch (25 mm) from the top of the tank (bottom of filler neck). Store gasoline in a clean safety-approved container and keep the cap in place on the container. Keep gasoline in a cool, well-ventilated place; never in an enclosed area such as a hot storage shed. To assure volatility, do not buy more than a 30 day supply of gasoline. Gasoline is a fuel for internal combustion engines; therefore, do not use it for any other purpose. Since many children like the smell of gas, keep it out of their reach because the fumes are explosive and dangerous to inhale.

1. Tip seat forward and prop it so it cannot fall accidentally. Using a clean rag, clean area around fuel tank cap (Fig. 11).

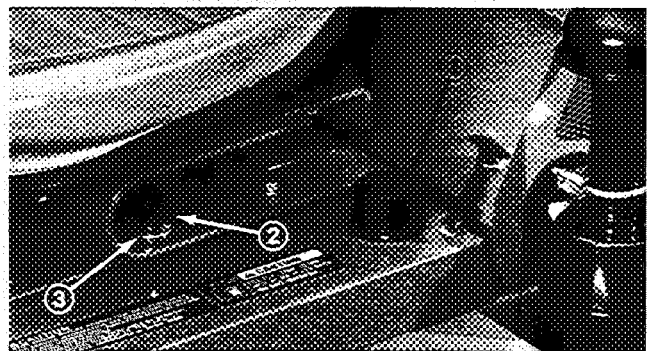

Figure 11

1. Fuel tank cap
2. Adjustment handle
3. Washer

2. Remove cap from the fuel tank and fill the 6 gallon (22.7 l) tank to within 1 inch (25 mm) from the top of the tank (bottom of filler neck) with gasoline. Install fuel tank cap tightly.

3. Wipe up gasoline that may have spilled to prevent a fire hazard. Remove support from under seat and allow seat to pivot back to its normal position.

CONTROLS

Parking Brake (Fig. 12) — Whenever the engine is shut off, the parking brake must be engaged to prevent accidental movement of the machine. To engage the parking brake, push lock arm (Fig. 13) on right brake pedal between the left brake and its lock tab. Next, push down fully on both pedals and pull parking brake knob out; then release the pedals. To release parking brake, depress both pedals until parking brake knob retracts. Before starting the engine, however, lock arm may be disengaged from left brake pedal so both pedals work independently with each front wheel.

Hour Meter (Fig. 12) — The hourmeter registers accumulated hours of engine operation. Use the hourmeter to determine intervals for service maintenance and lubrication.

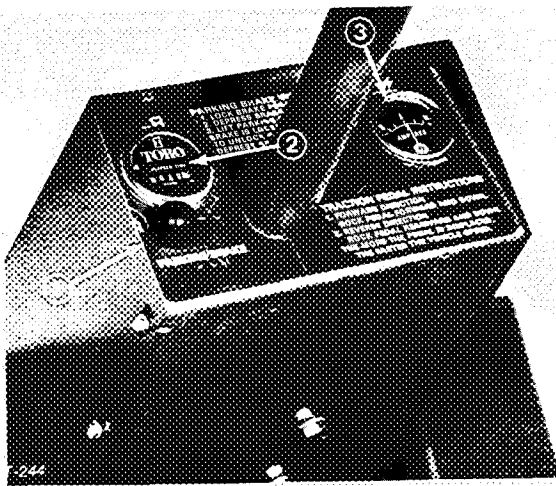

Figure 12

1. Parking brake
2. Hour meter
3. Ammeter

Ammeter (Fig. 12) — Ammeter shows charge rate of the battery by the alternator. When engine is running, there must always be a slight charge, unless engine is idling slowly. Needle will point to 0 when battery is fully charged. By contrast, alternator is not charging the battery when needle points to (—) negative side of ammeter. If this happens, repair the charging system to prevent discharge of the battery.

Service Brakes (Fig. 13) — The left and right brake pedals are connected to the left and right front wheels. Since both brakes work independently of each other, the brakes can be used to turn sharply or to increase traction if one wheel tends to slip while operating on certain slope conditions. However, wet grass or soft turf could be damaged when brakes are used to turn sharply. To make a “quick-stop”, depress both brake pedals together. Do not “quick-stop” with deck in transport position.

Traction Pedal (Fig. 13) — Traction pedal has two functions: one, to make the machine move forward, the other, to make it move rearward. Using the heel

and toe of the right foot, depress top of pedal to move forward and bottom of pedal to move rearward. Ground speed is proportionate to how far pedal is depressed. For maximum ground speed with no load, traction pedal must be fully depressed while throttle is in FAST position. Maximum speed forward is 8.5 mph (13.7 Km/hr) (approx), 4 mph (6.4 Km/hr) (approx) in reverse. To get maximum power under heavy load or when ascending a hill, have throttle in FAST position while depressing traction pedal slightly to keep engine rpm high. When engine rpm begins to decrease, release traction pedal slightly to allow rpm to increase.

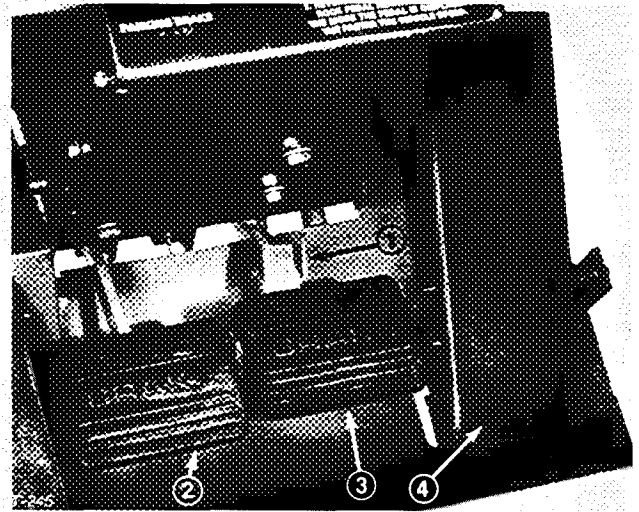

Figure 13

1. Lock arm
2. Left brake
3. Right brake
4. Traction pedal

PTO Lever (Fig. 14) — The PTO lever has two positions: ENGAGE and DISENGAGE. Push PTO lever fully forward to ENGAGE position to start the cutting unit blades. Pull lever rearward to DISENGAGE position to stop the blades. The only time PTO lever should be in the ENGAGE position is when cutting unit is on the turf and grass is actually being mowed.

Ignition Switch (Fig. 14) — The ignition switch, used to start and stop the engine, has three positions: OFF, RUN and START. Rotate key clockwise — START position — to engage starter motor. Release key when engine starts. The key will move automatically to the ON position. To shut engine off, rotate key counter-clockwise to the OFF position.

Low Oil Pressure or High Cylinder Head Temperature By-Pass Switch (Fig. 14) — Overrides engine Low Oil Pressure or High Cylinder Head Temperature shut off switches and allows engine to be operated when switch is held in on position. Avoid prolonged operation of engine using by-pass switch as engine damage may occur.

CONTROLS

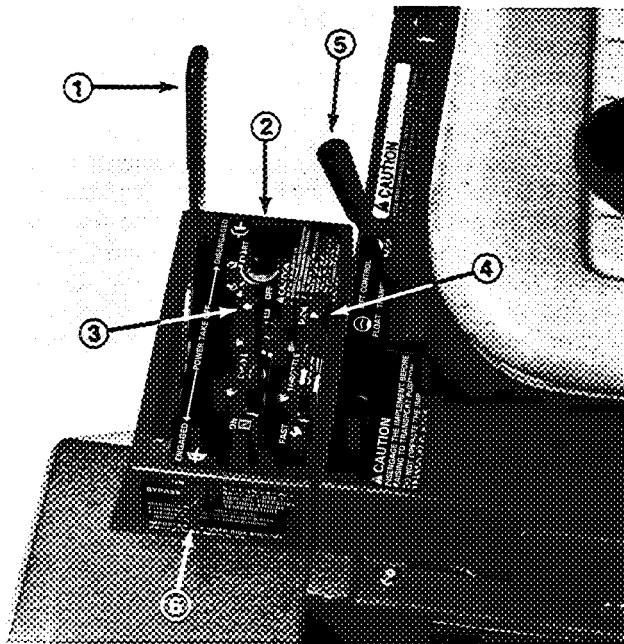

Figure 14

- | | | |
|--------------------|-------------|-------------------|
| 1. PTO lever | 3. Choke | 5. Lift lever |
| 2. Ignition switch | 4. Throttle | 6. By-pass switch |

Choke (Fig. 14) — To start a cold engine, close carburetor choke by moving choke control forward to the ON position. After engine starts, regulate choke to keep engine running smoothly. As soon as possible, open the choke by pulling it rearward to the OFF position. A warm engine requires little or no choking.

Throttle (Fig. 14) — Throttle is used to operate engine at various speeds. Moving throttle forward

increases engine speed — FAST; rearward decreases engine speed — SLOW. The throttle controls the speed of the cutter blades and, in conjunction with traction pedal, controls ground speed of the engine.

Hydraulic Lift Lever (Fig. 14) — The hydraulic lift lever has three positions: FLOAT, TRANSPORT and RAISE. To lower cutting unit to the ground, move lift lever forward into notch in seat cover — FLOAT. The FLOAT position is used for mowing and when machine is not in operation. To raise cutting unit, pull lift lever rearward to the RAISE position. After cutting unit is raised, allow lift lever to move to the TRANSPORT position. Cutting unit must be raised when driving from one work area to another.



CAUTION

Never raise cutting unit while blades are rotating because it is hazardous.

Seat Adjusting Handle — Standard Seat (Fig. 11) — To adjust seat, loosen adjusting handle and slide seat to desired position. Tighten handle to lock seat in place.

Seat Adjusting Handle — Deluxe Seat (Not Shown) — To adjust seat, move lever on left side outward, slide seat to desired position and release lever so it will lock in track.

OPERATING INSTRUCTIONS



DANGER

Do not start the engine and engage the PTO lever when PTO shaft is not connected to cutting unit gear box because the PTO shaft will rotate with enough force to cause serious injury.

STARTING/STOPPING ENGINE

1. Be sure parking brake is set, PTO lever is in DISENGAGE position and lift lever is in TRANSPORT position.
2. Remove foot from traction pedal and make sure pedal is in neutral position.

3. Move choke lever to ON position — when starting a cold engine — and throttle lever to half throttle position.

4. Insert key into ignition switch and rotate it clockwise to start the engine. Release key when engine starts. Regulate the choke to keep engine running smoothly.

IMPORTANT: To prevent overheating of the starter motor, do not engage starter longer than 30 seconds. After 30 seconds of continuous cranking, wait 2 minutes before engaging starter motor again.

5. When engine is started for the first time, or after overhaul of the engine, transmission or axle, operate the machine in forward and reverse for one to two minutes. Also operate the lift lever and PTO lever to be sure of proper operation of all parts.

OPERATING INSTRUCTIONS

Turn steering wheel to the left and right to check steering response. Then shut engine off and check for oil leaks, loose parts and any other noticeable malfunctions.



CAUTION

Shut engine off and wait for all moving parts to stop before checking for oil leaks, loose parts and other malfunctions.

6. To stop the engine, move throttle control rearward to SLOW position, move PTO lever to DISENGAGE and rotate ignition key to OFF. Remove key from switch to prevent accidental starting.

CHECKING OPERATION OF INTERLOCK SWITCHES

The purpose of the safety interlock system is to prevent the engine from cranking or starting unless the operator is on the seat, the traction pedal is in neutral and the PTO control lever is in the DISENGAGE position. In addition, the engine will stop if the operator gets off the seat when the PTO control is engaged or traction pedal is depressed.



CAUTION

Do not disconnect the safety switches because they are for the operator's protection. Check operation of the switches daily to be sure the interlock system is operating correctly. If a switch is malfunctioning, replace it before operating the machine. Replace the switches every 2 years to be sure of maximum safety.

Before checking operating of the interlock switches, locate the machine in an area large enough for maneuverability and which is free of bystanders. Be sure to fully lower the cutting unit or implement and set the parking brake before beginning.

1. Move PTO lever to disengage position and remove foot from traction pedal so it is fully released.
2. Rotate the ignition key to START. Engine should crank. If engine cranks, proceed to step 3. If engine does not crank, there may be a malfunction in the interlock system.
3. Raise off the seat and engage the PTO lever while

the engine is running. The engine should stop. If engine stops, the switch is operating correctly; thus, proceed to step 4. If engine does not stop, there is a malfunction in the interlock system.

4. Raise off the seat and depress the traction pedal while engine is running and PTO lever is disengaged. The engine should stop. If engine stops the switch is operating correctly; thus, continue operation. If engine does not stop, there is a malfunction in the interlock system.

OPERATING CHARACTERISTICS

Practice driving the PROLINE® 220 before initial operation because it has a hydrostatic transmission and its characteristics are different than some turf maintenance machines. Some points to consider when operating the traction unit and cutting unit are the transmission, engine speed, load on the cutting blades, and the importance of the brakes.

To maintain enough power for the traction unit and cutting unit while mowing, regulate traction pedal to keep engine rpm high and somewhat constant. A good rule to follow is: decrease ground speed as the load on the cutting blades increases; and increase ground speed as load on the blades decreases. This allows the engine, working with the transmission, to sense the proper ground speed while maintaining high blade tip speed necessary for good quality-of-cut. Therefore, allow traction pedal to move upward as engine rpm decrease, and depress pedal slowly as rpm increase. By comparison, when driving from one work area to another — with no load and cutting unit raised — have throttle in FAST position and depress traction pedal slowly but fully to attain maximum ground speed.

Another characteristic to consider is the operation of the brakes. The brakes can be used to assist in turning the machine; however, use them carefully, especially on soft or wet grass because the turf may be torn accidentally. The brakes can also be used for control of the cutting unit. The brakes can be used to great advantage to control the direction of the cutting unit when trimming along fences or similar objects. Another benefit of the brakes is to maintain traction. For example: in some slope conditions, the uphill wheel slips and loses traction. If this situation occurs, depress uphill brake pedal gradually and intermittently until the uphill wheel stops slipping; thus, increasing traction on the downhill wheel. If independent braking is not desired, engage the lever on right brake pedal with left pedal. This provides simultaneous braking at both wheels.

Before stopping the engine, disengage all controls and move throttle to SLOW. Moving throttle to

OPERATING INSTRUCTIONS

SLOW reduces high engine rpm, noise, vibration and the possibility of backfiring by the engine. Turn key to OFF to stop engine.

PUSHING OR TOWING TRACTION UNIT

In an emergency, the traction unit can be pushed or towed for a very short distance. However, Toro does not recommend this as standard procedure.

IMPORTANT: Do not push or tow the traction unit faster than 2 to 3 mph (3.2 to 4.8 km/hr) because transmission may be damaged. If traction unit must be moved a considerable distance, transport it on a truck or trailer. Whenever traction unit is pushed or towed, by-pass valve must be open.

1. Unlatch and raise hood, remove knob from lift lever.
2. Remove capscrews, lockwashers and flat-washers securing seat support cover to frame.
3. Pivot seat forward and support it to prevent it from falling accidentally. Lift seat support cover off frame.
4. Depress and hold the pins located in the center

of the two (2) check valve assemblies in the top of the transmission (Fig. 15) while pushing or towing the machine.

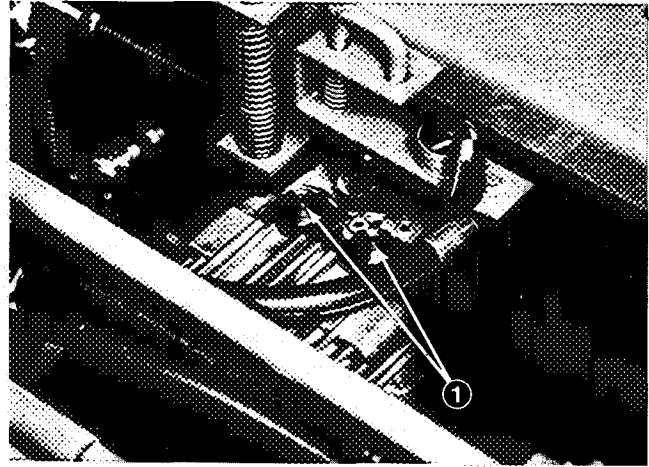

Figure 15

1. Check valve pins

5. Start engine momentarily after repairs are completed and make sure the pins are in the full disengaged (fully up) position.

IMPORTANT: Running the machine with by-pass valve open will cause the transmission to overheat.

LUBRICATION MAINTENANCE

GREASING BEARINGS AND BUSHINGS

The traction unit grease fittings must be lubricated regularly with No. 2 General Purpose Lithium Base Grease. If machine is operated under normal conditions, lubricate all bearings and bushings after every 25 hours of operation. Bearings and bushings must be lubricated daily when operating conditions are extremely dusty and dirty. Dusty and dirty operating conditions could cause dirt to get into the bearings and bushings, resulting in accelerated wear.

Apply a liberal coating of grease to the check valve pins once each year (Fig. 15). Also grease the bearings in the Dana axle every 500 hours, or yearly, whichever comes first (not shown). The traction unit has bearings and bushings that must be lubricated, and these lubrication points are: PTO shaft (Fig. 16); lift arm pivot bushings (Fig. 17); intermediate steering arm pivot bearings (Fig. 18); brake pivot bushings (Fig. 18); PTO shaft engaging lever bearings (Fig. 19); rear wheel spindle bushings (Fig. 21); steering plate bushings (Fig. 20); axle pin bushing (Fig. 20); and PTO idler assembly bearings (Fig. 22). Also apply grease to both brake cables at the drive wheel and brake pedal ends (Fig. 18).

1. Wipe grease fitting clean so foreign matter cannot be forced into the bearing or bushing.
2. Pump grease into the bearing or bushing.
3. Wipe up excess grease.

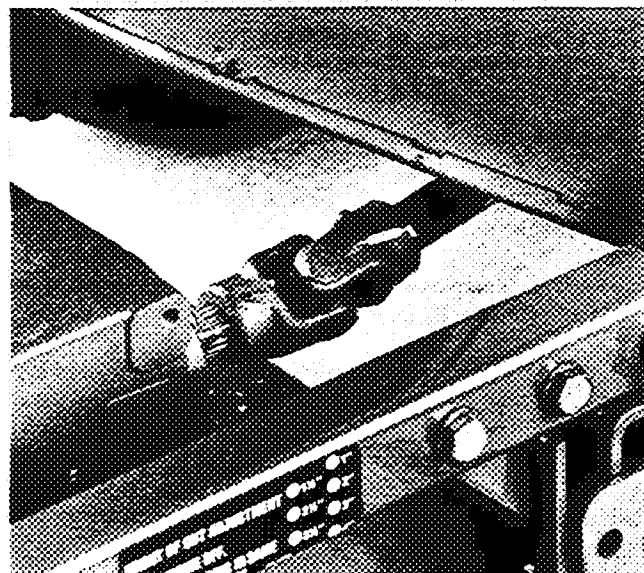

Figure 16

LUBRICATION MAINTENANCE

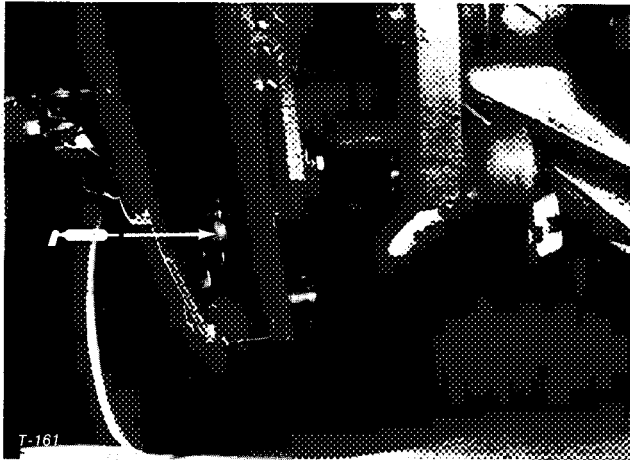

Figure 17



Figure 20

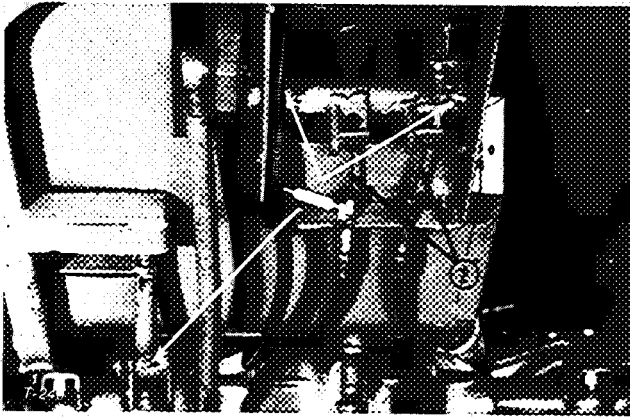

Figure 18

1. Apply grease to cable ends

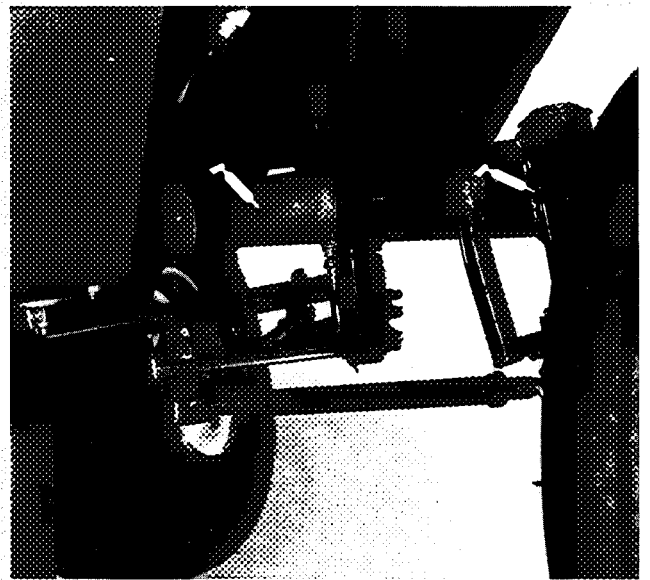

Figure 21



Figure 19

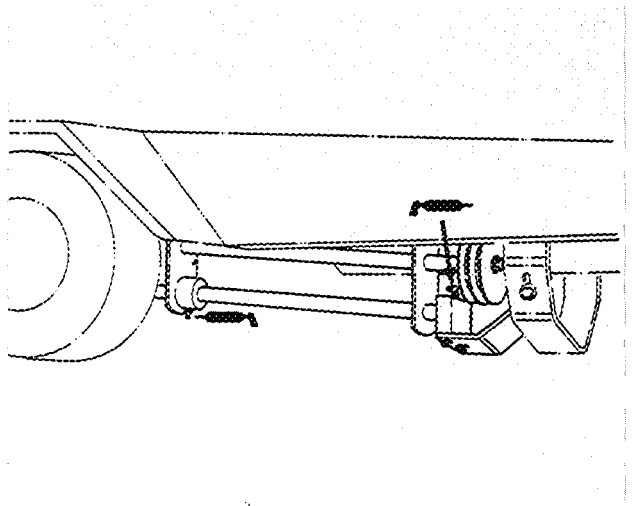

Figure 22

BRAKE MAINTENANCE

ADJUSTING SERVICE BRAKES

Adjust the service brakes when there is more than one inch (25 mm) of "free travel" of the brake pedals, or when the brakes do not work effectively. Free travel is the distance the brake pedal moves before braking resistance is felt.

The brakes should be checked for adjustment after the first 25 hours operation and should only need adjusting after considerable use thereafter. These periodic adjustments can be performed where the brake cables connect to the bottom of the brake pedals. When the cable is no longer adjustable, the star nut on inside of the brake drum must be adjusted to move the brake shoes outward. However, the brake cables must be adjusted again to compensate for this adjustment.

1. Disengage lock arm from left brake pedal so both pedals work independently of each other.

2. To reduce free travel of brake pedals — tighten the brakes — loosen front nut on threaded end of brake cable (Fig. 23). Then tighten rear nut to move cable backward until brake pedals have 1/2 to 1 inch (13 mm to 25 mm) of free travel. Tighten front nut after brakes are adjusted correctly.

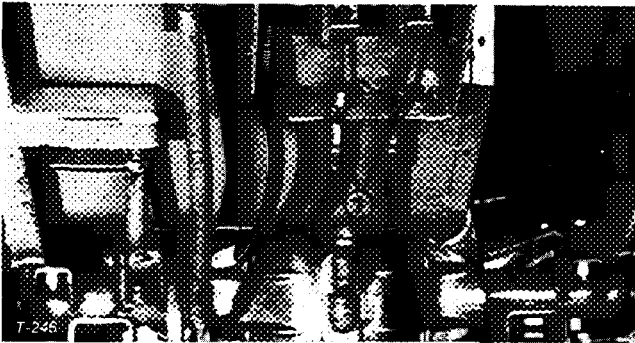

Figure 23
1. Jam nuts

3. When adjustment of brake cables cannot get free travel within 1/2 to 1 inch (13 mm to 25 mm), the star-nut inside the brake drum must be adjusted. However, before adjusting the star-nut, loosen brake cable nuts to prevent unnecessary strain on the cables.

4. Loosen five wheel nuts holding wheel and tire assembly on wheel studs.

5. Jack up machine until front wheel is off the shop floor. Use jack stands or block the machine to prevent it from falling accidentally.

6. Remove wheel nuts and slide wheel and tire assembly off studs. Rotate brake drum until adjusting slot is at top and centered over star-nut that adjusts brake shoes (Fig. 24).



Figure 24

1. Brake adjusting slot

7. Using a brake adjusting tool or screwdriver rotate star-nut (Fig. 25) until brake drum (Fig. 24) locks because of outward pressure of brake shoes (Fig. 25).

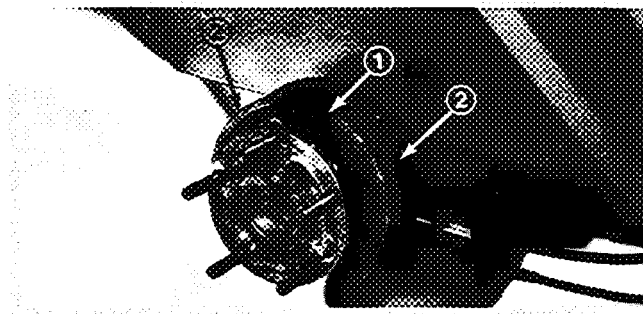

Figure 25

1. Star nut
2. Brake shoe

8. Loosen star-nut about 12 to 15 notches or until brake drum rotates freely.

9. Install wheel and tire assembly on studs with five wheel nuts. Tighten nuts to 60-80 ft-lb (81-109N·m).

10. Remove jack stands or blocking and lower machine to the shop floor.

11. Adjust the brake cables; use step 2.

AIR CLEANER MAINTENANCE

GENERAL MAINTENANCE PRACTICES

Inspect air cleaner and hose periodically to maintain maximum engine protection and to ensure maximum service life.

1. Assure hose between air cleaner and carburetor is clamped securely in place. Replace the hose if it is cracked or punctured.
2. Check air cleaner body for dents and other damage which could possibly cause an air leak. Replace a damaged air cleaner body.
3. Insure dust cap is sealing around bottom of air cleaner body.
4. Mounting screws and nuts holding air cleaner in place must be tight.
5. Inlet cap must be free of obstructions.

SERVICING DUST CUP AND BAFFLE

Inspect the dust cup and rubber baffle once a week or every 50 hours operation; however, daily or more frequent inspection is required when operating conditions are extremely dusty and dirty. Never allow dust to build up closer than one inch (25 mm) from the rubber baffle.

Note: If conditions are extremely dusty and dirty, begin by checking dust cup and baffle after each day's operation to establish approximately how long an interval passes before dust cup should be emptied. Base further maintenance requirements on this figure. These conditions may be particularly prevalent if the rear discharge cutting unit is attached.

1. Loosen thumb screw until dust cup and baffle can be removed (Fig. 26). Separate dust cup and baffle (Fig. 26).

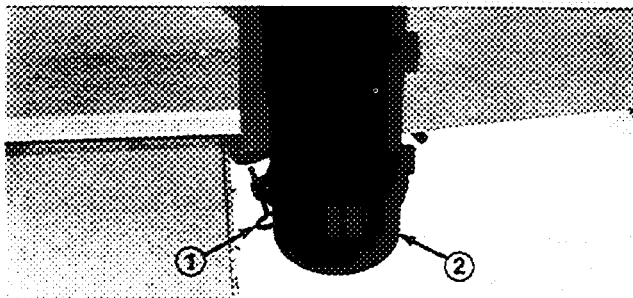

Figure 26

1. Thumb screw
2. Dust cup

2. Dump dust out of the dust cup. After cleaning cup and baffle, assemble and reinstall both parts.

SERVICING AIR CLEANER FILTER

Service the air cleaner filter every 250 hours or more frequently in extreme dusty or dirty conditions by washing or using compressed air. Replace the element after every six cleanings (1500 hours) or annually, whichever comes first.

1. Remove and service dust cup; refer to Servicing Dust Cup and Baffle, page 19.
2. Remove wing nut w/gasket and slide filter element out of air cleaner body (Fig. 27)

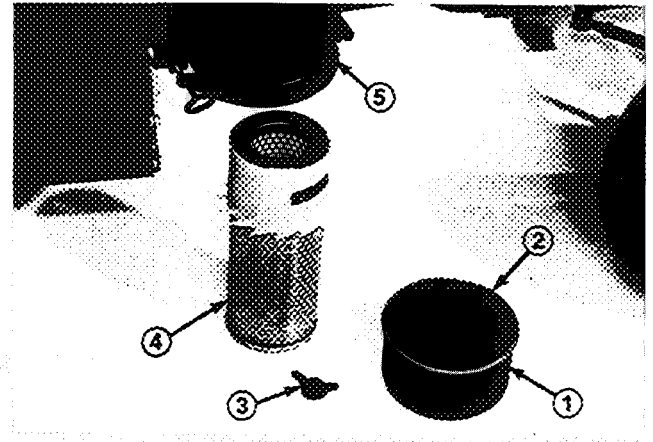

Figure 27

1. Dust cup
2. Baffle
3. Wing nut with gasket
4. Filter element
5. Air cleaner body

3. Clean the element by washing it in a solution of filter cleaner (Part No. 27-7220, available from Toro) and water, or blow dirt out of filter by using compressed air.

Note: Compressed air is recommended when element must be used immediately after servicing because a washed element must be dried before it is used. By comparison, washing the element cleans better than blowing dirt out with compressed air. Remember though, filter must be washed when exhaust soot is lodged in the filter pores.

Washing Method

IMPORTANT: Do not remove plastic fin assembly because washing removes dust from beneath fins.

- A. Prepare a solution of filter cleaner and water and soak filter element about 15 minutes. Refer to directions on filter cleaner carton for complete information.
- B. After soaking filter for 15 minutes, rinse it with clear water. Maximum water pressure must not exceed 40 psi (276 kPa) to prevent damage to the filter element.

AIR CLEANER MAINTENANCE

- C. Dry filter element using warm, flowing air (160°F (71°C) max). or allow element to air-dry. Do not use compressed air or a light bulb to dry the filter element because damage could result.

Compressed Air Method

IMPORTANT: Do not remove plastic fin assembly because back-blowing with compressed air removes dust from beneath fins.

- A. Blow compressed air from inside to the outside of dry filter element. Do not exceed 100 psi (689 kPa) to prevent damage to the element.
- B. Keep air hose nozzle at least one inch (25 mm) from pleated paper, and move nozzle up and down while rotating the filter element. Inspect element when dust and dirt are removed; refer to Inspecting Filter Element, page 20.

4. Wipe inside of air cleaner body with a damp cloth to remove excess dust. Slide filter into air cleaner body and secure it in place with wing nut and gasket.

5. Reinstall dust cup and baffle. Move thumb screw behind air cleaner body and tighten it securely.

INSPECTING FILTER ELEMENT

1. Place bright light inside filter.
2. Rotate filter slowly while checking for cleanliness, ruptures, holes and tears. Replace faulty filter element.
3. Check fin assembly, gasket and screen for damage. Replace filter if damage is evident.

ENGINE MAINTENANCE

CHANGING CRANKCASE OIL AND FILTER

Check oil level after each days operation or each time machine is used. Change oil and oil filter after every 50 hours of operation. However, change oil more frequently when engine is operated in dusty or sandy conditions. If possible, run engine just before changing oil because warm oil flows better and carries more contaminants than cold oil.

1. Position machine on a level surface.
2. Disengage hood latch and open the hood. Set drain pan under the housing and in line with drain plug (Fig. 28).

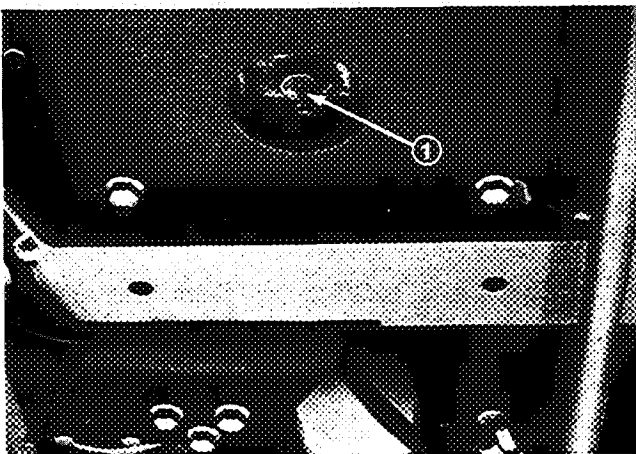

Figure 28
1. Oil drain plug

3. Clean area around drain plug.
4. Remove oil drain plug and allow oil to flow into drain pan. Remove and replace oil filter (Fig. 29); refer to parts catalog for part number.

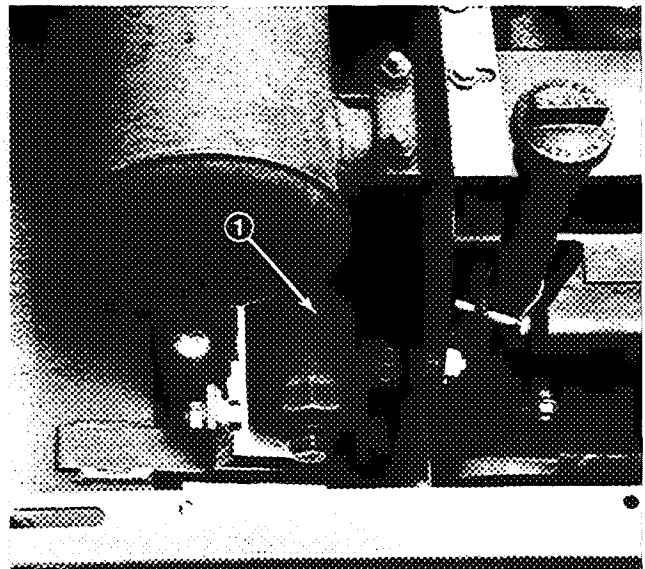

Figure 29
1. Engine oil filter

5. After oil is drained, reinstall drain plug and filter and wipe up any oil that spilled.
6. Fill crankcase with oil; refer to Check Crankcase Oil, page 11.

ENGINE MAINTENANCE

CLEANING CYLINDER HEAD FINS

To avoid overheating and possible engine damage, clean cooling fins on cylinder head after every 50 hours of operation if necessary.

1. Open the hood. Pull high tension wires off spark plugs.

2. Remove self-tapping screws at top and bottom of right hand engine housing and locknut and capscrew next to oil fill and dipstick assembly (Fig. 30).

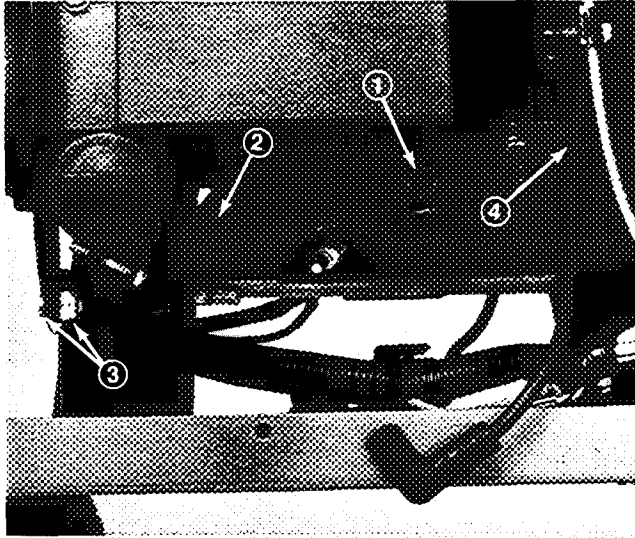

Figure 30

1. Self-tapping screw
2. Right engine housing
3. Locknut and capscrew
4. Spark plug lead retainer

3. Remove spark plug lead from retainer and pry housing away from engine (Fig. 31). Clean dirt, grass and chaff from cylinder and cylinder head fins.

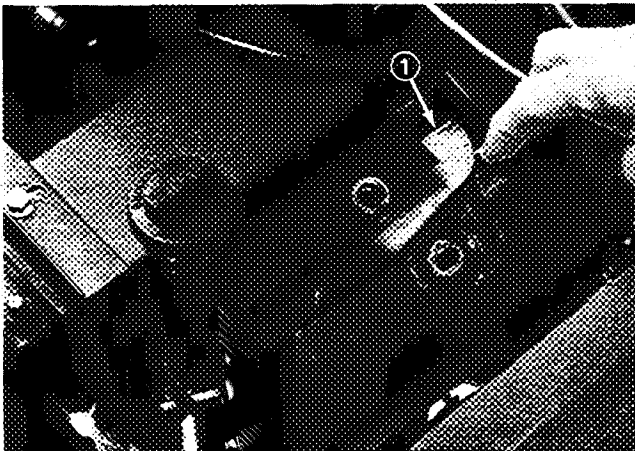

Figure 31

1. Cylinder fins

4. Reinstall housing, secure fasteners and install spark plug lead in retainer.

5. Remove self-tapping screw securing voltage regulator to left engine housing and remove regulator (Fig. 32).

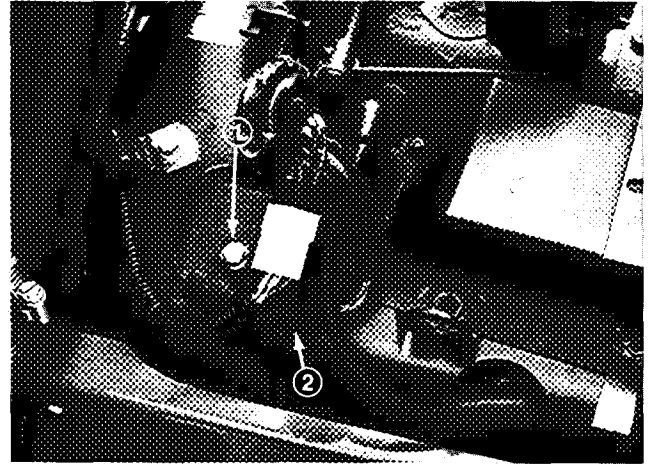

Figure 32

1. Self-tapping screw
2. Voltage regulator

6. Through opening, clean dirt, grass and chaff from outside of cylinder and cylinder head fins (Fig. 33).

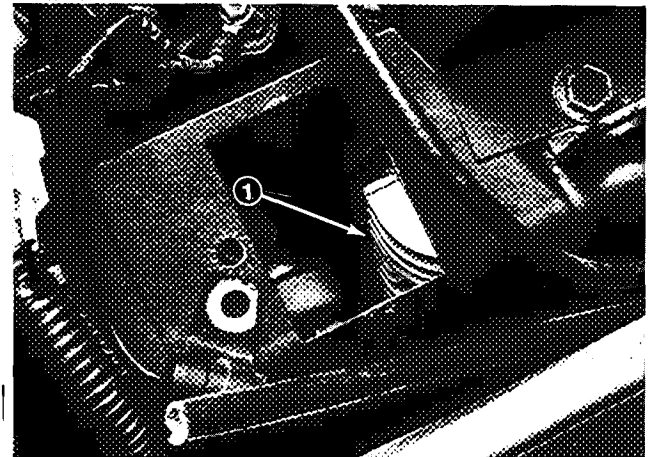

Figure 33

1. Cylinder fins

7. Reinstall voltage regulator with self-tapping screw.

CLEANING COMBUSTION CHAMBER

Clean the combustion chamber after every 1000 hours of operation if unleaded gasoline is used.

A gradual buildup of carbon deposits will form in the combustion chamber causing the engine to lose power and prevent the valves from seating properly. However, periodic cleaning will prolong valve life and make sure the engine is reliable. Refer to Toro Service Manual for Onan Engine or contact an Authorized TORO Service Distributor.

FUEL SYSTEM MAINTENANCE

ADJUSTING CARBURETOR

The carburetor has been adjusted at the factory and should not have to be reset. Should the carburetor require adjustment, use the following procedure:

IMPORTANT: Check fuel filter and air cleaner, and make sure the choke is operating correctly before the carburetor is adjusted.

1. Idle Mixture Screw (Fig. 34) — Close idle mixture screw by gently rotating it clockwise.

IMPORTANT: Do not close the idle mixture screw too tight because the screw and seat in carburetor will likely be damaged.

2. Rotate — open — the idle mixture screw 1-1/8 turns counterclockwise.

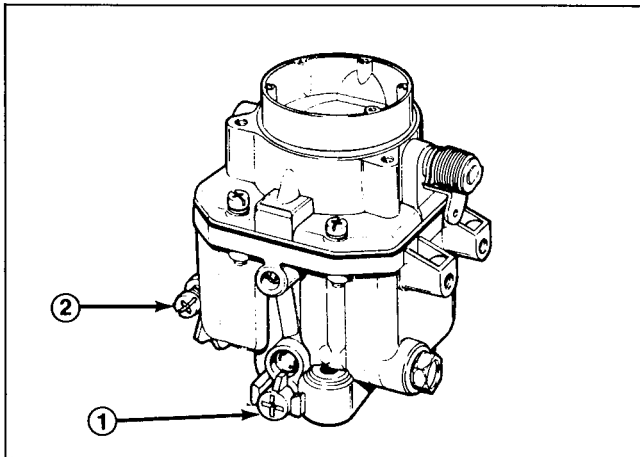

Figure 34

1. Idle mixture screw
2. Throttle stop screw



WARNING

Engine must be running so final adjustment of the carburetor can be performed. To guard against possible personal injury, keep hands, feet, face and other parts of the body away from the muffler, other hot parts of the engine, and other moving or rotating parts of the engine. Assure PTO lever is in **DISENGAGE** position and cutting unit is on the shop floor. Also engage parking brake.

3. Start engine and let it warm up for approximately ten minutes. When engine is at normal operating temperature, proceed with adjustments.

4. Move the throttle control to the slow position. Back out the low speed screw on the governor so that the throttle stop screw on the carburetor

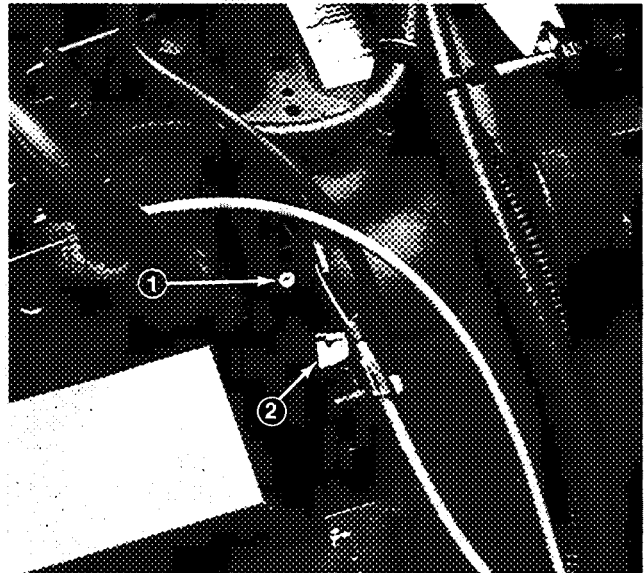

Figure 35

1. Low speed screw
2. High idle tab

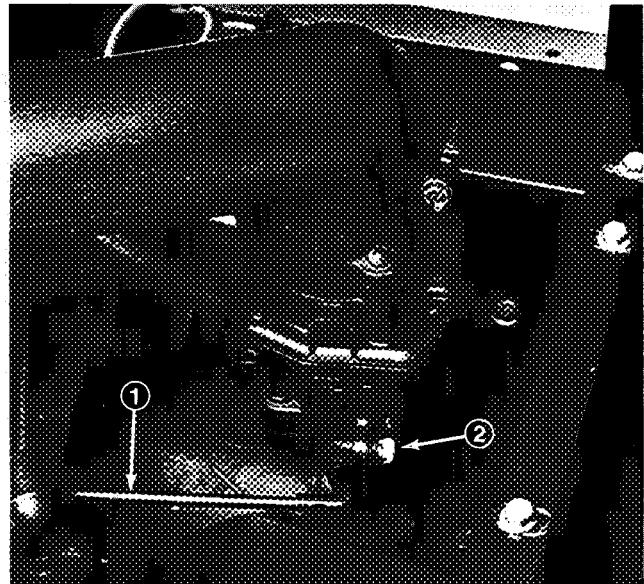

Figure 36

1. Idle control rod
2. Idle stop screw

5. Determine the best idle mixture setting by first turning the idle adjustment screw in until the engine speed drops, then outward until engine speed drops again. Over a narrow range between these two settings engine speed remains at its highest. Set the idle adjustment screw about 1/8 turn outward (rich) from the midpoint of this range.

FUEL SYSTEM MAINTENANCE

6. Adjust low and high idles. Refer to Adjusting Low Speed Idle, page 23 and Adjusting High Speed Idle, page 23.

7. Check carburetor adjustment by moving throttle control quickly from SLOW to FAST. Engine speed should increase without hesitation. If engine tends to stall or die out, turn the main adjustment screw out 1/8 turn until engine accelerates smoothly, but do not turn it out more than 1/2 turn beyond the original setting.

ADJUSTING LOW SPEED IDLE

1. Open the hood, start the engine, and move the throttle control to the SLOW position.
2. Check engine rpm. Correct setting should be 1500 rpm.
3. If adjustment is necessary, adjust low speed screw located on governor control arm to 1500 rpm.
4. Holding idle control rod against throttle stop screw on carburetor, adjust throttle stop screw 100 rpm lower than setting on low speed screw (1400 rpm).
5. Stop the engine and close the hood.

ADJUSTING HIGH SPEED IDLE

1. Open the hood, start the engine, and move the throttle control to the FAST position.
2. Check engine rpm. The correct setting should be 3200 rpm.
3. If adjustment is necessary, bend high idle tab to correct setting.

4. Stop the engine and close the hood.

REPLACING FUEL FILTER

Replace the fuel filter after every 250 hours or yearly, whichever comes first.

1. Clamp both fuel lines that connect to the fuel filter (Fig. 37) so gasoline cannot drain when lines are removed.

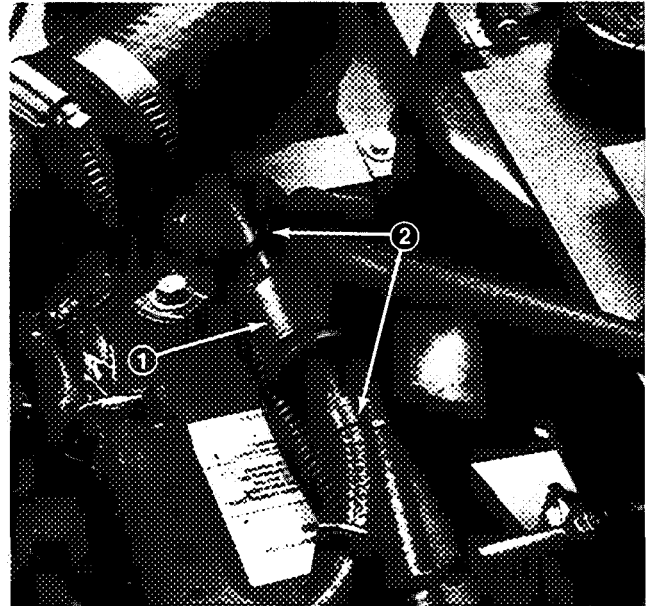

Figure 37

1. Fuel filter
2. Hose clamps

2. Loosen the hose clamps (Fig. 37) at both ends of the filter, pull fuel lines off and discard filter.
3. Be sure arrow on side of filter points toward the carburetor. Slide hose clamps onto ends of fuel lines and push fuel lines onto fuel filter.

ELECTRICAL MAINTENANCE

CHECKING AND REPLACING SPARK PLUGS

Since air gap between center and side electrodes increases gradually during normal engine operation, check condition of electrode at 500 hour intervals. The correct spark plugs to use in the engine are Champion RS14YC or equivalent. Set air gap at 0.025 in. (0.64 mm).

1. Clean area around spark plugs so dirt does not fall into cylinder when plugs are removed.
2. Pull high tension wires off spark plugs and remove plugs from cylinder head (Fig. 38).

3. Check condition of center and side electrodes to determine operating temperature of engine.

- A. Light brown insulator tip indicates correct spark plug and heat range.
- B. Black or oily insulator tip indicates an excessively rich fuel mixture, possibly caused by a dirty air cleaner element or a carburetor that is set too rich.
- C. Light gray or blistered-white insulator indicates overheating caused by a lean carburetor setting or incorrect spark plug (heat range too high).

ELECTRICAL MAINTENANCE

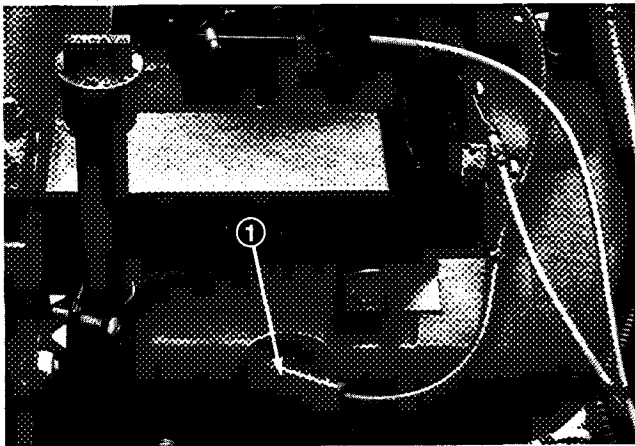

Figure 38

1. High tension wire (right side)

IMPORTANT: A cracked, fouled or dirty spark plug must be replaced. Do not sandblast, scrape or clean electrodes by using a wire brush because grit may release from the plug and enter combustion chamber resulting in engine damage.

4. After setting air gap at 0.025 in. (0.64 mm), install spark plugs in cylinder head. Tighten the plug to 22 ft-lb (30 N·m). Push high tension wires onto spark plugs.

SOLID STATE IGNITION

Ignition timing is set at the factory and is not adjustable. The solid state components are not adjustable and require no routine maintenance.

SERVICING BATTERY

IMPORTANT: Before welding on the machine, disconnect ground cable from the battery to prevent damage to the electrical system.

Note: Check battery condition weekly or after every 50 hours of operation. Keep terminals and entire battery case clean because a dirty battery will discharge slowly. To clean the battery, wash the entire case with solution of baking soda and water. Rinse with clear water. Coat the battery posts and cable connectors with Grafo 112X (Skin-over) grease, Toro Part No. 505-47 or petroleum jelly to prevent corrosion.

WIRING HARNESS SERVICE

Prevent corrosion of wiring terminals by applying Grafo 112X (Skin-over) grease, Toro Part No. 505-47, to the inside of all harness connectors whenever the harness is replaced.

Always disconnect battery cables, ground cable (-) first, to prevent possible wiring damage from short-outs whenever working with the electrical system.

ADJUSTING PTO LEVER SWITCH

1. Visually check PTO lever to be sure it deflects switch arm when lever is in the disengaged position (Fig. 39). Back surface of PTO lever must be within 1/4 to 3/8 in. (6 mm to 10 mm) from end of the slot (Fig. 39). If PTO lever does not deflect switch arm, proceed to step 2.

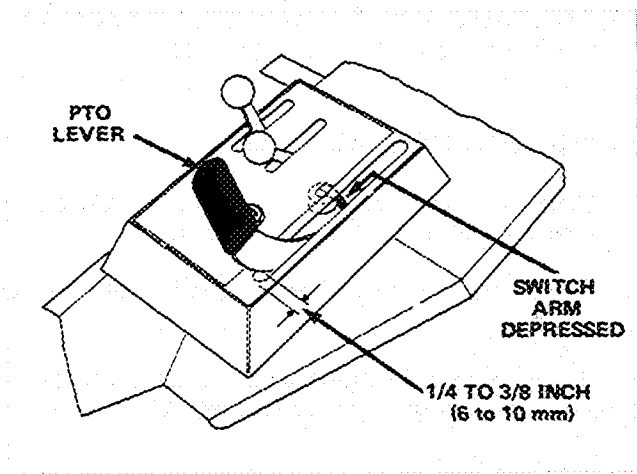

Figure 39

2. Pull high tension wire off spark plugs. To adjust the PTO lever, remove the seat cover. Loosen jam nut from PTO engaging yoke (Fig. 40). Loosen adjusting screw until PTO lever is within 1/4 - 3/8 in. (6-10 mm) from end of the slot, when lever is in the disengage position (Fig. 39). This will deflect the switch arm. Tighten jam nut against yoke to lock the adjustment in place (Fig. 40). Move PTO lever to disengage position and rotate locknut at top of spring until the dimension of spring, between the top and bottom flatwasher, is 3-9/16 in. (9.0 cm) (Fig. 40). Repeat step 1.

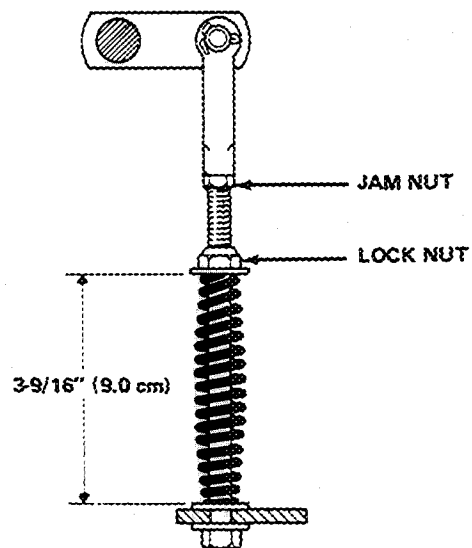
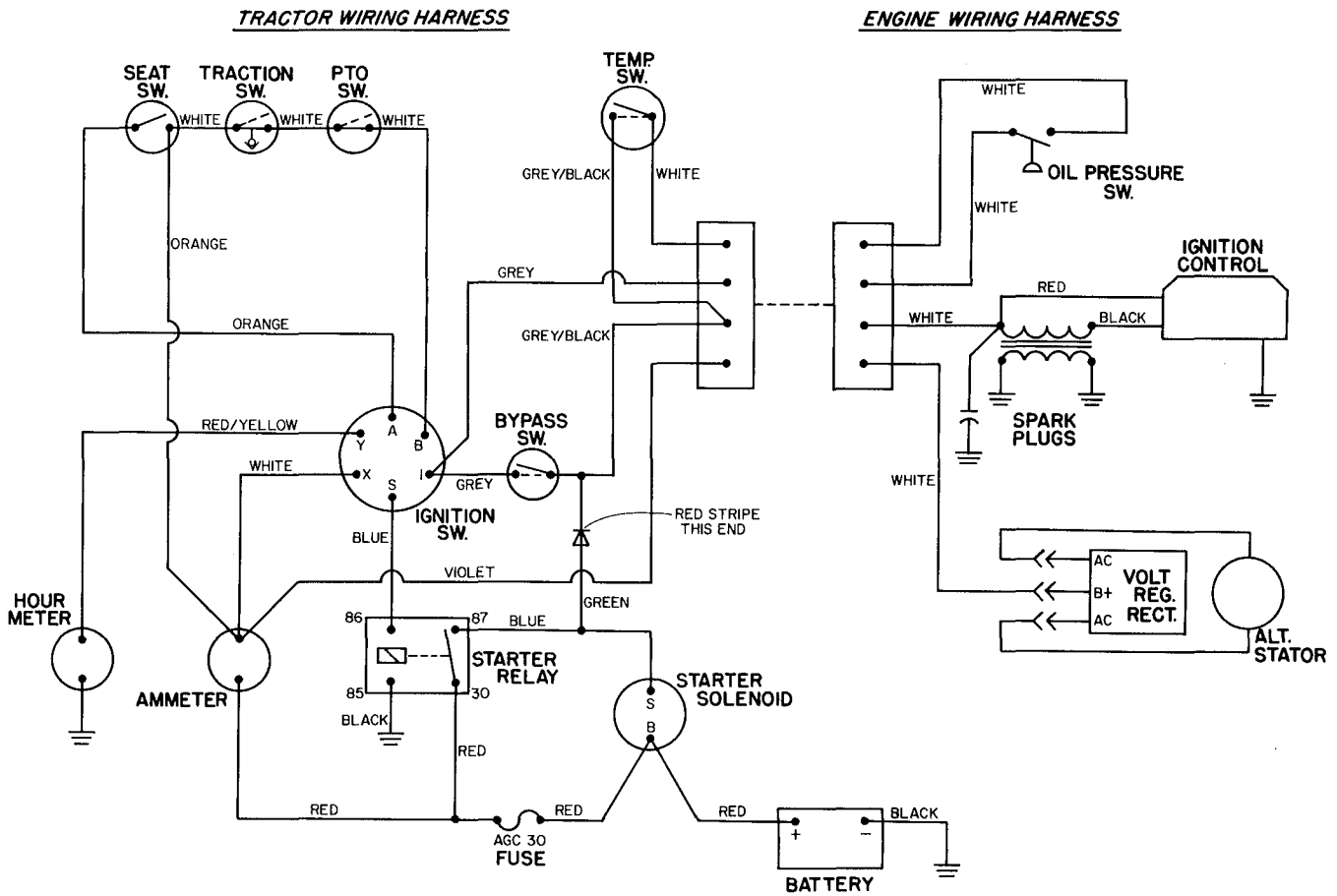

Figure 40

WIRING SCHEMATIC



HYDRAULIC SYSTEM MAINTENANCE

ADJUSTING TRANSMISSION FOR NEUTRAL

The machine must not creep when traction pedal is released. If it does creep, an adjustment is required.

1. Park machine on a level surface and shut engine off. Depress only the left brake pedal and engage the parking brake.

2. Jack up right front side of machine until tire is off shop floor. Support machine with jack stands to prevent it from falling accidentally.

3. Visually inspect traction linkage for possible binding condition, correct, if necessary, and check machine operation. If condition still exists, repeat steps 1 and 2 and proceed to step 4.

4. Loosen two locknuts securing pump plate so plate is free to move (Fig. 41).

5. Start engine and rotate pump plate (Fig. 41) in either direction until wheel ceases rotation.

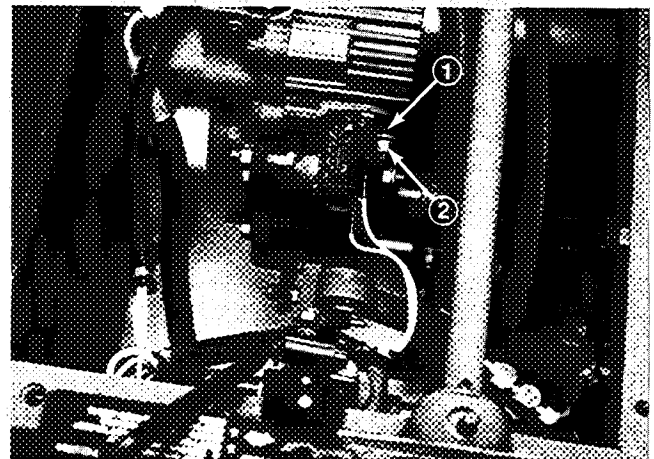

Figure 41

1. Pump plate 2. Locknut (2)

6. Stop engine and tighten locknuts to secure pump plate (Fig. 41).

7. Start engine and check adjustment. Repeat adjustment, if necessary.

HYDRAULIC SYSTEM MAINTENANCE

8. Stop the engine and release left parking brake. Remove jack stands and lower machine to the shop floor. Test drive the machine to be sure it does not creep.

CHANGING HYDRAULIC OIL AND FILTER

Initially, replace the hydraulic system oil and filter after the first full days' operation — NOT TO EXCEED 10 HOURS. Replace the oil and filter every 250 hours operation, or yearly, whichever comes first thereafter.

The hydraulic system is designed to operate on any high quality detergent oil having the American Petroleum Institute — API — "service classification" SF/CC or CD. Oil viscosity — weight — must be selected according to anticipated ambient temperature for the season in which product will be used.

Temperature/viscosity recommendations are:

Expected Ambient Temperature	Recommended Viscosity and Type
(Extreme) over 90°F	SAE 30, Type SF/CC or CD engine oil.
(Normal) 40-100° F	SAE 10W-30 or 10W-40, Type SF/CC or CD engine oil.
(Cool — Spring/Fall) 30-50° F	SAE 5W-30, Type SF/CC or CD engine oil.
(Winter) Below 30° F	Type "F" or "FA" ATF Automatic Transmission Fluid.

Note: Do not mix engine oil and automatic transmission fluid or hydraulic system component damage may result. When changing fluids, also change transmission filter. **DO NOT USE DEXTRON II ATF.**

The axle housing acts as the reservoir for the system. The transmission and axle housing are shipped from the factory with approximately 5 quarts (4.7 l) of SAE 10W-30 engine oil. However, check level of transmission oil before engine is first started and daily thereafter.

1. Lower cutting unit to shop floor, set parking brake, and turn engine OFF. Block the two rear wheels.

2. Jack up both sides of the front axle and support it with jackstands.

3. Clean the area around the hydraulic oil filter and remove the filter (Fig. 42).



Figure 42

1. Filter

4. Remove the tube that connects the axle housing to the transmission and allow the oil to flow into a drain pan.

5. Install new hydraulic oil filter and connect the tube between axle housing and transmission. Fill axle (reservoir) to proper level — approx. 5 qt (4.7 l); refer to Check Hydraulic System Fluid. Remove the jack stands.

6. Start engine, and lower cutting unit or implement lift and check for oil leaks. Allow engine to run for about five minutes. Then shut engine off.

7. After two minutes, check level of transmission fluid; refer to Check Hydraulic System Fluid.

PRODUCT IDENTIFICATION

The traction unit has two identification numbers: a model number and a serial number that are stamped into a plate. The identification plate is located near the right end of the seat hinge (Fig. 43). In any correspondence concerning the traction unit, supply the model and serial numbers to ensure correct information and replacement parts are obtained.



Figure 43

1. Model and serial number

PRODUCT IDENTIFICATION

To order replacement parts from an Authorized TORO Proline Dealer, supply the following information:

1. Model and serial numbers of the traction unit.

2. Part number, description and quantity of parts desired.

Note: Do not order by reference number if a parts catalog is being used; use the part number.

PREPARATION FOR SEASONAL STORAGE

Traction Unit

1. Thoroughly clean the traction unit, cutting unit and the engine, paying special attention to these areas:
 - underneath the cutting unit
 - under the cutting unit belt covers
 - counterbalance springs
 - P.T.O. Shaft Assembly
 - all grease fittings and pivot points
2. Check the tire pressure. Inflate all traction unit tires to 10 to 15 psi (69 to 103 kPa).
3. Remove, sharpen and balance the cutting unit's blades. Reinstall the blades and torque the blade fasteners to 75-100 ft-lb (102-136 N·m).
4. Check all fasteners for looseness; tighten as necessary.
5. Grease or oil all grease fittings, pivot points, and transmission by-pass valve pins. Wipe off any excess lubricant.
6. Ensure the P.T.O. lever remains in the disengaged position so the P.T.O. belt does not take a "set."
7. Lightly sand and use touch up paint on painted areas that are scratched, chipped or rusted. Repair any dents in the metal body.
8. Service the battery and cables as follows:
 - a. Remove the battery terminals from the battery posts.
 - b. Clean the battery, terminals and posts with a wire brush and baking soda solution.
 - c. Coat the cable terminals and battery posts with Grafo 112X skin-over grease (Toro Part Number 505-47), or petroleum jelly to prevent corrosion.

- d. Slowly recharge the battery every 60 days for 24 hours to prevent lead sulfation of the battery.

Engine

1. Drain the engine oil from the oil pan and replace the drain plug.
2. Remove and discard the oil filter. Install a new filter.
3. Refill the engine with 1.8 qt (1.7 l) of recommended motor oil. Refer to Changing Crankcase Oil, page 20.
4. Start the engine and run at idle speed for two minutes. **DO NOT RUN LONGER THAN TWO MINUTES.**
5. Stop the engine; remove spark plugs.
6. Pour one ounce (28cc) of clean engine oil in spark plug holes.
7. With the spark plugs removed, crank the engine with the starter for at least 12 revolutions to distribute the oil in the cylinders.
8. Reinstall the spark plugs.
9. Drain the gasoline from the fuel tank and fuel lines. Reinstall all lines and secure all connections.
10. Clean governor linkage and protect by wrapping with a clean cloth.
11. Thoroughly clean and service the air cleaner assembly.
12. Seal the air cleaner inlet and the exhaust outlet with weatherproof masking tape.
13. Check the oil filler cap and gas cap to ensure they are securely in place.

SERVICE INTERVAL CHART

Date												
Hour Meter Reading												
Service Interval		↓	Daily	5	25	50	75	100	125	150	175	200
Clean Blower Screen	Daily											
Oil Level Check, Engine	Daily											
Oil Level Check, Hyd.	Daily											
Safety Interlock Check	Daily											
Hydraulic Oil and Oil Filter Changed (Initial)	Within 10											
Oil Change, Initial	25											
Air Cleaner Cleaned	25											
Lubrication, Grease/Oil	25											
Tire Pressure Checked (12 psi)	25											
Hoses, Lines, Fittings & Pump Checked for Leaks	25											
Oil Change, Routine	50											
Engine Oil Filter	50											
Check Battery	50											
PTO Belt Tension Check	50											
Air Cleaner (Dust Cap & Baffle)	50											
Cooling Fins Cleaned	50											
Brakes Checked	100											
Hydraulic Oil Filter, Changed	250											
Fuel System Checked	250											
Fuel Filter Change	250											
Engine rpm Checked	250											
Service Air Cleaner (Filter)	250											
Combustion Chamber Clean (Leaded Fuel)	250											
Check Steering	250											
Check Rear Wheel Toe-in	250											
Spark Plug, Check	500											
Hydraulic Oil, Changed	500											
Transmission By-Pass Pins, Grease	500											
Valves Adjusted	1000											
Clean Breather Valve	1000											
Combustion Chamber Clean (Unleaded Fuel)	1000											
Replace all Interlock Switches (2 years)	1000											

SERVICE SPECIFICATIONS

Engine Oil: Refer to chart, page 11.

Spark Plug — RS14YC Gap is 0.025 of an inch (0.64 mm)

Hydraulic System Fluid — 5 quarts (4.73 l) of SAE 10W-30 engine oil

Hydraulic Oil Filter — Toro part no. 23-2300

SERVICE INTERVAL CHART

Date												
Hour Meter Reading												
Service Interval		↓	Daily	5	25	50	75	100	125	150	175	200
Clean Blower Screen	Daily											
Oil Level Check, Engine	Daily											
Oil Level Check, Hyd.	Daily											
Safety Interlock Check	Daily											
Hydraulic Oil and Oil Filter Changed (Initial)	Within 10											
Oil Change, Initial	25											
Air Cleaner Cleaned	25											
Lubrication, Grease/Oil	25											
Tire Pressure Checked (12 psi)	25											
Hoses, Lines, Fittings & Pump Checked for Leaks	25											
Oil Change, Routine	50											
Engine Oil Filter	50											
Check Battery	50											
PTO Belt Tension Check	50											
Air Cleaner (Dust Cap & Baffle)	50											
Cooling Fins Cleaned	50											
Brakes Checked	100											
Hydraulic Oil Filter, Changed	250											
Fuel System Checked	250											
Fuel Filter Change	250											
Engine rpm Checked	250											
Service Air Cleaner (Filter)	250											
Combustion Chamber Clean (Leaded Fuel)	250											
Check Steering	250											
Check Rear Wheel Toe-in	250											
Spark Plug, Check	500											
Hydraulic Oil, Changed	500											
Transmission By-Pass Pins, Grease	500											
Valves Adjusted	1000											
Clean Breather Valve	1000											
Combustion Chamber Clean (Unleaded Fuel)	1000											
Replace all Interlock Switches (2 years)	1000											

SERVICE SPECIFICATIONS

Engine Oil: Refer to chart, page 11.

Spark Plug — RS14YC Gap is 0.025 of an inch (0.64 mm)

Hydraulic System Fluid — 5 quarts (4.73 l) of SAE 10W-30 engine oil

Hydraulic Oil Filter — Toro part no. 23-2300

SERVICE INTERVAL CHART

Date												
Hour Meter Reading												
Service Interval		↓	Daily	5	25	50	75	100	125	150	175	200
Clean Blower Screen	Daily											
Oil Level Check, Engine	Daily											
Oil Level Check, Hyd.	Daily											
Safety Interlock Check	Daily											
Hydraulic Oil and Oil Filter Changed (Initial)	Within 10											
Oil Change, Initial	25											
Air Cleaner Cleaned	25											
Lubrication, Grease/Oil	25											
Tire Pressure Checked (12 psi)	25											
Hoses, Lines, Fittings & Pump Checked for Leaks	25											
Oil Change, Routine	50											
Engine Oil Filter	50											
Check Battery	50											
PTO Belt Tension Check	50											
Air Cleaner (Dust Cap & Baffle)	50											
Cooling Fins Cleaned	50											
Brakes Checked	100											
Hydraulic Oil Filter, Changed	250											
Fuel System Checked	250											
Fuel Filter Change	250											
Engine rpm Checked	250											
Service Air Cleaner (Filter)	250											
Combustion Chamber Clean (Leaded Fuel)	250											
Check Steering	250											
Check Rear Wheel Toe-in	250											
Spark Plug, Check	500											
Hydraulic Oil, Changed	500											
Transmission By-Pass Pins, Grease	500											
Valves Adjusted	1000											
Clean Breather Valve	1000											
Combustion Chamber Clean (Unleaded Fuel)	1000											
Replace all Interlock Switches (2 years)	1000											

SERVICE SPECIFICATIONS

Engine Oil: Refer to chart, page 11.

Spark Plug — RS14YC Gap is 0.025 of an inch (0.64 mm)

Hydraulic System Fluid — 5 quarts (4.73 l) of SAE 10W-30 engine oil

Hydraulic Oil Filter — Toro part no. 23-2300

SERVICE INTERVAL CHART

Date												
Hour Meter Reading												
Service Interval		↓	Daily	5	25	50	75	100	125	150	175	200
Clean Blower Screen	Daily											
Oil Level Check, Engine	Daily											
Oil Level Check, Hyd.	Daily											
Safety Interlock Check	Daily											
Hydraulic Oil and Oil Filter Changed (Initial)	Within 10											
Oil Change, Initial	25											
Air Cleaner Cleaned	25											
Lubrication, Grease/Oil	25											
Tire Pressure Checked (12 psi)	25											
Hoses, Lines, Fittings & Pump Checked for Leaks	25											
Oil Change, Routine	50											
Engine Oil Filter	50											
Check Battery	50											
PTO Belt Tension Check	50											
Air Cleaner (Dust Cap & Baffle)	50											
Cooling Fins Cleaned	50											
Brakes Checked	100											
Hydraulic Oil Filter, Changed	250											
Fuel System Checked	250											
Fuel Filter Change	250											
Engine rpm Checked	250											
Service Air Cleaner (Filter)	250											
Combustion Chamber Clean (Leaded Fuel)	250											
Check Steering	250											
Check Rear Wheel Toe-in	250											
Spark Plug, Check	500											
Hydraulic Oil, Changed	500											
Transmission By-Pass Pins, Grease	500											
Valves Adjusted	1000											
Clean Breather Valve	1000											
Combustion Chamber Clean (Unleaded Fuel)	1000											
Replace all Interlock Switches (2 years)	1000											

SERVICE SPECIFICATIONS

Engine Oil: Refer to chart, page 11.

Spark Plug — RS14YC Gap is 0.025 of an inch (0.64 mm)

Hydraulic System Fluid — 5 quarts (4.73 l) of SAE 10W-30 engine oil

Hydraulic Oil Filter — Toro part no. 23-2300



THE TORO TOTAL COVERAGE GUARANTEE

A One-Year Limited Warranty
(A Two-Year Full Warranty for Residential Use)

What Is Covered By This Express Warranty?

The Toro Company promises to repair any TORO product used for commercial, institutional, or rental purposes if defective in materials or workmanship for a period of one year from the date of purchase. The cost of parts and labor are included, but the customer pays the transportation cost. Transportation within a 15-mile radius of a TORO ProLine Service Dealer is covered under this warranty for Riding Products, Mid-size Mowers and Turf Maintenance Equipment.

What Products Are Covered By This Warranty?

The following products and their attachments are covered by this warranty:

- Z-Master Zero Radius Tractors
- ProLine Mid-size Mowers
- Groundsmaster Riding Mowers
- ProLine Hand-held Gas Products
- Backpack Blowers
- Commercial WPM
- Turf Maintenance Equipment
- Debris Management Equipment

How About Residential Use?

TORO products used for residential use are covered by a full two-year warranty.

How Do You Get Warranty Service?

Should you feel your TORO product contains a defect in materials or workmanship, contact the dealer who sold you the product or any TORO ProLine Service Dealer. The Yellow Pages of your telephone directory is a good reference source; look under TORO Commercial Service Dealers. The Service Dealer will either arrange service at his/her dealership or recommend another authorized Service Dealer who may be more convenient. You may need proof of purchase (copy of registration card, sales receipt, etc.) for warranty validation.

If for any reason you are dissatisfied with a Service Dealer's analysis of the defect in materials or workmanship or if you need a referral to a TORO ProLine Service Dealer, please feel free to contact us at the following address:

Toro Customer Service Department
8111 Lyndale Avenue South
Bloomington, MN 55420-1196
612-888-8801 or 800-348-2424

What Must You Do To Keep The Warranty In Effect?

You must maintain your TORO Product by following the maintenance procedures described in the operator's manual. Such routine maintenance, whether performed by a dealer or by you, is at your expense.

What Does This Warranty Not Cover? and

How Does Your State Law Relate To This Warranty?

There is no other express warranty except as described above. This express warranty does not cover:

- Cost of regular maintenance service or parts, such as filters, fuel, lubricants, tune-up parts, blade sharpening, brake and clutch adjustments.
- Any product or part which has been altered or misused or required replacement or repair due to normal wear, accidents, or lack of proper maintenance.
- Repairs necessary due to improper fuel, contaminants in the fuel system, or failure to properly prepare the fuel system prior to any period of non-use over three months.
- Pickup and delivery charges for distances beyond a 15-mile radius from a TORO ProLine Service Dealer.

All repairs covered by this warranty must be performed by a TORO Service Dealer using Toro approved replacement parts.

The Toro Company is not liable for indirect or consequential damages in connection with the use of the TORO Products covered by this warranty, including any cost or expense of providing substitute equipment or service during reasonable periods of malfunction or non-use pending completion of repairs under this warranty. Some states do not allow exclusions of incidental or consequential damages, so the above exclusion may not apply to you.

This warranty gives you specific legal rights, and you may also have other rights which vary from state to state.

COUNTRIES OTHER THAN THE UNITED STATES OR CANADA

Customers who have purchased TORO products exported from the United States or Canada should contact their TORO Distributor (Dealer) to obtain guarantee policies for your country, province, or state. If for any reason you are dissatisfied with your Distributor's service or have difficulty obtaining guarantee information, contact the TORO importer. If all other remedies fail, you may contact us at The Toro Company.