

COINSLIDE PRICE VEND CHANGE INSTRUCTIONS

The following procedure will guide the user through changing the coinslide vend amount for a factory equipped or ESD vertical 8 coinslide. The procedure will be similar for other coinslide manufacturers, consult the manufacturers installation instructions. If the coinslide(s) are installed, they must be removed prior to changing the vend price. If the coinslide(s) have not yet been installed, skip to step 6.

5. Unscrew the coinslide retaining bolt with a 5/16" socket by turning counter clock wise and remove the bolt.

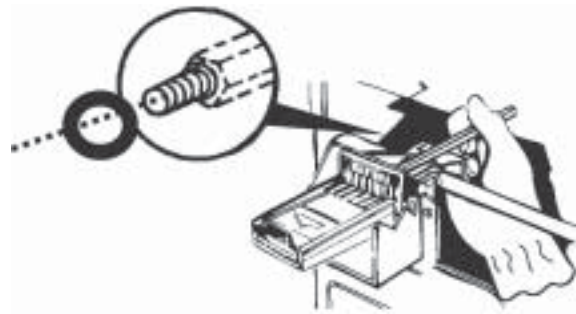

6. Push the coinslide up, and then pull it forward to remove from the metercase.

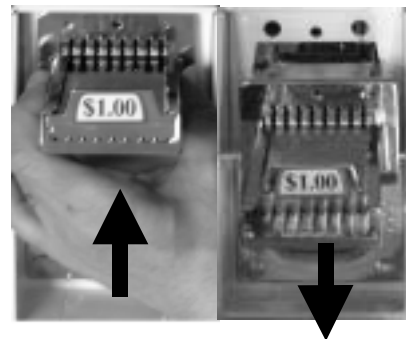

7. Set the coinslide and extension assembly on a level surface and remove the return spring(s) from the spring bracket.

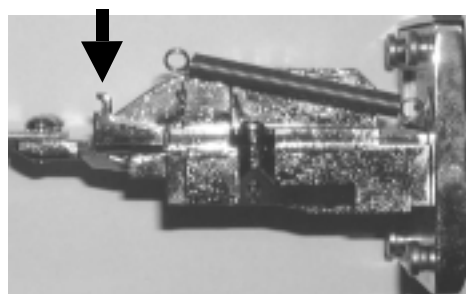

8. Place coins in the coinslide of the proper vend amount (factory preset on coin equipped models is \$1.00) and push the slide all the way in until the coins drop through the coinslide.

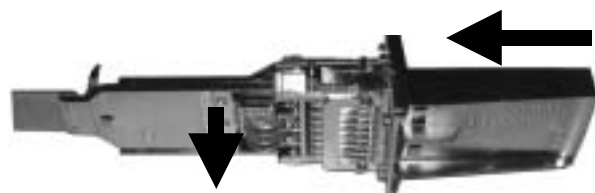

! WARNING



Electrical Shock Hazard

Disconnect power before servicing.

Replace all panels before operating.

Failure to do so can result in death or electrical shock.

1. Unplug unit or disconnect power.
2. Unlock the metercase access panel or collar control panel lock and remove the control panel from the collar assembly.
3. On single washer and dryer models, lift the metercase access panel up at the back and remove.
4. On mechanical stack dryer models open the console by lifting it up off the bottom mounting flange. On electronic stack dryers slide the control panel to the left, then carefully open the control panel by swinging the right side away from the collar.

9. With the slide still all the way inserted, remove the spring bracket screw and spring bracket.

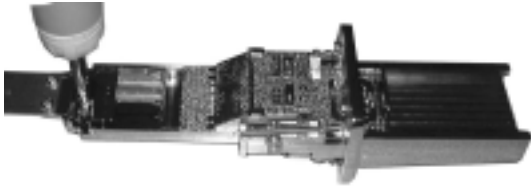

10. Remove the coin inserts (2 blanks, 2 functional) from the coinslide as shown.

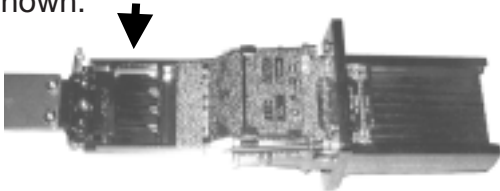

NOTE: The coinslide comes with enough inserts to increase or decrease the vend price by \$.50, if a higher or lower vend price is desired, more functional or blank inserts are necessary. Inserts may be ordered from Whirlpool Corporation only for models that come factory coinslide equipped. If the coinslide is other than Whirlpool factory equipped, additional inserts must be ordered from the coinslide manufacturer, page 13.

\$.25 US insert (Whirlpool Corp., Part No. 8316265)

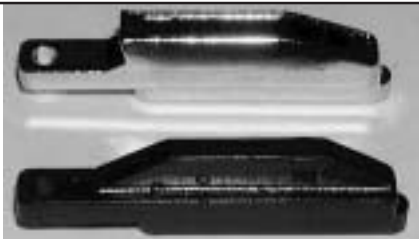

Insert blank (Whirlpool Corp., Part No. 8316264)

11. Turn the coinslide upside down and remove the three screws in the insert retaining plate.



12. To increase the vend price, remove blank inserts and install the metal functional inserts.

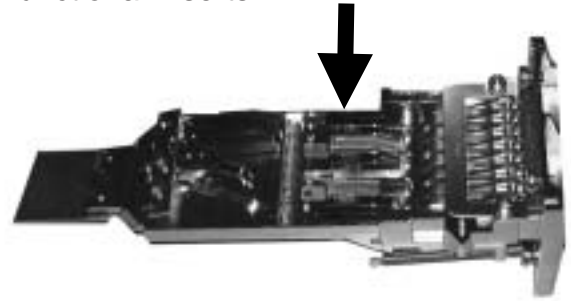

To decrease the vend price, remove functional inserts and replace with blank inserts.

13. Reinstall the three insert retaining plate screws. Turn the coinslide over and place unused inserts (up to 4) in the slide storage. Reinstall spring bracket and screw.

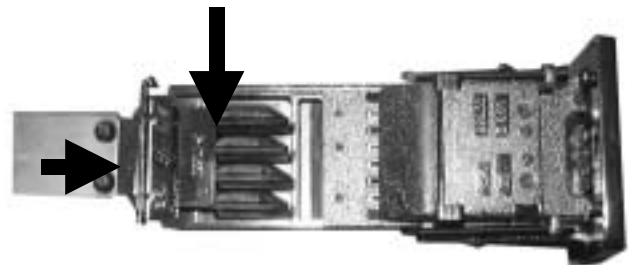

14. Release the slide and reinstall the coinslide return spring(s) onto the spring bracket.

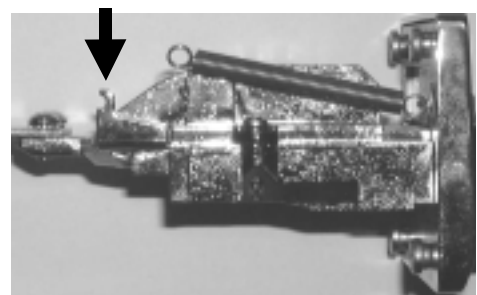

15. Insert coins in the amount of the new set vend price into the coinslide and push the slide in to eject the coins. If the coins do not eject, look for missing parts and go back to Step 7.

16. While holding the slide in, insert the coinslide into the metercase, making sure the extension clears the coin funnel. (Fig. 1)

17. Pull down slightly to lock the coinslide into place. (Fig. 2)

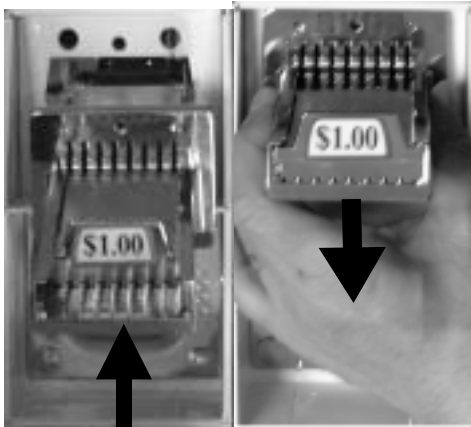
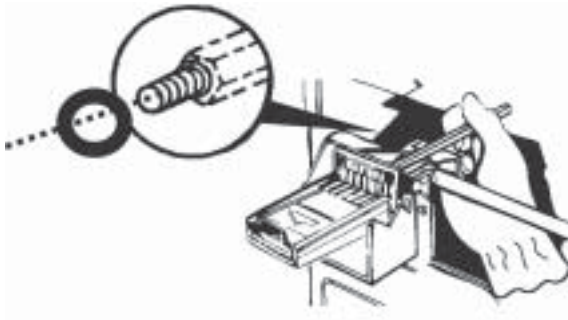

Fig. 1

Fig. 2

18. Insert the coinslide retaining bolt through the console access panel into the back of the coinslide and hand tighten the bolt to start the threads prior to using any tools to avoid stripping the coinslide or retaining bolt threads.



19. Affix the proper new vend price sticker to the front of the coinslide.

! WARNING

Electrical Shock Hazard Plug into a grounded 3 prong outlet. Do not remove ground prong. Do not use adaptor. Do not use an extension cord. Failure to follow these instructions can result in death, fire or electrical shock.