



# POWER AMPLIFIER

# P 7000S

# P 5000S

# P 3500S

# P 2500S

## Owner's Manual

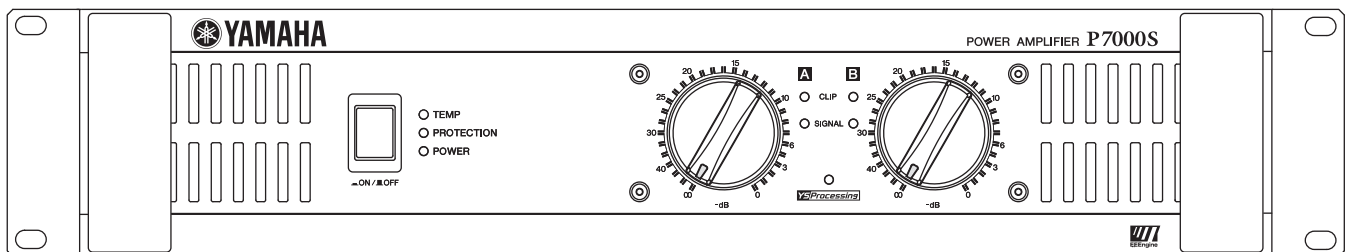

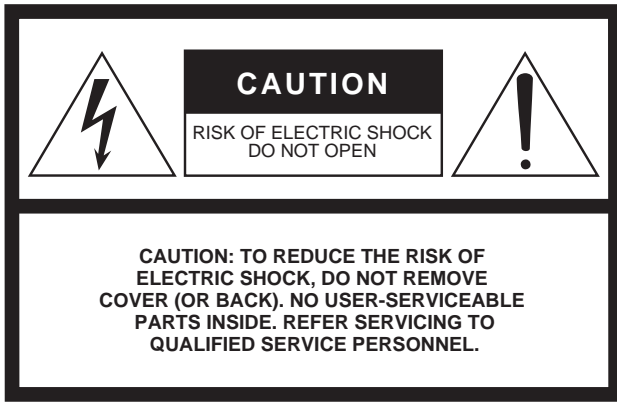

The above warning is located on the top of the unit

## • Explanation of Graphical Symbols

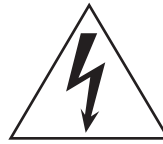

The lightning flash with arrowhead symbol within an equilateral triangle is intended to alert the user to the presence of uninsulated “dangerous voltage” within the product’s enclosure that may be of sufficient magnitude to constitute a risk of electric shock to persons.



The exclamation point within an equilateral triangle is intended to alert the user to the presence of important operating and maintenance (servicing) instructions in the literature accompanying the product.

# IMPORTANT SAFETY INSTRUCTIONS

- 1 Read these instructions.
- 2 Keep these instructions.
- 3 Heed all warnings.
- 4 Follow all instructions.
- 5 Do not use this apparatus near water.
- 6 Clean only with dry cloth.
- 7 Do not block any ventilation openings. Install in accordance with the manufacturer’s instructions.
- 8 Do not install near any heat sources such as radiators, heat registers, stoves, or other apparatus (including amplifiers) that produce heat.
- 9 Do not defeat the safety purpose of the polarized or grounding-type plug. A polarized plug has two blades with one wider than the other. A grounding type plug has two blades and a third grounding prong. The wide blade or the third prong are provided for your safety. If the provided plug does not fit into your outlet, consult an electrician for replacement of the obsolete outlet.
- 10 Protect the power cord from being walked on or pinched particularly at plugs, convenience

receptacles, and the point where they exit from the apparatus.

- 11 Only use attachments/accessories specified by the manufacturer.
- 12 Use only with the cart, stand, tripod, bracket, or table specified by the manufacturer, or sold with the apparatus. When a cart is used, use caution when moving the cart/apparatus combination to avoid injury from tip-over.
- 13 Unplug this apparatus during lightning storms or when unused for long periods of time.
- 14 Refer all servicing to qualified service personnel. Servicing is required when the apparatus has been damaged in any way, such as power-supply cord or plug is damaged, liquid has been spilled or objects have fallen into the apparatus, the apparatus has been exposed to rain or moisture, does not operate normally, or has been dropped.



### IMPORTANT NOTICE FOR THE UNITED KINGDOM Connecting the Plug and Cord

**WARNING:** THIS APPARATUS MUST BE EARTHED IMPORTANT. The wires in this mains lead are coloured in accordance with the following code:

GREEN-AND-YELLOW : EARTH  
BLUE : NEUTRAL  
BROWN : LIVE

As the colours of the wires in the mains lead of this apparatus may not correspond with the coloured markings identifying the terminals in your plug proceed as follows:

The wire which is coloured GREEN-and-YELLOW must be connected to the terminal in the plug which is marked by the letter E or by the safety earth symbol (⊕) or colored GREEN or GREEN-and-YELLOW. The wire which is coloured BLUE must be connected to the terminal which is marked with the letter N or coloured BLACK. The wire which is coloured BROWN must be connected to the terminal which is marked with the letter L or coloured RED.

### WARNING

TO REDUCE THE RISK OF FIRE OR ELECTRIC SHOCK, DO NOT EXPOSE THIS APPARATUS TO RAIN OR MOISTURE.

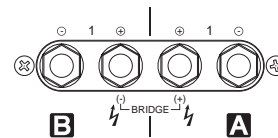

This ⚡ mark indicates a dangerous electrically live terminal. When connecting an external wire to this terminal, it is necessary either to have “a person who have received appropriate guidance on handling” make the connection or to use leads or a cord that have been manufactured in such a way that the connection can be made simply and without problem.

• This applies only to products distributed by Yamaha-Kemble Music (U.K.) Ltd. (3 wires)

# Precautions

— For safe operation —

## WARNING

### Installation

- Connect this unit's power cord only to an AC outlet of the type stated in this Owner's Manual or as marked on the unit. Failure to do so is a fire and electrical shock hazard.
- Do not allow water to enter this unit or allow the unit to become wet. Fire or electrical shock may result.
- Do not place a container with liquid or small metal objects on top of this unit. Liquid or metal objects inside this unit are a fire and electrical shock hazard.
- Do not place heavy objects, including this unit, on top of the power cord. A damaged power cord is a fire and electrical shock hazard. In particular, be careful not to place heavy objects on a power cord covered by a carpet.
- Be sure to connect to an appropriate outlet with a protective grounding connection. Improper grounding can result in electrical shock.

### Operation

- Do not scratch, bend, twist, pull, or heat the power cord. A damaged power cord is a fire and electrical shock hazard.
- Do not remove the unit's cover. You could receive an electrical shock. If you think internal inspection, maintenance, or repair is necessary, contact your dealer.

- Do not modify the unit. Doing so is a fire and electrical shock hazard.
- If lightning begins to occur, turn off the power switch of the unit as soon as possible, and unplug the power cable plug from the electrical outlet.
- If there is a possibility of lightning, do not touch the power cable plug if it is still connected. Doing so may be an electrical shock hazard.

### In case an abnormality occurs during operation

- If the power cord is damaged (i.e., cut or a bare wire is exposed), ask your dealer for a replacement. Using the unit with a damaged power cord is a fire and electrical shock hazard.
- Should this unit be dropped or the cabinet be damaged, turn the power switch off, remove the power plug from the AC outlet, and contact your dealer. If you continue using the unit without heeding this instruction, fire or electrical shock may result.
- If you notice any abnormality, such as smoke, odor, or noise, or if a foreign object or liquid gets inside the unit, turn it off immediately. Remove the power cord from the AC outlet. Consult your dealer for repair. Using the unit in this condition is a fire and electrical shock hazard.

## CAUTION

### Installation

- Keep this unit away from the following locations:
  - Locations exposed to oil splashes or steam, such as near cooking stoves, humidifiers, etc.
  - Unstable surfaces, such as a wobbly table or slope.
  - Locations exposed to excessive heat, such as inside a car with all the windows closed, or places that receive direct sunlight.
  - Locations subject to excessive humidity or dust accumulation.
- Do not place the power cord close to a heater. It may melt, causing fire or electrical shock.
- Hold the power cord plug when disconnecting it from an AC outlet. Never pull the cord. A damaged power cord is a potential fire and electrical shock hazard.
- Do not touch the power plug with wet hands. Doing so is a potential electrical shock hazard.
- This unit has ventilation holes at the front and rear to prevent the internal temperature rising too high. Do not block them. Blocked ventilation holes are a fire hazard. In particular, do not
  - place the unit on its side or upside down,
  - place the unit in any poorly-ventilated location such as a bookcase or closet (other than on the dedicated rack),
  - cover the unit with a table cloth or place it on a carpet or bed.
- Allow enough free space around the unit for normal ventilation. This should be: 5 cm at the sides, 10 cm behind, and 10 cm above. If the airflow is not adequate, the unit will heat up inside and may cause a fire.
- To mount several of these units in a standard EIA rack, refer to the rack mounting instructions on page 11.

- To relocate the unit, turn the power switch off, remove the power plug from the AC outlet, and remove all connecting cables. Damaged cables may cause fire or electrical shock.
- When setting up the product, make sure that the AC outlet you are using is easily accessible. If some trouble or malfunction occurs, immediately turn off the power switch and disconnect the plug from the outlet. Even when the power switch is turned off, electricity is still flowing to the product at the minimum level. When you are not using the product for a long time, make sure to unplug the power cord from the wall AC outlet.
- Do not place the device in a location where it may come into contact with corrosive gases or salt air. Doing so may result in malfunction.

### Operation

- Use only speaker cables when connecting speakers to amplifier outputs. Using other types of cables is a fire hazard.
- Turn off all musical instruments, audio equipment, and speakers when connecting to this unit. Use the correct connecting cables and connect as specified.
- Always lower the volume control to minimum before turning on the power to this unit. A sudden blast of sound may damage your hearing.
- Do not use this amplifier for any purpose other than driving loudspeakers.
- If you know you will not use this unit for a long period of time, such as when going on vacation, remove the power plug from the AC outlet. Leaving it connected is a potential fire hazard.

---

## — For correct operation —

### Connector pin assignments

- XLR-type connectors are wired as follows  
Pin 1: ground; Pin 2: hot (+); Pin 3: cold (-).

### Interference from Cell Phones

- Use of a mobile phone near this unit may induce noise. If noise occurs, move the phone further from the unit.

Always turn the power off when the amplifier is not in use.

Illustrations in this manual are for explanatory purposes only, and may not match the actual appearance of the product during operation.

Company names and product names used in this Owner's Manual are trademarks or registered trademarks of their respective owners.

## FCC INFORMATION (U.S.A.)

### 1. IMPORTANT NOTICE: DO NOT MODIFY THIS UNIT!

This product, when installed as indicated in the instructions contained in this manual, meets FCC requirements. Modifications not expressly approved by Yamaha may void your authority, granted by the FCC, to use the product.

- ### 2. IMPORTANT:
- When connecting this product to accessories and/or another product use only high quality shielded cables. Cable/s supplied with this product **MUST** be used. Follow all installation instructions. Failure to follow instructions could void your FCC authorization to use this product in the USA.

\* This applies only to products (P7000S, P5000S) distributed by YAMAHA CORPORATION OF AMERICA.

# Introduction

---

Thank you for your purchase of the YAMAHA P7000S, P5000S, P3500S or P2500S power amplifier. These P-series amplifiers fully incorporate Yamaha's renown technological expertise, and offer high reliability, rock-solid stability, and superb acoustic characteristics—all in a trim, 2U-sized package.

## *Features*

- With two types of input jacks (balanced XLR and balanced phone) and three types of output jacks (Speakon, 5-way binding post, and phone), the P series is suitable for a wide variety of applications and installed systems.
- The unit offers three operating modes: STEREO (where Channels A and B operate independently), PARALLEL (where the unit outputs a mono source through twin amplifier systems), and BRIDGE (where the unit operates as a single high-power amp).
- Each channel is equipped with an independent OFF/LOW CUT/SUBWOOFER switch—where LOW CUT engages a high-pass filter, and SUBWOOFER engages a low-pass filter. With LOW CUT or SUBWOOFER selected, you can adjust the cutoff frequency from 25 to 150 Hz.
- Each channel has its own SIGNAL and CLIP indicators.
- The PROTECTION indicator lights up—and sound output is automatically muted—whenever the unit's protective circuitry is operating. The TEMP indicator lights up if the unit is running hot.
- Variable-speed low-noise fans ensure high reliability.

This Owner's Manual covers the four models: P7000S, P5000S, P3500S and P2500S power amplifiers. Please read through this manual carefully before beginning use, so that you will be able to take full advantage of the amplifier's superlative features and enjoy trouble-free operation for years to come. After reading through the manual, please store it in a safe place.

## **Contents**

---

Controls and Functions .....	6
Front Panel .....	6
Rear Panel .....	7
Speaker Connections .....	9
Speaker impedance .....	9
Wiring .....	10
Rack Mounting .....	11
Specifications .....	12
General Specifications .....	12
Block Diagram .....	13
Dimensions .....	14
Current Draw .....	14
Troubleshooting .....	15

# Controls and Functions

## ■ Front Panel

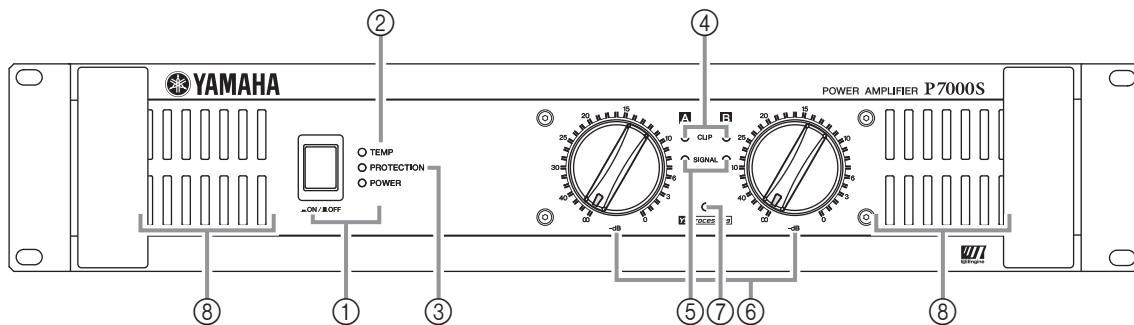

### ① POWER switch and indicator

Press to toggle the power on or off. The POWER indicator lights up green when the power is ON.

### ② TEMP indicator

Lights up red if the heat sink temperature exceeds 85°C (185°F).

### ③ PROTECTION indicator

Lights up red to indicate that protection is in effect. Specifically, lights up if the heat sink overheats, or if a DC voltage is detected at the amplifier outputs. Also lights up for about three seconds at time of power-on, as the amp gets ready to operate. To provide protection, the unit will not output any sound from the speakers while this indicator is lit up. When start-up is completed or the problem is corrected, the indicator goes off and normal operation resumes.

### ④ CLIP indicator

Lights up red when the output signal distortion on the corresponding channel rises above 1%—indicating that “clipping” has occurred because the signal level is too high.

### ⑤ SIGNAL indicator

Lights up green when the corresponding channel’s output level exceeds 2 V<sub>rms</sub> (equivalent to 1/2 W into an 8 Ω load, or 1 W into a 4 Ω load).

### ⑥ Volume control knobs

Each control knob adjusts the volume of the corresponding channel, in 31 steps from  $-\infty$  dB to 0 dB.

#### NOTE:

If you wish to lock in the knob settings, you can fasten the supplied security cover over the knobs so that the settings will not be disturbed.

#### How to install the security cover

- (1) Use the supplied hex wrench to remove the four attachment screws from the amplifier.
- (2) Adjust the security cover to the position of screw holes. Fasten it into place using the same screws.

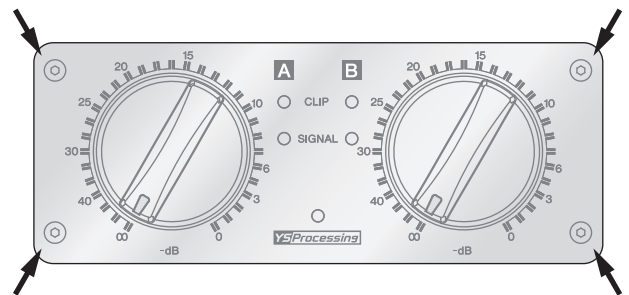

### ⑦ **YSProcessing** indicator

Lights up yellow if the YS PROCESSING switch on the rear panel is set ON. (See page 7.)

### ⑧ Air intakes

The amplifier uses forced-air cooling. The cooling fans draw air in from the front and exhaust it through the rear. Please be sure that you do not block the air intakes or exhaust vents.

#### NOTE:

The fans do not come on at initial power-on, but will switch on automatically when the temperature of the heat sink rises above 50°C (122°F). The fan speed will then vary automatically as the temperature changes.

## ■ Rear Panel

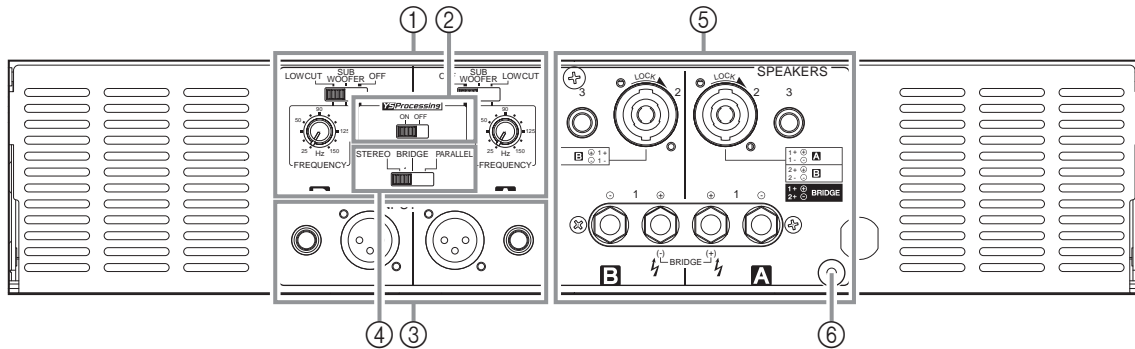

### ① FILTER switch and FREQUENCY adjustment knob (One pair for each channel)

Use these controls to select the filter type and adjust the cutoff frequency on each channel (A and B). You use the FILTER switch to select the filter, as follows.



OFF ..... Do not use any filter.

SUBWOOFER..... Use a low-pass filter. The amplifier outputs the frequencies that are lower than the cut-off set by the FREQUENCY adjustment knob.

LOW CUT ..... Use a high-pass filter. You can use this setting to filter out unneeded low or subsonic frequencies.

If you select SUBWOOFER or LOW CUT, you can then use the FREQUENCY adjustment knob to adjust the cutoff frequency. The adjustment range is 25 Hz to 150 Hz.

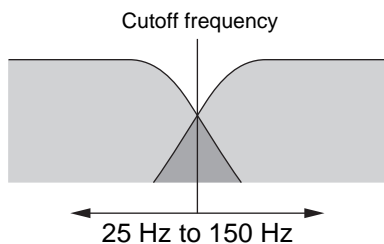

#### NOTE:

If the amplifier is set to BRIDGE mode, only the switch and knob for Channel A are effective. (The Channel B frequency controls are disabled.)

### ② **YSProcessing** ON/OFF switch

If you set this switch ON, the amplifier adds low-frequency compensation so as to enhance speaker output. The results (the actual change in the low-frequency balance) will vary according to the speaker type. Note that this switch is effective only if the FILTER switch is set to OFF.

#### NOTE:

This feature provides improved frequency response on speakers such as the YAMAHA S112 and S115.

### ③ INPUT jacks (Channels A, B)

Two jack types are provided for each channel. Note that if you are using BRIDGE or PARALLEL mode, only the Channel A jacks are effective.

#### • XLR-3-31 jack

The XLR-3-31 input jacks are wired as shown below.

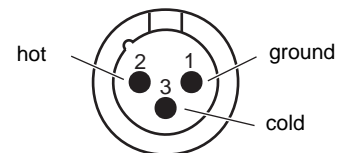

#### • Phone jack

Phone jacks are wired as follows.

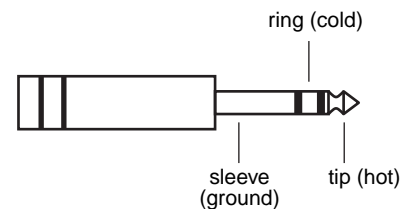

---

④ **STEREO/PARALLEL/BRIDGE switch**

Use this switch to select the operating mode.

- **STEREO mode**

Channels A and B operate independently (as with a conventional stereo amplifier). The Channel A input goes to the Channel A output jacks, and the Channel B input goes to the Channel B output jacks.

- **PARALLEL mode**

The Channel A input signal is output through both the Channel A and Channel B output jacks. The Channel B input jacks do not function. Channel A and B volumes can be independently adjusted.

- **BRIDGE mode**

The Channel A input signal is output from the BRIDGE output jacks. To adjust the volume, you must use the Channel A volume control knob.

⑤ **SPEAKER jacks**

Neutrik NL4FC Speakon output connectors,  
5-way binding post output jacks,  
Phone output jacks

For minimum speaker impedance values, see page 9.

⑥ **GND terminal**

This is a screw-type ground terminal. If you are having a problem with hum or noise, use this terminal to connect to ground or to connect to the chassis of the mixer, preamp, or other device in your system.



# Speaker Connections

## ■ Speaker impedance

Speakers can be connected to the amplifier as shown below. Note that speaker impedance will vary according to the connection method and the number of speakers. Please be sure that your speakers' impedance is not less than the relevant minimum value indicated below.

### Connection configurations for STEREO and PARALLEL modes

When using 5-way binding post output jacks

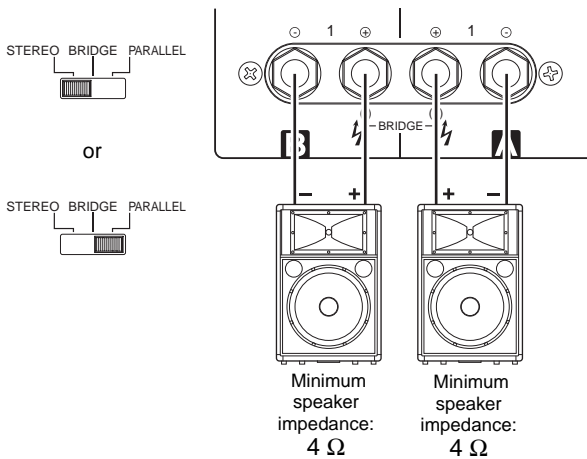

### Connection configurations for BRIDGE mode

When using 5-way binding post output jacks

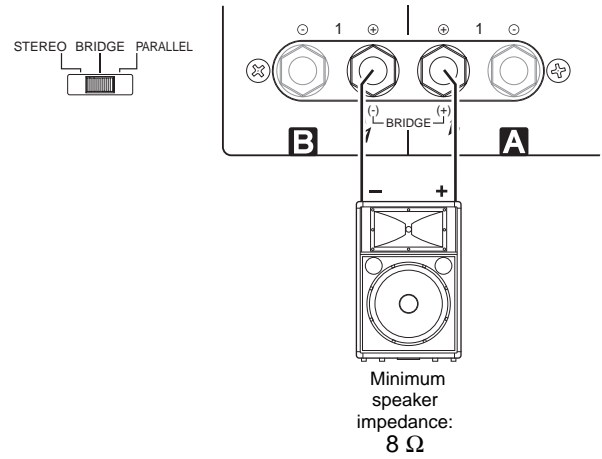

When using Speakon connector

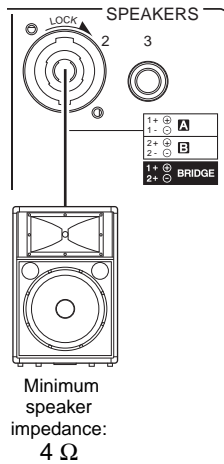

When using Speakon connector

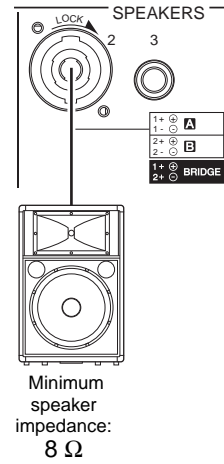

When using phone jack

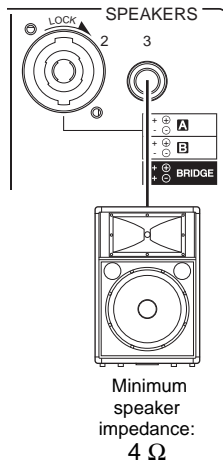

## ■ Wiring

### 5-way binding post

- (1) Turn off the POWER switch.
- (2) Remove the cover attachment screws and remove the protective cover from the speaker terminals.



- (3) Remove about 15 mm of insulation from the end of each speaker cable, and pass the bare wire through the holes in the appropriate speaker terminals. Tighten the terminals to securely clamp the wires. Refer to page 9 for speaker polarities.

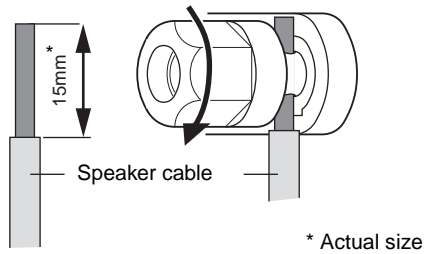

Note to users in the USA:  
Please use Class 3 wiring. (P7000S, P5000S)  
Please use Class 2 wiring. (P3500S, P2500S)

Be sure that the bare wire ends do not jut out from the terminals and touch the chassis. The following shows how the cable should look when correctly attached.

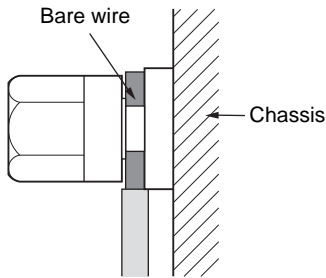

- (4) Reattach the protective cover over the speaker terminals.

### Speakon connector

- (1) Turn off the POWER switch.
- (2) Insert the Neutrik NL4FC plugs into the Speakon connector on the rear of the amplifier, and turn clockwise to lock.

#### Neutrik NL4FC plugs

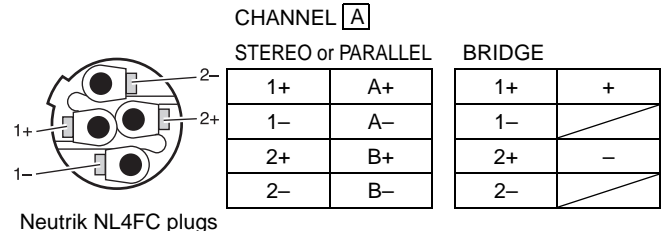

CHANNEL **B**

1+	B+
1-	B-

### Phone jack

- (1) Turn off the POWER switch.
- (2) Insert the phone plug into the jack on the rear of the amplifier.

# Rack Mounting

## Mounting in a standard EIA rack

If you are mounting multiple power amplifiers in a rack, be sure to install ventilation panel(s) as shown below. Also be sure to use metal brackets (one on each side) to support the rear of each amplifier.

Note: EIA stands for Electronic Industries Alliance.

## Ventilation panel(s)

Use 1U-size blank panel(s).

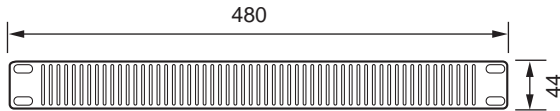

Unit: mm

## If mounting up to four amplifiers in an open-backed rack

Install a ventilation panel as shown below.

Ventilation panel  
(Attach to the front  
or rear of the rack.)

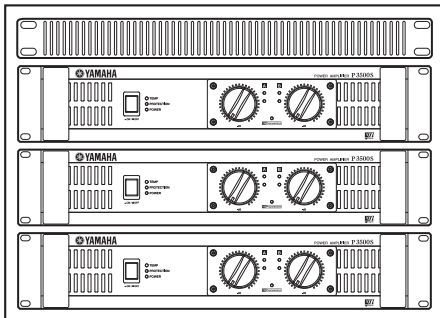

## When mounting five or more amplifiers in an open-backed rack, and when mounting any number of amplifiers in a close-backed rack

Install ventilation panels above and below each amplifier, as shown below.

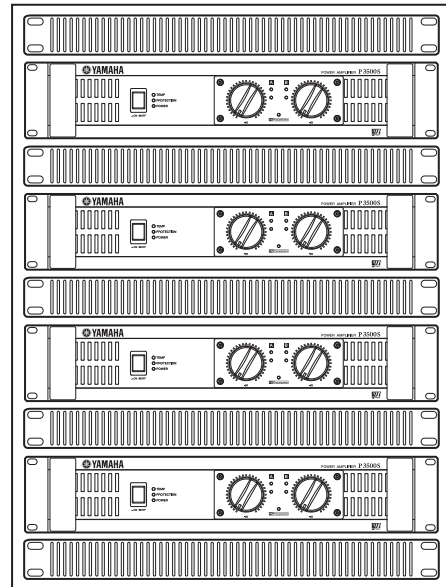

# Specifications

## ■ General Specifications

		P7000S	P5000S	P3500S	P2500S
Power Output Level (Rated Power)	8 Ω/STEREO	750 W × 2	525 W × 2	390 W × 2	275 W × 2
	4 Ω/STEREO	1100 W × 2	750 W × 2	590 W × 2	390 W × 2
1 kHz THD + N = 1%	8 Ω/BRIDGE	2200 W × 1	1500 W × 1	1180 W × 1	780 W × 1
	8 Ω/STEREO	700 W × 2	500 W × 2	350 W × 2	250 W × 2
20 Hz – 20 kHz THD + N = 0.1%	4 Ω/STEREO	650 W × 2 (European Model)	700 W × 2	450 W × 2	310 W × 2
	8 Ω/BRIDGE	1900 W × 1	1400 W × 1	900 W × 1	620 W × 1
1 kHz 20 ms non-clip	2 Ω/STEREO	1600 W × 2	1300 W × 2	1000 W × 2	650 W × 2
	4 Ω/BRIDGE	3200 W × 1	2600 W × 1	2000 W × 1	1300 W × 1
Power Bandwidth	Half Power	10 Hz – 40 kHz (THD + N = 0.5 %)			
Total Harmonic Distortion (THD + N) 20 Hz – 20 kHz, Half Power	4 Ω – 8 Ω/STEREO	≅ 0.1 %			
	8 Ω/BRIDGE				
Frequency Response	RL = 8 Ω, Po = 1 W 20 Hz – 50 kHz	+0 dB, –1.5 dB			
Intermodulation Distortion (IMD) 60 Hz:7 kHz, 4:1, Half Power	4 Ω – 8 Ω/STEREO	≅ 0.1 %			
	8 Ω/BRIDGE				
Channel Separation Vol. max	Half Power RL = 8 Ω 1 kHz input 600 Ω shunt	≧ 70 dB			
	Vol. min.				
Residual Noise	20 Hz – 20 kHz (DIN AUDIO)	≅ –70 dBu			
SN Ratio	20 Hz – 20 kHz (DIN AUDIO)	104 dB	103 dB	102 dB	100 dB
Damping Factor	RL = 8 Ω, 1 kHz	≧ 350		≧ 200	
Input Sensitivity	RL = 8 Ω	+8.0 dBu	+6.4 dBu	+5.2 dBu	+3.6 dBu
	(1 kHz, THD + N = 1 %)				
Voltage Gain	RL = 8 Ω	32 dB			
Input Impedance		30 kΩ/balanced, 15 kΩ/unbalanced			
Controls	Front Panel	POWER switch (Push on/Push off) Two 31-step Volume control knobs (one per ch)			
	Rear Panel	MODE switch (STEREO/PARALLEL/BRIDGE) Two FILTER switches (SUBWOOFER/LOW CUT/OFF) Two fc knobs (25 to 150 Hz, 12 dB/octave) YS Processing switch (ON/OFF)			
Connectors	INPUT	XLR-3-31 jacks (one per ch) 1/4-inch TRS phone jacks (one per ch)			
	OUTPUT	Speakon jacks (one per ch) 5-way binding posts 1/4-inch phone jacks (one per ch)			
Indicators	POWER	× 1 (Green)			
	PROTECTION	× 1 (Red)			
	TEMP	× 1 (Red) (heatsink temp ≧ 85°C)			
	CLIP	× 2 (Red)			
	SIGNAL	× 2 (Green)			
	YS Processing	× 1 (Yellow)			
Load Protection		POWER switch ON/OFF muting			
		DC-fault power supply shutdown		DC detection	
Amp. Protection		Temp. detection (heat sink temp ≧ 90°C), VI limiter (RL ≦ 1 Ω)			
Limiter		Comp: THD ≧ 0.5 %			
Cooling		Dual variable-speed fan		Single variable-speed fan	
Power Requirements		120 V, 220 V – 240 V; 50 Hz/60 Hz			
Power Consumption	Idling	35 W	35 W	30 W	25 W
	Output power, 4 Ω	650 W	500 W	450 W	320 W
Dimensions (W × H × D)		480 × 88 × 456 mm (18-7/8" × 3-7/16" × 17-15/16")			
Weight		12.0 kg (26.5 lbs)	12.0 kg (26.5 lbs)	15.0 kg (33.1 lbs)	14.0 kg (30.9 lbs)
Included Accessories		Security cover (with a hex wrench), Owner's Manual			

0 dBu=0.775 Vrms, Half Power=1/2 Power Output Level (Rated Power)

Specifications and descriptions in this owner's manual are for information purposes only. Yamaha Corp. reserves the right to change or modify products or specifications at any time without prior notice. Since specifications, equipment or options may not be the same in every locale, please check with your Yamaha dealer.

European models

Purchaser/User Information specified in EN55103-1 and EN55103-2.

Inrush Current: 25A (P7000S, P5000S)/66A (P3500S)/68A (P2500S)

Conforms to Environments: E1, E2, E3 and E4

# Block Diagram

## P7000S, P5000S

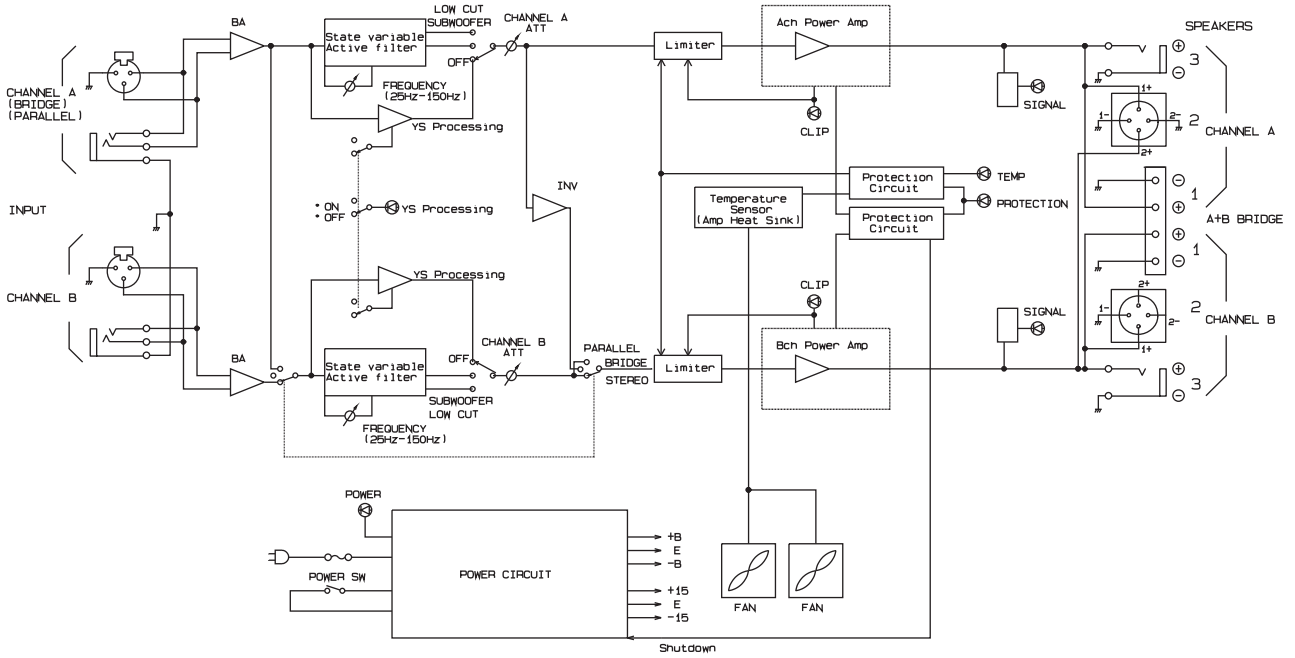

## P3500S, P2500S

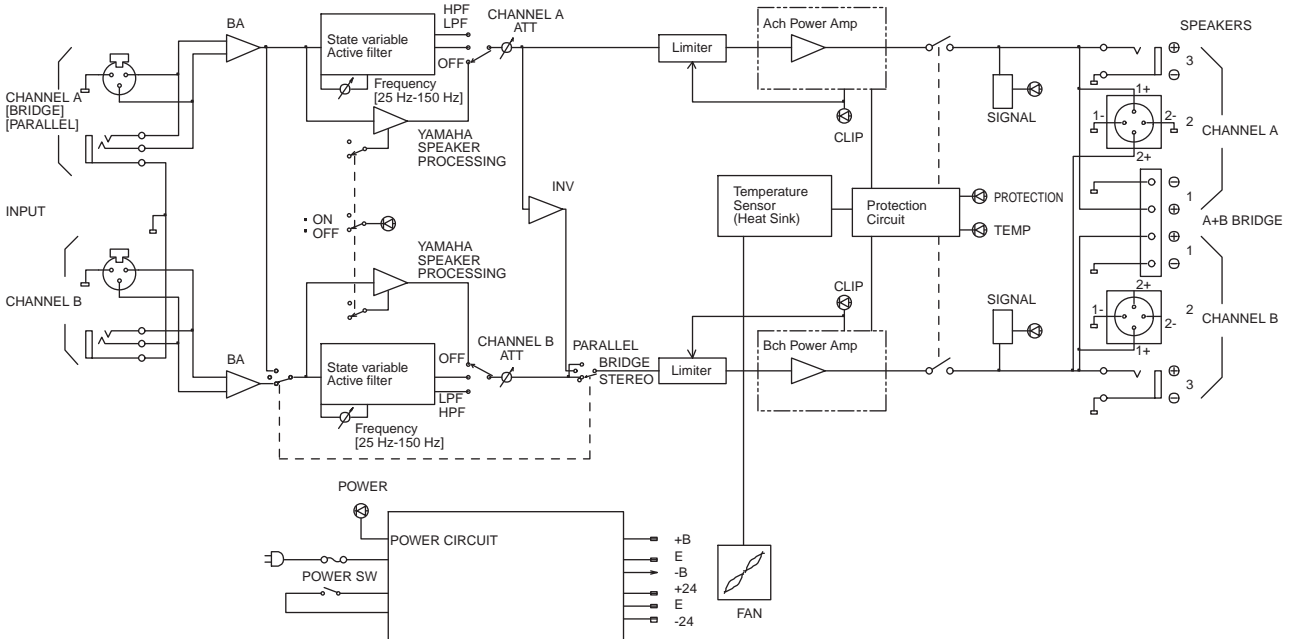

## ■ Dimensions

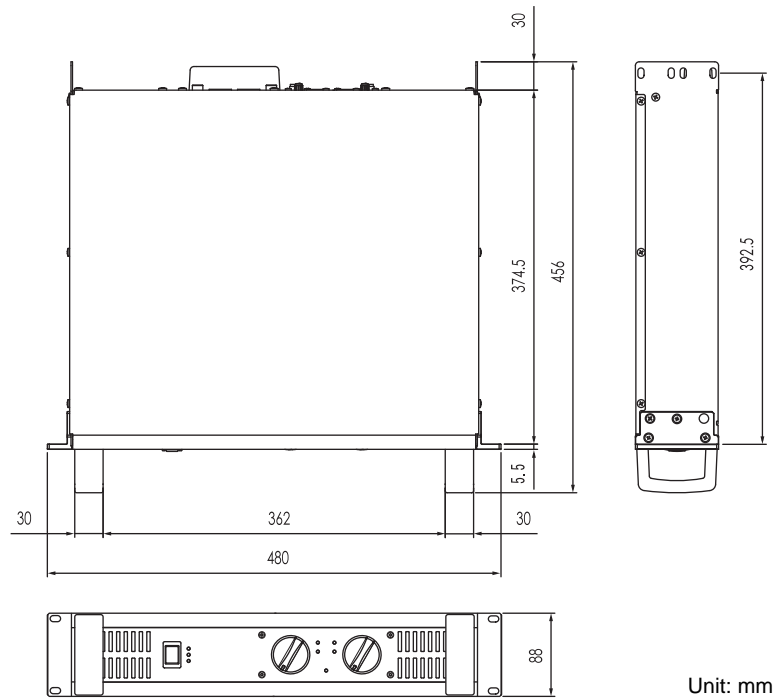

## ■ Current Draw

### P7000S

		Line Current (A)		Power (W)			Thermal Dissipation	
		100/120V	230/240V	In	Out	Dissipated	Btu/h	kcal/h
standby		0.08	0.04	5	0	5	17	4
idle		1.0	0.5	35	0	35	119	30
1/8 power	8Ω/ch	5.4	3.0	379	188	191	653	165
	4Ω/ch	8.5	4.7	611	275	336	1150	289
1/3 power	8Ω/ch	12.8	7.0	918	500	418	1430	360
	4Ω/ch	20.6	11.3	1481	733	748	2550	643

### P5000S

		Line Current (A)		Power (W)			Thermal Dissipation	
		100/120V	230/240V	In	Out	Dissipated	Btu/h	kcal/h
standby		0.08	0.04	5	0	5	17	4
idle		1.0	0.5	35	0	35	119	30
1/8 power	8Ω/ch	4.0	2.2	277	131	146	499	126
	4Ω/ch	6.2	3.4	436	188	249	848	214
1/3 power	8Ω/ch	9.3	5.1	673	350	323	1100	278
	4Ω/ch	14.7	8.1	1057	500	557	1900	479

### P3500S

		Line Current (A)		Power (W)			Thermal Dissipation	
		100/120V	230/240V	In	Out	Dissipated	Btu/h	kcal/h
standby		0.08	0.04	5	0	5	17	4
idle		1.0	0.5	30	0	30	102	26
1/8 power	8Ω/ch	3.2	1.7	227	98	130	443	112
	4Ω/ch	5.0	2.8	378	148	231	787	198
1/3 power	8Ω/ch	7.3	4.0	551	260	291	993	250
	4Ω/ch	12.2	6.7	917	393	524	1790	450

## P2500S

	Line Current (A)		Power (W)			Thermal Dissipation		
	100/120V	230/240V	In	Out	Dissipated	Btu/h	kcal/h	
standby	0.08	0.04	5	0	5	17	4	
idle	1.0	0.5	25	0	25	85	22	
1/8 power	8Ω/ch	2.4	1.3	174	69	105	358	90
	4Ω/ch	3.6	2.0	271	98	173	592	149
1/3 power	8Ω/ch	5.6	3.1	421	183	238	811	204
	4Ω/ch	8.8	4.8	657	260	397	1350	341

1/8 power is typical of program material with occasional clipping. Refer to these figures for most applications.

1/3 power represents program material with extremely heavy clipping.

Test signal: Pink Noise, bandwidth limited from 22Hz to 22kHz

1W = 0.860kcal/h, 1BTU = 0.252kcal

Note that Line Voltage [V] x Line Current [A] = [VA], not equals to [W].

Inrush current

P7000S, P5000S: 11A (100V), 13A (120V), 25A (240V)

P3500S: 142A (100V), 170A (120V), 66A (240V)

P2500S: 103A (100V), 150A (120V), 68A (240V)

# Troubleshooting

The following table lists the main causes of abnormal operation and the corrective measures required, as well as the protective circuit operation in each case.

Indicator(s)	Possible Cause	Remedy	Protection Circuit
CLIP indicator lights.	There is a short at a speaker terminal, amplifier terminal, or wire.	Locate and correct the cause of the short.	The PC limiter circuit operates to protect the power transistors.
	The amplifier load is excessive.	Use a speaker system with an impedance of at least 4 Ω (STEREO/PARALLEL mode) or 8 Ω (BRIDGE mode).	
TEMP indicator lights.	The heat sink temperature has exceeded 85°C (185°F).	Check the ventilation slots, and provide better airflow around the amplifier.	The TEMP indicator lights up to indicate temperature warning.
PROTECTION indicator lights.	The heat sink temperature has exceeded 95°C (203°F).	Check the amplifier ventilation conditions and take appropriate measures to improve the airflow around the amplifier.	The thermal protection circuit operates to protect the power transistors.

## P3500S, P2500S

Indicator(s)	Possible Cause	Remedy	Protection Circuit
PROTECTION indicator lights.	A DC voltage of ±2 V or greater was generated in the power amplifier's output circuit.	Consult your dealer or the nearest Yamaha service center.	The relay operates to protect the speaker system.

## P7000S, P5000S

Indicator(s)	Possible Cause	Remedy	Protection Circuit
Power has been shut down. (All indicators are off.)	A DC voltage of ± 2 V or greater was generated in the power amplifier's output circuit.	Consult your dealer or the nearest Yamaha service center.	The protection circuitry shut off the power to protect the speaker system.

For details of products, please contact your nearest Yamaha representative or the authorized distributor listed below.

Pour plus de détails sur les produits, veuillez-vous adresser à Yamaha ou au distributeur le plus proche de vous figurant dans la liste suivante.

Die Einzelheiten zu Produkten sind bei Ihrer unten aufgeführten Niederlassung und bei Yamaha Vertragshändlern in den jeweiligen Bestimmungsländern erhältlich.

Para detalles sobre productos, contacte su tienda Yamaha más cercana o el distribuidor autorizado que se lista debajo.

## NORTH AMERICA

### CANADA

**Yamaha Canada Music Ltd.**  
135 Milner Avenue, Toronto, Ontario,  
M1S 3R1, Canada  
Tel: 416-298-1311

### U.S.A.

**Yamaha Corporation of America**  
6600 Orangethorpe Avenue, Buena Park, CA 90620,  
U.S.A.  
Tel: 714-522-9011

## CENTRAL & SOUTH AMERICA

### MEXICO

**Yamaha de México, S.A. de C.V.**  
Av. Insurgentes Sur 1647 Piso 9, Col. San José  
Insurgentes, Delegación Benito Juárez, México,  
D.F., C.P. 03900  
Tel: 55-5804-0600

### BRAZIL

**Yamaha Musical do Brasil Ltda.**  
Rua Joaquim Floriano, 913 - 4º andar, Itaim Bibi,  
CEP 04534-013 São Paulo, SP. BRAZIL  
Tel: 011-3704-1377

### ARGENTINA

**Yamaha Music Latin America, S.A.,  
Sucursal Argentina**  
Olga Cossetini 1553, Piso 4 Norte,  
Madero Este-C1107CEK  
Buenos Aires, Argentina  
Tel: 011-4119-7000

### VENEZUELA

**Yamaha Music Latin America, S.A.,  
Sucursal Venezuela**  
C.C. Manzanera Plaza P4  
Ofic. 0401- Manzanera-Baruta  
Caracas Venezuela  
Tel: 58-212-943-1877

### PANAMA AND OTHER LATIN AMERICAN COUNTRIES/ CARIBBEAN COUNTRIES

**Yamaha Music Latin America, S.A.**  
Torre Banco General, Piso No.7, Marbella,  
Calle 47 y Aquilino de la Guardia,  
Ciudad de Panamá, República de Panamá  
Tel: +507-269-5311

## EUROPE

### THE UNITED KINGDOM/IRELAND

**Yamaha Music Europe GmbH (UK)**  
Sherbourne Drive, Tilbrook, Milton Keynes,  
MK7 8BL, U.K.  
Tel: 01908-366700

### GERMANY

**Yamaha Music Europe GmbH**  
Siemensstraße 22-34, 25462 Rellingen, Germany  
Tel: 04101-3030

### SWITZERLAND/LIECHTENSTEIN

**Yamaha Music Europe GmbH  
Branch Switzerland in Zürich**  
Seefeldstrasse 94, 8008 Zürich, Switzerland  
Tel: 044-387-8080

### AUSTRIA/BULGARIA

**Yamaha Music Europe GmbH Branch Austria**  
Schleiergasse 20, A-1100 Wien, Austria  
Tel: 01-60203900

### CZECH REPUBLIC/HUNGARY/ ROMANIA/SLOVAKIA/SLOVENIA

**Yamaha Music Europe GmbH  
Branch Austria (Central Eastern Europe Office)**  
Schleiergasse 20, A-1100 Wien, Austria  
Tel: 01-60203900

### POLAND/LITHUANIA/LATVIA/ESTONIA

**Yamaha Music Europe GmbH  
Branch Poland Office**  
ul. Wrotkowa 14 02-553 Warsaw, Poland  
Tel: 022-500-2925

### MALTA

**Olimpus Music Ltd.**  
The Emporium, Level 3, St. Louis Street Msida  
MSD06  
Tel: 02133-2144

### NETHERLANDS/BELGIUM/ LUXEMBOURG

**Yamaha Music Europe Branch Benelux**  
Clarissenhof 5-b, 4133 AB Vianen, Netherlands  
Tel: 0347-358 040

### FRANCE

**Yamaha Music Europe**  
7 rue Ambroise Croizat, Zone d'activités Pariest,  
77183 Croissy-Beaubourg, France  
Tel: 01-64-61-4000

### ITALY

**Yamaha Music Europe GmbH, Branch Italy**  
Viale Italia 88, 20020 Lainate (Milano), Italy  
Tel: 02-935-771

### SPAIN/PORTUGAL

**Yamaha Music Europe GmbH Ibérica, Sucursal  
en España**  
Ctra. de la Coruna km. 17,200, 28231  
Las Rozas (Madrid), Spain  
Tel: +34-91-639-88-88

### GREECE

**Philippos Nakas S.A. The Music House**  
147 Skiathou Street, 112-55 Athens, Greece  
Tel: 01-228 2160

### SWEDEN/FINLAND/ICELAND

**Yamaha Music Europe GmbH Germany filial  
Scandinavia**  
JA Wettergrensgata 1, Västra Frölunda, Sweden  
Tel: +46 31 89 34 00

### DENMARK

**Yamaha Music Europe GmbH, Tyskland – filial  
Denmark**  
Generatorvej 8B, DK-2730 Herlev, Denmark  
Tel: 44 92 49 00

### NORWAY

**Yamaha Music Europe GmbH Germany -  
Norwegian Branch**  
Grini Næringspark 1, N-1361 Østerås, Norway  
Tel: 67 16 78 00

### RUSSIA

**Yamaha Music (Russia) LLC.**  
Room 37, bld. 7, Kievskaya street, Moscow,  
121059, Russia  
Tel: 495 626 5005

### OTHER EUROPEAN COUNTRIES

**Yamaha Music Europe GmbH**  
Siemensstraße 22-34, 25462 Rellingen, Germany  
Tel: +49-4101-3030

## AFRICA

**Yamaha Music Gulf FZE**  
Office JAFZA 16-512, P.O.Box 17328,  
Jebel Ali - Dubai, UAE  
Tel: +971-4-881-5868

## MIDDLE EAST

### TURKEY

**Yamaha Music Europe GmbH**  
Merkezi Almanya Türkiye İstanbul Şubesi  
Maslak Meydan Sokak No:5 Spring Giz Plaza  
Bağışsız Böl. No:3, 34398 Şişli İstanbul  
Tel: +90-212-999-8010

### CYPRUS

**Yamaha Music Europe GmbH**  
Siemensstraße 22-34, 25462 Rellingen, Germany  
Tel: 04101-3030

### OTHER COUNTRIES

**Yamaha Music Gulf FZE**  
Office JAFZA 16-512, P.O.Box 17328,  
Jebel Ali - Dubai, U.A.E  
Tel: +971-4-881-5868

## ASIA

### THE PEOPLE'S REPUBLIC OF CHINA

**Yamaha Music & Electronics (China) Co.,Ltd.**  
2F, Yunhedasha, 1818 Xinzha-lu, Jingan-qu,  
Shanghai, China  
Tel: 400-051-7700

### INDIA

**Yamaha Music India Pvt. Ltd.**  
Spazedge building, Ground Floor, Tower A, Sector  
47, Gurgaon- Sohna Road, Gurgaon, Haryana, India  
Tel: 0124-485-3300

### INDONESIA

**PT. Yamaha Musik Indonesia (Distributor)**  
Yamaha Music Center Bldg. Jalan Jend. Gatot  
Subroto Kav. 4, Jakarta 12930, Indonesia  
Tel: 021-520-2577

### KOREA

**Yamaha Music Korea Ltd.**  
8F, 9F, Dongsung Bldg. 158-9 Samsung-Dong,  
Kangnam-Gu, Seoul, Korea  
Tel: 02-3467-3300

### MALAYSIA

**Yamaha Music (Malaysia) Sdn., Bhd.**  
No.8, Jalan Perbandaran, Kelana Jaya, 47301  
Petaling Jaya, Selangor, Malaysia  
Tel: 03-78030900

### SINGAPORE

**Yamaha Music (Asia) Private Limited**  
Block 202 Hougang Street 21, #02-00,  
Singapore 530202, Singapore  
Tel: 65-6747-4374

### TAIWAN

**Yamaha Music & Electronics Taiwan Co.,Ltd.**  
3F, No.6, Section 2 Nan-Jing East Road, Taipei,  
Taiwan R.O.C.  
Tel: 02-2511-8688

### THAILAND

**Siam Music Yamaha Co., Ltd.**  
3, 4, 15 and 16th floor, Siam Motors Building,  
891/1 Rama 1 Road, Wangmai,  
Pathumwan, Bangkok 10330, Thailand  
Tel: 02-215-2622

### VIETNAM

**Yamaha Music Vietnam Company Limited**  
15th Floor, Nam A Bank Tower, 201-203 Cach  
Mang Thang Tam St., Ward 4, Dist.3,  
Ho Chi Minh City, Vietnam  
Tel: +84-8-3818-1122

### OTHER ASIAN COUNTRIES

**Yamaha Corporation  
Sales & Marketing Division**  
Nakazawa-cho 10-1, Naka-ku, Hamamatsu,  
Japan 430-8650  
Tel: +81-53-460-2312

## OCEANIA

### AUSTRALIA

**Yamaha Music Australia Pty. Ltd.**  
Level 1, 99 Queensbridge Street, Southbank,  
Victoria 3006, Australia  
Tel: 3-9693-5111

### COUNTRIES AND TRUST TERRITORIES IN PACIFIC OCEAN

**Yamaha Corporation  
Sales & Marketing Division**  
Nakazawa-cho 10-1, Naka-ku, Hamamatsu,  
Japan 430-8650  
Tel: +81-53-460-2312