



R-S700/R-S500

Receiver

OWNER'S MANUAL

IMPORTANT SAFETY INSTRUCTIONS

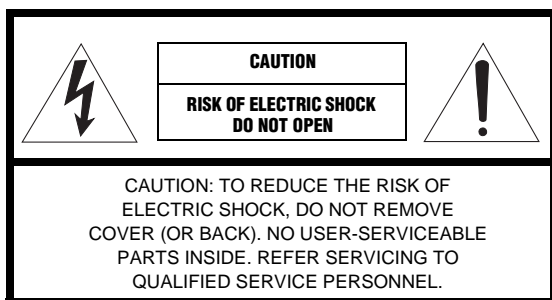

• Explanation of Graphical Symbols



The lightning flash with arrowhead symbol, within an equilateral triangle, is intended to alert you to the presence of uninsulated "dangerous voltage" within the product's enclosure that may be of sufficient magnitude to constitute a risk of electric shock to persons.



The exclamation point within an equilateral triangle is intended to alert you to the presence of important operating and maintenance (servicing) instructions in the literature accompanying the appliance.

IMPORTANT

Please record the serial number of this unit in the space below.

MODEL:

Serial No.:

The serial number is located on the rear of the unit. Retain this Owner's Manual in a safe place for future reference.

- 1 Read these instructions.
- 2 Keep these instructions.
- 3 Heed all warnings.
- 4 Follow all instructions.
- 5 Do not use this apparatus near water.
- 6 Clean only with dry cloth.
- 7 Do not block any ventilation openings. Install in accordance with the manufacturer's instructions.
- 8 Do not install near any heat sources such as radiators, heat registers, stoves, or other apparatus (including amplifiers) that produce heat.
- 9 Do not defeat the safety purpose of the polarized or grounding-type plug. A polarized plug has two blades with one wider than the other. A grounding type plug has two blades and a third grounding prong. The wide blade or the third prong are provided for your safety. If the provided plug does not fit into your outlet, consult an electrician for replacement of the obsolete outlet.
- 10 Protect the power cord from being walked on or pinched particularly at plugs, convenience receptacles, and the point where they exit from the apparatus.
- 11 Only use attachments/accessories specified by the manufacturer.
- 12 Use only with the cart, stand, tripod, bracket, or table specified by the manufacturer, or sold with the apparatus. When a cart is used, use caution when moving the cart/apparatus combination to avoid injury from tip-over.
- 13 Unplug this apparatus during lightning storms or when unused for long periods of time.
- 14 Refer all servicing to qualified service personnel. Servicing is required when the apparatus has been damaged in any way, such as power-supply cord or plug is damaged, liquid has been spilled or objects have fallen into the apparatus, the apparatus has been exposed to rain or moisture, does not operate normally, or has been dropped.



We Want You Listening For A Lifetime

Yamaha and the Electronic Industries Association's Consumer Electronics Group want you to get the most out of your equipment by playing it at a safe level. One that lets the sound come through loud and clear without annoying blaring or distortion – and, most importantly, without affecting your sensitive hearing. Since hearing damage from loud sounds is often undetectable until it is too late, Yamaha and the Electronic Industries Association's Consumer Electronics Group recommend you to avoid prolonged exposure from excessive volume levels.



FCC INFORMATION (for US customers)

1 IMPORTANT NOTICE: DO NOT MODIFY THIS UNIT!

This product, when installed as indicated in the instructions contained in this manual, meets FCC requirements. Modifications not expressly approved by Yamaha may void your authority, granted by the FCC, to use the product.

2 IMPORTANT: When connecting this product to accessories and/or another product use only high quality shielded cables. Cable/s supplied with this product **MUST** be used. Follow all installation instructions. Failure to follow instructions could void your FCC authorization to use this product in the USA.

3 NOTE: This product has been tested and found to comply with the requirements listed in FCC Regulations, Part 15 for Class "B" digital devices. Compliance with these requirements provides a reasonable level of assurance that your use of this product in a residential environment will not result in harmful interference with other electronic devices.

This equipment generates/uses radio frequencies and, if not installed and used according to the instructions found in the users manual, may cause interference harmful to the operation of other electronic devices.

Compliance with FCC regulations does not guarantee that interference will not occur in all installations. If this product is found to be the source of interference, which can be determined by turning the unit "OFF" and "ON", please try to eliminate the problem by using one of the following measures:

Relocate either this product or the device that is being affected by the interference.

Utilize power outlets that are on different branch (circuit breaker or fuse) circuits or install AC line filter/s.

In the case of radio or TV interference, relocate/reorient the antenna. If the antenna lead-in is 300 ohm ribbon lead, change the lead-in to coaxial type cable.

If these corrective measures do not produce satisfactory results, please contact the local retailer authorized to distribute this type of product. If you can not locate the appropriate retailer, please contact Yamaha Electronics Corp., USA 6660 Orangethorpe Ave., Buena Park, CA 90620.

The above statements apply **ONLY** to those products distributed by Yamaha Corporation of America or its subsidiaries.

CAUTION: READ THIS BEFORE OPERATING YOUR UNIT.

- 1 To assure the finest performance, please read this manual carefully. Keep it in a safe place for future reference.
- 2 Install this sound system in a well ventilated, cool, dry, clean place - away from direct sunlight, heat sources, vibration, dust, moisture, and/or cold. For proper ventilation, allow the following minimum clearances around this unit.
Top: 30 cm (11-3/4 in)
Rear: 20 cm (7-7/8 in)
Sides: 20 cm (7-7/8 in)
- 3 Locate this unit away from other electrical appliances, motors, or transformers to avoid humming sounds.
- 4 Do not expose this unit to sudden temperature changes from cold to hot, and do not locate this unit in an environment with high humidity (i.e. a room with a humidifier) to prevent condensation inside this unit, which may cause an electrical shock, fire, damage to this unit, and/or personal injury.
- 5 Avoid installing this unit where foreign object may fall onto this unit and/or this unit may be exposed to liquid dripping or splashing. On the top of this unit, do not place:
 - Other components, as they may cause damage and/or discoloration on the surface of this unit.
 - Burning objects (i.e. candles), as they may cause fire, damage to this unit, and/or personal injury.
 - Containers with liquid in them, as they may fall and liquid may cause electrical shock to the user and/or damage to this unit.
- 6 Do not cover this unit with a newspaper, tablecloth, curtain, etc. in order not to obstruct heat radiation. If the temperature inside this unit rises, it may cause fire, damage to this unit, and/or personal injury.
- 7 Do not plug in this unit to a wall outlet until all connections are complete.
- 8 Do not operate this unit upside-down. It may overheat, possibly causing damage.
- 9 Do not use force on switches, knobs and/or cords.
- 10 When disconnecting the power cable from the wall outlet, grasp the plug; do not pull the cable.
- 11 Do not clean this unit with chemical solvents; this might damage the finish. Use a clean, dry cloth.
- 12 Only voltage specified on this unit must be used. Using this unit with a higher voltage than specified is dangerous and may cause fire, damage to this unit, and/or personal injury. Yamaha will not be held responsible for any damage resulting from use of this unit with a voltage other than specified.
- 13 To prevent damage by lightning, keep the power cable and outdoor antennas disconnected from a wall outlet or this unit during a lightning storm.
- 14 Do not attempt to modify or fix this unit. Contact qualified Yamaha service personnel when any service is needed. The cabinet should never be opened for any reasons.
- 15 When not planning to use this unit for long periods of time (i.e. vacation), disconnect the AC power plug from the wall outlet.
- 16 Be sure to read the “TROUBLESHOOTING” section on common operating errors before concluding that this unit is faulty.
- 17 Before moving this unit, press ϕ to set this unit to the standby mode, and disconnect the AC power plug from the wall outlet.
- 18 Condensation will form when the surrounding temperature changes suddenly. Disconnect the power cable from the outlet, then leave this unit alone.
- 19 When using this unit for a long time, this unit may become warm. Turn the power off, then leave this unit alone for cooling.
- 20 Install this unit near the AC outlet and where the AC power plug can be reached easily.
- 21 The batteries shall not be exposed to excessive heat such as sunshine, fire or the like.
- 22 Excessive sound pressure from earphones and headphones can cause hearing loss.

As long as this unit is connected to the AC wall outlet, it is not disconnected from the AC power source even if you set this unit to standby mode by ϕ . In this state, this unit is designed to consume a very small quantity of power.

WARNING

TO REDUCE THE RISK OF FIRE OR ELECTRIC SHOCK, DO NOT EXPOSE THIS UNIT TO RAIN OR MOISTURE.

CAUTION

Danger of explosion if battery is incorrectly replaced.
Replace only with the same or equivalent type.



This label is required to be attached to a product of which the temperature of the top cover may be hot during operation.

CONTENTS

INTRODUCTION

USEFUL FEATURES	2
SUPPLIED ACCESSORIES	3
CONTROLS AND FUNCTIONS	4
Front panel	4
Front panel display	6
Rear panel	7
Remote control	8
Zone 2 remote control (R-S700 only)	10
Using the remote controls	11

PREPARATION

CONNECTIONS	12
Connecting speakers and source components	12
Connecting the FM and AM antennas	14
Using COUPLER jacks (R-S700 only)	15
Connecting power cable	15

BASIC OPERATION

PLAYING AND RECORDING	16
Playing a source	16
Adjusting the tonal quality	17
Recording a source	19
Using the sleep timer	19
FM/AM TUNING	20
Automatic tuning	20
Manual tuning	21
Automatic station preset (FM stations only)	22
Manual station preset	23
Recalling a preset station	24
Clearing a preset station	24
Clearing all preset stations	25
LISTENING TO SIRIUS Satellite Radio™	26
Connecting the SiriusConnect™ tuner	27
Activating SIRIUS Satellite Radio™ subscription	27
SIRIUS Satellite Radio™ operations	28
Registering and recalling SIRIUS Satellite Radio™ channels	30
Setting the Parental Lock	32
Displaying the SIRIUS Satellite Radio™ information	34
PLAYING BACK TUNES FROM YOUR iPhone/iPod/ Bluetooth™ COMPONENT	35
Using a Universal Dock for iPod	36
Using a Wireless System for iPod	37
Using a Bluetooth Wireless Audio Receiver	38

ADVANCED OPERATION

SETTING THE OPTION MENU FOR EACH INPUT SOURCE	40
Option menu items	40
ADVANCED SETUP	43
Changing the ADVANCED SETUP menu parameters	43
Switching the remote control ID	44
ZONE 2	45
Connecting Zone 2 components	45
Controlling Zone 2	46
REMOTE CONTROL FEATURES	47
Controlling this unit, a TV, or other components	47
Configuring the remote control	49

ADDITIONAL INFORMATION

TROUBLESHOOTING	50
SPECIFICATIONS	57

INTRODUCTION

PREPARATION

BASIC
OPERATION

ADVANCED
OPERATION

ADDITIONAL
INFORMATION

USEFUL FEATURES

This unit allows you to:

Improve sound quality by using the CD Direct Amp*1 and Pure Direct functions	➔ p. 17
Play back music from your iPhone/iPod*2 or Bluetooth component*2	➔ p. 35
Play back video content from your iPhone/iPod*1 *2	➔ p. 36
Listen to SIRIUS Satellite Radio channels*3	➔ p. 26
Listen to FM and AM radio stations	➔ p. 20
Boost bass sounds by connecting a subwoofer	➔ p. 12
Connect an external device*1 such as a graphic equalizer or a surround-sound processor	➔ p. 15
Use this unit's remote control to operate other components such as a CD player, BD/DVD player or TV	➔ p. 47
Save power by using the automatic power down function	➔ p. 43
Use this unit to listen to another input source in two different rooms	➔ p. 45

*1 R-S700 only

*2 Optional Yamaha product required

*3 Optional SiriusConnect tuner required



SIRIUS, XM and all related marks and logos are trademarks of Sirius XM Radio Inc. and its subsidiaries. All rights reserved. **Service not available in Alaska and Hawaii.**

iPhone, iPod

iPhone, iPod, iPod classic, iPod nano and iPod touch are trademarks of Apple Inc., registered in the U.S. and other countries.

Bluetooth™

Bluetooth is a registered trademark of the Bluetooth SIG and is used by Yamaha in accordance with a license agreement.

-  indicates a tip for your operation.
- This manual is the owner's manual for both the R-S700 and the R-S500. Model names are given where the details of functions are unique to each model. Generally, illustrations of the R-S700 are used for explanations.
- Some operations can be performed by using either the buttons on the front panel of this unit or those on the remote controls. In case the button names differ between this unit and the remote controls, the names of the buttons on the remote controls are given in parentheses.
- In case the buttons on the remote control and the Zone 2 remote control have certain functions in common, the illustrations of the buttons on the remote control are used for explanation throughout the manual.
- This manual is printed prior to production. Design and specifications are subject to change in part as a result of improvements, etc. In case of differences between the manual and the product, the product has priority.

SUPPLIED ACCESSORIES

Please check that you received all of the following parts.

Remote control

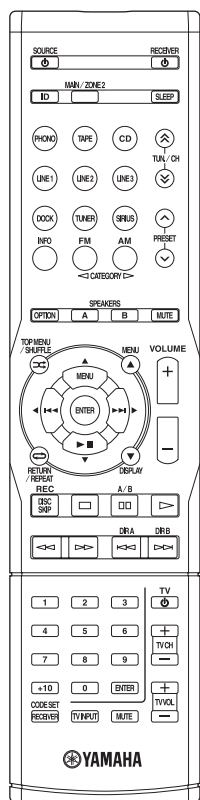

Zone 2 remote control (R-S700 only)

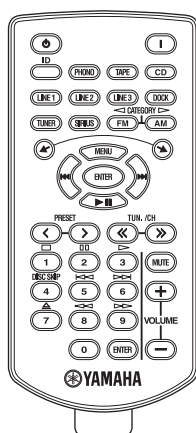

Power cable (R-S700 only)

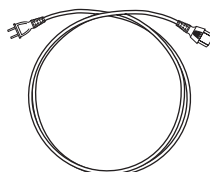

AM loop antenna



Indoor FM antenna

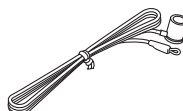

Batteries (x2) (AAA, R03, UM-4)

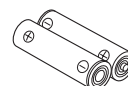

■ Notes on remote controls and batteries

- Do not spill water or other liquids on the remote control.
- Do not drop the remote control.
- Do not leave or store the remote control in the following conditions:
 - places of high humidity, such as near a bath
 - places of high temperatures, such as near a heater or stove
 - places of extremely low temperatures
 - dusty places
- Use AAA, R03, UM-4 batteries for the remote control.
- Use a CR2025 battery for the Zone 2 remote control (R-S700 only).
- Insert batteries according to the polarity markings (+ and -).
- Change all batteries if you notice the operation range of the remote control narrows.
- If the batteries run out, immediately remove them from the remote control to prevent an explosion or acid leak.
- If you find leaking batteries, discard the batteries immediately, taking care not to touch the leaked material. If the leaked material comes into contact with your skin or gets into your eyes or mouth, rinse it away immediately and consult a doctor. Clean the battery compartment thoroughly before installing new batteries.
- Do not use old batteries together with new ones. This may shorten the life of the new batteries or cause old batteries to leak.
- Do not use different types of batteries (such as alkaline and manganese batteries) together. Batteries that look the same may have a different specification.
- Before inserting new batteries, wipe the battery compartment clean.
- Dispose of batteries according to your regional regulations.

CONTROLS AND FUNCTIONS

Front panel

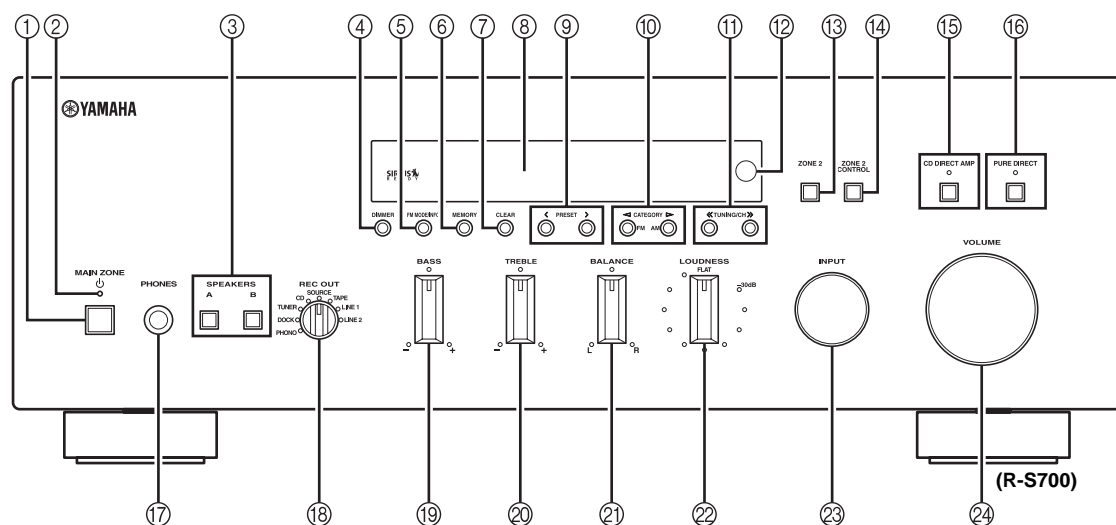

ZONE indicates buttons and controls that can also be used to control Zone 2. For more information about Zone 2, see pages 45 and 46.

① MAIN ZONE

Turns on this unit's Main Zone unit or sets the Main Zone to standby mode (see page 16).

Note

In standby mode, this unit consumes a small amount of power to receive infrared signals from the remote control.

② MAIN ZONE indicator

Lights up as follows:
 Brightly lit: Power is on
 Dimly lit: Standby mode

Note

The MAIN ZONE indicator is brightly lit while an iPhone/iPod is charging.

③ SPEAKERS A/B

Turns on or off the speaker set connected to the SPEAKERS A and/or SPEAKERS B terminals on the rear panel each time the corresponding button is pressed (see page 16).

④ DIMMER

Changes the brightness level of the front panel display. Choose brightness from 3 levels by pressing this button repeatedly.



This setting is retained even if you turn off this unit.

⑤ FM MODE/INFO

Changes the FM radio wave reception mode (stereo or monaural) when TUNER is selected as the input source (see page 21).

Changes the SIRIUS Satellite Radio information displayed on the front panel display when SIRIUS is selected as the input source (see page 34).

Changes the playback information displayed about the song playing on the iPhone/iPod when DOCK is selected as the input source (see page 36).

Note

Playback information can only be displayed for an iPhone/iPod that is connected using a Universal Dock for iPod.

⑥ MEMORY

Stores the current FM/AM station as a preset when TUNER is selected as the input source (see page 23).
 Stores the current SIRIUS channel as a preset when SIRIUS is selected as the input source (see page 30).

⑦ CLEAR

Clears the current FM/AM preset station when TUNER is selected as the input source (see page 24).
 Clears the current SIRIUS preset channel when SIRIUS is selected as the input source (see page 32).

⑧ Front panel display

Shows information about the operational status of this unit.

⑨ PRESET </> ZONE

Selects a preset FM/AM station when TUNER is selected as the input source (see page 24).

Selects a preset SIRIUS channel when SIRIUS is selected as the input source (see page 31).

⑩ FM/CATEGORY ◀, AM/CATEGORY ▶ ZONE

Sets the FM/AM tuner band to FM or AM when TUNER is selected as the input source (see page 20).

Selects a channel category when SIRIUS is selected as the input source (see page 29).

⑪ TUNING/CH <</>> ZONE

Selects the tuning frequency when TUNER is selected as the input source (see page 20).

Searches for a SIRIUS channel when SIRIUS is selected as the input source (see page 29).

⑫ Remote control sensor

Receives infrared signals from the remote control.

Note

Switch the remote control ID between ID1 and ID2 when using multiple Yamaha receivers or amplifiers (see page 44).

⑬ ZONE 2

Turns on Zone 2 or sets ZONE 2 to standby mode. When Zone 2 is turned on, signals are output to the ZONE 2 OUT jacks (see page 45).

⑭ ZONE 2 CONTROL

Allows buttons and controls on the front panel to be used to control Zone 2. For more information about controlling Zone 2, see page 46.

⑮ CD DIRECT AMP and indicator (R-S700 only)

Allows you to listen to a CD source in the purest possible sound (see page 17). The indicator lights up and the front panel display turns off when this function is turned on.

Notes

- If both the CD DIRECT AMP and the PURE DIRECT are turned on, only the CD DIRECT AMP will function.
- Zone 2 cannot be used while this function is turned on.

⑯ PURE DIRECT and indicator

Allows you to listen to a source in the purest possible sound (see page 17). The indicator above it lights up and the front panel display turns off when this function is turned on.

Note

Zone 2 cannot be used while this function is turned on.

⑰ PHONES jack

Outputs audio to your headphones for private listening.

Note

Press SPEAKER A/B so that the SP A/B indicators turn off before you connect your headphones to the PHONES jack.

⑱ REC OUT selector

Selects a source for recording to a CD recorder or to a tape deck independently of the INPUT selector setting, allowing you to record the selected source while listening to another source (see page 19).

⑲ BASS control

Increases or decreases the low frequency response. The center position produces a flat response (see page 18).

⑳ TREBLE control

Increases or decreases the high frequency response. The center position produces a flat response (see page 18).

㉑ BALANCE control

Adjusts the sound output balance of the left and right speakers to compensate for sound imbalances caused by speaker locations or listening room conditions (see page 18).

㉒ LOUDNESS control

Retains a full tonal range at any volume level to compensate for the human ears' loss of sensitivity to high and low-frequency ranges at a low volume level (see page 18).

㉓ INPUT selector ZONE

Selects the input source you want to listen to.

㉔ VOLUME control (ZONE R-S700 only)

Increases or decreases the sound output level.

Note

This does not affect the output level of the REC jacks.

Front panel display

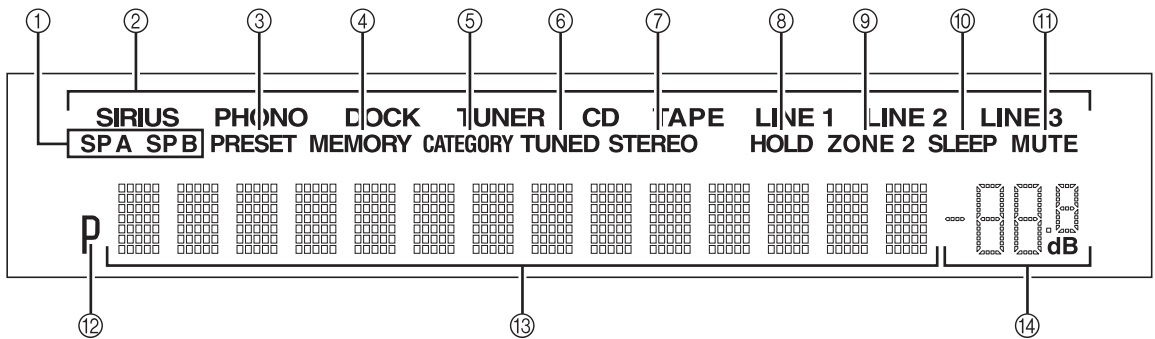

① **SP (SPEAKERS) A/B indicators**

Light up according to the set of speakers selected. Both indicators light up when both sets of speakers are selected.

② **Input source indicators**

Light up brightly to indicate the input source that is currently selected.

③ **PRESET indicator**

Lights up when you recall a preset radio station or SIRIUS channel. Blinks while the automatic station preset feature is scanning for FM stations to register as presets.

④ **MEMORY indicator**

Lights up or blinks when an FM/AM station or SIRIUS channel is being stored as a preset.

⑤ **CATEGORY indicator**

Lights up when searching for a SIRIUS channel by category.

⑥ **TUNED indicator**

Lights up when this unit is tuned in to an FM or AM station.

⑦ **STEREO indicator**

Lights up when this unit is receiving a strong signal for an FM stereo broadcast.

⑧ **HOLD indicator**

Blinks when the hold function is used to display the artist name, song title, etc. while listening to a SIRIUS channel.

⑨ **ZONE 2 indicator**

Lights up when Zone 2 is turned on.

⑩ **SLEEP indicator**

Lights up when the sleep timer is turned on.

⑪ **MUTE indicator**

Blinks while the MUTE function is turned on.

⑫ **P indicator**

Lights up when a preset number is selected. Blinks while you are registering a preset radio station or SIRIUS channel.

⑬ **Multi-information display**

Shows information when adjusting or changing settings.

⑭ **Volume indicator**

Displays the current volume level.

Rear panel

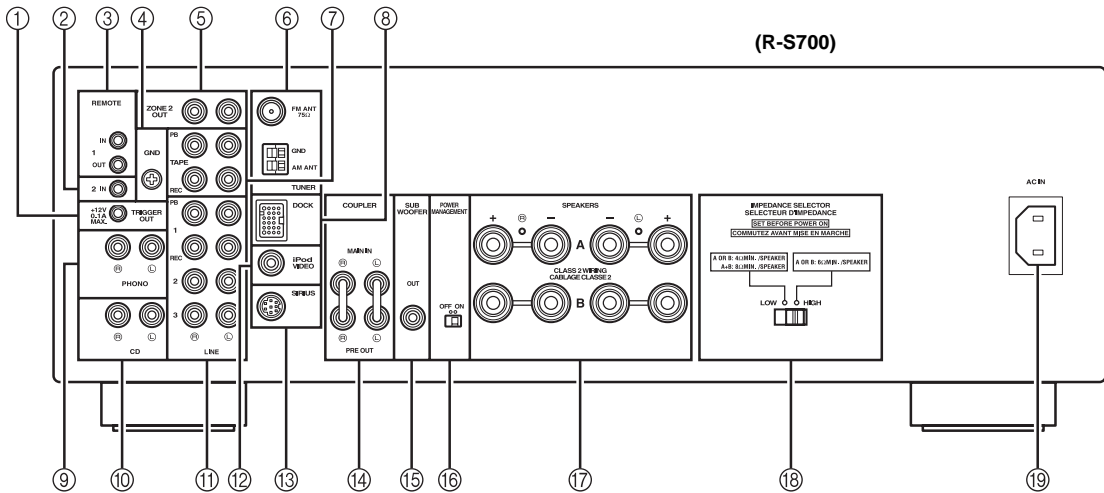

① TRIGGER OUT jack (R-S700 only)

When this unit is turned on or when a certain input source is selected, this unit can send a 12 V/100 mA direct electric current via the TRIGGER OUT jack that can be used to control an external component. The current is sent according to the “Trigger out” setting in the Option menu (see page 40).

Note

Do not connect a component that requires more than 100 mA of electric current, otherwise the component may not perform consistently or properly due to insufficient power.

② REMOTE 2 IN jack (R-S700 only)

Used to receive remote control signals (see page 45).

③ REMOTE 1 IN/OUT jacks

Used to send and receive remote control signals (see page 45).

④ GND terminal

Used to connect a turntable (see page 12).

⑤ ZONE 2 OUT jacks

Used to connect a Zone 2 component (see page 45).

⑥ Antenna terminals

Used to connect FM and AM antennas (see page 14).

⑦ TAPE jacks

Used to connect a tape deck (see page 12).

⑧ DOCK jack

Used to connect an optional Yamaha Universal Dock for iPod (such as the YDS-12), Wireless System for iPod (YID-W10), or Bluetooth Wireless Audio Receiver (YBA-10) (see page 35).

⑨ PHONO jacks

Used to connect a turntable (see page 12).

⑩ CD jacks

Used to connect a CD player (see page 12).

⑪ LINE 1-3 jacks

Used to connect audio components (see page 12).

⑫ iPod VIDEO output jack (R-S700 only)

Used to send iPhone/iPod video content to a video monitor, such as a TV (see page 35).

Note

Video content output is possible only when an iPhone/iPod is connected this unit using a Universal Dock for iPod (such as the YDS-12).

⑬ SIRIUS jack

Used to connect SiriusConnect tuner (sold separately) (see page 27).

⑭ COUPLER jacks (R-S700 only)

Used to connect an external unit (see page 15).

⑮ SUBWOOFER OUT jack

Used to connect a subwoofer with built-in amplifier (see page 12).

The SUBWOOFER OUT jack attenuates signals over 90 Hz.

⑯ POWER MANAGEMENT switch

Used to enable or disable the automatic power down function. When this function is enabled, this unit's Main zone and Zone 2 automatically enters standby mode if this unit is not operated for a certain amount of time (3 settings are available; see page 43).

⑰ SPEAKERS terminals

Used to connect speakers (see page 12).

⑱ IMPEDANCE SELECTOR switch

Used to select the impedance setting (see page 13).

⑲ AC IN (R-S700 only)

Used to plug in the supplied power cable (see page 15).

Remote control

This section describes the function of each button on the remote control used to control this unit or other components made by Yamaha or other manufacturers.



ZONE indicates buttons that can also be used to control Zone 2. For more information about Zone 2, see pages 45 and 46.

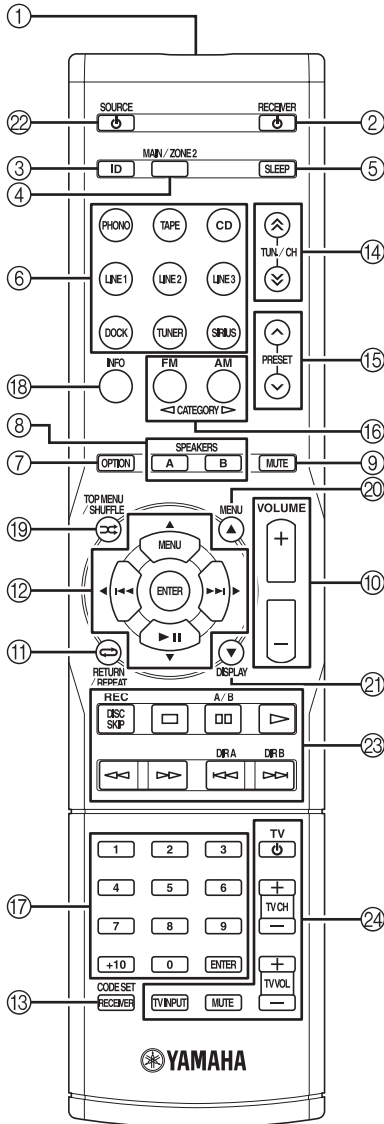

Common controls

The following buttons can be used no matter which input source is selected.

① Infrared signal transmitter

Sends infrared signals.

② RECEIVER **ZONE**

Turns this unit on, or sets it to standby mode.

③ ID

Changes the remote control ID (see page 44).

④ MAIN/ZONE 2

Switches the zone to be operated by the remote control between the Main Zone and Zone 2 (see page 46).

⑤ SLEEP

Sets the sleep timer (see page 19).

⑥ Input selector buttons **ZONE**

Selects the input source and changes the control area (see page 47).

⑦ OPTION

Turns the OPTION menu on and off (see page 40).

⑧ SPEAKERS A/B

Turns on and off the set of speakers connected to the SPEAKERS A and/or SPEAKERS B terminals on the rear panel of this unit when the corresponding button is pressed.

⑨ MUTE **ZONE**

Mutes the sound output. Press again to restore the sound output to the previous volume level.

⑩ VOLUME +/- (**ZONE R-S700 only**)

Increases or decreases the sound output level.

Note

This does not affect the output level of the REC jacks.

⑪ RETURN

Returns to the previous menu or ends the menu display when using the Option menu (see page 40).

⑫ Δ / ▽ / ◀ / ▶ / ENTER

Selects and confirms items in the Option menu (see page 40).

⑬ CODE SET/RECEIVER

Used to program the remote control so that it can control your other external components (see page 49). After using the remote control to control one of your components, this button is used to switch the remote control to receiver mode so that remote control commands will be sent to this unit (see page 48).

■ SIRIUS and FM/AM controls

The following buttons can be used when SIRIUS or TUNER is selected as the input source.

⑭ TUN./CH / ZONE

Selects the tuning frequency when TUNER is selected as the input source (see page 20).

Searches for a SIRIUS channel when SIRIUS is selected as the input source (see page 29).

⑮ PRESET / ZONE

Selects a preset FM/AM station when TUNER is selected as the input source (see page 24).

Select a preset SIRIUS channel when SIRIUS is selected as the input source (see page 31).

⑯ FM/CATEGORY , AM/CATEGORY ZONE

Sets the FM/AM tuner band to FM or AM when TUNER is selected as the input source (see page 20).

Selects a channel category when SIRIUS is selected as the input source (see page 29).

⑰ Numeric buttons, ENTER ZONE

Specifies the frequency or the preset number of the FM/AM station when TUNER is selected as the input source (see page 21).

Specifies the channel number or preset number of the SIRIUS channel when SIRIUS is selected as the input source (see page 30).

⑱ INFO

Changes the SIRIUS Satellite Radio information displayed on the front panel display when SIRIUS is selected as the input source (see page 34).

■ iPod controls

The following buttons can be used when DOCK is selected as the input source for listening to an iPhone/iPod. For more information, see page 35.

⑪ REPEAT

⑫ MENU / / / ENTER ZONE

⑱ INFO

⑲ SHUFFLE

⑳ ZONE

㉑ ZONE

■ External component controls

The following buttons can be used to control external audio/video components when CD, TAPE, PHONO, LINE1, LINE2, or LINE3 is selected as the input source. For more information, see page 47.

⑪ RETURN

⑫ / / / / ENTER

⑰ Numeric buttons, ENTER

⑲ TOP MENU

⑳ MENU

㉑ DISPLAY

㉒ SOURCE

㉓ External component control buttons

㉔ TV control buttons

Zone 2 remote control (R-S700 only)

This section describes the function of each button on the Zone 2 remote control, which is used to control Zone 2.

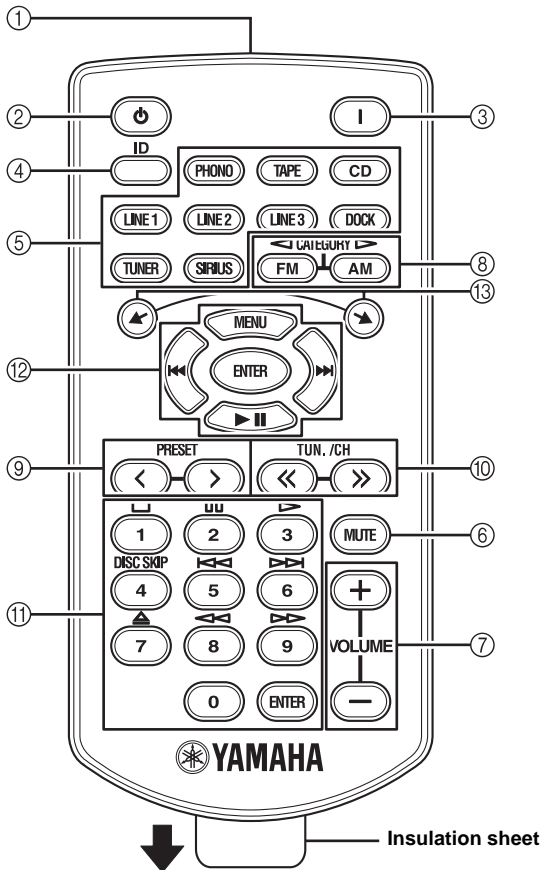

Note

The Zone 2 remote control comes with a battery already installed. Before using the Zone 2 remote control for the very first time, pull out the insulation sheet, as shown.

Common controls for Zone 2

The following buttons can be used no matter which input source is selected for Zone 2.

① Infrared signal transmitter

Sends infrared signals.

② **⏻ (Zone 2 standby)**

Sets Zone 2 to standby mode.

③ **I (Zone 2 on)**

Turns on Zone 2.

④ **ID**

Changes the Zone 2 remote control ID (see page 44).

⑤ **Zone 2 input selector buttons**

Selects the desired input source for Zone 2.

⑥ **MUTE**

Mutes the sound output to Zone 2. Press again to restore the sound output to the previous volume level.

⑦ **VOLUME +/-**

Increases or decreases the sound output level of Zone 2.

■ SIRIUS and FM/AM controls

The following buttons can be used when SIRIUS or TUNER is selected as the input source for Zone 2.

⑧ **FM/CATEGORY <|, AM/CATEGORY >|**

Sets the FM/AM tuner band to FM or AM when TUNER is selected as the input source (see page 20).

Selects a channel category when SIRIUS is selected as the input source (see page 29).

⑨ **PRESET <| / >|**

Selects a preset FM/AM station when TUNER is selected as the input source (see page 24).

Selects a preset SIRIUS channel when SIRIUS is selected as the input source (see page 31).

⑩ **TUN./CH <<| / >>|**

Selects the tuning frequency when TUNER is selected as the input source (see page 20).

Searches for a SIRIUS channel when SIRIUS is selected as the input source (see page 29).

⑪ **Numeric buttons, ENTER**

Specifies the frequency or the preset number of the FM/AM station when TUNER is selected as the input source (see page 21).

Specifies the channel number or preset number of the SIRIUS channel when SIRIUS is selected as the input source (see page 30).

■ iPod controls

The following buttons can be used when DOCK is selected as the input source for Zone 2, for listening to an iPhone/iPod. For more information, see page 35.



⑫ **MENU/▷□□ / ◀◀ / ▷▷ / ENTER**





⑬ **↶ / ↷**

■ Yamaha CD player controls

The following buttons can be used to control a Yamaha CD player when CD is selected as the input source for Zone 2.

⑪ Yamaha CD player control buttons

-  Stops playback
-  Pauses playback
-  Starts playback
- DISC SKIP Skips to the next disc in a CD changer

-  Skips backward
-  Skips forward
-  Ejects the disc
-  Rewinds playback
-  Fast-forwards playback

Note

Not all Yamaha CD players can be controlled by the Zone 2 remote control.

Using the remote controls

■ Installing batteries

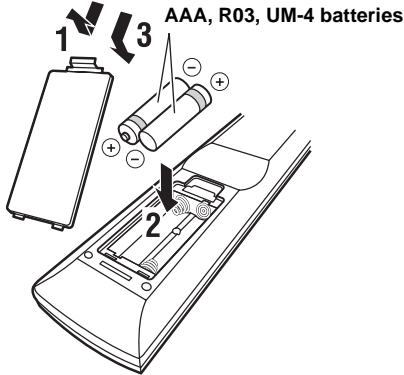

■ Replacing the battery in the Zone 2 remote control

Change the battery when the operation range of the Zone 2 remote control decreases.

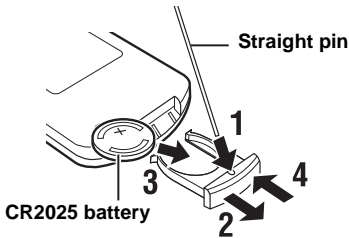

■ Operation range

The remote controls transmit a directional infrared beam. Be sure to aim the remote controls directly at the remote control sensor on the front panel of this unit or on the infrared signal receiver in Zone 2 during operation.

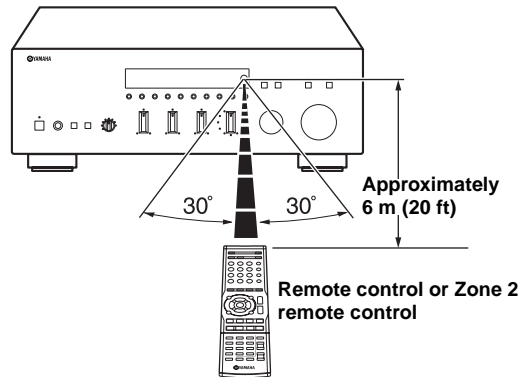

CONNECTIONS

Connecting speakers and source components

CAUTION

- Do not connect this unit or other components to the main power until all connections between components are complete.
- All connections must be correct: L (left) to L, R (right) to R, “+” to “+” and “-” to “-”. If the connections are faulty, no sound will be heard from the speakers, and if the polarity of the speaker connections is incorrect, the sound will be unnatural and lack bass. Refer to the owner’s manual for each of your components.
- Use RCA cables for audio components (except for speaker connections and DOCK jack connections).
- The IMPEDANCE SELECTOR must be set to the appropriate position before connecting speakers. See page 13 for details.
- Do not let bare speaker wires touch each other or any metal part of this unit. This could damage this unit and/or the speakers.

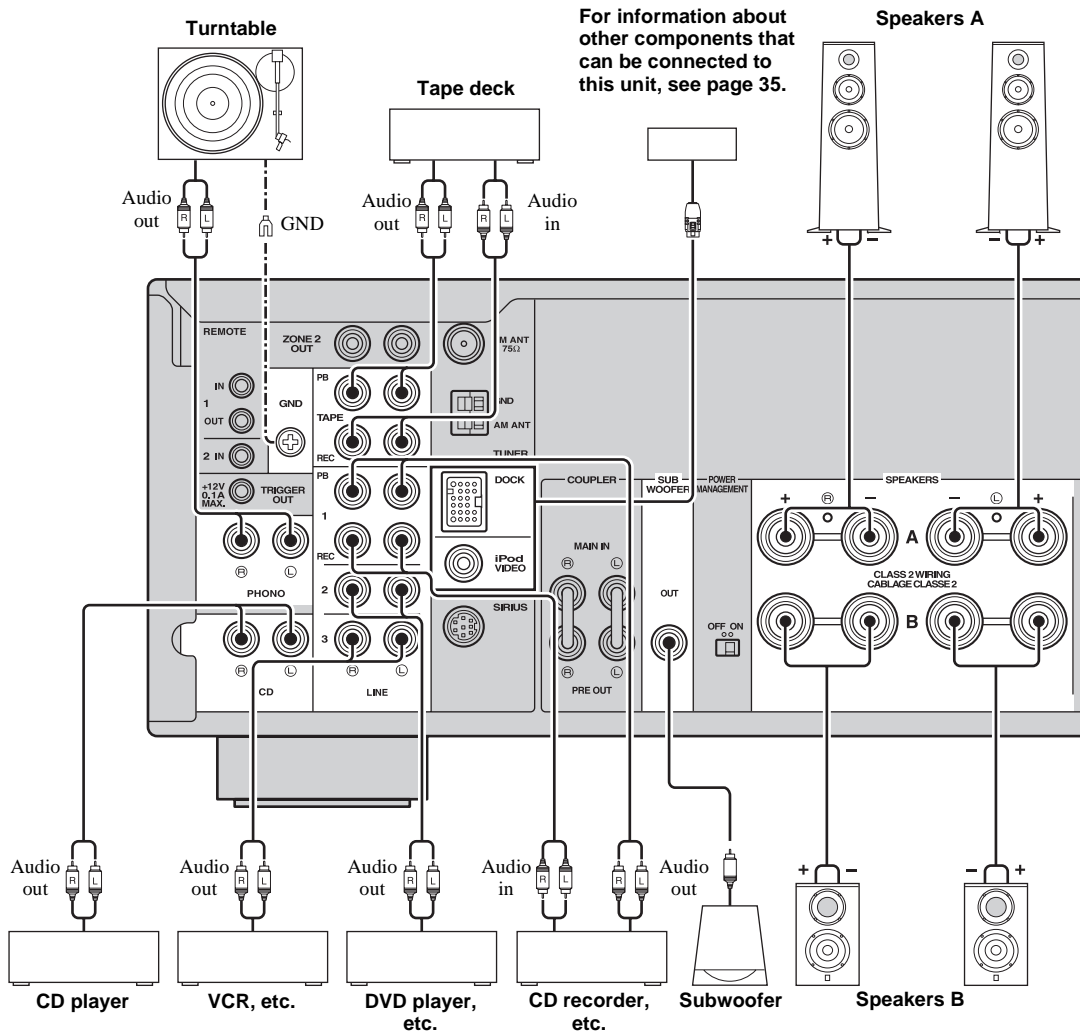

For information about other components that can be connected to this unit, see page 35.



- The PHONO jacks are designed for connecting a turntable with an MM cartridge.
- Connect your turntable to the GND terminal to reduce noise in the signal. However, for some turntables, you may hear less noise without the GND connection.

■ IMPEDANCE SELECTOR switch

CAUTION

Do not change the IMPEDANCE SELECTOR switch while the power of this unit is turned on, as doing so may damage the unit.

If the unit fails to turn on, the IMPEDANCE SELECTOR switch may not be fully slid to either position. If this is the case, remove the power cable and slide the switch all the way to either position.

Select the switch position (LOW or HIGH) according to the impedance of the speakers in your system.

Switch position	Impedance level
HIGH	<ul style="list-style-type: none"> If you use one set (A or B), the impedance of each speaker must be 6 Ω or higher (R-S700) or 8 Ω or higher (R-S500). If you make bi-wire connections, the impedance of each speaker must be 6 Ω or higher (R-S700) or 8 Ω or higher (R-S500). See page 13 for Bi-wire connection.
LOW	<ul style="list-style-type: none"> If you use one set (A or B), the impedance of each speaker must be 4 Ω or higher. If you use two sets (A and B) simultaneously, the impedance of each speaker must be 8 Ω or higher. If you make bi-wire connections, the impedance of each speaker must be 4 Ω or higher. See page 13 for Bi-wire connection.

■ Connecting speaker cables

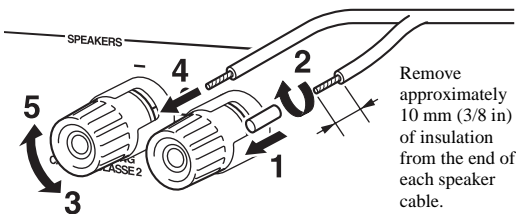

Note

When inserting speaker cables into the speaker terminals, insert only the bare speaker wire. If insulated cable is inserted, the connection may be poor and sound may not be heard.

■ Connecting via banana plug

Tighten the knob and then insert the banana plug into the end of the corresponding terminal.

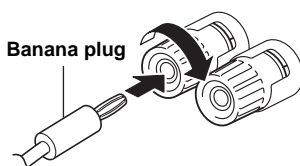

■ Bi-wire connection

Bi-wire connection separates the woofer from the combined midrange and tweeter section. A bi-wire compatible speaker has four binding post terminals. These two sets of terminals allow the speaker to be split into two independent sections. With these connections, the mid and high frequency drivers are connected to one set of terminals and the low frequency driver to another set of terminals.

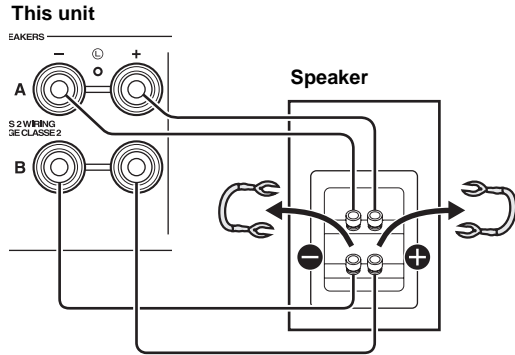

Connect the other speaker to the other set of terminals in the same way.

CAUTION

When making bi-wire connections, set the IMPEDANCE SELECTOR switch to HIGH or LOW depending on the impedance of your speakers:

- 6 Ω or higher: HIGH (R-S700)
- 8 Ω or higher: HIGH (R-S500)
- 4 Ω or higher: LOW

See page 13 for more information about the IMPEDANCE SELECTOR switch.

Note

When making bi-wire connections, remove the shorting bridges or cables on the speaker.



To use the bi-wire connections, press SPEAKERS A and SPEAKERS B on the front panel or on the remote control so that both SP A and B light up on the front panel display.

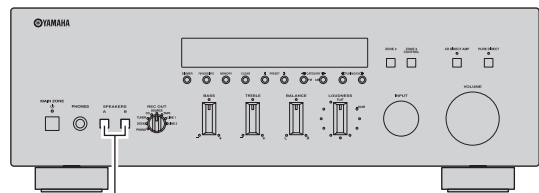

SPEAKERS A/B

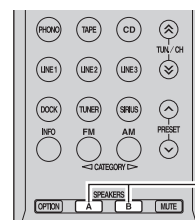

SPEAKERS A/B

Connecting the FM and AM antennas

Indoor antennas for receiving FM and AM broadcasts are included with this unit. In general, these antennas should provide sufficient signal strength. Connect each antenna correctly to the designated terminals.

Note

If you experience poor reception quality, install an outdoor antenna. Consult the nearest authorized Yamaha dealer or service center about outdoor antennas.

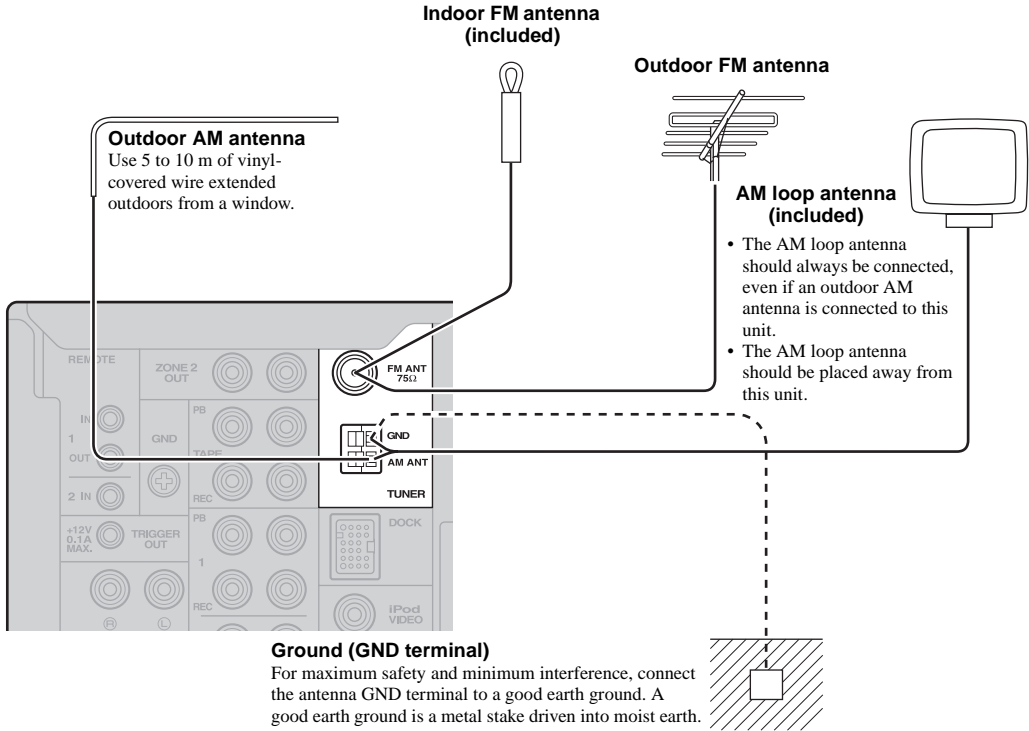

■ Assembling the supplied AM loop antenna

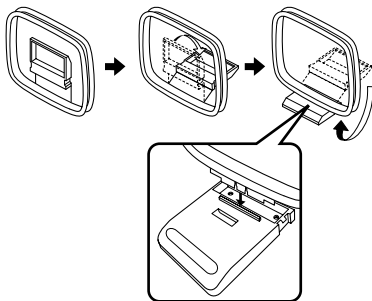

■ Connecting the wire of the AM loop antenna

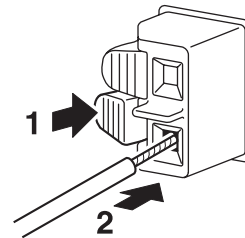

Using COUPLER jacks (R-S700 only)

Removing the jumper pins from the PRE OUT/MAIN IN jacks enables this unit to operate separately as a control amplifier or a power amplifier. These jacks are used to connect a signal-processing system such as a graphic equalizer or a surround-sound processor to this unit. If an external unit is connected to these jacks, the VOLUME control of this unit can be used to adjust the overall sound output level.

To connect an external unit, first remove the jumper pins from the PRE OUT/MAIN IN jacks and then connect the input jacks of that external unit to the PRE OUT jacks or its output jacks to the MAIN IN jacks. For details, refer to the owner's manual included with the external unit to be connected.

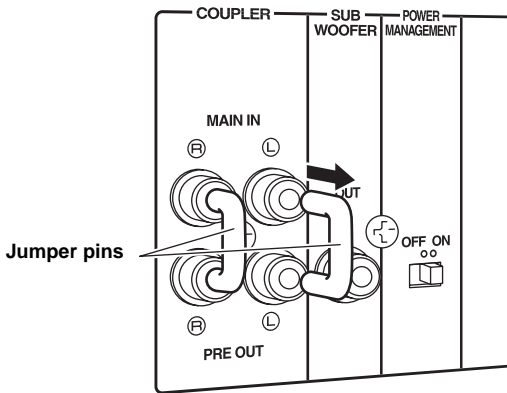

Notes

- If you do not use the COUPLER jacks, never remove the jumper pins from these jacks. If removed, no sound will be output from this unit.
- Before installing or removing the jumper pins, be sure to disconnect the power cable of the unit. Leaving the power cable connected could cause noise to be emitted from the speakers or damage the unit.
- When you use this unit as a power amplifier, connect the output jacks of the external control amplifier, etc. to the MAIN IN jacks of this unit. In this case, the controls of this unit will not function except the PHONES jack and the SPEAKERS A/B buttons. Use the controls on the external control amplifier to make volume adjustments, etc.

Connecting power cable

Plug the power cable into the AC IN on the rear panel of this unit (R-S700 only).

Plug the power cable into the AC wall outlet after all other connections are complete.

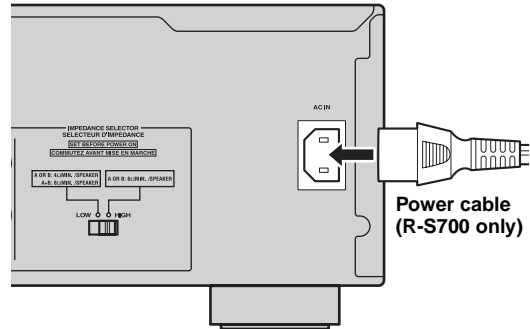

PLAYING AND RECORDING



CAUTION

Extreme caution should be exercised when you play back CDs encoded in DTS.

If you play back a CD encoded in DTS on a CD player that does not support DTS, only noise will be heard, and this noise may damage your speakers. Check whether your CD player supports CDs encoded in DTS. Also, check the sound output level of your CD player before you play back a CD encoded in DTS.

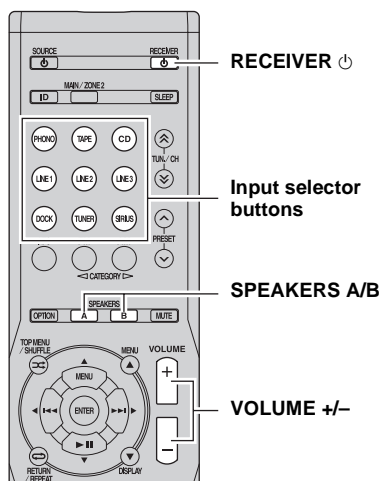
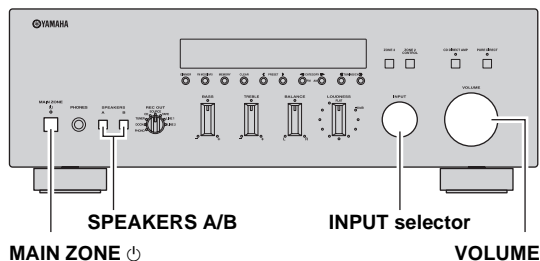
Playing a source



1 Press **MAIN ZONE**  on the front panel (or **RECEIVER**  on the remote control) to turn on this unit.

2 Rotate the **INPUT selector** on the front panel (or press one of the input selector buttons on the remote control) to select the input source you want to listen to.

3 Press **SPEAKERS A** and/or **SPEAKERS B** on the front panel or on the remote control to select speakers A and/or speakers B.

When speaker set A or speaker set B are turned on, SP A or SP B is displayed on the front panel display accordingly (see page 6).

Notes



- When one set of speakers is connected using bi-wire connections, or when using two sets of speakers simultaneously (A and B), make sure SP A and SP B are displayed on the front panel display.
- When listening with headphones, turn off the speakers.

4 Play the source.

5 Rotate the **VOLUME** control on the front panel (or press **VOLUME +/-** on the remote control) to adjust the sound output level.



You can adjust the tonal quality by using the **BASS**, **TREBLE**, **BALANCE** and **LOUDNESS** controls, the **CD DIRECT AMP** switch (R-S700 only), or the **PURE DIRECT** switch on the front panel (see page 17).

6 Press **MAIN ZONE**  on the front panel again (or **RECEIVER**  on the remote control) to finish using this unit and set it to standby mode.

Adjusting the tonal quality

■ Using the CD DIRECT AMP switch (R-S700 only)

CD Direct Amp feature

Generates a normal phase and reverse phase signal for both the left and right channels from the input signal and uses the four electronic volumes to send a balanced signal to the amplifying circuit. This feature provides clearer sound as a result of:

- improved signal-to-noise ratio
- external noise canceling
- reduced distortion

Routes input signals from your CD player directly to the specially built-in amplifier for the CD player. As a result, the input signals bypass the INPUT selector and the BASS, TREBLE, BALANCE and LOUDNESS controls and then sent to the power amplifier, thus eliminating any alterations to the CD signals and creating the purest possible sound. The CD DIRECT AMP indicator lights up and the front panel display turns off after a few seconds.

CD DIRECT AMP switch

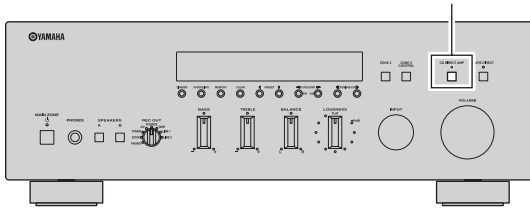

Notes

- If both the CD DIRECT AMP and the PURE DIRECT switches are turned on, only the CD DIRECT AMP switch will function.
- Zone 2 cannot be used while the CD DIRECT AMP feature is turned on.
- The INPUT selector and the BASS, TREBLE, BALANCE, and LOUDNESS controls do not function while the CD DIRECT AMP feature is turned on.
- A CD player must be connected to the CD jacks in order to use the CD DIRECT AMP feature.
- This setting is retained even if you turn off this unit.

■ Using the PURE DIRECT switch

Routes input signals from your audio sources so that the input signals bypass the BASS, TREBLE, BALANCE and LOUDNESS controls, thus eliminating any alterations to the audio signals and creating the purest possible sound. The PURE DIRECT indicator lights up and the front panel display turns off after a few seconds.

PURE DIRECT switch

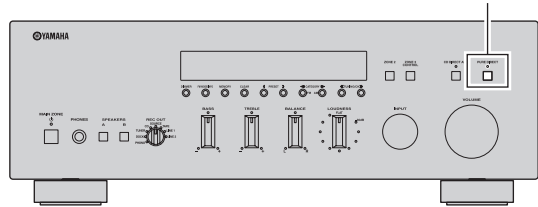

Notes

- Zone 2 cannot be used while the PURE DIRECT feature is turned on.
- The BASS, TREBLE, BALANCE, and LOUDNESS controls do not function while the PURE DIRECT feature is turned on.
- This setting is retained even if you turn off this unit.

■ Adjusting the BASS and TREBLE controls

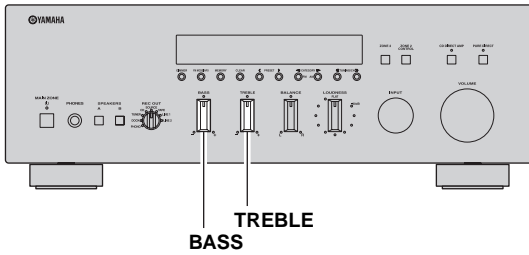

The BASS and TREBLE controls adjust high and low frequency response. The center position produces a flat response.

BASS

When you feel there is not enough bass (low frequency sound), rotate clockwise to boost. When you feel there is too much bass, rotate counterclockwise to suppress. Control range: -10 dB to +10 dB (20 Hz)

TREBLE

When you feel there is not enough treble (high frequency sound), rotate clockwise to boost. When you feel there is too much treble, rotate counterclockwise to suppress. Control range: -10 dB to +10 dB (20 kHz)



■ Adjusting the BALANCE control

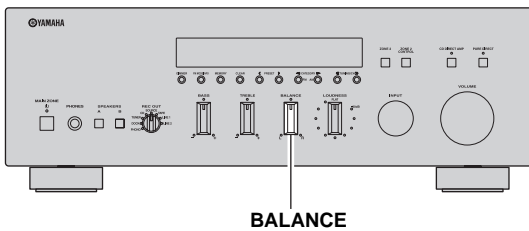

The BALANCE control adjusts the sound output balance of the left and right speakers to compensate for sound imbalance caused by speaker locations or listening room conditions.

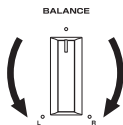

■ Adjusting the LOUDNESS control

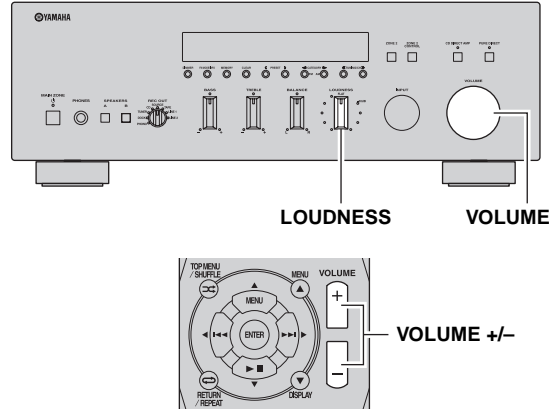

Retain a full tonal range at any volume level, thus compensating for the human ears' loss of sensitivity to high and low-frequency ranges at low volume.

CAUTION

If the CD DIRECT AMP switch (R-S700 only) or the PURE DIRECT switch is turned on with the LOUDNESS control set at a certain level, the input signals bypass the LOUDNESS control, resulting in a sudden increase in the sound output level. To prevent your ears or the speakers from being damaged, be sure to press the CD DIRECT AMP switch (R-S700 only) or the PURE DIRECT switch after lowering the sound output level or after checking that the LOUDNESS control is properly set.

- 1 Set the LOUDNESS control to the FLAT position.

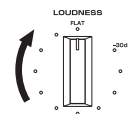

- 2 Rotate the VOLUME control on the front panel (or press VOLUME +/- on the remote control) to set the sound output level to the loudest listening level that you would listen to.

- 3 Rotate the LOUDNESS control until the desired volume is obtained.

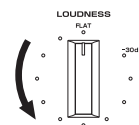

After setting the LOUDNESS control, enjoy listening to music at your preferred volume level. If the effect of the LOUDNESS control setting is too strong or weak, readjust the LOUDNESS control.

Recording a source

Notes

- Audio signals are not output to the TAPE REC or LINE 1 REC output jacks when TAPE or LINE 1 is selected with the REC OUT selector.
- Audio signals are output to both the TAPE REC and the LINE 1 REC output jacks if when PHONO, DOCK, TUNER, CD, SOURCE or LINE 2 is selected with the REC OUT selector.
- This unit must be turned on in order to record.
- The VOLUME, BASS, TREBLE, BALANCE and LOUDNESS controls and the CD DIRECT AMP switch (R-S700 only) and the PURE DIRECT switch have no effect on the source being recorded.
- Check the copyright laws in your country before recording from records, CDs, radio, etc. Recording copyright-protected material may infringe on copyright laws.

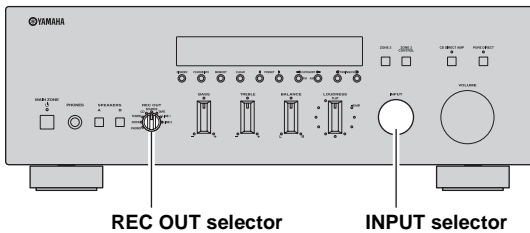

- 1 Rotate the REC OUT selector on the front panel to select the source you want to record.

When SOURCE is selected, the current input source is output.

Note

SIRIUS Satellite Radio broadcasts cannot be recorded.

- 2 Play the source and begin recording using the recording device connected to the REC jacks (TAPE and/or LINE 1) on the rear panel. See page 12.

Using the sleep timer

Use this feature to automatically set this unit to standby mode after a certain amount of time. The sleep timer is useful when you are going to sleep while this unit is playing or recording a source.

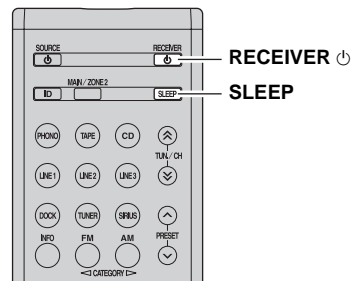
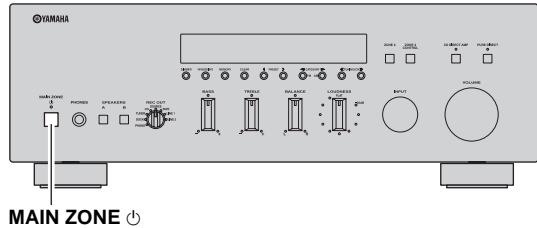

Notes

- The sleep timer can only be set with the remote control.
- The sleep timer automatically turns off Zone 2. However, Zone 2 components are not turned off.

- 1 Press SLEEP repeatedly to set the amount of time before this unit is set to standby mode. Each time you press SLEEP, the front panel display changes as shown below.

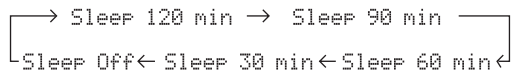



The SLEEP indicator blinks while setting the amount of time for the sleep timer.



If the sleep timer is set, the SLEEP indicator on the front panel display lights up.



- To disable the sleep timer, select "Sleep Off".
- The sleep timer setting can also be canceled by pressing RECEIVER  on the remote control (or MAIN ZONE  on the front panel) to set this unit to standby mode.

FM/AM TUNING

There are 2 tuning methods; automatic and manual. Select either method according to your preference and the strength of station signals.

Automatic tuning

Automatic tuning is effective when station signals are strong and there is no interference.

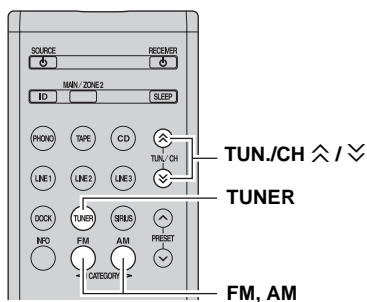
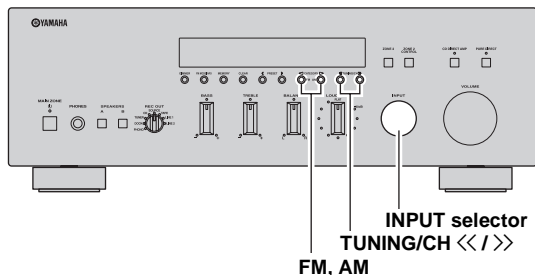

1 Rotate the **INPUT selector** on the front panel (or press **TUNER** on the remote control) to select **TUNER** as the input source.

2 Press **FM** or **AM** on the front panel (or **FM** or **AM** on the remote control) to select the reception band (**FM** or **AM**).

FM or AM is displayed on the front panel display.

3 Press and hold **TUNING/CH << / >>** on the front panel (or **TUN./CH ^ / v** on the remote control) for more than 1 second to begin automatic tuning.

Press **>>** (or **^**) to tune in to a higher frequency.

Press **<<** (or **v**) to tune in to a lower frequency.

Notes

- When you tune in to a station, the frequency of the station is displayed on the front panel display.
- If the tuning search does not stop at the desired station because the station signals are weak, try using the manual tuning method.

Auto Mute feature

When listening to an FM radio station, the output will automatically be muted when the radio signal is weak if the station was tuned in to by:

- using the automatic tuning feature
- recalling a preset that was registered using the automatic preset registration feature

If you want to listen to a station that has a weak signal, tune in to the station manually.

Manual tuning

Manual tuning is effective when station signals are weak.

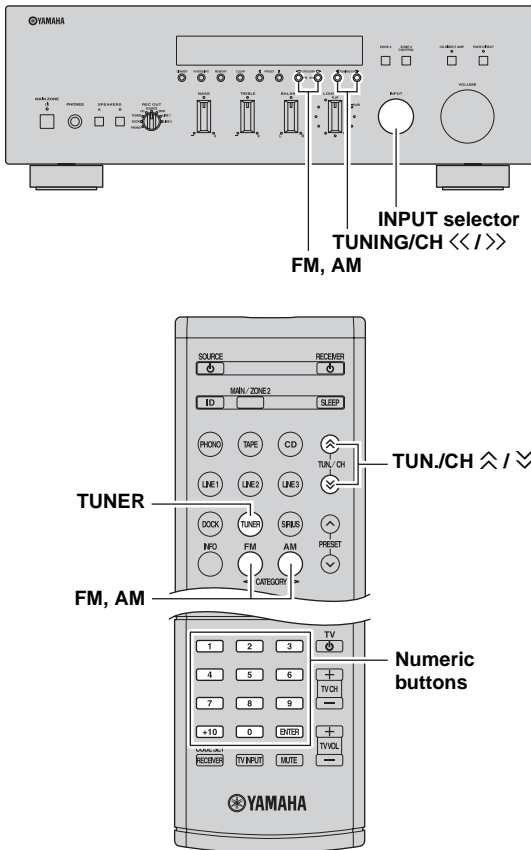

- 1 Rotate the **INPUT selector** on the front panel (or press **TUNER** on the remote control) to select **TUNER** as the input source.
- 2 Press **FM** or **AM** on the front panel (or **FM** or **AM** on the remote control) to select the reception band (**FM** or **AM**).
FM or AM is displayed on the front panel display.
- 3 Press **TUNING/CH <</>>** on the front panel (or **TUN./CH \wedge/\sphericalangle** on the remote control) to manually tune in to the desired station.

Note

When you tune in to a station, the frequency of the received station is shown in the front panel display.

- 4 To tune in by direct frequency tuning, press the **numeric buttons on the remote control** to enter the frequency of the station.

Enter only integers. For example, if you want to set the frequency to 88.9 MHz, enter “889”.

Notes

- When you press the numeric buttons on the remote control during preset tuning, a preset number is selected. Set the tuning mode to frequency tuning mode using **TUNING/CH <</>>** on the front panel (or **TUN./CH \wedge/\sphericalangle** on the remote control) before pressing the numeric buttons.
- “WRONG STATION!” is displayed on the front panel display if you enter a frequency that is out of receivable range. Make sure that the entered frequency is correct.

Improving FM reception

If the signal from the station is weak and the sound quality is not good, set the FM band reception mode to monaural mode to improve reception.

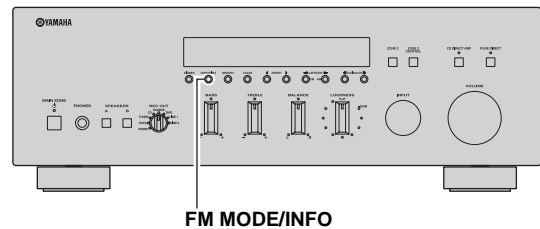

- 1 Press **FM MODE/INFO** on the front panel repeatedly to select “**STEREO**” (automatic stereo mode) or “**MONO**” (monaural mode) when this unit is tuned in to an FM radio station.
 - When **MONO** is selected, FM broadcasts will be heard in monaural sound.
 - When **STEREO** is selected and an FM station with a stereo broadcast is tuned in, the broadcast will be heard in stereo.

Note

The **STEREO** indicator on the front panel lights up while listening to a station in stereo.



The FM band reception mode (monaural or stereo) can also be changed by selecting FM Mode in the Option menu (see page 40).

Automatic station preset (FM stations only)

You can use the automatic station preset function to automatically register FM stations as presets. This function enables this unit to automatically tune in to FM stations that have a strong signal and store up to 40 of those stations in order. You can then easily recall any preset station by selecting its preset number.

Notes

- If a station is registered to a preset number that already has a station registered to it, the previously registered station is overwritten.
- If the station you want to store is weak in signal strength, try using the manual preset tuning method.



FM stations registered as presets using the automatic preset registration feature will be heard in stereo.

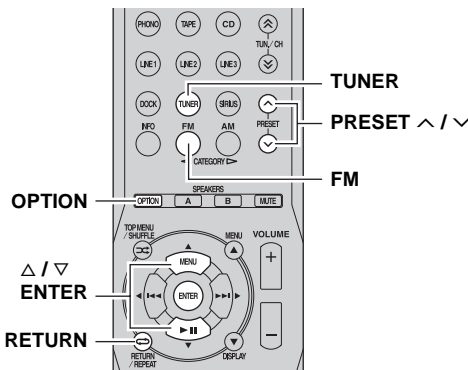
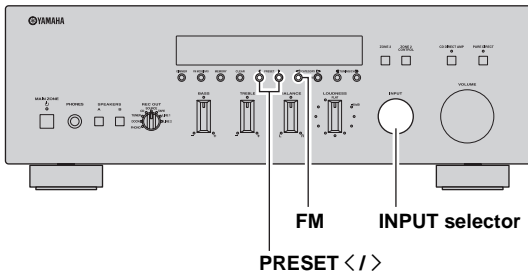

1 Rotate the **INPUT selector** on the front panel (or press **TUNER** on the remote control) to select **TUNER** as the input source.

2 Press **FM** on the front panel (or **FM** on the remote control) to select **FM** as the reception band.

FM is displayed on the front panel display.

3 Press **OPTION** on the remote control.

The Option menu for **TUNER** is displayed (see page 40).

4 Press **Δ / ▽** on the remote control to select “**Auto Preset**”, and then press **ENTER**.



This unit starts scanning the FM band about 5 seconds later from the lowest frequency upwards.



- Before scanning begins, you can specify the first preset number to be used by pressing **PRESET < / >** on the front panel (or **PRESET ^ / v** or **Δ / ▽** on the remote control).
- To cancel scanning, press **FM** or **AM** on the front panel (or **FM** or **AM** or **RETURN** on the remote control).

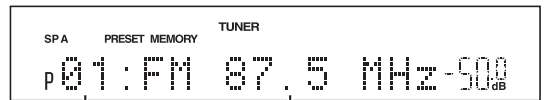

Preset number **Frequency**

When presets are registered, information is displayed on the front panel display as shown in the illustration above.

When scanning is complete, “**FINISH**” is displayed and then the display returns to the Option menu.

To return the display to the original state, press **OPTION** or **RETURN** on the remote control.

Manual station preset

You can manually register up to 40 FM/AM stations (40 total). You can then easily recall any preset station by selecting its preset number.

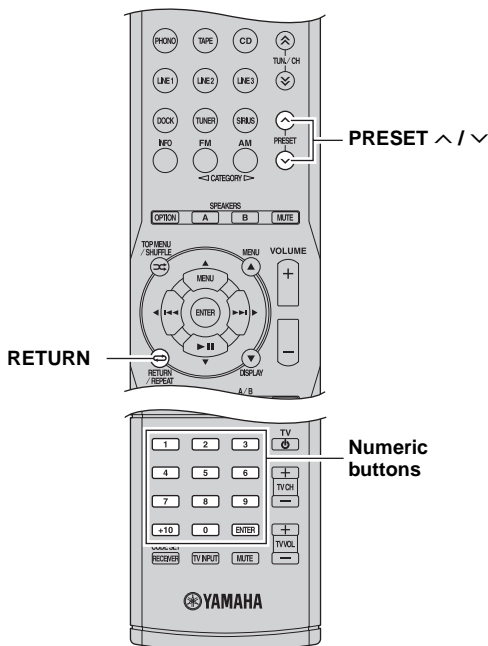
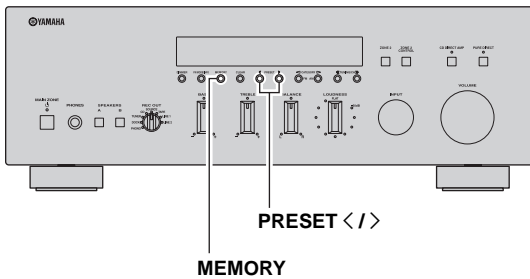

- 3 Press **PRESET </>** on the front panel (or **PRESET ^ / v** on the remote control) to **select the preset number to which the station will be registered.**

When you select a preset number to which no station is registered, "EMPTY" is displayed. When you select a preset number to which a station has already been registered, the frequency of the station is displayed.

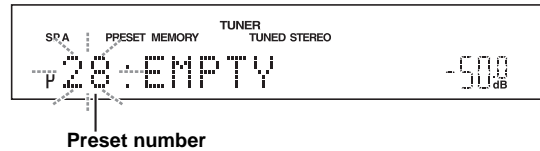

You can also select a preset number using the numeric buttons on the remote control.

- 4 Press **MEMORY** on the front panel.

When registration is complete, the display returns to the original state.



To cancel registration, RETURN on the remote control or do not perform any operations for about 30 seconds.

- 1 **Tune in to the desired FM/AM station.**

See pages 20 and 21 for tuning instructions.

- 2 **Press MEMORY on the front panel.**

"MANUAL PRESET" is displayed briefly on the front panel display, and then the preset number to which the station will be registered is displayed.

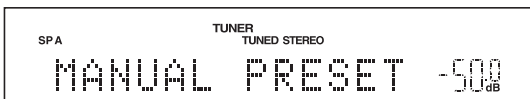

By holding down MEMORY on the front panel for more than 2 seconds, you can skip the following steps and automatically register the selected station to an empty preset number (i.e., the preset number following the last preset number used).

Recalling a preset station

You can recall preset stations that were registered using automatic station preset or manual station preset.

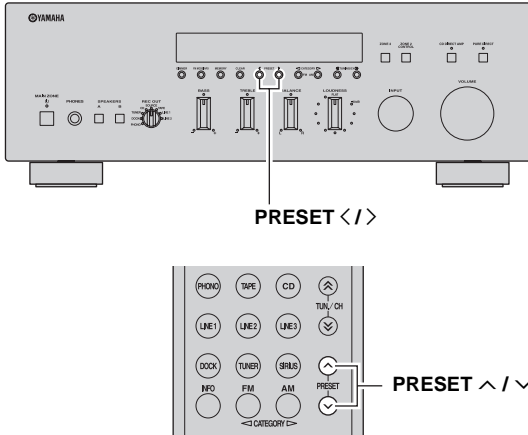

- 1 Press **PRESET </>** on the front panel (or **PRESET ^ / v** on the remote control) to select a preset number.



- Preset numbers to which no stations are registered are skipped.
- “NO PRESETS” is displayed if no stations are registered.
- You can directly select a preset number by pressing the numeric buttons on the remote control while recalling a preset station. “EMPTY” is displayed on the display if you enter a preset number to which no station is registered. “WRONG NUM.” is displayed if you enter an invalid number.
- When you press the numeric buttons on the remote control during normal tuning, a frequency is entered. Set the tuning mode to preset tuning mode using **PRESET </>** on the front panel (or **PRESET ^ / v** on the remote control) before pressing numeric buttons.

Clearing a preset station

Follow the steps below to clear a preset station.

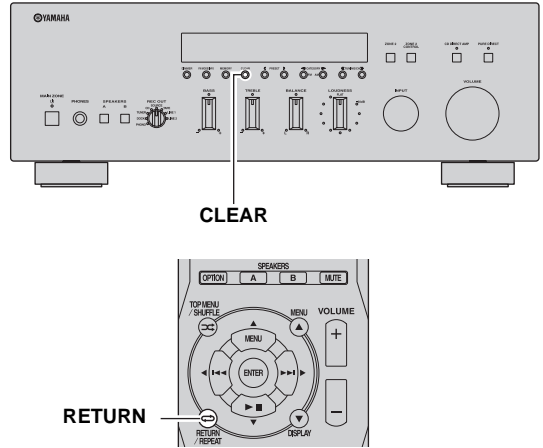

- 1 Select the desired preset station number. See “Recalling a preset station” on page 24.

- 2 Press **CLEAR** on the front panel.

The selected preset number flashes on the front panel display.

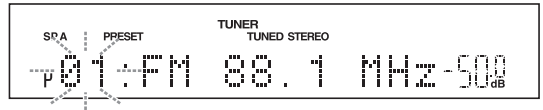

To cancel clearing the preset station, press **RETURN** on the remote control or leave this unit without any operations for about 30 seconds.

- 3 Press **CLEAR** on the front panel to confirm.

“PXX: CLEARED” (XX indicates the preset number) is displayed on the front panel display, and then the display returns to its original state.

Clearing all preset stations

Follow the steps below to clear all preset stations.

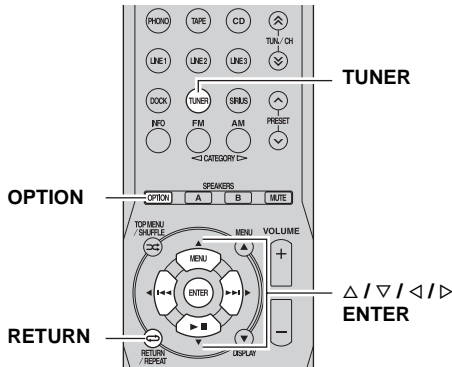
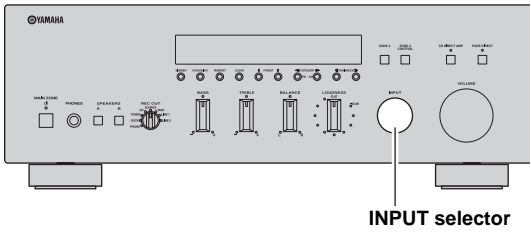

1 Rotate the INPUT selector on the front panel (or press TUNER on the remote control) to select TUNER as the input source.

2 Press OPTION on the remote control.

The Option menu for TUNER is displayed (see page 40).

3 Press Δ / ∇ on the remote control to select “Clr All Preset”, and then press ENTER.

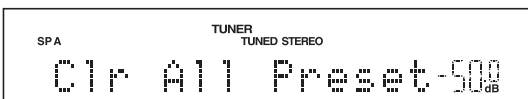

To cancel the operation and return to the Option menu, press RETURN on the remote control.

4 Press $\triangle / \triangleright$ on the remote control to select “YES”, and then press ENTER.

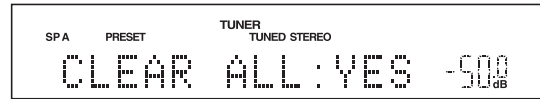

To cancel without clearing the presets, select “NO”.

When all presets have been cleared, “PRESET CLEARED” is displayed, and then the display returns to the Option menu.

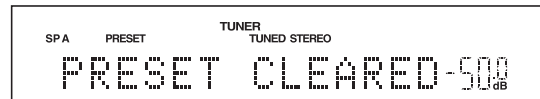

5 To exit the Option menu, press OPTION or RETURN on the remote control.

LISTENING TO SIRIUS Satellite Radio™

Listening to Satellite Radio

To listen to Satellite Radio, you'll need to connect a SIRIUS Satellite Radio tuner (sold separately) to your Sirius-Ready receiver. SIRIUS Satellite Radio is available to residents of the US (except Alaska and Hawaii) and Canada.

Satellite Radio delivers a variety of commercial-free music from categories ranging from Pop, Rock, Country, R&B, Dance, Jazz, Classical and many more plus coverage of all the top professional and college sports including play by play games from select leagues and teams. Additional programming includes expert sports talk, uncensored entertainment, comedy, family programming, local traffic and weather and news from your most trusted sources.

Once you've purchased a SIRIUS tuner you'll need to activate it and subscribe to begin enjoying the service. Easy to follow installation and setup instructions are provided with the SIRIUS tuner. There are a variety of programming packages available, including the option of adding "The Best of XM" programming to the SIRIUS service. The "Best of XM" service is not available to SIRIUS Canada subscribers at this time. Please check with SIRIUS Canada for any updates using the numbers and web address below.

Family friendly packages are also available to restrict channels featuring content that may be inappropriate for children.

To subscribe to SIRIUS, U.S. and Canadian customers can call 1-888-539-SIRI (1-888-539-7474) or visit sirius.com (US) or siriuscanada.ca (Canada).

SIRIUS Radio Legal

SIRIUS and all related marks and logos are trademarks of Sirius XM Radio Inc. and its subsidiaries. All other marks and logos are the property of their respective owners. All rights reserved. SIRIUS subscription sold separately. Taxes and a one-time activation fee may apply. SIRIUS tuner required (sold separately) to receive the SIRIUS service. All programming and fees subject to change. It is prohibited to copy, decompile, disassemble, reverse engineer, hack, manipulate or otherwise make available any technology or software incorporated in receivers compatible with the SIRIUS Satellite Radio System. **Service not available in Alaska or Hawaii.**

Connecting the SiriusConnect™ tuner

Connect the SiriusConnect tuner (sold separately) to the SIRIUS jack on the rear panel of this unit. For details, see the instruction manuals provided with the SiriusConnect tuner.

SiriusConnect Tuner and the antenna (sold separately)

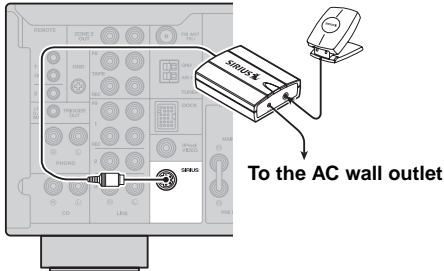

- To ensure optimal reception of SIRIUS Satellite Radio signals, the antenna of the SiriusConnect tuner must be placed at or near a window with no obstacles in the path to the sky. You can mount it indoors or outdoors. The orientation of the antenna for the best reception differs depending on the area. Refer to the instruction manuals provided with the SiriusConnect tuner for information about antenna installation.
- Use the “Antenna” information on the front panel display (see page 34) to check the antenna reception level and adjust the orientation of the antenna.
- You need to connect the SiriusConnect tuner to the AC wall outlet.

Notes

- If “CHECK SR TUNER” or “ANTENNA ERROR” is displayed on the front panel display, the SiriusConnect tuner or antenna is not connected correctly. In such cases, check the connection of the SiriusConnect tuner and the antenna.
- If “NOT SUPPORTED” is displayed on the front panel display, this unit does not support the connected SiriusConnect tuner.

Activating SIRIUS Satellite Radio™ subscription

Before using the SIRIUS Satellite Radio feature, you need to activate your SIRIUS Satellite Radio subscription. To activate the subscription you need the Sirius ID which is uniquely assigned to the SiriusConnect tuner. A Sirius ID is 12-digit number which is indicated on the package of the SiriusConnect tuner and on the label of the SiriusConnect tuner. The Sirius ID is also displayed on the front panel display when you tune in to the SIRIUS Satellite Radio channel “0”.

■ Displaying the Sirius ID of your SiriusConnect tuner

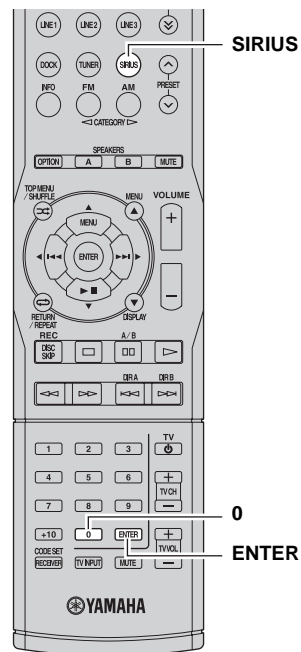
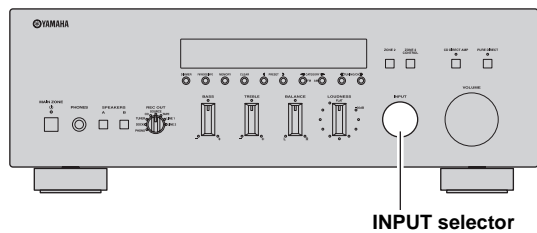

1 Rotate the INPUT selector on the front panel (or press SIRIUS on the remote control) to select SIRIUS as the input source.

2 Press 0 on the remote control and then ENTER to display the Sirius ID of your SiriusConnect tuner.

“000 Sirius ID” and “xxxxxxxxxxxx” is displayed alternately on the front panel display. (“xxxxxxxxxxxx” indicates the 12-digit Sirius ID of your SiriusConnect tuner.)
Write the Sirius ID below.

ID: _____

3 Contact SIRIUS Satellite Radio to activate your subscription.

SIRIUS Satellite Radio online information

Contact for activation

URL: <https://activate.siriusradio.com/>

Phone: 1-888-539-SIRIUS (1-888-539-7474)



Status messages are displayed on the front panel display during the activation. For details, see “SIRIUS Satellite Radio™” on page 53. Once the activation is finished, “SUB UPDATED” appears.

SIRIUS Satellite Radio™ operations

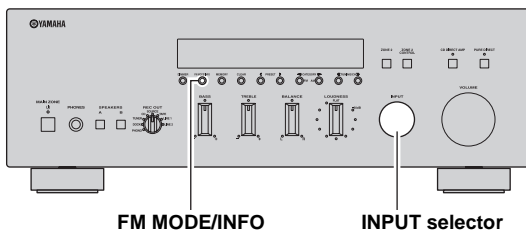

FM MODE/INFO

INPUT selector

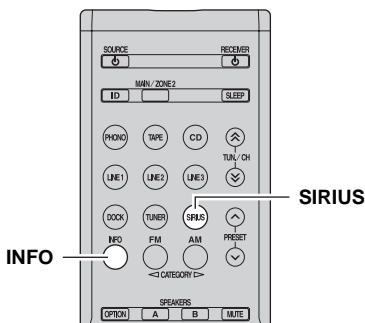

INFO

SIRIUS

1 Rotate the INPUT selector on the front panel (or press SIRIUS on the remote control) to select SIRIUS as the input source.

The SIRIUS indicator lights up on the front panel display and the SIRIUS Satellite Radio information (such as channel number, channel name, category, artist name, or song title) for the currently selected channel is displayed on the front panel display.



Channel number

Channel name



- When you select SIRIUS as the input source, this unit automatically recalls the previously selected channel.
- You can change the SIRIUS Satellite Radio information that is displayed by pressing FM MODE/INFO on the front panel (or INFO on the remote control) (see page 34).

Notes

- If you have not activated your subscription yet, you can only select “184” or “000”.
- If a status message or an error message is displayed on the front panel display, see “SIRIUS Satellite Radio™” (see page 53).

2 Search for a channel by using one of the SIRIUS Satellite Radio search modes.

- All channel search mode
Selects a channel from a list of all channels (see page 29).
- Category search mode
Selects a channel by category (see page 29).
- Direct number access mode
Selects a channel directly by channel number (see page 30).
- Preset search mode
Selects a channel from the preset channels (see page 31).
You can register channels as presets and then easily recall any preset channel by selecting its preset number.



- You can display SIRIUS Satellite Radio information on the front panel display (see page 34).
- If you tune in to a channel that you do not subscribe to, "CALL 888-539-SIRIUS TO SUBSCRIBE" scrolls across the front panel display, and then "CALL SIRIUS" is displayed.
- You can register SIRIUS Satellite Radio channels as presets (see page 30).

■ All channel search mode

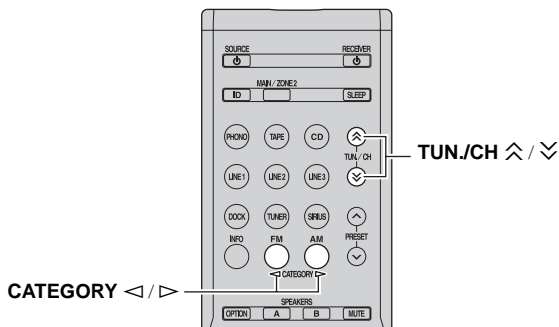
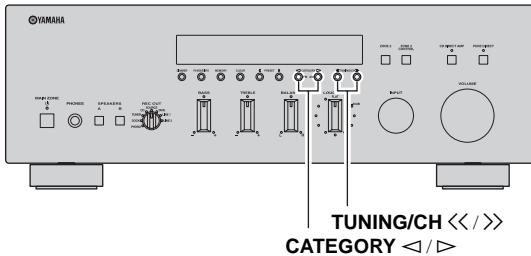

- 1 Press TUNING/CH <</>> on the front panel (or TUN./CH \wedge/\sphericalangle on the remote control) repeatedly to search for a channel from a list of all channels.

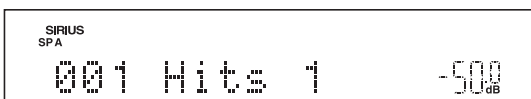

- You can search for a channel quickly by holding down TUNING/CH <</>> on the front panel (or TUN./CH \wedge/\sphericalangle on the remote control).
- You can skip to channels in the previous or next category by pressing CATEGORY </> on the front panel (or CATEGORY </> on the remote control).

■ Category search mode

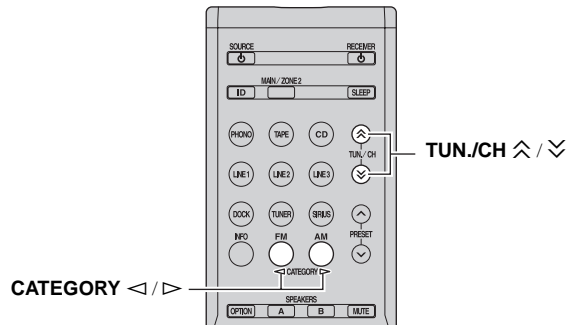
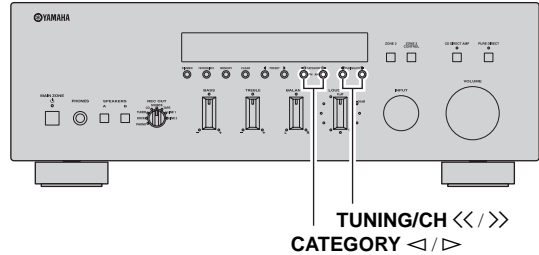

- 1 Press CATEGORY </> on the front panel (or CATEGORY </> on the remote control) to select a channel category.

The CATEGORY indicator lights up in the front panel display when selecting a category. When you select a category, the first channel in the category is selected.

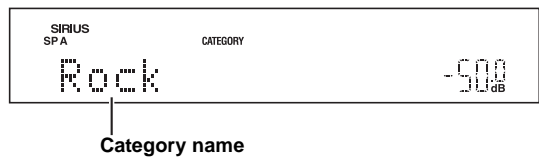

You can search for a channel category quickly by pressing and holding CATEGORY </> on the front panel (or CATEGORY </> on the front panel).

Note

If no operations are performed for 10 seconds, the search mode returns to the all channel search mode.

- While the CATEGORY indicator on the front panel display is lit, press TUNING/CH <</>> on the front panel (or TUN./CH ^ / v on the remote control) repeatedly to search for a channel within the selected channel category.



- You can search for a channel quickly by pressing and holding TUNING/CH <</>> on the front panel (or TUN./CH ^ / v on the remote control).
- In the category search mode, you can only search for a channel within the selected channel category.

Note

This unit skips the following channels in all channel search mode or category search mode. This is not a malfunction.

- channels that are locked (see page 32)
- channels that are not currently in service
- channels that you do not subscribe to

■ **Direct number access mode**

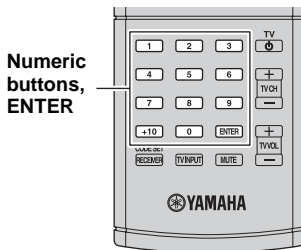

- Press the numeric buttons on the remote control to enter the desired three-digit channel number.

For example, to enter the number 123, press the numeric buttons “1,” “2” and then “3”.



- To entering a one-digit or two-digit channel number, enter the number using the numeric buttons and then press ENTER on the remote control to confirm your entry.
- This unit automatically accepts your entry if you do not press ENTER on the remote control within a few seconds after entering the number.
- If the selected channel is locked, “PIN: ___” is displayed on the front panel display. Enter the 4-digit Parental Lock code number by using the numeric buttons or press ENTER on the remote control to cancel (see page 32).
- If the selected channel is not available, an advisory message may be displayed. For details, refer to “SIRIUS Satellite Radio™” (see page 53).
- If this unit is in preset search mode, a preset number is selected instead of a channel number when you press the numeric buttons on the remote control. To switch to direct number access mode, press TUNING/CH <</>> on the front panel (or TUN./CH ^ / v on the remote control).

Registering and recalling SIRIUS Satellite Radio™ channels

Up to 40 SIRIUS Satellite Radio channels can be registered as preset channels.

■ **Registering preset channels**

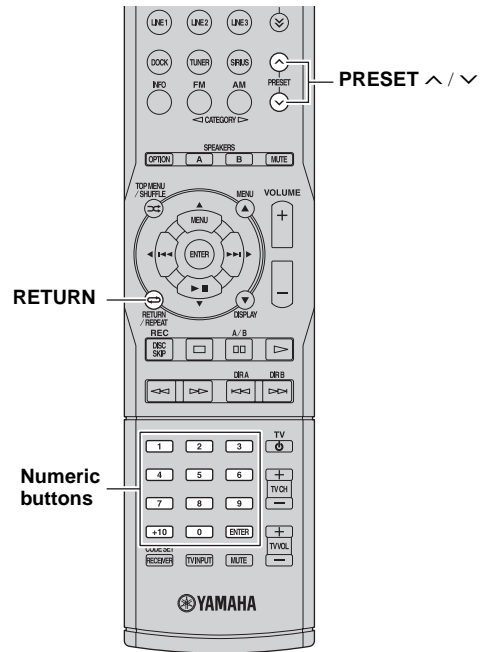
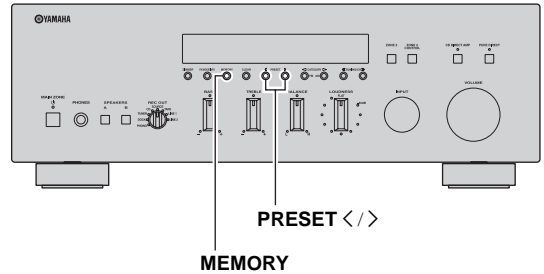

- Search for a channel to be registered.

For details on searching channels, refer to the following pages.

- All channel search mode (see page 29)
- Category search mode (see page 29)
- Direct number access mode (see page 30)

2 Press MEMORY on the front panel.

The indicator on the front panel display changes as follows.

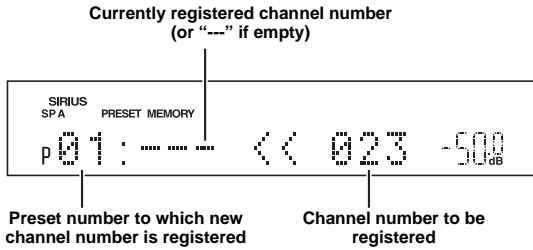

- By holding down MEMORY on the front panel for more than 2 seconds, you can skip the following steps and automatically register the selected channel to an empty preset number (i.e., the preset number following the last preset number used).
- To cancel registration, press RETURN on the remote control or do not perform any operations for about 30 seconds.

3 Press PRESET </> on the front panel (or PRESET ^ / v on the remote control) to select preset number.



- You can also select a preset number using the numeric buttons on the remote control.
- If you select a preset number that is being used (i.e., if the currently registered channel number is displayed next to the preset number), the current preset will be overwritten.

4 Press MEMORY on the front panel.

■ Recalling a preset channel (Preset Search mode)

You can recall preset channels by specifying their preset numbers.

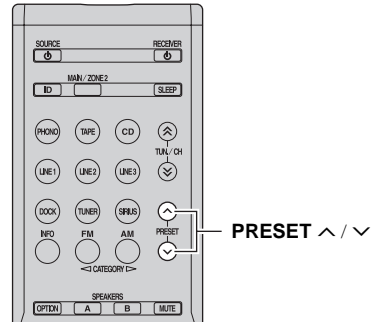
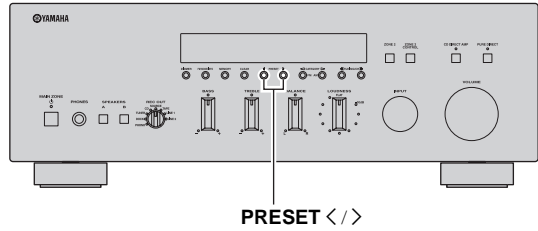

1 Press PRESET </> on the front panel (or PRESET ^ / v on the remote control) repeatedly to change the preset number (1 to 40).

■ Clearing a preset channel

Follow the steps below to clear a preset channel one at a time.

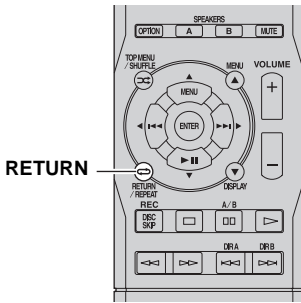
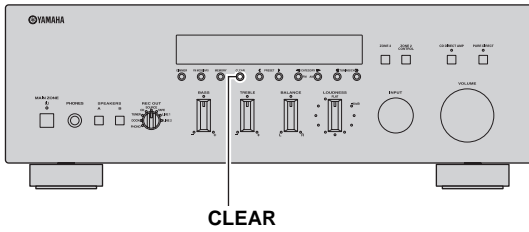

1 Select the desired preset.

See “Recalling a preset channel (Preset Search mode)” on page 31.

2 Press CLEAR on the front panel.

The selected preset number flashes on the front panel display.

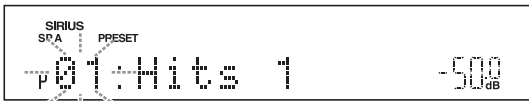

To cancel clearing the preset channel, press RETURN on the remote control or leave this unit without any operations for about 30 seconds.

3 Press CLEAR on the front panel to confirm.

“PXX: CLEARED” (XX indicates the preset number) is displayed on the front panel display, and then the display returns to its original state.

Setting the Parental Lock

You can use the Parental Lock feature to limit access to certain SIRIUS Satellite channels. This unit automatically skips the locked channels when this unit is in the all channel search mode or category search mode and you search for a channel by pressing TUNING/CH << / >> on the front panel (or TUN./CH ⤴ / ⤵ on the remote control).

■ Setting the code number and locking/unlocking channels

Use this feature to set the Parental Lock code number (PIN) and select the channels to be locked or unlocked.

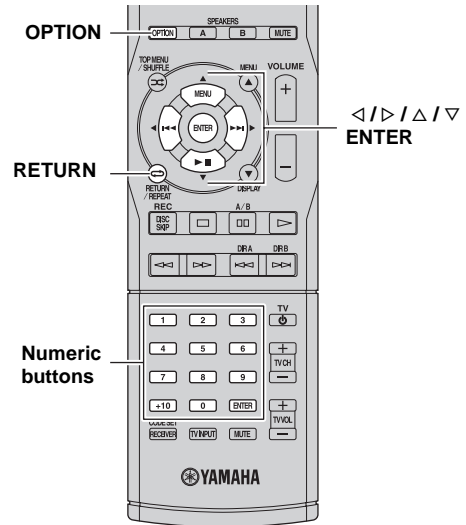

1 Press OPTION on the remote control.

The Option menu for SIRIUS is displayed.

2 Press Δ / ▽ on the remote control to select “Parental Lock”, and then press ENTER.

3 Use ◀ / ▶ (to select a digit to edit) and ▲ / ▼ (to select a number) on the remote control to enter the 4-digit code number.

- If you are entering a code number for the first time, enter the desired code number.
- If you have entered a code number before, enter the same code number.



The entered code number is needed for tuning in the channel or unlocking the channel. Write it down below.
Code number: _____



You can also enter the code number using the numeric buttons on the remote control.

4 Press ENTER on the remote control.



If the code number was entered for the first time, a confirmation message is displayed. Press ENTER again to confirm the code number.

The SIRIUS channel number and channel name are displayed on the front panel display.

Notes

- If a code number is already registered and you enter a different number, “WRONG” is displayed and the display returns to step 3. Enter the correct code number.
- If you forget the Parental lock code or want to change it, reset it using “SR PIN” (see page 43).

5 Search for a channel to be locked or unlocked.

For details on searching channels, refer to the following pages.

- All channel search mode (see page 29)
- Category search mode (see page 29)

Note

When searching for a channel, the sound of the selected channel can be heard even if the channel is locked.

6 Press ENTER on the remote control to lock or unlock the selected channel.

- If the selected channel is locked, the channel number and “LOCKED” are displayed on the front panel display.
- If the selected channel is unlocked, the front panel display changes from “LOCKED” to the channel name.



7 Repeat steps 5 and 6 to lock or unlock other channels as desired.

8 Press OPTION once or press RETURN repeatedly on the remote control to exit the “Parental Lock”.

- If the last channel you selected was locked, the unit tunes in to “184 Weather/Emergency” or “000 SIRIUS ID”.
- If the last channel you selected was unlocked, the unit tunes in to that channel.

■ Tuning in to the locked channels

Tune in to the channel using direct number access mode (see page 30) or preset search mode (see page 31). When you tune in to a locked channel “LOCKED” is displayed on the front panel display, followed by the following message. Enter the Parental lock code set previously by using the numeric buttons on the remote control. To cancel this operation, press ENTER on the remote control.

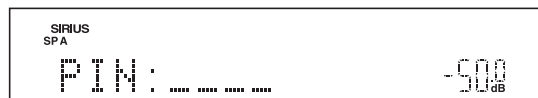
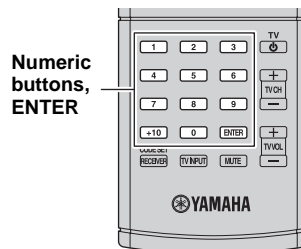

Note

If the number you entered does not match the code number, “WRONG” is displayed on the front panel display and this unit tunes in to the previously selected channel.

Displaying the SIRIUS Satellite Radio™ information

Use this feature to display the SIRIUS Satellite Radio information on the front panel display.

Note

If a status message or an error message is displayed on the front panel display, see “SIRIUS Satellite Radio™” on page 53.

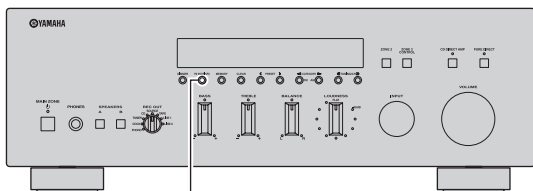

FM MODE/INFO

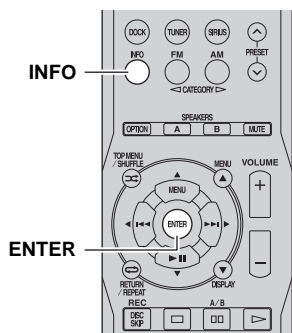

- 1 Press FM MODE/INFO on the front panel (or INFO on the remote control) repeatedly to switch between the following SIRIUS Satellite Radio information display modes.

CHANNEL
Channel number, channel name



CATEGORY
Channel category



ARTIST/SONG
Artist name, song title



COMPOSER
Composer name



ANTENNA
Antenna reception level



Back to “CHANNEL”

Display example (ANTENNA)

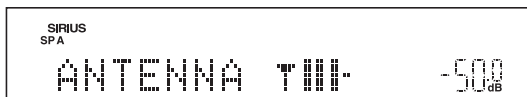

- If the SIRIUS Satellite Radio information contains a character that cannot be recognized by this unit, the character will be displayed as a space.
- When the antenna of the SiriusConnect tuner cannot receive the signals, “ACQUIRING” is displayed on the front panel display.
- When an information is unavailable, “—” is displayed.
- To hold or release the displayed information, press ENTER on the remote control. While it is held, the “HOLD” indicator flashes on the front panel display.

PLAYING BACK TUNES FROM YOUR iPhone/iPod/ Bluetooth™ COMPONENT

Once you have connected an optional Yamaha Universal Dock for iPod (such as the YDS-12), Wireless System for iPod (YID-W10), or Bluetooth Wireless Audio Receiver (YBA-10) to the DOCK jack on the rear panel of this unit, you can enjoy playback of your iPhone/iPod or Bluetooth component using the remote control supplied with this unit.

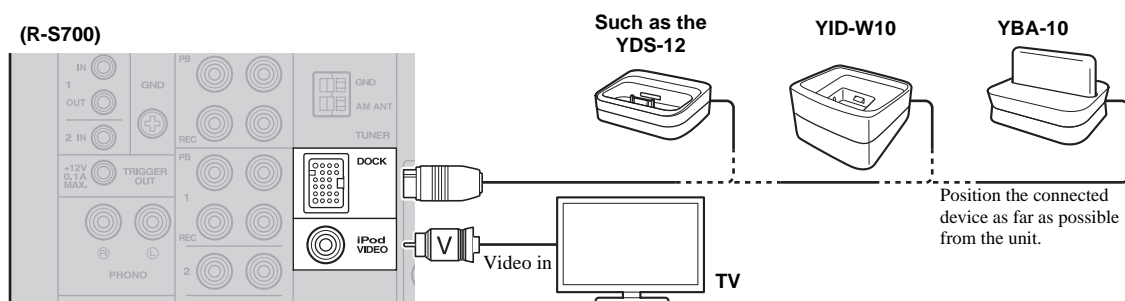

	Universal Dock for iPod	Wireless System for iPod	Bluetooth Wireless Audio Receiver
Model (As of July 2010)	<ul style="list-style-type: none"> • YDS-12 • YDS-11 • YDS-10 	YID-W10	YBA-10
This unit can play back	Audio and video	Only audio	Only audio
Operated by	<ul style="list-style-type: none"> • Remote control • Zone 2 Remote control (R-S700 only) • iPhone/iPod connected to the dock 	<ul style="list-style-type: none"> • iPhone/iPod connected to the YID-W10 transmitter • Remote control • Zone 2 Remote control (R-S700 only) 	Bluetooth components
Supported iPhone/iPod (As of July 2010)	<ul style="list-style-type: none"> • iPod touch • iPod (4th Gen/ 5th Gen/ classic) • iPod nano • iPod mini • iPhone • iPhone 3G • iPhone 3GS 	<ul style="list-style-type: none"> • iPod touch • iPod (5th Gen/ classic) • iPod nano • iPhone • iPhone 3G • iPhone 3GS 	/
Remarks	<ul style="list-style-type: none"> • Only the R-S700 supports video output. • The YDS-10 does not support video playback. • iPhone/iPod charging also supported. • The YDS-10/YDS-11 does not support iPhone connection. 	iPhone/iPod charging also supported.	/

CAUTION

To prevent accidents, unplug the power cable of this unit before connecting a Universal Dock for iPod, a Wireless System for iPod or a Bluetooth Wireless Audio Receiver.

Note

If the iPhone connected to the YID-W10 receives a call while this unit is in standby mode, the unit turns on automatically and the ringtone is heard through this unit. If you do not want this unit to turn on when a call is received, set the iPhone to silent mode.

Using a Universal Dock for iPod

■ Controlling your iPhone/iPod

After setting your iPhone/iPod in your dock, rotate the INPUT selector on the front panel (or press DOCK on the remote control) to select DOCK as the input source to play your iPhone/iPod.

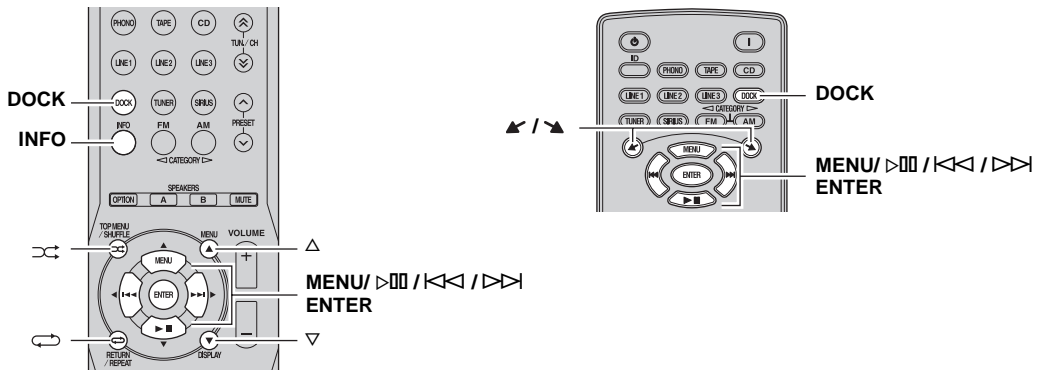

While viewing the information displayed on your iPhone/iPod, use the following remote control buttons to operate (playback, pause, skip, etc.) your iPhone/iPod.

Remote control	Zone 2 remote control (R-S700 only)	Operation
MENU	MENU	Displays the menu.
ENTER	ENTER	<ul style="list-style-type: none"> If an item is selected: Confirms the item and displays the next screen. If a song is selected: Plays the selected song.
△	▲	Scroll up.
▽	▼	Scroll down.
▷□□	▷□□	<ul style="list-style-type: none"> If a song is playing: Pauses the song. If a song is paused: Plays the song.
▷▷▷	▷▷▷	<ul style="list-style-type: none"> If a song is playing or paused: Skips to the beginning of the next song. If pressed and held: Searches forward.
◁◁◁	◁◁◁	<ul style="list-style-type: none"> If a song is playing or paused: Skips to the beginning of the current song. Pressing repeatedly skips one song backwards with each press. If pressed and held: Searches backward.
⌂ *		Switches between shuffle modes (Off → Songs → Albums → Off).
↻ *		Switches between repeat modes (Off → One → All → Off).
INFO*		Switches between items displayed on the front panel display of this unit (Song number and elapsed time → Songs → Artists → Albums → Song number and elapsed time).

Notes

- “*” indicates buttons that can be used to control the Main zone only.
- Some shuffle modes and repeat modes may not be available depending on the model or the software version of your iPhone/iPod.



When this unit is turned on or is in standby mode, your iPhone/iPod can be charged automatically if it is connected to a Universal Dock for iPod. The MAIN ZONE indicator remains brightly lit when an iPhone/iPod is being charged.

■ Playing videos from your iPhone/iPod (R-S700 only)

If a video monitor, such as a TV, is connected to this unit’s iPod VIDEO jack using a composite video cable, you can use the video monitor to watch videos stored on or streamed from your iPhone/iPod.

Note

iPhone/iPod operation screens are not displayed on the video monitor.

Using a Wireless System for iPod

By connecting a Wireless System for iPod to this unit, you can play songs on your iPhone/iPod and listen to them using a wireless connection.



You can use the remote control to control the iPhone/iPod. For more information, see page 36.

Note

When playing an iPhone/iPod using a Wireless System for iPod, playback information is not displayed on the front panel display.

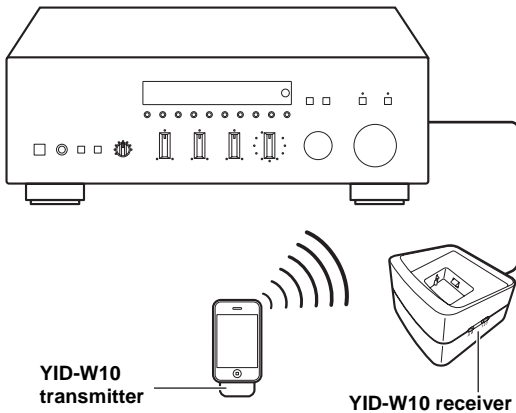

Establishing a wireless connection

Once the iPhone/iPod is connected to the YID-W10 transmitter and playback begins, it takes about 5 seconds for audio to be heard. During this time the wireless connection between the YID-W10 transmitter and receiver is established.

The status of the wireless connection between the YID-W10 transmitter and receiver is indicated by the respective indicator.

Status of Connection	YID-W10 transmitter indicator	YID-W10 receiver indicator
No connection	Off	Off
Confirming connection	Green, flashing	Blue, flashing
Connected	Green, lit	Blue, lit

Controlling this unit with your iPhone/iPod

- When playback begins on an iPhone/iPod that is connected to a YID-W10 transmitter, and if the YID-W10 transmitter is within range of the YID-W10 receiver, this unit performs as follows:
 - If this unit is already turned on when playback begins: The input source switches to DOCK.
 - If this unit is in standby mode when playback begins: This unit turns on and the input source switches to DOCK.
- In the following situations, the wireless connection between the transmitter and receiver is disconnected. After 30 seconds this unit automatically enters standby mode.
 - The iPhone/iPod is not operated for about 30–120 seconds after the playback is paused.
 - The sleep timer of the iPhone/iPod is activated.
 - The iPhone/iPod is disconnected from the YID-W10 transmitter.
 - The iPhone/iPod battery level decreases to a level where it cannot provide enough power to the YID-W10 transmitter.
 - The YID-W10 transmitter is moved outside of the wireless communication range of the YID-W10 receiver.
 - Communication between the YID-W10 transmitter and receiver becomes disrupted due to interference from other wireless LAN devices, cordless telephones, microwave ovens, etc.



These features can be disabled by setting “Interlock” to “OFF” in the Option menu (see page 42).

- Adjusting the volume on the iPhone/iPod also adjusts the volume of this unit. The iPhone/iPod can increase the volume to up to 0 dB (or the value set for the “MaxVol” setting in the Option menu). To further increase the volume, adjust the volume using this unit’s VOLUME control or the remote control.



- When this unit is turned on or is in standby mode, your iPhone/iPod can be charged automatically if the YID-W10 transmitter connected to your iPhone/iPod is stationed in the YID-W10 receiver. The MAIN ZONE indicator remains brightly lit when an iPhone/iPod is being charged.
- Refer to the operating instructions of the YID-W10 for more information.

Note

When the iPhone/iPod is used in Zone 2, these features are not available.

Using a Bluetooth Wireless Audio Receiver

Note

This unit supports A2DP (Advanced Audio Distribution Profile) and AVRCP (Audio and Video Remote Control Profile) of the Bluetooth profile.

■ Pairing Bluetooth™ components

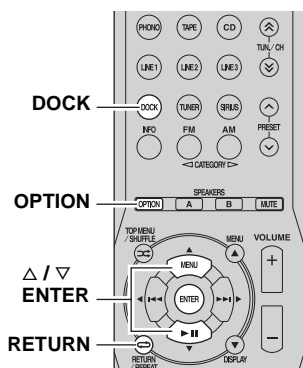
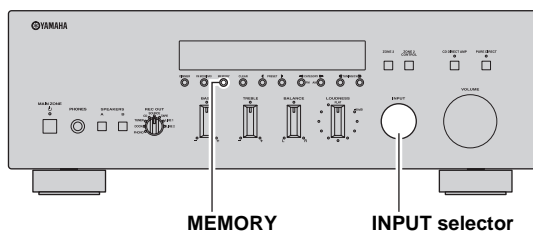

Be sure to pair the Bluetooth Wireless Audio Receiver and the Bluetooth component when connecting for the first time or when settings have been deleted.

Refer to the operating instructions of your Bluetooth component as necessary when carrying out pairing.

Note

The Bluetooth Wireless Audio Receiver can be paired with up to eight Bluetooth components. When the ninth device is paired, the pairing settings for the device which has not been used for the longest period of time will be deleted.

1 Rotate the INPUT selector on the front panel (or press DOCK on the remote control) to select DOCK as the input source.

2 Turn on the Bluetooth component you want to pair and set it to pairing mode.

3 Press OPTION on the remote control.

The Option menu for DOCK displayed (see page 40).

4 Press Δ / ∇ on the remote control to select “Pairing”, and then press ENTER.

“Searching...” is displayed and pairing begins.



To cancel pairing, press RETURN on the remote control.

5 Make sure the Bluetooth component recognizes the Bluetooth Wireless Audio Receiver.

When the component is recognized, it will be displayed in the Bluetooth component list, for example as “YBA-10 YAMAHA”.

6 Select the Bluetooth Wireless Audio Receiver from the Bluetooth component list, and enter a pass key “0000” using the Bluetooth component.

When pairing is complete, “Completed” is displayed on the front panel display.

To exit the Option menu, press OPTION on the remote control.



When the input source is set to DOCK, you can also begin pairing by pressing and holding MEMORY on the front panel (or ENTER on the remote control).

■ Playing back Bluetooth™ components

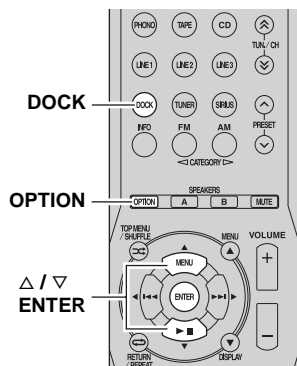
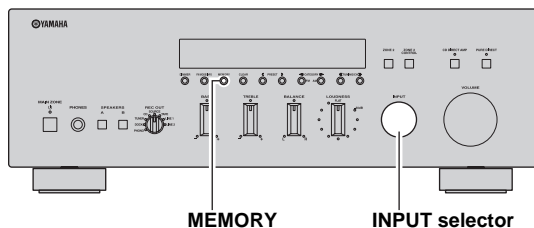

When pairing is complete, carry out the following procedure to achieve a wireless connection between this unit and the Bluetooth component.

When the wireless connection is complete, you can enjoy playback from Bluetooth components.

Note

Depending on the Bluetooth component, a wireless connection is established automatically or when the Bluetooth component is operated. In these cases, it is not necessary to carry out the following procedure.

1 Rotate the INPUT selector on the front panel (or press DOCK on the remote control) to select DOCK as the input source.

2 Press OPTION on the remote control.

The Option menu for DOCK displayed (see page 40).

3 Press Δ / ∇ on the remote control to select “Connect”, and then press ENTER.

When wireless connection is complete, “Connected” is displayed on the front panel display. To exit the Option menu, press OPTION on the remote control.



Note

“Not found” is displayed if there is a connection error. Check that the following conditions have been satisfied, and try to establish a wireless connection again.

- Both this unit and the Bluetooth component are paired.
- The Bluetooth component is switched on.
- The Bluetooth component is within 32 feet/10 meters of the Bluetooth wireless audio receiver.

4 Operate the Bluetooth component for playback.

While the Bluetooth component is playing, “BLUETOOTH” is displayed on the front panel display.



Note

To disconnect a wireless connection, repeat these steps and select “Disconnect” in step 3.



When the input source is set to DOCK, you can also establish a wireless connection by pressing MEMORY on the front panel (or ENTER on the remote control).

SETTING THE OPTION MENU FOR EACH INPUT SOURCE

The Option menu allows you to configure various settings for each input source and recall those settings automatically when an input source is selected. Also, you can view the signal information for certain input sources. The procedure for setting the Option menu items is described below.

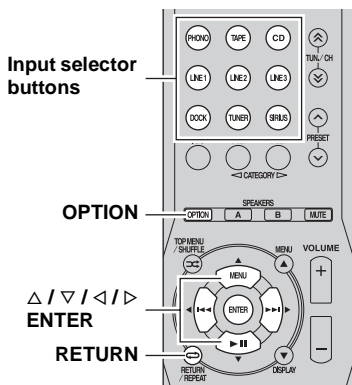
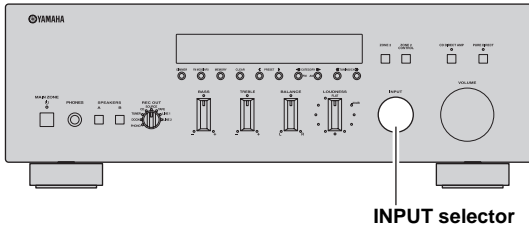

5 To exit the Option menu, press **OPTION** on the remote control.

To return to the previous menu, press **RETURN** on the remote control.

Note

If $\Delta / \nabla / \triangleleft / \triangleright$ on the remote control or other buttons do not work after closing the Option menu, rotate the INPUT selector on the front panel (or press one of the input selector buttons on the remote control) to select the current input source again.

Option menu items

The following menu items are provided for each input source.

Input source	Menu items
PHONO, CD, TAPE, LINE 1-3	Volume*1,
TUNER	Zone2 Volume*1*2, Trigger Out*1*2
SIRIUS	FM Mode, Auto Preset, Clr All Preset
DOCK (iPhone/iPod)	Parental Lock
DOCK (Bluetooth)	Interlock*3
	Connect, Disconnect, Pairing

1 Rotate the **INPUT selector** on the front panel (or press one of the input selector buttons on the remote control) to select the desired input source.

2 Press **OPTION** on the remote control.

Note

If the input source is changed while the Option menu is displayed, the front panel display exits the Option menu and the display for the selected input source is displayed.

3 Press Δ / ∇ on the remote control to select the desired menu item, and then press **ENTER**.

4 Press $\Delta / \nabla / \triangleleft / \triangleright$ on the remote control to change the settings.



For certain menu items, you must press **ENTER** to save the new setting.

Notes

*1 “Volume”, “Zone2 Volume”, and “Trigger Out” are common menu items for all input sources.

*2 “Zone2 Volume” and “Trigger Out” are available on the R-S700 only.

*3 “Interlock” is displayed in the Option menu only when using a Wireless System for iPod.

Details of the menu items are as follows. The configuration will be reflected to the input source currently selected.



The default settings are marked with “*”.

Volume

- Submenus:** Max Vol, IniVol
- Adjustable range (MaxVol):** -30.0dB to +15.0dB, +16.5dB* (5.0 dB step)
- Adjustable range (IniVol):** Off*, Mute, -89.5dB to +16.5dB (0.5 dB step)

Sets items for volumes.

Max Vol (Maximum volume)

Sets the maximum volume level so that the volume will not be accidentally increased above a certain level. For example, you can adjust the volume between -89.5 dB and -5.0 dB (or Mute) when you set this parameter to “-5.0dB”. The volume can be increased to the maximum level when this parameter is set to +16.5 dB (default).

IniVol (Initial volume)

Sets the volume at the time this unit is turned on. When this parameter is set to “Off”, the volume level used when this unit was set to standby is applied.

Note

If “MaxVol” is set to a value lower than the “IniVol” setting, the setting for “MaxVol” overrides the “IniVol” setting. For example, if you set “MaxVol” to “-30.0dB” and “IniVol” to “0.0dB”, the volume is automatically set to “-30.0dB” the next time this unit is turned on.

Zone2 Volume (R-S700 only)

- Submenus:** Max Vol, IniVol
- Adjustable range (MaxVol):** -30.0dB to +15.0dB, +16.5dB* (5.0 dB step)
- Adjustable range (IniVol):** Off*, Mute, -89.5dB to +16.5dB (0.5 dB step)

Sets the maximum volume level and initial volume level of Zone 2.

Max Vol (Maximum volume)

Sets the maximum volume level for Zone 2. Refer to “Max Vol (Maximum volume)” above.

IniVol (Initial volume)

Sets the volume at the time Zone 2 is turned on. Refer to “IniVol (Initial volume)” above.



The “ZONE 2” indicator on the front panel display flashes when the Zone2 volume is adjusted.

Note

If “MaxVol” is set to a value lower than the “IniVol” setting, the setting for “MaxVol” overrides the “IniVol” setting. For example, if you set “MaxVol” to “-30.0dB” and “IniVol” to “0.0dB”, the volume is automatically set to “-30.0dB” the next time this unit is turned on.

Trigger Out (R-S700 only)

- Submenu:** Mode
- Choices:** Power*, Source, Manual

Use this feature to select the functions of the TRIGGER OUT jack of this unit.

Power

Select this setting to send the voltage signals while the selected zone is turned on.

Source

Select this setting to send the voltage signals while the input source is selected.

Manual

Select this setting to send the voltage signals manually.

Note

The settings that are available depend on the mode (Power, Source, or Manual) that is selected.

Power: Zone

Source: Zone and Output level for each input source

Manual: Manual test

Zone

- Choices:** All*, Main, Zone 2

Select the zone to apply the setting you selected in “Mode”.

All

The “Mode” setting is applied to the Main zone and Zone 2.

Main

The “Mode” setting is applied to the Main zone only.

Zone 2

The “Mode” setting is applied to Zone 2 only.

Output level for each input source

Choices: High*, Low

Select the function of the TRIGGER OUT jack when the corresponding input source is selected.

High

Send the voltage signals when you select the input source you set in "Source".

Low

Stop sending the voltage signals when you select the input source you set in "Source".

Manual test (Manual)

Choices: High*, Low

Confirm that the component connected to the TRIGGER OUT jack operates when voltage signals are sent to the component. This setting is available only when "Mode" is set to "Manual".

High

Send the voltage signals.

Low

Stop sending the voltage signals.

FM Mode

Choices: STEREO*, MONO

Sets the FM broadcast receiving mode.

"FM Mode" is displayed in the Option menu only when TUNER is selected as the input source.

STEREO Receives in automatic stereo mode by priority.

MONO Receives in monaural mode. You can get a better reception in monaural mode.

Auto Preset

Automatically detects FM radio stations and registers them as preset stations (see page 22).

"Auto Preset" is displayed in the Option menu only when TUNER is selected as the input source.

Clr All Preset

Clears all preset stations (see page 25).

"Clr All Preset" is displayed in the Option menu only when TUNER is selected as the input source.

Parental Lock

Sets the Parental Lock (see page 32).

"Parental Lock" is displayed in the Option menu only when SIRIUS is selected as the input source.

Interlock

Choices: ON*, OFF

When an iPhone/iPod is connected to this unit wirelessly using a Wireless System for iPod, the iPhone/iPod can be used to turn this unit on, set it to standby mode or select DOCK as the input source.

"Interlock" is displayed in the Option menu only when using a Wireless System for iPod and DOCK is selected as the input source.

ON This unit responds to certain iPhone/iPod operations.

OFF Disables this feature.

Connect/Disconnect

Connects to or disconnects from a Bluetooth component (see page 39).

"Connect/Disconnect" is displayed in the Option menu only when DOCK (Bluetooth) is selected as the input source.

Pairing

Pairs the Bluetooth Wireless Audio Receiver and a Bluetooth component (see page 38).

"Pairing" is displayed in the Option menu only when DOCK (Bluetooth) is selected as the input source.

ADVANCED SETUP

■ ADVANCED SETUP menu parameters

Change the initial settings to reflect the needs of your listening environment.



The default settings are marked with “*”.

REMOTE ID

Choices: ID1, ID2*

Changes the remote control ID of this unit.

- Select ID1 to operate this unit using an alternative code.
- Select ID2 to operate this unit using the default code.

Note

The remote control's ID (see page 44) must be set to the same ID as this unit.

SR PIN (SIRIUS Personal Identification Number)

Choices: CANCEL*, RESET

Resets the Parental Lock code used to lock/unlock SIRIUS satellite radio channels.

APD (Automatic Power Down) TIMER

Choices: 4H (4 hours), 8H* (8 hours), 12H (12 hours)

When the POWER MANAGEMENT switch on the rear panel of this unit (see page 7) is set to ON, this unit's Main zone and Zone 2 automatically enters standby mode if this unit is not operated for the specified amount of time.

Note

When the POWER MANAGEMENT switch is set to OFF, “APD TIMER -OFF” is displayed.

INITIALIZE

Choices: NO*, YES

Resets all parameters to their factory presets.

- Select NO to cancel without resetting all parameters to their factory presets.
- Select YES to reset all parameters to their factory presets.

Note

If “YES” is selected the parameters are reset the next time you turn on the power of this unit.

Changing the ADVANCED SETUP menu parameters

The ADVANCED SETUP menu is displayed in the front panel display.



- Audio output is muted while setting parameters in the ADVANCED SETUP menu.
- While setting parameters in the ADVANCED SETUP menu, most controls on the front panel are disabled; only MAIN ZONE ⏻, the INPUT selector and FM MODE/INFO are operational.

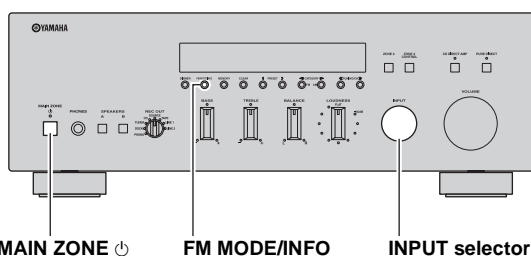

- 1 Press and hold FM MODE/INFO on the front panel, and then press MAIN ZONE ⏻.**
This unit turns on, and the ADVANCED SETUP menu is displayed on the front panel display.
- 2 Rotate the INPUT selector on the front panel to select the parameter you want to change.**
See “ADVANCED SETUP menu parameters” on page 43 for a complete list of available parameters.
- 3 Press FM MODE/INFO on the front panel repeatedly to change the selected parameter setting.**
To change other settings, repeat steps 2 and 3.
- 4 Press MAIN ZONE ⏻ to set this unit to standby mode to confirm your setting.**

Note

The settings you made take effect the next time you turn on this unit.

Switching the remote control ID

When using multiple Yamaha receivers or amplifiers with the same default code setting, you may unintentionally operate those components simultaneously. In this case, set one of the alternative codes for this unit to operate this unit separately.

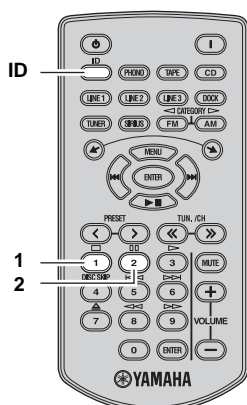
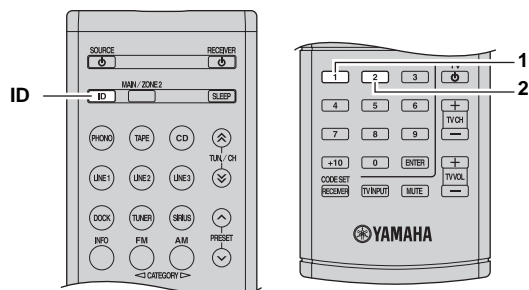

- Switching to ID1
Press and hold the ID button and the numeric button “1” on the remote control together for about 3 seconds.
- Switching to ID2
Press and hold the ID button and the numeric button “2” on the remote control together for about 3 seconds.

Remote control ID* (this unit's setting)	Function
ID1	To operate this unit using an alternative code.
ID2 (default setting)	To operate this unit using the default code.

* When you change the remote control ID, you must change the remote control ID of this unit (see page 43).

Note

If the remote control batteries are weak or removed, the remote control ID will switch to the default setting (ID2). In this case, replace the batteries and set the remote control ID again.

ZONE 2

Connecting Zone 2 components

This unit allows you to configure a multi-room audio system. The Zone 2 feature enables you to set this unit to reproduce separate input sources in the main room and in Zone 2 (the second room) simultaneously. You can control this unit from the second room using the supplied remote control.

The R-S700 can also be operated using the supplied Zone 2 remote control.

You need the following additional equipment to use the multi-room system of this unit:

- An infrared signal receiver for the second room.
- An infrared emitter for the main room. This emitter transmits the infrared signals sent by the remote control in Zone 2 to the components in the main room.
- An amplifier and speakers for the second room.



Some Yamaha models are able to connect directly to the REMOTE OUT jack on the rear panel of this unit. If you own one of these products, you may not need to use an infrared emitter. Up to six Yamaha components can be connected as shown below.

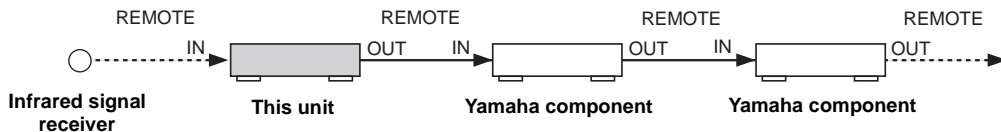

■ Multi-room configuration and connections

The following illustration shows an example of a multi-room system configuration and connections.

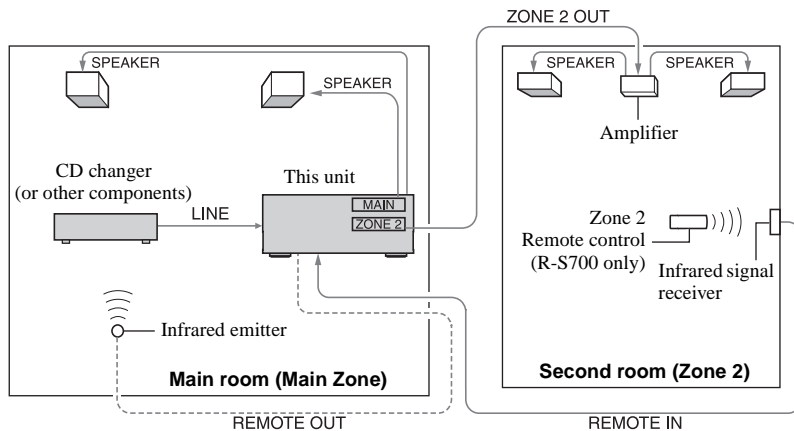

Since there are many possible ways to connect and use this unit in a multi-room configuration, we recommend that you consult with your nearest authorized Yamaha dealer or service center for the Zone 2 connections that best meet your requirements.

Note

If you want to adjust the Zone 2 volume level by using the amplifier in the second room, we recommend setting the Zone 2 volume level to or near 2.5 dB.

Controlling Zone 2

Use the supplied remote control, Zone 2 remote control (R-S700 only) or front panel to control the input source or adjust the sound output level of Zone 2 independently of the listening conditions in the main room.

* Sound output level can be adjusted on the R-S700 only.

Note

When using the R-S500, follow the procedure described in “Using the remote control” and “Using the front panel”.

■ Using the Zone 2 remote control (R-S700 only)

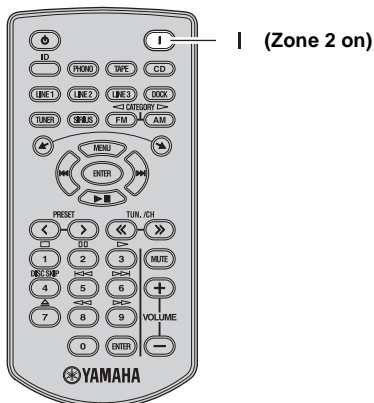

1 Press **1 (Zone 2 on)** on the Zone 2 remote control to turn on Zone 2.

2 Use the Zone 2 remote control as desired.

For information about each of the buttons on the Zone 2 remote control, see “Zone 2 remote control (R-S700 only)” on page 10.

■ Using the remote control

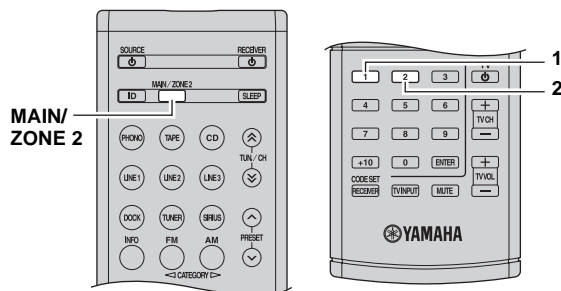

1 Change the zone that is operated by the remote control.

- To control the Main zone
Press and hold the MAIN/ZONE 2 button and the numeric button 1 on the remote control together for about 3 seconds.
- To control Zone 2
Press and hold the MAIN/ZONE 2 button and the numeric button 2 on the remote control together for about 3 seconds.

2 Use the remote control as desired.

For information about the buttons that can be used to control Zone 2, see “Remote control” on page 8. Buttons that can be used to control Zone 2 are indicated by “**ZONE**” on page 8.

■ Using the front panel

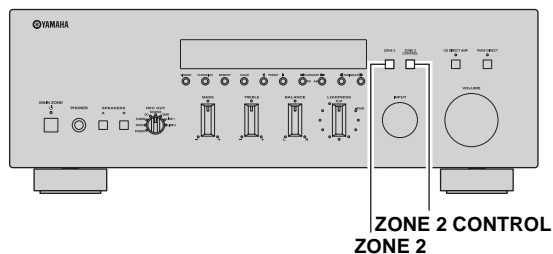

1 Press **ZONE 2** on the front panel to turn on Zone 2.

2 Press **ZONE 2 CONTROL** on the front panel to control Zone 2.

The ZONE 2 indicator on the front panel display blinks for about 10 seconds. During this time, you can control Zone 2 from the front panel. For information about the buttons and controls that can be used to control Zone 2, see “Front panel” on page 4. Buttons and controls that can be used to control Zone 2 are indicated by “**ZONE**” on page 4.

Notes

- When using only one TV: Assign the TV's remote control code to the TV \odot button. The TV control buttons always control your TV, regardless of the selected input source.
- To use other buttons (*1, above) to control your TV: Assign the TV's remote control code to the TV \odot button, and also to an input selector button. The TV control buttons always control your TV, regardless of the selected input source. You can use the other buttons to operate the TV by first pressing the input selector button to which the TV is assigned.
- To control more than one TV: Assign one TV to the TV \odot button and the other TVs to other input selector buttons. You can control the other TVs assigned by first pressing the input selector button to which a TV is assigned. You can use the TV control buttons to control the first TV whenever an input selector button with no TV assigned to it is selected.

■ Controlling other components

To use this unit's remote control to control other components (DVD player, VCR, etc.), determine the remote control code that corresponds to the component and assign that code to the desired input selector button on the remote control. For details about assigning remote control codes, see page 49.

To switch the input source and control the corresponding component, press the input selector button on the remote control, and then press the desired control button.



If you are unable to operate this unit after using the remote control to operate an external component, press RECEIVER and then try operating the remote control again.

The following table is an example of the component features that may be controlled using this remote control. Note that some features of the corresponding component may not be supported, and that some buttons may not correctly control the selected component.

Remote control	Feature (example)
[1] SOURCE \odot	Power
[2] TOP MENU	Title
[3] Δ	Up
∇	Down
\triangleleft	Left
\triangleright	Right
ENTER	Enter
[4] RETURN	Return
[5] DISC SKIP/REC	Disc skip (player) Rec (recorder)
\triangleright	Play
$\triangleleft \triangleleft$	Search backward
$\triangleright \triangleright$	Search forward
\square /A/B	Pause (player, recorder) Deck A/B (tape deck)
$\triangleleft \triangleleft$ /DIR A	Skip backward (player, recorder) Direction A (tape deck)
$\triangleright \triangleright$ /DIR B	Skip forward (player, recorder) Direction B (tape deck)
\square	Stop
[6] 1-9, 0, +10	Numeric buttons
[7] MENU	Menu
[8] DISPLAY	Display
[9] ENTER	Title/Index

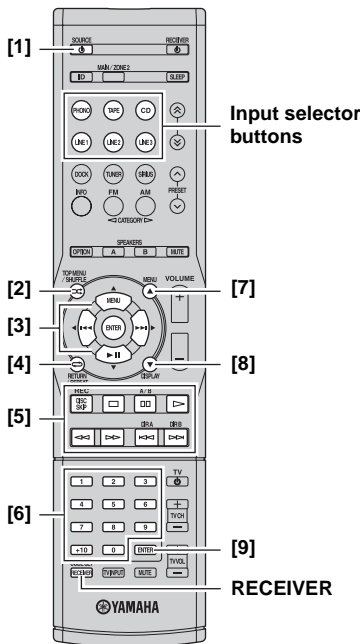

Configuring the remote control

To use this unit's remote control to control other components (TV, DVD player, VCR, etc.), determine the remote control code that corresponds to the component and assign that code to the desired input selector button on the remote control. Remote control codes are listed in the "LIST OF REMOTE CONTROL CODES" at the end of this manual.

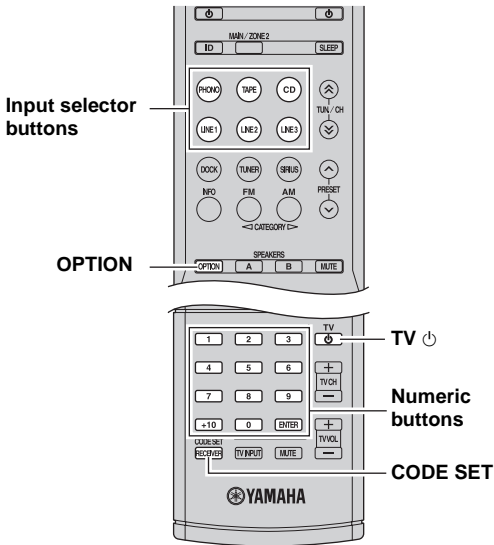

Default remote control configuration

The remote control is configured at the factory as shown below.

Button	Component category	Manufacturer	Default code
CD	CD player	Yamaha	5082
TAPE	TAPE deck	Yamaha	5087
PHONO	—	—	—
LINE 1	CD recorder	Yamaha	5083
LINE 2	DVD player	Yamaha	2082
LINE 3	Blu-ray disc player	Yamaha	2064
TV $\text{\textcircled{TV}}$	—	—	—

Note

If you cannot operate a Yamaha component when the remote control is configured using the remote control code listed above, refer to the "LIST OF REMOTE CONTROL CODES" at the end of manual and try assigning a different Yamaha remote control code.

Assigning remote control codes

- 1 Refer to the "LIST OF REMOTE CONTROL CODES" at the end of this manual and determine the remote control code that corresponds to each of your components. Components are listed by category (TV, VCR, DVD player, etc.) and manufacturer.
- 2 Press and hold CODE SET on the remote control for more than 3 seconds.
- 3 Press an input selector button on the remote control to select the input source you want to configure. You can also press TV $\text{\textcircled{TV}}$ to configure the TV control buttons (see page 47).
- 4 Use the numeric buttons on the remote control to enter the four-digit remote control code corresponding to the component you want to assign. When the component has been assigned, "OK" is displayed on the front panel display. If an error occurs, "NG" is displayed.

Notes

- If the manufacturer of your component has more than one remote control code, assign each code one at a time until you find the code that successfully controls your component.
- You can only assign one remote control code to each input selector button.

Resetting the remote control

Use this procedure to reset the remote control codes assigned to each input selector to the factory default (see "Default remote control configuration" above).

Note

This procedure will be cancelled if you do not press any buttons for 1 minute. If the procedure is cancelled, repeat from step 1 if necessary.

- 1 Press and hold CODE SET on the remote control for more than 3 seconds.
- 2 Press OPTION on the remote control.
- 3 Use the numeric buttons on the remote control to enter "9981".

The remote control code assigned to each input selector button will be reset to its factory default code.

TROUBLESHOOTING

Refer to the chart below if this unit does not function properly. If the problem you are experiencing is not listed below or if the instructions below do not help, set this unit to standby mode, disconnect the power cable, and contact the nearest authorized Yamaha dealer or service center.

■ General

Problem	Cause	Remedy	See page
This unit fails to turn on.	The power cable is not connected or the plug is not completely inserted.	Connect the power cable firmly.	—
	The impedance setting is incorrect.	Set the impedance to match your speakers.	13
	The protection circuitry has been activated because of a short circuit, etc.	Check that the speaker wires are not touching each other and then turn the power of this unit back on.	12
	The IMPEDANCE SELECTOR switch on the rear panel is not set to either end.	Set the IMPEDANCE SELECTOR switch to either end when the power of this unit is turned off.	13
	This unit has been exposed to a strong external electric shock (such as lightning or strong static electricity).	Set this unit to standby mode, disconnect the power cable, plug it back in after 30 seconds, then use it normally.	—
No sound	Incorrect input or output cable connections.	Connect the cables properly. If the problem persists, the cables may be defective.	12
	No appropriate input source has been selected.	Select an appropriate input source with the INPUT selector on the front panel (or one of the input selector buttons on the remote control).	16
	The SPEAKERS A/B switches are not set properly.	Turn on the corresponding SPEAKERS A or SPEAKERS B.	16
	Speaker connections are not secure.	Secure the connections.	12
	Output has been muted.	Turn off the mute.	8
	The MaxVol or IniVol setting is set too low.	Set the setting to a higher value.	40
	The component corresponding to the selected input source is turned off or is not playing.	Turn the component on and make sure it is playing.	—
The sound suddenly goes off.	The protection circuitry has been activated because of a short circuit, etc.	Check that the IMPEDANCE SELECTOR switch is set to the correct position.	13
		Check that the speaker wires are not touching each other and then turn the power of this unit back on.	12
	This unit has become too hot.	Make sure the openings on the top panel are not blocked.	—
	The automatic power down function has turned this unit off.	Change the automatic power down setting (“APD TIMER” in the Advanced Setup menu) to a longer setting, or disable the automatic power down function by setting the POWER MANAGEMENT switch on the rear panel to OFF.	43
Only the speaker on one side can be heard.	Incorrect cable connections.	Connect the cables properly. If the problem persists, the cables may be defective.	12
	Incorrect setting for the BALANCE control.	Set the BALANCE control to the appropriate position.	18
There is a lack of bass and no ambience.	The + and – wires are connected in reverse at the amplifier or the speakers.	Connect the speaker wires to the correct + and – phase.	12

Problem	Cause	Remedy	See page
A “humming” sound can be heard.	Incorrect cable connections.	Connect the audio plugs firmly. If the problem persists, the cables may be defective.	12
	No connection from the turntable to the GND terminal.	Make the GND connection between the turntable and this unit.	12
The volume level is low while playing a record.	The record is being played on a turntable with an MC cartridge.	The turntable should be connected to this unit through the MC head amplifier.	—
The volume level cannot be increased, or the sound is distorted.	The component connected to the TAPE REC or LINE 1 REC output jacks of this unit is turned off.	Turn on the power of the component.	—
The sound is degraded when listening with the headphones connected to the CD player or the tape deck connected to this unit.	The power of this unit is turned off, or this unit is set to standby mode.	Turn on the power of this unit.	16
The sound level is low.	The loudness control function is operating.	Turn down the volume, set the LOUDNESS control to the FLAT position, and then adjust the volume again.	18
The input source cannot be changed although the INPUT selector is rotated.	The CD DIRECT AMP switch is turned on (R-S700 only).	Turn off the CD DIRECT AMP switch.	17
Using the BASS, TREBLE, BALANCE and LOUDNESS controls does not affect the tonal quality.	The CD DIRECT AMP (R-S700 only) or the PURE DIRECT switch is turned on.	The CD DIRECT AMP or the PURE DIRECT switch must be turned off to use those controls.	17

■ Tuner

	Problem	Cause	Remedy	See page
FM	FM stereo reception is noisy.	The particular characteristics of the FM stereo broadcasts being received may cause this problem when the transmitter is too far away or the antenna input is poor.	Check the antenna connections. Try using a high-quality directional FM antenna.	14
			Switch to monaural mode.	21
	There is distortion, and clear reception cannot be obtained even with a good FM antenna.	There is multipath interference.	Adjust the antenna position to eliminate the multipath interference.	—
	The desired station cannot be tuned in with the automatic tuning method.	The signal is too weak.	Try using a high-quality directional FM antenna. Try using the manual tuning method.	14 21
FM/AM	NO PRESETS is displayed.	No preset stations are registered.	Register stations you want to listen to as preset stations before operation.	22
	WRONG STATION is displayed.	An invalid FM/AM frequency has been input.	Input a frequency that can be received.	21
AM	The desired station cannot be tuned in with the automatic tuning method.	The signal is weak or the antenna connections are loose.	Tighten the AM loop antenna connections and orient it for the best reception. Try using the manual tuning method.	— 21
	Automatic station preset does not work.	Automatic station preset is not available for AM stations.	Use manual station preset.	23
	There are continuous crackling and hissing noises.	The noises may result from lightning, fluorescent lamps, motors, thermostats or other electrical equipment.	Try using an outdoor antenna and a ground wire. This will help somewhat, but it is difficult to eliminate all noise.	—
	There are buzzing and whining noises.	A TV set is being used nearby.	Move this unit away from the TV set.	—

■ SIRIUS Satellite Radio™

The following messages may be displayed on the front panel display in certain situations.

Message	Status/Cause	Remedy	See page
ANTENNA ERROR	The antenna is not connected to the SiriusConnect tuner properly.	Check the connection of the antenna and SiriusConnect tuner.	27
SIRIUS LOADING	This unit is communicating with the SiriusConnect tuner.	The message disappears normally within several tens of seconds.	—
CHECK SR TUNER	The SiriusConnect tuner is not connected to the SIRIUS jack of this unit correctly.	Check the connection of the SiriusConnect tuner and this unit.	27
	The SiriusConnect tuner is not connected to the AC wall outlet.	Connect the power cable of the SiriusConnect tuner to the AC wall outlet.	—
NOT SUPPORTED	This unit does not support the connected SIRIUS Satellite Radio tuner.	Connect the SiriusConnect tuner that this unit supports,	—
ACQUIRING	The signal is too weak.	Adjust the orientation of the antenna of the SiriusConnect tuner. Check the antenna reception level from the Antenna information on the front panel display.	34
UPDATING	The SiriusConnect tuner is updating the channel list.	Wait until the updating is complete.	—
	The period of the subscription is end.	Contact SIRIUS Satellite Radio to renew the subscription.	—
F/W UPDATING	The SiriusConnect tuner is updating the firmware.	Wait until the updating is complete.	—
CALL SIRIUS (CALL 888-539-SIRIUS TO SUBSCRIBE)	The selected channel is not subscribed.	Contact SIRIUS Satellite Radio to subscribe the selected channel. URL: https://activate.siriusradio.com/ Phone: 1-888-539-SIRIUS (1-888-539-7474)	—
		Select another channel.	28
SUB UPDATED	The subscription information is updated.		—
INVALID	The selected channel is currently out of service.	Select another channel.	28
NOT AVAILABLE	The operation you made is not available.		—

■ **iPhone/iPod**

The following messages may be displayed on the front panel display in certain situations.

Message	Status/Cause	Remedy	See page
Connect error	There is a problem with the signal path from your iPhone/iPod to the unit.	Turn off the unit and reconnect the Universal Dock for iPod to the DOCK jack of the unit.	35
		Remove your iPhone/iPod from the Universal Dock for iPod and then place it back in the dock.	35
Unknown iPod	The iPhone/iPod being used is not supported by the unit.	Connect an iPhone/iPod supported by the unit.	35
Connected	Your iPhone/iPod is properly placed in the Universal Dock for iPod.		—
	Your iPhone/iPod is properly placed in the Wireless System for iPod and connected with this unit via wireless transmission.		37
Disconnected	Your iPhone/iPod is removed from the Universal Dock for iPod.		—
	Your iPhone/iPod is disconnected with this unit via wireless transmission.		—
	The wireless connection is poor.	Place the YID-W10 receiver as far away from this unit as possible.	35

Problem	Cause	Remedy	See page
When using the Universal Dock for iPod: Your iPhone/iPod is not being charged even though it is connected to the Universal Dock for iPod.	The iPhone/iPod is not connected securely.	Connect the iPhone/iPod securely to the Universal Dock for iPod.	—
When using the Wireless System for iPod: Your iPhone/iPod is not being charged even though the YID-W10 transmitter connected to your iPhone/iPod is stationed in the YID-W10 receiver.	The YID-W10 transmitter is not stationed securely in the YID-W10 receiver.	Station the YID-W10 transmitter connected to your iPhone/iPod securely in the YID-W10 receiver.	—

■ Bluetooth™

The following messages may be displayed on the front panel display in certain situations.

Message	Status/Cause	Remedy	See page
Searching...	The Bluetooth Wireless Audio Receiver and the Bluetooth component are in the process of pairing.		—
	The Bluetooth Wireless Audio Receiver and the Bluetooth component are in the process of establishing a connection.		—
Completed	The pairing is completed.		—
Canceled	The pairing is canceled.		—
Connected	The connection between the Bluetooth Wireless Audio Receiver and the Bluetooth component is established.		—
Disconnected	The Bluetooth component is disconnected from the Bluetooth Wireless Audio Receiver.		—
Not found	The Bluetooth component is not found.	During pairing: <ul style="list-style-type: none"> – pairing must be performed on the Bluetooth component and this unit simultaneously. Check if the Bluetooth component is in pairing mode. During connecting: <ul style="list-style-type: none"> – check if the Bluetooth component is turned on. – check if the Bluetooth component is within 10 m (32 feet) of the Bluetooth Wireless Audio Receiver. 	—
	Pairing may not have been achieved.	Try pairing again.	38

■ Remote control

Problem	Cause	Remedy	See page
The remote control does not work nor function properly.	Wrong distance or angle.	The remote control will function within a maximum range of 6 m (20 ft) and no more than 30 degrees off-axis from the front panel.	11
	Direct sunlight or lighting (from an inverter type of fluorescent lamp, etc.) is striking the remote control sensor of this unit.	Reposition this unit.	—
	The batteries are weak.	Replace all batteries.	11
	The remote control ID and this unit's ID do not match.	Switch the remote control ID or this unit's ID.	44
	The remote control code was not correctly set.	Try setting another code of the same manufacturer using "LIST OF REMOTE CONTROL CODES" at the end of this manual.	49
	Even if the remote control code is correctly set, there are some models that do not respond to the remote control.	Use the supplied remote control for the components.	—
	You did not press the input selector button corresponding to the component you are trying to control.	Press the input selector button corresponding to the component you are trying to control, and then press the desired remote control button(s).	—
	The remote control is not set to the correct zone.	Set the remote control to the correct zone, the Main zone or Zone 2, and then operate the remote control.	46
	If the remote control batteries are weak or removed, the remote control ID and zone will switch to the default settings (ID2 and Main zone).	Replace all batteries, and then set the remote control ID and zone again.	44, 46

SPECIFICATIONS

AUDIO SECTION

- Minimum RMS output power
 - [R-S700]
 - (8 Ω, 20 Hz to 20 kHz, 0.019% THD) 100 W + 100 W
 - (6 Ω, 20 Hz to 20 kHz, 0.03% THD) 120 W + 120 W
 - [R-S500]
 - (8 Ω, 20 Hz to 20 kHz, 0.04% THD) 75 W + 75 W
- Dynamic power per channel (IHF)
 - (8/6/4/2 Ω)
 - [R-S700] 140/170/220/290 W
 - [R-S500] 105/125/150/178 W
- Maximum power per channel [Europe model only]
 - (1 kHz, 0.7% THD, 4 Ω)
 - [R-S700] 160 W
 - [R-S500] 105 W
- IEC power [Europe model only]
 - [R-S700] (1 kHz, 0.019% THD, 8 Ω) 115 W
 - [R-S500] (1 kHz, 0.04% THD, 8 Ω) 84 W
- Power band width
 - [R-S700] (0.06% THD, 50 W, 8 Ω) 10 Hz to 50 kHz
 - [R-S500] (0.06% THD, 37.5 W, 8 Ω) 10 Hz to 50 kHz
- Damping factor (SPEAKERS A)
 - 1 kHz, 8 Ω
 - [R-S700] 240 or more
 - [R-S500] 150 or more
- Maximum effective output power (JEITA)
 - [Asia (R-S500 only) and Central/South America models only]
 - [R-S700] (1 kHz, 10% THD, 8/6 Ω) 145/170 W
 - [R-S500] (1 kHz, 10% THD, 8 Ω) 115 W
- Input sensitivity/Input impedance
 - PHONO (MM) 3.5 mV/47 kΩ
 - CD, etc. 200 mV/47 kΩ
 - [R-S700] MAIN IN 1.0 V/47 kΩ
- Maximum input signal
 - PHONO (MM) (1 kHz, 0.003% THD) 60 mV or more
 - CD, etc. (1 kHz, 0.5% THD) 2.2 V or more
- Output level/Output impedance
 - CD, etc. (Input 1 kHz, 200 mV)
 - REC 200 mV/1.0 kΩ
 - CD, etc. (Input 1 kHz, 200 mV, 8 Ω)
 - PHONES 410 mV/470 Ω
- Frequency response
 - CD, etc. (20 Hz to 20 kHz) 0 ± 0.5 dB
 - [R-S700] CD, etc., PURE DIRECT on/MAIN IN
 - (10 Hz to 100 kHz) 0 ± 1.0 dB
 - [R-S500] CD, etc., PURE DIRECT on
 - (10 Hz to 100 kHz) 0 ± 1.0 dB
- RIAA equalization deviation
 - PHONO (MM) ± 0.5 dB
- Total harmonic distortion
 - PHONO (MM) to REC
 - (20 Hz to 20 kHz, 3 V) 0.025% or less
 - [R-S700]
 - CD, etc. to PRE OUT
 - (20 Hz to 20 kHz, 1 V) 0.005% or less
 - CD, etc. to SPEAKERS
 - (20 Hz to 20 kHz, 50 W, 8 Ω) 0.015% or less
 - [R-S500]
 - CD, etc. to SPEAKERS
 - (20 Hz to 20 kHz, 37.5 W, 8 Ω) 0.015% or less
- Signal to noise ratio (IHF-A network)
 - PHONO (MM) (5 mV input shorted) 85 dB or more
 - CD, etc., PURE DIRECT on
 - (200 mV input shorted) 100 dB or more
 - [R-S700] CD, CD DIRECT AMP on
 - (200 mV input shorted) 107 dB or more
- Residual noise (IHF-A network) 30 μV
- Channel separation
 - CD, etc. (5.1 kΩ input shorted, 1/10 kHz) 65/50 dB or more

- Tone control characteristics
 - BASS
 - Boost/Cut (50 Hz) ± 10 dB
 - Turnover Frequency 350 Hz
 - TREBLE
 - Boost/Cut (20 kHz) ± 10 dB
 - Turnover Frequency 3.5 kHz
- Continuous loudness control
 - Attenuation (1 kHz) -30 dB
- Gain tracking error (0 to -99 dB) 0.5 dB or less

FM SECTION

- Tuning range
 - [U.S.A. and Canada models] 87.5 to 107.9 MHz
 - [Asia (R-S500 only) and Central/South America models]
 - 87.5/87.50 to 107.9/108.00 MHz
 - [Europe, Russia and Australia models] 87.50 to 108.00 MHz
- 50 dB quieting sensitivity (IHF, 1 kHz, 100% MOD.)
 - Mono 3.0 μV (20.8 dBf)
- Signal to noise ratio (IHF)
 - Mono/Stereo 74 dB/70 dB
- Harmonic distortion (1 kHz)
 - Mono/Stereo 0.3%/0.3%

AM SECTION

- Tuning range
 - [U.S.A. and Canada models] 530 to 1710 kHz
 - [Asia (R-S500 only) and Central/South America models]
 - 530/531 to 1710/1611 kHz
 - [Europe, Russia and Australia models] 531 to 1611 kHz

GENERAL

- Power supply
 - [U.S.A. and Canada models] AC 120 V, 60 Hz
 - [Central/South America models]
 - AC 110-120/220-240 V, 50/60 Hz
 - [Australia model] AC 240 V, 50 Hz
 - [Europe and Russia models] AC 230 V, 50 Hz
 - [Asia model (R-S500 only)] AC 220-240 V, 50/60 Hz
- Power consumption
 - [R-S700]
 - [U.S.A. and Canada models] 270 W, 370 VA
 - [Other models] 270 W
 - [R-S500]
 - [Asia model] 170 W
 - [Other models] 190 W
- Standby power consumption 0.5 W or less
- YID-W10 standby power consumption
 - (YID-W10 connect) 1.2 W or less
- iPod charge power consumption
 - [R-S700] 40 W or less
 - [R-S500] 35 W or less
- Maximum power consumption [Central/South America models only]
 - [R-S700] (6 Ω, 1 kHz, 10% THD) 570 W
 - [R-S500] (8 Ω, 1 kHz, 10% THD) 380 W
- Dimensions (W x H x D) 435 × 151 × 387 mm (17-1/8" × 6" × 15-1/4")
- Weight
 - [R-S700] 11.2 kg (24.7 lbs)
 - [R-S500] 10.2 kg (22.5 lbs)

* Specifications are subject to change without notice.

LIST OF REMOTE CONTROL CODES

		Autovox	0171, 0282, 0337, 0339, 0342	Coby	0197	Electa	0348
TV		Aventura	0051	Colortyme	0008, 0026	ELECTRO TECH	0343
A.R. Systems	0320	Awa	0277, 0282	Commercial Solutions	0021	Electroband	0055, 0107
Acme	0342	Axion	0156			Electrograph	0176
Acura	0323, 0343	Baird	0282	Concerto	0008, 0026	Electrohome	0008, 0026, 0052, 0055
ADC	0337	Bang & Olufsen	0180, 0339	Concorde	0323, 0343	Element	0230
Admiral	0054, 0178, 0336, 0337, 0339, 0346, 0347	Basic Line	0282, 0320, 0323, 0340, 0343, 0350	Condor	0161, 0277, 0320, 0323, 0342, 0350, 0351	Elin	0277, 0320, 0323, 0342, 0349, 0350
Advent	0158	Bastide	0282, 0342	Contec	0179, 0277, 0323, 0342, 0343, 0344	Elite	0320, 0340, 0350
Adventura	0057	Baur	0320, 0349	Contec/Cony	0012, 0058	Elman	0341
Adyson	0277, 0282, 0342	Bazin	0282	Continental Edison		Elta	0277, 0323, 0343
Agashi	0277, 0282	Beko	0161, 0269, 0294, 0302, 0311, 0320, 0328, 0351			Emerson	0000, 0007, 0008, 0012, 0013, 0019, 0026, 0031, 0037, 0051, 0058, 0059, 0161, 0179, 0320, 0339
Agazi	0337	Belcor	0008	Cosmel	0323, 0343		
Aiko	0277, 0282, 0320, 0323, 0342, 0343	Bell & Howell	0019, 0054	Craig	0058, 0179		
Aim	0320	Benq	0097, 0242, 0361	Crosley	0010, 0037, 0171, 0339	Emprex	0154
Aiwa	0078, 0379	Beon	0320, 0349, 0350	Crown	0058, 0161, 0171, 0179, 0320, 0323, 0343, 0349, 0350, 0351	Envision	0008, 0026, 0050
Akai	0050, 0055, 0109, 0159, 0181, 0277, 0282, 0320, 0323, 0340, 0343, 0349, 0350	Best	0161			Epson	0155, 0206, 0359
Akiba	0320, 0340	Bestar	0161, 0320, 0350			Erres	0320, 0349, 0350
Akura	0320, 0323, 0337, 0340	Binatone	0282, 0342	CS Electronics	0277, 0340, 0342	ESA	0051
Alaron	0277	Blue Sky	0320, 0340	CTC Clatronic	0341	ESC	0282
Alba	0161, 0277, 0320, 0323, 0340, 0342, 0343, 0344, 0349, 0351, 0372, 0382	Blue Star	0348	CTX	0205	Etron	0343
Albatron	0140	Boots	0282, 0342	Curtis Mathes	0007, 0008, 0010, 0019, 0021, 0026, 0049, 0050, 0178	Eurofeel	0282
Alcyon	0171	BPL	0320, 0348			Euro-Feel	0337
Alleron	0059	Bradford	0058, 0179	CXC	0058, 0179	Euroline	0349
Allorgan	0282	Brandt	0322, 0345	Cybertron	0340	Euroman	0161, 0277, 0282
Allstar	0320, 0350	Brilliant	0182	Cytron	0152	Euromann	0320, 0337, 0342, 0350
America Action	0179	Brinkmann	0320	Daewoo	0007, 0008, 0026, 0037, 0053, 0167, 0266, 0275, 0277, 0282, 0315, 0320, 0323, 0331, 0335, 0342, 0343, 0350, 0381, 0465		
AMOi	0276	Brionvega	0320, 0339, 0349, 0350			Europhon	0277, 0282, 0320, 0341, 0342, 0350
Amplivision	0161, 0282, 0321, 0342	Britannia	0277, 0282, 0342	Dainichi	0277, 0340	Expert	0321
Amstrad	0320, 0323, 0337, 0340, 0343	Brockwood	0008	Dansai	0277, 0282, 0320, 0337, 0349, 0350	Exquisit	0320
Amtron	0058	Broksonic	0109, 0179	Dantax	0161, 0349	Fenner	0323, 0343
Anam	0179, 0343	Bruns	0339	Dawa	0320	Ferguson	0322, 0345, 0349
Anam National	0052, 0058	BTC	0340	Daytron	0007, 0008, 0026, 0323, 0343	Fidelity	0277, 0320, 0342, 0346
Anglo	0323, 0343	Bush	0269, 0282, 0283, 0304, 0320, 0323, 0328, 0332, 0340, 0343, 0344, 0346, 0348, 0349, 0350, 0372, 0382, 0463, 0470, 0472			Filsai	0282
Anitech	0171, 0320, 0323, 0337, 0343	Capsonic	0337			Finlandia	0346
Ansonic	0161, 0168, 0320, 0323, 0341, 0343	Carena	0320	Dantax	0161, 0349	Finlux	0171, 0282, 0320, 0339, 0341, 0342, 0349, 0350
AOC	0008, 0026, 0050, 0053	Carnivale	0050	Dawoo	0007, 0008, 0026, 0323, 0343	FIRST LINE	0342, 0343, 0350
Apex	0039, 0111, 0217	Carrefour	0344	De Graaf	0346	Firstline	0277, 0282, 0320, 0323
Arcam	0277, 0282	Carver	0010	Decca	0282, 0320, 0342, 0349, 0350	Fisher	0019, 0161, 0282, 0339, 0342, 0344, 0351
Arcam Delta	0342	Cascade	0320, 0323, 0343	Dell	0145, 0245	Flint	0320, 0350
Aristona	0320, 0349, 0350	Casio	0367	Denver	0358, 0362	Formenti	0171, 0277, 0336, 0339, 0342, 0349
Arthur Martin	0321	Cathay	0320, 0349, 0350	Desmet	0320, 0349, 0350	Formenti/Phoenix	0277
ASA	0339, 0347	CCE	0183, 0282	Diamant	0320	Fortress	0336, 0339
Asberg	0171, 0320, 0350	Celebrity	0055, 0107	Diamond	0277	Fraba	0161, 0320
Astra	0343	Celera	0039	DiamondVision	0135, 0143	Friac	0161
Asuka	0277, 0282, 0337, 0340, 0342	Centurion	0320, 0349, 0350	Dimensia	0049	Frontech	0282, 0323, 0337, 0343, 0346, 0347
Atlantic	0277, 0320, 0342, 0349, 0350	Century	0339	Disney	0219	Fujitsu	0059, 0069, 0074, 0075, 0282
Atori	0323, 0343	Century	0339	Dixi	0282, 0320, 0323, 0343, 0349, 0350	Fujitsu General	0282
Auchan	0321	CGE	0161, 0171	Dream Vision	0461, 0498	Fujitsu Siemens	0504, 0505, 0507, 0510, 0511
Audiosonic	0161, 0282, 0320, 0340, 0342, 0343, 0349, 0350	Changhong	0039	DTS	0323, 0343	Funai	0051, 0058, 0059, 0112, 0113, 0115, 0118, 0119, 0179, 0337
AudioTon	0161, 0282, 0342	Chimei	0273	Dual	0282, 0320, 0342		
Audiovox	0058, 0179, 0194	Cimline	0323, 0343	Dual-Tec	0342, 0343		
Ausind	0171	Citizen	0007, 0008, 0026, 0050, 0058	Dumont	0008, 0030, 0062, 0282, 0339, 0341, 0342		
		City	0323, 0343	Durabrand	0031, 0051, 0179, 0215		
		Clarion	0179				
		Clarivox	0349	Dux	0349		
		Clatronic	0161, 0171, 0282, 0320, 0323, 0337, 0340, 0342, 0343, 0350, 0351	Dwin	0178	Futuretech	0058, 0179
		CMS	0277	Dynatron	0320, 0349, 0350	Galaxi	0320, 0351
		CMS Hightec	0282	Dynex	0228, 0231	Galaxis	0161, 0320
				Elbe	0161, 0168, 0282, 0320	Gateway	0176, 0177, 0241
				Elcit	0339	GBC	0323, 0343, 0344

GE	0008, 0021, 0023, 0026, 0027, 0031, 0034, 0049, 0052, 0056, 0209	Hitachi	0008, 0012, 0026, 0066, 0084, 0092, 0093, 0120, 0172, 0173, 0255, 0270, 0271, 0282, 0320, 0335, 0338, 0342, 0344, 0346, 0347, 0365, 0382, 0448, 0456, 0467	Kapsch Karcher Kawasho KEC Kendo Kenwood KIC Kingsley KLH Kloss Novabeam Kneissel Kolster Konka Korpel Korting Kosmos Koyoda KTV Kyoto Lasat Lenco Lenoir Leyco LG	0347 0161, 0320, 0342, 0343, 0349 0008, 0026, 0055, 0277 0179 0161, 0320, 0341, 0346 0008, 0026, 0050 0282 0277, 0342 0039 0057, 0058 0161, 0168, 0320 0320, 0350 0340 0320, 0349, 0350 0161, 0339 0320 0343 0007, 0050, 0058, 0179, 0183, 0282, 0342 0277, 0282 0161 0323, 0343 0323, 0342, 0343 0320, 0337, 0349, 0350 0031, 0053, 0066, 0116, 0117, 0140, 0161, 0164, 0175, 0195, 0269, 0277, 0282, 0300, 0309, 0317, 0320, 0323, 0328, 0342, 0343, 0346, 0349, 0350, 0366, 0368, 0377, 0466, 0471, 0478	Manesth Marantz Marelli Mark Masuda Matsui Matsushita Maxent Mediator Medion Megapower Megatron MElectronic Melvox Memorex Memphis Mercury Metz MGA Micromaxx Microstar Midland Minerva Minoka Mintek Mitsubishi	0282, 0320, 0337, 0342, 0349, 0350 0008, 0010, 0026, 0050, 0204, 0320, 0349, 0350 0339 0277, 0282, 0320, 0323, 0349, 0350 0282 0282, 0320, 0323, 0342, 0343, 0344, 0346, 0349, 0350, 0455 0017 0147, 0176 0320, 0349, 0350 0320, 0337, 0343 0140 0026, 0031 0277, 0282, 0320, 0323 0321 0019, 0026, 0031, 0053, 0054, 0137, 0215, 0323, 0343 0323, 0343 0320, 0323 0339 0008, 0026, 0031, 0050, 0053 0337, 0343 0337, 0343 0007, 0021, 0023, 0027, 0030, 0056, 0062 0171 0320, 0350 0008, 0026, 0031, 0053, 0066, 0084, 0093, 0098, 0150, 0178, 0289, 0320, 0339, 0344, 0350, 0376 0161, 0168, 0171, 0277, 0282, 0342 0140 0054 0171 0052, 0178 0008, 0026, 0050, 0053, 0161, 0277 0058, 0161, 0179, 0183, 0277, 0282, 0320, 0323, 0341, 0342, 0343, 0344, 0346, 0349 0277, 0342 0026, 0031, 0111 0346 0008, 0026, 0050, 0052, 0053, 0072, 0103, 0282, 0344, 0161, 0282, 0320, 0339, 0342, 0346, 0349, 0351 0320, 0349, 0350 0176 0320, 0323 0343, 0350 0340 0282, 0320, 0323 0277, 0342
Geant Casino	0321						
GEC	0282, 0320, 0342, 0347, 0349, 0350						
Geloso	0323, 0343, 0346						
General Technic	0323, 0343						
Genexxa	0320, 0340, 0347, 0350	Hornymphon Hoshai	0320, 0350 0340				
GFM	0128, 0227	Huanayu	0277, 0342				
Giant	0282	Hygashi	0277, 0282, 0342				
Gibraltar	0008, 0030, 0050, 0062	Hyper	0277, 0282, 0323, 0342, 0343				
GoldHand	0277	Hypson	0282, 0320, 0321, 0337, 0342, 0348, 0349, 0350				
Goldline	0320						
GoldStar	0007, 0008, 0012, 0026, 0031, 0050, 0053, 0161, 0277, 0282, 0320, 0323, 0342, 0343, 0346, 0349, 0350	Hyundai Iberia ICE	0141 0320 0277, 0282, 0320, 0323, 0337, 0340, 0342, 0343, 0350 0277				
Goodmans	0246, 0272, 0282, 0320, 0323, 0337, 0343, 0344, 0349, 0350, 0462, 0473, 0477	ICeS Ilo IMA Imperial	0148, 0153 0058 0161, 0171, 0320, 0347, 0350, 0351 0320, 0349, 0350 0010				
Gorenje	0161, 0351	Indiana	0320, 0349, 0350				
GPM	0340	Infinity	0010				
GPX	0129	InFocus	0250, 0327, 0363, 0479, 0508				
Gradiente	0240						
Graetz	0347	Ingelen	0347				
Granada	0171, 0282, 0320, 0321, 0342, 0344, 0346, 0349, 0350	Ingersol Initial Inno Hit	0323, 0343 0153 0171, 0282, 0320, 0323, 0340, 0342, 0343, 0349, 0350 0337, 0343				
Grandin	0340, 0343, 0348, 0349						
Gronic	0282	Innovation	0337, 0343				
Grundig	0160, 0161, 0171, 0310, 0320	Insignia	0131, 0228, 0236, 0238	LG/GoldStar Liesenk Liesenkotter	0164 0349 0320		
Grunpy	0058, 0059, 0179	Inteq	0030	Life	0337, 0343		
Haier	0157, 0233	Interactive	0161	Lifetec	0320, 0323, 0337, 0343		
Halifax	0277, 0282, 0337, 0342	Interbuy Interfunk	0323, 0343 0161, 0320, 0339, 0347, 0349, 0350	Lloyds Loewe	0323 0161, 0168, 0265, 0320, 0330, 0352		
Hallmark	0008, 0026, 0031	International	0277	Loewe Opta	0339, 0349, 0350		
Hampton	0277, 0282, 0342	Intervision	0161, 0282, 0320, 0337, 0341, 0342	Logik Luma	0054 0320, 0323, 0346, 0349		
Hanseatic	0161, 0168, 0282, 0320, 0323, 0342, 0343, 0344, 0349, 0350	Irradio	0171, 0320, 0323, 0340, 0343, 0349, 0350	Lumatron	0282, 0320, 0346, 0349, 0350		
Hantarex	0320, 0323, 0343			Lux May	0350		
Hantor	0320	Isukai	0320, 0340	Luxman	0008, 0026		
Harman/Kardon	0010	ITC	0282, 0342	Luxor	0282, 0342, 0346		
Harvard	0058, 0179	ITS	0277, 0320, 0340, 0348, 0350	LXI	0010, 0019, 0021, 0026, 0027, 0031, 0049, 0111		
Harwood	0320, 0323	ITT	0343, 0347	M Electronic	0342, 0343, 0345, 0347, 0349, 0350		
Havermy	0178	ITV	0320, 0343, 0349	MAG	0096		
HCM	0282, 0320, 0323, 0337, 0342, 0343, 0348	Janeil JBL	0057 0010	Magnadyne Magnafon	0339, 0341, 0349 0171, 0277, 0341, 0342		
Hema	0282, 0323	JC Penney	0007, 0008, 0026, 0027, 0049, 0053, 0056	Magnavox	0008, 0009, 0010, 0013, 0026, 0032, 0033, 0048, 0050, 0128, 0211, 0212, 0224, 0226, 0239		
Hewlett Packard	0192			Magnum	0337, 0343		
Higashi	0277	JCB	0055, 0107	Majestic	0054		
HiLine	0320	Jensen	0008, 0026	Mandor	0337		
Hinari	0320, 0323, 0340, 0343, 0344, 0349, 0350	JVC	0012, 0014, 0015, 0056, 0064, 0065, 0067, 0169, 0174, 0297, 0314, 0344, 0350, 0375				
Hisawa	0321, 0340, 0348						
Hisense	0247	Kaisui	0277, 0282, 0320, 0323, 0340, 0342, 0343, 0348				
		Kamosonic	0342				
		Kamp	0277, 0342				

Nikkai	0277, 0282, 0320, 0323, 0337, 0340, 0342, 0349, 0350	Philips	0008, 0009, 0010, 0011, 0012, 0032, 0048, 0049, 0052, 0122, 0128, 0134, 0186, 0187, 0213, 0221, 0224, 0226, 0239, 0256, 0257, 0259, 0261, 0263, 0267, 0280, 0281, 0287, 0296, 0299, 0301, 0303, 0305, 0313, 0319, 0320, 0324, 0333, 0339, 0342, 0349, 0350, 0353, 0357, 0360, 0380, 0383, 0452, 0459, 0460	Radiotone	0161, 0320, 0323, 0350	SEG	0277, 0282, 0320, 0323, 0337, 0341, 0342, 0344, 0349, 0382
Nikko	0026, 0031, 0050			Rank	0344		
Nobliko	0171, 0277, 0341, 0342			RCA	0008, 0021, 0024, 0025, 0026, 0027, 0042, 0049, 0052, 0053, 0063, 0136, 0225	SEI	0320
Nokia	0347					SEI-Sinudyne	0339, 0341, 0347
Norcent	0201					Seleco	0344, 0346, 0347
Nordic	0282			Realistic	0019, 0031, 0050, 0179	Sencora	0323, 0343
Nordmende	0339, 0345, 0347, 0350			Recor	0320	Sentra	0323
Nordvision	0349			Redstar	0320	Serino	0277
Novatronic	0320			Reflex	0320	Sharp	0000, 0001, 0002, 0003, 0007, 0008, 0012, 0026, 0060, 0088, 0089, 0091, 0138, 0165, 0170, 0178, 0198, 0229, 0262, 0278, 0279, 0291, 0308, 0312, 0336, 0344, 0354, 0370, 0449, 0450, 0451, 0464, 0474, 0476
Oceanic	0321, 0347			Revovox	0161, 0320, 0349, 0350		
Okano	0161, 0320, 0351			Rex	0337, 0346, 0347		
Olevia	0102, 0199, 0200, 0207, 0222			RFT	0161, 0168, 0339		
ONCEAS	0342	Philips Magnavox	0011, 0032, 0033	Rhapsody	0277		
Onwa	0058, 0179	Phoenix	0161, 0277, 0320, 0339, 0349, 0350	R-Line	0320, 0349, 0350	Sheng Chia	0178
Opera	0320			Roadstar	0323, 0337, 0340, 0343	Shogun	0008
Oppo	0130	Phonola	0277, 0320, 0339, 0349, 0350	Robotron	0339	Siarem	0320, 0339, 0341
Optimus	0017, 0019			Rowa	0277, 0282	Sierra	0320, 0350
Optoma	0144	Pilot	0007, 0008, 0050	Royal Lux	0161	Siesta	0161
Optonica	0178	Pioneer	0008, 0026, 0094, 0095, 0161, 0320, 0345, 0347, 0349, 0350, 0458	RTF	0339	Signature	0054
Orbit	0320, 0350			Runco	0030, 0050, 0062	Silva	0277
Orion	0043, 0146, 0283, 0320, 0323, 0328, 0343, 0349, 0350	Plantron	0320, 0323, 0337, 0350	Saba	0298, 0322, 0339, 0345, 0347	Silver	0344
Orline	0320			Saisho	0282, 0323, 0337, 0342, 0343	Singer	0321, 0339, 0341
Osaki	0282, 0320, 0337, 0340, 0342	Playsonic	0282	Salora	0346, 0347	Sinudyne	0320, 0339, 0341, 0349
Oso	0340	Polaroid	0039, 0142, 0202, 0234	Sambers	0171, 0341	Skantic	0347
Otto Versand	0282, 0320, 0336, 0342, 0344, 0348, 0349, 0350	Poppy	0323, 0343	Sampo	0007, 0008, 0026, 0050, 0176	Solavox	0347
Pael	0277, 0342	Portland	0007, 0008, 0026, 0053	Samsung	0004, 0005, 0006, 0007, 0008, 0012, 0026, 0031, 0036, 0050, 0053, 0076, 0077, 0079, 0114, 0124, 0125, 0126, 0127, 0139, 0161, 0183, 0185, 0190, 0191, 0258, 0264, 0277, 0282, 0320, 0323, 0334, 0337, 0342, 0343, 0349, 0350, 0351, 0373, 0453, 0468	Sonolor	0321, 0347
Palladium	0161, 0282, 0320, 0342, 0351	Prandoni-Prince	0171, 0346	Sandra	0277, 0282, 0342	Sontec	0161, 0320, 0349, 0350
Palsonic	0282	Precision	0282, 0342	Sansui	0043, 0109, 0320, 0350	Sound & Vision	0340, 0341
Panama	0277, 0282, 0320, 0323, 0337, 0342, 0343	Prima	0157, 0243, 0323, 0343, 0347	Sanyo	0008, 0019, 0068, 0070, 0071, 0099, 0161, 0168, 0223, 0237, 0277, 0282, 0288, 0295, 0323, 0342, 0344, 0369, 0469	Soundesign	0008, 0026, 0031, 0058, 0059, 0179
Panasonic	0016, 0017, 0020, 0022, 0023, 0035, 0052, 0056, 0084, 0085, 0133, 0163, 0193, 0284, 0286, 0290, 0292, 0320, 0325, 0347, 0356	Princeton	0140	Schaub Lorenz	0347	Soundwave	0320, 0349, 0350
Panavigation	0320	Prism	0023, 0056	Schneider	0282, 0316, 0318, 0320, 0333, 0340, 0342, 0349, 0350, 0382	Squareview	0051
Pathe Cinema	0161, 0168, 0277, 0321, 0342	Profex	0323, 0343	Scotch	0026, 0031	SSS	0008, 0058, 0179
Pausa	0323, 0343	Profi-Tronic	0320, 0350	Scott	0008, 0012, 0026, 0031, 0058, 0059, 0149, 0179	Standard	0282, 0320, 0323, 0340, 0342, 0343, 0350
Penney	0021, 0023, 0031, 0050, 0111	Proline	0320, 0350	Sceptre	0235, 0244	Starlite	0058, 0179, 0320, 0323, 0349
Perdio	0277, 0320	Proscan	0021, 0027, 0049	Schaub Lorenz	0347	Stenway	0348
Perfekt	0320	Prosonic	0161, 0277, 0282, 0320, 0342, 0349	Schneider	0282, 0316, 0318, 0320, 0333, 0340, 0342, 0349, 0350, 0382	Stern	0346, 0347
Philco	0008, 0009, 0010, 0012, 0026, 0050, 0052, 0053, 0161, 0171, 0320, 0339	Protech	0282, 0337, 0341, 0342, 0343, 0349, 0350	Schneider	0282, 0316, 0318, 0320, 0333, 0340, 0342, 0349, 0350, 0382	Strato	0320, 0323
		Proton	0008, 0012, 0026, 0031	Schneider	0282, 0316, 0318, 0320, 0333, 0340, 0342, 0349, 0350, 0382	Stylandia	0282
		Protron	0196	Schneider	0282, 0316, 0318, 0320, 0333, 0340, 0342, 0349, 0350, 0382	Sunkai	0343
		PROVIEW	0096, 0246	Schneider	0282, 0316, 0318, 0320, 0333, 0340, 0342, 0349, 0350, 0382	Sunstar	0320, 0323
		Provision	0320, 0349	Schneider	0282, 0316, 0318, 0320, 0333, 0340, 0342, 0349, 0350, 0382	Sunwood	0320, 0323, 0343, 0350
		Pulsar	0008, 0030, 0062	Schneider	0282, 0316, 0318, 0320, 0333, 0340, 0342, 0349, 0350, 0382	Superla	0277, 0282, 0342
		Pye	0256, 0320, 0349, 0350, 0378	Schneider	0282, 0316, 0318, 0320, 0333, 0340, 0342, 0349, 0350, 0382	Superscan	0013, 0178
		Pymi	0323, 0343	Schneider	0282, 0316, 0318, 0320, 0333, 0340, 0342, 0349, 0350, 0382	SuperTech	0277, 0320, 0323
		Quandra Vision	0321	Schneider	0282, 0316, 0318, 0320, 0333, 0340, 0342, 0349, 0350, 0382	Supra	0323, 0343
		Quasar	0017, 0023, 0052, 0056	Schneider	0282, 0316, 0318, 0320, 0333, 0340, 0342, 0349, 0350, 0382	Supre-Macy	0057
		Quelle	0282, 0320, 0337, 0342, 0349, 0350	Schneider	0282, 0316, 0318, 0320, 0333, 0340, 0342, 0349, 0350, 0382	Supreme	0055, 0107
		Questa	0344	Schneider	0282, 0316, 0318, 0320, 0333, 0340, 0342, 0349, 0350, 0382		
		Radialva	0320	Schneider	0282, 0316, 0318, 0320, 0333, 0340, 0342, 0349, 0350, 0382		
		RadioShack	0019, 0021, 0031, 0050, 0179, 0320	Schneider	0282, 0316, 0318, 0320, 0333, 0340, 0342, 0349, 0350, 0382		
		RadioShack/Realistic	0007, 0008, 0012, 0026, 0049, 0058	Schneider	0282, 0316, 0318, 0320, 0333, 0340, 0342, 0349, 0350, 0382		
		Radiola	0282, 0320, 0349, 0350	Schneider	0282, 0316, 0318, 0320, 0333, 0340, 0342, 0349, 0350, 0382		
		Radiomarelli	0320, 0339	Schneider	0282, 0316, 0318, 0320, 0333, 0340, 0342, 0349, 0350, 0382		

Hughes	1111, 1113, 1122	Migros	1026	Realistic	1065, 1068, 1069,	Teac	1009, 1069
Hughes Network Systems	1110, 1116	Mind	1016		1070, 1071	Tec	1008, 1009, 1030
	Humax	Mitsubishi	1026, 1028, 1079	ReplayTV	1022, 1123	Technics	1068
	1012, 1110, 1113	Motorola	1068	Rex	1027	Teknika	1068, 1069, 1071
	Hush	MTC	1070	RFT	1008, 1028, 1030	Teleavia	1027
	Hypson	Multitech	1008, 1026, 1028,	Ricavision	1016	Telefunken	1027
	1029		1029, 1030, 1069,	Roadstar	1008, 1009, 1025,	Teletex	1008, 1009
	iBUYPOWER		1070		1029, 1031	Tenosal	1008, 1029
	1016	Murphy	1026	Royal	1008	Tensai	1008, 1026, 1029,
	Impego	NEC	1027, 1064, 1065	Runco	1114		1031
	1030	Neckermann	1027, 1028	Saba	1027	Tevion	1024
	Imperial	NEI	1028	Saisho	1024, 1029	Thomson	1005, 1027
	Inno Hit	Nesco	1008, 1029	Samsung	1002, 1034, 1041,	Thorn	1027
	1008, 1009, 1025,	Nikkai	1008, 1009, 1030		1043, 1057, 1060,	Tivo	1108, 1110, 1111,
	1028, 1029, 1030	Nikko	1071		1070, 1084, 1110,		1113, 1117, 1118,
	Innovation	Niveus Media	1016		1116, 1122, 1124,		1119, 1122
	1024	Noblex	1070		1220, 1222	TMK	1070
	Instant Replay	Nokia	1009, 1027	Samurai	1008, 1030	Tokai	1008, 1029, 1031
	1068	Nordmende	1027	Sanky	1114	Tonsai	1029
	Interbuy	Northgate	1016	Sansui	1023, 1027, 1106,	Toshiba	1004, 1016, 1027,
	1008, 1031	Oceanic	1026, 1027		1115		1028, 1037, 1049,
	Interfunk	Okano	1008, 1009, 1024	Sanyo	1032, 1065, 1070		1052, 1086, 1087,
	1028	Olympus	1068	Saville	1009		1097, 1109, 1112,
	Intervision	Optimus	1071	SBR	1028		1194
	1009, 1026	Orion	1023, 1024, 1051,	Schaub Lorenz	1026, 1027	Totevision	1070, 1071
	Irradio		1115, 1217	Schneider	1008, 1009, 1024,	Touch	1016
	1008, 1029, 1031	Orson	1026		1025, 1026, 1028,	Towada	1008, 1029
	ITT	Osaki	1008, 1026, 1029,		1029, 1030, 1031	Towika	1008, 1029
	1027		1031	Sears	1065, 1068, 1071	TVA	1030
	ITV	Otto Versand	1028	SEG	1008, 1009, 1029	Uher	1031
	1009, 1025, 1031	Palladium	1008, 1027, 1029,	SEI-Sinudyne	1028	UltimateTV	1019
	JC Penney		1031	Seleco	1027	Ultravox	1009
	1064, 1065, 1068,	Panasonic	1000, 1022, 1044,	Sentra	1008, 1030	Unitech	1070
	1070, 1071		1055, 1068, 1072,	Sentron	1008, 1029	United Quick Star	1009, 1025
	JCL		1085, 1090, 1091,	Sharp	1003, 1033, 1077,	Universum	1026, 1028, 1031
	1068		1120, 1121, 1214		1107, 1127, 1219	Vector Research	1064
	JVC	Pathe Marconi	1027	Shintom	1008, 1029	Video Concepts	1064
	1007, 1018, 1027,	Perdio	1026	Shivaki	1031	Videon	1024
	1039, 1064, 1065,	Philco	1008, 1068	Shogun	1070	Videosonic	1070
	1066, 1067, 1078,	Philips	1006, 1013, 1028,	Siemens	1031	Viewsonic	1016
	1089, 1092, 1093,		1035, 1040, 1045,	Silva	1031	Voodoo	1016
	1094, 1095, 1113,		1046, 1050, 1058,	Silver	1009	Wards	1068, 1069, 1070,
	1208, 1209, 1212,		1059, 1061, 1068,	Singer	1068		1071
	1213, 1215, 1218		1076, 1101, 1110,	Sinudyne	1028	Weltblick	1031
	Kaisui		1113, 1116, 1117,	Solavox	1030	XR-1000	1068, 1069
	1008, 1029		1122, 1126, 1210,	Sonic Blue	1022, 1123	Yamaha	1064, 1065
	Karcher	Philips Magnavox	1076	Sonneclair	1008	Yamishi	1008, 1029
	1028	Phonola	1028	Sonoko	1009, 1025	Yokan	1008, 1029
	Kendo	Pilot	1071	Sontec	1031	Yoko	1008, 1029, 1030,
	1008, 1024, 1025,	Pioneer	1028, 1036	Sony	1001, 1016, 1048,		1031
	1030	Polaroid	1088, 1099		1053, 1073, 1074,	Zenith	1114
	Kenwood	Portland	1009, 1025, 1030		1080, 1081, 1082,	ZT Group	1016
	1027, 1064, 1065	Prinz	1026	Stack	1083, 1108, 1118,		
	Kodak	Profex	1029	Stack 9	1216		
	1068, 1071	Proline	1026	Standard	1016	DVD player	
	Korpel	Proscan	1019	Stern	1009, 1025	4Kus 2051	
	1008, 1029	Prosonic	1009, 1024	STS	1009	Accurian	2142
	Kyoto	Pulsar	1114	Sunkai	1068	Advent	2155, 2251
	1008	Pye	1028, 1102	Sunstar	1024	AEG	2362
	Lenco	Quarter	1065	Suntronic	1026	Airis	2364
	1025	Quartz	1065	Sunwood	1026	Aiwa	2322
	Leyco	Quasar	1068	Superscan	1008, 1029	Akai	2145, 2177, 2179,
	1008, 1029	Quelle	1026, 1028	Sylvania	1020		2248
	LG	Radialva	1008		1020, 1068, 1069,	Akura	2356
	1010, 1026, 1031,	RadioShack	1071		1102, 1126	Alba	2064, 2165, 2186,
	1047, 1054, 1056,	RadioShack/Realistic	1065, 1068, 1069,	Symphonic	1008, 1069, 1126	Alco	2337, 2346
	1071, 1103, 1221		1070, 1071	Systemax	1016	Alize	2361
	Lifetec			Tagar Systems	1016	Allegro	2133
	1024	Radiola	1028	Taisho	1024	Amitech	2362
	Lifetec	Radix	1071	Tandberg	1009	Amphion MediaWorks	
	1016	Randex	1071	Tandy	1065		2195
	Linksys	RCA	1019, 1068, 1070,	Tashiko	1026, 1071	AMW	2195, 2363
	1069		1075, 1110, 1113,	Tatung	1026, 1027, 1028		
	Lloyd's		1122, 1125	TCM	1015, 1024, 1042		
	1069						
	Loewe Opta						
	1028, 1031						
	Logik						
	1008, 1029						
	Lumatron						
	1009, 1025						
	Luxor						
	1008						
	LXI						
	1071						
	M Electronic						
	1026						
	Magnavox						
	1020, 1068, 1114,						
	1126						
	Magnin						
	1071						
	Manesth						
	1008, 1029						
	Marantz						
	1028, 1064, 1065,						
	1068						
	Mark						
	1009						
	Marta						
	1071						
	Matsui						
	1024, 1031						
	Matsushita						
	1068						
	Media Center PC						
	1016						
	Mediator						
	1028						
	Medion						
	1024						
	MEI						
	1068						
	Memorex						
	1023, 1026, 1031,						
	1065, 1068, 1069,						
	1070, 1071, 1098,						
	1114						
	Memphis						
	1008, 1029						
	MGN Technology						
	1070						
	Micromaxx						
	1024						
	Microsoft						
	1016						
	Microstar						
	1024						

Apex	2030, 2124, 2125, 2126, 2127, 2130, 2131	Easy Home	2359	KXD	2359	peekTON	2364
		Eclipse	2354	Landel	2143	Philips	2008, 2012, 2025, 2044, 2050, 2051, 2053, 2060, 2072, 2108, 2111, 2147, 2159, 2163, 2169, 2174, 2181, 2185, 2230, 2261, 2266, 2267, 2286, 2287, 2289, 2295, 2300, 2302, 2317, 2328, 2338, 2342, 2350, 2467
Apple	2241	E-Dem	2364	Lasonic	2132		
Arrgo	2138	Electrohome	2362	Lawson	2355	Phonotrend	2367
Asono	2364	Elin	2362	Lecson	2381	Pioneer	2016, 2017, 2018, 2019, 2035, 2092, 2094, 2095, 2109, 2157, 2180, 2190, 2212, 2269, 2272, 2299, 2304, 2305, 2306, 2307, 2308, 2309, 2310, 2311, 2344, 2345, 2347, 2379
Aspire	2152, 2222	Elta	2341, 2361, 2362	Lenco	2358, 2362, 2367		
Astar	2240	Emerson	2129, 2137, 2150	Lenoxx	2136, 2153		
ATACOM	2364	Enterprise	2129	LG	2002, 2033, 2038, 2057, 2129, 2133, 2189, 2191, 2223, 2238, 2270, 2288, 2335, 2373, 2375		
Audiovox	2061, 2149	Enzer	2380				
Avious	2367	Epson	2247	Life	2182		
Awa	2363	ESA	2137	Lifetec	2182		
Axion	2249	Finlux	2354, 2362, 2367	Limit	2355		
Bang & Olufsen	2128	Fintec	2377	Liquid Video	2158		
Baze	2367	Fisher	2134	Liteon	2043, 2051, 2142		
BBK	2364	Funai	2137	Loewe	2320		
Bellagio	2363	Gateway	2051	LogicLab	2355		
Best Buy	2359	GE	2029, 2131, 2156	Magnavox	2025, 2050, 2137, 2150, 2159, 2224, 2230, 2358		
Blaupunkt	2131	Gericom	2351				
Blue Parade	2157	GFM	2226				
Boghe	2382	Giec	2382				
Brainwave	2362	Global Solutions	2355				
Brandt	2148, 2188	Global Sphere	2355				
Broksonic	2145, 2146	Go Video	2133, 2213	Magnex	2367		
Bush	2064, 2110, 2170, 2268, 2290, 2346, 2358, 2367, 2383	Goodmans	2165, 2280, 2291, 2358, 2371, 2376, 2382	Majestic	2360		
				Marantz	2328	Pointer	2362
				Marquant	2362	Polaroid	2125, 2215, 2235
California Audio Labs		GPX	2227	Matsui	2148, 2378	Portland	2362
		Gradiente	2151	McIntosh	2199	Powerpoint	2363
Cambridge Audio	2354	Graetz	2380	Mecotek	2362	Prima	2252
CAT	2352, 2353	Greenhill	2131	Medion	2182	Proceed	2130
CAVS	2192	Grundig	2349	Memorex	2028, 2145, 2234	Proscan	2156
Centrum	2353	Grunkel	2362, 2366	MiCO	2354, 2382	Prosonic	2360, 2377
CGV	2354, 2362	GVG	2377	Micromaxx	2182	Protron	2202
Changhong	2140	H&B	2358	Microsoft	2156	Provision	2358
Cinetec	2363	H_her	2364	Microstar	2182	Pye	2144
CineVision	2133, 2237	Haaz	2354, 2355	Minoka	2362	Qwestar	2148
Clatronic	2358, 2367	Haier	2254	Minowa	2367	Raite	2380
Coby	2031, 2046, 2360	Harman/Kardon	2047, 2135	Mintek	2131, 2245	RCA	2021, 2029, 2104, 2105, 2131, 2149, 2156, 2157, 2229
Conia	2383	HiMAX	2359	Mitsubishi	2003		
Continental Edison		Hitachi	2062, 2090, 2115, 2274, 2282, 2316, 2359, 2380	Mizuda	2358, 2359	RedStar	2356, 2360, 2362
				Monyka	2380	Regent	2153
Crown	2362	Hiteker	2130	Mustek	2186	Reoc	2355
C-Tech	2355	Home Tech Industries		Mx Onda	2354	Rimax	2361
Curtis Mathes	2139			Mystral	2366	Rio	2133
CVG	2377	Hyundai	2366	Naiko	2362	Roadstar	2331, 2358
CyberHome	2022, 2098, 2138, 2187, 2336	Ilo	2245	Nesa	2131	Ronin	2363
		Initial	2131, 2245	Neufunk	2380	Rotel	2203
Cytron	2244	Innovation	2182	Nevir	2362	Rowa	2154, 2383
Daenyx	2363	Integra	2002, 2137, 2253	Next Base	2143	Rowsonic	2353
Daewoo	2001, 2133, 2276, 2298, 2330, 2362, 2363, 2377	Irradio	2157	Nexstech	2243	Saba	2148, 2188
		iSymphony	2246	NU-TEC	2383	Sabaki	2355
Daewoo International		JBL	2135	Onkyo	2159, 2368	Saivod	2362
		JVC	2020, 2096, 2097, 2099, 2100, 2101, 2102, 2103, 2106, 2107, 2160, 2257, 2260, 2262, 2263, 2321, 2324, 2326, 2327, 2343, 2464, 2465, 2468, 2469, 2471	Oopla	2051	Sampo	2141
Dalton	2357			Optim	2196, 2255	Samsung	2000, 2045, 2077, 2112, 2113, 2114, 2115, 2151, 2200, 2216, 2219, 2228, 2264, 2265, 2271, 2279, 2294, 2303, 2329, 2365
Dansai	2362, 2381	Kansai	2360	Optimus	2180		
Daytek	2184, 2195, 2363	Kawasaki	2149	Orava	2358	Sansui	2073, 2145, 2354, 2355, 2362
Dayton	2363	Kennex	2362	Orbit	2363	Sanyo	2134, 2145, 2217, 2292
DEC	2358	Kenwood	2041, 2151, 2348	Orion	2073, 2110	ScanMagic	2186
Decca	2362	KeyPlug	2362	Oritron	2148, 2158	Schaub Lorenz	2362
Denon	2059, 2151, 2193, 2332	Kiiro	2362	P&B	2358	Schneider	2176
		Kingavon	2358	Pacific	2355	Scientific Labs	2355
Denver	2356, 2358, 2360, 2370	Kiss	2380	Panasonic	2011, 2024, 2034, 2042, 2058, 2062, 2066, 2067, 2093, 2116, 2117, 2118, 2119, 2120, 2121, 2122, 2123, 2151, 2159, 2164, 2166, 2167, 2172, 2173, 2175, 2209, 2214, 2275, 2277, 2278, 2281, 2282, 2283, 2301, 2374, 2470	Scott	2161, 2357
Denzel	2380	KLH	2131, 2149			Seeltech	2364
Desay	2205	Koda	2358			SEG	2162, 2355, 2363, 2380
Diamond	2354, 2355	Koss	2013, 2148, 2158	Parasound	2197		
DiamondVision	2225, 2232						
Disney	2010, 2028						
DK Digital	2339						
Dmtech	2176						
Dual	2380						
Durabrand	2136						
DVX	2355						

Sharp	2006, 2040, 2088, 2091, 2182, 2194, 2220, 2221, 2231, 2236, 2293, 2340	Venturer	2149	Sanyo	2217	Jerrold	3017, 3018, 3025, 3066, 3072, 3084, 3090, 3096, 3119, 3123
Shinsonic	2245	Viewmaster	2364	Sony	2004, 2005, 2007, 2052, 2068, 2069, 2074, 2208, 2210, 2211	JVC	3099
Sigmatek	2359, 2364	Vocopro	2206	Sylvania	2239	Kabel Deutschland	3024, 3027, 3121
Silva	2356	VocoStar	2207	Toshiba	2032, 2036, 2037, 2039, 2049, 2054, 2055, 2076	Macab	3101
Singer	2354, 2355	Waitec	2364	Yamaha	2056	Magnavox	3079
Skymaster	2325, 2355	Welltech	2382			Maspro	3099
Skyworth	2356	Westinghouse	2063, 2250			Matsui	3099
Slim Art	2362	Wharfedale	2354, 2355			MegaCable	3117
SM Electronic	2355	Woxter	2361, 2364			Memorex	3076, 3122
Sonic Blue	2133	Xbox	2156, 2183			Minerva	3099
Sontech	2366	Xlogic	2355, 2362			Mnet	3107
Sony	2004, 2005, 2007, 2009, 2014, 2015, 2023, 2026, 2027, 2052, 2068, 2069, 2070, 2071, 2074, 2075, 2084, 2085, 2087, 2168, 2171, 2208, 2210, 2211, 2258, 2273, 2284, 2285, 2312, 2313, 2314, 2315, 2318, 2319, 2466	XMS	2362			Motorola	3025, 3026, 3084, 3088, 3090, 3095, 3117
Soundmaster	2355	Xoro	2382			Movie Time	3077, 3109
Soundmax	2355	Yamada	2051, 2361, 2363			Mr Zapp	3101
Spectra	2363	Yamaha	2056, 2064, 2065, 2080, 2081, 2082, 2083, 2089, 2118, 2151, 2323			Multichoice	3107
Spectroniq	2201	Yamakawa	2363, 2380			Multitech	3127
Standard	2355	Yukai	2186			NEC	3064
Star Cluster	2355	Zenith	2002, 2129, 2133, 2159, 2223			NET Brazil	3085
Starmedia	2358, 2364					Nokia	3097
Sungale	2204					Noos	3101
Sunkai	2362					NSC	3077
Superscan	2150					Oak	3074
Supervision	2355					Pace	3006, 3089, 3121
Sylvania	2012, 2137, 2150, 2178, 2230, 2239					Palladium	3099
Symphonic	2108, 2230					Panasonic	3112, 3118, 3122
Synn	2355					Paragon	3122
T.D.E. Systems	2366					Philips	3068, 3071, 3079, 3099, 3100, 3101, 3103
Tatung	2001, 2362					Pioneer	3001, 3006, 3094, 3098, 3114, 3116, 3120
TCM	2182, 2297					Popular Mechanics	3126
Teac	2149, 2333, 2355, 2383					Proscan	3066, 3093
Tec	2356					Pulsar	3122
Technics	2151					PVP Stereo Visual Matrix	3018
Technika	2362, 2367					Quasar	3122
Telefunken	2353					RadioShack	3123, 3127
Tensai	2362					RCA	3030, 3031, 3087, 3118
Tevion	2182, 2355, 2357					Realistic	3070
Theta Digital	2157					Recoton	3126
Thomson	2183, 2188, 2334, 2372					Regal	3078
Tokai	2356, 2380					Regency	3075
Top Suxess	2364					Rembrandt	3066
Toshiba	2032, 2036, 2037, 2039, 2048, 2049, 2054, 2055, 2072, 2073, 2076, 2078, 2079, 2086, 2145, 2159, 2218, 2233, 2256, 2259, 2296, 2369					Runco	3122
TRANScontinents	2363, 2367					Sagem	3101
Transonic	2367					Samsung	3069, 3089, 3114, 3120
Trio	2362					SAT	3098
Trutech	2242					Scientific Atlanta	3000, 3001, 3002, 3003, 3006, 3028, 3029, 3081, 3086, 3089, 3094, 3095, 3108
TruVision	2359					Signal	3072, 3123
TSM	2364					Signature	3066
Umax	2361					Sony	3092, 3125
United	2367					Sprucer	3118
Urban Concepts	2159					Standard Component	3115
US Logic	2245					Starcom	3017, 3072, 3119, 3123
						Stargate	3072, 3123
						Starquest	3072, 3123
						Supercable	3090
						Supermax	3127

Cable TV

ABC	3002, 3003, 3017, 3066, 3067, 3086, 3093, 3119, 3122
ADB	3020
Adelphia	3081
Alcatel	3016
Americast	3124
Amstrad	3022, 3098
Antronix	3065, 3070
Archer	3070
Arcon	3098
AT&T	3095
Axis	3098
Bell South	3124
Cable Vision	3092
Cabletenna	3065
Cabletime	3104
Cableview	3087
Clearmaster	3127
ClearMax	3127
Clyde Cablevision	3105
Colour Voice	3068
Comcast	3084, 3088, 3117
Comcrypt	3107
Comtronics	3069
Contec	3074
Coolmax	3127
COX	3084
Cryptovision	3110
Director	3084
Eastern	3075
Everquest	3123
Fidelity	3098
Filmnet	3107
Filmnet Cablecrypt	3111
Filmnet Comcrypt	3111
Finlux	3097
Focus	3126
Foxtel	3022
France Telecom	3100, 3101
Freebox	3023
GC Electronics	3070
GE	3066, 3093
GEC	3105
Gemini	3072, 3123
General Instrument	3017, 3025, 3066, 3084, 3090, 3096, 3117
Goldstar	3120
Gooding	3099
Grundig	3098, 3099
Hamlin	3073, 3078
Hirschmann	3097
Hitachi	3066
HomeChoice	3106
Humax	3021, 3080, 3083
ITT Nokia	3097
Jasco	3123

Blu-ray disc player

LG	2033
Panasonic	2011, 2209, 2214
Pioneer	2212
Samsung	2045, 2113
Sharp	2194, 2220, 2221
Sony	2075
Yamaha	2064, 2474

DVR

Bush	2110
Hitachi	2090
Panasonic	2066, 2067, 2093, 2116, 2117, 2119, 2120, 2122, 2123
Philips	2108, 2111
Pioneer	2016, 2017, 2018, 2019, 2092, 2094, 2095, 2109
RCA	2105
Samsung	2113, 2219
Sharp	2088, 2091
Sony	2084, 2085, 2087
Toshiba	2086
Yamaha	2089, 2118

DVD recorder

Aspire	2222
Astar	2240
Broksonic	2146
Go Video	2213
Hitachi	2062
Insignia	2002
Irradio	2053
JVC	2100, 2101, 2106, 2107
LG	2033, 2057, 2223, 2238
Liteon	2043
Panasonic	2011, 2034, 2058, 2062, 2116, 2117, 2119, 2120, 2121, 2123
Philips	2008, 2044, 2050, 2051, 2147
Pioneer	2017, 2035
Pye	2144
Samsung	2000, 2112, 2216
Sansui	2073

Tele+1	3107, 3111	BSkyB	4035, 4041	Europa	4053, 4218, 4219	JOK	4216
Telepiu	3107	BT	4216	Europhon	4219	JSR	4048
Thomson	3082, 3091	Bubu Sat	4217	Eurosat	4011	JVC	4089, 4065, 4117, 4029
TIME WARNER	3084	Bush	4006, 4045	Eurosky	4024, 4011, 4008, 4215, 4218, 4219	Kamm	4217
Tocom	3067	Cambridge	4218	Eurostar	4011, 4215, 4219	Kathrein	4015, 4055, 4053, 4063, 4034, 4042, 4215, 4216, 4217
Torx	3017	Canal Satellite	4213	Eutelsat	4217	Kathrein Eurostar	4215
Toshiba	3122	Canal+	4213	Exator	4001, 4004	Klap	4216
Tristar	3127	CaptiveWorks	4099	Expressvu	4117	Konig	4219
Tudi	3102	Channel Master	4007, 4110	Fenner	4024, 4212, 4217	Kosmos	4049
Tusa	3072, 3123	Chaparral	4075	Ferguson	4006, 4052, 4214	KR	4004
TV86	3077	CHEROKEE	4216	Fidelity	4218	Kreiselmeier	4015
Unika	3065, 3070	Chess	4212, 4217	Finlandia	4006	K-SAT	4217
United Cable	3018, 3119	CityCom	4006, 4215, 4219	Finlux	4006	Kyostar	4001
Universal	3065, 3070	Clatronic	4013	FinnSat	4050, 4052	L&S Electronic	4024
Universum	3097, 3099	CNT	4010	Flair Mate	4217	Lasat	4024, 4010, 4008, 4054, 4215, 4212, 4219
V2	3127	Comag	4080, 4081, 4082, 4083, 4086	Foxtel	4222	Lasonic	4108
Videoway	3019	Commlink	4005	Freecom	4001, 4049, 4218	Lenco	4024, 4001, 4049, 4215, 4219, 4217
View Star	3074, 3077, 3079	Comtech	4050	FTEmaximal	4024, 4217	Leng	4013
Viewmaster	3127	Condor	4008, 4024, 4219	Fuba	4024, 4001, 4008, 4014, 4015, 4055, 4215	Lennox	4048
Vision	3127	Connexions	4014, 4024	Galaxis	4024, 4005, 4008, 4009, 4050, 4048, 4215, 4222	Lenson	4218
Visiopass	3097, 3100, 3101	Conrad	4024, 4215, 4218, 4219	GE	4093, 4066, 4111, 4197	Lexus	4053
Vortex View	3127	Conrad Electronic	4217, 4219	General Instrument	4073, 4019	LG	4103, 4107, 4049
Wittenberg	3098	Contec	4050	GMI	4011	Lifesat	4024, 4008, 4212, 4217
Zenith	3113, 3122, 3124	Coolsat	4096	GOI	4117	Lifetec	4008
Zentek	3126	Cosat	4048	Goldbox	4213	Lorenzen	4219
Satellite TV							
AB Sat	4216, 4217	Coship	4109	GoldStar	4049	Lorraine	4049
AccessHD	4104	Crown	4011	Goodmans	4029, 4002, 4006	Lupus	4024, 4008
ADB	4220	Daeryung	4014	Goodmind	4111	Luxor	4218
AGS	4216	Daewoo	4057, 4217	Grandin	4031	Lyonnaise	4052
Akai	4053, 4055	DDC	4007	Grothusen	4001, 4049	Macab	4052
Alba	4001, 4004, 4006, 4007, 4062, 4217	Delega	4007	Grundig	4006, 4004, 4015, 4035, 4211, 4218, 4222	Magnavox	4127, 4101
Aldes	4005, 4007, 4010	Dew	4050	Hänsel & Gretel	4219	Manata	4031, 4216, 4217
Allsat	4048, 4053, 4055	Diamond	4051	Hantor	4001, 4013	Manhattan	4006, 4010, 4048, 4216
Allsonic	4005, 4008, 4024	Digitality	4219	Hanuri	4010	Marantz	4055
Alltech	4217	Digital Stream	4105	Hauppauge	4044	Mascom	4010
Alpha	4053	DIRECTV	4056, 4064, 4067, 4068, 4070, 4071, 4074, 4107, 4116, 4119, 4121, 4122, 4123, 4127, 4192, 4193, 4194, 4195, 4196, 4197, 4198, 4199, 4200, 4201, 4202, 4203, 4206, 4207, 4221	Heliocom	4219	Maspro	4006, 4217
Alpha Digital	4104	Discoverer	4212	Helium	4219	Matsui	4216
Alphastar	4077	Discovery	4216	Hinari	4007	Max	4219
Amitronica	4217	Diseqc	4216	Hirschmann	4024, 4015, 4210, 4218, 4219, 4216	Mediabox	4213
Amstrad	4011, 4035, 4217, 4218	Dish Network	4018, 4065, 4089, 4092, 4094, 4095, 4117	Hisawa	4013	Mediamarkt	4011
Anglo	4217	Dishpro	4018, 4117	Hisense	4016	Mediasat	4009, 4213, 4218
Ankaro	4005, 4008, 4024, 4217	Distrisat	4053	Hitachi	4114, 4006, 4199, 4203	Medion	4024, 4008, 4217
Anttron	4001, 4004	Ditristrad	4048	Homecast	4087, 4084, 4085	Medison	4217
Apollo	4001	DNT	4014, 4053, 4055	Houston	4048	Mega	4055, 4053
Armstrong	4011, 4053	Drake	4072	HTS	4117	Memorex	4127
Artec	4100	DStv	4222	Hughes	4064, 4068, 4194, 4192, 4196, 4202	Metronic	4031, 4028, 4001, 4004, 4005, 4010, 4217
Asat	4053, 4055	Dune	4024	Hughes Network Systems	4071	Metz	4015
ASLF	4217	Echostar	4014, 4018, 4065, 4089, 4117, 4217	Humax	4097, 4025, 4030, 4060	Micro electronic	4218, 4219, 4217
Astacom	4216	Einhell	4001, 4005, 4011, 4217, 4218	Huth	4005, 4011, 4012, 4013, 4050, 4048, 4219, 4223	Micro Technology	4217
Astracom	4009, 4011, 4054, 4217, 4219	Elap	4216, 4217	Hypson	4031	MicroGem	4106
Astro	4004, 4008, 4010, 4015, 4024, 4213, 4218, 4219	Elekta	4010	Ilo	4016	Micromaxx	4024, 4008
AudioTon	4004, 4048	Elsat	4217	Imex	4031	Microstar	4008
Aurora	4222	Elta	4001, 4008, 4024, 4048, 4053, 4055	Innovation	4008	Microtec	4217
Austar	4222	Emanon	4001	Intertronic	4107	Minerva	4015
Axiel	4216	Emme Esse	4008, 4024	Intervision	4048, 4219	Mitsubishi	4006, 4015, 4202
Axis	4008, 4009, 4024, 4050	Engel	4217	ITT Nokia	4006	Mitsumi	4054
Best	4008, 4024	Ep Sat	4006	Jerrold	4019	Morgan's	4011, 4054, 4055, 4053, 4217
Blaupunkt	4015	EURIEULT	4031	Johansson	4013	Motorola	4090, 4091, 4088, 4019
Blue Sky	4217	Eurodec	4052			Multichoice	4222
Boca	4011, 4054, 4059, 4217					Multitec	4212
Boston	4216					Muratto	4049
Brain Wave	4013					Mysat	4217
Broadcast	4012					Navex	4013
Broco	4217						

Neuhaus	4009, 4048, 4218, 4219, 4217	Roch	4031	Telefunken	4017, 4001, 4216
Neusat	4217	Rover	4024, 4217	Teleka	4004, 4011, 4014, 4218, 4219
Next Level	4019	Saba	4010, 4215, 4219, 4216	Telemaster	4010
NextWave	4223	Sabre	4006	Telesat	4219
Nikko	4011, 4217	Sagem	4023, 4052	Telestari	4212, 4213, 4218
Nokia	4006, 4040	Sakura	4050	Televess	4006, 4218
Nordmende	4001, 4006, 4007, 4010, 4052	Samsung	4064, 4071, 4069, 4123, 4120, 4003, 4000, 4001, 4032, 4196, 4200	Telewire	4048
Nova	4222	SAT	4007, 4218	Tempo	4223
Novis	4013	Sat Cruiser	4223	Tevion	4008, 4217
Oceanic	4051	Sat Partner	4001, 4004, 4010, 4013, 4049, 4218	Thomson	4020, 4006, 4052, 4058, 4208, 4215, 4213, 4219, 4216, 4217
Octagon	4001, 4004, 4050	Sat Team	4217	Thorens	4051
Okano	4011	Satcom	4012, 4219	Thorn	4006
Optex	4048	Satec	4217	Tivax	4104
Optus	4213, 4222, 4223	Satelco	4024	Tivo	4196
Orbitech	4001, 4212, 4213, 4218	Satford	4012	Tokai	4053
OSat	4004	Satmaster	4012	Tonna	4006, 4012, 4048, 4218, 4217
Otto Versand	4015	Satplus	4212	Toshiba	4194, 4202, 4203
Pace	4006, 4015, 4035, 4043, 4047, 4216	Schneider	4008, 4212, 4216	Triad	4049
Pacific	4051	Schwaiger	4051, 4212, 4219	Triasat	4218
Packsat	4216	SCS	4215	Triax	4015, 4215, 4218, 4217
Palcom	4007	Seemann	4011, 4009, 4014	Turnsat	4217
Palladium	4011, 4218	SEG	4024, 4001, 4008, 4013	Tvionics	4214
Palsat	4212, 4218	Seleco	4048	Twinner	4031, 4217
Panasat	4222	Servi Sat	4031, 4217	UEC	4222
Panasonic	4121, 4126, 4124, 4006, 4035, 4036, 4221, 4198	Siemens	4015	Uher	4212
Panda	4006, 4219	Silva	4049	UltimateTV	4070
Pansat	4125	Skantin	4217	Uniden	4079, 4127
Patriot	4216	Skardin	4009	Unisat	4011, 4050, 4053
Paysat	4127	Skinsat	4218	Unitor	4013
PCT	4110	SKR	4217	Universum	4015, 4215, 4219
Philco	4101	Skymaster	4017, 4022, 4005, 4212, 4217	US Digital	4016
Philips	4071, 4068, 4127, 4006, 4055, 4053, 4061, 4033, 4213, 4216, 4196, 4202, 4203, 4201, 4206	Skymax	4055, 4053	Variosat	4015
Phoenix	4050	SkySat	4212, 4218, 4219, 4217	Vega	4024
Phonotrend	4006, 4005, 4048	Skyvision	4048	Ventana	4055, 4053
Pioneer	4046, 4213	SM Electronic	4212, 4217	Viewsat	4098
Polsat	4052	Smart	4215, 4217	Visiosat	4013, 4048, 4216, 4217
Predki	4013	Sony	4067, 4070, 4213	Voom	4019
Premiere	4048, 4213	SR	4011, 4054	Vortec	4001
Priesner	4011	Star Choice	4019	Welltech	4212
Primestar	4076	Starland	4217	WeTeKom	4212, 4218
Profile	4216	Starring	4013	Wevasat	4006
Promax	4006	Start Trak	4001	Wewa	4006
Prosat	4007, 4005	Strong	4024, 4001, 4004, 4008, 4049, 4222	Winersat	4013
Proscan	4093, 4066, 4122, 4197	STS	4115	Wisi	4006, 4014, 4015, 4218, 4219
Protek	4051	STVI	4031	Woorisat	4010
Proton	4016	Sumida	4011	Worldsat	4216
Provision	4010	Sunny Sound	4024	Xrypton	4024
Quadral	4024, 4007, 4005, 4008, 4216	Sunstar	4217	XSat	4217
Quelle	4015, 4215, 4219	Supermax	4024, 4011, 4054	Zehnder	4024, 4010, 4008, 4209, 4215
Quiero	4052	Tandberg	4223	Zenith	4102, 4107, 4195
RadioShack	4019	Tandy	4052	Zodiac	4004
Radiola	4055, 4053	Tantec	4004		
Radix	4014, 4037	TCM	4006		
Rainbow	4004	Techniland	4008		
RCA	4093, 4066, 4112, 4113, 4118, 4119, 4116, 4122, 4197, 4207	TechniSat	4012		
Realistic	4078	TechniSat	4021, 4026, 4027, 4014, 4053, 4038, 4039, 4212, 4213, 4218		
Redpoint	4009	Technology	4222		
Redstar	4024, 4008	Technosat	4223		
RFT	4005, 4055, 4053	Technowelt	4219		
Roadstar	4217	Teco	4011, 4054		
		Telanor	4007		
		Telasat	4215, 4219		
		Telecom	4217		

Tape deck

Yamaha 5084, 5087

LD player

Yamaha 2080

CD player

Yamaha 5082, 5095

CD recorder

Yamaha 5083

MD recorder

Yamaha 5080, 5081, 5086

