



# *RX-V2700*

---

*AV Receiver*

OWNER'S MANUAL

# IMPORTANT SAFETY INSTRUCTIONS

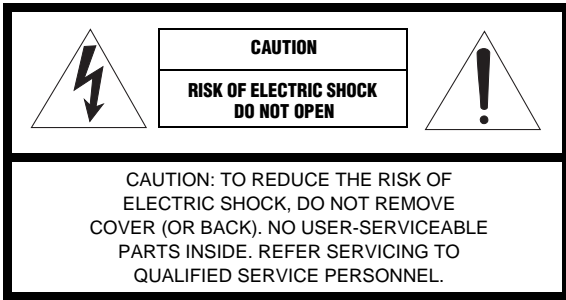

## • Explanation of Graphical Symbols

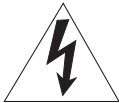

The lightning flash with arrowhead symbol, within an equilateral triangle, is intended to alert you to the presence of uninsulated “dangerous voltage” within the product’s enclosure that may be of sufficient magnitude to constitute a risk of electric shock to persons.



The exclamation point within an equilateral triangle is intended to alert you to the presence of important operating and maintenance (servicing) instructions in the literature accompanying the appliance.

- 1 Read Instructions – All the safety and operating instructions should be read before the product is operated.
  - 2 Retain Instructions – The safety and operating instructions should be retained for future reference.
  - 3 Heed Warnings – All warnings on the product and in the operating instructions should be adhered to.
  - 4 Follow Instructions – All operating and use instructions should be followed.
  - 5 Cleaning – Unplug this product from the wall outlet before cleaning. Do not use liquid cleaners or aerosol cleaners.
  - 6 Attachments – Do not use attachments not recommended by the product manufacturer as they may cause hazards.
  - 7 Water and Moisture – Do not use this product near water – for example, near a bath tub, wash bowl, kitchen sink, or laundry tub; in a wet basement; or near a swimming pool; and the like.
  - 8 Accessories – Do not place this product on an unstable cart, stand, tripod, bracket, or table. The product may fall, causing serious injury to a child or adult, and serious damage to the product. Use only with a cart, stand, tripod, bracket, or table recommended by the manufacturer, or sold with the product. Any mounting of the product should follow the manufacturer’s instructions, and should use a mounting accessory recommended by the manufacturer.
  - 9 A product and cart combination should be moved with care. Quick stops, excessive force, and uneven surfaces may cause the product and cart combination to overturn.
- 
- 10 Ventilation – Slots and openings in the cabinet are provided for ventilation and to ensure reliable operation of the product and to protect it from overheating, and these openings must not be blocked or covered. The openings should never be blocked by placing the product on a bed, sofa, rug, or other similar surface. This product should not be placed in a built-in installation such as a bookcase or rack unless proper ventilation is provided or the manufacturer’s instructions have been adhered to.
  - 11 Power Sources – This product should be operated only from the type of power source indicated on the marking label. If you are not sure of the type of power supply to your home, consult your product dealer or local power company. For products intended to operate from battery power, or other sources, refer to the operating instructions.
  - 12 Grounding or Polarization – This product may be equipped with a polarized alternating current line plug (a plug having one blade wider than the other). This plug will fit into the power outlet only one way. This is a safety feature. If you are unable to insert the plug fully into the outlet, try reversing the plug. If the plug should still fail to fit, contact your electrician to replace your obsolete outlet. Do not defeat the safety purpose of the polarized plug.
  - 13 Power-Cord Protection – Power-supply cords should be routed so that they are not likely to be walked on or pinched by items placed upon or against them, paying particular attention to cords at plugs, convenience receptacles, and the point where they exit from the product.
  - 14 Lightning – For added protection for this product during a lightning storm, or when it is left unattended and unused for long periods of time, unplug it from the wall outlet and disconnect the antenna or cable system. This will prevent damage to the product due to lightning and power-line surges.
  - 15 Power Lines – An outside antenna system should not be located in the vicinity of overhead power lines or other electric light or power circuits, or where it can fall into such power lines or circuits. When installing an outside antenna system, extreme care should be taken to keep from touching such power lines or circuits as contact with them might be fatal.
  - 16 Overloading – Do not overload wall outlets, extension cords, or integral convenience receptacles as this can result in a risk of fire or electric shock.
  - 17 Object and Liquid Entry – Never push objects of any kind into this product through openings as they may touch dangerous voltage points or short-out parts that could result in a fire or electric shock. Never spill liquid of any kind on the product.
  - 18 Servicing – Do not attempt to service this product yourself as opening or removing covers may expose you to dangerous voltage or other hazards. Refer all servicing to qualified service personnel.
  - 19 Damage Requiring Service – Unplug this product from the wall outlet and refer servicing to qualified service personnel under the following conditions:
    - a) When the power-supply cord or plug is damaged,
    - b) If liquid has been spilled, or objects have fallen into the product,
    - c) If the product has been exposed to rain or water,

- d) If the product does not operate normally by following the operating instructions. Adjust only those controls that are covered by the operating instructions as an improper adjustment of other controls may result in damage and will often require extensive work by a qualified technician to restore the product to its normal operation,
  - e) If the product has been dropped or damaged in any way, and
  - f) When the product exhibits a distinct change in performance - this indicates a need for service.
- 20 Replacement Parts** – When replacement parts are required, be sure the service technician has used replacement parts specified by the manufacturer or have the same characteristics as the original part. Unauthorized substitutions may result in fire, electric shock, or other hazards.
- 21 Safety Check** – Upon completion of any service or repairs to this product, ask the service technician to perform safety checks to determine that the product is in proper operating condition.
- 22 Wall or Ceiling Mounting** – The unit should be mounted to a wall or ceiling only as recommended by the manufacturer.
- 23 Heat** – The product should be situated away from heat sources such as radiators, heat registers, stoves, or other products (including amplifiers) that produce heat.

- 24 Outdoor Antenna Grounding** – If an outside antenna or cable system is connected to the product, be sure the antenna or cable system is grounded so as to provide some protection against voltage surges and built-up static charges. Article 810 of the National Electrical Code, ANSI/NFPA 70, provides information with regard to proper grounding of the mast and supporting structure, grounding of the lead-in wire to an antenna discharge unit, size of grounding conductors, location of antenna discharge unit, connection to grounding electrodes, and requirements for the grounding electrode.

EXAMPLE OF ANTENNA GROUNDING

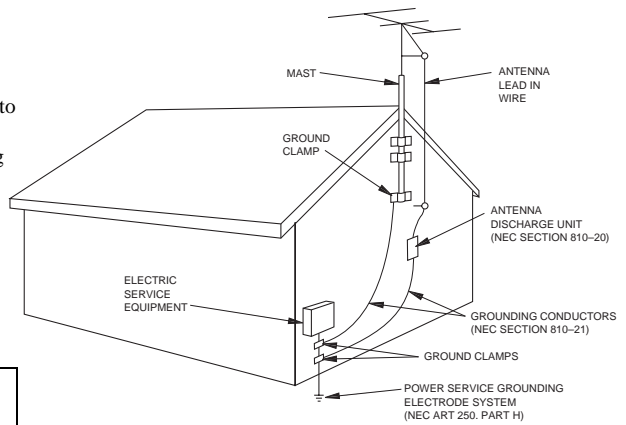

NEC – NATIONAL ELECTRICAL CODE

**Note to CATV system installer:**

This reminder is provided to call the CATV system installer’s attention to Article 820-40 of the NEC that provides guidelines for proper grounding and, in particular, specifies that the cable ground shall be connected to the grounding system of the building, as close to the point of cable entry as practical.

**FCC INFORMATION (for US customers)**

**1 IMPORTANT NOTICE: DO NOT MODIFY THIS UNIT!**

This product, when installed as indicated in the instructions contained in this manual, meets FCC requirements. Modifications not expressly approved by Yamaha may void your authority, granted by the FCC, to use the product.

- 2 IMPORTANT:** When connecting this product to accessories and/or another product use only high quality shielded cables. Cable/s supplied with this product **MUST** be used. Follow all installation instructions. Failure to follow instructions could void your FCC authorization to use this product in the USA.

- 3 NOTE:** This product has been tested and found to comply with the requirements listed in FCC Regulations, Part 15 for Class “B” digital devices. Compliance with these requirements provides a reasonable level of assurance that your use of this product in a residential environment will not result in harmful interference with other electronic devices.

This equipment generates/uses radio frequencies and, if not installed and used according to the instructions found in the users manual, may cause interference harmful to the operation of other electronic devices.

Compliance with FCC regulations does not guarantee that interference will not occur in all installations. If this product is found to be the source of interference, which can be determined by turning the unit “OFF” and “ON”, please try to eliminate the problem by using one of the following measures:

Relocate either this product or the device that is being affected by the interference.

Utilize power outlets that are on different branch (circuit breaker or fuse) circuits or install AC line filter/s.

In the case of radio or TV interference, relocate/reorient the antenna. If the antenna lead-in is 300 ohm ribbon lead, change the lead-in to coaxial type cable.

If these corrective measures do not produce satisfactory results, please contact the local retailer authorized to distribute this type of product. If you can not locate the appropriate retailer, please contact Yamaha Electronics Corp., U.S.A. 6660 Orangethorpe Ave, Buena Park, CA 90620.

The above statements apply **ONLY** to those products distributed by Yamaha Corporation of America or its subsidiaries.

# CAUTION: READ THIS BEFORE OPERATING YOUR UNIT.

- 1 To assure the finest performance, please read this manual carefully. Keep it in a safe place for future reference.
- 2 Install this sound system in a well ventilated, cool, dry, clean place – away from direct sunlight, heat sources, vibration, dust, moisture, and/or cold. Allow ventilation space of at least 30 cm on the top, 20 cm on the left and right, and 20 cm on the back of this unit.
- 3 Locate this unit away from other electrical appliances, motors, or transformers to avoid humming sounds.
- 4 Do not expose this unit to sudden temperature changes from cold to hot, and do not locate this unit in an environment with high humidity (i.e. a room with a humidifier) to prevent condensation inside this unit, which may cause an electrical shock, fire, damage to this unit, and/or personal injury.
- 5 Avoid installing this unit where foreign objects may fall onto this unit and/or this unit may be exposed to liquid dripping or splashing. On the top of this unit, do not place:
  - Other components, as they may cause damage and/or discoloration on the surface of this unit.
  - Burning objects (i.e. candles), as they may cause fire, damage to this unit, and/or personal injury.
  - Containers with liquid in them, as they may fall and liquid may cause electrical shock to the user and/or damage to this unit.
- 6 Do not cover this unit with a newspaper, tablecloth, curtain, etc. in order not to obstruct heat radiation. If the temperature inside this unit rises, it may cause fire, damage to this unit, and/or personal injury.
- 7 Do not plug in this unit to a wall outlet until all connections are complete.
- 8 Do not operate this unit upside-down. It may overheat, possibly causing damage.
- 9 Do not use force on switches, knobs and/or cords.
- 10 When disconnecting the power cable from the wall outlet, grasp the plug; do not pull the cable.
- 11 Do not clean this unit with chemical solvents; this might damage the finish. Use a clean, dry cloth.
- 12 Only voltage specified on this unit must be used. Using this unit with a higher voltage than specified is dangerous and may cause fire, damage to this unit, and/or personal injury. YAMAHA will not be held responsible for any damage resulting from use of this unit with a voltage other than specified.
- 13 To prevent damage by lightning, keep the power cord and outdoor antennas disconnected from a wall outlet or the unit during a lightning storm.
- 14 Do not attempt to modify or fix this unit. Contact qualified YAMAHA service personnel when any service is needed. The cabinet should never be opened for any reasons.
- 15 When not planning to use this unit for long periods of time (i.e. vacation), disconnect the AC power plug from the wall outlet.
- 16 Install this unit near the AC outlet and where the AC power plug can be reached easily.
- 17 Be sure to read the “TROUBLESHOOTING” section on common operating errors before concluding that this unit is faulty.
- 18 Before moving this unit, press MASTER ON/OFF to release it outward to the OFF position to turn off this unit, the main room, Zone 2 and Zone 3 and then disconnect the AC power plug from the AC wall outlet.
- 19 **VOLTAGE SELECTOR** (Asia and General models only)  
The VOLTAGE SELECTOR on the rear panel of this unit must be set for your local main voltage BEFORE plugging into the AC wall outlet. Voltages are as follows:  
..... 110/120/220/230–240 V AC, 50/60 Hz

## WARNING

TO REDUCE THE RISK OF FIRE OR ELECTRIC SHOCK, DO NOT EXPOSE THIS UNIT TO RAIN OR MOISTURE.

As long as this unit is connected to the AC wall outlet, it is not disconnected from the AC power source even if you turn off this unit by MASTER ON/OFF. In this state, this unit is designed to consume a very small quantity of power.

## FOR CANADIAN CUSTOMERS

To prevent electric shock, match wide blade of plug to wide slot and fully insert.  
This Class B digital apparatus complies with Canadian ICES-003.

## POUR LES CONSOMMATEURS CANADIENS

Pour éviter les chocs électriques, introduire la lame la plus large de la fiche dans la borne correspondante de la prise et pousser jusqu'au fond.  
Cet appareil numérique de la classe B est conforme à la norme NMB-003 du Canada.

## IMPORTANT

Please record the serial number of this unit in the space below.  
**MODEL:**  
Serial No.:  
The serial number is located on the rear of the unit. Retain this Owner's Manual in a safe place for future reference.

## COMPLIANCE INFORMATION STATEMENT (DECLARATION OF CONFORMITY PROCEDURE)

Responsible Party: Yamaha Electronics Corporation, U.S.A.  
Address: 6660 Orangethorpe Avenue  
Buena Park, CA 90620  
Telephone: 714-522-9105  
Fax: 714-670-0108  
Type of Equipment: AV Receiver  
Model Name: RX-V2700

- This device complies with Part 15 of the FCC Rules.
  - Operation is subject to the following conditions:
    - This device may not cause harmful interference.
    - This device must accept any interference received including interference that may cause undesired operation.
- See the “TROUBLESHOOTING” section at the end of this manual if interference to radio reception is suspected.

# TRADEMARK NOTICES



Manufactured under license from Dolby Laboratories. "Dolby", "Pro Logic", and the double-D symbol are trademarks of Dolby Laboratories.



Manufactured under license from Digital Theater Systems, Inc. "DTS", "DTS-ES", "NEO:6", and "DTS 96/24" are trademarks of Digital Theater Systems, Inc. Copyright 1996, 2003 Digital Theater Systems, Inc. All right reserved.

## iPod®

"iPod" is a trademark of Apple Computer, Inc., registered in the U.S. and other countries.



## Fraunhofer Institut Integrierte Schaltungen

MPEG Layer-3 audio coding technology licensed from Fraunhofer IIS and Thomson.



This receiver supports network connections.



"HDMI", the "HDMI" logo and "High-Definition Multimedia Interface" are trademarks or registered trademarks of HDMI Licensing LLC.

SILENT™  
CINEMA

"SILENT CINEMA" is a trademark of YAMAHA CORPORATION.



The XM name and related logos are registered trademarks of XM Satellite Radio Inc.



Neural Surround™ name and related logos are trademarks owned by Neural Audio Corporation.

Windows XP, Windows Media Audio, Windows Media Connect are either registered trademarks or trademarks of Microsoft corporation in the United States and/or countries.

## Note on Source Code Distribution

This product includes software code subject to the GNU General Public License (GPL) or the GNU Lesser General Public License (LGPL). The copy, distribution, or change of this software code is licensed under the terms of the GPL or the LGPL. The source code is available at the following website:  
<http://www.global.yamaha.com/download/>

The source code is also available on a physical media (such as a CD-ROM) at actual cost.

Contact: AV products division, YAMAHA CORPORATION,  
10-1 Nakazawa-cho, Hamamatsu 430-8650, Japan

In principle, the source code is offered for 3 years from the day of purchase.

## We Want You Listening For A Lifetime



YAMAHA and the Electronic Industries Association's Consumer Electronics Group want you to get the most out of your equipment by playing it at a safe level. One that lets the sound come through loud and clear without annoying blaring or distortion – and, most importantly, without affecting your sensitive hearing. Since hearing damage from loud sounds is often undetectable until it is too late, YAMAHA and the Electronic Industries Association's Consumer Electronics Group recommend you to avoid prolonged exposure from excessive volume levels.

# CONTENTS

## INTRODUCTION

<b>FEATURES</b> .....	<b>4</b>
<b>GETTING STARTED</b> .....	<b>5</b>
Supplied accessories .....	5
<b>CONTROLS AND FUNCTIONS</b> .....	<b>6</b>
Front panel .....	6
Remote control .....	8
Zone 2/Zone 3 remote control .....	10
Preparing the remote control .....	11
Front panel display .....	12
Rear panel .....	14

## PREPARATION

<b>CONNECTIONS</b> .....	<b>15</b>
Placing speakers .....	15
Connecting speakers .....	16
Using bi-amplification connections .....	19
Information on jacks and cable plugs .....	20
Information on HDMI .....	21
Audio and video signal flow .....	22
Connecting a TV monitor or projector .....	23
Connecting other components .....	24
Connecting a multi-format player or an external decoder .....	28
Connecting a YAMAHA iPod universal dock .....	29
Using the VIDEO AUX jacks on the front panel .....	29
Connecting the network .....	30
Connecting the FM and AM antennas .....	31
Connecting the power cable .....	32
Setting the speaker impedance .....	33
Turning on and off the power .....	34
<b>AUTO SETUP</b> .....	<b>35</b>
Using Auto Setup .....	35

## BASIC OPERATION

<b>PLAYBACK</b> .....	<b>40</b>
Basic procedure .....	40
Selecting audio input jacks (AUDIO SELECT) .....	42
Selecting the MULTI CH INPUT component .....	43
Using your headphones .....	43
Muting the audio output .....	43
Operating the amplifier functions of this unit by using the graphical user interface (GUI) screen .....	44
Playing video sources in the background of an audio source .....	45
Using the sleep timer .....	45
<b>SOUND FIELD PROGRAMS</b> .....	<b>46</b>
Selecting sound field programs .....	46
Sound field program descriptions .....	47
Enjoying unprocessed input sources .....	51

## USING AUDIO FEATURES

Enjoying pure hi-fi sound .....	52
Adjusting the tonal quality .....	52
Adjusting the speaker level .....	53
Enjoying multi-channel sources in 2-channel stereo .....	53
Selecting the Compressed Music Enhancer mode .....	54
Selecting the night listening mode .....	55

## FM/AM TUNING

FM/AM controls and functions .....	56
Automatic tuning .....	57
Manual tuning .....	58
Automatic preset tuning .....	59
Manual preset tuning .....	60
Selecting preset stations .....	61
Exchanging preset stations .....	62

## XM SATELLITE RADIO TUNING

Connecting the XM Passport System .....	63
XM Satellite Radio controls and functions .....	64
Activating XM Satellite Radio .....	65
Basic XM Satellite Radio operations .....	67
Setting the XM Satellite Radio preset channels .....	72
Displaying the XM Satellite Radio information .....	73

## USING iPod

Controlling iPod .....	75
------------------------	----

## USING NETWORK/USB FEATURES

Navigating the network and USB menus .....	77
Using a PC server or YAMAHA MCX-2000 .....	79
Using the Internet Radio .....	80
Using a USB memory device or a USB portable audio player .....	81
Using shortcut buttons .....	81

## RECORDING

## ADVANCED OPERATION

### ADVANCED SOUND CONFIGURATIONS

Selecting decoders .....	84
--------------------------	----

### GRAPHIC USER INTERFACE (GUI)

<b>SCREEN</b> .....	<b>87</b>
Stereo/Surround (Stereo/Surround menu) .....	88
Input Select .....	94
Manual Setup (Sound) .....	97
Manual Setup (Video) .....	101
Manual Setup (Basic) .....	104
Manual Setup (NET/USB) .....	109
Manual Setup (Option) .....	111
System Memory .....	115
Signal Info. (Input signal information) .....	116
Language .....	117

**REMOTE CONTROL FEATURES..... 118**  
 Controlling this unit, a TV,  
 or other components ..... 118  
 Setting remote control codes ..... 120  
 Programming codes from other remote controls ... 122  
 Changing source names in the display window .... 123  
 Macro programming features ..... 124  
 Clearing configurations ..... 127  
**USING MULTI-ZONE CONFIGURATION .. 130**  
 Connecting the Zone 2 and Zone 3 components ... 130  
 Controlling Zone 2 or Zone 3 ..... 131  
**ADVANCED SETUP ..... 134**  
 Using ADVANCED SETUP ..... 134  
 Setting remote control ID ..... 137

**ADDITIONAL INFORMATION**

**TROUBLESHOOTING..... 139**  
**RESETTING THE SYSTEM..... 149**  
**GLOSSARY ..... 150**  
**SOUND FIELD PROGRAM**  
**INFORMATION ..... 153**  
**PARAMETRIC EQUALIZER**  
**INFORMATION ..... 154**  
**SPECIFICATIONS ..... 155**

**APPENDIX**

(at the end of this manual)

**SOUND OUTPUT**  
**IN EACH SOUND FIELD PROGRAM ..... i**  
**GNU GENERAL PUBLIC LICENSE..... v**  
**GNU LESSER GENERAL PUBLIC**  
**LICENSE..... vi**  
**LIST OF REMOTE CONTROL CODE ..... ix**

**About this manual**

- ※ indicates a tip for your operation.
- Some operations can be performed by using either the buttons on the front panel or the ones on the remote control. In case the button names differ between the front panel and the remote control, the button name on the remote control is given in parentheses.
- This manual is printed prior to production. Design and specifications are subject to change in part as a result of improvements, etc. In case of differences between the manual and product, the product has priority.
- This unit equips GUI display menu language switching capability. In this manual, the illustrations of the GUI are examples when you set the GUI language to English.

# FEATURES

## Built-in 7-channel power amplifier

- ◆ Minimum RMS output power (20 Hz to 20 kHz, 0.04% THD, 8 Ω)  
Front: 140 W + 140 W  
Center: 140 W  
Surround: 140 W + 140 W  
Surround back: 140 W + 140 W

## Sound field programs

- ◆ Proprietary YAMAHA technology for the creation of sound fields
- ◆ Dolby Digital/Dolby Digital EX decoder
- ◆ DTS/DTS-ES Matrix 6.1, Discrete 6.1, DTS Neo:6, DTS 96/24 decoder
- ◆ Dolby Pro Logic/Dolby Pro Logic II/Dolby Pro Logic IIX decoder
- ◆ Neural Surround decoder (U.S.A. and Canada models only)
- ◆ Virtual CINEMA DSP
- ◆ SILENT CINEMA

## Sophisticated AM/FM tuner

- ◆ 40-station random and direct preset tuning
- ◆ Automatic preset tuning
- ◆ Preset station shifting capability (preset editing)

## XM Satellite Radio

### (U.S.A. and Canada models only)

- ◆ XM Satellite Radio tuning capability (using the “XM Passport System” sold separately)
- ◆ Neural Surround decoder to play back the surround sound content of XM Satellite Radio broadcasts in multi-channels, resulting in a full surround sound experience

## HDMI (High-Definition Multimedia Interface)

- ◆ HDMI interface for standard, enhanced or high-definition video (includes 1080p video signal transmission) as well as multi-channel digital audio based on HDMI version 1.2a
- ◆ Analog video to HDMI digital video up-conversion (composite video ↔ S-video ↔ component video → HDMI digital video) capability for monitor out
- ◆ Analog video up-scaling from 480i (NTSC)/576i (PAL) or 480p/576p to 720p or 1080i

## iPod controlling capability

- ◆ DOCK terminal to connect a YAMAHA iPod universal dock (such as the YDS-10, sold separately), which supports iPod (Click and Wheel), iPod nano, and iPod mini

## Network features

- ◆ NETWORK port to connect a PC and YAMAHA MCX-2000 or access the Internet Radio via a LAN
- ◆ DHCP automatic or manual network configuration

## USB features

- ◆ USB port to connect a USB memory device or a USB portable audio player

## Other features

- ◆ YPAO (YAMAHA Parametric Room Acoustic Optimizer) for automatic speaker setup
- ◆ 192-kHz/24-bit D/A converter
- ◆ GUI (graphical user interface) menus that allows you to optimize this unit to suit your individual audio/video system
- ◆ GUI display menu language switching capability (English, Japanese, French, German, Spanish and Russian)
- ◆ 6 or 8-channel additional input jacks for discrete multi-channel input
- ◆ Analog video interlace/progressive conversion from 480i (NTSC)/576i (PAL) to 480p/576p
- ◆ S-video signal input/output capability
- ◆ Component video input/output capability includes (3 COMPONENT VIDEO INs and 1 MONITOR OUT)
- ◆ Optical and coaxial digital audio signal jacks
- ◆ Pure Direct mode for pure hi-fi sound for all sources
- ◆ Cinema and music night listening modes
- ◆ Compressed Music Enhancer mode to improve the sound quality of compression artifacts (such as the MP3 format) to that of a high-quality stereo
- ◆ Remote control with preset remote control codes, learning, macro and buttons and display backlight capability
- ◆ ZONE 2/ZONE 3 custom installation facility
- ◆ Zone switching capability between the main zone and ZONE 2/ZONE 3 using ZONE CONTROLS
- ◆ Zone 2 OSD (on-screen display) capability
- ◆ Sleep timer



# GETTING STARTED

## Supplied accessories

Check that you received all of the following parts.

### Remote control

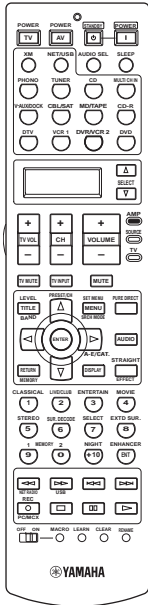

### Zone 2/Zone 3 remote control

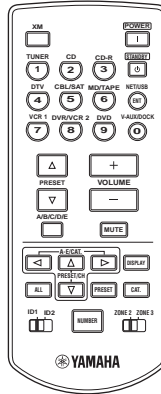

### Batteries (6) (AAA, LR03)

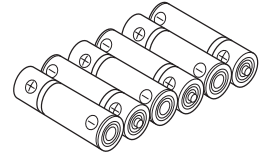

### Speaker terminal wrench

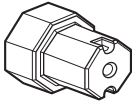

### Power cable

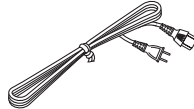

### Optimizer microphone

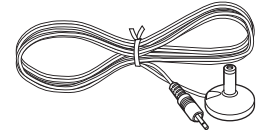

### Indoor FM antenna (U.S.A., Canada, China, Asia, General, and Korea models)

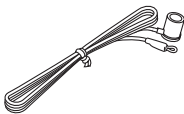

### Indoor FM antenna (Europe, U.K. and Australia models)

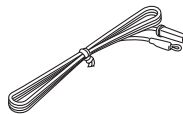

### AM loop antenna



# CONTROLS AND FUNCTIONS

## Front panel

This section describes only the amplifier controls and functions of this unit. See the following pages for details about other control and functions.

- AM/FM tuning ..... see page 56
- XM satellite radio tuning ..... see page 64

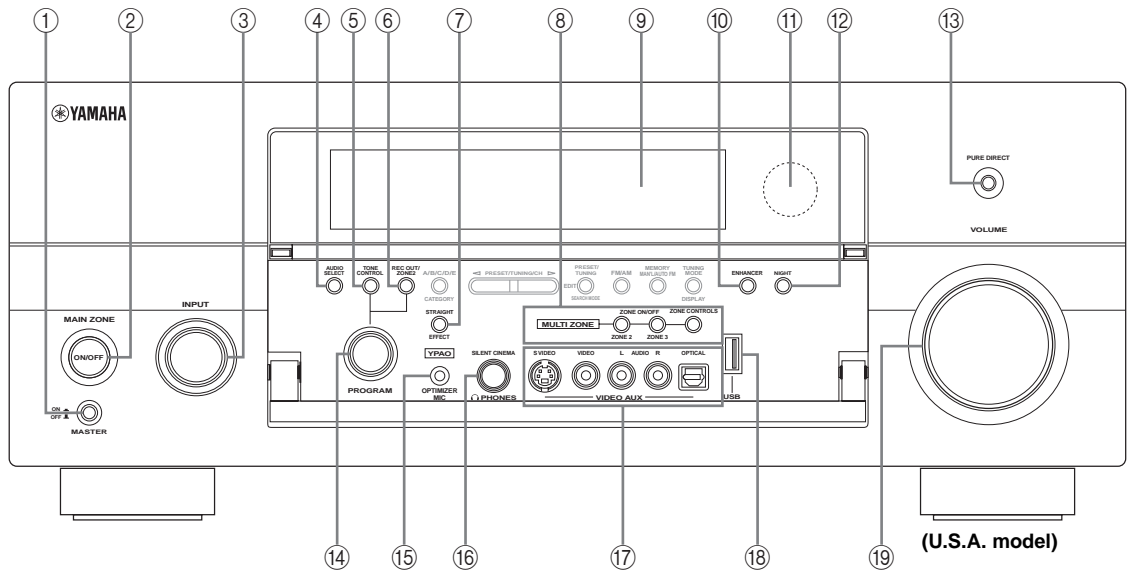

### ① MASTER ON/OFF

Turns this unit on or off (see page 34).

### ② MAIN ZONE ON/OFF

Turns on the main zone or sets it to the standby mode (see page 34).

### Notes

- In the standby mode, this unit consumes a small amount of power in order to receive infrared signals from the remote control.
- When you turn on this unit, there will be a 4 to 5-second delay before this unit can reproduce sound.
- This button is operational only when MASTER ON/OFF is pressed inward to the ON position.

### ③ INPUT selector

Selects the desired input source (see page 40).

### ④ AUDIO SELECT

Toggles the priority for the type of audio input jack between “AUTO”, “HDMI”, “COAX/OPT” and “ANALOG” when one component is connected to two or more input jacks (see page 42).

### ⑤ TONE CONTROL

Adjusts the bass/treble balance of the front left, front right and center channels in conjunction with the PROGRAM selector (see page 52).

### ⑥ REC OUT/ZONE2

Selects the input source you want to direct to the audio/video recorder and Zone 2 outputs independently of the input source you are listening to or watching in the main zone (see page 83).

### ⑦ STRAIGHT

Turns the sound field programs off or on. When the “STRAIGHT” mode is selected, 2-channel or multi-channel input signals are output directly from their respective speakers without effect processing (see page 51).

**⑧ MULTI ZONE buttons****ZONE 2 ON/OFF**

Turns on Zone 2 only or sets it to the standby mode (see page 131).

**ZONE 3 ON/OFF**

Turns on Zone 3 only or sets it to the standby mode (see page 131).

**Note**

These buttons are operational only when MASTER ON/OFF is pressed inward to the ON position.

**ZONE CONTROLS**

Switches the zone you want to control between the main zone, Zone 2 and Zone 3 (see page 131).



After you press ZONE CONTROLS, the indicator for the currently selected zone flashes in the front panel display for approximately 5 seconds. While the indicator is flashing, perform the desired operation.

**⑨ Front panel display**

Shows information about the operational status of this unit (see page 12).

**⑩ ENHANCER**

Turns on or off the Compressed Music Enhancer mode (see page 54).

**⑪ Remote control sensor**

Receives signals from the remote control (see page 11).

**⑫ NIGHT**

Turns on or off the night listening modes (see page 55).

**⑬ PURE DIRECT**

Turns on or off the Pure Direct mode (see page 52).

**⑭ PROGRAM selector**

- Selects sound field programs (see page 46).
- Adjusts the bass/treble balance in conjunction with TONE CONTROL (see page 52).

**⑮ OPTIMIZER MIC jack**

Use to connect and input audio signals from the supplied optimizer microphone in the “Auto Setup” procedure (see page 35).

**⑯ PHONES jack**

Outputs audio signals for private listening with headphones (see page 43).

**⑰ VIDEO AUX jacks**

Input audio and video signals from a portable external source such as a game console or a video camera (see page 29).



To reproduce the source signals input at these jacks, select “V-AUX” as the input source.

**Note**

The audio signals input at the DOCK terminal on the rear panel take priority over the ones input at the VIDEO AUX jacks.

**⑱ USB port**

Use to connect a USB memory device or a USB portable audio player (see page 81).

**⑲ VOLUME**

Controls the output level of all audio channels.



This does not affect the AUDIO OUT (REC) level.

**■ Opening and closing the front panel door**

When you want to use the controls behind the front panel door, open the door by gently pressing on the lower part of the panel. Keep the door closed when not using these controls.

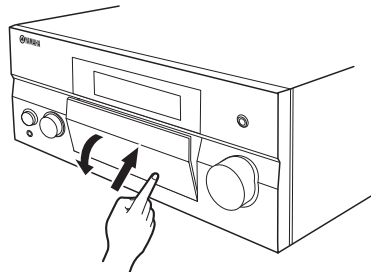

To open, press gently on the lower part of the panel.

## Remote control

### Remote control controls and functions

This section describes only the amplifier controls and functions of this unit. See the following pages for details about other control and functions.

- AM/FM tuning ..... see page 56
- XM satellite radio tuning ..... see page 64
- Controlling a TV ..... see page 118
- Controlling other components ..... see page 119
- Controlling option components ..... see page 120

#### Note

The operation mode of the remote control buttons in the shaded area below depends on the operation mode selector position. Set the operation mode selector to AMP to control this unit.

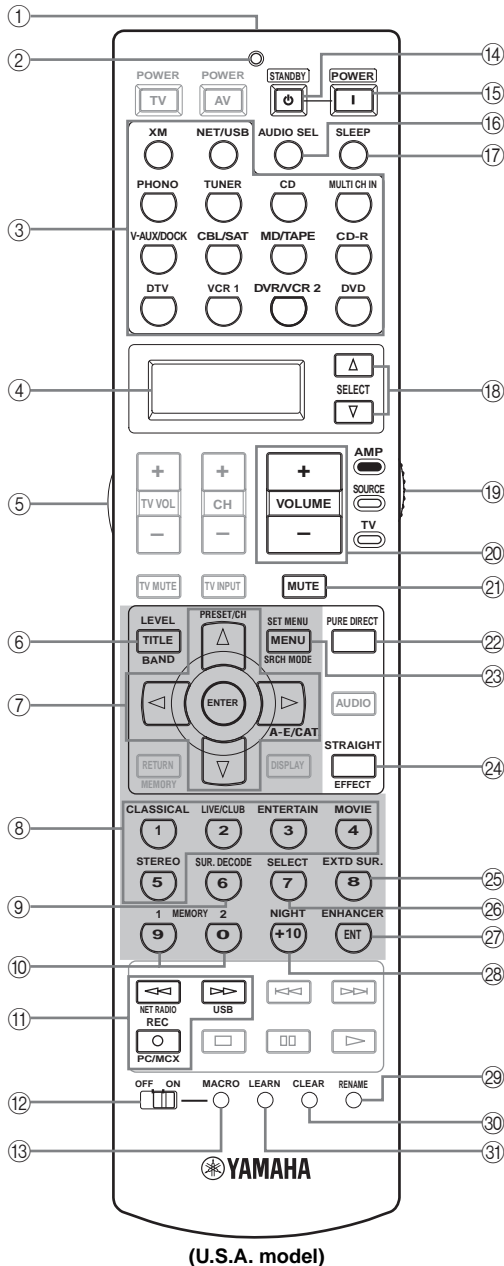

#### ① Infrared window

Outputs infrared control signals. Aim this window at the component you want to operate (see page 11).

#### ② TRANSMIT indicator

Flashes while the remote control is sending infrared signals.

#### ③ Input selector buttons

Select the input source you want to control.



The selected input source name appears in the display window on the remote control showing which source is currently operational.

#### ④ Display window

Shows the name of the selected input source that you can control.

#### ⑤ LIGHT

Lights up the remote control buttons and the display window.

#### ⑥ LEVEL

Selects the speaker channel to be adjusted and sets the output level (see page 53).

#### ⑦ Cursor buttons $\Delta / \nabla / \triangleleft / \triangleright$ , ENTER

Move the items or cursor and adjust the parameters in the GUI screens or front panel display.

#### ⑧ Sound field program selector buttons

Select sound field programs (see page 46).

#### ⑨ SUR. DECODE

Activates decoders to play back 2-channel sources in surround (see page 84).

#### ⑩ MEMORY 1/2

Recalls “MEMORY 1” or “MEMORY 2” of “System Memory” (see page 115).

#### ⑪ Network and USB input selector buttons

Select the sub input source of NET/USB (see page 78).

#### PC/MCX

Selects a PC server or YAMAHA MCX-2000 as the sub input source of NET/USB.

**NET RADIO**

Selects the Internet radio as the sub input source of NET/USB.

**USB**

Selects a USB memory device or a USB portable audio player as the sub input source of NET/USB.

**Notes**

- Press NET/USB to select “NET/USB” as the input source before you press any of the network and USB input selector buttons stated above to select the corresponding sub input source of NET/USB.
- When you press any of the network and USB input selector buttons, the contents previously played for the corresponding sub input source of NET/USB is automatically played.

**⑫ MACRO ON/OFF**

Turns on or off the macro function (see page 124).

**⑬ MACRO**

Programs a series of operations to be controlled with a single button (see page 124).

**⑭ STANDBY**

Sets the main zone to the standby mode (see page 34).

**Note**

This button is operational only when MASTER ON/OFF on the front panel is pressed inward to the ON position.

**⑮ POWER**

Turns on the main zone (see page 34).

**Note**

This button is operational only when MASTER ON/OFF on the front panel is pressed inward to the ON position.

**⑯ AUDIO SEL**

Toggles the priority for the type of audio input jack between “AUTO”, “HDMI”, “COAX/OPT” and “ANALOG” when one component is connected to two or more input jacks (see page 42).

**⑰ SLEEP**

Sets the sleep timer (see page 45).

**⑱ SELECT  $\Delta$  /  $\nabla$** 

Selects another input source that you can control independently of the input source selected with the input selector buttons.

**⑲ Operation mode selector**

Selects the operation mode of the remote control buttons in the shaded area.

**AMP**

Operates the amplifier function of this unit.

**SOURCE**

Operates the component selected with an input selector button (see page 119).

**TV**

Operates the TV assigned to either DTV or PHONO (see page 118).

**Notes**

- To set the remote control codes for other components, see page 120.
- When you set the remote control codes for both DTV and PHONO (see page 120), priority is given to the one set for DTV.

**⑳ VOLUME +/-**

Increases or decreases the volume level.

**㉑ MUTE**

Mutes the audio output. Press again to restore the audio output to the previous volume level (see page 43).

**㉒ PURE DIRECT**

Turns on or off the pure direct mode (see page 52).

**㉓ SET MENU**

Activates the GUI screen (see page 44).

**㉔ STRAIGHT**

Turns the sound field programs off or on. When the “STRAIGHT” mode is selected, 2-channel or multi-channel input signals are output directly from their respective speakers without effect processing (see page 51).

**㉕ EXTD SUR.**

Switches between 5.1 and 6.1/7.1-channel playback of multi-channel sources (see page 84).

**㉖ SELECT**

Selects decoders for 2-channel sources (see pages 84 and 85).

**㉗ ENHANCER**

Turns on or off the Compressed Music Enhancer mode (see page 54).

**㉘ NIGHT**

Turns on or off the night listening modes (see page 55).

**㉙ RENAME**

Changes the name of the input source in the display window (see page 123).

**㉚ CLEAR**

Clears remote control functions acquired from the learn, macro and/or rename features (see page 127).

**㉛ LEARN**

Programs remote control codes of functions from other remote controls (see page 122).

## Zone 2/Zone 3 remote control

This section describes the function of each control on the Zone 2/Zone 3 remote control used to control the amplifier functions of Zone 2 or Zone 3.

See the following pages for details about other controls and functions.

- AM/FM tuning ..... see page 56
- XM Satellite Radio tuning ..... see page 64

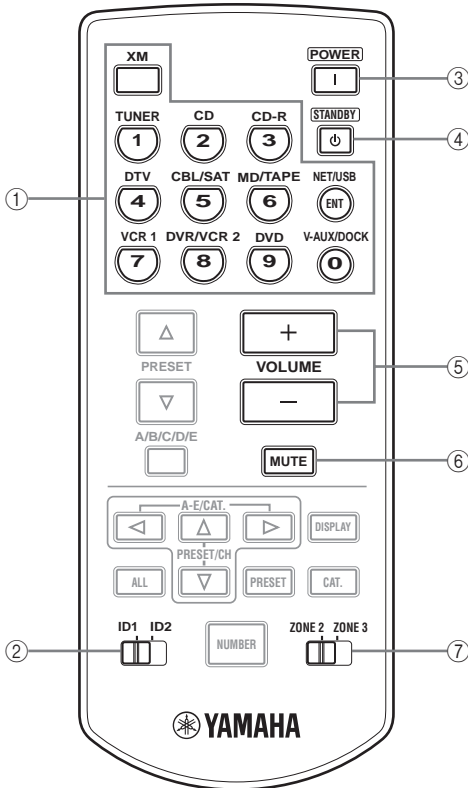

(U.S.A. model)

### ① Input selector buttons

Select the desired input source of Zone 2 or Zone 3.

### ② ID1/ID2 switch

Switches the remote control ID between ID1 and ID2 (see page 121).

### ③ POWER

Turns on Zone 2 or Zone 3.

### Note

This button is operational only when MASTER ON/OFF on the front panel is pressed inward to the ON position.

### ④ STANDBY

Sets Zone 2 or Zone 3 to the standby mode.

### Note

This button is operational only when MASTER ON/OFF on the front panel is pressed inward to the ON position.

### ⑤ VOLUME +/-

Increases or decreases the volume level of Zone 2 or Zone 3.

### ⑥ MUTE

Mutes the sound of Zone 2 or Zone 3. Press again to restore the audio output to the previous volume level.

### ⑦ ZONE 2/ZONE 3 switch

Switches between the operation mode of Zone 2 and that of Zone 3.

## Preparing the remote control

### ■ Installing batteries in the remote control

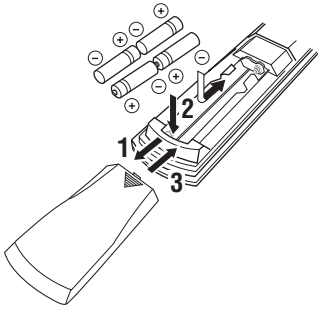

**1** Press the ▼ part and slide the battery compartment cover off.

**2** Insert the four supplied batteries (AAA, LR03) according to the polarity markings (+ and -) on the inside of the battery compartment.

**3** Slide the cover back until it snaps into place.

### ■ Installing batteries in the Zone 2/Zone 3 remote control

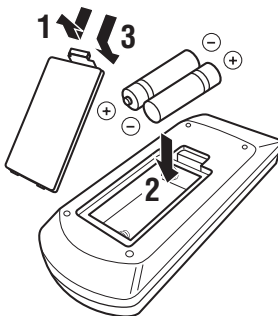

**1** Take off the battery compartment cover.

**2** Insert the two supplied batteries (AAA, LR03) according to the polarity markings (+ and -) on the inside of the battery compartment.

**3** Snap the battery compartment cover back into place.

### Notes

- Change all of the batteries if you notice the following conditions:
  - the operation range of the remote control decreases.
  - the TRANSMIT indicator does not flash or its light becomes dim.
- Do not use old batteries together with new ones.
- Do not use different types of batteries (such as alkaline and manganese batteries) together. Read the packaging carefully as these different types of batteries may have the same shape and color.
- We strongly recommend using alkaline batteries.
- If the batteries have leaked, dispose of them immediately. Avoid touching the leaked material or letting it come into contact with clothing, etc. Clean the battery compartment thoroughly before installing new batteries.
- Do not throw away batteries with general house waste; dispose of them correctly in accordance with your local regulations.
- If the remote control is without batteries for more than 2 minutes, or if exhausted batteries remain in the remote control, the contents of the memory may be cleared. When the memory is cleared, insert new batteries, set up the remote control code and program any acquired functions that may have been cleared.

### ■ Using the remote control

The remote control transmits a directional infrared ray. Be sure to aim the remote control directly at the remote control sensor on this unit during operation.

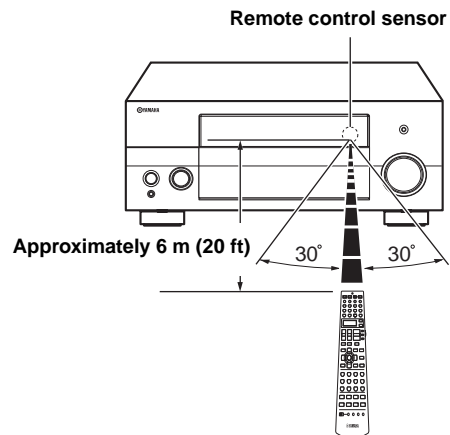

### Notes

- Do not spill water or other liquids on the remote control.
- Do not drop the remote control.
- Do not leave or store the remote control in the following types of conditions:
  - places of high humidity, such as near a bath
  - places of high temperatures, such as near a heater or stove
  - places of extremely low temperatures
  - dusty places

# Front panel display

**Note**

The XM indicator is only applicable to the U.S.A. and Canada models and the cursor on the left of the XM indicator lights up only when “XM” is selected as the input source. For details, see “Basic XM Satellite Radio operations” on page 67.

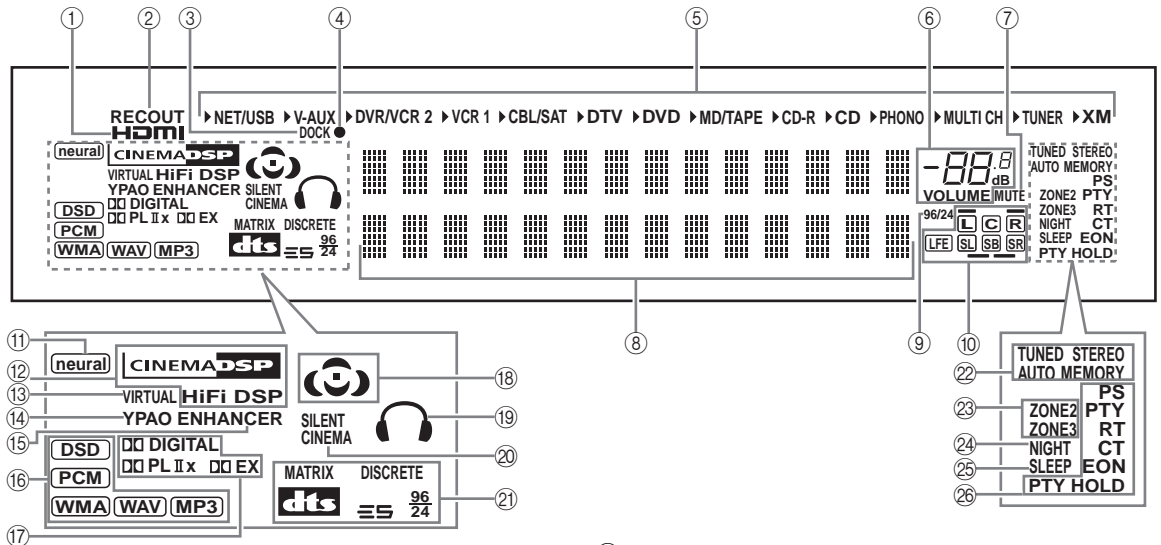

⑪ ..... U.S.A. and Canada models only

⑳ ..... U.K. and Europe models only

① **HDMI indicator**

Lights up when the signal of the selected input source is input at HDMI IN 1, HDMI IN 2 or HDMI IN 3 jacks (see page 21).

② **RECOUT indicator**

Lights up when this unit is in the recording input source selecting mode (see page 83).

③ **DOCK indicator**

Lights up when you station your iPod in a YAMAHA iPod universal dock (such as the YDS-10, sold separately) connected to the DOCK terminal of this unit (see page 29).

④ **Battery charge indicator**

Lights up when this unit charges the battery of the stationed iPod in the standby mode of this unit (see page 75).

⑤ **Input source indicators**

The corresponding cursor lights up to show the currently selected input source.

⑥ **VOLUME level indicator**

Indicates the current volume level.

⑦ **MUTE indicator**

Flashes while the MUTE function is on (see page 43).

⑧ **Multi-information display**

Shows the name of the current sound field program and other information when adjusting or changing settings.

⑨ **96/24 indicator**

Lights up when a DTS 96/24 signal is input to this unit.

⑩ **Input channel and speaker indicators**

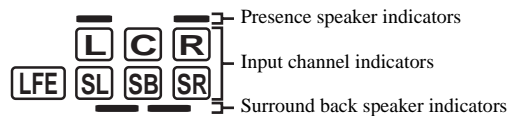

**Input channel indicators**

Indicate the channel components of the current digital input signal.

**Presence and surround back speaker indicators**

Light up according to the number of presence and surround back speakers set for “Presence” (see page 106) and “Surround Back” (see page 106) in “Speaker Set” when “Test Tone” in “Basic” is set to “ON” (see page 105).



You can make settings for the presence and surround back speakers automatically by running “Auto Setup” (see page 35) or manually by adjusting settings for “Presence” (see page 106) and “Surround Back” (see page 106) in “Speaker Set”.



**⑪ neural indicator****(U.S.A. and Canada models only)**

Lights up when the Neural Surround decoder is activated (see page 85).

**⑫ DSP indicators**

The respective indicator lights up when any of the DSP sound field programs are selected.

**CINEMA DSP indicator**

Lights up when you select a CINEMA DSP sound field program (see page 47).

**HiFi DSP indicator**

Lights up when you select a HiFi DSP sound field program (see page 47).

**⑬ VIRTUAL indicator**

Lights up when Virtual CINEMA DSP is active (see page 51).

**⑭ YPAO indicator**

Lights up when you run “Auto Setup” and when the speaker settings set in “Auto Setup” are used without any modifications (see page 35).

**⑮ ENHANCER indicator**

Lights up when the Compressed Music Enhancer mode is turned on (see page 54).

**⑯ Signal format indicators**

The respective indicator lights up when this unit is reproducing DSD (Direct Stream Digital), PCM (Pulse Code Modulation), WMA (Windows Media Audio), WAV (RIFF Wave Form Audio) or MP3 (MPEG-1 Audio Layer-3) audio signals.

**⑰ Dolby decoder indicators**

The respective indicator lights up when any of the Dolby decoders of this unit function.

**⑱ Sound field indicators**

Light up to indicate the active DSP sound fields.

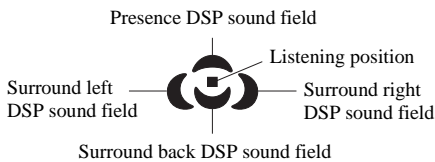
**⑲ Headphones indicator**

Lights up when headphones are connected (see page 43).

**⑳ SILENT CINEMA indicator**

Lights up when headphones are connected and a sound field program is selected (see page 51).

**㉑ DTS decoder indicators**

The respective indicator lights up when any of the DTS decoders of this unit function.

**㉒ Tuner indicators**

Lights up when this unit is in the FM, AM or XM Satellite Radio tuning mode.

**TUNED indicator**

Lights up when this unit is tuned into a station (see page 56).

**STEREO indicator**

Lights up when this unit is receiving a strong signal for an FM stereo broadcast while the AUTO indicator is lit (see page 56).

**AUTO indicator**

Lights up when this unit is in the automatic tuning mode (see page 56).

**MEMORY indicator**

Flashes to show that a station can be stored (see page 59).

**㉓ ZONE2/ZONE3 indicators**

Lights up when Zone 2 or Zone 3 is turned on (see page 131).

**㉔ NIGHT indicator**

Lights up when you select a night listening mode (see page 55).

**㉕ SLEEP indicator**

Lights up while the sleep timer is on (see page 45).

**㉖ Radio Data System indicators (U.K. and Europe models only)****PS, PTY, RT and CT**

Light up according to the selected Radio Data System display mode.

**EON**

Lights up when the EON data service is being received.

**PTY HOLD**

Lights up while searching for the Radio Data System stations in the PTY SEEK mode.



# CONNECTIONS

## Placing speakers

The speaker layout below shows the speaker setting we recommend. You can use it to enjoy CINEMA DSP and multi-channel audio sources.

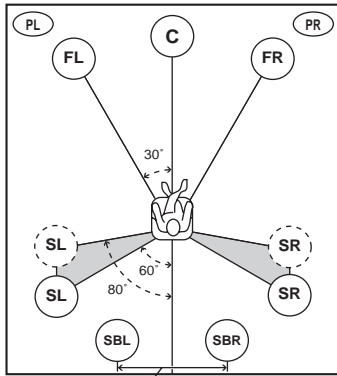

30 cm (12 in) or more

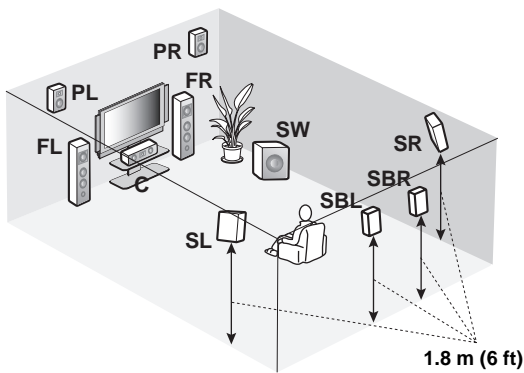

1.8 m (6 ft)

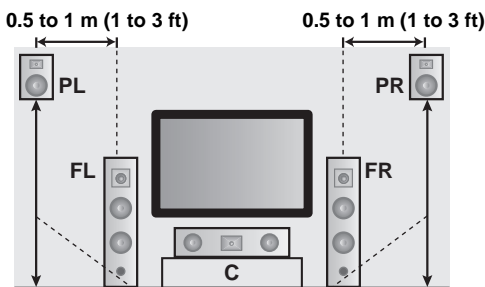

1.8 m (6 ft)

### Front left and right speakers (FL and FR)

The front speakers are used for the main source sound plus effect sounds. Place these speakers at an equal distance from the ideal listening position. The distance of each speaker from each side of the video monitor should be the same.

### Center speaker (C)

The center speaker is for the center channel sounds (dialog, vocals, etc.). If for some reason it is not practical to use a center speaker, you can do without it. Best results, however, are obtained with the full system. Place the center speaker centrally between the front speakers and as close to the monitor as possible, such as directly over or under it.

### Surround left and right speakers (SL and SR)

The surround speakers are used for effect and surround sounds. Place these speakers behind your listening position, facing slightly inwards, about 1.8 m (6 ft) above the floor.

### Surround back left and right speakers (SBL and SBR)

The surround back speakers supplement the surround speakers and provide more realistic front-to-back transitions. Place these speakers directly behind the listening position and at the same height as the surround speakers. They should be positioned at least 30 cm (12 in) apart. Ideally, they should be positioned at the same width as that of the front speakers.

### Presence left and right speakers (PL and PR)

The presence speakers supplement the sound from the front speakers with extra ambient effects produced by CINEMA DSP (see page 153). These effects include sounds that filmmakers intend to locate a little farther back behind the screen in order to create more theater-like ambience. Place these speakers at the front of the room about 0.5 to 1 m (1 to 3 ft) outside the front speakers, facing slightly inward, and about 1.8 m (6 ft) above the floor.

### Subwoofer (SW)

The use of a subwoofer with a built-in amplifier, such as the YAMAHA Active Servo Processing Subwoofer System, is effective not only for reinforcing bass frequencies from any or all channels, but also for high fidelity sound reproduction of the LFE (low-frequency effect) channel included in Dolby Digital and DTS sources. The position of the subwoofer is not so critical, because low bass sounds are not highly directional. But it is better to place the subwoofer near the front speakers. Turn it slightly toward the center of the room to reduce wall reflections.

## Connecting speakers

Be sure to connect the left channel (L), right channel (R), “+” (red) and “-” (black) properly. If the connections are faulty, no sound will be heard from the speakers, and if the polarity of the speaker connections is incorrect, the sound will be unnatural and lack bass.

### CAUTION

- Before connecting the speakers, make sure that this unit is turned off (see page 34).
- Do not let the bare speaker wires touch each other or do not let them touch any metal part of this unit. This could damage this unit and/or speakers.
- Use magnetically shielded speakers. If this type of speaker still creates interference with the monitor, place the speakers away from the monitor.
- If you are to use 6 ohm speakers, be sure to set “SPEAKER IMP.” to “6ΩMIN” before using this unit (see page 33). 4 ohm speakers can be also used as the front speakers (see page 135).

### Notes

- A speaker cord is actually a pair of insulated cables running side by side. Cables are colored or shaped differently, perhaps with a stripe, groove or ridge. Connect the striped (grooved, etc.) cable to the “+” (red) terminals of this unit and your speaker. Connect the plain cable to the “-” (black) terminals.
- The low-frequency signals of other speakers set to “Small” or to “None” in “Speaker Set” (see pages 105 and 106) are directed to the speakers selected in “Bass Out” (see page 107).
- You can connect both surround back and presence speakers to this unit, however they do not output sound simultaneously. You can set to prioritize either set of speakers using the “PR/SB Priority” parameter in “Audio Option” (see page 101).
- You can use the PRESENCE terminals to connect the Zone 2 or Zone 3 speakers as well as the presence speakers (see page 130).

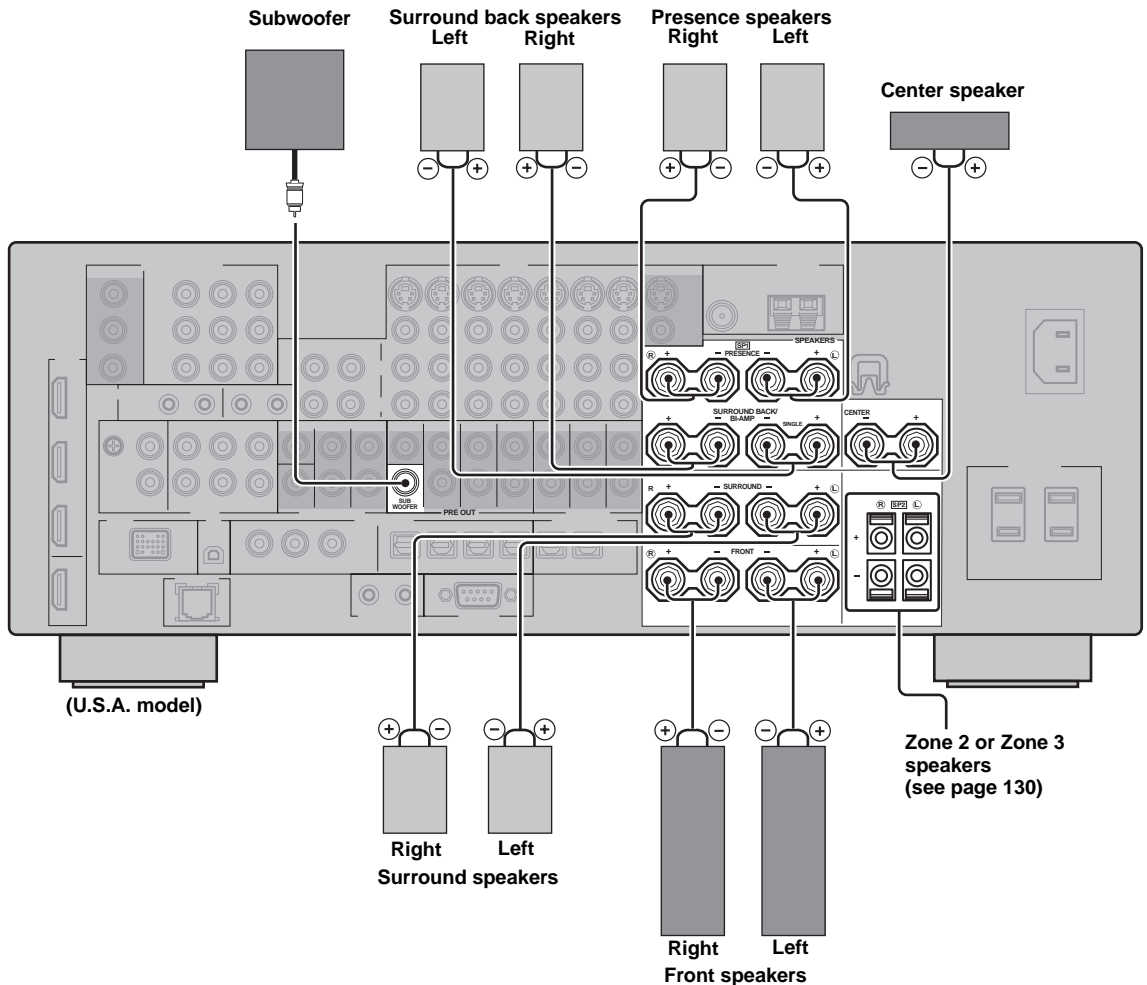

**FRONT terminals**

Connect front left and right speakers to these terminals.

**CENTER terminals**

Connect a center speaker to these terminals.

**SURROUND terminals**

Connect surround left and right speakers to these terminals.

**SURROUND BACK terminals**

Connect surround back left and right speakers to these terminals.

**Note**

When you use a surround back speaker, connect the speaker to the left SURROUND BACK terminal (SINGLE).

**PRESENCE terminals**

Connect presence left and right speakers to these terminals.

**SUBWOOFER jack**

Connect a subwoofer with a built-in amplifier (such as the YAMAHA Active Servo Processing Subwoofer System) to this jack.

■ **Connecting the speaker cable**

- 1 Remove approximately 10 mm (0.4 in) of insulation from the end of each speaker cable and then twist the exposed wires of the cable together to prevent short circuits.

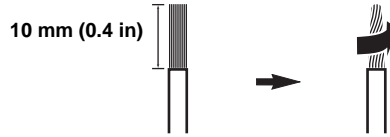

- 2 Loosen the knob using the supplied speaker terminal wrench.

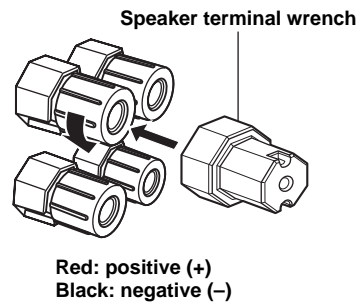

- 3 Insert one bare wire into the hole on the side of each terminal.

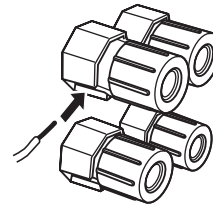

- 4 Tighten the knob to secure the wire using the supplied speaker terminal wrench.

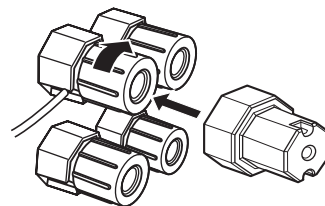

- 5** Hook the speaker terminal wrench onto the **WRENCH HOLDER** on the rear panel of this unit when not in use.

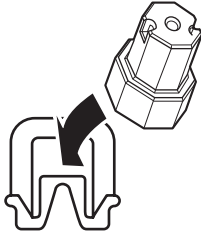

■ **Connecting to the SP2 speaker terminals**

Connect Zone 2 or Zone 3 speakers to these terminals (see page 130).

- 1** Open the tab.

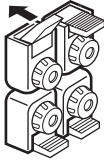

Red: positive (+)  
Black: negative (-)

- 2** Insert one bare wire into the hole on the terminal.

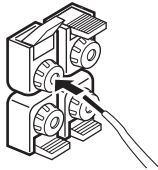

- 3** Close the tab to secure the wire.

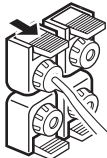

■ **Connecting the banana plug (except U.K., Europe, Asia and Korea models)**

The banana plug is a single-pole electrical connector widely used to terminate speaker cables.

Banana plug

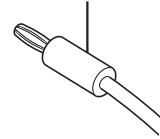

- 1** Tighten the knob using the supplied speaker terminal wrench.

Speaker terminal wrench

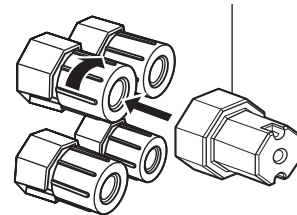

Red: positive (+)  
Black: negative (-)

- 2** Insert the banana plug connector into the end of the corresponding terminal.

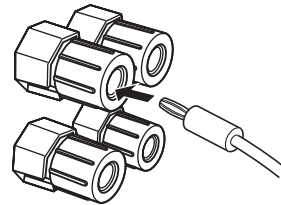

You can also use the banana plug with the SP2 speaker terminals. Open the tab and then insert one banana plug into the hole on the terminal. Do not close the tab after connecting the banana plug.

## Using bi-amplification connections

Some of the speakers have speaker wire connections that allow bi-amplification to enhance the performance of the speaker system. This unit allows you to make bi-amplification connection to one speaker system. Check if your speakers support bi-amplification. As these speakers are shipped to you, you will note shorting bars or bridges, one connecting the two red input terminals and the other connecting the two black input terminals. Remove these shorting bars or bridges only if you plan to bi-amplify your speakers.

### Conventional connection

If you want to connect your speakers as traditional loudspeakers using the conventional connection method, connect your speakers using the regular left and right speaker wire connections and ignore the second set of terminals.

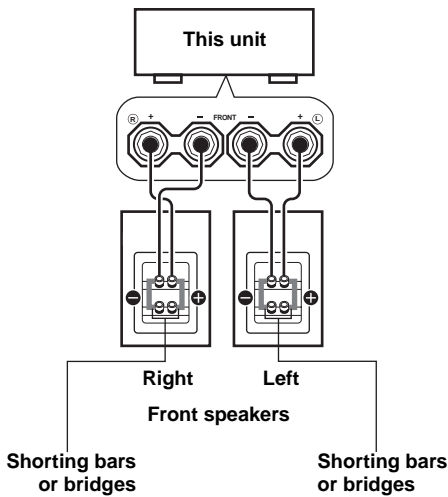

### Bi-amplification connection

To make the bi-amplification connections, use the FRONT and SURROUND BACK terminals as shown below. To activate the bi-amplification connections, set "BI-AMP" to "ON" in "ADVANCED SETUP" (see page 136).

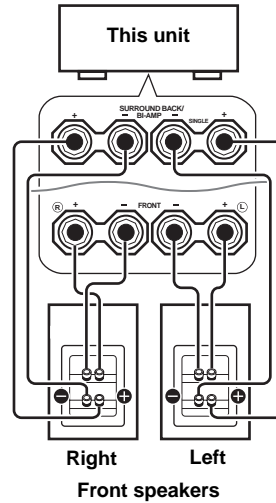

### Note

Remove the shorting bars or bridges to separate the LPF (low pass filter) and HPF (high pass filter) crossovers.

## Information on jacks and cable plugs

### Audio jacks and cable plugs

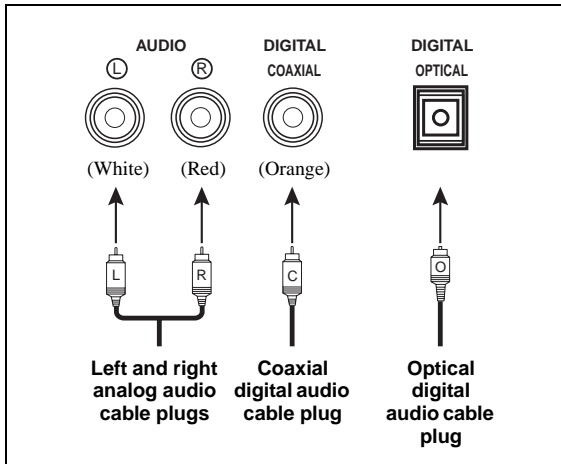

### Video jacks and cable plugs

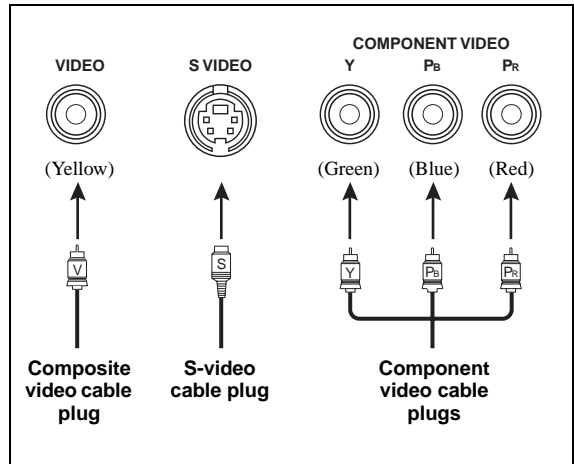

#### ■ Audio jacks

This unit has three types of audio jacks. Connection depends on the availability of audio jacks on your other components.

#### AUDIO jacks

For conventional analog audio signals transmitted via left and right analog audio cables. Connect red plugs to the right jacks and white plugs to the left jacks.

#### DIGITAL COAXIAL jacks

For digital audio signals transmitted via coaxial digital audio cables.

#### DIGITAL OPTICAL jacks

For digital audio signals transmitted via optical digital audio cables.

#### Note

You can use the digital jacks to input PCM, Dolby Digital and DTS bitstreams. When you connect components to both the COAXIAL and OPTICAL jacks, priority is given to the signals input at the COAXIAL jack. All digital input jacks are compatible with 96-kHz sampling digital signals.

#### ■ Video jacks

This unit has three types of video jacks. Connection depends on the availability of input jacks on your video monitor.

#### VIDEO jacks

For conventional composite video signals transmitted via composite video cables.

#### S VIDEO jacks

For S-video signals, separated into the luminance (Y) and chrominance (C) video signals transmitted on separate wires of S-video cables.

#### COMPONENT VIDEO jacks

For component video signals, separated into the luminance (Y) and chrominance (P<sub>B</sub>, P<sub>R</sub>) video signals transmitted on separate wires of component video cables.



This unit equips the video conversion function. See pages 22 and 102 for details.



## Information on HDMI

This unit has the HDMI IN 1, HDMI IN 2, HDMI IN 3 and HDMI OUT jacks for digital audio and video signal input/output. Connect the HDMI IN 1, HDMI IN 2 or HDMI IN 3 jack of this unit to the HDMI output jack of other HDMI components (such as a DVD player). Connect the HDMI OUT jack of this unit to the HDMI IN jack of other HDMI components (such as a TV and a projector).

The video or audio signals input at the HDMI IN 1, HDMI IN 2 or HDMI IN 3 jack of the selected input source are output at the HDMI OUT jack of this unit.

### Note

You can check the potential problem about the HDMI connection (see page 117).

### ■ HDMI compatibility with this unit

Audio signal types	Audio signal formats	Compatible HDMI components
2ch Linear PCM	2ch, 32-192 kHz, 16/20/24 bit	CD, DVD-Video, DVD-Audio, etc.
Multi-ch Linear PCM	8ch, 32-192 kHz, 16/20/24 bit	DVD-Audio, etc.
DSD	2/5.1ch, 2.8224 MHz, 1 bit	SACD, etc.
Bitstream	Dolby Digital, DTS	DVD-Video, etc.

This unit's HDMI interface is based on the following standards:

- HDMI Version 1.2a (High-Definition Multimedia Interface Specification Version 1.2a) licensed by HDMI Licensing, LLC.
- HDCP Revision 1.1 (High-bandwidth Digital Content Protection System Revision 1.1) licensed by Digital Content Protection, LLC.

### Notes

- When CPPM copy-protected DVD audio is played back, video and audio signals may not be output depending on the type of the DVD player.
- This unit is not compatible with HDCP-incompatible HDMI or DVI components.

### ■ HDMI jack and cable plug

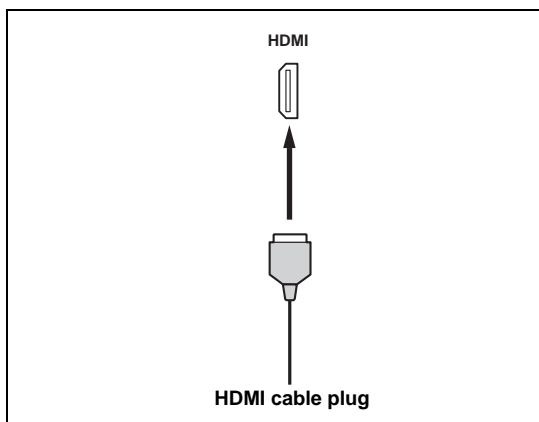

- We recommend using an HDMI cable shorter than 5 meters (16 feet) with the HDMI logo printed on it.
- Use a conversion cable (HDMI jack ↔ DVI-D jack) to connect this unit to other DVI components.

### Notes

- Do not disconnect or connect the cable or turn off the power of the HDMI components connected to the HDMI OUT jack of this unit while data is being transferred. Doing so may disrupt playback or cause noise.
- Audio signals input at input jacks other than the HDMI IN 1, HDMI IN 2 or HDMI IN 3 of this unit cannot be digitally output at the HDMI OUT jack.
- If you turn off the power of the video monitor connected to the HDMI OUT jack via a DVI connection, this unit may fail to establish the connection to the component.
- The analog video signals input at the composite video, S-video and component video jacks can be digitally up-converted to be output at the HDMI OUT jack. Set "Conversion" to "On" in "Video" (see page 102) to activate this feature.

## Audio and video signal flow

### Audio signal flow

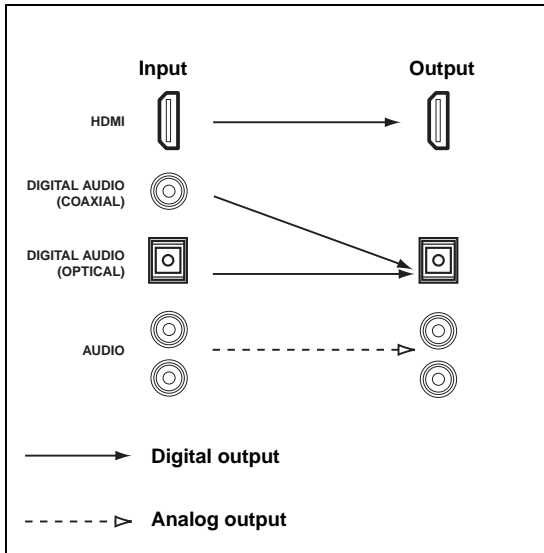

#### Notes

- 2-channel as well as multi-channel PCM, Dolby Digital and DTS signals input at the HDMI IN 1, HDMI IN 2 or HDMI IN 3 jack can be output at the HDMI OUT jack only when "Support Audio" is set to "Other" (see page 115).
- Audio signals input at the HDMI IN jacks are not output at the analog AUDIO OUT and DIGITAL OUTPUT jacks.

### Video signal flow

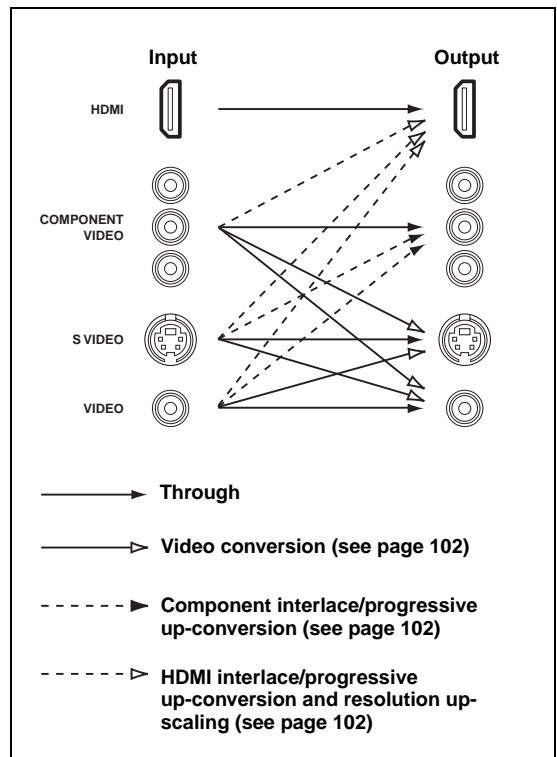

#### Notes

- When the analog video signals are input at the COMPONENT VIDEO, S VIDEO and VIDEO jacks, the priority order of the input signals is as follows:
  1. COMPONENT VIDEO
  2. S VIDEO
  3. VIDEO
- The analog video signals output at the COMPONENT VIDEO jacks can be deinterlaced from 480i (NTSC)/576i (PAL) to 480p/576p. Set "Component I/P" to "On" in "Video" to activate this feature (see page 102).
- Digital video signals input at the HDMI IN 1, HDMI IN 2 or HDMI IN 3 jack cannot be output to analog video output jacks.
- The analog component video signals with 480i (NTSC)/576i (PAL) of resolution are converted to the s-video or composite video signals and output at the S VIDEO MONITOR OUT and VIDEO MONITOR OUT jacks.
- Component interlace/progressive conversion (see page 102) and HDMI up-scaling (see page 102) are available only when "Conversion" is set to "On" (see page 102).
- Use the "HDMI Up-Scaling" parameter in "Video" to deinterlace and convert the resolution of the analog video signals output at the HDMI OUT jack (see page 102).
- The GUI screen signal is not output at the VCR 1 OUT and DVR/VCR 2 OUT jacks and is not recorded.

## Connecting a TV monitor or projector

Connect your TV (or projector) to the HDMI OUT jack, the COMPONENT VIDEO MONITOR OUT jacks, the S VIDEO MONITOR OUT jack or the VIDEO MONITOR OUT jack of this unit.

### CAUTION

**Do not connect this unit or other components to the AC power supply until all connections between components are complete.**

 You can select to play back HDMI audio signals on this unit or on another HDMI component connected to the HDMI OUT jack on the rear panel of this unit. Use the "Support Audio" parameter in "Option" to select the component to play back HDMI audio signals (see page 115).

### Notes

- Some video monitors connected to this unit via a DVI connection fail to recognize the HDMI audio/video signals being input if they are in the standby mode. In this case, the HDMI indicator flashes irregularly.
- Set "Conversion" in "Video" to "On" (see page 102) to display the short message displays.
- Set "Wall Paper" in "Video" to "Yes" or "Gray" (see page 104) to display the parameter displays.
- The GUI screen appears with the wall paper or gray background depending on the input video signal format and the setting of the parameters in "Wall Paper" (see page 104).

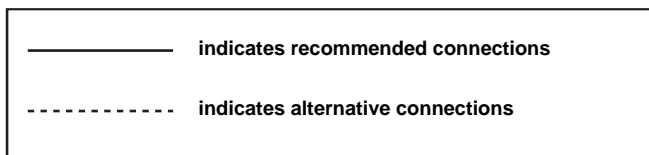
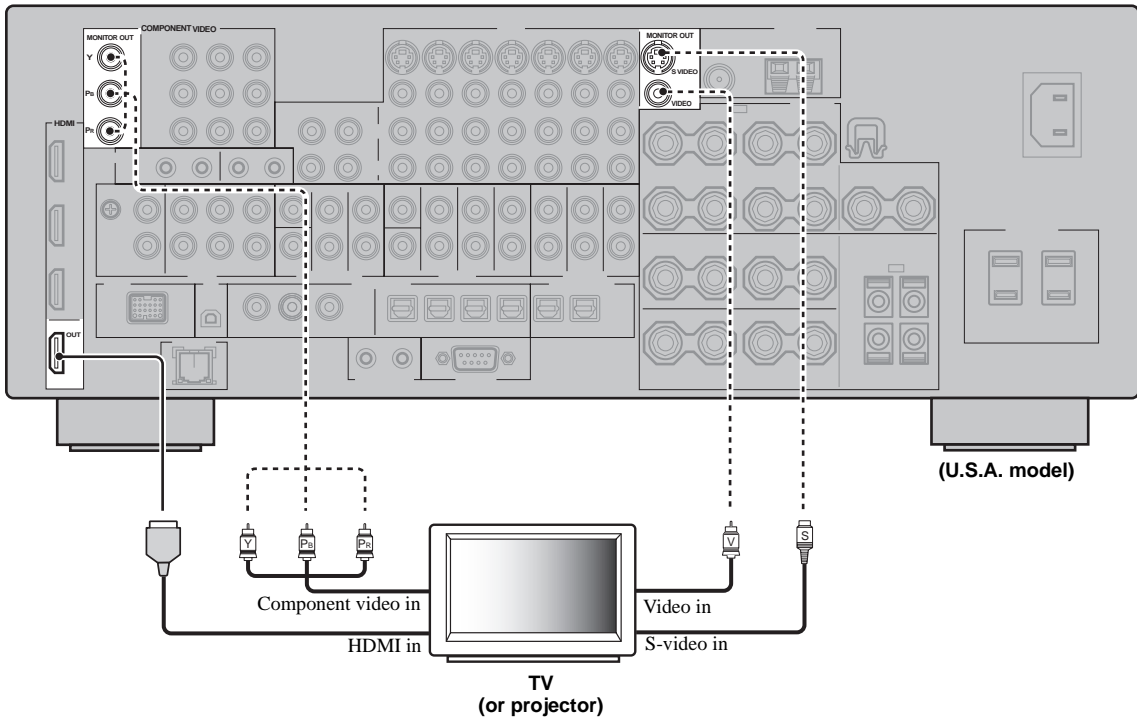

## Connecting other components

### CAUTION

Do not connect this unit or other components to the AC power supply until all connections between components are complete.

### Notes

- When “Conversion” is set to “Off” (see page 102), be sure to make the same type of video connections as those made for your TV (see page 23). For example, if you connected your TV to the VIDEO MONITOR OUT jack of this unit, connect your other components to the VIDEO jacks.
- When “Conversion” is set to “On” (see page 102), the converted video signals are output only at the MONITOR OUT jacks. When recording a source, you must make the same type of video connections between each component.
- To make a digital connection to a component other than the default component assigned to each DIGITAL INPUT or DIGITAL OUTPUT jack, select the corresponding setting for “Option”, “Optical Output”, or “Coaxial Input” in “I/O Assignment” (see page 96).
- If you connect your DVD player to both the DIGITAL INPUT (OPTICAL) and the DIGITAL INPUT (COAXIAL) jacks, priority is given to the signals input at the DIGITAL INPUT (COAXIAL) jack.
- The short message display does not appear when the component video signals with 720p, 1080i or 1080p resolutions are input.
- The short message display does not appear when the component video signals with 480p/576p resolutions are input and output at the VIDEO or S VIDEO MONITOR OUT jack.

### ■ Connecting a DVD player

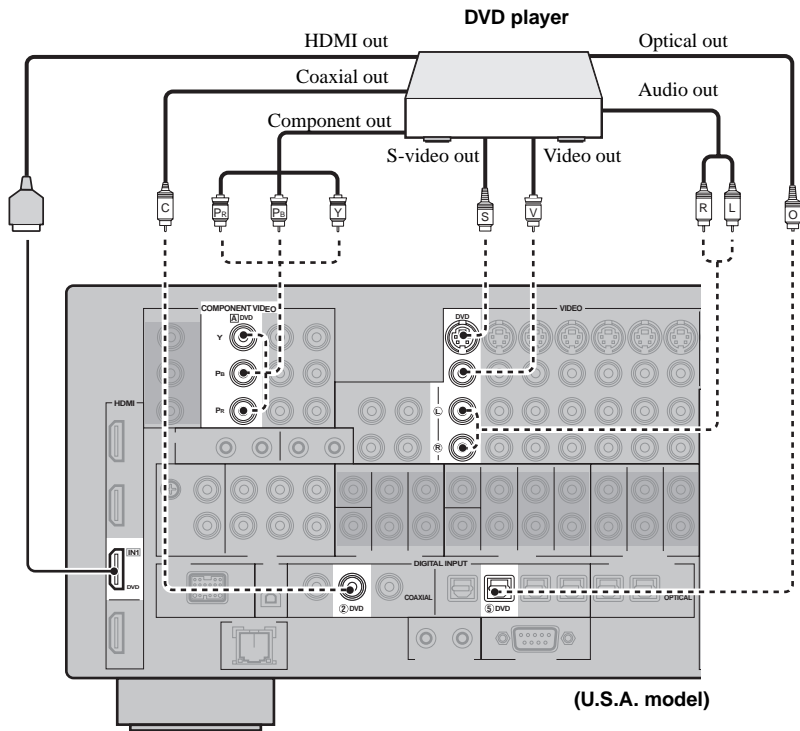

■ Connecting a DVD recorder, PVR or VCR

**Note**

\*1 When you connect another VCR to this unit, connect it to the VCR 1 terminals (S VIDEO IN, VIDEO IN, AUDIO IN, S VIDEO OUT, VIDEO OUT and AUDIO OUT jacks) same as DVR/VCR 2 terminals except the DIGITAL INPUT (COAXIAL) jack.

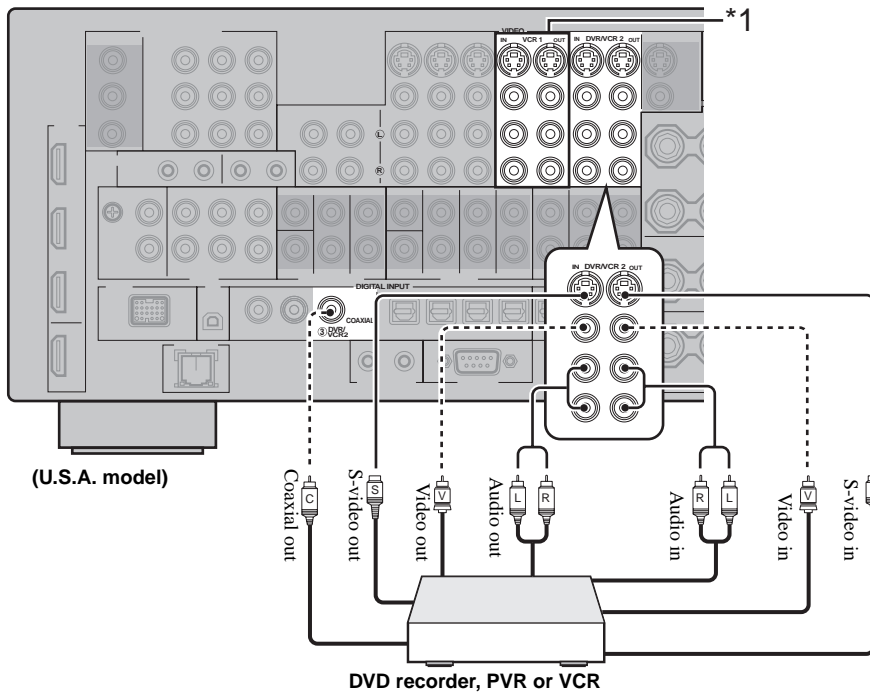

■ Connecting set-top boxes

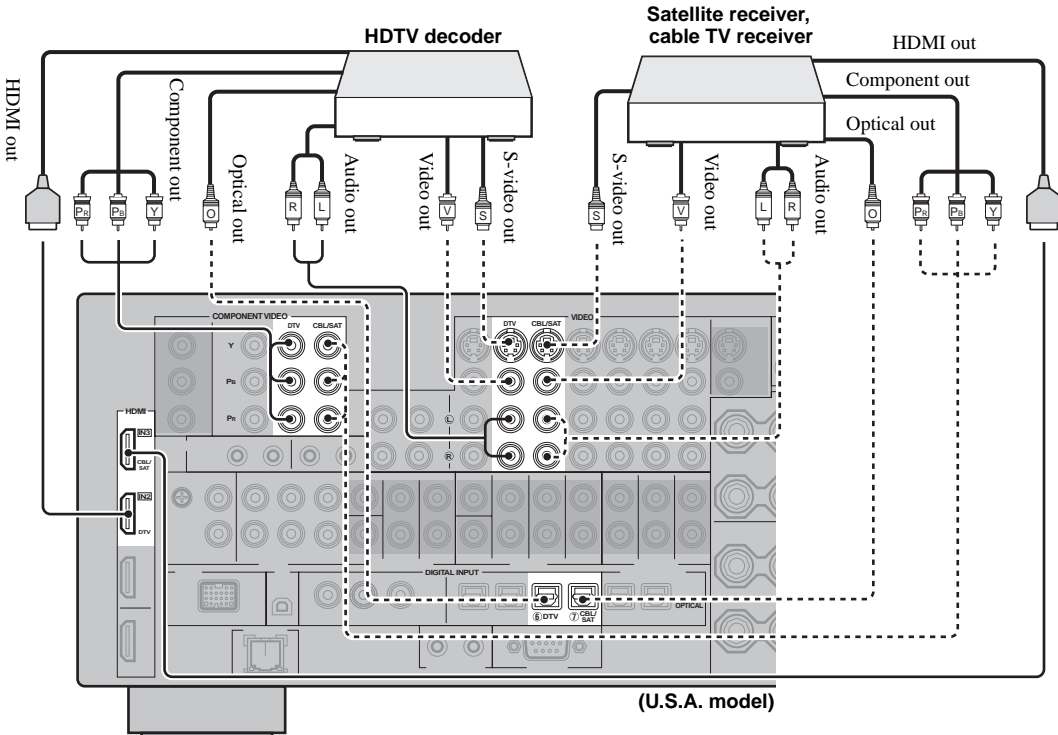

## ■ Connecting audio components

### Notes

- To make a digital connection to a component other than the default component assigned to either the DIGITAL INPUT jack or the DIGITAL OUTPUT jack, select the corresponding setting for “Option”, “Optical Output”, or “Coaxial Input” in “I/O Assignment” (see page 96).
- Connect your turntable to the GND terminal of this unit to reduce noise in the signal. However, you may hear less noise without the connection to the GND terminal for some turntables.
- The PHONO jacks are only compatible with a turntable with an MM or a high-output MC cartridge. To connect a turntable with a low-output MC cartridge to the PHONO jacks, use an in-line boosting transformer or an MC-head amplifier.
- When you connect both the DIGITAL INPUT (OPTICAL) jack and the DIGITAL INPUT (COAXIAL) jack to an audio component, the priority is given to the DIGITAL INPUT (COAXIAL) jack.

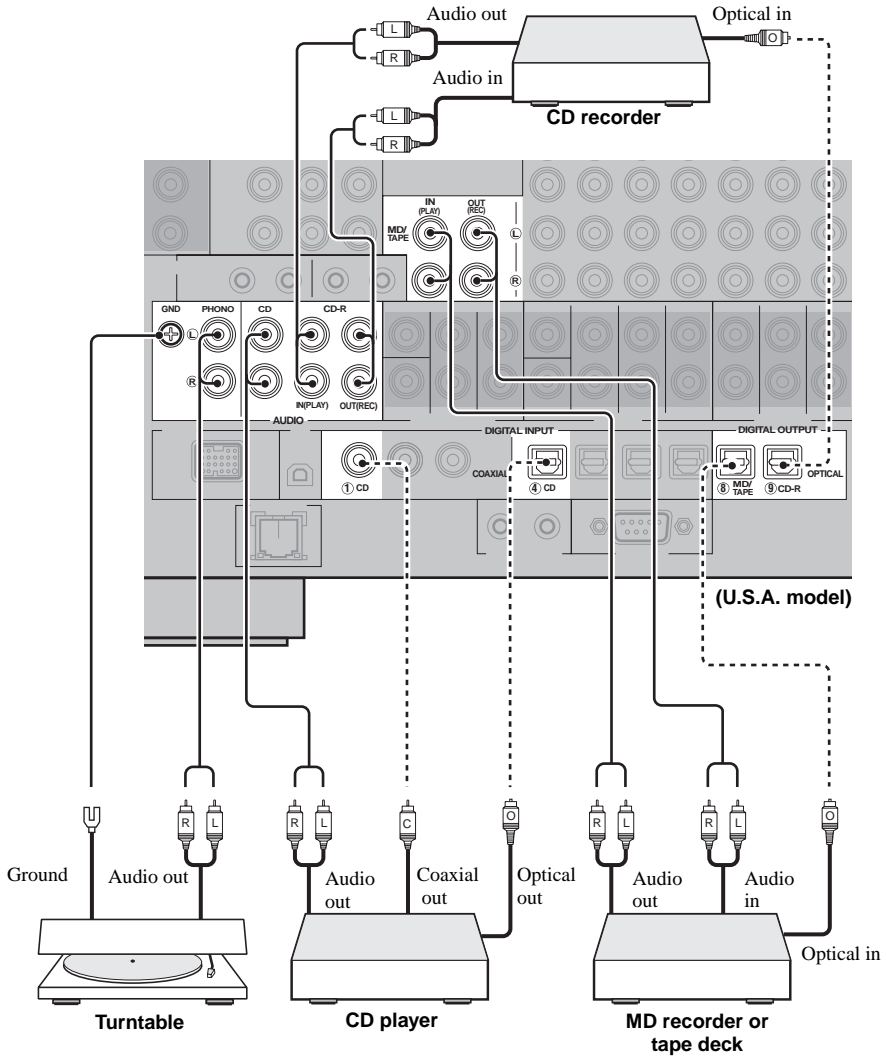

## ■ Connecting an external amplifier

This unit has more than enough power for any home use. However, if you want to add more power to the speaker output or if you want to use another amplifier, connect an external amplifier to the PRE OUT jacks.

### Notes

- When you make connections to the PRE OUT jacks, do not make connections to the SPEAKERS terminals.
- The signals output at the FRONT PRE OUT and CENTER PRE OUT jacks are affected by the TONE CONTROL settings (see page 52).
- Each PRE OUT jack outputs the same channel signals as the corresponding SPEAKERS terminals.
- Adjust the volume level of the subwoofer with the control on the subwoofer (see page 53).
- Some signals may not be output at the SUBWOOFER PRE OUT jack depending on the settings for “Speaker Set” (see page 105) and “Bass Out” (see page 107).

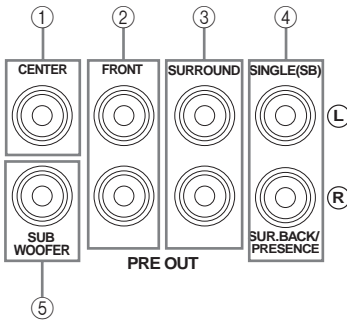

#### ① CENTER PRE OUT jack

Center channel output jack.

#### ② FRONT PRE OUT jacks

Front channel output jacks.

#### ③ SURROUND PRE OUT jacks

Surround channel output jacks.

#### ④ SURROUND BACK/PRESENCE PRE OUT jacks

Surround back or presence channel output jacks. When you only connect one external amplifier for the surround back channel, connect it to the SINGLE (SB) jack.



- Set the “Surround Back” to “Large x2”, “Large x1”, “Small x2” or “Small x1” and “Presence” to “None” (see page 106) to output the surround back channel signals at SURROUND BACK/PRESENCE PRE OUT jacks.
- Set the “Presence” to “Yes” and “Surround Back” to “None” (see page 106) to output the presence channel signals at SURROUND BACK/PRESENCE PRE OUT jacks.

#### ⑤ SUBWOOFER PRE OUT jack

Connect a subwoofer with a built-in amplifier.

## Connecting a multi-format player or an external decoder

This unit is equipped with 6 additional input jacks (left and right FRONT, CENTER, left and right SURROUND and SUBWOOFER) for discrete multi-channel input from a multi-format player, external decoder, sound processor or pre-amplifier.

If you set “Input Channels” to “8ch” in “MULTI CH” (see page 97), you can use the input jacks assigned as “Front Input” in “Multi CH Assign” (see page 97) together with the MULTI CH INPUT jacks to input 8-channel signals. Connect the output jacks on your multi-format player or external decoder to the MULTI CH INPUT jacks. Be sure to match the left and right outputs to the left and right input jacks for the front and surround channels.

### Notes

- When you select the component connected to the MULTI CH INPUT jacks as the input source (see page 43), this unit automatically turns off the digital sound field processor, and you cannot select sound field programs.
- This unit does not redirect signals input at the MULTI CH INPUT jacks to accommodate for missing speakers. We recommend that you connect at least a 5.1-channel speaker system before using this feature.

For 6-channel input

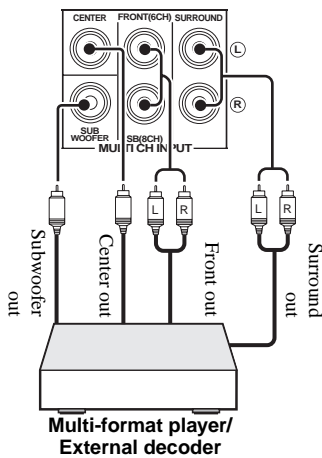

For 8-channel input

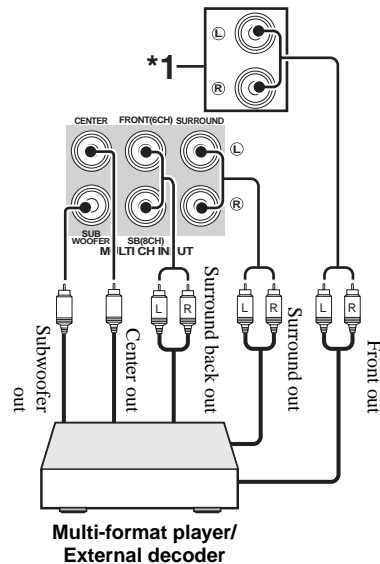

### Note

\*1 The analog audio input jacks assigned as “Front Input” in “Multi CH Assign” (see page 97).



## Connecting a YAMAHA iPod universal dock

This unit is equipped with the DOCK terminal on the rear panel that allows you to connect a YAMAHA iPod universal dock (such as the YDS-10, sold separately) where you can station your iPod and control playback of your iPod using the supplied remote control. Connect a YAMAHA iPod universal dock (such as the YDS-10, sold separately) to the DOCK terminal on the rear panel of this unit using its dedicated cable.

### CAUTION

**Do not connect this unit to the AC power supply until all connections between components are complete.**

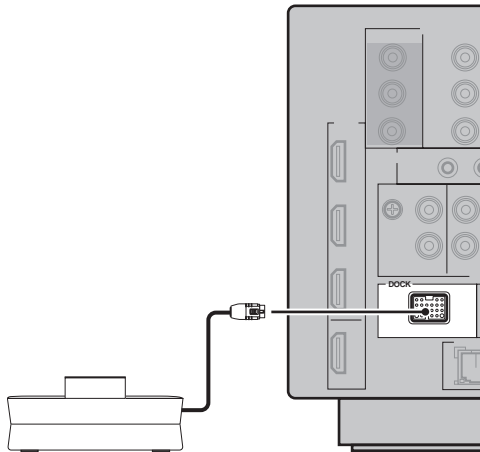

YAMAHA iPod universal dock (such as the YDS-10, sold separately)

## Using the VIDEO AUX jacks on the front panel

Use the VIDEO AUX jacks on the front panel to connect a game console or a video camera to this unit.

### CAUTION

**Be sure to turn off the volume of this unit and other components before making connections.**

### Note

The audio signals input at the DOCK terminal on the rear panel take priority over the ones input at the VIDEO AUX jacks.

(U.S.A. model)

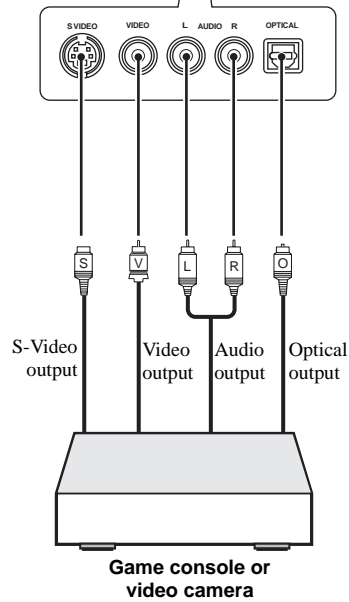
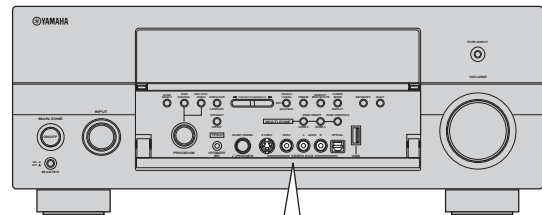

## Connecting the network

To connect this unit to your network, plug one end of a network cable (CAT-5 or higher straight cable) into the NETWORK port of this unit, and plug the other end into one of the LAN ports on your router that supports the DHCP (Dynamic Host Configuration Protocol) server function. The following diagram shows a connection example where this unit is connected to one of the LAN ports on a 4-port router. To enjoy music files saved on your PC and YAMAHA MCX-2000 or access the Internet Radio, each device must be connected properly in the network.

### Note

If the DHCP server function on your router is disabled, you need to configure the network settings manually (see page 109).

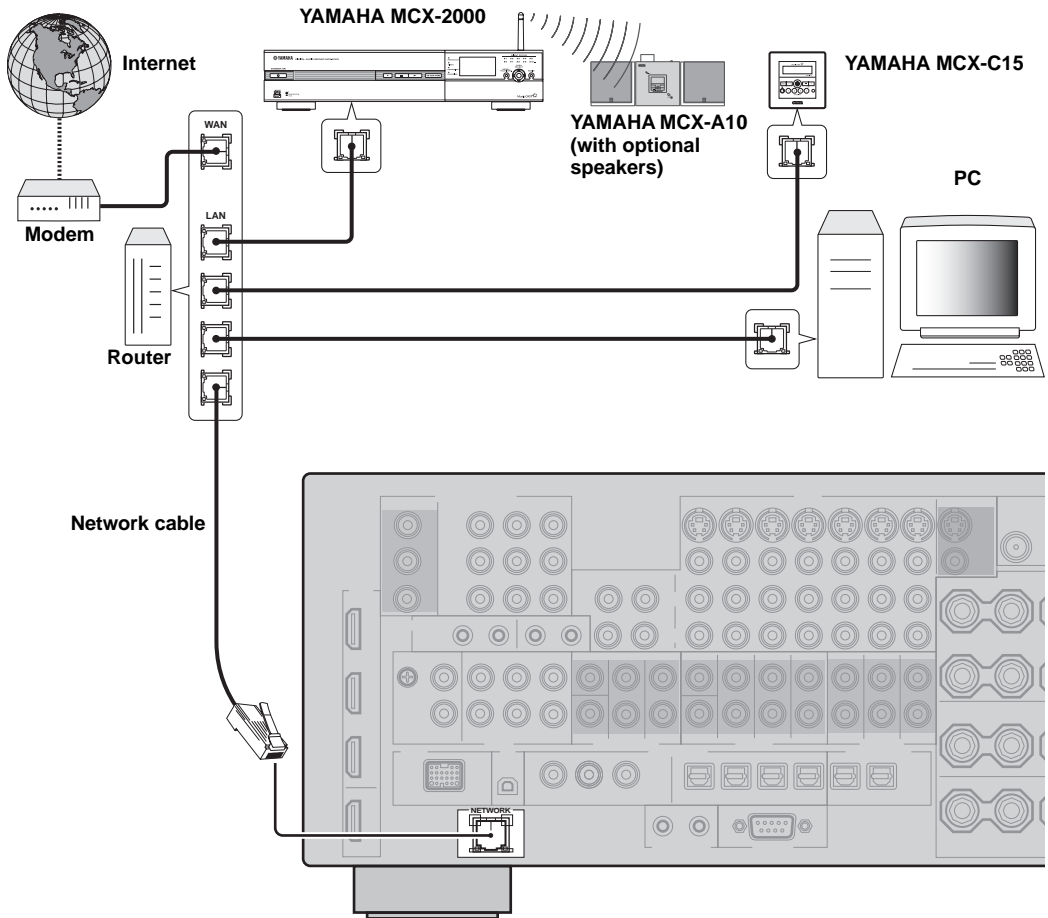

## Connecting the FM and AM antennas

Both FM and AM indoor antennas are supplied with this unit. Connect each antenna correctly to the designated terminals. In general, these antennas should provide sufficient signal strength.

### Notes

- Be sure to set the tuner frequency step (Asia and General models only) according to the frequency spacing in your area (see page 136).
- The AM loop antenna should be placed away from this unit.
- The AM loop antenna should always be connected, even if an outdoor AM antenna is connected to this unit.
- A properly installed outdoor antenna provides clearer reception than an indoor one. If you experience poor reception quality, install an outdoor antenna. Consult the nearest authorized YAMAHA dealer or service center about outdoor antennas.

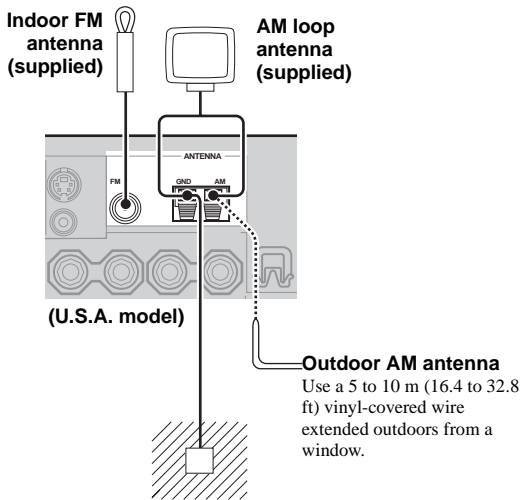

### ■ Connecting the AM loop antenna

**1 Set up the AM loop antenna.**

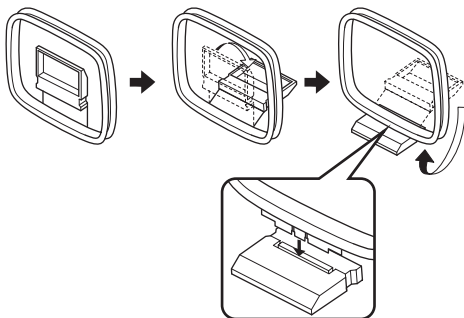

**2 Press and hold the tab of the AM ANT terminal.**

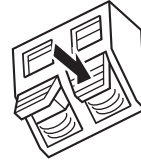

**3 Insert one of the AM loop antenna lead wires into the AM ANT terminal.**

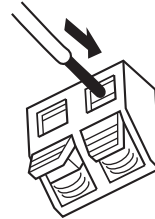

**4 Release the tab of the AM ANT terminal.**

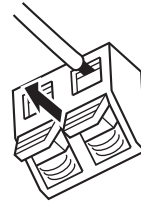

**5 Repeat steps 2 through 4 to connect the other lead wire to the GND terminal.**



Once you have properly connected the AM loop antenna to this unit, orient the AM loop antenna for the best reception when you tune into AM stations (see page 56).

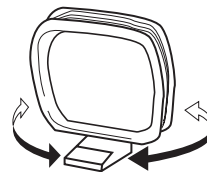

## Connecting the power cable

### ■ Connecting the AC power cable

#### CAUTION

Use the supplied AC cable. Do not use other AC power cables as doing so may result in fire or electrical shock.

Plug the supplied AC power cable into the AC inlet after all other connections are complete, then plug the AC power cable into an AC wall outlet.

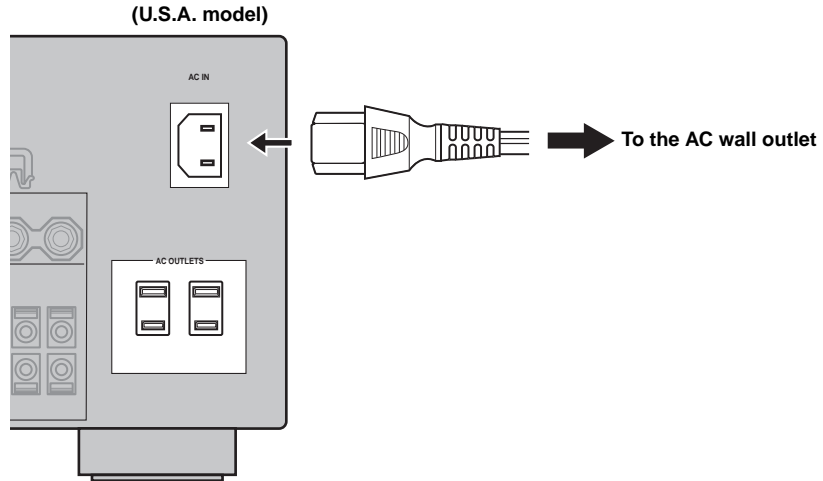

### ■ VOLTAGE SELECTOR (Asia and General models only)

#### CAUTION

The **VOLTAGE SELECTOR** on the rear panel of this unit must be set for your local voltage **BEFORE** plugging the power cable into the AC wall outlet. Improper setting of the **VOLTAGE SELECTOR** may cause damage to this unit and create a potential fire hazard.

Rotate the **VOLTAGE SELECTOR** clockwise or counterclockwise to the correct position using a straight slot screwdriver.

Voltages are as follows:

..... 110/120/220/230–240 V AC, 50/60 Hz

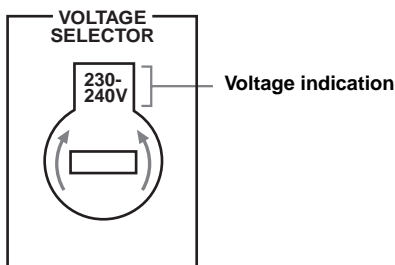

### ■ AC OUTLET(S) (SWITCHED)

U.K. and Australia models..... 1 outlet  
 Korea model..... None  
 Other models..... 2 outlets

Use these outlet(s) to supply power to any connected components. Connect the power cable of your other components to these outlet(s). Power to these outlet(s) is supplied when this unit is turned on. However, power to these outlet(s) is cut off when this unit is turned off. For information on the maximum power or the total power consumption of the components that can be connected to these outlet(s), see “SPECIFICATIONS” on page 155.

#### Memory back-up

The memory back-up circuit prevents the stored data from being lost even if this unit is in the standby mode. However, the stored data will be lost in case the power cable is disconnected from the AC wall outlet or if the power supply is cut off for more than one week.

## Setting the speaker impedance

### CAUTION

If you are to use 6 ohm speakers, set “SPEAKER IMP.” to “6ΩMIN” as follows BEFORE using this unit. 4 ohm speakers can be also used as the front speakers.

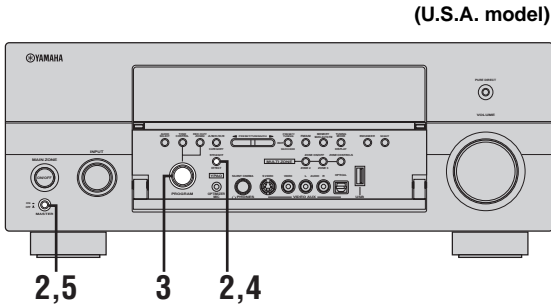

**1** Make sure this unit is turned off.  
See page 34 for details about turning on or off this unit.

**2** Press and hold **STRAIGHT** on the front panel and then press **MASTER ON/OFF** inward to the **ON** position to turn on this unit.  
This unit turns on, and the advanced setup menu appears in the front panel display.



**3** Rotate the **PROGRAM** selector on the front panel to select “**SPEAKER IMP.**”.  
The following display appears in the front panel display.

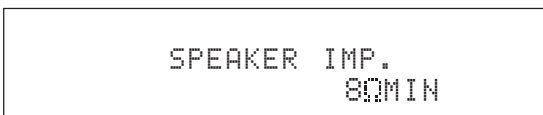

**4** Press **STRAIGHT** on the front panel repeatedly to select “**6ΩMIN**”.  
The following display appears in the front panel display.



**5** Press **MASTER ON/OFF** on the front panel to release it outward to the **OFF** position to save the new setting and turn off this unit.



### Note

The setting you made is reflected next time you turn on this unit.

## Turning on and off the power

When all connections are complete, turn on this unit.

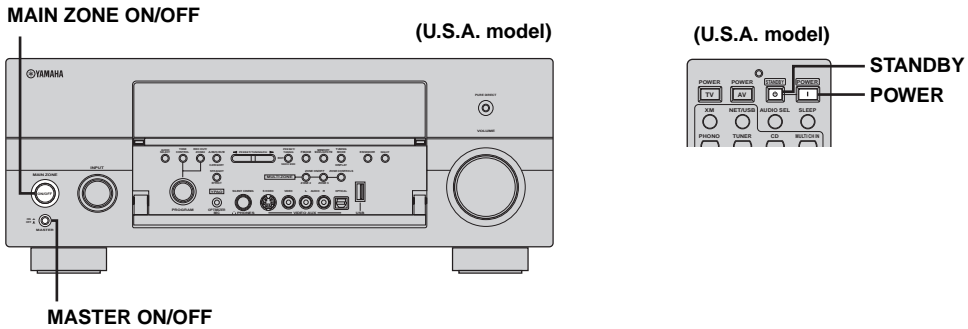

### ■ Turning on this unit

Press **MASTER ON/OFF** on the front panel inward to the **ON** position to turn on this unit.

When you turn on this unit by pressing **MASTER ON/OFF**, the main zone is turned on.



Front panel

### ■ Turning on the main zone from the standby mode

Press **MAIN ZONE ON/OFF** on the front panel (or **POWER** on the remote control) to turn on the main zone.

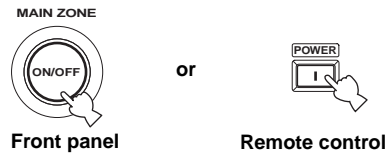

Front panel

Remote control

### ■ Turning off this unit

Press **MASTER ON/OFF** on the front panel again to release it outward to the **OFF** position to turn off this unit.



Front panel

### ■ Set the main zone to the standby mode

Press **MAIN ZONE ON/OFF** on the front panel (or **STANDBY** on the remote control) to set the main zone to the standby mode.

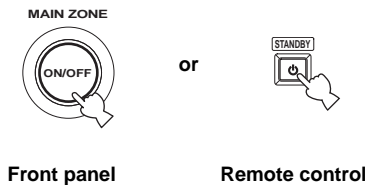

Front panel

Remote control

### Notes

- **MAIN ZONE ON/OFF** on the front panel as well as **POWER** and **STANDBY** on the remote control are operational only when **MASTER ON/OFF** is pressed inward to the **ON** position.
- As usual, we recommend using the standby mode to turn off this unit.

# AUTO SETUP

This unit employs the YPAO (YAMAHA Parametric Room Acoustic Optimizer) technology which lets you avoid troublesome listening-based speaker setup and achieves highly accurate sound adjustments automatically. The supplied optimizer microphone collects and this unit analyzes the sound your speakers produce in your actual listening environment.

## Using Auto Setup

Once you have connected the supplied optimizer microphone to the OPTIMIZER MIC jack on the front panel and have placed it in a suitable location in your listening room, run “Auto Setup” in the GUI screen.

### Notes

- Connect a video monitor to run “Auto Setup” (see page 23).
  - Be advised that it is normal for loud test tones to be output during the “Auto Setup” procedure.
  - To achieve the best results, make sure the room is as quiet as possible while the “Auto Setup” procedure is in progress. If there is too much ambient noise, the results may not be satisfactory.
- ☀
- If an error occurs during the “Auto Setup” procedure and an error or warning message appears in the GUI screen or in the front panel display, see the “Auto Setup” section in “TROUBLESHOOTING” on pages 147 and 148 for a complete list of error and warning messages and proper remedies.
  - The initial setting for each parameter is indicated in **bold**.
  - If the volume level and the crossover frequency of your subwoofer can be adjusted, set the volume level to about half way (or slightly less) and set the crossover frequency to the maximum.

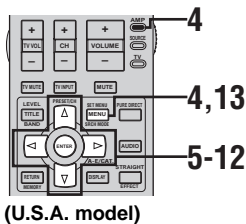

- 1 Connect the supplied optimizer microphone to the OPTIMIZER MIC jack on the front panel.

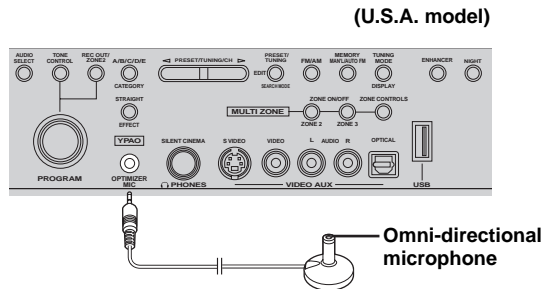

- 2 Place the optimizer microphone at your normal listening position on a flat level surface with the omni-directional microphone heading upward.

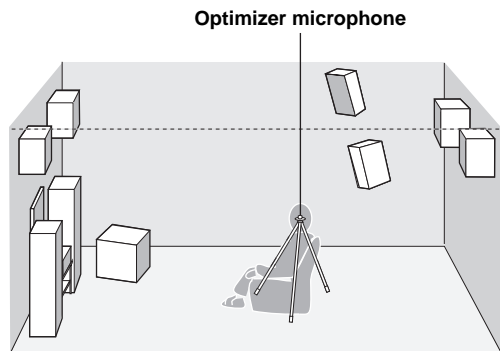

It is recommended that you use a tripod (etc.) to affix the optimizer microphone at the same height as your ears would be when you are seated in your listening position. You can use a 6 mm diameter screw to fix the optimizer microphone to a tripod (etc.).

**3 Make sure of the following check points before starting the Auto Setup operations.**

- Speakers are connected appropriately.
- Supplied optimizer microphone is connected to this unit and placed appropriately.
- Headphones are disconnected from this unit.
- The room is sufficiently quiet.
- The video monitor connected to this unit is turned on.

**4 Set the operation mode selector to AMP and then press SET MENU to turn on the GUI screen.**

The GUI screen appears on the video monitor.

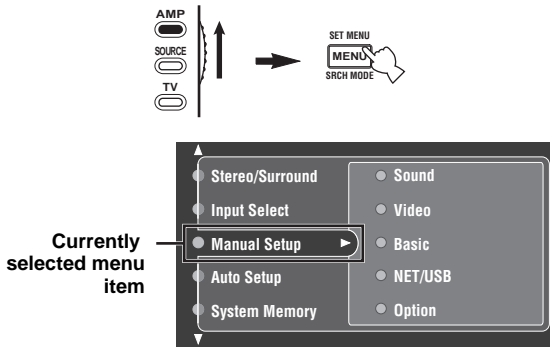

**6 Press  $\triangleright$  to enter "Setup Menu".**

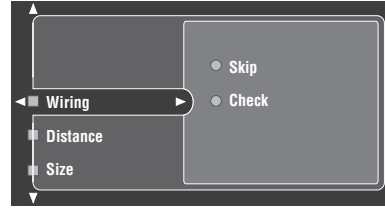

**7 Press  $\Delta$  /  $\nabla$  repeatedly to select "Wiring", "Distance", "Size", "Equalizing", or "Level", and then press  $\triangleright$  to set the selected parameter.**

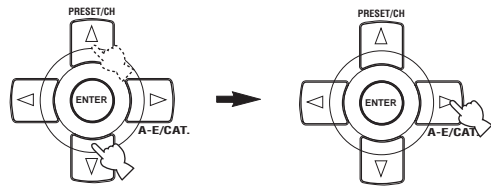

**8 Press  $\Delta$  /  $\nabla$  repeatedly to select the desired parameter and then ENTER to confirm the selection.**

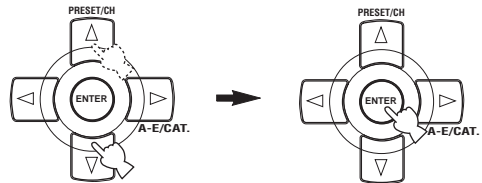

**5 Press  $\Delta$  /  $\nabla$  repeatedly and then  $\triangleright$  to select "Auto Setup".**

"Setup Menu" is selected as the currently selected menu item.

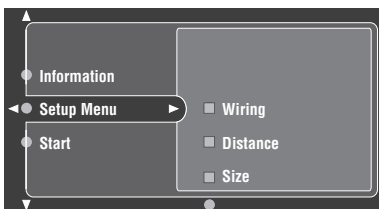
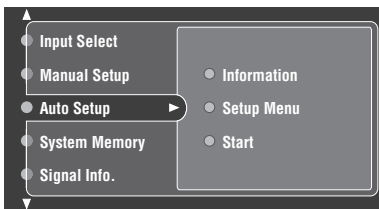
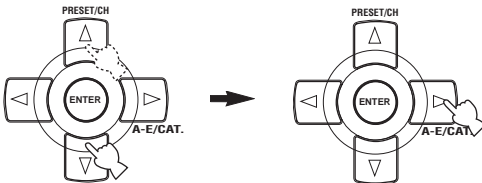



**9 Repeat steps 7 and 8 until you set all the desired parameters.**

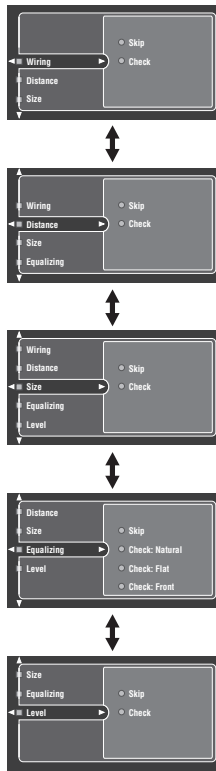

This unit performs the following checks:

**Wiring (Speaker wiring)**

Checks which speakers are connected and the polarity of each speaker.

**Distance (Speaker distance)**

Checks the distance of each speaker from the listening position and adjusts the timing of each channel.

**Size (Speaker size)**

Checks the frequency response of each speaker and sets the appropriate low-frequency crossover for each channel.

Choices: **Check**, Skip

- Select “Check” to automatically check and adjust the item.
- Select “Skip” to skip the item and perform no adjustments.

**Equalizing (Parametric equalizer level)**

Adjusts the frequency and the parametric equalizer level of each channel to reduce coloration across the channels and create a cohesive sound field. This is particularly important if you use different brands or sizes of speakers for some channels or have a room with unique sonic characteristics. In addition, the frequency response of each channel is adjusted in accordance with the sound output from your front speakers.

Choices: **Check:Natural**, Check:Flat, Check:Front, Skip

- Select “Check:Natural” to average out the frequency response of all speakers with higher frequencies being less emphasized. Recommended if the “Check:Flat” setting sounds a little harsh.
- Select “Check:Flat” to average the frequency response of all speakers. Recommended if all of your speakers are of similar quality.
- Select “Check:Front” to adjust the frequency response of each speaker in accordance with the sound of your front speakers. Recommended if your front speakers are of much higher quality than your other speakers.
- Select “Skip” to skip the selected item and perform no adjustments.

**Level (Volume level)**

Checks and adjusts the volume level of each speaker. Choices: **Check**, Skip

- Select “Check” to automatically check and adjust this item.
- Select “Skip” to skip this item and perform no adjustments.

**10 Once you have selected the desired settings of each parameter, press ◀ to return to the previous menu level and then press ▽ to select “Start”.**

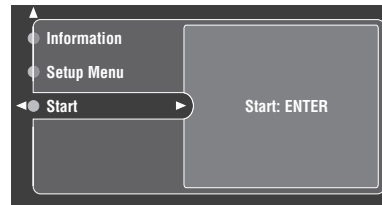

## 11 Press ENTER to start the setup procedure.

This unit starts the auto setup procedure. Loud test tones are output from each speaker during the auto setup procedure. During the setup procedure, “Measuring...” appears in the GUI screen. We recommend getting out of the room while this unit is in the auto setup procedure. The necessary time for the auto setup procedure depends on the environment of the listening room and connected speaker (from 30 seconds to 3 minutes).

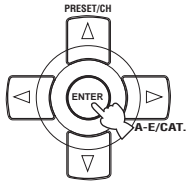

- To stop the Auto Setup procedure and set this unit to the pause mode, press one of the cursor buttons (▲ / ▼ / ◀ / ▶) or ENTER. In the pause mode, press ▲ to retry the procedure, and ◀ to cancel the Auto Setup procedure.
- If an error message appears and this unit stops the setup procedure, see the “Auto Setup” section in “TROUBLESHOOTING” on page 147, and after carrying out the remedy, retry the Auto Setup procedure.

## 12 Once all items are set successfully, following display appears in the GUI screen.

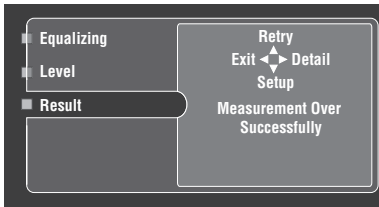

- Press ▼ and select “Setup” to set the measured values.
- Press ▲ and select “Retry” to retry the Auto Setup procedure.
- Press ▶ and select “Detail” to view information about measurement results and warning messages. For more details about warning messages, see the “Auto Setup” section in “TROUBLESHOOTING” on page 147.
- Press ◀ and select “Exit” to exit from the Auto Setup procedure. If you select “Exit”, “Don’t Setup?” appears on the screen. To set the measured values and exit, select “Yes”. To cancel the settings and exit, select “No”.



If you are not satisfied with the results or want to manually adjust each parameter, set the parameters in “Basic” (see page 104).

### Notes

- If you change speakers, speaker positions, or the layout of your listening environment, run “Auto Setup” again to recalibrate your system.
- The distances displayed in the “Distance” results may be longer than the actual distance depending on the characteristics of your subwoofer.
- In the “Equalizing” results, different values may be set for the same band to provide finer adjustments.

## 13 Press SET MENU to exit from the GUI screen.



### Notes

- After you have completed the “Auto Setup” procedure, be sure to disconnect the optimizer microphone.
- The optimizer microphone is sensitive to heat. Keep it away from direct sunlight and do not place it on top of this unit.

### ■ Reviewing the result of the auto setup

Use this feature to review the result of the auto setup.

## 1 Set the operation mode selector to AMP and then press SET MENU to turn on the GUI screen.

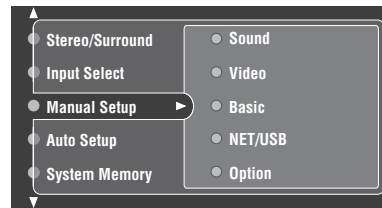
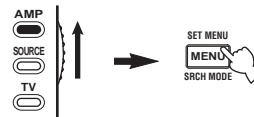

**2** Press  $\Delta$  /  $\nabla$  repeatedly and then  $\triangleright$  to select “Auto Setup”.

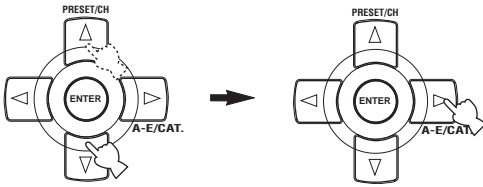

**3** Press  $\Delta$  to select “Information”.



**4** Press  $\triangleright$  and then  $\nabla$  repeatedly to select the desired check items.

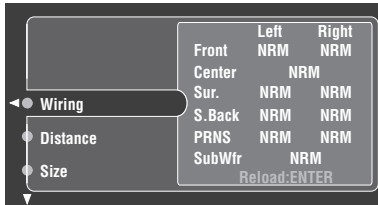
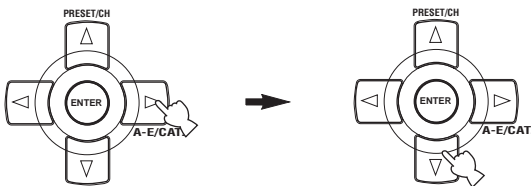

**Wiring (Speaker wiring)**

Displays the polarity of each connected speaker.

- “NRM” appears when the polarity of the connected speaker is normal.
- “REV” appears when the polarity of the connected speaker is reversed.

**Note**

“---” appears when no speaker is connected to the corresponding speaker channel.

**Distance (Speaker distance)**

Displays the speaker distance from the listening position. Press  $\triangleleft$  /  $\triangleright$  to switch the unit to display the value of the each speaker distance.

**Note**

“---” appears when no speaker is connected to the corresponding speaker channel.

**Size (Speaker size)**

Displays the size of the connected speakers. The bass cross over frequency (“Cross”) appears at the bottom of the menu area.

- “LRG” appears when the connected speaker has the ability to reproduce the low-frequency signals effectively.
- “SML” appears when the connected speaker does not have the ability to reproduce the low-frequency signals effectively.

**Note**

“---” appears when no speaker is connected to the corresponding speaker channel.

**Equalizing (Speaker equalizing)**

Displays the result of the adjustment of the frequency responses of each connected speaker.

**Note**

Gray line appears when no speaker is connected to the corresponding speaker channel.

**Level (speaker level)**

Displays the speaker output level of the connected speakers.

**Note**

Gray appears when no speaker is connected to the corresponding speaker channel.

# PLAYBACK

## CAUTION

Extreme caution should be exercised when you play back CDs encoded in DTS. If you play back a CD encoded in DTS on a DTS-incompatible CD player, you will only hear some unwanted noise that may damage your speakers. Check whether your CD player supports CDs encoded in DTS. Also, check the sound output level of your CD player before you play back a CD encoded in DTS.



To play DTS-encoded CDs when using a digital audio connection, set “Decoder Mode” in “Input Select” to “DTS” before the playback (see page 96).

## Basic procedure

(U.S.A. model)

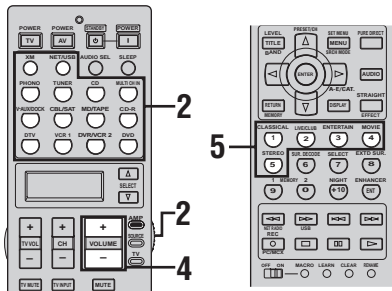
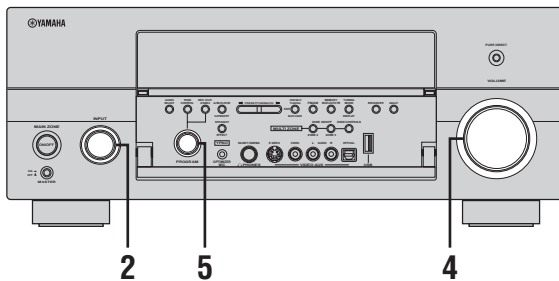

(U.S.A. model)

- 2 Rotate the INPUT selector on the front panel (or set the operation mode selector to AMP and then press one of the input selector buttons on the remote control) to select the desired input source.

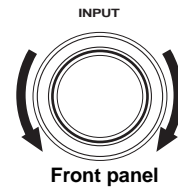

or

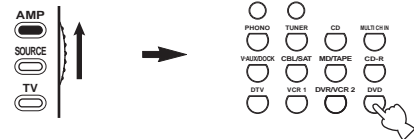

Remote control

The name of the currently selected input source appears in the front panel display and in the short message display for a few seconds.

Available input sources

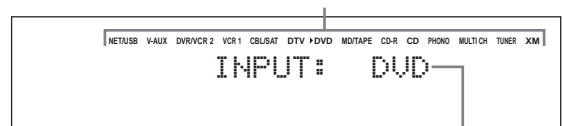

Currently selected input source

- 1 Turn on the video monitor connected to this unit.



- You can control this unit by using the graphical user interface (GUI) screen. See page 44 for details.
- You can turn on or off the short message displays on the video monitor. See page 103 for details.

## Note

For details about controlling XM Satellite Radio when “XM” is selected as the input source, see page 67.

### 3 Start playback on the selected source component or select a broadcast station.

- Refer to the operating instructions for the source component.
- See page 56 for details about tuning instructions.
- See page 67 for details about XM Satellite Radio tuning instructions.

### 4 Rotate **VOLUME** on the front panel (or press **VOLUME +/-** on the remote control) to adjust the volume to the desired output level.

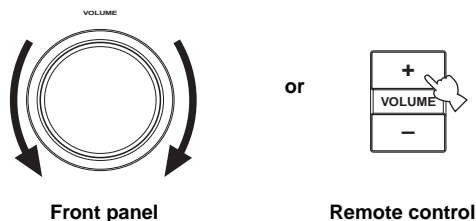

See page 53 to adjust the level of each speaker.

### 5 Rotate the **PROGRAM** selector on the front panel (or press one of the sound field program selector buttons on the remote control repeatedly) to select the desired sound field program.

The name of the selected sound field program appears in the front panel display and in the short message display. See page 47 for details about sound field programs.

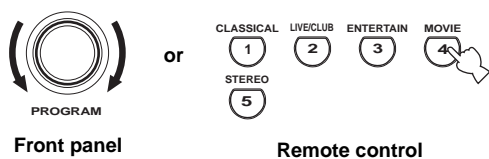

Currently selected sound field program category

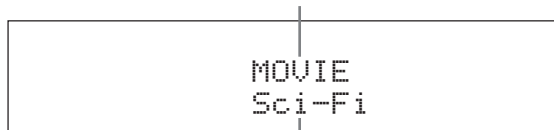

Currently selected sound field program

#### Note

Sound field programs and the Compressed Music Enhancer mode cannot be selected when the component connected to the MULTI CH INPUT jacks is selected as the input source (see page 43) and Audio input jack select is set to "ANALOG" (see page 42).



- Choose a sound field program based on your listening preference, not merely on the name of the program.
- When you select an input source, this unit automatically selects the last sound field program used with the corresponding input source.

#### ■ Guide to contents

When you want to...	See page
Enjoy pure hi-fi stereo sound	52
Adjust the tonal quality of the front speakers	52
Enjoy the compressed music sources in enhanced sound	54
Edit parameters of sound field programs	88
Enjoy the sources which have wide dynamic range at night	55
Use headphones	43
Enjoy multi-channel sources in 2-channel stereo	53
Select a decoder to play back sources with	84
Set this unit to the standby mode automatically	45

## Selecting audio input jacks (AUDIO SELECT)

This unit comes with a variety of input jacks. Use this feature (Audio input jack select) to switch the input jack assigned to an input source when more than one jacks are assigned to an input source.



- We recommend setting Audio input jack select to “AUTO” in most cases.
- You can adjust the default Audio input jack select of this unit by using “Audio Select” in “Option” (see page 114).
- You can also set Audio input jack select setting in “Audio Select” in “Input Select” (see page 96).

**1 Rotate the INPUT selector on the front panel (or press one of the input selector buttons on the remote control) to select the desired input source.**

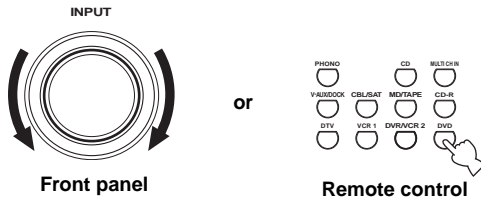

**2 Press AUDIO SELECT on the front panel (or AUDIO SEL on the remote control) repeatedly to select the desired Audio input jack select setting.**

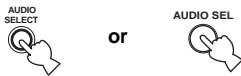

Available input sources

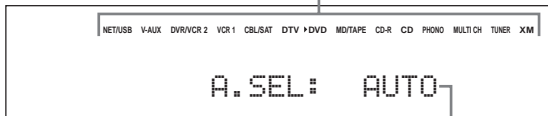

Currently selected Audio input jack select setting

AUTO	Automatically selects input signals in the following order: (1)HDMI (2)Digital signals (3)Analog signals
HDMI	Selects only HDMI signals. When HDMI signals are not input, no sound is output.
COAX/OPT	Automatically selects input signals in the following order: (1)Digital signals input at the COAXIAL jack. (2)Digital signals input at the OPTICAL jack. When no signals are input, no sound is output.
ANALOG	Selects only analog signals. If no analog signals are input, no sound is output.

**Note**

This feature is not available when no digital input jack (OPTICAL, COAXIAL and HDMI) are assigned. Use “I/O Assignment” in “Input Select” to reassign the respective input jack (see page 96).

## Selecting the MULTI CH INPUT component

Use this feature to select the component connected to the MULTI CH INPUT jacks (see page 28) as the input source.

Rotate the input selector on the front panel to select MULTI CH INPUT (or MULTI CH IN on the remote control).

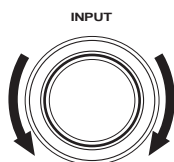

Front panel

or



Remote control



Use "MULTI CH" menu in "Input Select" to set the parameters for MULTI CH INPUT (see page 97).

### Note

Sound field programs and the Compressed Music Enhancer mode cannot be selected when the component connected to the MULTI CH INPUT jacks is selected as the input source (see page 46) and Audio input jack select is set to "ANALOG" (see page 42).

## Using your headphones

Connect a pair of headphones with a stereo analog audio cable plug to the PHONES jack on the front panel.

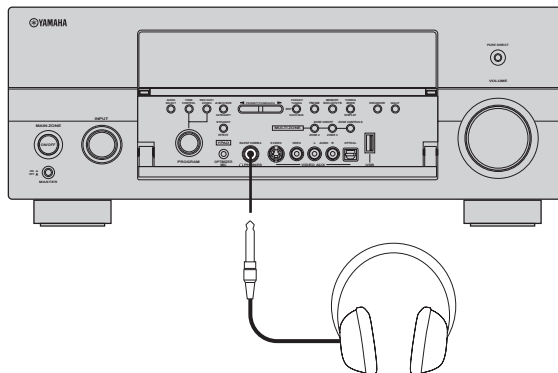

When you select a sound field program, SILENT CINEMA mode activates automatically (see page 51).

### Notes

- When you connect headphones, no signals are output at the speaker terminals.
- When headphones are used, only front L/R channel signals are output.
- All Dolby Digital and DTS audio signals are mixed down to the left and right headphone channels.

## Muting the audio output

Press MUTE on the remote control to mute the audio output. Press MUTE again to resume the audio output.



- You can also rotate VOLUME on the front panel or press VOLUME +/- on the remote control to resume the audio output.
- You can adjust the muting level by using the "Muting Type" parameter in "Sound" (see page 100).
- The MUTE indicator flashes in the front panel display when the audio output is muted and disappears from the front panel display when the audio output is resumed.

## Operating the amplifier functions of this unit by using the graphical user interface (GUI) screen

This unit features a sophisticated graphical user interface (GUI) screen that helps you to control the amplifier function of this unit. With the GUI screen, you can view the information of the signals being input and the status of this unit. You can also set up this unit using the GUI screen (see page 87).

### ■ Items in GUI screen

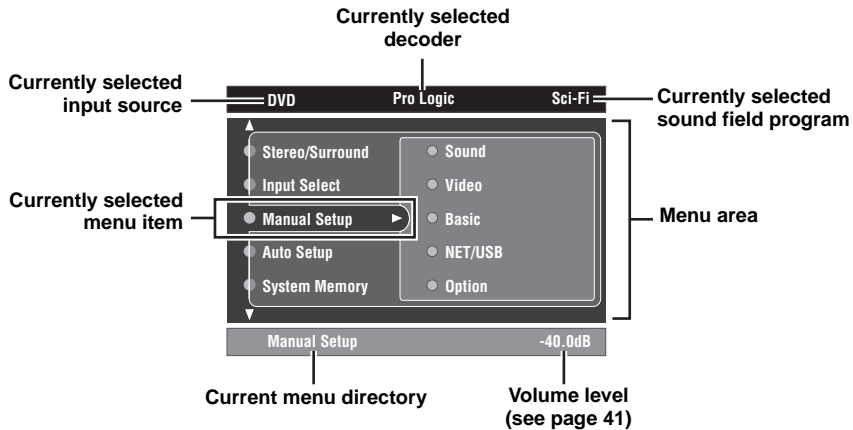

- Set the operation mode selector to AMP when you operate this unit by using GUI screen.
- See page 87 for details about the contents in the menu area.
- This unit reserves the previously selected GUI screen.

### ■ Basic controls in the GUI screen

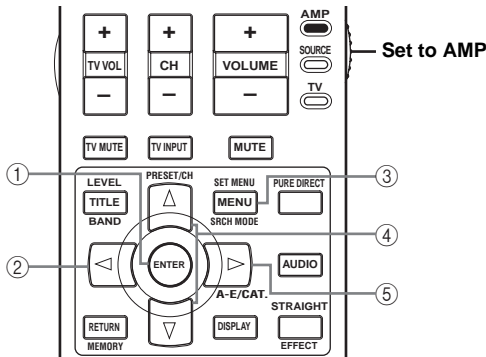

#### ① ENTER

Press to select the currently selected menu item and move to the next menu level.

#### ② Cursor <

Press to return to the previous menu level.

#### ③ SET MENU

Press to display or turn off the GUI screen.

#### ④ Cursor Δ / ▽

Press to select the item in the current menu level.

#### ⑤ Cursor >

Press to select the currently selected menu item and move to the next menu level.



## Playing video sources in the background of an audio source

You can combine a video image from a video source with sound from an audio source. For example, you can enjoy listening to classical music while viewing beautiful scenery from the video source on the video monitor.

**Press the input selector buttons on the remote control to select a video source and then an audio source.**

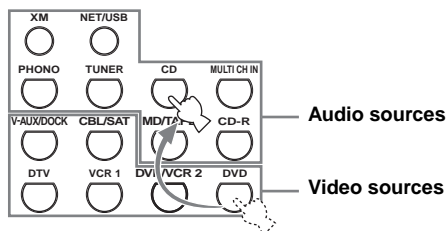

Set the "BGV" parameter in the "MULTI CH" menu to the desired setting to select the default background video input source of the MULTI CH INPUT sources (see page 97).

## Using the sleep timer

Use this feature to automatically set the main zone to the standby mode after a certain amount of time. The sleep timer is useful when you are going to sleep while this unit is playing or recording a source. The sleep timer also automatically turns off any external components connected to the AC OUTLET(S) (see page 32).

**1 Press one of the input selector buttons on the remote control to select the desired input source.**

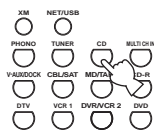

**2 Start playback on the selected source component or select a broadcast station.**

Refer to the operating instructions for the source component.

See page 56 for details about tuning instructions.

**3 Press SLEEP on the remote control repeatedly to set the amount of time.**

Each time you press SLEEP, the front panel display changes as shown below.

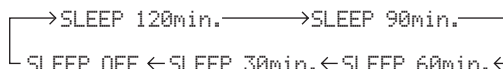

The SLEEP indicator flashes while you are switching the amount of time for the sleep timer. Once the sleep timer is set, the SLEEP indicator lights up in the front panel display, and the display returns to the selected sound field program.

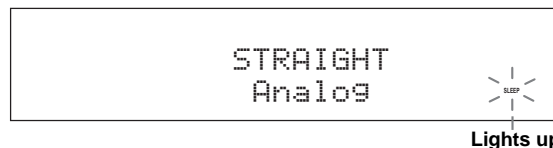
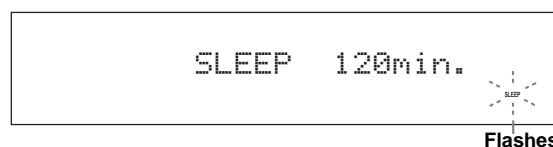

## Canceling the sleep timer

**Press SLEEP on the remote control repeatedly until "SLEEP OFF" appears in the front panel display.**

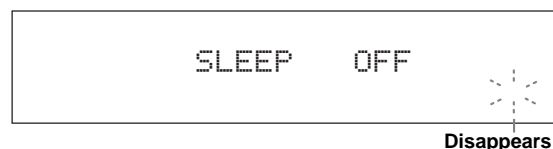

The SLEEP indicator turns off, and "SLEEP OFF" disappears from the front panel display after a few seconds.



The sleep timer setting can also be canceled by pressing STANDBY on the remote control (or MAIN ZONE ON/OFF on the front panel) to set the main zone to the standby mode.

# SOUND FIELD PROGRAMS

This unit is equipped with a variety of precise digital decoders that allow you to enjoy multi-channel playback from almost any stereo or multi-channel sound source. This unit is also equipped with a YAMAHA digital sound field processing (DSP) chip containing several sound field programs which you can use to enhance your playback experience.



- When you set the “Decoder Mode” parameter in “Input Select” to “Auto”, this unit selects the appropriate digital decoder according to the input signal.
- The YAMAHA CINEMA DSP modes are compatible with all Dolby Digital, DTS, and Dolby Surround sources.
- The YAMAHA HiFi DSP sound field programs recreate real-world acoustic environments made from precise measurements taken in actual concert halls, music venues, movie theaters, etc. Thus, you may notice variations in the strength of the reflections coming from the front, back, left and right.
- You can select sound field programs and adjust the parameters by using the GUI screen. See page 88 for details.

## Selecting sound field programs

### Notes

- When you select an input source, this unit automatically selects the last sound field program used with the corresponding input source.
- Sound field programs cannot be selected when the component connected to the MULTI CH INPUT jacks is selected as the input source (see page 43) and Audio input jack select is set to “ANALOG” (see page 42).
- When you play back DSD sources with any sound field program, this unit converts the DSD signals to PCM signals and then applies the selected program.
- When you play back DTS 96/24 sources with any sound field program, this unit applies the selected program without activating the DTS 96/24 decoder.
- Sampling frequencies higher than 48 kHz are sampled down to 48 kHz or lower and then sound field programs are applied.



You can select the desired sound field programs and setting the parameters by using GUI screen. see page 88 for details.

### ■ Front panel operations

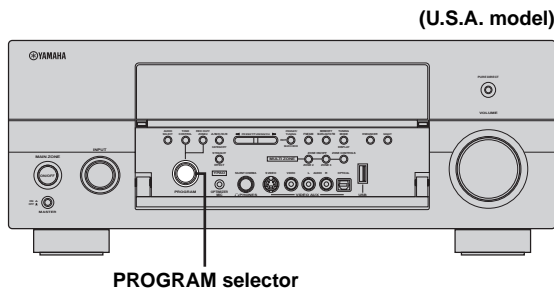

#### Rotate the PROGRAM selector on the front panel.

The name of the selected sound field program appears in the front panel display and in the short message display.

### ■ Remote control operations

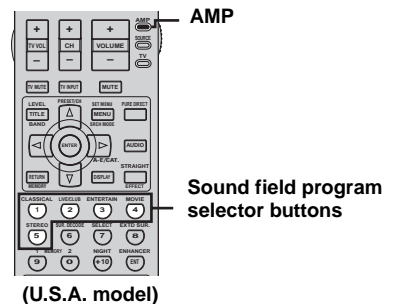

#### Set the operation mode selector to AMP and then press one of the sound field program selector buttons on the remote control repeatedly.

The name of the selected sound field program appears in the front panel display and in the short message display.

## Sound field program descriptions



Select a sound field program based on your listening preference, not merely on the name of the program, etc.

Remote control button	Category of the program	Name of the program	Created sound fields (see page 13)	CINEMA DSP or HiFi DSP
	MOVIE	Sci-Fi		CINEMA DSP
This program clearly reproduces dialog and sound effects in the latest sound form for science fiction films, thus creating a broad and expansive cinematic space amid silence. You can enjoy science fiction films in a virtual-space sound field that includes Dolby Surround, Dolby Digital and DTS-encoded software employing the most advanced techniques.				
DSP Level Init. Delay	Room Size Sur. Init. Delay	Sur. Room Size SB Init. Delay	SB Room Size Dialogue Lift	

Available sound field parameters (see page 89) Program description

### ■ For music audio sources





For audio music sources, we also recommend using the Pure Direct mode (see page 52), the “STRAIGHT” mode (see page 51) or surround decode mode (see page 84).

	CLASSICAL	Hall in Munich		HiFi DSP
This is a large fan-shaped concert hall which has approximately 2500 seats. Almost the whole interior is made of wood. There is relatively little reflection from the walls, and sound spreads finely and beautifully.				
DSP Level Init. Delay	Room Size Liveness	Dialogue Lift		
	CLASSICAL	Hall in Vienna		HiFi DSP
A classic shoe-box type concert hall with approximately 1700 seats. Pillars and ornate carvings create extremely complex reflections which produce a very full, rich sound.				
DSP Level Init. Delay	Room Size Liveness	Dialogue Lift		
	CLASSICAL	Hall in Amsterdam		HiFi DSP
This is a large 2200 seat shoe-box type concert hall in Amsterdam. It has a circular stage with seats located behind the stage.				
DSP Level Init. Delay	Room Size Liveness	Dialogue Lift		
	CLASSICAL	Church in Freiburg		HiFi DSP
This program creates the acoustic environment of a big church located in south Germany. The reverberation delay is very long while the early reflections are smaller than with other sound field programs.				
DSP Level Init. Delay	Liveness Rev. Time	Rev. Delay Rev. Level	Dialogue Lift	

CLASSICAL 1	CLASSICAL	Chamber		<b>HiFi DSP</b>
This program creates a relatively wide space with a high ceiling like an audience hall in a palace. It offers pleasant reverberations that are suitable for courtly music and chamber music.				
<b>DSP Level Init. Delay</b>	<b>Liveness Rev. Time</b>	<b>Rev. Delay Rev. Level</b>	<b>Dialogue Lift</b>	

LIVE/CLUB 2	LIVE/CLUB	Village Vanguard		<b>HiFi DSP</b>
A traditional jazz club in New York, located on 7th Avenue. This room has a low ceiling, and the “stage” is located at the corner of the room. This program creates an intimate “close-to-the music” feel.				
<b>DSP Level Init. Delay</b>	<b>Room Size Liveness</b>	<b>Dialogue Lift</b>		

LIVE/CLUB 2	LIVE/CLUB	Warehouse Loft		<b>HiFi DSP</b>
This program simulates a space enclosed by concrete. An energetic sound field is created with relatively clear reflections from the walls.				
<b>DSP Level Init. Delay</b>	<b>Room Size Liveness</b>	<b>Rev. Time Rev. Delay</b>	<b>Rev. Level Dialogue Lift</b>	

LIVE/CLUB 2	LIVE/CLUB	Cellar Club		<b>HiFi DSP</b>
This program simulates a live house with a low ceiling and homey atmosphere. A realistic, live sound field features powerful sound as if the listener is in a row in front of a small stage.				
<b>DSP Level Init. Delay</b>	<b>Room Size Liveness</b>	<b>Dialogue Lift</b>		

LIVE/CLUB 2	LIVE/CLUB	The Roxy Theatre		<b>HiFi DSP</b>
The ideal program for lively, dynamic rock music. The data for this program was recorded at LA's hottest rock club. The listener's virtual seat is at the center-left of the hall.				
<b>DSP Level Init. Delay</b>	<b>Room Size Liveness</b>	<b>Rev. Time Rev. Delay</b>	<b>Rev. Level Dialogue Lift</b>	



LIVE/CLUB 2	LIVE/CLUB	The Bottom Line		<b>HiFi DSP</b>
This is the sound field at stage front in The Bottom Line, a famous New York jazz club. The floor can seat 300 people to the left and right in a sound field offering real and vibrant sound.				
<b>DSP Level Init. Delay</b>	<b>Room Size Liveness</b>	<b>Dialogue Lift</b>		

■ **For various sources**



**Note**

The available sound field parameters and the created sound fields differ depending on the input sources and the settings of this unit.

ENTERTAIN 3	ENTERTAINMENT	Sports		<b>CINEMA DSP</b>
This program allows the listeners to enjoy stereo sport broadcasts and studio variety programs with enriched live feeling. In sports broadcasts, the voices of the commentator and sportscaster are positioned clearly on the center while the atmosphere of the stadium expands in an optimum space to offer the listeners with a feeling of presence in the stadium.				
<b>DSP Level Init. Delay</b>	<b>Room Size Sur. Init. Delay</b>	<b>Sur. Room Size SB Init. Delay</b>	<b>SB Room Size Dialogue Lift</b>	

	ENTERTAINMENT	Action Game		
This sound field has been optimized for action games such as car racing and FPS games. It uses the reflection data that limits the effects range per channel in order to offer a powerful playing environment with a being-there feeling by enhancing various effects tones while maintaining a clear sense of directions.				
<b>DSP Level</b>	<b>Room Size</b>	<b>Sur. Room Size</b>	<b>SB Room Size</b>	
<b>Init. Delay</b>	<b>Sur. Init. Delay</b>	<b>SB Init. Delay</b>	<b>Dialogue Lift</b>	



  

	ENTERTAINMENT	Roleplaying Game		
This sound field has been optimized for role-playing and adventure games. It combines the sound field effects for movies and the sound field design used with "Action Game" to represent the depth and 3D feeling of the field during play, while offering movie-like surround effects in the movie scenes in the game.				
<b>DSP Level</b>	<b>Room Size</b>	<b>Sur. Room Size</b>	<b>SB Room Size</b>	
<b>Init. Delay</b>	<b>Sur. Init. Delay</b>	<b>SB Init. Delay</b>	<b>Dialogue Lift</b>	



## ■ For visual sources of music

### Note

The available sound field parameters and the created sound fields differ depending on the input sources and the settings of this unit.

	ENTERTAINMENT	Music Video		
This sound field offers an image of a concert hall for live performance of pop, rock and jazz music. The listener can indulge oneself in a hot live space thanks to the presence sound field that emphasizes the vividness of vocals and solo play and the beat of rhythm instruments, and to the surround sound field that reproduces the space of a big live hall.				
<b>DSP Level</b>	<b>Room Size</b>	<b>Sur. Room Size</b>	<b>SB Room Size</b>	
<b>Init. Delay</b>	<b>Sur. Init. Delay</b>	<b>SB Init. Delay</b>	<b>Dialogue Lift</b>	

	ENTERTAINMENT	Recital/Opera		
This program controls the amount of reverberations at an optimum level and emphasizes the depth and clarity of human voices. "Opera" offers the reverberations of an orchestra box in front of the listener at the same time as providing the acoustic positioning and feeling of presence on the stage. The surround sound field is relatively moderate, but the data for concert hall effects are used to represent the inherent beauty of music. The listener will not be fatigued even after long hours of opera entertainment.				
<b>DSP Level</b>	<b>Room Size</b>	<b>Sur. Room Size</b>	<b>SB Room Size</b>	
<b>Init. Delay</b>	<b>Sur. Init. Delay</b>	<b>SB Init. Delay</b>	<b>Dialogue Lift</b>	



## ■ For movie sources

















You can select the desired decoder used with following sound field program (except "Mono Movie"). See page 85 for details.

### Note





The available sound field parameters and the created sound fields differ depending on the input sources and the settings of this unit.

	MOVIE	Standard		
This program create a sound field emphasizing the surrounding feeling without disturbing the original acoustic positioning of multi-channel audio such as Dolby Digital and DTS. It has been designed with the concept of "an ideal movie theater", in which the audience is surrounded by beautiful reverberations from the left, right and rear.				
<b>DSP Level</b>	<b>Sur. Room Size</b>	<b>SB Init. Delay</b>	<b>SB Liveness</b>	
<b>Sur. Init. Delay</b>	<b>Sur. Liveness</b>	<b>SB Room Size</b>	<b>Dialogue Lift</b>	

**SOUND FIELD PROGRAMS**

	MOVIE	Spectacle		
<p>This program creates the extremely wide sound field of a 70-mm movie theater. It precisely reproduces the source sound in detail, making both the video and the sound field incredibly real. This is ideal for any kind of video source encoded with Dolby Surround, Dolby Digital or DTS (especially large-scale movie productions).</p>				
<b>DSP Level</b>	<b>Room Size</b>	<b>Sur. Room Size</b>	<b>SB Room Size</b>	
<b>Init. Delay</b>	<b>Sur. Init. Delay</b>	<b>SB Init. Delay</b>	<b>Dialogue Lift</b>	
	MOVIE	Sci-Fi		
<p>This program clearly reproduces dialog and sound effects in the latest sound form for science fiction films, thus creating a broad and expansive cinematic space amid silence. You can enjoy science fiction films in a virtual-space sound field that includes Dolby Surround, Dolby Digital and DTS-encoded software employing the most advanced techniques.</p>				
<b>DSP Level</b>	<b>Room Size</b>	<b>Sur. Room Size</b>	<b>SB Room Size</b>	
<b>Init. Delay</b>	<b>Sur. Init. Delay</b>	<b>SB Init. Delay</b>	<b>Dialogue Lift</b>	
	MOVIE	Adventure		
<p>This program is ideal for precisely reproducing the sound design of the newest 70-mm and multichannel soundtrack films. The sound field is made to be similar to that of the newest movie theaters, so the reverberations of the sound field itself are restrained as much as possible.</p>				
<b>DSP Level</b>	<b>Room Size</b>	<b>Sur. Room Size</b>	<b>SB Room Size</b>	
<b>Init. Delay</b>	<b>Sur. Init. Delay</b>	<b>SB Init. Delay</b>	<b>Dialogue Lift</b>	
	MOVIE	Drama		
<p>This sound field features stable reverberations that match a wide range of movie genres from serious dramas to musicals and comedies. The reverberations are modest but offer an optimum 3D feeling, reproducing effects tones and background music softly but cubically around clear words and center positioning in a way that does not fatigue the listener even after long hours of viewing.</p>				
<b>DSP Level</b>	<b>Room Size</b>	<b>Sur. Room Size</b>	<b>SB Room Size</b>	
<b>Init. Delay</b>	<b>Sur. Init. Delay</b>	<b>SB Init. Delay</b>	<b>Dialogue Lift</b>	
	MOVIE	Mono Movie		
<p>This program is provided for reproducing monaural video sources (such as old movies). The program produces the optimum reverberation to create sound depth using only the presence sound field.</p>				
<b>DSP Level</b>	<b>Room Size</b>	<b>Rev. Time</b>	<b>Rev. Delay</b>	
<b>Init. Delay</b>	<b>Liveness</b>	<b>Rev. Level</b>	<b>Dialogue Lift</b>	

■ **Stereo playback**

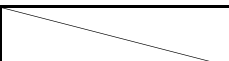
	STEREO	2ch STEREO		
<p>Use this program to mix down multi-channel sources to 2 channels. See page 53 for details.</p>				
<b>Direct</b>				
	STEREO	7ch STEREO		<b>HiFi DSP</b>
<p>Use this program to output sound from all speakers. When you play back multi-channel sources, this unit downmixes the source to 2 channels, and then output the sound from all speakers. This program creates a larger sound field and is ideal for background music at parties, etc.</p>				
<b>Center Level</b>	<b>Surround R Level</b>	<b>Presence L Level</b>		
<b>Surround L Level</b>	<b>Sur. Back Level</b>	<b>Presence R Level</b>		

## ■ Using sound field programs without surround speakers (Virtual CINEMA DSP)

Virtual CINEMA DSP allows you to enjoy the CINEMA DSP programs without surround speakers. It creates virtual speakers to reproduce the natural sound field. When you set “Surround” to “None” (see page 106), Virtual CINEMA DSP activates automatically whenever you select a CINEMA DSP sound field program (see page 47).

### Note

Virtual CINEMA DSP will not activate even when “Surround” is set to “None” (see page 106) in the following cases:

- when the component connected to the MULTI CH INPUT jacks is selected as the input source (see page 43).
- when headphones are connected to the PHONES jack.
- when the Pure Direct (see page 52) or “2ch Stereo” mode (see page 53) is selected, or when this unit is in the “STRAIGHT” mode (see page 51).

## ■ Enjoying multi-channel sources and sound field programs with headphones (SILENT CINEMA)

SILENT CINEMA allows you to enjoy multi-channel music or movie sound, including Dolby Digital and DTS sources, through ordinary headphones. SILENT CINEMA activates automatically whenever you connect headphones to the PHONES jack while listening to CINEMA DSP or HiFi DSP sound field programs (see page 47). When activated, the SILENT CINEMA indicator lights up in the front panel display.

### Notes

- SILENT CINEMA does not activate when the component connected to the MULTI CH INPUT jacks is selected as the input source (see page 43).
- SILENT CINEMA is not effective when the Pure Direct (see page 52) or “2ch Stereo” mode (see page 53) is selected, or when this unit is in the “STRAIGHT” mode (see page 51).

## Enjoying unprocessed input sources

When this unit is in the “STRAIGHT” mode, 2-channel stereo sources are output from only the front left and right speakers. Multi-channel sources are decoded straight into the appropriate channels without any additional effect processing.



You can also select the “STRAIGHT” mode by using GUI screen. See page 88 for details.

**Press STRAIGHT on the front panel (or on the remote control) to select “STRAIGHT”.**

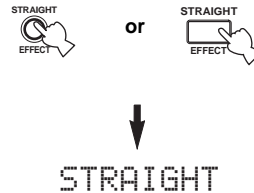

Format	Description
Dolby Digital	Standard processing for Dolby Digital sources.
DTS	Standard processing for DTS sources. When the input source is DTS-ES Discrete or DTS-ES Matrix format, the respective indicator appears in the front panel display.
DSD	Plays back DSD (Direct Stream Digital) sources.
PCM	Plays back PCM (Pulse Code Modulation) sources.
MPCM	Plays back multi-channel PCM (Pulse Code Modulation) sources.
Analog	Plays back analog sources.

## ■ Deactivating the “STRAIGHT” mode

**Press STRAIGHT on the remote control so that “STRAIGHT” disappears from the front panel display.**

The sound effect is turned back on.

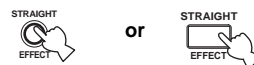

# USING AUDIO FEATURES

## Enjoying pure hi-fi sound

Use the Pure Direct mode to enjoy the pure fidelity sound of the selected source. When the Pure Direct mode is activated, this unit plays back the selected source with the least circuitry.

**Press PURE DIRECT on the front panel (or on the remote control) to turn on or off the Pure Direct mode.**

The PURE DIRECT button on the front panel lights up while this unit is in the Pure Direct mode. The front panel display automatically dims.

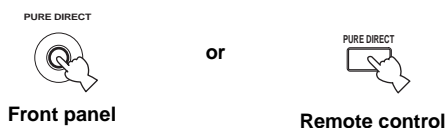

### Notes

- When you play back the multi-channel PCM sources (less than 192 kHz), this unit downmixes the multi-channel signals according to the “Speaker Set” in “Basic” (see page 105).
- When the component connected to the HDMI IN jacks is selected as the input source and Audio input jack select is set to “AUTO” or “HDMI”, this unit does not turn off the video circuitry in the Pure Direct mode.
- When you set Audio input jack select to “AUTO”, “HDMI” or “COAX/OPT” (see page 42) and play back the Dolby Digital, DTS or multi channel PCM sources, this unit activates the corresponding decoder.
- The following operations are not possible when this unit is in the Pure Direct mode:
  - switching the sound field program
  - displaying the GUI screen
  - operating video functions (video conversion, etc.)
- The Pure Direct mode is automatically canceled whenever this unit is turned off.



The front panel display turns on momentarily when an operation is performed.

## Adjusting the tonal quality

Use this feature to adjust the balance of bass and treble for the front L/R, center, presence L/R speaker channels and the subwoofer channel.

- 1 Press **TONE CONTROL** on the front panel repeatedly to select the high-frequency response (**TREBLE**) or the low-frequency response (**BASS**).



- 2 Rotate the **PROGRAM** selector to adjust the high-frequency response (**TREBLE**) or the low-frequency response (**BASS**).



### ■ Bypassing the tone control circuitry

**Press TONE CONTROL repeatedly to select BYPASS and cancel the tone control.**



### Notes

- If you increase or decrease the high-frequency or the low-frequency sound to an extreme level, the tonal quality of the surround speakers may not match that of the front L/R, center, presence L/R speakers and the subwoofer.
- TONE CONTROL is not effective when PURE DIRECT is selected, or when MULTI CH INPUT is selected as the input source.



Use “Tone Control” parameter in “Sound” menu to adjust the balance of bass and treble output to your speakers or headphones by using GUI screen. See page 99 for details.



## Adjusting the speaker level

You can adjust the output level of each speaker while listening to a music source. This is also possible when playing sources input at the MULTI CH INPUT jacks.

### Note

This operation will override the level adjustments made in “Auto Setup” (see page 35) and “Speaker Level” (see page 109).

- 1 Set the operation mode selector to AMP and then press LEVEL on the remote control repeatedly to select the speaker you want to adjust.



Display	Adjusted speaker
FRONT L	Front left speaker
CENTER	Center speaker
FRONT R	Front right speaker
SUR. R	Surround right speaker
SB L	Surround back right speaker
SB R	Surround back left speaker
SUR. L	Surround left speaker
SWFR	Subwoofer
PRNS L	Presence left speaker
PRNS R	Presence right speaker



- Once you press LEVEL on the remote control, you can also select the speaker by pressing  $\Delta$  /  $\nabla$ .
- Instead of “SB R” and “SB L”, “SB” is displayed if “Surround Back” is set to either “Small x1” or “Large x1” (see page 106).

- 2 Press  $\triangleleft$  /  $\triangleright$  on the remote control to adjust the speaker output level.

- Press  $\triangleright$  to increase the value.
- Press  $\triangleleft$  to decrease the value.

Control range: -10 dB to +10 dB

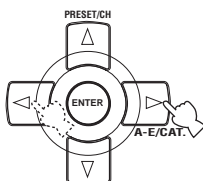

## Enjoying multi-channel sources in 2-channel stereo

You can mix down multi-channel sources to 2 channels and enjoy playback in 2-channel stereo.

- Set the operation mode to AMP and then press STEREO on the remote control repeatedly to select “2ch Stereo”.

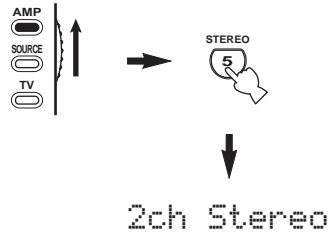

- You can use a subwoofer with this program when “Bass Out” is set to “SWFR” or “Both” (see page 107).
- You can also select the “2ch Stereo” mode by rotating the PROGRAM selector on the front panel.
- You can also select the “2ch Stereo” mode and adjust the parameter by using GUI screen. See page 88 for details.

## Selecting the Compressed Music Enhancer mode

Compression artifacts (such as the MP3 format) are created by a lossy compression scheme where the audio is resampled to lower the bit rate and to remove sounds that are indistinguishable to typical human hearing. The Compressed Music Enhancer feature of this unit enhances your listening experience by regenerating the missing harmonics in a compression artifact. As a result, flattened complexity due to the loss of high-frequency fidelity as well as lack of bass due to the loss of low-frequency bass is compensated, providing improved performance of the overall sound system.

### Notes

- When you play back DSD sources or PCM sources whose sampling frequencies are higher than 48 kHz, this unit samples them down to 48 kHz or lower and applies the Compressed Music Enhancer mode.
- The Compressed Music Enhancer mode is not effective with any of the sound field programs.



You can also select the Compressed Music Enhancer mode and adjust the parameter by using GUI menu. See page 88 for details.

**Press ENHANCER on the front panel (or set the operation mode selector to AMP and then press ENHANCER on the remote control) repeatedly to select the desired Compressed Music Enhancer mode.**

The following short message appears on the video monitor and the ENHANCER indicator lights up in the front panel display.

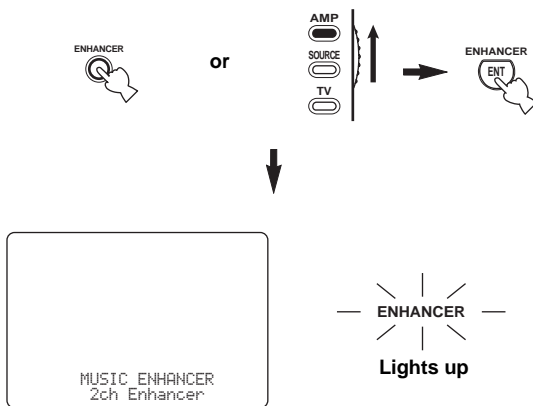

Choices: **2ch Enhancer**, 7ch Enhancer, Off

- Select “2ch Enhancer” to play back compression artifacts in 2-channel stereo.
- Select “7ch Enhancer” to play back compression artifacts in 7-channel stereo.
- Select “Off” to turn off the Compressed Music Enhancer mode.

### Note

When you select “Off”, this unit returns to the previously selected sound field program.

## Selecting the night listening mode

The night listening modes are designed to improve listenability at lower volumes or at night. Choose either “NIGHT:CINEMA” or “NIGHT:MUSIC” depending on the type of material you are playing.

- 1 Press **NIGHT** on the front panel (or set the operation mode selector to **AMP** and then press **NIGHT** on the remote control) repeatedly to select “NIGHT:CINEMA” or “NIGHT:MUSIC”.

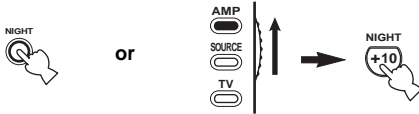

Choices: NIGHT:CINEMA, NIGHT:MUSIC, OFF

- Select “NIGHT:CINEMA” when watching films to reduce the dynamic range of film soundtracks and make dialog easier to hear at lower volumes.
- Select “NIGHT:MUSIC” when listening to music sources to preserve ease-of-listening for all sounds.
- Select “OFF” if you do not want to use this feature.



When a night listening mode is selected, the NIGHT indicator lights up in the front panel display.

- 2 Press **◀/▶** on the remote control to adjust the effect level while “NIGHT:CINEMA” or “NIGHT:MUSIC” is displayed in the front panel display.

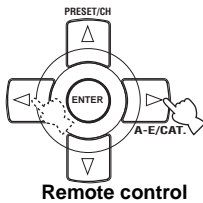

Remote control



Effect.Lvl: MID

Choices: MIN, **MID**, MAX

- Select “MIN” for minimum compression.
- Select “MID” for standard compression.
- Select “MAX” for maximum compression.



“NIGHT:CINEMA” and “NIGHT:MUSIC” adjustments are stored independently.

### Notes

- You cannot use the night listening modes in the following cases:
  - when the Pure Direct mode (see page 52) is selected.
  - when the component connected to the MULTI CH INPUT jacks is selected as the input source (see page 43).
  - when headphones are connected to the PHONES jack.
- The night listening modes may vary in effectiveness depending on the input source and surround sound settings you use.

# FM/AM TUNING

There are 2 tuning methods: automatic and manual. Automatic tuning is effective when station signals are strong and there is no interference. If the signal from the station you want to select is weak, tune into it manually. You can also use the automatic and manual preset tuning features to store up to 40 stations (A1 to E8: 8 preset station numbers in each of the 5 preset station groups). Furthermore, you can recall any preset stations and exchange the assignment of two preset stations with each other.

## Note

Orient the connected FM and AM antennas for the best reception.

## FM/AM controls and functions

### ■ Front panel functions

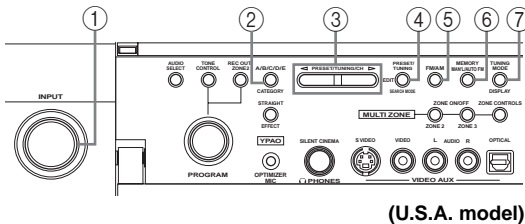

#### ① INPUT selector

Selects "TUNER" as the input source.

#### ② A/B/C/D/E

Selects one of the 5 preset station groups (A to E) (see page 59).

#### ③ PRESET/TUNING/CH ◀ / ▶

- Selects one of the 8 preset station numbers (1 to 8) when the colon (:) is displayed in the front panel display (see page 59).
- Selects the tuning frequency when the colon (:) is not displayed in the front panel display (see page 58).

#### ④ PRESET/TUNING, EDIT

- Switches the function of PRESET/TUNING/CH ◀ / ▶ between selecting preset station numbers and selecting the tuning frequency.
- Edits the assignments of preset stations (see page 60).

#### ⑤ FM/AM

Switches the reception band between FM and AM (see page 57).

#### ⑥ MEMORY

Stores a preset station in the memory. Hold down this button for more than 3 seconds to start automatic preset tuning (see page 59).

#### ⑦ TUNING MODE

Switches between automatic tuning (the AUTO indicator is turned on) and manual tuning (the AUTO indicator is turned off) (see page 57).

### ■ Remote control functions

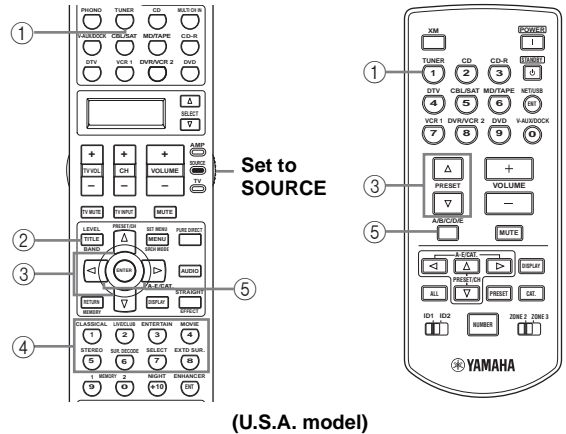

Set to SOURCE

#### ① TUNER

Selects "TUNER" as the input source. This unit is turned into the last selected station.

#### ② BAND

Switches the reception band between FM and AM (see page 57). This unit is turned into the last selected AM or FM station.

#### ③ PRESET/CH Δ / ▽

Selects one of the 8 preset station numbers (1 to 8) when the colon (:) is displayed in the front panel display (see page 60).

#### ④ Numeric buttons

Use numbers 1 through 8 to select preset stations (see page 61).

#### ⑤ A-E/CAT. ◀ / ▶, A/B/C/D/E

Selects one of the preset station groups (A to E) (see page 59).

## Automatic tuning

Automatic tuning is effective when station signals are strong and there is no interference.

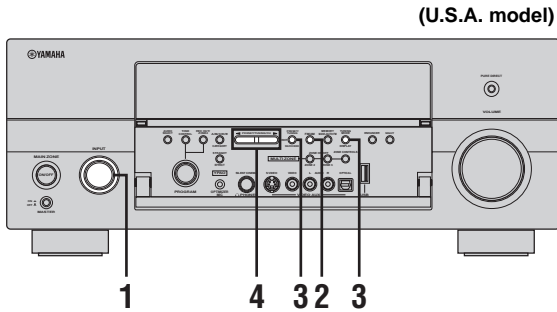

- 1 Rotate the INPUT selector to select "TUNER" as the input source.

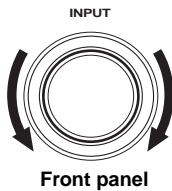

- 2 Press FM/AM to select the reception band. "FM" or "AM" appears in the front panel display.



- 3 Press TUNING MODE so that the AUTO indicator lights up in the front panel display.

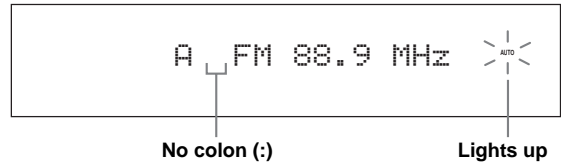

If a colon (:) appears in the front panel display, tuning is not possible. Press PRESET/TUNING to turn the colon (:) off.



- 4 Press PRESET/TUNING/CH < / > once to begin automatic tuning.

When this unit is tuned into a station, the TUNED indicator lights up and the frequency of the received station is shown in the front panel display.

- Press > to tune into a higher frequency.
- Press < to tune into a lower frequency.

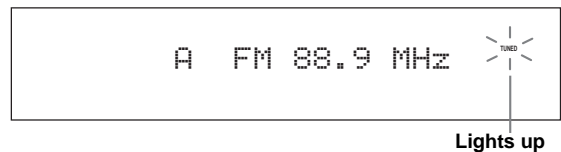

## Manual tuning

If the signal received from the station you want to select is weak, tune into it manually.

### Note

Manually tuning into an FM station automatically switches the tuner to monaural reception to increase the signal quality.

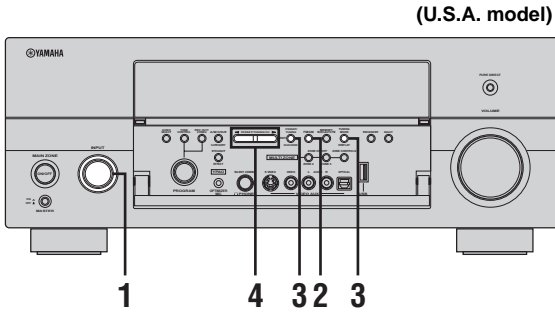

- 1 Rotate the INPUT selector to select “TUNER” as the input source.

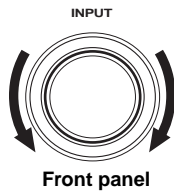

- 2 Press FM/AM to select the reception band. “FM” or “AM” appears in the front panel display.



- 3 Press TUNING MODE so that the AUTO indicator disappears from the front panel display.



No colon (:)

If a colon (:) appears in the front panel display, tuning is not possible. Press PRESET/TUNING (EDIT) to turn the colon (:) off.



- 4 Press PRESET/TUNING/CH <|/> to tune into the desired station manually. Hold down the button to continue searching.

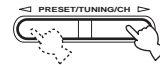

## Automatic preset tuning

You can use the automatic preset tuning feature to store up to 40 FM stations with strong signals (A1 to E8: 8 preset station numbers in each of the 5 preset station groups) in order. You can then recall any preset station easily by selecting the preset station number.

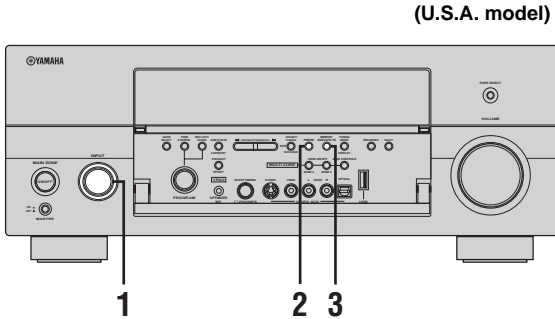

- 1 Rotate the **INPUT** selector to select “**TUNER**” as the input source.

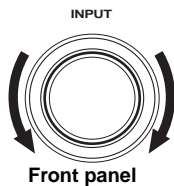

- 2 Press **FM/AM** to select “**FM**” as the reception band.

“FM” appears in the front panel display.



- 3 Press and hold **MEMORY** for more than 3 seconds.

The preset station number as well as the **MEMORY** and **AUTO** indicators flashes. After approximately 5 seconds, automatic presetting starts from the current frequency and proceeds toward higher frequencies.

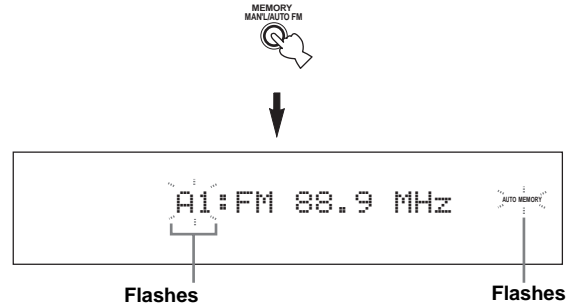

When automatic preset tuning is completed, the front panel display shows the frequency of the last preset station.



- You can specify the preset number from which this unit stores FM stations. Press A/B/C/D/E and then PRESET/TUNING/CH </> repeatedly after you perform step 3 to select the preset station number under which the first station will be stored.
- You can begin tuning toward lower frequencies to store FM stations automatically. Press PRESET/TUNING so that the colon (:) disappears from the front panel display and then press PRESET/TUNING/CH </> after pressing and holding **MEMORY** for more than 3 seconds.

### Notes

- Any stored station data existing under a preset station number is cleared when you store a new station under the same preset station number.
- If the number of received stations does not reach 40 (E8), automatic preset tuning automatically stops after searching for all the available stations.
- Only FM stations with sufficient signal strength are stored automatically by automatic preset tuning. If the station you want to store is weak in signal strength, tune into it manually and store it as described in “Manual preset tuning” on page 60.

## Manual preset tuning

You can also store up to 40 stations (A1 to E8: 8 preset station numbers in each of the 5 preset station groups) manually.

(U.S.A. model)

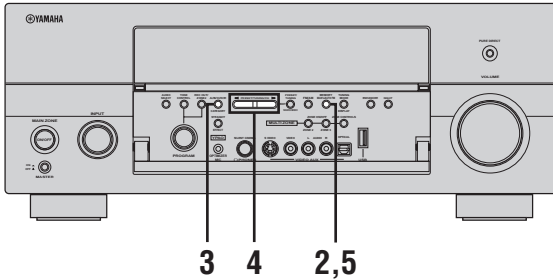

**1 Tune into a station automatically or manually.**  
See pages 57 and 58 for tuning instructions.

**2 Press MEMORY.**  
The MEMORY indicator flashes in the front panel display for approximately 5 seconds.



**3 Press A/B/C/D/E repeatedly to select a preset station group (A to E) while the MEMORY indicator is flashing.**

The selected preset station group letter appears. Check that the colon (:) appears in the front panel display.

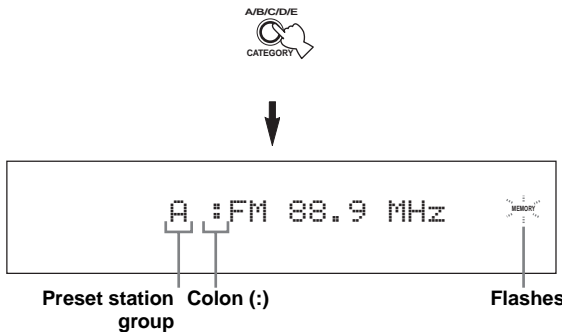

**4 Press PRESET/TUNING/CH < / > to select a preset station number (1 to 8) while the MEMORY indicator is flashing.**

- Press > to select a higher preset station number.
- Press < to select a lower preset station number.

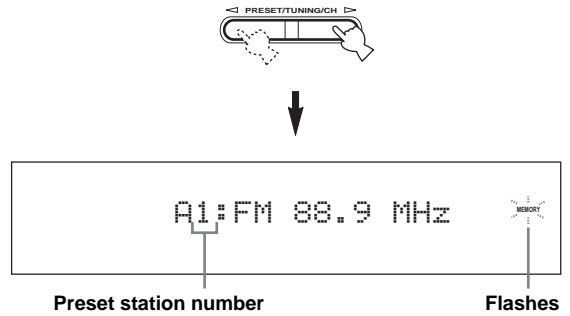

**5 Press MEMORY while the MEMORY indicator is flashing.**

The station band and frequency appear in the front panel display with the preset station group and number you have selected. The MEMORY indicator disappears from the front panel display.

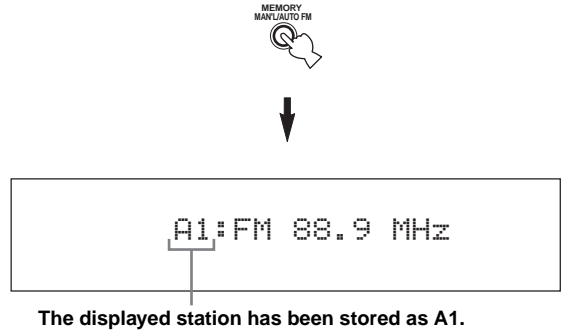

### Notes

- Any stored station data existing under a preset station number is cleared when you store a new station under the same preset station number.
- The reception mode (stereo or monaural) is stored along with the station frequency.



## Selecting preset stations

You can tune into any desired station simply by selecting the preset station group and number under which it was stored.

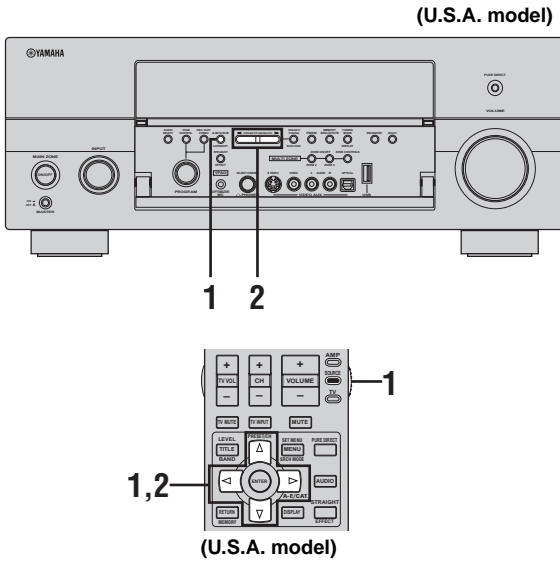

- Press **PRESET/TUNING/CH**  $\triangleleft$  /  $\triangleright$  on the front panel (or **PRESET/CH**  $\triangle$  /  $\nabla$  on the remote control) to select the desired preset station number (1 to 8).

The preset station group and number appear in the front panel display along with the station band and frequency.

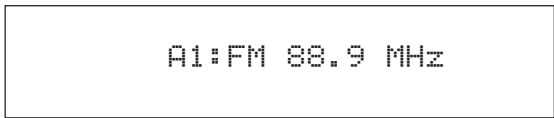
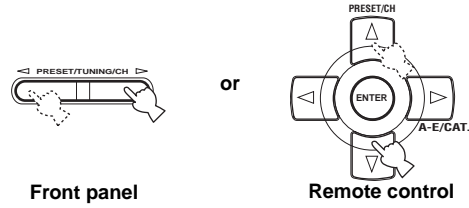

When performing this operation with the remote control, set the operation mode selector to **SOURCE** and then press **TUNER** to select "TUNER" as the input source.

- Press **A/B/C/D/E** on the front panel (or set the operation mode selector to **SOURCE** and then press **A-E/CAT.**  $\triangleleft$  /  $\triangleright$  on the remote control) to select the desired preset station group (A to E).

The preset station group letter appears in the front panel display and changes each time you press the button.



or

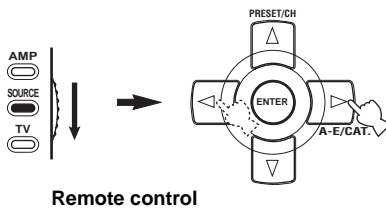

## Exchanging preset stations

You can exchange the assignments of two preset stations with each other. The example below describes the procedure to exchange preset station “E1” with “A5”.

(U.S.A. model)

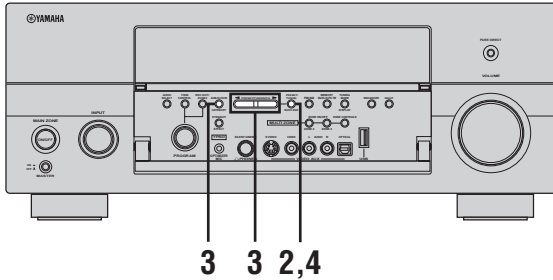

- 1 Select preset station “E1” using A/B/C/D/E and PRESET/TUNING/CH ◀/▶.

See “Selecting preset stations” on page 61.

- 2 Press and hold EDIT for more than 3 seconds.

“E1” and the MEMORY indicator flash in the front panel display.

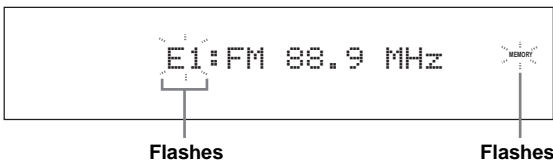

- 3 Select preset station “A5” using A/B/C/D/E and PRESET/TUNING/CH ◀/▶.

“A5” and the MEMORY indicator flash in the front panel display.

See “Selecting preset stations” on page 61.

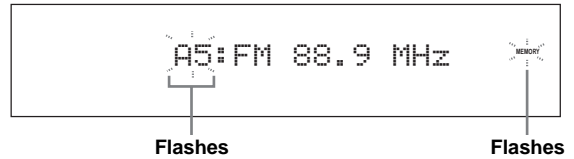
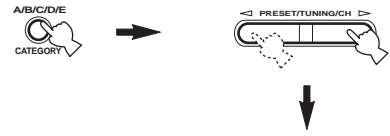

- 4 Press EDIT again.

“EDIT E1-A5” appears in the front panel display and the assignments of the two preset stations are exchanged.

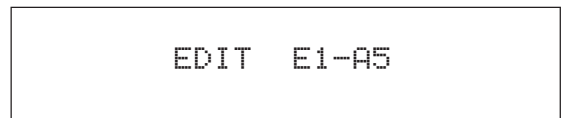

# XM SATELLITE RADIO TUNING

XM Satellite Radio is a satellite radio service with millions of listeners across the United States and Canada, broadcasting live daily. The XM Satellite Radio channel lineup includes over 160 digital channels of choice from coast to coast: 67 commercial-free music channels, featuring hip hop to opera, classical to country, bluegrass to blues; 33 channels of premier sports, talk, comedy, children's and entertainment programming; and more than 20 channels of the traffic and weather information for major metropolitan areas nationwide.

Because XM Satellite Radio is a subscription service, you will need to set up an account and activate service with XM using your XM Satellite Radio ID number. To check your ID number, follow "Activating XM Satellite Radio" on page 65. For further information on XM Satellite Radio services, visit the XM Satellite Radio website at "http://www.xmradio.com/" (for residents in the United States) or "http://www.xmradio.ca/" (for residents in Canada).

This unit is equipped with the Neural Surround decoder (U.S.A. and Canada models only) that plays back the surround sound content of the XM Satellite Radio broadcasts in multi-channels, resulting in a full surround sound experience.

## Notes

- The XM Satellite Radio service is only available in the 48 contiguous United States (not available in Alaska and Hawaii) and Canada.
- XM Passport System and monthly subscription are sold separately. For details, visit the XM Satellite Radio website at "http://www.xmradio.com/" (for residents in the United States) or "http://www.xmradio.ca/" (for residents in Canada).
- For information on obtaining the XM Passport System, visit the XM Satellite Radio website at "http://www.xmradio.com/" (for residents in the United States) or "http://www.xmradio.ca/" (for residents in Canada), or consult your local retailer that sells XM Ready products.
- To ensure optimal reception of the XM Satellite Radio signals, the XM Passport System must be placed at or near a southerly facing window with no obstacles in the path to the sky. You can mount it indoors or outdoors.

## Information from XM Satellite Radio Inc.

XM monthly service subscription sold separately. XM Passport and XM Passport Home Dock required to receive XM service (sold separately). Installation costs and other fees and taxes, including a one-time activation fee may apply. Subscription fee is consumer only. All fees and programming subject to change. Channels with frequent explicit language are indicated with an "XL". Channel blocking is available for XM radio receivers by calling "1-800-XM-RADIO (1-800-967-2346)" (for residents in the United States) or "1-877-GET-XMSR (1-877-438-9677)" (for residents in Canada). Subscriptions subject to Customer Agreement available at "http://www.xmradio.com/" (for residents in the United States) or "http://www.xmradio.ca/" (for residents in Canada). XM service only available in the 48 continuous United States and Canada. "XM Ready" is a trademark of XM Satellite Radio Inc. © 2006 XM Satellite Radio Inc. All rights reserved.

## Connecting the XM Passport System

Connect XM Passport and XM Passport Home Dock (sold separately) to the XM jack on the rear panel of this unit. For details, see the operating instructions provided with XM Passport System.

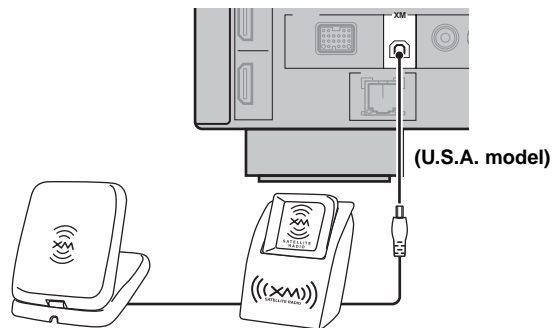

**XM Passport and XM Passport Home Dock (sold separately)**

# XM Satellite Radio controls and functions

**Note**

The following controls are available only when “XM” is selected as the input source. Rotate the INPUT selector on the front panel (or set the operation mode selector to SOURCE and then press XM on the remote control) to select “XM” as the input source.

■ **Front panel functions**

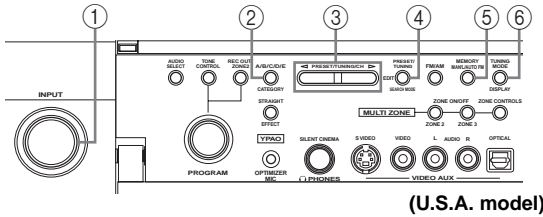

① **INPUT selector**

Selects “XM” as the input source.

② **CATEGORY**

**(All Channel Search mode)**

Changes the channel category while staying in the All Channel Search mode.

**(Category Search mode)**

Changes the channel category.

**(Preset Search mode)**

Changes the preset channel group (A to E).

③ **PRESET/TUNING/CH** ◀ / ▶

**(All Channel Search mode)**

Searches for a channel within all channels. Press and hold for quick search.

**(Category Search mode)**

Searches for a channel within the selected category. Press and hold for quick search.

**(Preset Search mode)**

Changes the preset channel number (1 to 8).

④ **SEARCH MODE**

Changes the search mode between the All Channel Search, Category Search, and Preset Search modes (see page 68).

⑤ **MEMORY**

Stores a preset channel in the memory (see page 72).

⑥ **DISPLAY**

Displays the XM Satellite Radio information such as channel number, channel name, category, artist name, or song title displayed in the front panel display or in the OSD (see page 73).

■ **Remote control functions**

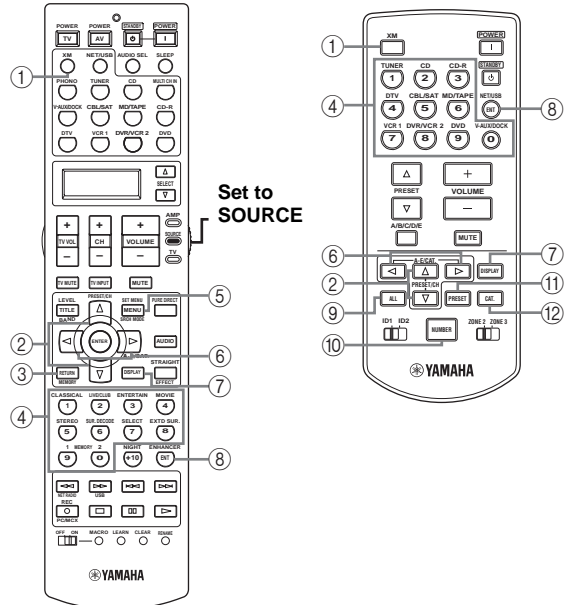

(U.S.A. model)

① **XM**

Selects “XM” as the input source.

② **PRESET/CH** Δ / ▽

**(All Channel Search mode)**

Searches for a channel within all channels. Press and hold for quick search.

**(Category Search mode)**

Searches for a channel within the selected category. Press and hold for quick search.

**(Preset Search mode)**

Changes the preset channel number (1 to 8).

③ **MEMORY**

Stores a preset channel in the memory (see page 72).

④ **Numeric buttons**

**(All Channel Search or Category Search mode)**

Use 1 to 9 and 0 to enter a channel number directly.

**(Preset Search mode)**

Use 1 to 8 to enter a preset channel number directly.

**⑤ SRCH MODE**

Changes the search mode between the All Channel Search, Category Search, and Preset Search modes (see page 68).

**⑥ A-E/CAT. </>****(All Channel Search mode)**

Changes the channel category.

**(Category Search mode)**

Changes the channel category.

**(Preset Search mode)**

Changes the preset channel group (A to E).

**⑦ DISPLAY**

Displays the XM Satellite Radio information such as channel number, channel name, category, artist name, or song title displayed in the front panel display or on the video monitor (see page 73).

**⑧ ENT**

Confirms an entered channel number in the Direct Number Access mode (see page 71).

**⑨ ALL**

Selects the All Channel Search mode (see page 68).

**⑩ NUMBER**

Press and hold before you press the input selector or numeric buttons to switch the function to entering numbers.

**⑪ PRESET**

Selects the Preset Search Mode (see page 70).

**⑫ CAT.**

Selects the Category Search mode (see page 69).

## Activating XM Satellite Radio

To sign up for an account with the XM Satellite Radio service, an XM Satellite Radio ID number is required. Follow the procedure below to check your ID number, and then visit the website or call toll-free with a major credit card handy for signing up.

**For residents in the United States**

URL: <http://activate.xmradio.com/>

Toll-free: 1-800-XM-RADIO (1-800-967-2346)

**For residents in Canada**

URL: <https://activate.xmradio.ca/on-line-activation/activation.jsp>

Toll-free: 1-877-GET-XMSR (1-877-438-9677)

(U.S.A. model)

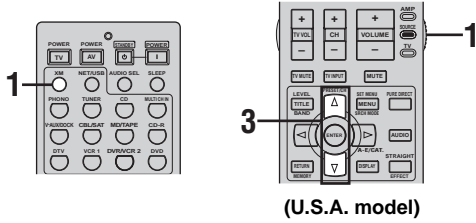
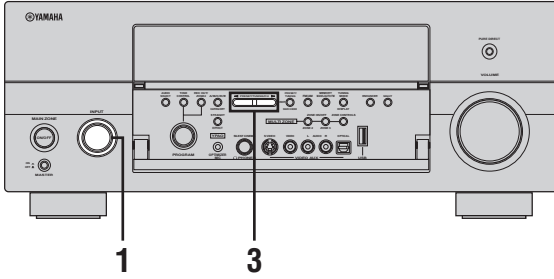

(U.S.A. model)

- 1 Rotate the INPUT selector on the front panel (or set the operation mode selector to SOURCE and then press XM on the remote control) to select “XM” as the input source.**  
The cursor on the left of the XM indicator lights up in the front panel display.

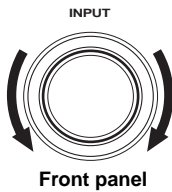

Front panel

or



Remote control

Lights up

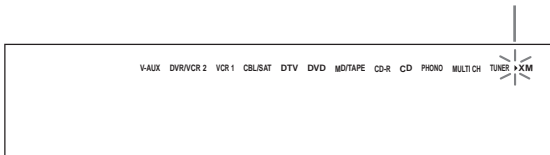

- 2 Check the XM Satellite Radio reception level and adjust the orientation of XM Passport System for a better percentage of the reception level.**



You can display the XM Satellite Radio reception level by using the “Antenna Level” parameter in “Input Select” (see page 94).

**Notes**

- If “CHECK ANTENNA” appears in the front panel display, XM Passport System may not be connected to the XM jack on the rear panel of this unit properly. See “Connecting the XM Passport System” on page 63 and check the connection.
- The “Antenna Level” parameter in “Input Select” (See page 94) cannot be adjusted by using the remote control. Instead, you need to adjust the orientation of XM Passport System connected to the XM jack of this unit for a better percentage of the reception level.

- 3 Press PRESET/TUNING/CH </> on the front panel (or PRESET/CH Δ / ▽ on the remote control) to select channel “0”.**

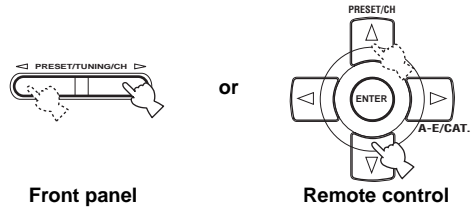

Front panel

Remote control

**Note**

You cannot select channel “0” if the All Channel Search mode (see page 68) is not selected.

- 4 Check the XM Satellite Radio ID number displayed in the front panel display and write it down.**

ID: \_\_\_\_\_

# Basic XM Satellite Radio operations

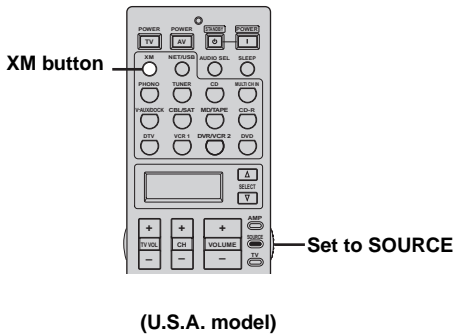
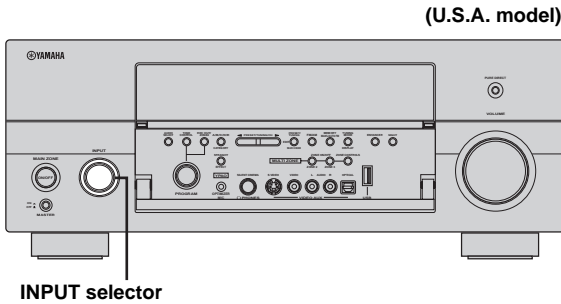

**1 Rotate the INPUT selector on the front panel (or set the operation mode selector to SOURCE and then press XM on the remote control) to select “XM” as the input source.**

The cursor on the left of the XM indicator lights up in the front panel display and the XM Satellite Radio information (such as channel number, channel name, category, artist name, or song title) for the currently selected channel appears in the front panel display.

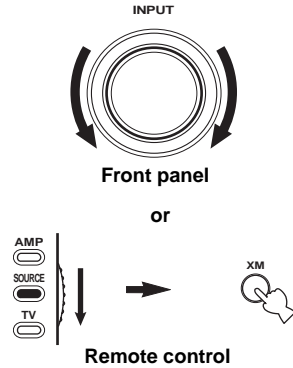

Lights up

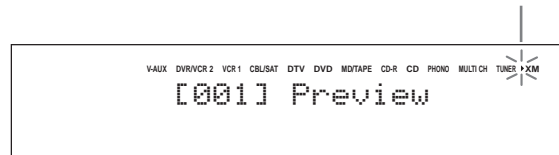

When you select “XM” as the input source, this unit automatically recalls the previously selected channel.

**Note**

The XM Satellite Radio signals cannot be output at the AUDIO OUT (REC) jacks.

**2 Search for a channel by using one of the XM Satellite Radio search modes.**

- To select a channel from the all channel list, see “All Channel Search mode” on page 68.
- To select a channel by category, see “Category Search mode” on page 69.
- To select a channel from the preset channels, see “Preset Search mode” on page 70.
- To select the desired channel directly by entering the channel number, see “Direct Number Access mode” on page 71.



- You can use the Neural Surround decoder to enjoy the surround sound content of XM Satellite Radio broadcasts in multi-channels (see page 84).
- You can set the XM Satellite Radio preset channels (see page 72).
- You can display the XM Satellite Radio information in the front panel display or on the video monitor (see page 73).

■ All Channel Search mode

(U.S.A. model)

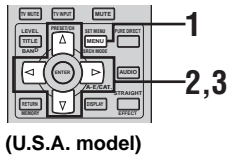
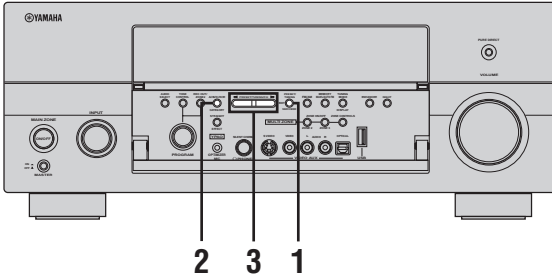

**1** Press **SEARCH MODE** on the front panel (or **SRCH MODE** on the remote control) repeatedly to select “ALL CH SEARCH”.

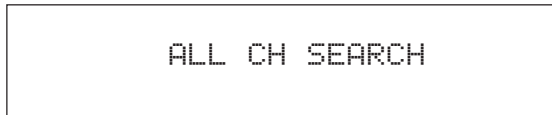
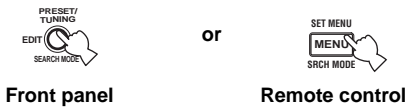

**2** Press **CATEGORY** on the front panel (or **A-E/CAT**.  $\triangleleft$  /  $\triangleright$  on the remote control) repeatedly to change the channel category.

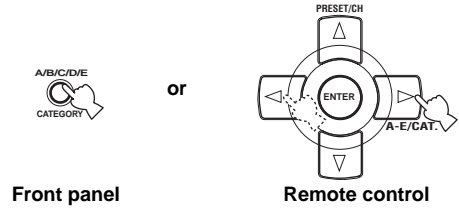

**3** Press **PRESET/TUNING/CH**  $\triangleleft$  /  $\triangleright$  on the front panel (or **PRESET/CH**  $\triangle$  /  $\nabla$  on the remote control) repeatedly to search for a channel within all channels.

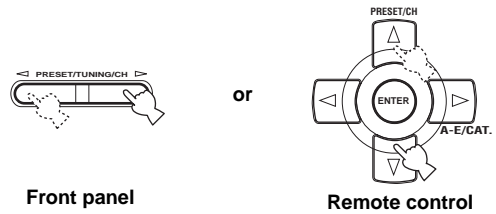

You can search for a channel quickly by pressing and holding **PRESET/TUNING/CH**  $\triangleleft$  /  $\triangleright$  on the front panel (or **PRESET/CH**  $\triangle$  /  $\nabla$  on the remote control).



■ Category Search mode

(U.S.A. model)

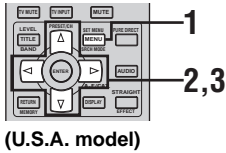
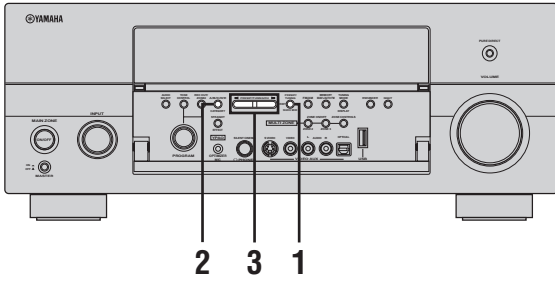

- 1** Press **SEARCH MODE** on the front panel (or **SRCH MODE** on the remote control) repeatedly to select “CAT SEARCH”.

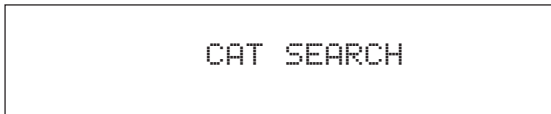
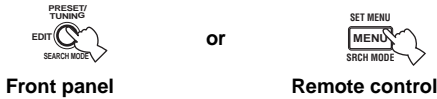

- 2** Press **CATEGORY** on the front panel (or **A-E/CAT.**  $\triangleleft$  /  $\triangleright$  on the remote control) repeatedly to change the channel category.

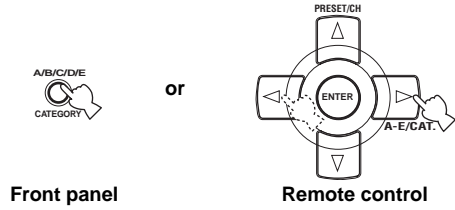

- 3** Press **PRESET/TUNING/CH**  $\triangleleft$  /  $\triangleright$  on the front panel (or **PRESET/CH**  $\triangle$  /  $\nabla$  on the remote control) repeatedly to search for a channel within the selected channel category.

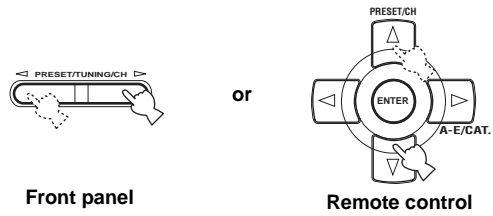

You can search for a channel quickly by pressing and holding **PRESET/TUNING/CH**  $\triangleleft$  /  $\triangleright$  on the front panel (or **PRESET/CH**  $\triangle$  /  $\nabla$  on the remote control).

**■ Preset Search mode**

Prior to selecting a preset channel in the Preset Search mode, you must preset XM Satellite Radio channels. For details, see “Setting the XM Satellite Radio preset channels” on page 72.



The initial factory setting of all preset channels (A1 to E8) is “[001] Preview”.

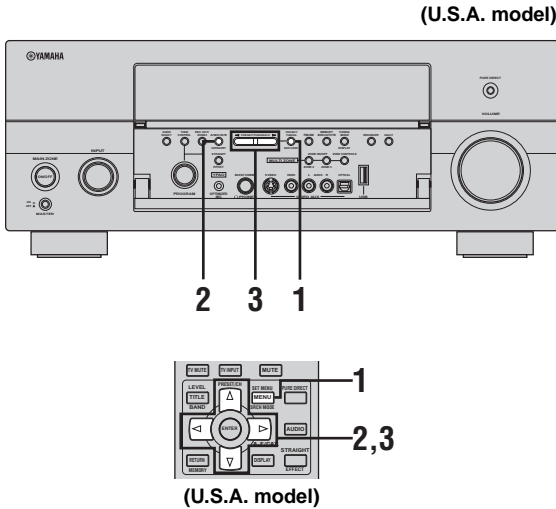

- 1 Press SEARCH MODE on the front panel (or SRCH MODE on the remote control) repeatedly to select “PRESET SEARCH”.**

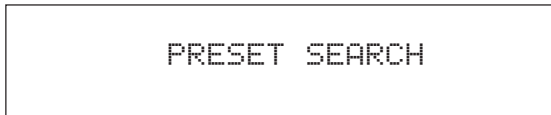
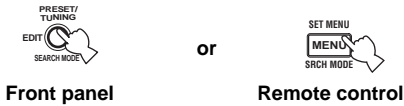

- 2 Press CATEGORY on the front panel (or A-E/CAT. </> on the remote control) repeatedly to change the preset channel group (A to E).**

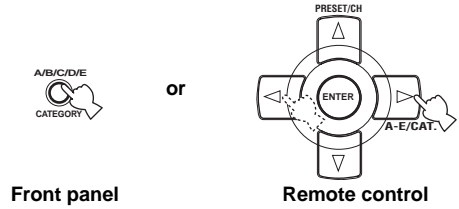

- 3 Press PRESET/TUNING/CH </> on the front panel (or PRESET/CH Δ / ▽ on the remote control) repeatedly to change the preset channel number (1 to 8).**

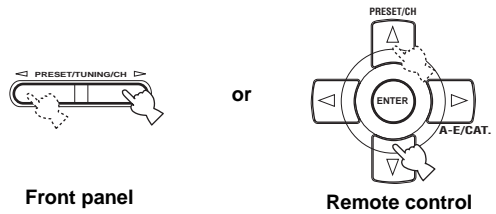

You can also select the preset channel number directly by pressing the numeric buttons (1 to 8) on the remote control.

■ Direct Number Access mode

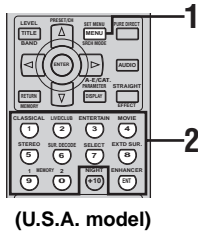

1 Press SRCH MODE on the remote control repeatedly to select “ALL CH SEARCH” or “CAT SEARCH”.

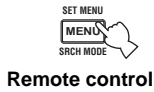

ALL CH SEARCH

or

CAT SEARCH

2 Press the numeric buttons on the remote control to enter the desired three-digit channel number.

For example, to enter the number 123, press the numeric buttons as shown below.



The display changes as follows.

<XM> --1

<XM> -12

<XM>123



- To enter a one-digit or two-digit channel number, press the numeric buttons on the remote control and then press ENT to confirm the input number.
- Instead of pressing ENT to tune into the channel immediately, you can wait a few seconds until this unit confirms the entered channel number.
- If no button is pressed within a few seconds after you enter a one-digit or two-digit number, this unit automatically confirms the entered channel number.
- Pressing a button other than the numeric buttons or ENT cancels the Direct Number Access mode procedure.

## Setting the XM Satellite Radio preset channels

You can use this feature to store up to 40 XM Satellite Radio channels (A1 to E8: 8 preset channel numbers in each of the 5 preset channel groups). You can then recall any preset channel easily by selecting the preset channel group and number as described in “Preset Search mode” on page 70.

(U.S.A. model)

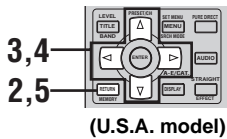
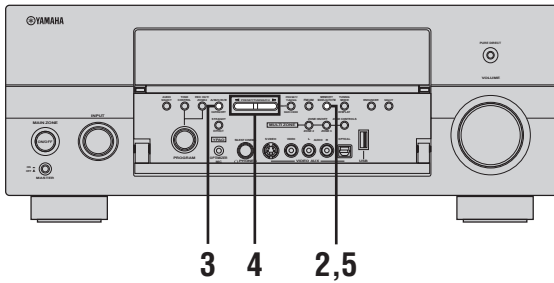

### 1 Search for a channel you want to set as a preset channel by using one of the XM Satellite Radio search modes.

See “Basic XM Satellite Radio operations” on page 67 for details.

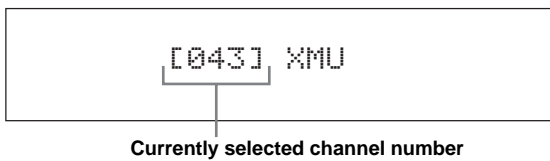

### 2 Press MEMORY on the front panel (or MEMORY on the remote control).

The MEMORY indicator flashes in the front panel display for approximately 5 seconds.

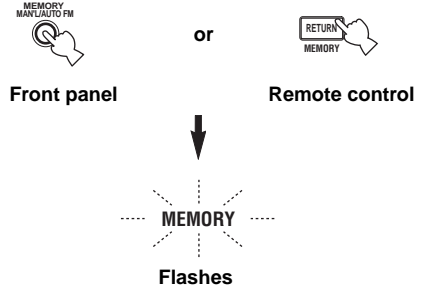

**Note**

You must proceed to and carry out steps 3 through 5 while the MEMORY indicator is flashing in the front panel display.

### 3 Press CATEGORY on the front panel (or A-E/CAT. </> on the remote control) repeatedly to select a preset channel group (A to E) while the MEMORY indicator is flashing.

The preset channel group letter appears in the front panel display.

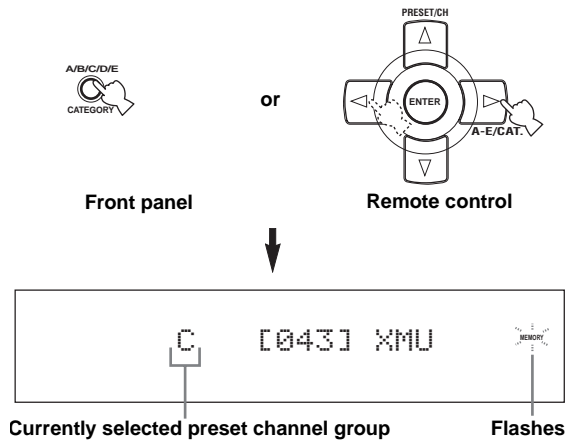

- 4** Press PRESET/TUNING/CH ◀/▶ on the front panel (or PRESET/CH ▲/▼ on the remote control) repeatedly to select a preset channel number (1 to 8) while the MEMORY indicator is flashing.

The preset channel number appears in the front panel display.

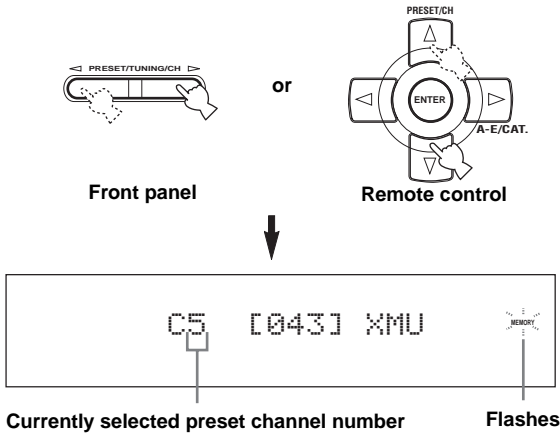

- 5** Press MEMORY on the front panel (or MEMORY on the remote control) to set the selected XM Satellite Radio channel as a preset channel while the MEMORY indicator is flashing.

A colon (:) appears next to the preset channel number for confirmation, and the MEMORY indicator turns off in the front panel display.

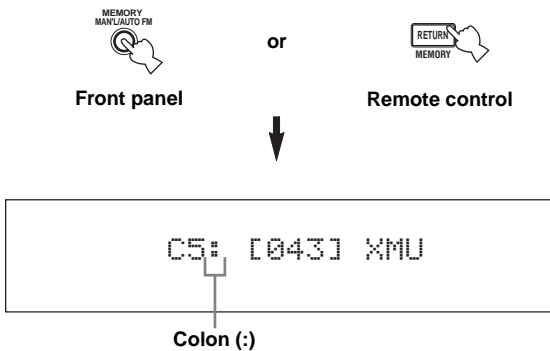

**Note**

Once you set a new preset channel, the one previously stored in the same preset channel group and number is cleared.

## Displaying the XM Satellite Radio information

You can display the XM Satellite Radio information (such as channel number, channel name, category, artist name, or song title) for the currently selected channel in the front panel display or in the OSD.

(U.S.A. model)

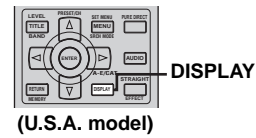
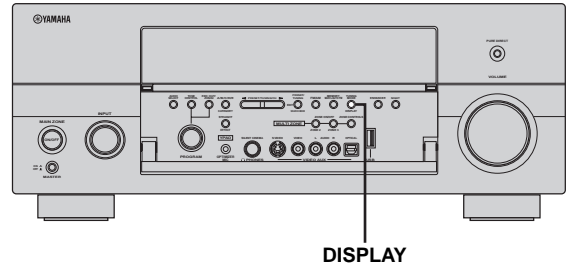

(U.S.A. model)

**Note**

If a status message or an error message appears in the front panel display or on the video monitor, see the “XM Satellite Radio (U.S.A. and Canada models only)” section in “TROUBLESHOOTING” on page 139 for appropriate remedies.

### ■ Displaying the XM Satellite Radio information in the front panel display

Press DISPLAY on the front panel or on the remote control repeatedly to toggle between the following XM Satellite Radio information display modes.

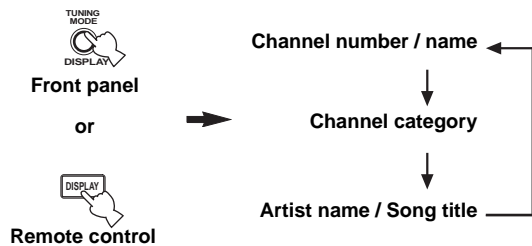

When the channel number / name is displayed:

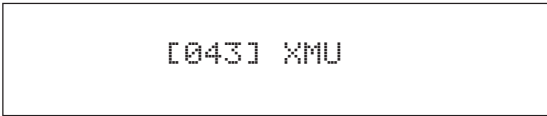

When the channel category is displayed:

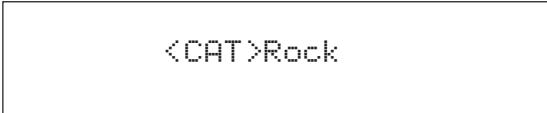

When the artist name / song title is displayed:

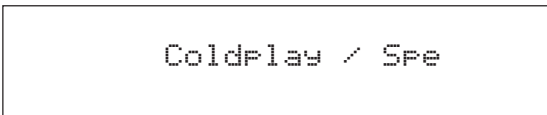

- The front panel display can indicate up to 14 alphanumeric characters at once. You can set whether to display the XM Satellite Radio information in the front panel display in a continuous manner or by 14 alphanumeric characters at once by using the “Scroll” parameter in “Front Panel Disp.” (see page 112).
- If the XM Satellite Radio information contains a character that cannot be recognized by this unit, the character will be displayed with a space.

**Note**

If you press DISPLAY while the XM Satellite Radio information display is scrolling from right to left in the front panel display, the XM Satellite Radio information display mode toggles as described above.

■ **Displaying the XM Satellite Radio information on the video monitor**

Press **DISPLAY** on the remote control.

The following information screen is displayed on the video monitor.

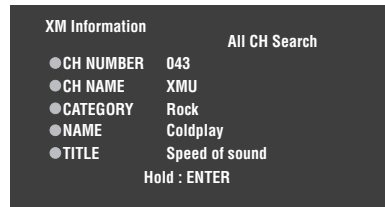
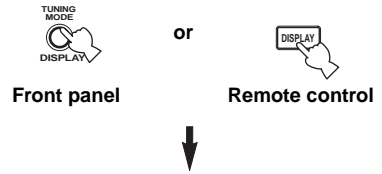

- To turn off the displayed information screen, press DISPLAY on the front panel (or on the remote control).
- You can select the amount of time the XM Satellite Radio information is displayed in on the video monitor by using the “On Screen” parameter in “Manual Setup” (see page 103).
- To hold the XM Satellite Radio information screen, press ENTER on the remote control while it is being displayed on the video monitor.
- The XM Satellite Radio information screen on hold is released if you press ENTER on the remote control again or if you change the XM Satellite Radio channel.
- This unit can save up to two XM Satellite Radio information screens for future reference. To view the previous two XM Satellite Radio information screens, press TITLE on the remote control repeatedly while the current XM Satellite Radio information screen is being hold.

# USING iPod

Once you have stationed your iPod in a YAMAHA iPod universal dock (such as the YDS-10, sold separately) connected to the DOCK terminal of this unit (see page 29), you can enjoy playback of your iPod using the supplied remote control. You can also use the Compressed Music Enhancer mode of this unit to improve the sound quality of the compression artifacts (such as the MP3 format) stored on your iPod (see page 54).

## Notes

- Only iPod (Click and Wheel), iPod nano, and iPod mini are supported.
  - Some features may not be compatible depending on the model or the software version of your iPod.
- 
- For a complete list of the remote control functions used to control your iPod, see the “iPod” column in “Controlling other components” on page 119.
  - For a complete list of status messages that appear in the front panel display and on the video monitor, see the “iPod” section in “TROUBLESHOOTING” on page 147.
  - Once your iPod is stationed in a YAMAHA iPod universal dock (such as the YDS-10, sold separately) connected to the DOCK terminal of this unit, this unit begins signal transmission with your iPod.
  - Once the connection between your iPod and this unit is complete, “iPod connected” appears in the front panel display and the DOCK indicator lights up in the front panel display.
  - Only the analog audio and video signals of your iPod are input at the DOCK terminal, and the analog audio signals can be output at the analog AUDIO OUT (REC) jacks for recording.
  - Your iPod battery is automatically charged when your iPod is stationed in a YAMAHA iPod universal dock (such as the YDS-10, sold separately) connected to the DOCK terminal of this unit as long as this unit is turned on. You can also select whether this unit charges the battery of the stationed iPod or not when this unit is in the standby mode by selecting the “Standby Charge” parameter in “iPod” (see page 104).
  - While the stationed iPod is being charged in the standby mode of this unit, the battery charge indicator (see page 12) appears in the front panel display. Once the charge is complete (or after 4 hours from the start of the charge), the indicator disappears.

## Controlling iPod

You can control your iPod when “V-AUX” is selected as the input source. The operations of your iPod can be done with the aid of the GUI screen of this unit (menu browse mode) or without it (simple remote mode).

### ■ Controlling iPod in the simple remote mode

You can perform the basic operations of your iPod (play, stop, skip, etc.) using the supplied remote control without the aid of the GUI screen of this unit.



- You can view the photos or video clips stored on your iPod.
- Operations can be also done with the controls on your iPod.

### ■ Controlling iPod in the menu browse mode

You can perform the advanced operations of your iPod using the supplied remote control with the aid of the GUI screen of this unit. The name of the song being played appears in the front panel display according to the “Scroll” parameter in “Front Panel Disp.” (see page 112). You can also browse the songs stored on your iPod in the GUI screen. Further, you can change or adjust settings for your iPod to suit your personal preferences.

## Notes

- Operations cannot be done with the controls on your iPod.
- The YAMAHA logo appears in the display window of your iPod.
- There are some characters that cannot be displayed in the front panel display or in the GUI screen of this unit. Those characters are replaced with underscores “\_”.
- The “Settings” parameters can be changed or adjusted only in the GUI screen. Press ENTER on the remote control to toggle between the “Settings” parameter settings.
- You cannot browse the photos or video clips stored on your iPod in the GUI screen. Instead, you must use the controls on your iPod to select the desired photos or video clips.
- You can select the amount of time the GUI screen of iPod is displayed in on the video monitor by using the “On Screen” parameter in “Manual Setup” (see page 103).

**1 Set the operation mode selector to SOURCE and then press DISPLAY on the remote control.**

The following display appears in the video monitor.

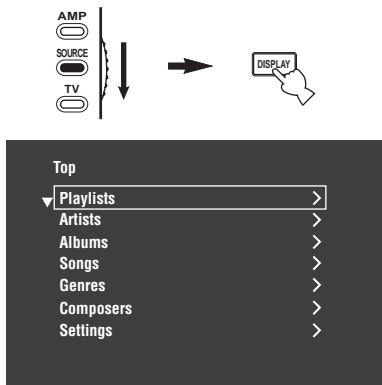

**2 Press  $\Delta$  /  $\nabla$  /  $\leftarrow$  /  $\rightarrow$  on the remote control to navigate the iPod menu and then press ENTER to begin playback of the selected song.**

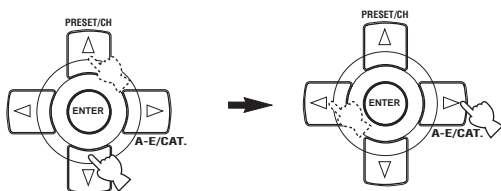

Choices: Playlists (playlists), Artists (artists), Albums (albums), Songs (songs), Genres (genres), Composers (composers), Settings (settings)

- Playlists > Songs
- Artists > Albums > Songs
- Albums > Songs
- Songs
- Genres > Artists > Albums > Songs
- Composers > Albums > Songs
- Settings > Shuffle, Repeat

**Shuffle (Shuffle)**

Use this feature to set this unit to play songs or albums in random order.

Choices: **Off**, Songs, Albums

- Select “Off” to deactivate this feature.
- Select “Songs” to set this unit to play songs in random order.
- Select “Albums” to set this unit to play albums in random order.

**Note**

When “Shuffle” is set to a setting other than “Off”, “ $\square$ ” appears in the top right corner while songs or albums are being shuffled.

**Repeat (Repeat)**

Use this feature to set this unit to repeat one song or a sequence of songs.

Choices: **Off**, One, All

- Select “Off” to deactivate this feature.
- Select “One” to set this unit to repeat one song.
- Select “All” to set this unit to repeat a sequence of songs.

**Note**

When “Repeat” is set to a setting other than “Off”, “ $\square$ ” or “ $\square$ ” appears in the top right corner while one song or a sequence of songs are being repeated.

**■ The functions of the play information display**

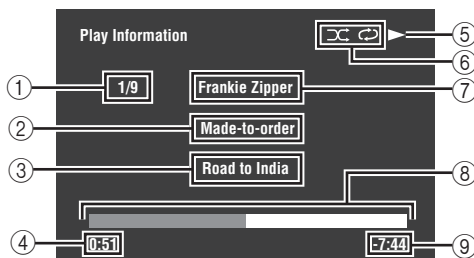

- ① Track number/total tracks
- ② Name of the album
- ③ Name of the song
- ④ Elapsed time
- ⑤  $\triangleright$  (playback) or  $\square$  (pausing)
- ⑥ Shuffle and repeat icons
- ⑦ Name of the artist
- ⑧ Progress bar
- ⑨ Remaining time



# USING NETWORK/USB FEATURES

This unit is equipped with network and USB features that allow you to enjoy WAV (PCM format only), MP3 and WMA files saved on your PC, YAMAHA MCX-2000, USB memory device and USB portable audio player or access the Internet Radio.

## Notes

- YAMAHA MCX-2000 may not be for sale in some locations.
- For further details about networking, refer to the operation manuals supplied with your network devices. Also refer to technical reference books, if needed.
- Some WAV, MP3 and WMA files may not be playable or may be noisy when played.



- For a complete list of the remote control functions used to control the network and USB features, see the “PC/MCX-2000/Internet Radio/USB” column in “Controlling other components” on page 119.
- For a complete list of status messages that appear in the front panel display and on the video monitor, see the “Network and USB” section in “TROUBLESHOOTING” on page 144.

## Navigating the network and USB menus

The following diagram shows the construction of the network and USB menu.

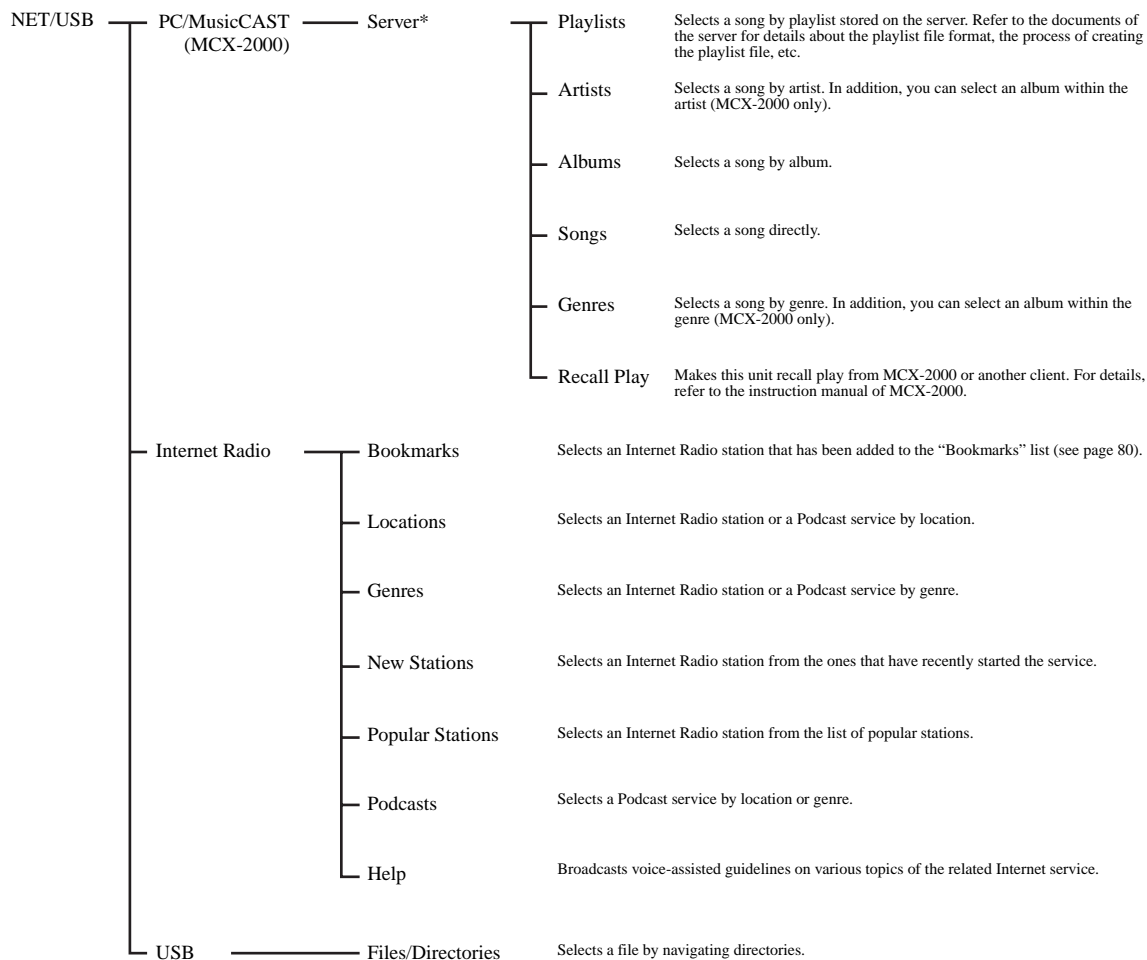

## Note

\* Only the available PC servers and MCX-2000 are displayed.

The following procedure shows the basic steps to navigate the network and USB menus. See pages 79 and 80 for details about each sub input source.

**Note**

“Please wait” may appear whenever it takes time for communication. This is not a system malfunction. Wait for a while.

**1 Set the operation mode selector to SOURCE and then press NET/USB on the remote control to select “NET/USB” as the input source.**

The cursor on the left of the NET/USB indicator lights up in the front panel display, and the contents previously played for the corresponding sub input source of NET/USB is automatically played.



Lights up

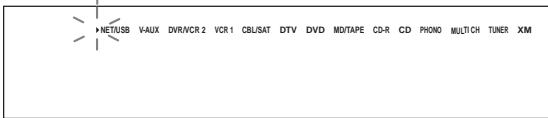

**2 Press DISPLAY on the remote control to display the top NET/USB menu.**

The following display appears on the video monitor. If any other screen appears on the video monitor, press MENU on the remote control repeatedly until the top NET/USB menu appears.

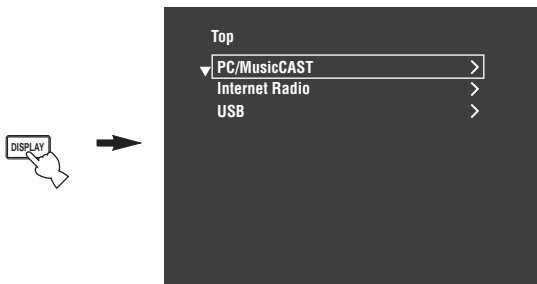

**3 Press  $\Delta$  /  $\nabla$  to select the desired sub input source and then press  $\triangleright$  or ENTER.**



You can also select the desired sub input source by pressing the corresponding button on the remote control (see page 8).

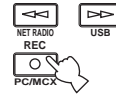

**4 Press  $\Delta$  /  $\nabla$  /  $\triangleleft$  /  $\triangleright$  on the remote control to select the desired song or Internet Radio station.**

- Press  $\Delta$  /  $\nabla$  to select the desired menu.
- Press  $\triangleright$  to enter the selected menu.
- Press  $\triangleleft$  to return to the previous menu level.



- “ $\triangleright$ ” in the right corner of each menu line indicates that there is a submenu available in the next menu level.
- You can press ENTER or MENU to enter the selected menu or to return to the previous menu level.

**5 Press ENTER to play the selected song or to listen to the selected station.**



- See page 76 for details about the functions of the play information display.
- Some items do not appear in the play information display depending on the selected sub input source.

## Using a PC server or YAMAHA MCX-2000

Use this feature to enjoy music files saved on your PC or YAMAHA MCX-2000. MCX-2000 is a music server that enhances the concept of YAMAHA exclusive MusicCAST, a digital music delivery method over a personal network.

### 1 Install Windows Media Connect 2.0 on your PC, or register this unit on your YAMAHA MCX-2000.

- Refer to “Installing Windows Media Connect 2.0 on your PC” on page 79 and “Registering this unit on the YAMAHA MCX-2000” on page 80.
- This procedure is needed only the first time.

### 2 Turn on your PC or MCX-2000.

The PC server or MCX-2000 is added to the server list on the submenu of PC/MusicCAST.

### 3 Select a desired server or MusicCAST to begin playback.

#### Notes

- YAMAHA MCX-2000 may not be for sale in some locations.
- You can connect this unit to up to 4 PC servers and 1 MCX-2000, and each server must be connected to the same subnet as this unit.
- Some WAV, MP3 and WMA files on your PC may not be playable or may be noisy when played.
- (MCX-2000 only) Files marked with an asterisk (\*) have not been converted to MP3 format. You cannot play back such files immediately unless you set the “Receive PCM Stream” setting of this unit to “ON” on MCX-2000. For details, refer to the instruction manual of MCX-2000.



- While a song is being played, the time elapsed is displayed at the bottom of the playback information screen.
- You can use / to skip backward/forward and / to start/stop playback independently from the menu on the video monitor.
- You can set the settings for repeat and shuffle mode by using the “Play Style” parameters in “NET/USB” (see page 110).
- You can set whether to display the operation status in the front panel display in a continuous manner or by the first 14 characters after scrolling all characters once by using “Scroll” in “Front Panel Disp.” (see page 112).

## ■ Installing Windows Media Connect 2.0 on your PC

With Windows Media Connect 2.0, you can play back the audio files on your PC. For details refer to the documents of Windows Media Connect 2.0.

### 1 Install Windows Media Connect 2.0 on your PC.

You can download the installer of Windows Media Connect 2.0 from the Microsoft website.

### 2 Turn on your PC and then share a folder on the PC.

The Shared folder is added to the server list on the submenu of PC/MusicCAST.

#### Notes

- Some security software installed on your PC (anti-virus software, firewall software, etc.) may block the access of this unit to your PC. In such cases, configure the security software appropriately.
- If you are using a PC with Windows XP Professional, and the PC is logging on to a domain, you may not be able to connect the PC server. In such cases, log on to the local machine instead of the domain.

## ■ Registering this unit on the YAMAHA MCX-2000

You must register this unit on your YAMAHA MCX-2000 so that this unit can be recognized by your YAMAHA MCX-2000. For details, refer to the operation manual supplied with your YAMAHA MCX-2000.

### 1 Turn off this unit.

### 2 Set your YAMAHA MCX-2000 to the “Auto Config” mode.

### 3 Turn on this unit.

- MCX-2000 is added to the server list on the submenu of PC/MCX.
- The client ID of this unit appears in the OSD of your YAMAHA MCX-2000 (shown as CL-XXXXX), and this completes the automatic configuration procedure.

#### Notes

- The latter part of the client ID of this unit is same as the last 5 digits of the MAC address of this unit. For details about MAC address, see page 111.
- To clear the registered client ID of this unit, use the “Manual Config” mode of your YAMAHA MCX-2000 (refer to the instruction manual of MCX-2000) and then set “N-RESET” in the advanced setup menu of this unit to “RESET” (see page 136).
- The client control functions of MusicCAST over this unit other than “View Play Info”, “Receive PCM Stream” and “Edit Client title” are not available. Avoid using these functions as it will stop the playback on this unit.

## Using the Internet Radio

Use this feature to listen to Internet Radio stations. This unit uses the vTuner Internet Radio station database service particularly customized for this unit, providing over 2000 radio station database. Further, you can store your favorite stations with bookmarks.

#### Notes

- This service may be discontinued without notice.
- Some Internet Radio stations may not be played even if they are selected in the NET RADIO menu.
- To listen to the Internet Radio, connect this unit to your network (see page 30).
- A narrowband Internet connection (i.e. 56K modem, ISDN) will not provide satisfactory results, and a broadband connection is strongly recommended (i.e. a cable modem, an xDSL modem, etc.). For detailed information, consult with your ISP.



- You can use  $\triangleright$  /  $\square$  to start/stop playback independently from the menu on the video monitor.
- “Podcast” is a type of the Internet Radio service, and there are a number of Podcast services available on the Internet. The Podcast is not a continuous service. That is, this unit stops playback when an episode of the Podcast ends.
- Some security devices (such as firewall) may block the access of this unit to Internet Radio stations. In such cases, configure the security settings appropriately.

## ■ Storing your favorite Internet Radio stations with bookmarks

Use this feature to select your favorite Internet Radio stations quickly.

**Press and hold TITLE on the remote control while the selected Internet Radio station service is being broadcast.**

The stored Internet Radio station is added to the “Bookmarks” list (see page 77).



To remove the stored station from the list, select the item in the first level of the “Bookmarks” list and then press and hold TITLE on the remote control.

## Using a USB memory device or a USB portable audio player

Use this feature to enjoy WAV (PCM format only), MP3 and WMA files saved on your USB memory device or USB portable audio player connected to the USB port on the front panel of this unit.

### Notes

- This unit supports USB mass storage class devices using FAT 16 or FAT 32.
- Only the first partition is displayed in the GUI menu. You cannot select files in other partitions.
- Up to 8 levels of directory hierarchy and 500 music files per directory are recognized.
- Some devices may not work properly even if they meet the requirements.
- Some WAV, MP3 and WMA files may not be playable or may be noisy when played.
- When you connect your USB memory device or USB portable audio player, there may be an about 10 seconds delay.



- While a song is being played, the time elapsed is displayed at the bottom of the playback information screen.
- You can use / to skip backward/forward and / to start/stop playback independently from the menu in the OSD.
- You can set the settings for repeat and shuffle mode by using the "Play Style" parameters in "NET/USB" (see page 110).
- You can set whether to display the operation status in the front panel display in a continuous manner or by the first 14 characters after scrolling all characters once by using "Scroll" in "Front Panel Disp." (see page 112).

### Connecting a USB memory device or a USB portable audio player

Connect a USB jack of a USB memory device or USB portable audio player to the USB port on the front panel of this unit.

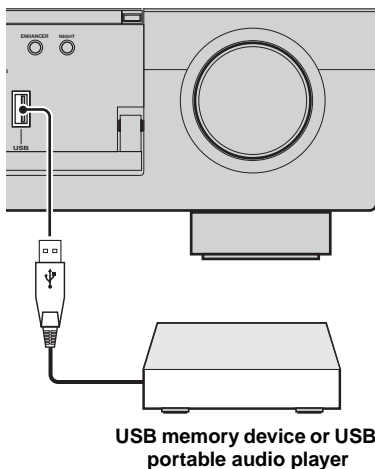

## Using shortcut buttons

Use this feature to access the desired music sources (WAV, MP3 and WMA files on the connected PC, MCX-2000 or USB storage devices and Internet Radio stations) directly. You can preset 8 items in each sub input sources.

### Assigning the items to the numeric button (1-8)

- 1 Set the operation mode selector to SOURCE and then press NET/USB on the remote control to select "NET/USB" as the input source.**



- 2 Select a desired music source you want to assign to the numeric button (1-8), and then play back the source.**

See page 78 for details.

- 3 Press MEMORY.**

This unit in the memory preset mode. The MEMORY indicator flashes and following message appears in the video monitor and front panel display.

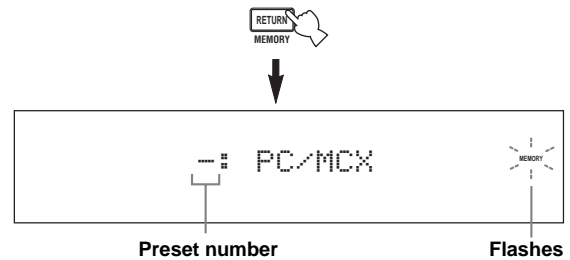

When you do not complete each of the following steps within 5 seconds, the memory preset mode is automatically canceled. In this case, start over from step 3.

**4 Press desired numeric buttons (1-8).**

The number of the selected numeric button appears in the video monitor or front panel display.

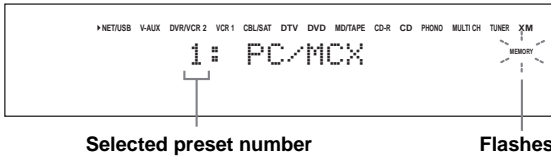

**3 Press one of the numeric button (1-8) which the desired item is assigned to select the item as the input source.**

The selected preset number appears in the front panel display, and this unit starts the playback of the source assigned to the selected numeric button.

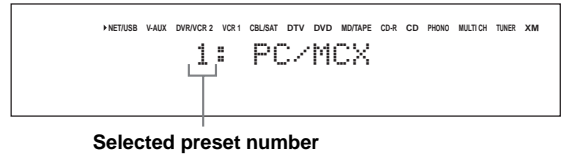
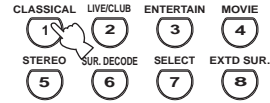

**5 Press ENTER or MEMORY to confirm the preset.**

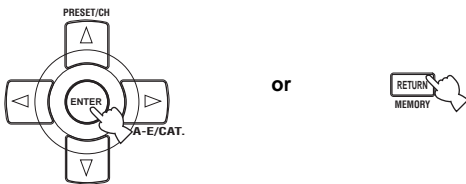

**Select an item by using numeric buttons (1-8)**

**1 Set the operation mode selector to SOURCE and then press NET/USB on the remote control to select "NET/USB" as the input source.**



**2 Select the desired sub input source.**

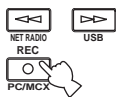

**Notes**

- "Empty Memory!" appears in the front panel display and the short message display when you press the numeric button (1-8) to which no items are assigned.
- This unit does not recall the correct item assigned to the selected numeric button (1-8) in the following cases:
  - the connected USB device is incorrect.
  - the PC or MCX-2000 which stores the selected item is turned off or disconnected from the network.
  - the selected Internet Radio station is temporary unavailable or out of service.
  - the directory of the selected item has been changed.



This unit stores the relative position of the preset items in a directory or playlist, and does not recall the correct item by using numeric buttons (1-8) if you add or delete music files to or from the same directory or playlist as the preset items. In such cases, preset the desired item to the numeric buttons (1-8) again.

We recommend the following methods:

**PC server/MCX-2000**

Create eight playlists which contain desired items, and then preset the top item of each playlist to the numeric buttons (1-8). When you change the items which are preset to the numeric buttons (1-8), replace the registered items in the playlist with the desired items without deleting the playlist.

**USB devices**

Create eight directories which contain desired items in a directory beside the directory which contains all music files, and then preset the top item of each directory to the numeric buttons (1-8). When you change the items which are preset to the numeric buttons (1-8), replace the items in the directory to the desired items without deleting the directory.

# RECORDING

Recording adjustments and other operations are performed from the recording components. Refer to the operating instructions for those components.

## CAUTION

The DTS signal is a digital bitstream. Attempting to digitally record the DTS bitstream will result in noise being recorded. Therefore, if you want to use this unit to record sources encoded in DTS, the following considerations and adjustments need to be made. To play DTS-encoded DVDs and CDs (when using a digital audio connection) on your DTS-compatible player, follow its operating instructions to make a setting so that the analog signal will be output from the player.

## Notes

- When this unit is set to the standby mode, you cannot record between other components connected to this unit.
- The settings of TONE CONTROL (see page 52), VOLUME, the speaker level (see page 109) and the sound field programs (see page 47) do not affect recorded material.
- The source connected to the MULTI CH INPUT jacks of this unit cannot be recorded.
- The XM Satellite Radio signals (U.S.A. and Canada models only) cannot be output at the AUDIO OUT (REC) jacks.
- Digital signals input at the DIGITAL INPUT jacks are not output at the analog AUDIO OUT (REC) jacks for recording. Likewise, analog signals input at the AUDIO IN jacks are not output at the DIGITAL OUTPUT jack. Therefore, if your source component is connected to provide only digital or analog signals, you can only record digital or analog signals.
- A given input source is not output on the same OUT (REC) channel.
- S-video and composite video signals pass independently through the video circuits of this unit. Therefore, when recording or dubbing video signals input from a video source component that provides only an S-video or a composite video signal, you can record only an S-video or a composite video signal on your VCR.
- The analog audio signals input at the DOCK terminal can be output at the analog AUDIO OUT (REC) jacks for recording.
- Check the copyright laws in your country to record from CDs, radio, etc. Recording of copyrighted material may infringe copyright laws.



Do a test recording before you start an actual recording.

If you play back a video source that uses scrambled or encoded signals to prevent it from being dubbed, the picture itself may be disturbed due to those signals.

(U.S.A. model)

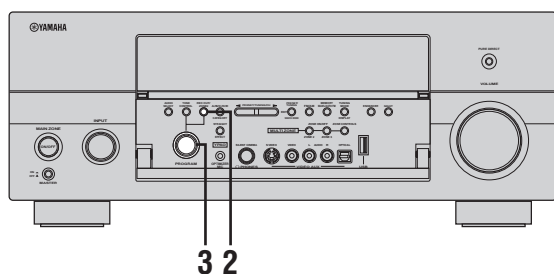

- 3 Rotate the PROGRAM selector on the front panel to select the source component you want to record from.

Select "SOURCE" to record the currently selected input source.



Front panel

- 1 Turn on all the connected components.

- 2 Press REC OUT/ZONE 2 repeatedly until the RECOUT indicator lights up in the front panel display.



- 4 Start playback on the selected source component or select a broadcast station.

- 5 Start recording on the recording component.

# ADVANCED SOUND CONFIGURATIONS

## Selecting decoders

### ■ Selecting decoders for 2-channel sources (surround decode mode)

Use this feature to play back sources with selected decoders. You can play back 2-channel sources on multi-channels.

- 1 Set the operation mode selector to AMP and then press SUR. DECODE on the remote control to select the surround decode mode.



- 2 Press SELECT on the remote control repeatedly to select the desired decoder.

You can select from the following modes depending on the type of source you are playing and your personal preference.



- You can select the desired decoder by pressing SELECT and then press <◀/▶> repeatedly on the remote control.
- You can select the desired decoder and adjust the decoder parameter settings by using GUI screen. See page 88 for details.

### ■ Decoder descriptions

Remote control button	Category of the program	Name of the decoder (Decoder Type)		
SUR.DECODE 6	SUR. DECODE	PL IIX Music PL II Music		
Dolby Pro Logic IIX (or Dolby Pro Logic II) processing for music sources. The Pro Logic IIX decoder is not available when "Surround Back" is set to "None" (see page 106).				
Panorama	Dimension	Center Width		
Available sound field parameters (see page 89)			Program description	

SUR.DECODE 6	SUR. DECODE	PRO LOGIC		
Dolby Pro Logic processing for any sources.				
SUR.DECODE 6	SUR. DECODE	PLIIX Movie PL II Movie		
Dolby Pro Logic IIX (or Dolby Pro Logic II) processing for movie sources. The Pro Logic IIX decoder is not available when "Surround Back" is set to "None" (see page 106).				
SUR.DECODE 6	SUR. DECODE	PLIIX Music PL II Music		
Dolby Pro Logic IIX (or Dolby Pro Logic II) processing for music sources. The Pro Logic IIX decoder is not available when "Surround Back" is set to "None" (see page 106).				
Panorama	Dimension	Center Width		



SUR.DECODE 6	SUR. DECODE	PLIIx Game PL II Game		
Dolby Pro Logic IIx (or Dolby Pro Logic II) processing for game sources. The Pro Logic IIx decoder is not available when "Surround Back" is set to "None" (see page 106).				
SUR.DECODE 6	SUR. DECODE	Neo:6 Cinema		
DTS processing for movie sources.				
SUR.DECODE 6	SUR. DECODE	Neo:6 Music		
DTS processing for music sources.				
<b>Center Image</b>				
SUR.DECODE 6	SUR. DECODE	neural sur. (U.S.A. and Canada models only)		
Neural Surround processing for any sources. The Neural Surround decoder is compatible with PCM signals (32 kHz, 44.1 kHz, 48 kHz, 64 kHz, 88.2 kHz and 96 kHz) and analog 2-channel input sources. When Neural Surround-incompatible signals are being input while the Neural Surround decoder is selected, multi-channel sources are decoded straight into the appropriate channels without any additional effect processing and the Neural Surround-incompatible PCM signals are played back in stereo. The Neural Surround decoder is especially suitable for the XM HD Surround program of XM Satellite Radio.				

 When you select the surround decode mode for Dolby Digital, DTS or DTS 96/24 sources, this unit automatically selects "SURROUND DECODE Dolby Digital", "SURROUND DECODE DTS" or "SURROUND DECODE DTS 96/24" program.

**■ Selecting decoders used with sound field programs**

Use this feature to select the desired decoder used with MOVIE sound field programs (except "Mono Movie"). See page 49 for details about MOVIE sound field program.

**Available decoders (Decoder Type)**

Decoder	Functions
PRO LOGIC	Dolby Pro Logic processing for any sources
PLIIx Movie PLII Movie	Dolby Pro Logic IIx (or Dolby Pro Logic II) processing for movie sources. The Pro Logic IIx decoder is not available when "Surround Back" is set to "None" (see page 106).
Neo:6 Cinema	DTS processing for movie sources

- 1 Set the operation mode selector to AMP and then press MOVIE on the remote control repeatedly to select the desired MOVIE sound field programs.**

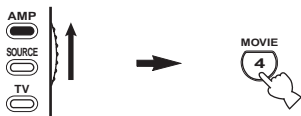

- 2 Press SELECT repeatedly to select the desired decoder used with the selected sound field program.**

You can select from the following decoders depending on the type of source you are playing and your personal preference.

- 
- You can select the desired decoder by pressing SELECT and then press </> repeatedly on the remote control.
  - You can also select decoders used with sound field programs by using GUI screen. Set "Decoder Type" in Stereo/Surround" to the desired setting (see page 88).

**■ Selecting decoders for multi-channel sources**

If you connected surround back speakers, use this feature to enjoy 6.1/7.1-channel playback for multi-channel sources using the Dolby Pro Logic IIX, Dolby Digital EX or DTS-ES decoders.

- 1 Set the operation mode selector to AMP and then press EXT D SUR. on the remote control repeatedly to switch between 5.1 and 6.1/7.1-channel playback.**



- 2 Press ◀/▶ repeatedly to select a decoder while the name of the decoder is displayed.**

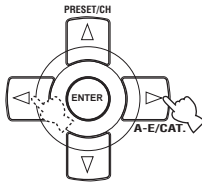

**Auto AUTO**

When a signal flag that can be recognized by this unit is input, this unit selects the optimum decoder to play back the signal in 6.1/7.1 channels. If this unit cannot recognize the flag or no flag is present in the input signal, it cannot automatically be played in 6.1/7.1 channels.

**Decoders**

You can select from the following decoders depending on the format of the source you are playing.

Decoder	Functions
PLIIXMovie D+PLIIX Movie DTS+PLIIX Movie MPCM+PLIIX Movie DSD+PLIIX Movie	Plays back multi-channel sources in 7.1 channels using the Pro Logic IIX movie decoder.
PLIIXMusic D+PLIIX Music DTS+PLIIX Music MPCM+PLIIX Music DSD+PLIIX Music	Plays back multi-channel sources in 6.1/7.1 channels using the Pro Logic IIX music decoder.
DTS ES DTS 96/24 ES	Plays back DTS signals in 6.1/7.1 channels using the DTS-ES decoder.
DOLBY D EX DTS+DOLBY EX MPCM+DOLBY EX DSD+DOLBY EX	Plays back multi-channel sources in 6.1/7.1 channels using the Dolby Digital EX decoder.

**Off OFF**

Decoders are not used to create 6.1/7.1 channels.

**Notes**

- “PLIIX Movie” is available only when “Surround Back” (see page 106) is set to “Small x2” or “Large x2”.
- Some 6.1/7.1-channel compatible discs do not have a signal flag that can be automatically detected by this unit. When playing these kinds of discs in 6.1/7.1 channels, select a decoder manually from “PLIIX Music”, “EX/ES” or “EX”.
- 6.1/7.1-channel playback is not possible even if you press EXT D SUR. in the following cases:
  - when “Surround” (see page 106) or “Surround Back” (see page 106) is set to “None”.
  - when the component connected to the MULTI CH INPUT jacks is being played.
  - when the source being played does not contain surround left and right channel signals.
  - when a Dolby Digital KARAOKE source is being played.
  - when the “2ch Stereo” (see page 53) or Pure Direct (see page 52) mode is selected.
- When this unit is turned off, this setting will be reset to “Auto”.
- The Pro Logic IIX decoder is not available when “Surround Back” is set to “None” (see page 106).

# GRAPHIC USER INTERFACE (GUI) SCREEN

This unit features a sophisticated graphical user interface (GUI) screen that helps you to control the amplifier function of this unit. With the GUI screen, you can view the information of the signals being input and the status of this unit.

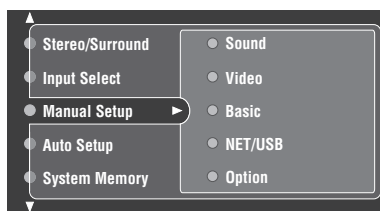

## ■ Stereo/Surround (Stereo/Surround menu)

Use this feature to select the sound field programs and customize the program parameter settings (see page 88).

## ■ Input Select (Input select menu)

Use this feature to select the input source and customize the parameters of each input source.

## ■ Manual Setup (Manual setup menu)

Use this feature to manually adjust speaker and system parameters (see page 97).

### Sound (Sound menu)

Use this menu to manually adjust any speaker settings, alter the quality and tone of the sound output by the system or compensate for video signal processing delays when using LCD monitors or projectors (see page 97).

### Video (Video menu)

Use this feature to manually adjust the video parameters (see page 101).

### Basic (Basic menu)

Use this feature to manually adjust the basic speaker parameters (see page 104).

### NET/USB (Network and USB menu)

Use this menu to manually adjust the network and USB system parameters (see page 109).

### Option (Option menu)

Use this feature to manually adjust the optional system parameters (see page 111).

## ■ Auto Setup (Auto setup menu)

Use this menu to run Auto Setup and specify which speaker parameters to be adjusted (see page 35).

## ■ System Memory (System memory menu)

Use this feature to store and recall various settings of this unit (see page 115).

## ■ Signal Info. (Signal information)

Use this feature to check audio signal information (see page 116).

## ■ Language (GUI language menu)

Use this feature to select the language of your choice that appears in the GUI screen of this unit (see page 117).



- You can also select the GUI language using “GUI LANGUAGE” parameter in “ADVANCED SETUP” in the front panel display (see page 136).
- See page 44 for details about the operations in GUI screen.

## Stereo/Surround (Stereo/Surround menu)

Use this feature to select the sound field programs (see page 46), the surround decode mode, the “STRAIGHT” mode (See page 51) or the Compressed Music Enhancer mode (See page 54), and adjust the parameters of each program.

### ■ Selecting sound field programs and setting the parameters by using GUI screen

- 1 Set the operation mode selector to AMP and then press SET MENU on the remote control.



- 2 Press  $\Delta / \nabla / \triangleleft / \triangleright$  on the remote control to select “Stereo/Surround” and then press  $\triangleright$ .

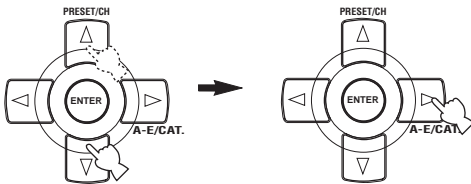

- 3 Press  $\Delta / \nabla$  repeatedly to select the desired category of the programs and then press  $\triangleright$ .

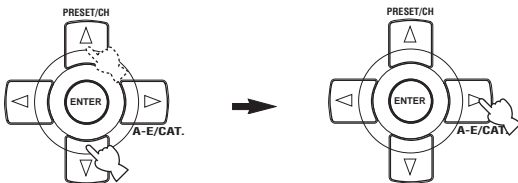

- 4 Press  $\Delta / \nabla$  repeatedly to select the desired programs.

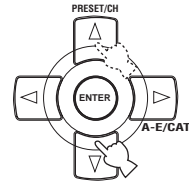

- 5 Press  $\triangleright$  on the remote control and then  $\Delta / \nabla$  to select the desired parameter.

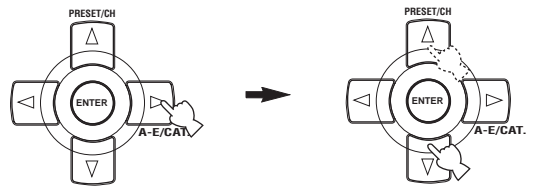

You can select “Initialize” to set all the parameters of the selected sound field program to the default values. See page 93 for details.

- 6 Press  $\triangleright$  and then press  $\triangleleft / \triangleright$  to adjust the selected parameter.

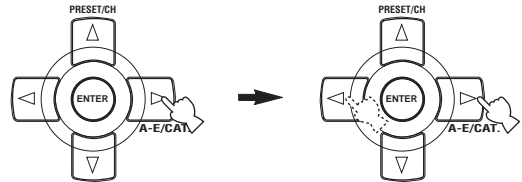

- 7 Press ENTER or  $\Delta / \nabla$  to confirm the setting of the selected parameter.

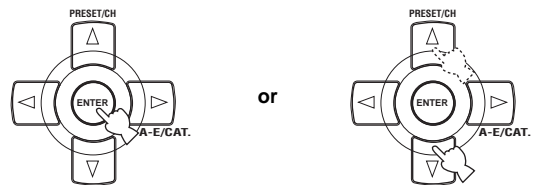

### ■ Sound field parameter descriptions

You can adjust the values of certain digital sound field parameters so that the sound fields are recreated accurately in your listening room. Not all of the following parameters are found in every program.

Sound field parameter	Features
<b>Decoder Type</b>	Decoder type. Selects the decoder used with the SUR. DECODE or MOVIE programs. See pages 84 and 85 for details.
<b>DSP Level</b>	DSP level. Adjusts the level of all the DSP effect sounds within a narrow range. Depending on the acoustics of your listening room, you may want to increase or decrease the DSP effect level relative to the level of the direct sound.  Control range: -6 dB to +3 dB
<b>Init. Delay</b> <b>Sur. Init. Delay</b> <b>SB Init. Delay</b>	Initial delay. Presence, surround, and surround back initial delay. Changes the apparent distance from the source sound by adjusting the delay between the direct sound and the first reflection heard by the listener. The smaller the value, the closer the sound source seems to the listener. The larger the value, the farther it seems. For a small room, set to a small value. For a large room, set to a large value.  Control range: 1 to 99 ms (Init. Delay) 1 to 49 ms (Sur. Init. Delay and SB Init. Delay)

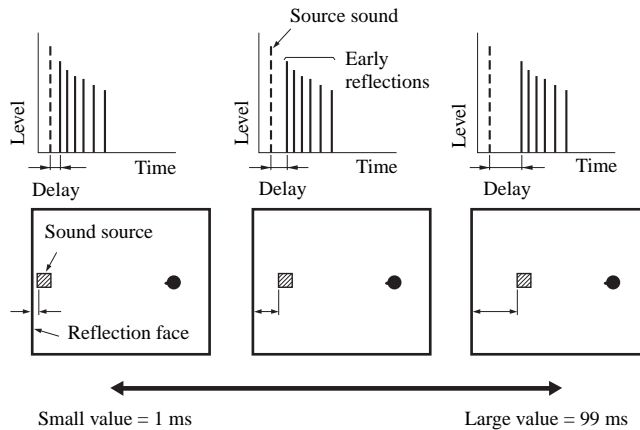

Sound field parameter	Features
-----------------------	----------

**Room Size**  
**Sur. Room Size**  
**SB Room Size**

Room size. Presence, surround, and surround back room size. Adjusts the apparent size of the surround sound field. The larger the value, the larger the surround sound field becomes. As the sound is repeatedly reflected around a room, the larger the hall is, the longer the time between the original reflected sound and the subsequent reflections. By controlling the time between the reflected sounds, you can change the apparent size of the virtual venue. Changing this parameter from one to two doubles the apparent length of the room.

Control range: 0.1 to 2.0

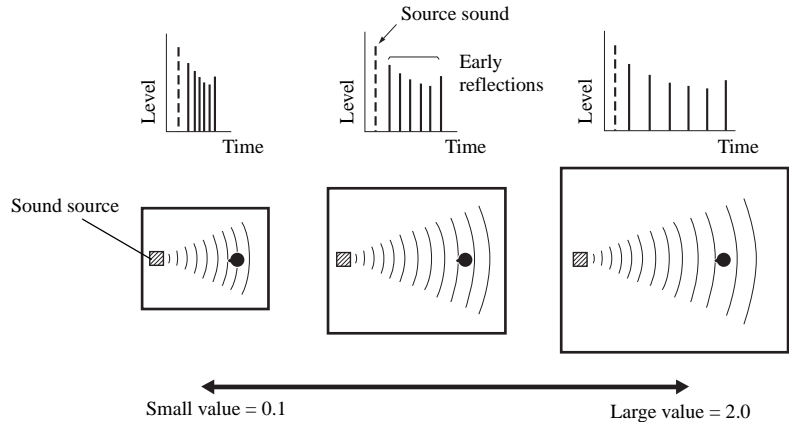

**Liveness**  
**Sur. Liveness**  
**SB Liveness**

Liveness. Surround and surround back liveness. Adjusts the reflectivity of the virtual walls in the hall by changing the rate at which the early reflections decay. The early reflections of a sound source decay much faster in a room with acoustically absorbent wall surfaces than in one which has highly reflective surfaces. A room with acoustically absorbent surfaces is referred to as “dead”, while a room with highly reflective surfaces is referred to as “live”. This parameter lets you adjust the early reflection decay rate and thus the “liveness” of the room.

Control range: 0 to 10

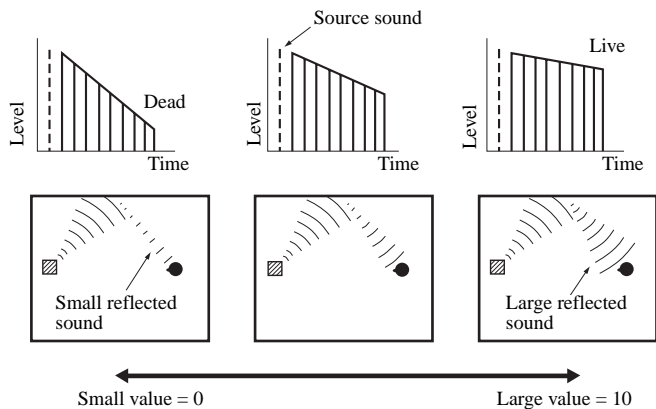

Sound field parameter	Features
-----------------------	----------

**Rev. Time**

Reverberation time. Adjusts the amount of time taken for the dense, subsequent reverberation sound to decay by 60 dB at 1 kHz. This changes the apparent size of the acoustic environment over an extremely wide range. Set a longer reverberation time for “dead” sources and listening room environments, and a shorter time for “live” sources and listening room environments.

Control range: 1.0 to 5.0 s

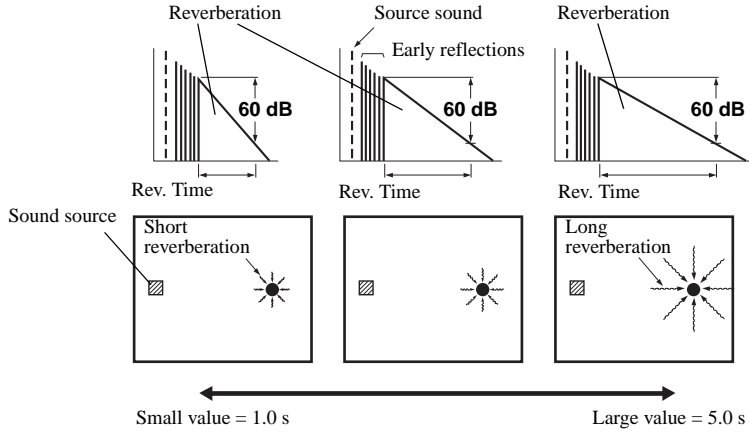

**Rev. Delay**

Reverberation delay. Adjusts the time difference between the beginning of the direct sound and the beginning of the reverberation sound. The larger the value, the later the reverberation sound begins. A later reverberation sound makes you feel as if you are in a larger acoustic environment.

Control range: 0 to 250 ms

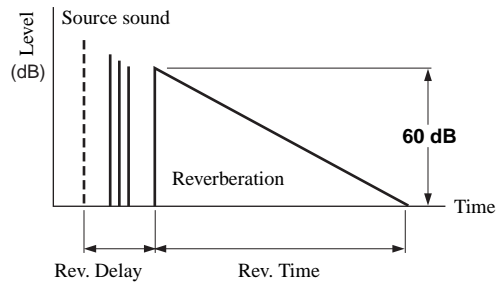

Sound field parameter	Features
<b>Rev. Level</b>	Reverberation level. Adjusts the volume of the reverberation sound. The larger the value, the stronger the reverberation becomes.
	Control range: 0 to 100%

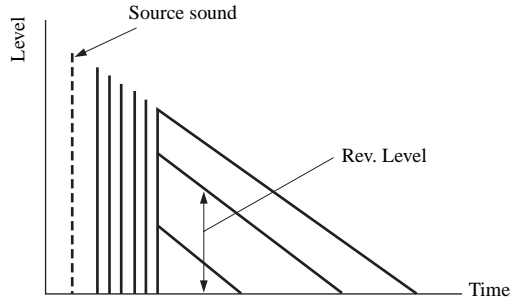

<b>Dialogue Lift</b>	Dialogue lift. Adjusts the height of the front and center channel sounds by assigning some of the front and center channel elements to the presence speakers. The larger the parameter, the higher the position of the front and center channel sound.
	Choices: 0, 1, 2, 3, 4, 5

■ Stereo program parameter descriptions

Sound field parameter	Features
<b>2ch Stereo Direct</b>	2-channel stereo direct. Bypasses the decoders and DSP processors of this unit for pure hi-fi stereo sound when playing 2-channel analog sources.
	Choices: Auto, Off
	 <ul style="list-style-type: none"> <li>• Select “Auto” to bypass the decoders, DSP processors and the tone control circuitry only when “BASS” and “TREBLE” are set to 0 dB (see page 52).</li> <li>• Select “Off” not to bypass the decoders, DSP processors and the tone control circuitry when “BASS” and “TREBLE” are set to 0 dB.</li> <li>• When multi-channel signals (Dolby Digital and DTS) are input, they are downmixed to 2 channels and output from the front left and right speakers.</li> <li>• The low-frequency signals input from the front left and right speakers are redirected to the subwoofer in the following cases:                             <ul style="list-style-type: none"> <li>– “Bass Out” is set to “Both” (see page 107).</li> <li>– “Front” is set to “Small” (see page 105) and “Bass Out” is set to “SWFR” (see page 107).</li> </ul> </li> </ul>
<b>7ch Stereo</b>	7-channel stereo center, surround left, surround right, surround back, presence left and presence right levels. Adjusts the volume level of each channel in the 7-channel stereo mode.
<b>Center Level</b> <b>Surround L Level</b> <b>Surround R Level</b> <b>Sur. Back Level</b> <b>Presence L Level</b> <b>Presence R Level</b>	Control range: 0 to 100%



■ The Compressed Music Enhancer mode parameter descriptions

The Compressed Music Enhancer mode	Features
2ch Enhancer 7ch Enhancer	2-channel enhancer or 7-channel enhancer effect level. Select “High” or “Low” to adjust the effect for the high-frequency.  Choices: <b>High</b> , Low

■ Decoder parameter descriptions

Decoder parameter	Features
Pro Logic IIx Music PRO LOGIC II Music Panorama	Pro Logic IIx Music and Pro Logic II Music panorama. Sends stereo signals to the surround speakers as well as the front speakers for a wraparound effect.  Choices: <b>Off</b> , On
PRO LOGIC IIx Music PRO LOGIC II Music Dimension	Pro Logic IIx Music and Pro Logic II Music dimension. Adjusts the sound field either towards the front or towards the rear.  Control range: -3 (towards the rear) to +3 (towards the front)  Initial setting: STD (standard)
PRO LOGIC IIx Music PRO LOGIC II Music Center Width	Pro Logic IIx Music and Pro Logic II Music center width. Moves the center channel output completely towards the center speaker or towards the front left and right speakers. A larger value moves the center channel output towards the front left and right speakers.  Control range: 0 (center channel sound is output only from the center speaker) to 7 (center channel sound is output only from the front left and right speakers)  Initial setting: 3
DTS Neo:6 Music Center Image	DTS Neo:6 Music center image. Adjusts the front left and right channel output relative to the center channel to make the center channel more or less dominant as necessary.  Control range: 0.0 to 1.0  Initial setting: 0.3

■ Initialize (Program parameters initialization)

Use this feature to initialize the parameter of the selected sound field program.

Choices: **No**, Yes

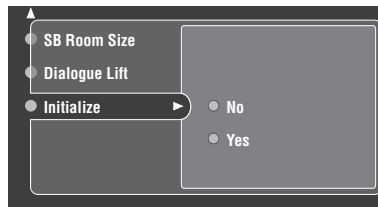

- Select “Yes” to set the program parameters to the factory default settings.
- Select “No” to cancel the program parameter initialization.

 Use the “Sur. Initialize” feature in “Option” to initialize the parameters of each sound field program within a sound field program group (see page 114).

## Input Select

Use this feature to reassign digital input/outputs, select the input signal, rename the inputs, or adjust the level of the signal input at each input source.

Input source	Parameter
XM (U.S.A. and Canada models only)	Antenna Level Volume Trim Rename
TUNER	Volume Trim Rename
PHONO CD CD-R MD/TAPE DVD DTV CBL/SAT VCR1 DVR/VCR2	I/O Assignment Audio Select Decoder Mode Volume Trim Rename
V-AUX or DOCK	I/O Assignment* Audio Select* Decoder Mode* Volume Trim Rename
PC/MCX, NET RADIO or USB	Volume Trim
MULTI CH	I/O Assignment Audio Select Decoder Mode Volume Trim Rename Multi CH Assign BGV

### Notes

- Some parameters described above may not be available for all input sources and some parameters are only available for specific input sources.
- When iPod is stationed in a YAMAHA iPod universal dock (such as YDS-10, sold separately) connected to the DOCK terminal of this unit, “DOCK” appears in the “Input Select” menu instead of “V-AUX”. In such cases, the parameters marked with asterisk (\*) in the above table does not appears in the input source parameter menu.
- When you select “NET/USB” as the input source, selected sub input source (PC/MCX, NET RADIO or USB) appears in the Input Select menu.

- 1 Set the operation mode selector to AMP and then press SET MENU on the remote control.

The top display appears.

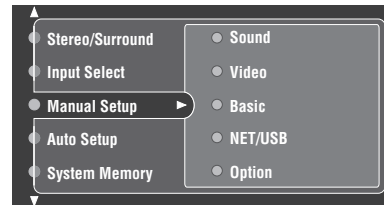

- 2 Select “Input Select” and then press  $\triangleright$ .

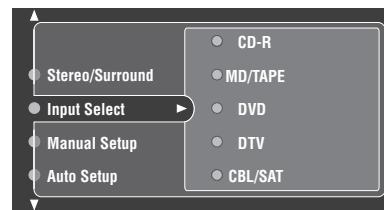

- 3 Select the desired input source (CD, DVD, etc.) and then press  $\triangleright$  or ENTER to access and adjust.

### ■ Antenna Level (Antenna level)

Use this feature to check the current reception level of the XM Passport System connected to the XM jack of this unit (see page 63). For the best reception, orient the XM Passport System so that a value of 60% or more is displayed here.

Display status: None, 0 to 100%

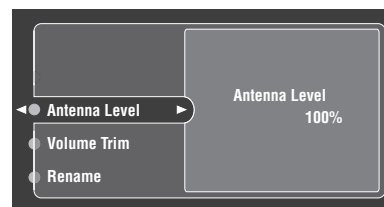

### Notes

- “None” is displayed if the XM Passport System is not connected to this unit. In this case, check the antenna connections (see page 63).
- The “Antenna Level” parameter cannot be adjusted by using the remote control. Instead, you need to adjust the orientation of the XM Passport System connected to the XM jack of this unit for a better percentage of the reception level.

### ■ Volume Trim (Volume trimming)

Use this feature to adjust the level of the signal input at each input source. This is useful if you want to balance the level of each input source to avoid sudden changes in volume when switching between input sources.

Control range: -6.0 dB to +6.0 dB

Initial setting: 0.0 dB

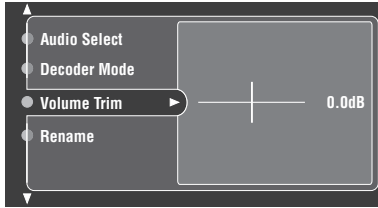

This parameter also affects the signals output at ZONE OUT jacks.

#### Note

- You can only adjust the volume for the current input source using this setting.

### ■ Rename (Rename)

Use this feature to change the name of the inputs in the GUI screen or the front panel display menu. (DVD is used as the source component in the following example.)

- 1 Press  $\triangleleft$  /  $\triangleright$  to place the \_ (under-bar) under the space or character you want to edit.

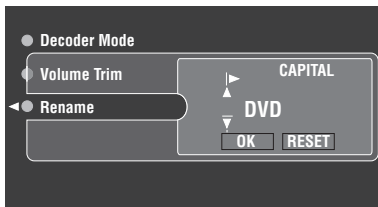

- 2 Press ENTER repeatedly to select a character type (CAPITAL/SMALL/FIGURE/MARK).

- 3 Press  $\triangle$  /  $\nabla$  to select the character you want to use and  $\triangleleft$  /  $\triangleright$  to move to the next one.

- You can use up to 8 characters for each input.
- Press  $\nabla$  to change the character in the following order, or press  $\triangle$  to go in the reverse order:  
 CAPITAL A to Z, space  
 SMALL a to z, space  
 FIGURE 0 to 9, space  
 MARK !, #, %, &, etc.
- Press ENTER to switch between character types.
- Repeat steps 1 to 3 to rename each input.

#### Note

Even if you select “Français”, “Deutsch”, Español” or “Русский” in “Language” (see page 117), you cannot use accent symbols or cyrillic alphabets for the name of each input.

- 4 Press  $\triangleleft$  /  $\triangleright$  to select OK and press ENTER when complete.



- Select “RESET” to set the name of the selected input to default.
- This feature is useful when you change the input or output assignment for digital jacks and component video input jacks.
- You can also change the name of the input source that appears in the display window on the remote control. Refer to “Changing source names in the display window” on page 123”.

#### Note

You can only change the name of the current input source (except for multi channel input sources) using this setting.

### ■ I/O Assignment (Input/output assignment)

Use this feature to assign the input/output jacks according to the component to be used if the initial settings of this unit do not correspond to your needs. Change the following parameters to reassign the respective jacks and effectively connect more components.

Once the input/output jacks are reassigned, you can select the corresponding component by using the INPUT selector on the front panel (or the input selector buttons on the remote control).

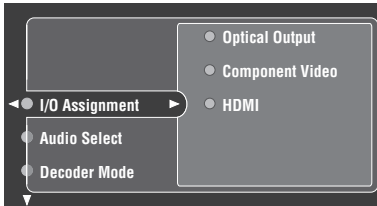

**Example 1: Assigning the COAXIAL ① CD jack to the DVD input.**

- 1 Select "Input Select" in the GUI screen and then select "DVD".
- 2 Select "I/O Assignment" and then "Coaxial Input".
- 3 Select "① CD".

**Example 2: Clearing a jack assignment.**

- 1 Select "Input Select" and then select the desired input source ("DVD", etc.).
- 2 Select "I/O Assignment" and then select the desired jack assignment ("Coaxial Input", "Optical Input", "Optical Output", "Component Video", or "HDMI").
- 3 Select "None" and then press ENTER to clear the assignment.

**Notes**

- You cannot select a specific item more than once for the same type of jack.
- When you connect a component to both the COAXIAL and OPTICAL jacks, priority is given to signals input at the COAXIAL jack.

### ■ Audio Select (Audio input jack select)

This unit comes with a variety of input jacks. You can select the type of input signal you want to use.

Choices: **Auto**, HDMI, Coax/Opt, Analog

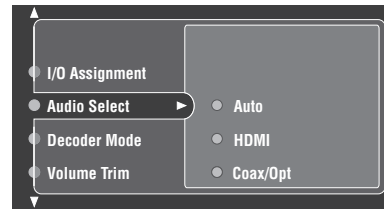

- Select "Auto" when you want signals to be input to this unit in the following order: HDMI signals, digital signals and analog signals.
- Select "HDMI" when you only want HDMI signals to be input to this unit. If no HDMI signals are input, no sound is output.
- Select "Coax/Opt" when you want digital signals to be input to this unit at the OPTICAL or COAXIAL jacks. Use if HDMI signals are also being input.
- Select "Analog" when you only want analog signals to be input to this unit. If no analog signals are input, no sound is output.



- You can also select the audio input jack by pressing AUDIO SELECT on the front panel (or AUDIO SEL on the remote control). See page 42 for details.
- You can set the default Audio input jack select of this unit by using "Audio Select" in "Option" (see page 114).

**Note**

This feature is not available when no digital input jack (OPTICAL, COAXIAL and HDMI) are assigned. In addition, "HDMI" is not available as an Audio input jack select setting when the HDMI IN 1, HDMI IN 2 and HDMI IN 3 jacks are not used. Use "I/O Assignment" in "Input Select" to reassign the respective input jack (see page 96).

### ■ Decoder Mode (Decoder mode)

Use this feature to switch the input mode. You can designate the reassigned digital input jacks (see page 96) for specific audio signals (DTS, etc.).

Choices: **Auto**, DTS

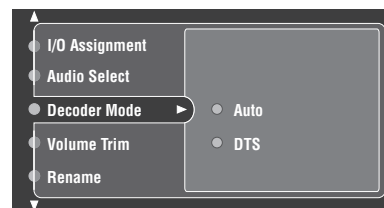

- Select "Auto" if you want this unit to automatically detect input signal types and select the appropriate input mode.
- Select "DTS" if you want this unit to select DTS as the input mode.

## Multi CH Assign (Multi channel assignment)

Use this feature to set the direction of the signals input into the center, subwoofer and surround channels when a source component is connected to the MULTI CH INPUT jacks. If you input 8-channel signals from an external decoder, use this feature to select jacks for the additional front signals.

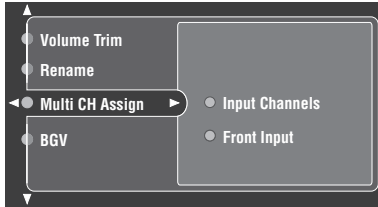

### Input Channels (Input channels)

This setting is used to select the number of channels input from an external decoder.

Choices: **6ch**, 8ch

#### Note

If "Zone2 Amplifier" (page 113) is set to "INT:[SP1]", "INT:[SP2]" or "INT:Both", no sound is output from the surround back speakers even if you select "8ch". In this case, select "6ch" and set the output setting of the external component to 6 channels.

### Front Input (Front input)

If you selected "8ch" in Input Channels, you can select analog jacks at which front signals from an external decoder will be input.

Choices: **DVD**, DTV, CBL/SAT, VCR1, DVR/VCR2, V-AUX, CD, CD-R, MD/TAPE

## BGV (Back ground video)

Use this feature to select the video source played in the background of the sources input from the MULTI CH INPUT jacks.

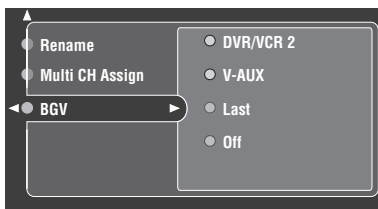

Choices: DVD, DTV, CBL/SAT, VCR 1, DVR/VCR 2, V-AUX, **Last**, Off

- Select "Last" to set this unit to automatically select the last selected video source as the background video source.
- Select "Off" to set this unit not to play the video source in the background.

## Manual Setup (Sound)

Use this menu to adjust the sound parameters.

- 1 Set the operation mode selector to AMP and then press SET MENU on the remote control.



- 2 Press  $\Delta$  /  $\nabla$  on the remote control to select "Manual Setup" and then press  $\triangleright$ .

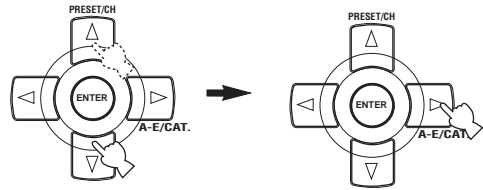

- 3 Press  $\Delta$  /  $\nabla$  /  $\triangleleft$  /  $\triangleright$  on the remote control to select "Sound" and then press  $\triangleright$ .

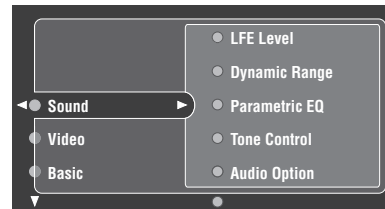
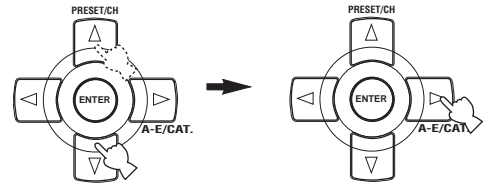

- 4 Select the desired parameters and then press  $\triangleright$  to access and adjust.

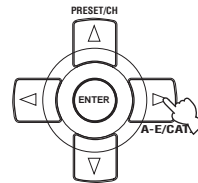

■ **LFE Level (Low-frequency effect level)**

Use this feature to adjust the output level of the LFE (low-frequency effect) channel according to the capacity of your subwoofer or headphones. The LFE channel carries low-frequency special effects which are only added to certain scenes. This setting is effective only when this unit decodes Dolby Digital or DTS signals.

Control range: -20.0 to **0.0** dB

Control step: 1.0 dB

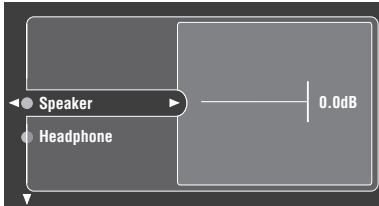

**Speaker (Speaker low-frequency effect level)**

Select to adjust the speaker LFE level.

**Headphone (Headphone low-frequency effect level)**

Select to adjust the headphone LFE level.

**Note**

Depending on the settings of “LFE Level”, some signals may not be output at the SUBWOOFER jack.

■ **Dynamic Range (Dynamic range)**

Use this feature to select the amount of dynamic range compression to be applied to your speakers or headphones. This setting is effective only when the unit is decoding Dolby Digital and DTS signals.

Choices: **MAX** (maximum), **STD** (standard), **MIN** (minimum)

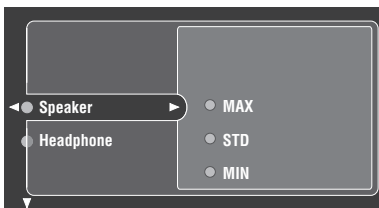

**Speaker (Speaker dynamic range)**

Select to adjust the speaker compression.

**Headphone (Headphone dynamic range)**

Select to adjust the headphone compression.

- Select “MAX” to preserve the greatest amount of dynamic range.
- Select “STD” for general use.
- Select “MIN” for listening to sources at low volume levels.

■ **Parametric EQ (Parametric equalizer)**

Use this feature to adjust the parametric equalizer of each speaker.

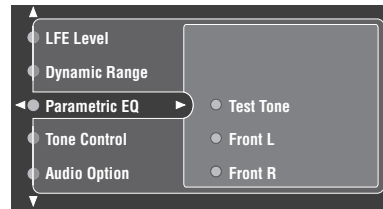

**1 Press  $\Delta$  /  $\nabla$  /  $\leftarrow$  /  $\rightarrow$  to select Test Tone or the speaker you want to adjust.**

- Select “Test Tone” to choose whether turns on or off the test tone output when adjusting the tonal quality of each speaker.
- Select “Front L” to adjust the tonal quality of the front left speaker.
- Select “Front R” to adjust the tonal quality of the front right speaker.
- Select “Center” to adjust the tonal quality of the center speaker.
- Select “Surround L” to adjust the tonal quality of the surround left speaker.
- Select “Surround R” to adjust the tonal quality of the surround right speaker.
- Select “Surround Back L” to adjust the tonal quality of the surround back left speaker.
- Select “Surround Back R” to adjust the tonal quality of the surround back right speaker.
- Select “Presence L” to adjust the tonal quality of the presence left speaker.
- Select “Presence R” to adjust the tonal quality of the presence right speaker.
- Select “Subwoofer” to adjust the tonal quality of the subwoofer.

**2 Press  $\triangleright$  to access the settings window.**

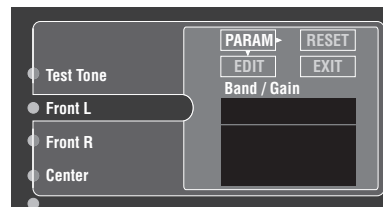

**3 Press  $\Delta$  /  $\nabla$  /  $\leftarrow$  /  $\rightarrow$  to select “PARAM” and then press ENTER to select a parameter from “Band” (band), “Freq.” (frequency) or “Q” (Q factor).**



You can adjust the gain with any parameter.

**4** Press  $\nabla$  to select “EDIT” and press ENTER to access the edit window.

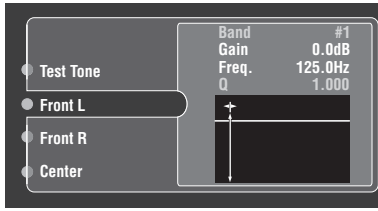

The parameter selected in “PARAM” is highlighted.

- Press  $\triangleleft / \triangleright$  to adjust the parameter.
- Press  $\triangleup / \nabla$  to adjust the “Gain”.
- Press ENTER to exit the edit window.



- When you select “Band” in step 3, you can use this menu as a graphic equalizer.
- The “Band #1” and “Band #2” can adjust the frequencies below of 198.4 Hz.
- When you select “Subwoofer” in step 1 and “Band” in step 3, you can adjust “Band #1” and “Band #2” only.
- For more information on the parametric equalizer, see page 98.

**5** Repeat steps 3 and 4 until you are satisfied with the results.



If you want to reset all “Parametric EQ” parameter settings for the selected speaker, select “RESET” and press ENTER.

**6** Select “EXIT” and press ENTER to exit the settings window.

**■ Tone Control (Tone control)**

Use this feature to adjust the balance of bass and treble output to your speakers or headphones.

Choices: Control, Bass, Treble, Audio Bypass

**Note**

Tone Control is not effective when:

- PURE DIRECT (see page 52) is selected.
- MULTI CH INPUT is selected as the input source.

**Control (Tone control)**

Choices: **Speakers**, Headphones



- Select “Speakers” to adjust the bass/treble balance of your speakers.
- Select “Headphones” to adjust the bass/treble balance of your headphones.



“Speaker” and “Headphone” adjustments are stored independently. The adjustments for “Speaker” affects the front left/right, center, presence left/right speaker channels and Subwoofer channel.

**Bass (Bass control)**

Use this feature to adjust low-frequencies output to your speakers or headphones.

Choices: 125Hz, **350Hz**, 500Hz

Control range: –6.0 dB to +6.0 dB

Initial setting: 0.0 dB

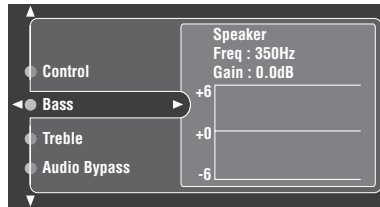

**Treble (Treble control)**

Use this feature to adjust high-frequencies output to your speakers or headphones.

Choices: 2.5kHz, **3.5kHz**, 8.0kHz

Control range: –6.0 dB to +6.0 dB

Initial setting: 0.0 dB

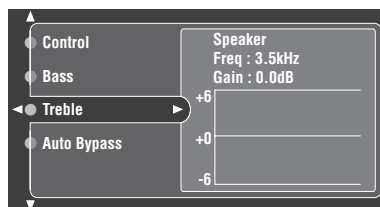

### Auto Bypass (Auto bypass)

Use this feature to select whether the audio output bypasses the tone control circuitry when “TREBLE” and “BASS” are set to 0 dB (see page 52).

Choices: **Auto**, Off

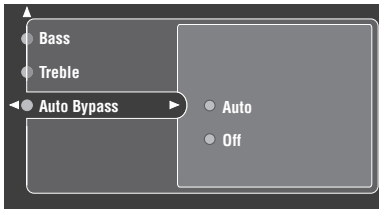

- Select “AUTO” if you want the signals to bypass the tone control circuitry to provide the purest signal possible.
- Select “OFF” if you do not want the signals to bypass the tone control circuitry.

### Audio Option (Audio options)

Use this feature to adjust the overall audio settings of this unit.

#### Muting Type (Muting type)

Use this feature to adjust how much the mute function reduces the output volume.

Choices: **Full**, -20dB



- Select “Full” to completely mute all the audio output.
- Select “-20dB” to reduce the current volume by 20 dB.

### Audio Delay (Audio delay)

Use this feature to delay the sound output and synchronize it with the video image. This may be necessary when using certain LCD monitors, projectors or high definition monitors.

Control range: **0** to 240 ms

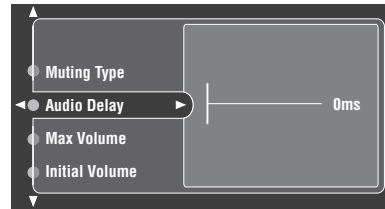

### Max Volume (Maximum volume)

Use this feature to set the maximum volume level in the main zone. This feature is useful to avoid the unexpected loud sound by mistake. For example, the original volume range is 16.5 dB to -80.0 dB. However, when “Max Volume” is set to -5.0 dB, the volume range becomes -5.0 dB to -80.0 dB.

Control range: **16.5 dB**, 15.0 dB to -30.0 dB

Control step: 5.0 dB

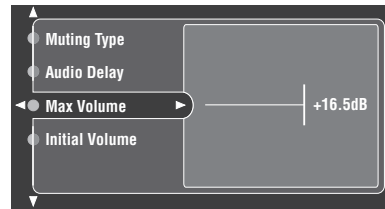

### Notes

- When a test tone is output, the “Max Volume” setting is automatically deactivated because the volume level is automatically set to 0 dB regardless of the current “Max Volume” setting.
- The “Max Volume” setting takes priority over the “Initial Volume” setting (see page 100). For example, “Initial Volume” is set to -20.0 dB and then “Max Volume” is set to -30.0 dB, the volume level is automatically set to -30.0 dB when you turn on the power of this unit next time.

### Initial Volume (Initial volume)

Use this feature to set the volume level of the main zone when the power of this unit is turned on.

Choices: **Off**, -80 dB to +16.5 dB

Control step: 0.5 dB

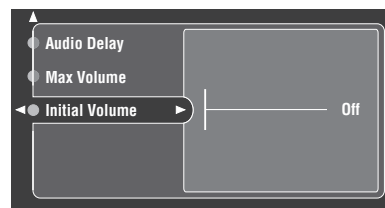



**Note**

The “Max Volume” setting takes priority over the “Initial Volume” setting. Therefore, Initial Volume cannot be set beyond the existing “Max Volume” setting.

**Channel Mute (Channel mute)**

Use this feature to mute specific speaker channels.

**Mode (Mode)**

Use this feature to activate or deactivate the “Channel Mute” setting for each speaker.

Choices: **Off, On**

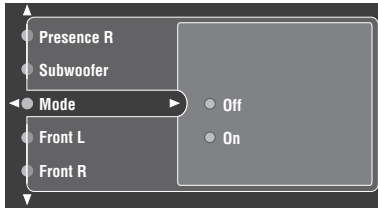

- Select “Off” to deactivate the “Channel Mute” settings.
- Select “On” to activate the “Channel Mute” settings.

**Each speaker settings**

Choices: **Mute, Off**

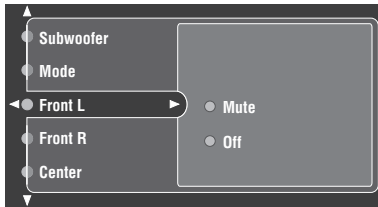

- Select “Mute” to mute the selected speaker channel.
- Select “Off” not to mute the selected speaker channel.
- “Front L” sets whether to mute the audio output from the front left speaker.
- “Front R” sets whether to mute the audio output from the front right speaker.
- “Center” sets whether to mute the audio output from the center speaker.
- “Surround L” sets whether to mute the audio output from the surround left speaker.
- “Surround R” sets whether to mute the audio output from the surround right speaker.
- “Surround Back L” sets whether to mute the audio output from the surround back left speaker.
- “Surround Back R” sets whether to mute the audio output from the surround back right speaker.
- “Presence L” sets whether to mute the audio output from the presence left speaker.
- “Presence R” sets whether to mute the audio output from the presence right speaker.
- “Subwoofer” sets whether to mute the audio output from the subwoofer.

**Manual Setup (Video)**

Use this menu to adjust the video parameters.

- 1 Set the operation mode selector to AMP and then press SET MENU on the remote control.**



- 2 Press  $\Delta$  /  $\nabla$  on the remote control to select “Manual Setup” and then press  $\triangleright$ .**

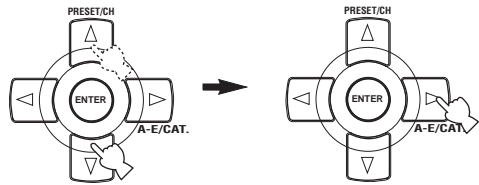

- 3 Press  $\Delta$  /  $\nabla$  /  $\triangleleft$  /  $\triangleright$  on the remote control to select “Video” and then press  $\triangleright$ .**

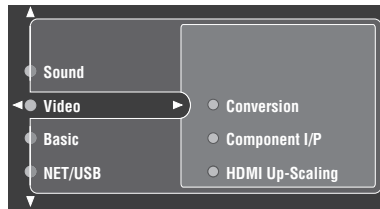
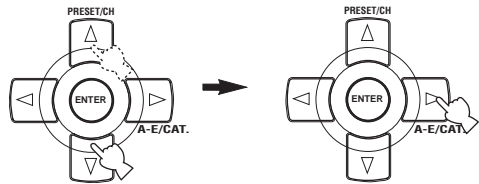

- 4 Select the desired parameters and then press  $\triangleright$  to access and adjust.**

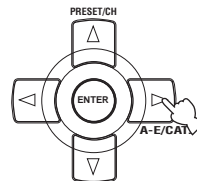

**Note**

Use the “V-RESET” in “ADVANCED SETUP” to set the parameters in “Manual Setup (Video)” (except “Short Message” and “On Screen”) to the factory presets (see page 136).

■ **Conversion (Video conversion)**

Use this feature to activate or deactivate the video conversion as well as the HDMI up-conversion of the analog video signals input at the composite video, S-video and component video jacks.

Choices: Off, **On**

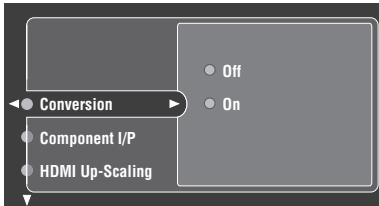

- Select “Off” to deactivate the video conversion as well as the HDMI up-conversion of the analog video signals.
- Select “On” to activate the video conversion as well as the HDMI up-conversion of the analog video signals.

**Notes**

- This unit does not convert 480 line video signals and 576 line video signals interchangeably.
- The analog component video signals with 480i (NTSC)/576i (PAL) of resolution are converted to the s-video or composite video signals and output at the S VIDEO MONITOR OUT and VIDEO MONITOR OUT jacks.
- The converted video signals are only output at the MONITOR OUT jacks. When recording a video source, you must make the same type of video connections between each component.
- When composite video or S-video signals from a VCR are converted to component video signals, the picture quality may suffer depending on your VCR.
- Even when “Conversion” is set to “On”, HDMI digital signals are not converted to analog video signals.
- If “Conversion” is set to “Off”, the “Component I/P” and “HDMI Up-Scaling” features are deactivated.
- Set “Conversion” to “On” to display the short message display.
- Unconventional signals input at the composite video or S-video jacks cannot be converted or may be output abnormally. In such cases, set “Conversion” to “Off”.
- When non-standard video signals (such as video signals from a game console) are input, this unit may not convert the signals even if you “Conversion” to “On”.

■ **Component I/P (Component interlace/progressive conversion)**

Use this feature to activate or deactivate the analog interlace/progressive conversion of the analog video signals input at the composite video, S-video and component video jacks so that the analog video signals deinterlaced from 480i (NTSC)/576i (PAL) to 480p/576p are output at the COMPONENT MONITOR OUT jacks.

Choices: **Off**, On

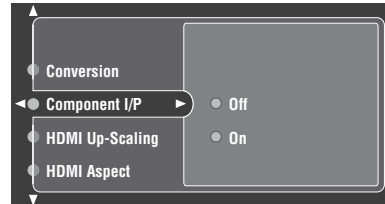

- Select “On” to activate the analog interlace/progressive up-conversion of the analog video signals.
- Select “Off” to deactivate the analog interlace/progressive up-conversion of the analog video signals.

**Notes**

- This menu item is not available and hence not visible in the GUI screen if “Conversion” is set to “Off”.
- If your video monitor does not support analog video signals with 480p/576p of resolution, the GUI screen may not be displayed on your video monitor when “Component I/P” is set to “On”. Use “V-RESET” in “ADVANCED SETUP” to set the “Component I/P” parameter to the factory preset setting (see page 136).

■ **HDMI Up-Scaling (HDMI up-scaling)**

Use this feature to activate or deactivate the HDMI up-conversion of the analog video signals input at the composite video, S-video and component video jacks so that the up-scaled analog video signals are output at the HDMI OUT jack.

This unit up-scales the analog video signals as follows:

- 480i (NTSC)/576i (PAL) → 480p/576p, 1080i or 720p
- 480p/576p → 1080i or 720p

Choices: Through, **480p** (or **576p**), 1080i, 720p

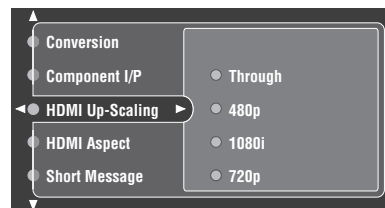

- Select “Through” not to up-scale any analog video signals.
- Select “480p” (or “576p”), “1080i” or “720p” to up-scale analog video signals to 480p or 576p, 1080i or 720p of resolution.

**Notes**

- This menu item is not available and hence not visible in the GUI menu if “Conversion” is set to “Off” (see page 102).
- When you set “TV FORMAT” in “ADVANCED SETUP” to “NTSC” (see page 136), “480p” appears in the choices of “HDMI Up-Scaling”, and when you set “TV FORMAT” to “PAL”, “576p” appears in the choices of “HDMI Up-Scaling”.

■ **HDMI Aspect (HDMI aspect ratio)**

Use this feature to select the adjustment of aspect ratio for HDMI video signal sources.

Choices: **Through**, 16:9 Normal, Smart Zoom

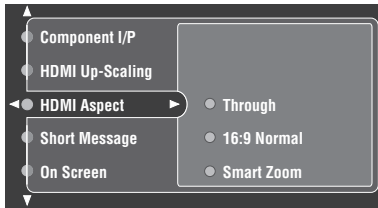

- Select “Through” if you do not make any adjustments to the aspect ratio for HDMI video signal sources.
- Select “16:9 Normal” to display video images with 4:3 of aspect ratio on your video monitor with 16:9 of aspect ratio. Black stripes appear on the right and left sides as a result.
- Select “Smart Zoom” to fit video images with 4:3 of aspect ratio to your video monitor with 16:9 of aspect ratio.

**Notes**

- When “HDMI Up-Scaling” is set to “Through”, you cannot make any adjustments to “HDMI Aspect”.
- When “HDMI Aspect” is set to “Smart Zoom”, the video images of the edge of the video monitor are rather stretched.
- When the video signals are input at HDMI IN jacks or the signals are input with 720p or 1080i of resolution, the setting of “HDMI Aspect” does not affect the video signals output at the HDMI OUT jack.

■ **Short Message (Short message display)**

Use this feature to activate or deactivate the short message display function.

Choices: Off, **On**

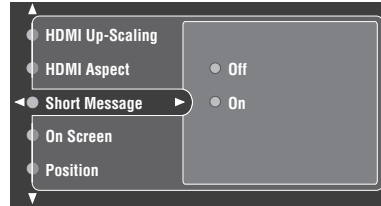

- Select “On” to activate the short message display function. The contents of the front panel display appear at the bottom of the screen each time you operate this unit.
- Select “Off” to deactivate the short message display function.

**Note**

The short message display does not appear in the following cases:

- when the component video signals with 720p, 1080i or 1080p resolutions are input
- When HDMI video signals are input

■ **On Screen (On-screen display time)**

Use this feature to set the amount of time to display the XM Satellite Radio information, iPod or NET/USB menu on the video monitor after you perform a certain operation.

Choices: Always, 10sec, **30sec**

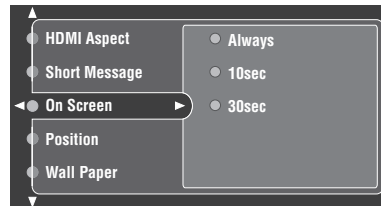

- Select “Always” to display the menu screen unceasingly during an operation.
- Select “10sec” to turn off the menu screen 10 seconds after you perform a certain operation.
- Select “30sec” to turn off the menu screen 30 seconds after you perform a certain operation.

**Position (GUI screen position)**

Use this feature to adjust the vertical and horizontal position of the GUI screen.

Control range: -5 (downward/left) to +5 (upward/right)

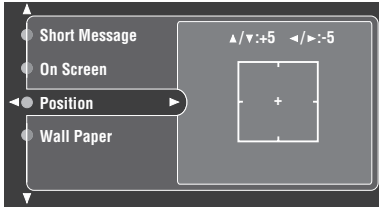

- Press ▲ to raise the position of the GUI display.
- Press ▼ to lower the position of the GUI display.
- Press ▶ to shift the position of the GUI display to the right.
- Press ◀ to shift the position of the GUI display to the left.

**Wall Paper (Wall paper)**

Use this feature to display the wall paper or gray background in your video monitor when there is no video signal being input.

Choices: None, Yes, Gray

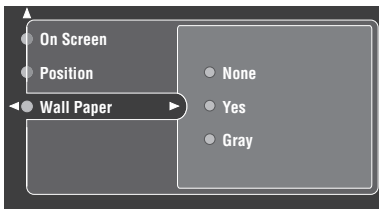

- Select "None" not to display any background in your video monitor.
- Select "Yes" to display a background image (the photograph of a piano) in your monitor when there is no video signal being input.
- Select "Gray" to display a gray background in your monitor when there is no video signal being input.

**Note**

When "Conversion" is set to "Off", no background is displayed even if "Wall Paper" is set to "Yes".

**Manual Setup (Basic)**

Use this menu to manually adjust any speaker setting.

- 1 Set the operation mode selector to AMP and then press SET MENU on the remote control.



- 2 Press ▲ / ▼ on the remote control to select "Manual Setup" and then press ▶.

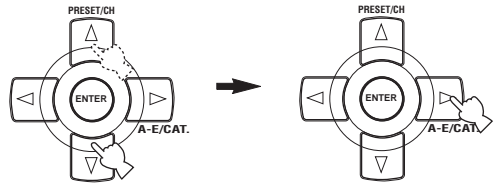

- 3 Press ▲ / ▼ / ◀ / ▶ on the remote control to select "Basic" and then press ▶.

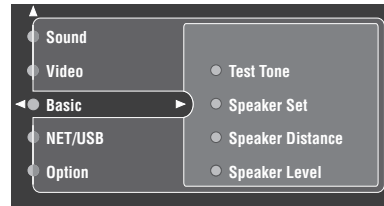
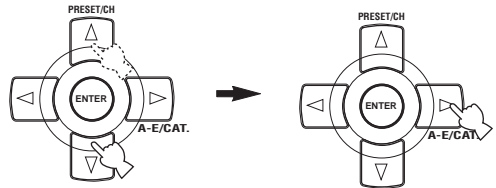

- 4 Select the desired parameters and then press ▶ to access and adjust.

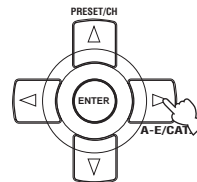



- Most of the parameters described in the basic menu are set automatically when you run “Auto Setup”. You can use the basic menu to make further adjustments, but we recommend running “Auto Setup” first.
- You can reset these parameters by performing the “Auto Setup” procedure (see page 35).

### ■ Test Tone (Test tone)

Turns the test tone output on or off for “Speaker Set”, “Speaker Distance” and “Speaker Level” settings.

Choices: **Off**, **On**

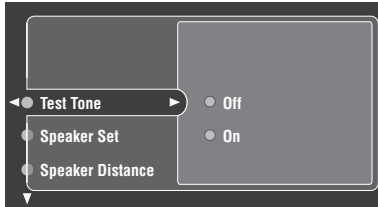

If you use a handheld sound pressure level meter, hold at arm’s length and point upwards so that the meter is in the listening position. With the meter set to the 70 dB scale and to C SLOW, calibrate each speaker to 75 dB.

#### Notes

- Loud test tones will be output when “On” is selected. In this case, make sure no children are present in the listening room.
- If you select “On” and enter the “Speaker Set”, “Speaker Level” or “Speaker Distance” menu, the test tone is output from the selected speakers.

### ■ Speaker Set (Speaker settings)

Use to manually adjust any speaker setting.

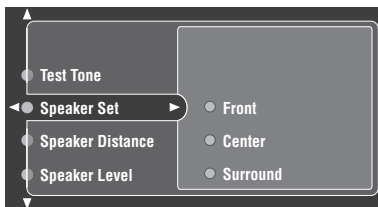

- If you are not satisfied with the bass sounds from your speakers, you can change these settings according to your preference.
- When the diameter of the woofer section of the speaker unit is larger than 16 cm (6.5 in), set the correspondent speaker setting parameter to “Large”.

### Front (Front speakers)

Choices: **Large**, **Small**



- Select “Large” (large) if you have large front speakers that reproduce low-frequency signals effectively. All the front left and right channel signals are directed to the front left and right speakers.
- Select “Small” (small) if you have small front speakers that do not reproduce low-frequency signals effectively. The low-frequency signals of the front left and right channels are directed to the speakers selected in “Bass Out” (see page 107).

#### Notes

- When “Bass Out” is set to “Front” (see page 107), the LFE signals found in Dolby Digital or DTS sources, the low-frequency signals of the front left and right channels, and the low-frequency signals of other speakers set to “Small” are all directed to the front left and right speakers regardless of the “FRONT SP” setting.
- When “Bass Out” is set to “Front” (see page 107), you can select only “Large” in “Front”. If the value of “Front” is set to other than “Large” in advance, this unit change the value to “Large” automatically.

### Center (Center speaker)

Choices: **Large**, **Small**, **None**

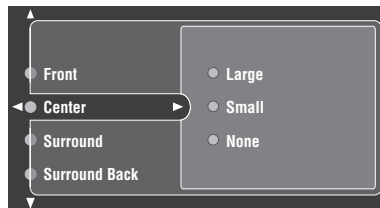

- Select “Large” (large) if you have a large center speaker that reproduces low-frequency signals effectively. All the center channel signals are directed to the center speaker.
- Select “Small” (small) if you have a small center speaker that does not reproduce low-frequency signals effectively. The low-frequency signals of the center channel are directed to the speakers selected in “Bass Out”.
- Select “None” (none) if you did not connect a center speaker. The center channel signals are directed to the front left and right speakers.

### Surround (Surround left/right speakers)

Choices: Large, **Small**, None



- Select “Large” (large) if you have large surround left and right speakers that reproduce low-frequency signals effectively. All the surround channel signals are directed to the surround left and right speakers.
- Select “Small” (small) if you have small surround left and right speakers that do not reproduce low-frequency signals effectively. The low-frequency signals of the surround left and right channels are directed to the speakers selected in “LFE/BASS OUT”.
- Select “None” (none) if you did not connect surround speakers. This unit is set to the Virtual CINEMA DSP mode (see page 51) and “Surround Back” is automatically set to “None”.

### Surround Back (Surround back left/right speakers)

Choices: Large x1, Small x1, **Small x2**, Large x2, None

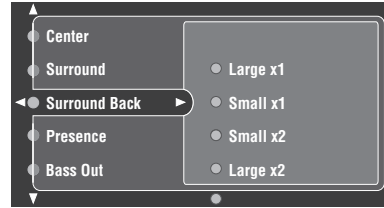

- Select “Large x1” (large x 1) if you have a large surround back speaker that reproduces low-frequency signals effectively. All the surround back left and right channel signals are directed to the surround back left speaker.
- Select “Small x1” (small x 1) if you have a small surround back speaker that does not reproduce low-frequency signals effectively. The low-frequency signals of the surround back left and right channels are directed to the speakers selected in “LFE/BASS OUT” and the rest of the signals are directed to the surround back left speaker.
- Select “Small x2” (small x 2) if you have two small surround back speakers that do not reproduce low-frequency signals effectively. The low-frequency signals of the surround back left and right channels are directed to the speakers selected in “LFE/BASS OUT”.
- Select “Large x2” (large x 2) if you have two large surround back speakers that reproduce low-frequency signals effectively. All the surround back left and right channel signals are directed to the surround back left and right speakers.
- Select “None” (none) if you did not connect surround back speakers. The surround back channel signals are directed to the surround left and right speakers.

### Presence (Presence speakers)

Use this feature if you want to use the presence speakers connected to this unit.

Choices: Yes, **None**

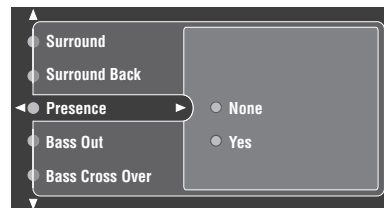

- Select “NONE” (none) if you did not connect presence speakers.
- Select “YES” (yes) if you connected presence speakers and want to use them.

**Bass Out (Bass out)**

Use this feature to select the speakers that output the LFE (low-frequency effect) and the low-frequency signals.

Choices: **Both**, SWFR, Front

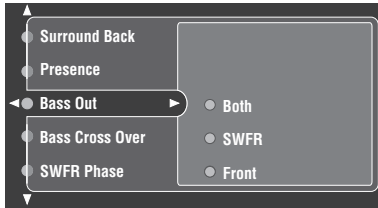

**Notes**

- Select “Both” (both) if you connected a subwoofer. The low-frequency signals of any source are output from the subwoofer. The LFE signals as well as the low-frequency signals of other speakers set to “Small” are directed to the subwoofer. The low-frequency signals of the front left and right channels are directed to the front left and right speakers and the subwoofer regardless of the “Front” setting (see page 107).
- Select “SWFR” (subwoofer) if you connected a subwoofer. The LFE signals as well as the low-frequency signals of other speakers set to “Small” are directed to the subwoofer.
- Select “Front” (front) if you did not connect a subwoofer. The LFE signals, the low-frequency signals of the front left and right channels, and the low-frequency signals of other speakers set to “Small” are all directed to the front left and right speakers regardless of the “Front” setting (see page 107).

**Bass Cross Over (Bass cross over)**

Use this feature to select the crossover frequency of all the speakers set to “Small” or to “None” in “Speaker Set” (see pages 105 and 106). All frequencies below the selected frequency will be sent to the subwoofer or to the speakers set to “Large” in “Speaker Set” (see pages 105 and 106).

Choices: 40Hz, 60Hz, **80Hz**, 90Hz, 100Hz, 110Hz, 120Hz, 160Hz, 200Hz

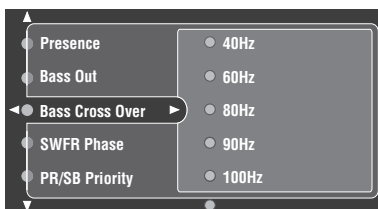

**SWFR Phase (Subwoofer Phase)**

Use this feature to switch the phase of your subwoofer if bass sounds are lacking or unclear.

Choices: **Normal**, Reverse

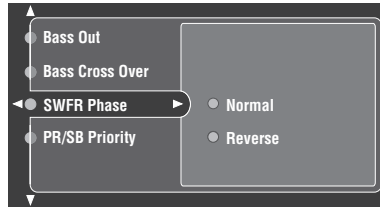

- Select “Normal” if you do not want to reverse the phase of your subwoofer.
- Select “Reverse” to reverse the phase of your subwoofer.

**PR/SB Priority (Presence/surround back speaker priority)**

Use this feature to prioritize either the presence or the surround back speakers when playing sources that contain surround back channel signals using the CINEMA DSP sound field programs.

Choices: Presence, **Surround Back**

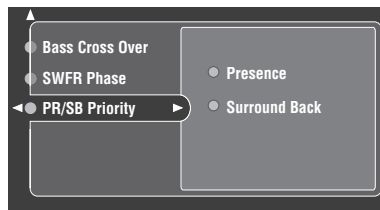

- Select “Presence” to use the presence speakers even when surround back channel signals are input. The signals for the surround back channel will be output from the surround speakers.
- Select “Surround Back” to use the surround back speakers when surround back channel signals are detected in a CINEMA DSP program. The presence channel signals are output from the front speakers.

## ■ Speaker Distance (Speaker distance)

Use this feature to manually adjust the distance of each speaker and the delay applied to the respective channel. Ideally, each speaker should be the same distance from the main listening position. However, this is not possible in most home situations. Thus, a certain amount of delay must be applied to the sound from each speaker so that all sounds will arrive at the listening position at the same time.

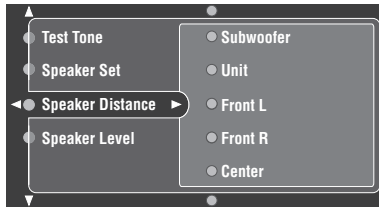

### Speaker distances

Control range: 0.30 to 24.00 m (1.0 to 80.0 ft)

Initial setting:

Front L/Front R/Subwoofer/Presence L/

Presence R/Subwoofer: 3.00 m (10.0 ft)

CENTER: 2.60 m (8.5 ft)

Surround L/Surround R/Surround Back L/

Surround Back R: 2.40 m (8.0 ft)

Control step: 0.1 m (0.5 ft)

- Select “Front L” to adjust the distance of the front left speaker.
- Select “Front R” to adjust the distance of the front right speaker.
- Select “Center” to adjust the distance of the center speaker.
- Select “Surround L” to adjust the distance of the surround left speaker.
- Select “Surround R” to adjust the distance of the surround right speaker.
- Select “Surround Back L” to adjust the distance of the surround back left speaker.
- Select “Surround Back R” to adjust the distance of the surround back right speaker.
- Select “Presence L” to adjust the distance of the presence left speaker.
- Select “Presence R” to adjust the distance of the presence right speaker.
- Select “Subwoofer” to adjust the distance of the subwoofer.

### Notes

- You cannot adjust the distance of speakers set to “None” in Speaker Set.
- If you are only using one surround back speaker, connect it to the SURROUND BACK (SINGLE) jack, and adjust the distance in “Surround Back L”.
- “Center”, “Surround L”, “Surround R”, “Surround Back L”, “Surround Back R”, “Subwoofer”, “Presence L” and “Presence R” cannot be adjusted if “Center” (see page 105), “Surround” (see page 106), “Surround Back” (see page 106), “Bass Out” (see page 107) and “Presence” (see page 106) are set to “None” respectively.
- Instead of “Surround Back L” and “Surround Back R”, “Surround Back” is displayed if “Surround Back” is set to either “Small x1” or “Large x1” (see page 106).

### Unit (Unit)

Selects the unit for displaying the values of “Speaker Distance” parameter.

Choices: Meter (m), Feet (ft)

Initial setting: Feet (U.S.A. and Canada models)

Meter (Other models)

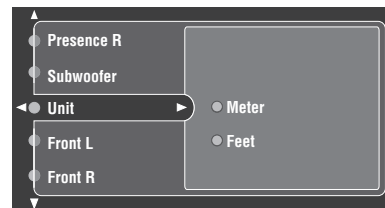

- Select “Meter” to input speaker distances in meters.
- Select “Feet” to input speaker distances in feet.



### ■ Speaker Level (Speaker level)

Use this feature to manually balance the speaker levels between the front left or surround left speakers and each speaker selected in “SPEAKER SET” (see page 105).

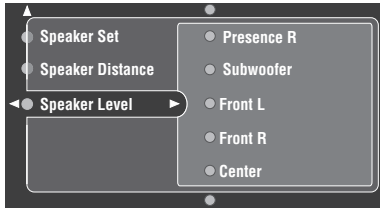

Control range: -10.0 dB to +10.0 dB

Initial setting:

Front L/Front R/Subwoofer/Presence L/

Presence R/Subwoofer: 0.0 dB

CENTER/Surround L/Surround R/Surround Back L/

Surround Back R: -1.0 dB

Control step: 0.5 dB

- Select “Front L” to adjust the balance of the front left speaker.
- Select “Front R” to adjust the balance of the front right speaker.
- Select “Center” to adjust the balance of the center speaker.
- Select “Surround L” to adjust the balance of the surround left speaker.
- Select “Surround R” to adjust the balance of the surround right speaker.
- Select “Surround Back L” to adjust the balance of the surround back left speaker.
- Select “Surround Back R” to adjust the balance of the surround back right speaker.
- Select “Presence L” to adjust the balance of the presence left speaker.
- Select “Presence R” to adjust the balance of the presence right speaker.
- Select “Subwoofer” to adjust the balance of the subwoofer.

#### Notes

- You cannot adjust the level of channels set to “None” in Speaker Set.
- If you are only using one surround back speaker, connect it to the SURROUND BACK (SINGLE) jack, and adjust the balance in “Surround Back L”.

## Manual Setup (NET/USB)

Use this menu to adjust the network and USB system parameters.

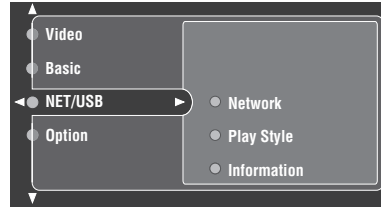

### ■ Network (Network settings)

Use this feature to view the network parameters (IP address, etc.) or to change them manually.

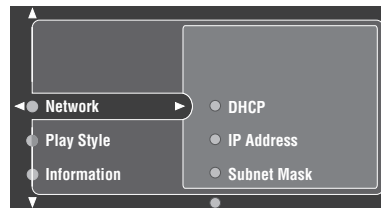

#### Note

The above display is an example.

#### DHCP (DHCP setting)

When this parameter is set to “ON”, network parameters for “IP Address”, “Subnet Mask”, “Default Gateway”, “DNS Server (P)” and “DNS Server (S)” obtained from a DHCP enabled router are displayed. If DHCP server function is not available, set this parameter to “Off” to configure the network parameters manually.

Choices: **On**, Off

#### IP Address (IP address)

Use this parameter to specify an IP address assigned to this unit. This value must not duplicate the one used for other devices in the target network.

#### Subnet Mask (Subnet mask)

Use this parameter to specify the subnet mask value assigned to this unit.



For most of the cases, the subnet mask value can be set as “255.255.255.0”.

#### Default Gateway (Default gateway)

Use this parameter to specify the IP address of the default gateway.

**DNS Server (P) (Primary DNS server)**  
**DNS Server (S) (Secondary DNS server)**

Use this parameter to specify the IP address of the primary and secondary DNS (Domain Name System) servers.

**Note**

If you have only one DNS address, enter the DNS address in “DNS Server (P)”. If you have two or more DNS addresses, enter one of them in “DNS Server (P)” and another in “DNS Server (S)”.

**Setup (Setup)**

Select “Setup” to confirm the settings of the “Network” parameters.

**1 Press  $\Delta$  /  $\nabla$  on the remote control repeatedly and then press  $\triangleright$  to select and enter the desired network parameter.**

**Note**

When “DHCP” is set to “ON”, you cannot select and adjust any other network settings. To specify the other parameters, you need to first set “DHCP” to “OFF”.

**2 To specify the parameter, press  $\Delta$  /  $\nabla$  repeatedly to change the number and press  $\triangleleft$  /  $\triangleright$  to select the digit to change.**

**3 Press ENTER to confirm the parameter.**

**4 Repeat steps 1 through 3 to configure each network parameter.**

**5 Select “Setup” and then press ENTER to finish configuration.**

**Note**

In case you have changed your network configuration, you may need to reconfigure the network settings again.



You can reset the network settings of this unit to the initial factory settings by using “N-RESET” in the advanced setup menu (see page 136).

**■ Play Style (Playback styles)**

Use this feature to adjust the playback style according to your preference. You can shuffle songs in a random order or repeat one specific song or a sequence of songs.

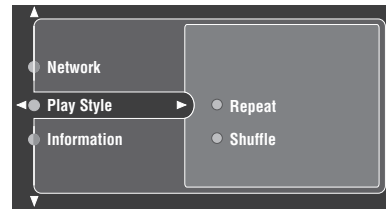

**Repeat (Repeat)**

Use this feature to set this unit to repeat one song or a sequence of songs.

Choices: **Off**, Single, All

- Select “Off” to deactivate this feature.
- Select “Single” to set this unit to repeat one song.
- Select “All” to set this unit to repeat a sequence of songs.

**Notes**

- When “Repeat” is set to a setting other than “Off”, “ $\text{↺}$ ” or “ $\text{↻}$ ” appears in the top right corner of the playback status screen while one song or a sequence of songs are being repeated.
- If “Repeat” is set to “Single”, the setting will be reset to “Off” when the main zone, Zone 2 and Zone 3 are turned off.

**Shuffle (Shuffle)**

Use this feature to set this unit to play songs or albums in a random order.

Choices: **Off**, On

- Select “Off” to deactivate this feature.
- Select “On” to set this unit to play songs or albums in a random order.

**Note**

When “Shuffle” is set to “On”, “ $\text{↻}$ ” appears in the top right corner of the playback status screen while songs or albums are being shuffled.

### Information (Network information)

Use this feature to display the network system information.

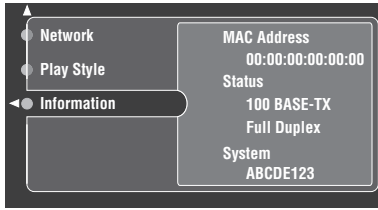

**Note**

The above display is an example.

#### MAC Address (MAC (Media Access Control) address)

This information displays the MAC address that is assigned to this unit.

#### Status (Network status)

This information displays the current link status of the network.

Display status: 10BASE-T, 100BASE-TX, Full Duplex, Half Duplex, No Link

**Note**

“No Link” appears when network connection is not made.

#### System (System ID)

This information displays the system ID that is assigned to this unit.

## Manual Setup (Option)

This menu adjusts the optional system settings.

- 1 Set the operation mode selector to AMP and then press SET MENU on the remote control.



- 2 Press  $\Delta$  /  $\nabla$  on the remote control to select “Manual Setup” and then press  $\triangleright$ .

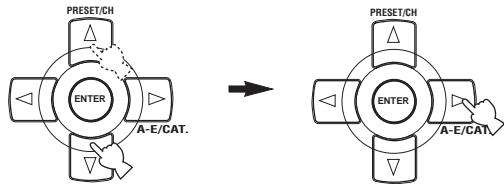

- 3 Press  $\Delta$  /  $\nabla$  /  $\triangleleft$  /  $\triangleright$  on the remote control to select “Option” and then press  $\triangleright$ .

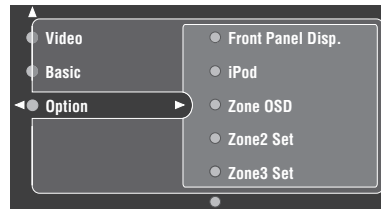
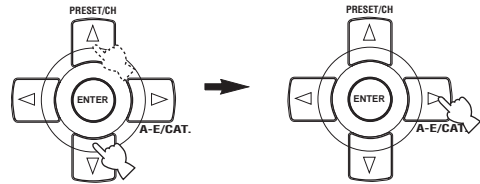

- 4 Select the desired parameters and then press  $\triangleright$  to access and adjust.

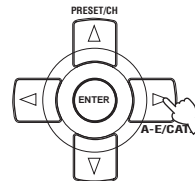

## ■ Front Panel Disp. (Front panel display setting)

### Dimmer (Dimmer)

Use this feature to adjust the brightness of the front panel display.

Control range: -4 to 0

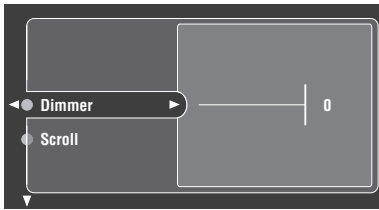

### Scroll (Front panel display message scroll)

Use this feature to set whether to display the information (such as song title or channel name) in the front panel display in a continuous manner or by the first 14 alphanumeric characters after scrolling all characters once when “XM”, “DOCK” or “NET/USB” is selected as the input source.

Choices: **Continue**, Once

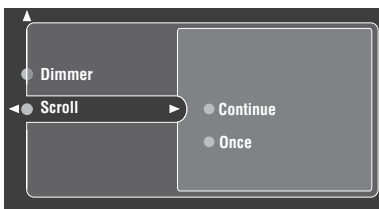

- Select “Continue” to display the operation status in the front panel display in a continuous manner.
- Select “Once” to display the operation status in the front panel display by the first 14 alphanumeric characters after scrolling all characters once.

## ■ iPod (iPod settings)

### Standby Charge

#### (iPod Charge on the standby mode)

Use this feature to select whether this unit charges the battery of the stationed iPod or not when this unit is in the standby mode (see page 75).

Choices: Off, **Auto**

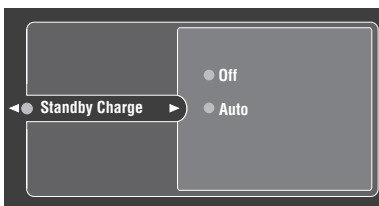

- Select “Off” to charge the battery of the stationed iPod only when this unit is turned on.
- Select “Auto” to charge the battery of the stationed iPod when this unit is turned on and in the standby mode.

## ■ Zone OSD (on-screen display)

Use this feature to display the operational status of Zone 2 as well as Zone 3 on the Zone 2 video monitor connected to the ZONE VIDEO jacks on the rear panel of this unit. The Zone 2 and Zone 3 information to be displayed is listed as follows:

- The input source of Zone 2 and Zone 3
- The volume level of Zone 2 and Zone 3
- The audio mute status of Zone 2 and Zone 3
- The tonal quality status of Zone 2 and Zone 3
- The XM Satellite Radio information when XM is selected as the input source of Zone 2 and Zone 3

Choices: Off, Zone2, **Zone2&Zone3**

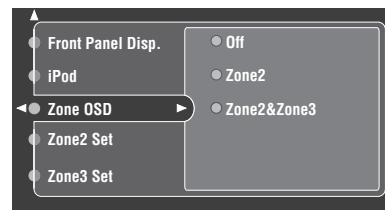

- Select “Off” not to display any operational status of Zone 2 and Zone 3 on the Zone 2 video monitor.
- Select “Zone2” to display the operational status of Zone 2 only on the Zone 2 video monitor.
- Select “Zone2&Zone3” to display the operational status of Zone 2 and Zone 3 on the Zone 2 video monitor.

### Notes

- If “Zone OSD” is set to “Zone2&Zone3”, changes to the operational status of Zone 3 is displayed on the Zone 2 video monitor. For example, if the input source of Zone 3 is changed while you are watching TV in Zone 2, the name of the changed input source of Zone 3 is displayed on your TV in Zone 2.
- If “Zone OSD” is set to “Zone2&Zone3”, the display contents of Zone 2 and Zone 3 depends on whether or not Zone 2 and Zone 3 are turned on with ZONE 2 ON/OFF and ZONE 3 ON/OFF on the front panel (see page 131).
  - If both Zone 2 and Zone 3 are turned on, the video signals of the current input source of Zone 2 and the corresponding OSD are displayed on the Zone 2 video monitor.
  - If Zone 2 is turned off and Zone 3 is turned on, only the corresponding OSD is displayed in the gray background regardless of the REC OUT/ZONE 2 status on the front panel.
  - If Zone 2 is turned on and Zone 3 is turned off, the video signals of the current input source of Zone 2 and the corresponding OSD are displayed on the Zone 2 video monitor.
  - If both Zone 2 and Zone 3 are turned off, no video signals and no OSD are displayed on the Zone 2 video monitor.

**Zone2 Set/Zone3 Set  
(Zone 2/Zone 3 setting)**

**Zone2 Amplifier/Zone3 Amplifier  
(Zone 2/Zone 3 amplifier)**

Use to select how the Zone 2 and/or Zone 3 speakers are amplified.

Choices: **EXT**, INT:[SP1], INT:[SP2], INT:Both

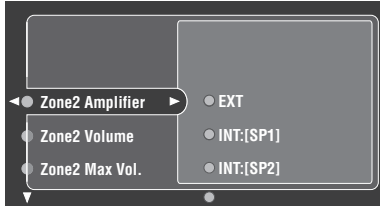

- Select “EXT” if you want to connect your Zone 2 or Zone 3 speakers through an external amplifier connected to the ZONE 2 OUTPUT or ZONE 3 OUTPUT jacks on the rear panel of this unit.
- Select “INT:[SP1]” to use the internal surround back amplifier of this unit when you want to connect your Zone 2 or Zone 3 speakers directly to the SP1 speaker terminals on the rear panel of this unit.
- Select “INT:[SP2]” to use the internal surround amplifier of this unit when you want to connect your Zone 2 or Zone 3 speakers directly to the SP2 speaker terminals on the rear panel of this unit.
- Select “INT:Both” to use the internal surround and surround back amplifiers of this unit when you want to connect your Zone 2 or Zone 3 speakers directly to both the SP1 and the SP2 speaker terminals on the rear panel of this unit.

**Notes**

- When “BI-AMP” is set to “ON” in the “ADVANCED SETUP” menu, “INT:[SP1]”, “INT:[SP2]” and “INT:Both” cannot be selected.
- When “INT:Both” is selected for “ZONE2 AMP”, only “EXT” can be selected for “ZONE3 AMP”.
- When “INT:Both” is selected for “ZONE3 AMP”, only “EXT” can be selected for “ZONE2 AMP”.
- When you set “ZONE2 AMP” or “ZONE3 AMP” to “INT:[SP1]” or “INT:[SP2]” and the corresponding zone is turned on, no sound is output from the surround back speakers.
- When you set “ZONE2 AMP” or “ZONE3 AMP” to “INT:Both” and the corresponding zone is turned on, no sound is output from both the surround speakers and the surround back speakers in the main zone.
- When both “ZONE2 AMP” and “ZONE3 AMP” are set to “INT:[SP1]” or “INT:[SP2]” and Zone 2 and Zone 3 are turned on, no sound is output from both the surround speakers and the surround back speakers in the main zone.
- When you use internal amplifiers for Zone 2 or Zone 3, some surround field programs may not work in the same way as when you do not use the internal amplifiers for Zone 2 or Zone 3.

**Zone2 Volume/Zone3 Volume  
(Zone 2/Zone 3 volume)**

Use this feature to select how the volume control will operate with regard to the ZONE 2 OUTPUT or ZONE 3 OUTPUT jacks.

Choices: Fixed, **Variable**

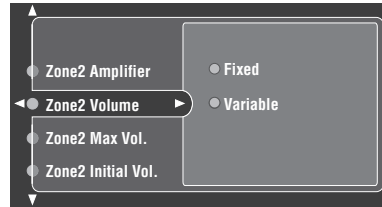

- Select “Fixed” to fix the ZONE 3 OUTPUT volume level to a standard line level.
- Select “Variable” to adjust the ZONE 3 OUTPUT volume simultaneously using VOL +/- on the remote control.

**Zone2 Max Vol./Zone3 Max Vol.  
(Zone 2/Zone 3 Maximum volume)**

Use this feature to set the maximum volume level in the Zone 2 or Zone 3.

Control range: **16.5 dB**, 15.0 dB to –30.0 dB

Control step: 5.0 dB

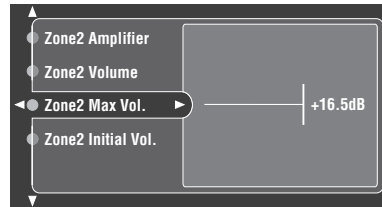

**Note**

The “Zone2 Max Vol.” or “Zone3 Max Vol.” setting takes priority over the “Zone2 Initial Vol.” or “Zone3 Initial Vol.” setting. For example, “Zone2 Initial Vol.” is set to –20.0 dB and then “Zone2 Max Vol.” is set to –30.0 dB, the volume level is automatically set to –30.0 dB when you turn on the power of this unit next time.\*

ADVANCED  
OPERATION

**Zone2 Initial Vol./Zone3 Initial Vol.  
(Zone 2/Zone 3 Initial volume)**

Use this feature to set the volume level of Zone 2 or Zone 3 when the power of this unit is turned on.  
 Choices: **Off**, -80 dB to +16.5 dB  
 Control step: 0.5 dB

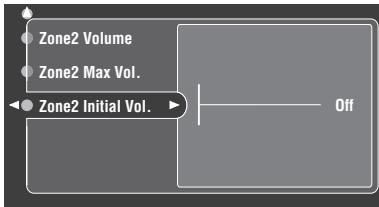

**Note**

The “Zone2 Max Vol.” or “Zone3 Max Vol.” setting takes priority over the “Zone2 Initial Vol.” or “Zone3 Initial Vol.” setting.

**Sur.Initialize (Surround initialize)**

Use this feature to initialize the parameters for each sound field program within sound field program groups. When you initialize a sound field program group, all of the parameter values within that group revert to their initial settings.

Adjusted sound field parameter settings are displayed in blue.

Choices: CLASSICAL, LIVE/CLUB, ENTERTAINMENT, MOVIE, STEREO, SUR. DECODE, All

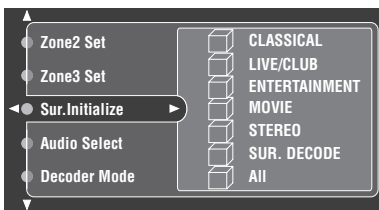

- Press  $\Delta$  /  $\nabla$  /  $\leftarrow$  /  $\rightarrow$  to select the sound field program you want to initialize and then press ENTER.
- Select “All” to initialize settings for all sound field program parameters.

**Note**

Sound field program groups cannot be initialized when “Memory Guard” is set to “On” (see page 114).

**Audio Select (Default Audio input jack select)**

Use this feature to designate the default Audio input jack select setting when you turn on the power of this unit.  
 Choices: **Auto**, Last

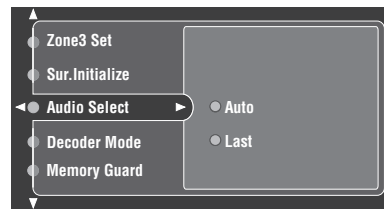

- Select “Auto” if you want this unit to automatically detect the type of input signals and select the appropriate Audio input jack select setting.
- Select “Last” if you want this unit to automatically select the last selected Audio input jack select setting used for the connected input source.

**Decoder Mode (Default decoder mode)**

You can select the decoder used by this unit.  
 Choices: **Auto**, Last

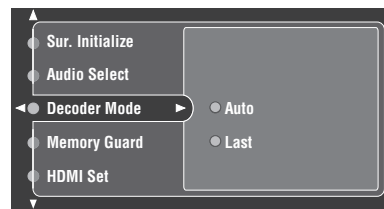

- Select “Auto” if you want this unit to automatically detect input signal types and select the appropriate decoder.
- Select “Last” if you want this unit to automatically select the last decoder used for the connected source.

**Memory Guard (Memory Guard)**

Use this feature to prevent accidental changes to DSP program parameter values and other system settings.  
 Choices: **Off**, On

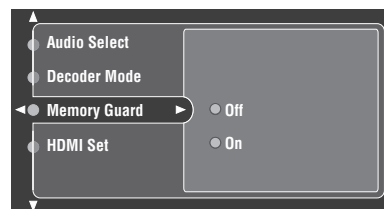

Select “On” to protect:

- DSP program parameters
- All menu items except “Memory Guard” and “System Memory” – “Load”.
- The start and reload of the “Auto Setup” procedure.



When you select the protected parameter, “” appears at the bottom left of the GUI screen.

### ■ HDMI Set (HDMI settings)

Use this feature to adjust the HDMI support audio.

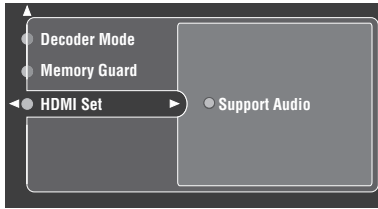

#### Support Audio (Support audio)

Use this feature to select whether to play back HDMI audio signals on this unit or on another HDMI component connected to the HDMI OUT jack on the rear panel of this unit.

Choices: **RX-V2700**, Other

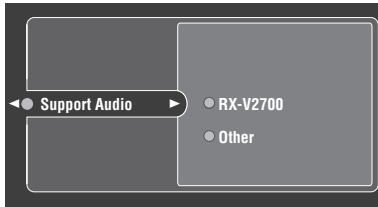

- Select “RX-V2700” to play back HDMI audio signals on this unit. The HDMI audio signals input at the HDMI IN jacks of this unit are not output to the HDMI component connected to the HDMI OUT jack on the rear panel of this unit.
- Select “Other” to play back HDMI audio signals on another HDMI component connected to the HDMI OUT jack.

#### Note

The HDMI video signals input at the HDMI IN 1, HDMI IN 2 or HDMI IN 3 jack of this unit are always output at the HDMI OUT jack of this unit.

## System Memory

Use this feature to save up to six of your favorite settings that can be easily recalled when needed. You can save settings such as the following:

- Sound field program parameters
- Speaker settings
- Speaker channel settings
- LFE level
- Dynamic range settings
- Parametric equalizer settings

### ■ To save settings

- 1 Set the operation mode selector to AMP and then press SET MENU on the remote control.



- 2 Press  $\Delta / \nabla / \leftarrow / \rightarrow$  on the remote control repeatedly to select “System Memory” and then press  $\triangleright$ .

- 3 Select “Save” and then press ENTER.

The display of the current settings appears in the GUI screen.

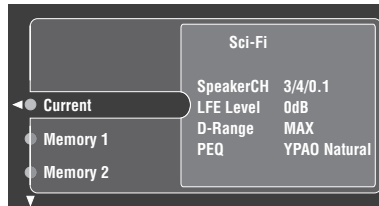

- 4 Press  $\Delta / \nabla$  on the remote control repeatedly to select the desired memory number to save the current settings of this unit and then press  $\triangleright$ .

“Save: ENTER” appears in the bottom right corner of the window.

- 5 Press ENTER to save the current settings of this unit.

■ To load settings

- 1 Set the operation mode selector to AMP and then press SET MENU on the remote control.



- 2 Press  $\Delta$  /  $\nabla$  /  $\triangleleft$  /  $\triangleright$  on the remote control repeatedly to select “System Memory” and then press  $\triangleright$ .

- 3 Select “Load” and then press ENTER.

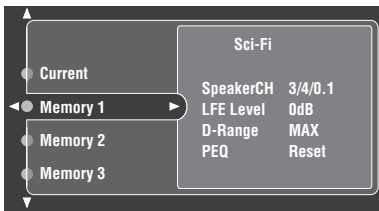

- 4 Press  $\Delta$  /  $\nabla$  on the remote control repeatedly to select the desired memory number to load and then press  $\triangleright$ .

“Load: ENTER” appears in the bottom right corner of the window.

- 5 Press ENTER to load settings.



“Memory 1” and “Memory 2” settings can be recalled simply by pressing MEMORY 1 or MEMORY 2 on the remote control. When you press MEMORY 1, “Load Memory 1? Yes:Press Again” appears in the GUI and “Press MEMORY 1!” appears in the front panel display. Press MEMORY 1 once more to recall the settings.



When you press MEMORY 2, “Load Memory 2? Yes:Press Again” appears in the GUI and “Press MEMORY 2!” appears in the front panel display. Press MEMORY 2 once more to recall the settings.

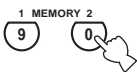

## Signal Info. (Input signal information)

You can display the format, sampling frequency, channel, bit rate and flag data of the current input signal.

You can display the format, sampling frequency, channel, bit rate and flag data of the current input signal.

- 1 Set the operation mode selector to AMP and then press SET MENU on the remote control. The top display appears.

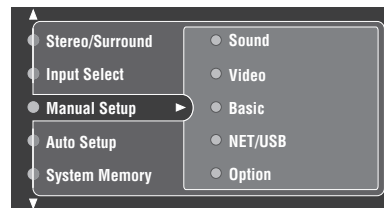
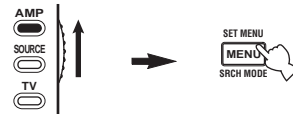

- 2 Press  $\Delta$  /  $\nabla$  repeatedly to select “Signal Info.”.

The audio information about the input source appears in the GUI screen.

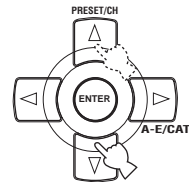

- 3 Press  $\triangleleft$  /  $\triangleright$  repeatedly to select “Audio Info.” or “Video Info.”.

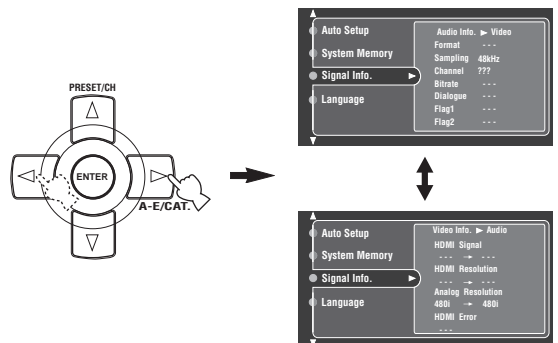



**Audio information**

**Format (Signal format)**

Signal format. When this unit cannot detect a digital signal, it automatically switches to analog input.

**Note**

“---” appears when this unit cannot detect any signals.

**Sampling (Sampling frequency)**

The number of samples per second taken from a continuous signal to make a discrete signal.

**Note**

“---” appears when this unit cannot detect the sampling frequency.

**Channel (Input channel)**

The number of source channels in the input signal (front/surround/LFE). For example, a multi-channel soundtrack with 3 front channels, 2 surround channels and LFE, is displayed as “3/2/0.1”.

**Note**

“---” appears when there is no source channel available.

**Bitrate (Bit rate)**

The number of bits passing a given point per second.

**Note**

“---” appears when this unit cannot detect the bit rate.

**Dialogue**

**(Dialogue normalization level)**

The dialogue normalization level preset to the current input Dolby Digital and DTS signal.

**Flag1/Flag2 (Signal flags)**

Flag data encoded in DTS, Dolby Digital, or PCM signals that cue this unit to automatically switch decoders.

**Video information**

**HDMI Signal (HDMI signal type)**

Type of the source video signals and the video signals output at the HDMI OUT jack of this unit.

**HDMI Resolution (HDMI resolution)**

Resolution of the source video signals and the video signals output at the HDMI IN jacks of this unit.

**Analog Resolution (Analog resolution)**

Resolution of the source video signals and the analog video signals output at the COMPONENT MONITOR OUT jacks of this unit.

**HDMI Error (HDMI Error)**

Error message for HDMI sources or connected HDMI devices. See page 144 for details.

**Language**

Use this feature to select the language of the menu items and messages that appears in the GUI (graphical user interface) screen of this unit.

Choices: **English** (English), 日本語 (Japanese), Français (French), Deutsch (German), Español (Spanish), Русский (Russian)



You can also select the GUI language using the “GUI LANGUAGE” parameter in “ADVANCED SETUP” in the front panel display (see page 136).

- 1 Set the operation mode selector to AMP and then press SET MENU on the remote control.**  
The top display appears.

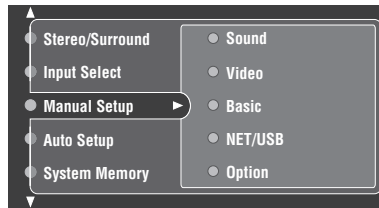

- 2 Press  $\nabla$  on the remote control repeatedly to select Language and then press  $\triangleright$ .**



- 3 Press  $\Delta$  /  $\nabla$  on the remote control repeatedly to select the language of your choice.**
- 4 Press ENTER to confirm your selection.**

# REMOTE CONTROL FEATURES

In addition to controlling this unit, the remote control can also operate other audiovisual components made by YAMAHA and other manufacturers. To control your TV or other components, you must set up the appropriate remote control code for each input source (see page 120).

## Controlling this unit, a TV, or other components

### ■ Controlling this unit

Set the operation mode selector to AMP to control this unit (see page 8).

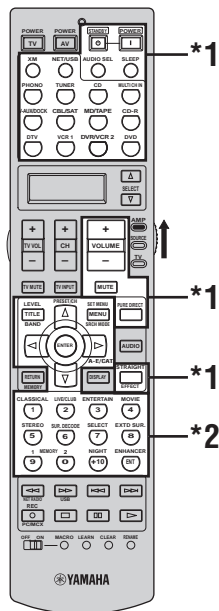

(U.S.A. model)

### ■ Controlling a TV

Set the operation mode selector to TV to control your TV. To control your TV, you must set the appropriate remote control code for DTV or PHONO (see page 120). When you set the remote control codes for both DTV and PHONO, priority is given to the one set for DTV.

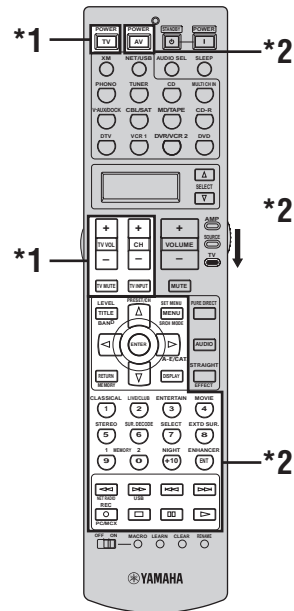

(U.S.A. model)

### Notes

- \*1 These buttons always control this unit regardless of the operation mode selector position.
- \*2 These buttons control this unit only when the component operation mode selector is set to AMP.

### Notes

- \*1 These buttons always control your TV regardless of the operation mode selector position.

Remote control	Digital TV/Cable TV
TV POWER	Turns on or off the power.
TV VOL +/-	Increases or decreases the volume level.
TV MUTE	Mutes the audio output.
TV INPUT	Changes the input source.

- \*2 These buttons control your TV only when the operation mode selector is set to TV. For details, see the "TV" column on page 119.

### ■ Controlling other components

Set the operation mode selector to SOURCE to control other components selected with the input selector buttons. You must set the appropriate remote control code for each input source in advance (see page 120). The following table shows the function of each control button used to control other components assigned to each input selector button. Be advised that some buttons may not correctly operate the selected component.



The remote control has 14 modes (input areas) to control components so that the remote control can operate up to 14 different components.

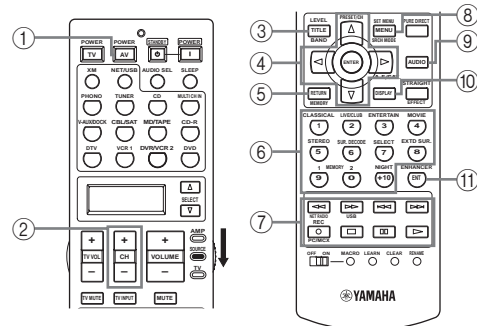

(U.S.A. model)

	DVD player/ DVD recorder	VCR	Cable TV/ Satellite tuner	TV	LD player	CD player	MD recorder/ CD recorder	Tape deck	Tuner	iPod	PC/MCX- 2000/ Internet Radio/USB
① AV POWER	Power *1	Power *1	Power *1	VCR power *2	Power *1	Power *1	Power *1	Power *1	Power *1		
② CH +	TV channel up*3	Channel up	Channel up	Channel up	TV channel up*3	TV channel up*3	TV channel up*3	TV channel up*3	TV channel up*3	TV channel up*3	TV channel up*3
CH -	TV channel down*3	Channel down	Channel down	Channel down	TV channel down*3	TV channel down*3	TV channel down*3	TV channel down*3	TV channel down*3	TV channel down*3	TV channel down*3
③ TITLE	Title	Title	Title	Title					Band		Bookmark*7
④ ENTER	Menu enter		Menu select	Menu select						Subsequent menu	
PRESET/CH ▲	Menu up		Menu up	Menu up					Preset up (1 to 8)	Up	Up
PRESET/CH ▼	Menu down		Menu down	Menu down					Preset down (1 to 8)	Down	Down
A-E/CAT. ◀	Menu left		Menu left	Menu left					Preset down (A to E)	Previous menu*6	Previous menu
A-E/CAT. ▶	Menu right		Menu right	Menu right				Direction A/B	Preset up (A to E)	Subsequent menu*6	Subsequent menu
⑤ RETURN, MEMORY	Return	Return	Return	Return							Memory
⑥ 1-9, 0, +10	Numeric buttons	Numeric buttons	Numeric buttons	Numeric buttons	Numeric buttons	Numeric buttons	Numeric buttons				Numeric buttons*9
⑦ ◀◀	Search backward	Search backward	VCR search backward *2	VCR search backward *2	Search backward	Search backward	Search backward	Search backward		Search backward*4	Select NET RADIO
▶▶	Search forward	Search forward	VCR search forward *2	VCR search forward *2	Search forward	Search forward	Search forward	Search forward		Search forward*4	Select USB
◀◀	Skip backward				Chapter/ Skip backward	Skip backward	Skip backward	Direction back		Skip backward	Skip backward*8
▶▶	Skip forward				Chapter/ Skip forward	Skip forward	Skip forward	Direction forward		Skip forward	Skip forward*8
REC/ DISC SKIP	Disc skip (player) Rec (recorder)	Rec	VCR rec *2	VCR rec *2	Disc skip	Rec	Rec	Rec			Select PC/ MCX
□	Stop	Stop	VCR stop *2	VCR stop *2	Stop	Stop	Stop	Stop		Stop	Stop
⏸	Pause	Pause	VCR pause *2	VCR pause *2	Pause	Pause	Pause	Pause		Pause (Play/ Pause)*5	
▶	Play	Play	VCR play *2	VCR play *2	Play	Play	Play	Play		Play (Play/ Pause)*5	Play
⑧ MENU	Menu		Menu	Menu						Previous menu	Previous menu
⑨ AUDIO	Audio				Audio						
⑩ DISPLAY	Display		Display	Display	Display	Display	Display			Display	Display
⑪ ENT		Enter	Enter/recall	Enter							

**Note**

See page 120 for details about the items marked with asterisk (\*).

ADVANCED  
OPERATION

**Notes**

- \*1 This button is operational only when the original remote control supplied with the component has a POWER button.
- \*2 These buttons operate your VCR only when you set the appropriate remote control code for VCR 1 (see page 120).
- \*3 These buttons always control your TV regardless of the operation mode selector position.
- \*4 Press and hold to search backward or forward.
- \*5 Simple remote mode (see page 75).
- \*6 Menu browse mode only (see page 75).
- \*7 Press and hold to store your favorite Internet Radio stations with bookmarks (see page 80).
- \*8 These buttons are not operational when the Internet Radio is selected as the sub input source of NET/USB.
- \*9 Press 1-8 to assign or recall the preset items (see page 81).

**■ Selecting a component to be controlled**

You can select a component to be controlled independently of the input source selected with the input selector buttons.

Press **SELECT**  $\Delta$  /  $\nabla$  repeatedly to select the desired component.

The name of the component to be controlled appears in the display window on the remote control.



**■ Controlling optional components (Option mode)**

“OPTN” is an optional component control area that can be programmed with remote control functions independently from any input source. This area is useful for programming commands that are to be used only as a part of a macro function or for components that do not have a valid remote control code.

To select the option mode, press **SELECT**  $\nabla$  repeatedly until “OPTN” appears in the display window on the remote control.



**Note**

You cannot set a remote control code for the optional area. See page 122 to program buttons operated within this component control area.

**Setting remote control codes**

You can control other components by setting the appropriate remote control codes. Codes can be set up for each input area. For a complete list of available remote control codes, refer to “LIST OF REMOTE CONTROL CODES” at the end of this manual.

The following table shows the default component (Library: component category) and the remote control code for each input area.

**Remote control code default settings**

Input area	Library (component category)	Manufacturer	Default code
XM	TUNER	YAMAHA	2604
NET/USB	TUNER	YAMAHA	2607
PHONO	TV	-	-
TUNER	TUNER	YAMAHA	2602
CD	CD	YAMAHA	2300
MULTI CH INPUT	DVD	YAMAHA	2100
V-AUX/DOCK	TUNER	YAMAHA	2606
CBL/SAT	CABLE	-	-
MD/TAPE	MD	YAMAHA	2500
CD-R	CD-R	YAMAHA	2400
DTV	TV	-	-
VCR 1	VCR	-	-
DVR/VCR2	DVR	YAMAHA	2807
DVD	DVD	YAMAHA	2100

**Note**

You may not be able to operate your YAMAHA component even if a YAMAHA remote control code is preset as listed above. In this case, try setting another YAMAHA remote control code.

- 1 Set the operation mode selector to SOURCE and then press an input selector button to select the input area you want to set up.**

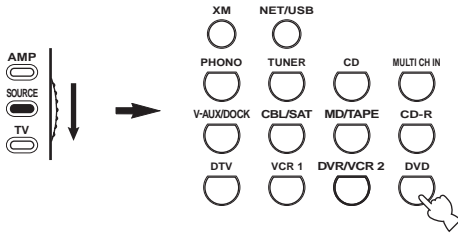

- 2 Press and hold LEARN for about 3 seconds using a ballpoint pen or similar object.**

The library name (ex. L;DVD) and the name of the selected input area (ex. DVD) appear alternately in the display window on the remote control.



- You can set a remote control code of a different type of component to an input area. Press  $\triangleleft$  /  $\triangleright$  repeatedly to change the library (component category).

Library choices: L;DVD, L;DVR, L;LD, L;CD, L;CDR, L;MD, L;TAP (tape), L;TUN (tuner), L;AMP, L;TV, L;CAB (cable), L;SAT (satellite), L;VCR

- If you want to setup for another input area, press the input selector button, or press SELECT  $\triangle$  /  $\nabla$  repeatedly to select the input area.

**Notes**

- Be sure to press and hold LEARN for at least 3 seconds, otherwise the learning process will start.
- If you do not complete each of the following steps within 30 seconds, the setting mode will be automatically canceled. In this case, start over from step 2.

- 3 Press ENTER.**

The four-digit code set for the selected component appears in the display window.

**Note**

0000 appears in the display window if no code has been set.

- 4 Press the numeric buttons to enter the four-digit remote control code for the component you want to use.**

For a complete list of available remote control codes, refer to "LIST OF REMOTE CONTROL CODES" at the end of this manual.

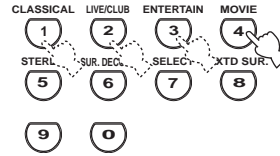

- 5 Press ENTER to set the number.**

"OK" appears in the display window on the remote control if setting was successful.

"NG" appears in the display window on the remote control if the setting was unsuccessful. In this case, start over from step 3.



If you continuously want to set up another code for another component, press the input selector button, or SELECT  $\triangle$  /  $\nabla$  repeatedly to select the component, then repeat steps 2 through 5.

- 6 Press LEARN again to exit from the setup mode.**



- 7 Press  $\triangleright$  or AV POWER to confirm whether you can control your component using the remote control.**

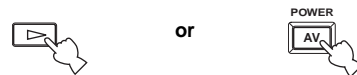

If operation is not possible and the manufacturer of your component has more than one code, try each of them until you find the correct one.

**Notes**

- "ERROR" appears in the display window on the remote control if you press a button not indicated in the respective step, or when you press more than one button simultaneously.
- The supplied remote control does not contain all possible codes for commercially available audio and video components (including YAMAHA components). If operation is not possible with any of the remote control codes, program the new remote control function using the learn feature (see "Programming codes from other remote controls") or use the remote control supplied with the component.
- Functions programmed using the learn feature take priority over remote control code functions.

## Programming codes from other remote controls

You can program remote control codes from other remote controls. Use the learn feature if you want to program functions not included in the basic operations covered by the remote control codes, or an appropriate remote control code is not available. You can program the function of other remote control to the buttons in the highlighted areas in the following illustration. The buttons can be programmed independently for each input area.

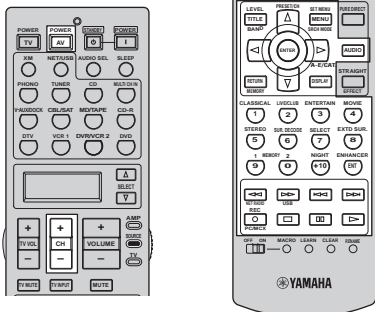

(U.S.A. model)

### Note

The remote control transmits infrared rays. If the other remote control also uses infrared rays, this remote control can learn most of its functions. However, you may not be able to program some special signals or extremely long transmissions. Refer to the operating instructions for the other remote control.

- 1 Set the operation mode selector to **SOURCE** and then press an input selector button to select an input area.

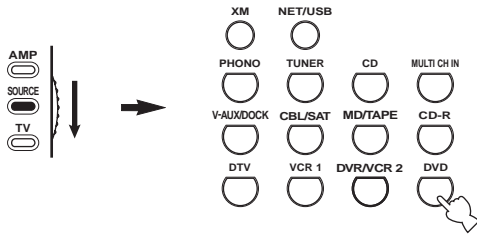

(U.S.A. model)

### Note

Make sure that the operation mode selector is set to SOURCE. When you set the operation mode selector to AMP and program a remote control codes from other remote controls, the programmed key cannot operate the amplifier function of this unit.

- 2 Place this remote control about 5 to 10 cm (2 to 4 in) apart from the other remote control on a flat surface so that their infrared transmitters are aimed at each other.

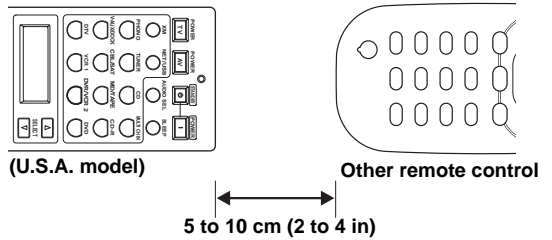

- 3 Press **LEARN** using a ballpoint pen or similar object.

“LEARN” and the name of the selected input area (ex. “DVD”) appear alternately in the display window on the remote control.

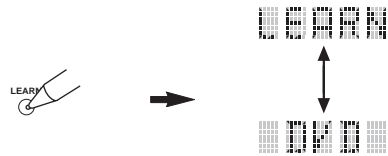

### Notes

- Do not press and hold LEARN. If you hold it down for more than 3 seconds, the remote enters the remote control code setting mode.
- If you do not complete each of the following steps within 30 seconds, the learning mode will be automatically canceled. In this case, start over from step 3.

- 4 Press the button for which you want to program the new function. “LEARN” appears in the display window on the remote control.

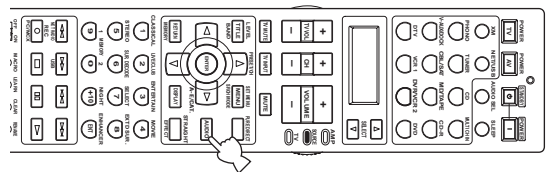

(U.S.A. model)

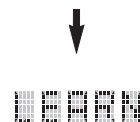

**5 Press and hold the button you want to program on the other remote control until “OK” appears in the display window on the remote control.**

“NG” appears in the display window on the remote control if learning was unsuccessful. In this case, start over from step 4.

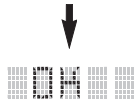
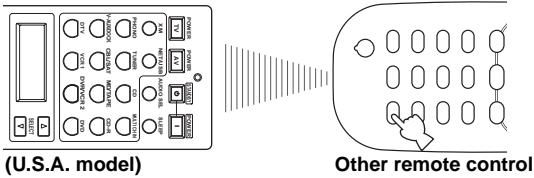

- If you want to program another function, repeat steps 4 and 5.
- If you continuously want to program another function for another component, press SELECT  $\Delta$  /  $\nabla$  to select the component, and then repeat steps 4 and 5.

**6 Press LEARN again to exit the learning mode.**



**Notes**

- “ERROR” appears in the display window on the remote control if you press a button not indicated in the respective step, or when you press more than one button simultaneously.
- This remote control can learn approximately 200 functions. However, depending on the signals learned, “FULL” may appear in the display before you program 200 functions. In this case, clear unnecessary programmed functions to make room for further learning.
- Learning may not be possible in the following cases:
  - when the batteries in the remote control for this unit or other components are weak.
  - when the distance between the two remote controls is too great or too small.
  - when the remote control infrared windows are not facing each other at the appropriate angle.
  - when the remote control is exposed to direct sunlight.
  - when the function to be programmed is continuous or uncommon.

**Changing source names in the display window**

You can change the name of the input source that appears in the display window on the remote control if you want to use a different name than the factory preset. This feature is useful when you have set an input area to control a different component.

**1 Set the operation mode selector to AMP or SOURCE and then press an input selector button to select the input area you want to rename.**

The name of the selected input area appears in the display window.

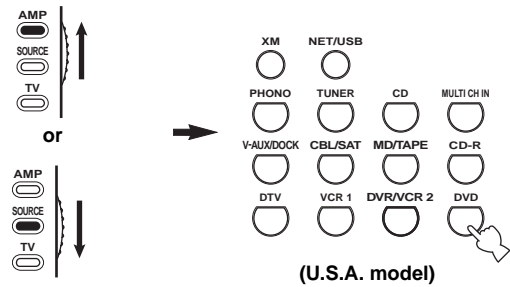

(U.S.A. model)

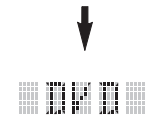

**2 Press RENAME using a ballpoint pen or similar object.**



**Note**

If you do not complete each of the following steps within 30 seconds, the renaming mode will be automatically canceled. In this case, start over from 2.

**3 Press  $\Delta$  /  $\nabla$  to select and enter a character.**

Pressing  $\nabla$  changes the character as follows:  
 A to Z, 1 to 9, 0, + (plus), - (hyphen), ; (semicolon), / (slash), and space.  
 Pressing  $\Delta$  changes the characters in reverse order.

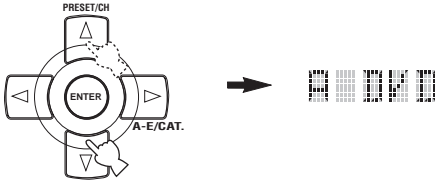

**4 Press  $\triangleright$  to move the cursor to the next position.**

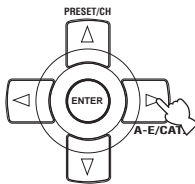

Press  $\triangleleft$  to move the cursor to the previous position.

**5 Press ENTER to set the new name.**

“OK” appears in the display window on the remote control if renaming was successful.  
 “NG” appears in the display window on the remote control if renaming was unsuccessful. In this case, start over from step 3.



If you continuously want to rename another input area, press the input selector button, or press SELECT  $\Delta$  /  $\nabla$  repeatedly to select the component, then repeat steps 3 through 5.

**6 Press RENAME again to exit the renaming mode.**



**Note**

“ERROR” appears in the display window on the remote control if you press a button not indicated in the respective step, or when you press more than one button simultaneously.



This feature is useful when you change the input or output assignment for digital jacks and component video input jacks. Refer to “Rename” on page 95.

**Macro programming features**

The macro programming feature makes it possible to perform a series of operations with the press of a single button. For example, when you want to play a CD, normally you would turn on the components, select the CD input, and press the play button to start playback. The macro programming feature lets you perform all of these operations simply by pressing the CD macro button. The buttons listed as macro buttons below are factory set with macro programs. You can also program your own macros (see page 126).

**MACRO operations**

**Macro buttons**

(U.S.A. model)

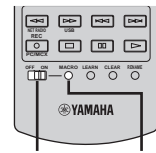
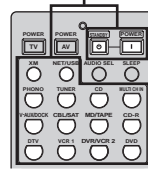

MACRO ON/OFF

MACRO

**1 Set the MACRO ON/OFF selector to ON.**

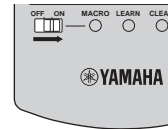

**2 Press the desired macro button.**

**3 Set the MACRO ON/OFF selector to OFF when you finish to using the macro programming operation.**

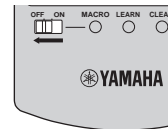

**Notes**

- While the remote control is running a macro program, it does not accept any other operation until it has completed running the program (the transmission indicator stops flashing).
- Continue to aim the remote control at the component the macro is operating until the macro operation is complete.



■ Default macro functions

Pressing macro button



To automatically transmit these signals in order		
First	Second	Third
	—	—
(*1)	(*2)	—
		—
		—
(*1)		—
	(*3)	—
		(CD area) (*4)
		—
		—
		—
		(MD/TAPE area) (*4)
		(CD-R area) (*4)
		—
		(VCR 1 area) (*4)
	(DVR/VCR 2 area) (*4)	
	(DVD area) (*4)	

\*1 You can turn on some components (including YAMAHA components) connected to this unit by connecting them to the AC OUTLETS on the rear panel of this unit. Power control may not be synchronized with this unit depending on the component. For details, refer to the operating instructions for the connected component.

\*2 When the remote control code for your TV is set up for either DTV or PHONO (see page 120), you can turn on the power of your TV without selecting an input source. The remote control code set up for DTV takes priority over the one for PHONO.

\*3 When TUNER is selected as the input source, this unit plays the last station received before the unit was set in the standby mode.

\*4 Playback can be started for any YAMAHA remote control-compatible MD recorder, CD player, CD recorder, DVD player, or DVD recorder. When using macros to operate other components, you will need to program the play button on the input area of that component (see page 122) or set a remote control code (see page 120).

## ■ Programming macro operations

You can program your own macro and use the macro programming feature to transmit several remote control commands in sequence at the press of a button. Be sure to set up remote control codes or perform learning operations before programming the macro.

### Notes

- The default macro is not cleared when a new macro is programmed for a button. The default macro can be used again when the programmed macro is cleared.
- It is not possible to add a new signal (macro step) to the default macro. Programming a macro changes all macro contents.
- We do not recommend programming continuous operations such as volume control in a macro.

### 1 Set the operation mode selector to AMP or SOURCE and then press MACRO using a ballpoint pen or similar object.

“MCR ?” appears in the display window on the remote control.

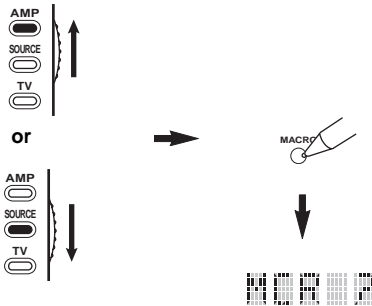

### Note

If you do not complete each of the following steps within 30 seconds, the macro programming mode will be automatically canceled. In this case, start over from step 1.

### 2 Press the macro button you want to use to operate the macro.

The macro button name (ex. “M;DVD”) and the selected component name (ex. “DVD”) appear alternately in the display window on the remote control.

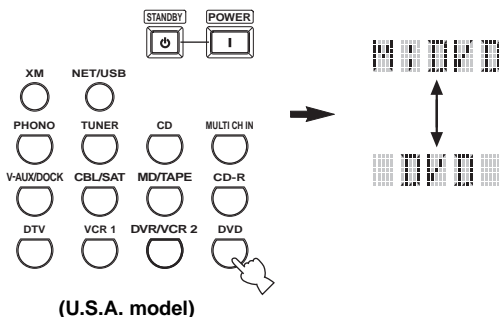

### Note

“AGAIN” appears in the display window if you press a button other than a macro button.

### 3 Press the buttons for the functions you want to include in the macro operation in sequence.

You can set up to 10 steps (10 functions). After you have set 10 steps, “FULL” appears and the remote control automatically exits the macro mode. The following example is for programming the following procedure:

Step 1 (“MCR 1”): Press DVD.

Step 2 (“MCR 2”): Press AV POWER.

Step 3 (“MCR 3”): Press SLEEP.

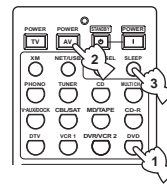

MCR 2: AV POWER

MCR 3: SLEEP

MCR 1: DVD

(U.S.A. model)

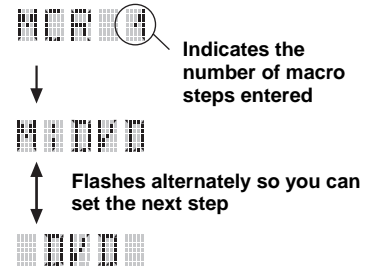

### Note

To change the selected input area, press SELECT  $\Delta$  /  $\nabla$ .

Pressing the input selector buttons will program a macro step, whereas SELECT  $\Delta$  /  $\nabla$  only changes the selected input area.

### 4 Press MACRO again using a ballpoint pen or similar object when the operation sequence you want to program is complete.

### Note

“ERROR” appears in the display window if you press more than one button simultaneously.

## Clearing configurations

You can clear all changes made in each function set, such as learned functions, macros, renamed input area names and setup remote control ID.

### Clearing function sets

#### 1 Set the operation mode selector to AMP or SOURCE and then press CLEAR by using a ballpoint pen or similar object.

“CLEAR” appears in the display window.

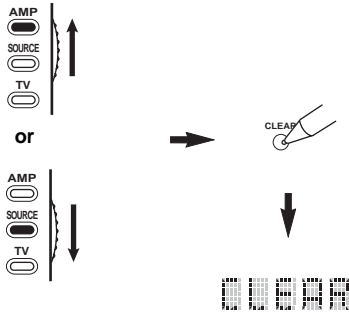

#### Note

If you do not complete each of the following steps within 30 seconds, the clearing mode will be automatically canceled. In this case, start over from step 1.

#### 2 Press $\Delta$ / $\nabla$ to select the clear mode.

- L;CD (etc.) (L; Name of an input area)  
Clears all learned functions in the respective input area. The name of a component is shown after a semicolon (;). Press an input selector button to select the input area.
- L;AMP  
Clears all learned functions for controlling the amplifier functions of this unit.
- L;ALL  
Clears all learned functions.
- M;ALL  
Clears all programmed macros.
- RNAME  
Clears all renamed source names.
- FCTRY  
Clears all remote functions and returns the remote to the factory settings.

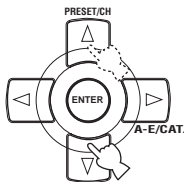

#### 3 Press and hold CLEAR again for about 3 seconds.

“WAIT” appears in the display window. If clearing was successful, “C;OK” appears in the display window on the remote control.



Once you have cleared a learned function for a button, the button reverts to the factory setting (or to the manufacturer setting, if you have set remote control codes).

#### Notes

- “L;ALL” and “FCTRY” may take about 30 seconds to complete.
- “C;NG” appears in the display window if clearing was unsuccessful. In this case start over from step 2.
- “ERROR” appears in the display window if you press a button not indicated in the respective step, or if you press more than one button simultaneously.

**■ Clearing a learned function**

You can clear the function learned for a certain button in each control area.

**1 Set the operation mode selector to AMP or SOURCE and then press an input selector button to select the input area containing the function you want to clear.**

The selected component name appears in the display window.

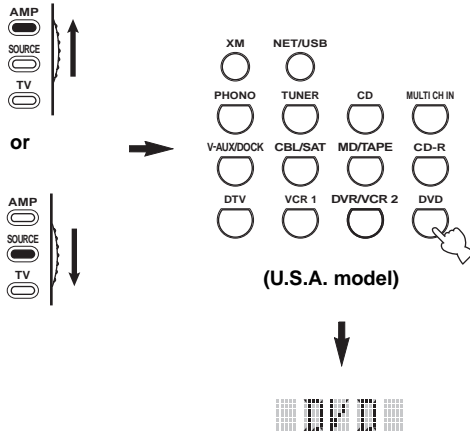

**2 Press LEARN using a ballpoint pen or similar object.**

“LEARN” and the selected component name (ex. “DVD”) appear alternately in the display window.

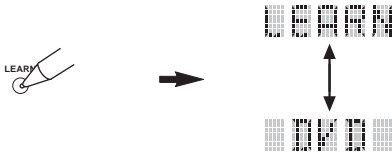

**Notes**

- Do not press and hold LEARN. If you hold it down for more than 3 seconds, the remote control enters the remote control code setting mode.
- If you do not complete each of the following steps within 30 seconds, the learning mode will be automatically canceled. In this case, start over from step 2.

**3 Press and hold CLEAR using a ballpoint pen or similar object and then press the button you want to clear for about 3 seconds.**

“C;OK” appears in the display window if clearing was successful. Once “C;OK” appears in the display window on the remote control, release the ballpoint pen or similar object used to press CLEAR to exit the clearing mode. The remote control returns to the learning mode.

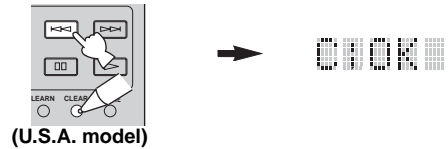

- If you continuously want to clear another function, repeat step 4.
- If you continuously want to clear another function for another component, press SELECT  $\Delta$  /  $\nabla$  to select the input area, then repeat step 4.
- Once you clear a learned function, the button reverts to the factory setting (or to the manufacturer setting if you have set remote control codes).

**4 Press LEARN again to exit.**

**Notes**

- “C;NG” appears in the display window on the remote control if clearing was unsuccessful. In this case, start over from step 2.
- “ERROR” appears in the display window if you press more than one button simultaneously.

## ■ Clearing a macro function

You can clear the function programmed for a certain macro button.

### 1 Set the operation mode selector to AMP or SOURCE and then press MACRO using a ballpoint pen or similar object.

“MCR ?” appears in the display window on the remote control.

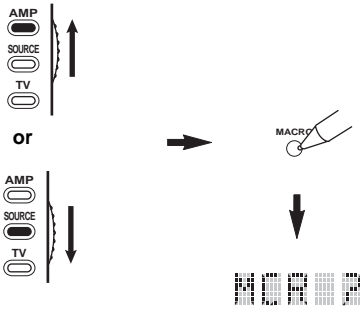

#### Note

If you do not complete each of the following steps within 30 seconds, the macro programming mode will be automatically canceled. In this case, start over from step 1.

### 2 Press and hold CLEAR using a ballpoint pen or similar object, then press the macro button you want to clear for about 3 seconds.

“C;OK” appears in the display window on the remote control if clearing was successful.

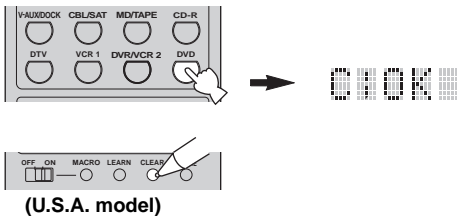

- If you continuously want to clear another function, repeat step 2.
- Once you clear a programmed function, the button reverts to the factory setting (or to the manufacturer setting if you have set remote control codes).

### 3 Press MACRO again to exit the macro programming mode.

#### Notes

- “C;NG” appears in the display window on the remote control if clearing was unsuccessful. In this case, start over from step 2.
- “ERROR” appears in the display window on the remote control if you press more than one button simultaneously.

# USING MULTI-ZONE CONFIGURATION

This unit allows you to configure a multi-room audio/video system. The multi-zone configuration feature enables you to set this unit to reproduce separate input sources in the main room, second room (Zone 2) and third room (Zone 3). You can control this unit from the second or third room using the supplied remote control.

Only analog signals are sent to the second and third rooms. Any source you want to listen to in the second or third room must be connected using the analog (AUDIO L/R) input jacks on this unit.

## Connecting the Zone 2 and Zone 3 components

You need the following additional equipment to use the multi-room functions of this unit:

- An infrared signal receiver in the second and/or third room.
- An infrared emitter in the main room. This emitter transmits the infrared signals from the remote control in the second and/or third room to the main room (to a CD player or DVD player, for example).
- An amplifier and speakers for the second and/or third room.
- A video monitor for the second room



- You do not need an extra amplifier and speakers for the second and/or third room if you want to use the internal amplifiers of this unit.
- Since there are many possible ways to connect and use this unit in a multi-room configuration, we recommend that you consult with your nearest authorized YAMAHA dealer or service center for the Zone 2 and Zone 3 connections that best meet your requirements.

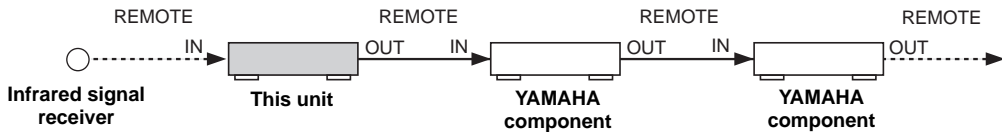

### ■ Using external amplifiers

To use an external amplifier in Zone 2 or Zone 3, connect the external amplifier to ZONE OUT terminals and select "EXT" in "Zone2 Amplifier" or "Zone3 Amplifier" (see page 113).

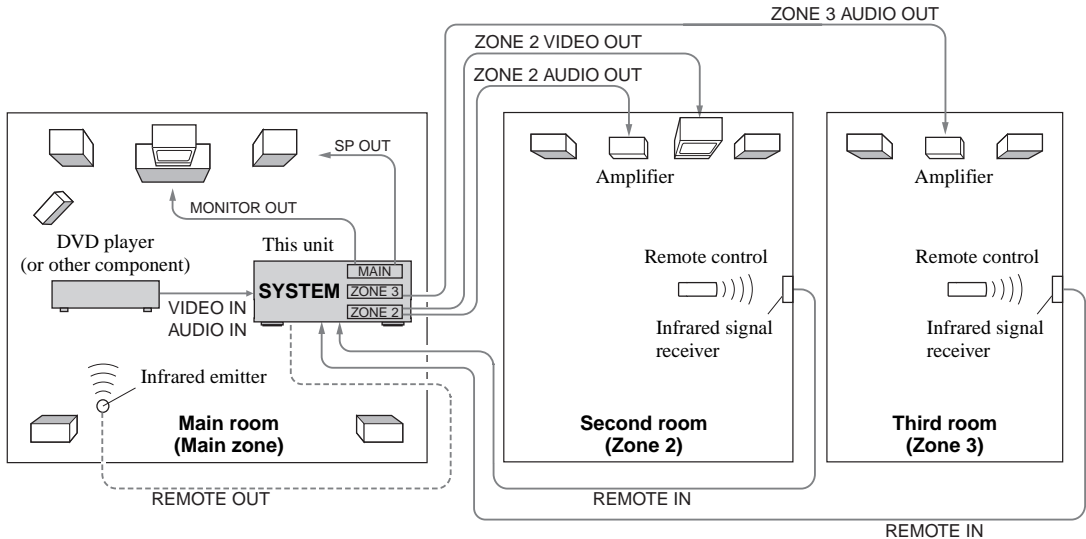

### Notes

- Adjust the Zone 2/Zone 3 volume by using the amplifier in the second/third room when "Zone2 Volume" or "Zone3 Volume" are set to "Fixed" (see page 113).
- To avoid unexpected noise, DO NOT use the Zone 2/Zone 3 feature with CDs encoded in DTS.

■ Using the internal amplifiers of this unit

**IMPORTANT SAFETY NOTICE**

The SP1 or SP2 speaker terminals of this Receiver should not be connected to a Passive Loudspeaker Selector Box or more than one loudspeaker per channel. Connection to a Passive Loudspeaker Selector Box or multiple speakers per channel could create an abnormally low impedance load resulting in amplifier damage. See this owner's manual for correct usage. Compliance with minimum speaker impedance information for all channels must be maintained at all times. This information is found on the back panel of your Receiver.

**If you want to use one internal amplifier (SP1 or SP2) of this unit**

Connect the Zone 2 or Zone 3 speakers directly to the SP1 or SP2 speaker terminals and select either "INT:[SP1]" or "INT:[SP2]" for "Zone2 Amplifier" or "Zone3 Amplifier" (see page 113).

**If you want to use two internal amplifiers (both SP1 and SP2) of this unit**

Connect the Zone 2 or Zone 3 speakers directly to the SP1 and SP2 speaker terminals and select "Both" for "Zone2 Amplifier" or "Zone3 Amplifier" (see page 113).

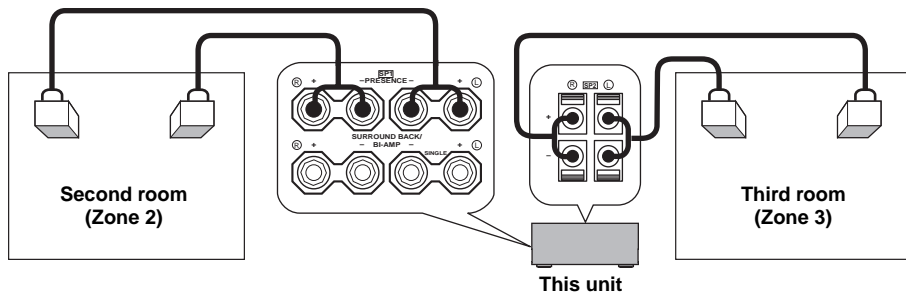

**Controlling Zone 2 or Zone 3**

You can select the zone you want to control by using the control buttons on the front panel or on the remote control.

■ Selecting Zone 2 or Zone 3

Front panel operations

- 1 Press ZONE 2 ON/OFF or ZONE 3 ON/OFF on the front panel to individually turn on or off Zone 2 or Zone 3.



Once MASTER ON/OFF on the front panel is pressed inward to the ON position, you can also press POWER and STANDBY on the remote control to turn on the main zone, Zone 2 and Zone 3.

- 2 Press ZONE CONTROLS on the front panel repeatedly to select the zone you want to control.



Each time you press ZONE CONTROLS, the front panel display changes as shown below, and the indicator for the currently selected zone flashes for approximately 5 seconds. However, no indicator flashes when the main zone is selected.

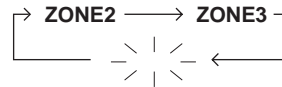

No indicator flashes when the main zone is selected.

**ZONE2**

Controls the Zone 2 amplifier or tuner functions.

**ZONE3**

Controls the Zone 3 amplifier or tuner functions.



- You must complete this step within 5 seconds while the selected zone flashes in the front panel display. Otherwise, the currently selected zone mode is automatically canceled. In this case, press ZONE CONTROLS again.
- The initial setting is ZONE2 when both Zone 2 and Zone 3 are turned on.

**3** Refer to “Selecting the input source of Zone 2 or Zone 3”, “Adjusting the volume level of Zone 2 or Zone 3”, “Adjusting the balance of the speaker level in Zone 2 or Zone 3” or “Adjusting the tonal quality of Zone 2 or Zone 3” on page 133 to perform further operations.

**Remote control operations**

**1** Set the operation mode selector to AMP and then press SELECT  $\Delta$  repeatedly to select the zone you want to control.

“ZONE 2” or “ZONE 3” is displayed in the display window on the remote control.

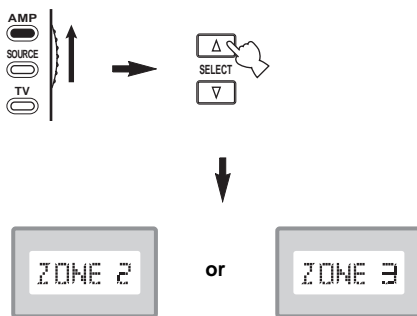

**2** Refer to “Selecting the input source of Zone 2 or Zone 3”, “Adjusting the volume level of Zone 2 or Zone 3”, “Adjusting the balance of the speaker level in Zone 2 or Zone 3” or “Adjusting the tonal quality of Zone 2 or Zone 3” on page 133 to perform further operations.

**3** Press SELECT  $\Delta$  /  $\nabla$  to exit from the Zone 2/Zone 3 mode.

**Turning on or off Zone 2 and/or Zone 3 using the remote control**

POWER and STANDBY on the remote control work differently depending on the selected zone that appears in the display window on the remote control.

- When the main zone, Zone 2 or Zone 3 mode is selected (see page 132), you can turn on the main zone, Zone 2 or Zone 3 or set them to the standby mode individually.
- When the all mode is selected, pressing POWER turns on the main zone, Zone 2 and Zone 3 simultaneously and pressing STANDBY sets them to the standby mode simultaneously.

Control mode	Display window	POWER and STANDBY
Main zone mode	Name of the selected input area	Turns on the main zone only or sets it to the standby mode.
Zone 2 mode	“ZONE 2” or “2;name of the selected input area”	Turns on Zone 2 or sets it to the standby mode.
Zone 3 mode	“ZONE 3” or “3;name of the selected input area”	Turns on Zone 3 or sets it to the standby mode.
All mode	“ALL”	POWER: turns on the main zone, Zone 2 and Zone 3. STANDBY: sets the main zone, Zone 2 and Zone 3 to the standby mode.

**Notes**

- When the remote control is in the main zone mode, “MAIN” appears for a few seconds when POWER or STANDBY is pressed.
- “ALL” appears in the display window on the remote control only when SELECT  $\nabla$  is pressed.

**Selecting the input source of Zone 2 or Zone 3**

Rotate the INPUT selector on the front panel (or set the operation mode selector to AMP and then press one of the input selector buttons on the remote control) to select the input source of the selected zone.

If the remote control is used to select the input source, “2: name of the selected input area” or “3: name of the selected input area” is displayed in the display window on the remote control when Zone 2 or Zone 3 is selected respectively.



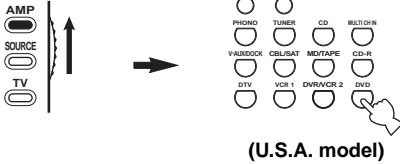
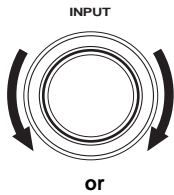

(U.S.A. model)

- Select TUNER as the input source to use the TUNER features in the selected zone. For details about the TUNER operations, see “FM/AM TUNING” on page 56.
- Select XM as the input source to use the XM Satellite Radio features in the selected zone. For details about the XM Satellite Radio operations, see “XM SATELLITE RADIO TUNING” on page 63.

**Note**

The selected input source is shared across all zones.

- You must complete this step within 5 seconds while the selected zone flashes in the front panel display. Otherwise, the currently selected zone mode is automatically canceled. In this case, press ZONE CONTROLS on the front panel again.
- When a video monitor is connected to one of the ZONE VIDEO jacks, you can display the control information of Zone 2 or Zone 3 and XM Satellite Radio information on the video monitor screen. Set “Zone OSD” to “Zone2&Zone3” or “Zone2” (see page 112).

■ **Adjusting the volume level of Zone 2 or Zone 3**

Rotate **VOLUME** on the front panel (or press **VOLUME +/-** on the remote control) to adjust the volume level of the selected zone.

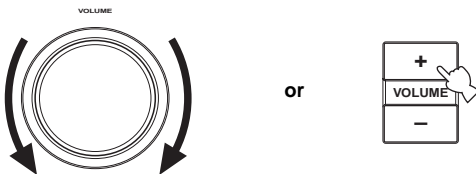

- Press MUTE on the remote control to mute the sound output to the selected zone.

**Note**

When you use the external amplifiers in Zone 2 or Zone 3, VOLUME +/- can be used only when “Zone2 Volume” or “Zone3 Volume” is set to “Variable” in “Zone2 Set” or “Zone3 Set” (see page 113).

■ **Adjusting the balance of the speaker level in Zone 2 or Zone 3**

Press **TONE CONTROL** repeatedly to select “BALANCE” and then rotate **PROGRAM** on the front panel to adjust the balance of the front left and right speaker level of the selected zone.



■ **Adjusting the tonal quality of Zone 2 or Zone 3**

Set the operation mode selector to **AMP** and then press **CH +/-** on the remote control to adjust the high-frequency response (**TREBLE**) or **TV VOL +/-** to adjust the low-frequency response (**BASS**) respectively.

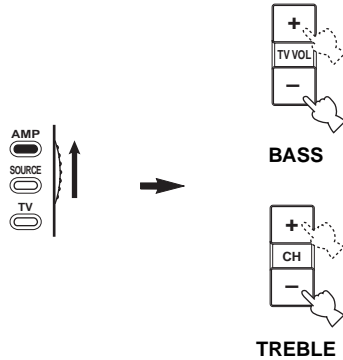

- You can also adjust the tonal quality of Zone 2 or Zone 3 by using TONE CONTROL on the front panel. For details, see “Adjusting the tonal quality” on page 52.

**Note**

Check that “ZONE 2” or “ZONE 3” is displayed in the display window of the remote control before you adjust the tonal quality of the corresponding zone (see page 132).

# ADVANCED SETUP

This unit has additional menus that are displayed in the front panel display. The advanced setup menu offers additional operations to adjust and customize the way this unit operates. Change the initial settings (indicated in bold under each parameter) to reflect the needs of your listening environment.

## Notes

- The settings you make are reflected next time you press MASTER ON/OFF inward to the ON position to turn on this unit (see page 34).
- Only MASTER ON/OFF, STRAIGHT and the PROGRAM selector are effective while you are using the advanced setup menu.
- All the other operations cannot be made while you are using the advanced setup menu.
- The advanced setup menu is only available in the front panel display.

## Using ADVANCED SETUP

(U.S.A. model)

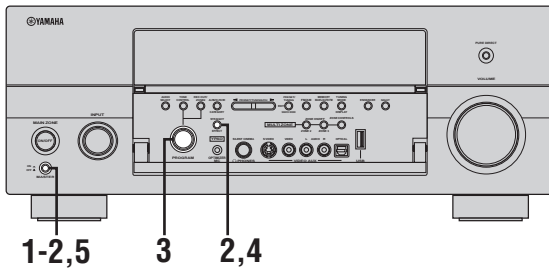

- 1 Press MASTER ON/OFF on the front panel to release it outward to the OFF position to turn off this unit.**



- 2 Press and hold STRAIGHT on the front panel and then press MASTER ON/OFF inward to the ON position to turn on this unit.**

This unit turns on, and the advanced setup menu appears in the front panel display.



- 3 Rotate the PROGRAM selector on the front panel to select the parameter you want to adjust.**

The name of the selected parameter appears in the front panel display.

See page 135 for a complete list of available parameters.



Currently selected parameter

Currently selected parameter setting

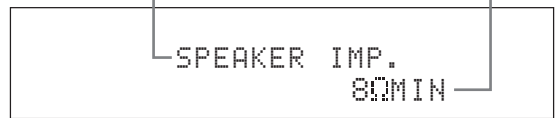

- 4 Press STRAIGHT on the front panel repeatedly to change the selected parameter setting.**



- 5 Press MASTER ON/OFF on the front panel to release it outward to the OFF position to save the new setting and turn off this unit.**



The settings you made are reflected next time you turn on this unit.

**Speaker impedance** SPEAKER IMP.

Use this feature to set the speaker impedance of this unit so that it matches that of your speakers.

Choices: **8ΩMIN**, **6ΩMIN**

- Select “8ΩMIN” to set the speaker impedance to 8 Ω .
- Select “6ΩMIN” to set the speaker impedance to 6 Ω .

SPEAKER IMP.	Speaker	Impedance level
8ΩMIN	Front	The impedance of each speaker must be 8 Ω or higher.
	Center	The impedance of each speaker must be 8 Ω or higher.
	Surround	
	Surround back	
6ΩMIN	Front	The impedance of each speaker must be 4 Ω or higher.
	Center	The impedance of each speaker must be 6 Ω or higher.
	Surround	
	Surround back	

**User presets** USER PRESET

Use this feature to reset all the parameters of this unit to the initial factory settings (see page 149).

Choices: **CANCEL**, **RESET**

- Select “CANCEL” not to reset any parameters of this unit.
- Select “RESET” to reset the parameters of this unit.

**Notes**

- This setting completely resets all the parameters of this unit. However, the advanced setup menu parameters will not be initialized.
- The initial factory settings are activated next time you turn on this unit.

**Remote sensor** REMOTE SENSOR

Use this feature to activate or deactivate the signal-receiving capability of the remote control sensor on the front panel of this unit.

Choices: **ON**, **OFF**

- Select “ON” if you want to activate the signal-receiving capability of the remote control sensor.
- Select “OFF” if you want to deactivate the signal-receiving capability of the remote control sensor.

**Note**

We recommend setting the parameter to “ON” in most cases.

**Wake on RS-232C access**

WAKE ON RS232C

Use this feature to set this unit to transmit data via the RS-232C interface when this unit is in the standby mode.

Choices: **YES**, **NO**

Initial setting:

[U.S.A. and Canada models]: **YES**

[Other models]: **NO**

- Select “YES” to set this unit to transmit data via the RS-232C interface.
- Select “NO” to set this unit not to transmit data via the RS-232C interface.

**Remote control AMP ID**

RC AMP ID

Use this feature to set the AMP ID of this unit for remote control recognition (see page 121).

Choices: **ID1**, **ID2**

- Select “ID1” when the remote control AMP ID library code is set to “2001”.
- Select “ID2” when the remote control AMP ID library code is set to “2002”.

**Note**

You need to set the corresponding remote control AMP library code for the remote control (see page 121).

**Remote control TUNER ID**

RC TUNER ID

Use this feature to set the TUNER ID of this unit for remote control recognition (see page 138).

Choices: **ID1**, **ID2**

- Select “ID1” when the remote control TUNER ID library code is set to “2602”.
- Select “ID2” when the remote control TUNER ID library code is set to “2603”.

**Note**

You need to set the corresponding remote control TUNER library code for the remote control (see page 138).

**Remote control XM ID** RC XM ID  
**(U.S.A. and Canada models only)**

Use this feature to set the XM ID of this unit for remote control recognition (see page 138).

Choices: **ID1**, **ID2**

- Select “ID1” when the remote control XM ID library code is set to “2604”.
- Select “ID2” when the remote control XM ID library code is set to “2605”.

**Note**

You need to set the corresponding remote control XM library code for the remote control (see page 138).

### ■ Tuner frequency step TUNER FRQ STEP (Asia and General models only)

Use this feature to set the tuner frequency step according to the frequency spacing in your area.

Choices: **AM10/FM100**, AM9/FM50

- Select “AM10/FM100” for North, Central and South America.
- Select “AM9/FM50” for all other areas.

### ■ Bi-AMP BI-AMP

Use to activate or deactivate the bi-AMP function.

Choices: ON, **OFF**

- Select “ON” if you want to activate the bi-AMP function.
- Select “OFF” if you want to deactivate the bi-AMP function.

#### Note

When “BI-AMP” is set to “ON”, the SURROUND BACK terminals cannot be used to connect surround back speakers in that the SURROUND BACK terminals are already used for the bi-AMP connection (see page 19).

### ■ Video reset VIDEO RESET

Use to initialize the parameter settings for “Video” in “Manual Setup” (see page 101).

Choices: YES, **CANCEL**

#### Note

The parameter setting for “Short Message” or “On Screen” is not initialized (see page 101).

### ■ Network reset NETWORK RESET

Use this feature to reset the network settings of this unit (see page 109) to the initial factory settings.

Choices: **CANCEL**, RESET

- Select “CANCEL” not to reset any network settings of this unit.
- Select “RESET” to reset the network settings of this unit.

#### Notes

- The initial factory settings are activated next time you turn on this unit.
- When the network settings are reset, “DHCP” in “NET/USB” is automatically set to “On” (see page 109) and the registered client ID of this unit on your YAMAHA MCX-2000 is cleared (see page 80).

### ■ TV format TV FORMAT

Use this feature to set the color encoding format of your television.

Choices: NTSC, PAL

Initial setting:

[U.S.A., Canada, General and Korea models]: NTSC

[Other models]: PAL

#### Note

This parameter setting only affects the video monitor connected to the MONITOR OUT jacks and does not affect the Zone 2 video monitor connected to the ZONE 2 VIDEO jacks.

### ■ Monitor check for HDMI up-scaling

#### MONITOR CHECK

Use this feature to activate or deactivate the monitor check function of this unit. When this parameter is set to “YES”, this unit receives the information of the available video signal resolutions from the video monitor connected via HDMI (see page 102).

Choices: **YES**, SKIP

### ■ GUI language GUI LANGUAGE

Use this feature to select the language of your choice that appears in the GUI (graphical user interface) menu of this unit.

Choices: **ENGLISH** (English), JAPANESE (Japanese), FRENCH (French), GERMAN (German), SPANISH (Spanish), RUSSIAN (Russian)

## Setting remote control ID

When using multiple YAMAHA receivers/amplifiers, you may be able to operate the other components simultaneously with the default code setting. In this case, set one of the alternative codes to operate this unit separately.

### Setting remote control AMP ID

**1 Set the operation mode selector to AMP or SOURCE.**

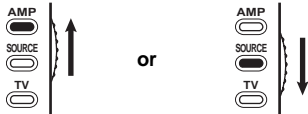

**2 Press and hold LEARN for about 3 seconds using a ballpoint pen or similar object and then press </> repeatedly until "L;AMP" appears in the display window on the remote control.**

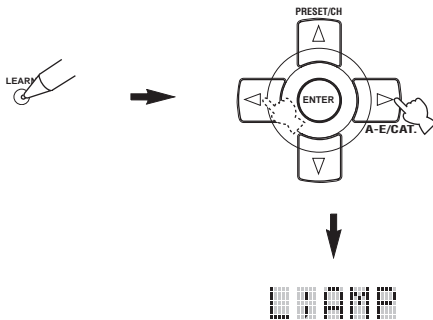

#### Notes

- Be sure to press and hold LEARN for at least 3 seconds, otherwise the learning process will start.
- If you do not complete each of the following steps within 30 seconds, the setting mode will be automatically canceled. In this case, start over from step 1.

**3 Press ENTER.**

The four-digit code set for the selected input area appears in the display window on the remote control.

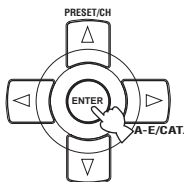

**4 Press the numeric buttons to enter the four-digit remote control code for the input area you want to use.**

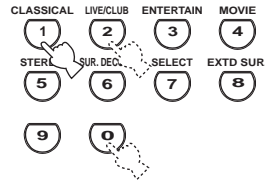

#### Remote control AMP codes

Select one of the following codes to set the remote control AMP code for the input area you want to use.

AMP library code (remote control setting)	Function	Remote control AMP ID
2001 (initial setting)	To operate this unit using the default code.	ID1 (initial setting)
2002	To operate this unit using an alternative code.	ID2

#### Note

You need to set the corresponding remote control AMP ID (see page 135).

**5 Press ENTER to set the number.**

"OK" appears in the display window if setting was successful.

"NG" appears in the display window if the setting was unsuccessful. In this case, start over from step 1.

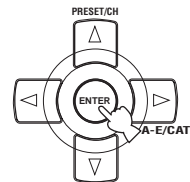

**6 Press LEARN again to exit from the setup mode.**



■ Setting remote control tuner ID or XM ID

1 Set the operation mode selector to AMP or SOURCE and then press TUNER or XM on the remote control to select the tuner or XM to change the remote control ID.

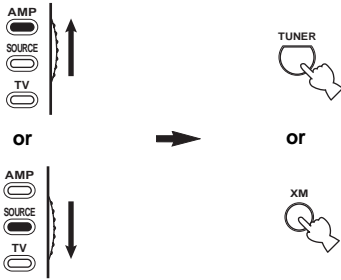

2 Press and hold LEARN for about 3 seconds using a ballpoint pen or similar object and then press </> repeatedly until "L;TUN" and "TUNER", or "L;TUN" and "XM" alternately appear in the display window on the remote control.

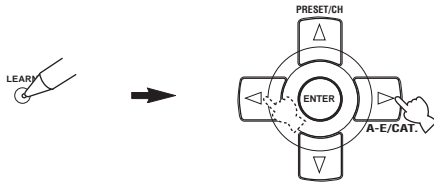

**Notes**

- Be sure to press and hold LEARN for at least 3 seconds, otherwise the learning process will start.
- If you do not complete each of the following steps within 30 seconds, the setting mode will be automatically canceled. In this case, start over from step 1.

3 Press ENTER.

The four-digit code set for the selected input area appears in the display window on the remote control.

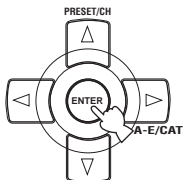

4 Press the numeric buttons to enter the four-digit remote control code for the input area you want to use.

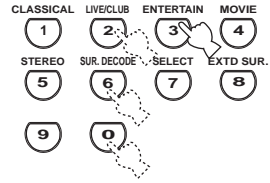

**Remote control tuner codes**

Select one of the following codes to set the remote control tuner code for the input area you want to use.

Tuner library code (remote control setting)	Function	Remote control tuner ID
2602 (initial setting)	To operate this unit using the default code.	ID1 (initial setting)
2603	To operate this unit using an alternative code.	ID2

**Remote control XM codes**

Select one of the following codes to set the remote control XM code for the input area you want to use.

XM library code (remote control setting)	Function	Remote control XM ID
2604 (initial setting)	To operate this unit using the default code.	ID1 (initial setting)
2605	To operate this unit using an alternative code.	ID2

**Note**

You need to set the corresponding remote control tuner ID or XM ID (see page 135).

5 Press ENTER to set the number.

"OK" appears in the display window if setting was successful.

"NG" appears in the display window if the setting was unsuccessful. In this case, start over from step 1.

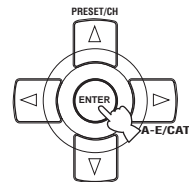

6 Press LEARN again to exit from the setup mode.



# TROUBLESHOOTING

Refer to the table below when this unit does not function properly. If the problem you are experiencing is not listed below or if the instruction below does not help, turn off this unit, disconnect the power cable, and contact the nearest authorized YAMAHA dealer or service center.

## ■ General

Problem	Cause	Remedy	See page
<b>This unit fails to turn on or enters the standby mode soon after the power is turned on.</b>	The power cable is not connected or the plug is not completely inserted.	Connect the power cable firmly.	—
	The speaker impedance setting is incorrect.	Set the speaker impedance to match your speakers.	33
	The protection circuitry has been activated.	Make sure that all speaker wire connections on this unit and on all speakers are secure and that the wire for each connection does not touch anything other than its respective connection.	16
	This unit has been exposed to a strong external electric shock (such as lightning or strong static electricity).	Set this unit to the standby mode, disconnect the power cable, plug it back in after 30 seconds and then use it normally.	—
<b>No sound.</b>	Incorrect input or output cable connections.	Connect the cables properly. If the problem persists, the cables may be defective.	23-29
	The optimizer microphone is connected.	Disconnect the optimizer microphone.	38
	Audio input jack select is set to “HDMI”, “COAX/OPT” or “ANALOG”.	Set Audio input jack select to “AUTO”.	42
	Audio input jack select is set to “ANALOG” while playing a source encoded in Dolby Digital or DTS.	Set Audio input jack select to “AUTO” or “COAX/OPT”.	42
	No appropriate input source has been selected.	Select an appropriate input source with the INPUT selector on the front panel (or the input selector buttons on the remote control).	40, 43
	Speaker connections are not secure.	Secure the connections.	16
	The volume is turned down.	Turn up the volume.	—
	The sound is muted.	Press MUTE or VOLUME +/- on the remote control to resume audio output and then adjust the volume.	43
	Signals this unit cannot reproduce are being input from a source component, such as a CD-ROM.	Play a source whose signals can be reproduced by this unit.	—
	The HDMI components connected to this unit do not support the HDCP copy protection standards.	Connect HDMI components that support the HDCP copy protection standards.	21
	“Support Audio” is set to “Other” and “HDMI” audio signals are not being played back on this unit.	Set “Support Audio” to “RX-V2700” in “Option”.	115

Problem	Cause	Remedy	See page
<b>No picture.</b>	The output and input for the picture are connected to different types of video jacks.	Set "Conversion" to "On" or connect your source components in the same way as you connect your video monitor to this unit.	102
	Non-standard video signals are input.		
<b>Short message displays do not appear in the video monitor.</b>	"Short Message" is set to "OFF".	Set "Short Message" to "On".	103
	"Wall Paper" is set to "None".	Set "Wall Paper" to "Yes" or "Gray".	104
	"Conversion" is set to "Off".	Set "Conversion" to "On".	102
	The signals input at the HDMI IN1, HDMI IN2 or HDMI IN3 jack are being output at the HDMI OUT jack. Video signals in the progressive format or HDTV video signals are being input.		
<b>The sound suddenly goes off.</b>	The protection circuitry has been activated because of a short circuit, etc.	Check that the speaker impedance setting is correct. Check that the speaker wires are not touching each other and then turn this unit back on.	33, 135 —
	The sleep timer has turned off this unit.	Turn on this unit, and play the source again.	—
	The sound is muted.	Press MUTE or VOLUME +/- on the remote control to resume audio output.	43
<b>Sound is heard from the speaker on one side only.</b>	Incorrect cable connections.	Connect the cables properly. If the problem persists, the cables may be defective.	16
	Incorrect settings in "Speaker Level".	Adjust the "Speaker Level" settings.	109
<b>Only the center speaker outputs substantial sound.</b>	When playing a monaural source with a CINEMA DSP program, the source signal is directed to the center channel, and the front and surround speakers output effect sounds.		
<b>No sound is heard from the center speaker.</b>	"Center" in "Speaker Set" is set to "None".	Set "Center" to "Small" or "Large".	105
	One of the HiFi DSP programs (except for "7ch Stereo") has been selected.	Try another sound field program.	47
<b>No sound is heard from the presence speakers.</b>	The sound field programs are turned off.	Press STRAIGHT to turn them on.	51
	You are using a source or program combination that does not output sound from all channels.	Try another sound field program.	40
<b>No sound is heard from the surround speakers.</b>	"Surround" in "Speaker Set" is set to "None".	Set "Surround" to "Small" or "Large".	106
	This unit is in the "STRAIGHT" mode and a monaural source is being played back.	Press STRAIGHT on the front panel so that "STRAIGHT" disappears from the front panel display.	51
<b>No sound is heard from the subwoofer.</b>	"Bass Out" in "Speaker Set" is set to "Front" when a Dolby Digital or DTS signal is being played.	Set "Bass Out" to "SWFR" or "Both".	107
	"Bass Out" in "Speaker Set" is set to "SWFR" or "Front" when a 2-channel source is being played.	Set "Bass Out" to "Both".	107
	The source does not contain low-frequency signals.		



Problem	Cause	Remedy	See page
<b>No sound is heard from the surround back speakers.</b>	“Surround” in “Speaker Set” is set to “None” and “Surround Back” is automatically set to “None”.	Set “Surround” and “Surround Back” to a setting other than “None”.	106
	“Surround Back” in “Speaker Set” is set to “None”.	Set “Surround Back” to a setting other than “None”.	106
<b>Dolby Digital or DTS sources cannot be played. (Dolby Digital or DTS indicator in the front panel display does not light up.)</b>	The connected component is not set to output Dolby Digital or DTS digital signals.	Make an appropriate setting following the operating instructions for your component.	—
	Audio input jack select is set to “ANALOG”.	Set Audio input jack select to “AUTO”.	42
<b>A humming sound is heard.</b>	Incorrect cable connections.	Connect the audio cables firmly. If the problem persists, the cables may be defective.	—
	No connection from the turntable to the GND terminal.	Connect the grounding cable of your turntable to the GND terminal of this unit.	26
<b>The volume level is low while a record is being played.</b>	The record is being played on a turntable with an MC cartridge.	Connect your turntable to this unit through an MC-head amplifier.	26
<b>The volume level cannot be increased, or the sound is distorted.</b>	The component connected to the AUDIO OUT (REC) jacks of this unit is turned off.	Turn on the power of the component.	—
<b>The sound effect cannot be recorded.</b>	It is not possible to record the sound effect with a recording component.		
<b>A source cannot be recorded by a digital recording component connected to the DIGITAL OUTPUT jack.</b>	The source component is not connected to the DIGITAL INPUT jacks of this unit.	Connect the source component to the DIGITAL INPUT jacks.	24, 26
	Some components cannot record Dolby Digital or DTS sources.		
<b>A source cannot be recorded by an analog component connected to the AUDIO OUT (REC) jacks.</b>	The source component is not connected to the analog AUDIO IN jacks of this unit.	Connect the source component to the analog AUDIO IN jacks.	26
<b>The sound field parameters and some other settings of this unit cannot be changed.</b>	“Memory Guard” in “Option” is set to “On”.	Set “Memory Guard” to “Off”.	114

Problem	Cause	Remedy	See page
<b>This unit does not operate properly.</b>	The internal microcomputer has been frozen by an external electric shock (such as lightning or excessive static electricity) or by a power supply with low voltage.	Disconnect the power cable from the AC wall outlet and then plug it in again after about 30 seconds.	—
<b>“CHECK SP WIRES” appears in the front panel display.</b>	Speaker cables are short-circuited.	Make sure all speaker cables are connected correctly.	16
<b>There is noise interference from digital or radio frequency equipment.</b>	This unit is too close to the digital or high-frequency equipment.	Move this unit further away from such equipment.	—
<b>The picture is disturbed.</b>	The video source uses scrambled or encoded signals to prevent dubbing.		
<b>This unit suddenly enters the standby mode.</b>	The internal temperature becomes too high and the overheat protection circuitry has been activated.	Wait about 1 hour for this unit to cool down and then turn it back on.	—

## ■ Tuner

	Problem	Cause	Remedy	See page
FM	<b>FM stereo reception is noisy.</b>	The characteristics of FM stereo broadcasts may cause this problem when the transmitter is too far away or the antenna input is poor.	Check the antenna connections.	31
			Try using a high-quality directional FM antenna.	—
			Use the manual tuning method.	58
	<b>There is distortion, and clear reception cannot be obtained even with a good FM antenna.</b>	There is multi-path interference.	Adjust the antenna position to eliminate multi-path interference.	—
	<b>The desired station cannot be tuned into with the automatic tuning method.</b>	The signal is too weak.	Use a high-quality directional FM antenna. Use the manual tuning method.	— 58
	<b>Previously preset stations can no longer be tuned into.</b>	This unit has been disconnected for a long period.	Preset the stations again.	59, 60
AM	<b>The desired station cannot be tuned into with the automatic tuning method.</b>	The signal is weak or the antenna connections are loose.	Tighten the AM loop antenna connections and orient it for the best reception. Use the manual tuning method.	— 58
	<b>There are continuous crackling and hissing noises.</b>	Noises can result from lightning, fluorescent lamps, motors, thermostats and other electrical equipment.	Use an outdoor antenna and a ground wire. This will help somewhat, but it is difficult to eliminate all noise.	—
	<b>There are buzzing and whining noises.</b>	A TV set is being used nearby.	Move this unit away from the TV set.	—

## ■ XM Satellite Radio (U.S.A. and Canada models only)

If an operation takes longer than usual or an error occurs, one of the following messages may appear in the front panel display. In this case, read the cause and follow the corresponding remedies.

Status message	Cause	Remedy	See page
<b>CHECK ANTENNA</b>	The XM Passport and XM Passport Home Dock are not connected to the XM jack of this unit or do not work properly.	Check XM Passport and XM Passport Home Dock connections and orient for the best reception level.	63
<b>UPDATING</b>	The XM user encryption code is being updated.	Wait until the encryption code is updated.	—
<b>NO SIGNAL</b>	The signal is too weak.	Adjust the orientation of the XM Passport System for the best reception level.	63
<b>LOADING</b>	It takes longer than four seconds for audio or text data to be decoded.	Wait until the decoding process has finished.	—
<b>OFF AIR</b>	The XM Satellite Radio channel you selected is not currently broadcasting any signals.	Check the channel number again or select another XM Satellite Radio channel.	—
<b>&lt;XM&gt; ---</b>	The Channel Station ID (SID) is no longer available.		
<b>--- / ---</b>	No artist name or song title is available.		
<b>&lt;CAT&gt; ---</b>	No channels are available for the selected category.	Select another channel category by pressing CATEGORY on the front panel (or A-E/CAT. </> on the remote control) repeatedly.	69

## ■ Remote control

Problem	Cause	Remedy	See page	
<b>The remote control does not work or function properly.</b>	Wrong distance or angle.	The remote control will function within a maximum range of 6 m (20 ft) and no more than 30 degrees off-axis from the front panel.	11	
	Direct sunlight or lighting (from an inverter type of fluorescent lamp, etc.) is striking the remote control sensor of this unit.	Reposition this unit.	—	
	The batteries are weak.	Replace all batteries.	11	
	The batteries do not last long and get quickly exhausted.	Using alkaline batteries is strongly recommended.	—	
	The operation mode selector is set incorrectly.	Set the operation mode selector correctly. When operating this unit, set it to the AMP position. When operating the component selected by the input selector button, set it to the SOURCE position. When operating the TV set in the DTV or PHONO area, set it to the TV position.	—	
	The remote control code was not correctly set.	Set the remote control code correctly using "LIST OF REMOTE CONTROL CODES" at the end of this manual.		120
		Try setting another code of the same manufacturer using "LIST OF REMOTE CONTROL CODES" at the end of this manual.		120
The library code of the remote control and the remote control ID of this unit do not match.	Match the remote control ID of this unit with the corresponding remote control library code.		121, 135	

Problem	Cause	Remedy	See page
<b>The remote control does not work or function properly.</b>	Even if the remote control code is correctly set, there are some models that do not respond to the remote control.	Program the necessary functions independently into the programmable buttons using the Learn feature.	122
<b>The remote control does not learn new functions.</b>	The batteries of this remote control and/or the other remote control are too weak.	Replace the batteries.	11
	The distance between the two remote controls is too much or too little.	Place the remote controls at the proper distance.	122
	The signal coding or modulation of the other remote control is not compatible with this remote control.	Learning is not possible.	—
	Memory capacity is full.	Delete other unnecessary functions to make room for the new functions.	127

## ■ HDMI

Error message	Cause	Remedy	See page
<b>Device Over</b>	The number of the connected HDMI components is over the limit.	Reduce the number of the connected HDMI components.	—
<b>HDCP Error</b>	HDCP authentication failed.	Check that the connected HDMI components support the HDCP copy protection standards.	—

## ■ Network and USB

Problem	Cause	Remedy	See page
<b>The PC server/MCX-2000/Internet Radio does not function properly.</b>	The IP address is not set properly.	Set the DHCP server function of the router to ON. Alternately, perform manual configuration according to the current operating environment.	109
	The network cable is not connected.	Connect it properly.	30
<b>The music in the PC server cannot be played back.</b>	The PC does not have Windows Media Connect 2.0 installed in it.	Install Windows Media Connect 2.0 in the PC.	—
	The music is recorded in a format that cannot be played on this unit. This unit cannot play music formats other than WMA, MP3 and WAV (PCM format). Also note that it cannot play certain music files even if these are recorded in the WMA, MP3 or WAV format.	Play music recorded in a format that this unit is compatible with.	—
	The music is copyright-protected.	This unit cannot play copyright-protected music.	—
<b>Windows Media Connect 2.0 cannot be connected.</b>	The Windows XP PC is logging on to a domain.	Log on to the local machine instead of the domain.	—
<b>The MusicCAST server cannot be connected.</b>	You are attempting to connect to MCX-1000. The MusicCAST server that can be connected by this unit is MCX-2000.	Use MCX-2000 or the PC server.	—
	Auto Configuration is not executed.	Execute "Auto Configure".	79

Problem	Cause	Remedy	See page
<b>“Disconnected” is displayed even when a USB device is present.</b>	This unit recognized the USB device as an illegal device.	Turn this unit off then on again.	81
<b>The Internet Radio cannot be played.</b>	The firewall of the network device is activated. The Internet Radio can be played only when it passes through the port designated by each radio station. The port number is variable depending on radio station.	Check the firewall setting of the network device.	—
	Connection to the Internet is disconnected.	Check the configuration of the network device, and then contact the network connection provider.	—
<b>The music files and directories in the USB device cannot be viewed.</b>	The music files and directories are placed in locations other than the FAT area.	Place music files and directories in the FAT area.	—
	You are attempting to browse directory hierarchies of over 8 levels or a directory with more than 500 files.	Modify the data structure on your USB device.	—
<b>The USB device cannot be recognized.</b>	The connected USB device is other than a USB mass storage class USB memory device or USB portable audio player.	This unit can recognize only a USB mass storage class USB memory device or USB portable audio player. Also note that it cannot recognize certain USB devices even when they are devices as described above.	81
		Some devices may become easier to recognize when they are inserted before turning this unit on.	81
<b>This unit does not recall the correct item by using numeric buttons (1-8).</b>	The connected USB device is incorrect.	Connect the USB device that stores the preset item.	81
	The directory that stores the selected item is changed.	Preset the desired item to the numeric button (1-8) again.	81
<b>This unit does not recall the selected item by using numeric buttons (1-8).</b>	The USB device is not connected correctly.	Connect the correct USB device properly.	81
	The PC or MCX-2000 that stores the selected item is turned off.	Turn on the PC or MCX-2000.	79
	The selected Internet Radio station is temporary unavailable or out of service.	Try again when the selected Internet Radio is providing the service.	80
		Preset other Internet Radio stations.	81
Status message	Cause	Remedy	See page
<b>Please wait</b>	This unit is in the middle of recognizing the connection with your network.	This is not a system malfunction. Wait for a while.	—
	This unit is in the middle of recognizing the connection with your USB memory device or USB portable audio player.	This is not a system malfunction. Wait for a while.	—
<b>Please wait (Starting Server)</b>	This unit is in the middle of waking up MCX-2000 that has been set to the standby mode.	Wait for approximately 20 seconds.	—

Status message	Cause	Remedy	See page
<b>Connect error</b>	There is a problem with the signal path from your network to this unit.	Check the connection between this unit and the LAN port on your router or hub.	30
		Make sure your router is properly connected and turned on. Also, make sure your modem is properly connected and turned on when you are attempting to listen to Internet Radio.	30
<b>Disconnected</b>	Your USB memory device or USB portable audio player has been disconnected from the USB port of this unit.	Check the connection between this unit and your USB memory device or USB portable audio player.	—
	The PC server or MCX-2000 previously connected to this unit no longer exists.	Connect this unit to the available PC server or MCX-2000.	79
	There is a problem with the signal path from your USB memory device or USB portable audio player to this unit.	Turn off this unit and reconnect your USB memory device or USB portable audio player to the USB port of this unit.	34
		Try resetting your USB memory device or USB portable audio player.	—
<b>Access error</b>	This unit cannot access your USB memory device or USB portable audio player.	Try another USB memory device or USB portable audio player.	—
	There is a problem with the signal path from your USB memory device or USB portable audio player to this unit.	Turn off this unit and reconnect your USB memory device or USB portable audio player to the USB port of this unit.	34
		Try resetting your USB memory device or USB portable audio player.	—
<b>Unable to play</b>	This unit cannot play back the songs currently stored on your PC.	Make sure Windows Media Connect 2.0 is installed on your PC.	—
		Check that the songs currently stored on your PC are playable (MP3, WMA, and WAV).	—
		Store some other playable music files (MP3, WMA, and WAV) on your PC.	—
	The network may be overloaded with heavy traffic, and playback is interrupted.	Try preparing a network exclusively for use with this unit to separate it from general network traffic.	—
<b>List updated</b>	The list of the contents stored on your PC server or MCX-2000 has been updated.		
<b>Bookmark ON</b>	The desired Internet Radio station has been added to the "Bookmarks" list.		
<b>Bookmark OFF</b>	The stored Internet Radio station has been removed from the "Bookmarks" list.		
<b>Empty Memory!</b>	No items are assigned to the selected numeric button.	Assign the desired item to the numeric button.	81
<b>Not found!</b>	This unit cannot find the assigned item for the selected numeric button.	Connect the USB device that stores the preset item.	
		Turn on the PC or MCX-2000.	79
		Try again when the selected Internet Radio is providing the service.	80
		Preset the desired item to the numeric button (1-8) again.	81

## ■ iPod

### Note

In case of a transmission error without a status message appearing in the front panel and on the video monitor, check the connection to your iPod (see page 29).

Status message	Cause	Remedy	See page
Loading...	This unit is in the middle of recognizing the connection with your iPod.		
	This unit is in the middle of acquiring song lists from your iPod.		
Connect error	There is a problem with the signal path from your iPod to this unit.	Turn off this unit and reconnect the YAMAHA iPod universal dock to the DOCK terminal of this unit.	29
		Try resetting your iPod.	—
Unknown iPod	The iPod being used is not supported by this unit.	Only iPod (Click and Wheel), iPod nano, and iPod mini are supported.	—
iPod connected	Your iPod is properly stationed in a YAMAHA iPod universal dock (such as the YDS-10, sold separately) connected to the DOCK terminal of this unit, and the connection between your iPod and this unit is complete.		
Disconnected	Your iPod was removed from a YAMAHA iPod universal dock (such as YDS-10 sold separately) connected to the DOCK terminal of this unit.	Station your iPod back in a YAMAHA iPod universal dock (such as YDS-10 sold separately) connected to the DOCK terminal of this unit.	29
Unable to play	This unit cannot play back the songs currently stored on your iPod.	Check that the songs currently stored on your iPod are playable.	—
		Store some other playable music files on your iPod.	—

## ■ Auto Setup

### Before Auto Setup

Error message	Cause	Remedy	See page
<b>Connect MIC!</b>	Optimizer microphone is not connected.	Connect the supplied optimizer microphone to the OPTIMIZER MIC jack on the front panel.	35
<b>Unplug Phones!</b>	Headphones are connected.	Unplug the headphones.	—
<b>No Setup Menu!</b>	All setup menu are set to “Skip”.	Set the desired menu item to “Check”.	36
<b>Memory Guard!</b>	“Memory Guard” is set to “On”.	Set “Memory Guard” to “Off”.	114

## During Auto Setup

Error message	Cause	Remedy	See page
<b>E01:No Front SP</b>	Front L/R channel signals are not detected.	Check the front L/R speaker connections.	16
<b>E02:No Sur. SP</b>	A surround channel signal is not detected.	Check the surround speaker connections.	16
<b>E03:No PRNS SP</b>	A presence channel signal is not detected.	Check the presence speaker connections.	16
<b>E04:SBR-&gt;SBL</b>	Only right surround back channel signal is detected.	Connect the surround back speaker to the LEFT SURROUND BACK SPEAKERS terminal if you only have one surround back speaker.	16
<b>E05:Noisy</b>	Background noise is too loud.	Try running "Auto Setup" in a quiet environment.	—
		Turn off noisy electric equipment like air conditioners or move them away from the optimizer microphone.	—
<b>E06:Check Sur.</b>	Surround back speakers are connected, though surround L/R speakers are not.	Connect surround speakers when you use surround back speakers.	16
<b>E07:No MIC</b>	The optimizer microphone was unplugged during the "Auto Setup" procedure.	Connect the supplied optimizer microphone to the OPTIMIZER MIC jack on the front panel.	35
<b>E08:No Signal</b>	The optimizer microphone does not detect test tones.	Check the microphone setting.	35
		Check the speaker connections and placement.	16
<b>E09:User Cancel</b>	The "Auto Setup" procedure was cancelled due to user activity.	Run "Auto Setup" again.	35
<b>E10:Internal Err.</b>	An internal error occurred.	Run "Auto Setup" again.	35

## After Auto Setup

Warning message	Cause	Remedy	See page
<b>W1:Out of Phase</b>	Speaker polarity is not correct. This message may appear depending on the speakers even when the speakers are connected correctly.	Check the speaker connections for proper polarity (+ or -).	16
<b>W2:Over Distance</b>	The distance between the speaker and the listening position is over 24 m (80 ft).	Bring the speaker closer to the listening position.	—
<b>W3:Level Error</b>	The difference of volume level among speakers is excessive.	Readjust the speaker installation so that all speakers are set in locations with similar conditions.	—
		Check the speaker connections.	16
		Use speakers of similar quality.	—
		Adjust the output volume of the subwoofer.	35
<b>W4:SP Mismatch</b>	The result of the wiring check of "Auto Setup" is different from "Speaker Set" in "Manual Setup".	Use "Speaker Set" in "Manual Setup" to adjust the speaker settings manually.	105

## Notes

- If the "ERROR" or "WARNING" screens appears, check the cause of the problem, then run "Auto Setup" again.
- If warning "W1" appears, corrections are made, but they may not be optimal.
- If warning "W2" or "W3" appears, no corrections are made.
- If error "E10" occurs repeatedly, please contact a qualified YAMAHA service center.



# RESETTING THE SYSTEM

Use this feature to reset all the parameters of this unit to the initial factory settings.

## Notes

- This procedure completely resets all the parameters of this unit. However, the advanced setup menu parameters will not be initialized.
- The initial factory settings are activated next time you turn on this unit.



To cancel the initialization procedure at any time without making any changes, press MASTER ON/OFF on the front panel to release it outward to the OFF position.

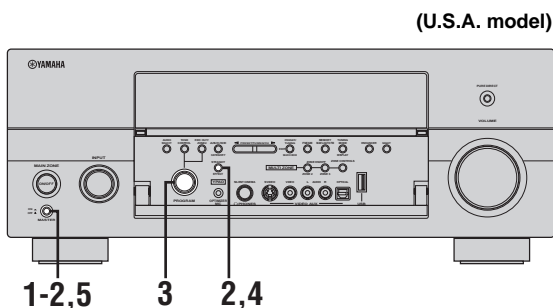

- 1 Press **MASTER ON/OFF** on the front panel to release it outward to the OFF position to turn off this unit.



- 2 Press and hold **STRAIGHT** on the front panel and then press **MASTER ON/OFF** inward to the ON position to turn on this unit.

This unit turns on, and the advanced setup menu appears in the front panel display.



- 3 Rotate the **PROGRAM** selector on the front panel to select “PRESET”.



USER PRESET  
CANCEL

- 4 Press **STRAIGHT** on the front panel repeatedly to select “RESET”.



USER PRESET  
RESET



Select “CANCEL” to cancel the initialization procedure without making any changes.

- 5 Press **MASTER ON/OFF** on the front panel to release it outward to the OFF position to confirm your selection and turn off this unit.



# GLOSSARY

## ■ Bi-amplification connection

A bi-amplification connection uses two amplifiers for a speaker. One amplifier is connected to the woofer section of a loudspeaker while the other is connected to the combined mid and tweeter section. With this arrangement each amplifier operates over a restricted frequency range. This restricted range presents each amplifier with a much simpler job and each amplifier is less likely to influence the sound in some way. The internal crossover of the speaker consists of a LPF (low pass filter) and a HPF (high pass filter). As its name implies, the LPF passes frequencies below a cutoff and rejects frequencies above the cutoff frequency. Likewise, the HPF passes frequencies above its cutoff.

## ■ Component video signal

With the component video signal system, the video signal is separated into the Y signal for the luminance and the P<sub>b</sub> and P<sub>r</sub> signals for the chrominance. Color can be reproduced more faithfully with this system because each of these signals is independent. The component signal is also called the “color difference signal” because the luminance signal is subtracted from the color signal. A monitor with component input jacks is required in order to output component signals.

## ■ Composite video signal

With the composite video signal system, the video signal is composed of three basic elements of a video picture: color, brightness and synchronization data. A composite video jack on a video component transmits these three elements combined.

## ■ Dialogue normalization

Dialogue Normalization is a feature of Dolby Digital or DTS, which is used to keep the programs at the same average listening level so the user does not have to change the volume control between Dolby Digital or DTS programs.

## ■ Dolby Digital

Dolby Digital is a digital surround sound system that gives you completely independent multi-channel audio. With 3 front channels (front L/R and center), and 2 surround stereo channels, Dolby Digital provides 5 full-range audio channels. With an additional channel especially for bass effects, called LFE (Low Frequency Effect), the system has a total of 5.1-channels (LFE is counted as 0.1 channel). By using 2-channel stereo for the surround speakers, more accurate moving sound effects and surround sound environment are possible than with Dolby Surround. The wide dynamic range from maximum to minimum volume reproduced by the 5 full-range channels and the precise sound orientation generated using digital sound processing provide listeners with unprecedented excitement and realism. With this unit, any sound environment from monaural up to a 5.1-channel configuration can be freely selected for your enjoyment.

## ■ Dolby Digital EX

Dolby Digital EX creates 6 full-bandwidth output channels from 5.1-channel sources. This is done using a matrix decoder that derives 3 surround channels from the 2 in the original recording. For the best results, Dolby Digital EX should be used with movie sound tracks recorded with Dolby Digital Surround EX. With this additional channel, you can experience more dynamic and realistic moving sound especially with scenes with “fly-over” and “fly-around” effects.

## ■ Dolby Pro Logic II

Dolby Pro Logic II is an improved technique used to decode vast numbers of existing Dolby Surround sources. This new technology enables a discrete 5-channel playback with 2 front left and right channels, 1 center channel, and 2 surround left and right channels instead of only 1 surround channel for conventional Pro Logic technology. There are three modes available: “Music mode” for music sources, “Movie mode” for movie sources and “Game mode” for game sources.

## ■ Dolby Pro Logic IIx

Dolby Pro Logic IIx is a new technology enabling discrete multi-channel playback from 2-channel or multi-channel sources. There are three modes available: “Music mode” for music sources, “Movie mode” for movie sources (for 2-channel sources only) and “Game mode” for game sources.

## ■ Dolby Surround

Dolby Surround uses a 4-channel analog recording system to reproduce realistic and dynamic sound effects: 2 front left and right channels (stereo), a center channel for dialog (monaural), and a surround channel for special sound effects (monaural). The surround channel reproduces sound within a narrow frequency range. Dolby Surround is widely used with nearly all video tapes and laser discs, and in many TV and cable broadcasts as well. The Dolby Pro Logic decoder built into this unit employs a digital signal processing system that automatically stabilizes the volume on each channel to enhance moving sound effects and directionality.

## ■ DSD

Direct Stream Digital (DSD) technology stores audio signals on digital storage media, such as Super Audio CDs. Using DSD, signals are stored as single bit values at a high-frequency sampling rate of 2.8224 MHz, while noise shaping and oversampling are used to reduce distortion, a common occurrence with very high quantization of audio signals. Due to the high sampling rate, better audio quality can be achieved than that offered by the PCM format used for normal audio CDs.

## ■ DTS 96/24

DTS 96/24 offers an unprecedented level of audio quality for multi-channel sound on DVD video, and is fully backward-compatible with all DTS decoders. “96” refers to a 96 kHz sampling rate compared to the typical 48 kHz sampling rate. “24” refers to 24-bit word length. DTS 96/24 offers sound quality transparent to the original 96/24 master, and 96/24 5.1-channel sound with full-quality full-motion video for music programs and motion picture soundtracks on DVD video.

## ■ DTS (Digital Theater Systems) Digital Surround

DTS digital surround was developed to replace the analog soundtracks of movies with a 6.1-channel digital sound track, and is now rapidly gaining popularity in movie theaters around the world. Digital Theater Systems Inc. has developed a home theater system so that you can enjoy the depth of sound and natural spatial representation of DTS digital surround in your home. This system produces practically distortion-free 6.1-channel sound (technically, front left and right, center, surround left and right, and LFE 0.1 (subwoofer) channels for a total of 5.1 channels). This unit incorporates a DTS-ES decoder that enables 6.1-channel reproduction by adding the surround back channel to the existing 5.1-channel format.

## ■ HDMI

HDMI (High-Definition Multimedia Interface) is the first industry-supported, uncompressed, all-digital audio/video interface. Providing an interface between any source (such as a set-top box or AV receiver) and an audio/video monitor (such as a digital television), HDMI supports standard, enhanced or high-definition video as well as multi-channel digital audio using a single cable. HDMI transmits all ATSC HDTV standards and supports 8-channel digital audio, with bandwidth to spare to accommodate future enhancements and requirements. When used in combination with HDCP (High-bandwidth Digital Content Protection), HDMI provides a secure audio/video interface that meets the security requirements of content providers and system operators. For further information on HDMI, visit the HDMI website at “<http://www.hdmi.org>”.

## ■ LFE 0.1 channel

This channel reproduces low-frequency signals. The frequency range of this channel is from 20 Hz to 120 Hz. This channel is counted as 0.1 because it only enforces a low-frequency range compared to the full-range reproduced by the other 5/6 channels in Dolby Digital or DTS 5.1/6.1-channel systems.

## ■ MP3

One of the audio compression methods used by MPEG. It employs the irreversible compression method, which achieves a high compression rate by thinning out the data of hardly audible part to the human ears. It is said to be capable of compressing the data quantity by about 1/11 (128 kbps) while maintaining a similar audio quality to music CD.

## ■ Neo:6

Neo:6 decodes the conventional 2-channel sources for 6-channel playback by the specific decoder. It enables playback with the full-range channels with higher separation just like digital discrete signal playback. There are two modes available: “Music mode” for music sources and “Cinema mode” for movie sources.

## ■ Neural Surround

Neural Surround™ represents the latest advancement in surround technology and has been adopted by XM Satellite Radio for digital radio broadcast of surround recordings and live events in surround sound. Neural Surround™ employs psychoacoustic frequency domain processing which allows delivery of a more detailed sound stage with superior channel separation and localization of audio elements. System playback is scalable from 5.1 to 7.1 multi-channel surround playback.

**■ PCM (Linear PCM)**

Linear PCM is a signal format under which an analog audio signal is digitized, recorded and transmitted without using any compression. This is used as a method of recording CDs and DVD audio. The PCM system uses a technique for sampling the size of the analog signal per very small unit of time. Standing for “Pulse Code Modulation”, the analog signal is encoded as pulses and then modulated for recording.

**■ Sampling frequency and number of quantized bits**

When digitizing an analog audio signal, the number of times the signal is sampled per second is called the sampling frequency, while the degree of fineness when converting the sound level into a numeric value is called the number of quantized bits. The range of rates that can be played back is determined based on the sampling rate, while the dynamic range representing the sound level difference is determined by the number of quantized bits. In principle, the higher the sampling frequency, the wider the range of frequencies that can be played back, and the higher the number of quantized bits, the more finely the sound level can be reproduced.

**■ S-video signal**

With the S-video signal system, the video signal normally transmitted using a pin cable is separated and transmitted as the Y signal for the luminance and the C signal for the chrominance through the S-video cable. Using the S VIDEO jack eliminates video signal transmission loss and allows recording and playback of even more beautiful images.

**■ WAV**

Windows standard audio file format, which defines the method of recording the digital data obtained by converting audio signals. It does not specify the compression (coding) method so a desired compression method can be used with it. By default, it is compatible with the PCM method (no compression) and some compression methods including the ADPCM method.

**■ WMA**

An audio compression method developed by Microsoft Corporation. It employs the irreversible compression method, which achieves a high compression rate by thinning out the data of hardly audible part to the human ears. It is said to be capable of compressing the data quantity by about 1/22 (64 kbps) while maintaining a similar audio quality to music CD.

# SOUND FIELD PROGRAM INFORMATION

## ■ Elements of a sound field

What really creates the rich, full tones of a live instrument are the multiple reflections from the walls of the room. In addition to making the sound live, these reflections enable us to tell where the player is situated as well as the size and shape of the room in which we are sitting.

There are two distinct types of sound reflections that combine to make up the sound field in addition to the direct sound coming straight to our ears from the player's instrument.

### Early reflections

Reflected sounds reach our ears extremely rapidly (50 ms to 100 ms after the direct sound), after reflecting from one surface only (for example, from a wall or the ceiling). Early reflections actually add clarity to the direct sound.

### Reverberations

These are caused by reflections from more than one surface (for example, from the walls, and the ceiling) so numerous that they merge together to form a continuous sonic afterglow. They are non-directional and lessen the clarity of the direct sound.

Direct sound, early reflections and subsequent reverberations taken together help us to determine the subjective size and shape of the room, and it is this information that the digital sound field processor reproduces in order to create sound fields.

If you could create the appropriate early reflections and subsequent reverberations in your listening room, you would be able to create your own listening environment. The acoustics in your room could be changed to those of a concert hall, a dance floor, or a room with virtually any size at all. This ability to create sound fields at will is exactly what YAMAHA has done with the digital sound field processor.

## ■ CINEMA DSP

Since the Dolby Surround and DTS systems were originally designed for use in movie theaters, their effect is best felt in a theater having many speakers designed for acoustic effects. Since home conditions, such as room size, wall material, number of speakers, and so on, can differ so widely, it is inevitable that there are differences in the sound heard. Based on a wealth of actually measured data, YAMAHA CINEMA DSP uses YAMAHA original sound field technology to combine Dolby Pro Logic, Dolby Digital and DTS systems to provide the audiovisual experience of a movie theater in the listening room of your own home.

## ■ SILENT CINEMA

YAMAHA has developed a natural, realistic sound effect DSP algorithm for headphones. Parameters for headphones have been set for each sound field so that accurate representations of all the sound field programs can be enjoyed on headphones.

## ■ Virtual CINEMA DSP

YAMAHA has developed a Virtual CINEMA DSP algorithm that allows you to enjoy DSP sound field surround effects even without any surround speakers by using virtual surround speakers. It is even possible to enjoy Virtual CINEMA DSP using a minimal two-speaker system that does not include a center speaker.

## ■ Sound output from each speaker

Sound output from each speaker depends on the type of audio signals being input. Refer to the diagrams in the table below to understand the speaker layout for each sound field program. For details about the sound output from each speaker in sound field programs, refer to "SOUND OUTPUT IN EACH SOUND FIELD PROGRAM" in "APPENDIX" at the end of this manual.

### Note

Be advised that there may be no or not enough sound output from speakers depending on the type of input source being played back. Furthermore, there may be some channels that can only be used partially when they are adjusted to specific aspects of movies, such as special sound effects, etc.



Except for "2ch Stereo", "7ch Stereo", and "STRAIGHT", you can select a decoder to output sound from the surround back speakers (see page 47).

# PARAMETRIC EQUALIZER INFORMATION

This unit employs YAMAHA Parametric Room Acoustic Optimizer (YPAO) technology, together with the Parametric EQ settings (see page 98), to optimize the frequency characteristics of its parametric equalizer to match your listening environment. YPAO uses a combination of the following three parameters (Frequency, Gain and Q factor) to provide highly precise adjustment of the frequency characteristics.

## ■ Frequency

This parameter is adjustable in one-third octave increments between 32 Hz and 16 kHz.

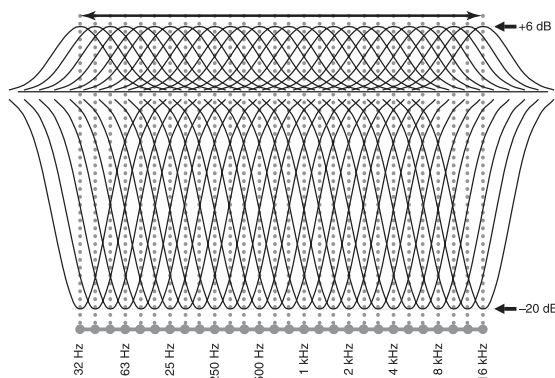

## ■ Gain

This parameter is adjustable in increments of 0.5 dB between -20 and +6 dB.

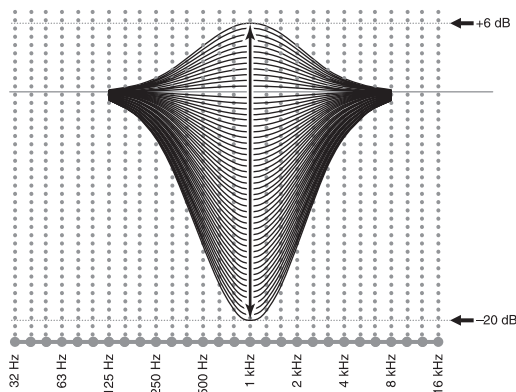

## ■ Q factor

The width of the specified frequency band is referred to as the Q factor. This parameter is adjustable between the values 0.5 and 10.

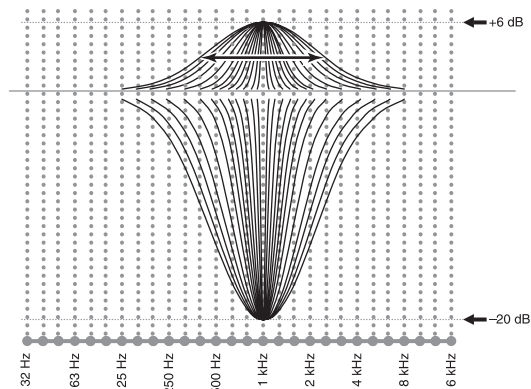

YPAO adjusts frequency characteristics to suit your listening requirements using a combination of the above three parameters (Frequency, Gain and Q factor) for each equalizer band in this unit's parametric equalizer. This unit has 7 equalizer bands for each channel.

The use of multiple equalizer bands enables more precise adjustments of frequency characteristics (as in Figure 2). This is not possible using only a single equalizer band (as in Figure 1).

Figure 1

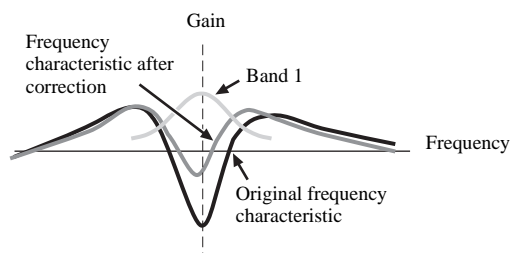
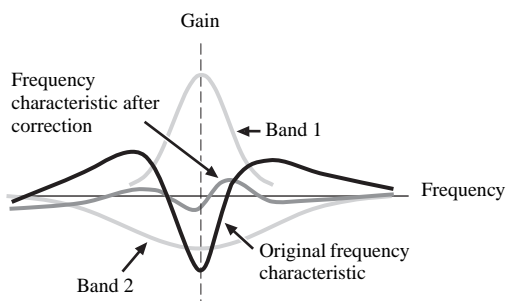

Figure 2



# SPECIFICATIONS

## AUDIO SECTION

- Minimum RMS Output Power for Front, Center, Surround, Surround back  
20 Hz to 20 kHz, 0.04% THD, 8 Ω ..... 140 W
- Dynamic Power (IHF)  
8/6/4/2 Ω ..... 170/205/265/345 W
- Maximum Useful Output Power (JEITA)  
[Asia, General, China and Korea models]  
1 kHz, 10% THD, 8 Ω ..... 185 W
- Maximum Output Power [U.K. and Europe models]  
1 kHz, 0.7% THD, 4 Ω ..... 200 W
- Dynamic Headroom  
8 Ω ..... 0.84 dB
- IEC Output Power [U.K. and Europe models]  
1 kHz, 0.04% THD, 8 Ω ..... 145 W
- Damping Factor (IHF)  
20 Hz to 20 kHz, 8 Ω ..... 150 or more
- Input Sensitivity/Input Impedance  
PHONO ..... 3.5 mV/47 kΩ  
CD, etc. .... 200 mV/47 kΩ  
MULTI CH INPUT ..... 200 mV/47 kΩ
- Maximum Input Voltage  
PHONO (1 kHz, 0.1% THD) ..... 60 mV or more  
CD, etc. (1 kHz, 0.5% THD) ..... 2.4 V or more
- Rated Output Voltage/Output Impedance  
OUT (REC) ..... 200 mV/900 Ω  
PRE OUT ..... 1.0 V/1.2 kΩ  
SUBWOOFER ..... 2.0 V/1.2 kΩ  
ZONE 2/ZONE 3 OUT ..... 1.0 V/1.4 kΩ
- Headphone Jack Rated Output/Impedance  
CD, etc. (1 kHz, 40 mV, 8 Ω) ..... 150 mV/100 Ω
- Frequency Response  
CD to Front L/R, Pure Direct ..... 10 Hz to 100 kHz, +0/-3 dB
- RIAA Equalization Deviation  
PHONO (20 Hz to 20 kHz) ..... 0 ± 0.5 dB
- Total Harmonic Distortion  
PHONO to OUT (REC)  
(20 Hz to 20 kHz, 1 V) ..... 0.02% or less  
CD, etc. to Front L/R  
(20 Hz to 20 kHz, 70 W, 8 Ω) ..... 0.04% or less
- Signal to Noise Ratio (IHF-A Network)  
PHONO (5 mV) to Front L/R  
[Australia, U.K. and Europe models] ..... 81 dB or more  
[Other models] ..... 86 dB or more  
CD, etc. (250 mV) to Front L/R ..... 100 dB or more
- Residual Noise (IHF-A Network)  
Front L/R ..... 150 μV or less
- Channel Separation (1 kHz/10 kHz)  
PHONO (shortened) to Front L/R ..... 60 dB/55 dB or more  
CD, etc.  
(5.1 kΩ shortened) to Front L/R ..... 60 dB/45 dB or more

- Tone Control (Front L/R)  
BASS Boost/Cut ..... ±6 dB/50 Hz  
BASS Turnover Frequency ..... 125/350/500 Hz  
TREBLE Boost/Cut ..... ±6 dB/20 kHz  
TREBLE Turnover Frequency ..... 2.5/3.5/8.0 kHz
- Zone 2/Zone 3 Tone Control (Front L/R)  
BASS Boost/Cut ..... ±10 dB/100 Hz  
BASS Turnover Frequency ..... 450 Hz  
TREBLE Boost/Cut ..... ±10 dB/10 kHz  
TREBLE Turnover Frequency ..... 2.0 kHz
- Filter Characteristics (fc=40/60/80/90/100/110/120/160/200 Hz)  
H.P.F. (Front, Center, Surround, Surround back) ..... 12 dB/oct.  
L.P.F. (Subwoofer) ..... 24 dB/oct.

## VIDEO SECTION

- Video Format [MONITOR OUT] (Wall Paper)  
[U.S.A., Canada, General and Korea models] ..... NTSC/PAL  
[U.K., Europe, Australia, Asia and China models] ..... PAL/NTSC
- Video Format (Video Conversion)  
..... NTSC/PAL
- Signal Level  
Composite ..... 1 Vp-p/75 Ω  
S-video ..... 1 Vp-p/75 Ω (Y), 0.286 Vp-p/75 Ω (C)  
Component ..... 1 Vp-p/75 Ω (Y), 0.7 Vp-p/75 Ω (Pb/Pk)
- Maximum Input Level (Video Conversion Off)  
..... 1.5 Vp-p or more
- Signal to Noise Ratio (Video Conversion Off)  
..... 60 dB or more
- Frequency Response [MONITOR OUT]  
Component (Video Conversion Off)  
..... 5 Hz to 100 MHz, ±3 dB
- Video Format [ZONE OUT] (Gray Back)  
[U.S.A., Canada, General and Korea models] ..... NTSC  
[U.K., Europe, Australia, Asia and China models] ..... PAL

## FM SECTION

- Tuning Range  
[U.S.A. and Canada models] ..... 87.5 to 107.9 MHz  
[Asia and General models] ..... 87.5/87.50 to 108.0/108.00 MHz  
[Other models] ..... 87.50 to 108.00 MHz
- 50 dB Quieting Sensitivity (IHF)  
Mono/Stereo ..... 2.0/25 μV (17.3/39.2 dBf)
- Usable Sensitivity (IHF) ..... 1.0 μV (11.2 dBf)
- Selectivity (400 kHz) ..... 70 dB
- Signal to Noise Ratio (IHF)  
Mono/Stereo ..... 76 dB/70 dB
- Harmonic Distortion (1 kHz)  
Mono/Stereo ..... 0.2/0.3%
- Stereo Separation (1 kHz)  
Stereo ..... 42 dB
- Frequency Response  
Stereo ..... 20 Hz to 15 kHz, +0.5, -2 dB
- Antenna Input (unbalanced) ..... 75 Ω

**AM SECTION**

- Tuning Range
  - [U.S.A. and Canada models] ..... 530 to 1710 kHz
  - [Asia and General models] ..... 530/531 to 1710/1611 kHz
  - [Other models] ..... 531 to 1611 kHz
- Usable Sensitivity ..... 300  $\mu$ V/m

**GENERAL**

- Power Supply
  - [U.S.A. and Canada models] ..... AC 120 V, 60 Hz
  - [General and Asia model]
    - ..... AC 110/120/220/230–240 V, 50/60 Hz
  - [China model] ..... AC 220 V, 50 Hz
  - [Korea model] ..... AC 220 V, 60 Hz
  - [Australia model] ..... AC 240 V, 50 Hz
  - [U.K. and Europe models] ..... AC 230 V, 50 Hz
- Power Consumption
  - [U.S.A. and Canada models] ..... 500 W/630 VA
  - [Other models] ..... 500 W
- Standby Power Consumption
  - [U.S.A. and Canada models] ..... 0.1 W or less
  - [General model] (AC 240 V, 50 Hz) ..... 0.33 W or less
  - [Other models] ..... 0.1 W or less
- Maximum Power Consumption [General model only]
  - 6ch, 10% THD ..... 1100 W
- AC Outlets
  - [U.S.A. and Canada models] .... 2 (Total 100 W/0.8 A maximum)
  - [Asia, General and China models] ..... 2 (Total 50 W maximum)
  - [Australia and U.K. models] .... 1 (Total 100 W/0.4 A maximum)
  - [Europe model] ..... 2 (Total 100 W/0.4 A maximum)
- Dimensions (W x H x D) ..... 435 x 171 x 438.5 mm  
(17.1 x 6.7 x 17.3 in)
- Weight ..... 17.2 kg (37.9 lbs)

\* Specifications are subject to change without notice.



# SOUND OUTPUT IN EACH SOUND FIELD PROGRAM

- L Front left speaker
- C Center speaker
- R Front right speaker
- SL Surround left speaker
- SR Surround right speaker
- SBL Surround back left speaker
- SBR Surround back right speaker
- PL Presence left speaker
- PR Presence right speaker
- Speaker from which sound is being output
- Speaker from which no sound is being output

\*1 00 EX / 00 PL IIx / **DTS** : OFF

\*2 00 EX / 00 PL IIx / **DTS** : ON, PRIORITY: PRNS

\*3 00 EX / 00 PL IIx / **DTS** : ON, PRIORITY: SB

Program	Input source				
	2-channel audio (monaural)	2-channel audio (stereo)	5.1/6.1-channel audio *1	5.1/6.1-channel audio *2	5.1/6.1-channel audio *3
<b>CLASSICAL</b> Hall in Munich Hall in Vienna Hall in Amsterdam Church in Freiburg Chamber <b>LIVE/CLUB</b> Village Vanguard Warehouse Loft Cellar Club The Roxy Theatre The Bottom Line					
<b>ENTERTAINMENT</b> Sports Music Video Recital/Opera					
<b>ENTERTAINMENT</b> Action Game Roleplaying Game					
<b>MOVIE</b> <b>STANDARD</b> (PRO LOGIC)					
			(Dolby Digital) / (DTS)	(Dolby Digital) / (DTS)	(Dolby Digital) / (DTS)

Program	Input source				
	2-channel audio (monaural)	2-channel audio (stereo)	5.1/6.1-channel audio *1	5.1/6.1-channel audio *2	5.1/6.1-channel audio *3
<b>MOVIE</b> <b>STANDARD</b> (PLII Movie) (PLIIX Movie) (Neo:6 Cinema)					
		PRIORITY: PRMS	(Dolby Digital) / (DTS)	(Dolby Digital) / (DTS)	(Dolby Digital) / (DTS)
		PRIORITY: SB			
<b>MOVIE</b> Spectacle Sci-Fi Adventure Drama Mono Movie					
<b>STEREO</b> 2ch Stereo					
	Monaural playback				
<b>STEREO</b> 7ch Stereo					

Program	Input source				
	2-channel audio (monaural)	2-channel audio (stereo)	5.1/6.1-channel audio *1	5.1/6.1-channel audio *2	5.1/6.1-channel audio *3

**SURROUND DECODE  
PRO LOGIC**

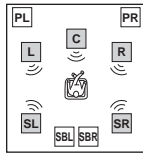
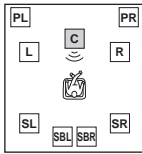

PRO LOGIC

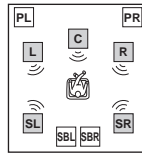

Dolby Digital  
/  
DTS

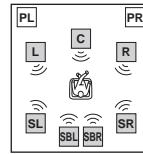

Dolby Digital  
/  
DTS

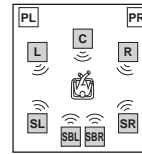

Dolby Digital  
/  
DTS

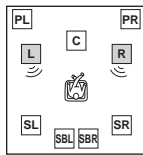

Dolby Digital  
/  
DTS

**SURROUND DECODE  
PLII Movie  
PLII Music  
PLII Game**

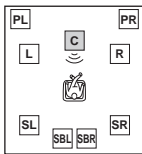

Movie/Game

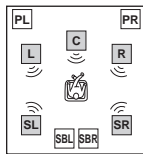

Movie/Music/Game

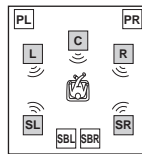

Dolby Digital  
/  
DTS

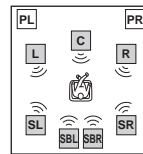

Dolby Digital  
/  
DTS

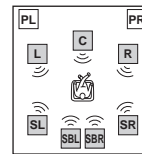

Dolby Digital  
/  
DTS

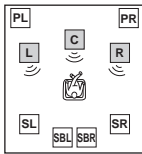

Music

**SURROUND DECODE  
PLIIX Movie  
PLIIX Music  
PLIIX Game**

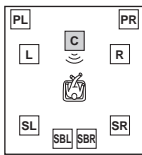

Movie/Game

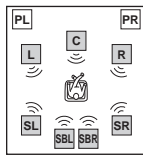

Movie/Music/Game

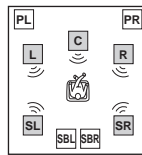

Dolby Digital  
/  
DTS

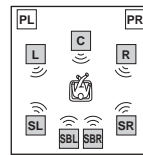

Dolby Digital  
/  
DTS

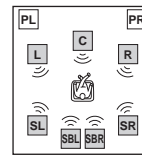

Dolby Digital  
/  
DTS

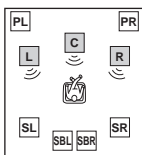

Music

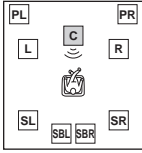
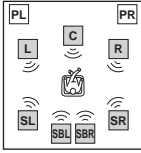
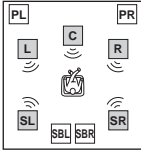
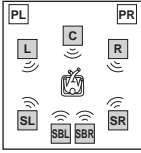
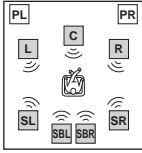
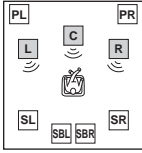
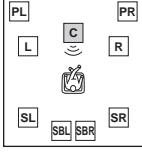
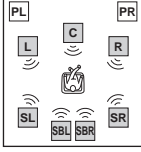
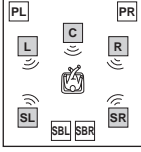
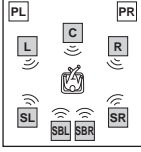
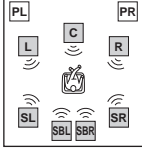
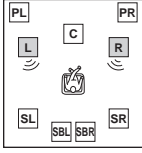
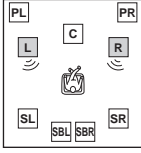
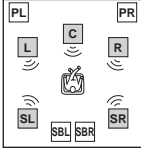
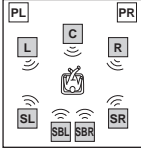
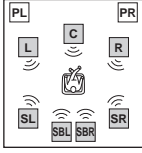
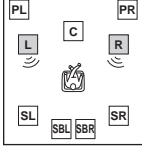
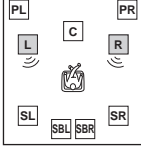
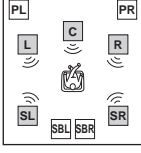
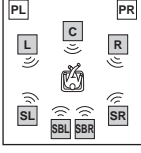
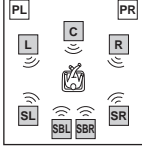
Program	Input source				
	2-channel audio (monaural)	2-channel audio (stereo)	5.1/6.1-channel audio *1	5.1/6.1-channel audio *2	5.1/6.1-channel audio *3
SURROUND DECODE Neo:6 Cinema Neo:6 Music					
	Cinema	Cinema/Music	Dolby Digital / DTS	Dolby Digital / DTS	Dolby Digital / DTS
					
	Music				
SURROUND DECODE neural sur.					
			Dolby Digital / DTS	Dolby Digital / DTS	Dolby Digital / DTS
STRAIGHT					
	Monaural playback				
PURE DIRECT					
	Monaural playback				

# GPL/LGPL

## ■ GNU GENERAL PUBLIC LICENSE

Version 2, June 1991

Copyright (C) 1989, 1991 Free Software Foundation, Inc. 59 Temple Place, Suite 330, Boston, MA 02111-1307 USA Everyone is permitted to copy and distribute verbatim copies of this license document, but changing it is not allowed.

### Preamble

The licenses for most software are designed to take away your freedom to share and change it. By contrast, the GNU General Public License is intended to guarantee your freedom to share and change free software—to make sure the software is free for all its users. This General Public License applies to most of the Free Software Foundation's software and to any other program whose authors commit to using it. (Some other Free Software Foundation software is covered by the GNU Library General Public License instead.) You can apply it to your programs, too.

When we speak of free software, we are referring to freedom, not price. Our General Public Licenses are designed to make sure that you have the freedom to distribute copies of free software (and charge for this service if you wish), that you receive source code or can get it if you want it, that you can change the software or use pieces of it in new free programs; and that you know you can do these things.

To protect your rights, we need to make restrictions that forbid anyone to deny you these rights or to ask you to surrender the rights. These restrictions translate to certain responsibilities for you if you distribute copies of the software, or if you modify it.

For example, if you distribute copies of such a program, whether gratis or for a fee, you must give the recipients all the rights that you have. You must make sure that they, too, receive or can get the source code. And you must show them these terms so they know their rights.

We protect your rights with two steps: (1) copyright the software, and (2) offer you this license which gives you legal permission to copy, distribute and/or modify the software.

Also, for each author's protection and ours, we want to make certain that everyone understands that there is no warranty for this free software. If the software is modified by someone else and passed on, we want its recipients to know that what they have is not the original, so that any problems introduced by others will not reflect on the original authors' reputations.

Finally, any free program is threatened constantly by software patents. We wish to avoid the danger of redistributors of a free program will individually obtain patent licenses, in effect making the program proprietary. To prevent this, we have made it clear that any patent must be licensed for everyone's free use or not licensed at all.

The precise terms and conditions for copying, distribution and modification follow.

### TERMS AND CONDITIONS FOR COPYING, DISTRIBUTION AND MODIFICATION

0. This License applies to any program or other work which contains a notice placed by the copyright holder saying it may be distributed under the terms of this General Public License. The "Program", below, refers to any such program or work, and a "work based on the Program" means either the Program or any derivative work under copyright law: that is to say, a work containing the Program or a portion of it, either verbatim or with modifications and/or translated into another language. (Hereinafter, translation is included without limitation in the term "modification".) Each licensee is addressed as "you".

Activities other than copying, distribution and modification are not covered by this License; they are outside its scope. The act of running the Program is not restricted, and the output from the Program is covered only if its contents constitute a work based on the Program (independent of having been made by running the Program). Whether that is true depends on what the Program does.

1. You may copy and distribute verbatim copies of the Program's source code as you receive it, in any medium, provided that you conspicuously and appropriately publish on each copy an appropriate copyright notice and disclaimer of warranty; keep intact all the notices that refer to this License and to the absence of any warranty; and give any other recipients of the Program a copy of this License along with the Program.

You may charge a fee for the physical act of transferring a copy, and you may at your option offer warranty protection in exchange for a fee.

2. You may modify your copy or copies of the Program or any portion of it, thus forming a work based on the Program, and copy and distribute such modifications or work under the terms of Section 1 above, provided that you also meet all of these conditions:
  - a) You must cause the modified files to carry prominent notices stating that you changed the files and the date of any change.
  - b) You must cause any work that you distribute or publish, that in whole or in part contains or is derived from the Program or any part thereof, to be licensed as a whole at no charge to all third parties under the terms of this License.
  - c) If the modified program normally reads commands interactively when run, you must cause it, when started running for such interactive use in the most ordinary way, to print or display an announcement including an appropriate copyright notice and a notice that there is no warranty (or else, saying that you provide a warranty) and that users may redistribute the program under

these conditions, and telling the user how to view a copy of this License. (Exception: if the Program itself is interactive but does not normally print such an announcement, your work based on the Program is not required to print an announcement.)

These requirements apply to the modified work as a whole. If identifiable sections of that work are not derived from the Program, and can be reasonably considered independent and separate works in themselves, then this License, and its terms, do not apply to those sections when you distribute them as separate works. But when you distribute the same sections as part of a whole which is a work based on the Program, the distribution of the whole must be on the terms of this License, whose permissions for other licensees extend to the entire whole, and thus to each and every part regardless of who wrote it.

Thus, it is not the intent of this section to claim rights or contest your rights to work written entirely by you; rather, the intent is to exercise the right to control the distribution of derivative or collective works based on the Program.

In addition, mere aggregation of another work not based on the Program with the Program (or with a work based on the Program) on a volume of a storage or distribution medium does not bring the other work under the scope of this License.

3. You may copy and distribute the Program (or a work based on it, under Section 2) in object code or executable form under the terms of Sections 1 and 2 above provided that you also do one of the following:
  - a) Accompany it with the complete corresponding machine-readable source code, which must be distributed under the terms of Sections 1 and 2 above on a medium customarily used for software interchange; or,
  - b) Accompany it with a written offer, valid for at least three years, to give any third party, for a charge no more than your cost of physically performing source distribution, a complete machine-readable copy of the corresponding source code, to be distributed under the terms of Sections 1 and 2 above on a medium customarily used for software interchange; or,
  - c) Accompany it with the information you received as to the offer to distribute corresponding source code. (This alternative is allowed only for noncommercial distribution and only if you received the program in object code or executable form with such an offer, in accord with Subsection b above.)

The source code for a work means the preferred form of the work for making modifications to it. For an executable work, complete source code means all the source code for all modules it contains, plus any associated interface definition files, plus the scripts used to control compilation and installation of the executable. However, as a special exception, the source code distributed need not include anything that is normally distributed (in either source or binary form) with the major components (compiler, kernel, and so on) of the operating system on which the executable runs, unless that component itself accompanies the executable.

If distribution of executable or object code is made by offering access to copy from a designated place, then offering equivalent access to copy the source code from the same place counts as distribution of the source code, even though third parties are not compelled to copy the source along with the object code.

4. You may not copy, modify, sublicense, or distribute the Program except as expressly provided under this License. Any attempt otherwise to copy, modify, sublicense or distribute the Program is void, and will automatically terminate your rights under this License. However, parties who have received copies, or rights, from you under this License will not have their licenses terminated so long as such parties remain in full compliance.
5. You are not required to accept this License, since you have not signed it. However, nothing else grants you permission to modify or distribute the Program or its derivative works. These actions are prohibited by law if you do not accept this License. Therefore, by modifying or distributing the Program (or any work based on the Program), you indicate your acceptance of this License to do so, and all its terms and conditions for copying, distributing or modifying the Program or works based on it.
6. Each time you redistribute the Program (or any work based on the Program), the recipient automatically receives a license from the original licensor to copy, distribute or modify the Program subject to these terms and conditions. You may not impose any further restrictions on the recipients' exercise of the rights granted herein. You are not responsible for enforcing compliance by third parties to this License.
7. If, as a consequence of a court judgment or allegation of patent infringement or for any other reason (not limited to patent issues), conditions are imposed on you (whether by court order, agreement or otherwise) that contradict the conditions of this License, they do not excuse you from the conditions of this License. If you cannot distribute so as to satisfy simultaneously your obligations under this License and any other pertinent obligations, then as a consequence you may not distribute the Program at all. For example, if a patent license would not permit royalty-free redistribution of the Program by all those who receive copies directly or indirectly through you, then the only way you could satisfy both it and this License would be to refrain entirely from distribution of the Program.

If any portion of this section is held invalid or unenforceable under any particular circumstance, the balance of the section is intended to apply and the section as a whole is intended to apply in other circumstances.

It is not the purpose of this section to induce you to infringe any patents or other property right claims or to contest validity of any such claims; this section has the sole purpose of protecting the integrity of the free software distribution system, which is implemented by public license practices. Many people have made generous contributions to the wide range of software distributed through that system in reliance on consistent application of that system; it is up to the author/donor to decide if he or she is willing to distribute software through any other system and a licensee cannot impose that choice.

This section is intended to make thoroughly clear what is believed to be a consequence of the rest of this License.

8. If the distribution and/or use of the Program is restricted in certain countries either by patents or by copyrighted interfaces, the original copyright holder who places the Program under this License may add an explicit geographical distribution limitation excluding those countries, so that distribution is permitted only in or among countries not thus excluded. In such case, this License incorporates the limitation as if written in the body of this License.
9. The Free Software Foundation may publish revised and/or new versions of the General Public License from time to time. Such new versions will be similar in spirit to the present version, but may differ in detail to address new problems or concerns.

Each version is given a distinguishing version number. If the Program specifies a version number of this License which applies to it and "any later version", you have the option of following the terms and conditions either of that version or of any later version published by the Free Software Foundation. If the Program does not specify a version number of this License, you may choose any version ever published by the Free Software Foundation.

10. If you wish to incorporate parts of the Program into other free programs whose distribution conditions are different, write to the author to ask for permission. For software which is copyrighted by the Free Software Foundation, write to the Free Software Foundation; we sometimes make exceptions for this. Our decision will be guided by the two goals of preserving the free status of all derivatives of our free software and of promoting the sharing and reuse of software generally.

## NO WARRANTY

11. BECAUSE THE PROGRAM IS LICENSED FREE OF CHARGE, THERE IS NO WARRANTY FOR THE PROGRAM, TO THE EXTENT PERMITTED BY APPLICABLE LAW. EXCEPT WHEN OTHERWISE STATED IN WRITING THE COPYRIGHT HOLDERS AND/OR OTHER PARTIES PROVIDE THE PROGRAM "AS IS" WITHOUT WARRANTY OF ANY KIND, EITHER EXPRESSED OR IMPLIED, INCLUDING, BUT NOT LIMITED TO, THE IMPLIED WARRANTIES OF MERCHANTABILITY AND FITNESS FOR A PARTICULAR PURPOSE. THE ENTIRE RISK AS TO THE QUALITY AND PERFORMANCE OF THE PROGRAM IS WITH YOU. SHOULD THE PROGRAM PROVE DEFECTIVE, YOU ASSUME THE COST OF ALL NECESSARY SERVICING, REPAIR OR CORRECTION.
12. IN NO EVENT UNLESS REQUIRED BY APPLICABLE LAW OR AGREED TO IN WRITING WILL ANY COPYRIGHT HOLDER, OR ANY OTHER PARTY WHO MAY MODIFY AND/OR REDISTRIBUTE THE PROGRAM AS PERMITTED ABOVE, BE LIABLE TO YOU FOR DAMAGES, INCLUDING ANY GENERAL, SPECIAL, INCIDENTAL OR CONSEQUENTIAL DAMAGES ARISING OUT OF THE USE OR INABILITY TO USE THE PROGRAM (INCLUDING BUT NOT LIMITED TO LOSS OF DATA OR DATA BEING RENDERED INACCURATE OR LOSSES SUSTAINED BY YOU OR THIRD PARTIES OR A FAILURE OF THE PROGRAM TO OPERATE WITH ANY OTHER PROGRAMS), EVEN IF SUCH HOLDER OR OTHER PARTY HAS BEEN ADVISED OF THE POSSIBILITY OF SUCH DAMAGES.

## END OF TERMS AND CONDITIONS

### How to Apply These Terms to Your New Programs

If you develop a new program, and you want it to be of the greatest possible use to the public, the best way to achieve this is to make it free software which everyone can redistribute and change under these terms.

To do so, attach the following notices to the program. It is safest to attach them to the start of each source file to most effectively convey the exclusion of warranty; and each file should have at least the "copyright" line and a pointer to where the full notice is found.

<one line to give the program's name and a brief idea of what it does.>

Copyright (C) <year> <name of author>

This program is free software; you can redistribute it and/or modify it under the terms of the GNU General Public License as published by the Free Software Foundation; either version 2 of the License, or (at your option) any later version.

This program is distributed in the hope that it will be useful, but WITHOUT ANY WARRANTY; without even the implied warranty of MERCHANTABILITY or FITNESS FOR A PARTICULAR PURPOSE. See the GNU General Public License for more details.

You should have received a copy of the GNU General Public License along with this program; if not, write to the Free Software Foundation, Inc., 59 Temple Place, Suite 330, Boston, MA 02111-1307 USA.

Also add information on how to contact you by electronic and paper mail.

If the program is interactive, make it output a short notice like this when it starts in an interactive mode:

Gnomovision version 69, Copyright (C) year name of author Gnomovision comes with ABSOLUTELY NO WARRANTY; for details type 'show w'. This is free software, and you are welcome to redistribute it under certain conditions; type 'show c' for details.

The hypothetical commands 'show w' and 'show c' should show the appropriate parts of the General Public License. Of course, the commands you use may be called something other than 'show w' and 'show c'; they could even be mouse-clicks or menu items—whatever suits your program.

You should also get your employer (if you work as a programmer) or your school, if any, to sign a "copyright disclaimer" for the program, if necessary. Here is a sample; alter the names:

Yoyodyne, Inc., hereby disclaims all copyright interest in the program 'Gnomovision' (which makes passes at compilers) written by James Hacker.

<signature of Ty Coon>, 1 April 1989

Ty Coon, President of Vice

This General Public License does not permit incorporating your program into proprietary programs. If your program is a subroutine library, you may consider it more useful to permit linking proprietary applications with the library. If this is what you want to do, use the GNU Library General Public License instead of this License.

## GNU LESSER GENERAL PUBLIC LICENSE

### Version 2.1, February 1999

Copyright (C) 1991, 1999 Free Software Foundation, Inc.  
59 Temple Place, Suite 330, Boston, MA 02111-1307 USA

Everyone is permitted to copy and distribute verbatim copies of this license document, but changing it is not allowed.

[This is the first released version of the Lesser GPL. It also counts as the successor of the GNU Library General Public License, version 2, hence the version number 2.1.]

### Preamble

The licenses for most software are designed to take away your freedom to share and change it. By contrast, the GNU General Public Licenses are intended to guarantee your freedom to share and change free software—to make sure the software is free for all its users.

This license, the Lesser General Public License, applies to some specially designated software packages—typically libraries—of the Free Software Foundation and other authors who decide to use it. You can use it too, but we suggest you first think carefully about whether this license or the ordinary General Public License is the better strategy to use in any particular case, based on the explanations below.

When we speak of free software, we are referring to freedom of use, not price. Our General Public Licenses are designed to make sure that you have the freedom to distribute copies of free software (and charge for this service if you wish); that you receive source code or can get it if you want it; that you can change the software and use pieces of it in new free programs; and that you are informed that you can do these things.

To protect your rights, we need to make restrictions that forbid distributors to deny you these rights or to ask you to surrender these rights. These restrictions translate to certain responsibilities for you if you distribute copies of the library or if you modify it.

For example, if you distribute copies of the library, whether gratis or for a fee, you must give the recipients all the rights that we gave you. You must make sure that they, too, receive or can get the source code. If you link other code with the library, you must provide complete object files to the recipients, so that they can relink them with the library after making changes to the library and recompiling it. And you must show them these terms so they know their rights.

We protect your rights with a two-step method: (1) we copyright the library, and (2) we offer you this license, which gives you legal permission to copy, distribute and/or modify the library.

To protect each distributor, we want to make it very clear that there is no warranty for the free library. Also, if the library is modified by someone else and passed on, the recipients should know that what they have is not the original version, so that the original author's reputation will not be affected by problems that might be introduced by others.

Finally, software patents pose a constant threat to the existence of any free program. We wish to make sure that a company cannot effectively restrict the users of a free program by obtaining a restrictive license from a patent holder. Therefore, we insist that any patent license obtained for a version of the library must be consistent with the full freedom of use specified in this license.

Most GNU software, including some libraries, is covered by the ordinary GNU General Public License. This license, the GNU Lesser General Public License, applies to certain designated libraries, and is quite different from the ordinary General Public License. We use this license for certain libraries in order to permit linking those libraries into non-free programs.

When a program is linked with a library, whether statically or using a shared library, the combination of the two is legally speaking a combined work, a derivative of the original library. The ordinary General Public License therefore permits such linking only if the entire combination fits its criteria of freedom. The Lesser General Public License permits more lax criteria for linking other code with the library.

We call this license the "Lesser" General Public License because it does Less to protect the user's freedom than the ordinary General Public License. It also provides other free software developers Less of an advantage over competing non-free programs. These disadvantages are the reason we use the ordinary General Public License for many libraries.

However, the Lesser license provides advantages in certain special circumstances.

For example, on rare occasions, there may be a special need to encourage the widest possible use of a certain library, so that it becomes a de-facto standard. To achieve this, non-free programs must be allowed to use the library. A more frequent case is that a free library does the same job as widely used non-free libraries. In this case, there is little to gain by limiting the free library to free software only, so we use the Lesser General Public License.

In other cases, permission to use a particular library in non-free programs enables a greater number of people to use a large body of free software. For example, permission to use the GNU C Library in non-free programs enables many more people to use the whole GNU operating system, as well as its variant, the GNU/Linux operating system.

Although the Lesser General Public License is less protective of the users' freedom, it does ensure that the user of a program that is linked with the Library has the freedom and the wherewithal to run that program using a modified version of the Library.

The precise terms and conditions for copying, distribution and modification follow. Pay close attention to the difference between a "work based on the library" and a "work that uses the library". The former contains code derived from the library, whereas the latter must be combined with the library in order to run.

## TERMS AND CONDITIONS FOR COPYING, DISTRIBUTION AND MODIFICATION

0. This License Agreement applies to any software library or other program which contains a notice placed by the copyright holder or other authorized party saying it may be distributed under the terms of this Lesser General Public License (also called "this License"). Each licensee is addressed as "you".

A "library" means a collection of software functions and/or data prepared so as to be conveniently linked with application programs (which use some of those functions and data) to form executables.

The "Library", below, refers to any such software library or work which has been distributed under these terms. A "work based on the Library" means either the Library or any derivative work under copyright law; that is to say, a work containing the Library or a portion of it, either verbatim or with modifications and/or translated straightforwardly into another language. (Hereinafter, translation is included without limitation in the term "modification".)

"Source code" for a work means the preferred form of the work for making modifications to it. For a library, complete source code means all the source code for all modules it contains, plus any associated interface definition files, plus the scripts used to control compilation and installation of the library.

Activities other than copying, distribution and modification are not covered by this License; they are outside its scope. The act of running a program using the Library is not restricted, and output from such a program is covered only if its contents constitute a work based on the Library (independent of the use of the Library in a tool for writing it). Whether that is true depends on what the Library does and what the program that uses the Library does.

1. You may copy and distribute verbatim copies of the Library's complete source code as you receive it, in any medium, provided that you conspicuously and appropriately publish on each copy an appropriate copyright notice and disclaimer of warranty; keep intact all the notices that refer to this License and to the absence of any warranty; and distribute a copy of this License along with the Library.

You may charge a fee for the physical act of transferring a copy, and you may at your option offer warranty protection in exchange for a fee.

2. You may modify your copy or copies of the Library or any portion of it, thus forming a work based on the Library, and copy and distribute such modifications or work under the terms of Section 1 above, provided that you also meet all of these conditions:

- a) The modified work must itself be a software library.
- b) You must cause the files modified to carry prominent notices stating that you changed the files and the date of any change.
- c) You must cause the whole of the work to be licensed at no charge to all third parties under the terms of this License.
- d) If a facility in the modified Library refers to a function or a table of data to be supplied by an application program that uses the facility, other than as an argument passed when the facility is invoked, then you must make a good faith effort to ensure that, in the event an application does not supply such function or table, the facility still operates, and performs whatever part of its purpose remains meaningful.

(For example, a function in a library to compute square roots has a purpose that is entirely well-defined independent of the application. Therefore, Subsection 2d requires that any application-supplied function or table used by this function must be optional: if the application does not supply it, the square root function must still compute square roots.)

These requirements apply to the modified work as a whole. If identifiable sections of that work are not derived from the Library, and can be reasonably considered independent and separate works in themselves, then this License, and its terms, do not apply to those sections when you distribute them as separate works. But when you distribute the same sections as part of a whole which is a work based on the Library, the distribution of the whole must be on the terms of this License, whose permissions for other licensees extend to the entire whole, and thus to each and every part regardless of who wrote it.

Thus, it is not the intent of this section to claim rights or contest your rights to work

written entirely by you; rather, the intent is to exercise the right to control the distribution of derivative or collective works based on the Library.

In addition, mere aggregation of another work not based on the Library with the Library (or with a work based on the Library) on a volume of a storage or distribution medium does not bring the other work under the scope of this License.

3. You may opt to apply the terms of the ordinary GNU General Public License instead of this License to a given copy of the Library. To do this, you must alter all the notices that refer to this License, so that they refer to the ordinary GNU General Public License, version 2, instead of to this License. (If a newer version than version 2 of the ordinary GNU General Public License has appeared, then you can specify that version instead if you wish.) Do not make any other change in these notices.

Once this change is made in a given copy, it is irreversible for that copy, so the ordinary GNU General Public License applies to all subsequent copies and derivative works made from that copy.

This option is useful when you wish to copy part of the code of the Library into a program that is not a library.

4. You may copy and distribute the Library (or a portion or derivative of it, under Section 2) in object code or executable form under the terms of Sections 1 and 2 above provided that you accompany it with the complete corresponding machine-readable source code, which must be distributed under the terms of Sections 1 and 2 above on a medium customarily used for software interchange.

If distribution of object code is made by offering access to copy from a designated place, then offering equivalent access to copy the source code from the same place satisfies the requirement to distribute the source code, even though third parties are not compelled to copy the source along with the object code.

5. A program that contains no derivative of any portion of the Library, but is designed to work with the Library by being compiled or linked with it, is called a "work that uses the Library". Such a work, in isolation, is not a derivative work of the Library, and therefore falls outside the scope of this License.

However, linking a "work that uses the Library" with the Library creates an executable that is a derivative of the Library (because it contains portions of the Library), rather than a "work that uses the library". The executable is therefore covered by this License. Section 6 states terms for distribution of such executables.

When a "work that uses the Library" uses material from a header file that is part of the Library, the object code for the work may be a derivative work of the Library even though the source code is not. Whether this is true is especially significant if the work can be linked without the Library, or if the work is itself a library. The threshold for this to be true is not precisely defined by law.

If such an object file uses only numerical parameters, data structure layouts and accessors, and small macros and small inline functions (ten lines or less in length), then the use of the object file is unrestricted, regardless of whether it is legally a derivative work. (Executables containing this object code plus portions of the Library will still fall under Section 6.)

Otherwise, if the work is a derivative of the Library, you may distribute the object code for the work under the terms of Section 6. Any executables containing that work also fall under Section 6, whether or not they are linked directly with the Library itself.

6. As an exception to the Sections above, you may also combine or link a "work that uses the Library" with the Library to produce a work containing portions of the Library, and distribute that work under terms of your choice, provided that the terms permit modification of the work for the customer's own use and reverse engineering for debugging such modifications.

You must give prominent notice with each copy of the work that the Library is used in it and that the Library and its use are covered by this License. You must supply a copy of this License. If the work during execution displays copyright notices, you must include the copyright notice for the Library among them, as well as a reference directing the user to the copy of this License. Also, you must do one of these things:

- a) Accompany the work with the complete corresponding machine-readable source code for the Library including whatever changes were used in the work (which must be distributed under Sections 1 and 2 above); and, if the work is an executable linked with the Library, with the complete machine-readable "work that uses the Library", as object code and/or source code, so that the user can modify the Library and then relink to produce a modified executable containing the modified Library. (It is understood that the user who changes the contents of definitions files in the Library will not necessarily be able to recompile the application to use the modified definitions.)
- b) Use a suitable shared library mechanism for linking with the Library. A suitable mechanism is one that (1) uses at run time a copy of the library already present on the user's computer system, rather than copying library functions into the executable, and (2) will operate properly with a modified version of the library, if the user installs one, as long as the modified version is interface-compatible with the version that the work was made with.
- c) Accompany the work with a written offer, valid for at least three years, to give the same user the materials specified in Subsection 6a, above, for a charge no more than the cost of performing this distribution.

- d) If distribution of the work is made by offering access to copy from a designated place, offer equivalent access to copy the above specified materials from the same place.
- e) Verify that the user has already received a copy of these materials or that you have already sent this user a copy.

For an executable, the required form of the “work that uses the Library” must include any data and utility programs needed for reproducing the executable from it. However, as a special exception, the materials to be distributed need not include anything that is normally distributed (in either source or binary form) with the major components (compiler, kernel, and so on) of the operating system on which the executable runs, unless that component itself accompanies the executable.

It may happen that this requirement contradicts the license restrictions of other proprietary libraries that do not normally accompany the operating system. Such a contradiction means you cannot use both them and the Library together in an executable that you distribute.

- 7. You may place library facilities that are a work based on the Library side-by-side in a single library together with other library facilities not covered by this License, and distribute such a combined library, provided that the separate distribution of the work based on the Library and of the other library facilities is otherwise permitted, and provided that you do these two things:
  - a) Accompany the combined library with a copy of the same work based on the Library, uncombined with any other library facilities. This must be distributed under the terms of the Sections above.
  - b) Give prominent notice with the combined library of the fact that part of it is a work based on the Library, and explaining where to find the accompanying uncombined form of the same work.
- 8. You may not copy, modify, sublicense, link with, or distribute the Library except as expressly provided under this License. Any attempt otherwise to copy, modify, sublicense, link with, or distribute the Library is void, and will automatically terminate your rights under this License. However, parties who have received copies, or rights, from you under this License will not have their licenses terminated so long as such parties remain in full compliance.
- 9. You are not required to accept this License, since you have not signed it. However, nothing else grants you permission to modify or distribute the Library or its derivative works. These actions are prohibited by law if you do not accept this License. Therefore, by modifying or distributing the Library (or any work based on the Library), you indicate your acceptance of this License to do so, and all its terms and conditions for copying, distributing or modifying the Library or works based on it.
- 10. Each time you redistribute the Library (or any work based on the Library), the recipient automatically receives a license from the original licensor to copy, distribute, link with or modify the Library subject to these terms and conditions. You may not impose any further restrictions on the recipients’ exercise of the rights granted herein. You are not responsible for enforcing compliance by third parties with this License.
- 11. If, as a consequence of a court judgment or allegation of patent infringement or for any other reason (not limited to patent issues), conditions are imposed on you (whether by court order, agreement or otherwise) that contradict the conditions of this License, they do not excuse you from the conditions of this License. If you cannot distribute so as to satisfy simultaneously your obligations under this License and any other pertinent obligations, then as a consequence you may not distribute the Library at all. For example, if a patent license would not permit royalty-free redistribution of the Library by all those who receive copies directly or indirectly through you, then the only way you could satisfy both it and this License would be to refrain entirely from distribution of the Library.

If any portion of this section is held invalid or unenforceable under any particular circumstance, the balance of the section is intended to apply, and the section as a whole is intended to apply in other circumstances.

It is not the purpose of this section to induce you to infringe any patents or other property right claims or to contest validity of any such claims; this section has the sole purpose of protecting the integrity of the free software distribution system which is implemented by public license practices. Many people have made generous contributions to the wide range of software distributed through that system in reliance on consistent application of that system; it is up to the author/donor to decide if he or she is willing to distribute software through any other system and a licensee cannot impose that choice.

This section is intended to make thoroughly clear what is believed to be a consequence of the rest of this License.

- 12. If the distribution and/or use of the Library is restricted in certain countries either by patents or by copyrighted interfaces, the original copyright holder who places the Library under this License may add an explicit geographical distribution limitation excluding those countries, so that distribution is permitted only in or among countries not thus excluded. In such case, this License incorporates the limitation as if written in the body of this License.
- 13. The Free Software Foundation may publish revised and/or new versions of the Lesser General Public License from time to time. Such new versions will be similar in spirit to the present version, but may differ in detail to address new problems or concerns.

Each version is given a distinguishing version number. If the Library specifies a version number of this License which applies to it and “any later version”, you have the option of following the terms and conditions either of that version or of any later version published by the Free Software Foundation. If the Library does not specify a license version number, you may choose any version ever published by the Free Software Foundation.

- 14. If you wish to incorporate parts of the Library into other free programs whose distribution conditions are incompatible with these, write to the author to ask for permission. For software which is copyrighted by the Free Software Foundation, write to the Free Software Foundation; we sometimes make exceptions for this. Our decision will be guided by the two goals of preserving the free status of all derivatives of our free software and of promoting the sharing and reuse of software generally.

## NO WARRANTY

- 15. BECAUSE THE LIBRARY IS LICENSED FREE OF CHARGE, THERE IS NO WARRANTY FOR THE LIBRARY, TO THE EXTENT PERMITTED BY APPLICABLE LAW. EXCEPT WHEN OTHERWISE STATED IN WRITING THE COPYRIGHT HOLDERS AND/OR OTHER PARTIES PROVIDE THE LIBRARY “AS IS” WITHOUT WARRANTY OF ANY KIND, EITHER EXPRESSED OR IMPLIED, INCLUDING, BUT NOT LIMITED TO, THE IMPLIED WARRANTIES OF MERCHANTABILITY AND FITNESS FOR A PARTICULAR PURPOSE. THE ENTIRE RISK AS TO THE QUALITY AND PERFORMANCE OF THE LIBRARY IS WITH YOU. SHOULD THE LIBRARY PROVE DEFECTIVE, YOU ASSUME THE COST OF ALL NECESSARY SERVICING, REPAIR OR CORRECTION.
- 16. IN NO EVENT UNLESS REQUIRED BY APPLICABLE LAW OR AGREED TO IN WRITING WILL ANY COPYRIGHT HOLDER, OR ANY OTHER PARTY WHO MAY MODIFY AND/OR REDISTRIBUTE THE LIBRARY AS PERMITTED ABOVE, BE LIABLE TO YOU FOR DAMAGES, INCLUDING ANY GENERAL, SPECIAL, INCIDENTAL OR CONSEQUENTIAL DAMAGES ARISING OUT OF THE USE OR INABILITY TO USE THE LIBRARY (INCLUDING BUT NOT LIMITED TO LOSS OF DATA OR DATA BEING RENDERED INACCURATE OR LOSSES SUSTAINED BY YOU OR THIRD PARTIES OR A FAILURE OF THE LIBRARY TO OPERATE WITH ANY OTHER SOFTWARE), EVEN IF SUCH HOLDER OR OTHER PARTY HAS BEEN ADVISED OF THE POSSIBILITY OF SUCH DAMAGES.

## END OF TERMS AND CONDITIONS

### How to Apply These Terms to Your New Libraries

If you develop a new library, and you want it to be of the greatest possible use to the public, we recommend making it free software that everyone can redistribute and change. You can do so by permitting redistribution under these terms (or, alternatively, under the terms of the ordinary General Public License).

To apply these terms, attach the following notices to the library. It is safest to attach them to the start of each source file to most effectively convey the exclusion of warranty; and each file should have at least the “copyright” line and a pointer to where the full notice is found.

<one line to give the library’s name and a brief idea of what it does.>

Copyright (C) <year> <name of author>

This library is free software; you can redistribute it and/or modify it under the terms of the GNU Lesser General Public License as published by the Free Software Foundation; either version 2.1 of the License, or (at your option) any later version.

This library is distributed in the hope that it will be useful, but WITHOUT ANY WARRANTY; without even the implied warranty of MERCHANTABILITY or FITNESS FOR A PARTICULAR PURPOSE. See the GNU Lesser General Public License for more details.

You should have received a copy of the GNU Lesser General Public License along with this library; if not, write to the Free Software Foundation, Inc., 59 Temple Place, Suite 330, Boston, MA 02111-1307 USA

Also add information on how to contact you by electronic and paper mail.

You should also get your employer (if you work as a programmer) or your school, if any, to sign a “copyright disclaimer” for the library, if necessary. Here is a sample; alter the names:

Yoyodyne, Inc., hereby disclaims all copyright interest in the library ‘Frob’ (a library for tweaking knobs) written by James Random Hacker.

<signature of Ty Coon>, 1 April 1990

Ty Coon, President of Vice

That’s all there is to it!



# LIST OF REMOTE CONTROL CODES

## CABLE

ABC	0030, 0035
AMERICAST	0926
BELL SOUTH	0926
BIRMINGHAM CABLE COMMUNICATIONS	0303
BRITISH TELECOM	0030
CABLE & WIRELESS	1095
DAERYUNG	0035, 0504, 0904, 1904
DIRECTOR	0503
FILMNET	0470
GENERAL INSTRUMENT	0030, 0303, 0503, 0837,
GOLDSTAR	0171
HAMLIN	0036, 0300
JERROLD	0030, 0303, 0503, 0837
LG	0171
MNET	0470
MEMOREX	0027
MOTOROLA	0303, 0503, 0837, 1133
NLT	1095
NOOS	0844
ONO	1095
PVP STEREO VISUAL MATRIX	0030
PACE	0264, 1087, 1095
PANASONIC	0027, 0035, 0134
PARAGON	0027
PHILIPS	0332, 0344
PIONEER	0171, 0560, 0904, 1904
PULSAR	0027
QUASAR	0027
REGAL	0300, 0306
RUNCO	0027
SAGEM	0844
SAMSUNG	0027, 0171
SCIENTIFIC ATLANTA	0035, 0504, 0904, 1904
SONY	1033
STARCOM	0030
SUPERCABLE	0303
TS	0030
TELE+1	0470
TELEWEST	1095
TORX	0030
TOSHIBA	0027
TRANS PX	0303
UNITED CABLE	0030
ZENITH	0027, 0552, 0926

## CD PLAYER

AIWA	0184
ARCAM	0184
AUDIO RESEARCH	0184
AUDIO TON	0184
AUDIOLAB	0184
AUDIOMECA	0184
CAIRN	0184

## CALIFORNIA AUDIO LABS

	0056
CARVER	0184, 0206
CYRUS	0184
DKK	0027
DMX ELECTRONICS	0184
DENON	0900
DYNAMIC BASS	0206
EMERSON	0332
FISHER	0206
GENEXXA	0059, 0332
GOODMANS	0332
GRUNDIG	0184
HARMAN/KARDON	0184, 0200
HITACHI	0059
JVC	0099
KENWOOD	0055, 0064
KRELL	0184
LXI	0332
LINN	0184
MCS	0056
MAGNAVOX	0184, 0332
MARANTZ	0056, 0184
MATSUI	0184
MEMOREX	0332
MERIDIAN	0184
MICROMEGA	0184
MIRO	0027
MISSION	0184
MYRYAD	0184
NAD	0027
NSM	0184
NAIM	0184
OPTIMUS	0027, 0059, 0064, 0206, 0332
PANASONIC	0056
PHILIPS	0184
PIONEER	0059, 0332
POLK AUDIO	0184
PROTON	0184
QED	0184
QUAD	0184
QUASAR	0056
RCA	0059, 0206, 0332
REALISTIC	0206
REVOX	0184
ROTEL	0184
SAE	0184
SANSUI	0184, 0332
SANYO	0206
SCOTT	0332
SEARS	0332
SHARP	0064
SIMAUDIO	0184
SONIC FRONTIERS	0184
SONY	0027
SYMPHONIC	0332
TAG MCLAREN	0184
TANDY	0059
TECHNICS	0056
THORENS	0184
THULE	0184
UNIVERSUM	0184
VICTOR	0099
WARDS	0184
YAMAHA	2300, 2301

## CD RECORDER

KENWOOD	0653
MARANTZ	0653
PHILIPS	0653
YAMAHA	2400

## DVD PLAYER

### ACOUSTIC SOLUTIONS

	0757
ALBA	0744
AMSTRAD	0740
APEX DIGITAL	0699, 0744, 0782, 0821, 0823, 0857, 1127

BLAUPINKT	0744
BLUE PARADE	0598

BUSH	0740
CENTREX	0699
CLATRONIC	0815
CYBERHOME	0741
DVD2000	0548

DAEWOO	0811, 0797
DANSAI	0797

DECCA	0797
DENON	0517

DIAMOND	0795
DIGITREX	0699

EMERSON	0618
ENTERPRISE	0618

FISHER	0697
GE	0549, 0744

GO VIDEO	0742
GOLDSTAR	0768

GRADIENTE	0678
GREENHILL	0744

GRUNDIG	0566
HITACHI	0600, 0691

HITEKER	0699
JVC	0585, 0650

KLH	0744
KENWOOD	0517, 0561

KOSS	0678
LG	0768

LIMIT	0795
MAGNAVOX	0530, 0702

MARANTZ	0566
MEMOREX	0858

MICO	0750
MICROSOFT	0549

MINTEK	0744
MITSUBISHI	0548

MUSTEK	0757
NESA	0744

ONKYO	0530
ORITRON	0678

PALSONIC	0699
PANASONIC	0517, 0659, 1389

PHILIPS	0530, 0566, 0673, 0881
---------	------------------------

PIONEER	0552, 0598, 0658, 0659
---------	------------------------

POLK AUDIO	0566
PROSCAN	0549

QWESTAR	0678
RCA	0549, 0598, 0744

ROTEL	0650
-------	------

## SM ELECTRONIC 0757

SAMSUNG	0600
SANYO	0697
SHARP	0657
SHERWOOD	0797
SHINSONIC	0560
SLIM ART	0811
SONY	0560, 0891
SYLVANIA	0702
TATUNG	0797
TEAC	0598, 0744
TECHNICS	0517
THETA DIGITAL	0598
THOMSON	0549
TOSHIBA	0530
URBAN CONCEPTS	0530
XBOX	0549
YAMAHA	0517, 0566, 0572, 2100
ZENITH	0530, 0618, 0768
ZEUS	0811

## DVD RECORDER

HITACHI	2815
PANASONIC	2800, 2801, 2802
PHILIPS	2808
PIONEER	2804, 2805, 2806
SHARP	2812, 2813
SONY	2809, 2810, 2811
TOSHIBA	2803
VICTOR	2814
YAMAHA	2807

## LD PLAYER

CARVER	0091
DENON	0086
MARANTZ	0091
MITSUBISHI	0086
NAD	0086
NAGSMI	0086
OPTIMUS	0086
PHILIPS	0091
PIONEER	0086
SALORA	0091
SONY	0228
TELEFUNKEN	0086
YAMAHA	2200

## MD RECORDER

KENWOOD	0708
ONKYO	0895
SHARP	0888
SONY	0517
YAMAHA	2500, 2501, 2502

## RECEIVER (TUNER)

ADC	0558
AIWA	0185, 1116, 1415, 1432, 1668
ALCO	1417
ANAM	1636
APEX DIGITAL	1284
AUDIOLAB	1216
AUDIOTRONIC	1216
AUDIOVOX	1417
BOSE	1256

**CAMBRIDGE SOUNDWORKS**

1397  
 CAPETRONIC 0558  
 CARVER 1116, 1216  
 CENTREX 1284  
 DENON 1387  
 FERGUSON 0558  
 FINE ARTS 1216  
 GRUNDIG 1216  
 HARMAN/KARDON  
 0137, 1331  
 INTEGRA 0162, 1325  
 JBL 0137, 1333  
 JVC 0101, 0558, 1401,  
 1522  
 KLH 1417, 1439  
 KENWOOD 1054, 1340  
 MCS 0066  
 MAGNAVOX 0558, 1116, 1216,  
 1296,  
 MARANTZ 0066, 1116, 1216,  
 1316  
 MICROMEGA 1216  
 MUSICMAGIC 1116  
 MYRYAD 1216  
 NAD 0347  
 NORCENT 1416  
 ONKYO 0162, 0869, 1325  
 OPTIMUS 0558, 1050  
 PANASONIC 0066, 1315, 1545,  
 1790  
 PHILIPS 1116, 1216, 1293,  
 1295, 1296, 1310,  
 1316  
 PIONEER 0041, 0558, 1050,  
 1411  
 POLK AUDIO 1316  
 PROSCAN 1281  
 QUASAR 0066  
 RCA 0558, 1050, 1281,  
 1417, 1636,  
 SABA 0558  
 SANSUI 1116  
 SCHNEIDER 0558  
 SONY 0185, 1085, 1185,  
 1685, 1785  
 STEREOPHONICS 1050  
 SUNFIRE 1340  
 TEAC 1417  
 TECHNICS 0066, 1335, 1336,  
 1545  
 TELEFUNKEN 0558  
 THOMSON 1281  
 THORENS 1216  
 UHER 0558  
 VENTURER 1417  
 VICTOR 0101  
 WARDS 0041, 0185  
 YAMAHA 0203, 1203, 1358,  
 2601  
 (TUNER ID1) 2602  
 (TUNER ID2) 2603  
 (XM ID1) 2604  
 (XM ID2) 2605  
 (iPod) 2606  
 (NET) 2607

**SATELLITE TUNER**

@SAT 1327  
 ABSAT 0150  
 ALBA 0482  
 ALPHASTAR 0799  
 AMSTRAD 0874  
 ASTON 0169, 1156

ASTRO 0200  
 ATSAT 1327  
 AVALON 0423  
 BLAUPUNKT 0200  
 BRITISH SKY BROADCASTING  
 0874, 1202  
 CANAL DIGITAL 0880  
 CANAL SATELLITE 0880  
 CANAL+ 0880  
 CHAPARRAL 0243  
 CITYCOM 1203  
 CONNEXIONS 0423  
 CROSSDIGITAL 1136  
 CYRUS 0227  
 D-BOX 0750, 1154  
 DMT 1102  
 DNT 0227, 0423  
 DAERYUNG 0423  
 DAEWOO 1323  
 DIGENIUS 0326  
 DIRECTV 0274, 0419, 0593,  
 0666, 0751, 0776,  
 0846, 1103, 1136,  
 1169, 1776, 1883  
 DISH NETWORK SYSTEM  
 0802, 1032  
 DISHPRO 0802, 1032  
 DISTRATEL 0111  
 DREAM MULTIMEDIA  
 1264  
 ECHOSTAR 0194, 0423, 0637,  
 0802, 0880, 0898,  
 1032, 1113  
 ENGEL 1044  
 EXPRESSVU 0802  
 FTE 0890  
 FINLUX 0482  
 FRACARRO 0898  
 FUBA 0423  
 GE 0593  
 GOI 0802  
 GALAXIS 0890, 1138  
 GENERAL INSTRUMENT  
 0896  
 GOLD BOX 0880  
 GRUNDIG 0200, 0874  
 HTS 0802  
 HIRSCHMANN 0200, 0423  
 HITACHI 0482, 0846  
 HUGHES NETWORK SYSTEM  
 0776, 1169, 1776  
 HUMAX 0890, 1203  
 INVIDEO 0898  
 JVC 0802  
 KATHREIN 0150, 0200, 0227,  
 0276, 0685, 1248  
 KREISELMEYER 0200  
 LABGEAR 1323  
 LOGIX 1044  
 LORENZEN 0326  
 MAGNAVOX 0749, 0751  
 MANHATTAN 0482, 1044,  
 1110  
 MARANTZ 0227  
 MEDIASAT 0880  
 MEMOREX 0751  
 METRONIC 0111  
 MITSUBISHI 0776  
 MOTOROLA 0896  
 MYRYAD 0227  
 NEXT LEVEL 0896  
 NOKIA 0482, 0750, 0778,  
 1154, 1250, 1750  
 OCTALTV 1032

ORBITECH 1127  
 PACE 0482, 0874, 1202,  
 1350  
 PANASONIC 0274, 0728, 0874,  
 1347  
 PANDA 0482  
 PAYSAT 0751  
 PHILIPS 0160, 0227, 0482,  
 0749, 0751, 0776,  
 0880, 1103, 1169,  
 1776  
 PIONEER 0880  
 PROMAX 0482  
 PROSCAN 0419, 0593  
 RCA 0170, 0419, 0593,  
 0882  
 RFT 0227  
 RADIOSHACK 0896  
 RADIOLA 0227  
 RADIX 0423  
 SKY 0874, 0883, 1202  
 SM ELECTRONIC 1227  
 SABRE 0482  
 SAGEM 0847, 1141, 1280  
 SAMSUNG 1044, 1136, 1303,  
 1319  
 SAT CONTROL 1327  
 SATSTATION 1110  
 SCHWAIGER 1138  
 SEEMANN 0423  
 SIEMENS 0200  
 SONY 0666, 0874, 1666  
 STAR CHOICE 0896  
 STRONG 1327  
 TPS 0847, 1280  
 TANTEC 0482  
 TECHNISAT 1126, 1127  
 TELESTAR 1127  
 THOMSON 0482, 0880, 1073,  
 1318  
 TOPFIELD 1233  
 TOSHIBA 0776, 0817, 1776  
 ULTIMATETV 0419, 0666  
 UNIDEN 0749, 0751  
 UNIVERSUM 0200  
 VENTANA 0227  
 WISI 0200, 0423, 0482  
 XSAT 0150  
 ZEHNDR 1102  
 ZENITH 0883, 1883

**TAPE DECK**

AIWA 0056  
 CARVER 0056  
 GRUNDIG 0056  
 HARMAN/KARDON  
 0056  
 MAGNAVOX 0056  
 MARANTZ 0056  
 MYRYAD 0056  
 OPTIMUS 0054  
 PHILIPS 0056  
 PIONEER 0054  
 POLK AUDIO 0056  
 RCA 0054  
 REVOX 0056  
 SANSUI 0056  
 SONY 0270  
 THORENS 0056  
 WARDS 0054  
 YAMAHA 2700, 2701

**TV**

AGB 0543  
 AOC 0036, 0057, 0087,  
 0119, 0120, 0135,  
 0205, 0207, 0478  
 0131  
 ASA 0131  
 AWA 0036  
 ACURA 0036  
 ADDISON 0119, 0135, 0680  
 ADMIRAL 0120, 0190, 0490  
 ADVENT 0788  
 AIKO 0119  
 AKAI 0036, 0057, 0235,  
 0388, 0543, 0729,  
 0839  
 AKURA 0291  
 ALBA 0036, 0064, 0398,  
 0695  
 AMERICA ACTION 0207  
 AMPRO 0778  
 AMSTRAD 0036, 0064, 0198,  
 0398, 0439, 0460,  
 0543  
 ANAM 0036, 0207, 0277  
 ANAM NATIONAL 0277, 0677  
 ANITECH 0036  
 APEX DIGITAL 0775, 0792,  
 0794  
 AUDIOSONIC 0064, 0136  
 BANG & OLUFSEN 0592  
 BASIC 0036  
 BAUR 0064, 0388, 0539  
 BAYSONIC 0207  
 BEAUMARK 0205  
 BEKO 0397, 0513, 0741,  
 0742  
 BELL & HOWELL 0181  
 BEON 0064  
 BLAUPUNKT 0222  
 BLUE SKY 0695, 1064  
 BONDSTEC 0274  
 BRADFORD 0207  
 BRANDT 0136, 0362  
 BROKSONIC 0263, 0490  
 BUSH 0036, 0064, 0398,  
 0401, 0695, 1064  
 CCE 0064  
 CGE 0274  
 CTC 0274  
 CXC 0207  
 CANDLE 0057  
 CARNIVALE 0057  
 CARVER 0081, 0197  
 CASCADE 0036  
 CATHAY 0064  
 CELEBRITY 0027  
 CELERA 0792  
 CENTURION 0064  
 CHANGHONG 0792  
 CHING TAI 0036, 0119  
 CHUN YUN 0027, 0036, 0119,  
 0207  
 CHUNG HSIN 0080, 0135, 0207  
 CIMLINE 0036  
 CINERAL 0119, 0478  
 CITIZEN 0057, 0087, 0119  
 CLARION 0207  
 CLARIVOX 0064  
 CLATRONIC 0274, 0397  
 CONDOR 0347, 0397  
 CONRAC 0835

CONTEC	0036, 0207	GRANADA	0064, 0235, 0366, 0543	MAGNADYNE	0274, 0543	PHILIPS	0027, 0057, 0064, 0078, 0081, 0119, 0135, 0205, 0401, 0583, 0717, 1481
CRAIG	0207	GRANDIN	0637	MAGNAFON	0543	PHONOLA	0064
CROSLEY	0081	GRUNDIG	0064, 0222, 0514, 0583, 0614	MAGNAVOX	0057, 0081, 1281, 1481	PILOT	0057
CROWN	0036, 0064, 0207, 0397, 0445	GRUNPY	0207	MANESTH	0291, 0347	PIONEER	0136, 0190, 0193, 0314, 0706, 0787, 0893
CURTIS MATHES	0057, 0074, 0081, 0087, 0120, 0172, 0181, 0193, 0478, 0729, 1174, 1374	HCM	0036, 0439	MARANTZ	0057, 0064, 0081, 0583	PORTLAND	0119
DAEWOO	0036, 0057, 0064, 0119, 0135, 0181, 0197, 0205, 0207, 0401, 0478, 0650, 0661, 1688	HALLMARK	0205	MARK	0064	PRANDONI-PRINCE	0543
DANSAI	0064	HANKOOK	0057, 0205, 0207	MATSUI	0036, 0064, 0235, 0398, 0514, 0543	PRIMA	0788
DAYTON	0036	HANSEATIC	0064, 0347, 0388, 0455, 0583	MATSUSHITA	0277, 0677	PRISM	0078
DE GRAAF	0235, 0575	HANTAREX	0543	MEDIATOR	0064	PROFEX	0036, 0388
DECCA	0064, 0543	HARMAN/KARDON	0081	MEDION	0695, 0835, 1064	PROSCAN	0074
DENON	0172	HARVARD	0207	MEGATRON	0172, 0205	PROTECH	0036, 0064, 0274, 0291, 0445, 0695
DIGATRON	0064	HAVERMY	0120	MEMOREX	0036, 0177, 0181, 0205, 0277, 0490, 1064	PROTON	0036, 0057, 0205
DIXI	0036, 0064	HELLO KITTY	0478	METZ	0474	PULSAR	0044
DUMONT	0044	HINARI	0036, 0064	MICROMAXX	0835	QUASAR	0078, 0277, 0677
DWIN	0747, 0801	HISAWA	0482	MIDLAND	0044, 0074, 0078	QUELLE	0064, 0131, 0388, 0539
ECE	0064	HITACHI	0036, 0057, 0119, 0132, 0136, 0172, 0190, 0205, 0252, 0383, 0508, 0575, 0605, 1172, 1283	MINERVA	0514	R-LINE	0064
ELBE	0286	HUA TUN	0036	MINOKA	0439	RCA	0027, 0057, 0074, 0117, 0119, 0205, 0706, 1074, 1174, 1274, 1374, 1474, 1481, 1574
ELECTROBAND	0027	HUANYU	0401	MITSUBISHI	0057, 0120, 0135, 0177, 0181, 0205, 0207, 0263, 0277, 0539, 0863, 1277	RFT	0455
ELIN	0064, 0575	HYPSON	0064, 0291	MIVAR	0318, 0319, 0543, 0636	RADIOSHACK	0057, 0074, 0181, 0205, 0207
ELITE	0347	ICE	0291, 0398	MOTOROLA	0120	RADIOLA	0064
ELTA	0036	ITS	0398	MULTITECH	0036, 0207	RADIOMARELLI	0543
EMERSON	0181, 0205, 0207, 0263, 0388, 0490, 0650	ITT	0190, 0388, 0575	MYRYAD	0583	REALISTIC	0057, 0181, 0205, 0207
ENVISION	0057, 0840	IMPERIAL	0274, 0397, 0445	NAD	0183, 0205, 0388, 0893	REDIFFUSION	0388
EPSON	0860	INDIANA	0064	NEC	0036, 0057, 0078, 0181, 0183, 0197, 0205, 0482, 0524, 1731	REOC	0741
ERRES	0064	INFINITY	0081	NEI	0064	REVOX	0064
ETHER	0036, 0057	INGELEN	0190	NETC	0119	REX	0190, 0286, 0291
ETRON	0036	INNO HIT	0543	NECKERMANN	0064, 0583	ROADSTAR	0036, 0291, 0445
EUROPHON	0543	INNOVA	0064	NETSAT	0064	RUNCO	0044, 0057, 0524, 0630
FERGUSON	0064, 0100, 0136, 0265, 0314, 0362, 0587	INTEQ	0044	NEWAVE	0036, 0119, 0120, 0205	SBR	0064
FIDELITY	0388	INTERFUNK	0064, 0190, 0274, 0388, 0539	NIKKAI	0064, 0291	SEG	0291, 0695
FINLANDIA	0235, 0373	INTERVISION	0064, 0291, 0404	NIKKO	0057, 0119, 0205	SEI	0543
FINLUX	0064, 0131, 0132, 0373, 0543	JBL	0081	NOKIA	0388, 0500, 0507, 0575, 0658	SKY	0064
FIRSTAR	0036, 0263	JCB	0027	NORCENT	0775, 0851	SSS	0207
FIRSTLINE	0036, 0274, 0695	JVC	0080, 0398, 0490, 0680, 0710	NORDMENDE	0136, 0314, 0587	SABA	0136, 0190, 0314, 0362
FISHER	0131, 0181, 0235, 0397	JEAN	0036, 0078, 0119, 0183, 0263	OCEANIC	0190, 0388	SACCS	0265
FLINT	0482	JENSEN	0788	ONWA	0207, 0460	SAGEM	0637
FORMENTI	0064, 0347	KEC	0207	OPTRIMUS	0181, 0193, 0277, 0677	SAISHO	0036, 0291, 0543
FORTESS	0120	KTV	0057, 0207	OPTONICA	0120	SALORA	0190, 0380, 0388, 0575
FRONTECH	0190, 0274, 0291	KAISUI	0036	ORION	0064, 0263, 0347, 0490, 0543	SAMBERS	0543
FUJITSU	0710, 0836	KAPSCH	0190	OSAKI	0291, 0439	SAMPO	0036, 0057, 0119, 0120, 0181, 0198, 0205, 0677, 1782
FUNAI	0207, 0198, 0291	KARCHER	0637	OTTO VERSAND	0064, 0347, 0539, 0583	SAMSUNG	0036, 0057, 0064, 0087, 0117, 0119, 0181, 0205, 0291, 0397, 0583, 0614, 0645, 0729, 0793, 0839, 0841
FUTURETECH	0207	KATHREIN	0583	PALLADIUM	0397, 0445	SANSEI	0478
GE	0057, 0074, 0078, 0119, 0205, 0207, 0478, 0587, 1174, 1374, 1481	KENDO	0064	PANAMA	0291	SANSUI	0490
GEC	0064, 0543	KENWOOD	0057	PANASONIC	0064, 0078, 0081, 0190, 0277, 0677, 1437	SANYO	0131, 0181, 0207, 0235, 0366, 0826
GATEWAY	1782, 1783	KNEISSEL	0286, 0462	OSAKI	0291, 0439	SCHAUB LORENZ	0388
GELOSO	0036	KOLIN	0080, 0135, 0207	OTTO VERSAND	0064, 0347, 0539, 0583	SCHNEIDER	0064, 0274, 0398, 0695
GENEXXA	0190	KORPEL	0064	PANADIUM	0397, 0445	SCOTCH	0205
GIBRALTER	0044, 0057	KOYODA	0036	PANAMA	0291	SCOTT	0205, 0207, 0263
GOLDSTAR	0057, 0064, 0136, 0181, 0205, 0404	L&S ELECTRONIC	0835	PANASONIC	0064, 0078, 0081, 0190, 0277, 0677, 1437		
GOODMANS	0064, 0398, 0401, 0661	LG	0057, 0064, 0087, 0135, 0205, 0741	PATHE CINEMA	0265, 0347		
GOREMJE	0397	LXI	0074, 0081, 0181, 0183, 0205	PAUSA	0036		
GRADIENTE	0080, 0197	LEYCO	0064, 0291	PENNEY	0057, 0074, 0078, 0087, 0183, 0205, 1374		
GRAETZ	0190, 0388	LIESENK & TTER	0064	PERDIO	0347		
		LOEWE	0539	PHILCO	0057, 0064, 0081, 0172, 0205, 0207, 0274, 0490, 1688		
		LUXOR	0383, 0388				
		M ELECTRONIC	0036, 0064, 0131, 0132, 0136, 0190, 0314, 0373, 0401, 0507				
		MGA	0057, 0177, 0205				
		MTC	0057, 0087, 0539				

SEARS	0074, 0081, 0181, 0183, 0198, 0205	UHER	0347	COMBITECH	0379	KAISUI	0099
SELECO	0190, 0286	UNIVERSUM	0064, 0131, 0132, 0291, 0373, 0397, 0519	CRAIG	0064, 0074, 0099, 0267	KENWOOD	0068, 0094
SEMIVOX	0207			CROWN	0099, 0305	KODAK	0062, 0064
SEMP	0183	VECTOR RESEARCH	0057	CURTIS MATHES	0062, 0068, 0087, 1062	KOLIN	0068, 0070
SHARP	0057, 0120, 0677			CYBERNEX	0267	KORPEL	0099
SHEN YING	0036, 0119	VESTEL	0064	CYRUS	0108	LG	0064, 0069, 0072, 0507
SHENG CHIA	0036, 0120, 0263	VICTOR	0080, 0277, 0677, 0680	DAEWOO	0072, 0131, 0305, 0669, 1305	LXI	0064
SIAREM	0543	VIDEOSAT	0274	DANSAI	0099	LENCO	0305
SIEMENS	0064, 0222	VIDIKRON	0081	DE GRAAF	0069	LEYCO	0099
SINUDYNE	0543	VIDTECH	0205	DENON	0069	LLOYD'S	0027
SKANTIC	0383	VIEWSONIC	1782	DUAL	0068	LOEWE	0064, 0108, 1589
SKYGIANT	0207	VISION	0347	DUMONT	0027, 0108, 0131	LOGIK	0099, 0267
SKYWORTH	0064	VOXSON	0190	DYNATECH	0027	LUXOR	0070, 0075, 0131
SOLAVOX	0190	WALTHAM	0383	ESC	0267, 0305	M ELECTRONIC	0027
SONITRON	0235	WARDS	0057, 0081, 0205, 0893	ELCATECH	0099	MEI	0062
SONOKO	0036, 0064	WATSON	0064, 0347	ELECTROHOME	0064	MGA	0070, 0267
SONOLOR	0190, 0235	WAYCON	0183	ELECTROPHONIC	0064	MGN TECHNOLOGY	0267
SONTEC	0064	WHITE WESTINGHOUSE	0064, 0347, 0490, 0650	EMEREX	0059	MTC	0027, 0267
SONY	0027, 0677, 0861, 1127, 1532, 1678	YAMAHA	0057, 0172, 0677, 0796, 0860, 2900 (projector), 2901 (projector), 2903, 2904 (projector)	EMERSON	0027, 0062, 0064, 0070, 0072, 0211, 0267, 0305, 1305, 1506	MAGNASONIC	1305
SOUNDESIGN	0205, 0207			FERGUSON	0068, 0347	MAGNAVOX	0027, 0062, 0066, 0108, 1808
SOUNDWAVE	0064, 0445			FIDELITY	0027	MAGNIN	0267
SOWA	0078, 0087, 0119, 0183, 0205	YAPSHE	0277	FINLANDIA	0108, 0131	MANESTH	0072, 0099
SQUAREVIEW	0198	YOKO	0064, 0291	FINLUX	0027, 0069, 0108, 0131	MARANTZ	0062, 0108
STANDARD	0036	ZENITH	0044, 0119, 0205, 0490	FIRSTLINE	0064, 0070, 0072, 0099	MARTA	0064
STARLITE	0207			FISHER	0074, 0131	MATSUI	0375, 0379
STERN	0190, 0286			FUJI	0060, 0062	MATSUSHITA	0062
SUPREME	0027			FUJITSU	0027, 0072	MEDION	0375
SYLVANIA	0057, 0081, 0198			FUNAI	0027	MEMOREX	0027, 0062, 0064, 0066, 0074, 0075, 0131, 0267, 0334, 0375, 1264
SYMPHONIC	0198, 0207			GE	0062, 0087, 0267, 0834, 1062, 1087	MEMPHIS	0099
SYNCO	0027, 0087, 0119, 0120, 0205, 0478			GEC	0108	METZ	0064, 0374, 1589
SYSLINE	0064			GARRARD	0027	MINOLTA	0069
T + A	0474			GENERAL	0072	MITSUBISHI	0068, 0070, 0094, 0108, 0834
TCM	0835			GO VIDEO	0459	MOTOROLA	0062, 0075
TMK	0205			GOLDHAND	0099	MULTITECH	0027, 0099
TNCI	0044			GOLDSTAR	0064, 0252, 0507, 1264	MURPHY	0027
TVS	0490			GOODMANS	0027, 0064, 0099, 0305	MYRYAD	0108
TACICO	0036, 0119, 0205			GRADIENTE	0027	NAD	0131
TAI YI	0036			GRAETZ	0068, 0131, 0267	NEC	0062, 0064, 0068, 0075, 0094, 0131
TANDY	0120, 0190			GRANADA	0108, 0131	NATIONAL	0253
TASHIKO	0119, 0677			GRANDIN	0027, 0064, 0099	NECKERMANN	0108
TATUNG	0036, 0064, 0078, 0081, 0087, 0181, 0183, 0543			GRUNDIG	0099, 0108, 0253, 0374	NESCO	0099
TEAC	0036, 0064, 0291, 0439, 0445, 0482, 0695, 1064			HCM	0099	NEWAVE	0064
TEC	0274			HI-Q	0074	NIKKO	0064
TECHNEMA	0347			HARLEY DAVIDSON	0027	NOBLEX	0267
TECHNICS	0078, 0277, 0677			HARMAN/KARDON	0108	NOKIA	0068, 0131, 0267
TECHWOOD	0078			HARWOOD	0099	NORDMENDE	0068, 0347
TECO	0036, 0078, 0119, 0120, 0205, 0291, 0680			HINARI	0099, 0267, 0379	OCEANIC	0027, 0068
TEKNIKA	0081, 0087, 0119, 0177, 0207			HITACHI	0027, 0064, 0068, 0069, 0267	OKANO	0342, 0375
TELEFUNKEN	0136, 0289, 0362, 0652, 0729			HUGHES NETWORK SYSTEMS	0069	OLYMPUS	0062, 0253
TELEMEISTER	0347			HYPSON	0099	OPTIMUS	0064, 0075, 0131, 0459
TELETECH	0036			ITT	0068, 0131, 0267	ORION	0211, 0375, 0379, 1506
TENSAI	0347			ITV	0064, 0305	OSAKI	0027, 0064, 0099
TERA	0057			IMPERIAL	0027	OTTO VERSAND	0108
THOMSON	0136, 0314, 0587, 0652, 1474			INTERFUNK	0108	PALLADIUM	0064, 0068, 0099
THORN	0064, 0131, 0388, 0539			JVC	0068, 0072, 0094	PANASONIC	0062, 0252, 0253, 0643, 1062, 1589
TOSHIBA	0087, 0181, 0183, 0535, 0645, 0677, 0859, 1283, 1383, 1683, 1731			JENSEN	0068	PATHE MARCONI	0068
TRIUMPH	0543			KEC	0064, 0305	PENNEY	0062, 0064, 0069, 0267, 1062, 1264
TUNTEX	0036, 0057, 0119			KLH	0099	PENTAX	0069
						PERDIO	0027
						PHILCO	0062
						PHILIPS	0062, 0108, 0645, 1108, 1208
						PHONOLA	0108

### VCR

ASA	0064, 0108
ADMIRAL	0075
ADVENTURA	0027
AIKO	0305
AIWA	0027, 0064, 0334, 0375, 0379
AKAI	0068, 0342
AKIBA	0099
ALBA	0099, 0305, 0342, 0379
AMERICA ACTION	0305
AMERICAN HIGH	0062
AMSTRAD	0027
ANAM	0064, 0253, 0267, 0305, 0507
ANAM NATIONAL	0253, 1589
ANITECH	0099
ASHA	0267
ASUKA	0064
AUDIOVOX	0064, 0305
BAIRD	0027, 0068, 0131
BASIC LINE	0099, 0305
BEAUMARK	0267
BELL & HOWELL	0131
BLAUPUNKT	0253
BRANDT	0347
BRANDT ELECTRONIC	0068
BROKSONIC	0211, 0375, 1506
BUSH	0099, 0305, 0379
CCE	0099, 0305
CGE	0027
CALIX	0064
CANON	0062
CARVER	0108
CIMLINE	0099
CINERAL	0305
CITIZEN	0064, 0305, 1305
COLT	0099

PILOT	0064	TELEAVIA	0068
PIONEER	0069, 0094, 0108	TELEFUNKEN	0068, 0347
POLK AUDIO	0108	TENOSAL	0099
PROFITRONIC	0267	TENSAI	0027
PROLINE	0027	THOMAS	0027
PROSCAN	0087, 1087	THOMSON	0068, 0087, 0094,
PROTEC	0099		0347
PULSAR	0066	THORN	0068, 0131
PYE	0108	TIVO	0645, 0663
QUASAR	0062, 1062	TOSHIBA	0068, 0070, 0072,
QUELLE	0108		0094, 0108, 0872
RCA	0062, 0069, 0087,	TOTEVISION	0064, 0267
	0267, 0834, 1062,	UHER	0267
	1087	UNITECH	0267
RADIOSHACK	0027	UNIVERSUM	0027, 0064, 0108,
RADIOLA	0108		0267
RADIX	0064	VECTOR	0072
RANDEX	0064	VICTOR	0068, 0094
REALISTIC	0027, 0062, 0064,	VIDEO CONCEPTS	0072
	0074, 0075, 0131	VIDEOMAGIC	0064
REOC	0375	VIDEOSONIC	0267
REPLAYTV	0641, 0643	VILLAIN	0027
REX	0068	WARDS	0027, 0062, 0069,
ROADSTAR	0064, 0099, 0267,		0074, 0075, 0087,
	0305		0099, 0108, 0267
RUNCO	0066	WHITE WESTINGHOUSE	
SBR	0108		0099
SEG	0267	XR-1000	0027, 0062, 0099
SEI	0108	YAMAHA	0068
STS	0069	YAMISHI	0099
SABA	0068, 0347	YOKAN	0099
SALORA	0070	YOKO	0267
SAMPO	0064, 0075	ZENITH	0027, 0060, 0066,
SAMSUNG	0072, 0267, 0459		1506
SANKY	0066, 0075		
SANSUI	0027, 0068, 0094,		
	1506		
SANYO	0074, 0131, 0267		
SAVILLE	0379		
SCHAUB LORENZ	0027, 0068,		
	0131		
SCHNEIDER	0027, 0099, 0108		
SCOTT	0070, 0072, 0211		
SEARS	0027, 0062, 0064,		
	0069, 0074, 0131,		
	1264		
SELECO	0068		
SEMP	0072		
SHARP	0075, 0834		
SHINTOM	0099, 0131		
SIEMENS	0064, 0108, 0131		
SILVA	0064		
SINGER	0072, 0099		
SINUDYNE	0108		
SONIC BLUE	0641, 0643		
SONTEC	0064		
SONY	0027, 0059, 0060,		
	0062, 0663, 1259		
SUNKAI	0375		
SUNSTAR	0027		
SUNTRONIC	0027		
SYLVANIA	0027, 0062, 0108,		
	0070, 1808		
SYMPHONIC	0027		
TMK	0267		
TANDY	0027, 0131		
TASHIKO	0027, 0064		
TATUNG	0027, 0068, 0072,		
	0094, 0108		
TEAC	0027, 0068, 0305,		
	0334, 0669		
TECHNICS	0062, 0253		
TECO	0062, 0064, 0068,		
	0075		
TEKNIKA	0027, 0062, 0064		



© 2006 YAMAHA CORPORATION All rights reserved.

**YAMAHA ELECTRONICS CORPORATION, USA** 6660 ORANGETHORPE AVE., BUENA PARK, CALIF. 90620, U.S.A.  
**YAMAHA CANADA MUSIC LTD.** 135 MILNER AVE., SCARBOROUGH, ONTARIO M1S 3R1, CANADA  
**YAMAHA ELECTRONIK EUROPA G.m.b.H.** SIEMENSSTR. 22-34, 25462 RELLINGEN BEI HAMBURG, GERMANY  
**YAMAHA ELECTRONIQUE FRANCE S.A.** RUE AMBROISE CROIZAT BP70 CROISSY-BEAUBOURG 77312 MARNE-LA-VALLEE CEDEX02, FRANCE  
**YAMAHA ELECTRONICS (UK) LTD.** YAMAHA HOUSE, 200 RICKMANSWORTH ROAD WATFORD, HERTS WD18 7GQ, ENGLAND  
**YAMAHA SCANDINAVIA A.B.** J A WETTERGRENS GATA 1, BOX 30053, 400 43 VÄSTRA FRÖLUNDA, SWEDEN  
**YAMAHA MUSIC AUSTRALIA PTY, LTD.** 17-33 MARKET ST., SOUTH MELBOURNE, 3205 VIC., AUSTRALIA

**YAMAHA CORPORATION**  
Printed in Malaysia ◀ WJ55210